

ETSI TS 129 213 V8.13.0 (2012-01)



Technical Specification

**Digital cellular telecommunications system (Phase 2+);
Universal Mobile Telecommunications System (UMTS);
LTE;
Policy and charging control signalling flows
and Quality of Service (QoS) parameter mapping
(3GPP TS 29.213 version 8.13.0 Release 8)**



ReferenceRTS/TSGC-0329213v8d0

KeywordsGSM,LTE,UMTS

ETSI

650 Route des Lucioles
F-06921 Sophia Antipolis Cedex - FRANCE

Tel.: +33 4 92 94 42 00 Fax: +33 4 93 65 47 16

Siret N° 348 623 562 00017 - NAF 742 C
Association à but non lucratif enregistrée à la
Sous-Préfecture de Grasse (06) N° 7803/88

Important notice

Individual copies of the present document can be downloaded from:

<http://www.etsi.org>

The present document may be made available in more than one electronic version or in print. In any case of existing or perceived difference in contents between such versions, the reference version is the Portable Document Format (PDF). In case of dispute, the reference shall be the printing on ETSI printers of the PDF version kept on a specific network drive within ETSI Secretariat.

Users of the present document should be aware that the document may be subject to revision or change of status. Information on the current status of this and other ETSI documents is available at

<http://portal.etsi.org/tb/status/status.asp>

If you find errors in the present document, please send your comment to one of the following services:

http://portal.etsi.org/chaicor/ETSI_support.asp

Copyright Notification

No part may be reproduced except as authorized by written permission.
The copyright and the foregoing restriction extend to reproduction in all media.

© European Telecommunications Standards Institute 2012.
All rights reserved.

DECT™, **PLUGTESTS™**, **UMTS™** and the ETSI logo are Trade Marks of ETSI registered for the benefit of its Members.
3GPP™ and **LTE™** are Trade Marks of ETSI registered for the benefit of its Members and
of the 3GPP Organizational Partners.
GSM® and the GSM logo are Trade Marks registered and owned by the GSM Association.

Intellectual Property Rights

IPRs essential or potentially essential to the present document may have been declared to ETSI. The information pertaining to these essential IPRs, if any, is publicly available for **ETSI members and non-members**, and can be found in ETSI SR 000 314: *"Intellectual Property Rights (IPRs); Essential, or potentially Essential, IPRs notified to ETSI in respect of ETSI standards"*, which is available from the ETSI Secretariat. Latest updates are available on the ETSI Web server (<http://ipr.etsi.org>).

Pursuant to the ETSI IPR Policy, no investigation, including IPR searches, has been carried out by ETSI. No guarantee can be given as to the existence of other IPRs not referenced in ETSI SR 000 314 (or the updates on the ETSI Web server) which are, or may be, or may become, essential to the present document.

Foreword

This Technical Specification (TS) has been produced by ETSI 3rd Generation Partnership Project (3GPP).

The present document may refer to technical specifications or reports using their 3GPP identities, UMTS identities or GSM identities. These should be interpreted as being references to the corresponding ETSI deliverables.

The cross reference between GSM, UMTS, 3GPP and ETSI identities can be found under <http://webapp.etsi.org/key/queryform.asp>.

Contents

Intellectual Property Rights	2
Foreword.....	2
Foreword.....	6
1 Scope	7
2 References	7
3 Definitions and abbreviations.....	8
3.1 Definitions	8
3.2 Abbreviations	8
4 Signalling Flows over Gx, Gxx, Rx and S9	9
4.0 General	9
4.1 IP-CAN Session Establishment.....	9
4.2 IP-CAN Session Termination.....	12
4.2.1 UE-Initiated	12
4.2.1.1 AF located in the HPLMN	12
4.2.1.2 AF located in the VPLMN	14
4.2.2 PCEF-Initiated	16
4.2.2.1 AF located in the HPLMN	16
4.2.2.2 AF located in the VPLMN	18
4.2.3 PCRF-Initiated.....	19
4.2.3.1 AF located in the HPLMN	19
4.2.3.2 AF located in the VPLMN	21
4.3 IP-CAN Session Modification.....	23
4.3.1 Network-Initiated IP-CAN Session Modification.....	23
4.3.1.1 Interactions between BBERF, PCEF and PCRF(PCC/QoS Rule Provisioning in PUSH mode).....	23
4.3.1.2 Interactions between PCRF, AF and SPR	26
4.3.1.2.1 AF Session Establishment	26
4.3.1.2.1.1 AF located in HPLMN	26
4.3.1.2.1.2 AF located in VPLMN	27
4.3.1.2.2 AF session modification	28
4.3.1.2.2.1 AF located in the HPLMN.....	28
4.3.1.2.2.2 AF located in the VPLMN.....	29
4.3.1.2.3 AF session termination	31
4.3.1.2.3.1 AF located in the HPLMN.....	31
4.3.1.2.3.2 AF located in the VPLMN.....	32
4.3.2 PCEF -Initiated IP-CAN Session Modification (PCC Rule Provisioning in PULL Mode).....	32
4.3.2.1 PCEF-initiated IP-CAN Session Modification, AF located in HPLMN.	32
4.3.2.2 PCEF-initiated IP-CAN Session Modification, AF located in the VPLMN	35
4.4 Gateway Control Session Procedures.....	36
4.4.1 Gateway Control Session Establishment	37
4.4.2 Gateway Control and QoS Rules Request	41
4.4.2.1 Non-Roaming and Home Routed cases.....	41
4.4.2.2 Visited access cases.....	43
4.4.3 Gateway Control and QoS Rules Provision.....	44
4.4.4 Gateway Control Session Termination	45
4.4.4.1 BBERF-Initiated Gateway Control Session Termination	45
4.4.4.2 PCRF-Initiated Gateway Control Session Termination	47
4.5 Multiple BBERF Signalling Flows	48
4.5.1 Non-Roaming and Home Routed cases	48
4.5.1.1 New Gateway Control Session Establishment	48
4.5.1.2 PCEF IP-CAN session modification - Handover	51
4.5.2 Visited access case.....	52
4.5.2.1 New Gateway Control Session Establishment	52
4.5.2.2 PCEF-Initiated IP-CAN session modification-Handover.....	54

5	Binding Mechanism	56
5.1	Overview	56
5.2	Session Binding	57
5.3	PCC Rule Authorization and QoS Rule Generation	57
5.4	Bearer Binding	58
6	QoS Parameters Mapping	58
6.1	Overview	58
6.1.1	UE-Initiated IP-CAN bearers	60
6.1.2	Network-Initiated IP-CAN bearers	61
6.2	QoS parameter mapping Functions at AF	62
6.3	QoS parameter mapping Functions at PCRF	68
6.4	QoS parameter mapping Functions at PCEF	73
6.4.1	GPRS	73
6.4.1.1	Authorized IP QoS parameters per PDP Context to Authorized UMTS QoS parameters mapping in GGSN	73
6.4.1.2	Comparing UMTS QoS Parameters against the Authorized UMTS QoS parameters in GGSN for UE initiated PDP context	74
6.4.2	3GPP- EPS	75
6.4.2.1	Authorized IP QoS parameters per PDP Context to Authorized UMTS QoS parameters mapping in P-GW.	75
6.4.2.2	Comparing UMTS QoS Parameters against the Authorized UMTS QoS parameters in P-GW for UE initiated PDP context	77
6.5	QoS parameter mapping Functions at UE for a UE-initiated GPRS PDP Context	77
6.5.1	SDP to UMTS QoS parameter mapping in UE	79
6.5.2	SDP parameters to Authorized UMTS QoS parameters mapping in UE	79
7	PCRF addressing	83
7.1	General	83
7.2	DRA Definition	83
7.3	DRA Procedures	83
7.3.1	General	83
7.3.2	DRA Information Storage	83
7.3.3	Capabilities Exchange	84
7.3.4	Redirect DRA	84
7.3.4.1	Redirecting Diameter Requests	84
7.3.4.2	DRA binding removal	84
7.3.5	Proxy DRA	84
7.3.6	PCRF selection by BBERF/PCEF (non-roaming case)	85
7.3.7	PCRF selection by AF	85
7.3.8	PCRF selection in a roaming scenario	86
7.4	DRA flows	86
7.4.1	Proxy DRA	86
7.4.1.1	Establishment of Diameter Sessions	86
7.4.1.1.1	Non-roaming cases	86
7.4.1.1.2	Roaming cases	87
7.4.1.2	Modification of Diameter Sessions	88
7.4.1.2.1	Non-roaming cases	88
7.4.1.2.1.1	Client-initiated	88
7.4.1.2.1.2	PCRF-initiated	89
7.4.1.2.2	Roaming cases	90
7.4.1.2.2.1	V-PCRF initiated	90
7.4.1.2.2.2	H-PCRF initiated	91
7.4.1.3	Termination of Diameter Sessions	92
7.4.1.3.1	Non-roaming cases	92
7.4.1.3.2	Roaming cases	93
7.4.2	Redirect DRA	94
7.4.2.1	Establishment of Diameter Sessions	94
7.4.2.1.1	Non-roaming cases	94
7.4.2.1.2	Roaming cases	95
7.4.2.2	Modification of Diameter sessions	96
7.4.2.3	Termination of Diameter Sessions	97

7.4.2.3.1	Non-roaming cases	97
7.4.2.3.2	Roaming cases	98
Annex A (informative):	Examples of deriving the Maximum Authorized parameters from the SDP parameters	99
Annex B (normative):	Signalling Flows for IMS.....	100
B.1	Subscription to Notification of Signalling Path Status at IMS Registration	101
B.1a	Subscription to Notification of Change of IP-CAN Type at IMS Registration.....	101
B.2	IMS Session Establishment	102
B.2.1	Provisioning of service information at Originating P-CSCF and PCRF	102
B.2.2	Provisioning of service information at terminating P-CSCF and PCRF	104
B.3	IMS Session Modification.....	107
B.3.1	Provisioning of service information	107
B.3.2	Enabling of IP Flows.....	110
B.3.3	Disabling of IP Flows.....	111
B.3.4	Media Component Removal.....	112
B.4	IMS Session Termination	113
B.4.1	Mobile initiated session release / Network initiated session release.....	113
B.4.2	IP-CAN Bearer Release/Loss	114
Annex C (normative):	NAT Related Procedures.....	115
C.1	Support for media traversal of NATs using ICE	115
C.2	P-CSCF procedures	115
C.2.1	General	115
C.2.2	Deriving the UEs IP address.....	116
C.2.3	Deriving flow descriptions	116
C.2.4	Gating control.....	116
C.2.5	Bandwidth impacts	116
C.3	PCRF procedures.....	117
C.3.1	General	117
C.3.2	Deriving additional flow descriptions	117
C.3.3	Gating control.....	117
C.3.4	Bandwidth impacts	117
Annex D (normative):	Access specific procedures for GPRS.....	118
D.1	General.....	118
D.2	Binding Mechanisms	118
D.3	PCC Procedures	118
D.3.1	IP-CAN Session Modification.....	118
D.3.1.1	Network-initiated IP-CAN Session Modification.....	118
D.3.1.2	PCEF-initiated IP-CAN Session Modification	119
D.3.1.2.1	UE-initiated IP-CAN Bearer Establishment or IP-CAN Bearer Modification.....	119
D.3.1.2.2	UE-initiated IP-CAN Bearer Termination	122
Annex E (informative):	Change history	125
History		128

Foreword

This Technical Specification has been produced by the 3rd Generation Partnership Project (3GPP).

The contents of the present document are subject to continuing work within the TSG and may change following formal TSG approval. Should the TSG modify the contents of the present document, it will be re-released by the TSG with an identifying change of release date and an increase in version number as follows:

Version x.y.z

where:

- x the first digit:
 - 1 presented to TSG for information;
 - 2 presented to TSG for approval;
 - 3 or greater indicates TSG approved document under change control.
- y the second digit is incremented for all changes of substance, i.e. technical enhancements, corrections, updates, etc.
- z the third digit is incremented when editorial only changes have been incorporated in the document.

1 Scope

The present specification adds detailed flows of Policy and Charging Control (PCC) over the Rx , Gx, Gxx and S9 reference points and their relationship with the bearer level signalling flows over the Gn/Gp, S4, S5/S8, S2a and S2c interfaces.

The calls flows depicted in this Technical Specification represent usual cases, i.e. not all situations are covered. Detailed information provided in 3GPP TS 29.212 [9], 3GPP TS 29.214 [10], and 3GPP TS 29.215 [22] shall be taken into consideration.

The present specification also describes the binding and the mapping of QoS parameters among SDP, UMTS QoS parameters, and QoS authorization parameters.

The present specification also describes the PCRF addressing using DRA.

2 References

The following documents contain provisions which, through reference in this text, constitute provisions of the present document.

- References are either specific (identified by date of publication and/or edition number or version number) or non-specific.
- For a specific reference, subsequent revisions do not apply.
- For a non-specific reference, the latest version applies. In the case of a reference to a 3GPP document (including a GSM document), a non-specific reference implicitly refers to the latest version of that document *in the same Release as the present document*.

- [1] 3GPP TR 21.905: "Vocabulary for 3GPP Specifications".
- [2] 3GPP TS 23.203: "Policy Control and charging architecture".
- [3] 3GPP TS 23.060: "General Packet Radio Service (GPRS); Service description; Stage 2".
- [4] 3GPP TS 23.107: "Quality of Service (QoS) concept and architecture".
- [5] 3GPP TS 24.229: "IP Multimedia Call Control Protocol based on SIP and SDP; Stage 3".
- [6] 3GPP TS 26.234: "End-to-end transparent streaming service; Protocols and codecs".
- [7] 3GPP TS 26.236: "Packet switched conversational multimedia applications; Transport protocols".
- [8] 3GPP TS 29.207, version 6.5.0: "Policy control over Go interface".
- [9] 3GPP TS 29.212: "Policy and Charging Control over Gx reference point".
- [10] 3GPP TS 29.214: "Policy and Charging Control over Rx reference point".
- [11] IETF RFC 2327: "SDP: Session Description Protocol".
- [12] IETF RFC 3264: "An Offer/Answer model with the Session Description Protocol (SDP)".
- [13] IETF RFC 3556: "Session Description Protocol (SDP) Bandwidth Modifiers for RTP Control Protocol (RTCP) Bandwidth".
- [14] IETF RFC 3588: "Diameter Base Protocol".
- [15] IETF RFC 5245: "Interactive Connectivity Establishment (ICE): A Protocol for Network Address Translator (NAT) Traversal for Offer/Answer Protocols".
- [16] IETF RFC 4145: "TCP-Based Media Transport in the Session Description Protocol (SDP)".

- [17] IETF RFC 4975: "The Message Session Relay Protocol (MSRP)".
- [18] 3GPP2 C.S0046-0 v1.0: "3G Multimedia Streaming Services".
- [19] 3GPP2 C.S0055-A v1.0: "Packet Switched Video Telephony Services (PSVT/MCS)".
- [20] Void
- [21] 3GPP TS 23.402: "Architecture Enhancements for non-3GPP accesses".
- [22] 3GPP TS 29.215: "Policy and Charging Control over S9 reference point".
- [23] IETF RFC 3890: "A Transport Independent Bandwidth Modifier for the Session Description Protocol (SDP)".
- [24] 3GPP TS 24.292: "IP Multimedia (IM) Core Network (CN) subsystem Centralized Services (ICS); Stage 3".
- [25] 3GPP TS 23.216: "Single Radio Voice Call Continuity (SRVCC); Stage 2"

3 Definitions and abbreviations

3.1 Definitions

For the purposes of the present document, the terms and definitions given in 3GPP TR 21.905 [1] and the following apply:

DRA binding: The PCRF routing information stored per UE or per PDN in the DRA, which include the user identity (UE NAI), the UE IPv4 address and/or IPv6 prefix, the APN (if available) and the selected PCRF identity for a certain IP-CAN Session.

Gateway Control Session: An association between a BBERF and a PCRF (when GTP is not used in the EPC), used for transferring access specific parameters, BBERF events and QoS rules between the PCRF and BBERF. In the context of this specification this is implemented by use of the Gxx procedures.

3.2 Abbreviations

For the purpose of the present document, the abbreviations given in 3GPP TR 21.905 [1] and the following apply:

AF	Application Function
ARP	Allocation and Retention Priority
AVP	Attribute-Value Pair
BBERF	Bearer Binding and Event Reporting Function
CoA	Care of Address/DRA Diameter Routing Agent
GBR	Guaranteed Bitrate
H-AF	Home AF
H-DRA	Home DRA
H-PCRF	Home PCRF
HPLMN	Home PLMN
MBR	Maximum Bitrate
PA	Proxy Agent
PCC	Policy and Charging Control
PCEF	Policy and Charging Enforcement Function
PCRF	Policy and Charging Rule Function
PGW	PDN-Gateway
QCI	QoS Class Identifier
SDF	Service Data Flow
V-AF	Visited AF
V-DRA	Visited DRA
V-PCRF	Visited PCRF

VPLMN

Visited PLMN

4 Signalling Flows over Gx, Gxx, Rx and S9

4.0 General

There are three distinct network scenarios for an IP-CAN Session:

Case 1. No Gateway Control Session is required, no Gateway Control Establishment occurs at all (e.g. 3GPP Access where GTP-based S5/S8 are employed).

Case 2. A Gateway Control Session is required. There are two subcases:

2a) The BBERF assigns a Care of Address (CoA) to the UE and establishes a Gateway Control Session prior to any IP-CAN session establishment that will apply for all IP-CAN sessions using that CoA.

2b) At IP-CAN session establishment a Gateway Control Session is required before the PCEF announces the IP-CAN Session to the PCRF. At BBERF change and pre-registration the Gateway Control Session shall match an IP-CAN session that the PCEF has already announced. Each IP-CAN session is handled in a separate Gateway Control Session.

The PCRF shall select whether case 2a or case 2b applies based on the information received in the Gateway Control Session Establishment. For a user identified with a Subscription-Id AVP, when the PDN identifier included as part of the Called-Station-Id AVP is received, case 2b applies. If not received, case 2a applies.

The following considerations shall be taken into account when interpreting the signalling flows:

- V-PCRF is included to also cover the roaming scenarios.
- H-PCRF will act as a PCRF for non-roaming UEs.
- The steps numbered as 'number+letter' (e.g. '3a') will be executed, for the roaming case, instead of steps numbered as 'number' (e.g. '3'), as indicated in the explanatory text below the signalling flows.

4.1 IP-CAN Session Establishment

This clause is applicable if a new IP-CAN Session is being established.

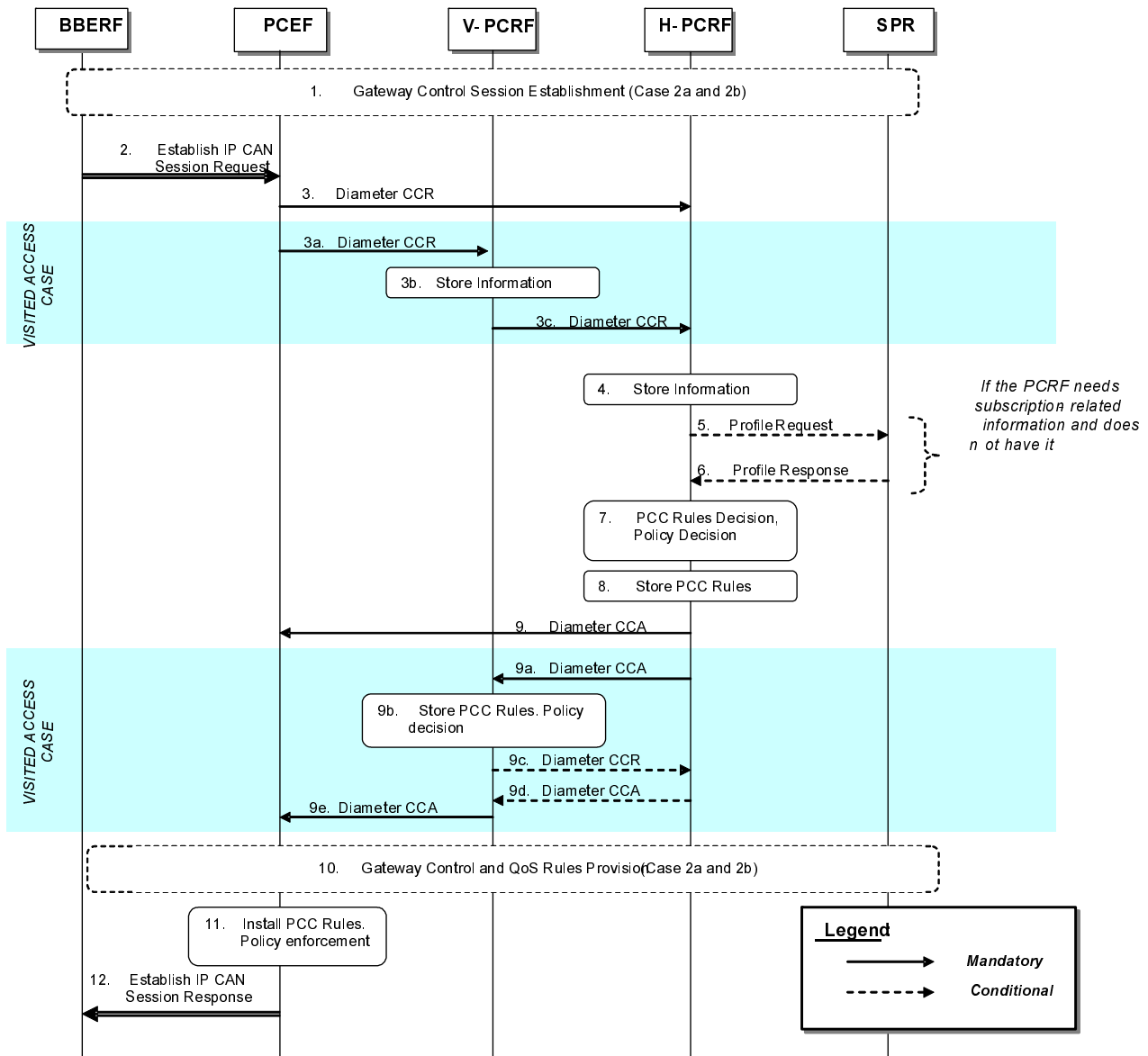

Figure 4.1.1: IP-CAN Session Establishment

1. The BBERF may initiate a Gateway Control Session Establishment procedure as defined in 4.4.1 (applicable for cases 2a during initial attach and 2b, as defined in clause 4.0), if appropriate. In this step, the PCRF determines whether the cases 2a or 2b applies, as defined in clause 4.0.
2. The PCEF receives an Establish IP-CAN Session Request. The form of the Establish IP-CAN Session Request depends upon the type of the IP-CAN. For GPRS, the GGSN receives the first Create PDP Context Request within an IP-CAN session. For I-WLAN, the GW receives an IPsec tunnel establishment request.
3. For the non-roaming case, and for the case when the UE is roaming in a Home-Routed scenario, the PCEF informs the H-PCRF of the IP-CAN Session establishment. The PCEF starts a new Gx session by sending a CCR to the H-PCRF using the CC-Request-Type AVP set to the value INITIAL_REQUEST. The PCEF provides UE identity information, PDN identifier, the UE IPv4 address and/or UE IPv6 address prefix and, if available, the IP-CAN type, RAT type and/or the default charging method. The PCEF provides, when available, the Default-EPS-Bearer-QoS and the APN-AMBR to the PCRF. For types of IP-CAN, where the H-PCRF can be in control of IP-CAN Bearers, e.g. GPRS, the PCEF also provides a new bearer identifier and information about the requested bearer, such as QoS. If applicable for the IP-CAN type, it will also provide information to indicate whether NW-initiated bearer control procedures are supported, if available. The PCRF links the Gx session for the new IP-CAN session with the corresponding Gateway Control Session as defined in clause 4.0. The PCRF maintains aligned set of PCC and QoS rules in the PCEF and BBERF(s) as applicable for the case.

For the case when the UE is roaming in a Visited Access scenario, steps 3a~3c are executed instead of step 3.

- 3a. The PCEF informs the V-PCRF of the establishment of the IP-CAN session. The PCEF starts a new Gx session by sending a CCR to the V-PCRF with the CC-Request-Type AVP set to the value INITIAL_REQUEST. The parameters for CCR as listed in step 3 are applicable here.
- 3b. The V-PCRF determines that the request is for a roaming user and concludes the IP-CAN session uses visited access. V-PCRF stores the received information.
- 3c. If there is not an already established S9 session for this roaming user, the V-PCRF sends a CCR to the H-PCRF with the CC-Request-Type AVP set to the value INITIAL_REQUEST. The V-PCRF includes the Subsession-Enforcement-Info AVP within the CCR with a new S9 subsession identifier assigned by the V-PCRF to this IP-CAN session within the Subsession-Id AVP, and the Subsession-Operation AVP set to the value ESTABLISHMENT.

If there is an already established S9 session for this roaming user, the V-PCRF sends a CCR to the H-PCRF with the CC-Request-Type AVP set to the value UPDATE_REQUEST. The V-PCRF includes the Subsession-Enforcement-Info AVP within the CCR with a new S9 subsession identifier assigned by the V-PCRF to this IP-CAN session within the Subsession-Id AVP, and the Subsession-Operation AVP set to the value ESTABLISHMENT.

4. The H-PCRF stores the information received in the CCR. For cases 2a and 2b, the H-PCRF links the Gx session with the Gateway Control Session(s).

NOTE 1: In the case 2a, when an additional PDN connection is established, the Gx session is linked with the already established Gateway Control Session.

5. If the H-PCRF requires subscription-related information and does not have it, the H-PCRF sends a request to the SPR in order to receive the information.
6. The SPR replies with the subscription related information containing the information about the allowed service(s), QoS information and PCC Rules information.

NOTE 2: For steps 5 and 6: The details associated with the Sp reference point are not specified in this Release. The SPR's relation to existing subscriber databases is not specified in this Release.

7. The H-PCRF selects or generates PCC Rule(s) to be installed. The H-PCRF may also make a policy decision by deriving an authorized QoS and by deciding whether service flows described in the PCC Rules are to be enabled or disabled.
8. The H-PCRF stores the selected PCC Rules. The H-PCRF selects the Bearer Control Mode that will apply during the IP-CAN session if applicable for the particular IP-CAN. If the H-PCRF controls the binding of IP-CAN Bearers, the H-PCRF stores information about the IP-CAN Bearer to which the PCC Rules have been assigned. If the BBERF/PCEF controls the binding of IP-CAN bearers, the H-PCRF may derive the QoS information per QCI applicable to that IP-CAN session for non-GBR bearers.
9. For the non-roaming case, and for the case when the UE is roaming in a Home-Routed scenario, the H-PCRF provisions the PCC Rules to the PCEF using CCA. The H-PCRF also provides the selected Bearer Control Mode if applicable for the particular IP-CAN and if available, the QoS information per QCI. The PCRF may also provide event triggers listing events for which the PCRF desires PCC Rule Requests. Furthermore, the PCRF may provide authorized QoS including the APN-AMBR and the Default-EPS-Bearer-QoS.

For types of IP-CAN, where the PCRF controls IP-CAN Bearers, e.g. GPRS, the PCRF indicates the IP-CAN Bearer where the PCC Rules are to be installed and that the authorized QoS refers to. Otherwise, the PCRF operates without any further reference to any specific bearer.

If online charging is applicable then the PCEF requests credit information from the OCS over the Gy interface. If the PCEF receives credit re-authorisation triggers from the OCS then, for case 2b, it requests the PCRF via a CCR message to provision the triggers at the BBERF. The triggers to be provisioned are specified in the Event-Report-Indication AVP in the CCR message. The CSG-Information-Reporting AVP is included if already provisioned at the PCEF.

For the case when the UE is roaming in a Visited Access scenario, steps 9a~9e are executed.

- 9a. The PCC Rules are provisioned by the H-PCRF to the V-PCRF by using a CCA. The H-PCRF includes PCC Rules in the Subsession-Decision AVP of the CCA, along with the S9 subsession identifier as received in step 3c within the Subsession-Id AVP. Other parameters listed in step 9 are also applicable here.
- 9b. The V-PCRF enforces visited operator policies regarding QoS authorization requested by the H-PCRF as indicated by the roaming agreements.
- 9c. The V-PCRF informs the H-PCRF when a request has been denied and may provide the acceptable QoS Information for the service.
- 9d. The H-PCRF acknowledges the CCR and may additionally include new or modified PCC rules to the V-PCRF.
- 9e. The V-PCRF provisions PCC rules to the PCEF by using CCA. The parameters listed in step 9a are applicable here.

NOTE 3: From this point and onward, the PCRF is responsible for keeping the active PCC and QoS rules aligned.

10. If case 2a or 2b applies, the PCRF aligns the set of QoS rules at the BBERF with the set of active rules at the PCEF.
11. The PCEF installs the received PCC Rules. The PCEF also enforces the authorized QoS and enables or disables service flows according to the flow status of the corresponding PCC Rules. If QoS information is received per QCI, PCEF sets the upper limit accordingly for the MBR that the PCEF assigns to the non-GBR bearer(s) for that QCI.
12. The PCEF sends a response to the Establish IP-CAN Session Request.
For GPRS, the GGSN accepts the PDP Context Request based on the results of the authorisation policy decision enforcement. If the requested QoS parameters do not correspond to the authorized QoS, the GGSN adjusts (downgrades /upgrades) the requested UMTS QoS parameters to the authorized values.

NOTE 4: The PCRF can reject the IP-CAN session establishment, e.g. the PCRF cannot obtain the subscription-related information from the SPR and the PCRF cannot make the PCC rule decisions, as described in 3GPP TS 29.212 [9].

The PCEF can also reject the IP-CAN session establishment, e.g. there is no activated/installed PCC rule for the IP-CAN session as specified in 3GPP TS 23.203 [2].

4.2 IP-CAN Session Termination

4.2.1 UE-Initiated

4.2.1.1 AF located in the HPLMN

This clause is applicable if an IP-CAN Session is being released by the UE and the AF is located in the HPLMN.

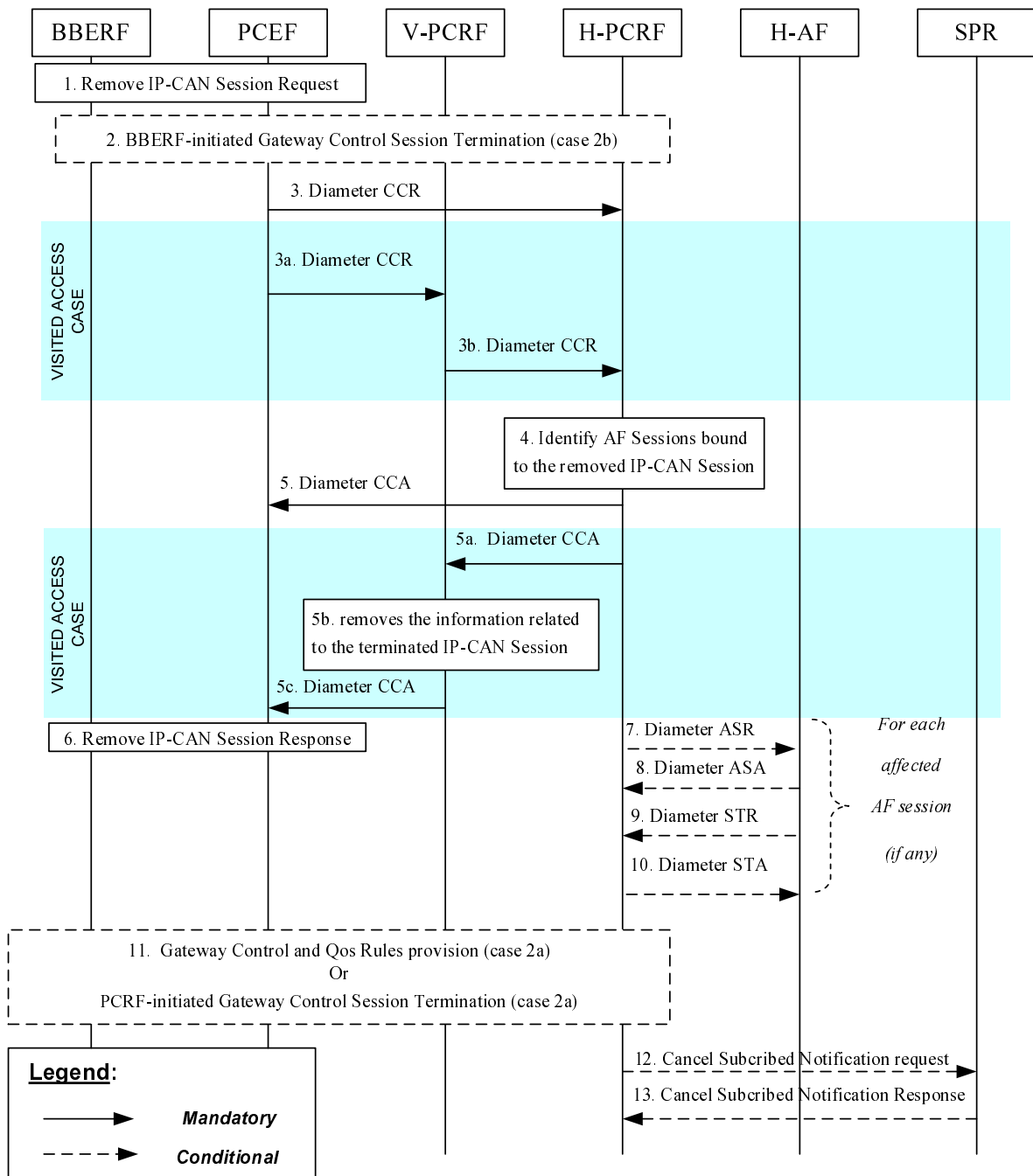

Figure 4.2.1.1.1: UE-Initiated IP-CAN Session Termination – AF located in the HPLMN

In the following procedures, the V-PCRF is included to depict the roaming scenarios. H-PCRF acts as the PCRF for non-roaming UEs.

1. If case 2b applies (as defined in clause 4.0), the BBERF receives a request to remove the IP-CAN session. In case 2a, the request goes transparently through the BBERF. In all cases, the PCEF receives a request to remove the IP-CAN Session. The form of the Remove IP-CAN Session Request depends upon the type of the IP-CAN. For GPRS, the GGSN receives a Delete PDP Context Request for the last PDP context within an IP-CAN session. For I-WLAN, the GW receives an IPsec tunnel termination request.
2. If case 2b applies (as defined in clause 4.0), the BBERF-initiated Gateway Control Session Termination procedure as defined in clause 4.4.4 (BBERF-Initiated Gateway Control Session Termination) is initiated.
3. For the non-roaming case, and for the case when the UE is roaming in a Home Routed scenario, the PCEF sends a CCR to the H-PCRF, indicating the IP-CAN Session termination. The PCEF requests the termination of the Gx session using the CC-Request-Type AVP set to the value TERMINATION_REQUEST.

For the case when the UE is roaming in a Visited Access scenario, steps 3a~3b are executed instead of step 3:

- 3a. The PCEF sends a CCR to the V-PCRF, indicating the IP-CAN Session termination. The PCEF requests the termination of the Gx session using the CC-Request-Type AVP set to the value TERMINATION_REQUEST.
- 3b. The V-PCRF sends the CCR to the H-PCRF. If case 2b or case 1 applies and this is the last subsession associated with the S9 session, the V-PCRF sends a CCR to the H-PCRF to request the termination of the S9 session using the CC-Request-Type AVP set to the value TERMINATION_REQUEST. Otherwise, the V-PCRF sends a CCR to the H-PCRF with a CC-Request-Type AVP set to the value UPDATE_REQUEST and a Subsession-Enforcement-Info within which the Subsession-Operation AVP set to value TERMINATION to request the termination of the corresponding S9 subsession.
4. The H-PCRF identifies the AF sessions that are bound to IP flows of the removed IP-CAN Session.
5. For the non-roaming case, and for the case when the UE is roaming in a Home Routed scenario, the H-PCRF acknowledges the Gx session termination by sending a CCA to the PCEF.

For the case when the UE is roaming in a Visited Access scenario, steps 5a~5c are executed instead of step 5:

- 5a. The H-PCRF acknowledges the S9 session or subsession termination by sending a CCA to the V-PCRF.
- 5b. The V-PCRF removes the information related to the terminated IP-CAN Session.
- 5c. The V-PCRF acknowledges the Gx session termination by sending a CCA to the PCEF.
6. The PCEF sends a response to the Remove IP-CAN Session Request. The form of the Remove IP-CAN Session Response depends upon the type of the IP-CAN. For GPRS, the GGSN sends a Delete PDP Context Response for the last PDP context within an IP-CAN session. For I-WLAN, the GW sends an IPsec tunnel termination response. Step 6 may be executed in parallel with step 3 or 3a (as applicable).

For each AF session identified in step 4 as bound to the IP-CAN Session being removed, steps 7-10 are executed:

7. The H-PCRF indicates the session abort to the H-AF by sending an ASR to the H-AF.
8. The H-AF responds by sending an ASA to the H-PCRF.
9. The H-AF sends an STR to the H-PCRF to indicate that the session has been terminated.
10. The H-PCRF responds by sending an STA to the H-AF.
11. If case 2a applies (as defined in clause 4.0), the Gateway Control and QoS Rules Provision procedure as defined in clause 4.4.3 (Gateway Control and QoS Rules Provision) may be initiated to remove the QoS rules associated with the IP-CAN session being terminated. This applies e.g. in case the Gateway Control Session remains to serve other IP-CAN sessions.

Alternatively, if UE acquires a care of address (CoA) that is used for the S2c reference point and the H-PCRF determines that all QoS rules are to be removed and the Gateway Control Session to be terminated, the PCRF-initiated Gateway Control Session Termination procedure as defined in clause 4.4.4 (PCRF-Initiated Gateway Control Session Termination) is initiated. This applies e.g. in case the UE is detached and the CoA acquired by the UE is not used for any other IP-CAN session.

12. The H-PCRF sends a cancellation notification request to the SPR if it has subscribed such notification. Step 12 may be initiated any time after step 5 or 5a (as applicable).
13. The SPR sends a response to the H-PCRF.

NOTE 3: For steps 12 and 13: The details associated with the Sp reference point are not specified in this Release. The SPR's relation to existing subscriber databases is not specified in this Release.

4.2.1.2 AF located in the VPLMN

This clause is applicable only for the Visited Access scenario for the case when an IP-CAN Session is being released by the UE and the AF is located in the VPLMN.

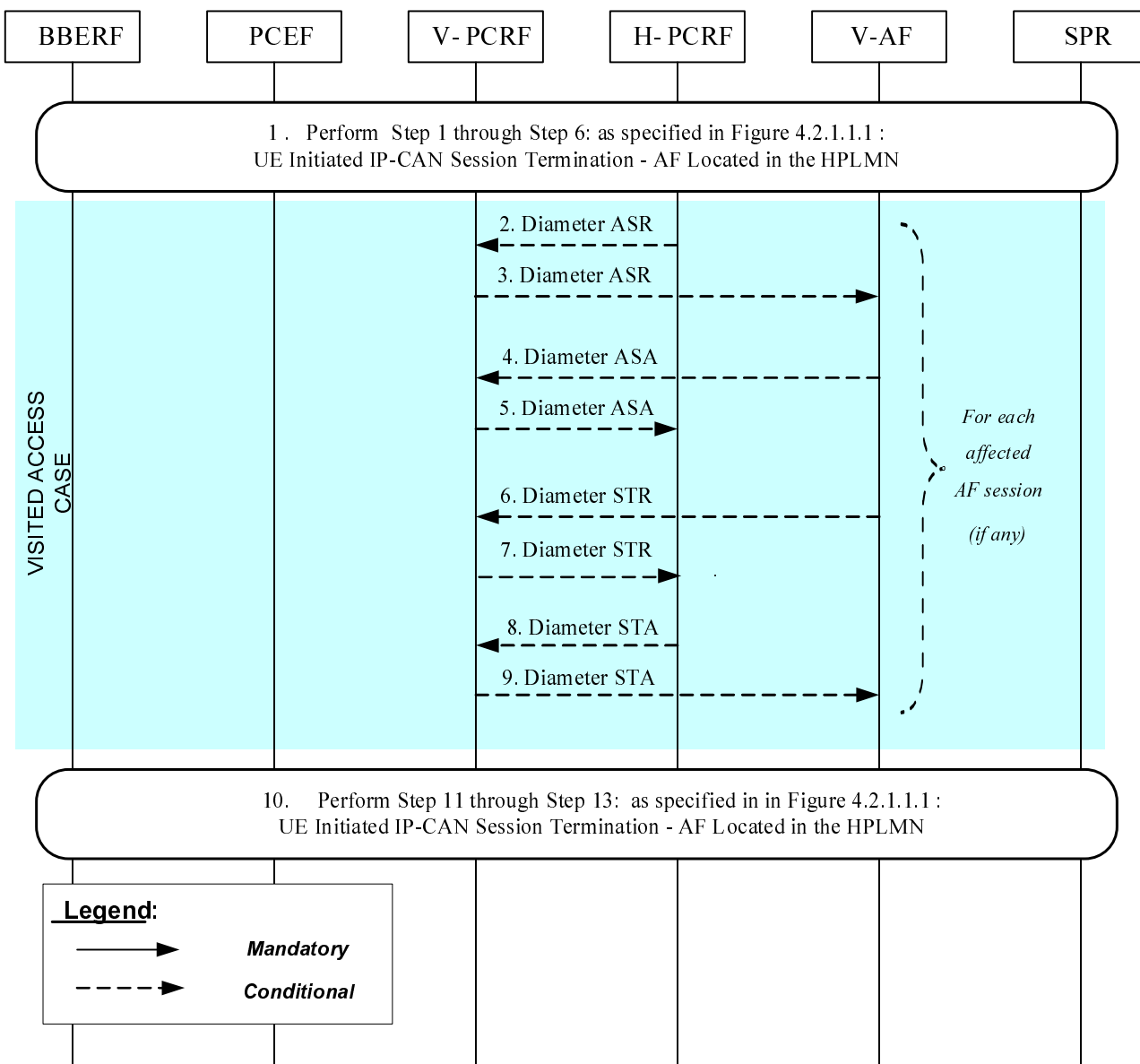

Figure 4.2.1.2.1: UE-Initiated IP-CAN Session Termination – AF located in the VPLMN

If the AF resides in the VPLMN, the V-PCRF proxies AF session signalling over S9 between the V-AF and the H-PCRF.

- In order to perform UE initiated IP-CAN Session Termination Procedures, step 1 thru step 6: as specified in Figure 4.2.1.1.1 : UE Initiated IP-CAN Session Termination - AF Located in the HPLMN are executed.
For each AF session identified in step 4 (Figure 4.2.1.1.1) as bound to the IP-CAN Session being removed steps 2-9 are executed:
- The H-PCRF indicates the session abort to the V-AF in VPLMN by sending an ASR to the V-PCRF.
- The V-PCRF proxies the ASR to the V-AF.
- The V-AF responds by sending an ASA to the V-PCRF.
- The V-PCRF proxies the ASA to the H-PCRF.
- The V-AF sends an STR to the V-PCRF to indicate that the session has been terminated.
- The V-PCRF proxies the STR to the H-PCRF.
- The H-PCRF responds by sending an STA to the V-PCRF.

9. The V-PCRF proxies the STA to the V-AF.
10. Step 11 thru step 13: as specified in Figure 4.2.1.1.1 : UE Initiated IP-CAN Session Termination - AF Located in the HPLMN are executed, as needed.

NOTE : For step 10: the details associated with the Sp reference point are not specified in this Release. The SPR"s relation to existing subscriber databases is not specified in this Release.

4.2.2 PCEF-Initiated

4.2.2.1 AF located in the HPLMN

This clause is applicable if an IP-CAN Session is being released by the PCEF and the AF is located in the HPLMN.

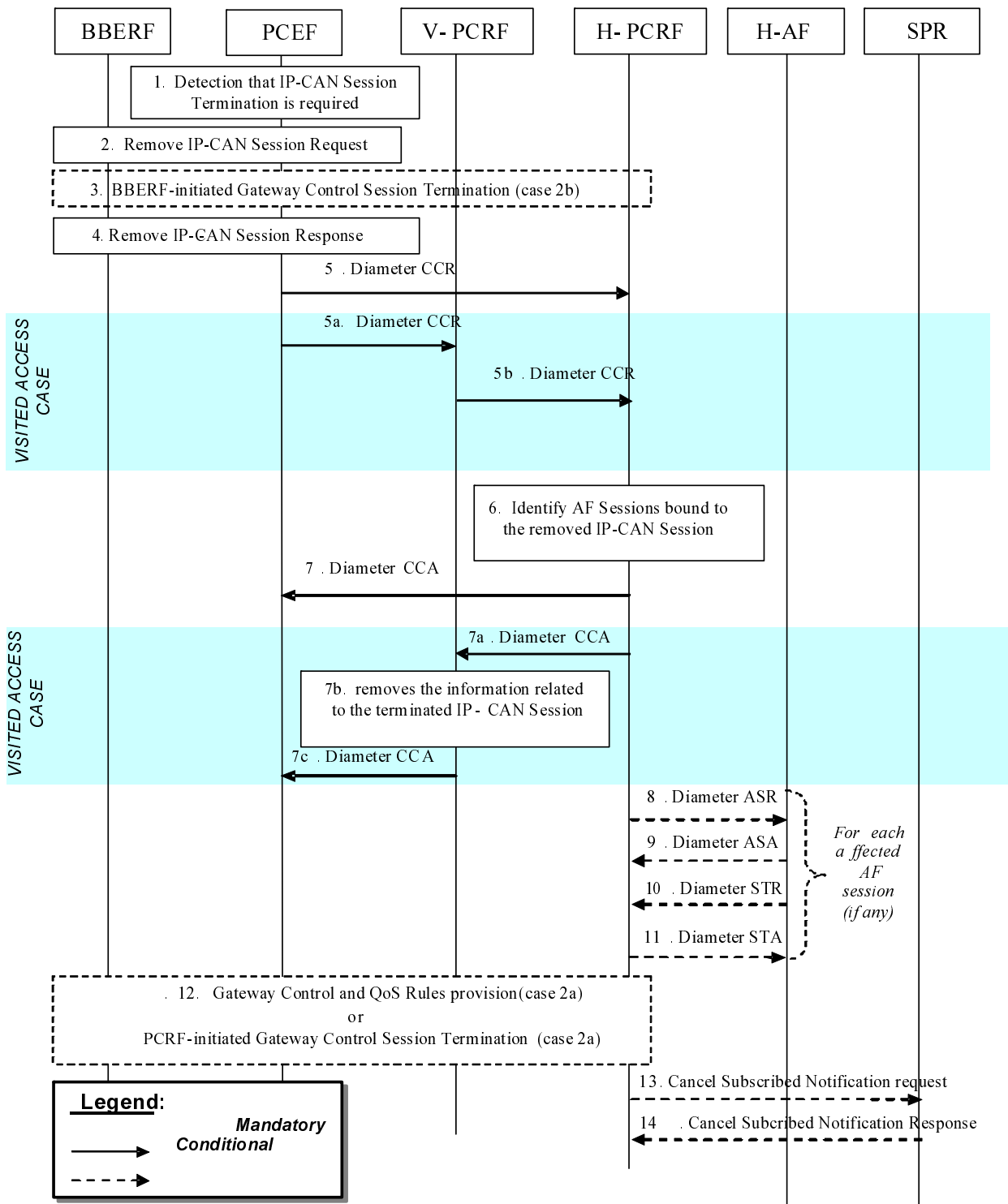

Figure 4.2.2.1.1 : PCEF-initiated IP-CAN Session Termination — AF located in the HPLMN

In the following procedures, the V-PCRF is included to depict the roaming scenarios. H-PCRF acts as the PCRF for non-roaming UEs.

1. The PCEF detects that the termination of an IP-CAN Session or bearer is required.
2. If case 2b applies (as defined in clause 4.0), PCEF sends the Remove IP-CAN Session Request to the BBERF. If case 2a applies (as defined in clause 4.0), the request goes transparently through the BBERF. In all cases, the PCEF sends a Remove IP-CAN Session Request to remove the IP-CAN Session. The form of the Remove IP-CAN Session Request depends upon the type of the IP-CAN. It can consist of separate requests for each IP-

CAN Bearer within an IP-CAN Session. For GPRS, the GGSN sends a separate Delete PDP Context Requests for each of the PDP contexts within an IP-CAN session. For I-WLAN, the GW sends an IPsec tunnel termination request.

3. If case 2b applies (as defined in clause 4.0), the BBERF-initiated Gateway Control Session Termination procedure as defined in clause 4.4.4 (BBERF-Initiated Gateway Control Session Termination) is initiated.
4. The PCEF receives a response to the Remove IP-CAN Session Request. For GPRS, the GGSN receives a Delete PDP Context Response for each PDP context within the IP-CAN session. For I-WLAN, the GW receives an IPsec tunnel termination response.

5 - 7. Same as Steps 3~5 in figure 4.2.1.1.1.

8 - 14. Same as Steps 7~13 in figure 4.2.1.1.1.

NOTE 1: Steps 2 and 5 may be executed in parallel.

4.2.2.2 AF located in the VPLMN

This clause is applicable only for the Visited Access scenario for the case when an IP-CAN Session is being released by the PCEF and the AF is located in the VPLMN

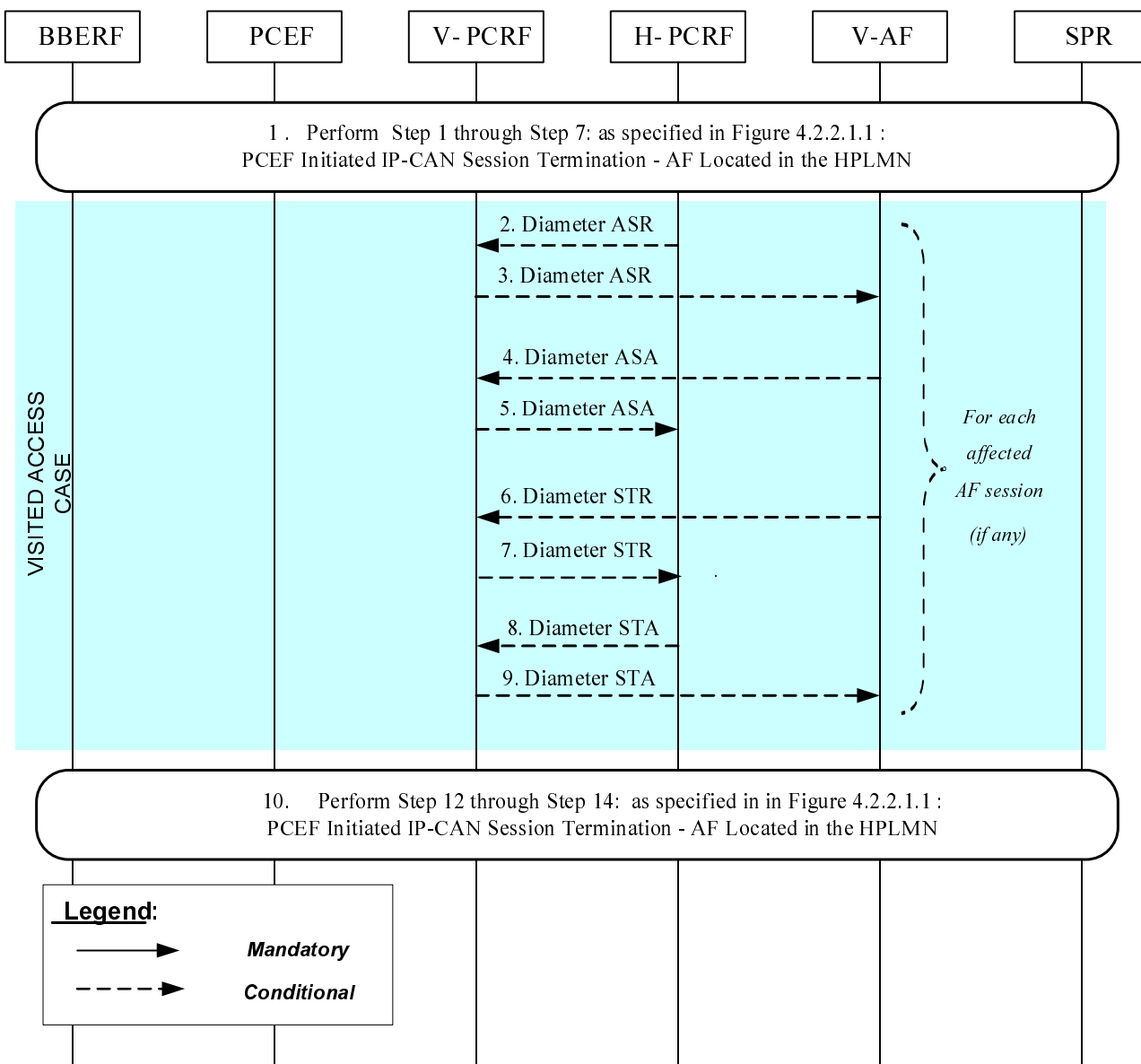

Figure 4.2.2.2.1: PCRF-Initiated IP-CAN Session Termination – AF located in the VPLMN

If the AF resides in the VPLMN, the V-PCRF proxies AF session signalling over S9 between the V-AF and the H-PCRF.

1. In order to perform PCEF initiated IP-CAN Session Termination Procedures, step 1 through step 7: as specified in Figure 4.2.2.1.1: PCEF Initiated IP-CAN Session Termination - AF Located in the HPLMN are executed.

For each AF session identified in step 6 (Figure 4.2.2.1.1) as bound to the IP-CAN Session being removed, steps 2-9 are executed:

2. The H-PCRF indicates the session abort to the V-AF in VPLMN by sending an ASR to the V-PCRF.
3. The V-PCRF proxies the ASR to the V-AF.
4. The V-AF responds by sending an ASA to the V-PCRF.
5. The V-PCRF proxies the ASA to the H-PCRF.
6. The V-AF sends an STR to the V-PCRF to indicate that the session has been terminated.
7. The V-PCRF proxies the STR to the H-PCRF.
8. The H-PCRF responds by sending an STA to the V-PCRF.
9. The V-PCRF proxies the STA to the V-AF.
10. Step 12 through step 14: as specified in Figure 4.2.2.1.1: PCEF Initiated IP-CAN Session Termination - AF Located in the HPLMN are executed, as needed.

NOTE : For step 10: the details associated with the Sp reference point are not specified in this Release. The SPR's relation to existing subscriber databases is not specified in this Release.

4.2.3 PCRF-Initiated

4.2.3.1 AF located in the HPLMN

This clause is applicable if an IP-CAN Session is being released by the PCRF and the AF is located in the HPLMN.

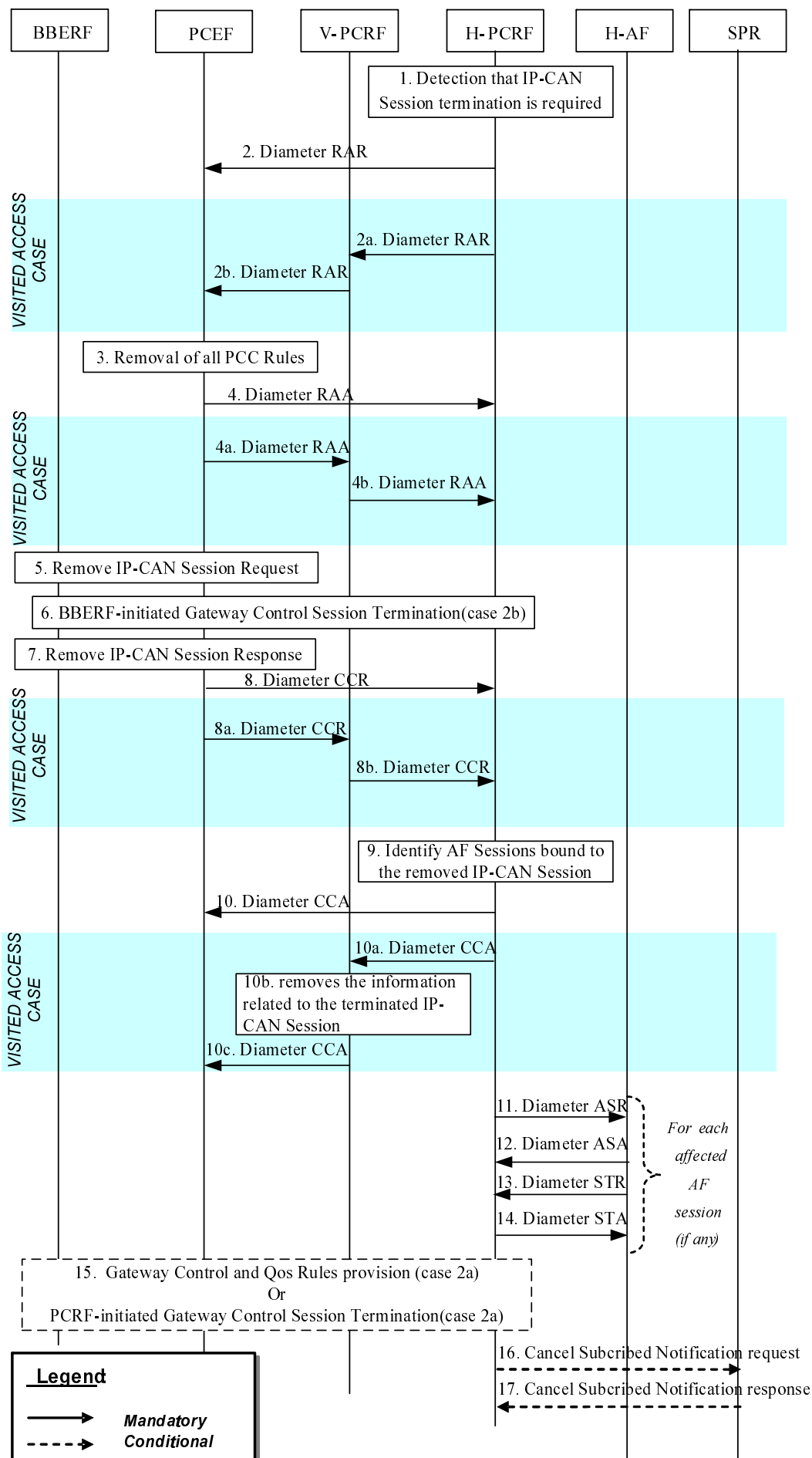

Figure 4.2.3.1.1: PCRF-initiated IP-CAN Session Termination – AF located in HPLMN

In the following procedures, the V-PCRF is included to depict the roaming scenarios. H-PCRF acts as the PCRF for non-roaming UEs.

1. The H-PCRF detects that the termination of an IP-CAN Session is required.
2. For the non-roaming case, and for the case when the UE is roaming in a Home Routed scenario, the H-PCRF sends a RAR including the Session-Release-Cause AVP to request that the PCEF terminates the IP CAN session.

For the case when the UE is roaming in a Visited Access scenario, steps 2a~2b are executed instead of step 2:

- 2a. If case 2b or case 1 applies and the subsession being terminated is the last subsession over S9, the H-PCRF sends a RAR including the Session-Release-Cause AVP to the V-PCRF to indicate the termination of the S9 session. Otherwise, the H-PCRF sends a RAR to the V-PCRF including the Subsession-Decision-Info AVP with the Session-Release-Cause AVP to indicate the request for terminating the S9 subsession corresponding to the IP-CAN session.
- 2b. The V-PCRF sends a RAR including the Session-Release-Cause AVP to the PCEF.
3. The PCEF removes all the PCC Rules which are applied to the IP CAN session.
4. For the non-roaming case, and for the case when the UE is roaming in a Home Routed scenario, the PCEF sends a RAA to acknowledge the RAR.
For the case when the UE is roaming in a Visited Access scenario, steps 4a~4b are executed instead of step 4:
 - 4a. The PCEF sends a RAA to the V-PCRF.
 - 4b. The V-PCRF sends a RAA to the H-PCRF and acknowledges the request for terminating the S9 session or the S9 subsession corresponding to the IP-CAN session.
5. The PCEF applies IP CAN specific procedures to terminate the IP CAN session.
6. - 17. Same as Steps 3-14 in figure 4.2.2.1.1.

4.2.3.2 AF located in the VPLMN

This clause is applicable only for the Visited Access scenario for the case when an IP-CAN Session is being released by the PCRF and the AF is located in the VPLMN

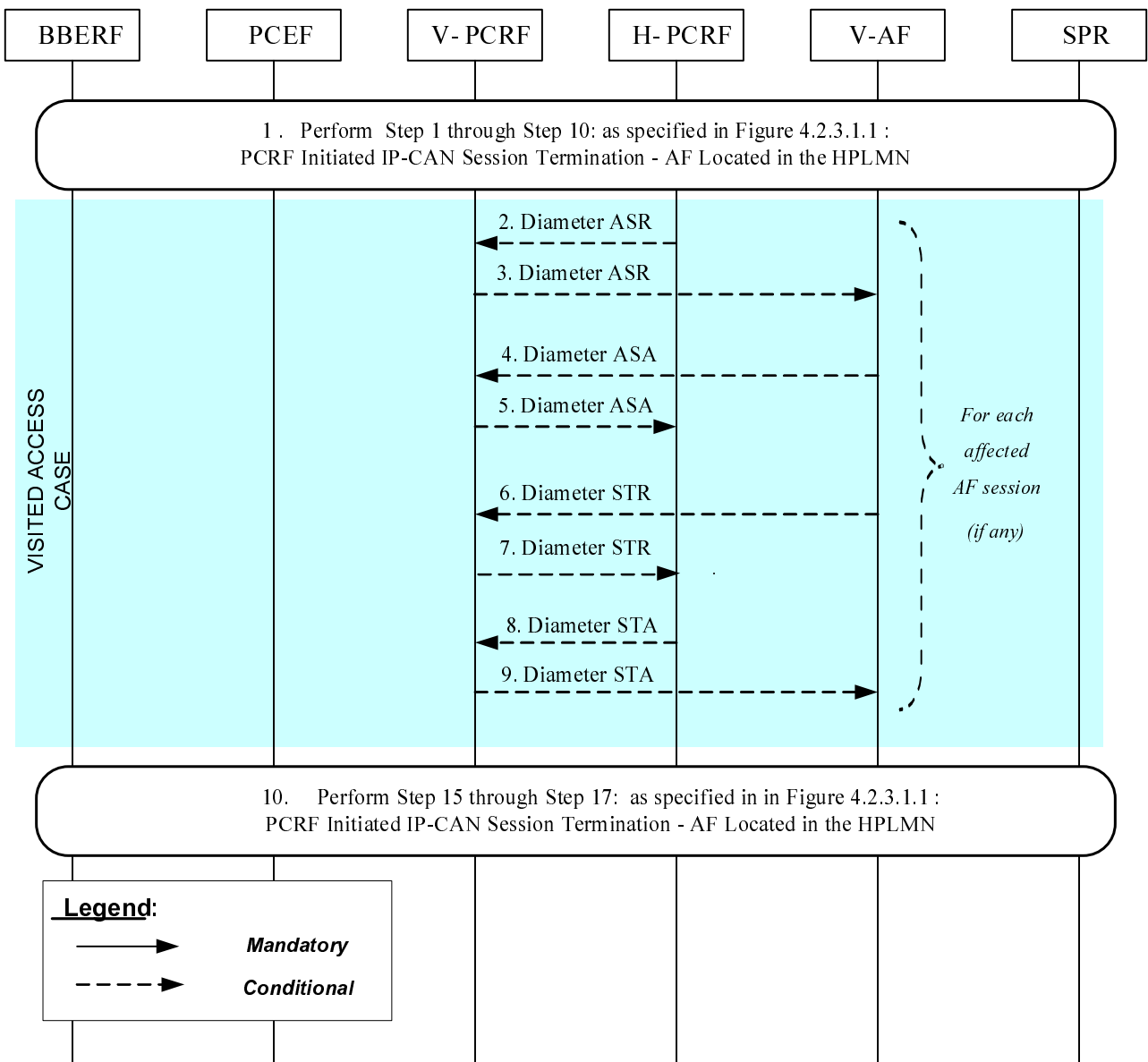

Figure 4.2.3.2.1: PCRF-Initiated IP-CAN Session Termination – AF located in the VPLMN

If the AF resides in the VPLMN, the V-PCRF proxies AF session signalling over S9 between the V-AF and the H-PCRF.

1. In order to perform PCRF initiated IP-CAN Session Termination Procedures, step 1 through step 10: as specified in Figure 4.2.3.1.1: PCRF Initiated IP-CAN Session Termination - AF Located in the HPLMN are executed.
For each AF session identified in step 6 (Figure 4.2.3.1.1) as bound to the IP-CAN Session being removed, steps 2-9 are executed:
2. The H-PCRF indicates the session abort to the V-AF in VPLMN by sending an ASR to the V-PCRF.
3. The V-PCRF proxies the ASR to the V-AF.
4. The V-AF responds by sending an ASA to the V-PCRF.
5. The V-PCRF proxies the ASA to the H-PCRF.
6. The V-AF sends an STR to the V-PCRF to indicate that the session has been terminated.
7. The V-PCRF proxies the STR to the H-PCRF.

8. The H-PCRF responds by sending an STA to the V-PCRF.
9. The V-PCRF proxies the STA to the V-AF.
10. Step 15 through step 17: as specified in Figure 4.2.3.1.1: PCRF Initiated IP-CAN Session Termination - AF Located in the HPLMN are executed, as needed.

NOTE: For step 10: the details associated with the Sp reference point are not specified in this Release. The SPR's relation to existing subscriber databases is not specified in this Release.

4.3 IP-CAN Session Modification

4.3.1 Network-Initiated IP-CAN Session Modification

4.3.1.1 Interactions between BBERF, PCEF and PCRF(PCC/QoS Rule Provisioning in PUSH mode)

This flow shows the provisioning of PCC/QoS Rules and/or authorized QoS triggered by an event in the PCRF.

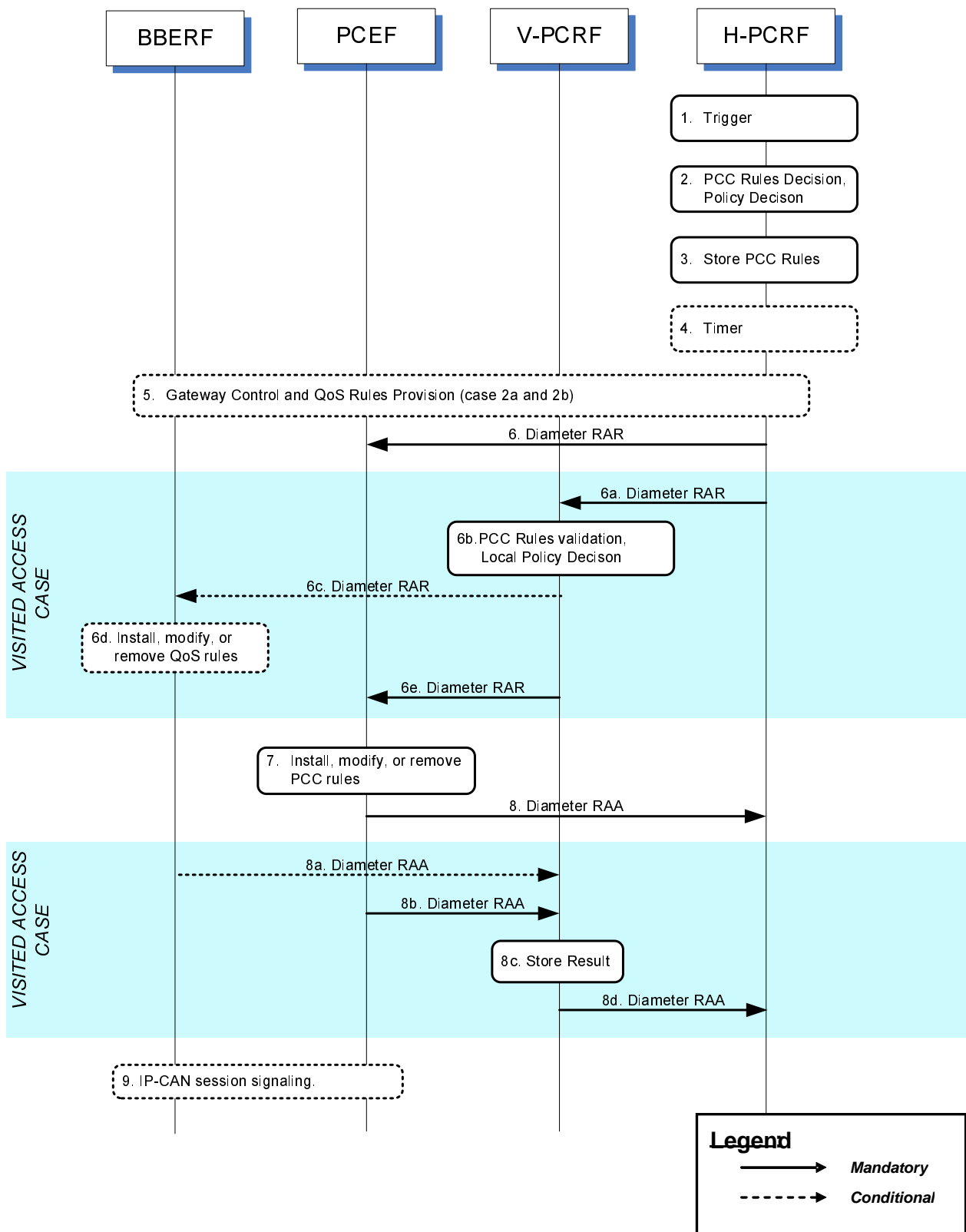

Figure 4.3.1.1.1: Interactions between BBERF, PCEF and PCRF for PCRF-Initiated IP-CAN Session Modification

1. The H-PCRF receives an internal or external trigger to re-evaluate PCC Rules and policy decision for an IP-CAN Session. Possible external trigger events are described in clause 4.3.1.2.

2. The H-PCRF selects the PCC Rule(s) to be installed, modified or removed for the IP-CAN Session. The H-PCRF may also update the policy decision by defining an authorized QoS and enable or disable the service flow(s) of PCC Rules. If the PCEF controls the binding of IP-CAN bearers, the H-PCRF may add or change QoS information per QCI applicable to that IP-CAN session.
3. The H-PCRF stores the updated PCC Rules.
4. Step 4 is only applicable if the Bearer Control Mode (BCM) selected is UE-only or, for UE/NW the H-PCRF determines that UE mode applies for the affected PCC Rules, and the PCRF receives an external trigger from the AF.
The PCRF may start a timer to wait for a UE requested bearer resource initiation, modification or removal procedure initiated by the UE, as depicted in figure 4.3.2.1.1.

If a UE requested bearer resource initiation, modification or termination procedure initiated by the terminal is received for the affected PCC rules while the timer is running, all subsequent steps in the present figure shall not be executed and, for case 1, the steps in figure 4.3.2.1.1 (on provisioning based on PULL procedure at PCEF - initiated IP-CAN session modification when the AF is located in the HPLMN), 4.3.2.2.1 (on provisioning based on PULL procedure at PCEF-initiated IP-CAN session modification when the AF is located in the VPLMN) and for cases 2a and 2b, the steps in figure 4.4.2.1.1 (Home Routed case) or 4.4.2.2.1 (Visited Access case) shall be executed instead.

Otherwise, if the BCM selected is UE/NW, the PCRF shall proceed with the subsequent steps (provisioning based on PUSH procedure) in the present figure after timer expiry.

5. For case 2a and 2b, if Gxx applies for the IP-CAN session and the user is not roaming, or the user is roaming in a Home Routed scenario or a Visited Access scenario for case 2a when the available QoS rule are not related to any IP-CAN session, the H-PCRF may initiate Gateway Control and QoS rules provisioning procedures described in clause 4.4.3.
6. The H-PCRF sends a Diameter RAR to request that the PCEF installs, modifies or removes PCC Rules and updates the policy decision.

When the UE is roaming in a Visited Access scenario, steps 6a ~ 6e are executed instead of step 6:

- 6a. The H-PCRF sends a Diameter RAR to the V-PCRF to request that the PCEF installs, modifies or removes PCC Rules and updates the policy decision.
- 6b. The V-PCRF enforces visited operator policies regarding PCC rules requested by the H-PCRF based on roaming agreements or locally configured policy.

NOTE: If the V-PCRF rejects provisioned PCC rules received from the H-PCRF, the remaining steps in this call flow are not followed. Instead, the V-PCRF shall notify the H-PCRF by sending a Diameter RAA, including the Experimental-Result-Code AVP set to the value PCC_RULE_EVENT, identify the failed PCC rules as specified in TS 29.212 [9], and additionally may provide the acceptable QoS Information for the service.

- 6c. For case 2a and 2b, V-PCRF will derive the QoS rules from the PCC rules. The V-PCRF will initiate a Gateway Control and QoS Rule procedure as described in clause 4.4.3 to install, modify or remove QoS rules and optionally subscribe to new events in the BBERF.
- 6d. The BBERF installs, modifies or removes the identified QoS Rules. The BBERF also enforces the authorized QoS of the corresponding QoS Rules.
- 6e. The V-PCRF sends a Diameter RAR to request that the PCEF installs, modifies or removes PCC Rules.
7. The PCEF installs, modifies or removes the identified PCC Rules. The PCEF also enforces the authorized QoS and enables or disables service flow according to the flow status of the corresponding PCC Rules. If QoS information is received per QCI, PCEF shall set/update the upper limit for the MBR that the PCEF assigns to the non-GBR bearer for that QCI.
8. The PCEF sends a Diameter RAA to acknowledge the RAR. The PCEF informs the H-PCRF about the outcome of the PCC rule operation

When the UE is roaming in a Visited Access scenario, steps 8a ~ 8d are executed instead of step 8:

- 8a. The BBERF informs the V-PCRF about the outcome of the operation by sending a Diameter RAA command.
- 8b. The PCEF informs the V-PCRF about the outcome of the PCC rule operation by sending a Diameter RAA command.
- 8c. The V-PCRF stores the received information.
- 8d. The V-PCRF informs the H-PCRF about the outcome of the operation by sending a Diameter RAA command.
- 9. When Gxx does not apply for the IP-CAN session, IP-CAN bearer signalling is executed separately for each IP-CAN bearer under the following conditions:
 - if all PCC rules bound to a bearer have been removed or deactivated (bearer deactivation is applicable)
 - if one or more bearers have to be modified
 - if the PCEF needs to establish a new bearer (bearer establishment is applicable).

4.3.1.2 Interactions between PCRF, AF and SPR

4.3.1.2.1 AF Session Establishment

4.3.1.2.1.1 AF located in HPLMN

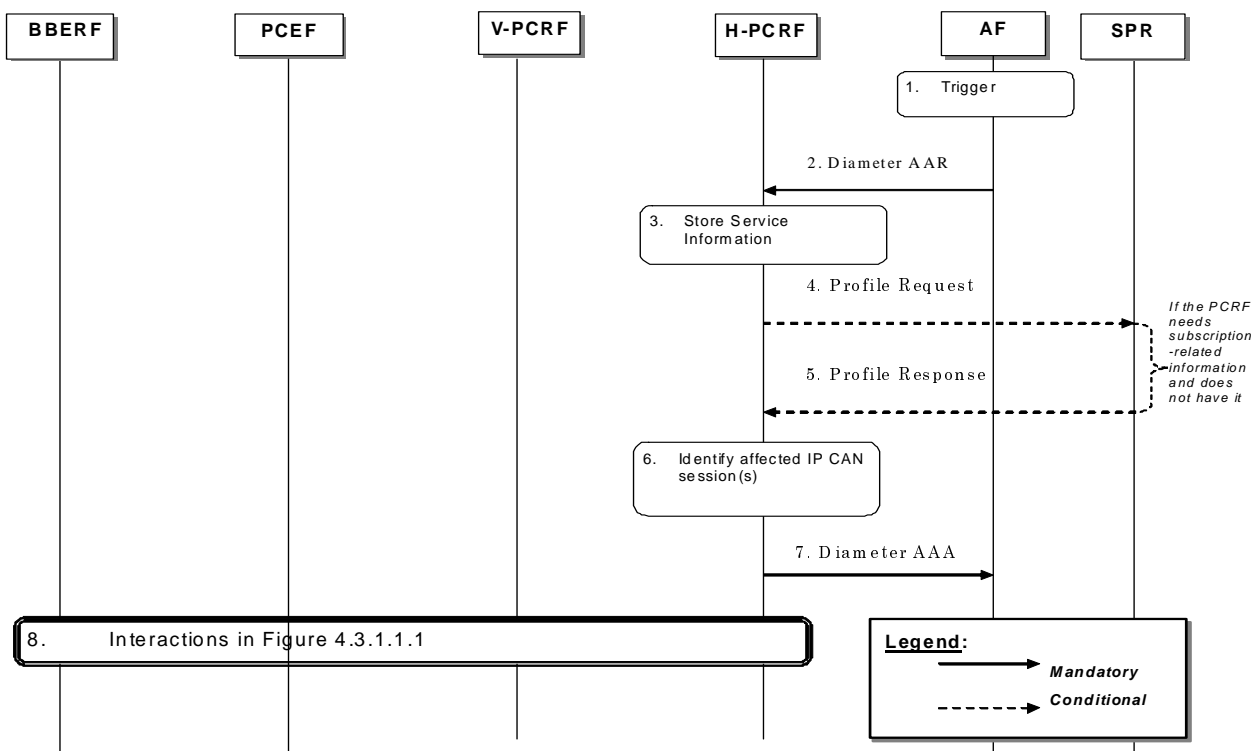

Figure 4.3.1.2.1.1.1: AF session establishment triggers PCRF-Initiated IP-CAN Session Modification (AF in HPLMN)

1. The AF receives an internal or external trigger to set-up a new AF session and provide Service Information. The AF identifies the Service Information needed (e.g. IP address of the IP flow (s), port numbers to be used, information on media types, etc).
2. The AF provides the Service Information to the H-PCRF by sending a Diameter AAR for a new Rx Diameter session.
3. The H-PCRF stores the received Service Information.

4. If the H-PCRF requires subscription related information and does not have it, the PCRF sends a request to the SPR in order to receive the information.
5. The SPR replies with the subscription related information containing the information about the allowed service(s), QoS information and PCC Rules information.

NOTE: For steps 4 and 5: The details associated with the Sp reference point are not specified in this Release. The SPR's relation to existing subscriber databases is not specified in this Release.

6. The H-PCRF identifies the affected established IP-CAN Session(s) using the information previously received from the PCEF/V-PCRF and the Service Information received from the AF.
7. The H-PCRF sends a Diameter AAA to the AF.
8. The H-PCRF interacts with the PCEF/BBERF/V-PCRF according to figure 4.3.1.1.1 (Interactions between BBERF/PCEF and PCRF for PCRF-Initiated IP-CAN Session Modification).

4.3.1.2.1.2 AF located in VPLMN

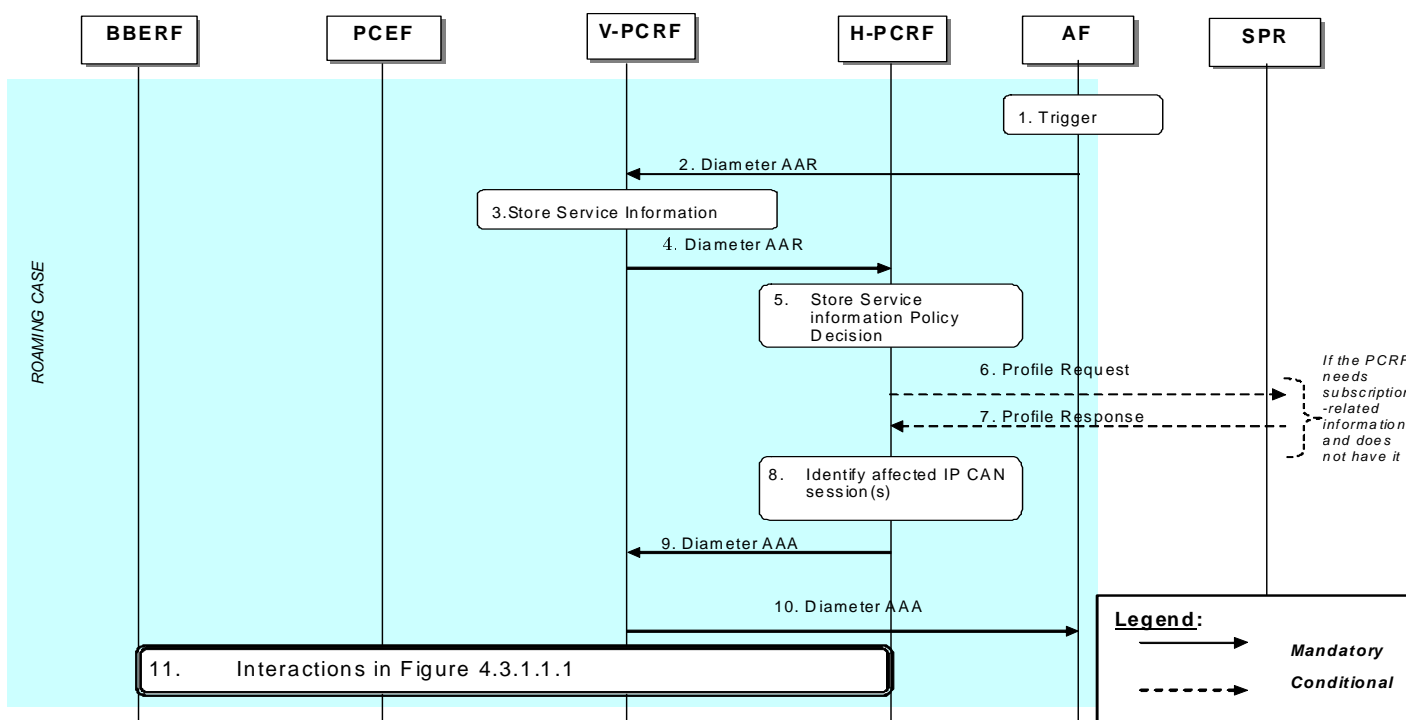

Figure 4.3.1.2.1.2.1: AF session establishment triggers PCRF-Initiated IP-CAN Session Modification (AF in VPLMN)

1. The AF receives an internal or external trigger to set-up a new AF session and provide Service Information. The AF identifies the Service Information needed (e.g. IP address of the IP flow (s), port numbers to be used, information on media types, etc).
2. The AF provides the Service Information to the V-PCRF by sending a Diameter AAR for a new Rx Diameter session.
3. The V-PCRF stores the Service Information.

NOTE: The V-PCRF may employ operator policies and reject the AAR from the AF if the provided Service Information is not acceptable. If this happens, the V-PCRF replies immediately to the AF, includes an unsuccessful Result-Code or Experimental-Result-Code in the AAA, and the remaining steps of this call flow are not carried out.

4. The V-PCRF forwards the Diameter AAR to the H-PCRF.

- 5. The H-PCRF stores the received Service Information.
- 6. If the H-PCRF requires subscription-related information and does not have it, the H-PCRF sends a request to the SPR in order to receive the information.
- 7. The SPR replies with the subscription related information containing the information about the allowed service(s), QoS information and PCC Rules information.

NOTE: For steps 6 and 7: The details associated with the Sp reference point are not specified in this Release. The SPR's relation to existing subscriber databases is not specified in this Release.

- 8. H-PCRF stores the Service Information and identifies the affected established IP-CAN Session (s) using the information previously received from the PCEF via the V-PCRF and the Service Information received from the AF.
- 9. The H-PCRF responds to the V-PCRF with a Diameter AAA.
- 10. The V-PCRF forwards the Diameter AAA to the AF.
- 11. The H-PCRF interacts with the PCEF/BBERF via the V-PCRF according to figure 4.3.1.1.1 (Interactions between BBERF/PCEF and PCRF for PCRF-Initiated IP-CAN Session Modification).

4.3.1.2.2 AF session modification

4.3.1.2.2.1 AF located in the HPLMN

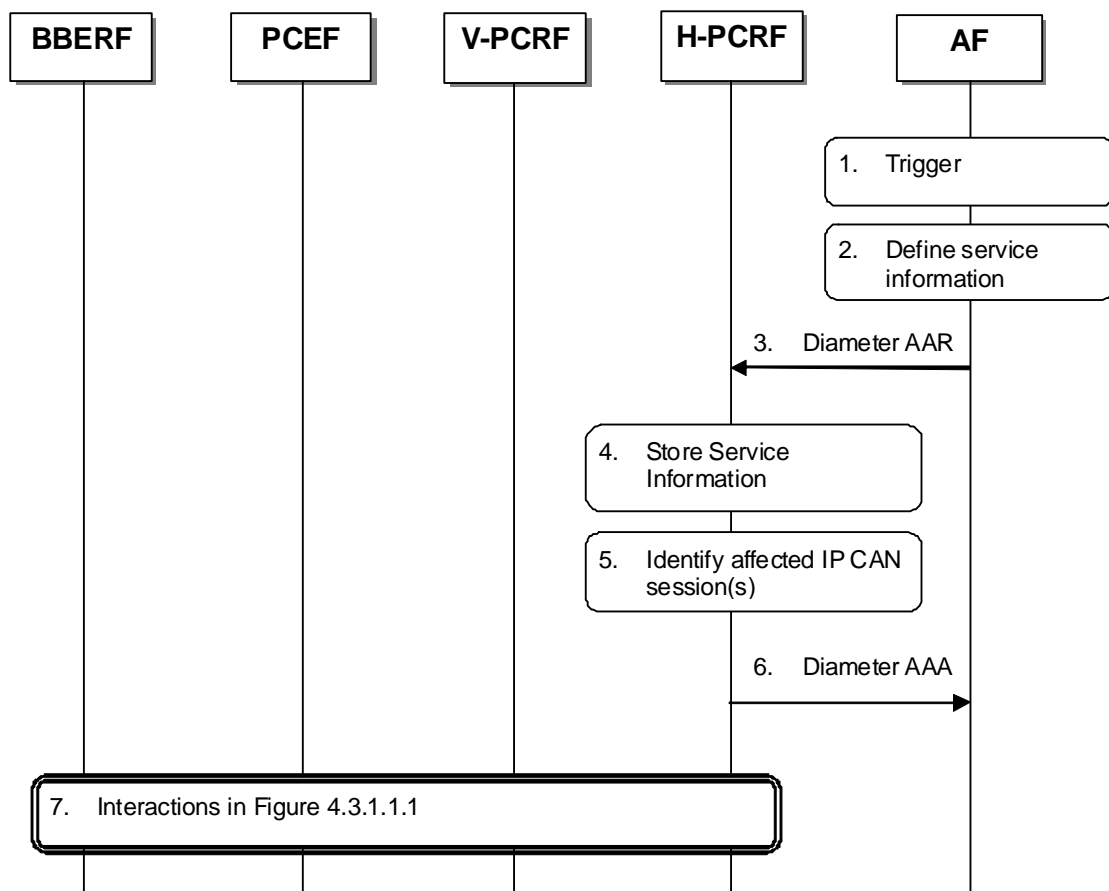

Figure 4.3.1.2.2.1.1: AF session modification triggers PCRF-Initiated IP-CAN Session Modification (AF in HPLMN)

1. The AF receives an internal or external trigger to modify an existing AF session and provide related Service Information.
2. The AF identifies the Service Information needed (e.g. IP address of the IP flow(s), port numbers to be used, information on media types, etc.).
3. The AF provides the Service Information to the H-PCRF by sending a Diameter AAR for the existing Rx Diameter session corresponding to the modified AF session.
4. The H-PCRF stores the received Service Information.
5. The H-PCRF identifies the affected established IP-CAN Session(s) using the information previously received from the PCEF/V-PCRF and the Service Information received from the AF.
6. The H-PCRF sends a Diameter AAA to the AF.
7. The H-PCRF interacts with the BBERF/PCEF/V-PCRF according to figure 4.3.1.1.1.

4.3.1.2.2.2 AF located in the VPLMN

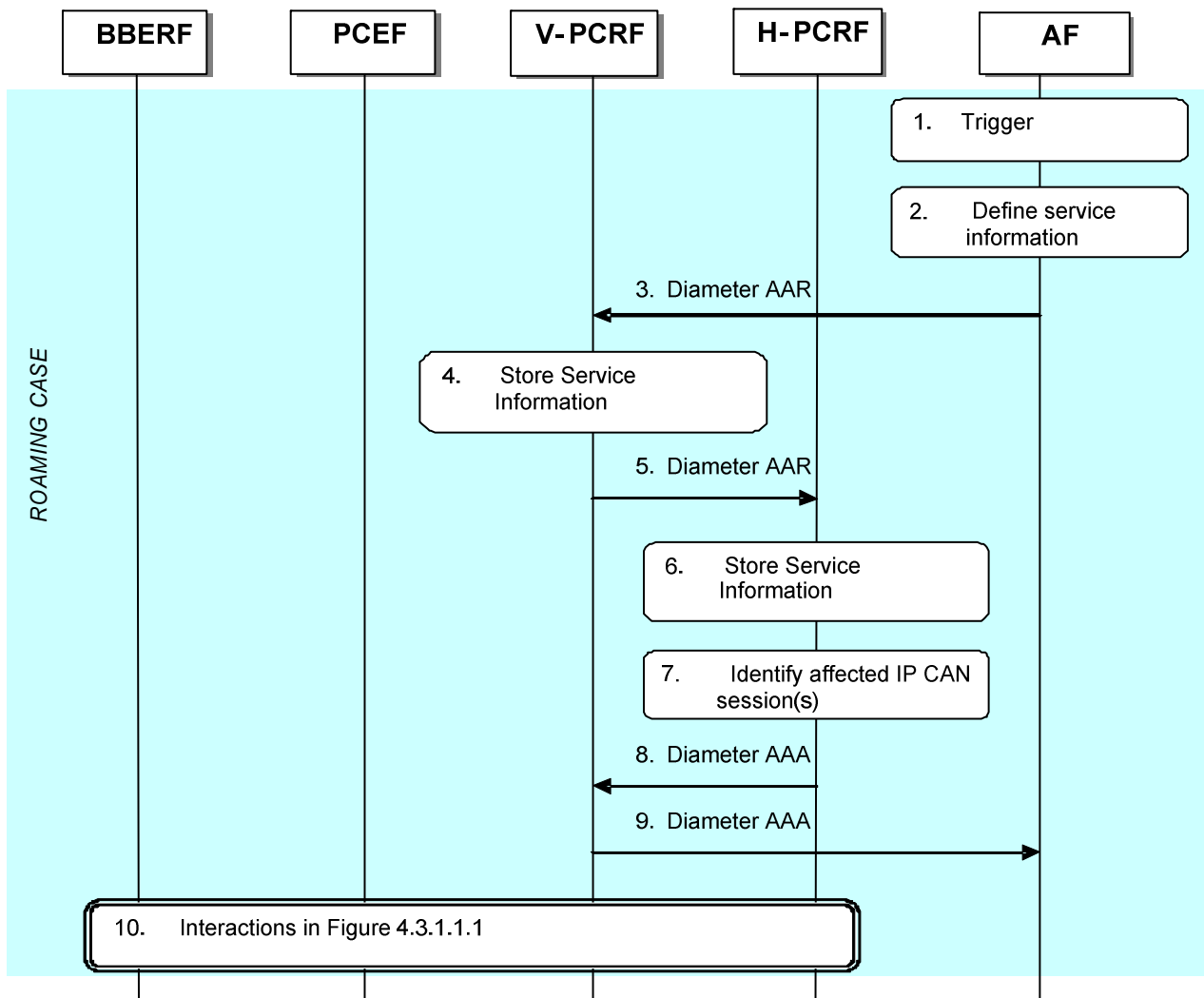

Figure 4.3.1.2.2.1 AF session modification triggers PCRF-Initiated IP-CAN Session Modification (AF in VPLMN)

1. The AF receives an internal or external trigger to modify an existing AF session and provide related Service Information.

2. The AF identifies the Service Information needed (e.g. IP address of the IP flow(s), port numbers to be used, information on media types, etc.).
3. The AF provides the Service Information to the V-PCRF by sending a Diameter AAR for the existing Rx Diameter session corresponding to the modified AF session.
4. The V-PCRF stores the received Service Information.

NOTE: The V-PCRF may employ operator policies and reject the AAR from the AF if the provided Service Information is not acceptable. If this happens, the V-PCRF replies immediately to the AF, includes an unsuccessful Result-Code or Experimental-Result-Code in the AAA, and the remaining steps of this call flow are not carried out.

5. The V-PCRF forwards the Diameter AAR to the H-PCRF.
6. The H-PCRF stores the received Service Information.
7. The H-PCRF identifies the affected established IP-CAN Session(s) using the information previously received from the PCEF/V-PCRF and the Service Information received from the AF.
8. The H-PCRF responds with a Diameter AAA.
9. The V-PCRF forwards the Diameter AAA to the AF.
10. The H-PCRF interacts with the BBERF/PCEF via the V-PCRF according to figure 4.3.1.1.1.

4.3.1.2.3 AF session termination

4.3.1.2.3.1 AF located in the HPLMN

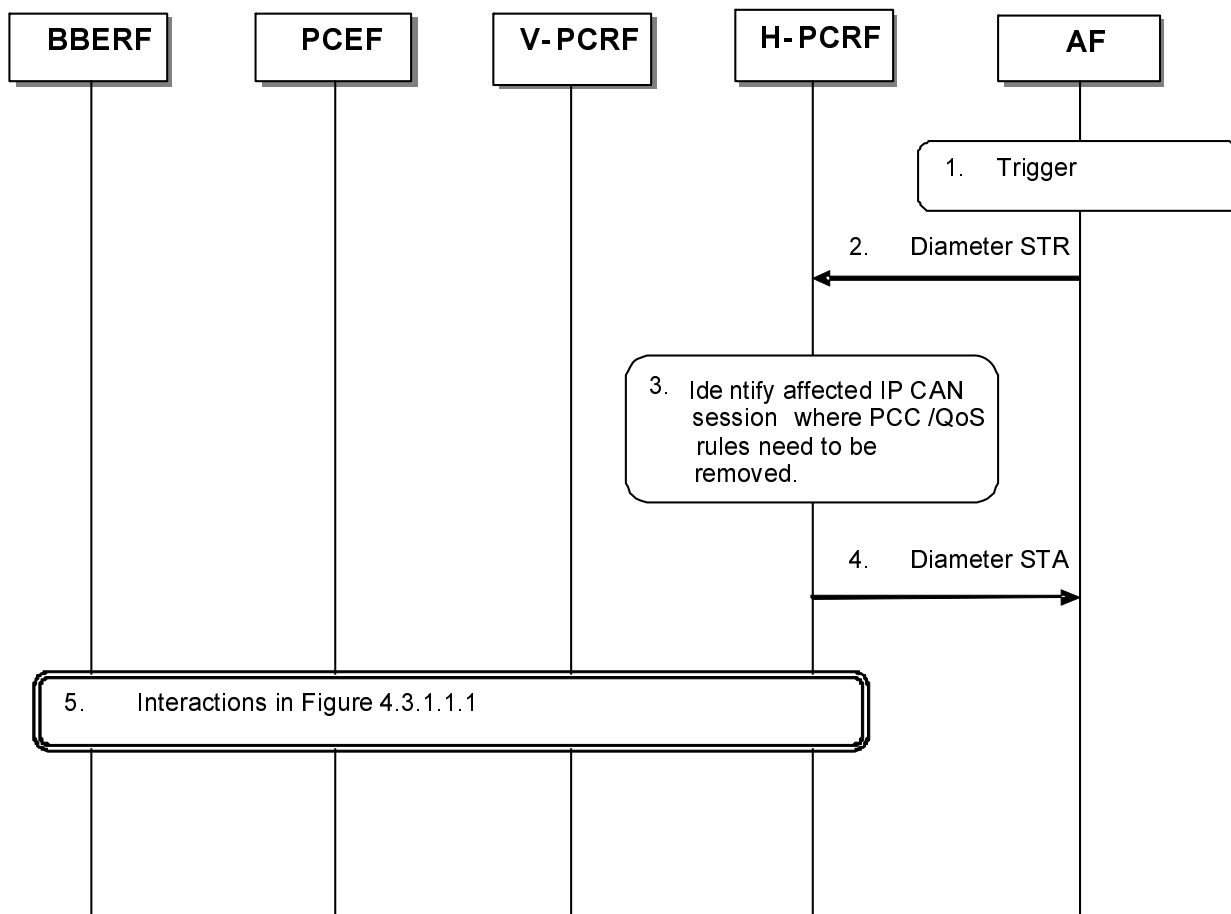

Figure 4.3.1.2.3.1.1: Removal of PCC/QoS Rules at AF session release (AF in HPLMN)

1. The AF receives an internal or external trigger for a session release.
2. The AF sends a session termination request, Diameter STR, to the H-PCRF to request the removal of the session.
3. The H-PCRF identifies the affected IP-CAN Session where PCC Rules and, if available, QoS Rules for the IP flow(s) of this AF session are installed. These PCC/QoS Rules need to be removed.
4. The H-PCRF sends Diameter STA, session termination answer, to the AF.
5. The H-PCRF interacts with the BBERF/PCEF/V-PCRF according to figure 4.3.1.1.1.

4.3.1.2.3.2 AF located in the VPLMN

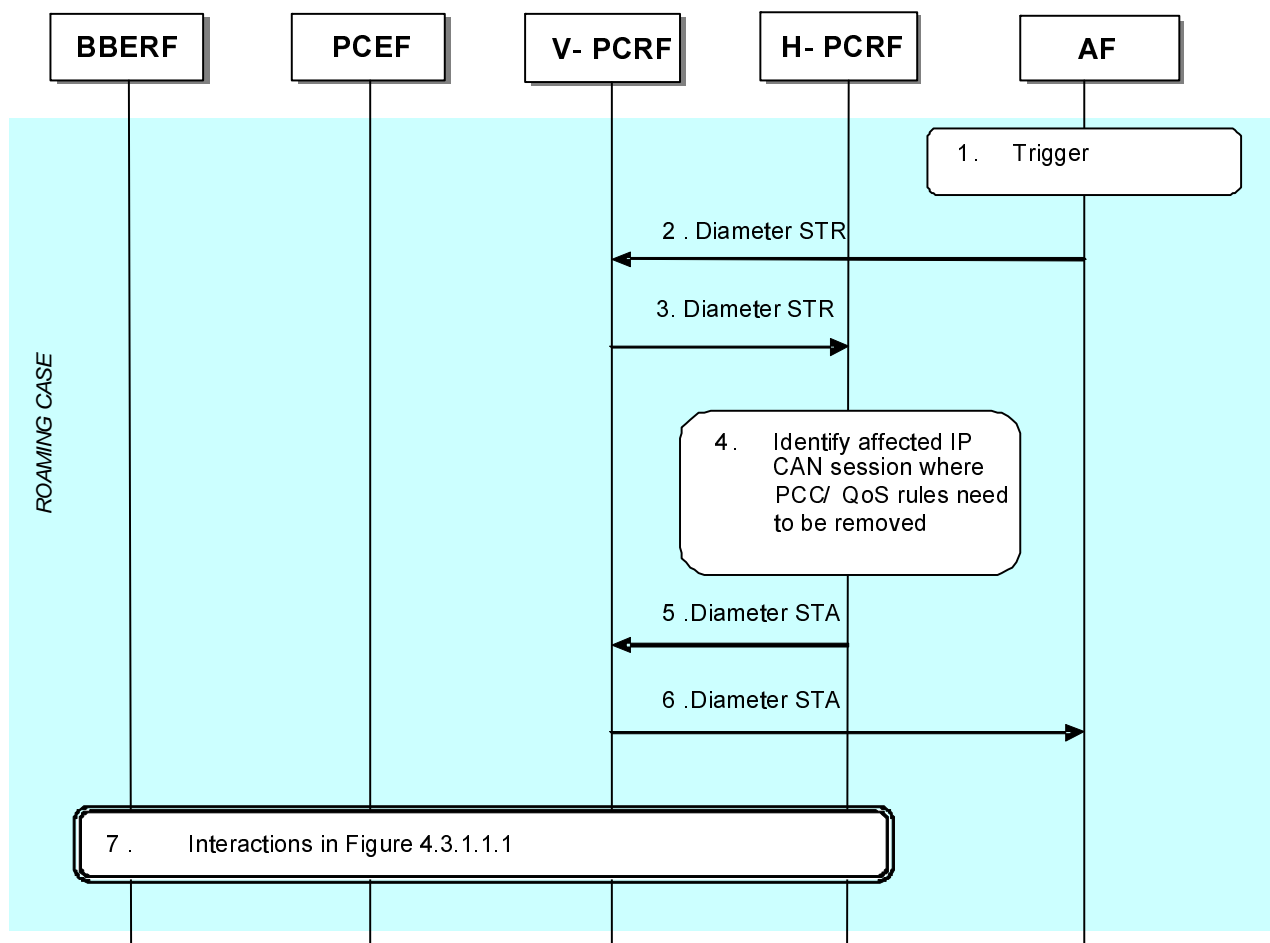

Figure 4.3.1.2.3.2.1: Removal of PCC/QoS Rules at AF session release (AF in VPLMN)

1. The AF receives an internal or external trigger for a session release.
2. The AF sends a session termination request, Diameter STR, to the V-PCRF to request the removal of the session.
3. The V-PCRF forwards the Diameter STR to the H-PCRF.
4. The H-PCRF identifies the affected IP-CAN Session where PCC Rules and, if available, QoS Rules for the IP flow(s) of this AF session are installed. These PCC/QoS Rules need to be removed.
5. The H-PCRF sends Diameter STA, session termination answer, to the V-PCRF.
6. The V-PCRF forwards the Diameter STA to the AF.
7. The H-PCRF interacts with the BBERF/PCEF via the V-PCRF according to figure 4.3.1.1.1.

4.3.2 PCEF -Initiated IP-CAN Session Modification (PCC Rule Provisioning in PULL Mode)

4.3.2.1 PCEF-initiated IP-CAN Session Modification, AF located in HPLMN.

This flow shows the provisioning of PCC Rules and/or authorized QoS triggered by the PCEF.

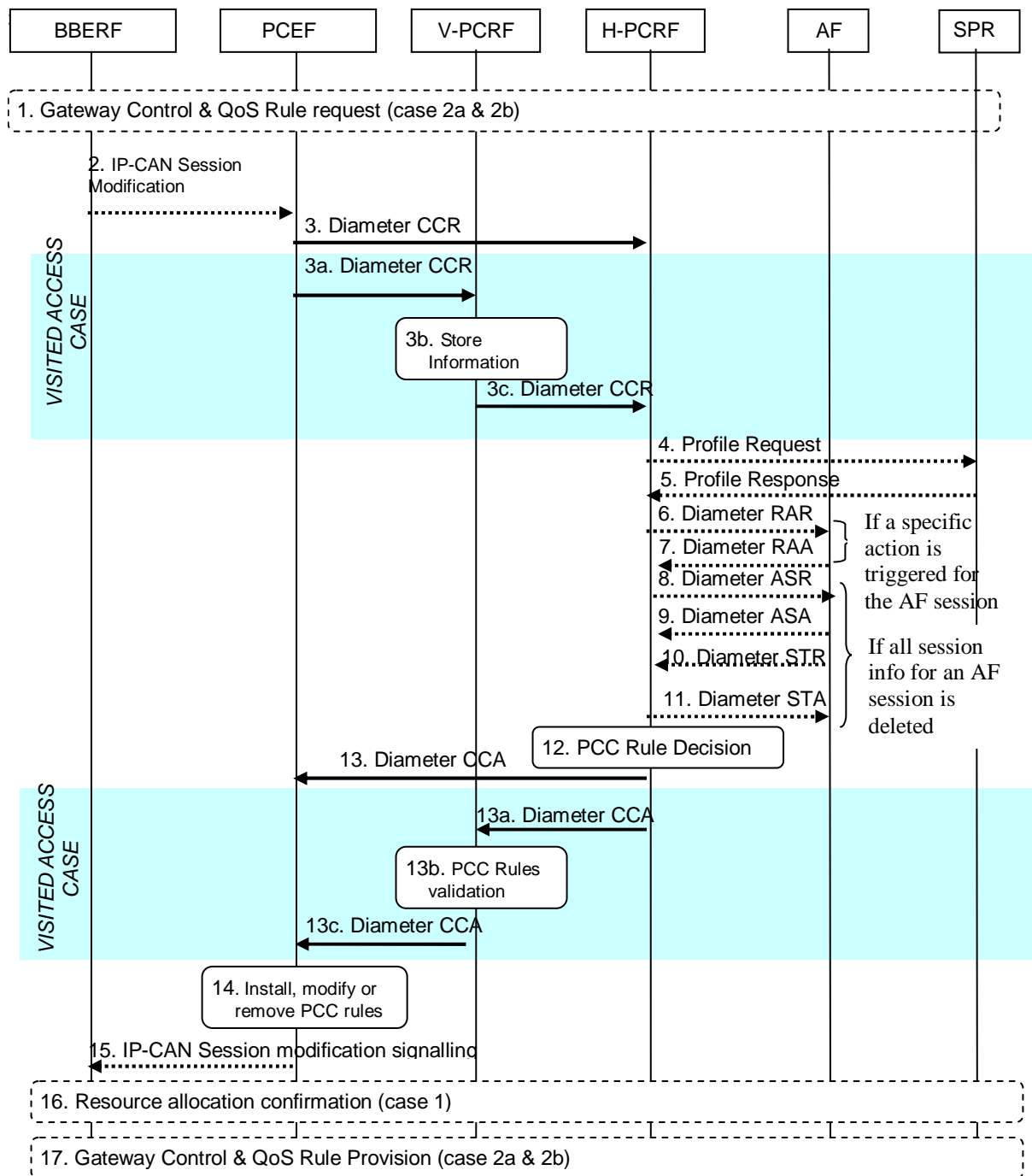

Figure 4.3.2.1.1: PCEF-initiated IP-CAN Session Modification. AF in HPLMN.

1. For case 2a and 2b, the BBERF may initiate Gateway Control and QoS rules request procedure described in clause 4.4.2.
2. The PCEF may receive a request for IP-CAN Session modification. The IP-CAN session modification can be initiated upon receiving UE-initiated resource modification request (case 1), a new IP-CAN bearer establishment signalling (case 1), due to a specific event (e.g. UE requested PDN connectivity in all cases) or an internal trigger.
3. The PCEF informs the H-PCRF about the IP-CAN session modification for non-roaming case and Home-Routed roaming scenario. The PCEF sends a CCR command to the H-PCRF including the CC-Request-Type AVP set to the value 'UPDATE_REQUEST'. For an IP-CAN Session modification where an existing IP-CAN bearer is modified, the PCEF supplies the specific event that caused the IP-CAN Session modification within the Event-Trigger AVP and the PCC rule name(s) and their status within the Charging-Rule-Report AVP. In the case where the UE initiates a resource modification request procedure, the PCEF includes the Packet-Filter-Information AVP, Packet-Filter-Operation AVP and QoS-Information AVP, if applicable.

When the UE is roaming in a Visited Access case, steps 3a ~ 3c are executed instead of step 3:

- 3a. The PCEF sends a Diameter CCR to the V-PCRF to request PCC Rules for the roaming user. The parameters listed in step 3 are applicable here.
 - 3b. The V-PCRF stores the information received in the Diameter CCR from the PCEF.
 - 3c. The V-PCRF sends a CCR command with the CC-Request-Type AVP set to 'UPDATE_REQUEST' to the H-PCRF. The V-PCRF includes the Subsession-Enforcement-Info AVP and the assigned S9 subsession identifier within Subsession-Id AVP. The Subsession-Operation AVP is set to the value 'MODIFICATION'.
 4. If the H-PCRF requires subscription-related information and does not have it, the PCRF sends a request to the SPR in order to receive the information.
 5. The SPR replies with the subscription related information containing the information about the allowed service(s) and PCC Rules information.
- NOTE: For steps 4 and 5: The details associated with the Sp reference point are not specified in this Release. The SPR's relation to existing subscriber databases is not specified in this Release.
6. If the AF requested a notification of the corresponding event, the H-PCRF sends a Diameter RAR with the Specific-Action AVP set to indicate the event that caused the request.
 7. If step 6 takes place, the AF may take the application specific procedure (e.g. for IMS refer to 3GPP TS 24.229[5]), replies with a Diameter RAA and may provide updated service information within. Additionally, the AF may terminate the Rx session as per clause 4.3.1.2.3.
 - 8-11. If all service data flows for an AF session are deleted, the AF session is terminated.
 12. The H-PCRF selects or generates PCC Rule(s) to be installed. The H-PCRF may also identify existing PCC rules that need to be modified or removed. The PCC Rules may relate to any of the matching AF sessions or may exist in the PCRF without matching to any AF session. The H-PCRF may also make a policy decision by deriving an authorized QoS and by deciding whether service data flows described in the PCC Rules are to be enabled or disabled.
 13. For the non-roaming case, and for the case when the UE is roaming in a Home-Routed scenario, the H-PCRF provisions the PCC Rules to the PCEF using CCA command. The H-PCRF also provides the selected Bearer Control Mode, if changed and applicable for the IP-CAN type. The PCRF may also provide a new list of event triggers for which the PCRF requires to be notified. The PCRF may provide QoS information within the APN-AMBR AVP and the Default-EPS-Bearer-QoS AVP.

When the UE is roaming in a Visited Access, steps 13a ~13c are executed instead of step 13:

- 13a. The H-PCRF sends a Diameter CCA to the V-PCRF including the PCC Rules to be provisioned within the Subsession-Decision AVP, along with the S9 subsession identifier as received in step 3b. within the Subsession-Id AVP. Other parameters listed in step 9 are also applicable here.
 - 13b. The V-PCRF validates the QoS parameters requested within the PCC Rules and enforces visited operator policies regarding QoS authorization requested by the H-PCRF as indicated by the roaming agreements.
- NOTE: If the V-PCRF rejects provisioned PCC rules received from the H-PCRF, the remaining steps in this call flow are not followed. Instead, the V-PCRF shall notify the H-PCRF by sending a Diameter CCR, including the Experimental-Result-Code AVP set to the value PCC_RULE_EVENT, identify the failed PCC rules as specified in 3GPP TS 29.215 [22], and additionally may provide the acceptable QoS Information for the service.
- 13c. The V-PCRF provisions PCC rules to the PCEF by using CCA command. The parameters listed in step 13a are applicable here.
 14. The PCEF installs, modifies or removes the provided PCC Rules. The PCEF also enforces the authorized QoS and enables or disables service flows according to the flow status of the corresponding PCC Rules.
 15. The PCEF may initiate IP-CAN session signalling or acknowledges any IP-CAN Session signalling for IP-CAN Session modification received in step 2.

- 16. If the PCRF requested to confirm that the resources associated to a PCC Rule have been successfully allocated, the PCEF-initiated IP-CAN session modification procedure is performed again starting from step 3.
- 17. For case 2a and 2b, the BBERF may initiate Gateway Control and QoS rules Provision procedure described in clause 4.4.3.

4.3.2.2 PCEF-initiated IP-CAN Session Modification, AF located in the VPLMN

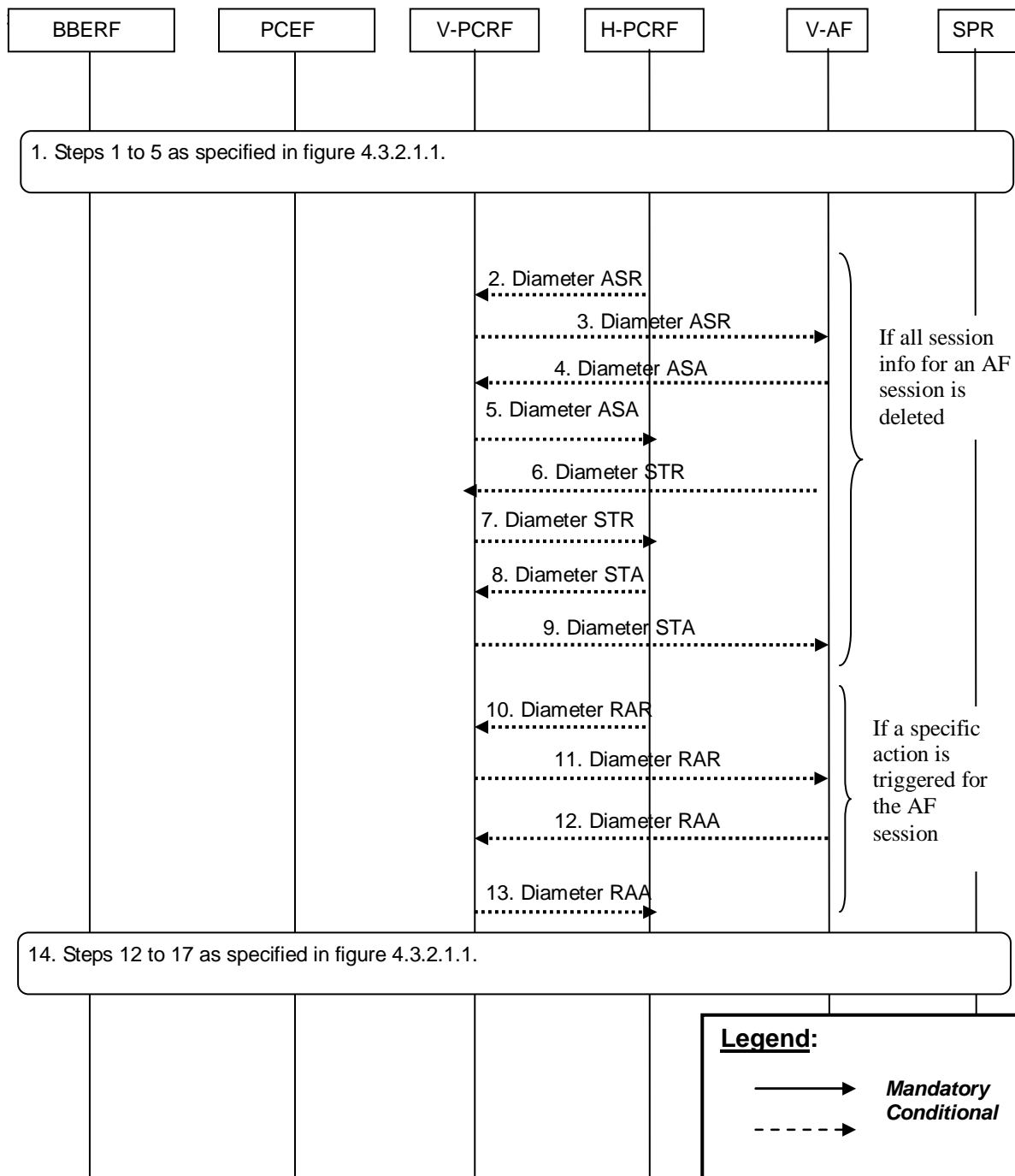

Figure 4.3.2.2.1: PCEF-initiated IP-CAN Session Modification, AF in VPLMN.

If the AF resides in the VPLMN, the V-PCRF proxies the AF session signalling over S9 between the V-AF and the H-PCRF.

- 1. Steps 1 to 5 in figure 4.3.2.1.1 are executed.

When all PCC Rules related to a particular AF session are removed, the H-PCRF initiates the AF session termination procedure. For each AF session bound to the modified IP-CAN session that is being removed, steps 2-9 are executed instead of steps 10-13:

2. The H-PCRF indicates the session abort to the V-PCRF by sending a Diameter ASR to the V-PCRF
3. The V-PCRF proxies the Diameter ASR command to the V-AF
4. The V-AF responds by sending a Diameter ASA command to the V-PCRF
5. The V-PCRF proxies the ASA command to the H-PCRF
6. The V-AF sends a Diameter STR command to the V-PCRF to indicate that the session has been terminated
7. The V-PCRF proxies the Diameter STR command to the H-PCRF
8. The V-PCRF proxies the Diameter STA command to the V-AF
9. The H-PCRF responds by sending a Diameter STA command

When the H-PCRF receives event triggers related to specific actions that the AF has subscribed to, the H-PCRF initiates the AF session modification procedure to notify the AF of these specific actions. For each AF session bound to the modified IP-CAN session that has subscribed to these specific actions, steps 10-13 are executed instead of steps 2-9:

10. If the H-PCRF is notified of an event in the access network that has to be notified to the V-AF for an AF session, the H-PCRF informs of the event by sending a RAR command to the V-PCRF.
11. The V-PCRF proxies the RAR command to the V-AF.
12. The V-AF responds by sending a RAA command to the V-PCRF
13. The V-PCRF proxies the RAA to the H-PCRF
14. Steps 12 to 17 in figure 4.3.2.1.1 are executed.

4.4 Gateway Control Session Procedures

There are two kinds of Gateway Control (GC) sessions:

- A Gateway Control session that serves a single IP-CAN session (e.g. S-GW/BBERF connecting to PDN-GW using S5/S8 PMIP according to 23.402 [22]).
- A Gateway Control session that serves all the IP-CAN sessions from the same Care-of address of the UE (e.g. a UE connecting to PDN-GW using S2c according to TS 23.402 [22]).

These Gateway Control sessions are initiated in connection with IP-CAN session establishment and Initial Attach respectively. For the first case, the PCRF will identify that the GC session serves a single IP-CAN session based on the PDN Identifier received in the request.

An access network may support mobility with BBERF change. The new BBERF shall establish new Gateway Control sessions according to the procedures defined for the new access type and the PCRF shall correlate those sessions with ongoing IP-CAN sessions as part of the handover procedure.

These scenarios are shown separately in different flows.

In the following procedures, the V-PCRF is included to depict the roaming scenarios. H-PCRF will act as a PCRF for non-roaming UEs.

4.4.1 Gateway Control Session Establishment

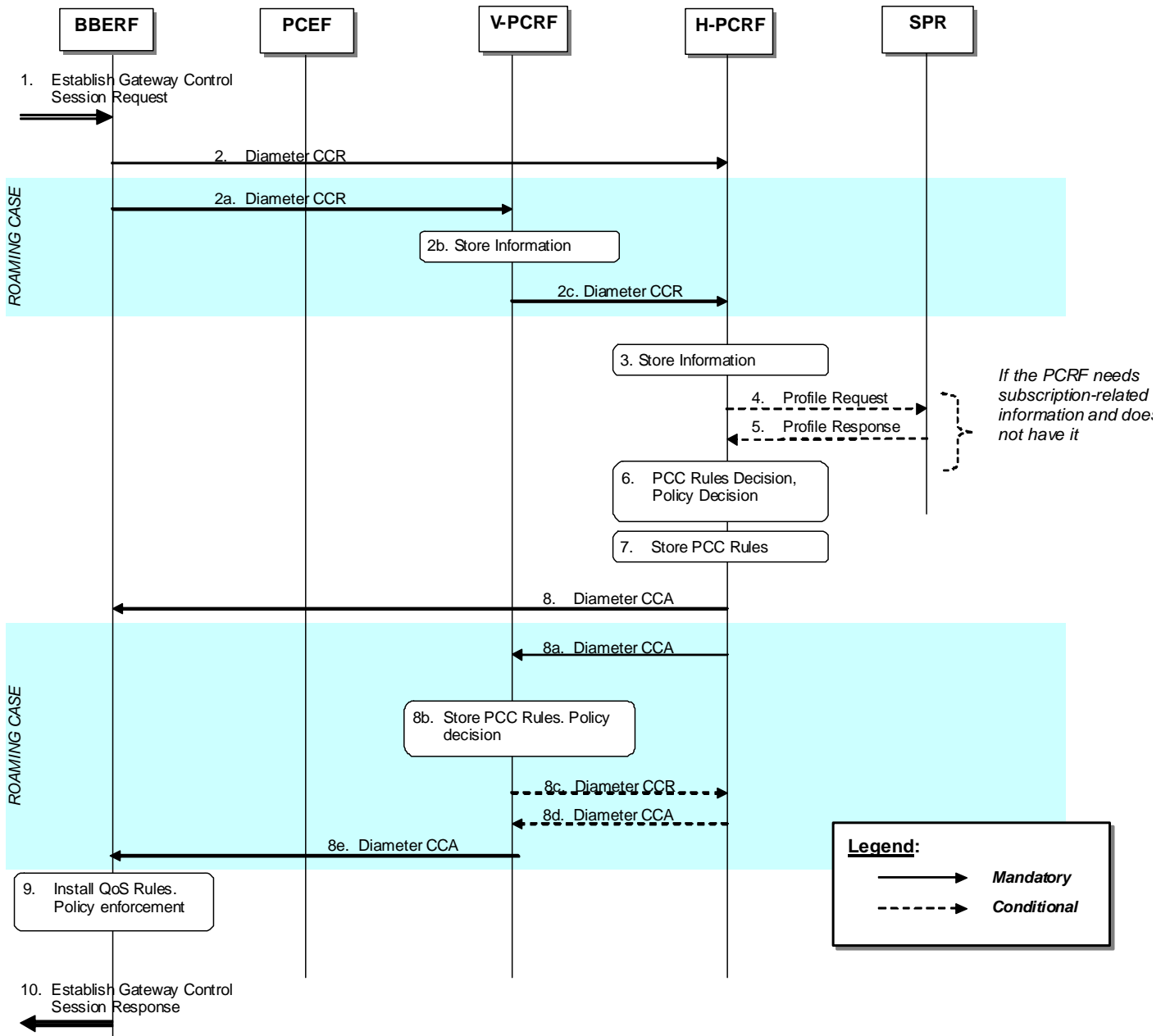

Figure 4.4.1.1: Gateway Control Session Establishment.

- The BBERF receives a message or indication that it needs to establish a Gateway Control session. For case 2a, as defined in clause 4.0, the BBERF detects that a UE has been assigned a Local IP address that the UE may use as a Care-of Address in MIP registrations (see 3GPP TS 23.402 [21], clause 6.3). For case 2b, as defined in clause 4.0, the BBERF detects that the UE requests an IP-CAN session to be established (see 3GPP TS 23.402 [21], clauses 4.5.2 and 5.6.1) or, at BBERF relocation, to be resumed with a certain APN (see 3GPP TS 23.402 [21], clauses 5.7.1 and 5.7.2) or the UE requests a pre-registration with this BBERF (see TS 23.402 [21], clause 9.3.1).
- For the non-roaming case, the BBERF initiates a Gateway Control session with the H-PCRF by sending a CCR to the H-PCRF with the CC-Request-Type AVP set to the value INITIAL_REQUEST. The BBERF provides UE identity information and the IP-CAN type. For case 2a, as defined in clause 4.0, the BBERF provides the CoA assigned to the UE. For case 2b, as defined in clause 4.0, the BBERF provides the PDN identifier and, if applicable, a Session-

Linking-Indicator to indicate if the session linking has to be deferred. The BBERF provides, when available, the APN-AMBR and Default-EPS-Bearer-QoS.

If applicable for the IP-CAN type, the BBERF additionally provides Network-Request-Support AVP to indicate whether NW-initiated procedures are supported.

When the UE is roaming, the steps 2a-2c are executed instead of step 2:

2a. The BBERF initiates a Gateway Control session with the V-PCRF by sending a CCR to the V-PCRF with the CC-Request-Type AVP set to the value INITIAL_REQUEST. The BBERF provides UE identity information and the IP-CAN type.

For case 2a, as defined in clause 4.0, the BBERF provides the CoA assigned to the UE.

For case 2b, as defined in clause 4.0, the BBERF provides the PDN identifier and, if applicable, a Session-Linking-Indicator AVP to indicate if the session linking has to be deferred. The BBERF provides, when available, the APN-AMBR and Default-EPS-Bearer-QoS.

If applicable for the IP-CAN type, the BBERF additionally provides Network-Request-Support AVP to indicate whether NW-initiated procedures are supported.

2b. The V-PCRF determines based on the UE identity information that the request is for a roaming user. The V-PCRF checks whether the V-PCRF needs to send the CCR to the H-PCRF based on the roaming agreements. For the Visited Access case, the V-PCRF does not send the CCR to the H-PCRF if the Session-Linking-Indicator AVP was received indicating that the session linking has to be deferred.

NOTE: If the V-PCRF does not send the CCR to the H-PCRF, the PCRF may generate QoS rules based on VPLMN roaming agreements.

2c. For case 2a:

- If there is not an already established S9 session for this roaming user, the V-PCRF sends a CCR to the H-PCRF with the CC-Request-Type AVP set to the value INITIAL_REQUEST. The V-PCRF includes in the CCR the information received in step 2a.
- If there is an already established S9 session for this roaming user, the V-PCRF sends a CCR to the H-PCRF with the CC-Request-Type AVP set to the value UPDATE_REQUEST. The V-PCRF includes in the CCR the information received in step 2a.

For case 2b and for the visited case or for the home routed case and if the Session-Linking-Indicator AVP is not received or it indicates SESSION_LINKING_IMMEDIATE, the following procedures apply:

- If there is not an already established S9 session for this roaming user, the V-PCRF sends a CCR to the H-PCRF with the CC-Request-Type AVP set to the value INITIAL_REQUEST. The V-PCRF includes the Subsession-Enforcement-Info AVP within the CCR with a new S9 subsession identifier assigned by the V-PCRF to this Gateway Control Session within the Subsession-Id AVP, and the Subsession-Operation AVP set to the value ESTABLISHMENT.
- If there is an already established S9 session for this roaming user and not an already established S9 subsession for the PDN connection corresponding to the Gateway Control Session, the V-PCRF sends a CCR to the H-PCRF with the CC-Request-Type AVP set to the value UPDATE_REQUEST. The V-PCRF includes the Subsession-Enforcement-Info AVP within the CCR with a new S9 subsession identifier assigned by the V-PCRF to this Gateway Control Session within the Subsession-Id AVP, and the Subsession-Operation AVP set to the value ESTABLISHMENT.
- If there is an already established S9 session for this roaming user and an already established S9 subsession for the PDN connection corresponding to the Gateway Control Session, the V-PCRF sends a CCR to the H-PCRF with the CC-Request-Type AVP set to the value UPDATE_REQUEST. The V-PCRF includes the Subsession-Enforcement-Info AVP within the CCR command with the S9 subsession identifier assigned by the V-PCRF for this PDN connection within the Subsession-Id AVP, the Subsession-Operation AVP set to the value MODIFICATION, and the BBERF identity within AN-GW-Address AVP.

For case 2b and for the home routed case and if the Session-Linking-Indicator AVP was received indicating that the session linking has to be deferred, following procedure applies:

- The V-PCRF sends a CCR to the H-PCRF with the CC-Request-Type AVP set to the value UPDATE_REQUEST. The V-PCRF includes the Subsession-Enforcement-Info AVP within the CCR with a new S9 subsession identifier assigned by the V-PCRF to this Gateway Control Session within the Subsession-Id AVP, the Subsession-Operation AVP set to the value ESTABLISHMENT and the Session-Linking-Indicator AVP set to the value "SESSION_LINKING_DEFERRED".
3. The H-PCRF stores the information received in the CCR. The H-PCRF determines the network scenario that applies (case 2a or 2b) as described in clause 4.0.

For case 2a, the H-PCRF may correlate the UE identity information with already established Gx sessions for the same UE.

For case 2b, for non roaming case, the H-PCRF links the Gateway Control session with the already established Gx Session and acts as follows:

- if the Session-Linking-Indicator was received indicating that the session linking has to be deferred, defers the session linking till the associated IP-CAN session establishment or modification is received.
 - if the Session-Linking-Indicator was not received or indicates that the session linking has to be performed immediately, links the Gateway Control session with the already established Gx Session.
4. If the H-PCRF requires subscription-related information and does not have it, the H-PCRF sends a request to the SPR in order to receive the information.
5. The SPR replies with the subscription related information containing the information about the allowed service(s), QoS information and PCC Rules information.

NOTE: For steps 4 and 5: The details associated with the Sp reference point are not specified in this Release. The SPR's relation to existing subscriber databases is not specified in this Release.

6. For case 2a, the H-PCRF may prepare for the installation of QoS rules if available;

For case 2b, the H-PCRF may

- At IP-CAN session establishment, if the session linking was not deferred, select or generate and store PCC Rule(s) in preparation for the anticipated Gx session and derive the QoS rules from them. If the session linking was deferred, the PCC rules are not generated;
 - At BBERF relocation and at pre-registration, if the Session-Linking-Indicator was not received or indicates that the session linking has to be performed immediately, prepare for the installation of QoS rules, derived from the active PCC rules, at the target BBERF;
7. The H-PCRF stores the selected QoS Rules and PCC Rules. If applicable the H-PCRF selects the Bearer Control Mode that will apply during the Gateway Control session.
8. For the non-roaming case, the H-PCRF acknowledges the Gateway Control Session by sending a CCA to the BBERF. The H-PCRF includes
- The selected BCM, if applicable for the IP-CAN type
 - If NW-initiated procedures are available, the available QoS rules
 - If BCM is UE-only, the QoS rules that correspond to the request from the BBERF
 - Default-EPS-Bearer-QoS and APN-AMBR when applicable
 - The event triggers

When the UE is roaming, the steps 8a-8e are executed instead of step 8:

- 8a. The H-PCRF acknowledges the Gateway Control Session by sending a CCA to the V-PCRF. The H-PCRF includes
- The selected BCM, if applicable for the IP-CAN type
 - If NW-initiated procedures are available, the available QoS rules for the home routed case or the available PCC rules for the visited access case

- If BCM is UE-only, the QoS rules that correspond to the request from the V-PCRF for the home routed case or the PCC rules that correspond to the request from the V-PCRF for the visited access case
 - For the case 2a, the QoS rules when the available QoS rule are not related to any IP-CAN session
 - Default-EPS-Bearer-QoS and APN-AMBR when applicable
 - Event triggers
- 8b. The V-PCRF enforces visited operator policies regarding QoS authorization requested by the H-PCRF as indicated by the roaming agreements.
- 8c. If the V-PCRF denies an authorization, it informs the H-PCRF and may provide the acceptable QoS Information for the service.
- 8d. The H-PCRF may provide new or modified PCC/QoS rules to the V-PCRF
- 8e. If V-PCRF receives the PCC rules from the H-PCRF, the V-PCRF extracts the QoS rules from the PCC rules. The V-PCRF acknowledges the Gateway Control Session establishment by sending a CCA to the BBERF. The V-PCRF includes the selected BCM if applicable for the IP-CAN type, any applicable QoS rules and event triggers.
9. The BBERF installs and enforces the received QoS Rules.
10. The BBERF sends an Establish Gateway Session Control Response to ack the Gateway Control Session Request.

4.4.2 Gateway Control and QoS Rules Request

4.4.2.1 Non-Roaming and Home Routed cases

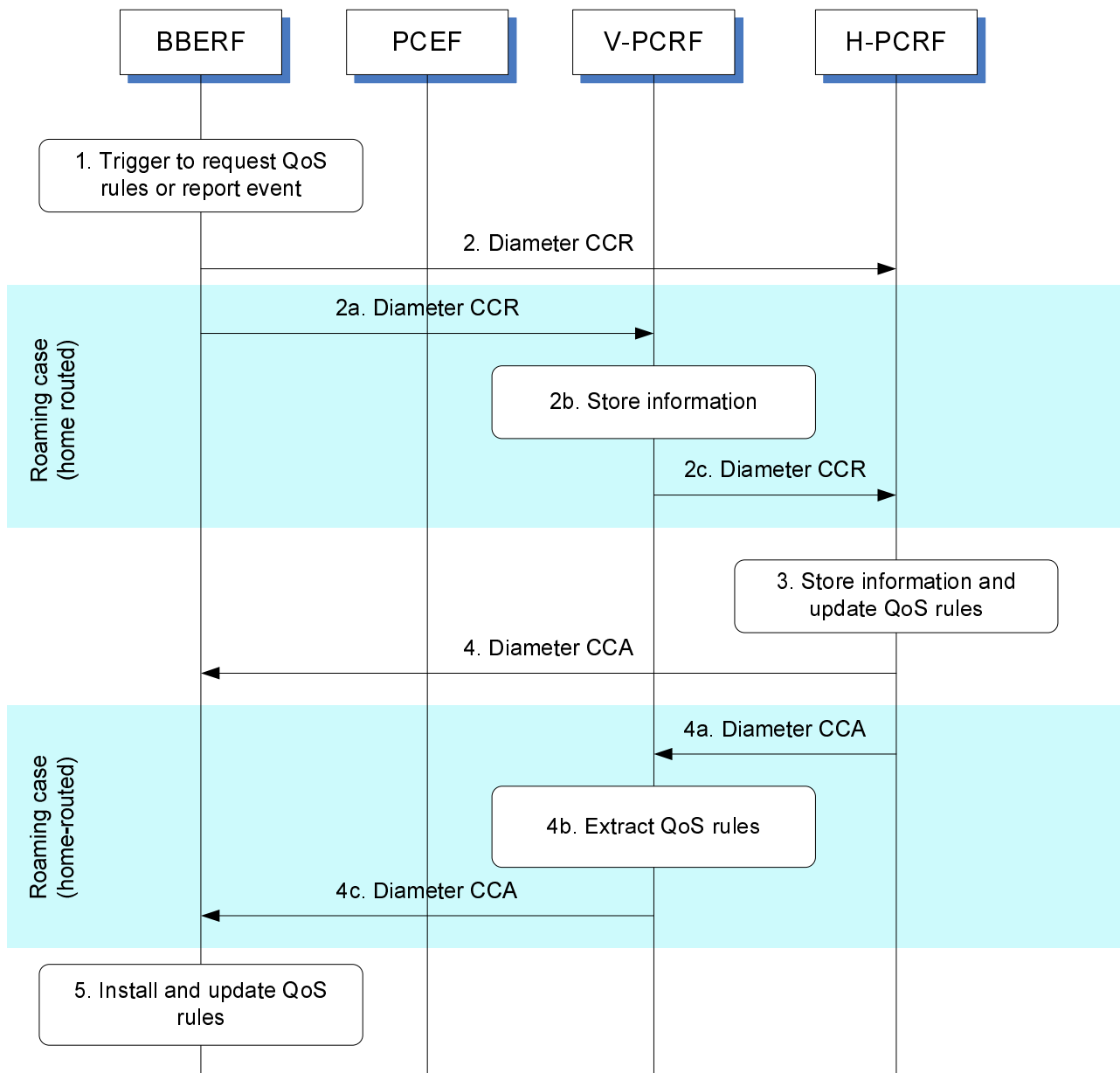

Figure 4.4.2.1.1: Gateway Control and QoS Rules Request for non-roaming and home routed

1. The BBERF is triggered to either report an event or obtain QoS rules or both for a gateway control session.
2. The BBERF sends a Diameter CCR to the H-PCRF with the CC-Request-Type AVP set to the value UPDATE_REQUEST to report event or request QoS rules.

When the UE is roaming (home-routed traffic), steps 2a ~ 2c are executed instead of step 2:

- 2a. The BBERF sends a Diameter CCR to the V-PCRF with the CC-Request-Type AVP set to the value UPDATE_REQUEST to report event or request QoS rules.
- 2b. The V-PCRF stores the information received.
- 2c. For case 2a, The V-PCRF sends a Diameter CCR to the H-PCRF within the information received in step 2a at command level.

For case 2b, The V-PCRF sends a Diameter CCR to the H-PCRF within the information received in step 2a at Subsession-Enforcement-Info AVP

3. The H-PCRF stores the received information in the Diameter CCR and derives updated QoS rules and event triggers.
4. The H-PCRF provisions the updated QoS rules and event triggers to the BBERF using Diameter CCA. The CCA may also only acknowledge that the event report has been received successfully.

When the UE is roaming (home-routed traffic), steps 4a ~ 4c are executed instead of step 4:

- 4a. The H-PCRF sends the updated QoS rules and event triggers to the V-PCRF using Diameter CCA. The CCA may also only acknowledge that the event report has been received successfully.
- 4b. The V-PCRF may also perform further authorization of the rules based on local policies.
- 4c. The V-PCRF sends the updated QoS rules and event triggers to the BBERF using Diameter CCA.
5. The BBERF installs the received QoS Rules and event triggers. This may result in bearer binding being performed according to the rules. The BBERF also enables or disables service flow according to the flow status of the corresponding QoS Rules. The result of the QoS rule activation may trigger the BBERF to send an additional Diameter CCR as described above to the PCRF, for example, to indicate that QoS rule activation has failed.

4.4.2.2 Visited access cases

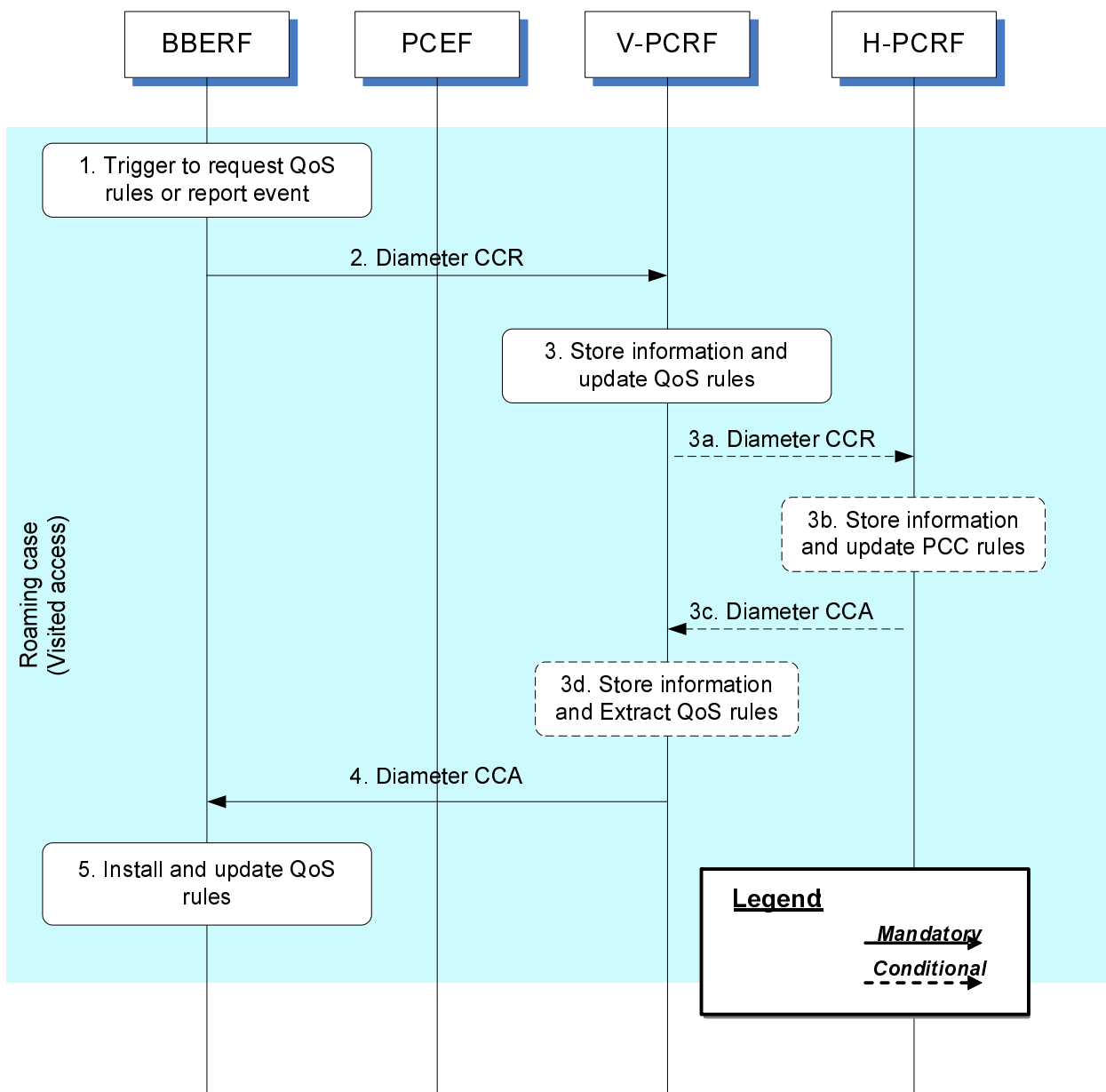

Figure 4.4.2.2.1: Gateway Control and QoS Rules Request for visited access

1. The BBERF is triggered to either report an event or obtain QoS rules or both for a gateway control session.
2. The BBERF sends a Diameter CCR to the V-PCRF with the CC-Request-Type AVP set to the value UPDATE_REQUEST to report event or request QoS rules.
3. The V-PCRF stores the information received in the Diameter CCR and derives updated QoS rules and event triggers according to local policies and roaming agreements.

When the report event is subscribed by H-PCRF, the steps 3a~3d are executed instead of step3:

- 3a. The V-PCRF sends a Diameter CCR to the H-PCRF with the CC-Request-Type AVP set to the value UPDATE_REQUEST to report event.

For case 2a, the information received in step 2 is send to H-PCRF at command level.

For case 2b, the CCR is send with the information provided at subsession level within the Subsession-Enforcement-Info AVP.

- 3b. The H-PCRF stores the received information in the Diameter CCR and derives event triggers.
- 3c. The H-PCRF sends the event triggers to the V-PCRF using Diameter CCA. The CCA may also only acknowledge that the event report has been received successfully.
- 3d. The V-PCRF may also perform further authorization of the rules based on local policies.
- 4. The V-PCRF provisions the updated QoS rules and event triggers to the BBERF using Diameter CCA.
- 5. The BBERF installs the received QoS Rules and event triggers. This may result in bearer binding being performed according to the rules. The BBERF also enables or disables service flow according to the flow status of the corresponding QoS Rules. The result of the QoS rule activation may trigger the BBERF to send an additional Diameter CCR as described above to the PCRF, for example, to indicate that QoS rule activation has failed.

4.4.3 Gateway Control and QoS Rules Provision

Since the PCRF is required to keep QoS rules aligned with the active PCC rules for a certain IP-CAN session, it shall initiate the Gateway Control and QoS Rules Provision whenever there is a change to the corresponding PCC rules for a Gx session that is linked with the Gateway Control Session.

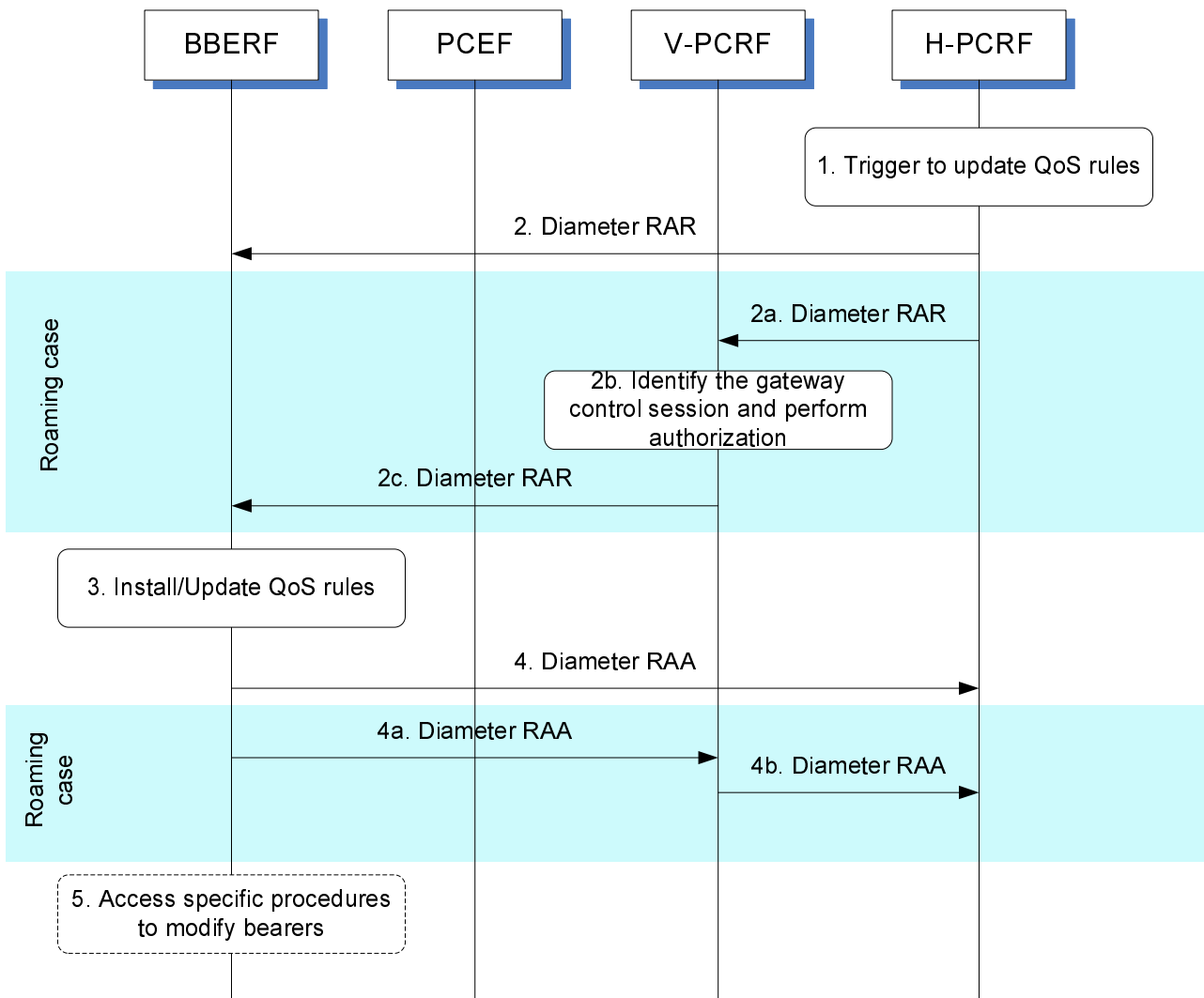

Figure 4.4.3.1: Gateway Control and QoS Rules Provision

- 1. The H-PCRF receives an internal or external trigger to update QoS Rules and event triggers for a gateway control session.

2. The H-PCRF sends a Diameter RAR to request that the BBERF installs, modifies or removes QoS Rules and/or updates the event triggers.

If the UE is roaming, then steps 2a ~ 2c are executed instead of step 2:

- 2a. The H-PCRF sends a Diameter RAR to the V-PCRF to provision updated QoS Rules and updated event triggers.

For case 2a, the RAR provides the updated QoS Rules and updated event triggers with the information included at command level.

For case 2b, The H-PCRF sends a Diameter RAR to the V-PCRF within the information at Subsession-Decision-Info AVP.

- 2b. The V-PCRF identifies the gateway control session if needed and performs local authorization of the updated QoS rules when necessary.
- 2c. The V-PCRF sends a Diameter RAR to the BBERF to provision updated QoS rules and updated event triggers.
3. The BBERF installs, modifies or removes the identified QoS Rules. The BBERF also enforces the authorized QoS and enables or disables service flow according to the flow status of the corresponding QoS Rules.
4. The BBERF sends RAA to the H-PCRF to acknowledge the RAR and informs the H-PCRF about the outcome of the QoS rule operation. If network initiated resource allocation procedures apply for the QoS rules and the corresponding IP-CAN bearer can not be established or modified to satisfy the bearer binding, then the BBERF rejects the activation of a PCC rule.

If the UE is roaming, then steps 4a ~ 4b are executed instead of step 4:

- 4a. The BBERF sends RAA to the V-PCRF to acknowledge the RAR and informs the V-PCRF about the outcome of the QoS rule operation. If network initiated resource allocation procedures apply for the QoS rules and the corresponding IP-CAN bearer can not be established or modified to satisfy the bearer binding, then the BBERF rejects the activation of a PCC rule.
- 4b. The V-PCRF forwards the RAA to the H-PCRF to acknowledge the RAR and informs the H-PCRF about the outcome of the QoS rule operation.
5. If needed, the BBERF initiates the access specific procedures to create or modify existing IP-CAN bearers. When the procedure in step 5 is completed and requires of notifications from the BBERF to the PCRF, the steps described as in clause 4.4.2 are additionally executed.

4.4.4 Gateway Control Session Termination

4.4.4.1 BBERF-Initiated Gateway Control Session Termination

This procedure applies for case 2b, as defined in clause 4.0, whenever the BBERF detects a request for a PDN disconnection, mobility to other access or the termination of a pre-registration at the BBERF.

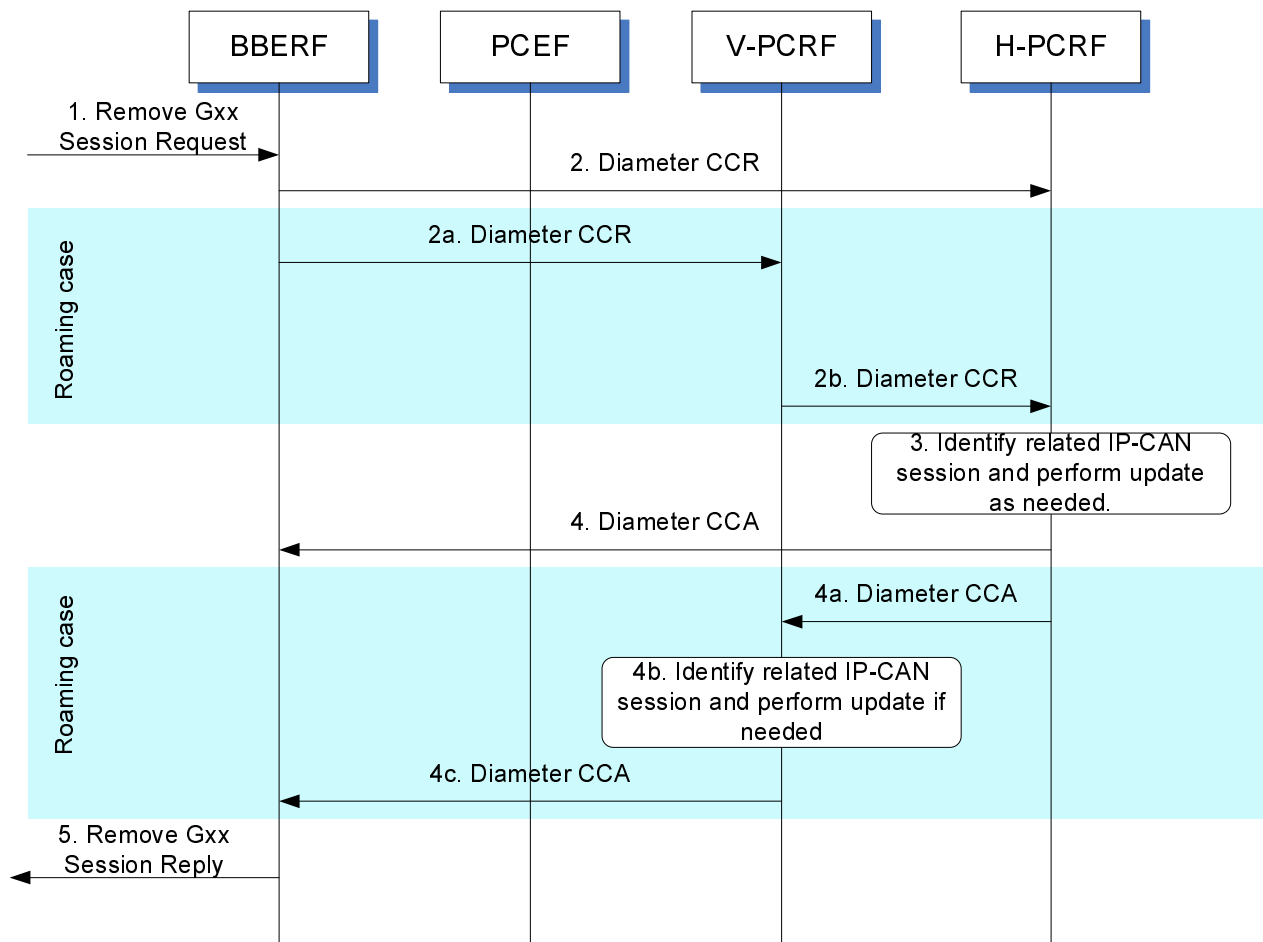

Figure 4.4.4.1.1: BBERF-Initiated Gateway Control Session Termination

1. The BBERF is requested to terminate its gateway control session. The form of the request to remove the gateway control session depends upon the type of the IP-CAN.
2. The BBERF sends a Diameter CCR message to the H-PCRF, indicating the gateway control session termination. The BBERF requests the termination of the DCC session using the CC-Request-Type AVP set to the value TERMINATION_REQUEST.

If the UE is roaming, then steps in 2a ~ 2b are executed instead of step 2:

- 2a. The BBERF sends a Diameter CCR message to the V-PCRF, indicating the gateway control session termination. The BBERF requests the termination of the DCC session using the CC-Request-Type AVP set to the value TERMINATION_REQUEST.
- 2b. For the case 2a or if this is the last subsession associated with the S9 session for the case 2b, the V-PCRF sends a Diameter CCR message to the H-PCRF to request the termination of the S9 session. Otherwise, if the gateway control session is locally handled at the V-PCRF, the V-PCRF continues from step 4b; if the gateway control session has a corresponding S9 subsession, then the V-PCRF sends a Diameter CCR message to the H-PCRF to request the termination of the corresponding S9 subsession.
3. The H-PCRF identifies the related IP-CAN session and performs update as necessary.
4. The H-PCRF acknowledges the session termination by sending a Diameter CCA message.

If the UE is roaming, then steps 4a ~ 4c are executed instead of step 4:

- 4a. If the H-PCRF receives the Diameter CCR message in step 2b, the H-PCRF acknowledges the session or subsession termination request by sending a Diameter CCA message to the V-PCRF.
- 4b. The V-PCRF identifies the related IP-CAN session and performs update as necessary.

4c. The V-PCRF acknowledges the session termination by sending a Diameter CCA message to the BBERF.

- The BBERF sends a reply to the request to remove the gateway control session. The form of the reply depends upon the type of the IP-CAN.

4.4.4.2 PCRF-Initiated Gateway Control Session Termination

This procedure applies for case 2a, as defined in clause 4.0, when the PCRF detects that there is no remaining IP-CAN session at the PCRF.

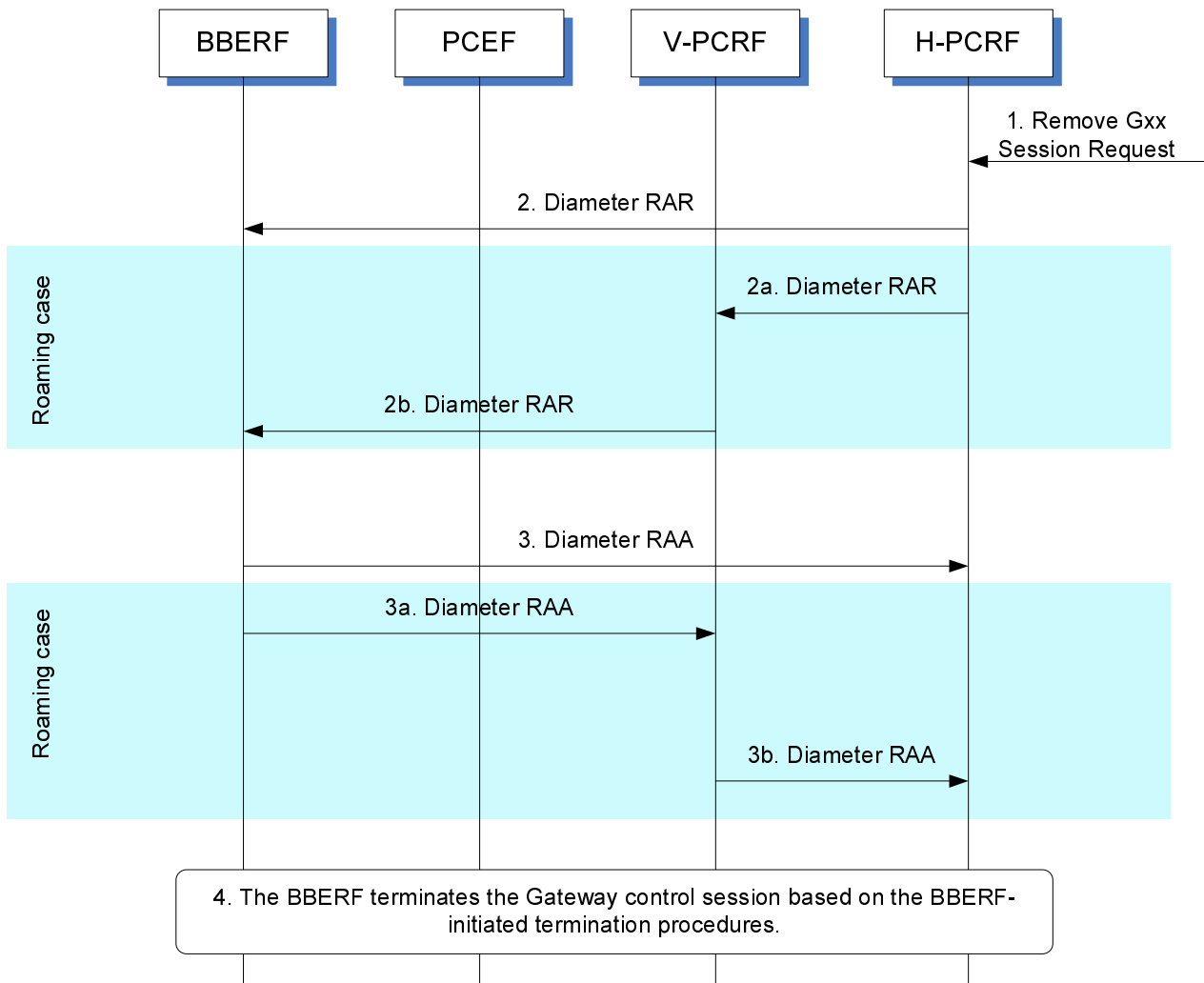

Figure 4.4.4.2.1: PCRF-Initiated Gateway Control Session Termination

- The H-PCRF is requested to terminate the gateway control session.
- The H-PCRF sends a Diameter RAR message to the BBERF including a Session-Release-Cause AVP to indicate request for terminating the gateway control session.

If the UE is roaming, then steps in 2a ~ 2b are executed instead of Step 2:

2a. The H-PCRF sends a Diameter RAR message to the V-PCRF to indicate the termination of the S9 session including the Session-Release-Cause AVP.

2b. The V-PCRF sends a Diameter RAR message to the BBERF based on the termination request received from the H-PCRF to indicate the gateway control session termination.

3. The BBERF acknowledges the gateway control session termination request by sending a Diameter RAA message.

If the UE is roaming, then steps 3a ~ 3b are executed instead of Step 3:

- 3a. The BBERF acknowledges the gateway control session termination request by sending a Diameter RAA message to the V-PCRF.
 - 3b. The V-PCRF sends a Diameter RAA message to the H-PCRF and acknowledges the request for terminating the S9 session corresponding to the gateway control session.
4. The BBERF follows the BBERF-initiated gateway control session termination procedures described in clause 4.4.4.1 to terminate the gateway control session.

4.5 Multiple BBERF Signalling Flows

4.5.1 Non-Roaming and Home Routed cases

4.5.1.1 New Gateway Control Session Establishment

The following signalling flow describes an example of a new BBERF initiating a GW control session establishment associated with an existing IP-CAN session.

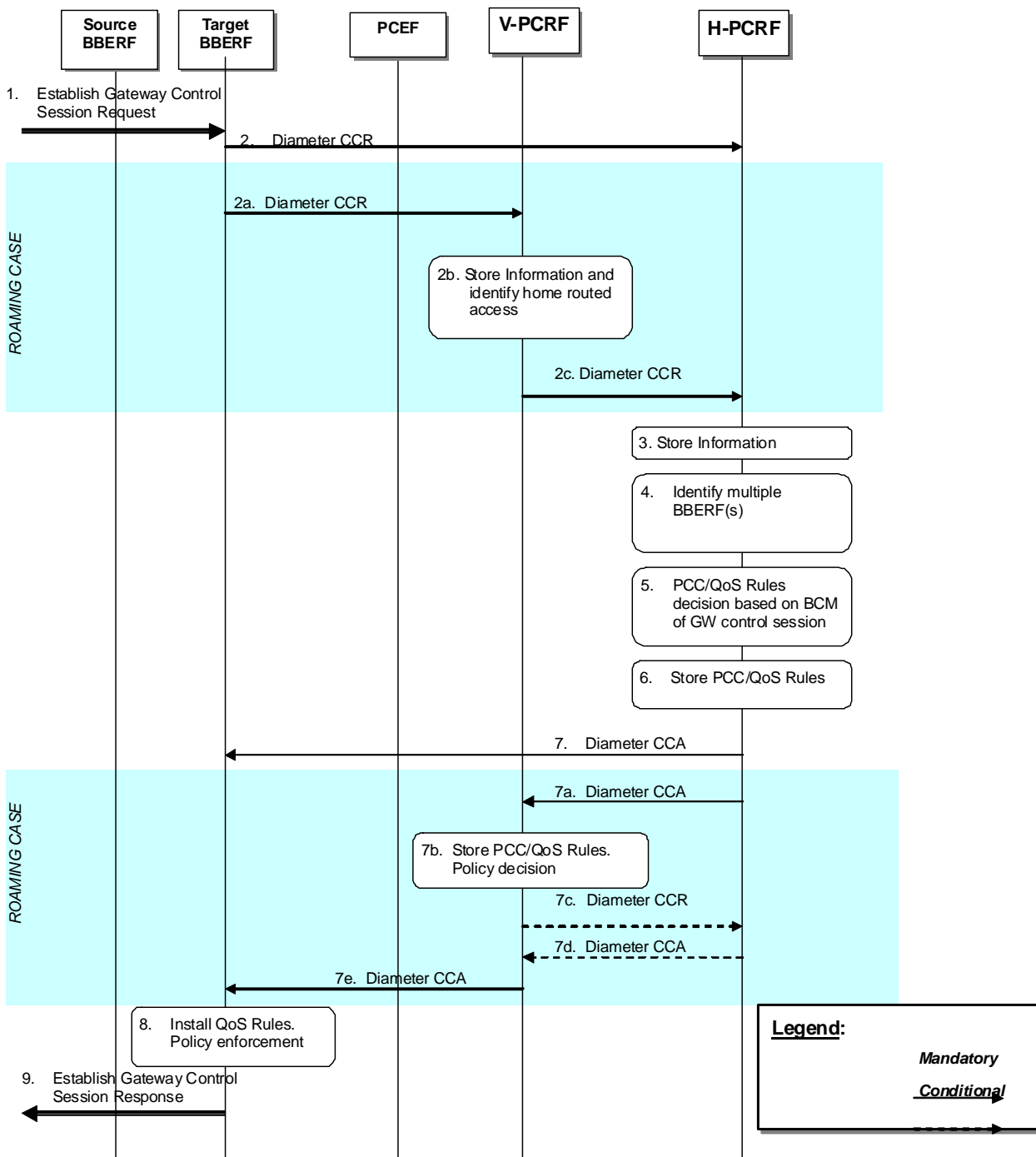

Figure 4.5.1.1.1: Gateway Control Session Establishment during BBERF relocation.

1. The target BBERF receives a message or indication to establish a Gateway Control session
2. The target BBERF initiates a Gateway Control session with the H-PCRF by sending a CCR using the CC-Request-Type AVP set to the value INITIAL_REQUEST to the H-PCRF. The target BBERF provides information as detailed in clause 4a.5.1 of 3GPP TS 29.212 [9]

When the UE is roaming, the following steps are executed instead of step 2:

- 2a. The target BBERF initiates a Gateway Control session with the V-PCRF by sending a CCR using the CC-Request-Type AVP set to the value INITIAL_REQUEST to the V-PCRF. The target BBERF provides information as detailed in clause 4a.5.1 of 3GPP TS 29.212 [9].

2b. The V-PCRF determines based on the UE identity information that the request is for a roaming user. The V-PCRF checks whether the V-PCRF is required to send the request to the H-PCRF based on the roaming agreements.

2c. For case 2a:

- The V-PCRF sends a CCR to the H-PCRF with the CC-Request-Type AVP set to the value UPDATE_REQUEST. The V-PCRF includes in the CCR the information received in step 2a. The V-PCRF includes the BBERF identity by including the AN-GW-Address AVP at command level.

For case 2b:

- If the Session-Linking-Indicator AVP is not received, or it indicates SESSION_LINKING_IMMEDIATE, the V-PCRF sends the CCR command to the H-PCRF with the CC-Request-Type AVP set to the value UPDATE_REQUEST. The V-PCRF includes the Subsession-Enforcement-Info AVP within the CCR command with allocated S9 subsession identifier assigned by the V-PCRF for this PDN connection within the Subsession-Id AVP, the Subsession-Operation AVP set to the value MODIFICATION, the BBERF identity within AN-GW-Address AVP.
- If the Session-Linking-Indicator AVP is received indicating that the session linking has to be deferred, the V-PCRF sends a CCR to the H-PCRF with the CC-Request-Type AVP set to the value UPDATE_REQUEST. The V-PCRF includes the Subsession-Enforcement-Info AVP within the CCR with a new S9 subsession identifier assigned by the V-PCRF to this Gateway Control Session within the Subsession-Id AVP, the Subsession-Operation AVP set to the value ESTABLISHMENT and the Session-Linking-Indicator AVP set to the value "SESSION_LINKING_DEFERRED".

3. The H-PCRF stores the information received in the Diameter CCR.
4. If the Session-Linking-Indicator AVP was received indicating that the session linking has to be deferred, the linking between the Gateway Control Session and the Gx session shall be deferred. Otherwise, based on the information received the H-PCRF identifies multiple BBERF sessions for a particular IP-CAN session.
5. The H-PCRF derives applicable PCC/QoS rules based on the BCM mode as defined in clause 4a.5.7 of 3GPP TS 29.212 [9]
6. The H-PCRF stores the selected QoS Rules and PCC Rules. For non-roaming users the H-PCRF selects the Bearer Control Mode that will apply during the Gateway Control session.
7. The H-PCRF acknowledges the Gateway Control Session by sending a Diameter CCA. The H-PCRF includes the selected BCM if applicable, the QoS rules and event triggers.

When the UE is roaming, the following steps are executed instead of step 7:

- 7a. The H-PCRF acknowledges the Gateway Control Session by sending a Diameter CCA to the V-PCRF. The H-PCRF includes applicable QoS rules and also event triggers. The H-PCRF also includes the AN-GW-Address AVP if the QoS rules are applicable for a single BBERF.
 - 7b. The V-PCRF enforces visited operator policies regarding QoS authorization requested by the H-PCRF as indicated by the roaming agreements.
 - 7c. If the V-PCRF denies an authorization, it informs the H-PCRF and may provide the acceptable QoS Information for the service.
 - 7d. The H-PCRF may provide new or modified QoS rules to the V-PCRF
 - 7e. The V-PCRF acknowledges the Gateway Control Session and provisions, when applicable, the selected BCM, policy decisions and event triggers to the target BBERF.
8. The BBERF installs the received QoS Rules.
 9. The target BBERF establishes an indication for a Gateway control session response

4.5.1.2 PCEF IP-CAN session modification - Handover

The following signalling flow describe the case when an indication of handover is received by the PCEF and the H-PCRF derives QoS rules based on the type of BBERF (primary/non-primary)

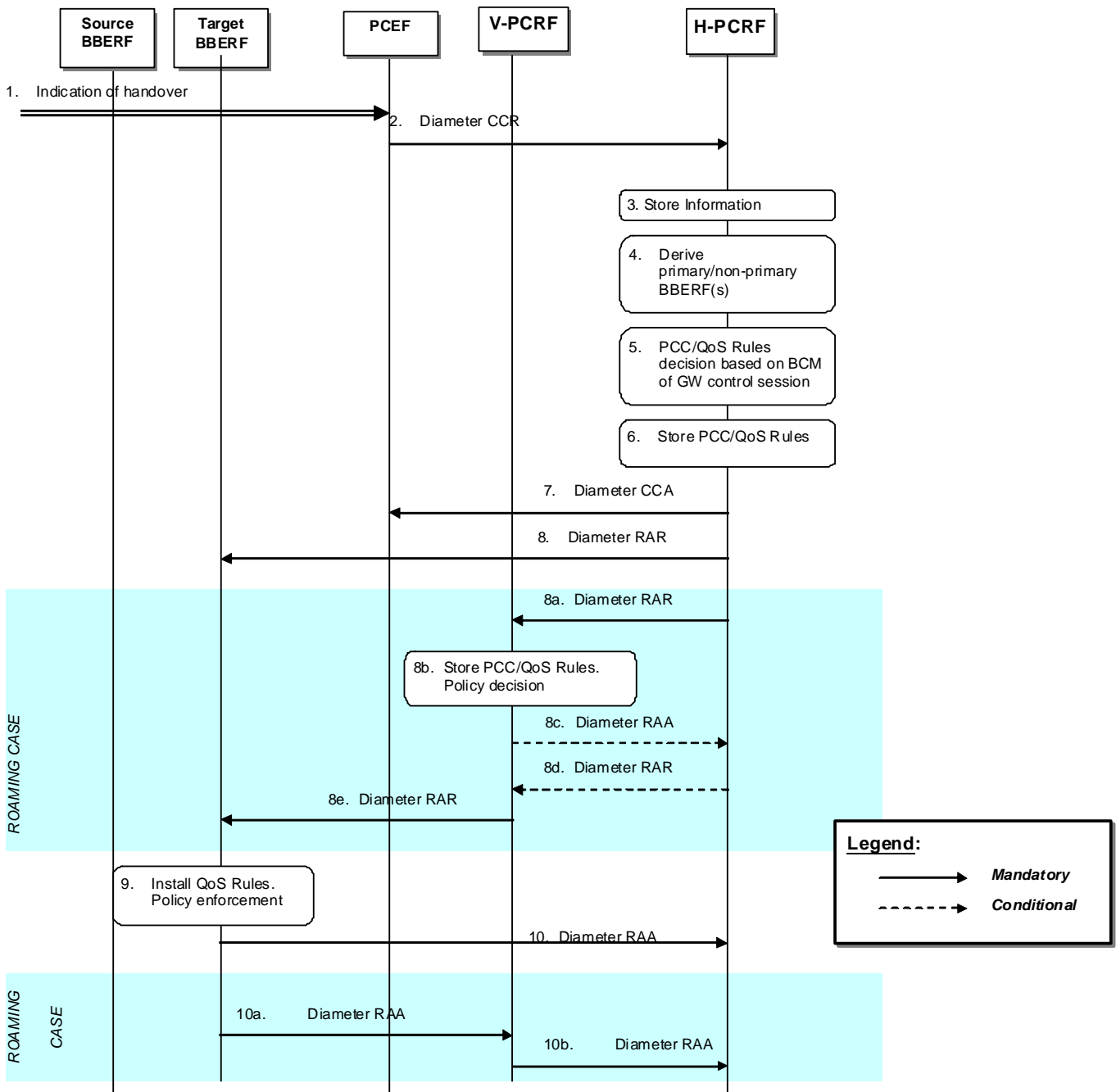

Figure 4.5.1.2.1: PCEF IP-CAN session modification - Handover.

1. The PCEF receives a message or indication that a handover occurred
2. The PCEF initiates an IP-CAN Session Modification procedure by sending a CCR using the CC-Request-Type AVP set to the value UPDATE_REQUEST to the H-PCRF. The PCEF includes the AN_GW_CHANGE event trigger, and if applicable the IP-CAN_CHANGE event trigger as well, to indicate that handover has occurred.
3. The H-PCRF stores the information received in the Diameter CCR.
4. If there is a pending gateway control session to be linked to a Gx session, the H-PCRF shall perform the session linking according to clause 4a.5.6 of 3GPP TS 29.212 [9] for the non-roaming case. Based on the information received the H-PCRF reclassifies primary/non-primary BBERFs according to the procedures defined in clause 4a.5.7 of 3GPP TS 29.212 [9].

5. The H-PCRF derives PCC rules for the PCEF, and QoS rules for the new reclassified primary BBERF, based on the BCM mode of the GW control session as defined in clause 4a.5.7 of 3GPP TS 29.212 [9]
6. The H-PCRF stores the selected QoS Rules and PCC Rules.
7. The H-PCRF acknowledges the IP-CAN session modification request by sending a Diameter CCA to the PCEF. The H-PCRF includes updated PCC rules and event triggers (if applicable)
8. The H-PCRF initiates a Gateway Control and QoS Rules Provision procedure by sending a Diameter RAR. The H-PCRF includes the selected BCM if applicable, the QoS rules and event triggers.

When the UE is roaming, the following steps are executed instead of step 8:

- 8a. The H-PCRF initiates a Gateway Control and QoS Rules Provision procedure to the V-PCRF by sending a Diameter RAR to the V-PCRF. The H-PCRF sends applicable QoS rules based on the BBERF type (primary/non-primary) and BCM mode selected as defined in clause 4a.5.9 of 3GPP TS 29.212[9]. The H-PCRF includes the AN-GW-Address AVP if the QoS rules are applicable only for a single BBERF. If the QoS rules are applicable for all BBERF sessions this AVP is omitted.
 - 8b. The V-PCRF enforces visited operator policies regarding QoS authorization requested by the H-PCRF as indicated by the roaming agreements.
 - 8c. If the V-PCRF denies an authorization, it informs the H-PCRF and may provide the acceptable QoS Information for the service by including in the RAA command the QoS-Rule-Report AVP to indicate the QoS Rules that were not accepted, the Rule-Failure-Code AVP set to UNSUCCESSFUL-QoS-VALIDATION, and the QoS-Information AVP.
 - 8d. The H-PCRF may provide new or modified QoS rules to the V-PCRF
 - 8e. The V-PCRF initiates the Gateway Control Session and QoS rules provisions, when applicable, the selected BCM, policy decisions and event triggers to the target BBERF.
9. The BBERF installs the received QoS Rules.
 10. The target BBERF acknowledges the RAR command by sending a Diameter RAA command to the PCRF

When the UE is roaming, the following steps are executed instead of step 10:

- 10a. The BBERF acknowledges the Gateway Control and QoS Rules Provision request by sending a Diameter RAA to the V-PCRF
- 10b. The V-PCRF acknowledges the Gateway Control and QoS Rules Provision request by sending a Diameter RAA to the H-PCRF

4.5.2 Visited access case

4.5.2.1 New Gateway Control Session Establishment

The following signalling flow describes an example of a new BBERF initiating a GW control session establishment associated with an existing IP-CAN session.

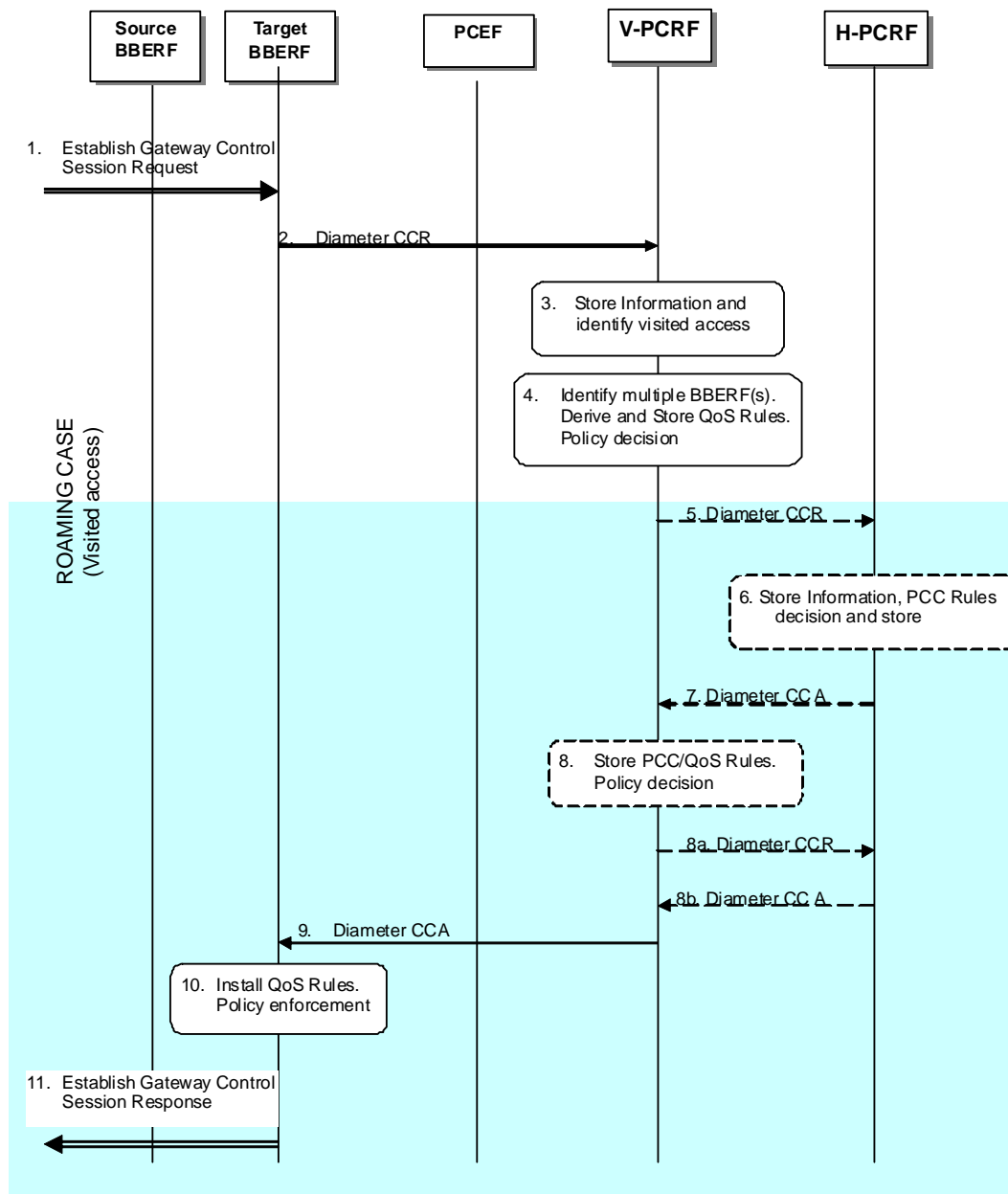

Figure 4.5.2.1.1: Gateway Control Session Establishment during BBERF relocation.

1. The target BBERF receives a message or indication to establish a Gateway Control Session.
2. The target BBERF initiates a Gateway Control Session with the V-PCRF by sending a CCR using the CC-Request-Type AVP set to the value INITIAL_REQUEST to the V-PCRF. The target BBERF provides information as detailed in clause 4a.5.1 of 3GPP TS 29.212 [9].
3. The V-PCRF stores the information received in the Diameter CCR and determines based on the UE identity information that the request is for a roaming user. The V-PCRF checks whether the V-PCRF is required to send the request to the H-PCRF based on the roaming agreement. The V-PCRF does not send the CCR to the H-PCRF to update the S9 session immediately if the Session-Linking-Indicator AVP was received indicating that the session linking has to be deferred.
4. If the Session-Linking-Indicator AVP was received indicating that the session linking has to be deferred, the linking between the Gateway Control Session and the Gx session shall be deferred. Otherwise, based on the information received the V-PCRF identifies multiple BBERF sessions for a particular IP-CAN session. The V-PCRF derives applicable QoS rules according to local policies and stores them.

For case 2a or if either the AN_GW_CHANGE or the IP_CAN_CHANGE event is subscribed by H-PCRF and this event trigger is received steps 5~8 are executed. Otherwise steps 5~8 are skipped.

5. The V-PCRF initiates an IP-CAN Session Modification procedure by sending a CCR to the H-PCRF with the CC-Request-Type AVP set to the value UPDATE_REQUEST. The V-PCRF includes in the CCR the information received in step 2.
6. The H-PCRF stores the information received in the Diameter CCR. And the H-PCRF decides PCC rules for the BBERF and stores PCC rules.
7. The H-PCRF sends a Diameter CCA to the V-PCRF to provide the PCC rules. The H-PCRF sends applicable PCC rules. The H-PCRF includes the AN-GW-Address AVP if the PCC rules are applicable only for a single BBERF. If the PCC rules are applicable for all BBERF sessions this AVP is omitted.
8. If the steps 5~7 are executed, the V-PCRF enforces visited operator policies regarding QoS authorization requested by the H-PCRF as indicated by the roaming agreements.

Steps 8a and 8b are executed if the V-PCRF denies authorisation for one or more PCC rules.

8a. If V-PCRF denies authorization, it informs the H-PCRF by sending a CCR command including the Charging-Rule-Report AVP to indicate the PCC Rules that were not accepted, the Rule-Failure-Code AVP set to UNSUCCESSFUL-QoS-VALIDATION, and the acceptable QoS Information for the service.

8b. The H-PCRF may provide new modified PCC rules to the V-PCRF.

9. The V-PCRF acknowledges the Gateway Control Session and provisions policy decisions and event triggers to the target BBERF.
10. The BBERF installs the received QoS rules.
11. The target BBERF responds to the Gateway control session establishment request in step 1.

4.5.2.2 PCEF-Initiated IP-CAN session modification-Handover

The following signalling flow describe the case when an indication of handover is received by the PCEF and the H-PCRF derives QoS rules based on the type of BBERF (primary/non-primary)

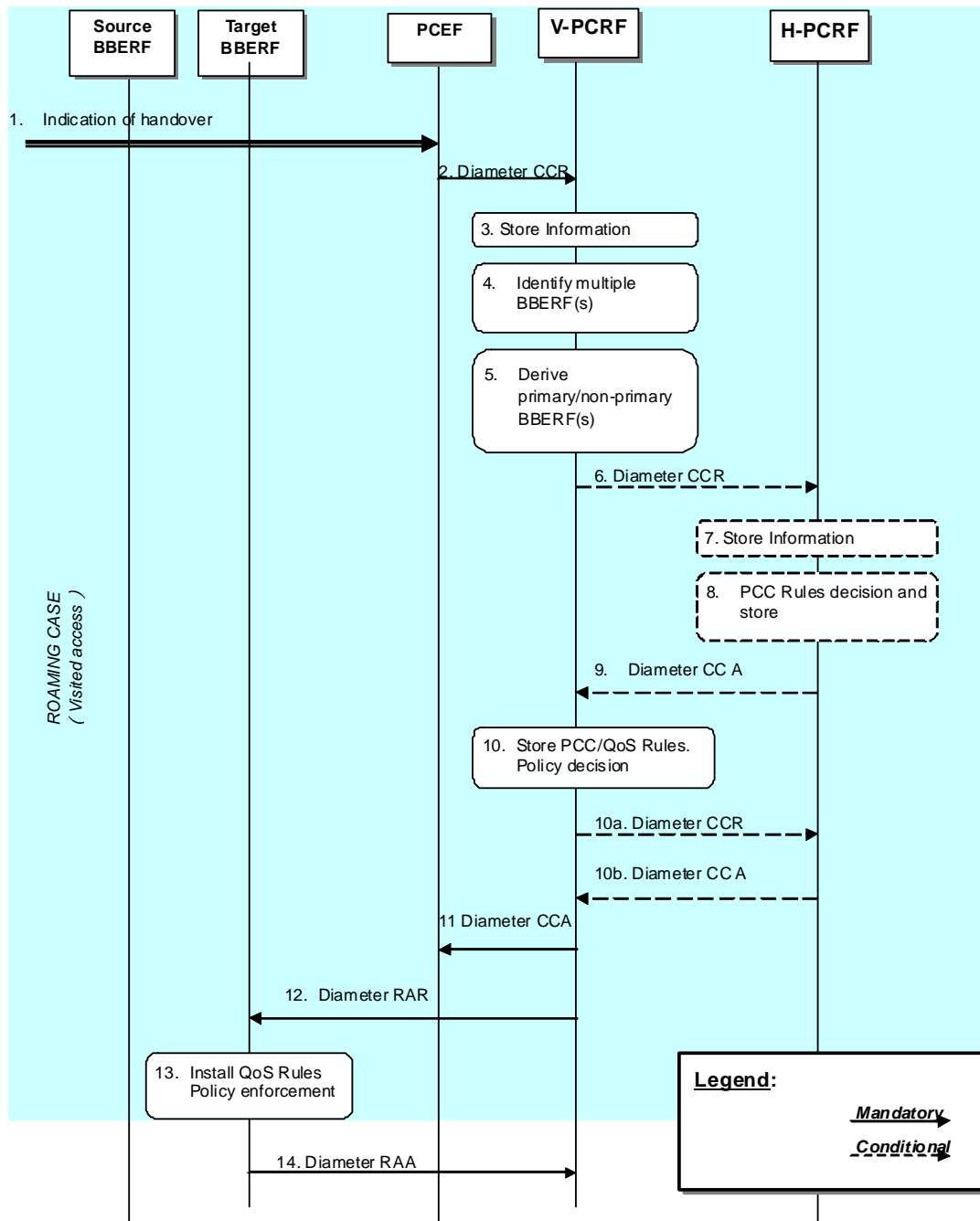

Figure 4.5.2.2.1: PCEF-initiated IP-CAN session modification - Handover.

1. The PCEF receives a message or indication that a handover occurred.
2. The PCEF initiates an IP-CAN Session Modification procedure by sending a CCR using the CC-Request-Type AVP set to the value UPDATE_REQUEST to the V-PCRF. The PCEF includes the AN_GW_CHANGE event trigger, and if applicable the IP-CAN_CHANGE event trigger as well, to indicate that handover has occurred.
3. The V-PCRF stores the information received in the Diameter CCR.
4. If there is a pending Gateway Control Session to be linked to a Gx session, the V-PCRF links the Gateway Control Session with the Gx session according to clause 4a.5.6 of 3GPP TS 29.212 [9]. Otherwise, based on the information received the V-PCRF identifies multiple BBERF sessions for a particular IP-CAN session.
5. Based on the information received the V-PCRF reclassifies primary/non-primary BBERFs according to the procedures defined in clause 4a.5.7 of 3GPP TS 29.212 [9].

If either the AN_GW_CHANGE or the IP-CAN_CHANGE event is subscribed by H-PCRF and this event trigger is received steps 6~9 are executed. Otherwise steps 6~9 are skipped.

6. The V-PCRF initiates an IP-CAN Session Modification procedure by sending a CCR to the H-PCRF with the CC-Request-Type AVP set to the value UPDATE_REQUEST. The V-PCRF includes in the CCR the information received in step 2.
7. The H-PCRF stores the information received in the Diameter CCR.
8. The H-PCRF decides PCC rules for the PCEF and stores PCC rules.
9. The H-PCRF sends a Diameter CCA to the V-PCRF to provide the PCC Rules. The H-PCRF sends applicable PCC rules. The H-PCRF includes the AN-GW-Address AVP if the PCC rules are applicable only for a single BBERF. If the PCC rules are applicable for all BBERF sessions this AVP is omitted.
10. If the steps 6~9 are executed, the V-PCRF enforces visited operator policies regarding QoS authorization requested by the H-PCRF as indicated by the roaming agreements.

Steps 10a and 10b are executed if the V-PCRF denies authorisation for one or more PCC rules.

10a. If V-PCRF denies authorization, it informs the H-PCRF by sending a CCR command including the Charging-Rule-Report AVP to indicate the PCC Rules that were not accepted, the Rule-Failure-Code AVP set to UNSUCCESSFUL-QoS-VALIDATION, and the acceptable QoS Information for the service.

10b. The H-PCRF may provide new modified PCC rules to the V-PCRF.

11. The V-PCRF acknowledges the IP-CAN session modification request by sending a Diameter CCA to the PCEF. The V-PCRF includes updated PCC rules and event triggers (if applicable)
12. The V-PCRF initiates the Gateway Control Session and QoS rules provisions by sending a Diameter RAR to the BBERF policy decisions and event triggers to the target BBERF.
13. The BBERF installs the received QoS Rules.
14. The BBERF acknowledges the Gateway Control and QoS Rules Provision request by sending a Diameter RAA to the V-PCRF.

5 Binding Mechanism

5.1 Overview

The binding mechanism associates the session information with the IP-CAN bearer that is intended to carry the service data flow.

The binding mechanism includes three steps as defined in 3GPP TS 23.203 [4]:

1. Session binding.
2. PCC Rule authorization and QoS Rule generation.
3. Bearer binding.

The Session Binding function receives the Session Information and determines the relevant IP-CAN session. With this information the PCC Rule Authorization and QoS Rule generation function runs the policy rules and constructs the PCC rule(s) and if applicable, the QoS rule(s) if the authorization is granted. Finally the Bearer Binding function selects the IP-CAN bearer where the PCC rule(s) or QoS rule(s) should be installed within the IP-CAN session already known.

PCC Rule Authorization and QoS Rule generation function and Bearer Binding function can take place without Session Binding at certain IP-CAN Session events (e.g. IP-CAN Session Establishment).

5.2 Session Binding

Session binding is the association of the AF session information to an IP-CAN session.

When the PCRF accepts an AA-Request from the AF over the Rx interface with service information, the PCRF shall perform session binding and associate the described service IP flows within the AF session information (and therefore the applicable PCC rules) to an existing IP-CAN session. This association is done comparing the user IP address received via the Rx interface in either the Frame-IP-Address AVP or the Framed-IPv6-Prefix AVP with the IPv4 address or IPv6 prefix received via the Gx interface. The UE Identity if present in the Subscription-Id AVP and the PDN information if available in the Called-Station-Id AVP may also assist on this association.

The PCRF will determine that the UE has an IP-CAN session if the IP address (IPv4 or IPv6) received over the Rx interface matches the IPv4 address or IPv6 prefix received via one or more of the following interfaces: Gx interface and S9 interface, and if the UE identity is used to assist the association, the UE identity received over the Rx interface matches the UE identity received via one or more of the following interfaces: Gx interface and S9 interface.

NOTE 1: In case the UE identity in the IP-CAN and the application level identity for the user are of different kinds, the PCRF needs to maintain, or have access to, the mapping between the identities. Such mapping is not subject to specification within this TS.

NOTE 2: An IPv6 address provided over Rx matches an IPv6 prefix provided over Gx or S9 if the IPv6 address belongs to the IPv6 (sub-)network prefix.

As a result from the session binding function, the PCRF identifies what IP-CAN session the current AF session is related with. If the PCRF is not capable of executing the Session Binding, the PCRF shall issue an AA-Answer command to the AF with a negative response.

5.3 PCC Rule Authorization and QoS Rule Generation

The PCRF shall perform the PCC rule authorization and QoS rule generation when the PCRF receives session information from an AF over Rx interface, when the PCRF receives notification of IP-CAN session events (e.g. establishment, modification) from the PCEF over Gx or S9 interface, or when the PCRF receives IP-CAN events from the BBERF over Gxa/Gxc interface. The PCRF shall also perform PCC Rule Authorization and QoS rule generation for dynamic PCC Rules already provisioned to the PCEF and dynamic QoS rules already provisioned to the BBERF due to internal PCRF triggers (e.g. policies are included or modified within PCRF).

If the PCRF receives any traffic mapping information from the BBF that does not match any service data flow filter, the PCRF shall also perform PCC and/or QoS rule authorization when the UE's subscriber profile allows subscription based authorization. In this case, the PCRF shall treat the received traffic mapping information as if it is service data flow filter information.

The PCRF assigns appropriate QoS parameters (QCI, ARP, GBR, MBR, etc.) to each PCC or QoS rule.

The PCRF authorizes the affected PCC rules and /or QoS rules after successful Session Binding. By the authorization process the PCRF will determine whether the user can have access to the requested services and under what constraints. If so, the PCC rules and QoS rules are created or modified. If the Session Information is not authorized, a negative answer shall be issued to the AF by sending an AA-Answer command.

The PCRF assigns an appropriate QCI to each PCC or QoS rule. IP-CAN specific restrictions and other information available to the PCRF (e.g. users subscription information, operator policies) shall be taken into account. Each PCC or QoS rule shall receive a QCI that can be supported by the IP-CAN. The PCRF shall ensure consistency between the QoS rules and PCC rules authorized for the same service data flow when QoS rules are derived from corresponding PCC rules.

In roaming scenarios, the V-PCRF may further authorize the rules received from the H-PCRF based on local operator policy. Depending on the local policy, the V-PCRF may change the authorized QoS for the affected rules. If local authorization of the rules fails, the V-PCRF shall issue a negative answer to the H-PCRF.

5.4 Bearer Binding

The Bearer Binding function is responsible for associating a PCC rule and QoS rule (if applicable) to an IP-CAN bearer within the IP-CAN session. The QoS demand in the rule, as well as the service data flow template, is input to the bearer binding. The selected bearer shall have the same QCI and ARP as the one indicated by the PCC or QoS rule.

The Bearer Binding Function (BBF) is located either at the BBERF or at the PCEF.

The PCRF shall supply the PCC rules to be installed, modified or removed over Gx interface to PCEF. If there are gateway controls sessions associated with the Gx session, the PCRF shall also supply the QoS rules to be installed, modified, or removed over Gxa/Gxc interface to the BBERF.

The BBF shall then check the QoS class identifier and ARP indicated by the rule and bind the rule with an IP-CAN bearer that has the same QoS class identifier and ARP. The BBF shall evaluate whether it is possible to use one of the existing IP-CAN bearers or not and, if applicable, whether to initiate IP-CAN bearer modification or not. If none of the existing bearers are possible to use, the BBF should initiate the establishment of a suitable IP-CAN bearer.

NOTE: For an IP-CAN, limited to a single IP-CAN bearer per IP-CAN session, the bearer is implicit, so finding the IP-CAN session is sufficient for successful bearer binding.

NOTE: The handling of a rule with MBR>GBR is up to operator policy (e.g. an independent IP-CAN bearer may be maintained for that SDF to prevent unfairness between competing SDFs).

NOTE: The QCI and ARP (including the Priority-Level, Pre-emption-Capability and Pre-emption-Vulnerability) are used for the bearer binding. Depending on operator policy, only the QCI and ARP Priority-Level can be used for bearer binding. In such a case, it is left to operator policy to determine whether different PCC rules with the same QCI and ARP Priority-Level but different Pre-emption-Capability and Pre-emption-Vulnerability can be bound to the same bearer.

For an IP-CAN, where the BBF gains no information on what IP-CAN bearer the UE selects to send an uplink IP flow on, the binding mechanism shall assume that, for bi-directional service data flows, both downlink and uplink packets travel on the same IP-CAN bearer.

Whenever the service data flow template, the QoS authorization or the negotiated traffic mapping information change, the existing bearer bindings shall be re-evaluated. The re-evaluation may, for a service data flow, require a new binding with another IP-CAN bearer.

During PCC/QoS rules enforcement, if packet filters are provided to the UE, the BBF shall provide packet filters with the same content as that in the SDF template filters received over the Gx/Gxx interface from the PCRF within the Flow-Description or the Flow-Information AVP. The representation/format of the packet filters provided by the network to the UE is access-system dependent and may vary between accesses and also may be different from that of the SDF template filter on the Gx/Gxx interface.

Requirements specific for each type of IP-CAN are defined in the IP-CAN specific Annex. The Bearer Binding Function may also be located in the PCRF (e.g. as specified in Annex D for GPRS running UE only IP-CAN bearer establishment mode). Selection of the Bearer Binding location shall be based on the Bearer Control Mode selected by the PCRF.

6 QoS Parameters Mapping

6.1 Overview

Several QoS parameters mapping functions are needed during PCC interaction. These functions are located at the AF, PCRF, PCEF and UE. The main purpose of these mapping functions is the conversion of QoS parameters from one format to another. Examples of QoS information are:

- Parts of a session description language (SDI), e.g. SDP.
- IP QoS parameters.
- Access specific QoS parameters.

One QoS mapping function is located at the AF, which maps the application specific information into the appropriate AVPs that are carried over the Rx interface. The AF derives information about the service from the SDI or from other sources. The mapping is application specific. If SDP (IETF RFC 2327[11]) is used as SDI, the AF should apply the mapping described in Clause 6.2. For IMS, the mapping rules in Clause 6.2 shall be used at the P-CSCF. The AF passes service information to the PCRF over the Rx interface. Clause 6.2 specifies the QoS parameter mapping functions at the AF applicable for all IMS P-CSCFs regardless of the access technology.

One QoS mapping function is located at the PCRF, which maps the service information received over the Rx interface into IP QoS parameters (e.g. QCI, GBR, MBR, ARP, ...). This mapping is access independent. Clause 6.3 specifies the QoS mapping functions at the PCRF applicable for all accesses.

The other mapping functions located at PCEF, BBERF, and UE are implementation dependent and are not specified within this specification except for GPRS case.

The PCRF notes and authorizes the IP flows described within this service information by mapping from service information to Authorized IP QoS parameters for transfer to the PCEF/BBERF via the Gx/Gxx interface. Both the PCEF and BBERF will map from the Authorized IP QoS parameters to the access specific QoS parameters. For GPRS, the GGSN acting as PCEF will map from the Authorized IP QoS parameters to the Authorized UMTS QoS parameters.

The general QoS mapping framework is shown in figure 6.1.1.

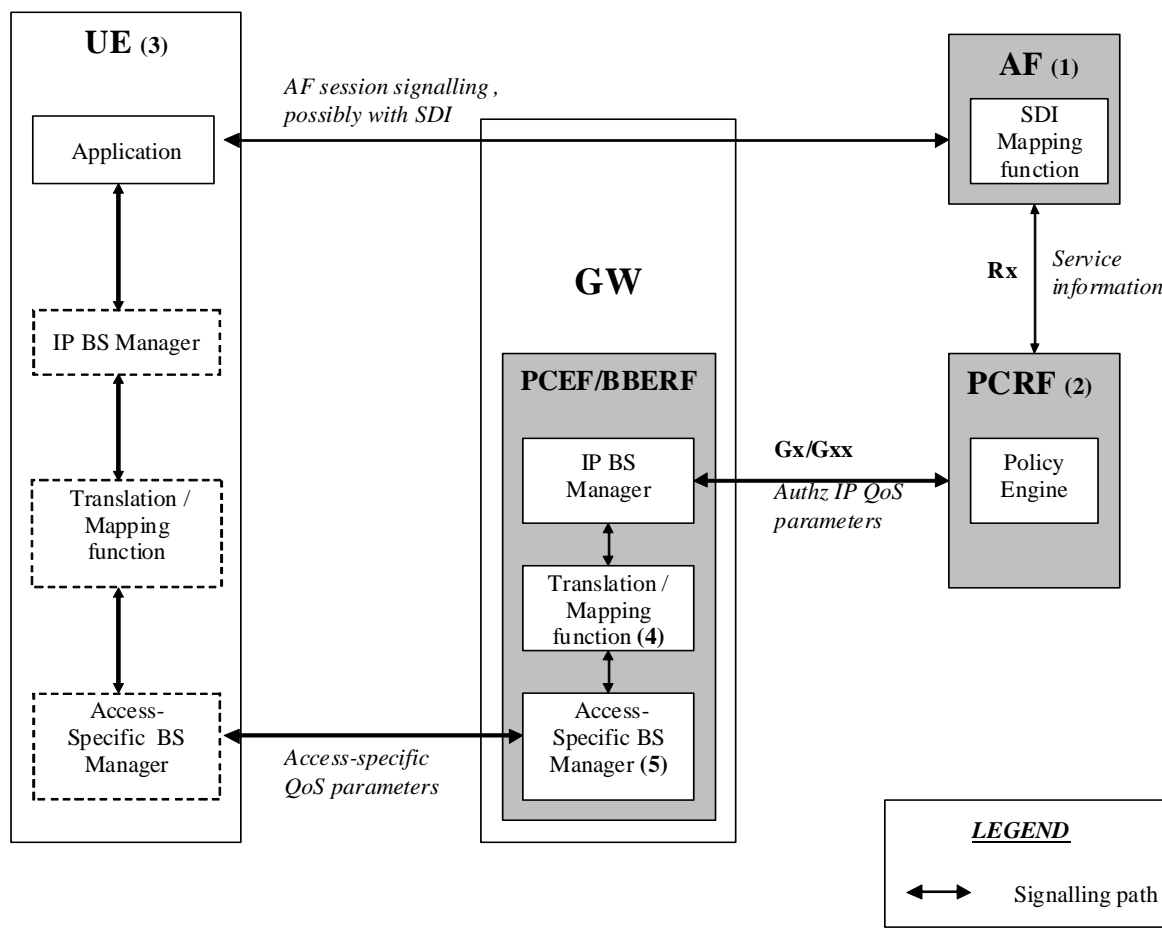

- NOTE 1: The AF can derive the Service information from the AF session signalling.
- NOTE 2: Service Information on Rx interface to Authorized IP QoS parameters mapping.
- NOTE 3: For the UE initiated bearer setup, the UE may derive IP QoS parameters, requested Access-Specific QoS parameters mapping and Authorized Access-Specific QoS parameters from the AF session signalling.
- NOTE 4: Authorized IP QoS parameters to Authorized Access-Specific QoS parameters mapping.
- NOTE 5: Access Specific QoS parameters with Authorized Access-Specific QoS parameters comparison.

Figure 6.1.1: Framework for QoS mapping

6.1.1 UE-Initiated IP-CAN bearers

This clause covers the case where the UE is capable to initiate/modify the IP-CAN bearers sending requests to the PCEF/BBBERF. When a UE desires to establish/modify an IP-CAN bearer the following steps are followed:

1. The AF can map from SDI within the AF session signalling to service information passed to the PCRF over the Rx interface. (see clause 6.2).
2. The PCRF shall map from the service information received over the Rx interface to the Authorized IP QoS parameters that shall be passed to the PCEF/BBBERF via the Gx/Gxx interface. The mapping is performed for each IP flow. Upon a request from the PCEF/BBBERF, the PCRF combines per direction the individual Authorized IP QoS parameters per flow (see clause 6.3).
3. The UE derives access specific QoS parameters, e.g. UMTS QoS parameters, and, if an IP BS manager is present, IP QoS parameters from the AF session signalling in an application specific manner. The IP and access specific QoS parameters should be generated according to application demands.

For GPRS, the recommendations for conversational (3GPP TS 26.236 [7]) or streaming applications (3GPP TS 26.234 [6]) should also be taken into account when the UE derives the IP and UMTS QoS parameters. If SDP is used as SDI, e.g. for IMS, the UE should apply clause 6.5.1 and should also apply mapping rules for the authorised QoS parameters in clause 6.5.2 to derive the maximum values for the different requested bit rates and traffic classes. In case the UE multiplexes several IP flows onto the same PDP Context, it has to combine their IP and UMTS QoS parameters. If an IP BS manager is present, the Translation/Mapping function maps the IP QoS parameters to the corresponding UMTS QoS parameters.

4. The PCEF/BBBERF shall map from the Authorized IP QoS parameters received from PCRF to the Authorized access specific QoS parameters.

For GPRS, the GGSN shall map to the Authorized UMTS QoS parameters (see clause 6.4.1.1).

5. The PCEF/BBBERF shall compare the requested access specific QoS parameters against the authorized access specific QoS parameters.

For GPRS, the GGSN shall compare the UMTS QoS parameters of the PDP context against the Authorized UMTS QoS parameters (see clause 6.4.1.2).

The mapping that takes place in the UE and the network should be compatible in order to ensure that the PCEF will be able to correctly authorize the session.

Figure 6.1.1.1 shows the different kind of QoS parameters in the different points of QoS mapping figure. Due to the UE requests, there are bidirectional flows between the UE and the PCRF.

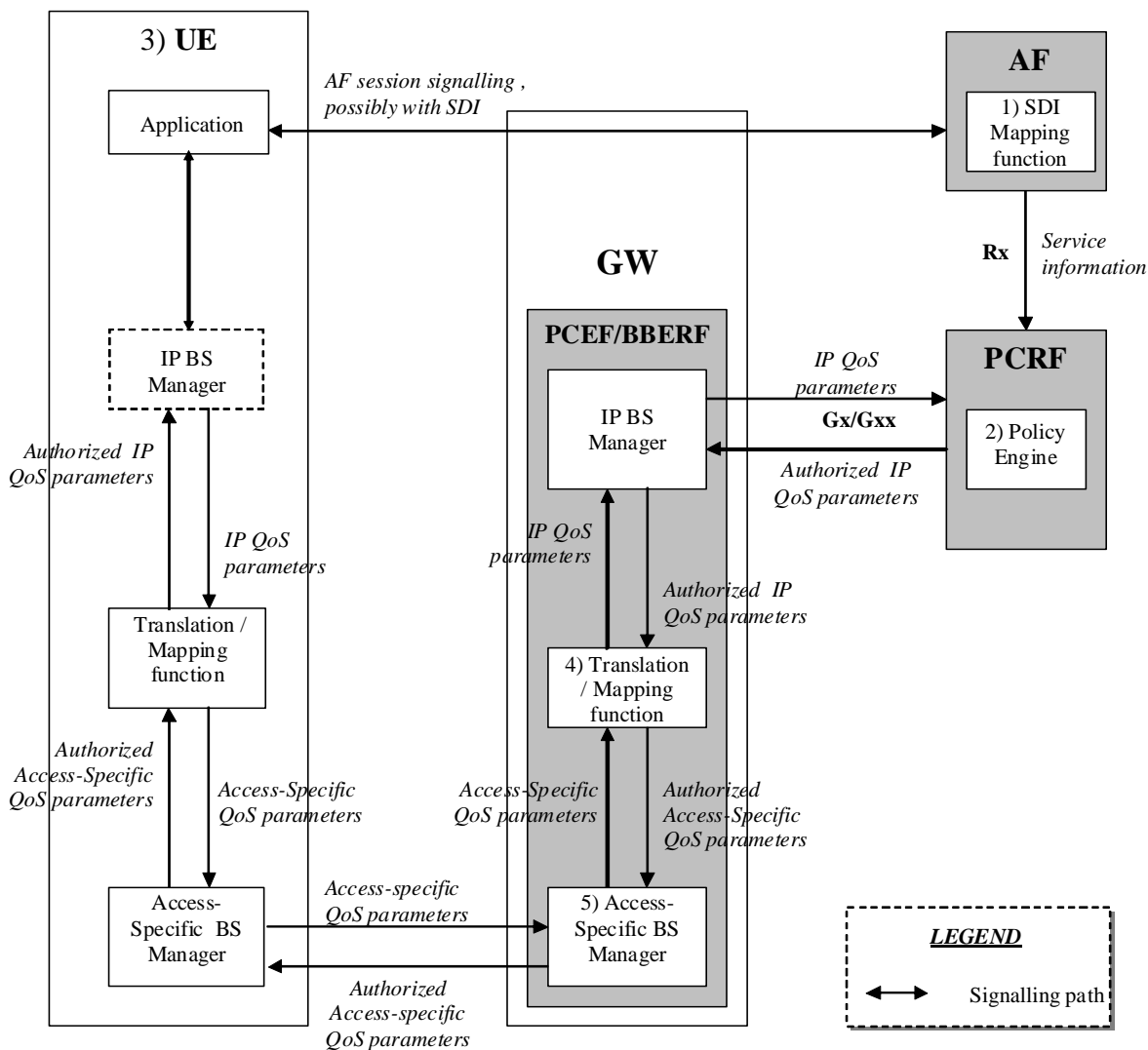

Figure 6.1.1.1: QoS mapping for UE initiated IP CAN bearers

6.1.2 Network-Initiated IP-CAN bearers

When the IP-CAN session supports Network-Initiated bearers, the network sets up IP CAN bearer(s) with a suitable QoS. If the type of IP CAN supports such an indication, the network indicates to the terminal the QoS characteristics of those IP-CAN bearer(s). Therefore the flow of QoS related information will be unidirectional as indicated in the figure 6.1.2.1.

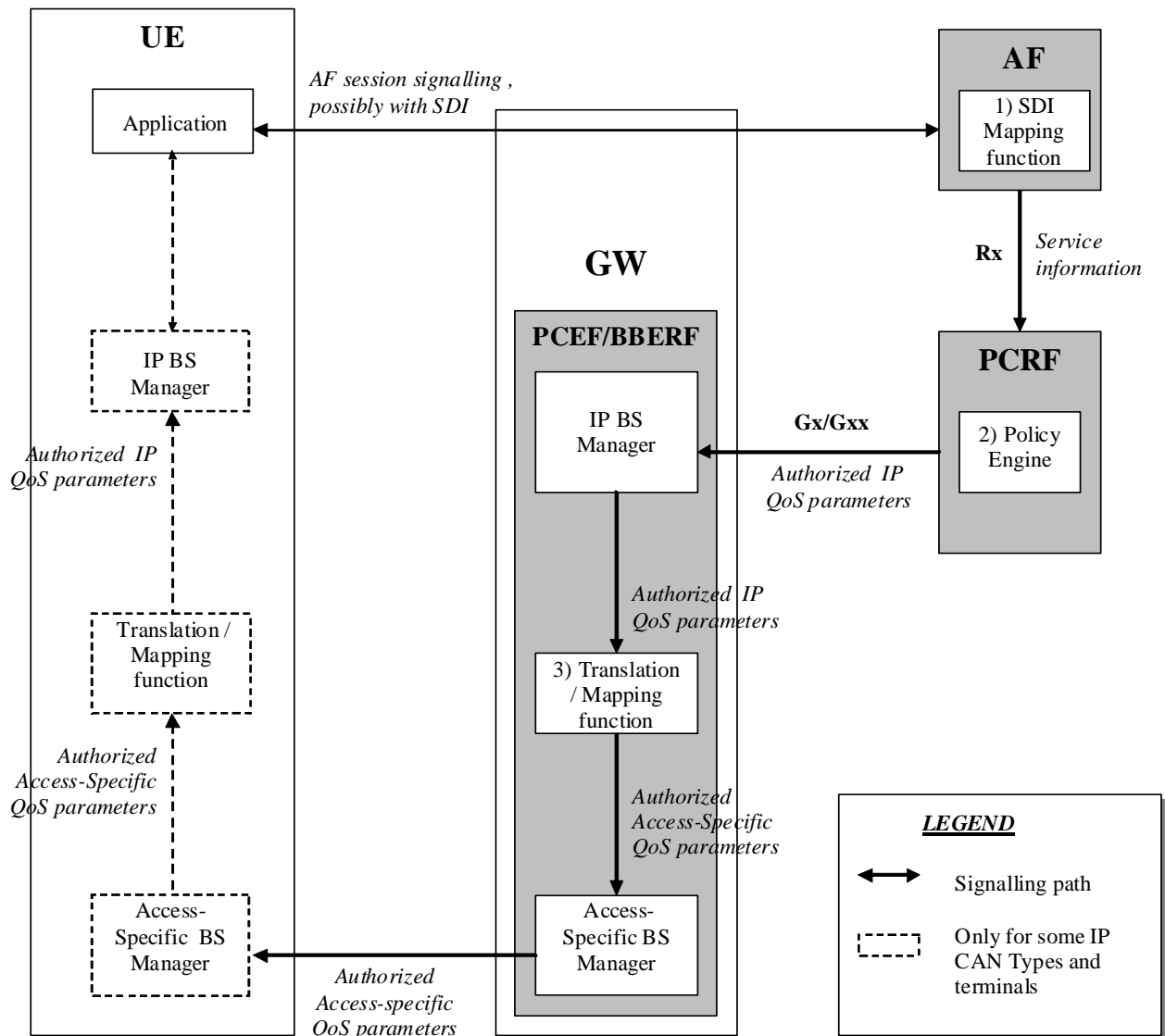

Figure 6.1.2.1: QoS mapping for network initiated IP CAN bearers

1. The AF can map from SDI within the AF session signalling to service information passed to the PCRF over the Rx interface (see clause 6.2).
2. The PCRF shall map from the service information received over the Rx interface to the Authorized IP QoS parameters that shall be passed to the PCEF/BBERF via the Gx/Gxx interface. The mapping is performed for each IP flow. Upon a request from the PCEF/BBERF, the PCRF combines per direction the individual Authorized IP QoS parameters per flow (see clause 6.3).
3. The PCEF/BBERF shall map from the Authorized IP QoS parameters received from PCRF to the access specific QoS parameters. For GPRS, the GGSN shall map to the UMTS QoS parameters (see clause 6.4.1.1).

6.2 QoS parameter mapping Functions at AF

The mapping described in this clause is mandatory for the P-CSCF and should also be applied by other AFs, if the SDI is SDP.

When a session is initiated or modified the P-CSCF shall use the mapping rules in table 6.2.1 for each SDP media component to derive a Media-Component-Description AVP from the SDP Parameters. The mapping shall not apply to media components where the SDP payload is proposing to use a circuit-switched bearer (i.e. "c=" line set to "PSTN" and an "m=" line set to "PSTN", refer to 3GPP TS 24.292 [24]). Circuit-switched bearer related media shall not be included in the service information sent to the PCRF.

Table 6.2.1: Rules for derivation of service information within Media-Component-Description AVP from SDP media component

service information per Media-Component-Description AVP (see notes 1 and 7)	Derivation from SDP Parameters (see note 2)
Media-Component-Number	ordinal number of the position of the "m=" line in the SDP
AF-Application-Identifier	The AF-Application-Identifier AVP may be supplied or omitted, depending on the application. For IMS, if the AF-Application-Identifier AVP is supplied, its value should not demand application specific bandwidth or QoS class handling unless the IMS application is capable of handling a QoS downgrading.
Media-Type	The Media Type AVP shall be included with the same value as supplied for the media type in the "m=" line.
Flow-Status	<pre> IF port in m-line = 0 THEN Flow-Status:= REMOVED; ELSE IF Transport in m-line is "TCP" or " TCP/MSRP" THEN (NOTE 9) Flow-Status := ENABLED; ELSE /* UDP or RTP/AVP transport IF a=recvonly THEN IF <SDP direction> = UE originated (NOTE 8) THEN Flow-Status := ENABLED_DOWNLINK; (NOTE 4) ELSE /* UE terminated (NOTE 8) */ Flow-Status := ENABLED_UPLINK; (NOTE 4) ENDIF; ELSE IF a=sendonly THEN IF <SDP direction> = UE originated (NOTE 8) THEN Flow-Status := ENABLED_UPLINK; (NOTE 4) ELSE /* UE terminated (NOTE 8) */ Flow-Status := ENABLED_DOWNLINK; (NOTE 4) ENDIF; ELSE IF a=inactive THEN Flow-Status :=DISABLED; ELSE /* a=sendrecv or no direction attribute */ Flow-Status := ENABLED (NOTE 4) ENDIF; ENDIF; ENDIF; ENDIF; ENDIF; (NOTE 5) </pre>
Max-Requested-Bandwidth-UL	<pre> IF <SDP direction> = UE terminated (NOTE 8) THEN IF Transport in m-line is "TCP" or " TCP/MSRP" THEN (NOTE 9) IF a=recvonly or a=sendrecv or no direction attribute THEN IF b=AS:<bandwidth> is present and (b=TIAS:<Tibandwidth> is not present or is present but not supported) THEN Max-Requested-Bandwidth-UL:= <bandwidth> * 1000; /* Unit bit/s ELSE IF b=TIAS:<Tibandwidth> is present and supported THEN Max-Requested-Bandwidth-DL:= <Transport-dependent bandwidth> (NOTE 11) /* Unit bit/s ELSE Max-Requested-Bandwidth-UL:= <Operator specific setting>; ENDIF; ELSE Max-Requested-Bandwidth-UL:= <Operator specific setting>, (NOTE 10) ENDIF; ELSE /* UDP or RTP/AVP transport IF b=AS:<bandwidth> is present and b=TIAS:<Tibandwidth> is not present or is present but not supported THEN Max-Requested-Bandwidth-UL:= <bandwidth> * 1000; /* Unit is bit/s ELSE IF b=TIAS:<Tibandwidth> is present and supported THEN Max-Requested-Bandwidth-DL:= <Transport-dependent bandwidth> (NOTE 11) /* Unit bit/s ELSE Max-Requested-Bandwidth-UL:= <Operator specific setting>, or AVP not supplied; ENDIF; ENDIF; ENDIF; ENDIF ENDIF ELSE Consider SDP in opposite direction ENDIF </pre>

service information per Media-Component-Description AVP (see notes 1 and 7)	Derivation from SDP Parameters (see note 2)
Max-Requested-Bandwidth-DL	<pre> IF <SDP direction> = UE originated (NOTE 8) THEN IF Transport in m-line is "TCP" or " TCP/MSRP" THEN (NOTE 9) IF a=recvonly or a=sendrecv or no direction attribute THEN IF b=AS:<bandwidth> is present and b=TIAS:<TIbandwidth> is not Present or is present but not supported THEN Max-Requested-Bandwidth-DL:= <bandwidth> * 1000; /* Unit bit/s IF b=TIAS:<TIbandwidth> is present and supported THEN Max-Requested-Bandwidth-DL:= <Transport-dependant bandwidth>/* Unit bit/s (see NOTE 11) OR Operator specific setting ELSE Max-Requested-Bandwidth-DL:= <Operator specific setting>; ENDIF; ELSE Max-Requested-Bandwidth-DL:= <Operator specific setting>, (NOTE 10) ENDIF; ELSE /* UDP or RTP/AVP transport IF b=AS:<bandwidth> is present and b=TIAS:<TIbandwidth> is not present THEN Max-Requested-Bandwidth-DL:= <bandwidth> * 1000; /* Unit is bit/s ELSE IF b=TIAS:<TIbandwidth> is present THEN Max-Requested-Bandwidth-DL:= <Transport-dependent bandwidth> (NOTE 11) /* Unit bit/s ELSE Max-Requested-Bandwidth-DL:= <Operator specific setting>, or AVP not supplied; ENDIF; ENDIF; ENDIF ENDIF Consider SDP in opposite direction ENDIF </pre>
RR-Bandwidth	<pre> IF b=RR:<bandwidth> is present THEN RR-Bandwidth:= <bandwidth>; ELSE AVP not supplied ENDIF; (NOTE 3; NOTE 6) </pre>
RS-Bandwidth	<pre> IF b=RS:<bandwidth> is present THEN RS-Bandwidth:= <bandwidth>; ELSE AVP not supplied ENDIF; (NOTE 3: NOTE 6) </pre>

service information per Media-Component-Description AVP (see notes 1 and 7)	Derivation from SDP Parameters (see note 2)
Media-Sub-Component	Supply one AVP for bidirectional combination of two corresponding IP flows, if available, and for each single IP flow without a corresponding IP flow in opposite direction. The encoding of the AVP is described in Table 6.2.2
Reservation-Priority	The AF may supply or omit this AVP.
Codec-Data	Codec Data AVP(s) are provisioned as specified in Clause 5.3.16 of 3GPP TS 29.214 [10], including the codec-related information detailed in Clause 5.3.7 of 3GPP TS 29.214 [10].
<p>NOTE 1: The encoding of the service information is defined in 3GPP TS 29.214 [10].</p> <p>NOTE 2: The SDP parameters are described in RFC 2327 [11].</p> <p>NOTE 3: The 'b=RS:' and 'b=RR:' SDP bandwidth modifiers are defined in RFC 3556 [13].</p> <p>NOTE 4: As an operator policy to disable forward and/or backward early media, for media with UDP as transport protocol only the Flow-Status may be downgraded before a SIP dialogue is established, i.e. until a 200 OK(INVITE) is received. The Value "DISABLED" may be used instead of the Values "ENABLED_UPLINK" or "ENABLED_DOWNLINK". The Values "DISABLED", "ENABLED_UPLINK" or "ENABLED_DOWNLINK" may be used instead of the Value "ENABLED".</p> <p>NOTE 5: If the SDP answer is available when the session information is derived, the direction attributes and port number from the SDP answer shall be used to derive the flow status. However, to enable interoperability with SIP clients that do not understand the inactive SDP attribute, if a=inactive was supplied in the SDP offer, this shall be used to derive the flow status. If the SDP answer is not available when the session information is derived, the direction attributes from the SDP offer shall be used.</p> <p>NOTE 6: Information from the SDP answer is applicable, if available.</p> <p>NOTE 7: The AVPs may be omitted if they have been supplied in previous service information and have not changed, as detailed in 3GPP TS 29.214 [10].</p> <p>NOTE 8: 'Uplink SDP' indicates that the SDP was received from the UE and sent to the network. This is equivalent to <SDP direction> = UE originated. 'Downlink SDP' indicates that the SDP was received from the network and sent to the UE. This is equivalent to <SDP direction> = UE terminated.</p> <p>NOTE 9: Support for TCP at a P-CSCF acting as AF is only required if services with TCP transport are used in the corresponding IMS system. As an operator policy to disable forward and/or backward early media, for media with TCP as transport protocol, the Max-Requested-Bandwidth-UL/DL values may be downgraded before a SIP dialogue is established, i.e. until a 200 OK(INVITE) is received. Only a small bandwidth in both directions is required in this case in order for TCP control packets to flow.</p> <p>NOTE 10: TCP uses IP flows in the directionality opposite to the transferred media for feedback. To enable these flows, a small bandwidth in this direction is required.</p> <p>NOTE 11: TIAS is defined in IETF RFC 3890 [23]. RFC 3890 section 6.4 provides procedures for converting TIAS to transport-dependant values. This procedure relies on the presence of maxprate (also defined in RFC 3890).</p>	

Table 6.2.2: Rules for derivation of Media-Sub-Component AVP from SDP media component

service information per Media-Sub-Component AVP (see notes 1 and 5)	Derivation from SDP Parameters (see note 2)
Flow-Number	<p>The AF shall assign a number to the media-subcomponent AVP that is unique within the surrounding media component AVP and for the entire lifetime of the AF session. The AF shall select the ordinal number of the IP flow(s) within the "m=" line assigned in the order of increasing downlink destination port numbers, if downlink destination port numbers are available. For uplink or inactive unicast media IP flows, a downlink destination port number is nevertheless available, if SDP offer-answer according to RFC 3264 is used.</p> <p>The AF shall select the ordinal number of the IP flow(s) within the "m=" line assigned in the order of increasing uplink destination port numbers, if no downlink destination port numbers are available.</p>
Flow-Status	AVP not supplied
Max-Requested-Bandwidth-UL	AVP not supplied
Max-Requested-Bandwidth-DL	AVP not supplied
Flow-Description	<p>For uplink and downlink direction, a Flow-Description AVP shall be provided unless no IP Flows in this direction are described within the media component.</p> <p>If UDP is used as transport protocol, the SDP direction attribute (NOTE 4) indicates the direction of the media IP flows within the media component as follows:</p> <pre> IF a=recvonly THEN (NOTE 3) IF <SDP direction> = UE originated (NOTE 7) THEN Provide only downlink Flow-Description AVP ELSE /* UE terminated (NOTE 7) */ Provide only uplink Flow-Description AVP ENDIF; ELSE IF a=sendonly THEN (NOTE 3) IF <SDP direction> = UE originated (NOTE 7) THEN Provide only uplink Flow-Description AVP ELSE /* UE terminated (NOTE 7) */ Provide only downlink Flow-Description AVP ENDIF; ELSE /* a=sendrecv or a=inactive or no direction attribute */ Provide uplink and downlink Flow-Description AVPs ENDIF; ENDIF; </pre> <p>However, for RTCP IP flows uplink and downlink Flow-Description AVPs shall be provided irrespective of the SDP direction attribute.</p> <p>If TCP is used as transport protocol (NOTE 8), IP flows in uplink and downlink direction are described in SDP irrespective of the SDP direction attribute, as TCP uses an IP flow for feedback even if contents are transferred only in the opposite direction. Thus, both uplink and downlink Flow-Description AVPs shall be provided.</p> <p>The uplink destination address shall be copied from the "c=" line of downlink SDP. (NOTE 6) (NOTE 7)</p> <p>The uplink destination port shall be derived from the "m=" line of downlink SDP. (NOTE 6) (NOTE 7) However, for TCP transport the uplink destination port shall be wildcarded, if the local UE is the passive endpoint (NOTE 9)</p> <p>The downlink destination address shall be copied from the "c=" line of uplink SDP. (NOTE 6)</p> <p>The downlink destination port shall be derived from the "m=" line of uplink SDP. (NOTE 6) (NOTE 7) However, for TCP transport the downlink destination port shall be wildcarded, if the local UE is the active endpoint (NOTE 9).</p> <p>For IPv6, uplink and downlink source addresses shall either be derived from the prefix of the destination address or be wildcarded by setting to "any", as specified in 3GPP TS 29.214 [10]. If IPv4 is being utilized, the uplink source address shall either be set to the address contained in the "c=" line of the uplink SDP or be wildcarded, and the downlink source address shall either be set to the address contained in the "c=" line of the downlink SDP or be wildcarded. However, for TCP transport, if the local UE is the passive endpoint (NOTE 9), the uplink source address shall not be wildcarded. If the local UE is the active endpoint (NOTE 9), the downlink source address shall</p>

service information per Media-Sub-Component AVP (see notes 1 and 5)	Derivation from SDP Parameters (see note 2)
	<p>not be wildcarded.</p> <p>Source ports shall not be supplied. However, for TCP transport, if the local UE is the passive end point (NOTE 9), the uplink source port shall be derived from the 'm=' line of the uplink SDP. If the local UE is the active end point (NOTE 9), the downlink source port shall be derived from the 'm=' line of the downlink SDP.</p> <p>Proto shall be derived from the transport of the "m=" line. For "RTP/AVP" proto is 17(UDP). For "TCP", as defined in RFC 4145 [16], or "TCP/MSRP", as defined in RFC 4975 [17], proto is 6(TCP).</p>
Flow-Usage	<p>The Flow-Usage AVP shall be supplied with value "RTCP" if the IP flow(s) described in the Media-Sub-Component AVP are used to transport RTCP. Otherwise the Flow-Usage AVP shall not be supplied. RFC 2327 [11] specifies how RTCP flows are described within SDP.</p> <p>If the IP flows(s) are used to transport signaling the value should be "AF-SIGNALING"</p>
<p>NOTE 1: The encoding of the service information is defined in 3GPP TS 29.214 [10].</p> <p>NOTE 2: The SDP parameters are described in RFC 2327 [11].</p> <p>NOTE 3: If the SDP direction attribute for the media component negotiated in a previous offer-answer exchange was sendrecv, or if no direction attribute was provided, and the new SDP direction attribute sendonly or recvonly is negotiated in a subsequent SDP offer-answer exchange, uplink and downlink Flow-Description AVPs shall be supplied.</p> <p>NOTE 4: If the SDP answer is available when the session information is derived, the direction attributes from the SDP answer shall be used to derive the flow description. However, to enable interoperability with SIP clients that do not understand the inactive SDP attribute, if a=inactive was supplied in the SDP offer, this shall be used. If the SDP answer is not available when the session information is derived, the direction attributes from the SDP offer shall be used.</p> <p>NOTE 5: The AVPs may be omitted if they have been supplied in previous service information and have not changed, as detailed in 3GPP TS 29.214 [10].</p> <p>NOTE 6: If the session information is derived from an SDP offer, the required SDP may not yet be available. The corresponding Flow Description AVP shall nevertheless be included and the unavailable fields (possibly all) shall be wildcarded.</p> <p>NOTE 7: 'Uplink SDP' indicates that the SDP was received from the UE and sent to the network. This is equivalent to <SDP direction> = UE originated. 'Downlink SDP' indicates that the SDP was received from the network and sent to the UE. This is equivalent to <SDP direction> = UE terminated.</p> <p>NOTE 8: Support for TCP at a P-CSCF acting as AF is only required if services with TCP transport are used in the corresponding IMS system.</p> <p>NOTE 9: For TCP transport, the passive endpoints is derived from the SDP "a:setup" attribute according to the rules in RFC 4145 [16], or, if that attribute is not present, from the rules in RFC 4975 [17].</p>	

6.3 QoS parameter mapping Functions at PCRF

The QoS authorization process consists of the derivation of the parameters Authorized QoS Class Identifier (QCI), Allocation and Retention Priority (ARP), and Authorized Maximum/Guaranteed Data Rate UL/DL.

When a session is initiated or modified the PCRF shall derive Authorized IP QoS parameters (i.e. QCI, Authorized Maximum/Guaranteed Data Rate DL/UL, ARP) from the service information. If the selected Bearer Control Mode (BCM) is UE-only this process shall be performed according to the mapping rules in table 6.3.1 to avoid undesired misalignments with the UE QoS parameters mapping.

In the case of forking, the various forked responses may have different QoS requirements for the IP flows of the same media component. Each Authorized IP QoS Parameter should be set to the highest value requested for the IP flow(s) of that media component by any of the active forked responses.

Table 6.3.1: Rules for derivation of the Maximum Authorized Data Rates, Authorized Guaranteed Data Rates and Maximum Authorized QoS Class per IP flow or bidirectional combination of IP flows in the PCRF

Authorized IP QoS Parameter	Derivation from service information (see note 4)
Maximum Authorized Data Rate DL (Max_DR_DL) and UL (Max_DR_UL)	<pre> IF operator special policy exists THEN Max_DR_UL:= as defined by operator specific algorithm; Max_DR_DL:= as defined by operator specific algorithm; ELSE IF AF-Application-Identifier AVP demands application specific data rate handling THEN Max_DR_UL:= as defined by application specific algorithm; Max_DR_DL:= as defined by application specific algorithm; ELSE IF Codec-Data AVP provides Codec information for a codec that is supported by a specific algorithm THEN Max_DR_UL:= as defined by specific algorithm; Max_DR_DL:= as defined by specific algorithm; ELSE IF not RTCP flow(s) according to Flow-Usage AVP THEN IF Flow-Status = REMOVED THEN Max_DR_UL:= 0; Max_DR_DL:= 0; ELSE IF uplink Flow Description AVP is supplied THEN IF Max-Requested-Bandwidth-UL is present THEN Max_DR_UL:= Max-Requested-Bandwidth-UL ; ELSE Max_DR_UL:= as set by the operator; ENDIF; ELSE Max_DR_UL:= 0; ENDIF; IF downlink Flow Description AVPs is supplied THEN IF Max-Requested-Bandwidth-DL is present THEN Max_DR_DL:= Max-Requested-Bandwidth-DL; ELSE Max_DR_DL:= as set by the operator; ENDIF; ELSE Max_DR_DL:= 0; ENDIF; ENDIF; ELSE /* RTCP IP flow(s) */ IF RS-Bandwidth is present and RR-Bandwidth is present THEN Max_DR_UL:= (RS-Bandwidth + RR-Bandwidth); Max_DR_DL:= (RS-Bandwidth + RR-Bandwidth); ELSE IF Max-Requested-Bandwidth-UL is present THEN IF RS-Bandwidth is present and RR-Bandwidth is not present THEN Max_DR_UL:= MAX[0.05 * Max-Requested-Bandwidth-UL,RS-Bandwidth]; ENDIF; IF RS-Bandwidth is not present and RR-Bandwidth is present THEN Max_DR_UL:= MAX[0.05 * Max-Requested-Bandwidth-UL,RR-Bandwidth]; ENDIF; IF RS-Bandwidth and RR-Bandwidth are not present THEN Max_DR_UL:= 0.05 * Max-Requested-Bandwidth_UL ; ENDIF; ELSE Max_DR_UL:= as set by the operator; </pre>

Authorized IP QoS Parameter	Derivation from service information (see note 4)
	<pre> ENDIF; IF Max-Requested-Bandwidth-DL is present THEN IF RS-Bandwidth is present and RR-Bandwidth is not present THEN Max_DR_DL:= MAX[0.05 * Max-Requested-Bandwidth-DL,RS-Bandwidth]; ENDIF; IF RS-Bandwidth is not present and RR-Bandwidth is present THEN Max_DR_DL:= MAX[0.05 * Max-Requested-Bandwidth-DL,RR-Bandwidth]; ENDIF; IF RS-Bandwidth and RR-Bandwidth are not present THEN Max_DR_DL:= 0.05 * Max-Requested-Bandwidth-DL; ENDIF; ELSE Max_DR_DL:= as set by the operator; ENDIF; ENDIF; ENDIF; ENDIF; ENDIF; IF SIP-Forking-Indication AVP indicates SEVERAL_DIALOGUES THEN Max_DR_UL = MAX[Max_DR_UL, previous Max_DR_UL] Max_DR_DL = MAX[Max_DR_DL, previous Max_DR_DL] ENDIF; </pre>

Authorized IP QoS Parameter	Derivation from service information (see note 4)
Authorized Guaranteed Data Rate DL (Gua_DR_DL) and UL (Gua_DR_UL) (see NOTE 11)	<pre> IF operator special policy exists THEN Gua_DR_UL:= as defined by operator specific algorithm; Gua_DR_DL:= as defined by operator specific algorithm; ELSE IF AF-Application-Identifier AVP demands application specific data rate handling THEN Gua_DR_UL:= as defined by application specific algorithm; Gua_DR_DL:= as defined by application specific algorithm; ELSE IF Codec-Data AVP provides Codec information for a codec that is supported by a specific algorithm (NOTE 5) THEN Gua_DR_UL:= as defined by specific algorithm; Gua_DR_DL:= as defined by specific algorithm; ELSE Gua_DR_UL:= Max DR UL; Gua_DR_DL:= Max DR DL; ENDIF; ENDIF; IF SIP-Forking-Indication AVP indicates SEVERAL_DIALOGUES THEN Gua_DR_UL = MAX[Gua_DR_UL, previous Gua_DR_UL] Gua_DR_DL = MAX[Gua_DR_DL, previous Gua_DR_DL] ENDIF; </pre>
Authorized QoS Class Identifier [QCI] (see NOTE 1, 2, 3, 7, 12, and 13)	<pre> IF a operator special policy exists THEN QCI:= as defined by operator specific algorithm; ELSE IF AF-Application-Identifier AVP demands application specific QoS Class handling THEN QCI:= as defined by application specific algorithm; ELSE IF Codec-Data AVP provides Codec information for a codec that is supported by a specific algorithm THEN QCI:= as defined by specific algorithm; (NOTE 5) ELSE /* The following QCI derivation is an example of how to obtain the QCI values in a GPRS network */ IF Media-Type is present THEN /* for GPRS: streaming */ IF (only uplink Flow Description AVPs are supplied for all IP flows of the AF session, which have media type "audio" or "video" and no flow usage "RTCP", or only downlink Flow Description AVPs are supplied for all IP flows of the AF session, which have media type "audio" or "video" and no flow usage "RTCP") THEN CASE Media-Type OF "audio": MaxClassDerivation := 3 OR 4; (NOTE 9) "video": MaxClassDerivation := 4 END; /* for GPRS: conversational */ ELSE CASE Media-Type OF "audio": MaxClassDerivation:= 1 OR 2; (NOTE 6) "video": MaxClassDerivation:= 2 END; ENDIF; CASE Media-Type OF "audio": QCI := MaxClassDerivation "video": QCI := MaxClassDerivation "application": QCI := 1 OR 2; (NOTE 6) /*e.g. for GPRS: conversational*/ "data": QCI := 6 OR 7 OR 8; (NOTE 8) /*e.g. for GPRS: interactive with prio 1, 2 AND 3 respectively*/ "control": QCI := 6; /*e.g. for GPRS: interactive with priority 1*/ END; </pre>

Authorized IP QoS Parameter	Derivation from service information (see note 4)
	<pre> /* NOTE: include new media types here */ OTHERWISE: QCI := 9; /*e.g. for GPRS: background*/ END; ENDIF; ENDIF; IF SIP-Forking-Indication AVP indicates SEVERAL_DIALOGUES THEN QCI = MAX[QCI, previous QCI] (NOTE 10) ENDIF; </pre>
<p>NOTE 1: The QCI assigned to a RTCP IP flow is the same as for the corresponding RTP media IP flow.</p> <p>NOTE 2: When audio or video IP flow(s) are removed from a session, the parameter MaxClassDerivation shall keep the originally assigned value.</p> <p>NOTE 3: When audio or video IP flow(s) are added to a session, the PCRF shall derive the parameter MaxClassDerivation taking into account the already existing media IP flow(s) within the session.</p> <p>NOTE 4: The encoding of the service information is defined in 3GPP TS 29.214 [10]. If AVPs are omitted within a Media-Component-Description AVP or Media-Sub-Component AVP of the service information, the corresponding information from previous service information shall be used, as specified in 3GPP TS 29.214 [10].</p> <p>NOTE 5: 3GPP TS 26.234 [6] , 3GPP TS 26.236 [7] , 3GPP2 C.S0046 [18], and 3GPP2 C.S0055 [19] contain examples of QoS parameters for codecs of interest. The support of any codec specific algorithm in the PCRF is optional.</p> <p>NOTE 6: The final QCI value will depend on the value of SSID (speech/unknown) according to 3GPP TS 23.107 [4]. If the PCRF is not able to determine the SSID, it should use the QCI value 2 that corresponds to SSID unknown. For UE-init and mixed mode, the PCRF may derive from the requested QoS of an IP CAN bearer which SSID is applicable.</p> <p>NOTE 7: The numeric value of the QCI are based on 3GPP TS 29.212 [9].</p> <p>NOTE 8: The QCI value also encodes the traffic handling priority for GPRS. If the PCRF is not able to determine a traffic handling priority, it should choose QCI 8 that corresponds to priority 3. Also, for UE-initiated bearers the PCRF should only use QCI 8 in order to have the same mapping rules in both UE and PCRF.</p> <p>NOTE 9: The final QCI value will depend on the value of SSID (speech/unknown) according to 3GPP TS 23.107 [4]. If the PCRF is not able to determine the SSID, it should use the QCI value 4 that corresponds to SSID unknown. For UE-init and mixed mode, the PCRF may derive from the requested QoS of an IP CAN bearer which SSID is applicable.</p> <p>NOTE 10: The Max function shall use the following precedence order for the QCI values: 2 > 1 > 4 > 3 > 5 > 6 > 7 > 8 > 9</p> <p>NOTE 11: Authorized Guaranteed Data Rate DL and UL shall not be derived for QCI values 5, 6, 7, 8 and 9.</p> <p>NOTE 12: Recommended QCI values for standardised QCI characteristics are shown in table 6.1.7 in 3GPP TS 23.203 [2].</p> <p>NOTE 13: In a network where SRVCC is enabled, the QCI=1 shall be used for IMS services in accordance to 3GPP TS 23.216 [25]. Non-IMS services using QCI=1 may suffer service interruption and/or inconsistent service experience if SRVCC is triggered.</p>	

The PCRF should per ongoing session store the Authorized IP QoS parameters per for each IP flow or bidirectional combination of IP flows (as described within a Media Subcomponent AVP).

If the PCRF provides a QoS-Information AVP within a Charging-Rule-Definition AVP it may apply the rules in table 6.3.2 to combine the Authorized QoS per IP flow or bidirectional combination of IP flows (as derived according to table 6.3.1) for all IP flows described by the corresponding PCC rule.

If the PCRF provides a QoS-Information AVP for an entire IP CAN bearer (for a UE-initiated IP-CAN bearer in the GPRS case) or IP CAN session, it may apply the rules in table 6.3.2 to combine the Authorized QoS per IP flow or bidirectional combination of IP flows (as derived according to table 6.3.1) for all IP flows allowed to be transported within the IP CAN bearer or session. It is recommended that the rules in table 6.3.2 are applied for all IP flows with corresponding AF session. The PCRF may increase the authorized QoS further to take into account the requirements of predefined PCC rules without ongoing AF sessions.

NOTE: QoS-Information AVP provided at IP-CAN session level is not derived based on mapping tables, but based on subscription and operator specific policies.

NOTE: Allocation-Retention-Priority AVP is always calculated at PCC rule level according to table 6.3.2.

For a UE initiated PDP context within GPRS, the PCRF applies the binding mechanism described in Clause 5 to decide which flows are allowed to be transported within the IP CAN bearer.

Table 6.3.2: Rules for calculating the Maximum Authorized/Guaranteed Data Rates, QCI and ARP in the PCRF

Authorized IP QoS Parameter	Calculation Rule
Maximum Authorized Data Rate DL and UL	Maximum Authorized Data Rate DL/UL is the sum of all Maximum Authorized Data Rate DL/UL for all the IP flows or bidirectional combinations of IP flows (as according to table 6.3.1). IF Network = GPRS AND Maximum Authorized Data Rate DL/UL > 256 Mbps THEN Maximum Authorized Data Rate DL/UL = 256 Mbps /* See 3GPP TS 23.107 [4] */ ENDIF;
Guaranteed Authorized Data Rate DL and UL	Guaranteed Authorized Data Rate DL/UL is the sum of all Guaranteed Authorized Data Rate DL/UL for all the IP flows or bidirectional combinations of IP flows (as according to table 6.3.1).
QCI	QCI = MAX [needed QoS parameters per IP flow or bidirectional combination of IP flows (as operator"s defined criteria) among all the IP flows or bidirectional combinations of IP flows.]
ARP (see NOTE 1)	IF a operator special policy exists THEN ARP:= as defined by operator specific algorithm; ELSE IF AF-Application-Identifier AVP demands application specific ARP handling THEN ARP:= as defined by application specific algorithm; ENDIF; ELSE IF Reservation-Priority AVP demands application specific ARP handling THEN ARP:= as defined by application specific algorithm; ENDIF; ENDIF;
NOTE 1: The ARP priority levels 1-8 should only be assigned to resources for services that are authorized to receive prioritized treatment within an operator domain.	

6.4 QoS parameter mapping Functions at PCEF

6.4.1 GPRS

6.4.1.1 Authorized IP QoS parameters per PDP Context to Authorized UMTS QoS parameters mapping in GGSN

The Translation/Mapping function in the GGSN shall derive the Authorized UMTS QoS parameters from the Authorized IP QoS parameters received from the PCRF according to the rules in table 6.4.1.

Table 6.4.1: Rules for derivation of the Authorized UMTS QoS Parameters per PDP context from the Authorized IP QoS Parameters in GGSN

Authorized UMTS QoS Parameter per PDP context	Derivation from Authorized IP QoS Parameters
Maximum Authorized Bandwidth DL and UL per PDP context	Maximum Authorized Bandwidth DL/UL per PDP context = Maximum Authorized Data Rate DL/UL
Guaranteed Authorized Data Rate DL and UL per PDP context	Guaranteed Authorized Data Rate DL/UL per PDP context = Guaranteed Authorized Data Rate DL/UL
Maximum Authorized Traffic Class per PDP context	<pre> IF QCI = 1 OR 2 THEN Maximum Authorized Traffic Class = "Conversational" ELSEIF QCI = 3 OR 4 THEN Maximum Authorized Traffic Class = "Streaming" ELSEIF QCI = 5 OR 6 OR 7 OR 8 THEN Maximum Authorized Traffic Class = "Interactive"; ELSE Maximum Authorized Traffic Class = "Background" ENDIF ; </pre>
Traffic Handling Priority	<pre> IF QCI = 5 OR 6 THEN Maximum Authorized Traffic Handling Priority = "1"; ELSE IF QCI = 7 THEN Maximum Authorized Traffic Handling Priority = "2"; ELSE IF QCI = 8 THEN Maximum Authorized Traffic Handling Priority = "3"; ELSE the GGSN shall not derive Traffic Handling Priority ENDIF ; </pre>
Signalling Indication	<pre> IF QCI = 5 THEN Signalling Indication = "Yes"; ELSE IF QCI = 6 OR 7 OR 8 THEN Signalling Indication = "No"; ELSE the GGSN shall not derive Signalling Indication ENDIF ; </pre>
Source Statistics Descriptor	<pre> IF QCI = (1 OR 3) THEN Source Statistics Descriptor = "speech"; ELSE IF QCI = 2 OR 4 THEN Source Statistics Descriptor = "unknown"; ELSE the GGSN shall not derive Source Statistics Descriptor ENDIF ; </pre>

6.4.1.2 Comparing UMTS QoS Parameters against the Authorized UMTS QoS parameters in GGSN for UE initiated PDP context

Upon receiving a PDP context activation, the GGSN requests PCC rules from the PCRF (see 3GPP TS 29.212 [9] for details). The PCRF may supply Authorized IP QoS Parameters per PDP context together with the PCC rules. The GGSN maps the Authorized IP QoS parameters per PDP Context to Authorized UMTS QoS parameters according to clause 6.4.1.1 and then compares the requested UMTS QoS parameters against the corresponding Authorized UMTS QoS parameters. The following criteria shall be fulfilled:

- If the requested Guaranteed Bitrate DL/UL (if the requested Traffic Class is Conversational or Streaming) is equal to the Authorized Guaranteed data rate DL/UL; and

- the requested Maximum Bitrate DL/UL (if the requested Traffic Class is Interactive or Background) is equal to Maximum Authorized data rate DL/UL; and
- the requested Traffic Class is equal to Maximum Authorized Traffic Class.

Then, the GGSN shall accept the PDP context activation or modification with the UE requested parameters. Otherwise, the GGSN is adjusted (downgrade or upgrade) the requested UMTS QoS parameters to the values that were authorized.

6.4.2 3GPP- EPS

6.4.2.1 Authorized IP QoS parameters per PDP Context to Authorized UMTS QoS parameters mapping in P-GW.

This Translation/Mapping function in the P-GW applies when the P-GW interacts with a Gn/Gp SGSN.

The Translation/Mapping function in the P-GW shall derive the Authorized UMTS QoS parameters from the Authorized IP QoS parameters derived for the bearer applying the rules in table 6.4.2.

Table 6.4.2: Rules for derivation of the Authorized UMTS QoS Parameters per PDP context from the Authorized IP QoS Parameters in P-GW.

Authorized UMTS QoS Parameter per PDP context	Derivation from Authorized IP QoS Parameters
Maximum Authorized Bandwidth DL and UL per PDP context	<p>For non-GBR bearers, Maximum Authorized Bandwidth DL/UL per PDP context = APN-Aggregate-Max-Bitrate DL/UL</p> <p>For GBR bearers, Maximum Authorized Bandwidth DL/UL per PDP context = Sum of Maximum Authorized Data Rate DL/UL for all PCC Rules bound to that bearer</p>
Guaranteed Authorized Data Rate DL and UL per PDP context	Guaranteed Authorized Data Rate DL/UL per PDP context = Sum of Guaranteed Authorized Data Rate DL/UL for all PCC Rules bound to that bearer
Maximum Authorized Traffic Class per PDP context	<pre> IF QCI = 1 OR 2 OR 3 THEN Maximum Authorized Traffic Class = "Conversational" ELSEIF QCI = 4 THEN Maximum Authorized Traffic Class = "Streaming" ELSEIF QCI = 5 OR 6 OR 7 OR 8 THEN Maximum Authorized Traffic Class = "Interactive"; ELSE Maximum Authorized Traffic Class = "Background" ENDIF ; </pre>
Traffic Handling Priority	<pre> IF QCI = 5 OR 6 THEN Maximum Authorized Traffic Handling Priority = "1"; ELSE IF QCI = 7 THEN Maximum Authorized Traffic Handling Priority = "2"; ELSE IF QCI = 8 THEN Maximum Authorized Traffic Handling Priority = "3"; ELSE the P-GW shall not derive Traffic Handling Priority ENDIF ; </pre>
Signalling Indication	<pre> IF QCI = 5 THEN Signalling Indication = "Yes"; ELSE IF QCI = 6 OR 7 OR 8 THEN Signalling Indication = "No"; ELSE the P-GW shall not derive Signalling Indication ENDIF ; </pre>
Source Statistics Descriptor	<pre> IF QCI = 1 THEN Source Statistics Descriptor = "speech"; ELSE IF QCI = 2 OR 3 OR 4 THEN Source Statistics Descriptor = "unknown"; ELSE the P-GW shall not derive Source Statistics Descriptor ENDIF ; </pre>
Transfer Delay (see NOTE 1)	<pre> IF QCI = 2 THEN Transfer Delay = 150 ms ELSE IF QCI = 3 THEN Transfer Delay >= 80 ms ELSE IF QCI = 1 OR 4 the P-GW shall set the Transfer Delay as the Packet Delay Budget for that QCI ELSE the P-GW shall not derive Transfer Delay. ENDIF ; </pre>
<p>NOTE 1: Recommended Packet Delay Budget values for the different QCI values are defined in clause 6.1.7, 3GPP TS 23.203 [2].</p>	

6.4.2.2 Comparing UMTS QoS Parameters against the Authorized UMTS QoS parameters in P-GW for UE initiated PDP context

Upon receiving a PDP context activation, the P-GW requests PCC rules from the PCRF (see 3GPP TS 29.212 [9] for details). The PCRF may supply Authorized IP QoS Parameters applicable for the provided PCC rules. The P-GW calculates the Authorized IP QoS parameters per bearer and maps the Authorized IP QoS parameters per bearer to Authorized UMTS QoS parameters according to clause 6.4.2.1 and then compares the requested UMTS QoS parameters against the corresponding Authorized UMTS QoS parameters. The following criteria shall be fulfilled:

- If the requested Guaranteed Bitrate DL/UL (if the requested Traffic Class is Conversational or Streaming) is equal to the Authorized Guaranteed data rate DL/UL; and
- the requested Maximum Bitrate DL/UL (if the requested Traffic Class is Interactive or Background) is equal to Maximum Authorized data rate DL/UL; and
- the requested Traffic Class is equal to Maximum Authorized Traffic Class.

Then, the P-GW shall accept the PDP context activation with the UE requested parameters. Otherwise, the P-GW shall accept the request and adjust (downgrade or upgrade) the requested UMTS QoS parameters to the values that were authorized.

6.5 QoS parameter mapping Functions at UE for a UE-initiated GPRS PDP Context

Figure 6.5.1 indicates the entities participating in the generation of the requested QoS parameters when the UE activates or modifies a PDP Context. The steps are:

1. The Application provides the UMTS BS Manager, possibly via the IP BS Manager and the Translation/Mapping function, with relevant information to perform step 2 or step 4. (Not subject to standardization within 3GPP).
2. If needed, information from step 1 is used to access a proper set of UMTS QoS Parameters. See 3GPP TS 26.236 [7] for Conversational Codec Applications and 3GPP TS 26.234 [6] for Streaming Codec Applications.
3. If SDP is available then the SDP Parameters should give guidance for the UMTS BS Manager (possibly via the IP Manager and the Translation/Mapping function), according to the rules in clause 6.5.1, to set the Maximum Bitrate UL/DL and the Guaranteed Bitrate UL/DL. Furthermore the Maximum Authorized Bandwidth UL/DL and Maximum Authorized Traffic Class should be derived according to the rules in clause 6.5.2.
4. A set of UMTS QoS Parameters values from step 2 (or directly from step 1) is possibly merged together with the Maximum Bitrate UL/DL and the Guaranteed Bitrate UL/DL from step 3. The result should constitute the requested UMTS QoS Parameters. The UE should check that the requested Guaranteed Bitrate UL/DL or requested Maximum Bitrate UL/DL (depending on the requested Traffic Class) does not exceed the Maximum Authorized Bandwidth UL/DL derived in step 3. Furthermore, if the UE has implemented the mapping rule for Maximum Authorized Traffic Class, as defined in clause 6.5.2, the UE should check that the requested Traffic Class does not exceed the Maximum Authorized Traffic Class derived in step 3.

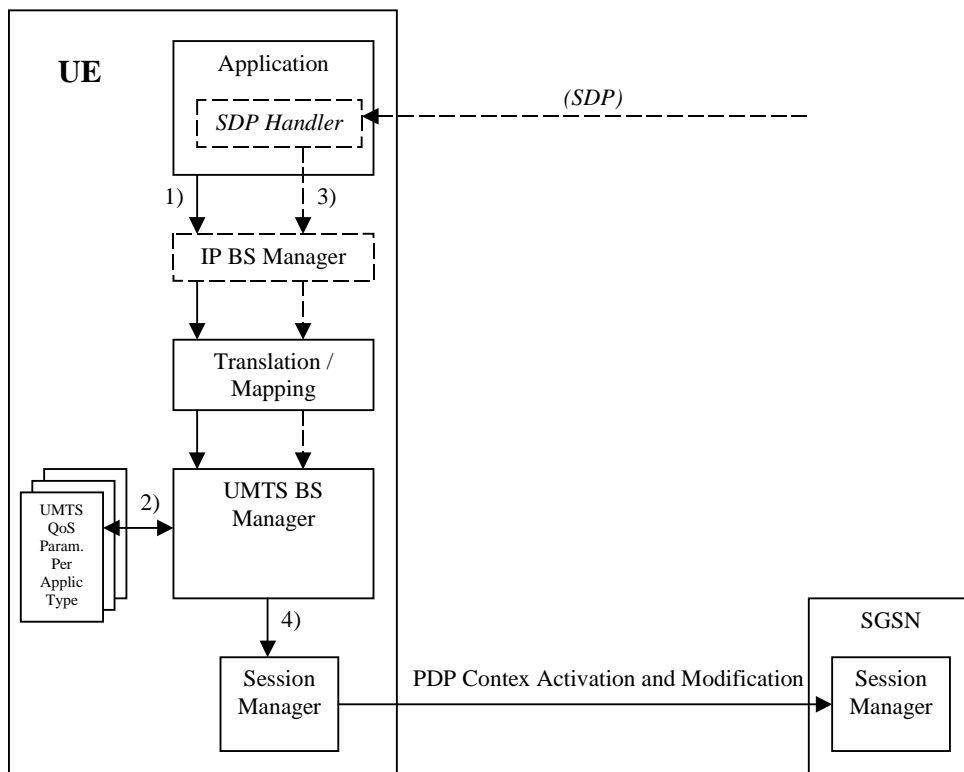

Figure 6.5.1: Framework for generating requested QoS parameters in the UE

6.5.1 SDP to UMTS QoS parameter mapping in UE

If SDP Parameters are available, then before activating or modifying a PDP Context the UE should check if the SDP Parameters give guidance for setting the requested UMTS QoS Parameters. The UE should use the mapping rule in table 6.5.1.1 to derive the Maximum and Guaranteed Bitrate DL/UL from the SDP Parameters.

Table 6.5.1.1: Recommended rules for derivation of the requested Maximum and Guaranteed Bitrate DL/UL per media component in the UE

UMTS QoS Parameter per media component	Derivation from SDP Parameters
Maximum Bitrate DL/UL and Guaranteed Bitrate DL/UL per media component	<pre> /* Check if the media use codec(s) */ IF [(<media> = ("audio" or "video")) and (<transport> = "RTP/AVP")] THEN /* Check if Streaming */ IF a= ("sendonly" or "recvonly") THEN Maximum Bitrate DL/UL and Guaranteed Bitrate DL/UL per media component as specified in reference [6] ; /* Conversational as default !*/ ELSE Maximum Bitrate DL/UL and Guaranteed Bitrate DL/UL per media component as specified in reference [7] ; ENDIF ; /* Check for presence of bandwidth attribute for each media component */ ELSEIF b=AS:<bandwidth-value> is present THEN IF media stream only downlink THEN Maximum Bitrate DL = Guaranteed Bitrate DL =<bandwidth-value >; ELSEIF mediastream only uplink THEN Maximum Bitrate UL = Guaranteed Bitrate UL =<bandwidth-value >; ELSEIF mediastreams both downlink and uplink THEN Maximum Bitrate DL = Guaranteed Bitrate DL =<bandwidth-value >; Maximum Bitrate UL = Guaranteed Bitrate UL =<bandwidth-value >; ENDIF; ELSE /* SDP does not give any guidance ! */ Maximum Bitrate DL/UL and Guaranteed Bitrate DL/UL per media component as specified by the UE manufacturer; ENDIF ; </pre>

6.5.2 SDP parameters to Authorized UMTS QoS parameters mapping in UE

If the PDP Context is activated or modified the UE should use the mapping rules in table 6.5.2.1 for all applications using SDP to derive the Maximum Authorized Bandwidth UL/DL per IP flow or bidirectional combinations of IP flows.

Table 6.5.2.1 also has a mapping rule for derivation of Maximum Authorized Traffic Class per IP flow or bidirectional combinations of IP flows which applies for session initiation and modification.

In future releases this mapping rule may change.

In the case of forking, the various forked responses may have different QoS requirements for the same IP flows of a media component. When the Authorized UMTS QoS Parameters are used by the UE, they shall be set equal to the highest values requested for the IP flows of that media component by any of the active forked responses. The UE should use the mapping rule in table 6.5.2.1 for each forked response.

Table 6.5.2.1: Rules for derivation of the Maximum Authorized Bandwidth DL/UL and the Maximum Authorized Traffic Class per IP flow or bidirectional combination of IP flows in the UE

Authorized UMTS QoS Parameter	Derivation from SDP Parameters (see note 4)
Maximum Authorized Bandwidth DL (Max_BW_DL) and UL (Max_BW_UL) (see NOTE 5)	<pre> IF a=recvonly THEN IF <SDP direction> = mobile originated THEN Direction:= downlink; ELSE /* mobile terminated */ Direction:= uplink; ENDIF; ELSE /* a!= recvonly */ IF a=sendonly THEN IF <SDP direction> = mobile originated THEN Direction:= uplink; ELSE /* mobile terminated */ Direction:= downlink; ENDIF; ELSE /*sendrecv, inactive or no direction attribute*/ Direction:=both; ENDIF; ENDIF; /* Max_BW_UL and Max_BW_DL */ IF media IP flow(s) THEN IF b_{AS}=AS:<bandwidth> is present and (b_{TIAS}=TIAS:<Tbandwidth> is not present or is present but not supported) THEN IF Direction=downlink THEN Max_BW_UL:= 0; Max_BW_DL:= b_{AS}; ELSE IF Direction=uplink THEN Max_BW_UL:= b_{AS}; Max_BW_DL:= 0; ELSE /*Direction=both*/ Max_BW_UL:= b_{AS}; Max_BW_DL:= b_{AS}; ENDIF; ENDIF; ELSE IF b_{TIAS}=TIAS:<Tbandwidth> is present and supported THEN b_{TDBW}= b_{TIAS} + transport-overhead; (NOTE 6) IF Direction=downlink THEN Max_BW_UL:= 0; Max_BW_DL:= b_{TDBW}; (NOTE 6) ELSE IF Direction=uplink THEN Max_BW_UL:= b_{TDBW}; (NOTE 6) Max_BW_DL:= 0; ELSE /*Direction=both*/ Max_BW_UL:= b_{TDBW}; (NOTE 6) Max_BW_DL:= b_{TDBW}; (NOTE 6) ENDIF; ENDIF; ELSE /* b_{TIAS}=TIAS:<Tbandwidth> is NOT present or is present but not supported*/ bw:= as set by the UE manufacturer; IF Direction=downlink THEN Max_BW_UL:= 0; Max_BW_DL:= bw; ELSE IF Direction=uplink THEN </pre>

Authorized UMTS QoS Parameter	Derivation from SDP Parameters (see note 4)
	<pre> Max_BW_UL:= bw; Max_BW_DL:= 0; ELSE /*Direction=both*/ Max_BW_UL:= bw; Max_BW_DL:= bw; ENDIF; ENDIF; ENDIF; ENDIF; ELSE /* RTCP IP flow(s) */ IF b_{RS}=RS:<bandwidth> and b_{RR}=RR:<bandwidth> is present THEN Max_BW_UL:= (b_{RS} + b_{RR}) / 1000; Max_BW_DL:= (b_{RS} + b_{RR}) / 1000; ELSE IF b_{AS}=AS:<bandwidth> is present and (b_{TIAS}=TIAS:<Tbandwidth> is not present or is present but not supported) THEN IF b_{RS}=RS:<bandwidth> is present and b_{RR}=RR:<bandwidth> is not present THEN Max_BW_UL:= MAX[0.05 * b_{AS}, b_{RS} / 1000]; Max_BW_DL:= MAX[0.05 * b_{AS}, b_{RS} / 1000]; ENDIF; IF b_{RS}=RS:<bandwidth> is not present and b_{RR}=RR:<bandwidth> is present THEN Max_BW_UL:= MAX[0.05 * b_{AS}, b_{RR} / 1000]; Max_BW_DL:= MAX[0.05 * b_{AS}, b_{RR} / 1000]; ENDIF; IF b_{RS}=RS:<bandwidth> and b_{RR}=RR:<bandwidth> is not present THEN Max_BW_UL:= 0.05 * b_{AS}; Max_BW_DL:= 0.05 * b_{AS}; ENDIF; ELSE IF b_{TIAS}=TIAS:<Tbandwidth> is present and supported THEN b_{TDBW}= b_{TIAS} + transport-overhead; (NOTE 6) IF b_{RS}=RS:<bandwidth> is present and b_{RR}=RR:<bandwidth> is not present THEN Max_BW_UL:= MAX[0.05 * b_{TDBW}, b_{RS}]/1000; Max_BW_DL:= MAX[0.05 * b_{TDBW}, b_{RS}]/1000; ENDIF; IF b_{RS}=RS:<bandwidth> is not present and b_{RR}=RR:<bandwidth> is present THEN Max_BW_UL:= MAX[0.05 * b_{TDBW}, b_{RR}]/1000; Max_BW_DL:= MAX[0.05 * b_{TDBW}, b_{RR}]/1000; ENDIF; IF b_{RS}=RS:<bandwidth> and b_{RR}=RR:<bandwidth> is not present THEN Max_BW_UL:= 0.05 * b_{TDBW} /1000; Max_BW_DL:= 0.05 * b_{TDBW} /1000; ENDIF; ELSE Max_BW_UL:= as set by the UE manufacture; Max_BW_DL:= as set by the UE manufacture; ENDIF; ENDIF; ENDIF; ENDIF; </pre>

Authorized UMTS QoS Parameter	Derivation from SDP Parameters (see note 4)
Maximum Authorized Traffic Class [MaxTrafficClass] (see NOTE 1, 2 and3)	<pre> IF (all media IP flows of media type "audio" or "video" for the session are unidirectional and have the same direction) THEN MaxService:= streaming; ELSE MaxService:= conversational; ENDIF; CASE <media> OF "audio": MaxTrafficClass:= MaxService; "video": MaxTrafficClass:= MaxService; "application": MaxTrafficClass:=conversational; "data": MaxTrafficClass:=interactive with priority 3; "control": MaxTrafficClass:=interactive with priority 1; /*new media type*/ OTHERWISE: MaxTrafficClass:=background; END;</pre>
<p>NOTE 1: The Maximum Authorized Traffic Class for a RTCP IP flow is the same as for the corresponding RTP media IP flow.</p> <p>NOTE 2: When audio or video IP flow(s) are removed from a session, the parameter MaxService shall keep the originally assigned value.</p> <p>NOTE 3: When audio or video IP flow(s) are added to a session, the UE shall derive the parameter MaxService taking into account the already existing media IP flows within the session.</p> <p>NOTE 4: The SDP parameters are described in RFC 2327 [11].</p> <p>NOTE 5: The 'b=RS:' and 'b=RR:' SDP bandwidth modifiers are defined in RFC 3556 [13].</p> <p>NOTE 6: TIAS is defined in IETF RFC 3890 [23]. RFC 3890 section 6.4 provides procedures for converting TIAS to transport-dependant values. This procedure relies on the presence of maxprate (also defined in RFC 3890).</p>	

The UE should per ongoing session store the Authorized UMTS QoS parameters per IP flow or bidirectional combination of IP flows.

Before activating or modifying a PDP context the UE should check that the requested Guaranteed Bitrate UL/DL (if the Traffic Class is Conversational or Streaming) or the requested Maximum Bitrate UL/DL (if the Traffic Class is Interactive or Background) does not exceed the Maximum Authorized Bandwidth UL/DL per PDP context (calculated according to the rule in table 6.5.2.2). If the requested Guaranteed Bitrate UL/DL or the requested Maximum Bitrate UL/DL exceeds the Maximum Authorized Bandwidth UL/DL per PDP context, the UE should reduce the requested Guaranteed Bitrate UL/DL or the requested Maximum Bitrate UL/DL to the Maximum Authorized Bandwidth UL/DL per PDP context. Furthermore, if the rule in table 6.5.2.1 for calculating Traffic Class per IP flow or bidirectional combination of IP flows is implemented, the UE should check that the requested UMTS QoS parameter Traffic Class does not exceed the Maximum Authorized Traffic Class per PDP context (calculated according to the rule in table 6.5.2.2). If the requested UMTS QoS parameter Traffic Class exceeds the Maximum Authorized Traffic Class per PDP context, the UE should reduce the requested UMTS QoS parameter Traffic Class to the Maximum Authorized Traffic Class per PDP context.

Table 6.5.2.2: Rules for calculating the Maximum Authorized Bandwidths and Maximum Authorized Traffic Class per PDP Context in the UE

Authorized UMTS QoS Parameter per PDP Context	Calculation Rule
Maximum Authorized Bandwidth DL and UL per PDP Context	<p>Maximum Authorized Bandwidth DL/UL per PDP Context is the sum of all Maximum Authorized Bandwidth DL/UL for all the IP flows or bidirectional combinations of IP flows (as derived according to table 6.5.2.1) associated with that PDP Context ;</p> <p>IF Maximum Authorized Bandwidth DL/UL per PDP Context > 256 Mbps THEN Maximum Authorized Bandwidth DL/UL per PDP Context = 256 Mbps /* See ref [4] */ END;</p>
Maximum Authorized Traffic Class per PDP Context	<p>Maximum Authorised Traffic Class per PDP Context = MAX [Maximum Authorized QoS Class per IP flow or bidirectional combination of IP flows (as derived according to table 6.5.2.1) among all the IP flows or bidirectional combinations of IP flows associated with that PDP Context] ;</p> <p>(The MAX function ranks the possible Maximum Authorised Traffic Class values as follows: Conversational > Streaming > Interactive with priority 1 > Interactive with priority 2 > Interactive with priority 3 > Background)</p>

7 PCRF addressing

7.1 General

The PCRF discovery procedures are needed where more than one PCRF is present in an operator's network realm. Within such a deployment, an additional functional element, called DRA, is needed. PCRF discovery procedures include all the procedures that involve a DRA functional element.

Routing of Diameter messages from a network element towards the right Diameter realm in a PLMN is based on standard Diameter realm-based routing, as specified in IETF RFC 3588 [14] using the UE-NAI domain part. If PLMN is separated into multiple realms based on PDN information or IP address range (if applicable); the PDN information available in the Called-Station-Id AVP, or the UE's IPv4 address available in the Framed-IP-Address AVP or the UE's IPv6 address or prefix provided within the Framed-IPv6-Prefix AVP may be used to assist routing PCC message to the appropriate Diameter realm.

The DRA keeps status of the assigned PCRF for a certain UE and IP-CAN session across all reference points, e.g. Gx, Gxx, S9 and Rx interfaces.

The DRA shall support the functionality of a proxy agent and a redirect agent as defined in RFC 3588 [14]. The mode in which it operates (i.e. proxy or redirect) shall be based on operator's requirements.

Diameter clients of the DRA, i.e. AF, PCEF, BBERF and PCRF in roaming scenarios shall support all procedures required to properly interoperate with the DRA in both the proxy and redirect modes.

NOTE: The proxy mode includes two variants:

PA1: Proxy agent based on the standard Diameter proxy agent functionality. All the messages need to go through the DRA.

PA2: Proxy agent based on the standard Diameter proxy agent functionality. Session establishment messages always go through the DRA. Gx, Gxx and S9 session termination messages always go through the DRA. All other messages bypass the DRA.

7.2 DRA Definition

The DRA (Diameter Routing Agent) is a functional element that ensures that all Diameter sessions established over the Gx, S9, Gxx and Rx reference points for a certain IP-CAN session reach the same PCRF when multiple and separately addressable PCRFs have been deployed in a Diameter realm. The DRA is not required in a network that deploys a single PCRF per Diameter realm.

7.3 DRA Procedures

7.3.1 General

A DRA implemented as a Diameter Redirect Agent or a Diameter Proxy Agent shall be compliant to IETF RFC 3588 [14], except when noted otherwise in this document.

7.3.2 DRA Information Storage

The DRA shall maintain PCRF routing information per IP-CAN session or per UE-NAI, depending on the operator's configuration.

The DRA shall select the same PCRF for all the Diameter sessions established for the same UE in case 2a.

The DRA shall select the same PCRF per S9 session for the same UE.

The DRA has information about the user identity (UE NAI), the UE IPv4 address and/or IPv6 prefix, the APN(if available)and the selected PCRF address for a certain IP-CAN Session .

The PCRF routing information stored for an IP-CAN session in the DRA shall be removed after the IP-CAN session is terminated. In case of DRA change (e.g. inter-operator handover), the information about the IP-CAN session stored in the old DRA shall be removed.

The PCRF routing information stored per UE in the DRA may be removed when no more IP-CAN and gateway control sessions are active for the UE.

7.3.3 Capabilities Exchange

In addition to the capabilities exchange procedures defined in IETF RFC 3588 [14], the Redirect DRA and Proxy DRA shall advertise the specific applications it supports (e.g., Gx, Gxx, Rx or S9) by including the value of the application identifier in the Auth-Application-Id AVP and the value of the 3GPP (10415) in the Vendor-Id AVP of the Vendor-Specific-Application-Id AVP contained in the Capabilities-Exchange-Request and Capabilities-Exchange-Answer commands.

7.3.4 Redirect DRA

7.3.4.1 Redirecting Diameter Requests

A DRA implemented as a Diameter redirect agent shall redirect the received Diameter request message by carrying out the procedures defined in section 6.1.7 of IETF RFC 3588 [14]. The Client shall use the value within the Redirect-Host AVP of the redirect response in order to obtain the PCRF identity. The DRA may provide the Redirect-Host-Usage AVP in the redirect response to provide a hint to the Client about how the cached route table entry created from the Redirect-Host AVP is to be used as described in section 6.13 of IETF RFC 3588 [14].

The two most relevant redirect host usage scenarios for PCC from IETF RFC 3588 [14] are:

- If the PCRF routing information is per UE-NAI, the DRA shall set the Redirect-Host-Usage AVP to ALL_USER. The DRA client may contact the DRA on IP-CAN session termination.
- If the PCRF routing information is per IP-CAN session, the DRA shall set the Redirect-Host-Usage AVP to ALL_SESSION. The DRA client shall contact the DRA on IP-CAN session termination.

The DRA may also provide the Redirect-Max-Cache-Time AVP in the redirect response to indicate to the Client the lifetime of the cached route table entry created from the Redirect-Host and Redirect-Host-Usage AVP values as described in section 6.14 of IETF RFC 3588 [14].

If the DRA is maintaining PCRF routing information per IP-CAN session, the DRA shall be aware of Gx and Gxx Diameter termination requests as defined in 3GPP TS 29.212 [9] in order to detect whether release of DRA bindings is required. Otherwise the DRA clients shall use cached route table entry created from the Redirect-Host, Redirect-Host-Usage and Redirect-Max-Cache-Time AVPs to determine whether DRA interaction is required.

The DRA shall be aware of IP-CAN Session modification requests over Gx which is to update the IPv4 address of the UE by the PCEF.

If the client is the AF, the DRA (redirect) does not need not to maintain Diameter sessions and Diameter Base redirect procedures are applicable. Therefore, an AF should not send an AF session termination request to the DRA

7.3.4.2 DRA binding removal

If the DRA binding is per IP-CAN session and the IP-CAN session is terminated or if the DRA binding is per UE and the last IP-CAN session is terminated (eg. from an indication by the BBERF/PCEF) the Redirect DRA shall remove the associated DRA binding information and responds with a Diameter redirect answer message.

7.3.5 Proxy DRA

The DRA shall support the functionality of a Diameter proxy agent as defined in RFC 3588 [14].

When the DRA receives a request from a client, it shall check whether it already has selected a PCRF for the UE or the UE's IP-CAN session; if it does have a PCRF already selected for that UE or UE's IP-CAN session, it shall proxy the request to the corresponding PCRF. If the request is an IP-CAN session termination or gateway control session

termination, the DRA shall check whether PCRF routing information shall be removed as specified in section 7.3.3. If the DRA does not have a PCRF already selected, it shall follow one of the procedures below:

- If the request is an IP-CAN session establishment or gateway control session establishment, it shall select a PCRF to handle all sessions for that UE or UE's IP-CAN session. It shall then proxy the request to the selected PCRF.
- Otherwise, if the request is not an IP-CAN session establishment or gateway control session establishment, it shall reject the request.

Editor's note: It is FFS which error code is returned in this failure case. Either a Diameter routing error code such as `DIAMETER_UNABLE_TO_DELIVER` or the DRA may follow the procedures for the corresponding application and reject with the appropriate code (e.g. `IP_CAN_SESSION_NOT_AVAILABLE` for an Rx request).

If a DRA is deployed in a PCRF's realm, clients of the DRA shall send the first request of a session to the DRA handling the PCRF's realm. Clients of the DRA shall as well send IP-CAN session termination and gateway control termination requests to the DRA. A client of the DRA shall be capable of sending every message of a session to the DRA. A client of the DRA may be configured to bypass the DRA on session modification messages and AF session termination messages by sending these types of messages directly to the PCRF.

7.3.6 PCRF selection by BBERF/PCEF (non-roaming case)

The PCEF (e.g. P-GW) or BBERF (e.g. Non-3GPP Access, S-GW) shall provide the DRA of the PCRF realm with identity parameters upon the first interaction between the access entity and the PCRF realm.

If the redirect agent is used for DRA, the DRA shall use the redirecting requests procedure as specified in IETF RFC 3588 [14], and include the PCRF address (Diameter Identity) in the Redirect-Host AVP in the Diameter reply sent to the PCEF or the BBERF.

If proxy agent is used for DRA, the DRA should use the proxy procedure as specified in IETF RFC 3588 [14]. For PA2 solution (described in clause 7.1), only session establishment, session modification with the UE's IPv4 address updated and session termination messages shall be sent through the DRA.

The identity parameters from the PCEF or BBERF may comprise the UE's IPv4 address in the Framed-IP-Address AVP, and/or the UE's IPv6 prefix in the Framed-IPv6-Prefix AVP, PDN information in the Called-Station-Id AVP and user identity in the Subscription-Id AVP.

7.3.7 PCRF selection by AF

If the AF has the realm identification (i.e. FQDN from a UE NAI) and is located in the H-PLMN, the AF sends the user identity in the Subscription-Id AVP and PDN information (i.e. APN) if available in the Called-Station-Id AVP in a Diameter request to the DRA which acts as a Diameter agent.

If the AF does not have proper knowledge about the user identity and the AF is located in the HPLMN, the AF may use pre-configured information to find the DRA.

Editor's Note: It is FFS how the AF (e.g. a third party or non-IMS application server) finds the DRA if it does not have the proper knowledge about the user identity. It is FFS whether a pre-configured destination realm will suffice in these cases.

The AF shall provide the DRA of the PCRF realm with identity parameters upon the first interaction between the AF and the PCRF realm.

If redirect agent is used for DRA, the DRA shall use the redirecting requests procedure as specified in IETF RFC 3588 [14], and include the PCRF address (Diameter Identity) in the Redirect-Host AVP in the Diameter reply sent to the AF.

If proxy agent is used for DRA, the DRA should use the proxy procedure as specified in IETF RFC 3588 [14]. For PA2 solution (described in clause 7.1), only AF session establishment messages shall be sent through the DRA.

The parameters from the AF may comprise the UE IP address in either the Framed-IP-Address AVP or the Framed-IPv6-Prefix AVP, PDN information in the Called-Station-Id AVP and user identity in the Subscription-Id AVP (3GPP TS 23.203 [2]).

7.3.8 PCRF selection in a roaming scenario

In the roaming case, a V-DRA is needed in the visited PLMN when there are more than one PCRFs per realm. The V-DRA will ensure that all the related Diameter sessions for a UE are handled by the same V-PCRF.

The BBERF in the visited access and home routed cases, the PCEF in the case of visited access and the AF when located in the visited PLMN may use pre-configured information (e.g. based on PDN) to find the V-DRA, and then find the V-PCRF. Other possible options are Dynamic peer discovery, or DNS-based.

The V-PCRF can find the H-DRA based on the UE NAI, and then find the H-PCRF by the H-DRA.

The V-PCRF shall provide the H-DRA of the H-PCRF realm with identity parameters upon the first interaction between the V-PCRF and the H-PCRF realm.

If redirect agent is used for H-DRA, the H-DRA shall use the redirecting requests procedure as specified in IETF RFC 3588 [14], and include the H-PCRF address (Diameter Identity) in the Redirect-Host AVP in the Diameter reply sent to the V-PCRF.

If proxy agent is used for H-DRA, the H-DRA should use the proxy procedure as specified in IETF RFC 3588 [14]. For PA2 solution (described in clause 7.1), only session establishment, session modification with the UE's IPv4 address updated and termination messages shall be sent through the H-DRA.

The identity parameters from the V-PCRF may comprise the same parameters sent by the PCEF or the BBERF to the V-PCRF, i.e. the user identity (UE NAI), APN, the UE's IPv4 address and/or IPv6 prefix (3GPP TS 23.203 [2]).

If redirect agent or PA2 is used for H-DRA, and the V-PCRF receives establishment message from the AF in the VPLMN, the V-PCRF may send the message to the H-PCRF directly (e.g. based on the stored information provided by H-DRA during the IP-CAN session establishment).

7.4 DRA flows

7.4.1 Proxy DRA

7.4.1.1 Establishment of Diameter Sessions

7.4.1.1.1 Non-roaming cases

Establishment of Diameter sessions may occur at any of the following cases:

- Gateway control establishment
- IP-CAN session establishment
- AF session establishment

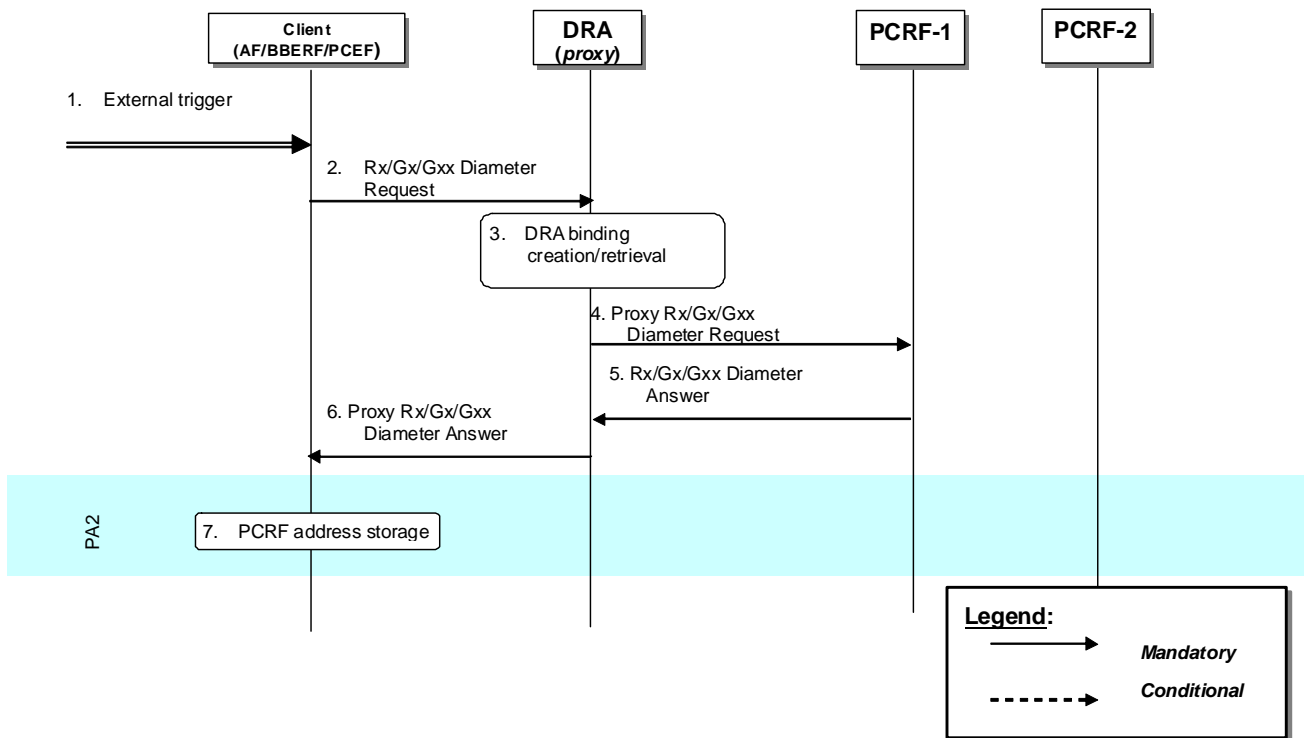

Figure 7.4.1.1.1.1: Establishment of Diameter sessions using DRA (proxy)

1. A Client receives an external trigger (e.g. IP-CAN session establishment request) that requires the establishment of a Diameter session with a PCRF.
2. A Diameter Request (e.g. a Diameter CCR sent by PGW to indicate establishment of an IP-CAN session as defined in clauses 4.5.1, 4a.5.1 of 3GPP TS 29.212 [9]) is sent by the Client and received by a DRA (proxy).
3. The DRA (proxy) stores the user information (e.g. UE-NAI) and checks whether an active DRA binding exists. If not, the DRA creates a dynamic DRA binding (assignment of a PCRF node per UE or per IP-CAN session).

NOTE: When the AF establishes an Rx session with the DRA, there is already a DRA binding active

4. The DRA (proxy) proxies the Diameter Request to the target PCRF. The proxied Diameter Request maintains the same Session-Id AVP value.
5. PCRF-1 returns a Diameter Answer as defined in clauses 4.5, 4a.5 of 3GPP TS 29.212 [9] to the DRA (proxy).
6. DRA (proxy) proxies the Diameter Answer to the Client. The proxied Diameter Answer maintains the same Session-Id AVP value.
7. If PA2 option is implemented, the Client uses the Origin-Host AVP value provided in the Diameter Answer of step 6. This value is the identity of the target PCRF. The client populates the Destination-Host AVP with this address and sends any subsequent Diameter messages directly to this PCRF bypassing the DRA (proxy).

NOTE: Figure 7.4.1.1.1.1 is also applicable when the AF/BBERF/PCEF in the VPLMN contacts the V-DRA to locate the V-PCRF.

7.4.1.1.2 Roaming cases

Establishment of Diameter sessions may occur at any of the following cases:

- V-PCRF initiates S9 Diameter session to H-PCRF
- V-PCRF proxies Rx Diameter session to H-PCRF

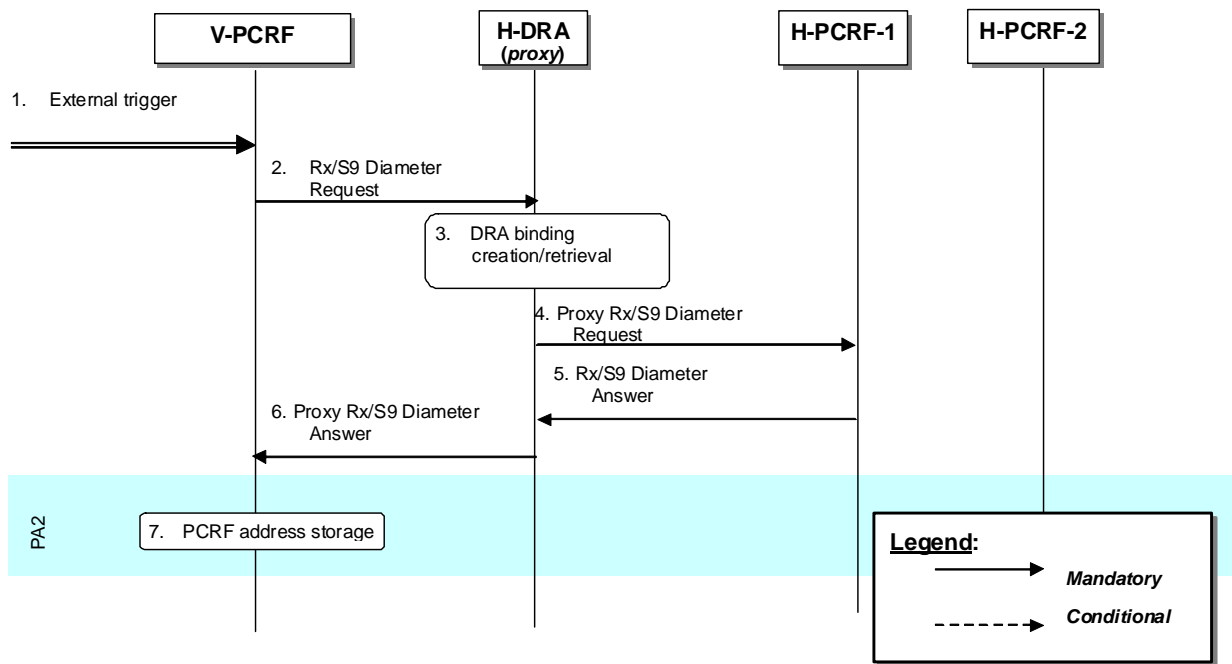

Figure 7.4.1.1.2.1: Establishment of Diameter sessions using DRA (proxy) – Roaming case

1. V-PCRF receives a trigger to establish a Diameter session to H-PCRF (e.g. S9 session establishment request).
2. A Diameter Request involving either the Rx or S9 protocol is sent by the V-PCRF and received by a H-DRA (proxy) in the home PLMN.
3. The H-DRA (proxy) stores the user information (e.g. UE-NAI) and checks whether an active DRA binding exists. If not, the H-DRA creates a dynamic DRA binding (assignment of a PCRF node per UE or per IP-CAN session).
4. The H-DRA (proxy) proxies the Diameter Request to the target PCRF in the home PLMN. The proxied Diameter Request maintains the same Session-Id AVP value.
5. H-PCRF-1 returns a Diameter Answer to the H-DRA (proxy).
6. H-DRA (proxy) proxies the Diameter Answer to the V-PCRF. The proxied Diameter Answer maintains the same Session-Id AVP value.
7. If PA2 option is implemented, the V-PCRF uses the Origin-Host AVP value provided in the Diameter Answer of step 6. This value is the identity of the target H-PCRF. The V-PCRF populates the Destination-Host AVP with this address and sends any subsequent Diameter messages directly to this H-PCRF bypassing the H-DRA

7.4.1.2 Modification of Diameter Sessions

7.4.1.2.1 Non-roaming cases

7.4.1.2.1.1 Client-initiated

Modification of Diameter sessions may occur in any of the following cases:

- Gateway control session modification
- IP-CAN session modification
- AF session modification

If PA1 option is implemented, only steps 2, 3, 4, 5, 6 are carried out. If PA2 option is implemented, only steps 2a, 5a are carried out.

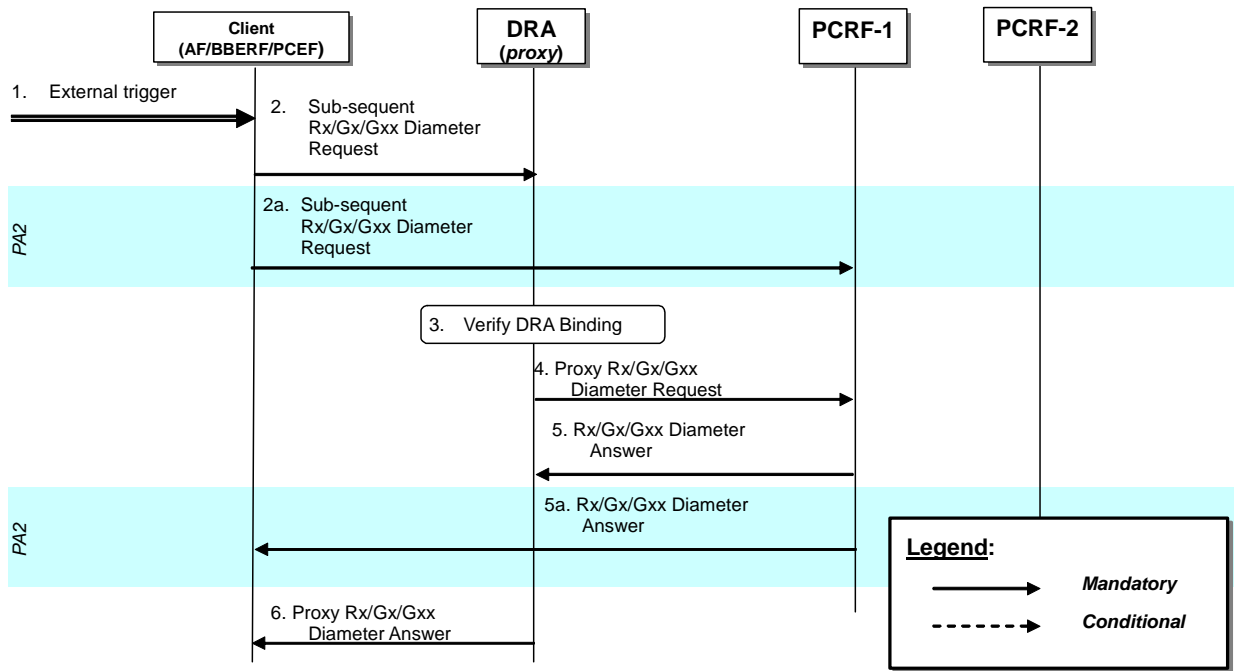

Figure 7.4.1.2.1.1.1: Modification of Diameter sessions through DRA (proxy)- AF/BBERF/PCEF interaction

1. A Client receives an external trigger (e.g. IP-CAN session modification) that requires a subsequent Diameter message to be sent to the PCRF.
2. A subsequent Diameter Request (e.g. a Diameter CCR sent by PGW to indicate modification of an IP-CAN session) as defined in clauses 4.5.1, 4a.5.1 of 3GPP TS 29.212 [9] or clause 4.4 of 3GPP TS 29.214 [10]) is sent by the Client and received by the DRA (proxy).
- 2a If PA2 option is implemented, based on Client configuration and operator policy, the Client communicates directly to the PCRF, bypassing the DRA (proxy), by using the PCRF identity obtained through the Origin-Host AVP (see step 7 in clause 5.2.5.7.1.1). The Client uses the same active Session-Id AVP value on the Diameter Request sent to the PCRF. In such a case steps 2, 3, 4, 5, 6 are not carried out.
3. After receiving a Diameter Request (Step 2), the DRA (proxy) verifies that there is an active DRA binding for the session identified in the request.
4. The DRA (proxy) proxies the Diameter Request to the target PCRF.
5. PCRF-1 returns a Diameter Answer as defined in clauses 4.5, 4a.5 of 3GPP TS 29.212 [9] or clause 4.4 of 3GPP TS 29.214 [10]) to the DRA (proxy).
- 5a Upon receiving a Diameter Request (Step 2a), PCRF-1 returns a Diameter Answer directly to the Client, bypassing the DRA (proxy).
6. DRA (proxy) proxies the Diameter Answer to the Client.

NOTE: Figure 7.4.1.2.1.1.1 is also applicable when the AF/BBERF/PCEF in the VPLMN modifies the Diameter session through the V-DRA.

7.4.1.2.1.2 PCRF-initiated

Modification of Diameter sessions occur on PCRF initiated session modifications towards the clients (AF/BBERF/PCEF).

If PA1 option is implemented, only steps 2, 3, 4, 5, 6 are carried out. If PA2 option is implemented, only steps 2a, 5a are carried out.

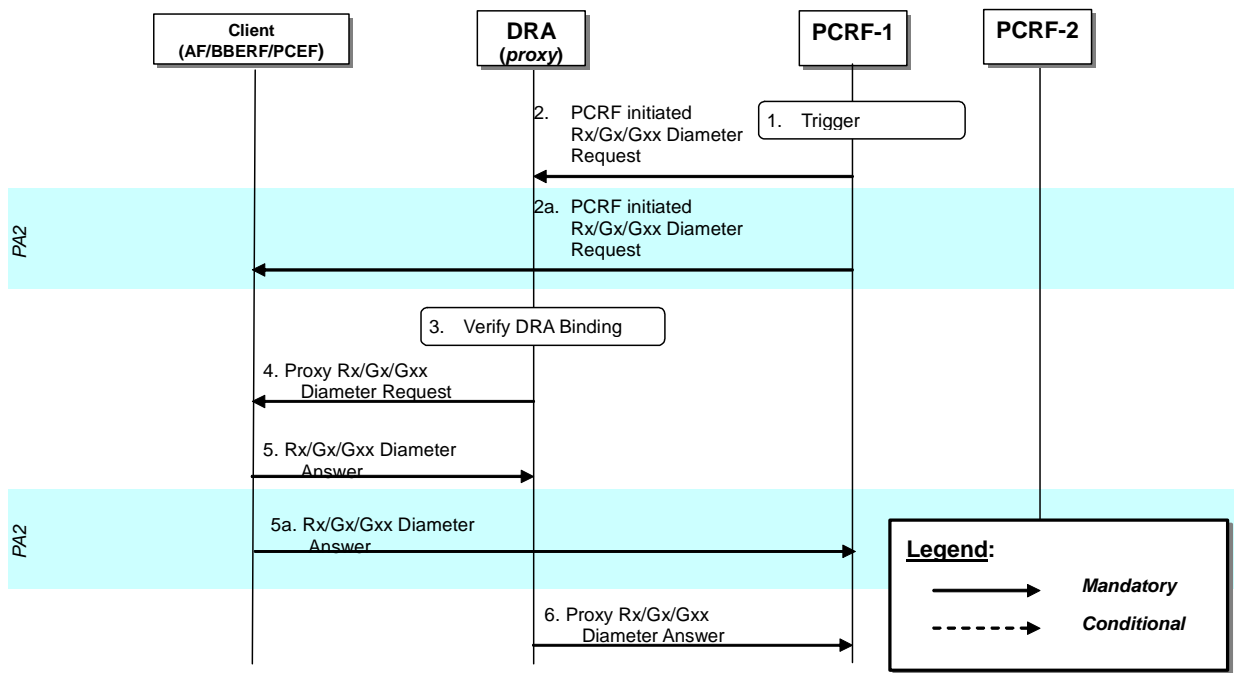

Figure 7.4.1.2.1.2.1: Modification of Diameter sessions through DRA (proxy)- PCRF interaction

1. PCRF receives an internal or external trigger that requires a Diameter message to be sent to the clients (either AF, BBERF, PCEF)
2. A PCRF-initiated Diameter Request (e.g. a Diameter RAR request sent to the PGW) is sent to the Clients and received by the DRA (proxy).
- 2a If PA2 option is implemented, the PCRF communicates directly to the client, bypassing the DRA (proxy). In such a case steps 2, 3, 4, 5, 6 are not carried out.
3. After receiving a Diameter Request (Step 2), the DRA (proxy) verifies that there is an active DRA binding for the session identified in the request.
4. The DRA (proxy) proxies the Diameter Request to the Client. The proxied Diameter Request maintains the same Session-Id AVP value.
5. Clients returns a Diameter Answer as defined in clauses 4.5, 4a.5 of 3GPP TS 29.212 [9] or clause 4.4 of 3GPP TS 29.214 [10]) to the DRA (proxy).
- 5a Upon receiving a Diameter Request (Step 2a), Client returns a Diameter Answer directly to the PCRF, bypassing the DRA (proxy).
6. DRA (proxy) proxies the Diameter Answer to the PCRF.

NOTE: Figure 7.4.1.2.1.2.1 is also applicable when the V-PCRF modifies the Diameter session through the V-DRA.

7.4.1.2.2 Roaming cases

7.4.1.2.2.1 V-PCRF initiated

In roaming scenarios modification of Diameter sessions may occur at any of the following cases:

- V-PCRF S9 Diameter session modification to H-PCRF
- V-PCRF proxies Rx Diameter session modification to H-PCRF

If PA1 option is implemented, only steps 2, 3, 4, 5, 6 are carried out. If PA2 option is implemented, only steps 2a, 5a are carried out.

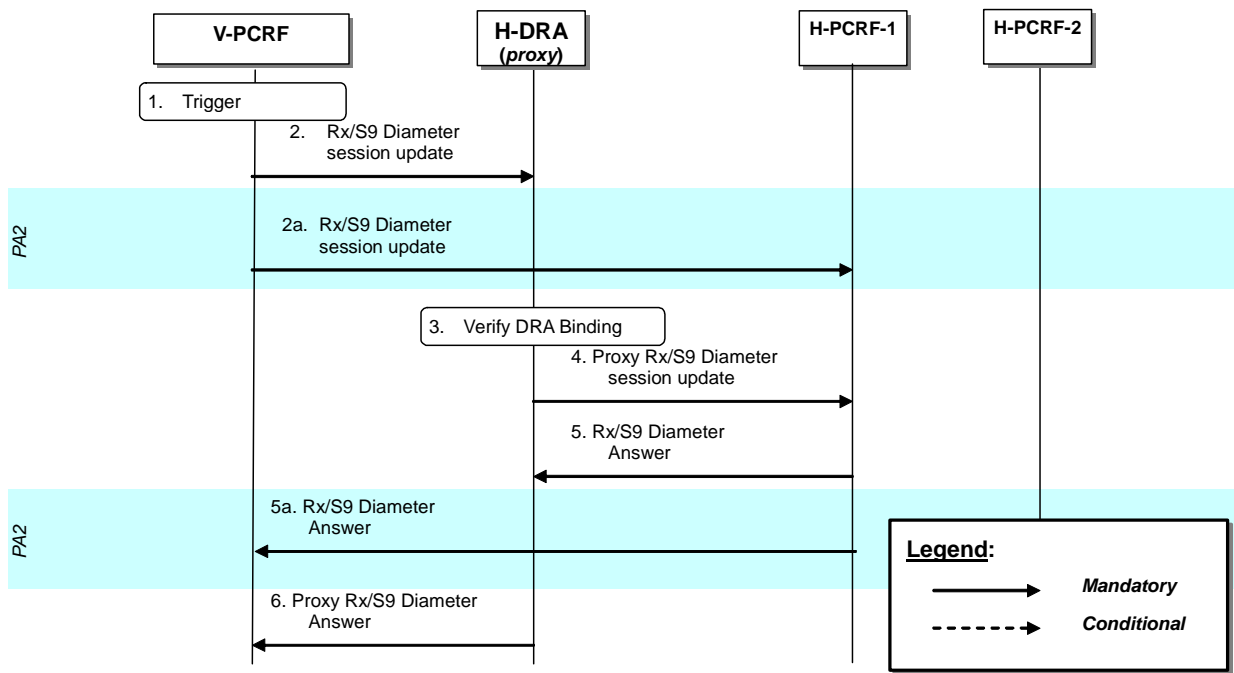

Figure 7.4.1.2.2.1.1: Modification of Diameter sessions through DRA (proxy) on roaming scenarios – V-PCRF initiated

1. V-PCRF receives an internal or external trigger that requires a Diameter message to be sent to H-PCRF over the S9 reference point
2. V-PCRF sends a Diameter session update (e.g. an S9 session modification request) over the S9 reference point that is received by the DRA (proxy) in the home PLMN.
- 2a If PA2 option is implemented, the V-PCRF communicates directly to the H-PCRF, bypassing the H-DRA (proxy). In such a case steps 2, 3, 4, 5, 6 are not carried out.
3. After receiving a Diameter Request (Step 2), the H-DRA (proxy) verifies that there is an active DRA binding for the session identified in the request.
4. The H-DRA (proxy) proxies the Diameter Request to the H-PCRF. The proxied Diameter Request maintains the same Session-Id AVP value.
5. H-PCRF returns a Diameter Answer to the H-DRA (proxy) in the home PLMN.
- 5a Upon receiving a Diameter Request (Step 2a), Client returns a Diameter Answer directly to the PCRF, bypassing the H-DRA (proxy).
6. H-DRA (proxy) proxies the Diameter Answer to the PCRF.

7.4.1.2.2.2 H-PCRF initiated

In roaming scenarios modification of Diameter sessions may occur at any of the following cases:

- H-PCRF S9 Diameter session modification to V-PCRF

If PA1 option is implemented, only steps 2, 3, 4, 5, 6 are carried out. If PA2 option is implemented, only steps 2a, 5a are carried out.

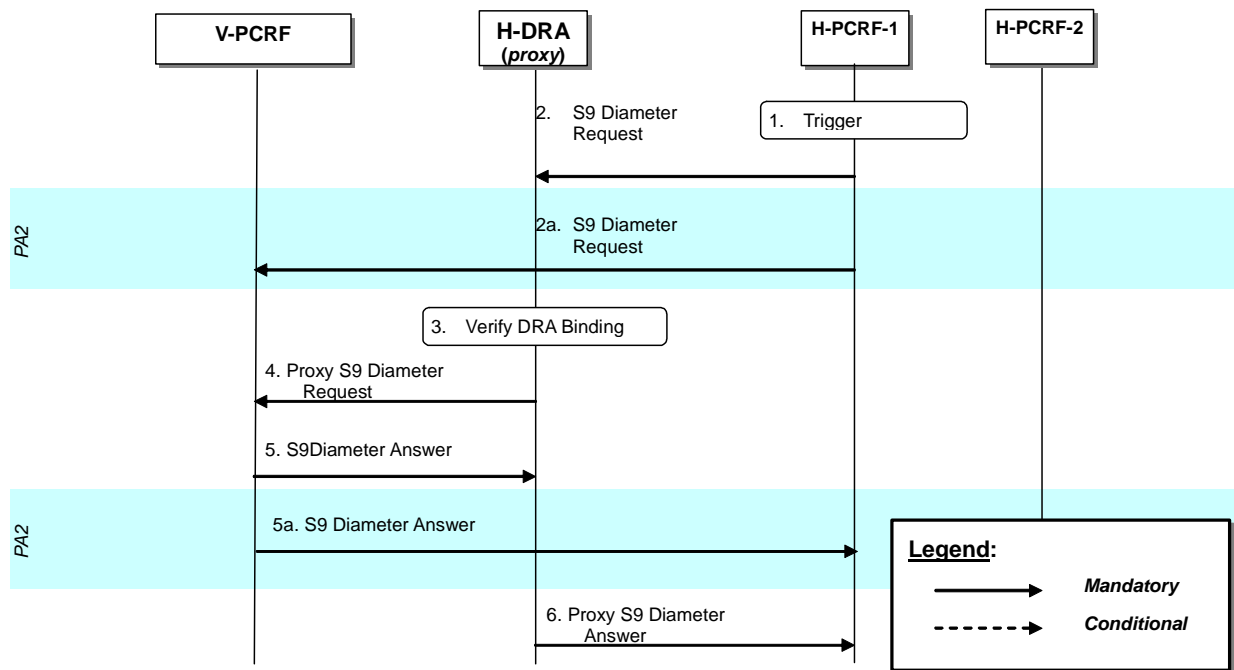

Figure 7.4.1.2.2.1: Modification of Diameter sessions through DRA (proxy) on roaming scenarios – H-PCRF initiated

1. H-PCRF receives an internal or external trigger that requires a Diameter message to be sent to V-PCRF over the S9 reference point.
2. H-PCRF sends a Diameter session update (e.g. an S9 session modification request) over the S9 reference point that is received by the H-DRA (proxy) in the home PLMN.
- 2a If PA2 option is implemented, the H-PCRF communicates directly to the V-PCRF, bypassing the H-DRA (proxy). In such a case steps 2, 3, 4, 5, 6 are not carried out.
3. After receiving a Diameter Request (Step 2), the H-DRA (proxy) verifies that there is an active DRA binding for the session identified in the request.
4. The H-DRA (proxy) proxies the Diameter Request to the V-PCRF. The proxied Diameter Request maintains the same Session-Id AVP value.
5. V-PCRF returns a Diameter Answer to the H-DRA (proxy) in the home PLMN.
- 5a Upon receiving a Diameter Request (Step 2a), V-PCRF returns a Diameter Answer directly to the H-PCRF, bypassing the H-DRA (proxy).
6. H-DRA (proxy) proxies the Diameter Answer to the H-PCRF.

7.4.1.3 Termination of Diameter Sessions

7.4.1.3.1 Non-roaming cases

The procedures required are identical for both PA1 and PA2 options

Termination of Diameter sessions occur at the following cases:

- Gateway control session termination
- IP-CAN session termination
- AF session termination

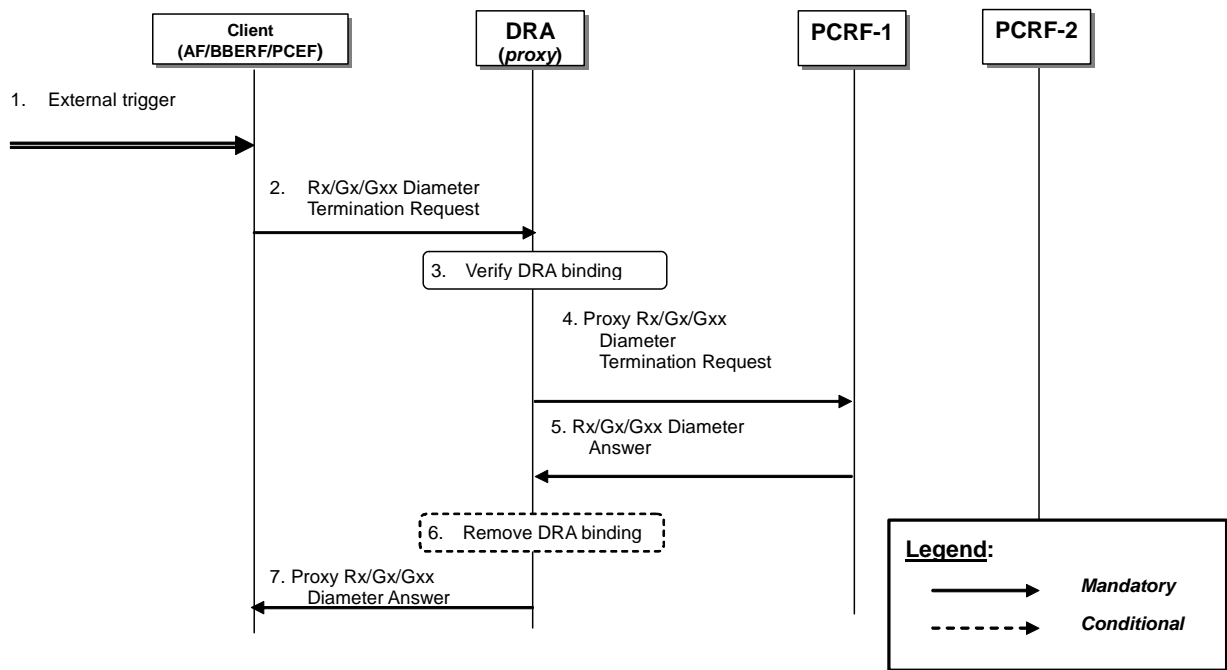

Figure 7.4.1.3.1.1: Termination of Diameter sessions through DRA (proxy)

1. A Client receives an external trigger (e.g. an IP-CAN session termination is initiated by the UE or PCRF) that requires the sending of a Diameter Termination Request.
2. A Diameter Termination Request (e.g., a Diameter CCR sent by PGW to indicate termination of an IP-CAN session) as defined in clauses 4.5, 4a.5 of 3GPP TS 29.212 [9]) is sent by the Client to the DRA (proxy). The message uses the same Session-Id AVP value of the active Diameter session established between the Client and PCRF-1.
3. The DRA (proxy) verifies that there is an active DRA binding for the IP-CAN session based on the Session-Id AVP in the request.
4. The DRA (proxy) proxies the Diameter Termination Request to the target PCRF. The proxied Diameter Request maintains the same Session-Id AVP value.
5. PCRF-1 acknowledges termination of the session. PCRF-1 sends a Diameter Answer, (e.g., as defined in clauses 4.5, 4a.5 of 3GPP TS 29.212 [9]) to DRA (proxy).
6. The DRA marks the Diameter session terminated. If the DRA binding is per IP-CAN session and all the Diameter sessions (i.e. the Gx session or the Gxx session) of the IP-CAN session are terminated or if the DRA binding is per UE and all the Diameter sessions (i.e. the Gx session or the Gxx session) of that UE are terminated the DRA (proxy) removes the DRA binding.
7. DRA (proxy) proxies the Diameter Answer to the Client. The proxied Diameter Answer maintains the same Session-Id AVP value.

NOTE: Figure 7.4.1.3.1.1 is also applicable when the AF/BBBERF/PCEF in the VPLMN terminates the Diameter sessions through the V-DRA.

NOTE: AF is not required to send Diameter session termination request to DRA (PA2).

7.4.1.3.2 Roaming cases

In roaming cases (over S9 reference point) termination of Diameter sessions occur at the following cases:

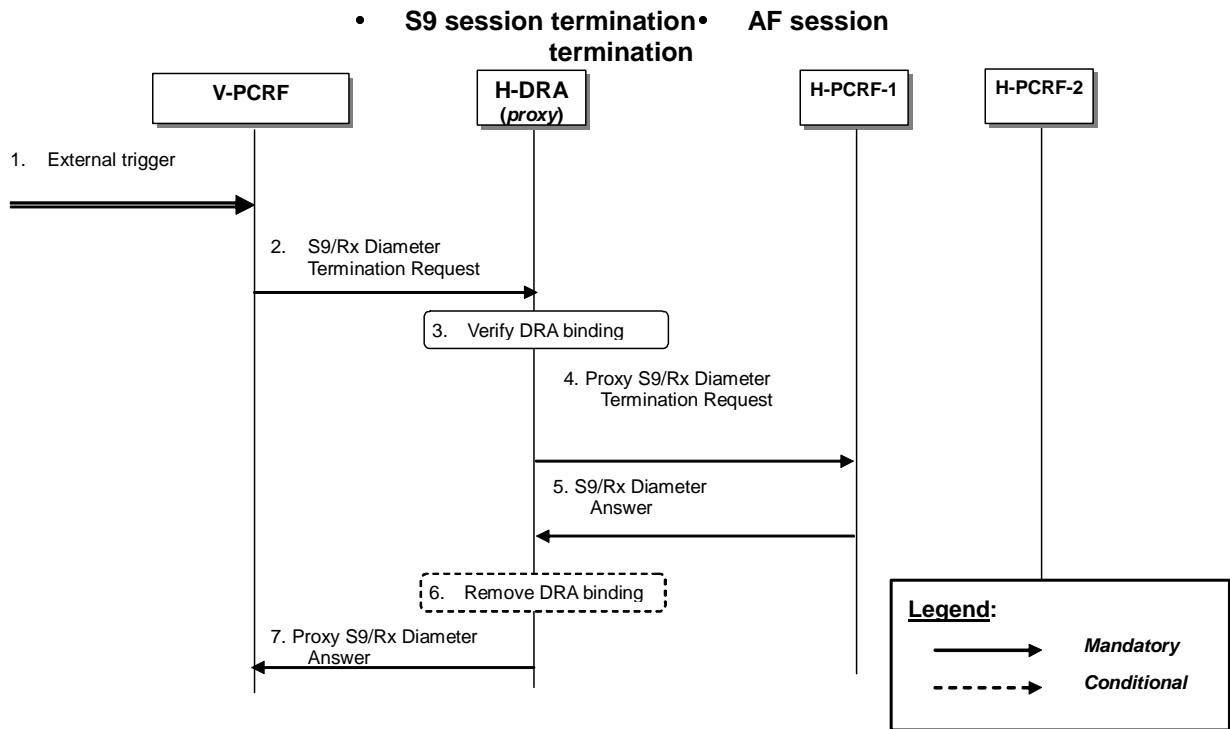

Figure 7.4.1.3.2.1: Termination of Diameter sessions through H-DRA (proxy) – Roaming cases

1. The V-PCRF receives an external trigger (e.g., session termination request from the BBERF or the PCEF) that requires the sending of a Diameter Termination Request.
2. A Diameter Termination Request (e.g., an S9 termination request) is sent by the V-PCRF and received by the H-DRA (proxy) in the home PLMN. The message uses the same Session-Id AVP value of the active Diameter session established between V-PCRF and H-PCRF-1.
3. The H-DRA (proxy) verifies that there is an active DRA binding for the IP-CAN session based on the Session-Id AVP in the request.
4. The H-DRA (proxy) proxies the Diameter Termination Request to the target H-PCRF-1. The proxied Diameter Request maintains the same Session-Id AVP value.
5. H-PCRF-1 acknowledges termination of the session. H-PCRF-1 sends a Diameter Answer to H-DRA (proxy) in the home PLMN.
6. The H-DRA marks the Diameter session terminated. If all the Diameter sessions (i.e. the S9 session, the Gxx session, and the Gx session) of that UE are terminated the H-DRA (proxy) removes the DRA binding.
7. H-DRA (proxy) proxies the Diameter Answer to the V-PCRF. The proxied Diameter Answer maintains the same Session-Id AVP value.

NOTE: V-PCRF does not need to send Rx Diameter termination messages to proxy H-DRA (PA2 option) since Rx Diameter termination messages do not affect the DRA binding.

7.4.2 Redirect DRA

7.4.2.1 Establishment of Diameter Sessions

7.4.2.1.1 Non-roaming cases

Establishment of Diameter sessions may occur at the following cases:

- Gateway control session establishment
- IP-CAN session establishment

- AF session establishment

The DRA client (AF/BBBERF/PCEF) shall follow the procedure below if an appropriate cached route table entry created from previous DRA (redirect) interactions does not exist. Cached route table entries are created from the Redirect-Host, Redirect-Host-Usage and Redirect-Max-Cache-Time AVPs as described in sections 6.12, 6.13 and 6.14 of IETF RFC 3588 [14].

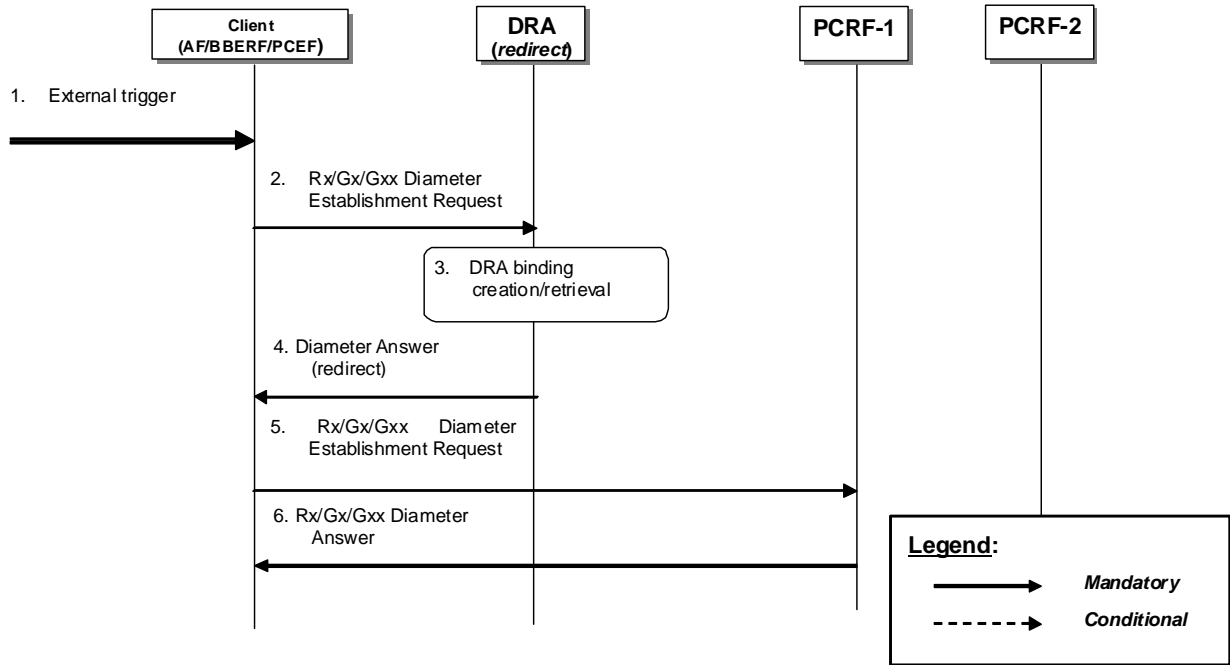

Figure 7.4.2.1.1.1: Establishment of Diameter session through DRA (redirect)

1. A Client receives an external trigger (e.g., IP-CAN session establishment request) that requires the establishment of a Diameter session with a PCRF.
2. A Diameter Establishment request (e.g., a Diameter CCR sent by PGW to indicate establishment of an IP-CAN session as defined in clauses 4.5.1, 4a.5.1 of 3GPP TS 29.212 [9]) with user information (e.g., UE-NAI) is sent by the Client and received by the DRA (redirect).
3. The DRA (redirect) stores the user information (e.g., UE-NAI) and checks whether an active DRA binding exists. If not the DRA creates a dynamic DRA binding (assignment of a PCRF node per UE or per IP-CAN session); if the DRA (redirect) find there has been a DRA binding for the user, the DRA shall select the PCRF from the binding for the client.
4. The DRA (redirect) sends a Diameter Answer indicating redirection as defined in IETF RFC 3588 [14]. The target PCRF identity is included in the Redirect-Host AVP.
5. The Client re-sends the Diameter Establishment Request of step 2 to the target PCRF.
6. PCRF-1 returns a Diameter Answer, as defined in clauses 4.5, 4a.5 of 3GPP TS 29.212 [12], to the Client.

NOTE: Figure 7.4.2.1.1.1 is also applicable when the AF/BBBERF/PCEF in the VPLMN contacts the V-DRA to locate the V-PCRF.

7.4.2.1.2 Roaming cases

Establishment of Diameter sessions may occur at the following cases:

- S9 session establishment
- AF session establishment

The DRA client (AF/BBBERF/PCEF) shall follow the procedure below if an appropriate cached route table entry created from previous DRA (redirect) interactions does not exist. Cached route table entries are created from the Redirect-Host,

Redirect-Host-Usage and Redirect-Max-Cache-Time AVPs as described in section 6.12, 6.13 and 6.14 of IETF RFC 3588 [14].

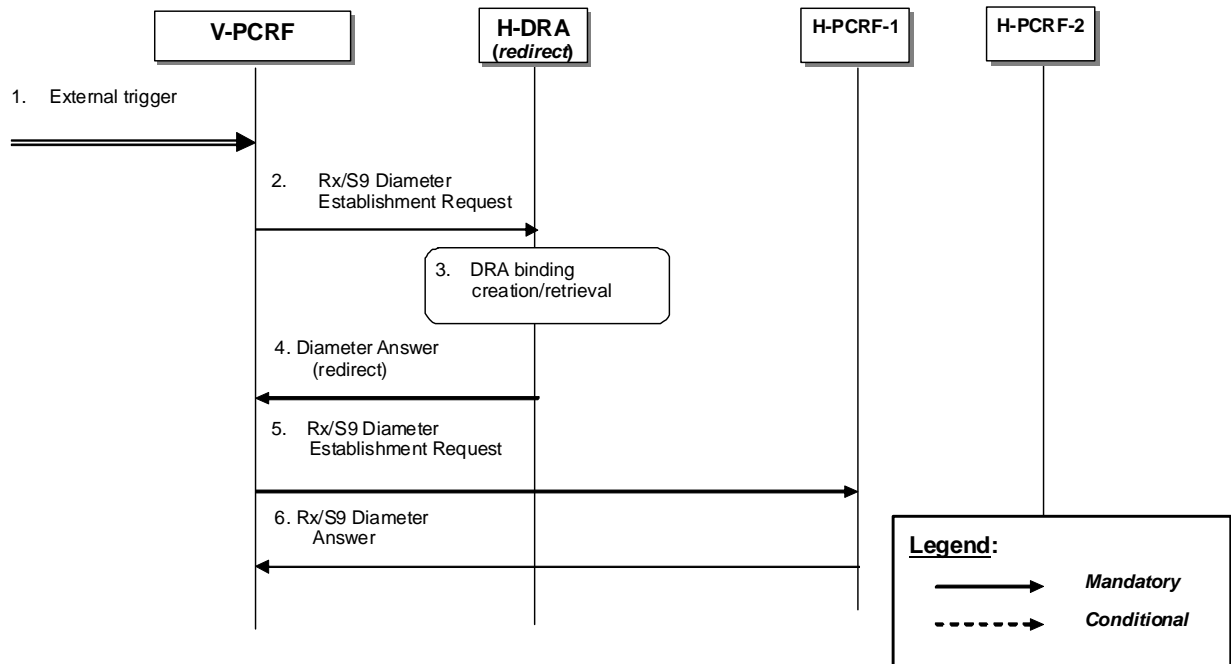

Figure 7.4.2.1.2.1: Establishment of Diameter session through DRA (redirect) – Roaming scenario

1. The V-PCRF receives an external trigger (e.g., IP-CAN session establishment request) that requires the establishment of a Diameter session with an H-PCRF over the S9 reference point.
2. A Rx/S9 Diameter Establishment Request with user information (e.g., UE-NAI) is sent by the V-PCRF and received by the H-DRA (redirect) in the home PLMN.
3. The H-DRA (redirect) stores the user information (e.g., UE-NAI) and checks whether an active DRA binding exists. If not the H-DRA creates a dynamic DRA binding (assignment of a PCRF node per UE); if the DRA (redirect) find there has been a DRA binding for the user, the DRA shall select the PCRF from the binding for the client.
4. The H-DRA (redirect) sends a Diameter Answer indicating redirection as defined in IETF RFC 3588 [14]. The target PCRF identity is included in the Redirect-Host AVP.
5. The V-PCRF re-sends the Rx/S9 Diameter Establishment Request of step 2 to the target H-PCRF.
6. H-PCRF-1 returns a corresponding Diameter Answer to the V-PCRF.

NOTE: The V-PCRF may proxy the Rx Diameter Establishment Request to the H-PCRF directly (e.g. based on the stored information provided by H-DRA during the S9 Diameter session establishment).

7.4.2.2 Modification of Diameter sessions

The PCEF shall send the Diameter session modification message to the DRA to update the DRA binding information only if the UE's address(es) is updated and the DRA (redirect) is maintaining PCRF routing information per IP-CAN session. For visited access case, the V-PCRF shall send the Diameter session modification message to the H-DRA to update the DRA binding information only if the UE's address(es) is updated. The detailed procedure is similar to the Establishment of Diameter sessions, which is described in the clause 7.4.2.1.

7.4.2.3 Termination of Diameter Sessions

7.4.2.3.1 Non-roaming cases

Termination of Diameter sessions that impact the DRA binding occur at the following cases:

- Gateway control session termination
- IP-CAN session termination

The DRA client (BBERF/PCEF) shall follow the procedure below if the DRA (redirect) is maintaining PCRF routing information per IP-CAN session or an appropriate cached route table entry created from previous DRA (redirect) interactions does not exist. Cached route table entries are created from the Redirect-Host, Redirect-Host-Usage and Redirect-Max-Cache-Time AVPs as described in section 6.12, 6.13 and 6.14 of IETF RFC 3588 [14].

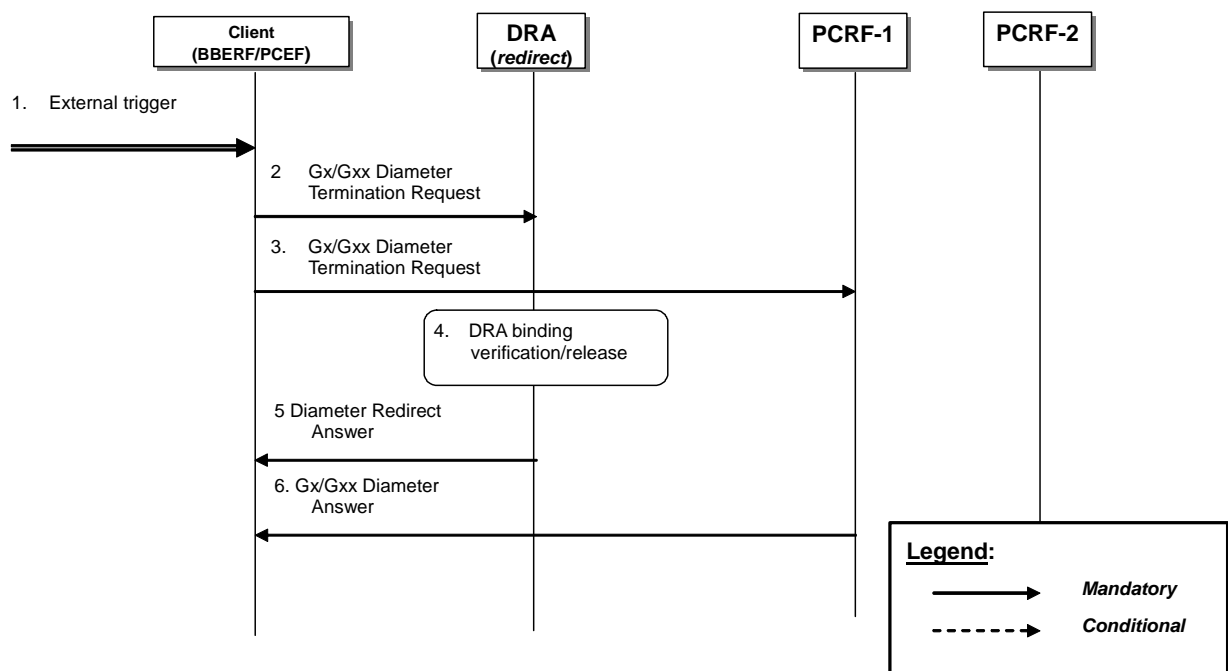

Figure 7.4.2.3.1.1: Termination of Diameter sessions through DRA (redirect)

1. Client receives an external trigger (e.g. an IP-CAN session termination is initiated by the UE or PCRF) that triggers the client to terminate Diameter session with server (i.e. PCRF)
2. A Diameter Termination Request (e.g., as defined in clauses 4.5.7 (Gx) and 4a.5.3 (Gxx) of 3GPP TS 29.212 [9]) is sent by the Client to the DRA (redirect).
3. A Diameter Termination Request (e.g., as defined in clauses 4.5.7 (Gx) and 4a.5.3 (Gxx) of 3GPP TS 29.212 [9]) is sent by the Client to PCRF-1. The message uses the same Session-Id AVP value of the active Diameter session established between the Client and PCRF-1.

NOTE: Steps 2, 3 may be carried out in parallel. Otherwise, the client after step2 may need to wait for the redirect answer before sending the Diameter termination request to the PCRF.

4. DRA (redirect) verifies that there is an active DRA binding for the IP-CAN session based on the Session-Id AVP and marks the Diameter session terminated. If the DRA binding is per IP-CAN session and all the Diameter sessions (i.e. Gx session or Gxx session) of that IP-CAN session are terminated or if the DRA binding is per UE and all the Diameter sessions (i.e. Gx session or Gxx session) of that UE are terminated the DRA removes the DRA binding.
5. DRA (redirect) acknowledges termination of the session by sending a Diameter redirect answer to the client.
6. PCRF-1 acknowledges termination of session. PCRF-1 sends a Diameter Answer (e.g., as defined in clauses 4.5.7 (Gx) and 4a.5.3 (Gxx) of 3GPP TS 29.212 [9]) to the Client.

NOTE: Figure 7.4.2.3.1.1 is also applicable when the BBERF/PCEF in the VPLMN terminates the Diameter sessions through the V-DRA.

7.4.2.3.2 Roaming cases

Termination of Diameter sessions occur at the following cases:

- S9 session termination

The DRA client (AF/BBERF/PCEF) shall follow the procedure below) if the DRA (redirect) is maintaining PCRF routing information per IP-CAN session or an appropriate cached route table entry created from previous DRA (redirect) interactions does not exist. Cached route table entries are created from the Redirect-Host, Redirect-Host-Usage and Redirect-Max-Cache-Time AVPs as described in section 6.12, 6.13 and 6.14 of IETF RFC 3588 [14].

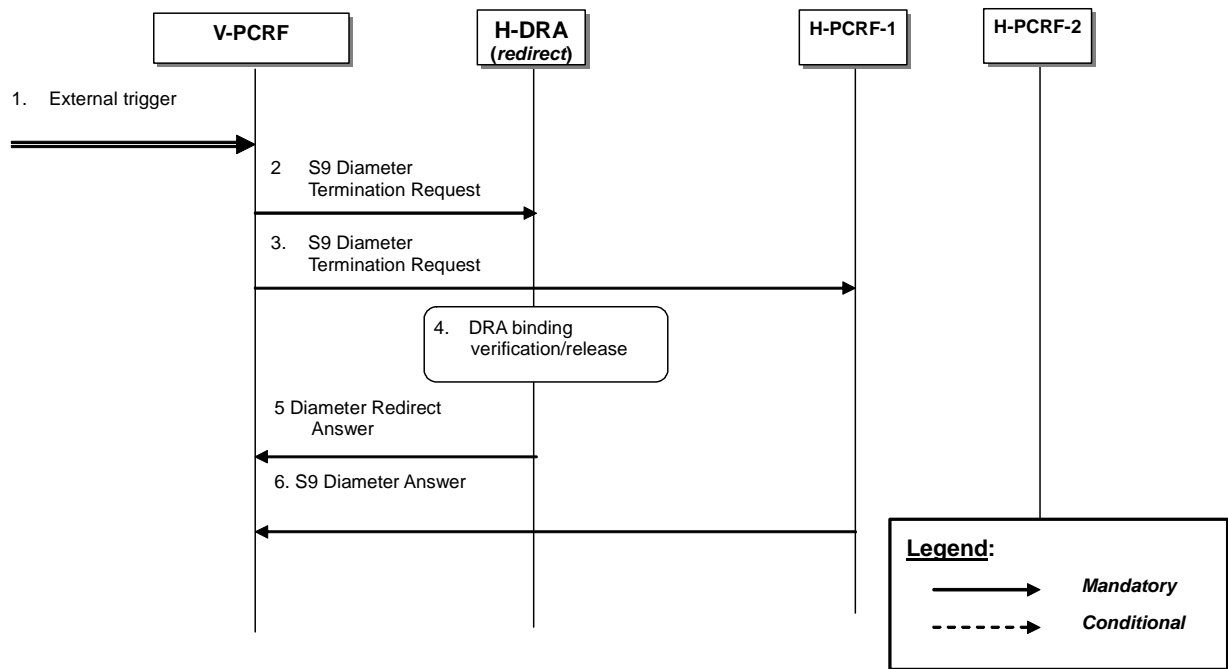

Figure 7.4.2.3.2.1: Termination of Diameter sessions through DRA (redirect) – Roaming case

1. V-PCRF receives an external trigger (e.g. session termination request from the BBERF, PCEF) that requires the sending of a Diameter Termination Request.
2. A Diameter Termination Request is sent by the V-PCRF and received by the H-DRA (redirect) in the home PLMN.
3. A Diameter Termination Request is sent by the V-PCRF to H-PCRF-1. The message uses the same Session-Id AVP value of the active Diameter session established between the V-PCRF and H-PCRF-1.

NOTE: Steps 2, 3 may be carried out in parallel. Otherwise, the V-PCRF after step 2 may need to wait for the redirect answer before sending the Diameter termination request to the H-PCRF

4. H-DRA (redirect) verifies that there is an active DRA binding for the IP-CAN session based on the Session-Id AVP and marks the Diameter session terminated. If all the Diameter sessions (i.e. S9 session, Gxx session, Gx session) of that UE are terminated the H-DRA removes the DRA binding.

5. H-DRA (redirect) acknowledges termination of the session by sending a Diameter redirect answer to the V-PCRF.

6. H-PCRF-1 acknowledges termination of the session by sending a Diameter answer to the V-PCRF.

NOTE: Rx Diameter termination messages are not required to be sent to H-DRA (redirect) since such messages do not affect the DRA binding

Annex A (informative):
Examples of deriving the Maximum Authorized parameters
from the SDP parameters

Annex B (normative): Signalling Flows for IMS

The signalling flows in Clause 4 are also applicable for IMS. This Annex adds flows that show interactions with SIP/SDP signalling of the IMS.

B.1 Subscription to Notification of Signalling Path Status at IMS Registration

This clause covers the Subscription to Notifications of IMS Signalling Path Status upon an initial successful IMS Registration procedure.

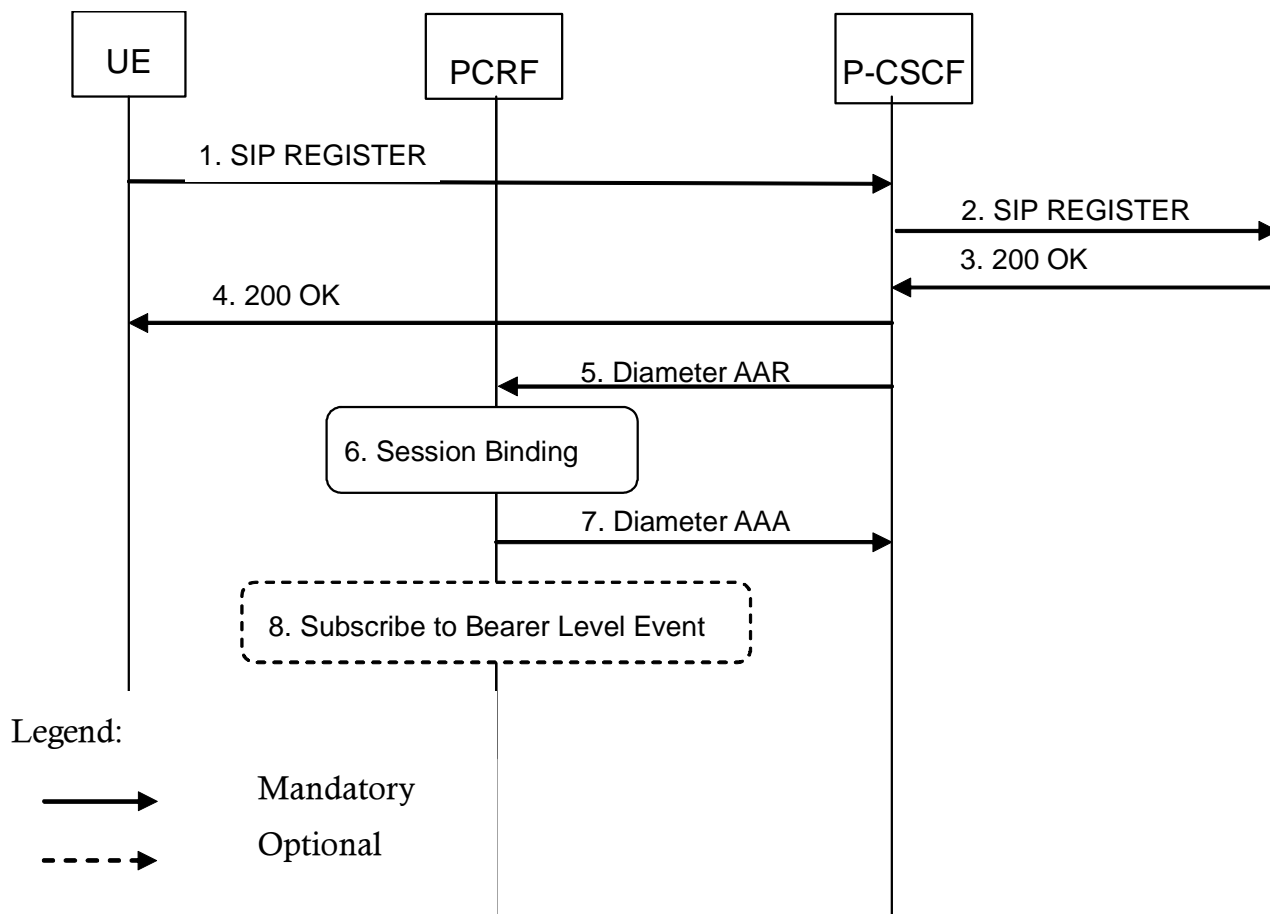

- 1-4. The user initiates an initial SIP Registration procedure. The SIP Registration procedure is completed successfully (user has been authenticated and registered within the IMS Core NW).
- 5. The P-CSCF requests the establishment of a new Diameter Rx session with the intention to subscribe to the status of the IMS Signaling path. The P-CSCF sends a Diameter AAR command to the PCRF.
- 6. The PCRF performs session binding and identifies corresponding PCC Rules related to IMS Signalling.
- 7. The PCRF confirms the subscription to IMS Signaling path status and replies with a Diameter AAR command back to the P-CSCF.
- 8. If the PCRF had not previously subscribed to the required bearer level events from the IP-CAN for the affected PCC/QoS Rules, then the PCRF shall do so now. The PCRF initiates procedures according to figure 4.3.1.1.1.

Figure B.1.1: Subscription to Notification of IMS Signaling Path Status at initial IMS Registration

B.1a Subscription to Notification of Change of IP-CAN Type at IMS Registration

This clause covers the Subscription to Notifications of change in the type of IP-CAN upon an initial IMS Registration procedure.

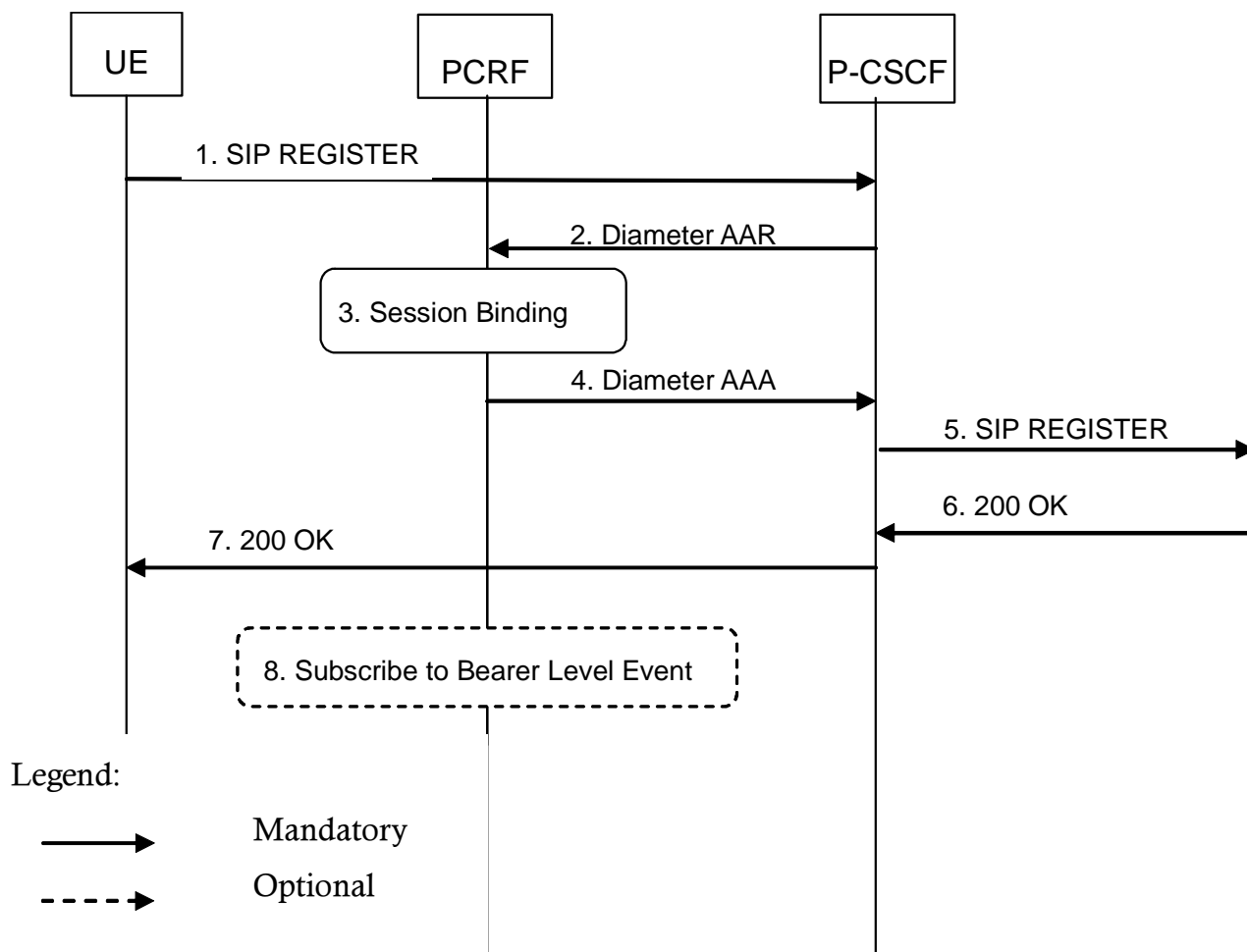

- 1. The user initiates an initial SIP Registration procedure.
- 2. The P-CSCF requests the establishment of a new Diameter Rx session with the intention to subscribe to the notification of IP-CAN Type Change. The P-CSCF sends a Diameter AAR command to the PCRF.

NOTE: It should be possible for the P-CSCF to request the subscription to notification of IMS Signalling path status also in this step.

- 3. The PCRF performs session binding and identifies corresponding PCC Rules related to IMS Signalling.
- 4. The PCRF confirms the subscription to notification of change of IP-CAN type and replies with a Diameter AAR command back to the P-CSCF. The PCRF includes in the response the type of IP-CAN currently in use.
- 5-7. The SIP Registration procedure is completed successfully (user has been authenticated and registered within the IMS Core NW).
- 8. If the PCRF had not previously subscribed to the required bearer level events from the IP-CAN for the affected PCC/QoS Rules, then the PCRF shall do so now. The PCRF initiates procedures according to figure 4.3.1.1.1.

Figure B.1.2: Subscription to Notification of change of IP-CAN Type at initial IMS Registration

B.2 IMS Session Establishment

B.2.1 Provisioning of service information at Originating P-CSCF and PCRF

This clause covers the PCC procedures at the originating P-CSCF and PCRF at IMS session establishment.

In figure B.2.1.1 the P-CSCF derives the provisioning of service information to the PCRF from the SDP offer/answer exchange.

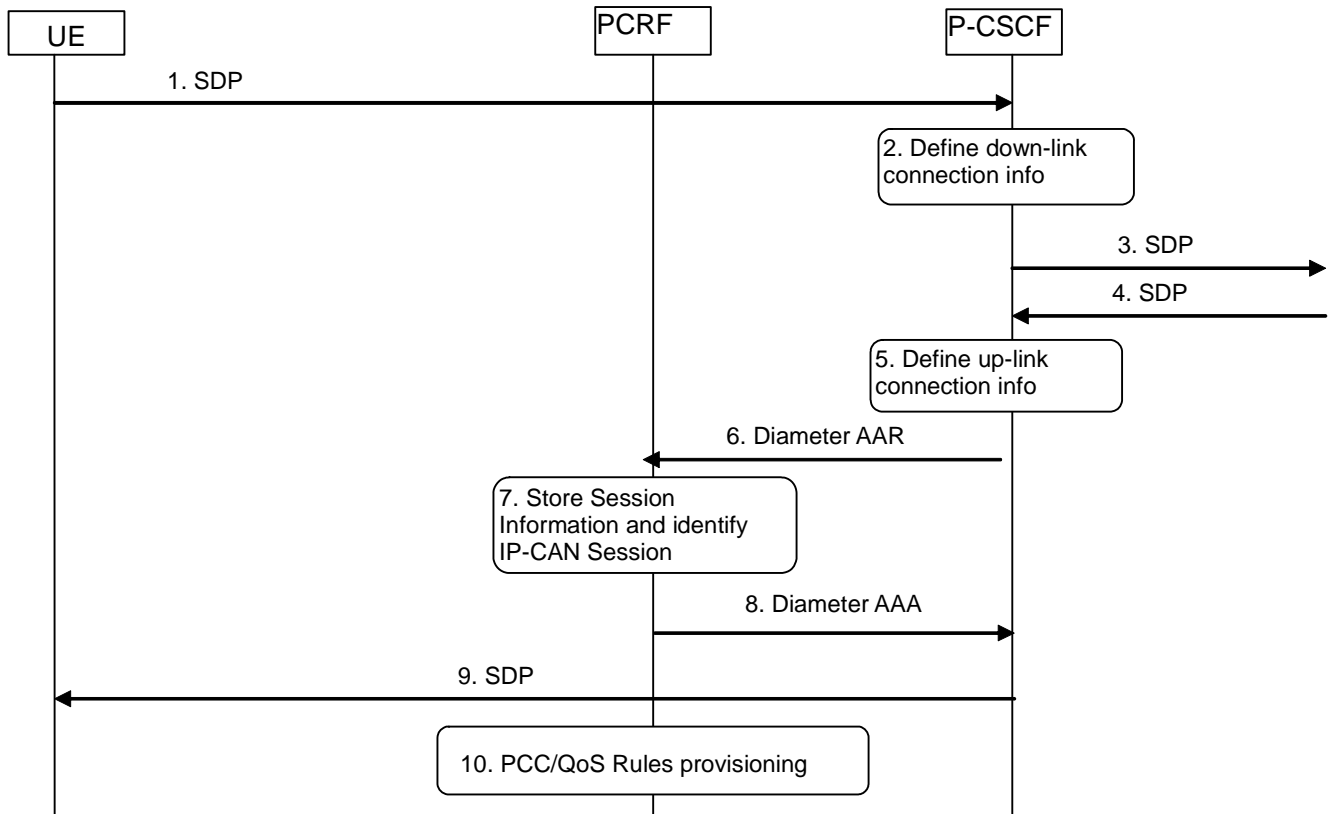

1. The P-CSCF receives the SDP parameters defined by the originator within an SDP offer in SIP signalling.
2. The P-CSCF identifies the connection information needed (IP address of the down link IP flow(s), port numbers to be used etc...).
3. The P-CSCF forwards the SDP offer in SIP signalling.
4. The P-CSCF gets the negotiated SDP parameters from the terminating side through SIP signalling interaction.
5. The P-CSCF identifies the connection information needed (IP address of the up-link media IP flow(s), port numbers to be used etc...).
6. The P-CSCF forwards the derived session information to the PCRF by sending a Diameter AAR over a new Rx Diameter session.
7. The PCRF stores the received session information and identifies the affected established IP-CAN Session(s).
8. The PCRF replies to the P-CSCF with a Diameter AAA.
9. Upon reception of the acknowledgement from the PCRF, the SDP parameters are passed to the UE in SIP signalling.
10. The PCRF executes interactions according to figure 4.3.1.1.1. This step implies provisioning of PCC/QoS rules and is executed in parallel with steps 8 and 9.

Figure B.2.1.1: PCC Procedures for IMS Session Establishment at originating P-CSCF and PCRF

Optionally, the provisioning of service information may be derived already from the SDP offer to enable that a possible rejection of the service information by the PCRF is obtained by the P-CSCF in time to reject the service with appropriate SIP signalling. This is described in figure B.2.1.2.

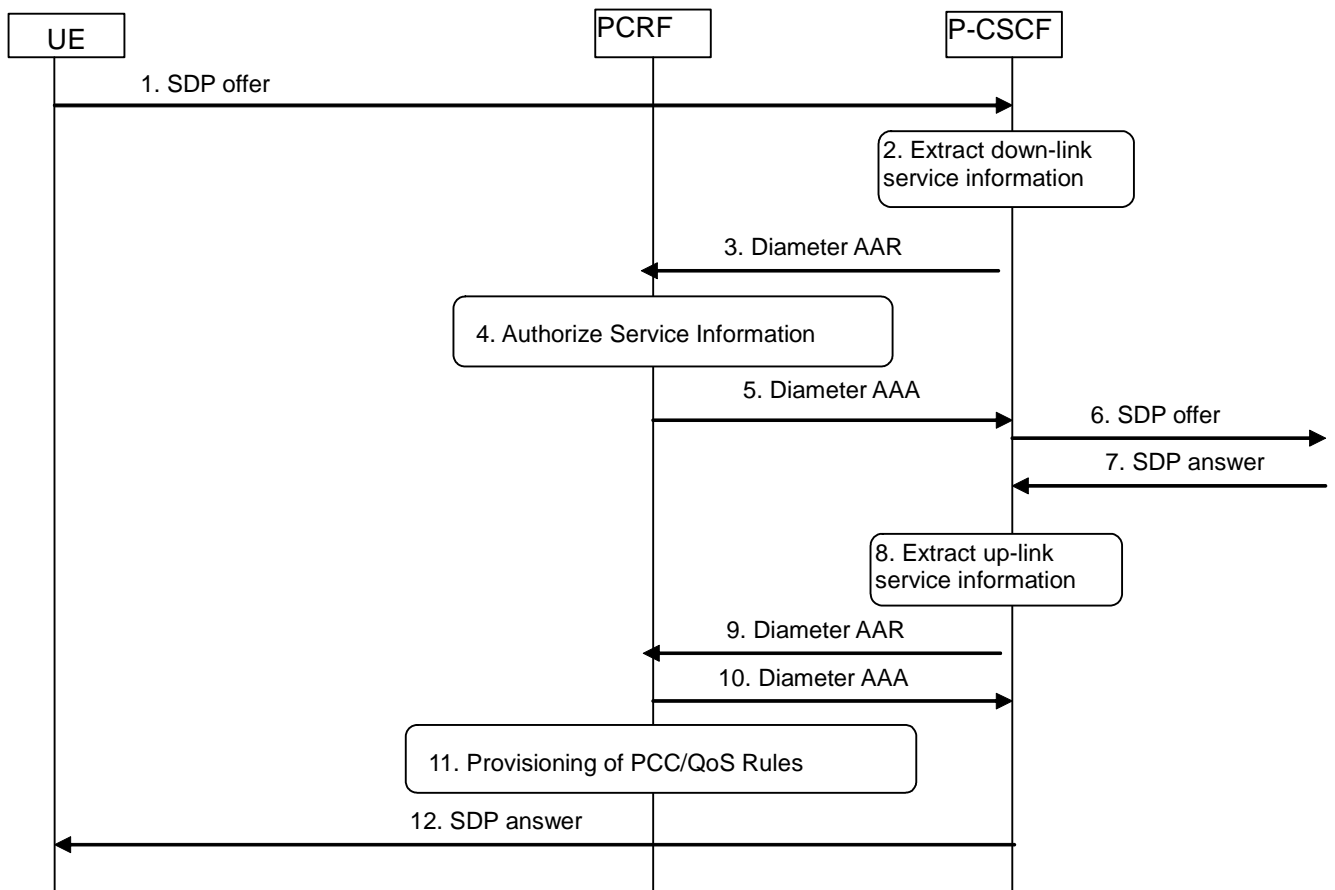

1. The P-CSCF receives the first SDP offer for a new SIP dialogue within a SIP INVITE request.
2. The P-CSCF extracts service information from the SDP offer (IP address of the down link IP flow(s), port numbers to be used etc...).
3. The P-CSCF forwards the derived service information to the PCRF by sending a Diameter AAR over a new Rx Diameter session. It indicates that only an authorization check of the service information is requested.
4. The PCRF checks and authorizes the service information, but does not provision PCC/QoS rules at this stage.
5. The PCRF replies to the P-CSCF with a Diameter AAA.
6. The P-CSCF forwards the SDP offer in SIP signalling.
7. The P-CSCF receives the negotiated SDP parameters from the terminating side within a SDP answer in SIP signalling.
8. The P-CSCF extracts service information from the SDP answer (IP address of the up-link media IP flow(s), port numbers to be used etc...).
9. The P-CSCF forwards the derived service information to the PCRF by sending a Diameter AAR over the existing Rx Diameter session.
10. The PCRF replies to the P-CSCF with a Diameter AAA.
11. The PCRF authorizes the session information. The PCRF executes interactions according to Figure 4.3.1.1.1. This step imply provisioning of PCC/QoS rules and authorized QoS.
12. Upon successful authorization of the session, the SDP parameters are passed to the UE in SIP signalling. This step is executed in parallel with step 11.

Figure B.2.1.2: PCC Procedures for IMS Session Establishment at originating P-CSCF and PCRF, provisioning of service information derived from SDP offer and answer

B.2.2 Provisioning of service information at terminating P-CSCF and PCRF

This clause covers the PCC procedures at the terminating P-CSCF and PCRF at IMS session establishment.

In figure B.2.2.1 the P-CSCF derives the provisioning of service information to the PCRF from the SDP offer/answer exchange.

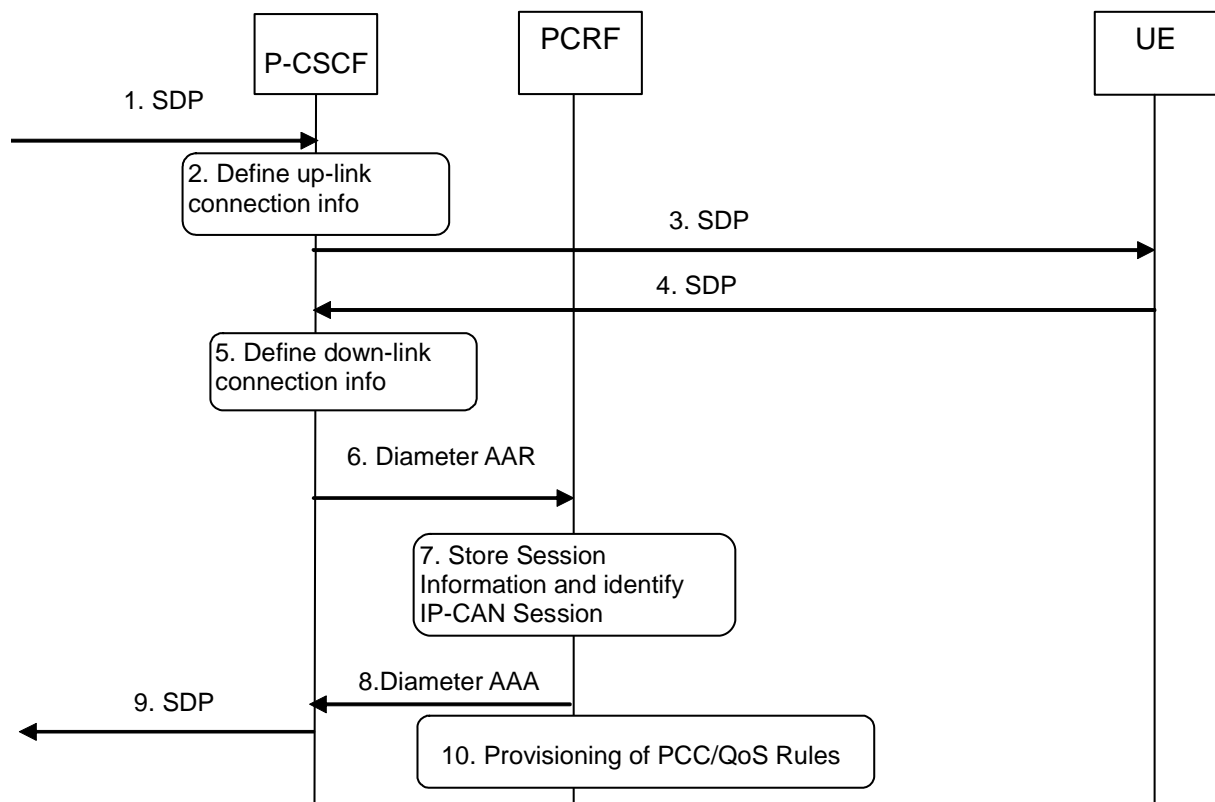

1. The P-CSCF receives the SDP parameters defined by the originator.
2. The P-CSCF identifies the connection information needed (IP address of the up-link IP flow(s), port numbers to be used etc...).
3. The P-CSCF sends the SDP offer to the UE.
4. The P-CSCF receives the negotiated SDP parameters from the UE.
5. The P-CSCF identifies the connection information needed (IP address of the down-link IP flow(s), port numbers to be used etc...).
6. The P-CSCF forwards the derived service information to the PCRF by sending a Diameter AAR over a new Rx Diameter session.
7. The PCRF stores the received session information and identifies the affected established IP-CAN Session(s).
8. The PCRF sends a Diameter AAA to the P-CSCF.
9. Upon reception of the acknowledgement from the PCRF, the SDP parameters in the SDP answer are passed to the originator.
10. The PCRF executes interactions according to section 4.3.1.1.1. This step implies provisioning of PCC/QoS rules and is executed in parallel with steps 8 and 9.

Figure B.2.2.1: PCC Procedures for IMS Session Establishment at terminating P-CSCF and PCRF

Optionally, the provisioning of service information may be derived already from the SDP offer to enable that a possible rejection of the service information by the PCRF is obtained by the P-CSCF in time to reject the service with appropriate SIP signalling or to enable pre-authorization for a UE terminated IMS session establishment with UE initiated resource reservation. This is described in figure B.2.2.2.

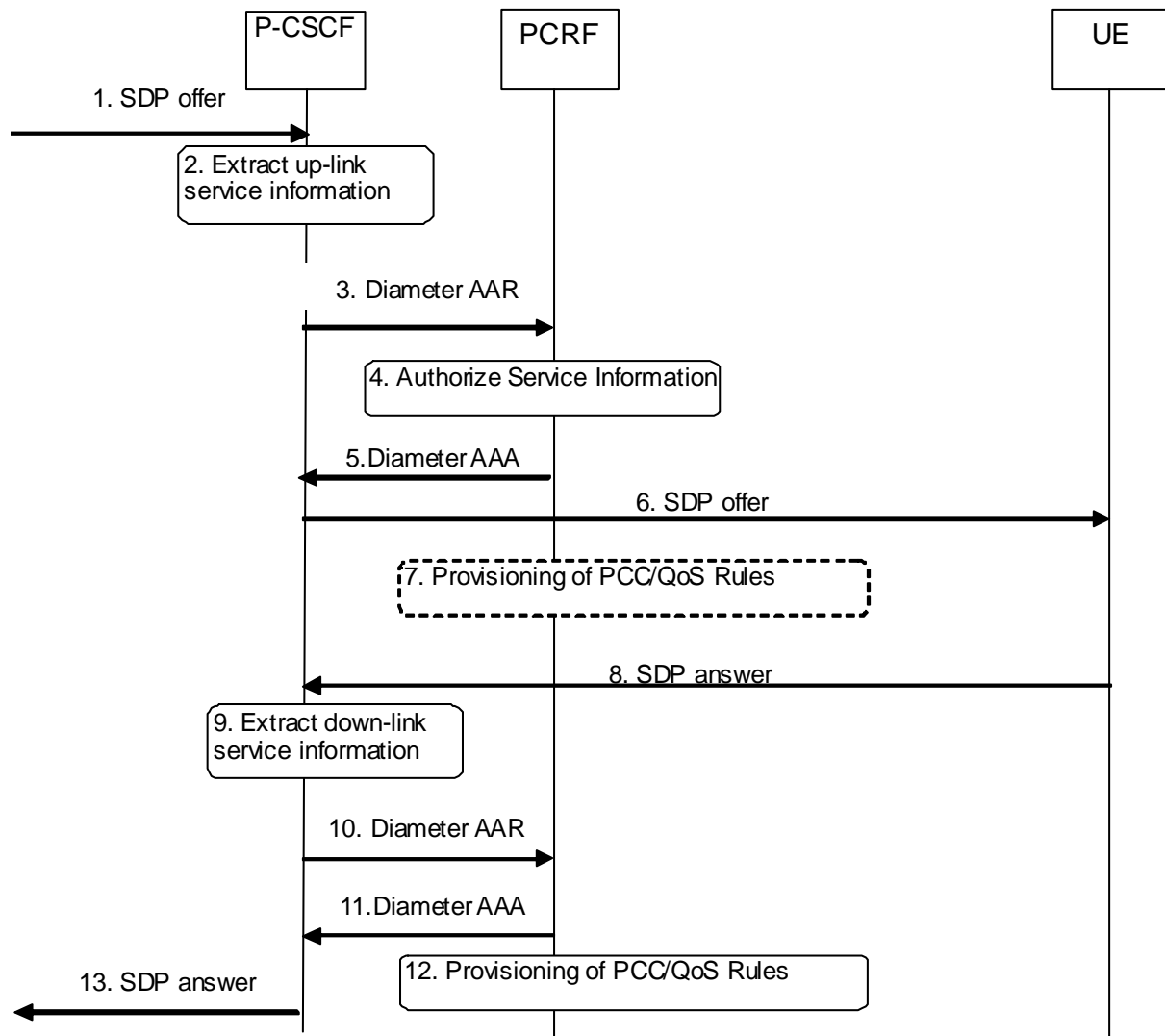

1. The P-CSCF receives the first SDP offer for a new SIP dialogue within SIP signalling, e.g. within a SIP INVITE request.
2. The P-CSCF extracts the service information from the SDP offer (IP address of the up-link IP flow(s), port numbers to be used etc...).
3. The P-CSCF forwards the derived session information to the PCRF by sending a Diameter AAR over a new Rx Diameter session. It indicates that the service information that the AF has provided to the PCRF is preliminary and needs to be further negotiated between the two ends.
4. The PCRF checks and authorizes the session information, but does not provisions PCC/QoS Rules at this stage.
5. The PCRF replies to the P-CSCF with a Diameter AAA.
6. The P-CSCF sends the SDP offer to the UE.
7. If the UE initiates a bearer resource modification request, the PCRF provides the PCEF/BBERF with PCC/QoS rules according to figure 4.3.1.1.1 based on the SDP offer.
8. The P-CSCF receives the negotiated SDP parameters from the UE within an SDP answer in SIP signalling.
9. The P-CSCF extracts service information from the SDP answer (IP address of the down-link IP flow(s), port numbers to be used etc...).
10. The P-CSCF forwards the derived service information to the PCRF by sending a Diameter AAR over the existing Rx Diameter session.
11. The PCRF sends a Diameter AAA to the P-CSCF.
12. The PCRF authorizes the session information. The PCRF executes interactions according to Figure 4.3.1.1.1. This step implies provisioning of PCC/QoS rules and authorized QoS.
13. Upon successful authorization of the session the SDP parameters in the SDP answer are passed to the originator. This step is executed in parallel with step 11.

Figure B.2.2.2: PCC Procedures for IMS Session Establishment at terminating P-CSCF and PCRF, provisioning of service information derived from SDP offer and answer

B.3 IMS Session Modification

B.3.1 Provisioning of service information

This clause covers the provisioning of service information at IMS session modification both at the originating and terminating side.

In figure B.3.1.1 the P-CSCF derives the provisioning of service information to the PCRF from the SDP offer/answer exchange.

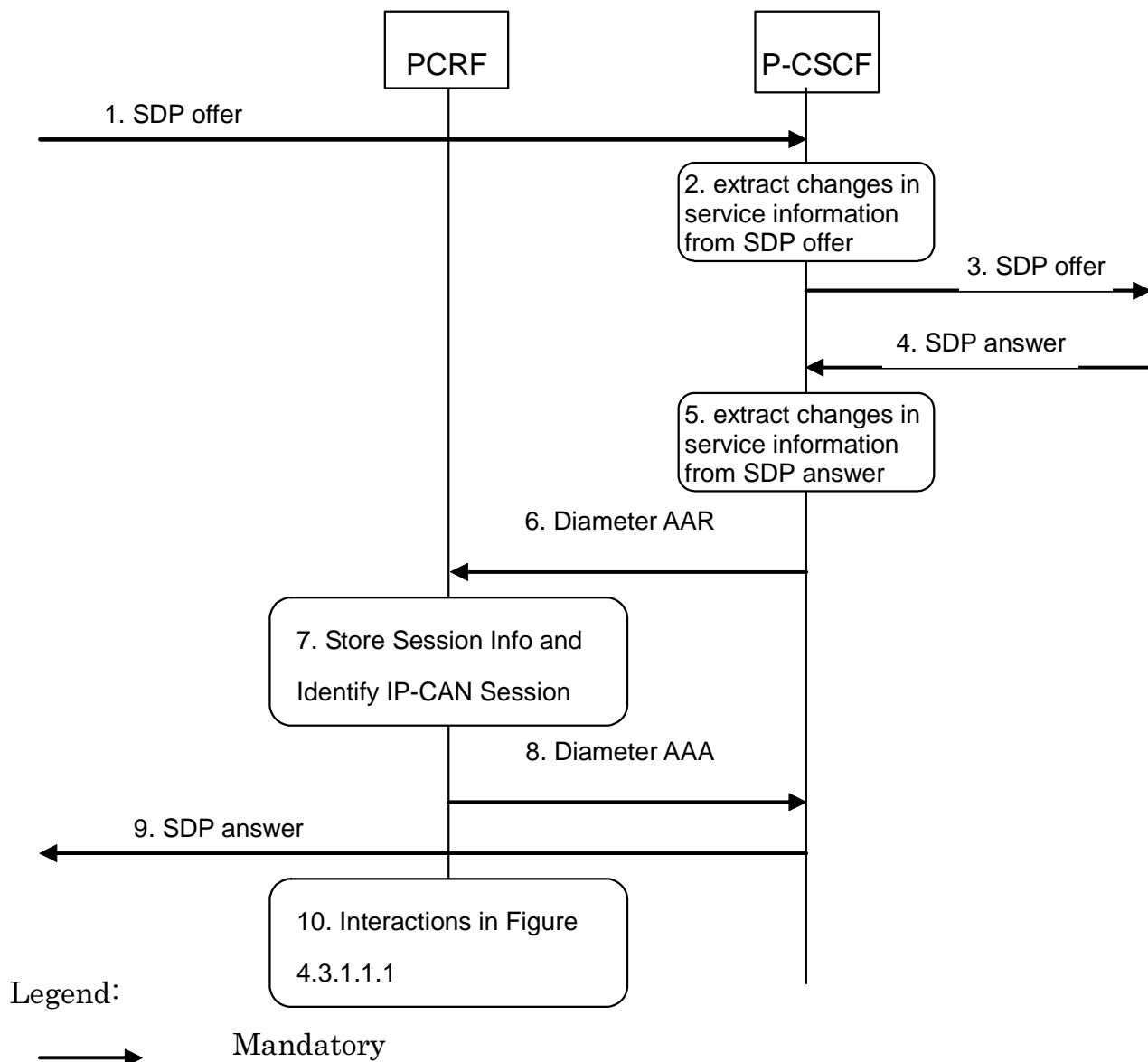

1. The P-CSCF receives the SDP parameters defined by the originator within an SDP offer in SIP signalling.
2. The P-CSCF identifies the relevant changes in the SDP.
3. The P-CSCF forwards the SDP offer in SIP signalling.
4. The P-CSCF gets the negotiated SDP parameters from the terminating side through SIP signalling interaction.
5. The P-CSCF identifies the relevant changes in the SDP.
6. The P-CSCF sends a Diameter AAR for an existing Diameter session and includes the derived updated service information.
7. The PCRF stores the received updated session information and identifies the affected established IP-CAN Session(s).

8. The PCRF answers with a Diameter AAA.
9. The P-CSCF forwards the SDP answer in SIP signalling.
10. The PCRF executes interactions according to figure 4.3.1.1.1. Due to the updated service information, this step may imply provisioning of PCC/QoS rules or the need to enable or disable IP Flows (see Clauses B.3.2 and B.3.3, respectively).

Figure B.3.1.1: Provisioning of service information at IMS session modification

Optionally, the provisioning of service information may be derived already from the SDP offer to enable that a possible rejection of the service information by the PCRF is obtained by the P-CSCF in time to reject the service with appropriate SIP signalling or to enable pre-authorization for a UE terminated IMS session establishment with UE initiated resource reservation. This is described in figure B.3.1.2.

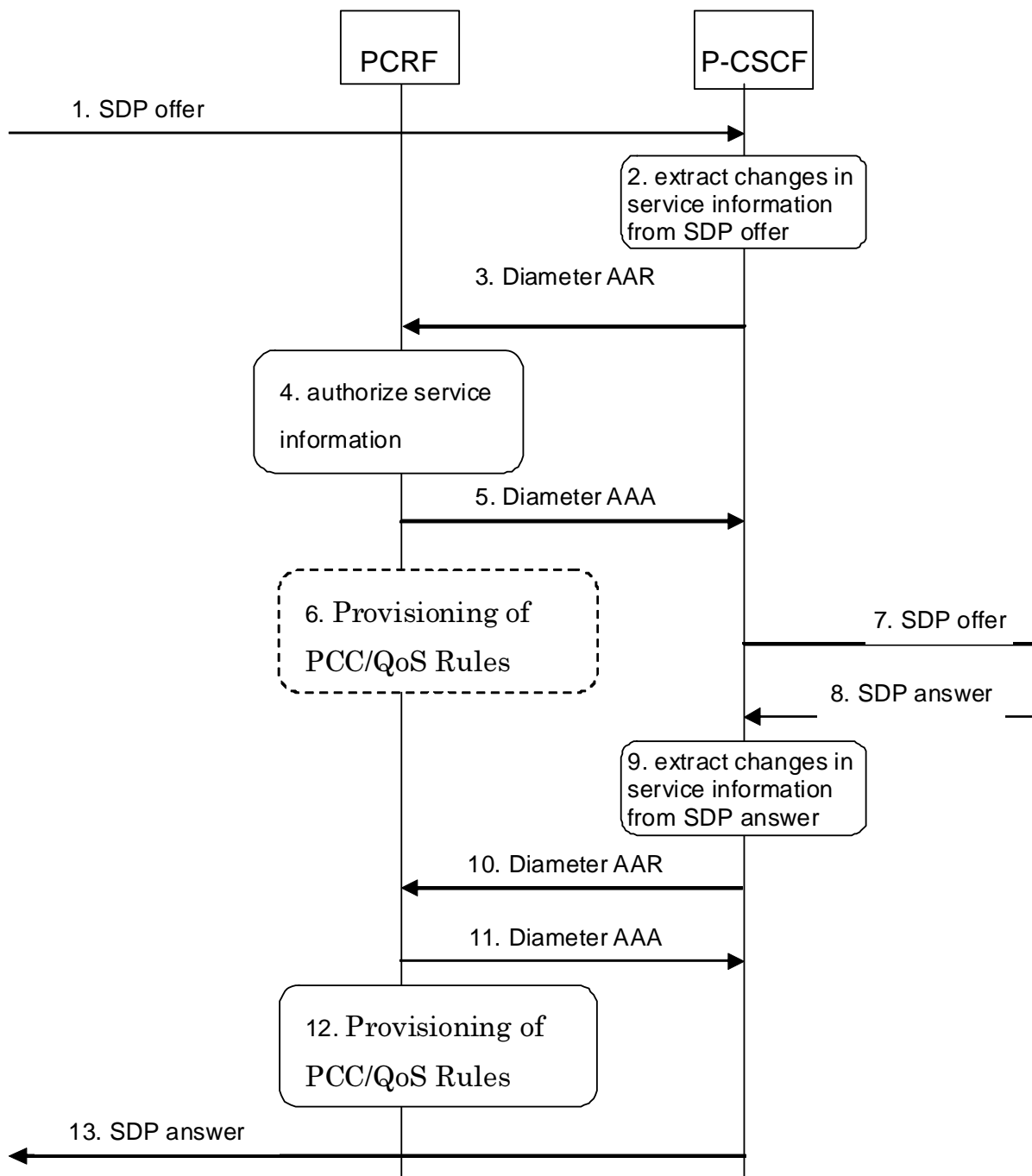

1. The P-CSCF receives an SDP offer in SIP signalling for an exiting SIP dialogue.
2. The P-CSCF identifies the relevant changes in the SDP and extracts the corresponding service information.
3. The P-CSCF forwards the derived service information to the PCRF by sending a Diameter AAR over the existing Rx Diameter session for the corresponding SIP session. It indicates that the service information that the AF has provided to the PCRF is preliminary and needs to be further negotiated between the two ends.
4. The PCRF checks and authorizes the session information, but does not provision PCC/QoS rules at this stage.
5. The PCRF replies to the P-CSCF with a Diameter AAA.
6. If the UE initiates a bearer resource modification request, the PCRF provides the PCEF/BBERF with PCC/QoS rules according to figure 4.3.1.1.1 based on the SDP offer.
7. The P-CSCF forwards the SDP offer in SIP signalling.

8. The P-CSCF receives the negotiated SDP parameters within an SDP answer in SIP signalling from the terminating side.
9. The P-CSCF identifies the relevant changes in the SDP and extracts the corresponding service information.
10. The P-CSCF sends a Diameter AAR for an existing Diameter session and includes the derived updated service information.
11. The PCRF answers with a Diameter AAA.
12. The PCRF interacts with the GW according to figure 4.3.1.1.1. This step may imply provisioning of PCC/QoS rules and authorized QoS. The PCRF may need to enable or disable IP Flows (see Clauses B.3.2 and B.3.3, respectively) due to the updated service information.
13. The P-CSCF forwards the SDP answer in SIP signalling. This step is executed in parallel with step 11.

Figure B.3.1.2: Provisioning of service information derived from SDP offer and answer at IMS session modification

B.3.2 Enabling of IP Flows

The PCRF makes a final decision to enable the allocated QoS resource for the authorized IP flows of the media component (s) if the QoS resources are not enabled at the time they are authorized by the PCRF or if the media IP flow(s) previously placed on hold are resumed, i.e. the media IP flow(s) of the media component that was placed on hold at the time of the resource authorization or at a later stage is reactivated (with SDP direction sendrecv, sendonly, recvonly or none direction).

The Enabling of IP Flows procedure is triggered by the P-CSCF receiving any 2xx success response to an INVITE request or a 2xx success response to an UPDATE request within a confirmed dialogue that is not embedded as part of another INVITE Transaction (in both cases a 200 OK response is usually received). When receiving such responses, the PCRF shall take the SDP direction attribute in the latest received SDP (either within the 2xx success or a previous SIP message) into account when deciding, which gates shall be opened:

- For a unidirectional SDP media component, IP flows in the opposite direction shall not be enabled.
- For an inactive SDP media component, no IP flows shall be enabled.

Figure B.3.2.1 is applicable to the Mobile Originating (MO) side and the Mobile Terminating (MT) side.

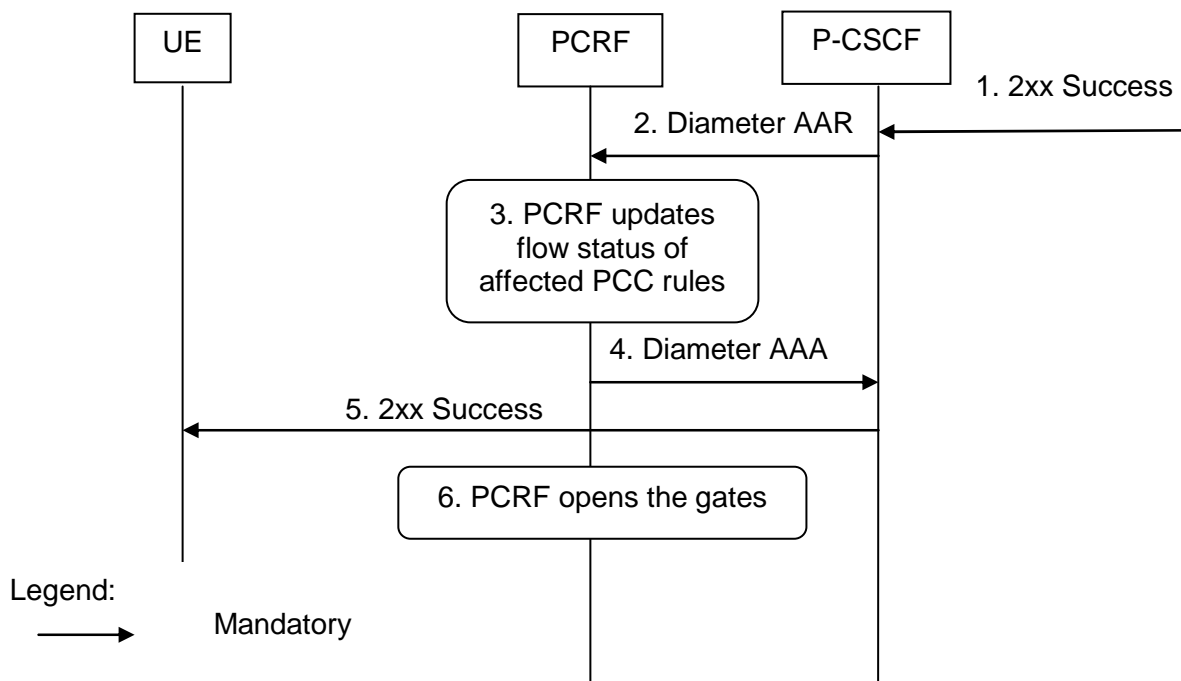

1. The P-CSCF receives the 2xx Success message complying with the conditions specified in the paragraphs above.
2. The P-CSCF sends a Diameter AAR message to the PCRF, requesting that gates shall be opened.
3. The PCRF approves the enabling of IP flows and PCRF updates flow status of affected PCC rules.
4. The PCRF sends a Diameter AAA to the P-CSCF.
5. The P-CSCF forwards the 2xx Success message.
6. The PCRF executes interactions according to figure 4.3.1.1.1. This step implies opening the "gates" by updating the flow status of PCC rules.

Figure B.3.2.1: Enabling of IP Flows

B.3.3 Disabling of IP Flows

The "Disabling of IP Flows" procedure is used when media IP flow(s) of a session are put on hold (e.g. in case of a media re-negotiation or call hold).

Media is placed on hold as specified in RFC 3264 [11]. Media modified to become inactive (SDP direction attribute) shall also be considered to be put on hold.

If a bidirectional media component is placed on hold by making it unidirectional, the IP flows shall only be disabled in the deactivated direction. If a media component is placed on hold by making it inactive, the IP flows shall be disabled in both directions.

Figure B.3.3.1 presents the "Disabling of IP Flows" procedure at media on hold for both the Mobile Originating (MO) side and the Mobile Terminating (MT) side.

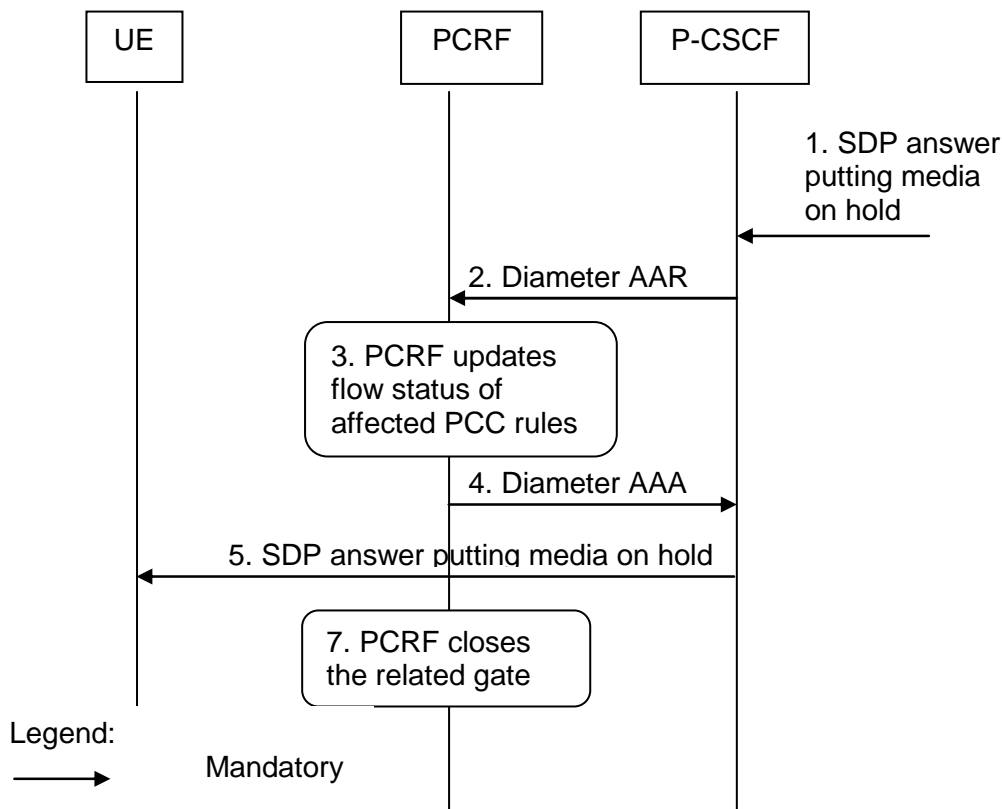

1. The P-CSCF receives an SDP answer putting media on hold within a SIP message. (NOTE 1)
2. The P-CSCF sends a Diameter AAR request to the PCRF, requesting that gates shall be closed.
3. The PCRF updates flow status of affected PCC rules for the media on hold.
4. The PCRF sends a Diameter AAA message back to the P-CSCF.
5. The P-CSCF forwards the SDP answer putting media on hold within a SIP message.
6. The PCRF executes interactions according to figure 4.3.1.1.1. This step implies closing the relevant media IP flow gate(s), leaving the possible related RTCP gate(s) open to keep the connection alive.

NOTE: This procedure occurs whenever a bidirectional media is made unidirectional or when a media is changed to inactive.

Figure B.3.3.1: Disabling of IP Flows at Media on Hold

B.3.4 Media Component Removal

Figure B.3.4.1 presents the flows of PCC procedures at the removal of media component(s) from an IMS session which is not being released for both the Mobile Originating (MO) side and the Mobile Terminating (MT) side.

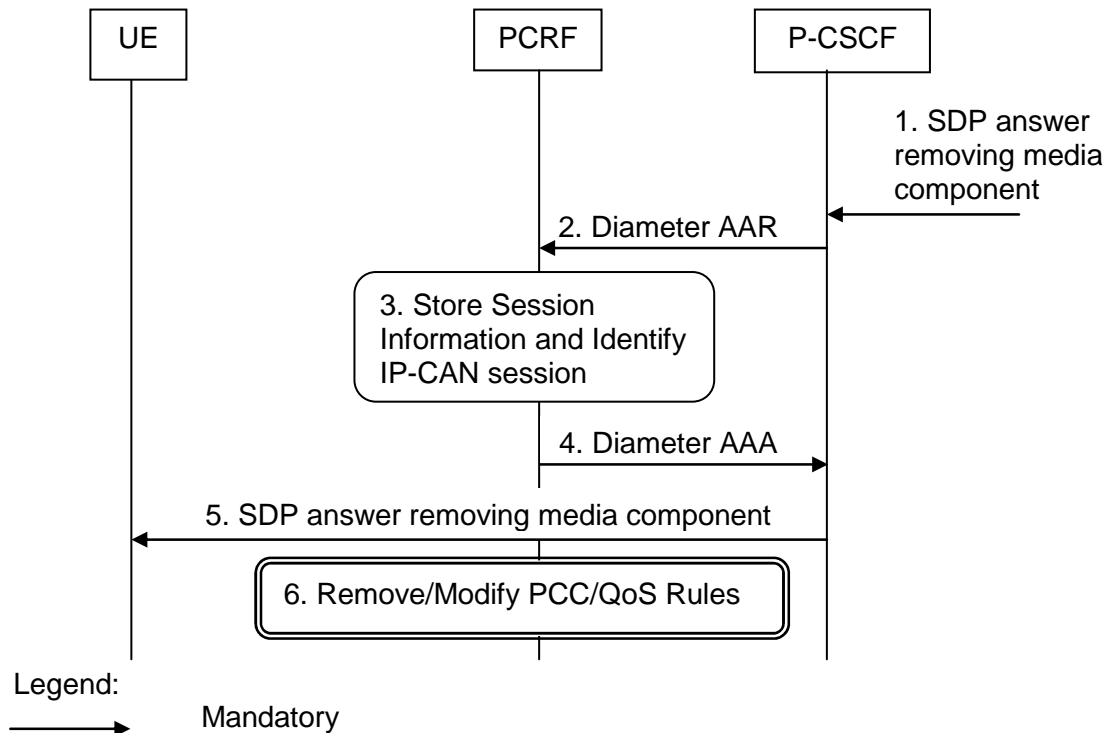

1. A SIP message containing SDP indicating the removal of media component(s) is received by the P-CSCF.
2. The P-CSCF sends Diameter AAR to the PCRF with modified service information.
3. The PCRF stores the Session information and identifies the affected IP-CAN Session(s).
4. The PCRF sends a Diameter AAA message back to the P-CSCF.
5. The P-CSCF forwards the SDP answer removing a media component.
6. The PCRF makes a decision on what PCC/QoS rules need to be modified or removed and executes interactions according to figure 4.3.1.1.1.

Figure B.3.4.1: Revoke authorization for IP resources at media component removal for both Mobile Originating (MO) and Mobile Terminating (MT) side

B.4 IMS Session Termination

B.4.1 Mobile initiated session release / Network initiated session release

Figure B.4.1.1 presents the mobile or network initiated IMS session release for both the Mobile Originating (MO) side and the Mobile Terminating (MT) side. The session release may be signalled by a SIP BYE message, or any SIP 3xx redirect response, or any 4xx, 5xx, or 6xx SIP final error response to an initial INVITE request. If any 4xx, 5xx, or 6xx SIP final error response to Re-INVITE or UPDATE request just terminates the transaction, then the session is not released, otherwise if the error response terminates the dialog then the session is released.

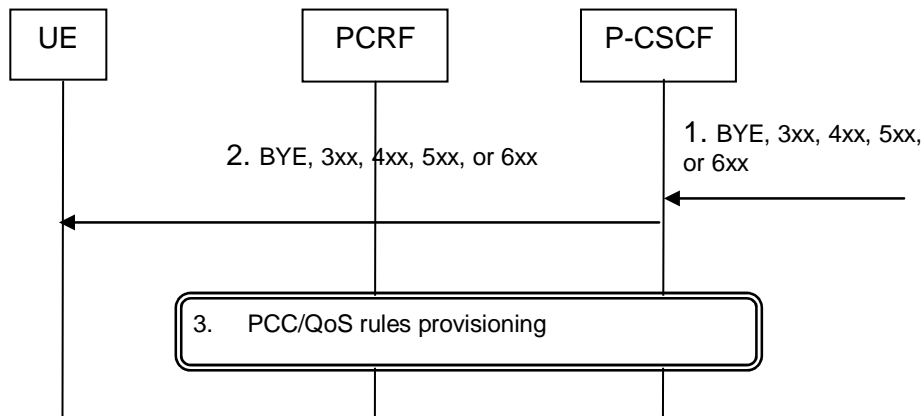

1. SIP BYE message, a SIP 3xx redirect response, or any 4xx, 5xx, or 6xx SIP final error response to an initial INVITE or any 4xx, 5xx, or 6xx SIP final error response to Re-INVITE or UPDATE which terminates the dialog is received by the P-CSCF.
2. P-CSCF forwards the BYE message, or the SIP 3xx redirect response, or any 4xx, 5xx, or 6xx SIP final error response.
3. The Interactions in Figure 4.3.1.1.1 are applicable.

Figure B.4.1.1: IMS session termination

B.4.2 IP-CAN Bearer Release/Loss

An IP-CAN Bearer Release or Loss event may affect all IP-Flows within an IMS Session. Flows in clause 4.3.2.2.1 (AF located in the HPLMN) or 4.3.2.2.2 (AF located in the VPLMN) apply for case 1. Flows in clause 4.4.2.1.1 (Home Routed case) or 4.4.2.2.1 (Visited Access case) apply for case 2a and case 2b.

Annex C (normative): NAT Related Procedures

C.1 Support for media traversal of NATs using ICE

The IMS calls out procedures for NAT traversal for media and signaling within IMS. One of the methods supported by IMS for media traversal of NATs is a UE controlled NAT traversal solution based on the IETF Interactive Connectivity Establishment (ICE) protocol, IETF RFC 5245 [15]. When a UE uses the ICE protocol for media traversal of NATs, additional enhancements to the existing PCC procedures are necessary to allow for proper ICE operation.

This annex presents a set of rules that PCC network elements use to build flow descriptors, identify the proper UE IP addresses used by the PCRF for session and bearer binding, and gating control when the ICE procedures are invoked by the UE.

In order for the ICE procedures to work a static, preconfigured PCC rule needs to be in place at the PCEF which allows the UE to perform STUN binding requests prior to offering or answering an SDP.

NOTE 1: Predefined PCC rules can be created to allow the UE to communicate with the STUN relay much in the same way the UE is allowed to communicate with the IMS network for session management.

NOTE 2: Given that a STUN relay is a forwarding server under the direction of the UE, necessary precaution needs to be taken by the operator in how it chooses to craft these rules. It is recommended that such predefined rules only guarantee the minimal amount of bandwidth necessary to accomplish the necessary UE to STUN relay communication. Such an approach helps reduce the resources required to support NAT traversal mechanisms. Finally, such an approach allows the preconfigured rule to be over-ridden by dynamic rules which allow for the necessary bandwidth needed by the session.

NOTE 3: The dynamic PCC rule will need to differentiate between different media traffic between UE and STUN relay (e.g. voice vs. video), which can be identified by the different ports assigned by the residential NAT. Session bindings need to take into account that the relevant terminal IP address may be contained within the ICE candidates contained in the session description, rather than in the normal media description.

NOTE 4: It is assumed that the NAT device is located between the UE and the PCEF. NAT traversal outside of IMS in FBI services is considered FFS in the current 3GPP stage 2 specifications.

NOTE 5: When a NAT device is located between the UE and the PCEF, it is assumed that the IP CAN session signalling will contain the IP address assigned by the residential NAT, rather than the UE IP address.

NOTE 6: It is assumed that NAT devices that assign multiple IP addresses for the UE are outside the scope of release 7.

NOTE 7: In this release, only one IP address per subscription is supported by session binding at the PCRF. Multiple UEs behind a NAT will use the same IP CAN session and IP address.

C.2 P-CSCF procedures

C.2.1 General

The procedures in clause C.2 are only invoked in the case where the local UE (uplink SDP) has utilized the ICE protocol for media traversal of NATs. The P-CSCF can determine this by inspecting the UE provided SDP (uplink) for the "a=candidate" attribute(s). If such attributes are present this is an indication that the UE has invoked the ICE procedures as defined in IETF RFC 5245 [15] for media traversal of NATs and the P-CSCF shall follow the requirements in clause C.2.

C.2.2 Deriving the UEs IP address

The P-CSCF shall set the Framed-IP-Address AVP or Framed-IPv6-Prefix AVP to the source IP address of SIP messages received from the UE.

C.2.3 Deriving flow descriptions

In the case where STUN Relay and ICE are used for NAT traversal, the UE is required to place the STUN Relay provided address in the "m=" and "c=" lines of its SDP. Given that these addresses cannot be used by the P-CSCF for building a valid flow description, the P-CSCF will need to determine if a STUN Relay address has been provided in the "m=" and "c=" lines of the UE provided SDP (uplink only). The P-CSCF shall make this determination by inspecting the uplink SDP for "a=candidate" attributes and compare the candidate address with that contained in the "c=" line. If a match is found, the P-CSCF shall then look at the candidate type. If the candidate type is "relay" then the address in the "c=" line is that of a STUN Relay server. In this case, the P-CSCF shall derive the Flow-Description AVP within the service information from the SDP candidate type of "relay" as follows:

Uplink Flow-Description

- Destination Address and Port: If the P-CSCF knows the destination address and port of the STUN Relay allocation that the UE is sending media to, it should use that information. If the P-CSCF does not know this address and port, it shall wildcard the uplink destination address and port.
- Source Address and Port: The P-CSCF shall populate the uplink source address with the "rel-addr" address and the uplink source port with the "rel-port" port contained within the "a=candidate" attribute.

Downlink Flow-Description

- Destination Address and Port: The P-CSCF shall populate the downlink destination address with the "rel-addr" address and the downlink destination port with the "rel-port" port contained within the "a=candidate" attribute.
- Source Address and Port: If the P-CSCF knows the source address and port of the STUN Relay allocation that the UE is receiving media from, it should use that information. If the P-CSCF does not know this address and port, it shall wildcard the downlink source address and port.

For the other candidate types, the address in the "c=" and "m=" SDP attributes can be used for building the flow descriptor and the P-CSCF shall follow the rules to derive the Flow-Description AVP as described in table 6.2.2 of clause 6.2 of this TS.

C.2.4 Gating control

If both endpoints have indicated support for ICE (both the SDP offer and answer contain SDP attributes of type "a=candidate") ICE connectivity checks will take place between the two UEs. In order to allow these checks to pass through the PCEF, the P-CSCF shall enable each flow description for each media component upon receipt of the SDP answer.

C.2.5 Bandwidth impacts

ICE has been designed such that connectivity checks are paced inline with RTP data (sent no faster than 20ms) and thus consumes a lesser or equal amount of bandwidth compared to the media itself (given the small packet size of a STUN connectivity check it is expected that the STUN connectivity checks will always have a smaller payload than the media stream itself). Thus, there are no additional requirements on the P-CSCF for bandwidth calculations for a given media flow.

C.3 PCRF procedures

C.3.1 General

The procedures in clause C.3 are only invoked when the following two conditions are met:

1. Both the local and remote UE have utilized the ICE protocol for media traversal of NATs (see subclause C.2.1 for details on how this is determined); and
2. The IP-CAN which is servicing the IMS session does not support the concept of a default bearer.

C.3.2 Deriving additional flow descriptions

The PCRF may need to develop additional flow descriptions (beyond those provided by the P-CSCF) for a media component based on additional candidate addresses present in the SDP offer/answer exchange. The PCRF shall follow the procedures defined in IETF RFC 5245 [15] for forming candidate pairs based on the data contained within the received codec-data AVP. For each candidate pair created based on the ICE procedures and not already present in the received flow descriptions, the PCRF shall add an uplink and downlink flow description for each media component.

NOTE 1: The uplink SDP represents the local candidates while the downlink SDP represents the remote candidates.

Following the ICE procedures for forming candidate pairs will result in some flow descriptions which would never be exercised. In particular, while the UE will send connectivity checks (and ultimately its media stream) from its host candidate, from the PCEF perspective, this will appear as being from the server reflexive address. Given this, the PCRF should not form flow descriptions using host candidate addresses and should only form additional flows based on server reflexive addresses and relay addresses.

As candidates are removed from the SDP via subsequent offer/answer exchanges, the PCRF shall update its candidate pair list and shall remove any flow descriptors no longer being used.

NOTE 2: If the default candidate (the candidate used to populate the "c=" and "m=" lines of both the uplink and downlink SDP) is chosen, then an updated SDP offer/answer will not be done, and any extra flow descriptions not being used by the session will not be removed.

C.3.3 Gating control

For each additional flow description the PCRF adds to a media component (per sub-clause C.3.2), the PCRF shall enable the flow in order to allow connectivity checks to pass.

C.3.4 Bandwidth impacts

Per clause C.2.5 ICE is designed to have minimal impact on bandwidth policy control. However, it is possible that media will begin flowing while the ICE connectivity checks are still in progress. Given the possibility that no session update will be made (the default candidates will be chosen by the ICE protocol), it is not recommended that the PCRF adjust the bandwidth parameters provided by the P-CSCF.

Annex D (normative): Access specific procedures for GPRS

D.1 General

The present annex defines IP-CAN specific requirements for General Packet Radio Service (GPRS).

D.2 Binding Mechanisms

Depending on the bearer control mode, bearer binding can be executed either by PCRF, PCEF or both PCRF and PCEF.

- For "UE-only" IP-CAN bearer establishment mode, the PCRF performs bearer binding.
- For "UE/NW" IP-CAN bearer establishment mode, the PCRF performs the binding of the PCC rules for user controlled services while the PCEF performs the binding of the PCC rules for the network controlled services.

In GPRS access, if there is no suitable PDP-Context to accommodate a PCC rule when PCEF performs the bearer binding, the PCEF shall initiate the establishment of PDP-Contexts as specified in 3GPP TS 23.060 [3].

If the PCEF performs the bearer binding, the PCRF shall follow the procedures as described in Clause 5.4.

If the Bearer Binding function is located at the PCRF, the PCRF shall compare the TFT(s) of all IP-CAN bearer(s) within the IP-CAN session received via PCEF from the UE with the existing service data flow filter information. The PCRF shall indicate to the PCEF the IP-CAN bearer within the IP-CAN session where the PCC Rules shall be installed, modified or removed. This is done including the Bearer-Identifier AVP together with the associated PCC Rules within the corresponding RAR and/or CCA commands.

- When the PCRF does not require additional filter information coming from the UE in order to decide on bearer binding, the PCRF shall supply the PCC rules to be installed over the Gx interface to the PCEF within a RAR command.
- Otherwise, the PCRF shall wait for the PCEF requesting a policy decision for the establishment of a new IP-CAN bearer or the modification of an existing one within a CCR command over the Gx interface.
- In GPRS access when the PCEF reports the bearer event, it shall include within the CCR command a bearer reference together with the new or modified TFT information, the QoS class identifier and associated bitrates for new or modified PDP-Contexts.

D.3 PCC Procedures

D.3.1 IP-CAN Session Modification

D.3.1.1 Network-initiated IP-CAN Session Modification

Network-initiated IP-CAN session modification is executed according to clause 4.3.1.1 with the following differences:

- The timer in step 4 will also be activated waiting for one of the following cases:
 - o If the authorized QoS for an IP-CAN bearer is changed or
 - o If one or more Flow Descriptions need to be added, deactivated or removed in any of the PCC rules bound to an IP-CAN bearer

- If the timer in step 4 expires and the PCRF still requires additional filter information coming from the UE in order to decide on bearer binding for new PCC rules to be installed, all subsequent steps in figure 4.3.1.1.1 shall not be executed, and further reactions of the PCRF are left unspecified. As a possible option, the PCRF could abort the AF session.
- When the PCRF performs the bearer binding, once the PCC rules are selected, the PCRF identifies the IP-CAN bearer for each of the PCC rules and the authorized QoS. The PCRF may provision PCC Rules and authorized QoS for several IP-CAN Bearers within the same RAR command.
- For step 9, IP-CAN session signalling, the subsequent steps are executed separately for each IP-CAN bearer under the following conditions:
 - o if all PCC rules bound to a PDP context have been removed or deactivated (PDP Context deactivation is applicable)
 - o if one or more PDP contexts have to be modified
 - o if in UE/NW Bearer Control Mode, the GGSN needs to establish a new PDP context(PDP Context establishment is applicable) if the bearer binding is located at the PCEF.

The GGSN initiates the procedure to Create/Update or Terminate PDP Context Request message to the SGSN. If in the case of updating the PDP Context the authorized QoS for the bearer has changed, the GGSN will modify the UMTS QoS parameters accordingly.

When the procedure in step 9 is completed and requires notifications from the GW, for an IP-CAN Bearer termination in UE-Only Bearer Control Mode, the GGSN sends a Diameter CCR with the Bearer-Identifier and Bearer-Operation AVPs to indicate "Termination".

D.3.1.2 PCEF-initiated IP-CAN Session Modification

PCEF-initiated IP-CAN Session Modification procedure shall take place according to clauses 4.3.2.1 and 4.3.2.2 except for those procedures initiated by the UE, as described in the clauses below.

D.3.1.2.1 UE-initiated IP-CAN Bearer Establishment or IP-CAN Bearer Modification

This clause is applicable for the establishment of a new IP-CAN Bearer (other than the one which created the IP-CAN session) and for the modification of an already established IP-CAN Bearer. The signalling flows for these cases are as per Figure 4.3.1.2.1.

A bearer-event-initiated Request of PCC Rules occurs when a new bearer is established or when an existing bearer is modified. For GPRS, these are PDP Context Modification(s) or secondary PDP context Activation(s). An IP-CAN Session modification triggers a PCC Rule request only if the PCRF has previously requested a PCC Rule request for the given modification event.

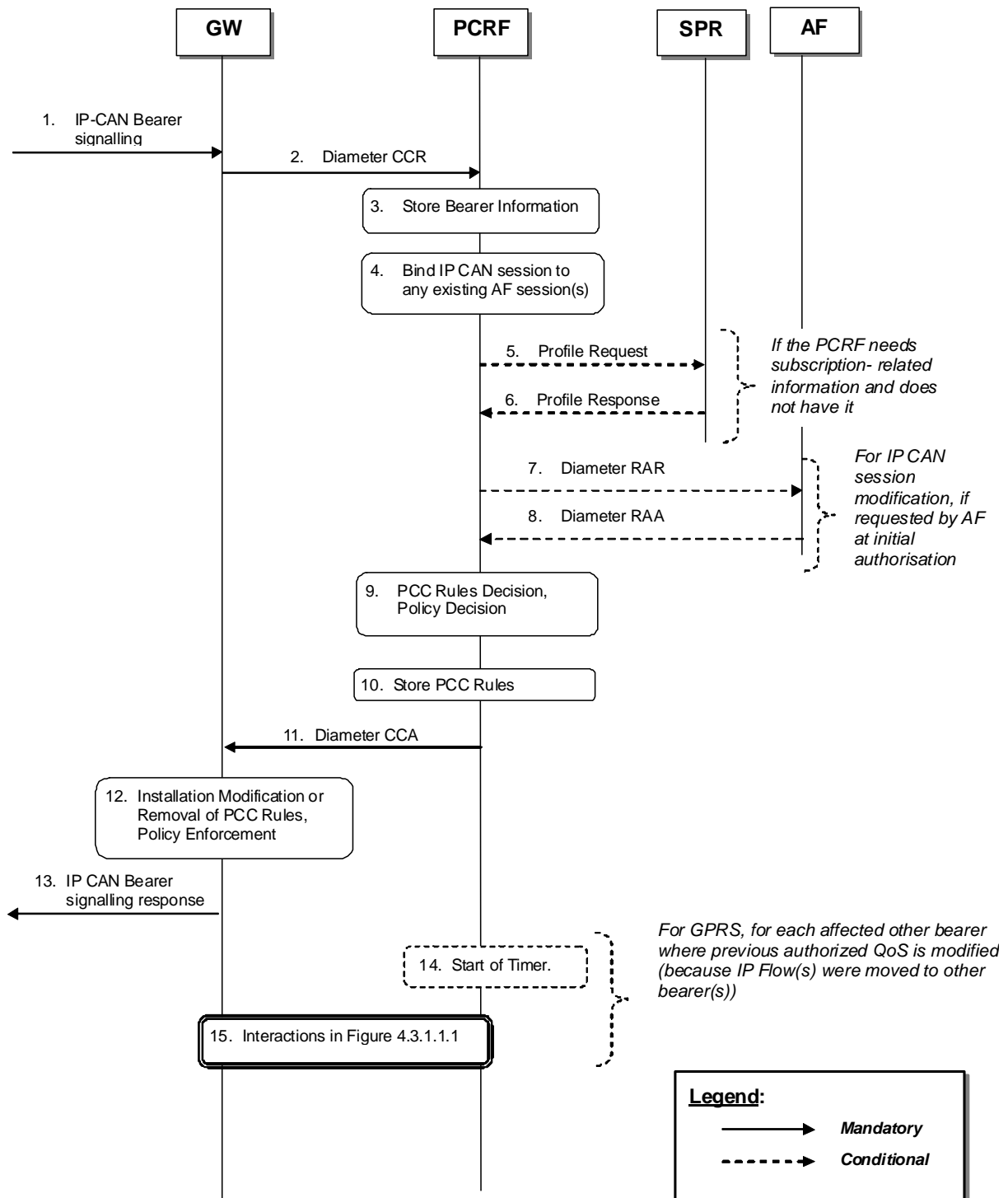

Figure D.3.1.2.1: UE-initiated IP-CAN Bearer Establishment and Modification.

1. The GW receives IP-CAN Bearer signalling that is a trigger for a PCC Rule request. For GPRS, the GGSN receives a secondary Establish PDP Context Request or an Update PDP Context Request.
2. The GW informs the PCRF of the modification of the IP-CAN Session due to the IP-CAN Bearer signalling in step 1, using a Diameter CCR with the CC-Request-Type AVP set to the value UPDATE_REQUEST. The GW reuses the existing Gx DCC session corresponding to the IP-CAN Session.

If the IP-CAN Bearer signalling in step 1 established a new IP-CAN Bearer, the GW assigns a new bearer identifier to this IP-CAN Bearer. The GW provides information about the new or modified bearer, e.g. requested QoS and TFT filters. If the event that caused the bearer modification applies uniquely to that bearer and PCRF performs the bearer binding, then, the bearer identifier should be provided within the CCR. If no bearer identifier is provided, the event trigger will apply to the IP-CAN session.

3. The PCRF stores the received information in the Diameter CCR.
4. The PCRF binds the IP-CAN Session to existing of AF session(s) using the information received from the GW and the Service Information included in the stored PCC rules, which was previously received from the AF(s) , as depicted in figure 4.3.1.1.1.
The PCRF also binds the IP-CAN Bearers within the IP-CAN Session to all matching IP flow(s) of existing AF session(s) using the bearer information received from the GW and the Service Information received from the AF(s). If IP flow(s), which have previously been bound to other bearers, have been bound to the modified bearer, PCC Rules in other bearer(s) may need to be removed. For GPRS, an IP flow may need to be removed if a matching higher priority TFT filter in the newly established PDP context takes precedence over a matching lower priority TFT filter in another PDP context. Furthermore, if IP Flow(s), which have previously been bound to the modified bearer are be bound to other bearer(s), PCC Rules may need to be installed in other bearers. For GPRS, an IP flow may be bound to another PDP context if it was previously bound to the modified PDP context due to a removed higher priority TFT filter, and a lower priority TFT filter in the other PDP context matches the IP flow.
5. If the PCRF requires subscription-related information and does not have it, the PCRF sends a request to the SPR in order to receive the information.
6. The SPR replies with the subscription related information containing the information about the allowed service(s) and PCC Rules information.

NOTE: For steps 5 and 6: The details associated with the Sp reference point are not specified in this Release. The SPR"s relation to existing subscriber databases is not specified in this Release.

7. For IP CAN session modification, if the AF requested a notification of the corresponding event at the initial authorisation of the AF session, the PCRF shall sent a Diameter RAR with the Specific-Action AVP set to indicate the trigger event that caused the request.
8. If step 7 happens, the AF replies with a Diameter RAA and may provide updated service information within.
9. The PCRF selects the new PCC Rule(s) to be installed. The PCRF can also identify existing PCC Rules that need to be modified or removed. The PCC Rules may relate to any of the matching AF sessions identified in step 4 or may exist in the PCRF without matching to any AF session. The PCRF may also make a policy decision by defining an authorized QoS and by deciding whether service flows described in the PCC Rules are to be enabled or disabled.
For types of IP-CAN, where the PCRF controls IP-CAN Bearers, e.g. GPRS, the PCC Rules may affect the IP-CAN Bearer identified in the CCR of step 2 or any other IP-CAN Bearer identified in step 4.
10. The PCRF stores the modified PCC Rules.
11. The PCC Rules are provisioned by the PCRF to the GW using Diameter CCA. The PCRF may also provide authorized QoS. The PCRF identifies the affected IP-CAN Bearer for each of the PCC Rules and the authorized QoS. The PCRF may provision PCC Rules and authorized QoS for several IP-CAN Bearers within the same CCA.
12. The GW installs the received PCC Rules. The GW also enforces the authorized QoS and enables or disables service flow according to the flow status of the corresponding PCC Rules.
13. The GW sends a response to the IP-CAN Bearer signalling in step 1.
For GPRS, the GGSN accepts the secondary Establish PDP Context Request or the Update PDP Context Request based on the results of the authorisation policy decision enforcement and sends an Establish PDP Context Response or Update PDP Context Response. If the requested QoS parameters do not correspond to the authorized QoS, the GGSN adjusts (downgrades/upgrades) the requested UMTS QoS parameters to the authorized values.

The PCRF may have decided in step 4 to modify PCC Rules and/or authorized QoS of other IP CAN bearers than the IP-CAN Bearer identified in the CCR of step 2. For each such other IP-CAN Bearer identified in step 4, the GGSN executes the following steps.
14. The PCRF may start a timer to wait for PDP context modification requests from the UE.
15. The PCRF interacts with the GW according to figure 4.3.1.1.1.

D.3.1.2.2 UE-initiated IP-CAN Bearer Termination

This clause is applicable if an IP-CAN Bearer is being released while other IP-CAN Bearers and thus the IP-CAN Session are not released.

For the termination of IP-CAN Bearers, three cases are covered:

- Bearer release that does not cause service data flow(s) within an AF session to be disabled;
- Bearer release that causes at least one but not all the service data flow(s) within an AF session to be disabled;
and
- Bearer release that causes all the service data flows within an AF session to be disabled.

A Bearer release may not cause a service data flow within this bearer to be disabled if the IP flow can be bound to another bearer. For GPRS, an IP flow can be bound to another PDP context if a lower precedence TFT filter matching the IP flow is installed at the other PDP context.

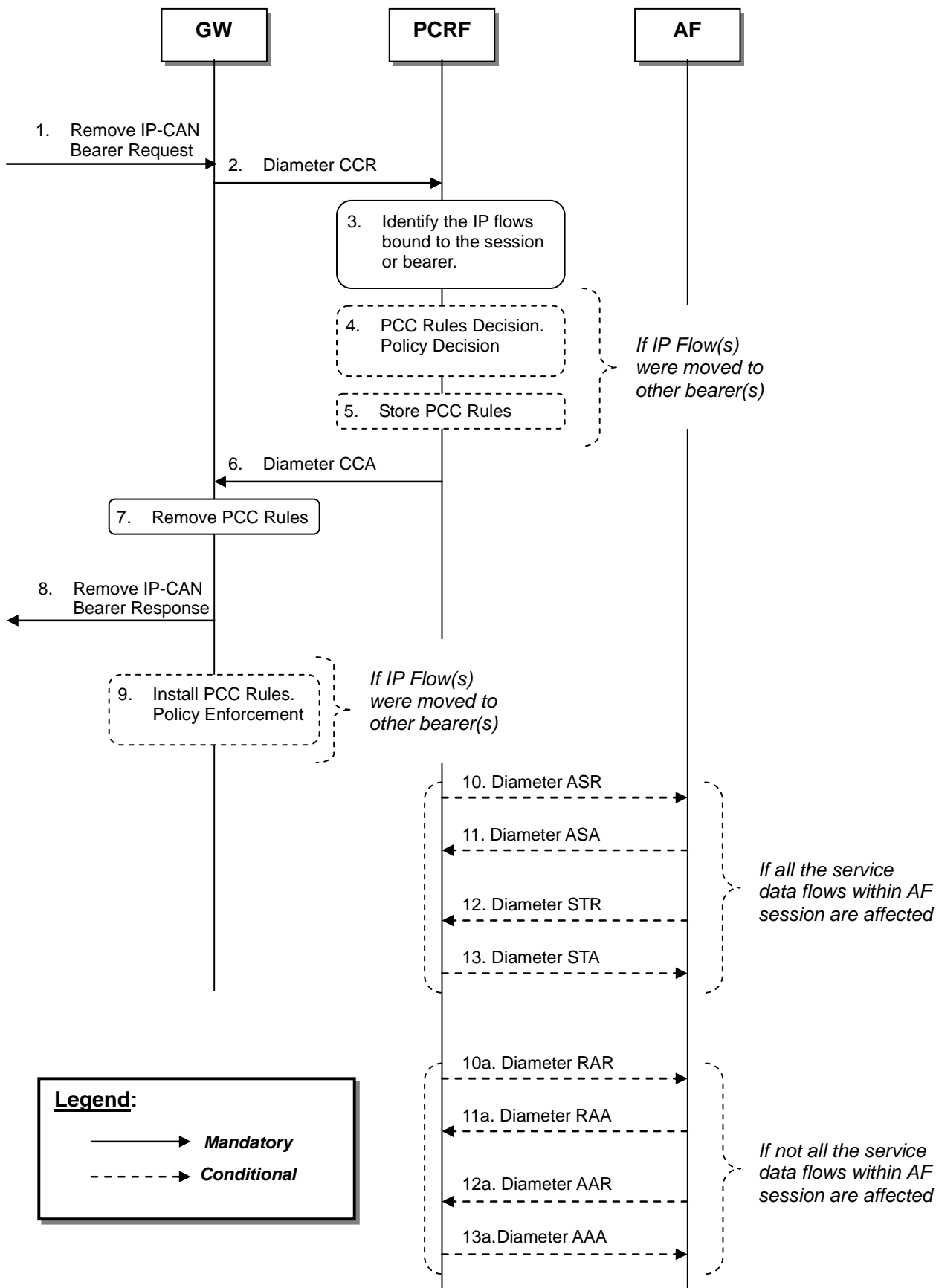

Figure D.3.1.2.2: UE-Initiated IP-CAN Bearer Termination

1. The GW receives a Remove IP-CAN Bearer Request that request the deactivation of an IP-CAN Bearer while other IP-CAN Bearers and thus the IP-CAN Session are not released. The form of the Remove IP-CAN Bearer Request depends upon the type of the IP-CAN. For GPRS, the GGSN receives a Delete PDP Context Request.
2. The GW sends a Diameter CCR message with the CC-Request-Type AVP set to the value UPDATE_REQUEST to the PCRF, indicating the IP-CAN Bearer termination.
3. The PCRF identifies the IP flows bound to the removed bearer and updates the stored bearer information. The PCRF re-evaluates the binding of IP flows, as IP flows may now be bound to other bearers. For GPRS, an IP flow may be bound to another PDP Context if it was previously bound to the removed PDP context due to a higher priority TFT filter, and a lower priority TFT filter in another PDP context matches the IP flow.

The following steps 4 and 5 are performed for each of the other bearers identified in step 3:

4. The PCRF selects the PCC Rule(s) to be installed or modified for the affected bearer. The PCRF may also update the policy decision for this bearer.
5. The PCRF stores the updated PCC Rules for the affected bearer.
6. The PCRF acknowledges the bearer termination by sending a Diameter CCA message. The PCRF provides PCC Rules and possibly updated authorized QoS for each of the other bearers identified in step 3. The PCRF identifies the affected IP-CAN Bearer for each of the PCC Rules and the authorized QoS.
7. The GW removes those PCC Rules, which have not been moved to other IP CAN bearers by the CCA message and are installed in the IP-CAN bearer, for which a termination has been requested in step 1.
8. The GW sends a Remove IP-CAN Bearer Response. For GPRS, the GGSN sends the Delete PDP Context Response message.
9. If the PCRF has provided PCC Rules and possibly updated authorized QoS for other bearers in step 6, the GW installs or modifies the identified PCC Rules. The GW also enforces the authorized QoS and enables or disables service flow according to the flow status of the corresponding PCC Rules.

The following steps 10 to 13 or 10a to 13a apply for the case where at least one IP Flow within an AF session is being disabled, i.e. if the IP Flow is not bound to any other bearer that is still established. The steps shall be performed separately for each ongoing AF session that is affected by the bearer release as explained below.

If all IP flow(s) within the AF session are disabled by the bearer release:

10. The PCRF indicates the session abort to the AF by sending a Diameter ASR message to the AF.
11. The AF responds by sending a Diameter ASA message to the PCRF.
12. The AF sends a Diameter STR message to the PCRF to indicate that the session has been terminated.
13. The PCRF responds by sending a Diameter STA message to the AF.

If at least one but not all of the IP flow(s) within the AF session are disabled by the bearer release, and the AF has requested notification of bearer removal:

- 10a. The PCRF indicates the release of the bearer by sending a Diameter RAR to the AF.
- 11a. The AF responds by sending a Diameter RAA to the PCRF.
- 12a. The AF may send an AAR to the PCRF to update the session information.
- 13a. If step 12a occurs, the PCRF responds by sending a AAA to the AF.

Annex E (informative): Change history

Date	TSG #	TSG Doc.	CR	Rev	Subject/Comment	Old	New
12/05/2006					Includes the following TDOCs agreed at CT3#40: C3-060287	0.0.0	0.1.0
13/09/2006					Includes the following TDOCs agreed at CT3#41: C3-060350	0.1.0	0.2.0
11/11/2006					Includes the following TDOCs agreed at CT3#42: C3-060694, C3-060754, C3-060807, C3-060867	0.2.0	0.3.0
01/12/2006	TSG#33	CP-060636			Editorial update by MCC for presentation to TSG CT for information	0.3.0	1.0.0
15/02/2007					Includes the following TDOCs agreed at CT3#42: C3-070059, C3-070060, C3-070138, C3-070180, C3-070182, C3-070237, C3-070248, C3-070252, C3-070269	1.0.0	1.1.0
28/02/2007	TSG#35	CP-070098			Editorial update by MCC for presentation to TSG CT for approval	1.1.0	2.0.0
03-2007					MCC update to version 7.0.0 after approval at TSG CT#35	2.0.0	7.0.0
06-2007	TSG#36	CP-070421	002	2	Timer handling for IP-CAN Session Modification initiated by the NW	7.0.0	7.1.0
06-2007	TSG#36	CP-070421	003	2	Duplicated Bearer Binding Text	7.0.0	7.1.0
06-2007	TSG#36	CP-070421	004	1	Alignment of PCRF Acknowledgment to AF	7.0.0	7.1.0
06-2007	TSG#36	CP-070421	005	4	QoS mapping corrections in 29.213	7.0.0	7.1.0
06-2007	TSG#36	CP-070421	006		Correction of IMS signal flows	7.0.0	7.1.0
06-2007	TSG#36	CP-070421	008	1	QoS mapping correction	7.0.0	7.1.0
06-2007	TSG#36	CP-070421	010	1	Various Minor Corrections	7.0.0	7.1.0
06-2007	TSG#36	CP-070421	011		Bearer Id in IP-CAN session Establishment	7.0.0	7.1.0
06-2007	TSG#36	CP-070421	013	2	Clarification on PCC Rule Provisioning Method	7.0.0	7.1.0
06-2007	TSG#36	CP-070421	014	4	QoS mapping clarifications for forking	7.0.0	7.1.0
06-2007	TSG#36	CP-070422	016	1	Maximum authorized data rate and bandwidth	7.0.0	7.1.0
06-2007	TSG#36	CP-070421	017	2	Mixed Mode	7.0.0	7.1.0
09-2007	TSG#37	CP-070557	021	2	Assigning IP address to UE	7.1.0	7.2.0
09-2007	TSG#37	CP-070557	023	2	Align Bearer Binding mechanism with stage 2	7.1.0	7.2.0
09-2007	TSG#37	CP-070557	024	2	Modification for the timer expiry in PUSH mode	7.1.0	7.2.0
09-2007	TSG#37	CP-070557	025	2	Reject IP-CAN session establishment	7.1.0	7.2.0
09-2007	TSG#37	CP-070675	026	3	QoS upgrading and GBR calculation	7.1.0	7.2.0
09-2007	TSG#37	CP-070557	027	1	QoS parameter mapping regardless the BCM	7.1.0	7.2.0
09-2007	TSG#37	CP-070557	028	1	QoS authorization per QCI	7.1.0	7.2.0
09-2007	TSG#37	CP-070557	029	1	Editor's Notes Removal	7.1.0	7.2.0
09-2007	TSG#37	CP-070557	030		Derivation of Flow-Description AVP when IPv4 is used	7.1.0	7.2.0
09-2007	TSG#37	CP-070557	033	1	IP-CAN bearer operation failure	7.1.0	7.2.0
09-2007	TSG#37	CP-070557	034	1	Corrections to IMS call flows for rejection of service change	7.1.0	7.2.0
09-2007	TSG#37	CP-070557	035	1	Correction of implementation error of CR0004, CR0005	7.1.0	7.2.0
12-2007	TSG#38	CP-070727	039	1	Fixing Mapping Tables	7.2.0	
			041	3	Addition of missing NAT procedures to PCC		7.3.0
12-2007					Correction to cover page	7.3.0	7.3.1
03-2008	TSG#39	CP-080040	043	1	PDP Session	7.3.1	7.4.0
05-2008	TSG#40	CP-080292	047	4	Support of TCP-based media in PCC	7.4.0	7.5.0
05-2008	TSG#40	CP-080298	046	3	Updating QoS mapping procedures for 3GPP2 IP-CAN	7.5.0	8.0.0
05-2008	TSG#40	CP-080299	049	2	TS 29.213 re-structuring	7.5.0	8.0.0
05-2008	TSG#40	CP-080299	053	3	Updates to Binding Mechanisms	7.5.0	8.0.0
09-2008	TSG#41	CP-080634	054	3	Roaming Scenarios on S9 for LBO case (HPLMN)	8.0.0	8.1.0
09-2008	TSG#41	CP-080634	055	4	Roaming Scenarios on S9 for LBO case (VPLMN)	8.0.0	8.1.0
09-2008	TSG#41	CP-080553	058	1	Removal of BCM=Nw-Only	8.0.0	8.1.0
09-2008	TSG#41	CP-080553	059	1	ARP Handling	8.0.0	8.1.0
09-2008	TSG#41	CP-080634	060	3	Gateway Control session Establishment Procedure	8.0.0	8.1.0
09-2008	TSG#41	CP-080634	061	2	IP-CAN Session Establishment flow description	8.0.0	8.1.0
09-2008	TSG#41	CP-080639	063	1	Remove unused reference	8.0.0	8.1.0
09-2008	TSG#41	CP-080634	064	1	Update to binding mechanisms	8.0.0	8.1.0
09-2008	TSG#41	CP-080634	065	3	Gateway control and QoS rules request flow	8.0.0	8.1.0
09-2008	TSG#41	CP-080634	066	3	Gateway control and QoS rules provision flow	8.0.0	8.1.0
09-2008	TSG#41	CP-080634	067	2	Gateway control session termination flow	8.0.0	8.1.0
09-2008	TSG#41	CP-080634	078	3	PDN information in Rx interface	8.0.0	8.1.0
09-2008	TSG#41	CP-080634	071	4	Update of UE-Initiated IP-CAN Session termination flow	8.0.0	8.1.0
09-2008	TSG#41	CP-080634	072	3	Update of GW-Initiated IP-CAN Session termination flow	8.0.0	8.1.0
09-2008	TSG#41	CP-080634	073	3	Update of PCRF-Initiated IP-CAN Session termination flow	8.0.0	8.1.0
09-2008	TSG#41	CP-080634	074	1	Update of the scope and references of 29.213	8.0.0	8.1.0
09-2008	TSG#41	CP-080634	076	2	General description for the DRA solutions	8.0.0	8.1.0
09-2008	TSG#41	CP-080553	079		Removal of the session information request from the PCRF to the	8.0.0	8.1.0

					AF		
09-2008	TSG#41	CP-080634	082	2	Applicability of QoS mapping functions	8.0.0	8.1.0
09-2008	TSG#41	CP-080655	096	1	Proxy DRA flows during IP-CAN session establishment	8.0.0	8.1.0
09-2008	TSG#41	CP-080656	097	2	Redirect DRA flows during IP-CAN session establishment/modification	8.0.0	8.1.0
09-2008	TSG#41	CP-080657	098	3	Redirect DRA flows during IP-CAN session termination	8.0.0	8.1.0
09-2008	TSG#41	CP-080645	099	2	DRA redirect procedures	8.0.0	8.1.0
09-2008	TSG#41	CP-080653	100	2	Proxy DRA flows during IP-CAN session modification	8.0.0	8.1.0
09-2008	TSG#41	CP-080654	101	2	Proxy DRA flows during IP-CAN session termination	8.0.0	8.1.0
10-2008					Editorial correction	8.1.0	8.1.1
12-2008	TSG#42	CP-080957	075	4	PCRF considerations for enhanced SDP	8.1.1	8.2.0
12-2008	TSG#42	CP-080758	102	5	Gx and Gxx session linking	8.1.1	8.2.0
12-2008	TSG#42	CP-080758	103	4	IP-CAN session establishment update	8.1.1	8.2.0
12-2008	TSG#42	CP-080921	104	2	PCRF selection in different scenarios	8.1.1	8.2.0
12-2008	TSG#42	CP-080758	107	2	IP-CAN session termination initiated by PCRF	8.1.1	8.2.0
12-2008	TSG#42	CP-080758	108	3	PCRF-initiated Gxx session termination	8.1.1	8.2.0
12-2008	TSG#42	CP-080921	110	4	PCRF Initiated Diameter session termination flows through redirect DRA(29.213)	8.1.1	8.2.0
12-2008	TSG#42	CP-080921	111	5	Diameter session establishment flows through proxy DRA via S9 reference point	8.1.1	8.2.0
12-2008	TSG#42	CP-080921	112	2	Diameter session modification flows through proxy DRA via S9 reference point	8.1.1	8.2.0
12-2008	TSG#42	CP-080921	113	5	PCRF Initiated Diameter session termination flows through Proxy DRA(29.213)	8.1.1	8.2.0
12-2008	TSG#42	CP-080758	115	3	Network-Initiated IP-CAN Session Modification Roaming Flow (Interactions between GW and PCRF)	8.1.1	8.2.0
12-2008	TSG#42	CP-080758	116	4	AF session modification call flow (AF in HPLMN)	8.1.1	8.2.0
12-2008	TSG#42	CP-080758	117	4	AF session modification call flow (AF in VPLMN)	8.1.1	8.2.0
12-2008	TSG#42	CP-080758	118	4	AF session termination call flow (AF in HPLMN)	8.1.1	8.2.0
12-2008	TSG#42	CP-080758	119	4	AF session termination call flow (AF in VPLMN)	8.1.1	8.2.0
12-2008	TSG#42	CP-080758	120	3	Update to Roaming call flows: AF in the Visited Network	8.1.1	8.2.0
12-2008	TSG#42	CP-080758	122	1	Fix errors in Gateway control and QoS rules request flow	8.1.1	8.2.0
12-2008	TSG#42	CP-080921	123	5	The redirect DRA flow during IP-CAN session modification	8.1.1	8.2.0
12-2008	TSG#42	CP-080921	124	1	Clarification of proxy DRA flows during diameter session termination	8.1.1	8.2.0
12-2008	TSG#42	CP-080921	125	1	Clarification of redirect DRA flow during diameter session termination	8.1.1	8.2.0
12-2008	TSG#42	CP-080758	134	1	QoS handling for non-GBR bearers	8.1.1	8.2.0
12-2008	TSG#42	CP-080758	136	1	IMS Flows for SAE	8.1.1	8.2.0
12-2008	TSG#42	CP-080758	137	1	Abbreviations update	8.1.1	8.2.0
12-2008	TSG#42	CP-080758	140	1	GW-initiated IP-CAN session termination update	8.1.1	8.2.0
03-2009	TSG#43	CP-090085	148	1	Clarification for the DRA binding	8.2.0	8.3.0
03-2009	TSG#43	CP-090096	150	3	IP-CAN Session Termination – Corrections and V-AF Support	8.2.0	8.3.0
03-2009	TSG#43	CP-090085	152	2	Clarify usage of Redirect-Host-Usage AVP	8.2.0	8.3.0
03-2009	TSG#43	CP-090085	154	1	Sending APN-AMBR and Default QoS parameters to the PCRF	8.2.0	8.3.0
03-2009	TSG#43	CP-090083	155	4	Multiple BBERF call flow	8.2.0	8.3.0
03-2009	TSG#43	CP-090085	157	2	Cleanup of interactions between PCRF, AF and SPR	8.2.0	8.3.0
03-2009	TSG#43	CP-090085	158	2	Cleanup of PCRF selection in the different scenarios	8.2.0	8.3.0
03-2009	TSG#43	CP-090085	159	2	Delete the editors notes in the clause of PCRF addressing	8.2.0	8.3.0
03-2009	TSG#43	CP-090085	160	2	The DRA flows for the roaming case	8.2.0	8.3.0
03-2009	TSG#43	CP-090085	161	2	Updating the IP address of UE to the redirect DRA for roaming case	8.2.0	8.3.0
03-2009	TSG#43	CP-090085	162	2	Clarification of diameter session termination	8.2.0	8.3.0
03-2009	TSG#43	CP-090085	166	1	Cleanup of IP-CAN session establishment	8.2.0	8.3.0
03-2009	TSG#43	CP-090096	167	1	IMS session setup with UE initiated resource reservation	8.2.0	8.3.0
03-2009	TSG#43	CP-090085	168	2	Gateway Control session	8.2.0	8.3.0
05-2009	TSG#44	CP-090346	169	1	ICS impact on PCC	8.3.0	8.4.0
05-2009	TSG#44	CP-090338	170	1	QoS per QCI	8.3.0	8.4.0
05-2009	TSG#44	CP-090338	172	3	PCEF Initiated IP CAN Session Modification - BBERF Switchover/Reclassification	8.3.0	8.4.0
05-2009	TSG#44	CP-090338	173	2	Bearer binding procedures update	8.3.0	8.4.0
05-2009	TSG#44	CP-090338	174	2	Supported BCM during gateway control session establishment	8.3.0	8.4.0
05-2009	TSG#44	CP-090338	175		Missing Step in Gateway Control session Establishment Procedure(29.213)	8.3.0	8.4.0
05-2009	TSG#44	CP-090338	176	5	Cleanup of IP-CAN session termination procedures	8.3.0	8.4.0
05-2009	TSG#44	CP-090338	177	1	Update of PCRF-initiated gateway control session termination	8.3.0	8.4.0
05-2009	TSG#44	CP-090338	178	5	Update of IP-CAN session establishment	8.3.0	8.4.0
05-2009	TSG#44	CP-090338	179	5	Update of gateway control session establishment	8.3.0	8.4.0
05-2009	TSG#44	CP-090338	180		Delete the Editors Note of establishment of Diameter Sessions for Non-roaming cases (Proxy DRA)	8.3.0	8.4.0
05-2009	TSG#44	CP-090338	181	2	Correction of the Termination of Diameter Sessions for Redirect DRA case procedure	8.3.0	8.4.0
09-2009	TSG#45	CP-090571	182	2	Deferred leg session linking handling	8.4.0	8.5.0

09-2009	TSG#45	CP-090571	183	2	ARP priority level values in intra-operator domain	8.4.0	8.5.0
09-2009	TSG#45	CP-090574	184	1	Bearer Control Mode handling in the flows	8.4.0	8.5.0
09-2009	TSG#45	CP-090574	192	2	Add the implementation of gateway control and QoS rules request for visited access	8.4.0	8.5.0
09-2009	TSG#45	CP-090574	194	2	General error-correction	8.4.0	8.5.0
09-2009	TSG#45	CP-090571	195	3	Handling of multiple BBERF about new gateway control session establishment for visited access	8.4.0	8.5.0
09-2009	TSG#45	CP-090571	196	4	Handling of multiple BBERF about PCEF-Initiated IP-CAN session modification for visited access	8.4.0	8.5.0
09-2009	TSG#45	CP-090574	197	1	Modification of PCRF-Initiated Gateway Control Session Termination procedure	8.4.0	8.5.0
09-2009	TSG#45	CP-090574	198	1	Modification of the description for the S2c case example in GC session procedures	8.4.0	8.5.0
09-2009	TSG#45	CP-090574	199	1	Modification of the S9 implementation of gateway control and QoS rules provision	8.4.0	8.5.0
09-2009	TSG#45	CP-090574	200	2	Modification of the S9 implementation of gateway control and QoS rules request	8.4.0	8.5.0
12-2009	TSG#46	CP-090841	206	2	ARP for the bearer binding	8.5.0	8.6.0
12-2009	TSG#46	CP-090841	211	1	Handling of Bearer Control Mode in roaming cases	8.5.0	8.6.0
12-2009	TSG#46	CP-090837	224	2	IMS Session Termination	8.5.0	8.6.0
12-2009	TSG#46	CP-090841	226	1	Correction to the BBERF-initiated gateway control session termination	8.5.0	8.6.0
12-2009	TSG#46	CP-090841	228	1	Correction to the scope of 29.213	8.5.0	8.6.0
12-2009	TSG#46	CP-090841	230	3	Deferred session linking handling in roaming scenario	8.5.0	8.6.0
12-2009	TSG#46	CP-090837	235	2	Clarification and correction of IPv6 call flows and procedures	8.5.0	8.6.0
12-2009	TSG#46	CP-090837	238	1	Small terminology correction in 29.213	8.5.0	8.6.0
12-2009	TSG#46	CP-090841	245	1	PCEF-Initiated IP-CAN session modification flows	8.5.0	8.6.0
12-2009	TSG#46	CP-090841	248	2	V-PCRF VPLMN Policy Enforcement Acceptable QoS Offer for HR	8.5.0	8.6.0
12-2009	TSG#46	CP-090841	250	4	V-PCRF VPLMN Policy Enforcement Acceptable QoS Offer for VA	8.5.0	8.6.0
12-2009	TSG#46	CP-090837	258	1	Correction to the Enabling of IP Flows in 29.213	8.5.0	8.6.0
03-2010	TSG#47	CP-100075	260		PCEF-Initiated IP-CAN session modification flows	8.6.0	8.7.0
03-2010	TSG#47	CP-100076	261	1	QoS derivation for 3GPP EPS with Gn/Gp SGSN	8.6.0	8.7.0
03-2010	TSG#47	CP-100075	264	2	PCEF-OCS Interaction	8.6.0	8.7.0
06-2010	TSG#48	CP-100308	269	1	Correction to the binding mechanism	8.7.0	8.8.0
09-2010	TSG#49	CP-100623	271	1	3GPP References to 3GPP2 specifications	8.8.0	8.9.0
09-2010	TSG#49	CP-100543	275	1	Sending the SDP offer to the terminating UE	8.8.0	8.9.0
09-2010	TSG#49	CP-100544	277	1	PCRF selection for case 2a	8.8.0	8.9.0
09-2010	TSG#49	CP-100544	279	1	QoS rule enforcement for gateway control session establishment	8.8.0	8.9.0
09-2010	TSG#49	CP-100544	283	1	Resolves some editors notes	8.8.0	8.9.0
09-2010	TSG#49				Editorial correction by MCC	8.9.0	8.9.1
12-2010	TSG#50	CP-100773	290	1	Correcting the call flow of multiple BBERF signalling in the visited access	8.9.1	8.10.0
12-2010	TSG#50	CP-100773	292	1	Correcting the call flow of Network-Initiated IP-CAN Session Modification	8.9.1	8.10.0
03-2011	TSG#51	CP-110106	312	1	Correct the description of Gateway Control session for case 2a	8.10.0	8.11.0
09-2011	TSG#53	CP-110608	328	1	Correction on DRA support for Rx interactions	8.11.0	8.12.0
09-2011	TSG#53	CP-110608	331		Support of speech SRVCC and the usage of QCI=1	8.11.0	8.12.0
09-2011	TSG#53	CP-110602	339	2	Fix reference to expired IETF ICE draft	8.11.0	8.12.0
09-2011	TSG#53	CP-110608	351		PCEF-initiated IP-CAN session modification step reference correction	8.11.0	8.12.0
12-2011	TSG#54	CP-110827	357		Correction in AVP names	8.12.0	8.13.0

History

Document history		
V8.0.0	November 2008	Publication
V8.1.1	November 2008	Publication
V8.2.0	January 2009	Publication
V8.3.0	April 2009	Publication
V8.4.0	June 2009	Publication
V8.5.0	October 2009	Publication
V8.6.0	January 2010	Publication
V8.7.0	April 2010	Publication
V8.8.0	June 2010	Publication
V8.9.1	October 2010	Publication
V8.10.0	January 2011	Publication
V8.11.0	April 2011	Publication
V8.12.0	October 2011	Publication
V8.13.0	January 2012	Publication