

# ETSI TS 129 232 V4.8.0 (2003-06)

---

*Technical Specification*

**Universal Mobile Telecommunications System (UMTS);  
Media Gateway Controller (MGC) -  
Media Gateway (MGW) interface;  
Stage 3  
(3GPP TS 29.232 version 4.8.0 Release 4)**

---



---

Reference

RTS/TSGN-0429232v480

---

Keywords

UMTS

**ETSI**

650 Route des Lucioles  
F-06921 Sophia Antipolis Cedex - FRANCE

Tel.: +33 4 92 94 42 00 Fax: +33 4 93 65 47 16

Siret N° 348 623 562 00017 - NAF 742 C  
Association à but non lucratif enregistrée à la  
Sous-Préfecture de Grasse (06) N° 7803/88

---

**Important notice**

Individual copies of the present document can be downloaded from:

<http://www.etsi.org>

The present document may be made available in more than one electronic version or in print. In any case of existing or perceived difference in contents between such versions, the reference version is the Portable Document Format (PDF). In case of dispute, the reference shall be the printing on ETSI printers of the PDF version kept on a specific network drive within ETSI Secretariat.

Users of the present document should be aware that the document may be subject to revision or change of status. Information on the current status of this and other ETSI documents is available at

<http://portal.etsi.org/tb/status/status.asp>

If you find errors in the present document, send your comment to:

[editor@etsi.org](mailto:editor@etsi.org)

---

**Copyright Notification**

No part may be reproduced except as authorized by written permission.  
The copyright and the foregoing restriction extend to reproduction in all media.

© European Telecommunications Standards Institute 2003.  
All rights reserved.

**DECT**<sup>TM</sup>, **PLUGTESTS**<sup>TM</sup> and **UMTS**<sup>TM</sup> are Trade Marks of ETSI registered for the benefit of its Members.  
**TIPHON**<sup>TM</sup> and the **TIPHON logo** are Trade Marks currently being registered by ETSI for the benefit of its Members.  
**3GPP**<sup>TM</sup> is a Trade Mark of ETSI registered for the benefit of its Members and of the 3GPP Organizational Partners.

---

## Intellectual Property Rights

IPRs essential or potentially essential to the present document may have been declared to ETSI. The information pertaining to these essential IPRs, if any, is publicly available for **ETSI members and non-members**, and can be found in ETSI SR 000 314: *"Intellectual Property Rights (IPRs); Essential, or potentially Essential, IPRs notified to ETSI in respect of ETSI standards"*, which is available from the ETSI Secretariat. Latest updates are available on the ETSI Web server (<http://webapp.etsi.org/IPR/home.asp>).

Pursuant to the ETSI IPR Policy, no investigation, including IPR searches, has been carried out by ETSI. No guarantee can be given as to the existence of other IPRs not referenced in ETSI SR 000 314 (or the updates on the ETSI Web server) which are, or may be, or may become, essential to the present document.

---

## Foreword

This Technical Specification (TS) has been produced by ETSI 3rd Generation Partnership Project (3GPP).

The present document may refer to technical specifications or reports using their 3GPP identities, UMTS identities or GSM identities. These should be interpreted as being references to the corresponding ETSI deliverables.

The cross reference between GSM, UMTS, 3GPP and ETSI identities can be found under <http://webapp.etsi.org/key/queryform.asp>.

# Contents

Intellectual Property Rights .....	2
Foreword.....	2
Foreword.....	6
1 Scope .....	7
2 References .....	7
3 Definitions, symbols and abbreviations .....	8
3.1 Definitions .....	8
3.2 Symbols.....	8
3.3 Abbreviations .....	8
4 UMTS capability set.....	8
5 Naming conventions.....	9
5.1 MGC/MGW naming conventions .....	9
5.2 Termination names .....	9
5.2.1 Termination naming convention .....	9
5.2.2 Termination naming convention for TDM terminations.....	10
6 Topology descriptor .....	10
7 Transaction timers .....	10
8 Transport .....	10
9 Multiple Virtual MG. ....	11
10 Formats and codes .....	11
11 Mandatory Support of SDP and H.248 Annex C information elements .....	11
12 General on packages.....	12
13 BICC packages.....	12
13.1 Mandatory BICC packages.....	12
13.2 Optional BICC packages .....	12
14 H.248 standard packages .....	12
14.1 Call independent H.248 transactions .....	12
14.1.1 MGW Out of service.....	13
14.1.2 MGW Communication Up.....	13
14.1.3 MGW Restoration.....	13
14.1.4 MGW Register.....	14
14.1.5 MGW Re-register .....	14
14.1.6 (G)MSC Server Ordered Re-register .....	14
14.1.7 (G)MSC Server Restoration.....	14
14.1.8 Termination Out-of-Service.....	14
14.1.9 Termination Restoration .....	14
14.1.10 Audit Value.....	15
14.1.11 Audit Capability.....	15
14.1.12 MGW Capability Change .....	15
14.1.13 (G)MSC Server Out of Service.....	15
14.2 Call related H.248 transactions.....	15
14.2.1 Change Flow Direction .....	16
14.2.2 Isolate Bearer Termination .....	17
14.2.3 Join Bearer Termination .....	17
14.2.4 Establish Bearer .....	17
14.2.5 Prepare Bearer .....	17
14.2.6 Change Through Connection .....	18

14.2.7	Activate Interworking Function .....	18
14.2.8	Release procedures .....	19
14.2.8.1	Release Bearer.....	19
14.2.8.2	Release Termination.....	19
14.2.9	Bearer Released .....	19
14.2.10	Bearer Established .....	19
14.2.11	Send Tone .....	19
14.2.12	Play Announcement .....	19
14.2.13	Send DTMF .....	19
14.2.14	Detect DTMF.....	20
14.2.15	Report DTMF .....	20
14.2.16	Announcement Completed .....	20
14.2.17	Activate Voice Processing Function .....	20
14.2.18	Reserve Circuit .....	20
14.2.19	Tunnel Information Up .....	21
14.2.20	Tunnel Information Down .....	21
14.2.21	Tone Completed.....	21
14.2.22	Stop Announcement.....	21
14.2.23	Stop Tone.....	21
14.2.24	Stop DTMF Detection .....	22
14.2.25	Stop DTMF.....	22
14.2.26	Confirm Char .....	22
14.2.27	Modify Char.....	22
14.2.28	Reserve Char.....	22
14.2.29	Bearer Modified.....	22
14.2.30	Bearer Modification Failed .....	22
14.2.31	TFO Activation .....	22
14.2.32	Optimal Codec and Distant List_Notify .....	23
14.2.33	Codec Modify .....	23
14.2.34	Distant Codec List .....	24
14.2.35	Command Rejected.....	24
14.2.36	Modify Bearer Characteristics .....	24
14.2.37	Protocol Negotiation Result .....	25
14.2.38	Rate Change.....	25
14.2.39	Bearer Modification Support .....	26
14.2.40	Reserve Bearer Characteristics .....	26
14.2.41	Confirm Bearer Characteristics.....	27
15	UMTS packages .....	27
15.1	Mandatory UMTS packages .....	27
15.1.1	3GUP package. ....	28
15.1.1.1	Properties .....	28
15.1.1.2	Events.....	30
15.1.1.3	Signals.....	30
15.1.1.4	Statistics .....	30
15.1.1.5	Procedures.....	30
15.1.2	Circuit Switched Data package.....	32
15.1.2.1	Properties .....	32
15.1.2.2	Events.....	32
15.1.2.3	Signals.....	33
15.1.2.4	Statistics .....	34
15.1.2.5	Procedures.....	34
15.1.3	TFO package.....	34
15.1.3.1	Properties .....	34
15.1.3.2	Events.....	35
15.1.3.3	Signals.....	36
15.1.3.4	Statistics .....	36
15.1.3.5	Procedures.....	36
15.1.4	3G Expanded Call Progress Tones Generator Package .....	36
15.1.4.1	Properties .....	36
15.1.4.2	Events.....	36
15.1.4.3	Signals.....	36

15.1.4.4	Statistics .....	37
15.1.4.5	Procedures .....	37
15.1.5	Modification Of Link Characteristics Bearer Capability .....	37
15.1.5.1	Properties .....	37
15.1.5.2	Events .....	37
15.1.5.3	Signals .....	38
15.1.5.4	Statistics .....	38
15.1.5.5	Procedures .....	38
15.1.6	Void .....	38
15.1.7	Enhanced Circuit Switched Data package .....	38
15.1.7.1	Properties .....	38
15.1.7.2	Events .....	38
15.1.7.3	Signals .....	38
15.1.7.4	Statistics .....	39
15.1.7.5	Procedures .....	39
15.2	Optional UMTS packages .....	39
<b>Annex A (informative): The Framing protocol Interworking Function (FPIF) .....</b>		<b>40</b>
A.1	Introduction .....	40
A.2	FPIF procedures with respect to Iu framing protocol .....	40
A.2.1	Payload .....	41
A.2.2	RFCIs .....	41
A.2.3	FQC .....	41
A.2.4	Frame number .....	41
A.3	Relay of status information .....	41
A.3.1	Void .....	41
A.3.2	Rate Control Frames .....	41
A.3.2	Time Alignment .....	42
<b>Annex B (informative): Examples for Usage of the 3GUP Package “Initialisation Direction” Property .....</b>		<b>42</b>
<b>Annex C (informative): Change history .....</b>		<b>44</b>
History .....		45

---

# Foreword

This Technical Specification has been produced by the 3<sup>rd</sup> Generation Partnership Project (3GPP).

The contents of the present document are subject to continuing work within the TSG and may change following formal TSG approval. Should the TSG modify the contents of the present document, it will be re-released by the TSG with an identifying change of release date and an increase in version number as follows:

Version x.y.z

where:

- x the first digit:
  - 1 presented to TSG for information;
  - 2 presented to TSG for approval;
  - 3 or greater indicates TSG approved document under change control.
- y the second digit is incremented for all changes of substance, i.e. technical enhancements, corrections, updates, etc.
- z the third digit is incremented when editorial only changes have been incorporated in the document.

---

# 1 Scope

The present document describes the protocol to be used on the Media Gateway Controller (MGC) – Media Gateway (MGW) interface. The Media Gateway Controllers covered in this specification are the MSC server and the GMSC server. The basis for this protocol is the H.248/MEGACO protocol as specified in ITU-T and IETF. The BICC architecture as described in 3GPP TS 23.205 [2] and 3GPP 29.205 [7] defines the usage of this protocol.

This specification describes the changes to H.248/MEGACO which are needed to handle 3GPP specific traffic cases. This is done by using the H.248/MEGACO standard extension mechanism.

The present document is valid for a 3<sup>rd</sup> generation PLMN (UMTS) complying with Release 4 and later.

---

# 2 References

The following documents contain provisions which, through reference in this text, constitute provisions of the present document.

- References are either specific (identified by date of publication, edition number, version number, etc.) or non-specific.
- For a specific reference, subsequent revisions do not apply.
- For a non-specific reference, the latest version applies. In the case of a reference to a 3GPP document (including a GSM document), a non-specific reference implicitly refers to the latest version of that document *in the same Release as the present document*.

- [1] 3GPP TS 23.153: "3rd Generation Partnership Project; Technical Specification Group Core Network; Out of Band Transcoder Control - Stage 2"
- [2] 3GPP TS 23.205: "3rd Generation Partnership Project; Technical Specification Group Core Network; Bearer Independent CS Core Network – Stage 2"
- [3] 3GPP TS 24.008: "3rd Generation Partnership Project; Technical Specification Group Core Network; Mobile radio interface layer 3 specification"
- [4] 3GPP TS 25.415: "3rd Generation Partnership Project; Technical Specification Group Radio Access Network; UTRAN Iu interface user plane protocols".
- [5] 3GPP TS 28.062: "3rd Generation Partnership Project; Technical Specification Group Services & System Aspects; In-band Tandem Free Operation (TFO) of Speech Codecs; Stage 3 – Service Description"
- [6] 3GPP TS 29.007: "3rd Generation Partnership Project; Technical Specification Group Core Network; General requirements on interworking between the Public Land Mobile Network (PLMN) and the Integrated Services Digital Network (ISDN) or Public Switched Telephone Network (PSTN)"
- [7] 3GPP TS 29.205: "3rd Generation Partnership Project; Technical Specification Group Core Network; Application of Q.1900 series to Bearer Independent CS Network architecture; Stage 3"
- [8] 3GPP TS 29.415: "3rd Generation Partnership Project; Technical Specification Group Core Network; CN Nb interface user plane protocols".
- [9] 3GPP TS 48.008: "3rd Generation Partnership Project; Technical Specification Group GSM EDGE Radio Access Network; Mobile-services Switching Centre - Base Station System (MSC - BSS) interface; Layer 3 specification".
- [10] ITU-T Recommendation H.248 (06/00): "Media Gateway Control Protocol"
- [11] ITU-T Recommendation Q.2210 (07/96): "Message transfer part level 3 functions and messages using the services of ITU-T Recommendation Q.2140"



- [12] RFC 2960 "Stream Control Transmission Protocol"
- [13] 3G TS 29.202: "SS7 signalling transport in core network"
- [14] ITU-U Recommendation H.248 Annex L, "Error Codes and Service Change Reason Description"
- [15] 3GPP TS 23.014: "Technical Specification Group Core Network; Support of Dual Tone Multi-Frequency (DTMF) signalling".

## 3 Definitions, symbols and abbreviations

### 3.1 Definitions

For the purposes of the present document, the following terms and definitions apply.

**Context (H.248):** A context is an association between a number of Terminations. The context describes the topology (who hears/sees whom) and the media mixing and/or switching parameters if more than two terminations are involved in the association.

**Package (H.248):** Different types of gateways may implement terminations which have differing characteristics. Variations in terminations are accommodated in the protocol by allowing terminations to have optional properties. Such options are grouped into packages, and a termination may realise a set of such packages.

**Termination (H.248):** A termination is a logical entity on an MGW which is the source and/or sink of media and/or control streams. A termination is described by a number of characterising properties, which are grouped in a set of descriptors which are included in commands. Each termination has a unique identity (TerminationID).

**Termination Property (H.248):** Termination properties are used to describe terminations. Related properties are grouped into descriptors. Each termination property has a unique identity (PropertyID).

### 3.2 Symbols

For the purposes of the present document, the following symbols apply:

Iu	Interface between the RNS and the core network. It is also considered as a reference point.
Mc	Interface between the server and the media gateway.

### 3.3 Abbreviations

For the purposes of the present document, the following abbreviations apply:

BICC	Bearer Independent Call Control
MGC	Media Gateway Controller
MTP3	Message Transfer Part layer 3
RFC	Request For Comment; this includes both discussion documents and specifications in the IETF domain
SCTP	Stream Control Transmission Protocol
TFO	Tandem Free Operation
TrFO	Transcoder Free Operation
M3UA	SS7 MTP3 – User Adaptation Layer

## 4 UMTS capability set

This capability set shall be used in its entirety whenever it is used within an H.248 profile. Failure to do so will result in a non-standard implementation.

ITU-T Recommendation H.248 version 1 (06/00) [10] is supported by this Capability Set. The compatibility rules for packages, signals, events, properties and statistics and the H.248 protocol are defined in ITU-T Recommendation H.248 [10].

## 5 Naming conventions

### 5.1 MGC/MGW naming conventions

The MGC shall be named according to the naming structure of the underlying transport protocol which carries the H.248 protocol.

### 5.2 Termination names

The Termination ID structure shall follow the guidelines of H.248 and the structure is either relevant or irrelevant for MGC and MGW.

The relevance depends on the utilized bearer type for termination. With ephemeral ATM/AAL2 and IP endpoint bearer types the internal structure of Termination ID is irrelevant for MGW and MGC and therefore Termination ID is only numeric identifier for termination. When bearer type is physical timeslot within TDM circuit the Termination ID structure shall follow the Termination naming convention for TDM circuit bearer.

#### 5.2.1 Termination naming convention

The following general structure of termination ID shall be used:

##### ASN.1 coding:

4 octets shall be used for the termination ID. The following defines the general structure for the termination ID:

Termination type	X
------------------	---

Termination type:

Length 3 bits

Values:

000 Reserved

001 Ephemeral termination

010 TDM termination

011 - 110 Reserved

111 Reserved for ROOT termination Id

X:

Length 29 bits.

Usage dependent on Termination type. TDM terminations specified below in chapter 5.2.2. Other usage unspecified.

##### **ABNF coding:**

TerminationID = "ROOT" / pathName / "\$" / "\*" ; According to H.248 Annex B

With ephemeral termination:

pathName = EphTokenUNDERSCORE(EPHsystem/"\*")

EphToken = "Ephemeral"

UNDERSCORE = %x5F ;"\_"

EPHsystem : Usage is not specified

## 5.2.2 Termination naming convention for TDM terminations

### ASN.1 coding:

Termination type (=010 )	PCM system	Individual
--------------------------	------------	------------

PCM system:

Length 24 bits.

Usage unspecified. Uniquely identifies PCM interface in MGw

Individual:

Length: 5 bits

Max. of 32 individuals (timeslots) per PCM system (max. 24 for a 24 channel system)

### ABNF coding:

pathName = TDMTToken UNDERSCORE ((PCMsystem / "\*") SLASH (Individual / "\*"))

TDMTToken = "TDM"

UNDERSCORE = %x5F ;"\_"

PCMsystem : Usage not specified

Individual = 1 \* 2 (DIGIT) ; 0-31

## 6 Topology descriptor

The Topology Descriptor shall be supported by the MGW and MGC for handover and lawful interception.

## 7 Transaction timers

All transaction timers specified in H.248 shall be supported in this subset of the protocol.

## 8 Transport

Each implementation of the Mc interface should provide the appropriate protocol options: MTP3B as defined in ITU—T Recommendation Q.2210 [11] (for ATM signalling transport) or SCTP as defined in RFC2960 [12] (for IP signalling transport) and in the case where the signalling relation consists of both ATM signalling transport and IP signalling transport the M3UA protocol layer [13] shall be added to SCTP to provide interworking. M3UA layer may also be added to SCTP for pure IP signalling transport. In summary:

- 1) For pure IP connections, H.248/SCTP/IP should be used. In addition, to allow for flexible implementations of gateways and controllers in order to offer efficient use of SCTP associations the M3UA layer may also be added on top of SCTP.
- 2) For pure ATM connections, H.248/MTP3b/SSCF/SSCOP/AAL5/ATM should be used,
- 3) For mixed IP&ATM connections, H.248/M3UA/SCTP/IP shall be used as the IP transport.

## 9 Multiple Virtual MG.

If an MGW is connected to more than one (G)MSC, the MGW shall fulfil the requirements outlined in the section "Multiple virtual MGW" in ITU-T Recommendation H.248 [10]

## 10 Formats and codes

Table 1 shows the parameters which are required, in addition to those defined in the subclause "Formats and Codes" of ITU—T Recommendation Q.1950 (see 3GPP TS 29.205 [7]).

The coding rules applied in ITU-T Recommendation H.248 [10] for the applicable coding technique shall be followed for the UMTS capability set.

**Table 1: Additional parameters required**

actprot	Signal descriptor	As for the signal "Activate protocol" in subclause 15.1.2.3
Mode	Local control	As for the property "UP mode of operation" in subclause 15.1.1.1
Version	Local control	As for the property "Upversion" in subclause 15.1.1.1
Value	Local control	As for the property " Delivery of erroneous SDUs" in subclause 15.1.1.1
Interface	Local control	As for the property " Interface" in subclause 15.1.1.1
Initdirection	Local control	As for the property " Initialisation Direction" in subclause 15.1.1.1
PLMN bearer capability	Local control	As for the property "PLMN BC" in subclause 15.1.2.1
Coding	Local control	As for the property " GSM channel coding" in subclause 15.1.2.1
Tfoenable	Local control	As for the property " TFO activity control" in subclause 15.1.3.1
Codeclist	Local control	As for the property " TFO Codec List" in subclause 15.1.3.1
Result	ObservedEvent descriptor	As for the ObservedEventDescriptor parameter "Protocol Negotiation Result" in subclause 15.1.2.2
Cause	ObservedEvent descriptor	As for the ObservedEventDescriptor parameter "Protocol Negotiation Result" in subclause 15.1.2.2
Rate	ObservedEvent descriptor	As for the ObservedEventDescriptor parameter "Rate Change" in subclause 15.1.2.2
Optimalcodec	ObservedEvent descriptor	As for the ObservedEventDescriptor parameter "Optimal Codec Type" in subclause 15.1.3.2
Distlist	ObservedEvent descriptor	As for the ObservedEventDescriptor parameter "Distant TFO List" in subclause 15.1.3.2
Off / value	Local control	As for the property "Echo cancelling" in subclause E.13.1 in ITU-T Recommendation H.248 [10]
Error	Error descriptor	As defined in the subclause "Command error code" in ITU-T Recommendation H.248 [10]
Bearer Modification Support	EventDescriptor	As for the EventsDescriptor in "Bearer Modification Support" in subclause 15.1.4.2.
Bearer modification possible	ObservedEvent descriptor	As for the ObservedEventDescriptor in "Bearer Modification Support" in subclause 15.1.4.2.
Bitrate	Local control	As for the property " Bitrate" in subclause 15.1.7.1

## 11 Mandatory Support of SDP and H.248 Annex C information elements

This section shall be in accordance with the subclause "Mandatory Support of SDP and H.248 Annex C information elements" in ITU-T Recommendation Q.1950 (see 3GPP TS 29.205 [7]).

---

## 12 General on packages

## 13 BICC packages

### 13.1 Mandatory BICC packages

The following BICC packages shall be supported:

- Bearer Characteristics Package (see ITU-T Recommendation Q.1950 Annex A.3);
- Bearer Network Connection Cut Through Package (see ITU-T Recommendation Q.1950 Annex A.4);
- Generic Bearer Connection Package (see ITU-T Recommendation Q.1950 Annex A.6).

### 13.2 Optional BICC packages

The following BICC packages shall be supported as required by the network services deployed in the network:

- Basic Call Progress Tones Generator with Directionality, (-see ITU-T Recommendation Q.1950 Annex A.8)
- Expanded Call Progress tones Generator Package ( -see ITU-T Recommendation Q.1950 Annex A.9)
- Basic Services Tones Generation Package, (-s ee ITU-T Recommendation Q.1950 Annex A.10)
- Bearer Control Tunnelling Package (see ITU-T Recommendation Q.1950 Annex A.7);
- Expanded Services Tones Generation Package (see ITU-T Recommendation Q.1950 Annex A.11);
- Intrusion Tones Generation Package (see ITU-T Recommendation Q.1950 Annex A.12);
- Business Tones Generation Package (see ITU-T Recommendation Q.1950 Annex A.13).

---

## 14 H.248 standard packages

The following H.248 packages are used by this UMTS Capability Set:

- Generic v1 (see [10] Annex E.1);
- Base Root Package v1 (see [10] Annex E.2);
- Tone Generator Package v1 (see [10] Annex E.3);
- Tone Detection Package v1 (see [10] Annex E.4);
- Basic DTMF Generator Package v1 (see [10] Annex E.5);
- DTMF Detection Package v1 (see [10] Annex E.6);
- Call Progress Tones Generator Package v1 (see [10] Annex E.7);
- Generic Announcement Package v1 (see [10] Annex K);
- TDM Circuit Package v1 (see [10] Annex E.13).

### 14.1 Call independent H.248 transactions

Table 2 shows the relationship between each non call-related procedure in ITU-T Recommendation Q.1950 (see 3GPP TS 29.205 [7]) and the corresponding stage 2 procedure defined in 3GPP TS 23.205 [2].

For further description of error codes and service change reasons, refer to [14].

**Table 2: Correspondence between Q.1950 non call-related transactions and TS 23.205 procedures**

Transaction used in Q.1950	Procedure defined in 3GPP TS 23.205 [2]	Comments
BIWF_Service_Cancellation_Indication	MGW Out of Service	
BIWF_Lost_Communication	MGW Communication Up	
BIWF_Service_Restoration_Indication	MGW Restoration	
BIWF_Registration	MGW Register	
BIWF_Re-Registration	MGW Re-register	
CCU Ordered BIWF Re-Registration	(G)MSC Server Ordered Re-register	
CCU Initiated Service Restoration	(G)MSC Server Restoration	
CCU Initiated Service Cancellation	(G)MSC Server Out of Service	
BIWF_Service_Cancellation_Indication	Termination Out-of-Service	Is a part of BIWF Service cancellation in Q.1950
BIWF_Service_Restoration_Indication	Termination Restoration	Is a part of BIWF Service cancellation in Q.1950
Audit_Values	Audit Value	
Audit_Capabilities	Audit Capability	
BIWF_Capability_Change	Capability Update	

### 14.1.1 MGW Out of service

This procedure is the same as described in the subclause "BIWF Service Cancellation Indication" in ITU-T Recommendation Q.1950 (see 3GPP TS 29.205 [7]), with the following clarification.

Address Information	Control information	Bearer information
	Transaction ID = z Context ID = Null Termination ID = Root Service Change Reason = MGW impending failure Service Change Method = Graceful / Forced	

Delay is not used.

### 14.1.2 MGW Communication Up

This procedure is the same as described in the subclause "BIWF Lost Communication" in ITU-T Recommendation Q.1950 (see 3GPP TS 29.205 [7]).

### 14.1.3 MGW Restoration

This procedure is the same as described in the subclause "BIWF Service Restoration Indication" in ITU-T Recommendation Q.1950 (see 3GPP TS 29.205 [7]) with the following clarification.

Address Information	Control information	Bearer information
	Transaction ID = z Context ID = Null Termination ID = Root	

Delay is not used.

### 14.1.4 MGW Register

This procedure is the same as that described in the subclause "BIWF Registration" in ITU-T Recommendation Q.1950 (see 3GPP TS 29.205 [7]).

### 14.1.5 MGW Re-register

This procedure is the same as that described in the subclause "BIWF Re-Registration" in ITU-T Recommendation Q.1950 (see 3GPP TS 29.205 [7]).

### 14.1.6 (G)MSC Server Ordered Re-register

This procedure is the same as described in the subclause "CCU Ordered BIWF Re-registration" in ITU-T Recommendation Q.1950 (see 3GPP TS 29.205 [7]).

### 14.1.7 (G)MSC Server Restoration

This procedure is the same as described in the subclause "CCU Initiated Service Restoration" in ITU-T Recommendation Q.1950 (see 3GPP TS 29.205 [7]) with the following clarification.

Address Information	Control information	Bearer information
	Context ID = Null Termination ID = Root Service Change Reason = Cold Boot / Warm Boot Service Change Method = Restart	

Delay is not used.

### 14.1.8 Termination Out-of-Service

This procedure is the same as described in the subclause "BIWF Service Cancellation Indication" in ITU-T Recommendation Q.1950 (see 3GPP TS 29.205 [7]) with the following clarification.

ServiceChange.req (Termination Out-of-Service)

MGW to MGC

Address Information	Control information	Bearer information
	Transaction ID = z Context ID = Contexts / Null / All Termination ID = Termination(s) Service Change Reason = Transmission failure / Termination malfunctioning / Loss of lower layer connectivity / Termination taken out of service Service Change Method = Graceful / Forced	

Delay is not used.

### 14.1.9 Termination Restoration

This procedure is the same as described in the subclause "BIWF Service Restoration Indication" in ITU-T Recommendation Q.1950 (see 3GPP TS 29.205 [7]).

Address information	Control information	Bearer information
	Transaction ID = z Context ID = Contexts / Null / All Termination ID = Termination(s) Service Change Reason = Service Restored Service Change Method = Restart	

### 14.1.10 Audit Value

This procedure is the same as described in the subclause "Audit Values" in ITU-T Recommendation Q.1950 (see 3GPP TS 29.205 [7]).

### 14.1.11 Audit Capability

This procedure is the same as described in the subclause "Audit Capabilities" in ITU-T Recommendation Q.1950 (see 3GPP TS 29.205 [7]).

### 14.1.12 MGW Capability Change

This procedure is the same as described in the subclause "BIWF Capability Change" in ITU-T Recommendation Q.1950 (see 3GPP TS 29.205 [7]).

### 14.1.13 (G)MSC Server Out of Service

This procedure is the same as that described in the subclause "CCU Initiated Service Cancellation" in ITU-T Recommendation Q.1950 (see 3GPP TS 29.205 [7]).

## 14.2 Call related H.248 transactions

Table 3 shows the relationship between each call-related procedure in ITU-T Recommendation Q.1950 (see 3GPP TS 29.205 [7]) and the corresponding stage 2 procedure defined in 3GPP TS 23.205 [2].



**Table 3: Correspondence between Q.1950 call-related transactions and 3GPP TS 23.205 and 23.153 procedures**

Transaction used in Q.1950	Procedure defined in 3GPP TS 23.205 [2] and 23.153 [1]	Comments
Change_Topology	Change Flow Direction	
Join	Join Bearer Termination	
Isolate	Isolate Bearer Termination	
Establish_BNC_Notify+(tunnel)	Establish Bearer	
Prepare_BNC_Notify+(tunnel)	Prepare Bearer	
Cut_Through	Change Through-Connection	
Not defined in Q.1950	Activate Interworking Function	
Cut_BNC (include several procedures).	Release Bearer (Release Bearer and Release termination)	
BNC Established	Bearer Established	
BNC Release	Bearer Released	
Insert_Tone	Send Tone	
Insert_Announcement	Play Announcement	
Signal Completion	Announcement Completed	
Detect_Digit	Detect DTMF	
Insert_Digit	Send DTMF	
Detected digit(BIWF)	Report DTMF	
Confirm_Char	Confirm Char	
Modify_Char	Modify Char	
Reserve_Char_Notify	Reserve Char	
BNC Modified	Bearer Modified	
Echo Canceller	Activate Voice Processing Function	
BNC Connected	<b>[Editors note: No definition yet]</b>	
BNC Modification failure	Bearer Modified Failed	
Tunnel (MGC-MGW)	Tunnel Information Down	
Tunnel (MGW-MGC)	Tunnel Information Up	
Insert Tone	Stop Tone	
Insert Announcement	Stop Announcement	
Detect Digits	Stop DTMF Detection	
Insert Digit	Stop DTMF	
Signal.Completion	Tone Completed	
Not defined	Reserve Circuit	
Not defined	Command Rejected	
Not defined	TFO Activation	
Not defined	Codec_Modify	
Not defined	Optimal Codec and Distant List_Notify	
Not defined	Distant Codec List	
Modify Char	Modify Bearer Characteristics	
Not defined	IWF Protocol Indication	
Not defined	Bearer Modification Support	

NOTE: A procedure defined in table 3 can be combined with another procedure in the same action. This means that they can share the same contextID and termination ID(s).

### 14.2.1 Change Flow Direction

This procedure is the same as that defined in the subclause "Change Connection Topology" in ITU-T Recommendation Q.1950 (see 3GPP TS 29.205 [7]) with the following additions.

Address Information	Control information	Bearer information
	Context ID = c1,? Connection Configuration = (TerminationID= x1, ? TerminationID=x2,? [type = x]),...	

### 14.2.2 Isolate Bearer Termination

This procedure is the same as that defined in the subclause "Isolate" in ITU-T Recommendation Q.1950 (see 3GPP TS 29.205 [7]).

### 14.2.3 Join Bearer Termination

This procedure is the same as that defined in the subclause "Join" in Q.1950 (see 3GPP TS 29.205 [7]).

### 14.2.4 Establish Bearer

This procedure is the same as that defined in the subclause "Establish BNC\_notify" in ITU-T Recommendation Q.1950 (see 3GPP TS 29.205 [7]) with additions as shown below.

Address Information	Control information	Bearer information
	UP mode = Mode UP version = version Delivery of erroneous SDUs = value Interface = interface Initdirection = initdirection Bitrate = bitrate  If indication on Protocol Negotiation Result requested: NotificationRequested (Event ID = x, "Prot Negotiation Result")  If indication on Rate Change requested: NotificationRequested (Event ID = x, "RateChange")	PLMN bearer capability = PLMN capability  GSM channel coding = coding

The parameter logical port is not used.

### 14.2.5 Prepare Bearer

This procedure is the same as that defined in the subclause "Prepare\_BNC\_notify" in ITU-T Recommendation Q.1950 (see 3GPP TS 29.205 [7]) with additions as shown below:

Address Information	Control information	Bearer information
	UP mode = mode UP version = version Delivery of erroneous SDUs = value Interface = interface Initdirection = initdirection Bitrate = bitrate  If indication on Protocol Negotiation Result requested: NotificationRequested (Event ID = x, "Prot Negotiation Result")  If indication on Rate Change requested: NotificationRequested (Event ID = x, "RateChange")  If indication on Bearer Modification requested: NotificationRequested (Event ID = x, "Bearer Modification Support")	PLMN bearer capability = PLMN capability  GSM channel coding = coding

The parameter logical port is not used.

### 14.2.6 Change Through Connection

This procedure is the same as that defined in the subclause "Cut Through" in ITU-T Recommendation Q.1950 (see 3GPP TS 29.205 [7]) with the following clarification and deletion.

The BIWF controlled cut through, as defined in the subclause "Cut Through" - "BIWF controlled" in ITU-T Recommendation Q.1950 (see 3GPP TS 29.205 [7]), is used as well as the MGC controlled cut through for the change through connection procedure.

NotificationRequested = (Event ID = x, "Cut Through") is deleted.

### 14.2.7 Activate Interworking Function

When the procedure "Activate Interworking Function" is required the following procedure is initiated:

The MGC sends a MOD.req command with the following information.

1 MOD.req (Activate Interworking function) MGC to MGW

Address Information	Control information	Bearer information
	Transaction ID = z Context ID = c1 Termination ID = bearer1  Signal=actpro  If indication on Protocol Negotiation Result requested: NotificationRequested (Event ID = x, "Prot Negotiation Result")  If indication on Rate Change requested: NotificationRequested (Event ID = x, "RateChange")	

When the processing of command (1) is complete, the MGW initiates the following procedure.

2 MOD.resp (Activate Interworking function) MGW to MGC

Address Information	Control information	Bearer information
	Transaction ID = z Context ID = c1 TerminationID = bearer1	

## 14.2.8 Release procedures

This subclause includes a number of procedures.

### 14.2.8.1 Release Bearer

This procedure is the same as that defined in the subclause "Release" in ITU-T Recommendation Q.1950 (see 3GPP TS 29.205 [7]) including the Modify command in the transaction.

### 14.2.8.2 Release Termination

This procedure is the same as that defined in the subclause "Release" in ITU-T Recommendation Q.1950 (see 3GPP TS 29.205 [7]) including a Subtract command in the transaction.

## 14.2.9 Bearer Released

This procedure is the same as that defined in the subclause "BNC Release" in ITU-T Recommendation Q.1950 (see 3GPP TS 29.205 [7]).

## 14.2.10 Bearer Established

This procedure is the same as that defined in the subclause "BNC Established" in ITU-T Recommendation Q.1950 (see 3GPP TS 29.205 [7]).

## 14.2.11 Send Tone

This procedure is the same as that defined in the subclause "Media Content Insertion" - "Insert Tone" in ITU-T Recommendation Q.1950 (see 3GPP TS 29.205 [7]) with the following additions.

Address Information	Control information	Bearer information
	If CAMEL Prepaid Warning Tone Signal = warning tone	

## 14.2.12 Play Announcement

This procedure is the same as that defined in the subclause "Media Content Insertion" - "Insert Announcement" in ITU-T Recommendation Q.1950 (see 3GPP TS 29.205 [7]).

## 14.2.13 Send DTMF

This procedure is the same as that defined in the subclause "Media Content Insertion" - "Insert Digit" in ITU-T Recommendation Q.1950 (see 3GPP TS 29.205 [7]). The MGW shall ensure the minimum duration timing and minimum interval timing is achieved in accordance with the DTMF timing defined in TS 23.014 [15]. Maximum duration shall also be controlled by the MGW if required by the network.

### 14.2.14 Detect DTMF

This procedure is the same as that defined in the subclause "Media Content Detection" - "Detect Digit" in ITU-T Recommendation Q.1950 (see 3GPP TS 29.205 [7]).

### 14.2.15 Report DTMF

This procedure is the same as that defined in the subclause "Detected Digit" in ITU-T Recommendation Q.1950 (see 3GPP TS 29.205 [7]).

### 14.2.16 Announcement Completed

This procedure is the same as that defined in the subclause "Signal Completion" in ITU-T Recommendation Q.1950 (see 3GPP TS 29.205 [7]).

### 14.2.17 Activate Voice Processing Function

When the procedure "Activate Voice Processing Function" (VPF) is required the following procedure is initiated:

The MGC sends an ADD.req, MOD.req or MOV.req command with the following information.

- 1 ADD.req/MOD.req/MOV.req (... , Activate Voice Processing Function) MGC to MGW

Address Information	Control information	Bearer information
	Transaction ID = z Context ID = c1 Termination ID = bearer1 VPF Type ActivateVPF = off / value	

When the MGW receives the command, it shall associate the relevant voice processing function resources with the specified termination.

When the processing of command (1) is complete, the MGW may initiate the "Voice Processing Function Ack" procedure.

- 2 ADD.resp/MOD.resp/MOV.resp (Voice Processing Function Ack) MGW to MGC

Address Information	Control information	Bearer information
	Transaction ID = z Context ID = c1 Termination ID = bearer1	

### 14.2.18 Reserve Circuit

This procedure is activated when the "Reserve Circuit" procedure is initiated.

An ADD.req, MOD.req or MOV.req command is sent with the following information.

- 1 ADD.req/MOD.req/MOV.req (Reserve\_Circuit) CSM to BIWF

Address Information	Control information	Bearer information
	Transaction ID = z Termination ID = bearer1  <u>Context Requested:</u> Context ID = ? <u>Context Provided:</u> Context ID = c1  If indication on Protocol Negotiation Result requested: NotificationRequested (Event ID = x, "Prot Negotiation Result")  If indication on Rate Change requested: NotificationRequested (Event ID = x, "RateChange")	Bearer Service Characteristics  If data call PLMN capabilities GSM channel coding = coding

Upon completion of processing command (1) an ADD.resp, MOD.resp or MOV.resp command (2) is sent.

2 ADD.resp/MOD.resp/MOV.resp

BIWF to CSM

Address Information	Control information	Bearer information
	Transaction ID = z Context ID = c1 TerminationID = bearer1	

### 14.2.19 Tunnel Information Up

This procedure is the same as that defined in the subclause "Tunnel" in ITU-T Recommendation Q.1950 (see 3GPP TS 29.205 [7]).

NOTE: This procedure is always initiated from the MGW.

### 14.2.20 Tunnel Information Down

This procedure is the same as that defined in the subclause "Tunnel" in ITU-T Recommendation Q.1950 (see 3GPP TS 29.205 [7]).

NOTE: This procedure is always initiated from the MGC.

### 14.2.21 Tone Completed

This procedure is the same as that defined in the subclause "Signal.Completion" in ITU-T Recommendation Q.1950 (see 3GPP TS 29.205 [7]).

### 14.2.22 Stop Announcement

This procedure is the same as that defined in the subclause "Insert Announcement" in ITU-T Recommendation Q.1950 (see 3GPP TS 29.205 [7]) with the following clarification. The signal descriptor shall not include any signal.

### 14.2.23 Stop Tone

This procedure is the same as that defined in the subclause "Insert Tone" in ITU-T Recommendation Q.1950 (see 3GPP TS 29.205 [7]) with the following clarification. The signal descriptor shall not include any signal.

### 14.2.24 Stop DTMF Detection

This procedure is the same as that defined in the subclause "Detect Digit" in ITU-T Recommendation Q.1950 (see 3GPP TS 29.205 [7]) with the following clarification. The eventDescriptor shall not include any event.

### 14.2.25 Stop DTMF

This procedure is the same as that defined in the subclause "Media Content Insertion" - "Insert Digit" in ITU-T Recommendation Q.1950 (see 3GPP TS 29.205 [7]). The signal descriptor shall not include any signal. The MGW shall ensure the minimum duration timing and minimum interval timing is achieved in accordance with the DTMF timing defined in TS 23.014 [15]. Maximum duration shall also be controlled by the MGW if required by the network.

### 14.2.26 Confirm Char

This procedure is the same as that defined in the subclause "Confirm Char" in ITU-T Recommendation Q.1950 (see 3GPP TS 29.205 [7]).

### 14.2.27 Modify Char

This procedure is the same as that defined in the subclause "Modify Char" in ITU-T Recommendation Q.1950 (see 3GPP TS 29.205 [7]).

### 14.2.28 Reserve Char

This procedure is the same as that defined in the subclause "Reserve Char" in ITU-T Recommendation Q.1950 (see 3GPP TS 29.205 [7]).

### 14.2.29 Bearer Modified

This procedure is the same as that defined in the subclause "BNC Modified" in ITU-T Recommendation Q.1950 (see 3GPP TS 29.205 [7]).

### 14.2.30 Bearer Modification Failed

This procedure is the same as that defined in the subclause "BNC Modification failure" in ITU-T Recommendation Q.1950 (see 3GPP TS 29.205 [7]).

### 14.2.31 TFO Activation

When the procedure "TFO activation" is required the following procedure is initiated:

The MGC sends a MOD.req command with the following information.

1 MOD.req (TFO activation) MGC to MGW

Address Information	Control information	Bearer information
	Transaction ID = z Context ID = c1 Termination ID = bearer1 Tfoenable = Off / value	

When the processing of command (1) is complete, the MGW initiates the following procedure.

2 MOD.resp (TFO activation) MGW to MGC

Address Information	Control information	Bearer information
	Transaction ID = z Context ID = c1 TerminationID=bearer1	

### 14.2.32 Optimal Codec and Distant List\_Notify

When the procedure "Optimal Codec and Distant List" is required the following procedure is initiated:

The MGC sends a MOD.req command with the following information.

- 1 MOD.req (Codec modify and distant list) MGC to MGW

Address Information	Control information	Bearer information
	Transaction ID = z Context ID = c1 Termination ID = bearer1 Property= codeclist  NotificationRequested (Event ID = x, "Codec modify") NotificationRequested (Event ID = x, "Distant List")	

When the processing of command (1) is complete, the MGW initiates the following procedure.

- 2 MOD.resp (Optimal codec and codec list) MGW to MGC

Address Information	Control information	Bearer information
	Transaction ID = z Context ID = c1 TerminationID= bearer1	

### 14.2.33 Codec Modify

When the procedure "Codec Modify" is required the following procedure is initiated:

The MGW sends a NOT.req command with the following information.

- 1 NOT.req (Codec modify) MGW to MGC

Address Information	Control information	Bearer information
	Transaction ID = z Context ID = c1 Termination ID = bearer1  Event_ID (Event ID = x, "Optimal codec")	

When the processing of command (1) is complete, the MGW initiates the following procedure.

- 2 NOT.resp (Codec modify) MGC to MGW



Address Information	Control information	Bearer information
	Transaction ID = z Context ID = c1 Termination ID = bearer1	

### 14.2.34 Distant Codec List

When the procedure "Distant Codec List" is required the following procedure is initiated:

The MGW sends a NOT.req command with the following information.

- 1 NOT.req (Distant codec list) MGW to MGC

Address Information	Control information	Bearer information
	Transaction ID = z Context ID = c1 Termination ID = bearer1  Event_ID (Event ID = x, "Distant list")	

When the processing of command (1) is complete, the MGW initiates the following procedure.

- 2 NOT.resp (Distant codec list) MGC to MGW

Address Information	Control information	Bearer information
	Transaction ID = z Context ID = c1 Termination ID = bearer1	

### 14.2.35 Command Rejected

When the procedure "Command Reject" is required the following procedure is initiated:

The MGW/MGC sends .resp to any command.req with the following information.

- 1 ANYcommand.resp (command reject) MGW/MGC to MGC/MGW

Address Information	Control information	Bearer information
	Transaction ID = z Context ID = c1 or no context  Reason=Error	

### 14.2.36 Modify Bearer Characteristics

This procedure is the same as that defined in the subclause "Modify Char" in ITU-T Recommendation Q.1950 (see 3GPP TS 29.205 [7]) with additions as shown below.

Address Information	Control information	Bearer information
	If framing protocol used: UP mode = mode UPversion =version Delivery of erroneous SDUs=value Interface=interface Initdirerection=initdirection Bitrate = bitrate  If indication on Protocol Negotiation Result requested: NotificationRequested (Event ID = x, "Prot Negotiation Result")  If indication on Rate Change requested: NotificationRequested (Event ID = x, "RateChange")	If data call:  PLMN bearer capbility = PLMN capability GSM channel coding=coding

If the "Modify Bearer Characteristics" procedure contains a codec that is not currently in use at the Termination when it receives this procedure, and if the framing protocol is used in support mode, the MGW shall be prepared to handle a framing protocol initialisation. If the "Modify Bearer Characteristics" contains no codec or the codec that is already in use at the Termination when it receives this procedure, the MGW does not need to be prepared to handle a framing protocol initialisation.

### 14.2.37 Protocol Negotiation Result

When the procedure "Protocol Negotiation Result" is required the following procedure is initiated:

The MGW sends a NOT.req command with the following information.

- 1 NOT.req (Protocol negotiation result) MGW to MGC

Address Information	Control information	Bearer information
	Transaction ID = z Context ID = c1 Termination ID = bearer1  Event_ID (Event ID = x, "Result", "Cause")	

When the processing of command (1) is complete, the MGW initiates the following procedure.

- 2 NOT.resp (Protocol negotiation result) MGC to MGW

Address Information	Control information	Bearer information
	Transaction ID = z Context ID = c1 Termination ID = bearer1	

### 14.2.38 Rate Change

When the procedure "Rate Change" is required the following procedure is initiated:

The MGW sends a NOT.req command with the following information.

1 NOT.req (Rate change)

MGW to MGC

Address Information	Control information	Bearer information
	Transaction ID = z Context ID = c1 Termination ID = bearer1  Event_ID (Event ID = x, "Rate")	

When the processing of command (1) is complete, the MGW initiates the following procedure.

2 NOT.resp (Rate change)

MGC to MGW

Address Information	Control information	Bearer information
	Transaction ID = z Context ID = c1 Termination ID = bearer1	

### 14.2.39 Bearer Modification Support

When the procedure "Bearer Modification Support" is required, the following procedure is initiated:

The MGW sends a NOT.req command with the following information to indicate that the bearer can be modified.

1 NOT.req (Bearer Modification Support)

MGW to MGC

Address Information	Control information	Bearer information
	Transaction ID = z Context ID = c1 Termination ID = bearer1  Event_ID (Event ID = x, "Bearer modification possible")	

When the processing of command (1) is complete, the MGW initiates the following procedure.

2 NOT.resp (Bearer Modification Support)

MGC to MGW

Address Information	Control information	Bearer information
	Transaction ID = z Context ID = c1 Termination ID = bearer1	

### 14.2.40 Reserve Bearer Characteristics

This procedure is the same as that defined in the subclause "Reserve Char" in ITU-T Recommendation Q.1950 (see 3GPP TS 29.205 [7]) with additions as shown below.

Address Information	Control information	Bearer information
	If framing protocol used:  UP mode = mode UPversion =version Delivery of erroneous SDUs=value Interface=interface Initdirection=initdirection	

If the "Reserve Bearer Characteristics" procedure contains a codec that is not currently in use at the Termination when it receives this procedure, and if the framing protocol is used in support mode, the MGW shall be prepared to handle a framing protocol initialisation. If the "Reserve Bearer Characteristics" contains no codec or the codec that is already in use at the Termination when it receives this procedure, the MGW does not need to be prepared to handle a framing protocol initialisation.

#### 14.2.41 Confirm Bearer Characteristics

This procedure is the same as that defined in the subclause "Confirm Char" in ITU-T Recommendation Q.1950 (see 3GPP TS 29.205 [7]) with additions as shown below.

Address Information	Control information	Bearer information
	If framing protocol used:  UP mode = mode UPversion =version Delivery of erroneous SDUs=value Interface=interface Initdirection=initdirection	

If the "Confirm Bearer Characteristics" procedure contains a codec that is not currently in use at the Termination when it receives this procedure, and if the framing protocol is used in support mode, the MGW shall be prepared to handle a framing protocol initialisation. If the "Confirm Bearer Characteristics" contains no codec or the codec that is already in use at the Termination when it receives this procedure, the MGW does not need to be prepared to handle a framing protocol initialisation.

---

## 15 UMTS packages

### 15.1 Mandatory UMTS packages

The following packages are required for the UMTS Bearer Independent Circuit-Switched Core Network:

- 3GUP (User Plane) package (see subclause 15.1.1);
- Circuit Switched Data package (see subclause 15.1.2);
- TFO package (see subclause 15.1.3).

## 15.1.1 3GUP package.

PackageID: threegup (0x002f)

Version: 1

Extends: None

This package identifies that the User Plane package is used for the termination. It also contains some parameters for the User Plane functions in the MGW.

The UP Protocol operates independently of the stream mode property, i.e. type 14 UP PDUs (which are used for inband UP signalling) can be transported between UP peers, irrespective of the stream mode direction. However, other types of UP PDUs shall be handled according to the stream mode property.

### 15.1.1.1 Properties

UP Mode of operation:

PropertyID: mode (0x0001)

Description: Defines the mode of operation of the User Plane functions , for further definitions see 3GPP TS 25.415 [4] and 29.415 [8].

Type: Enumeration

Possible Values:

"Trans" (0x0001) Transparent mode

"Supp" (0x0002) Support mode for predefined SDU sizes

Default: "Trans" (0x0001) Transparent mode

Defined in: Local Control descriptor

Characteristics: Read/Write

UP versions:

PropertyID: upversions (0x0002)

Description: Defines the required versions of the UP mode of operation.

Type: Sub-list of enumeration

Possible Values:

"1" (0x01) Version 1

"2" (0x02) Version 2

"3" (0x03) Version 3

"4" (0x04) Version 4

"5" (0x05) Version 5

"6" (0x06) Version 6

"7" (0x07) Version 7

"8" (0x08) Version 8

"9" (0x09) Version 9

"10" (0x0A) Version 10

"11" (0x0B) Version 11

"12" (0x0C) Version 12

"13" (0x0D) Version 13

"14" (0x0E) Version 14

"15" (0x0F) Version 15

"16" (0x10) Version 16

Default: "1" (0x01) Version 1

Defined in: Local Control descriptor

Characteristics: Read/Write

Delivery of erroneous SDUs:

PropertyID: delerrsdu (0x0003)

Description:

Indicates how erroneous SDUs should be handled. If it is set to YES then the UP entity implements error checking and sets Frame Quality Classification (FQC) bits accordingly; bad frames are delivered to the UP layer. If it is set to NO then the UP entity performs error checking and if a bad frame is detected then it is discarded. These settings are required only when the payload is to be examined by upper layer services; an MGW may ignore the settings of this parameter if it passes frames transparently through the UP entities. If it is set to NA then no checking is performed.

Type: Enumeration

Possible Values:

"Yes" (0x0001) Yes

"No" (0x0002) No

"NA" (0x0003) Not Applicable

Default: "NA" (0x0003) Not Applicable

Defined in: Local Control descriptor

Characteristics: Read/Write

Interface:

PropertyID: interface (0x0004)

Description: Indicates the type of interface on which the termination is used.

Type: Enumeration

Possible Values:

"RAN" (0x0001) Iu interface

"CN" (0x0002) Nb interface

Defined in: Local Control descriptor

Characteristics: Read/Write

Initialisation Direction

PropertyID: initdir (0x0005)

**Description:**

Indicates whether or not the termination in the MGW should expect initialisation information, or initiate UP initialisation itself.

For a termination with property "interface = CN":

- If Initialisation Direction is set to Incoming then the MGW shall expect to receive an initialisation either at this termination or from an other Nb or Iu termination in the same context.
- If Initialisation Direction is set to outgoing, then the MGW shall generate an initialisation procedure at this termination independently of the other termination in the same context.

For a termination with property "interface = Iu":

- If Initialisation Direction is set to "incoming", then the initialisation received at this termination is from the originating RAN and can be forwarded internally to other terminations for subsequent UP initialisations.
- If Initialisation Direction is set to "outgoing", then initialisations received are from the terminating RAN and cannot be forwarded internally. RFCI value correction can be performed at this termination, and initialisations can be sent out to the RAN.

Examples for the usage of this property are given in Annex B.

Type: Enumeration

Possible Values:

"In" (0x0001) Incoming

"Out" (0x0002) Outgoing

Defined in: Local Control descriptor

Characteristics: Read/Write

### 15.1.1.2 Events

None

### 15.1.1.3 Signals

None

### 15.1.1.4 Statistics

None

### 15.1.1.5 Procedures

The MGC uses this package to indicate to the MGW that the Iu (or Nb) User Plane is used between the RNC (or distant MGW) and the MGW. The package is sent in the Establish bearer, Modify Bearer Characteristics and Prepare bearer procedures. For more information on the User Plane and for a description of 'UP mode of operation', 'UP versions' and 'Delivery of erroneous SDUs' see 3GPP TS 25.415 [4].

The following procedures are valid for UP in Support Mode:

- TheMGW shall be able to initiate and respond to the UP control procedures (PDU type 14 frames) independently of the Stream Mode during the call establishment phase, i.e. when not in TrFO.
- Otherwise, during TrFO the MGW shall be able to forward UP control procedures (PDU type 14 frames) received at one termination to the other termination.

- The UP Initialisation procedure is always acknowledged between MGW peers. If an MGW receives a request for a notification for the bearer establishment then the MGW shall not send the notification until after it has sent the acknowledgement for the UP initialisation.
- The MGW shall always store RFCI parameters against the MGW termination which received the UP initialisation.
- If an MGW has the UP termination property Initialisation Direction = Incoming then it expects to receive an Initialisation (either internally or externally).
- If an MGW has UP termination property Initialisation Direction = Outgoing and interface CN, then it generates a network originated Initialisation PDU.
- If an MGW has UP termination property Initialisation Direction = Outgoing and interface RAN, then it expects to receive an Initialisation externally. It shall not pass the initialisation parameters internally. It may initiate RFCI Value Correction out from this termination.
- If an MGW has two terminations in the same context defined as supporting the UP package and with Initialisation Direction incoming, then when it receives an Initialisation procedure from one side (provided the bearer connection from the other termination to its peer MGW is established) it shall start the UP initialisation procedure towards the peer MGW. The MGW shall perform this procedure independently of the through-connection of the terminations in the context. The MGW shall relay control information from the first initialisation to the UP peer for use at the subsequent initialisation. Also, subsequent control procedures received on one UP shall be relayed to the other UP entity when the two UP entities are connected within the MGW. This behaviour is described in more detail in Annex A.
- If an MGW has one termination with properties "interface = Iu" and "initialisation direction = outgoing" and another termination with property "initialisation direction = Incoming" in the same context, then the MGW shall not forward the UP initialisation from the Incoming termination until it has received a UP initialisation at the "Iu"/"outgoing" side. If the RFCI values stored at the "incoming" termination do not match the RFCI values stored at the "outgoing" Iu side then "RFCI Value Correction" may be performed to the "outgoing" Iu side: The MGW starts UP initialisation with the RFCI values 'relayed' from the "Incoming" side. No "RFCI Value Correction" is permitted at a "incoming" Iu termination or at any Nb termination.
- As an implementation option, "RFCI Value Correction" may be delayed if terminations are not through-connected; it will be triggered by connection modification. Otherwise it shall be performed immediately
- If "RFCI Value Correction" is not performed the MGW shall map the indexes for frames from one side to the RFCI indexes for frames from the other side. This behaviour is described in more detail in Annex A.
- If an MGW has two Iu terminations connected to the same context then the "RFCI Value Correction" is performed by the Outgoing termination.
- If an MGW has two terminations which support the UP package connected to the same context and both RFCI sets match then the MGW may pass frames transparently through the UP entities; no monitoring of the frames is performed, provided that the terminations are through-connected. This behaviour is described further in Annex A.
- If the MGW is passing frames transparently, no UP monitoring is performed. When the MGW receives an H.248 procedure request which requires interpretation or interaction with the UP, then it shall resume its UP protocol responsibilities, i.e. perform monitoring or termination of the UP protocol.
- If an MGW sends an FP UP initialisation message from a termination, the MGW shall only offer versions of the FP UP, which are given in the property "UP versions" of this termination and which are supported by the MGW for this termination.
- If an MGW receives an FP UP initialisation message at a termination, the MGW shall only positively acknowledge this initialisation message, if versions of the FP UP are offered, which are given in the property "UP versions" and which are supported at the MGW for this termination. In the positive FP UP initialisation acknowledge message, the MGW shall select one of these versions. If none of these versions are offered in the FP UP initialisation message, the MGW shall send a negative FP UP acknowledge message and it shall not forward the initialisation to a possible second FP UP termination in the same context.
- If PCM is used on the Nb then FP UP initialisation shall be performed by the termination with property "Outgoing". If the termination property is "Incoming" then it shall receive the RFCI's from its IuFP peer (or



from internal MGW termination with IuFP and same codec). If IuFP is defined on another termination in the MGW but the codec is different, i.e. not TrFO then the relaying of RFCI's shall not be performed. These IuFP peer connection shall be seen as completely separate.

## 15.1.2 Circuit Switched Data package

PackageID: threegcsd (0x0030)

Version: 1

Extends: None

This package contains the information needed to be able to support GSM and UMTS Circuit Switched Data from the media gateway.

### 15.1.2.1 Properties

PLMN BC

PropertyID: plmnbc (0x0001)

Description: The PLMN Bearer Capability.

Type: Octet string

Possible values:

Specified in the subclause "Bearer capability" in 3GPP TS 24.008 [3].

Defined in: Local Control Descriptor

Characteristics: Read/Write

GSM channel coding

PropertyID: gsmchancod (0x0002)

Description: Channel information needed for GSM.

Type: Octet string

Possible values:

The second octet of Chosen Channel as specified in the subclause "Chosen Channel" in 3GPP TS 48.008 [9].

Defined in: Local Control Descriptor

Characteristics: Read/Write

### 15.1.2.2 Events

Protocol Negotiation Result

EventID: protres (0x0001)

Description: This event is used to report the result of the protocol negotiation.

EventsDescriptor Parameters: None

ObservedEventsDescriptor Parameters:

Negotiation Result

ParameterId: result (0x0001)

Description: reports whether the protocol negotiation has been successful.

Type: Enumeration

Possible Values:

"Success" (0x0001): the protocol negotiation on the termination has been successful,

"Failure" (0x0000): the protocol negotiation on the termination has failed.

Possible Failure Cause

ParameterId: cause (0x0002)

Description: indicates the possible failure cause

Type: Enumeration

Possible Values:

"Unsp" (0x0001): the protocol negotiation has failed for an unspecified reason,

"V8V34" (0x0002): the V.8 or the V.34 protocol negotiation has failed (modem termination only).

Rate Change

EventID: ratechg (0x0002)

Description: This event is used to report a rate change.

EventsDescriptor Parameters: None

ObservedEventsDescriptor Parameters:

New Rate

ParameterId: rate (0x0001)

Description: reports the new rate for the termination.

Type: Integer.

Possible Values:

transmission rate in bits per second, rounded to the nearest integer value. The value must be a valid bitrate (e.g. 33 600, 28 800).

### 15.1.2.3 Signals

Activate Protocol

SignalID: actprot (0x0001)

Description: Activate the higher layer protocol.

Signal type: Brief

Duration: N/A

Additional parameter:

Local Peer Role

ParameterID: localpeer (0x0001)

Type: Enumeration

Possible values:

"Orig" (0x0000): originating

"Term" (0x0001): terminating

Description:

This parameter is optional, but is required for modem and fax calls. It is used to inform the modem whether it should act as originating or terminating peer.

#### 15.1.2.4 Statistics

None

#### 15.1.2.5 Procedures

This package is used to set up data calls within the CS domain. For more information on the IWF, refer to 3GPP TS 29.007 [6].

When the Media Gateway Controller initiates the "Establish Bearer" procedure, the "Prepare Bearer" procedure, the "Modify Bearer" procedure or the "Reserve Circuit" procedure, it shall provide the PLMN BC ("plmnc" property above) for the termination on the mobile side and the ISDN BC (standard H.248 properties, chapter "Bearer Capabilities") for the termination on the fixed side. For a mobile-to-mobile call, it shall provide the PLMN BC on both terminations.

The presence of the PLMN BC property may trigger the use of the IWF.

Once the bearer has been established, after B-answer, the "Activate Interworking Function" procedure is used to activate the IWF. The Activate Protocol signal ("actprot") will start the negotiation of the layer 2 protocols on both sides. If a modem or fax service is requested, the signal shall contain the Local Peer Role parameter ("localpeer"), to tell the modem whether it should act as originating or terminating peer.

NOTE: The Activate Protocol signal is needed only after B-answer as described above, to activate the protocol timers at the correct time. This is the only time when this signal is needed (specifically, the signal is not used after a handover sequence or for lawful interception).

The IWF Protocol Indication notifications are used by the MGW to inform the MSC server about IWF protocol events. The MSC has to request the detection of the events "Protocol Negotiation Result" and "Rate Change" in the "Activate IWF" procedure, the "Establish Bearer" procedure, the "Prepare Bearer" procedure, the "Modify Bearer" procedure or the "Reserve Circuit" procedure.

For handover to GSM, or change of channel characteristics within the GSM network, the property GSM Channel Coding ("gsmchancod"), which contains the information about the channel type and the number of channels, shall be transmitted to the termination on the mobile side in the "Establish Bearer", the "Prepare Bearer" and the "Reserve Circuit" procedures together with the PLMN BC. The presence of the GSM Channel Coding property also indicates that the termination is using a GSM access network.

### 15.1.3 TFO package

**The addition of text encoding for the TFO codec list is for further study.**

PackageID: threegtfo (0x0031)

Version: 1

Extends: None

This package defines events and properties for Tandem Free Operation (TFO) control. TFO uses inband signalling and procedures for Transcoders to enable compressed speech to be maintained between a tandem pair of transcoders. This package allows an MGW which has inserted a transcoder to support TFO.

#### 15.1.3.1 Properties

TFO Activity Control

PropertyID: tfoenable (0x0001)

Description: Defines if TFO is enabled or not.

Type: Enumeration

Possible Values:

"On" (0x0001): TFO is enabled, TFO protocol is supported

"Off" (0x0002): TFO is not enabled, TFO protocol is not initiated or terminated

Defined in: Local Control descriptor

Characteristics: Read/Write

#### TFO Codec List

PropertyID: codeclist (0x0002)

Description: List of codecs for use in TFO protocol, the active codec is always the first entry in the list.

Type: Octet string

Possible Values:

List of codec types; each entry:

As defined in Q.765.5, for single codec information (Figure 14/Q.765.5), where the Codec Information is defined either in Q.765.5 or in another specification for the given Organisation Identifier.

Defined in: Local Control descriptor

Characteristics: Read/Write

### 15.1.3.2 Events

#### Optimal Codec Event

EventID: codec\_modify (0x0010)

Description:

The event is used to notify the MGC that TFO negotiation has resulted in an optimal codec type being proposed.

EventsDescriptor Parameters: None

ObservedEventsDescriptor Parameters:

Optimal Codec Type

ParameterID: optimalcodec (0x0011)

Description: indicates which is the proposed codec type for TFO

Type: Octet string

Possible Values:

Codec Type:

As defined in Q.765.5, for single codec information (Figure 14/Q.765.5), where the Codec Information is defined either in Q.765.5 or in another specification for the given Organisation Identifier.

#### Codec List Event

EventID: distant\_codec\_list (0x0012)

Description: The event is used to notify the MGC of the distant TFO partner's supported codec list..

EventsDescriptor Parameters: None

ObservedEventsDescriptor Parameters:

Distant Codec List

ParameterID: distlist(0x0013)

Description: indicates the codec list for TFO

Type: Octet string

Possible Values:

List of codecs of type Codec Type:

As defined in Q.765.5, for single codec information (Figure 14/Q.765.5), where the Codec Information is defined either in Q.765.5 or in another specification for the given Organisation Identifier.

The first Codec Type in the list is the one proposed for use (Optimal Codec Type).

### 15.1.3.3 Signals

None

### 15.1.3.4 Statistics

None

### 15.1.3.5 Procedures

For the procedures for TFO see 3GPP TS 28.062 [5].

The use of the properties in this package is applicable only when the MGW Termination to which the package properties are applied has the media stream property for Codec Type set to ITU-T G.711 (see Annex C of ITU-T Recommendation H.248). Furthermore, the package properties are applicable only if the Codec Type property of the media stream at the opposing MGW Termination is not set to ITU G.711.

## 15.1.4 3G Expanded Call Progress Tones Generator Package

PackageID: threegxcg(0x0032)

Version: 1

Extends: xcg version1

This package extends "Expanded Call Progress Tones Generator Package", as defined in ITU-T Recommendation Q.1950 (see 3GPP TS 29.205 [7]). The package adds a new toneId for CAMEL prepaid warning tone.

### 15.1.4.1 Properties

None

### 15.1.4.2 Events

None

### 15.1.4.3 Signals

CAMEL Prepaid Warning Tone

SignalID: cpwt (0x004f)

Description:

Generate CAMEL prepaid warning tone to inform the party that the Max Call Period Duration is about to expire. CAMEL prepaid warning tone is defined in TS 23.078. The physical characteristic of CAMEL prepaid warning tone is available in the gateway.

Signal type: Brief

Duration: Provisioned, Not Auditable

Additional parameters:

Tone Direction

ParameterID: td (0x0010)

Type: Enumeration

Values:

"Ext" (0x01): external,

"Int" (0x02): internal,

"Both" (0x03): Both

Default: "Ext"

#### 15.1.4.4 Statistics

None

#### 15.1.4.5 Procedures

None

### 15.1.5 Modification Of Link Characteristics Bearer Capability

PackageName: Modification of Link Characteristics Bearer Capability

PackageID: threegmlc(0x0046)

Description: This package contains an event that when requested by the MGC will cause the MG to notify the MGC that modification of the link characteristics is allowed. This notification is typically generated when the bearer has been established.

Version: 1

Extends: None

#### 15.1.5.1 Properties

None

#### 15.1.5.2 Events

Bearer Modification Support Event

EventID: mod\_link\_supp (0x0001)

Description:

The event is used to notify the MGC that modification of the link characteristics of the current bearer connection is permitted.

EventsDescriptor Parameters: None

ObservedEventsDescriptor Parameters: None

### 15.1.5.3 Signals

None

### 15.1.5.4 Statistics

None

### 15.1.5.5 Procedures

If the MGC is interested in determining whether or not the bearer associated with a termination supports modification of its link characteristics it shall send a request (Add/Modify/Move) with the Bearer Modification Support Event. When the bearer is established the MG will indicate in a Notify request to the MGC if modification of link characteristics is supported. A notify will NOT be generated if modification is NOT supported on the bearer.

## 15.1.6 Void

## 15.1.7 Enhanced Circuit Switched Data package

PackageID: threegcsden (0x00??) [Editor's note: This needs to be registered with IANA]

Version: 1

Extends: threegcsd (0x030) Version 1

This package extends "Circuit Switched Data Package", as defined in clause 15.1.2. This package adds a new property to define the user bitrate at a Nb/Iu termination.

### 15.1.7.1 Properties

Bitrate

PropertyID: bitrate (0x0003)

Description: user bitrate

Type: Integer.

Possible Values:

transmission rate in bits per second, rounded to the nearest integer value. The value must be a valid bitrate (e.g. 33 600, 28 800).

Defined in: Local Control Descriptor

Characteristics: Read/Write

### 15.1.7.2 Events

None

### 15.1.7.3 Signals

None.

#### 15.1.7.4 Statistics

None

#### 15.1.7.5 Procedures

This package is used in addition to the 3GCSD package for CS data calls. It is used for indicating the user data rates for Inter-MSC SRNS Relocation and handover cases. If the Bitrate is not 64kb/s at one termination in the MGW but its opposing termination has properties that define its bitrate to be 64kb/s (e.g. TMR=UDI) then A-TRAU' protocol shall be applied by the MGW. For further details see 3G TS 29.007 [6].

## 15.2 Optional UMTS packages



# Annex A (informative): The Framing protocol Interworking Function (FPIF)

## A.1 Introduction

SDUs transmitted over an Iu or Nb interface and received at a MGW whose outgoing UP is also Iu or Nb shall be relayed to the outgoing UP MGW termination. If no interworking function (other than the FPIF) or transcoder device is inserted by the MGW, and if UP terminations are present, then PDUs and control procedures are passed between MGW terminations by the FPIF. The FPIF is the functional entity responsible for aligning or mapping control procedures (including RFCIs, frame numbers etc) on the separate UP interfaces according to the package procedures described in the main text. The FPIF determines if the two UP configurations are identical and thus the UP PDUs may be passed transparently. If the FPIF determines that the two UP configurations are not identical it applies the required mapping. The relaying of PDUs transparently can also be considered as FPIF bypass.

NOTE: the implementation in the MGW can perform a more efficient processing of the PDUs in this case. The MGW switching and bypassing of the protocol functions during TrFO is left to the manufacturer's implementation.

UP initialisations are not handled by the FPIF, only receipt of the Subflow combinations and the RFCI allocations are received by the FPIF for each UP.

The RFCIs are relayed by the FPIF as described in main text for the UP package procedures.

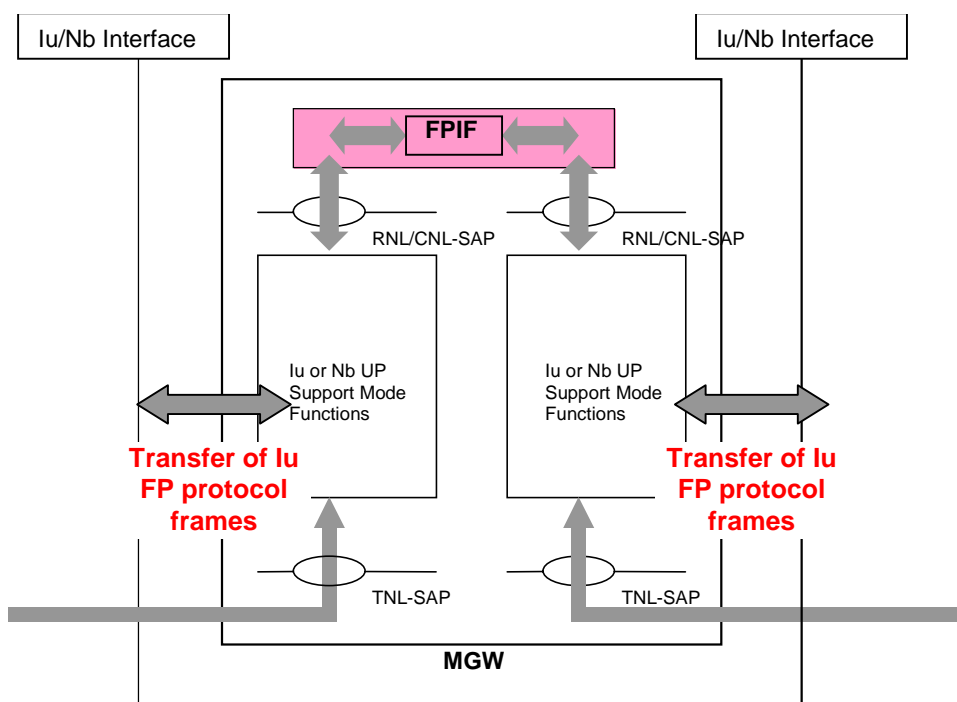

Figure A.1: The Framing Protocol Interworking Function

## A.2 FPIF procedures with respect to Iu framing protocol

This section handles relay of user data indicated to the FPIF in a Nb- or Iu-UP-data-indication message and transmitted between peer UP layer entities in PDU types 0 and 1. The FPIF passes this information to the UP layer on the sending side in a Nb- or Iu-UP-data-request message.

## A.2.1 Payload

Received SDUs shall be forwarded unmodified to the next MGW. Note that if "delivery of erroneous SDUs" is set to 'no', faulty SDUs are already discarded by the Iu or Nb support mode functions and, hence, not delivered to the FPIF.

## A.2.2 RFCIs

If the RFCI values on the outgoing UP interface match those initialised on the incoming UP interface then the RFCI indicated by the lower layer (i.e., Iu or Nb) on the receiving side shall be forwarded unmodified to lower layer on the sending side.

If the RFCI sets on the outgoing UP interface do not match those initialised on the incoming UP interface then the FPIF performs mapping between the RFCIs on each UP for the same initialised Subflow Combination.

The FPIF is the entity that may perform the RFCI value correction procedure as described in the main text, after this procedure then relaying of the received RFCI shall be performed.

## A.2.3 FQC

The FQC indicated by the lower layer (i.e., Iu or Nb) on the receiving side shall be forwarded unmodified to lower layer on the sending side.

## A.2.4 Frame number

The frame number indicated by the lower layer (i.e., Iu or Nb) on the receiving side shall be forwarded unmodified to lower layer on the sending side.

A discontinuity in framing protocol support mode frame numbers is allowed at the end of the TrFO break.

---

# A.3 Relay of status information

This section handles relay of status information indicated to the FPIF in a Nb- or Iu-UP-status-indication message and transmitted between peer UP layer entities in PDU type 14. The FPIF in general passes this information to the UP layer on the sending side.

## A.3.1 Void

## A.3.2 Rate Control Frames

The FPIF shall pass rate control request and rate control acknowledgement frames transparently between incoming UP interface and outgoing UP interface.

Before a MGW reverts from TrFO break operation (for example during handover or relocation where the rate control procedures may have been operating independently between each UP interface) the FPIF may perform rate control procedures to each UP peer. It shall then use the Maximum rate and Current rate settings from the opposite UP configurations. This is performed to align the UP's on each side of the MGW to enable relaying of all subsequent PDUs as described above.

Optionally, the UP layer protocol entity on the sending side may substitute the frame number received in a status request by another number, but shall then substitute the initial number back in the status indication containing the acknowledgement. Figure 8 shows an example of the relay of the rate control procedure.

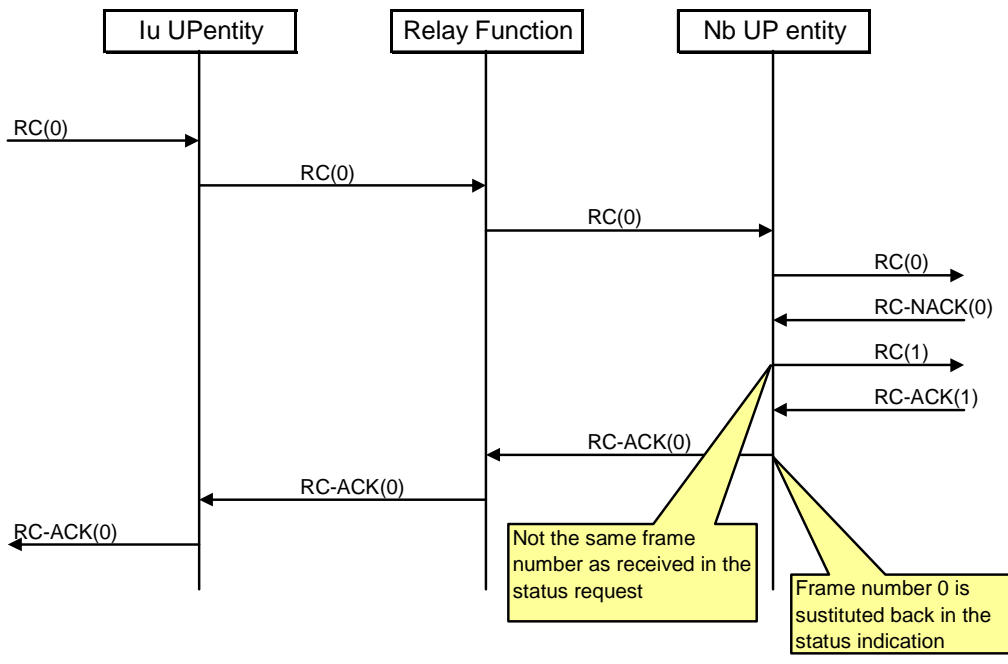
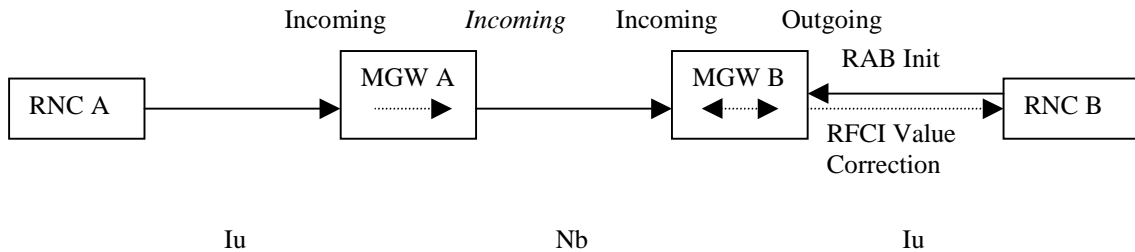

Figure A.2: Relay of a control procedure

### A.3.2 Time Alignment

Time alignment frames shall be relayed unmodified.

# Annex B (informative): Examples for Usage of the 3GPP Package “Initialisation Direction” Property



**Figure B.1: Mobile to Mobile Call (A to B)**

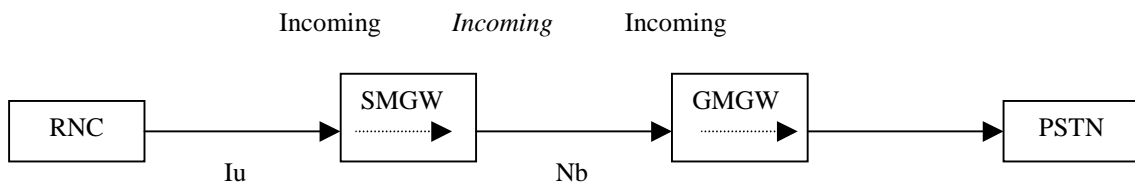

**Figure B.2: Mobile Originating Call**

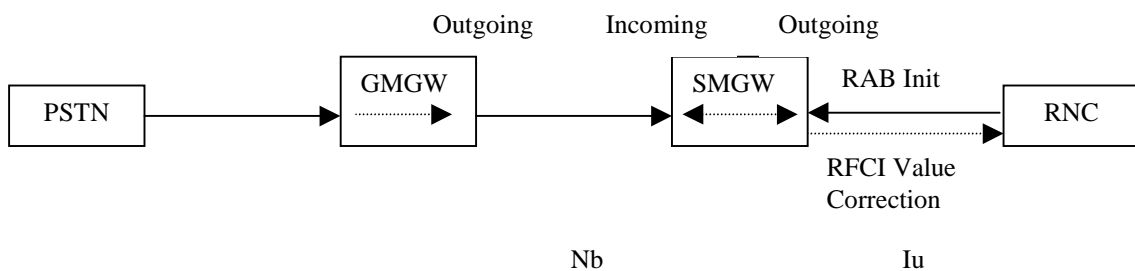

**Figure B.3: Mobile Terminating Call**

## Annex C (informative): Change history

Change history							
Date	TSG #	TSG Doc.	CR	Rev	Subject/Comment	Old	New
Sep 2000					Initial draft created after N4#4 based on N4-000620	0.0.1	0.1.0
October 2000					Updated after N4 R2000 Ad Hoc Stockholm based on N4-00823 and N4-000842	0.1.0	0.2.0
Nov 2000					Reference for MTP 3B corrected; RFC reference for SCTP added	0.2.0	0.3.0
Nov 2000					Updated according to N4-000996, N4-000998, N4-000999, N4-001000, N4-001021, N4-001028 & N4-001097 as agreed in CN4 #5	0.3.0	1.0.0
Nov 2000	CN#10				To TSG-CN Plenary #10 for information	1.0.0	1.1.0
Jan 2001					Updated according to NJ-010069, NJ-010030, NJ-010098, NJ-010094, NJ-010033, NJ-010097, NJ-010095, NJ-010112 as agreed in the Joint CN3/CN4 Meeting held during the CN4#6	1.1.0	1.1.1
Jan 2001					References ordered by specification/recommendation number; references to 3GPP specifications include full titles as shown on the title page; literal reference numbers and references to subclauses replaced with fields; all table cells outlined with 0.5pt lines; appropriate 3GPP paragraph styles applied.	1.1.1	1.2.0
Feb 2001					Updated according to N4-010245, N4-010248, N4-010249, N4-010303, N4-010304, N4-010305, agreed in CN4 Release 4 ad hoc, Madrid. References to Q.1902.x replaced by references to 29.205; 3GPP styles applied consistently; form for ITU-T recommendations in text is now "ITU-T Recommendation A.NNNN".	1.2.0	1.3.0
Mar 2001					Updated according to N4-010384, N4-010401 (part) & N4-010472, agreed in CN4 in Sophia Antipolis. References to Q.1950, Q.1970 and Q.1990 replaced by reference to 29.205. Reference to SIP-T deleted. Editor's note in 15.1.2.3 deleted. Editorial clean-up.	1.3.0	2.0.0
Mar 2001					Sent to TSG CN#11 for approval	2.0.0	2.1.0
Mar 2001	CN#11				References updated after comments in TSG CN #11 Approved in CN#11	2.1.0	4.0.0
Jun 2001	CN#12	NP-010284	1	1	Text encoding of codec information on Mc interface	4.0.0	4.1.0
Jun 2001	CN#12	NP-010284	4	2	ATM-IP signalling transport Interworking	4.0.0	4.1.0
Jun 2001	CN#12	NP-010284	5	1	Alignment of Procedure names to TS 23.205 and Q.1950	4.0.0	4.1.0
Jun 2001	CN#12	NP-010284	6	3	Clarifications in 3GUP package	4.0.0	4.1.0
Jun 2001	CN#12	NP-010284	7	1	Clarification of Use of UP version property in 3GUP package	4.0.0	4.1.0
Jun 2001	CN#12	NP-010284	8	1	Updates to UP Relay Function, Appendix A	4.0.0	4.1.0
Sep 2001	CN#13				Editorial clean up	4.1.0	4.2.0
Sep 2001	CN#13	NP-010452	009		Addition of package numbers allocated by IANA	4.1.0	4.2.0
Sep 2001	CN#13	NP-010452	010	1	Mc signalling transport in IP environment	4.1.0	4.2.0
Dec 2001	CN#14	NP-010619	011	1	Inclusion of H.248 Annex L, "Error Codes and Service Change Reason Description"	4.2.0	4.3.0
Dec 2001	CN#14	NP-010619	012		Removal of the Reuse Idle Package	4.2.0	4.3.0
Dec 2001	CN#14	NP-010619	014		Correction of Release Procedures	4.2.0	4.3.0
Dec 2001	CN#14	NP-010619	015		Clarification Of Use Of 3GUP package For PCM	4.2.0	4.3.0
Dec 2001	CN#14	NP-010619	016		Corrections to ABNF coding of PackageIDs	4.2.0	4.3.0
Dec 2001	CN#14	NP-010619	017		Correction of BICC packages	4.2.0	4.3.0
Dec 2001	CN#14	NP-010619	020	1	Correction of 3GUP package sub-list type	4.2.0	4.3.0
Mar 2002	CN#15	NP-020029	024	2	Naming convention for TDM resources	4.3.0	4.4.0
Mar 2002	CN#15	NP-020029	026	2	Correction of Bearer Modification Handling	4.3.0	4.4.0
Jun 2002	CN#16	NP-020249	035		Correction Section 14.1.6 of 3GPP TS 29.332	4.4.0	4.5.0
Sep 2002	CN#17	NP-020463	043	1	Missing Properties For Circuit Switched Data Calls	4.5.0	4.6.0
Dec 2002	CN#18	NP-020579	040	2	Termination ID Correction	4.6.0	4.7.0
Dec 2002	CN#18	NP-020578	045	2	Updates to support Codec Modification	4.6.0	4.7.0
Jun 2003	CN#20	NP-030211	058		Clarification of handling of DTMF in split architecture – DTMF timing	4.7.0	4.8.0

---

## History

<b>Document history</b>		
V4.0.0	March 2001	Publication
V4.1.0	June 2001	Publication
V4.2.0	September 2001	Publication
V4.3.0	December 2001	Publication
V4.4.0	March 2002	Publication
V4.5.0	June 2002	Publication
V4.6.0	September 2002	Publication
V4.7.0	December 2002	Publication
V4.8.0	June 2003	Publication