

# ETSI TS 129 414 V13.2.0 (2017-01)



## **Universal Mobile Telecommunications System (UMTS); Core network Nb data transport and transport signalling (3GPP TS 29.414 version 13.2.0 Release 13)**



---

**Reference**RTS/TSGC-0329414vd20

---

**Keywords**UMTS

---

**ETSI**

---

650 Route des Lucioles  
F-06921 Sophia Antipolis Cedex - FRANCE

---

Tel.: +33 4 92 94 42 00 Fax: +33 4 93 65 47 16

Siret N° 348 623 562 00017 - NAF 742 C  
Association à but non lucratif enregistrée à la  
Sous-Préfecture de Grasse (06) N° 7803/88

---

**Important notice**

---

The present document can be downloaded from:  
<http://www.etsi.org/standards-search>

The present document may be made available in electronic versions and/or in print. The content of any electronic and/or print versions of the present document shall not be modified without the prior written authorization of ETSI. In case of any existing or perceived difference in contents between such versions and/or in print, the only prevailing document is the print of the Portable Document Format (PDF) version kept on a specific network drive within ETSI Secretariat.

Users of the present document should be aware that the document may be subject to revision or change of status. Information on the current status of this and other ETSI documents is available at  
<https://portal.etsi.org/TB/ETSIDeliverableStatus.aspx>

If you find errors in the present document, please send your comment to one of the following services:  
<https://portal.etsi.org/People/CommiteeSupportStaff.aspx>

---

**Copyright Notification**

---

No part may be reproduced or utilized in any form or by any means, electronic or mechanical, including photocopying and microfilm except as authorized by written permission of ETSI.

The content of the PDF version shall not be modified without the written authorization of ETSI.  
The copyright and the foregoing restriction extend to reproduction in all media.

© European Telecommunications Standards Institute 2017.  
All rights reserved.

**DECT™**, **PLUGTESTS™**, **UMTS™** and the ETSI logo are Trade Marks of ETSI registered for the benefit of its Members.  
**3GPP™** and **LTE™** are Trade Marks of ETSI registered for the benefit of its Members and of the 3GPP Organizational Partners.  
**GSM®** and the GSM logo are Trade Marks registered and owned by the GSM Association.

---

## Intellectual Property Rights

IPRs essential or potentially essential to the present document may have been declared to ETSI. The information pertaining to these essential IPRs, if any, is publicly available for **ETSI members and non-members**, and can be found in ETSI SR 000 314: *"Intellectual Property Rights (IPRs); Essential, or potentially Essential, IPRs notified to ETSI in respect of ETSI standards"*, which is available from the ETSI Secretariat. Latest updates are available on the ETSI Web server (<https://ipr.etsi.org>).

Pursuant to the ETSI IPR Policy, no investigation, including IPR searches, has been carried out by ETSI. No guarantee can be given as to the existence of other IPRs not referenced in ETSI SR 000 314 (or the updates on the ETSI Web server) which are, or may be, or may become, essential to the present document.

---

## Foreword

This Technical Specification (TS) has been produced by ETSI 3rd Generation Partnership Project (3GPP).

The present document may refer to technical specifications or reports using their 3GPP identities, UMTS identities or GSM identities. These should be interpreted as being references to the corresponding ETSI deliverables.

The cross reference between GSM, UMTS, 3GPP and ETSI identities can be found under <http://webapp.etsi.org/key/queryform.asp>.

---

## Modal verbs terminology

In the present document "**shall**", "**shall not**", "**should**", "**should not**", "**may**", "**need not**", "**will**", "**will not**", "**can**" and "**cannot**" are to be interpreted as described in clause 3.2 of the [ETSI Drafting Rules](#) (Verbal forms for the expression of provisions).

"**must**" and "**must not**" are **NOT** allowed in ETSI deliverables except when used in direct citation.

# Contents

Intellectual Property Rights .....	2
Foreword.....	2
Modal verbs terminology.....	2
Foreword.....	6
1 Scope .....	7
2 References .....	7
3 Definitions and abbreviations.....	9
3.1 Definitions .....	9
3.2 Abbreviations .....	9
4 General .....	10
5 Transport over ATM for BICC-based Nc .....	10
5.1 General .....	10
5.2 Transport network user plane .....	10
5.2.1 General.....	10
5.2.2 ATM Adaptation Layer 2 .....	10
5.2.2.1 AAL2-Segmentation and Reassembly Service Specific Convergence Sublayer .....	10
5.2.2.2 AAL2-specification.....	11
5.3 Transport network control plane .....	11
5.3.1 General.....	11
5.3.2 Signalling protocol.....	11
5.3.2.1 AAL2 Signalling Protocol.....	11
5.3.3 Signalling transport converter.....	11
5.3.3.1 AAL2 MTP3B Signalling Transport Converter .....	11
5.3.4 MTP3b .....	11
5.3.5 SSCF-NNI .....	11
5.3.6 SSCOP .....	11
5.3.7 ATM Adaptation Layer Type 5 .....	12
6 Transport over IP for BICC based Nc .....	12
6.1 General .....	12
6.2 Bearer Transport without multiplexing .....	12
6.2.0 Introduction.....	12
6.2.1 IP.....	12
6.2.2 UDP .....	12
6.2.3 RTP.....	12
6.2.3.1 RTP Header.....	13
6.2.3.1.1 Version .....	13
6.2.3.1.2 Padding.....	13
6.2.3.1.3 Extension .....	13
6.2.3.1.4 Contributing Source (CSRC) count.....	13
6.2.3.1.5 Marker Bit .....	13
6.2.3.1.6 Payload Type.....	13
6.2.3.1.7 Sequence Number.....	13
6.2.3.1.8 Timestamp .....	13
6.2.3.1.9 Synchronisation Source (SSRC).....	13
6.2.3.1.10 CSRC list.....	13
6.2.3.2 RTP Payload .....	13
6.2.4 RTCP .....	14
6.3 Bearer Control Protocol.....	14
6.3.1 Transport.....	14
6.3.2 Procedures.....	15
6.3.2.1 Bearer Establishment .....	15

6.3.2.2	Bearer Modification .....	15
6.3.2.3	Bearer Release.....	15
6.3.3	Use of IPBCP message fields .....	16
6.3.3.1	Origin .....	16
6.3.3.2	Session Name .....	16
6.3.3.3	Connection Data .....	16
6.3.3.4	Media Announcement .....	16
6.3.3.5	Media Attributes .....	16
6.4	Bearer Transport with multiplexing .....	17
6.4.1	Introduction.....	17
6.4.2	Transport format .....	17
6.4.2.1	IP.....	17
6.4.2.2	UDP.....	17
6.4.2.3	Transport Format for multiplexing without RTP Header Compression .....	17
6.4.2.4	Transport Format for multiplexing with RTP header compression.....	19
6.4.3	RTCP .....	21
6.4.3.1	General .....	21
6.4.3.2	Multiplex negotiation via RTCP .....	21
6.4.3.3	RTCP Multiplexing packet .....	22
7	Transport over IP for SIP-I based Nc.....	24
7.1	General .....	24
7.2	Bearer Transport without multiplexing .....	24
7.2.0	Introduction.....	24
7.2.1	IP.....	24
7.2.2	UDP .....	24
7.2.3	RTP.....	24
7.2.3.1	RTP Header.....	24
7.2.3.1.1	Version .....	24
7.2.3.1.2	Padding.....	24
7.2.3.1.3	Extension.....	24
7.2.3.1.4	Contributing Source (CSRC) count.....	24
7.2.3.1.5	Marker Bit .....	24
7.2.3.1.6	Payload Type .....	25
7.2.3.1.7	Sequence Number.....	25
7.2.3.1.8	Timestamp .....	25
7.2.3.1.9	Synchronisation Source (SSRC).....	25
7.2.3.1.10	CSRC list.....	25
7.2.3.2	RTP Payload .....	25
7.2.4	RTCP .....	25
7.3	Bearer Transport with multiplexing .....	25
7.3.1	Introduction.....	25
7.3.2	Transport format .....	25
7.3.2.1	IP.....	25
7.3.2.2	UDP.....	25
7.3.2.3	Transport Format for multiplexing without RTP Header Compression .....	25
7.3.2.4	Transport Format for multiplexing with RTP header compression.....	26
7.3.3	RTCP .....	27
7.4	Transcoder-less Interworking with the Iu Framing Protocol.....	27
7.4.1	Introduction.....	27
7.4.2	Initialisation .....	27
7.4.3	Time alignment.....	27
7.4.4	Rate control.....	28
7.4.4.1	General .....	28
7.4.4.2	Rate control for AMR and AMR-WB.....	28
7.4.4.3	Rate and Mode control for EVS.....	28
7.4.4.4	Interworking of rate control between compatible AMR-WB and EVS codec configurations .....	29
7.4.5	Frame quality indication .....	29
7.4.6	Framing.....	30
7.4.7	Transcoding .....	30
7.4.8	Discontinuous transmission .....	30
7.4.9	Timing and sequence information .....	30

**Annex A (informative):**    **Change history** .....31  
History .....32

---

# Foreword

This Technical Specification has been produced by the 3<sup>rd</sup> Generation Partnership Project (3GPP).

The contents of the present document are subject to continuing work within the TSG and may change following formal TSG approval. Should the TSG modify the contents of the present document, it will be re-released by the TSG with an identifying change of release date and an increase in version number as follows:

Version x.y.z

where:

- x the first digit:
  - 1 presented to TSG for information;
  - 2 presented to TSG for approval;
  - 3 or greater indicates TSG approved document under change control.
- y the second digit is incremented for all changes of substance, i.e. technical enhancements, corrections, updates, etc.
- z the third digit is incremented when editorial only changes have been incorporated in the document.

# 1 Scope

The present document specifies the bearer data transport and bearer control protocols used between MGWs within the CS core network across the Nb Interface. The present document assumes that the implementation of the split of the call control and the bearer transport and control, as specified in 3GPP TS 23.205 [1] with BICC-based Nc, and in 3GPP TS 23.231 [30] with SIP-I based Nc., see figure 1. For BICC-based Nc, the User Plane protocol that uses this bearer data transport (Nb UP) is described in 3GPP TS 29.415 [3]. The transport format for the Nb interface with IP transport can optionally allow RTP multiplexing. Note that the present document does not preclude an implementation of a combined MSC Server and MGW.

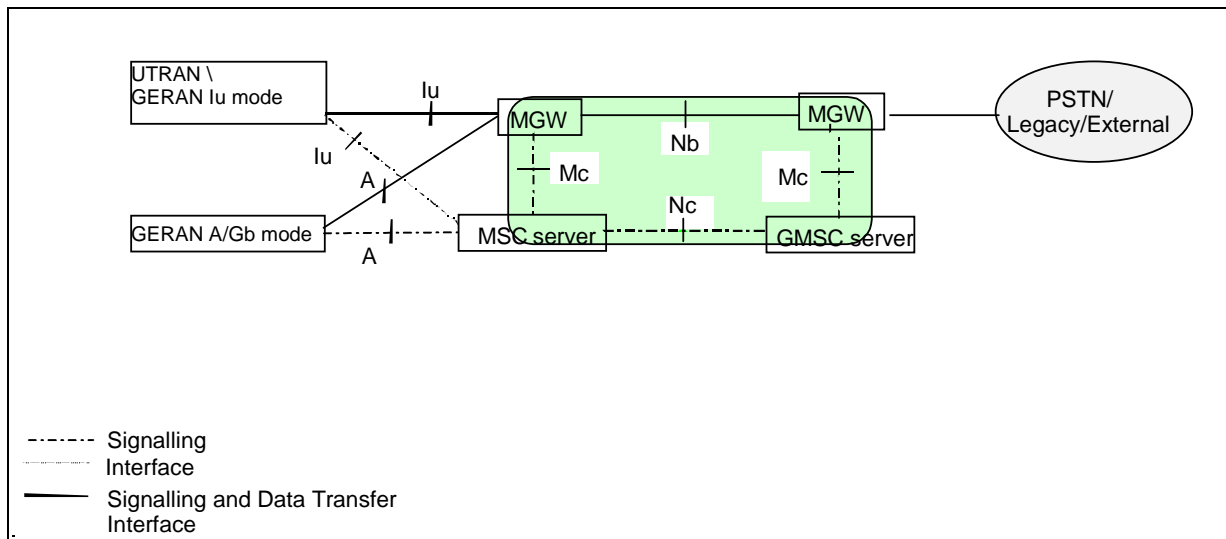

Figure 1: CS core network logical architecture

# 2 References

The following documents contain provisions which, through reference in this text, constitute provisions of the present document.

- References are either specific (identified by date of publication, edition number, version number, etc.) or non-specific.
- For a specific reference, subsequent revisions do not apply.
- For a non-specific reference, the latest version applies. In the case of a reference to a 3GPP document (including a GSM document), a non-specific reference implicitly refers to the latest version of that document in the same Release as the present document.

- [1] 3GPP TS 23.205: "Bearer Independent CS Core Network; Stage 2".
- [2] 3GPP TS 25.414: "UTRAN Iu Interface Data Transport and Transport Signalling".
- [3] 3GPP TS 29.415: "Core Network Nb Interface User Plane Protocols".
- [4] 3GPP TS 29.232: "Media Gateway Controller (MGC) – Media Gateway (MGW) Interface; Stage 3".
- [5] ITU-T Recommendation E.164 (5/1997): "Numbering Plan for the ISDN Era".
- [6] ITU-T Recommendation I.361 (2/1999): "B-ISDN ATM Layer Specification".
- [7] ITU-T Recommendation I.363.2 (11/2000): "B-ISDN ATM Adaptation Layer Type 2 Specification".



- [8] ITU-T Recommendation I.363.5 (8/1996): "B-ISDN ATM Adaptation Layer Type 5 Specification".
- [9] ITU-T Recommendation I.366.1 (6/1998): "Segmentation and Reassembly Service Specific Convergence Sublayer for the AAL Type 2".
- [10] ITU-T Recommendation H.248 (6/2000)"Media Gateway Control Protocol".
- [11] 3GPP TS 29.205: "Application of Q.1900 Series to Bearer Independent CS Core Network Architecture".
- [12] (Void)
- [13] (Void)
- [14] ITU-T Recommendation Q.2110 (7/1994): "B-ISDN ATM Adaptation Layer-Service Specific Connection Oriented Protocol (SSCOP)".
- [15] ITU-T Recommendation Q.2140 (2/1995): "B-ISDN ATM Adaptation Layer-Service Specific Coordination Function for Support of Signalling at the Network Node Interface (SSCF-NNI)".
- [16] ITU-T Recommendation Q.2150.1 (1999): "B-ISDN ATM Adaptation Layer-Signalling Transport Converter for the MTP3b".
- [17] ITU-T Recommendation Q.2210 (7/1996): "Message Transfer Part level 3 functions and messages using the services of ITU-T Recommendation Q.2140".
- [18] ITU-T Implementor's guide (12/99) for recommendation Q.2210 (07/96).
- [19] ITU-T Recommendation Q.2630.2 (12/2000): "AAL type 2 Signalling Protocol (Capability Set 2)".
- [20] ITU-T Recommendation Q.2931 (2/1995): "Digital Subscriber Signalling System No. 2 (DSS 2) – User-Network Interface (UNI) layer 3 specification for basic call/connection control".
- [21] ITU-T Recommendation X.213 (8/1997): "Information Technology-Open Systems Interconnection-Network Service Definitions".
- [22] IETF RFC 768: "User Datagram Protocol. (UDP)".
- [23] IETF RFC 791: "Internet Protocol (IP)".
- [24] IETF RFC 1889: "RTP: A Transport Protocol for Real Time Applications".
- [25] IETF RFC 1890: "RTP Profile for Audio and Video Conferences with Minimal Control".
- [26] IETF RFC 2327: "SDP: Session Description Protocol".
- [27] IETF RFC 2460: "Internet Protocol, Version 6 (IPv6)".
- [28] 3GPP TR 29.814: "Feasibility Study on Bandwidth Savings at Nb Interface with IP transport".
- [29] IETF RFC 3550: "RTP: A Transport Protocol for Real-Time Applications".
- [30] 3GPP TS 23.231: " SIP-I based circuit-switched core network; Stage 2".
- [31] 3GPP TS 25.415: "UTRAN Iu Interface User Plane Protocols"
- [32] 3GPP TS 26.102: "Adaptive Multi-Rate (AMR) speech codec; Interface to Iu and Uu".
- [33] IETF RFC 3551: "RTP Profile for Audio and Video Conferences with Minimal Control".
- [34] IETF RFC 3555: "MIME Type Registration of RTP Payload Formats".
- [35] IETF RFC 4867: "Real-Time Transport Protocol (RTP) payload format and file storage format for the Adaptive Multi-Rate (AMR) Adaptive Multi-Rate Wideband (AMR-WB) audio codecs".

- [36] 3GPP TS 29.007: "General requirements on interworking between the Public Land Mobile Network (PLMN) and the Integrated Services Digital Network (ISDN) or Public Switched Telephone Network (PSTN)" .
- [37] 3GPP TS 26.445: "Codec for Enhanced Voice Services (EVS); Detailed Algorithmic Description".
- [38] 3GPP TS 26.453: "Codec for Enhanced Voice Services (EVS); Speech codec frame structure".

---

## 3 Definitions and abbreviations

### 3.1 Definitions

For the purposes of the present document, the following terms and definitions apply.

### 3.2 Abbreviations

For the purposes of the present document, the following abbreviations apply:

AAL	ATM Adaptation Layer
AAL2	ATM Adaptation Layer Type 2
AAL5	ATM Adaptation Layer Type 5
AESA	ATM End System Address
ALC	AAL2 Link Characteristics
ARP	Address Resolution Protocol
ATM	Asynchronous Transfer Mode
AVP	Audio Video Profile
BICC	Bearer Independent Call Control
CMR	Codec Mode Request
CN	Core Network
CSRC	Contributing Source
DSS2	Digital Subscriber Signalling 2
EVS	Enhanced Voice Services
EVS-CMR	Codec Mode Request for EVS
IANA	Internet Assigned Numbering Authority
IP	Internet Protocol
IPv4	Internet Protocol version 4
IPv6	Internet Protocol version 6
IPBCP	IP Bearer Control Protocol
ITU-T	International Telecommunications Union-Telecommunication sector
IuFP	Iu Framing protocol
MGW	Media GateWay
MIME	Multi purpose Internet Mail Extension
MTP3b	Message Transfer Part level 3 for Q.2140 [15]
NNI	Network Node Interface
NSAP	Network Service Access Point
PDU	Protocol Data Unit
PVC	Permanent Virtual Circuit
RFC	Request For Comment
RTP	Real-Time Transport Protocol
RTCP	Real-Time Transport Control Protocol
SAR	Segmentation and Reassembly
SCCF-NNI	Service Specific Coordination Function-Network Node Interface
SDP	Session Description Protocol
SDU	Service Data Unit
SID	Silence Insertion Descriptor
SPVC	Switched PVC
SSSAR	Service Specific Segmentation and Re-assembly sublayer
SSCOP	Service Specific Connection Oriented Protocol

SSCS	Service Specific Convergence Sublayer
SSRC	Synchronisation Source
SVC	Switched Virtual Circuit
TrFO	Transcoder Free Operation
UDP	User Datagram Protocol
UNI	User Network Interface
UP	User Plane
VC	Virtual Circuit

---

## 4 General

The Nb UP shall be transported either over an ATM or IP bearer.

---

## 5 Transport over ATM for BICC-based Nc

### 5.1 General

Clause 5 is only applicable in combination with BICC-based Nc.

ATM shall be used in the transport network user plane and the transport network control plane according to ITU-T Recommendation I.361 [6]. The structure of the ATM cell header used across the Nb interface shall be the cell header format and encoding at the NNI (see Figure 3 in I.361 [6]).

### 5.2 Transport network user plane

#### 5.2.1 General

Figure 2 shows the ATM protocol stack used for the transport network user plane on the Nb interface.

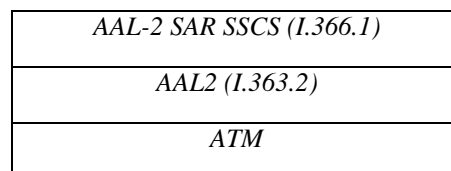

**Figure 2: ATM protocol stack used for the transport network user plane**

ATM AAL2 connections shall be transported over a VC which may either be a PVC, an SPVC or an SVC. For every ATM implementation of the Nb interface, a PVC shall be supported. The support of an SPVC or an SVC is optional. An ATM implementation may either support SPVCs only, SVCs only, or both.

If SPVCs or SVCs are supported, DSS2 signalling [20] shall be used for the establishment and tear down of these VCs. The network element that generated a given switched VC shall be the only network element that is allowed to tear down this VC.

#### 5.2.2 ATM Adaptation Layer 2

##### 5.2.2.1 AAL2-Segmentation and Reassembly Service Specific Convergence Sublayer

Service Specific Segmentation and Reassembly (SSSAR) sublayer of ITU-T Recommendation I.366.1 [9] shall be used for the segmentation and reassembly of AAL2 SDUs (i.e. only SSSAR is used from I.366.1 [9]).

### 5.2.2.2 AAL2-specification

AAL2 shall be used according to ITU-T Recommendation I.363.2 [7].

## 5.3 Transport network control plane

### 5.3.1 General

Figure 3 shows the protocol stack for the transport network control plane on the Nb interface.

<i>AAL2 connection signalling (Q.2630.2)</i>
<i>AAL2 Signalling Transport Converter for MTP3b (Q.2150.1)</i>
<i>MTP3b</i>
<i>SSCF-NNI</i>
<i>SSCOP</i>
<i>AAL5</i>
<i>ATM</i>

**Figure 3: ATM protocol stack for the transport network control plane**

Tunnelling, as described in 3GPP TS 23.205 [1], is currently not specified to transport the ATM transport network control plane.

### 5.3.2 Signalling protocol

#### 5.3.2.1 AAL2 Signalling Protocol

ITU-T Q.2630.2 [19] shall be used for the establishment of AAL2 connections. The AAL2 transport layer uses the embedded E.164 [5] or AESA variants of the NSAP addressing formats [21]. Native E.164 addressing shall not be used.

The MGW which issues a given ESTABLISH request [19] provides a Binding Reference (see 3GPP TS 23.205 [1]), This binding reference shall be copied into the SUGR parameter of the corresponding ESTABLISH request primitive [19].

The AAL2 Link Characteristics parameter (ALC) in the Establish Request message of the AAL2 signalling protocol shall be used.

### 5.3.3 Signalling transport converter

#### 5.3.3.1 AAL2 MTP3B Signalling Transport Converter

The AAL2 MTP3b Signalling Transport Converter shall be used according to ITU-T Recommendation Q.2150.1 [16].

### 5.3.4 MTP3b

MTP3b shall be used according to ITU-T Recommendation Q.2210 [17 & 18].

### 5.3.5 SSCF-NNI

SSCF-NNI shall be used according to ITU-T Recommendation Q.2140 [15].

### 5.3.6 SSCOP

SSCOP shall be used according to ITU-T Recommendation Q.2110 [14].

### 5.3.7 ATM Adaptation Layer Type 5

AAL5 shall be used according to ITU-T Recommendation I.363.5 [8]

---

## 6 Transport over IP for BICC based Nc

### 6.1 General

Clause 6 is only applicable in combination with BICC-based Nc.

RTP (RFC 1889 [24] or RFC 3550 [29]) over UDP (RFC 768 [22]) over either IPv4 (RFC 791 [23]) or IPv6 (RFC 2460 [27]) shall be used in the transport network user plane. The present specification takes the role of an RTP profile in describing the transport of the Nb UP protocol by RTP. Figure 4 shows the protocol stack for the transport network user plane on the Nb interface.

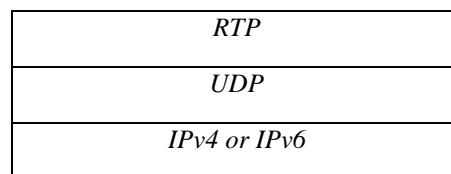

**Figure 4: IP Protocol stack for the transport network user plane**

Tunnelling, as described in 3GPP TS 23.205 [1], shall be used to transport the IP bearer control protocol IPBCP conform the ITU-T Recommendation Q.1970 "BICC IP Bearer Control Protocol" (IPBCP) (see 3GPP TS 29.205 [11]).

### 6.2 Bearer Transport without multiplexing

#### 6.2.0 Introduction

The support of bearer transport without multiplexing shall be supported. It shall be applied unless a bearer transport with multiplexing is negotiated via RTCP, as described in sub-clause 6.4.3.

#### 6.2.1 IP

Either IPv4 (RFC 791 [23]) or IPv6 (RFC 2460 [27]) shall be used.

One MGW may have several IP interfaces with different IP addresses.

#### 6.2.2 UDP

The UDP Protocol (see RFC 768 [22]) shall be applied.

Two consecutive port numbers shall be used at each MGW for the RTP bearer and for the optional RTCP connection that transport a single Nb UP connection. Two such consecutive port numbers are termed "port number block" in what follows. The first port number shall be even and shall be assigned to the RTP protocol. At a given MGW, the same port shall be used to send and to receive RTP PDUs. The next port number shall be assigned to the RTCP protocol. This port shall be reserved even if the optional RTCP protocol is not used.

Each MGW shall administer the port numbers it intends to use for RTP/RTCP port number blocks.

#### 6.2.3 RTP

RTP (see RFC 1889 [24] or RFC 3550 [29]) shall be applied.

### 6.2.3.1 RTP Header

The RTP Header Fields shall be used as described in the following subclauses:

#### 6.2.3.1.1 Version

RTP Version 2 shall be used.

#### 6.2.3.1.2 Padding

Padding shall not be used.

#### 6.2.3.1.3 Extension

The RTP Header shall not have an extension.

#### 6.2.3.1.4 Contributing Source (CSRC) count

There are zero CSRCs.

#### 6.2.3.1.5 Marker Bit

The marker bit is ignored.

#### 6.2.3.1.6 Payload Type

A dynamic Payload Type (see RFC 1890 [25]) shall be used. Values between 96 and 127 shall be used. The value shall be negotiated by means of the bearer control protocol.

#### 6.2.3.1.7 Sequence Number

The sequence number shall be supplied by the source MGW of a RTP PDU. The sink MGW of a RTP PDU may ignore the sequence number or it may use it to obtain statistics about the link quality and / or to correct out-of-sequence delivery, e.g. by dropping out-of-sequence packets.

#### 6.2.3.1.8 Timestamp

The timestamp shall be supplied by the source MGW of a RTP PDU. A clock frequency of 16000 Hz shall be used. The definition of the RTP timestamp is specified in IETF RFC 1889 [24] which states that RTP timestamp is based on the sampling instant of the source encoder. However for the present application the source MGW is not mandated to set the RTP timestamp according to the sampling instant of the payload PDU. Although the RTP timestamp can reflect the sampling instant in some scenarios, the sink MGW cannot rely upon the accuracy of the RTP Timestamp. The sink MGW of a RTP PDU may ignore the timestamp.

NOTE: An application can use the time based NbFP frame number to obtain end-to-end timing information.

#### 6.2.3.1.9 Synchronisation Source (SSRC)

The source MGW of a RTP PDU shall supply a SSRC. The sink MGW of a RTP PDU may ignore the SSRC if it does not use RTCP.

#### 6.2.3.1.10 CSRC list

This list is empty.

### 6.2.3.2 RTP Payload

A single UP PDU, as described in 3GPP TS 29.415 [3], shall be transported as a RTP payload.

## 6.2.4 RTCP

RTCP (see RFC 1889 [24]) may be applied. The use of the RTCP protocol is optional.

A MGW may ignore incoming RTCP PDUs.

Figure 5 shows the protocol stack for the transport of RTCP. The above Sections about IP and UDP shall also apply for the transport of RTCP.

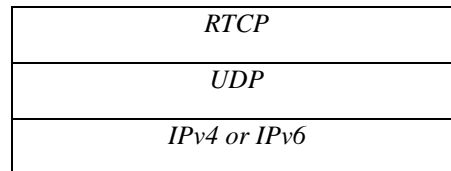

**Figure 5: RTCP Protocol stack for the transport network user plane**

## 6.3 Bearer Control Protocol

The ITU-T Recommendation Q.1970 "BICC IP Bearer Control Protocol" (IPBCP) (see 3GPP TS 29.205 [11]) shall be applied.

The use of Iu FP as RTP payload shall be indicated within IPBCP. IuFP shall transport either speech or data in a bearer independent way as described in 3GPP TS 23.205 and 3GPP TS 29.205. The negotiation of the type of payload within IuFP is outside the scope of IPBCP and described in the above specifications.

NOTE: The IuFP is registered with IANA as the MIME type "VND.3GPP.IuFP" of the "audio" category, however, this registration does not preclude the use of IuFP to transport "data".

### 6.3.1 Transport

IPBCP shall be transported over the Mc and Nc interface by means of the ITU-T Recommendation Q.1990 "BICC Bearer Control Tunnelling Protocol" ( see 3GPP TS 29.205 [11]). The transport of the Q.1990 "BICC Bearer Control Tunnelling Protocol" on the Mc interface is described in 3GPP TS 29.232 [4]. The transport of the "BICC Bearer Control Tunnelling Protocol" on the Nc interface is described in ITU-T Recommendation Q.765.5 (see 3GPP TS 29.205 [11]).

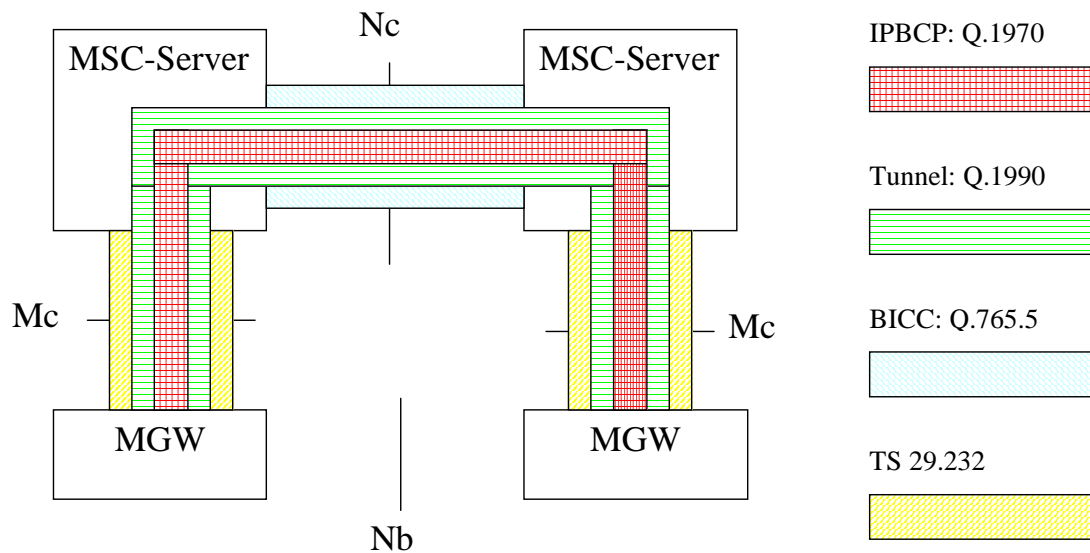

**Figure 6: Transport of IPBCP**

## 6.3.2 Procedures

The IPBCP procedures shall be used as described in the ITU-T Recommendation Q.1970 "BICC IP Bearer Control Protocol" (IPBCP) (see 3GPP TS 29.205 [11]).

### 6.3.2.1 Bearer Establishment

The forward and backward RTP bearers used to transport one Nb UP connection shall be set up together after an IPBCP handshake with a Request message and an Accepted message has succeeded.

Each MGW shall signal its peer MGW with the RTP port number. The RTCP port number shall be the next higher number.

If the optional 20 ms packetisation time is supported for PCM encoded speech over Nb and if its use is authorized by local configuration setting, the MGW shall also negotiate with its peer MGW the packetisation time to be used for PCM encoded speech over Nb, even if the codec configured on the bearer is still unknown or differs from PCM. This is done by including the "pcmptime=20" parameter in the IPBCP Request as defined in sub-clause 6.3.3.5. A MGW receiving the "pcmptime=20" parameter ignores it if the 20 ms packetisation time is not supported for PCM encoded speech over Nb. A MGW receiving the "pcmptime=20" parameter shall return the "pcmptime=20" parameter in the IPBCP Accept message only if the 20 ms packetisation is supported for PCM encoded speech over Nb and if its use is authorized by local configuration setting. Receipt of the "pcmptime=20" parameter in the IPBCP Accept shall indicate to the originating MGW that it shall apply the 20 ms packetisation time when PCM encoded speech is sent over the Nb bearer. Otherwise the default 5 ms packetisation time shall be used for PCM encoded speech over Nb. The result of the negotiation is only used if PCM is selected on the bearer.

### 6.3.2.2 Bearer Modification

A modification of existing RTP bearers is not permitted. The IPBCP Request message shall not be used to modify bearers.

### 6.3.2.3 Bearer Release

When the H.248 Termination [10] of an Nb UP connection on a MGW is deleted by means of signalling over the Mc interface, which are outside the scope of IPBCP (see 3GPP TS 29.232 [4]), the used resources shall be freed as follows:

The MGW shall discard any packets arriving at the port pair used for the old Nb UP connection until it sets up a new Nb UP connection on these ports. The MGW shall only reuse these ports after a time that is long enough to avoid that packets from the old connection still arrive.



### 6.3.3 Use of IPBCP message fields

The IPBCP message fields shall be used as described in the ITU-T Recommendation Q.1970 "BICC IP Bearer Control Protocol" (IPBCP) (see 3GPP TS 29.205 [11]) and SDP (RFC 2327 [26]). Moreover, the following subclauses shall be applied:

#### 6.3.3.1 Origin

*<address>* shall be the IP address assigned to the IP interface used for the RTP bearer on the source MGW of the present IPBCP message.

#### 6.3.3.2 Session Name

The source MGW shall supply an arbitrary string as *<session name>*. The sink MGW shall ignore this string.

#### 6.3.3.3 Connection Data

The *<connection address>* shall be identical to the above origin *<address>*

#### 6.3.3.4 Media Announcement

*<media>* shall always be set to "audio" irrespective of the payload type within IuFP.

*<port>* shall be set to the port number assigned to the RTP bearer on the source MGW of the present IPBCP message

*<transport>* shall be set to "RTP/AVP".

*<fmt list>* shall be set to the chosen dynamic payload number. The MGW that initiates the bearer establishment may choose any value between 96 and 127. The peer MGW shall echo this value.

#### 6.3.3.5 Media Attributes

The following media attribute shall be supplied: "a=rtpmap:*<dynamic payload number>* VND.3GPP.IUFP/16000", where:*<dynamic payload number>* is the same dynamic payload type number as in the above media announcement *<fmt list>*.

The media attribute "a=fmtp:*<format>* pcmptime=20" shall also be set:

- in the IPBCP Request if the optional 20 ms packetisation time is supported for PCM encoded speech over Nb and if its use is authorized by local configuration setting;
- in the IPBCP Accept message if received in the IPBCP Request and if the optional 20 ms packetisation time is supported for PCM encoded speech over Nb and if its use is authorized by local configuration setting.

Other media attributes shall not be used. They shall be ignored in the MGW receiving an IPBCP message.

Example of IPBCP Request / Accept exchange where both MGWs support the 20 ms packetisation time for PCM encoded speech over Nb:

```
IPBCP Request (MGW1 -> MGW2)
  m=audio 49170 RTP/AVP 97
  a=rtpmap:97 VND.3GPP.IUFP/16000
  a=fmtp:97 pcmptime=20
IPBCP Accept (MGW2 -> MGW1)
  m=audio 49320 RTP/AVP 97
  a=rtpmap:97 VND.3GPP.IUFP/16000
  a=fmtp:97 pcmptime=20
```

## 6.4 Bearer Transport with multiplexing

### 6.4.1 Introduction

This sub-clause specifies an optional transport format for the Nb interface and IP transport that allows transporting several RTP/NbFP/codec payload PDUs of different user plane connections within one packet, and the corresponding backward compatible signalling extensions required to negotiate the use of this transport option. Use of this transport format saves bandwidth in the IP network (bandwidth gains are evaluated in 3GPP TR 29.814 [28]).

Bandwidth saving is achieved by multiplexing several NbFP PDUs within one UDP/IP packet. As an option, the RTP header may be compressed in addition. Two transport formats are specified accordingly.

### 6.4.2 Transport format

#### 6.4.2.1 IP

Either IPv4 (RFC 791 [23]) or IPv6 (RFC 2460 [27]) shall be used.

One MGW may have several IP interfaces with different IP addresses.

#### 6.4.2.2 UDP

The UDP Protocol (see RFC 768 [22]) shall be applied. If multiplexing is applied with or without header compression, the source UDP port number shall indicate the local termination used to combine the multiplexed packet and the destination UDP port number shall indicate the remote port number where PDUs are demultiplexed. The negotiation if multiplexing is applied and of the destination UDP port is described in sub-clause 6.4.3. If multiplexing was negotiated for a Nb UP user plane connection, the MGW may apply multiplexing by sending all packets of the user plane connection towards the negotiated destination UDP port.

#### 6.4.2.3 Transport Format for multiplexing without RTP Header Compression

Several RTP/NbFP/codec payload PDUs sent to the same IP address are multiplexed within one single UDP/IP packet over the Nb interface between MGWs. If DiffServ is applied, all multiplexed PDUs also need to share the same DiffServ class. The multiplexing shall only be used with RTP packets. RTCP shall be transported normally by UDP/IP packets.

Use of multiplexing shall be negotiated between MGWs, as specified in sub-clause 6.4.3.

Before each multiplexed RTP/NbFP/codec payload PDU inserted into the UDP/IP packet a Multiplex Header, which identifies the multiplexed packet, shall be inserted.

Bits								Number of Octets	
7	6	5	4	3	2	1	0		
Source IP, Dest IP, ...								20/40	IP
Source Port, Dest Port=<MUX UDP port>, Length, ...								8	UDP
T=0		Mux ID = (Destination UDP Port of multiplexed PDU) / 2						2	Multiplex Header
Length Indicator (LI) = n								1	
R		Source ID = (Source UDP Port of multiplexed PDU) / 2						2	
Full RTP packet								n	RTP header RTP NbFP Payload
Multiplex Header								5	Multiplex Header
Full RTP packet								m	RTP header RTP NbFP Payload
...									

**Figure 7: UDP/IP Packet with multiplexed RTP/NbFP payload PDUs without RTP header compression**

The Multiplex Header includes :

- T bit.

The field has two possible values, 0 for indicating full packet and 1 for indicating compressed packet. Value 0 shall be used for an uncompressed RTP header, as described in the present sub-clause.

- Mux ID, 15 bits.

For identification of different user plane connections. The value shall be the UDP destination port of the corresponding non-multiplexed RTP/NbFP PDU packet divided by two (only even numbered ports are used for RTP sessions).

- Length Indicator (LI), 8 bits, unsigned integer.

Gives the length of the multiplexed RTP/NbFP PDU packet (RTP header + RTP Payload = RTP header + NbFP header + NbFP payload) in bytes (the last byte of the RTP/NbFP PDU is padded to the next byte boundary if necessary). Maximum length is 255 bytes. This LI allows to calculate where the next Multiplex Header for the next multiplexed RTP/NbFP PDU packet starts.

- R bit.

Reserved for future use. Shall be set to 0 by the sending entity and be ignored by the receiving entity.

- Source ID, 15 bits.

For identification of the different connections. The value shall be the source UDP port of the corresponding non-multiplexed RTP/NbFP/codec PDU packet divided by two (only even numbered ports are used for RTP sessions). This information is transferred to permit the receiving node to optionally detect and filter illegitimate packets (e.g. packets received from the peer termination precedingly associated to the receiving termination).

The multiplexed RTP/NbFP payload PDU shall be inserted in the IP/UDP packet directly after the corresponding Multiplex Header. The multiplexed RTP/NbFP payload PDU shall follow the rules in sub-clause 6.2.3 and consists of the full RTP header, the full NbFP header and the NbFP payload. If the multiplexed RTP/NbFP payload PDU does not end at a byte boundary, then the remaining bits of its last byte shall be padded with zeros.

The multiplexing method does not limit the number of packets being multiplexed and it is thus the data link layer protocol that defines the maximum frame size. E.g. an IP datagram has a maximum length of 65 535 bytes and Ethernet 1 518 bytes. In order to avoid additional delay in the network the packets should not be delayed more than 1 ms to 2 ms, which also effectively limits the number of multiplexed packets and makes the multiplexing-jitter low.

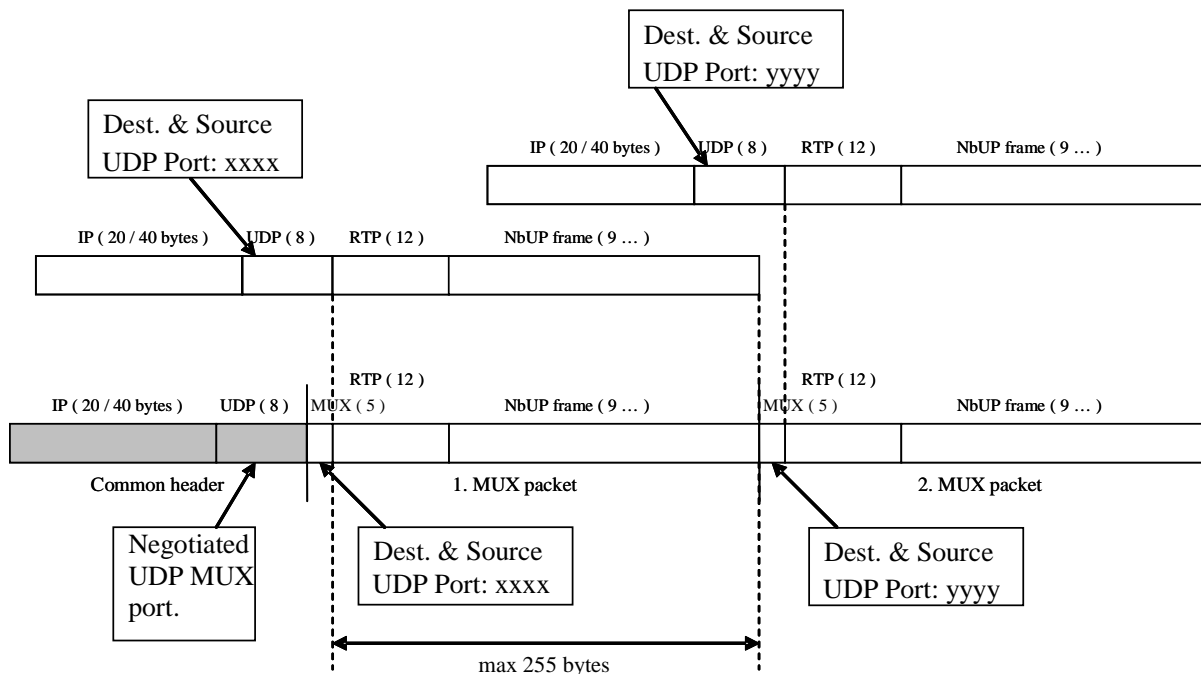

Figure 8: Example of multiplexed packet with two RTP frames

#### 6.4.2.4 Transport Format for multiplexing with RTP header compression

To achieve even better bandwidth savings, the RTP header may optionally be compressed. This is possible since the RTP header includes many static fields that remain unchanged during an RTP session if NbFP is used as payload (see sub-clause 6.3.2).

Use of RTP header compression shall be negotiated between MGWs, as specified in sub-clause 6.4.3.

At least the first two RTP packets of each RTP session shall be sent with their full RTP header to allow the receiver to store the full header and use it in decompression. RTP packets shall also be sent with their full RTP header till receipt of a RTCP packet from the peer indicating support of RTP header compression. Subsequent packets may be sent with a compressed RTP header. If a MGW does not receive any of the initial RTP packets with a full RTP header, the MGW shall assume that the fields of the RTP header other than those present in the compressed RTP header are set as defined in sub-clause 6.2.3.1, and shall therefore not consider this as an error.

Before each multiplexed RTP/NbFP/codec payload PDU inserted into the UDP/IP packet a Multiplex Header, which identifies the multiplexed packet, shall be inserted

Bits								Number of Octets	
7	6	5	4	3	2	1	0		
Source IP, Dest IP, ...								20/40	IP
Source Port, Dest Port=<MUX UDP port>, Length, ...								8	UDP
T=1	Mux ID = (Destination UDP Port of multiplexed PDU) / 2							2	Multiplex Header
Length Indicator (LI) = n + 3								1	
R	Source ID = (Source UDP Port of multiplexed PDU) / 2							2	
Sequence Number (SN)								1	Compressed RTP header
Timestamp (TS)								2	
RTP payload								n	RTP NbFP Payload
Multiplex Header								5	Multiplex Header
Compressed RTP header								3	Compressed RTP header
RTP payload								m	RTP NbFP Payload

**Figure 9: UDP/IP Packet with multiplexed RTP/NbFP payload PDUs with RTP header compression**

The Multiplex Header shall be used as described in sub-clause 6.4.2.3. However, the T bit shall be set for a compressed RTP header, as described in the present sub-clause. The Length Indicator gives the length of the multiplexed RTP/NbFP PDU packet in bytes (compressed RTP header + RTP Payload ).

The multiplexed RTP/NbFP payload PDU shall be inserted in the IP/UDP packet directly after the corresponding Multiplex Header. The multiplexed RTP/NbFP payload PDU shall consist of the compressed RTP header described below followed by the full NbFP header and the NbFP payload, as described in 3GPP TS 29.415 [3]. If the multiplexed RTP/NbFP payload PDU does not end at a byte boundary, then the remaining bits of its last byte shall be padded with zeros.

The compressed RTP header shall include the following two fields taken from the uncompressed RTP header:

- Sequence number (SN), 8 bits.

The field changes as the original sequence number (RFC 3550 [29]) but is shortened from 16 bits to 8 bits (256 packets). The least significant byte of the RTP sequence number shall be included. Sub-clause 6.2.3.1.7 is applicable.

- Timestamp (TS), 16 bits.

The TS field changes as the original timestamp (RFC 3550 [29]) but the length is half of the original resulting in modulo of 4 seconds with 16 kHz clock reference. The least significant two bytes of the RTP timestamp shall be included. Sub-clause 6.2.3.1.8 is applicable.

NOTE: These RTP fields change during a connection and thus need to be transferred within each packet for NbFP payload. All other RTP fields do not change (see sub-clause 6.2.3).

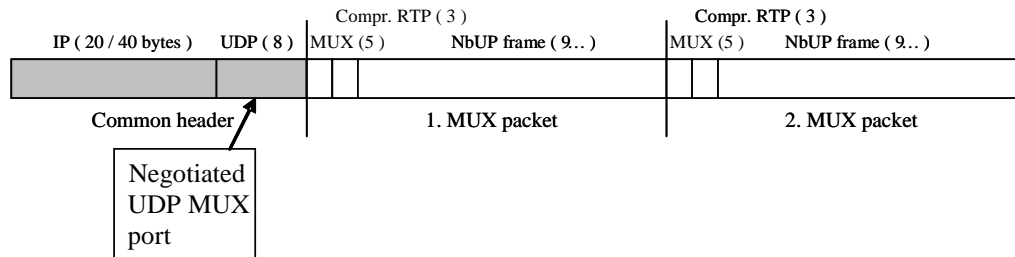

Figure 10: Example of multiplexed packet with two RTP frames and compressed RTP headers

## 6.4.3 RTCP

### 6.4.3.1 General

A MGW wishing to apply Bearer Transport with multiplexing shall use RTCP (see RFC 3550 [29]) to negotiate multiplexing.

RTCP shall be used separately for each user plane connection. RTCP shall be transported by UDP/IP packets as described in sub-clause 6.2.4. and not included in IP/UDP packets using the multiplexing format described above.

### 6.4.3.2 Multiplex negotiation via RTCP

RTCP shall be used to negotiate the use of multiplexing. A new 3GPP-specific RTCP Multiplexing packet is specified in sub-clause 6.4.3.3 for this purpose, and may be added to compound RTCP packets following the principles of RFC 3550 [29]. The Multiplexing RTCP packet indicates:

- if multiplexing without RTP header compression is supported ;
- if multiplexing with RTP header compression is supported ;
- the local UDP port where to receive multiplexed data streams,
- if multiplexing is selected..

When setting up a new user plane connection, both peer MGWs of a NbUP connection shall start to send data without applying multiplexing and may indicate their readiness to receive multiplexed data streams by including the new RTCP Multiplexing packet in the initial and all subsequent RTCP packets they send. A MGW shall always announce the same multiplexing capabilities and the same UDP port where to receive multiplexed data streams in all the RTCP Multiplexing packets it sends for a given RTP session. MGWs should preferably send their initial RTCP packet at the very beginning of the RTP session to be able to apply multiplexing as soon as possible. A MGW sending a Multiplexing packet indicating support of multiplexing shall be ready to receive multiplexed packets at the announced UDP port. A single UDP port for multiplexing shall be used per destination IP address.

A MGW receiving an RTCP packet, where the peer indicated its readiness to receive multiplexed data streams, may apply multiplexing to send the corresponding RTP data streams towards the sender of the RTCP packet. If the MGW decides to apply multiplexing, it can immediately start sending multiplexed data streams towards the corresponding

UDP multiplexing port announced in the received RTCP Multiplexing packet. The MGW shall indicate in subsequent RTCP Multiplexing packets if it applies multiplexing with or without header compression for the given user connection

A MGW that does not receive RTCP or receives RTCP without the RTCP Multiplexing packet shall continue to send data for the user connection without applying multiplexing.

A MGW that does not support multiplexing will ignore the unknown received RTCP Multiplexing package according to RTCP procedures and will continue to send data for the user connection without applying multiplexing.

Sending of a RTCP Multiplexing packet indicating readiness to receive multiplexed data streams does not necessarily mean that the MGW is ready to send multiplexed data streams, i.e. multiplexing may be applied on a single or on both directions for a given RTP session.

The applicable compressed header format is not negotiated using RTCP, but is determined by the fact if the Nb bearer is controlled via a SIP-I based Nc interface or a BICC based Nc interface. A MGW may support multiplexing of both RTP header compression formats on a same IP interface.

### 6.4.3.3 RTCP Multiplexing packet

The format of the RTCP Multiplexing packet is specified in figure 11.

Bits								Number of Octets	
7	6	5	4	3	2	1	0		
V=2		P	subtype					1	APP packet header
PT=APP=204								1	
Length								2	
SSRC/CSRC								4	
Name(ASCII)								4	
MUX	CP	Selection		Reserved=0000				2	Application dependent data
Reserved=00000000									
Reserved=0	Local MUX UDP port / 2							2	

**Figure 11: RTCP Multiplexing packet**

The APP packet header includes :

- version (V), 2 bits

Identifies the version of RTP, which is the same in RTCP packets as in RTP data packets. RTP Version 2 shall be used.

- padding (P), 1 bit

As specified in RFC 3550 [4].

- subtype, 5 bits.

The following subtype value shall be used :

00001 : RTCP Multiplexing packet

- packet type (PT), 8 bits.

Shall contains the constant 204 to identify this as an RTCP APP packet

- length, 16 bits.

As specified in RFC 3550 [4]. The length of this RTCP packet in 32-bit words minus one, including the header and any padding. (The offset of one makes zero a valid length and avoids a possible infinite loop in scanning a compound RTCP packet, while counting 32-bit words avoids a validity check for a multiple of 4.)

- SSRC/CSRC, 32 bits.

As specified in RFC 3550 [4].

- name, 32 bits.

Shall be set to "3GPP"

The application-dependent data includes :

- multiplexing bit (MUX), 1 bit

Indicates whether multiplexing without RTP header compression is supported or not by the sender of the RTCP packet : set to 0 if not supported, set to 1 if supported.

- multiplexing with RTP header compression bit (CP), 1 bit

Indicates whether multiplexing with RTP header compression is supported or not by the sender of the RTCP packet : set to 0 if not supported, set to 1 if supported.

- Selection bits, 2 bits

Indicates whether the sender of the RTCP packet has selected to apply multiplexing with or without header compression for the user plane packets that it sends on this connection. The following values are defined:

00: no multiplexing is applied

01: multiplexing is applied without RTP header compression

10: multiplexing is applied with RTP header compression

11: reserved

- Local MUX UDP port, 15 bits :

Local UDP port where the sender demands to receive multiplexed data streams. The value shall be the same as the local MUX UDP port divided by two. This parameter shall be ignored by the receiver of the RTCP Multiplexing packet if the MUX and CP bits indicate that multiplexing is not supported.

- Reserved bits:

Extension bits may be added in the RTCP Multiplexing packet in future releases. Reserved bits shall be set to 0 in sent RTCP Multiplexing packet of this release and shall be ignored in incoming RTCP Multiplexing packets.

Extension fields may be added in the RTCP Multiplexing packet in future releases. They shall be ignored by a MGW implementing an earlier version of the specification.



---

## 7 Transport over IP for SIP-I based Nc

### 7.1 General

Clause 7 is only applicable in combination with SIP-I based Nc.

IPv4 (RFC 791 [23]) shall be supported. IPv6 (RFC 2460 [27]) may be supported.

RTP (RFC 1889 [24] or RFC 3551 [29]) over UDP (RFC 768 [22]) over either IPv4 (RFC 791 [23]) or IPv6 (RFC 2460 [27]) shall be used in the transport network user plane. Figure 4 in Clause 6.1 shows the protocol stack for the transport network user plane on the Nb interface.

### 7.2 Bearer Transport without multiplexing

#### 7.2.0 Introduction

See 6.2.0

#### 7.2.1 IP

See 6.2.1

#### 7.2.2 UDP

See 7.2.2

#### 7.2.3 RTP

RTP (see RFC 1889 [24] or RFC 3550 [30]) shall be applied.

##### 7.2.3.1 RTP Header

The RTP Header Fields shall be used as described in the following subclauses:

###### 7.2.3.1.1 Version

RTP Version 2 shall be used.

###### 7.2.3.1.2 Padding

Padding shall not be used.

###### 7.2.3.1.3 Extension

The extension bit shall be used as specified for the RTP profile applicable for the used payload.

###### 7.2.3.1.4 Contributing Source (CSRC) count

There are zero CSRCs.

###### 7.2.3.1.5 Marker Bit

The marker bit shall be used as specified for the RTP profile applicable for the used payload.

#### 7.2.3.1.6 Payload Type

The payload type shall be set as negotiated by means of SIP-I and supplied over the Mc interface.

#### 7.2.3.1.7 Sequence Number

The sequence number shall be supplied by the source MGW of a RTP PDU.

#### 7.2.3.1.8 Timestamp

The timestamp shall be supplied by the source MGW of a RTP PDU.

#### 7.2.3.1.9 Synchronisation Source (SSRC)

The source MGW of a RTP PDU shall supply a SSRC.

#### 7.2.3.1.10 CSRC list

This list is empty.

### 7.2.3.2 RTP Payload

Speech in various encodings packed in corresponding RTP payload types may be transported as RTP Payload, as further specified in TS 26.102 [32]. Data and fax packed in corresponding RTP payload types may also be transported as RTP Payload, as further specified in 3GPP TS 29.007 [36].

NOTE: The Nb framing protocol specified in 3GPP TS 29.415 [3] is not applicable.

## 7.2.4 RTCP

The use of the RTCP (see RFC 1889 [24] or RFC 3551 [29]) protocol is optional, unless the RTP payload profile of the transported payload requires RTCP.

A MGW may ignore incoming RTCP PDUs, unless the RTP payload profile of the transported payload requires some usage of RTCP

Figure 5 in Clause 6.2.4 shows the protocol stack for the transport of RTCP. The above Sections about IP and UDP shall also apply for the transport of RTCP.

## 7.3 Bearer Transport with multiplexing

### 7.3.1 Introduction

See Clause 6.4.1

### 7.3.2 Transport format

#### 7.3.2.1 IP

See Clause 6.4.2.1

#### 7.3.2.2 UDP

See Clause 6.4.2.2

#### 7.3.2.3 Transport Format for multiplexing without RTP Header Compression

See Clause 6.4.2.3.

However, instead of RTP/NbFP/codec payload PDUs, RTP/codec payload PDUs shall be transported. The RTP header and the RTP payload shall follow the rules in sub-clause 7.2.3.

### 7.3.2.4 Transport Format for multiplexing with RTP header compression

RTP header compression for Nb bearers with SIP-I based Nc shall be applied as specified in sub-clause 6.4.2.4 for Nb bearers with BICC-based Nc, with the exceptions specified in the present Clause.

The transport format additionally includes the marker bit (bit M) and the payload type (PT), which can vary dependent on the transported payload.

Bits								Number of Octets	
7	6	5	4	3	2	1	0		
Source IP, Dest IP, ...								20/40	IP
Source Port, Dest Port=<MUX UDP port>, Length, ...								8	UDP
T=1	Mux ID = (Destination UDP Port of multiplexed PDU) / 2							2	Multiplex Header
Length Indicator (LI) = n+ 4								1	
R	Source ID = (Source UDP Port of multiplexed PDU) / 2							2	
Sequence Number (SN)								1	Compressed RTP header
Timestamp (TS)								2	
M	Payload Type (PT)							1	
RTP payload								n	RTP NbFP Payload
Multiplex Header								5	Multiplex Header
Compressed RTP header								4	Compressed RTP header
RTP payload								m	RTP NbFP Payload
...									

Figure 12: UDP/IP Packet with multiplexed RTP/Nb payload PDUs with RTP header compression

The compressed RTP header shall include the following fields taken from the uncompressed RTP header:

- Sequence number (SN), 8 bits.
- Timestamp (TS), 16 bits.
- Marker bit (M), 1 bit.
- Payload Type (PT), 7 bits

The usage of these header fields shall follow Clause 7.2.3

The Transport Format for multiplexing with RTP header compression shall not be applied for RTP payload types that use an RTP header extension. For RTP payload types that use an RTP header extension, this transport format shall not be offered or accepted in the RTCP multiplexing negotiation.

### 7.3.3 RTCP

See Clause 6.4.3

## 7.4 Transcoder-less Interworking with the Iu Framing Protocol

### 7.4.1 Introduction

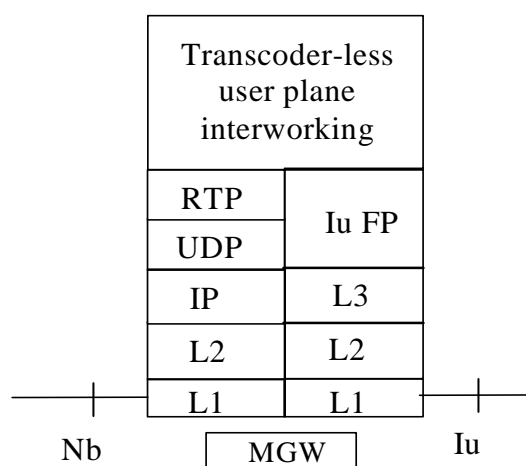

**Figure 13: Transcoder-less Interworking between IuFP and RTP (optional in the event the codecs on both sides are the same)**

If no transcoder is inserted, the MGW shall interwork the procedures between the RTP at the Nb interface of the SIP-I based CS CN and the Iu framing protocol (see 3GPP TS 25.415 [31]) at the Iu interface as described in the following Clauses.

### 7.4.2 Initialisation

There is no need to interwork IuFP initialisation procedures between Iu interface and the RTP at the Nb interface of the SIP-I based CS CN.

### 7.4.3 Time alignment

The purpose of the time alignment procedure on the Iu interface is to minimise the buffer delay in the RNC for downlink transmissions by adjusting the vocoder time reference within the network. No such procedure exists within RTP, so the MGW shall return NACK indication time alignment not supported according to 3GPP TS 25.415 [31].

## 7.4.4 Rate control

### 7.4.4.1 General

The rate control procedure signals to the peer entity the maximum rate among the currently allowed rates at which it can receive codec frames. Rate control only applies to AMR, AMR-WBand EVS codec configurations with multiple active modes. For the EVS codec, the rate control procedure also signals to the peer entity the maximum mode among the currently allowed modes at which it can receive codec frames.

### 7.4.4.2 Rate control for AMR and AMR-WB

For AMR and AMR-WB codecs:

- On the Iu interface, IuFP provides for rate control via the exchange of RATE CONTROL and RATE CONTROL ACK PDUs.
- On the Nb interface of the SIP-I based CS CN, RFC 4867 [35] provides for in-band rate control via the Codec Mode Request (CMR) field of every codec frame.
- Interworking of rate control procedures at an MGW between an Nb interface and a corresponding Iu interface only applies when the MGW bridges compatible codec configurations between the interfaces without applying a transcoding function.
- An MGW receiving a CMR from an Nb interface shall initiate the IuFP rate control procedure on the corresponding Iu interface.
- An MGW receiving a rate control request on an Iu interface shall adjust the CMR field of outgoing speech frames on the corresponding Nb interface.

### 7.4.4.3 Rate and Mode control for EVS

For the EVS codec:

- On the Iu interface, IuFP provides for rate control via the exchange of RATE CONTROL and RATE CONTROL ACK PDUs.
- On the Iu interface, CMR for EVS (EVS-CMR) as specified in 3GPP TS 26.453 [38] subclause 4.5 provides for in-band rate and mode control via the Codec Mode Request (CMR) field of every codec frame (Speech or SID) and CMR-Only frame.
- On the Nb interface of the SIP-I based CS CN, EVS-CMR as specified in 3GPP TS 26.453 [38] subclause 4.5 provides for in-band rate control via the Codec Mode Request (CMR) field of every codec frame.
- Interworking of rate control procedures at an MGW between an Nb interface and a corresponding Iu interface only applies when the MGW bridges compatible codec configurations between the interfaces without applying a transcoding function.
- An MGW receiving an EVS-CMR from an Nb interface may modify its contents based on local policies and include the resulting contents into the EVS-CMR field of the outgoing speech frame on the corresponding Iu interface.
- An MGW receiving a rate control request and an EVS-CMR on an Iu interface shall determine the lower limit of the maximum bit rates contained in each request and include the resulting limit into the EVS-CMR field of the outgoing speech frame on the corresponding Nb interface, with possible further modifications to the EVS-CMR contents based on configured policies.
- The rules by which the MGW may filter and modify the EVS-CMR contents consist of the following:
  - 1) The MGW shall not modify the EVS-CMR to increase the maximum bit rate;
  - 2) If the MGW observes the incoming stream of speech frames or packets and determines that a lower EVS mode is more appropriate, the MGW may modify the EVS-CMRs sent in the opposite direction of the observed speech flow;

- 3) If the MGW modifies the EVS-CMR to decrease the maximum bit rate and the resulting maximum bit rate no longer support the originally requested maximum audio bandwidth, then the maximum audio bandwidth may be reduced by the MGW to the next lower one that fits to the reduced maximum bit rate;
- 4) The MGW shall not modify the EVS-CMR in a way that results in a change of the major operation mode (EVS primary mode or EVS AMR-WB IO mode);

NOTE: The MGW can be forced to change the major operation mode of an incoming EVS-CMR when interworking between EVS and AMR-WB, during handover or after handover.

- 5) When channel-aware mode is used, if the MGW observes the incoming stream of speech frames or packets and determines that other channel-aware mode parameters are more appropriate, the MGW may modify the EVS-CMRs, flowing in the opposite direction of the observed speech flow to change the received channel-aware offset to a bigger one (e.g. from 2 to 3) and the received channel-aware depth to a lower, more robust one;
- 6) When channel-aware mode is used, the MGW shall not reduce the received channel-aware offset or modify the received channel-aware depth a less robust one;
- 7) The MGW should not block the channel-aware mode;
- 8) The MGW may modify the EVS primary mode in the received EVS-CMR to the EVS Variable Bit Rate mode.

#### 7.4.4.4 Interworking of rate control between compatible AMR-WB and EVS codec configurations

The EVS codec includes the EVS AMR-WB IO major operation mode and is therefore TrFO-compatible to the AMR-WB codec, if the mode-set and mode-change-period parameters are TrFO-compatible. For example, AMR-WB on one MGW termination and EVS on the other MGW termination are TrFO-compatible codecs, if the mode-set parameters are TrFO-compatible and mode-change-period=2 on both sides.

If the MGW bridges compatible EVS codec configurations and AMR-WB codec configurations:

- If the codec of the incoming termination is EVS and the codec of the outgoing termination is AMR-WB, then the rate control procedure for AMR-WB shall apply at the outgoing termination, with the maximum rate equal to or lower than the maximum rate received in the EVS-CMR. The MGW shall map received EVS-CMRs to the selected mode-set of the outgoing AMR-WB termination.

NOTE: In this interworking scenario, the incoming EVS-CMR should request AMR-WB IO mode of operation.

- If the codec of the incoming termination is AMR-WB and the codec of the outgoing termination is EVS, then the rate control procedure for AMR-WB shall apply on the incoming termination and shall determine the maximum rate included in the CMR sent by the MGW. The MWG shall request the EVS AMR-WB IO major operation mode in the outgoing CMR.
- The MGW may filter and modify the CMR contents according to the following rules:
  - 1) The MGW shall not modify the EVS-CMR to increase the maximum bit rate;
  - 2) If the MGW observes the incoming stream of speech frames or packets and determines that a lower EVS mode is more appropriate, the MGW may modify the EVS-CMRs sent in the opposite direction of the observed speech flow.

If the MGW bridges EVS codec configurations and AMR-WB codec configurations which are not compatible, the MGW shall apply transcoding and shall handle the independent rate and mode control procedures towards the incoming and the outgoing networks.

#### 7.4.5 Frame quality indication

The Iu framing protocol signals frame quality with the Frame Quality Classification (FQC) field of each speech frame PDU. See 3GPP TS 26.102 [32] and 3GPP TS 25.415 [31] for details. The FQC may have possible values: 0=frame\_good; 1=frame\_bad; 2=frame\_bad\_due\_to\_radio; and 3=spare. The RTP AMR, AMR-WB or EVS payload at

the Nb interface signals frame quality with the Q bit (frame quality indicator) field of each speech frame, as defined in RFC 4867 [35]. The Q bit may have values: 1=speech\_good; and 0=speech\_bad or sid\_bad.

Tables 1 and 2 provide the mapping between Nb and Iu interfaces.

**Table 1: Mapping of Nb RTP profile Qbit onto Iu FQC**

Nb RTP profile Qbit	Nb RTP profile FT	Iu - FQC
1	x	0
0	x	1

**Table 2: Mapping Iu FQC onto Nb RTP profile Qbit**

Iu - FQC	Nb RTP profile Qbit	Nb RTP profile FT
0	1	NC
1	0	NO_DATA
2	0	NC

## 7.4.6 Framing

Even when the MGW bridges compatible codec configurations between the Nb and Iu interfaces, the MGW shall perform translation between the frame formats defined for the two interfaces, since all codec configurations have different framing procedures for the two interfaces. The framing details for Iu are defined in 3GPP TS 26.102 [32] and 3GPP TS 25.415 [31], although they do not describe the framing for ITU-T codecs other than G.711. The framing details for Nb are defined in IETF RFC 4867 [35], IETF RFC 3550 [29], IETF RFC 3551 [33] and IETF RFC 3555 [34].

## 7.4.7 Transcoding

Transcoding at the MGW is avoided when the MGW bridges compatible codec configurations between the Nb and Iu interfaces. Otherwise transcoding is necessary, which eliminates the need to interwork other user plane procedures between the interfaces.

## 7.4.8 Discontinuous transmission

When the MGW bridges compatible codec configurations between the Nb and Iu interfaces, the DTX procedures are normally interworked transparently by translating between the framing formats on the interfaces. All the ITU-T, AMR, AMR-WB and EVS codecs have configurations that are compatible between the Iu and Nb interfaces.

For the AMR, AMR-WB and EVS codecs, DTX is always enabled on the CS radio Interface in the uplink direction and the transport channel for DTX in the downlink is always provided.

## 7.4.9 Timing and sequence information

The MGW shall always correct out-of-sequence delivery between Nb and Iu interfaces, either by re-ordering frames, or by dropping frames that are out of sequence.

When the IuFP frame numbers are based on time and if the MGW bridges compatible codec configurations between the Nb and Iu interfaces, it shall either correct jitter before forwarding PDUs or interwork the RTP timestamp (see RFC 3550 [29]) with the IuFP Frame Number (see 3GPP TS 25.415 [31]) so that both the RTP timestamp and IuFP frame number similarly reflect the nominal sampling instant of the user data in the packet.

NOTE: Correcting jitter may cause additional delay.

The RTP sequence number (see RFC 3550 [29]) is handled independently on Nb, i.e. it is not interworked with the IuFP Frame Number (see 3GPP TS 25.415 [31]).

## Annex A (informative): Change history

Change history							
Date	TSG #	TSG Doc.	CR	Rev	Subject/Comment	Old	New
03-2001	TSG#11	NP-010215			Approved as Version 4.0.0 to be placed under Change Control	2.1.0	4.0.0
06-2001	TSG#12	NP-010257	001		Editorial Clarifications in 29.414 and IANA registration	4.0.0	4.1.0
09-2001	TSG#13	NP-010439	003	2	Transport of data in the luFP	4.1.0	4.2.0
12-2001	TSG#14	NP-010573	004		Correction of inconsistency regarding RTP clock frequency	4.2.0	4.3.0
12-2001	TSG#14	NP-010573	005	1	Correction to Scope clause	4.2.0	4.3.0
03-2002	TSG#15	NP-020082	006		Update Reference to I.363.2	4.3.0	4.4.0
03-2002	TSG#15	NP-020085	007		Add GERAN lu mode to scope	4.3.0	5.0.0
04-2004	TSG#26				Upgraded to v6.0.0	5.0.0	6.0.0
12-2005	TSG#30	CP-050517	018	2	20 ms packetisation time for PCM coded speech over IP Nb	6.0.0	7.0.0
12-2006	TSG#34	CP-060620	026	2	RTP Timestamp	7.0.0	7.1.0
03-2007	TSG#35	CP-070106	027	3	Multiplexing at Nb interface with IP transport	7.1.0	7.2.0
03-2008	TSG#39	CP-080044	033	2	Adding RTP Transport used by SIP-I	7.2.0	8.0.0
05-2008	TSG#40	CP-080308	034	2	Mandatory support of Ipv4 on SIP-I based Nb interface	8.0.0	8.1.0
05-2008	TSG#40	CP-080309	035	2	Framing Protocol Interworking	8.0.0	8.1.0
12-2008	TSG#42	CP-080754	036	1	Reference to RTP payload types	8.1.0	8.2.0
03-2009	TSG#43	CP-090076	038		Corrections on description of multiplexing	8.2.0	8.3.0
12-2009	TSG#46				Automatic upgrade from previous Release	8.3.0	9.0.0
03-2011	TSG#51				Automatic upgrade from previous Release version 9.0.0	9.0.0	10.0.0
03-2011	TSG#51				Correction of heading and numbering made by MCC	10.0.0	10.0.1
04-2011	TSG#51				Further corrections	10.0.1	10.0.2
09-2012	TSG#57				Automatic upgrade from previous Release version 10.0.2	10.0.2	11.0.0
2014-10					Automatic upgrade from previous Release	11.0.0	12.0.0
2015-12	TSG#70	CP-150648	0039	3	Update of TS 29.414 to support EVS over UMTS CS	12.0.0	13.0.0

Change history							
Date	TSG #	TSG Doc.	CR	Rev	Cat	Subject/Comment	New
2016-03	CT#71	CP-160112	0040	1	B	Resolution of Editor's notes on EVS over UMTS CS	13.1.0
2016-12	CT#74	CP-160617	0041	1	F	Updates to EVS over CS aspects	13.2.0



---

# History

<b>Document history</b>		
V13.0.0	January 2016	Publication
V13.1.0	April 2016	Publication
V13.2.0	January 2017	Publication