

ETSI TS 129 503 V15.2.1 (2019-04)



**5G;
5G System;
Unified Data Management Services;
Stage 3
(3GPP TS 29.503 version 15.2.1 Release 15)**



Reference

RTS/TSGC-0429503vf21

Keywords

5G

ETSI

650 Route des Lucioles
F-06921 Sophia Antipolis Cedex - FRANCE

Tel.: +33 4 92 94 42 00 Fax: +33 4 93 65 47 16

Siret N° 348 623 562 00017 - NAF 742 C
Association à but non lucratif enregistrée à la
Sous-Préfecture de Grasse (06) N° 7803/88

Important notice

The present document can be downloaded from:

<http://www.etsi.org/standards-search>

The present document may be made available in electronic versions and/or in print. The content of any electronic and/or print versions of the present document shall not be modified without the prior written authorization of ETSI. In case of any existing or perceived difference in contents between such versions and/or in print, the prevailing version of an ETSI deliverable is the one made publicly available in PDF format at www.etsi.org/deliver.

Users of the present document should be aware that the document may be subject to revision or change of status.

Information on the current status of this and other ETSI documents is available at

<https://portal.etsi.org/TB/ETSIDeliverableStatus.aspx>

If you find errors in the present document, please send your comment to one of the following services:

<https://portal.etsi.org/People/CommitteeSupportStaff.aspx>

Copyright Notification

No part may be reproduced or utilized in any form or by any means, electronic or mechanical, including photocopying and microfilm except as authorized by written permission of ETSI.

The content of the PDF version shall not be modified without the written authorization of ETSI.

The copyright and the foregoing restriction extend to reproduction in all media.

© ETSI 2019.

All rights reserved.

DECT™, **PLUGTESTS™**, **UMTS™** and the ETSI logo are trademarks of ETSI registered for the benefit of its Members.

3GPP™ and **LTE™** are trademarks of ETSI registered for the benefit of its Members and of the 3GPP Organizational Partners.

oneM2M™ logo is a trademark of ETSI registered for the benefit of its Members and of the oneM2M Partners.

GSM® and the GSM logo are trademarks registered and owned by the GSM Association.

Intellectual Property Rights

Essential patents

IPRs essential or potentially essential to normative deliverables may have been declared to ETSI. The information pertaining to these essential IPRs, if any, is publicly available for **ETSI members and non-members**, and can be found in ETSI SR 000 314: *"Intellectual Property Rights (IPRs); Essential, or potentially Essential, IPRs notified to ETSI in respect of ETSI standards"*, which is available from the ETSI Secretariat. Latest updates are available on the ETSI Web server (<https://ipr.etsi.org/>).

Pursuant to the ETSI IPR Policy, no investigation, including IPR searches, has been carried out by ETSI. No guarantee can be given as to the existence of other IPRs not referenced in ETSI SR 000 314 (or the updates on the ETSI Web server) which are, or may be, or may become, essential to the present document.

Trademarks

The present document may include trademarks and/or tradenames which are asserted and/or registered by their owners. ETSI claims no ownership of these except for any which are indicated as being the property of ETSI, and conveys no right to use or reproduce any trademark and/or tradename. Mention of those trademarks in the present document does not constitute an endorsement by ETSI of products, services or organizations associated with those trademarks.

Foreword

This Technical Specification (TS) has been produced by ETSI 3rd Generation Partnership Project (3GPP).

The present document may refer to technical specifications or reports using their 3GPP identities, UMTS identities or GSM identities. These should be interpreted as being references to the corresponding ETSI deliverables.

The cross reference between GSM, UMTS, 3GPP and ETSI identities can be found under <http://webapp.etsi.org/key/queryform.asp>.

Modal verbs terminology

In the present document "**shall**", "**shall not**", "**should**", "**should not**", "**may**", "**need not**", "**will**", "**will not**", "**can**" and "**cannot**" are to be interpreted as described in clause 3.2 of the [ETSI Drafting Rules](#) (Verbal forms for the expression of provisions).

"**must**" and "**must not**" are **NOT** allowed in ETSI deliverables except when used in direct citation.

Contents

Intellectual Property Rights	2
Foreword.....	2
Modal verbs terminology.....	2
Foreword.....	11
1 Scope	12
2 References	12
3 Definitions and abbreviations.....	13
3.1 Definitions	13
3.2 Abbreviations	13
4 Overview	14
4.1 Introduction	14
5 Services offered by the UDM.....	14
5.1 Introduction	14
5.2 Nudm_SubscriberDataManagement Service.....	15
5.2.1 Service Description.....	15
5.2.2 Service Operations	15
5.2.2.1 Introduction.....	15
5.2.2.2 Get.....	15
5.2.2.2.1 General	15
5.2.2.2.2 Slice Selection Subscription Data Retrieval	16
5.2.2.2.3 Access and Mobility Subscription Data Retrieval	16
5.2.2.2.4 SMF Selection Subscription Data Retrieval	17
5.2.2.2.5 Session Management Subscription Data Retrieval	17
5.2.2.2.6 SMS Subscription Data Retrieval.....	18
5.2.2.2.7 SMS Management Subscription Data Retrieval	19
5.2.2.2.8 UE Context In SMF Data Retrieval.....	19
5.2.2.2.9 Retrieval Of Multiple Data Sets	20
5.2.2.2.10 Identifier Translation	20
5.2.2.2.11 Shared Subscription Data Retrieval.....	21
5.2.2.2.12 UE Context In SMSF Data Retrieval.....	21
5.2.2.3 Subscribe.....	22
5.2.2.3.1 General	22
5.2.2.3.2 Subscription to notifications of data change.....	22
5.2.2.3.3 Subscription to notifications of shared data change	22
5.2.2.4 Unsubscribe.....	23
5.2.2.4.1 General	23
5.2.2.4.2 Unsubscribe to notifications of data change.....	23
5.2.2.4.3 Unsubscribe to notifications of data change.....	24
5.2.2.5 Notification	24
5.2.2.5.1 General	24
5.2.2.5.2 Data Change Notification To NF.....	24
5.2.2.6 Info.....	25
5.2.2.6.1 General	25
5.2.2.6.2 Providing acknowledgement of Steering of Roaming	25
5.3 Nudm_UEContextManagement Service	25
5.3.1 Service Description.....	25
5.3.2 Service Operations.....	25
5.3.2.1 Introduction	25
5.3.2.2 Registration	26
5.3.2.2.1 General	26
5.3.2.2.2 AMF registration for 3GPP access	26
5.3.2.2.3 AMF registration for non 3GPP access	27
5.3.2.2.4 SMF registration.....	28
5.3.2.2.5 SMSF Registration for 3GPP Access	28
5.3.2.2.6 SMSF Registration for Non 3GPP Access	29
5.3.2.3 DeregistrationNotification.....	30

5.3.2.3.1	General	30
5.3.2.3.2	UDM initiated NF Deregistration	30
5.3.2.4	Deregistration	30
5.3.2.4.1	General	30
5.3.2.4.2	AMF deregistration for 3GPP access	30
5.3.2.4.3	AMF deregistration for non-3GPP access	31
5.3.2.4.4	SMF deregistration	31
5.3.2.4.5	SMSF Deregistration for 3GPP Access	32
5.3.2.4.6	SMSF Deregistration for Non 3GPP Access	32
5.3.2.5	Get	33
5.3.2.5.1	General	33
5.3.2.5.2	Amf3GppAccessRegistration Information Retrieval	33
5.3.2.5.3	AmfNon3GppAccessRegistration Information Retrieval	34
5.3.2.5.4	SmfRegistrations Information Retrieval	34
5.3.2.5.5	SmsfRegistration Information Retrieval for 3GPP Access	34
5.3.2.5.6	SmsfRegistration Information Retrieval for Non-3GPP Access	35
5.3.2.6	Update	35
5.3.2.6.1	General	35
5.3.2.6.2	Update A Parameter (e.g. PEI) in the AMF Registration For 3GPP Access	35
5.3.2.6.3	Update A Parameter (e.g. PEI) in the AMF Registration For Non 3GPP Access	36
5.3.2.7	P-CSCF-RestorationNotification	37
5.3.2.7.1	General	37
5.3.2.7.2	UDM initiated P-CSCF-Restoration	37
5.4	Nudm_UEAuthentication Service	37
5.4.1	Service Description	37
5.4.2	Service Operations	37
5.4.2.1	Introduction	37
5.4.2.2	Get	38
5.4.2.2.1	General	38
5.4.2.2.2	Authentication Information Retrieval	38
5.4.2.3	ResultConfirmationInform	38
5.4.2.3.1	General	38
5.4.2.3.2	Authentication Confirmation	38
5.5	Nudm_EventExposure Service	39
5.5.1	Service Description	39
5.5.2	Service Operations	39
5.5.2.1	Introduction	39
5.5.2.2	Subscribe	39
5.5.2.2.1	General	39
5.5.2.2.2	Subscription to Notification of event occurrence	40
5.5.2.3	Unsubscribe	40
5.5.2.3.1	General	40
5.5.2.3.2	Unsubscribe to notifications of event occurrence	41
5.5.2.4	Notify	41
5.5.2.4.1	General	41
5.5.2.4.2	Event Occurrence Notification	41
5.6	Nudm_ParameterProvision Service	42
5.6.1	Service Description	42
5.6.2	Service Operations	42
5.6.2.1	Introduction	42
5.6.2.2	Update	42
5.6.2.2.1	General	42
5.6.2.2.2	Subscription data update	42
6	API Definitions	43
6.1	Nudm_SubscriberDataManagement Service API	43
6.1.1	API URI	43
6.1.2	Usage of HTTP	43
6.1.2.1	General	43
6.1.2.2	HTTP standard headers	43
6.1.2.2.1	General	43
6.1.2.2.2	Content type	43

6.1.2.2.3	Cache-Control	43
6.1.2.2.4	ETag	43
6.1.2.2.5	If-None-Match	43
6.1.2.2.6	Last-Modified	44
6.1.2.2.7	If-Modified-Since	44
6.1.2.2.8	When to Use Entity-Tags and Last-Modified Dates	44
6.1.2.3	HTTP custom headers	44
6.1.2.3.1	General	44
6.1.3	Resources	44
6.1.3.1	Overview	44
6.1.3.2	Resource: Nssai	46
6.1.3.2.1	Description	46
6.1.3.2.2	Resource Definition	46
6.1.3.2.3	Resource Standard Methods	47
6.1.3.2.3.1	GET	47
6.1.3.3	Resource: SdmSubscriptions	47
6.1.3.3.1	Description	47
6.1.3.3.2	Resource Definition	47
6.1.3.3.3	Resource Standard Methods	48
6.1.3.3.3.1	POST	48
6.1.3.4	Resource: Individual subscription	48
6.1.3.4.1	Description	48
6.1.3.4.2	Resource Definition	48
6.1.3.4.3	Resource Standard Methods	49
6.1.3.4.3.1	DELETE	49
6.1.3.5	Resource: AccessAndMobilitySubscriptionData	49
6.1.3.5.1	Description	49
6.1.3.5.2	Resource Definition	49
6.1.3.5.3	Resource Standard Methods	49
6.1.3.5.3.1	GET	49
6.1.3.6	Resource: SmfSelectionSubscriptionData	50
6.1.3.6.1	Description	50
6.1.3.6.2	Resource Definition	50
6.1.3.6.3	Resource Standard Methods	50
6.1.3.6.3.1	GET	50
6.1.3.7	Resource: UeContextInSmfData	51
6.1.3.7.1	Description	51
6.1.3.7.2	Resource Definition	51
6.1.3.7.3	Resource Standard Methods	51
6.1.3.7.3.1	GET	51
6.1.3.8	Resource: SessionManagementSubscriptionData	52
6.1.3.8.1	Description	52
6.1.3.8.2	Resource Definition	52
6.1.3.8.3	Resource Standard Methods	52
6.1.3.8.3.1	GET	52
6.1.3.9	Resource: SMSSubscriptionData	53
6.1.3.9.1	Description	53
6.1.3.9.2	Resource Definition	53
6.1.3.9.3	Resource Standard Methods	53
6.1.3.9.3.1	GET	53
6.1.3.10	Resource: SMSManagementSubscriptionData	54
6.1.3.10.1	Description	54
6.1.3.10.2	Resource Definition	54
6.1.3.10.3	Resource Standard Methods	54
6.1.3.10.3.1	GET	54
6.1.3.11	Resource: Supi	55
6.1.3.11.1	Description	55
6.1.3.11.2	Resource Definition	55
6.1.3.11.3	Resource Standard Methods	55
6.1.3.11.3.1	GET	55
6.1.3.12	Resource: IdTranslationResult	56
6.1.3.12.1	Description	56

6.1.3.12.2	Resource Definition	56
6.1.3.12.3	Resource Standard Methods	56
6.1.3.12.3.1	GET	56
6.1.3.13	Resource: SorAck	57
6.1.3.13.1	Description	57
6.1.3.13.2	Resource Definition	57
6.1.3.13.3	Resource Standard Methods	57
6.1.3.13.3.1	PUT	57
6.1.3.14	Resource: TraceData	58
6.1.3.14.1	Description	58
6.1.3.14.2	Resource Definition	58
6.1.3.14.3	Resource Standard Methods	58
6.1.3.14.3.1	GET	58
6.1.3.15	Resource: SharedData	58
6.1.3.15.1	Description	58
6.1.3.15.2	Resource Definition	59
6.1.3.15.3	Resource Standard Methods	59
6.1.3.15.3.1	GET	59
6.1.3.16	Resource: SharedDataSubscriptions	59
6.1.3.16.1	Description	59
6.1.3.16.2	Resource Definition	59
6.1.3.16.3	Resource Standard Methods	60
6.1.3.16.3.1	POST	60
6.1.3.17	Resource: Individual subscription	60
6.1.3.17.1	Description	60
6.1.3.17.2	Resource Definition	60
6.1.3.17.3	Resource Standard Methods	60
6.1.3.17.3.1	DELETE	60
6.1.3.18	Resource: UeContextInSmsfData	61
6.1.3.18.1	Description	61
6.1.3.18.2	Resource Definition	61
6.1.3.18.3	Resource Standard Methods	61
6.1.3.18.3.1	GET	61
6.1.4	Custom Operations without associated resources	62
6.1.5	Notifications	62
6.1.5.1	General	62
6.1.5.2	Data Change Notification	62
6.1.6	Data Model	63
6.1.6.1	General	63
6.1.6.2	Structured data types	65
6.1.6.2.1	Introduction	65
6.1.6.2.2	Type: Nssai	65
6.1.6.2.3	Type: SdmSubscription	66
6.1.6.2.4	Type: AccessAndMobilitySubscriptionData	67
6.1.6.2.5	Type: SmfSelectionSubscriptionData	68
6.1.6.2.6	Type: DnnInfo	68
6.1.6.2.7	Type: SnssaiInfo	68
6.1.6.2.8	Type: SessionManagementSubscriptionData	69
6.1.6.2.9	Type: DnnConfiguration	69
6.1.6.2.10	Void	69
6.1.6.2.11	Type: PduSessionTypes	69
6.1.6.2.12	Type: SscModes	70
6.1.6.2.13	Type: SmsSubscriptionData	70
6.1.6.2.14	Type: SmsManagementSubscriptionData	70
6.1.6.2.15	Type: SubscriptionDataSets	71
6.1.6.2.16	Type: UeContextInSmfData	71
6.1.6.2.17	Type: PduSession	71
6.1.6.2.18	Type: IdTranslationResult	71
6.1.6.2.19	Void	71
6.1.6.2.20	Void	71
6.1.6.2.21	Type: ModificationNotification	71
6.1.6.2.22	Type: IpAddress	72

6.1.6.2.23	Type: UeContextInSmsfData	72
6.1.6.2.24	Type: SmsfInfo	72
6.1.6.2.25	Type: AcknowledgeInfo	72
6.1.6.2.26	Type: SorInfo	72
6.1.6.2.27	Type: SharedData	73
6.1.6.2.28	Type: PgwInfo	73
6.1.6.2.29	Type: TraceDataResponse	73
6.1.6.2.30	Type: SteeringContainer	73
6.1.6.3	Simple data types and enumerations	74
6.1.6.3.1	Introduction	74
6.1.6.3.2	Simple data types	74
6.1.6.3.3	Enumeration: DataSetName	75
6.1.6.3.4	Void	75
6.1.6.3.5	Void	75
6.1.6.3.6	Void	75
6.1.7	Error Handling	75
6.1.7.1	General	75
6.1.7.2	Protocol Errors	75
6.1.7.3	Application Errors	75
6.1.8	Feature Negotiation	76
6.1.9	Security	76
6.2	Nudm_UEContextManagement Service API	76
6.2.1	API URI	76
6.2.2	Usage of HTTP	76
6.2.2.1	General	76
6.2.2.2	HTTP standard headers	76
6.2.2.2.1	General	76
6.2.2.2.2	Content type	77
6.2.2.3	HTTP custom headers	77
6.2.2.3.1	General	77
6.2.3	Resources	77
6.2.3.1	Overview	77
6.2.3.2	Resource: Amf3GppAccessRegistration	78
6.2.3.2.1	Description	78
6.2.3.2.2	Resource Definition	78
6.2.3.2.3	Resource Standard Methods	79
6.2.3.2.3.1	PUT	79
6.2.3.2.3.2	PATCH	79
6.2.3.2.3.3	GET	80
6.2.3.3	Resource: AmfNon3GppAccessRegistration	80
6.2.3.3.1	Description	80
6.2.3.3.2	Resource Definition	81
6.2.3.3.3	Resource Standard Methods	81
6.2.3.3.3.1	PUT	81
6.2.3.3.3.2	PATCH	81
6.2.3.3.3.3	GET	82
6.2.3.4	Resource: SmfRegistrations	83
6.2.3.4.1	Description	83
6.2.3.4.2	Resource Definition	83
6.2.3.4.3	Resource Standard Methods	83
6.2.3.5	Resource: IndividualSmfRegistration	83
6.2.3.5.1	Resource Definition	83
6.2.3.5.2	Resource Standard Methods	83
6.2.3.5.2.1	PUT	83
6.2.3.5.2.2	DELETE	84
6.2.3.6	Resource: Smsf3GppAccessRegistration	84
6.2.3.6.1	Description	84
6.2.3.6.2	Resource Definition	84
6.2.3.6.3	Resource Standard Methods	85
6.2.3.6.3.1	PUT	85
6.2.3.6.3.2	DELETE	85
6.2.3.6.3.3	GET	86

6.2.3.7	Resource: SmsfNon3GppAccessRegistration	86
6.2.3.7.1	Description	86
6.2.3.7.2	Resource Definition	86
6.2.3.7.3	Resource Standard Methods	87
6.2.3.7.3.1	PUT	87
6.2.3.7.3.2	DELETE	87
6.2.3.7.3.3	GET	88
6.2.4	Custom Operations without associated resources	88
6.2.5	Notifications	88
6.2.5.1	General	88
6.2.5.2	Deregistration Notification	88
6.2.5.3	P-CSCF Restoration Notification	89
6.2.6	Data Model	90
6.2.6.1	General	90
6.2.6.2	Structured data types	90
6.2.6.2.1	Introduction	90
6.2.6.2.2	Type: Amf3GppAccessRegistration	91
6.2.6.2.3	Type: AmfNon3GppAccessRegistration	92
6.2.6.2.4	Type: SmfRegistration	93
6.2.6.2.5	Type: DeregistrationData	93
6.2.6.2.6	Type: SmsfRegistration	93
6.2.6.2.7	Type: Amf3GppAccessRegistrationModification	93
6.2.6.2.8	Type: AmfNon3GppAccessRegistrationModification	94
6.2.6.2.9	Type: PcsfRestorationNotification	94
6.2.6.2.10	Type: NetworkNodeDiameterAddress	95
6.2.6.3	Simple data types and enumerations	95
6.2.6.3.1	Introduction	95
6.2.6.3.2	Simple data types	95
6.2.6.3.3	Enumeration: DeregistrationReason	95
6.2.6.3.4	Enumeration: ImsVoPs	95
6.2.7	Error Handling	96
6.2.7.1	General	96
6.2.7.2	Protocol Errors	96
6.2.7.3	Application Errors	96
6.2.8	Feature Negotiation	96
6.2.9	Security	96
6.3	Nudm_UEAuthentication Service API	97
6.3.1	API URI	97
6.3.2	Usage of HTTP	97
6.3.2.1	General	97
6.3.2.2	HTTP standard headers	97
6.3.2.2.1	General	97
6.3.2.2.2	Content type	97
6.3.2.3	HTTP custom headers	97
6.3.2.3.1	General	97
6.3.3	Resources	97
6.3.3.1	Overview	97
6.3.3.2	Resource: SecurityInformation	98
6.3.3.2.1	Description	98
6.3.3.2.2	Resource Definition	98
6.3.3.2.3	Resource Standard Methods	99
6.3.3.2.4	Resource Custom Operations	99
6.3.3.2.4.1	Overview	99
6.3.3.2.4.2	Operation: generate-auth-data	99
6.3.3.2.4.2.1	Description	99
6.3.3.2.4.2.2	Operation Definition	99
6.3.3.3	Resource: AuthEvents	100
6.3.3.3.1	Description	100
6.3.3.3.2	Resource Definition	100
6.3.3.3.3	Resource Standard Methods	100
6.3.3.3.3.1	POST	100
6.3.4	Custom Operations without associated resources	101

6.3.5	Notifications	101
6.3.6	Data Model	101
6.3.6.1	General	101
6.3.6.2	Structured data types	101
6.3.6.2.1	Introduction	101
6.3.6.2.2	Type: AuthenticationInfoRequest	102
6.3.6.2.3	Type: AuthenticationInfoResult	102
6.3.6.2.4	Type: AvEapAkaPrime	102
6.3.6.2.5	Type: Av5GHeAka	102
6.3.6.2.6	Type: ResynchronizationInfo	102
6.3.6.2.7	Type: AuthEvent	103
6.3.6.2.8	Type: AuthenticationVector	103
6.3.6.3	Simple data types and enumerations	103
6.3.6.3.1	Introduction	103
6.3.6.3.2	Simple data types	103
6.3.6.3.3	Enumeration: AuthType	103
6.3.6.3.4	Enumeration: AvType	104
6.3.7	Error Handling	104
6.3.7.1	General	104
6.3.7.2	Protocol Errors	104
6.3.7.3	Application Errors	104
6.3.8	Feature Negotiation	104
6.3.9	Security	104
6.4	Nudm_EventExposure Service API	105
6.4.1	API URI	105
6.4.2	Usage of HTTP	105
6.4.2.1	General	105
6.4.2.2	HTTP standard headers	105
6.4.2.2.1	General	105
6.4.2.2.2	Content type	105
6.4.2.3	HTTP custom headers	105
6.4.2.3.1	General	105
6.4.3	Resources	106
6.4.3.1	Overview	106
6.4.3.2	Resource: EeSubscriptions	106
6.4.3.2.1	Description	106
6.4.3.2.2	Resource Definition	106
6.4.3.2.3	Resource Standard Methods	107
6.4.3.2.3.1	POST	107
6.4.3.3	Resource: Individual subscription	108
6.4.3.3.1	Resource Definition	108
6.4.3.3.2	Resource Standard Methods	108
6.4.3.3.2.1	DELETE	108
6.4.4	Custom Operations without associated resources	108
6.4.5	Notifications	109
6.4.5.1	General	109
6.4.5.2	Event Occurrence Notification	109
6.4.6	Data Model	109
6.4.6.1	General	109
6.4.6.2	Structured data types	110
6.4.6.2.1	Introduction	110
6.4.6.2.2	Type: EeSubscription	110
6.4.6.2.3	Type: MonitoringConfiguration	110
6.4.6.2.4	Type: MonitoringReport	111
6.4.6.2.5	Type: Report	111
6.4.6.2.6	Type: ReportingOptions	111
6.4.6.2.7	Type: ChangeOfSupiPeiAssociationReport	111
6.4.6.2.8	Type: RoamingStatusReport	112
6.4.6.2.9	Type: CreatedEeSubscription	112
6.4.6.2.10	Type: LocationReportingConfiguration	112
6.4.6.3	Simple data types and enumerations	112
6.4.6.3.1	Introduction	112

6.4.6.3.2	Simple data types.....	112
6.4.6.3.3	Enumeration: EventType.....	113
6.4.6.3.4	Enumeration: LocationAccuracy.....	113
6.4.7	Error Handling.....	113
6.4.7.1	General.....	113
6.4.7.2	Protocol Errors.....	113
6.4.7.3	Application Errors.....	113
6.4.8	Feature Negotiation.....	114
6.4.9	Security.....	114
6.5	Nudm_ParameterProvision Service API.....	114
6.5.1	API URI.....	114
6.5.2	Usage of HTTP.....	114
6.5.2.1	General.....	114
6.5.2.2	HTTP standard headers.....	114
6.5.2.2.1	General.....	114
6.5.2.2.2	Content type.....	114
6.5.2.3	HTTP custom headers.....	115
6.5.2.3.1	General.....	115
6.5.3	Resources.....	115
6.5.3.1	Overview.....	115
6.5.3.2	Resource: PpData.....	115
6.5.3.2.1	Description.....	115
6.5.3.2.2	Resource Definition.....	115
6.5.3.2.3	Resource Standard Methods.....	115
6.5.3.2.3.1	PATCH.....	115
6.5.4	Custom Operations without associated resources.....	116
6.5.5	Notifications.....	116
6.5.6	Data Model.....	116
6.5.6.1	General.....	116
6.5.6.2	Structured data types.....	117
6.5.6.2.1	Introduction.....	117
6.5.6.2.2	Type: PpData.....	117
6.5.6.2.3	Type: CommunicationCharacteristics.....	117
6.5.6.2.4	Type: PpSubsRegTimer.....	117
6.5.6.2.5	Type: PpActiveTime.....	117
6.5.6.3	Simple data types and enumerations.....	117
6.5.6.3.1	Introduction.....	117
6.5.6.3.2	Simple data types.....	118
6.5.6.3.3	Enumeration: <EnumType1>.....	118
6.5.7	Error Handling.....	118
6.5.7.1	General.....	118
6.5.7.2	Protocol Errors.....	118
6.5.7.3	Application Errors.....	118
6.5.8	Feature Negotiation.....	118
6.5.9	Security.....	118
Annex A (normative):	OpenAPI specification.....	120
A.1	General.....	120
A.2	Nudm_SDM API.....	120
A.3	Nudm_UECM API.....	139
A.4	Nudm_UEAU API.....	152
A.5	Nudm_EE API.....	156
A.6	Nudm_PP API.....	160
Annex B (informative):	Stateless UDMs.....	162
Annex C (informative):	SUCI encoding.....	165
Annex D (informative):	Change history.....	168
History.....		172

Foreword

This Technical Specification has been produced by the 3rd Generation Partnership Project (3GPP).

The contents of the present document are subject to continuing work within the TSG and may change following formal TSG approval. Should the TSG modify the contents of the present document, it will be re-released by the TSG with an identifying change of release date and an increase in version number as follows:

Version x.y.z

where:

- x the first digit:
 - 1 presented to TSG for information;
 - 2 presented to TSG for approval;
 - 3 or greater indicates TSG approved document under change control.
- y the second digit is incremented for all changes of substance, i.e. technical enhancements, corrections, updates, etc.
- z the third digit is incremented when editorial only changes have been incorporated in the document.

1 Scope

The present document specifies the stage 3 protocol and data model for the Nudm Service Based Interface. It provides stage 3 protocol definitions and message flows, and specifies the API for each service offered by the UDM.

The 5G System stage 2 architecture and procedures are specified in 3GPP TS 23.501 [2] and 3GPP TS 23.502 [3].

The Technical Realization of the Service Based Architecture and the Principles and Guidelines for Services Definition are specified in 3GPP TS 29.500 [4] and 3GPP TS 29.501 [5].

2 References

The following documents contain provisions which, through reference in this text, constitute provisions of the present document.

- References are either specific (identified by date of publication, edition number, version number, etc.) or non-specific.
- For a specific reference, subsequent revisions do not apply.
- For a non-specific reference, the latest version applies. In the case of a reference to a 3GPP document (including a GSM document), a non-specific reference implicitly refers to the latest version of that document *in the same Release as the present document*.

- [1] 3GPP TR 21.905: "Vocabulary for 3GPP Specifications".
- [2] 3GPP TS 23.501: "System Architecture for the 5G System; Stage 2".
- [3] 3GPP TS 23.502: "Procedures for the 5G System; Stage 2".
- [4] 3GPP TS 29.500: "5G System; Technical Realization of Service Based Architecture; Stage 3".
- [5] 3GPP TS 29.501: "5G System; Principles and Guidelines for Services Definition; Stage 3".
- [6] 3GPP TS 33.501: "Security Architecture and Procedures for 5G System".
- [7] 3GPP TS 29.571: "5G System; Common Data Types for Service Based Interfaces Stage 3".
- [8] 3GPP TS 23.003: "Numbering, addressing and identification".
- [9] 3GPP TS 29.504: "5G System; Unified Data Repository Services; Stage 3".
- [10] 3GPP TS 29.505: "5G System; Usage of the Unified Data Repository Services for Subscription Data; Stage 3".
- [11] 3GPP TS 32.251: "Charging management; Packet Switched (PS) domain charging".
- [12] 3GPP TS 32.298: "Charging management; Charging Data Record (CDR) parameter description".
- [13] IETF RFC 7540: "Hypertext Transfer Protocol Version 2 (HTTP/2)".
- [14] OpenAPI Initiative, "OpenAPI 3.0.0 Specification", <https://github.com/OAI/OpenAPI-Specification/blob/master/versions/3.0.0.md>
- [15] IETF RFC 8259: "The JavaScript Object Notation (JSON) Data Interchange Format".
- [16] IETF RFC 7807: "Problem Details for HTTP APIs".
- [17] IETF RFC 7396: "JSON Merge Patch".
- [18] IETF RFC 6749: "The OAuth 2.0 Authorization Framework".
- [19] 3GPP TS 29.510: "Network Function Repository Services; Stage 3".
- [20] 3GPP TS 23.122: "Non-Access-Stratum (NAS) functions related to Mobile Station in idle mode".

- [21] 3GPP TS 29.002: "Mobile Application Part (MAP) specification".
- [22] 3GPP TS 29.338: "Diameter based protocols to support Short Message Service (SMS) capable Mobile Management Entities (MMEs)"
- [23] ITU-T Recommendation E.164: "The international public telecommunication numbering plan".
- [24] 3GPP TS 29.509: "Authentication Server Services; Stage 3".
- [25] IETF RFC 7232: "Hypertext Transfer Protocol (HTTP/1.1): Conditional Requests".
- [26] IETF RFC 7234: "Hypertext Transfer Protocol (HTTP/1.1): Caching".
- [27] 3GPP TS 24.501: "Non-Access-Stratum (NAS) protocol for 5G System (5GS); Stage 3".
- [28] ETSI TS 102 225: "Smart Cards; Secured packet structure for UICC based applications".
- [29] IETF RFC 7542: "The Network Access Identifier".

3 Definitions and abbreviations

3.1 Definitions

For the purposes of the present document, the terms and definitions given in 3GPP TR 21.905 [1] and the following apply. A term defined in the present document takes precedence over the definition of the same term, if any, in 3GPP TR 21.905 [1].

3.2 Abbreviations

For the purposes of the present document, the abbreviations given in 3GPP TR 21.905 [1] and the following apply. An abbreviation defined in the present document takes precedence over the definition of the same abbreviation, if any, in 3GPP TR 21.905 [1].

5GC	5G Core Network
AMF	Access and Mobility Management Function
AUSF	Authentication Server Function
DNN	Data Network Name
FQDN	Fully Qualified Domain Name
GPSI	Generic Public Subscription Identifier
GUAMI	Globally Unique AMF Identifier
JSON	Javascript Object Notation
LADN	Local Area Data Network
MICO	Mobile Initiated Connection Only
NAI	Network Access Identifier
NAS	Non-Access Stratum
NEF	Network Exposure Function
NRF	Network Repository Function
NSSAI	Network Slice Selection Assistance Information
PEI	Permanent Equipment Identifier
QFI	QoS Flow Identifier
SBI	Service Based Interface
SMF	Session Management Function
SMSF	Short Message Service Function
SUCI	Subscription Concealed Identifier
SUPI	Subscription Permanent Identifier
UDM	Unified Data Management
UDR	Unified Data Repository

4 Overview

4.1 Introduction

Within the 5GC, the UDM offers services to the AMF, SMF, SMSF, NEF, GMLC and AUSF via the Nudm service based interface (see 3GPP TS 23.501 [2] and 3GPP TS 23.502 [3]).

Figure 4.1-1 provides the reference model (in service based interface representation and in reference point representation), with focus on the UDM.

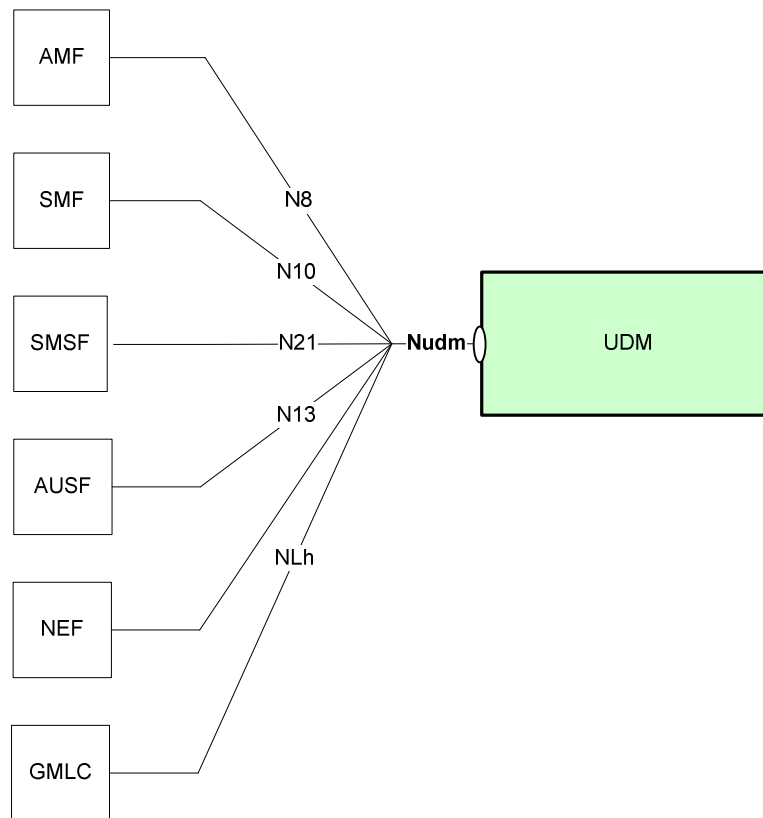

Figure 4.1-1: Reference model – UDM

The functionalities supported by the UDM are listed in subclause 6.2.7 of 3GPP TS 23.501 [2].

5 Services offered by the UDM

5.1 Introduction

The UDM offers the following services via the Nudm interface:

- Nudm_SubscriberDataManagement Service
- Nudm_UEContextManagement Service
- Nudm_UEAuthentication Service
- Nudm_EventExposure Service
- Nudm_ParameterProvision Service

All scenarios shown in the following subclauses assume that the UDM is stateful and stores information in local memory. However, the UDM may be stateless and stores information externally in the UDR. If so, the stateless UDM makes use of Nudr services as specified in 3GPP TS 29.504 [9] and 3GPP TS 29.505 [10] to retrieve required data from

the UDR and store them locally before processing an incoming request. Processing the incoming request may then include updating data in the UDR or subscribing to data change notifications at the UDR by consuming the appropriate Nudr services. After processing the incoming request, the UDM may delete the locally stored data. When data stored in UDR is then shared among the different UDM instances of the same group, as identified by UDM Group ID (see 3GPP TS 23.501 [2], clause 6.2.6), bulk subscriptions, as described in subclause 4.15.3.2.4 of 3GPP TS 23.502 [3], are not applicable, i.e. an NF consumer (e.g. NEF) only subscribes towards one of the UDM instances within the group. See Annex B.

5.2 Nudm_SubscriberDataManagement Service

5.2.1 Service Description

See 3GPP TS 23.501 [2] table 7.2.5-1.

5.2.2 Service Operations

5.2.2.1 Introduction

For the Nudm_SubscriberDataManagement service the following service operations are defined:

- Get
- Subscribe
- Unsubscribe
- Notification
- Info

The Nudm_SubscriberDataManagement Service is used by Consumer NFs (AMF, SMF, SMSF) to retrieve the UE's individual subscription data relevant to the consumer NF from the UDM by means of the Get service operation. If the consumer NF supports the feature "sharedData" (see subclause 6.1.8), the retrieved individual subscription data for the UE may contain shared data identifier identifying additional parts of subscription data shared by several UEs. If so, the Nudm_SubscriberDataManagement Service is also used by Consumer NFs to retrieve shared subscription data from the UDM by means of the Get service operation.

It is also used by Consumer NFs to subscribe to notifications of data change by means of the Subscribe service operation. If the consumer NF supports the feature "sharedData" (see subclause 6.1.8), the consumer NF may also subscribe to notifications of shared data change by means of the Subscribe service operation.

It is also used to unsubscribe from notifications of data changes by means of the Unsubscribe service operation. If the feature "sharedData" (see subclause 6.1.8) is supported, it may also be used to unsubscribe from notifications of shared data changes by means of the Unsubscribe service operation.

It is also used by the Consumer NFs (AMF, SMF, SMSF) that have previously subscribed, to get notified by means of the Notification service operation when UDM decides to modify the subscribed data. If the feature "sharedData" (see subclause 6.1.8) is supported by the consumer NF and the consumer NF has previously subscribed to notifications of shared data change, it is also used by the consumer NF to get notified by means of the Notification service operation when the UDM decides to modify the subscribed shared data.

It is also used by Consumer NFs to provide the information about the status of the subscription data management procedures.

5.2.2.2 Get

5.2.2.2.1 General

The following procedures using the Get service operation are supported:

- Slice Selection Subscription Data Retrieval
- Access and Mobility Subscription Data Retrieval
- SMF Selection Subscription Data Retrieval

- Session Management Subscription Data Retrieval
- SMS Subscription Data Retrieval
- SMS Management Subscription Data Retrieval
- UE Context in SMF Data Retrieval
- UE Context in SMSF Data Retrieval
- Retrieval Of Multiple Data Sets
- Identifier Translation
- Shared Subscription Data Retrieval

When the feature SharedData (see subclause 6.1.8) is supported and the retrieved UE-individual data (i.e. data other than Shared Subscription Data) contain SharedDataIds, the NF service consumer shall also retrieve the shared data identified by the received shared data Ids unless the identified shared data are already available at the NF service consumer. The order of sequence of sharedDataIds within UE-individual data is significant: Individual data take precedence over shared data; shared data "SharedDataX" identified by a sharedDataId X takes precedence over shared data "SharedDataY" identified by a sharedDataId Y if X appears before Y within the list of SharedDataIds in the UE-individual data.

5.2.2.2.2 Slice Selection Subscription Data Retrieval

Figure 5.2.2.2.2-1 shows a scenario where the NF service consumer (e.g. AMF) sends a request to the UDM to receive the UE's NSSAI (see also 3GPP TS 23.502 [3] figure 4.2.2.2.3-1 step 3). The request contains the UE's identity ($\{/supi\}$), the type of the requested information ($\{/nssai\}$) and query parameters (supported-features, plmn-id).

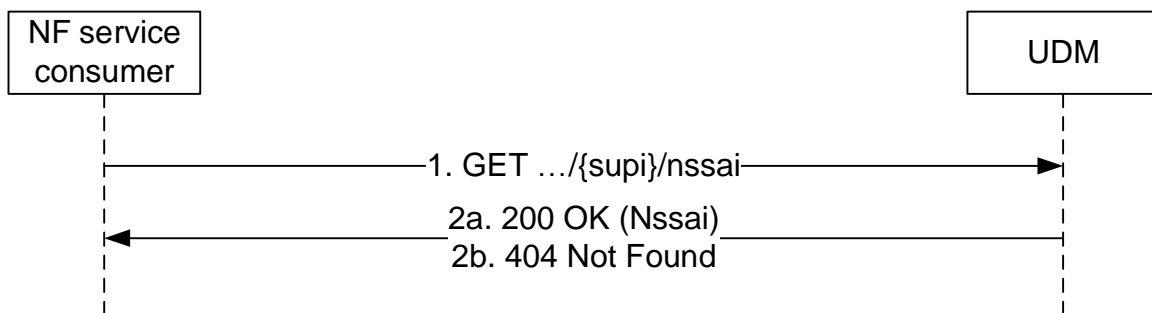

Figure 5.2.2.2.2-1: Requesting a UE's NSSAI

1. The NF service consumer (e.g. AMF) sends a GET request to the resource representing the UE's subscribed NSSAI, with query parameters indicating the supported-features and/or plmn-id.
- 2a. On success, the UDM responds with "200 OK" with the message body containing the UE's NSSAI as relevant for the requesting NF service consumer.
- 2b. If there is no valid subscription data for the UE, HTTP status code "404 Not Found" shall be returned including additional error information in the response body (in the "ProblemDetails" element).

On failure, the appropriate HTTP status code indicating the error shall be returned and appropriate additional error information should be returned in the GET response body.

5.2.2.2.3 Access and Mobility Subscription Data Retrieval

Figure 5.2.2.2.3-1 shows a scenario where the NF service consumer (e.g. AMF) sends a request to the UDM to receive the UE's Access and Mobility Subscription data (see also 3GPP TS 23.502 [3] figure 4.2.2.2.2-1 step 14). The request contains the UE's identity ($\{/supi\}$), the type of the requested information ($\{/am-data\}$) and query parameters (supported-features, plmn-id).

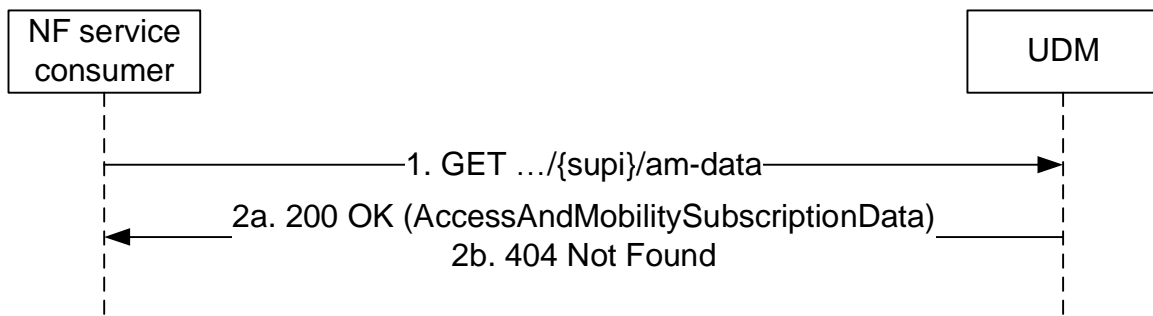

Figure 5.2.2.2.3-1: Requesting a UE's Access and Mobility Subscription Data

1. The NF service consumer (e.g. AMF) sends a GET request to the resource representing the UE's Access and Mobility Subscription Data, with query parameters indicating the supported-features and/or plmn-id.
- 2a. On Success, the UDM responds with "200 OK" with the message body containing the UE's Access and Mobility Subscription Data as relevant for the requesting NF service consumer.
- 2b. If there is no valid subscription data for the UE, HTTP status code "404 Not Found" shall be returned including additional error information in the response body (in the "ProblemDetails" element).

On failure, the appropriate HTTP status code indicating the error shall be returned and appropriate additional error information should be returned in the GET response body.

5.2.2.2.4 SMF Selection Subscription Data Retrieval

Figure 5.2.2.2.4-1 shows a scenario where the NF service consumer (e.g. AMF) sends a request to the UDM to receive the UE's SMF Selection Subscription data (see also 3GPP TS 23.502 [3] figure 4.2.2.2.2-1 step 14). The request contains the UE's identity ($\{/supi\}$), the type of the requested information ($\{/smf-select-data\}$) and query parameters (supported-features, plmn-id).

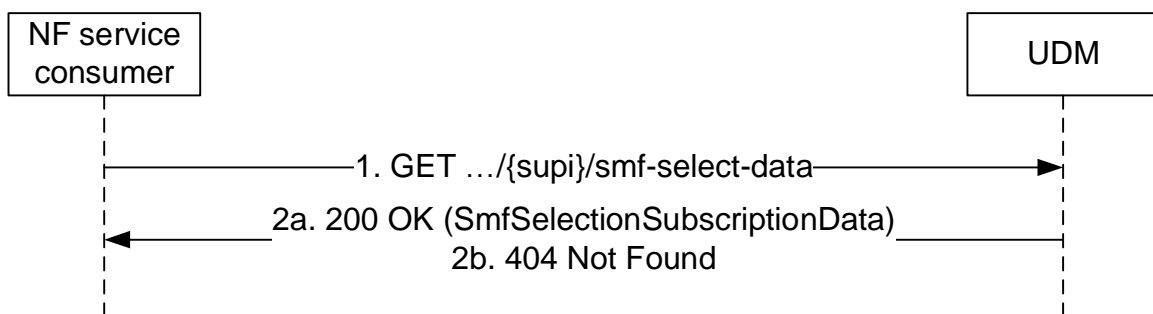

Figure 5.2.2.2.4-1: Requesting a UE's SMF Selection Subscription Data

1. The NF service consumer (e.g. AMF) sends a GET request to the resource representing the UE's SMF Selection Subscription Data, with query parameters indicating the supported-features and/or plmn-id.
- 2a. On success, the UDM responds with "200 OK" with the message body containing the UE's SMF Selection Subscription Data as relevant for the requesting NF service consumer.
- 2b. If there is no valid subscription data for the UE, HTTP status code "404 Not Found" shall be returned including additional error information in the response body (in the "ProblemDetails" element).

On failure, the appropriate HTTP status code indicating the error shall be returned and appropriate additional error information should be returned in the GET response body.

5.2.2.2.5 Session Management Subscription Data Retrieval

Figure 5.2.2.2.5-1 shows a scenario where the NF service consumer (e.g. SMF) sends a request to the UDM to receive the UE's session management subscription data (see also 3GPP TS 23.502 [3] figure 4.3.2.2.1-1 step 4a-4b). The

request contains the UE's identity ($\{/supi\}$), the type of the requested information ($\{/sm-data\}$), and query parameters (single-nssai, dnn, supported-features, plmn-id).

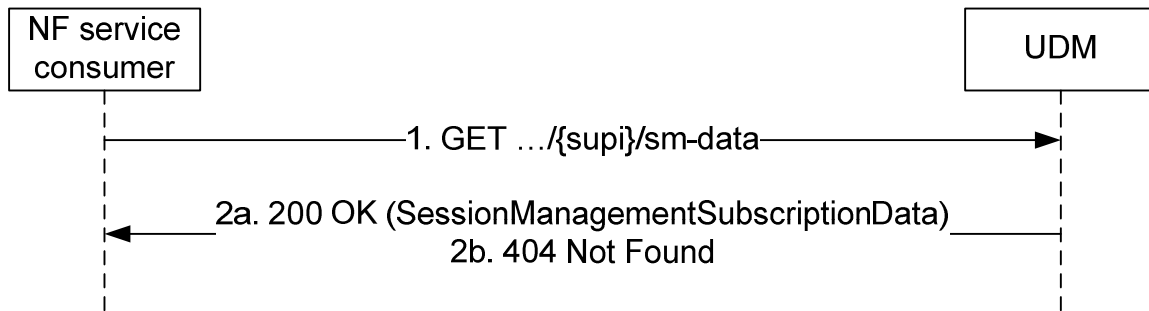

Figure 5.2.2.2.5-1: Requesting a UE's Session Management Subscription Data

1. The NF service consumer (e.g. SMF) sends a GET request to the resource representing the UE's session management subscription data, with query parameters indicating the selected network slice and/or the DNN and/or supported-features and/or plmn-id.
- 2a. On success, the UDM responds with "200 OK", the message body containing the UE's session management subscription data as relevant for the requesting NF service consumer.
- 2b. If there is no valid subscription data for the UE, or if the UE subscription data exists, but the requested session management subscription is not available (e.g. query parameter contains network slice and/or DNN that does not belong to the UE subscription), HTTP status code "404 Not Found" shall be returned including additional error information in the response body (in the "ProblemDetails" element).

On failure, the appropriate HTTP status code indicating the error shall be returned and appropriate additional error information should be returned in the GET response body.

5.2.2.2.6 SMS Subscription Data Retrieval

Figure 5.2.2.2.6-1 shows a scenario where the NF service consumer (e.g. AMF) sends a request to the UDM to receive the UE's SMS Subscription Data (see also 3GPP TS 23.502 [3], section 4.13.3.1). The request contains the UE's identity ($\{/supi\}$) and the type of the requested information ($\{/sms-data\}$).

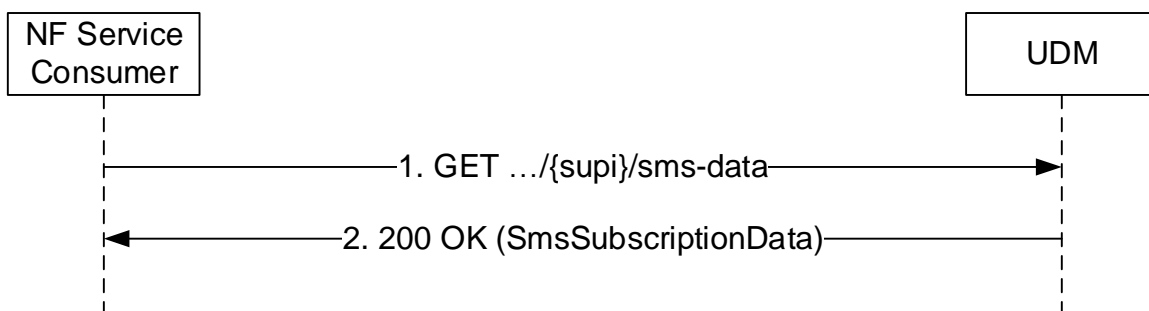

Figure 5.2.2.2.6-1: Requesting UE's SMS Subscription Data

1. The NF Service Consumer (e.g. AMF) sends a GET request to the resource representing the UE's SMS Subscription Data.
2. The UDM responds with "200 OK" with the message body containing the UE's SMS Subscription Data.

On failure, the appropriate HTTP status code indicating the error shall be returned and appropriate additional error information should be returned in the GET response body.

5.2.2.2.7 SMS Management Subscription Data Retrieval

Figure 5.2.2.2.7-1 shows a scenario where the NF service consumer (e.g. SMSF) sends a request to the UDM to receive the UE's SMS Management Subscription Data (see also 3GPP TS 23.502 [3], section 4.13.3.1). The request contains the UE's identity ($\{/supi\}$) and the type of the requested information ($\{/sms-mng-data\}$).

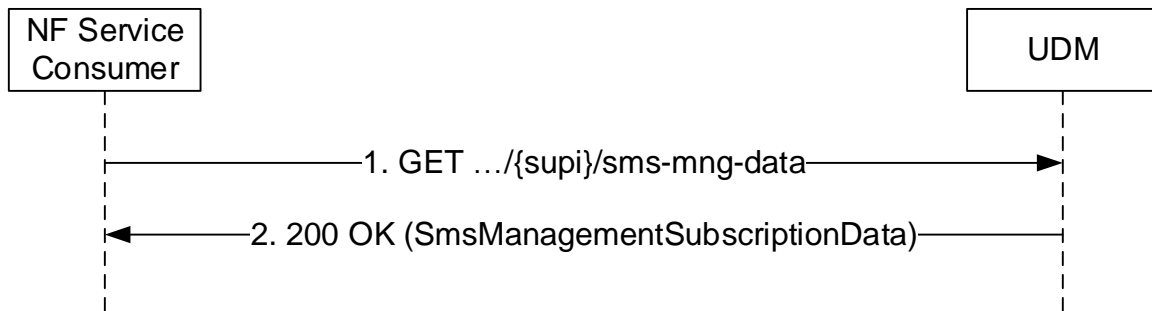

Figure 5.2.2.2.7-1: Requesting UE's SMS Management Subscription Data

1. The NF Service Consumer (e.g. SMSF) sends a GET request to the resource representing the UE's SMS Management Subscription Data.
2. The UDM responds with "200 OK" with the message body containing the UE's SMS Management Subscription Data.

On failure, the appropriate HTTP status code indicating the error shall be returned and appropriate additional error information should be returned in the GET response body.

5.2.2.2.8 UE Context In SMF Data Retrieval

Figure 5.2.2.2.8-1 shows a scenario where the NF service consumer (e.g. AMF) sends a request to the UDM to receive the UE's Context In SMF data (see also 3GPP TS 23.502 [3] figure 4.2.2.2.2-1 step 14). The request contains the UE's identity ($\{/supi\}$), the type of the requested information ($\{/ue-context-in-smf-data\}$) and query parameters (supported-features).

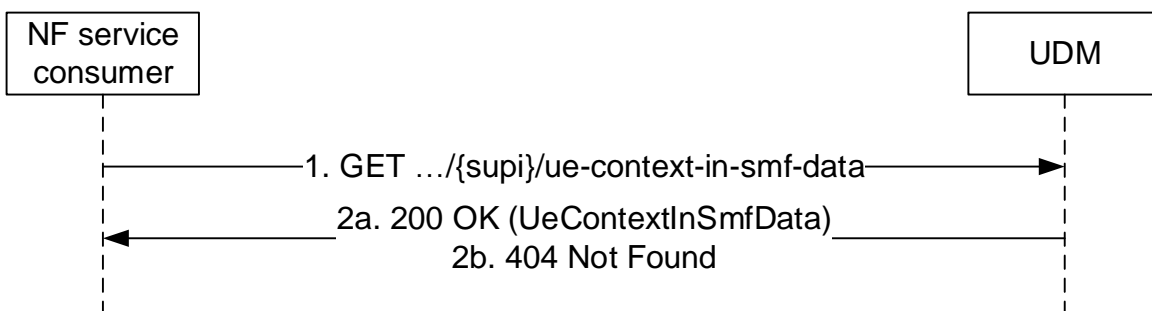

Figure 5.2.2.2.8-1: Requesting a UE's Context in SMF Data

1. The NF service consumer (e.g. AMF) shall send a GET request to the resource representing the UE's Context In SMF Data, with query parameters indicating the supported-features.
- 2a. On Success, the UDM shall respond with "200 OK" with the message body containing the UE's Context In SMF Data as relevant for the requesting NF service consumer.
- 2b. If there is no valid subscription data for the UE, HTTP status code "404 Not Found" shall be returned including additional error information in the response body (in the "ProblemDetails" element).

On failure, the appropriate HTTP status code indicating the error shall be returned and appropriate additional error information should be returned in the GET response body.

5.2.2.2.9 Retrieval Of Multiple Data Sets

Figure 5.2.2.2.9-1 shows a scenario where the NF service consumer (e.g. AMF) sends a request to the UDM to receive multiple data sets. In this example scenario the UE's Access and Mobility Subscription data and the UE's SMF Selection Subscription data are retrieved with a single request; see subclause 6.1.3.11.3.1 for other data sets that can be retrieved with a single request. The request contains the UE's identity ($\{\text{supi}\}$) and query parameters identifying the requested data sets (in this example: $\text{?dataset-names=AM, SMF_SEL}$).

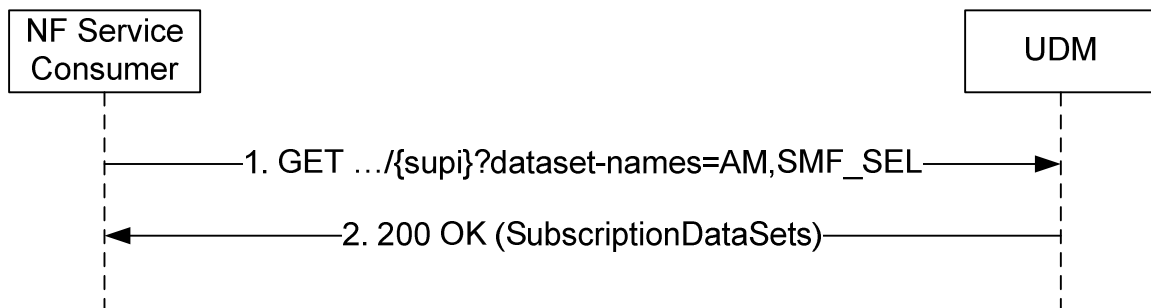

Figure 5.2.2.2.9-1: Retrieval of Multiple Data Sets

1. The NF Service Consumer (e.g. AMF) sends a GET request to the resource representing the supi . Query parameters indicate the requested data sets.
2. The UDM responds with "200 OK" with the message body containing the requested data sets.

On failure, the appropriate HTTP status code indicating the error shall be returned and appropriate additional error information should be returned in the GET response body.

5.2.2.2.10 Identifier Translation

Figure 5.2.2.2.10-1 shows a scenario where the NF service consumer (e.g. NEF) sends a request to the UDM to receive the SUPI that corresponds to the provided GPSI (see also 3GPP TS 23.502 [3], section 4.13.2.2). The request contains the UE's identity ($\{\text{gpsi}\}$) and the type of the requested information ($\text{/id-translation-result}$).

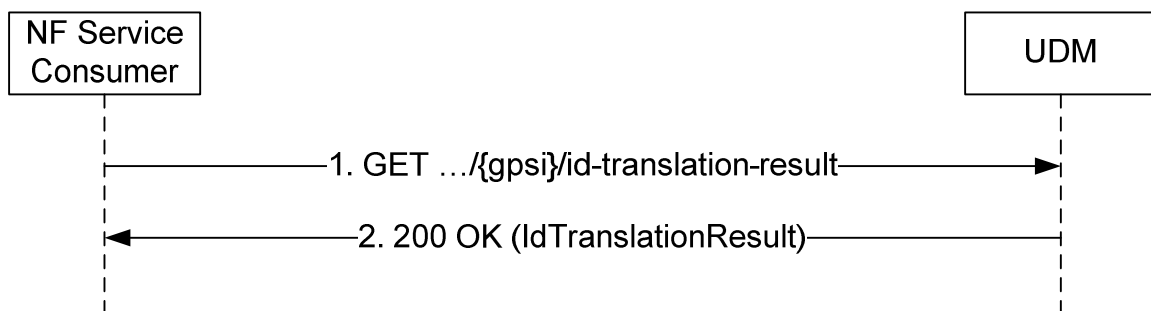

Figure 5.2.2.2.10-1: Identifier Translation

1. The NF Service Consumer (e.g. NEF) shall send a GET request to the resource representing the $\text{IdTranslationResult}$.
2. The UDM shall respond with "200 OK" with the message body containing the UE's SUPI.

On failure, the appropriate HTTP status code indicating the error shall be returned and appropriate additional error information should be returned in the GET response body.

5.2.2.2.11 Shared Subscription Data Retrieval

Figure 5.2.2.2.11-1 shows a scenario where the NF service consumer (e.g. AMF) sends a request to the UDM to receive the shared subscription data. The request contains the type of the requested information (/shared-data) and query parameters (supportedFeatures, shared-data-id).

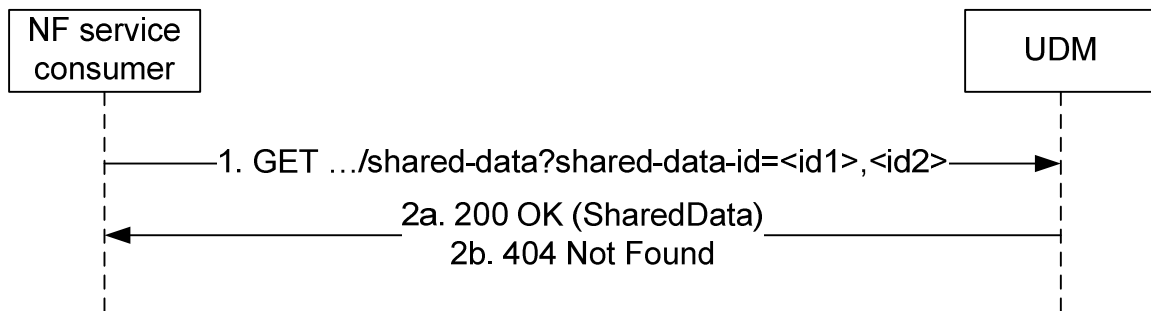

Figure 5.2.2.2.11-1: Requesting shared data

1. The NF service consumer (e.g. AMF) sends a GET request to the resource representing the SharedData, with query parameters indicating the supportedFeatures and shared-data-id.
- 2a. On success, the UDM responds with "200 OK" with the message body containing the SharedData.
- 2b. If there is no valid shared data for one or more of the shared-data-ids, HTTP status code "404 Not Found" shall be returned including additional error information in the response body (in the "ProblemDetails" element).

On failure, the appropriate HTTP status code indicating the error shall be returned and appropriate additional error information should be returned in the GET response body.

5.2.2.2.12 UE Context In SMSF Data Retrieval

Figure 5.2.2.2.12-1 shows a scenario where the NF service consumer (e.g. AMF) sends a request to the UDM to receive the UE's Context In SMSF data. The request contains the UE's identity (/supi), the type of the requested information (/ue-context-in-smsf-data) and query parameters (supported-features).

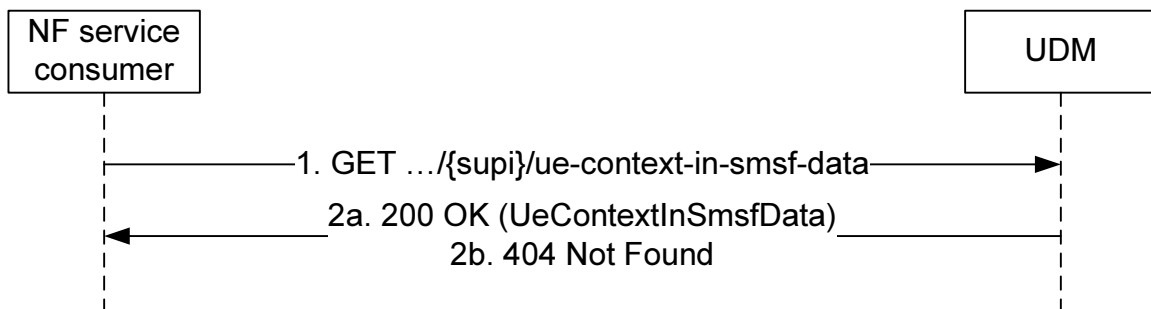

Figure 5.2.2.2.12-1: Requesting a UE's Context in SMSF Data

1. The NF service consumer (e.g. AMF) shall send a GET request to the resource representing the UE's Context In SMSF Data, with query parameters indicating the supported-features.
- 2a. On Success, the UDM shall respond with "200 OK" with the message body containing the UE's Context In SMSF Data as relevant for the requesting NF service consumer.
- 2b. If there is no valid subscription data for the UE, HTTP status code "404 Not Found" shall be returned including additional error information in the response body (in the "ProblemDetails" element).

On failure, the appropriate HTTP status code indicating the error shall be returned and appropriate additional error information should be returned in the GET response body.

5.2.2.3 Subscribe

5.2.2.3.1 General

The following procedures using the Subscribe service operation are supported:

- Subscription to notification of data change (for UE individual data)
- Subscription to notification of shared data change

5.2.2.3.2 Subscription to notifications of data change

Figure 5.2.2.3.2-1 shows a scenario where the NF service consumer sends a request to the UDM to subscribe to notifications of data change (see also 3GPP TS 23.502 [3] figure 4.2.2.2.2-1 step 14). The request contains a callback URI and the URI of the monitored resource.

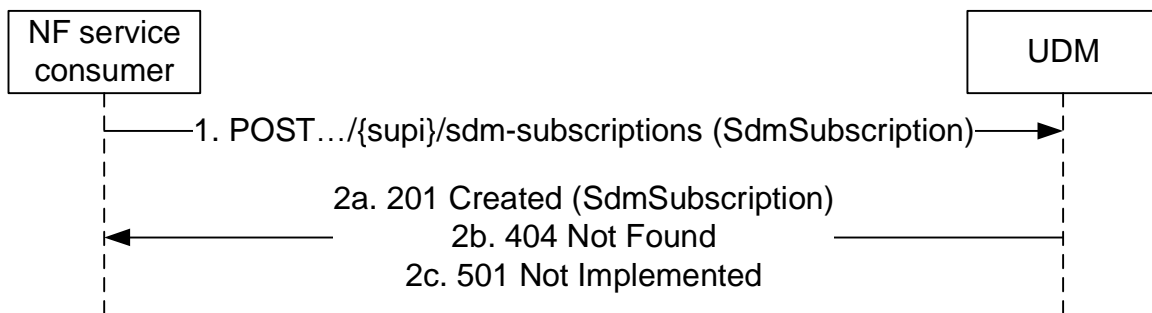

Figure 5.2.2.3.2-1: NF service consumer subscribes to notifications

1. The NF service consumer sends a POST request to the parent resource (collection of subscriptions) (.../{supi}/sdm-subscriptions), to create a subscription as present in message body.
- 2a. On success, the UDM responds with "201 Created" with the message body containing a representation of the created subscription. The Location HTTP header shall contain the URI of the created subscription.
- 2b. If there is no valid subscription data for the UE, HTTP status code "404 Not Found" shall be returned including additional error information in the response body (in the "ProblemDetails" element).
- 2c. If the UE subscription data exist, but the requested subscription to data change notification cannot be created (e.g. due to an invalid/unsupported data reference to be monitored, contained in the SdmSubscription parameter), HTTP status code "501 Not Implemented" shall be returned including additional error information in the response body (in the "ProblemDetails" element).

On failure, the appropriate HTTP status code indicating the error shall be returned and appropriate additional error information should be returned in the POST response body.

5.2.2.3.3 Subscription to notifications of shared data change

Figure 5.2.2.3.3-1 shows a scenario where the NF service consumer sends a request to the UDM to subscribe to notifications of shared data change. The request contains a callback URI and the URI of the monitored resource.

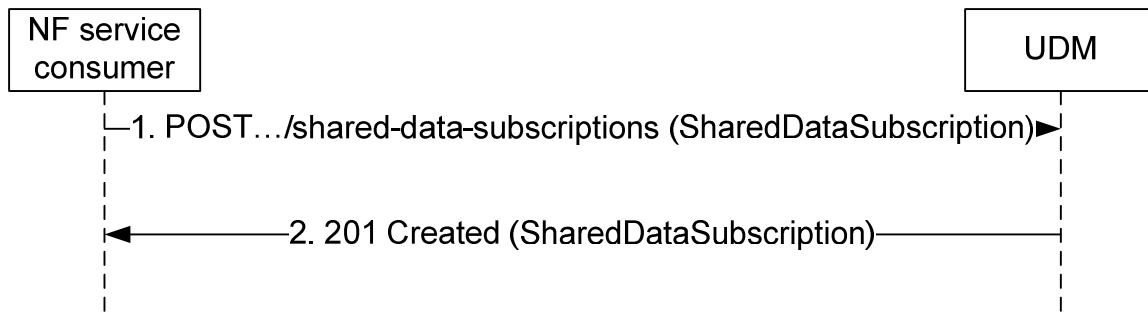

Figure 5.2.2.3.3-1: NF service consumer subscribes to notifications of shared data change

1. The NF service consumer sends a POST request to the parent resource (collection of subscriptions) (.../shared-data-subscriptions), to create a subscription as present in message body.
2. On success, the UDM responds with "201 Created" with the message body containing a representation of the created subscription. The Location HTTP header shall contain the URI of the created subscription.

On failure, the appropriate HTTP status code indicating the error shall be returned and appropriate additional error information should be returned in the POST response body.

5.2.2.4 Unsubscribe

5.2.2.4.1 General

The following procedures using the Unsubscribe service operation are supported:

- Unsubscribe to notification of data change (for UE individual data)
- Unsubscribe to notifications of shared data change

5.2.2.4.2 Unsubscribe to notifications of data change

Figure 5.2.2.4.2-1 shows a scenario where the NF service consumer sends a request to the UDM to unsubscribe from notifications of data changes (see also 3GPP TS 23.502 [3] figure 4.2.2.2.2-1 step 14). The request contains the URI previously received in the Location HTTP header of the response to the subscription.

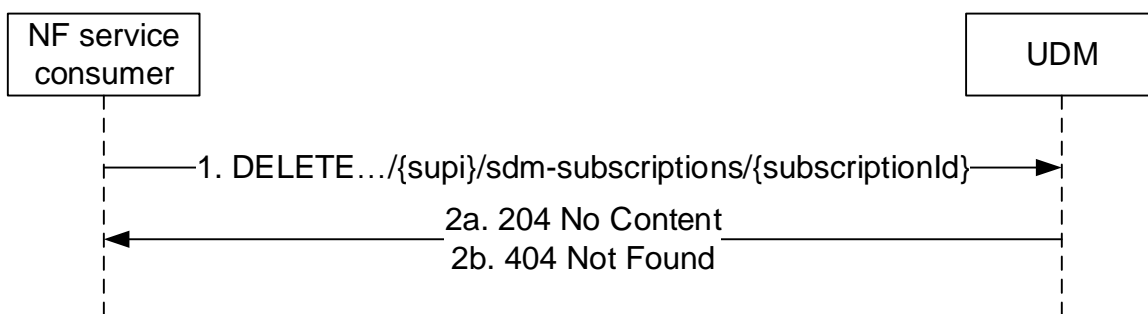

Figure 5.2.2.4.2-1: NF service consumer unsubscribes to notifications

1. The NF service consumer sends a DELETE request to the resource identified by the URI previously received during subscription creation.
- 2a. On success, the UDM responds with "204 No Content".
- 2b. If there is no valid subscription available (e.g. due to an unknown subscriptionId value), HTTP status code "404 Not Found" should be returned including additional error information in the response body (in the "ProblemDetails" element).

On failure, the appropriate HTTP status code indicating the error shall be returned and appropriate additional error information should be returned in the DELETE response body.

5.2.2.4.3 Unsubscribe to notifications of data change

Figure 5.2.2.4.3-1 shows a scenario where the NF service consumer sends a request to the UDM to unsubscribe from notifications of shared data changes. The request contains the URI previously received in the Location HTTP header of the response to the subscription.

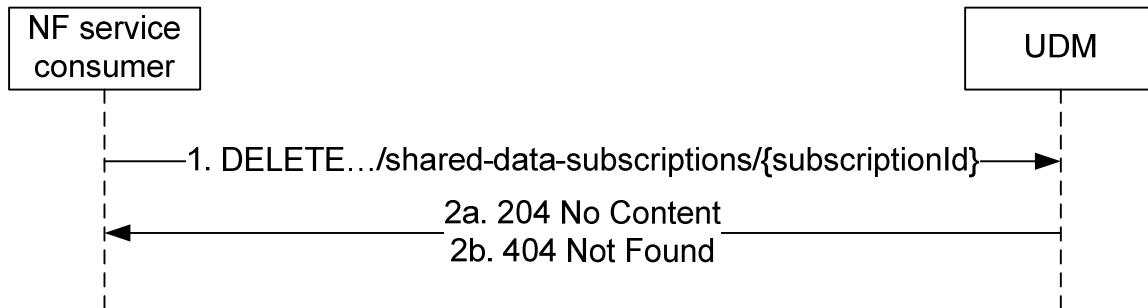

Figure 5.2.2.4.3-1: NF service consumer unsubscribes to notifications for shared data

1. The NF service consumer sends a DELETE request to the resource identified by the URI previously received during subscription creation.
- 2a. On success, the UDM responds with "204 No Content".
- 2b. If there is no valid subscription available (e.g. due to an unknown subscriptionId value), HTTP status code "404 Not Found" should be returned including additional error information in the response body (in the "ProblemDetails" element).

On failure, the appropriate HTTP status code indicating the error shall be returned and appropriate additional error information should be returned in the DELETE response body.

5.2.2.5 Notification

5.2.2.5.1 General

The following procedures using the Notification service operation are supported:

- Data change notification to NF

5.2.2.5.2 Data Change Notification To NF

Figure 5.2.2.5.2-1 shows a scenario where the UDM notifies the NF service consumer (that has subscribed to receive such notification) about subscription data change (see also 3GPP TS 23.502 [3] subclause 4.5.2) or shared data change. The request contains the callbackReference URI as previously received in the SdmSubscription (see subclause 6.1.6.2.3).

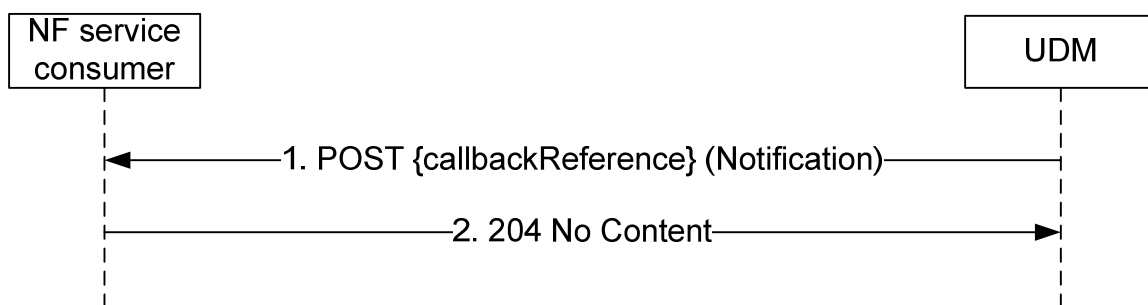

Figure 5.2.2.5.2-1: Subscription Data Change Notification

1. The UDM sends a POST request to the callbackReference as provided by the NF service consumer during the subscription.
2. The NF service consumer responds with "204 No Content".

On failure, the appropriate HTTP status code indicating the error shall be returned and appropriate additional error information should be returned in the POST response body.

5.2.2.6 Info

5.2.2.6.1 General

The following procedures using the Info service operation are supported:

- Providing acknowledgement from the UE to UDM about successful delivery of Steering of Roaming information via the AMF as defined in 3GPP TS 23.122 [20]

5.2.2.6.2 Providing acknowledgement of Steering of Roaming

Figure 5.2.2.6.2-1 shows a scenario where the NF service consumer (e.g. AMF) sends the UE acknowledgement to the UDM (see also 3GPP TS 23.122 [20] Annex C). The request contains the UE's identity ($\{supi\}$), the type of the acknowledgement information ($\{am-data/sor-ack\}$), and the SOR-MAC-Iue.

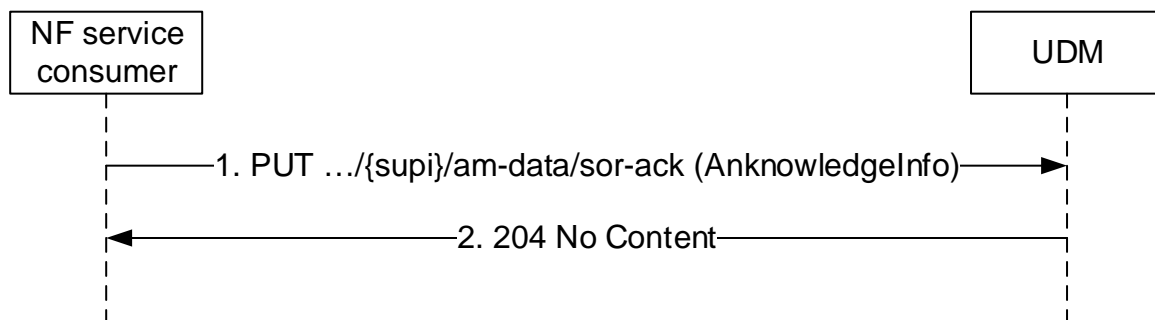

Figure 5.2.2.6.2-1: Providing acknowledgement of Steering of Roaming

1. The NF service consumer (e.g. AMF) sends a PUT request to the resource representing the UE's Access and Mobility Subscription Data, with the AcknowledgeInfo (SOR-MAC-Iue) received from the UE.
2. The UDM responds with "204 No Content".

On failure, the appropriate HTTP status code indicating the error shall be returned and appropriate additional error information should be returned in the PUT response body.

5.3 Nudm_UEContextManagement Service

5.3.1 Service Description

See 3GPP TS 23.501 [2] table 7.2.5-1.

5.3.2 Service Operations

5.3.2.1 Introduction

For the Nudm_UEContextManagement service the following service operations are defined:

- Registration
- DeregistrationNotification

- Deregistration
- Get
- Update
- P-CSCF-RestorationNotification

The Nudm_UEContextManagement Service is used by Consumer NFs (AMF, SMS, SMSF) to register at the UDM by means of the Registration service operation.

It is also used by the registered Consumer NFs (AMF) to get notified by means of the DeregistrationNotification service operation when UDM decides to deregister the registered consumer NF.

It is also used by the registered Consumer NFs (AMF, SMF, SMSF) to deregister from the UDM by means of the Deregistration service operation.

It is also used by consumer NFs (NEF) to retrieve registration information from the UDM by means of the Get service operation.

It is also used by the registered Consumer NFs (AMF, SMF) to update registration information stored at the UDM by means of the Update service operation.

It is also used by the registered Consumer NFs (AMF, SMF) to get notified by means of the P-CSCF-RestorationNotification service operation when UDM detects the need for P-CSCF restoration.

5.3.2.2 Registration

5.3.2.2.1 General

The Registration service operation is invoked by a NF that has been selected to provide service to the UE to store related UE Context Management information in UDM.

NF Consumers are AMF for access and mobility management service, SMF for session management services and SMSF providing SMS services.

As part of this registration procedure, the UDM authorizes or rejects the subscriber to use the service provided by the registered NF, based on subscription data (e.g. roaming restrictions).

The following procedures using the Registration service operation are supported:

- AMF registration for 3GPP access
- AMF registration for non-3GPP access
- SMF registration
- SMSF registration for 3GPP access
- SMSF registration for non-3GPP access

5.3.2.2.2 AMF registration for 3GPP access

Figure 5.3.2.2.2-1 shows a scenario where the AMF sends a request to the UDM to update the AMF registration information for 3GPP access (see also 3GPP TS 23.502 [3] figure 4.2.2.2.2-1 step 14). The request contains the UE's identity ($\{ueId\}$) which shall be a SUPI and the AMF Registration Information for 3GPP access.

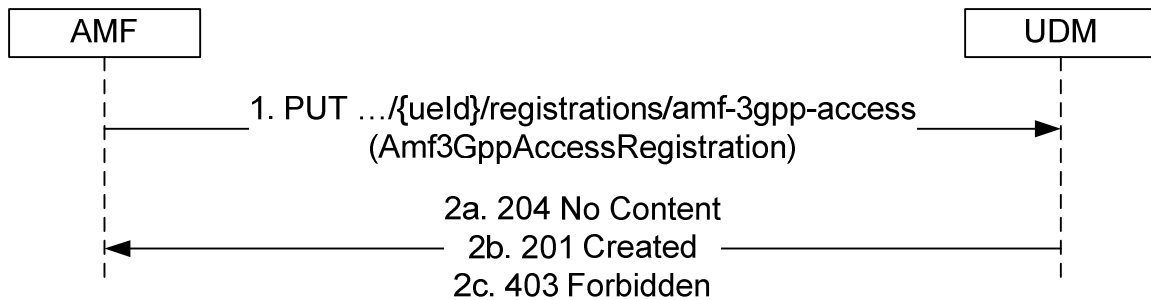

Figure 5.3.2.2.2-1: AMF registering for 3GPP access

1. The AMF sends a PUT request to the resource representing the UE's AMF registration for 3GPP access to update or create AMF registration information.
- 2a. On success, and if another AMF is registered for 3GPP access, the UDM updates the Amf3GppAccessRegistration resource by replacing it with the received resource information, and responds with "204 No Content".

UDM shall invoke the Deregistration Notification service operation towards the old AMF using the callback URI provided by the old AMF.
- 2b. If the resource does not exist (there is no previous AMF information stored in UDM for that user), UDM stores the received AMF registration data for 3GPP access and responds with HTTP Status Code "201 created". A response body may be included to convey additional information to the NF consumer (e.g., features supported by UDM).
- 2c. If the operation cannot be authorized due to e.g UE does not have required subscription data, access barring or roaming restrictions, HTTP status code "403 Forbidden" should be returned including additional error information in the response body (in "ProblemDetails" element).

On failure, the appropriate HTTP status code indicating the error shall be returned and appropriate additional error information should be returned in the PUT response body.

5.3.2.2.3 AMF registration for non 3GPP access

Figure 5.3.2.2.3-1 shows a scenario where the AMF sends a request to the UDM to update the AMF registration information for non 3GPP access (see also 3GPP TS 23.502 [3] figure 4.2.2.2.2-1 step 14). The request contains the UE's identity ($\{ueId\}$) which shall be a SUPI and the AMF Registration Information for non 3GPP access.

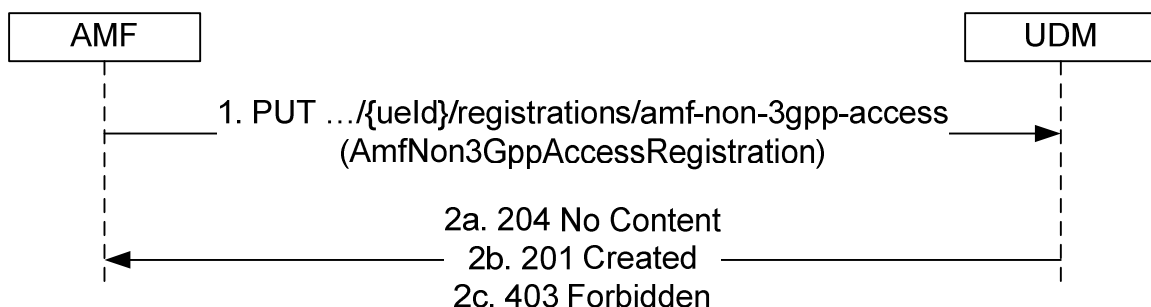

Figure 5.3.2.2.3-1: AMF registering for non 3GPP access

1. The AMF sends a PUT request to the resource representing the UE's AMF registration for non 3GPP access to update or create AMF registration information.
- 2a. On success, and if another AMF is registered for non-3GPP access, the UDM updates the AmfNon3GppAccessRegistration resource by replacing it with the received resource information, and responds with "204 No Content".

UDM shall invoke the Deregistration Notification service operation towards the old AMF using the callback URI provided by the old AMF.

- 2b. If the resource does not exist (there is no previous AMF information stored in UDM for that user), UDM stores the received AMF registration data for non-3GPP access and responds with HTTP Status Code "201 created". A response body may be included to convey additional information to the NF consumer (e.g., features supported by UDM).
- 2c. If the operation cannot be authorized due to e.g UE does not have required subscription data, access barring or roaming restrictions, HTTP status code "403 Forbidden" should be returned including additional error information in the response body (in the "ProblemDetails" element).

On failure, the appropriate HTTP status code indicating the error shall be returned and appropriate additional error information should be returned in the PUT response body.

5.3.2.2.4 SMF registration

Figure 5.3.2.2.4-1 shows a scenario where an SMF sends a request to the UDM to create a new registration (see also 3GPP TS 23.502 [3] figure 4.3.2.2.1-1 step 4). The request contains the UE's identity ($\{ueId\}$) which shall be a SUPI and the SMF Registration Information.

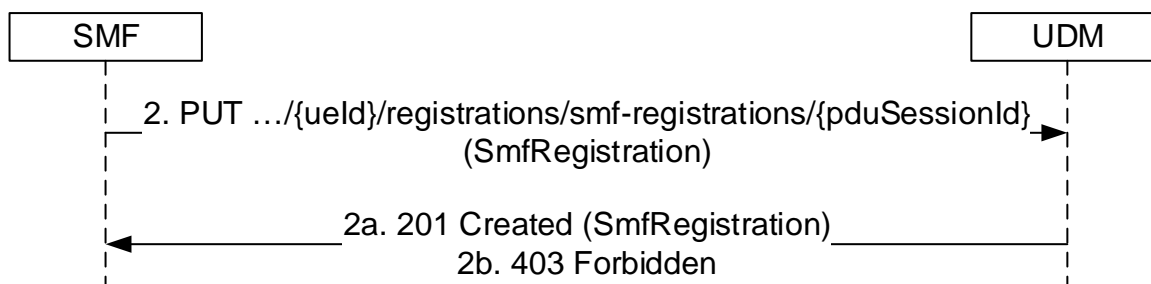

Figure 5.3.2.2.4-1: SMF registration

1. The SMF sends a PUT request to the resource $\dots\{ueId\}/registrations/smf-registrations/\{pduSessionId\}$, to create an SMF Registration as present in the message body.
- 2a. The UDM responds with "201 Created" with the message body containing a representation of the created SMF registration.
- 2b. If the operation cannot be authorized due to e.g UE does not have required subscription data, access barring or roaming restrictions, HTTP status code "403 Forbidden" should be returned including additional error information in the response body (in "ProblemDetails" element).

On failure, the appropriate HTTP status code indicating the error shall be returned and appropriate additional error information should be returned in the PUT response body.

5.3.2.2.5 SMSF Registration for 3GPP Access

Figure 5.3.2.2.5-1 shows a scenario where the SMSF sends a request to the UDM to create or update the SMSF registration information for 3GPP access (see also 3GPP TS 23.502 [3], section 4.13.3.1). The request contains the UE's identity ($\{ueId\}$) which shall be a SUPI and the SMSF Registration Information for SMS service.

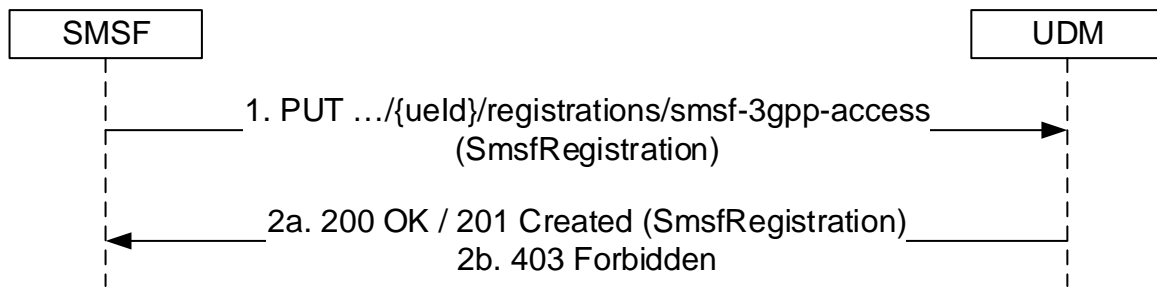

Figure 5.3.2.2.5-1: SMSF registering for 3GPP Access

1. The SMSF sends a PUT request to the resource representing the UE's SMSF registration for 3GPP Access to update or create SMSF registration information.
- 2a. If successful, the UDM responds with "200 OK", or "201 Created" with the message body containing the representation of the SmsfRegistration.
- 2b. If the operation cannot be authorized due to e.g UE does not have required subscription data, access barring or roaming restrictions, HTTP status code "403 Forbidden" should be returned including additional error information in the response body (in "ProblemDetails" element).

On failure, the appropriate HTTP status code indicating the error shall be returned and appropriate additional error information should be returned in the PUT response body.

5.3.2.2.6 SMSF Registration for Non 3GPP Access

Figure 5.3.2.2.6-1 shows a scenario where the SMSF sends a request to the UDM to create or update the SMSF registration information for non 3GPP access (see also 3GPP TS 23.502 [3], section 4.13.3.1). The request contains the UE's identity ($\{ueId\}$) which shall be a SUPI and the SMSF Registration Information for SMS service.

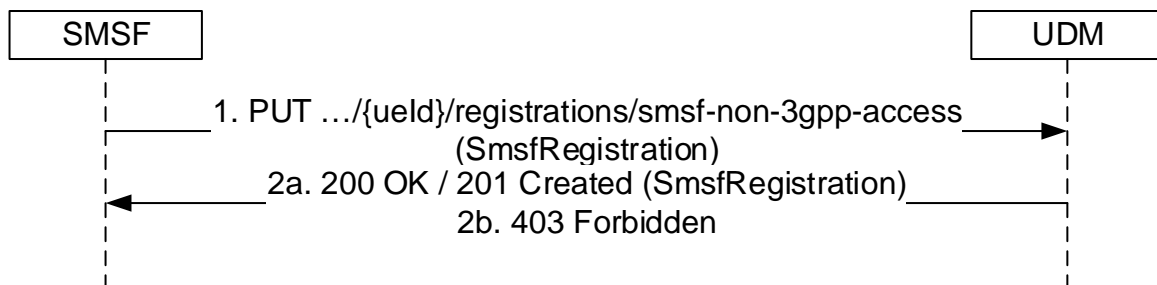

Figure 5.3.2.2.6-1: SMSF registering for Non 3GPP Access

1. The SMSF sends a PUT request to the resource representing the UE's SMSF registration for Non 3GPP Access to update or create SMSF registration information.
- 2a. If successful, the UDM responds with "200 OK", or "201 Created" with the message body containing the representation of the SmsfRegistration.
- 2b. If the operation cannot be authorized due to e.g UE does not have required subscription data, access barring or roaming restrictions, HTTP status code "403 Forbidden" should be returned including additional error information in the response body (in "ProblemDetails" element).

On failure, the appropriate HTTP status code indicating the error shall be returned and appropriate additional error information should be returned in the PUT response body.

5.3.2.3 DeregistrationNotification

5.3.2.3.1 General

The following procedure using the DeregistrationNotification service operation is supported:

- UDM initiated NF Deregistration

5.3.2.3.2 UDM initiated NF Deregistration

Figure 5.3.2.3.2-1 shows a scenario where the UDM notifies the registered NF about its deregistration (see also 3GPP TS 23.502 [3] figure 4.2.2.2-1 step 14). The request contains the callback URI for deregistration notification as received by the UDM during registration, and Deregistration Data.

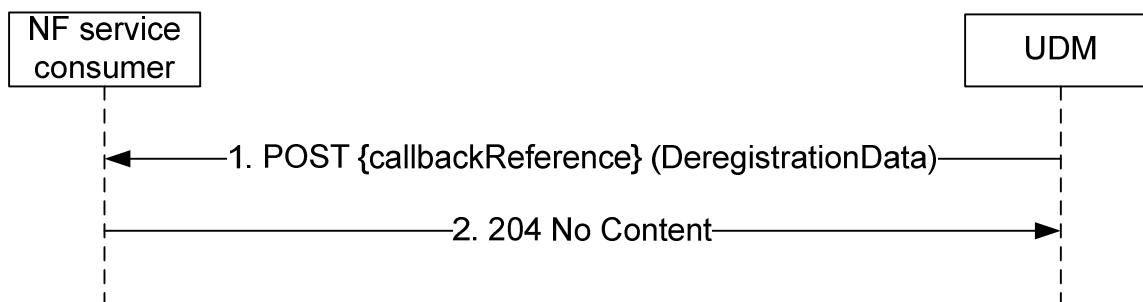

Figure 5.3.2.3.2-1: UDM initiated NF Deregistration

1. The UDM sends a POST request to the callbackReference as provided by the NF service consumer during the registration.
2. The NF service consumer responds with "204 No Content".

On failure, the appropriate HTTP status code indicating the error shall be returned and appropriate additional error information should be returned in the POST response body.

5.3.2.4 Deregistration

5.3.2.4.1 General

The following procedures using the Deregistration service operation are supported:

- AMF deregistration for 3GPP access
- AMF deregistration for non-3GPP access
- SMF deregistration
- SMSF deregistration for 3GPP access
- SMSF deregistration for non-3GPP access

5.3.2.4.2 AMF deregistration for 3GPP access

Figure 5.3.2.4.2-1 shows a scenario where the AMF sends a request to the UDM to deregister (purge) from the UDM for 3GPP access (see also 3GPP TS 23.502 [3] figure 4.5.3.1-1 step 3). The request contains the UE's identity (`{ueId}`) which shall be a SUPI and an instruction to set the `purgeFlag` within the `Amf3GppAccessRegistration` resource.

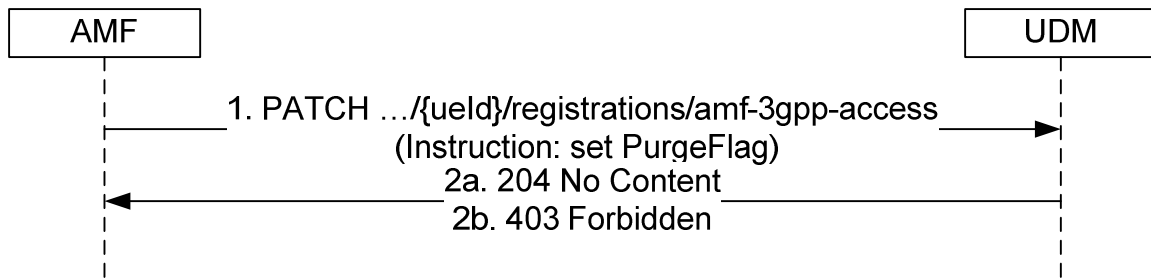

Figure 5.3.2.4.2-1: AMF deregistering for 3GPP access

1. The AMF sends a PATCH request to the resource representing the UE's AMF registration for 3GPP access.
- 2a. The UDM shall check whether the received GUAMI matches the stored GUAMI. If so, the UDM shall set the PurgeFlag. The UDM responds with "204 No Content".
- 2b. Otherwise the UDM responds with "403 Forbidden".

On failure, the appropriate HTTP status code indicating the error shall be returned and appropriate additional error information should be returned in the PATCH response body.

5.3.2.4.3 AMF deregistration for non-3GPP access

Figure 5.3.2.4.3-1 shows a scenario where the AMF sends a request to the UDM to deregister (purge) from the UDM for non-3GPP access (see also 3GPP TS 23.502 [3] figure 4.5.3.1-1 step 3). The request contains the UE's identity ($\{ueId\}$) which shall be a SUPI and an instruction to set the purgeFlag within the AmfNon3GppAccessRegistration resource.

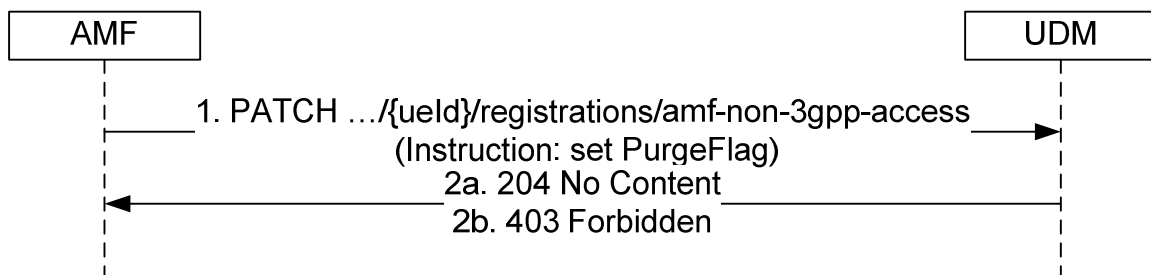

Figure 5.3.2.4.3-1: AMF deregistering for non-3GPP access

1. The AMF sends a PATCH request to the resource representing the UE's AMF registration for non-3GPP access.
- 2a. The UDM shall check whether the received GUAMI matches the stored GUAMI. If so, the UDM shall set the PurgeFlag. The UDM responds with "204 No Content".
- 2b. Otherwise the UDM responds with "403 Forbidden".

On failure, the appropriate HTTP status code indicating the error shall be returned and appropriate additional error information should be returned in the PATCH response body.

5.3.2.4.4 SMF deregistration

Figure 5.3.2.4.4-1 shows a scenario where the SMF sends a request to the UDM to deregister an individual SMF registration (see also 3GPP TS 23.502 [3] figure 4.3.2.2-1 step 20). The request contains the UE's identity ($\{ueId\}$) which shall be a SUPI and the PDU Session ID ($\{pduSessionId\}$).

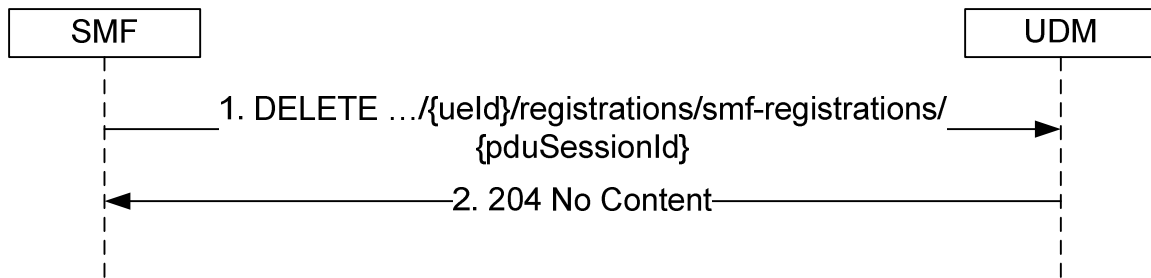

Figure 5.3.2.4.4-1: SMF deregistration

1. The SMF sends a DELETE request to the resource representing the individual SMF registration that is to be deregistered.
2. The UDM responds with "204 No Content".

On failure, the appropriate HTTP status code indicating the error shall be returned and appropriate additional error information should be returned in the DELETE response body.

5.3.2.4.5 SMSF Deregistration for 3GPP Access

Figure 5.3.2.4.5-1 shows a scenario where the SMSF sends a request to the UDM to delete the SMSF registration information for 3GPP access (see also 3GPP TS 23.502 [3], section 4.13.3.2). The request contains the UE's identity ($\{ueId\}$) which shall be a SUPI.

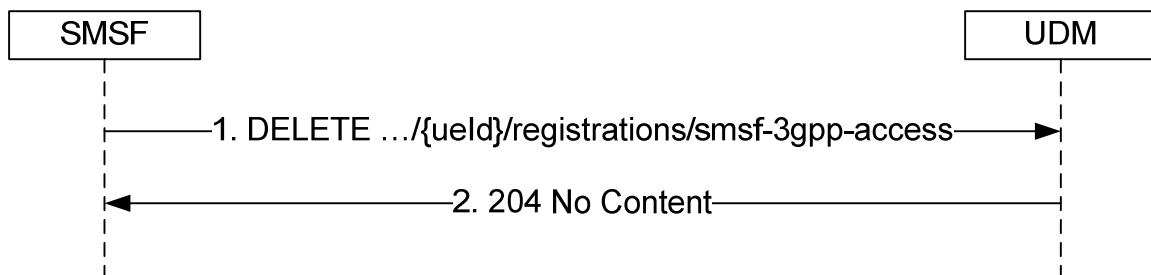

Figure 5.3.2.4.5-1: SMSF Deregistering for 3GPP Access

1. The SMSF sends a DELETE request to the resource representing the UE's SMSF registration for 3GPP access.
2. If successful, the UDM responds with "204 No Content".

On failure, the appropriate HTTP status code indicating the error shall be returned and appropriate additional error information should be returned in the DELETE response body.

5.3.2.4.6 SMSF Deregistration for Non 3GPP Access

Figure 5.3.2.4.6-1 shows a scenario where the SMSF sends a request to the UDM to delete the SMSF registration information for non 3GPP access (see also 3GPP TS 23.502 [3], section 4.13.3.2). The request contains the UE's identity ($\{ueId\}$) which shall be a SUPI.

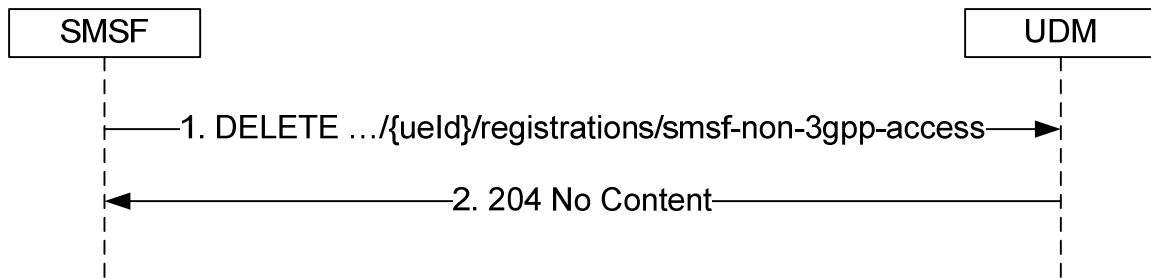

Figure 5.3.2.4.6-1: SMSF Deregistering for Non 3GPP Access

1. The SMSF sends a DELETE request to the resource representing the UE's SMSF registration for non 3GPP access.
2. If successful, the UDM responds with "204 No Content".

On failure, the appropriate HTTP status code indicating the error shall be returned and appropriate additional error information should be returned in the DELETE response body.

5.3.2.5 Get

5.3.2.5.1 General

The following procedures using the Get service operation are supported:

- Amf3GppAccessRegistration Information Retrieval
- AmfNon3GppAccessRegistration Information Retrieval
- SmfRegistrations Information Retrieval
- SmsfRegistration Information Retrieval for 3GPP Access
- SmsfRegistration Information Retrieval for Non-3GPP Access

5.3.2.5.2 Amf3GppAccessRegistration Information Retrieval

Figure 5.3.2.5.2-1 shows a scenario where the NF service consumer (e.g. NEF) sends a request to the UDM to retrieve the UE's Amf3GppAccessRegistration Information. The request contains the UE's identity ($\{ueId\}$) which shall be a GPSI, the type of the requested information ($/registration/amf-3gpp-access$) and query parameters (supported-features).

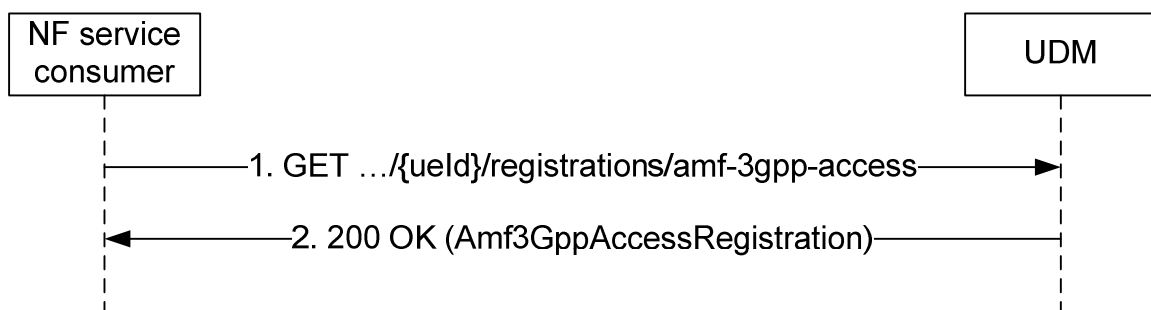

Figure 5.3.2.5.2-1: Requesting a UE's AMF Registration Information for 3GPP Access

1. The NF service consumer (e.g. NEF) sends a GET request to the resource representing the UE's AMF registration information for 3GPP access, with query parameters indicating the supported-features.
2. The UDM responds with "200 OK" with the message body containing the UE's Amf3GppAccessRegistration.

On failure, the appropriate HTTP status code indicating the error shall be returned and appropriate additional error information should be returned in the GET response body.

5.3.2.5.3 AmfNon3GppAccessRegistration Information Retrieval

Figure 5.3.2.5.3-1 shows a scenario where the NF service consumer (e.g. NEF) sends a request to the UDM to retrieve the UE's AmfNon3GppAccessRegistration Information. The request contains the UE's identity ($\{ueId\}$) which shall be a GPSI, the type of the requested information ($/registrations/amf-non-3gpp-access$) and query parameters (supported-features).

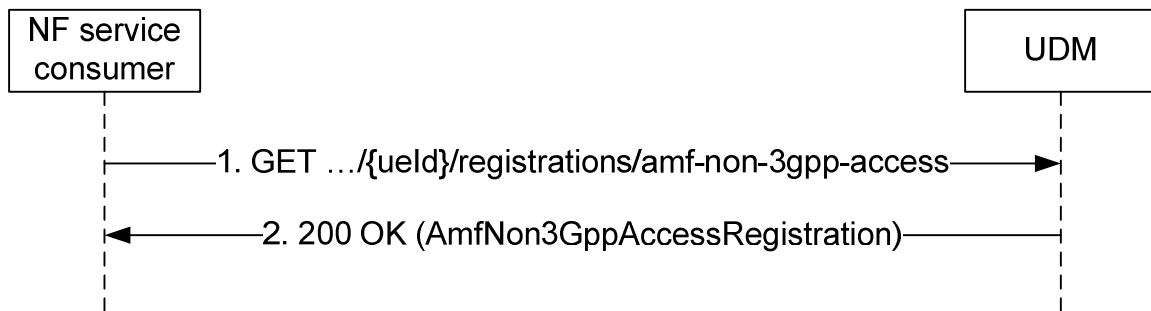

Figure 5.3.2.5.3-1: Requesting a UE's AMF Registration Information for non-3GPP Access

1. The NF service consumer (e.g. NEF) sends a GET request to the resource representing the UE's AMF registration information for non-3GPP access, with query parameters indicating the supported-features.
2. The UDM responds with "200 OK" with the message body containing the UE's AmfNon3GppAccessRegistration.

On failure, the appropriate HTTP status code indicating the error shall be returned and appropriate additional error information should be returned in the GET response body.

5.3.2.5.4 SmfRegistrations Information Retrieval

tbd

5.3.2.5.5 SmsfRegistration Information Retrieval for 3GPP Access

Figure 5.3.2.5.5-1 shows a scenario where the NF service consumer (e.g. NEF) sends a request to the UDM to retrieve the UE's SmsfRegistration Information. The request contains the UE's identity ($\{ueId\}$) which shall be a GPSI, the type of the requested information ($/registrations/smsf-3gpp-access$) and query parameters (supported-features).

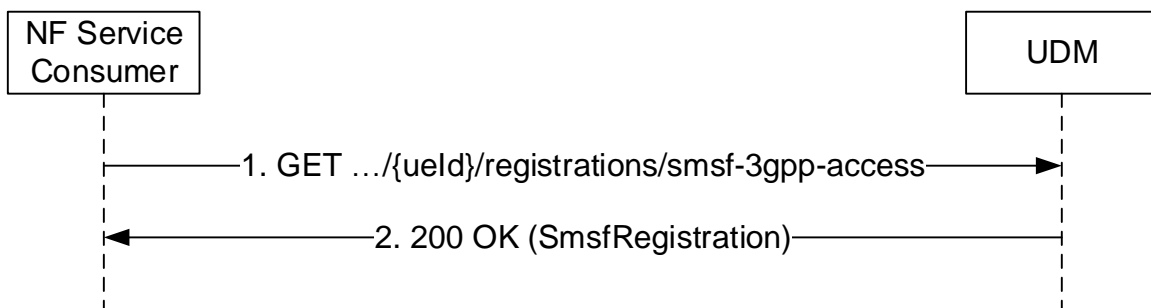

Figure 5.3.2.5.5-1: Requesting a UE's SMSF Registration Information for 3GPP Access

1. The NF service consumer (e.g. NEF) sends a GET request to the resource representing the UE's SMSF registration information for 3GPP access, with query parameters indicating the supported-features.
2. The UDM responds with "200 OK" with the message body containing the UE's SmsfRegistration for 3GPP access.

On failure, the appropriate HTTP status code indicating the error shall be returned and appropriate additional error information should be returned in the GET response body.

5.3.2.5.6 SmsfRegistration Information Retrieval for Non-3GPP Access

Figure 5.3.2.5.6-1 shows a scenario where the NF service consumer (e.g. NEF) sends a request to the UDM to retrieve the UE's SmsfRegistration Information for non-3GPP access. The request contains the UE's identity ($\{ueId\}$) which shall be a GPSI, the type of the requested information ($/registrations/smsf-non-3gpp-access$) and query parameters (supported-features).

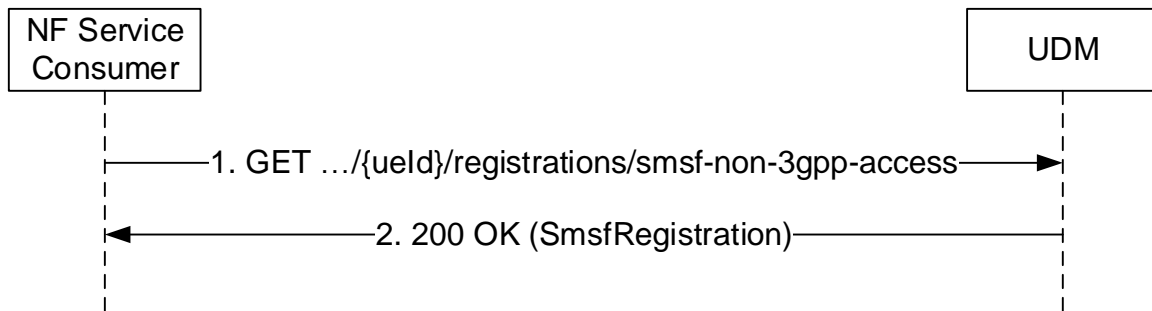

Figure 5.3.2.5.6-1: Requesting a UE's SMSF Registration Information for Non-3GPP Access

1. The NF service consumer (e.g. NEF) sends a GET request to the resource representing the UE's SMSF registration information for non-3GPP access, with query parameters indicating the supported-features.
2. The UDM responds with "200 OK" with the message body containing the UE's SmsfRegistration for non-3GPP access.

On failure, the appropriate HTTP status code indicating the error shall be returned and appropriate additional error information should be returned in the GET response body.

5.3.2.6 Update

5.3.2.6.1 General

The following procedures using the Update service operation are supported:

- Update a parameter (e.g. PEI) in the AMF registration for 3GPP access
- Update a parameter (e.g. PEI) in the AMF registration for non-3GPP access

5.3.2.6.2 Update A Parameter (e.g. PEI) in the AMF Registration For 3GPP Access

Figure 5.3.2.6.2-1 shows a scenario where the AMF sends a request to the UDM to update a parameter within the Amf3GppAccessRegistration resource. The request contains the UE's identity ($\{ueId\}$) which shall be a SUPI and an instruction to modify a parameter (e.g. PEI).

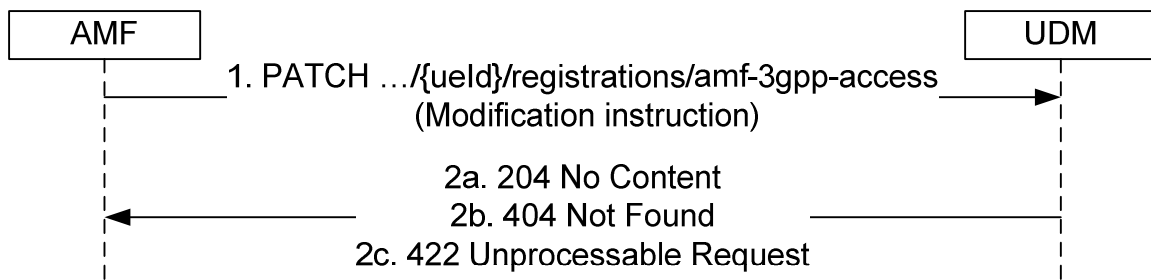

Figure 5.3.2.6.2-1: AMF registration parameter update for 3GPP access

1. The AMF sends a PATCH request to the resource representing the UE's AMF registration for 3GPP access.
- 2a. On success, the UDM responds with "204 No Content".
- 2b. If the resource does not exist e.g. the UE is not registered yet, HTTP status code "404 Not Found" should be returned including additional error information in the response body (in the "ProblemDetails" element).
- 2c. If the resource exists, but the requesting AMF is not the one currently registered for the UE, HTTP status code "422 Unprocessable Request" should be returned including additional error information in the response body (in the "ProblemDetails" element).

On failure, the appropriate HTTP status code indicating the error shall be returned and appropriate additional error information should be returned in the PATCH response body.

5.3.2.6.3 Update A Parameter (e.g. PEI) in the AMF Registration For Non 3GPP Access

Figure 5.3.2.6.3-1 shows a scenario where the AMF sends a request to the UDM to update a parameter within the AmfNon3GppAccessRegistration resource. The request contains the UE's identity ($\{/ueid\}$) which shall be a SUPI and an instruction to modify a parameter (e.g. PEI).

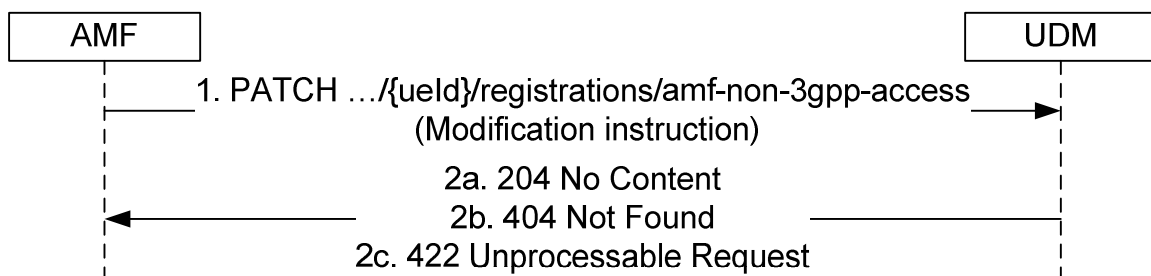

Figure 5.3.2.6.3-1: AMF registration parameter update for non-3GPP access

1. The AMF sends a PATCH request to the resource representing the UE's AMF registration for non-3GPP access.
- 2a. On success, the UDM responds with "204 No Content".
- 2b. If the resource does not exist e.g. the UE is not registered yet, HTTP status code "404 Not Found" should be returned including additional error information in the response body (in the "ProblemDetails" element).
- 2c. If the resource exists, but the requesting AMF is not the one currently registered for the UE, HTTP status code "422 Unprocessable Request" should be returned including additional error information in the response body (in the "ProblemDetails" element).

On failure, the appropriate HTTP status code indicating the error shall be returned and appropriate additional error information should be returned in the PATCH response body.

5.3.2.7 P-CSCF-RestorationNotification

5.3.2.7.1 General

The following procedure using the P-CSCF-RestorationNotification service operation is supported:

- UDM initiated P-CSCF-Restoration

5.3.2.7.2 UDM initiated P-CSCF-Restoration

Figure 5.3.2.7.2-1 shows a scenario where the UDM notifies the registered AMF or SMF about the need for P-CSCF restoration. The request contains the callback URI for P-CSCF restoration as received by the UDM during registration, and P-CSCF Restoration Indication.

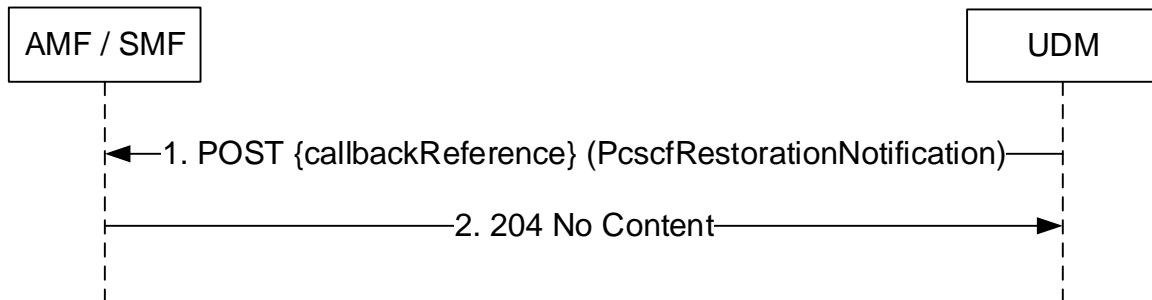

Figure 5.3.2.7.2-1: UDM initiated P-CSCF Restoration

1. The UDM sends a POST request to the callbackReference as provided by the NF service consumer during the registration.
2. The AMF or SMF responds with "204 No Content".

On failure, the appropriate HTTP status code indicating the error shall be returned and appropriate additional error information should be returned in the POST response body.

5.4 Nudm_UEAuthentication Service

5.4.1 Service Description

See 3GPP TS 23.501 [2] table 7.2.5-1.

5.4.2 Service Operations

5.4.2.1 Introduction

For the Nudm_UEAuthentication service the following service operation is defined:

- Get
- ResultConfirmation

The Nudm_UEAuthentication service is used by the AUSF to request the UDM to select an authentication method, calculate a fresh authentication vector (AV) if required for the selected method, and provide it to the AUSF by means of the Get service operation. See 3GPP TS 33.501 [6] subclause 14.2.2.

The Nudm_UEAuthentication service is also used by the AUSF to inform the UDM about the occurrence of a successful or unsuccessful authentication by means of the ResultConfirmation service operation. See 3GPP TS 33.501 [6] subclause 14.2.3.

5.4.2.2 Get

5.4.2.2.1 General

The following procedure using the Get service operation is supported:

- Authentication Information Retrieval

As part of this Authentication Information Retrieval operation, the UDM authorizes or rejects the subscriber to use the service provided by the registered NF, based on subscription data (e.g. roaming restrictions).

5.4.2.2.2 Authentication Information Retrieval

Figure 5.4.2.2.2-1 shows a scenario where the NF service consumer (AUSF) retrieves authentication information for the UE from the UDM (see also 3GPP TS 33.501 [6] subclause 6.1.2). The request contains the UE's identity (supi or suci), the serving network name, and may contain resynchronization info.

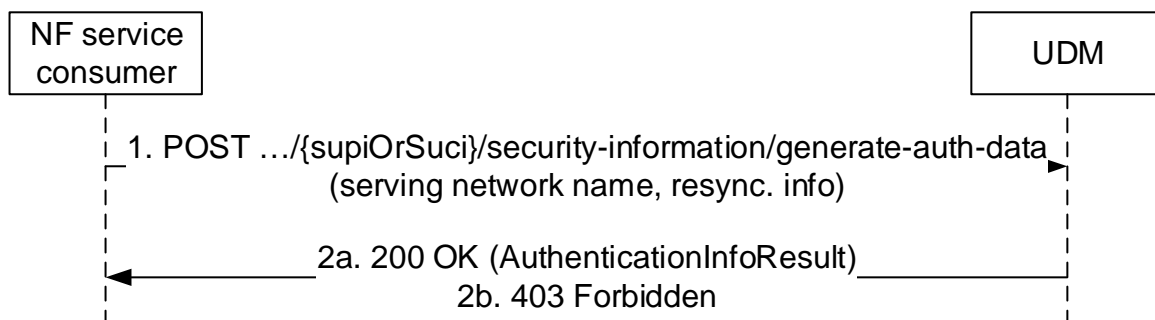

Figure 5.4.2.2.2-1: NF service consumer requesting authentication information

1. The NF service consumer sends a POST request (custom method: generate-auth-data) to the resource representing the UE's security information.
- 2a. The UDM responds with "200 OK" with the message body containing the authentication data information.
- 2b. If the operation cannot be authorized due to e.g UE does not have required subscription data, access barring or roaming restrictions, HTTP status code "403 Forbidden" should be returned including additional error information in the response body (in "ProblemDetails" element).

On failure, the appropriate HTTP status code indicating the error shall be returned and appropriate additional error information should be returned in the POST response body.

5.4.2.3 ResultConfirmationInform

5.4.2.3.1 General

The following procedure using the ResultConfirmation service operation is supported:

- Authentication Confirmation

5.4.2.3.2 Authentication Confirmation

Figure 5.4.2.3.2-1 shows a scenario where the NF service consumer (AUSF) confirms the occurrence of a successful or unsuccessful authentication to the UDM (see also 3GPP TS 33.501 [6] subclause 6.1.4.1a). The request contains the UE's identity (supi), and information about the authentication occurrence (AuthEvent).

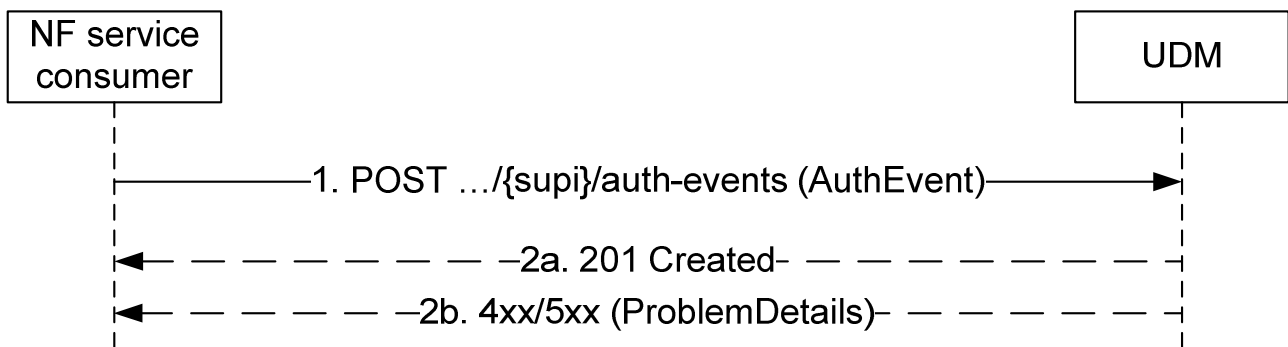

Figure 5.4.2.3.2-1: NF service consumer confirms UE authentication

1. The NF service consumer sends a POST request to the resource representing the UE's authentication events.
- 2a. On success, the UDM responds with "201 Created".
- 2b. On failure, the appropriate HTTP status code indicating the error shall be returned and appropriate additional error information should be returned.

5.5 Nudm_EventExposure Service

5.5.1 Service Description

See 3GPP TS 23.501 [2] table 7.2.5-1.

5.5.2 Service Operations

5.5.2.1 Introduction

For the Nudm_EventExposure service the following service operations are defined:

- Subscribe
- Unsubscribe
- Notify

The Nudm_EventExposure service is used by consumer NFs (e.g. NEF) to subscribe to notifications of event occurrence by means of the Subscribe service operation. For events that can be detected by the AMF, the UDM makes use of the appropriate AMF service operation to subscribe on behalf of the consumer NF (e.g. NEF).

The Nudm_EventExposure service is also used by the consumer NFs (e.g. NEF) that have previously subscribed to notifications, to unsubscribe by means of the Unsubscribe service operation. For events that can be detected by the AMF, the UDM makes use of the appropriate AMF service operation to unsubscribe on behalf of the consumer NF (e.g. NEF).

The Nudm_EventExposure service is also used by the subscribed consumer NFs (e.g. NEF) to get notified by the UDM when a subscribed event occurs at the UDM by means of the Notify service operation. For subscribed events that can occur at the AMF, the consumer NF (e.g. NEF) makes use of the corresponding AMF service operation to get notified by the AMF directly without UDM involvement.

For details see 3GPP TS 23.502 [3] subclause 4.15.

5.5.2.2 Subscribe

5.5.2.2.1 General

The following procedures using the Subscribe service operation are supported:

- Subscribe to Notification of event occurrence

5.5.2.2.2 Subscription to Notification of event occurrence

Figure 5.5.2.2.2-1 shows a scenario where the NF service consumer sends a request to the UDM to subscribe to notifications of event occurrence (see also 3GPP TS 23.502 [3] figure 4.15.3.2.2-1 step 1). The request contains a callback URI, the type of event that is monitored and additional information e.g. event filters and reporting options.

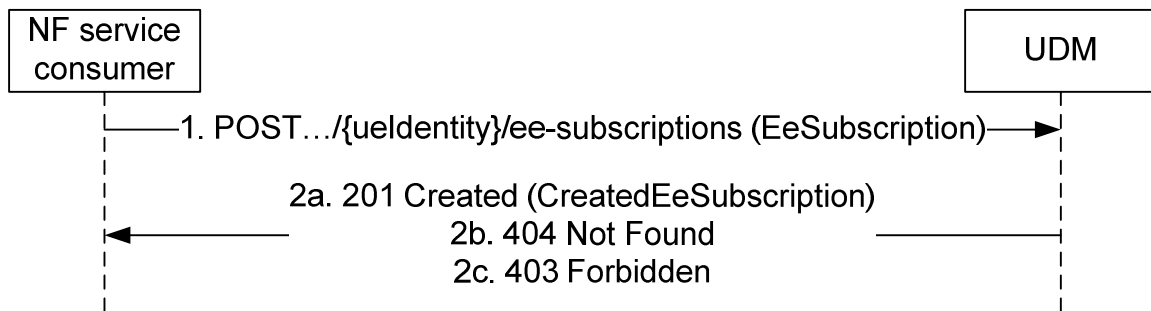

Figure 5.5.2.2.2-1: NF service consumer subscribes to notifications

1. The NF service consumer sends a POST request to the parent resource (collection of subscriptions) (`.../{ueIdentity}/ee-subscriptions`), to create a subscription as present in message body. The values `ueIdentity` shall take are specified in Table 6.4.3.2.2-1. The request may contain an expiry time, suggested by the NF Service Consumer, representing the time upto which the subscription is desired to be kept active and the time after which the subscribed event(s) shall stop generating notifications.
- 2a. On success, the UDM responds with "201 Created" with the message body containing a representation of the created subscription. The Location HTTP header shall contain the URI of the created subscription. If the event subscription was for a group of UEs:
 - The "maxNumOfReports" in the "reportingOptions" IE shall be applicable to each UE in the group;
 - The UDM shall return the number of UEs in that group in the "numberOfUes" IE.

The NF service consumer shall keep track of the maximum number of reports reported for each UE in the event report and when "maxNumOfReports*numberOfUes" limit is reached, the NF service consumer shall initiate the unsubscription of the notification towards the UDM (see subclause 5.5.2.3.2).

The response, based on operator policy, may contain the expiry time, as determined by the UDM, after which the subscription becomes invalid. Once the subscription expires, if the NF Service Consumer wants to keep receiving notifications, it shall create a new subscription in the UDM. The NF Service Producer shall not provide the same expiry time for many subscriptions in order to avoid all of them expiring and recreating the subscription at the same time. If the expiry time is not included in the response, the NF Service Consumer shall not associate an expiry time for the subscription.

- 2b. If the user does not exist, HTTP status code "404 Not Found" shall be returned including additional error information in the response body (in the "ProblemDetails" element).
- 2c. If there is no valid subscription data for the UE, i.e. based on the UE's subscription information monitoring of the requested EventType is not allowed, or the requested EventType is not supported, HTTP status code "403 Forbidden" shall be returned including additional error information in the response body (in the "ProblemDetails" element).

On failure, the appropriate HTTP status code indicating the error shall be returned and appropriate additional error information should be returned in the DELETE response body.

5.5.2.3 Unsubscribe

5.5.2.3.1 General

The following procedures using the Unsubscribe service operation are supported:

- Unsubscribe to Notifications of event occurrence

5.5.2.3.2 Unsubscribe to notifications of event occurrence

Figure 5.2.2.3.2-1 shows a scenario where the NF service consumer sends a request to the UDM to unsubscribe from notifications of event occurrence. The request contains the URI previously received in the Location HTTP header of the response to the subscription.

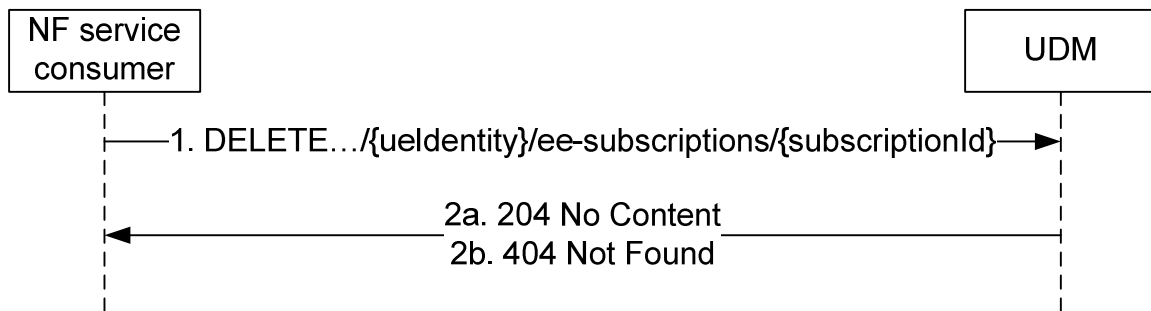

Figure 5.2.2.3.2-1: NF service consumer unsubscribes to notifications

1. The NF service consumer sends a DELETE request to the resource identified by the URI previously received during subscription creation.
- 2a. On success, the UDM responds with "204 No Content".
- 2b. If there is no valid subscription available (e.g. due to an unknown SubscriptionId value), HTTP status code "404 Not Found" shall be returned including additional error information in the response body (in the "ProblemDetails" element).

On failure, the appropriate HTTP status code indicating the error shall be returned and appropriate additional error information should be returned in the DELETE response body.

5.5.2.4 Notify

5.5.2.4.1 General

The following procedures using the Notify service operation are supported:

- Event Occurrence Notification

5.5.2.4.2 Event Occurrence Notification

Figure 5.5.2.4.2-1 shows a scenario where the UDM notifies the NF service consumer (that has subscribed to receive such notification) about occurrence of an event (see also 3GPP TS 23.502 [3] figure 4.15.3.2.2-1 step 4a). The request contains the callbackReference URI as previously received in the EeSubscription (see subclause 6.4.6.2.2).

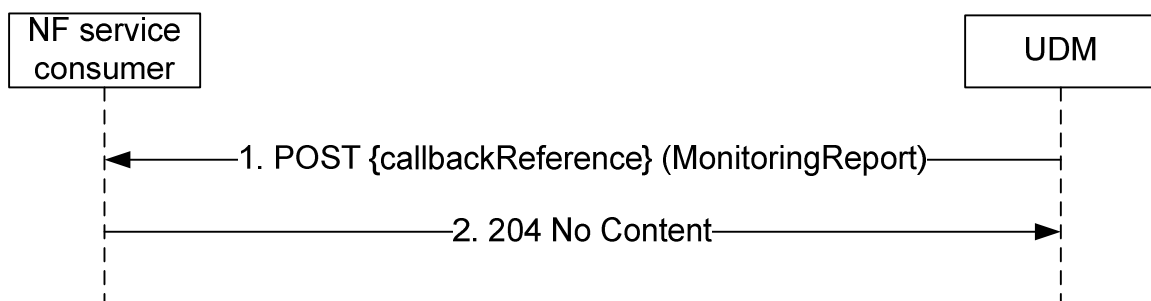

Figure 5.5.2.4.2-1: Event Occurrence Notification

1. The UDM sends a POST request to the callbackReference as provided by the NF service consumer during the subscription.
2. The NF Service Consumer responds with "204 No Content".

On failure, the appropriate HTTP status code indicating the error shall be returned and appropriate additional error information should be returned in the POST response body.

5.6 Nudm_ParameterProvision Service

5.6.1 Service Description

See 3GPP TS 23.501 [2] table 7.2.5-1.

5.6.2 Service Operations

5.6.2.1 Introduction

For the Nudm_ParameterProvision service the following service operations are defined:

- Update

The Nudm_ParameterProvision service is used by consumer NFs (e.g. NEF) to update a UE's subscription data by means of the Update service operation.

For details see 3GPP TS 23.502 [3] subclause 4.15.6.2.

Editor's Note: It is ffs how the UDM can authorize Update requests

Editor's Note: A service operation for data retrieval is ffs

5.6.2.2 Update

5.6.2.2.1 General

The following procedures using the Update service operation are supported:

- Subscription data update

5.6.2.2.2 Subscription data update

Figure 5.6.2.2.2-1 shows a scenario where the NF service consumer sends a request to the UDM to update a UE's subscription data (see also 3GPP TS 23.502 [3] figure 4.15.6.2-1 step 2). The request contains the identifier of the UE's parameter provision data (.../{gpsi}/pp-data) and the modification instructions.

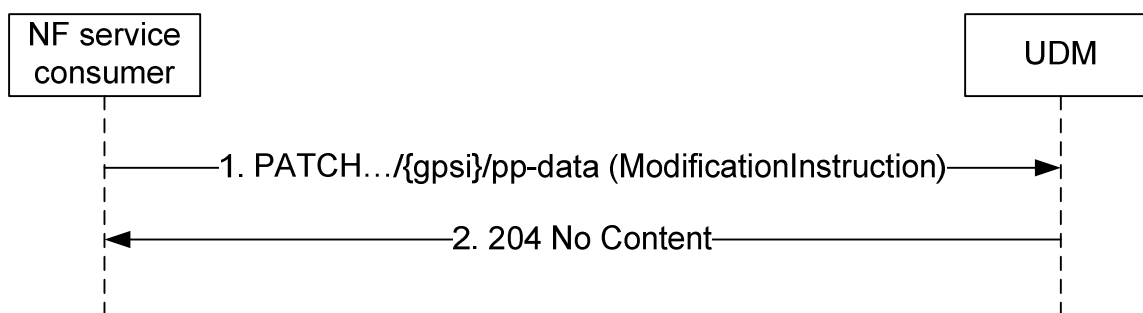

Figure 5.6.2.2.2-1: NF service consumer updates subscription data

1. The NF service consumer sends a PATCH request to the resource that represents a UE's modifiable subscription data.
2. The UDM responds with "204 No Content".

On failure, the appropriate HTTP status code indicating the error shall be returned and appropriate additional error information should be returned in the PATCH response body.

6 API Definitions

6.1 Nudm_SubscriberDataManagement Service API

6.1.1 API URI

URIs of this API shall have the following root:

```
{apiRoot}/{apiName}/{apiVersion}/
```

where the "apiRoot" is defined in subclause 4.4.1 of 3GPP TS 29.501 [5], "apiName" shall be set to "nudm-sdm" and the "apiVersion" shall be set to "v1" for the current version of this specification.

6.1.2 Usage of HTTP

6.1.2.1 General

HTTP/2, as defined in IETF RFC 7540 [13], shall be used as specified in clause 5 of 3GPP TS 29.500 [4].

HTTP/2 shall be transported as specified in subclause 5.3 of 3GPP TS 29.500 [4].

HTTP messages and bodies for the Nudm_SDM service shall comply with the OpenAPI [14] specification contained in Annex A2.

6.1.2.2 HTTP standard headers

6.1.2.2.1 General

The usage of HTTP standard headers shall be supported as specified in subclause 5.2.2 of 3GPP TS 29.500 [4].

6.1.2.2.2 Content type

The following content types shall be supported:

JSON, as defined in IETF RFC 8259 [15], signalled by the content type "application/json".

The Problem Details JSON Object (IETF RFC 7807 [16]) signalled by the content type "application/problem+json"

6.1.2.2.3 Cache-Control

As described in IETF RFC 7234 [26] section 5.2, a "Cache-Control" header should be included in HTTP responses except for non-cacheable resources (e.g. UeContextInSmsfData). If it is included, it shall contain a "max-age" value, indicating the amount of time in seconds after which the received response is considered stale.

The "max-age" value shall be configurable by operator policy.

6.1.2.2.4 ETag

As described in IETF RFC 7232 [25] section 2.32, an "ETag" (entity-tag) header should be included in HTTP responses except for non-cacheable resources (e.g. UeContextInSmsfData) to allow an NF Service Consumer performing a conditional request with "If-None-Match" header. If it is included, it shall contain a server-generated strong validator, that allows further matching of this value (included in subsequent client requests) with a given resource representation stored in the server or in a cache.

6.1.2.2.5 If-None-Match

As described in IETF RFC 7232 [25] section 3.2, an NF Service Consumer may issue conditional GET request towards UDM by including an "If-None-Match" header in HTTP requests containing one or several entity tags received in previous responses for the same resource.

6.1.2.2.6 Last-Modified

As described in IETF RFC 7232 [25] section 2.2, a "Last-Modified" header should be included in HTTP responses except for non-cacheable resources (e.g. SorAck) to allow an NF Service Consumer performing a conditional request with "If-Modified-Since" header.

6.1.2.2.7 If-Modified-Since

As described in IETF RFC 7232 [25] section 3.3, an NF Service Consumer may issue conditional GET request towards UDM, by including an "If-Modified-Since" header in HTTP requests.

6.1.2.2.8 When to Use Entity-Tags and Last-Modified Dates

Both "ETag" and "Last-Modified" headers should be sent in the same HTTP response as stated in IETF RFC 7232 [25] section 2.4.

NOTE: "ETag" is a stronger validator than "Last-Modified" and is preferred.

If the NF Service Producer included an "ETag" header with the resource then a conditional request for this resource shall be performed with the "If-None-Match" header.

6.1.2.3 HTTP custom headers

6.1.2.3.1 General

The usage of HTTP custom headers shall be supported as specified in subclause 5.2.3 of 3GPP TS 29.500 [4].

6.1.3 Resources

6.1.3.1 Overview

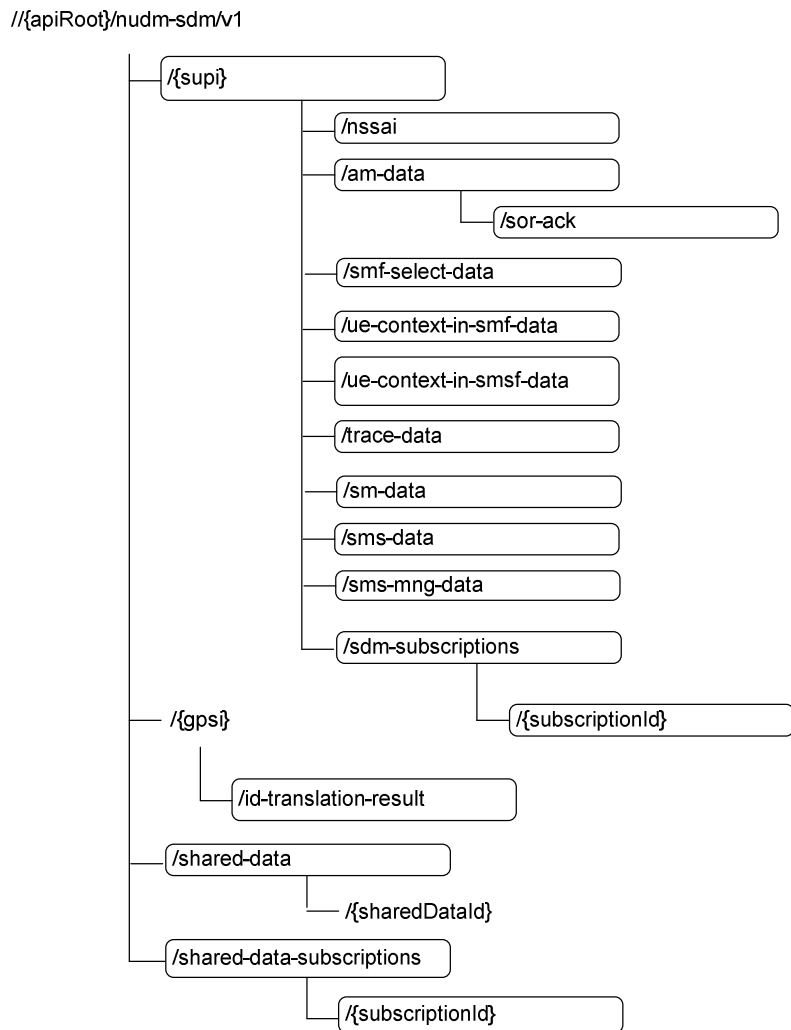

Figure 6.1.3.1-1: Resource URI structure of the nudm-sdm API

Table 6.1.3.1-1 provides an overview of the resources and applicable HTTP methods.

Table 6.1.3.1-1: Resources and methods overview

Resource name (Archetype)	Resource URI	HTTP method or custom operation	Description
Supi (Document)	/{supi}	GET	Retrieve UE's subscription data
Nssai (Document)	/{supi}/nssai	GET	Retrieve the UE's subscribed Network Slice Selection Assistance Information
AccessAndMobilitySubscriptionData (Document)	/{supi}/am-data	GET	Retrieve the UE's subscribed Access and Mobility Data
SorAck (Document)	/{supi}/am-data/sor-ack	PUT	Providing acknowledgement of Steering of Roaming
SmfSelectionSubscriptionData (Document)	/{supi}/smf-select-data	GET	Retrieve the UE's subscribed SMF Selection Data
UeContextInSmfData (Document)	/{supi}/ue-context-in-smf-data	GET	Retrieve the UE's Context in SMF Data
SessionManagementSubscriptionData (Document)	/{supi}/sm-data	GET	Retrieve the UE's session management subscription data
SMSSubscriptionData (Document)	/{supi}/sms-data	GET	Retrieve the UE's SMS subscription data
SMSManagementSubscriptionData (Document)	/{supi}/sms-mng-data	GET	Retrieve the UE's SMS management subscription data
SdmSubscriptions (Collection)	/{supi}/sdm-subscriptions	POST	Create a subscription
Individual subscription (Document)	/{supi}/sdm-subscriptions/{subscriptionId}	DELETE	Delete the subscription identified by {subscriptionId}, i.e. unsubscribe
IdTranslationResult (Document)	/{gpsi}/id-translation-result	GET	Retrieve a UE's SUPI
UeContextInSmsfData (Document)	/{supi}/ue-context-in-smsf-data	GET	Retrieve the UE's Context in SMSF Data
TraceData (Document)	/{supi}/trace-data	GET	Retrieve Trace Configuration Data
SharedData (Collection)	/shared-data	GET	Retrieve shared data
SharedDataSubscriptions (Collection)	/shared-data-subscriptions	POST	Create a subscription
SharedDataIndividual subscription (Document)	/shared-data-subscriptions/{subscriptionId}	DELETE	Delete the subscription identified by {subscriptionId}, i.e. unsubscribe

6.1.3.2 Resource: Nssai

6.1.3.2.1 Description

This resource represents the subscribed Nssai for a SUPI. It is queried by the AMF before registering, and is used to assist network slice selection. See 5.2.2.2 and 3GPP TS 23.501 [2] clause 5.15.3.

6.1.3.2.2 Resource Definition

Resource URI: {apiRoot}/nudm-sdm/v1/{supi}/nssai

This resource shall support the resource URI variables defined in table 6.1.3.2.2-1.

Table 6.1.3.2.2-1: Resource URI variables for this resource

Name	Definition
apiRoot	See subclause 6.1.1
supi	Represents the Subscription Permanent Identifier (see 3GPP TS 23.501 [2] clause 5.9.2) pattern: "(imsi-[0-9]{5,15} nai-.[+.])"

6.1.3.2.3 Resource Standard Methods

6.1.3.2.3.1 GET

This method shall support the URI query parameters specified in table 6.1.3.2.3.1-1.

Table 6.1.3.2.3.1-1: URI query parameters supported by the GET method on this resource

Name	Data type	P	Cardinality	Description
supported-features	SupportedFeatures	O	0..1	see 3GPP TS 29.500 [4] subclause 6.6
plmn-id	PlmnId	O	0..1	PLMN identity of the PLMN serving the UE

If "plmn-id" is included, UDM shall return the Subscribed S-NSSAIs which the UE is subscribed to use in the PLMN identified by "plmn-id".

If "plmn-id" is not included, UDM shall return the Subscribed S-NSSAIs for HPLMN.

This method shall support the request data structures specified in table 6.1.3.2.3.1-2 and the response data structures and response codes specified in table 6.1.3.2.3.1-3.

Table 6.1.3.2.3.1-2: Data structures supported by the GET Request Body on this resource

Data type	P	Cardinality	Description
n/a			

Table 6.1.3.2.3.1-3: Data structures supported by the GET Response Body on this resource

Data type	P	Cardinality	Response codes	Description
Nssai	M	1	200 OK	Upon success, a response body containing the NSSAI shall be returned.
ProblemDetails	M	1	404 Not Found	The "cause" attribute shall be set to one of the following application errors: - USER_NOT_FOUND - DATA_NOT_FOUND
NOTE: In addition common data structures as listed in table 6.1.7-1 are supported.				

6.1.3.3 Resource: SdmSubscriptions

6.1.3.3.1 Description

This resource is used to represent subscriptions to notifications.

6.1.3.3.2 Resource Definition

Resource URI: {apiRoot}/nudm-sdm/v1/{supi}/sdm-subscriptions

This resource shall support the resource URI variables defined in table 6.1.3.3.2-1.

Table 6.1.3.3.2-1: Resource URI variables for this resource

Name	Definition
apiRoot	See subclause 6.1.1
supi	Represents the Subscription Permanent Identifier (see 3GPP TS 23.501 [2] clause 5.9.2) pattern: "(imsi-[0-9]{5,15} nai-.[+.])"

6.1.3.3.3 Resource Standard Methods

6.1.3.3.3.1 POST

This method shall support the URI query parameters specified in table 6.1.3.3.3.1-1.

Table 6.1.3.3.3.1-1: URI query parameters supported by the POST method on this resource

Name	Data type	P	Cardinality	Description
n/a				

This method shall support the request data structures specified in table 6.1.3.3.3.1-2 and the response data structures and response codes specified in table 6.1.3.3.3.1-3.

Table 6.1.3.3.3.1-2: Data structures supported by the POST Request Body on this resource

Data type	P	Cardinality	Description
SdmSubscription	M	1	The subscription that is to be created.

Table 6.1.3.3.3.1-3: Data structures supported by the POST Response Body on this resource

Data type	P	Cardinality	Response codes	Description
SdmSubscription	M	1	201 Created	Upon success, a response body containing a representation of the created Individual subscription resource shall be returned. The HTTP response shall include a "Location" HTTP header that contains the resource URI of the created resource. When stateless UDM is deployed, the stateless UDM may use an FQDN identifying the UDM group to which the UDM belongs as the host part of the resource URI.
ProblemDetails	M	1	404 Not Found	The "cause" attribute shall be set to the following application error: - USER_NOT_FOUND
ProblemDetails	M	1	501 Not Implemented	The "cause" attribute shall be set to the following application error: - UNSUPPORTED_RESOURCE_URI

NOTE: In addition common data structures as listed in table 6.1.7-1 are supported.

NOTE: In the scenario of stateless UDM deployment, it is assumed that stateless UDMs are organized into several UDM groups, and for each UDM group an FQDN can be allocated.

6.1.3.4 Resource: Individual subscription

6.1.3.4.1 Description

This resource is used to represent an individual subscription to notifications.

6.1.3.4.2 Resource Definition

Resource URI: {apiRoot}/nudm-sdm/v1/{supi}/sdm-subscriptions/{subscriptionId}

This resource shall support the resource URI variables defined in table 6.1.3.4.2-1.

Table 6.1.3.4.2-1: Resource URI variables for this resource

Name	Definition
apiRoot	See subclause 6.1.1
supi	Represents the Subscription Permanent Identifier (see 3GPP TS 23.501 [2] clause 5.9.2) pattern: "(imsi-[0-9]{5,15} nai-.[.]+)"
subscriptionId	The subscriptionId identifies an individual subscription to notifications. The value is allocated by the UDM during creation of the Subscription resource.

6.1.3.4.3 Resource Standard Methods

6.1.3.4.3.1 DELETE

This method shall support the URI query parameters specified in table 6.1.3.4.3.1-1.

Table 6.1.3.4.3.1-1: URI query parameters supported by the DELETE method on this resource

Name	Data type	P	Cardinality	Description
n/a				

This method shall support the request data structures specified in table 6.1.3.4.3.1-2 and the response data structures and response codes specified in table 6.1.3.4.3.1-3.

Table 6.1.3.4.3.1-2: Data structures supported by the Delete Request Body on this resource

Data type	P	Cardinality	Description
n/a			The request body shall be empty.

Table 6.1.3.4.3.1-3: Data structures supported by the DELETE Response Body on this resource

Data type	P	Cardinality	Response codes	Description
n/a			204 No Content	Upon success, an empty response body shall be returned.
NOTE: In addition common data structures as listed in table 6.1.7-1 are supported.				

6.1.3.5 Resource: AccessAndMobilitySubscriptionData

6.1.3.5.1 Description

This resource represents the subscribed Access and Mobility Data for a SUPI. It is queried by the AMF after registering.

6.1.3.5.2 Resource Definition

Resource URI: {apiRoot}/nudm-sdm/v1/{supi}/am-data

This resource shall support the resource URI variables defined in table 6.1.3.5.2-1.

Table 6.1.3.5.2-1: Resource URI variables for this resource

Name	Definition
apiRoot	See subclause 6.1.1
supi	Represents the Subscription Permanent Identifier (see 3GPP TS 23.501 [2] clause 5.9.2) pattern: "(imsi-[0-9]{5,15} nai-.[.]+)"

6.1.3.5.3 Resource Standard Methods

6.1.3.5.3.1 GET

This method shall support the URI query parameters specified in table 6.1.3.5.3.1-1.

Table 6.1.3.5.3.1-1: URI query parameters supported by the GET method on this resource

Name	Data type	P	Cardinality	Description
supported-features	SupportedFeatures	O	0..1	see 3GPP TS 29.500 [4] subclause 6.6
plmn-id	PlmnId	O	0..1	PLMN identity of the PLMN serving the UE

If "plmn-id" is included, UDM shall return the Access and Mobility Data for the SUPI associated to the PLMN identified by "plmn-id".

If "plmn-id" is not included, UDM shall return the Access and Mobility Data for the SUPI associated to the HPLMN.

This method shall support the request data structures specified in table 6.1.3.5.3.1-2 and the response data structures and response codes specified in table 6.1.3.5.3.1-3.

Table 6.1.3.5.3.1-2: Data structures supported by the GET Request Body on this resource

Data type	P	Cardinality	Description
n/a			

Table 6.1.3.5.3.1-3: Data structures supported by the GET Response Body on this resource

Data type	P	Cardinality	Response codes	Description
AccessAndMobilitySubscriptionData	M	1	200 OK	Upon success, a response body containing the Access and Mobility Subscription Data shall be returned.
ProblemDetails	M	1	404 Not Found	The "cause" attribute shall be set to one of the following application errors: - USER_NOT_FOUND - DATA_NOT_FOUND
NOTE: In addition common data structures as listed in table 6.1.7-1 are supported.				

6.1.3.6 Resource: SmfSelectionSubscriptionData

6.1.3.6.1 Description

This resource represents the subscribed SMF Selection Data for a SUPI. It is queried by the AMF after registering.

6.1.3.6.2 Resource Definition

Resource URI: {apiRoot}/nudm-sdm/v1/{supi}/smf-select-data

This resource shall support the resource URI variables defined in table 6.1.3.6.2-1.

Table 6.1.3.6.2-1: Resource URI variables for this resource

Name	Definition
apiRoot	See subclause 6.1.1
supi	Represents the Subscription Permanent Identifier (see 3GPP TS 23.501 [2] clause 5.9.2) pattern: "(imsi-[0-9]{5,15} nai-.+ .+)")

6.1.3.6.3 Resource Standard Methods

6.1.3.6.3.1 GET

This method shall support the URI query parameters specified in table 6.1.3.6.3.1-1.

Table 6.1.3.6.3.1-1: URI query parameters supported by the GET method on this resource

Name	Data type	P	Cardinality	Description
supported-features	SupportedFeatures	O	0..1	see 3GPP TS 29.500 [4] subclause 6.6
plmn-id	PlmnId	O	0..1	PLMN identity of the PLMN serving the UE

If "plmn-id" is included, UDM shall return the SMF Selection Subscription Data for the SUPI associated to the PLMN identified by "plmn-id".

If "plmn-id" is not included, UDM shall return the SMF Selection Subscription Data for the SUPI associated to the HPLMN.

This method shall support the request data structures specified in table 6.1.3.6.3.1-2 and the response data structures and response codes specified in table 6.1.3.6.3.1-3.

Table 6.1.3.6.3.1-2: Data structures supported by the GET Request Body on this resource

Data type	P	Cardinality	Description
n/a			

Table 6.1.3.6.3.1-3: Data structures supported by the GET Response Body on this resource

Data type	P	Cardinality	Response codes	Description
SmfSelectionSubscriptionData	M	1	200 OK	Upon success, a response body containing the SMF Selection Subscription Data shall be returned.
ProblemDetails	M	1	404 Not Found	The "cause" attribute shall be set to one of the following application errors: - USER_NOT_FOUND - DATA_NOT_FOUND

NOTE: In addition common data structures as listed in table 6.1.7-1 are supported.

6.1.3.7 Resource: UeContextInSmfData

6.1.3.7.1 Description

This resource represents the allocated SMFs for a SUPI. It is queried by the AMF after registering.

6.1.3.7.2 Resource Definition

Resource URI: {apiRoot}/nudm-sdm/v1/{supi}/ue-context-in-smf-data

This resource shall support the resource URI variables defined in table 6.1.3.7.2-1.

Table 6.1.3.7.2-1: Resource URI variables for this resource

Name	Definition
apiRoot	See subclause 6.1.1
supi	Represents the Subscription Permanent Identifier (see 3GPP TS 23.501 [2] clause 5.9.2) pattern: "(imsi-[0-9]{5,15} nai-.+ .+)")

6.1.3.7.3 Resource Standard Methods

6.1.3.7.3.1 GET

This method shall support the URI query parameters specified in table 6.1.3.7.3.1-1.

Table 6.1.3.7.3.1-1: URI query parameters supported by the GET method on this resource

Name	Data type	P	Cardinality	Description
supported-features	SupportedFeatures	O	0..1	see 3GPP TS 29.500 [4] subclause 6.6

This method shall support the request data structures specified in table 6.1.3.7.3.1-2 and the response data structures and response codes specified in table 6.1.3.7.3.1-3.

Table 6.1.3.7.3.1-2: Data structures supported by the GET Request Body on this resource

Data type	P	Cardinality	Description
n/a			

Table 6.1.3.7.3.1-3: Data structures supported by the GET Response Body on this resource

Data type	P	Cardinality	Response codes	Description
UeContextInSmfData	M	1	200 OK	Upon success, a response body containing the UeContextInSmfData shall be returned.
ProblemDetails	M	1	404 Not Found	The "cause" attribute shall be set to one of the following application errors: - USER_NOT_FOUND - DATA_NOT_FOUND
NOTE: In addition common data structures as listed in table 6.1.7-1 are supported.				

6.1.3.8 Resource: SessionManagementSubscriptionData

6.1.3.8.1 Description

This resource represents the Session Management subscription data for a SUPI. It is queried by the SMF during session setup, using query parameters representing the selected network slice and the DNN. The SMF is responsible for enforcing the user session management subscription data.

6.1.3.8.2 Resource Definition

Resource URI: {apiRoot}/nudm-sdm/v1/{supi}/sm-data

This resource shall support the resource URI variables defined in table 6.1.3.8.2-1.

Table 6.1.3.8.2-1: Resource URI variables for this resource

Name	Definition
apiRoot	See subclause 6.1.1
supi	Represents the Subscription Permanent Identifier (see 3GPP TS 23.501 [2] clause 5.9.2) pattern: "(imsi-[0-9]{5,15} nai-.+ .+)")

6.1.3.8.3 Resource Standard Methods

6.1.3.8.3.1 GET

This method shall support the URI query parameters specified in table 6.1.3.8.3.1-1.

Table 6.1.3.8.3.1-1: URI query parameters supported by the GET method on this resource

Name	Data type	P	Cardinality	Description
supported-features	SupportedFeatures	O	0..1	see 3GPP TS 29.500 [4] subclause 6.6
single-nssai	Snssai	O	0..1	
dnn	Dnn	O	0..1	
plmn-id	PlmnId	O	0..1	PLMN identity of the PLMN serving the UE

JSON objects (such as Snssai, PlmnId...) shall be included directly as part of the URI query parameters by specifying in the OpenAPI file that the "Content-Type" of such parameters is "application/json".

If "singleNssai" is not included, and "dnn" is not included, UDM shall return all DNN configurations for all network slice(s).

If "singleNssai" is included, and "dnn" is not included, UDM shall return all DNN configurations for the requested network slice identified by "singleNssai".

If "singleNssai" is not included, and "dnn" is included, UDM shall return all DNN configurations identified by "dnn" for all network slices where such DNN is available.

If "singleNssai" is included, and "dnn" is included, UDM shall return the DNN configuration identified by "dnn", if such DNN is available in the network slice identified by "singleNssai".

For all the combinations about the inclusion of "dnn" and "singleNssai" as URI query parameters, if "plmn-id" is included, UDM shall return the configurations for the DNN and network slices associated to the PLMN identified by "plmn-id". Otherwise (i.e. if "plmn-id" is not included), UDM shall return the configurations for the DNN and network slices associated to the HPLMN.

This method shall support the request data structures specified in table 6.1.3.8.3.1-2 and the response data structures and response codes specified in table 6.1.3.8.3.1-3.

Table 6.1.3.8.3.1-2: Data structures supported by the GET Request Body on this resource

Data type	P	Cardinality	Description
n/a			

Table 6.1.3.8.3.1-3: Data structures supported by the GET Response Body on this resource

Data type	P	Cardinality	Response codes	Description
array(SessionManagementSubscriptionData)	M	1..N	200 OK	Upon success, a response body containing the Session Management Subscription data shall be returned.
ProblemDetails	M	1	404 Not Found	The "cause" attribute shall be set to one of the following application errors: - USER_NOT_FOUND - DATA_NOT_FOUND
NOTE: In addition common data structures as listed in table 6.1.7-1 are supported.				

6.1.3.9 Resource: SMSSubscriptionData

6.1.3.9.1 Description

This resource represents the subscribed SMS Subscription Data for a SUPI. It is queried by the AMF after registering.

6.1.3.9.2 Resource Definition

Resource URI: {apiRoot}/nudm-sdm/v1/{supi}/sms-data

This resource shall support the resource URI variables defined in table 6.1.3.9.2-1.

Table 6.1.3.9.2-1: Resource URI variables for this resource

Name	Definition
apiRoot	See subclause 6.1.1
supi	Represents the Subscription Permanent Identifier (see 3GPP TS 23.501 [2] clause 5.9.2) pattern: "(imsi-[0-9]{5,15} nai-.+ .+)")

6.1.3.9.3 Resource Standard Methods

6.1.3.9.3.1 GET

This method shall support the URI query parameters specified in table 6.1.3.9.3.1-1.

Table 6.1.3.9.3.1-1: URI query parameters supported by the GET method on this resource

Name	Data type	P	Cardinality	Description
plmn-id	PlmnId	C	0..1	if absent, H-PLMN ID is used as default
supported-features	SupportedFeatures	O	0..1	see 3GPP TS 29.500 [4] subclause 6.6

This method shall support the request data structures specified in table 6.1.3.9.3.1-2 and the response data structures and response codes specified in table 6.1.3.9.3.1-3.

Table 6.1.3.9.3.1-2: Data structures supported by the GET Request Body on this resource

Data type	P	Cardinality	Description
n/a			

Table 6.1.3.9.3.1-3: Data structures supported by the GET Response Body on this resource

Data type	P	Cardinality	Response codes	Description
SmsSubscriptionData	M	1	200 OK	Upon success, a response body containing the SMS Subscription Data shall be returned.
ProblemDetails	M	1	404 Not Found	The "cause" attribute shall be set to one of the following application errors: - USER_NOT_FOUND - DATA_NOT_FOUND
NOTE: In addition common data structures as listed in table 6.1.7-1 are supported.				

6.1.3.10 Resource: SMSManagementSubscriptionData

6.1.3.10.1 Description

This resource represents the subscribed SMS Management Data for a SUPI. It is queried by the SMSF after registering.

6.1.3.10.2 Resource Definition

Resource URI: {apiRoot}/nudm-sdm/v1/{supi}/sms-mng-data

This resource shall support the resource URI variables defined in table 6.1.3.10.2-1.

Table 6.1.3.10.2-1: Resource URI variables for this resource

Name	Definition
apiRoot	See subclause 6.1.1
supi	Represents the Subscription Permanent Identifier (see 3GPP TS 23.501 [2] clause 5.9.2) pattern: "(imsi-[0-9]{5,15})nai-.[.+]")

6.1.3.10.3 Resource Standard Methods

6.1.3.10.3.1 GET

This method shall support the URI query parameters specified in table 6.1.3.10.3.1-1.

Table 6.1.3.10.3.1-1: URI query parameters supported by the GET method on this resource

Name	Data type	P	Cardinality	Description
plmn-id	Plmnlid	C	0..1	if absent, H-PLMN ID is used as default
supported-features	SupportedFeatures	O	0..1	see 3GPP TS 29.500 [4] subclause 6.6

This method shall support the request data structures specified in table 6.1.3.10.3.1-2 and the response data structures and response codes specified in table 6.1.3.10.3.1-3.

Table 6.1.3.10.3.1-2: Data structures supported by the GET Request Body on this resource

Data type	P	Cardinality	Description
n/a			

Table 6.1.3.10.3.1-3: Data structures supported by the GET Response Body on this resource

Data type	P	Cardinality	Response codes	Description
SmsManagementSubscriptionData	M	1	200 OK	Upon success, a response body containing the SMS Management Subscription Data shall be returned.
ProblemDetails	M	1	404 Not Found	The "cause" attribute shall be set to one of the following application errors: - USER_NOT_FOUND - DATA_NOT_FOUND

NOTE: In addition common data structures as listed in table 6.1.7-1 are supported.

6.1.3.11 Resource: Supi

6.1.3.11.1 Description

This resource represents the subscription profile of the subscriber identified by a given SUPI.

6.1.3.11.2 Resource Definition

Resource URI: {apiRoot}/nudm-sdm/v1/{supi}

This resource shall support the resource URI variables defined in table 6.1.3.11.2-1.

Table 6.1.3.11.2-1: Resource URI variables for this resource

Name	Definition
apiRoot	See subclause 6.1.1
supi	Represents the Subscription Permanent Identifier (see 3GPP TS 23.501 [2] clause 5.9.2) pattern: "(imsi-[0-9]{5,15})nai-+)"

6.1.3.11.3 Resource Standard Methods

6.1.3.11.3.1 GET

This method shall support the URI query parameters specified in table 6.1.3.11.3.1-1.

NOTE: The retrieval of these data sets can also be achieved by sending individual GET requests to the corresponding sub-resources under the {supi} resource. When multiple data sets need to be retrieved by the NF Service consumer, it is recommended to use a single GET request with query parameters rather than issuing multiple GET requests.

Table 6.1.3.11.3.1-1: URI query parameters supported by the GET method on this resource

Name	Data type	P	Cardinality	Description
dataset-names	array(DataSetName)	M	1..N	
plmn-id	PlmnId	C	0..1	if absent, H-PLMN ID is used as default
supported-features	SupportedFeatures	O	0..1	see 3GPP TS 29.500 [4] subclause 6.6

This method shall support the request data structures specified in table 6.1.3.11.3.1-2 and the response data structures and response codes specified in table 6.1.3.11.3.1-3.

Table 6.1.3.11.3.1-2: Data structures supported by the GET Request Body on this resource

Data type	P	Cardinality	Description
n/a			

Table 6.1.3.11.3.1-3: Data structures supported by the GET Response Body on this resource

Data type	P	Cardinality	Response codes	Description
SubscriptionData Sets	M	1	200 OK	Upon success, a response body containing the requested data sets shall be returned.
ProblemDetails	M	1	404 Not Found	The "cause" attribute shall be set to one of the following application errors: - USER_NOT_FOUND - DATA_NOT_FOUND

NOTE: In addition common data structures as listed in table 6.1.7-1 are supported.

6.1.3.12 Resource: IdTranslationResult

6.1.3.12.1 Description

This resource represents the SUPI. It is queried by the NEF for GPSI to SUPI translation. See 3GPP TS 23.502 [3] clause 4.13.2.2.

6.1.3.12.2 Resource Definition

Resource URI: {apiRoot}/nudm-sdm/v1/{gpsi}/id-translation-result

This resource shall support the resource URI variables defined in table 6.1.3.12.2-1.

Table 6.1.3.12.2-1: Resource URI variables for this resource

Name	Definition
apiRoot	See subclause 6.1.1
gpsi	Represents the Generic Public Subscription Identifier (see 3GPP TS 23.501 [2] subclause 5.9.8) pattern: "(msisdn-[0-9]{5,15} extid-[^@]+@[^@]+ .+)"

6.1.3.12.3 Resource Standard Methods

6.1.3.12.3.1 GET

This method shall support the URI query parameters specified in table 6.1.3.12.3.1-1.

Table 6.1.3.12.3.1-1: URI query parameters supported by the GET method on this resource

Name	Data type	P	Cardinality	Description
supported-features	SupportedFeatures	O	0..1	see 3GPP TS 29.500 [4] subclause 6.6

This method shall support the request data structures specified in table 6.1.3.12.3.1-2 and the response data structures and response codes specified in table 6.1.3.12.3.1-3.

Table 6.1.3.12.3.1-2: Data structures supported by the GET Request Body on this resource

Data type	P	Cardinality	Description
n/a			

Table 6.1.3.12.3.1-3: Data structures supported by the GET Response Body on this resource

Data type	P	Cardinality	Response codes	Description
IdTranslationResult	M	1	200 OK	Upon success, a response body containing the SUPI and optionally the MSISDN shall be returned.
ProblemDetails	M	1	404 Not Found	The "cause" attribute shall be set to one of the following application errors: - USER_NOT_FOUND - DATA_NOT_FOUND

NOTE: In addition common data structures as listed in table 6.1.7-1 are supported.

6.1.3.13 Resource: SorAck

6.1.3.13.1 Description

This resource represents the acknowledgement of the SoR for a SUPI.

6.1.3.13.2 Resource Definition

Resource URI: {apiRoot}/nudm-sdm/v1/{supi}/am-data/sor-ack

This resource shall support the resource URI variables defined in table 6.1.3.13.2-1.

Table 6.1.3.13.2-1: Resource URI variables for this resource

Name	Definition
apiRoot	See subclause 6.1.1
supi	Represents the Subscription Permanent Identifier (see 3GPP TS 23.501 [2] clause 5.9.2) pattern: "(imsi-[0-9]{5,15} nai-.+ .+)")

6.1.3.13.3 Resource Standard Methods

6.1.3.13.3.1 PUT

This method shall support the URI query parameters specified in table 6.1.3.13.3.1-1.

Table 6.1.3.13.3.1-1: URI query parameters supported by the PUT method on this resource

Name	Data type	P	Cardinality	Description
n/a				

This method shall support the request data structures specified in table 6.1.3.13.3.1-2 and the response data structures and response codes specified in table 6.1.3.13.3.1-3.

Table 6.1.3.13.3.1-2: Data structures supported by the PUT Request Body on this resource

Data type	P	Cardinality	Description
AcknowledgeInfo	M	1	Contains the SOR-MAC-lue received from the UE.

Table 6.1.3.13.3.1-3: Data structures supported by the PUT Response Body on this resource

Data type	P	Cardinality	Response codes	Description
n/a			204 No Content	Successful receiving the SorXmaclue in the Request.
ProblemDetails	M	1	404 Not Found	The "cause" attribute shall be set to the following application error: - USER_NOT_FOUND

NOTE: In addition common data structures as listed in table 6.1.7-1 are supported.

6.1.3.14 Resource: TraceData

6.1.3.14.1 Description

This resource represents the trace configuration data for a SUPI. It is queried by the AMF and SMF after registering.

6.1.3.14.2 Resource Definition

Resource URI: {apiRoot}/nudm-sdm/v1/{supi}/trace-data

This resource shall support the resource URI variables defined in table 6.1.3.14.2-1.

Table 6.1.3.14.2-1: Resource URI variables for this resource

Name	Definition
apiRoot	See subclause 6.1.1
supi	Represents the Subscription Permanent Identifier (see 3GPP TS 23.501 [2] clause 5.9.2) pattern: "(imsi-[0-9]{5,15} nai-.+ .+)")

6.1.3.14.3 Resource Standard Methods

6.1.3.14.3.1 GET

This method shall support the URI query parameters specified in table 6.1.3.14.3.1-1.

Table 6.1.3.14.3.1-1: URI query parameters supported by the GET method on this resource

Name	Data type	P	Cardinality	Description
supported-features	SupportedFeatures	O	0..1	see 3GPP TS 29.500 [4] subclause 6.6
plmn-id	PlmnId	O	0..1	PLMN identity of the PLMN serving the UE

If "plmn-id" is included, UDM shall return the Trace Data for the SUPI associated to the PLMN identified by "plmn-id".

If "plmn-id" is not included, UDM shall return the Trace Data for the SUPI associated to the HPLMN.

This method shall support the request data structures specified in table 6.1.3.14.3.1-2 and the response data structures and response codes specified in table 6.1.3.14.3.1-3.

Table 6.1.3.14.3.1-2: Data structures supported by the GET Request Body on this resource

Data type	P	Cardinality	Description
n/a			

Table 6.1.3.14.3.1-3: Data structures supported by the GET Response Body on this resource

Data type	P	Cardinality	Response codes	Description
TraceDataResponse	M	1	200 OK	Upon success, a response body containing the Trace Data shall be returned.
ProblemDetails	M	1	404 Not Found	The "cause" attribute shall be set to one of the following application errors: - USER_NOT_FOUND - DATA_NOT_FOUND
NOTE: In addition common data structures as listed in table 6.1.7-1 are supported.				

6.1.3.15 Resource: SharedData

6.1.3.15.1 Description

This resource represents the collection of data that can be shared by multiple UEs.

6.1.3.15.2 Resource Definition

Resource URI: {apiRoot}/nudm-sdm/v1/shared-data

This resource shall support the resource URI variables defined in table 6.1.3.15.2-1.

Table 6.1.3.15.2-1: Resource URI variables for this resource

Name	Definition
apiRoot	See subclause 6.1.1

6.1.3.15.3 Resource Standard Methods

6.1.3.15.3.1 GET

This method shall support the URI query parameters specified in table 6.1.3.15.3.1-1.

Table 6.1.3.15.3.1-1: URI query parameters supported by the GET method on this resource

Name	Data type	P	Cardinality	Description
shared-data-ids	array(SharedDataId)	M	1..N	

This method shall support the request data structures specified in table 6.1.3.15.3.1-2 and the response data structures and response codes specified in table 6.1.3.15.3.1-3.

Table 6.1.3.15.3.1-2: Data structures supported by the GET Request Body on this resource

Data type	P	Cardinality	Description
n/a			

Table 6.1.3.15.3.1-3: Data structures supported by the GET Response Body on this resource

Data type	P	Cardinality	Response codes	Description
array(SharedData)	M	1..N	200 OK	Upon success, a response body containing a list of SharedData shall be returned.
ProblemDetails	M	1	404 Not Found	The "cause" attribute shall be set to the following application error: - DATA_NOT_FOUND
NOTE: In addition common data structures as listed in table 6.1.7-1 are supported.				

6.1.3.16 Resource: SharedDataSubscriptions

6.1.3.16.1 Description

This resource is used to represent subscriptions to notifications for shared data.

6.1.3.16.2 Resource Definition

Resource URI: {apiRoot}/nudm-sdm/v1/shared-data-subscriptions

This resource shall support the resource URI variables defined in table 6.1.3.16.2-1.

Table 6.1.3.16.2-1: Resource URI variables for this resource

Name	Definition
apiRoot	See subclause 6.1.1

6.1.3.16.3 Resource Standard Methods

6.1.3.16.3.1 POST

This method shall support the URI query parameters specified in table 6.1.3.16.3.1-1.

Table 6.1.3.16.3.1-1: URI query parameters supported by the POST method on this resource

Name	Data type	P	Cardinality	Description
n/a				

This method shall support the request data structures specified in table 6.1.3.16.3.1-2 and the response data structures and response codes specified in table 6.1.3.16.3.1-3.

Table 6.1.3.16.3.1-2: Data structures supported by the POST Request Body on this resource

Data type	P	Cardinality	Description
SdmSubscription	M	1	The subscription that is to be created.

Table 6.1.3.16.3.1-3: Data structures supported by the POST Response Body on this resource

Data type	P	Cardinality	Response codes	Description
SdmSubscription	M	1	201 Created	Upon success, a response body containing a representation of the created Individual subscription resource shall be returned. The HTTP response shall include a "Location" HTTP header that contains the resource URI of the created resource. When stateless UDM is deployed, the stateless UDM shall use the FQDN identifying the UDM set to which the UDM belongs as the host part of the resource URI.
ProblemDetails	M	1	501 Not Implemented	The "cause" attribute shall be set to the following application error: - UNSUPPORTED_RESOURCE_URI

NOTE: In addition common data structures as listed in table 6.1.7-1 are supported.

NOTE: In the scenario of stateless UDM deployment, it is assumed that stateless UDMs are organized into several UDM sets, and each UDM set is allocated an FQDN.

6.1.3.17 Resource: Individual subscription

6.1.3.17.1 Description

This resource is used to represent an individual subscription to notifications for shared data.

6.1.3.17.2 Resource Definition

Resource URI: {apiRoot}/nudm-sdm/v1/shared-data-subscriptions/{subscriptionId}

This resource shall support the resource URI variables defined in table 6.1.3.17.2-1.

Table 6.1.3.17.2-1: Resource URI variables for this resource

Name	Definition
apiRoot	See subclause 6.1.1
subscriptionId	The subscriptionId identifies an individual subscription to notifications. The value is allocated by the UDM during creation of the Subscription resource.

6.1.3.17.3 Resource Standard Methods

6.1.3.17.3.1 DELETE

This method shall support the URI query parameters specified in table 6.1.3.17.3.1-1.

Table 6.1.3.17.3.1-1: URI query parameters supported by the DELETE method on this resource

Name	Data type	P	Cardinality	Description
n/a				

This method shall support the request data structures specified in table 6.1.3.17.3.1-2 and the response data structures and response codes specified in table 6.1.3.17.3.1-3.

Table 6.1.3.17.3.1-2: Data structures supported by the Delete Request Body on this resource

Data type	P	Cardinality	Description
n/a			The request body shall be empty.

Table 6.1.3.17.3.1-3: Data structures supported by the DELETE Response Body on this resource

Data type	P	Cardinality	Response codes	Description
n/a			204 No Content	Upon success, an empty response body shall be returned.

NOTE: In addition common data structures as listed in table 6.1.7-1 are supported.

6.1.3.18 Resource: UeContextInSmsfData

6.1.3.18.1 Description

This resource represents the allocated SMSFs for a SUPI.

6.1.3.18.2 Resource Definition

Resource URI: {apiRoot}/nudm-sdm/v1/{supi}/ue-context-in-smsf-data

This resource shall support the resource URI variables defined in table 6.1.3.18.2-1.

Table 6.1.3.18.2-1: Resource URI variables for this resource

Name	Definition
apiRoot	See subclause 6.1.1
supi	Represents the Subscription Permanent Identifier (see 3GPP TS 23.501 [2] clause 5.9.2) pattern: "(imsi-[0-9]{5,15} nai-.+ .+)"

6.1.3.18.3 Resource Standard Methods

6.1.3.18.3.1 GET

This method shall support the URI query parameters specified in table 6.1.3.18.3.1-1.

Table 6.1.3.18.3.1-1: URI query parameters supported by the GET method on this resource

Name	Data type	P	Cardinality	Description
supported-features	SupportedFeatures	O	0..1	see 3GPP TS 29.500 [4] subclause 6.6

This method shall support the request data structures specified in table 6.1.3.18.3.1-2 and the response data structures and response codes specified in table 6.1.3.18.3.1-3.

Table 6.1.3.18.3.1-2: Data structures supported by the GET Request Body on this resource

Data type	P	Cardinality	Description
n/a			

Table 6.1.3.18.3.1-3: Data structures supported by the GET Response Body on this resource

Data type	P	Cardinality	Response codes	Description
UeContextInSmsfData	M	1	200 OK	Upon success, a response body containing the UeContextInSmsfData shall be returned.
ProblemDetails	M	1	404 Not Found	The "cause" attribute shall be set to one of the following application errors: - USER_NOT_FOUND - DATA_NOT_FOUND

NOTE: In addition common data structures as listed in table 6.1.7-1 are supported.

6.1.4 Custom Operations without associated resources

In this release of this specification, no custom operations without associated resources are defined for the Nudm_SubscriberDataManagement Service.

6.1.5 Notifications

6.1.5.1 General

This subclause will specify the use of notifications and corresponding protocol details if required for the specific service. When notifications are supported by the API, it will include a reference to the general description of notifications support over the 5G SBIs specified in TS 29.500 / TS 29.501.

6.1.5.2 Data Change Notification

The POST method shall be used for Data Change Notifications and the URI shall be as provided during the subscription procedure.

Resource URI: {callbackReference}

Support of URI query parameters is specified in table 6.1.5.2-1.

Table 6.1.5.2-1: URI query parameters supported by the POST method

Name	Data type	P	Cardinality	Description
n/a				

Support of request data structures is specified in table 6.1.5.2-2 and of response data structures and response codes is specified in table 6.1.5.2-3.

Table 6.1.5.2-2: Data structures supported by the POST Request Body

Data type	P	Cardinality	Description
ModificationNotification	M	1	

Table 6.1.5.2-3: Data structures supported by the POST Response Body

Data type	P	Cardinality	Response codes	Description
n/a			204 No Content	Upon success, an empty response body shall be returned.
ProblemDetails	M	1	307 Temporary Redirect	This represents the case when the related UE context is not fully available at the target NF Service Consumer (e.g. AMF) during a planned maintenance case (e.g. AMF planned maintenance without UDSF case). The "cause" attribute shall be set to the following application error: - NF_CONSUMER_REDIRECT_ONE_TXN See table 6.1.7.3-1 for the description of this error. The Location header of the response shall be set to the new Callback URI of the target NF Service Consumer (e.g. AMF) to which the request is redirected.
ProblemDetails	M	1	308 Permanent Redirect	This represents the case when the related UE is not found in the NF Service Consumer (e.g. AMF) and the NF Service Consumer knows which NF Service Consumer is serving the UE. The "cause" attribute shall be set to the following application error: - CONTEXT_NOT_FOUND See table 6.1.7.3-1 for the description of this error. The Location header of the response shall be set to the new Callback URI of the target NF Service Consumer (e.g. AMF) to which the request is redirected.
ProblemDetails	M	1	404 Not Found	The "cause" attribute shall be set to the following application error: - CONTEXT_NOT_FOUND See table 6.1.7.3-1 for the description of this error.
NOTE: In addition common data structures as listed in table 6.1.7-1 are supported.				

6.1.6 Data Model

6.1.6.1 General

This subclause specifies the application data model supported by the API.

Table 6.1.6.1-1 specifies the structured data types defined for the Nudm_SDM service API. For simple data types defined for the Nudm_SDM service API see table 6.1.6.3.2-1.

Table 6.1.6.1-1: Nudm_SDM specific Data Types

Data type	Section defined	Description
Nssai	6.1.6.2.2	Network Slice Selection Assistance Information
SdmSubscription	6.1.6.2.3	A subscription to notifications
AccessAndMobilitySubscriptionData	6.1.6.2.4	Access and Mobility Subscription Data
SmfSelectionSubscriptionData	6.1.6.2.5	SMF Selection Subscription Data
UeContextInSmfData	6.1.6.2.16	UE Context In SMF Data
PduSession	6.1.6.2.17	
DnnInfo	6.1.6.2.6	Data Network Name and associated information (LBO roaming allowed flag)
SnsaiInfo	6.1.6.2.7	S-NSSAI and associated information (DNN Info)
SessionManagementSubscriptionData	6.1.6.2.8	User subscribed session management data
DnnConfiguration	6.1.6.2.9	User subscribed data network configuration
PduSessionTypes	6.1.6.2.11	Default/allowed session types for a data network
SscModes	6.1.6.2.12	Default/allowed SSC modes for a data network
SmsManagementSubscriptionData	6.1.6.2.14	SMS Management Subscription Data
IdTranslationResult	6.1.6.2.18	SUPI that corresponds to a given GPSI
IpAddress	6.1.6.2.22	IP address (IPv4, or IPv6, or IPv6 prefix)
3GppChargingCharacteristics	6.1.6.3.2	3GPP Charging Characteristics
lwkEpsInd	6.1.6.3.2	Interworking with EPS Indication
ModificationNotification	6.1.6.2.21	
UeContextInSmsfData	6.1.6.2.23	
SmsfInfo	6.1.6.2.24	
AcknowledgeInfo	6.1.6.2.25	
SorInfo	6.1.6.2.26	Steering Of Roaming Information
SharedData	6.1.6.2.27	Subscription Data shared by multiple UEs
PgwInfo	6.1.6.2.28	Information about the DNNs/APNs and PGW-C+SMF FQDNs used in interworking with EPS
TraceDataResponse	6.1.6.2.29	Contains Trace Data or a shared data Id identifying shared Trace Data

Table 6.1.6.1-2 specifies data types re-used by the Nudm_SDM service API from other specifications, including a reference to their respective specifications and when needed, a short description of their use within the Nudm_SDM service API.

Table 6.1.6.1-2: Nudm_SDM re-used Data Types

Data type	Reference	Comments
Dnn	3GPP TS 29.571 [7]	Data Network Name; this type is used as key in a map of DnnConfigurations; see subclause 6.1.6.2.8.
DurationSec	3GPP TS 29.571 [7]	Time value in seconds
ProblemDetails	3GPP TS 29.571 [7]	Common data type used in response bodies
Snssai	3GPP TS 29.571 [7]	Single NSSAI
Uri	3GPP TS 29.571 [7]	Uniform Resource Identifier
Gpsi	3GPP TS 29.571 [7]	Generic Public Subscription Identifier
RatType	3GPP TS 29.571 [7]	Radio Access Technology Type
Area	3GPP TS 29.571 [7]	
ServiceAreaRestriction	3GPP TS 29.571 [7]	
CoreNetworkType	3GPP TS 29.571 [7]	
SupportedFeatures	3GPP TS 29.571 [7]	see 3GPP TS 29.500 [4] subclause 6.6
PlmnId	3GPP TS 29.571 [7]	PLMN Identity
PduSessionType	3GPP TS 29.571 [7]	
SubscribedDefaultQos	3GPP TS 29.571 [7]	Subscribed Default QoS
Ambr	3GPP TS 29.571 [7]	
PduSessionId	3GPP TS 29.571 [7]	PduSessionId is used as key in a map of PduSessions; see subclause 6.1.6.2.16.
NfInstanceId	3GPP TS 29.571 [7]	
Supi	3GPP TS 29.571 [7]	
RfspIndex	3GPP TS 29.571 [7]	
SscMode	3GPP TS 29.571 [7]	
Ipv4Address	3GPP TS 29.571 [7]	
Ipv6Address	3GPP TS 29.571 [7]	
Ipv6Prefix	3GPP TS 29.571 [7]	
SorMac	3GPP TS 29.509 [24]	
SteeringInfo	3GPP TS 29.509 [24]	
AckInd	3GPP TS 29.509 [24]	
CounterSor	3GPP TS 29.509 [24]	
TraceData	3GPP TS 29.571 [7]	Trace control and configuration parameters
NotifyItem	3GPP TS 29.571 [7]	
UpSecurity	3GPP TS 29.571 [7]	
ServiceName	3GPP TS 29.510 [19]	
OdbPacketServices	3GPP TS 29.571 [7]	

6.1.6.2 Structured data types

6.1.6.2.1 Introduction

This subclause defines the structures to be used in resource representations.

6.1.6.2.2 Type: Nssai

Table 6.1.6.2.2-1: Definition of type Nssai

Attribute name	Data type	P	Cardinality	Description
supportedFeatures	SupportedFeatures	O	0..1	See subclause 6.1.8
defaultSingleNssais	array(Snssai)	M	1..N	A list of Single Nssai used as default
singleNssais	array(Snssai)	O	1..N	A list of Single Nssai

6.1.6.2.3 Type: SdmSubscription

Table 6.1.6.2.3-1: SdmSubscription

Attribute name	Data type	P	Cardinality	Description
nfnstanceld	Nfnstanceld	M	1	Identity of the NF Instance creating the subscription.
implicitUnsubscribe	boolean	O	0..1	If present with value true indicates that the subscription expires when the subscribing NF (AMF, SMF, SMSF) identified by the nfnstanceld ceases to be registered at the UDM.
expires	DateTime	C	0..1	If present, indicates the point in time at which the subscription expires. Shall be present if implicitUnsubscribe is absent or false. Within a POST request the proposed expiry time is conveyed whereas in a POST response the confirmed expiry time is returned.
callbackReference	Uri	M	1	URI provided by the NF service consumer to receive notifications
amfServiceNameDataChange	ServiceName	O	0..1	When present, this IE shall contain the name of the AMF service to which Data Change Notifications are to be sent (see see subclause 6.5.2.2 of 3GPP TS 29.500 [4]). This IE may be included if the NF service consumer is an AMF.
monitoredResourceUris	array(Uri)	M	1..N	A set of URIs that identify the resources for which a change triggers a notification
singleNssai	Snssai	O	0..1	This IE may be present if the consumer is SMF. See NOTE.
dnn	Dnn	O	0..1	This IE may be present if the consumer is SMF. See NOTE.
NOTE:	<p>If "singleNssai" is not included, and "dnn" is not included, the UDM shall notify the data change of all DNN configurations and network slice(s).</p> <p>If "singleNssai" is included, and "dnn" is not included, the UDM shall notify the data change of network slice identified by "singleNssai" and all DNN configurations for the requested network slice identified by "singleNssai".</p> <p>If "singleNssai" is not included, and "dnn" is included, the UDM shall notify the data change of all network slices where such DNN is available and all DNN configurations identified by "dnn".</p> <p>If "singleNssai" is included, and "dnn" is included, the UDM shall notify the data change of network slice identified by "singleNssai" where such DNN is available and the DNN configuration identified by "dnn", if such DNN is available in the network slice identified by "singleNssai".</p>			

6.1.6.2.4 Type: AccessAndMobilitySubscriptionData

Table 6.1.6.2.4-1: Definition of type AccessAndMobilitySubscriptionData

Attribute name	Data type	P	Cardinality	Description
supportedFeatures	SupportedFeatures	O	0..1	See subclause 6.1.8
gpsis	array(Gpsi)	O	0..N	List of Generic Public Subscription Identifier; see 3GPP TS 29.571 [7]
internalGroupIds	array(GroupId)	O	1..N	List of internal group identifier; see 3GPP TS 23.501 [2] subclause 5.9.7
subscribedUeAmbr	AmbrRm	O	0..1	
nssai	Nssai	O	0..1	Network Slice Selection Assistance Information
ratRestrictions	array(RatType)	O	0..N	List of RAT Types that are restricted; see 3GPP TS 29.571 [7]
forbiddenAreas	array(Area)	O	0..N	List of forbidden areas
serviceAreaRestriction	ServiceAreaRestriction	O	0..1	Subscribed Service Area Restriction
coreNetworkTypeRestrictions	array(CoreNetworkType)	O	0..N	List of Core Network Types that are restricted
rfspIndex	RfspIndexRm	O	0..1	Index to RAT/Frequency Selection Priority;
subsRegTimer	DurationSecRm	O	0..1	Subscribed periodic registration timer; see 3GPP TS 29.571 [7]
ueUsageType	UeUsageType	O	0..1	
mpsPriority	MpsPriorityIndicator	O	0..1	
mcsPriority	McsPriorityIndicator	O	0..1	
activeTime	DurationSecRm	O	0..1	subscribed active time for PSM UEs
dlPacketCount	DlPacketCount	O	0..1	DL Buffering Suggested Packet Count indicates whether extended buffering of downlink packets for High Latency Communication is requested.
sorInfo	SorInfo	O	0..1	This IE shall be present if the UDM shall send the information for Steering of Roaming during registration or the subscription data update to the UE.
micoAllowed	MicoAllowed	O	0..1	Indicates whether the UE subscription allows MICO mode.
sharedAmDataIds	array(SharedDataId)	O	0..N	Identifier of shared Access And Mobility Subscription data
odbPacketServices	OdbPacketServices	O	0..1	Operator Determined Barring for Packet Oriented Services
<p>NOTE: AccessAndMobilitySubscriptionData can be UE-individual data or shared data. UE-individual data take precedence over shared data. E.g.: When an attribute of type array is present but empty within UE-Individual data and present (with any cardinality) in shared data, the empty array takes precedence. Similarly, when a nullable attribute is present with value null within the individual data and present (with any value) in shared data, the null value takes precedence (i.e. for the concerned UE the attribute is considered absent).</p>				

6.1.6.2.5 Type: SmfSelectionSubscriptionData

Table 6.1.6.2.5-1: Definition of type SmfSelectionSubscriptionData

Attribute name	Data type	P	Cardinality	Description
supportedFeatures	SupportedFeatures	O	0..1	See subclause 6.1.8
subscribedSnssaiInfos	map(SnssaiInfo)	O	0..N	List of S-NSSAIs and associated information (DNN Info); see 3GPP TS 23.501 [2] clause 6.3.2. A map (list of key-value pairs where singleNssai converted to string serves as key; see 3GPP TS 29.571 [7]) of arrays of DnnInfo
sharedSnssaiInfosId	SharedDataId	O	0..1	Identifier of shared SnssaiInfos.
NOTE: A single UE-individual subscribedSnssaiInfo (within subscribedSnssaiInfos) may clash with a sharedSnssaiInfo (i.e. both have the same singleNssai value as key). In this case the UE-individual subscribedSnssaiInfo takes precedence.				

6.1.6.2.6 Type: DnnInfo

Table 6.1.6.2.6-1: Definition of type DnnInfo

Attribute name	Data type	P	Cardinality	Description
dnn	Dnn	M	1	Data Network Name
defaultDnnIndicator	DefaultDnnIndicator	O	0..1	Indicates whether this DNN is the default DNN: true: The DNN is the default DNN; false: The DNN is not the default DNN; If this attribute is absent it means the DNN is not the default DNN.
lboRoamingAllowed	LboRoamingAllowed	O	0..1	Indicates whether local breakout for the DNN is allowed when roaming: true: Allowed; false: Not allowed; If this attribute is absent it means not allowed.
iwkEpsInd	IwkEpsInd	O	0..1	Indicates whether interworking with EPS is subscribed: true: Subscribed; false: Not subscribed; If this attribute is absent it means not subscribed.
ladnIndicator	LadnIndicator	O	0..1	Indicates whether the DNN is a local area data network. If this attribute is absent, it means that the DNN is not a local area data network.

6.1.6.2.7 Type: SnssaiInfo

Table 6.1.6.2.7-1: Definition of type SnssaiInfo

Attribute name	Data type	P	Cardinality	Description
dnnInfos	array(DnnInfo)	M	1..N	list of Data Network Names for an S-NSSAI and associated information

6.1.6.2.8 Type: SessionManagementSubscriptionData

Table 6.1.6.2.8-1: SessionManagementSubscriptionData

Attribute name	Data type	P	Cardinality	Description
singleNssai	Snssai	M	1	A single Network Slice Selection Assistance Information
dnnConfigurations	map(DnnConfiguration)	O	0..N	Additional DNN configurations for the network slice; A map (list of key-value pairs where dnn serves as key; see subclause 6.1.6.1) of DnnConfigurations.
internalGroupIds	array(GroupId)	O	1..N	List of internal group identifier; see 3GPP TS 23.501 [2] subclause 5.9.7
sharedDnnConfigurationSld	SharedDataId	O	1..0	Identifier of shared data.
NOTE: A single UE-individual dnnConfiguration (within dnnConfigurations) may clash with a shared dnnConfiguration (i.e. both have the same dnn value as key). In this case the UE-individual dnnConfiguration takes precedence.				

6.1.6.2.9 Type: DnnConfiguration

Table 6.1.6.2.9-1: DnnConfiguration

Attribute name	Data type	P	Cardinality	Description
pduSessionTypes	PduSessionTypes	M	1	Default/Allowed session types
sscModes	SscModes	M	1	Default/Allowed SSC modes
iwkEpsInd	IwkEpsInd	O	0..1	Indicates whether interworking with EPS is subscribed: true: Subscribed; false: Not subscribed; If this attribute is absent it means not subscribed.
ladnIndicator	LadnIndicator	O	0..1	Indicates whether the DNN is a local area data network
5gQosProfile	SubscribedDefaultQos	O	0..1	5G QoS parameters associated to the session for a data network
sessionAmbr	Ambr	O	0..1	The maximum aggregated uplink and downlink bit rates to be shared across all Non-GBR QoS Flows in each PDU Session
3gppChargingCharacteristics	3GppChargingCharacteristics	O	0..1	Subscribed charging characteristics data associated to the session for a data network
staticIpAddress	array(IpAddress)	O	1..2	Subscribed static IP address(es) of the IPv4 and/or IPv6 type
upSecurity	UpSecurity	O	0..1	When present, this IE shall indicate the security policy for integrity protection and encryption for the user plane.

6.1.6.2.10 Void

6.1.6.2.11 Type: PduSessionTypes

Table 6.1.6.2.11-1: PduSessionTypes

Attribute name	Data type	P	Cardinality	Description
defaultSessionType	PduSessionType	M	1	Default session type
allowedSessionTypes	array(PduSessionType)	O	1..N	Additional session types allowed for the data network

6.1.6.2.12 Type: SscModes

Table 6.1.6.2.12-1: SscModes

Attribute name	Data type	P	Cardinality	Description
defaultSscMode	SscMode	M	1	Default SSC mode
allowedSscModes	array(SscMode)	O	1..2	Additional SSC modes allowed for the data network

6.1.6.2.13 Type: SmsSubscriptionData

Table 6.1.6.2.13-1: Definition of type SmsSubscriptionData

Attribute name	Data type	P	Cardinality	Description
smsSubscribed	SmsSubscribed	C	0..1	Indicates whether the UE subscription allows SMS delivery over NAS. Shall not be absent unless the feature SharedData is supported and smsSubscribed is present within shared data.
sharedSmsSubsDataId	SharedDataId	C	0..1	Identifier of shared data. Shall be present if smsSubscribed is absent.

6.1.6.2.14 Type: SmsManagementSubscriptionData

Table 6.1.6.2.14-1: Definition of type SmsManagementSubscriptionData

Attribute name	Data type	P	Cardinality	Description
supportedFeatures	SupportedFeatures	O	0..1	See subclause 6.1.8
mtSmsSubscribed	boolean	C	1	Indicates the SMS teleservice subscription for MT-SMS. Shall not be absent unless the feature SharedData is supported and mtSmsSubscribed is present within shared data.
mtSmsBarringAll	boolean	C	0..1	Barring of all incoming calls for MT-SMS
mtSmsBarringRoaming	boolean	C	0..1	Barring of incoming calls for MT-SMS when roaming outside the Home Public Land Mobile Network (PLMN) country
moSmsSubscribed	boolean	C	1	Indicates the SMS teleservice subscription for MO-SMS. Shall not be absent unless the feature SharedData is supported and mtSmsSubscribed is present within shared data.
moSmsBarringAll	boolean	C	0..1	Barring of all outgoing calls for MO-SMS
moSmsbarringRoaming	boolean	C	0..1	Barring of outgoing calls for MO-SMS when roaming outside the Home Public Land Mobile Network (PLMN) country
sharedSmsMngDataIds	array(SharedDataId)	C	1..N	Identifier of shared data. Shall be present if mtSmsSubscribed and/or moSmsSubscribed are absent.

6.1.6.2.15 Type: SubscriptionDataSets

Table 6.1.6.2.15-1: SubscriptionDataSets

Attribute name	Data type	P	Cardinality	Description
amData	AccessAndMobilitySubscriptionData	O	0..1	Access and Mobility Subscription Data
smfSelData	SmfSelectionSubscriptionData	O	0..1	SMF Selection Subscription Data
uecSmfData	UeContextInSmfData	O	0..1	UE Context In SMF Data
uecSmsfData	UeContextInSmsfData	O	0..1	UE Context In SMSF Data
smsSubsData	SmsSubscriptionData	O	0..1	SMS Subscription Data
smData	array(SessionmanagementsubscriptionData)	O	1..N	Session Management Subscription Data
traceData	TraceData	O	0..1	Trace Data. The Null value indicates that trace is not active.
smsMngData	SmsManagementSubscriptionData	O	0..1	SMS Management Subscription Data

6.1.6.2.16 Type: UeContextInSmfData

Table 6.1.6.2.16-1: Definition of type UeContextInSmfData

Attribute name	Data type	P	Cardinality	Description
pduSessions	map(PduSession)	O	0..N	A map (list of key-value pairs where pduSessionId converted from integer to string serves as key; see subclause 6.1.6.1) of PduSessions.
pgwInfo	array(PgwInfo)	O	1..N	Information about the DNNs/APNs and PGW-C+SMF FQDNs used in interworking with EPS

6.1.6.2.17 Type: PduSession

Table 6.1.6.2.17-1: Definition of type PduSession

Attribute name	Data type	P	Cardinality	Description
dnn	Dnn	M	1	Data Network Name
smfInstanceld	NfInstanceld	M	1	NF Instance Id of the SMF
plmnld	Plmnld	M	1	PLMN Id of the SMF

6.1.6.2.18 Type: IdTranslationResult

Table 6.1.6.2.18-1: Definition of type IdTranslationResult

Attribute name	Data type	P	Cardinality	Description
supportedFeatures	SupportedFeatures	O	0..1	See subclause 6.1.8
supi	Supi	M	1	SUPI
gpsi	Gpsi	O	0..1	shall be an MSISDN

6.1.6.2.19 Void

6.1.6.2.20 Void

6.1.6.2.21 Type: ModificationNotification

Table 6.1.6.2.21-1: ModificationNotification

Attribute name	Data type	P	Cardinality	Description
notifyItems	array(NotifyItem)	M	1..N	

6.1.6.2.22 Type: IpAddress

Table 6.1.6.2.22-1: IpAddress

Attribute name	Data type	P	Cardinality	Description
ipv4Addr	Ipv4Addr	C	0..1	
ipv6Addr	Ipv6Addr	C	0..1	
ipv6Prefix	Ipv6Prefix	C	0..1	
NOTE: Either ipv4Addr, or ipv6Addr, or ipv6Prefix shall be present.				

6.1.6.2.23 Type: UeContextInSmsfData

Table 6.1.6.2.23-1: Definition of type UeContextInSmsfData

Attribute name	Data type	P	Cardinality	Description
smsfInfo3GppAccess	SmsfInfo	O	0..1	SMSF Info for 3GPP Access
smsfInfoNon3GppAccess	SmsfInfo	O	0..1	SMSF Info for Non 3GPP Access

6.1.6.2.24 Type: SmsfInfo

Table 6.1.6.2.24-1: Definition of type SmsfInfo

Attribute name	Data type	P	Cardinality	Description
smsfInstanceld	NfInstanceld	M	1	NF Instance Id of the SMSF
plmnld	Plmnld	M	1	PLMN Id of the SMSF

6.1.6.2.25 Type: AcknowledgeInfo

Table 6.1.6.2.25: Definition of type AcknowledgeInfo

Attribute name	Data type	P	Cardinality	Description
sorMaclue	SorMac	C	0..1	Shall be present when the Acknowledgement is sent to acknowledge receipt of SorInfo.
securedPacket	SecuredPacket	C	0..1	Shall be present when the Acknowledgement is sent to acknowledge receipt of a SecuredPacket.

6.1.6.2.26 Type: SorInfo

Table 6.1.6.2.26: Definition of type SorInfo

Attribute name	Data type	P	Cardinality	Description
ackInd	AckInd	M	1	Contains the indication whether the acknowledgement from UE is needed.
sorMaclausf	SorMac	M	1	Contains the SoR-MAC-IAUSF.
countersor	CounterSor	M	1	Contains the CounterSoR.
steeringContainer	SteeringContainer	C	1	When present, this information contains the information needed to update the "Operator Controlled PLMN Selector with Access Technology" list stored in the USIM either as an array of preferred PLMN/AccessTechnologies combinations in priority order. The first entry in the array indicates the highest priority and the last entry indicates the lowest. Or it may contain a secured packet. If no change of the "Operator Controlled PLMN Selector with Access Technology" list stored in the USIM is needed, then this attribute shall be absent.

6.1.6.2.27 Type: SharedData

Table 6.1.6.2.27-1: SharedData

Attribute name	Data type	P	Cardinality	Description
sharedDataId	SharedDataId	M	1	Identifier of the shared data
sharedAmData	AccessAndMobilitySubscriptionData	O	0..1	Shared Access and Mobility Subscription Data
sharedSmsSubsData	SmsSubscriptionData	O	0..1	Shared SMS Subscription Data
sharedSmsMngSubsData	SmsManagementSubscriptionData	O	0..1	Shared SMS Management Subscription Data
sharedDnnConfigurations	map(DnnConfigurations)	O	1..N	Shared DNN configurations
sharedTraceData	TraceData	O	0..1	Shared Trace Data
sharedSnssaiInfos	map(SnssaiInfo)	O	1..N	Shared Snssai Infos
sharedAuthenticationSubscription	SharedAuthenticationSubscription	O	0..1	Shared Authentication Subscription (see Note 4).
Note 1:	Exactly one of sharedAmData, sharedSmsSubsData, sharedSmsMngSubsData, sharedDnnConfigurations, sharedTraceData and sharedSnssaiInfos shall be present.			
Note 2:	The attributes sharedAmData, sharedSmsSubsData and sharedSmsMngSubsData shall not contain sharedDataId			
Note 3:	When shared data clash with individual data, individual data shall take precedence.			
Note 4:	The Shared Authentication Subscription shall only be exposed over the Nudr SBI.			

6.1.6.2.28 Type: PgwInfo

Table 6.1.6.2.28-1: PgwInfo

Attribute name	Data type	P	Cardinality	Description
dnn	Dnn	M	1	DNN/APN
pgwFqdn	string	M	1	FQDN of the PGW-C+SMF
plmnId	PlmnId	O	0..1	PLMN where the PGW-C+SMF is located

6.1.6.2.29 Type: TraceDataResponse

Table 6.1.6.2.29-1: TraceDataResponse

Attribute name	Data type	P	Cardinality	Description
traceData	TraceData	C	0..1	UE-individual trace data. Shall not be absent unless the feature SharedData is supported and traceData is present within shared data.
sharedTraceDataId	SharedDataId	C	0..1	Shared data identifier. Shall be present if traceData is absent.

6.1.6.2.30 Type: SteeringContainer

Table 6.1.6.2.30-1: Definition of type SteeringContainer as a list of alternatives

Data type	Cardinality	Description
array(SteeringInfo)	1..N	List of PLMN/AccessTechnologies combinations.
SecuredPacket	1	A Secured packet containing one or more APDUs commands dedicated to Remote File Management or command responses (see ETSI TS 102.225 [28]).

6.1.6.3 Simple data types and enumerations

6.1.6.3.1 Introduction

This subclause defines simple data types and enumerations that can be referenced from data structures defined in the previous subclauses.

6.1.6.3.2 Simple data types

The simple data types defined in table 6.1.6.3.2-1 shall be supported.

Table 6.1.6.3.2-1: Simple data types

Type Name	Type Definition	Description
DefaultDnnIndicator	boolean	Indicates whether a DNN is the default DNN
LadnIndicator	boolean	Indicates whether the DNN is a local area data network
LboRoamingAllowed	boolean	This flag indicates whether local breakout is allowed when roaming.
UeUsageType	integer	Indicates the usage characteristics of the UE, enables the selection of a specific Dedicated Core Network for EPS interworking
MpsPriorityIndicator	boolean	Indicates whether UE is subscribed to multimedia priority service
McsPriorityIndicator	boolean	Indicates whether UE is subscribed to mission critical service
3GppChargingCharacteristics	string	16-bit string identifying charging characteristics as specified in 3GPP TS 32.251 [11] Annex A and 3GPP TS 32.298 [12] section 5.1.2.2.7, in hexadecimal representation. Each character in the string shall take a value of "0" to "9" or "A" to "F" and shall represent 4 bits. The most significant character representing the 4 most significant bits of the charging characteristics shall appear first in the string, and the character representing the 4 least significant bits of the charging characteristics shall appear last in the string. Example: The charging characteristic 0x123A shall be encoded as "123A".
DIPacketCount	integer	The following values are defined: 0: "Extended DL Data Buffering NOT REQUESTED" -1: "Extended DL Data Buffering REQUESTED, without a suggested number of packets" n>0: "Extended DL Data Buffering REQUESTED, with a suggested number of n packets"
InternalGroupId	GroupId	See 3GPP TS 23.003 [8] subclause 28.x
MicoAllowed	boolean	Indicates whether MICO mode is allowed for the UE.
SmsSubscribed	boolean	Indicates whether the UE subscription allows SMS delivery over NAS.
SharedDataId	string	Identifies globally and uniquely a piece of subscription data shared by multiple UEs. The value shall start with the HPLMN id (MCC/MNC) followed by a hyphen followed by a local Id as allocated by the home network operator. pattern: "[0-9]{5,6}-.+"
IwkEpsInd	boolean	Indicates whether Interworking with EPS is supported
SecuredPacket	string	Indicates the secured packet as specified in 3GPP TS 24.501 [27]. It is encoded using base64 and represented as a String.

6.1.6.3.3 Enumeration: DataSetName

Table 6.1.6.3.3-1: Enumeration DataSetName

Enumeration value	Description
"AM"	Access and Mobility Subscription Data
"SMF_SEL"	SMF Selection Subscription Data
"UEC_SMF"	UE Context in SMF Data
"UEC_SMSF"	UE Context in SMSF Data
"SMS_SUB"	SMS Subscription Data
"SM"	Session Management Subscription Data
"TRACE"	Trace Data
"SMS_MNG"	SMS Management Subscription Data

Editor's Note: The current naming conventions for Enumerations (uppercase with underscore), when their intended usage is for query parameters is not consistent with the naming conventions for URI components (lowercase with hyphen).

6.1.6.3.4 Void

6.1.6.3.5 Void

6.1.6.3.6 Void

6.1.7 Error Handling

6.1.7.1 General

HTTP error handling shall be supported as specified in subclause 5.2.4 of 3GPP TS 29.500 [4].

6.1.7.2 Protocol Errors

Protocol errors handling shall be supported as specified in subclause 5.2.7 of 3GPP TS 29.500 [4].

6.1.7.3 Application Errors

The common application errors defined in the Table 5.2.7.2-1 in 3GPP TS 29.500 [4] may also be used for the Nudm_SubscriberDataManagement service. The following application errors listed in Table 6.1.7.3-1 are specific for the Nudm_SubscriberDataManagement service.

Table 6.1.7.3-1: Application errors

Application Error	HTTP status code	Description
NF_CONSUMER_REDIRECT_ONE_TXN	307 Temporary Redirect	The request has been asked to be redirected to a specified target for one transaction.
CONTEXT_NOT_FOUND	308 Permanent Redirect	The request has been asked to be redirected to a specified target.
UE_DATA_NOT_FOUND	404 Not Found	The requested UE subscription data is not found/does not exist. This error is applicable to all Nudm_SDM GET operations.
USER NOT FOUND	404 Not Found	The user does not exist This error is applicable to all Nudm_SDM GET operations.
CONTEXT_NOT_FOUND	404 Not Found	It is used during the modification of an existing subscription when no corresponding context exists.
UNSUPPORTED_RESOURCE_URI	501 Not Implemented	The SDM Subscription contains unsupported resource URI to be monitored.

6.1.8 Feature Negotiation

The optional features in table 6.1.8-1 are defined for the Nudm_SDM API. They shall be negotiated using the extensibility mechanism defined in subclause 6.6 of 3GPP TS 29.500 [4].

Table 6.1.8-1: Supported Features

Feature number	Feature Name	Description
1	SharedData	When receiving a Nudm_SDM_Get service operation request to retrieve a UE's individual subscription data, and the request does not contain a supported-features query parameter indicating support of this feature, the UDM shall not include Shared Data Ids in the response. Instead the UDM may – based on operator policy – take no further action (i.e. allow the UE to get services based on only the UE's individual subscription data), or send the shared data as individual data (this may result in notifications of individual subscription data change – if so subscribed – when shared data, which are sent as individual data, are modified, and/or when the UE's Shared Data IDs are modified).

6.1.9 Security

As indicated in 3GPP TS 33.501 [6] and 3GPP TS 29.500 [4], the access to the Nudm_SDM API may be authorized by means of the OAuth2 protocol (see IETF RFC 6749 [18]), based on local configuration, using the "Client Credentials" authorization grant, where the NRF (see 3GPP TS 29.510 [19]) plays the role of the authorization server.

If OAuth2 is used, an NF Service Consumer, prior to consuming services offered by the Nudm_SDM API, shall obtain a "token" from the authorization server, by invoking the Access Token Request service, as described in 3GPP TS 29.510 [19], subclause 5.4.2.2.

NOTE: When multiple NRFs are deployed in a network, the NRF used as authorization server is the same NRF that the NF Service Consumer used for discovering the Nudm_SDM service.

The Nudm_SDM API defines a single scope "nudm-sdm" for OAuth2 authorization (as specified in 3GPP TS 33.501 [6]) for the entire API, and it does not define any additional scopes at resource or operation level.

6.2 Nudm_UEContextManagement Service API

6.2.1 API URI

URIs of this API shall have the following root:

```
{apiRoot}/{apiName}/{apiVersion}/
```

where "apiRoot" is defined in subclause 4.4.1 of 3GPP TS 29.501 [5], the "apiName" shall be set to "nudm-uecm" and the "apiVersion" shall be set to "v1" for the current version of this specification.

6.2.2 Usage of HTTP

6.2.2.1 General

HTTP/2, as defined in IETF RFC 7540 [13], shall be used as specified in clause 5 of 3GPP TS 29.500 [4].

HTTP/2 shall be transported as specified in subclause 5.3 of 3GPP TS 29.500 [4].

HTTP messages and bodies for the Nudm_UECM service shall comply with the OpenAPI [14] specification contained in Annex A3.

6.2.2.2 HTTP standard headers

6.2.2.2.1 General

The usage of HTTP standard headers shall be supported as specified in subclause 5.2.2 of 3GPP TS 29.500 [4].

6.2.2.2.2 Content type

The following content types shall be supported:

JSON, as defined in IETF RFC 8259 [15], signalled by the content type "application/json".

The Problem Details JSON Object (IETF RFC 7807 [16] signalled by the content type "application/problem+json"

JSON Merge Patch, as defined in IETF RFC 7396 [17], signalled by the content type "application/merge-patch+json"

6.2.2.3 HTTP custom headers

6.2.2.3.1 General

The usage of HTTP custom headers shall be supported as specified in subclause 5.2.3 of 3GPP TS 29.500 [4].

6.2.3 Resources

6.2.3.1 Overview

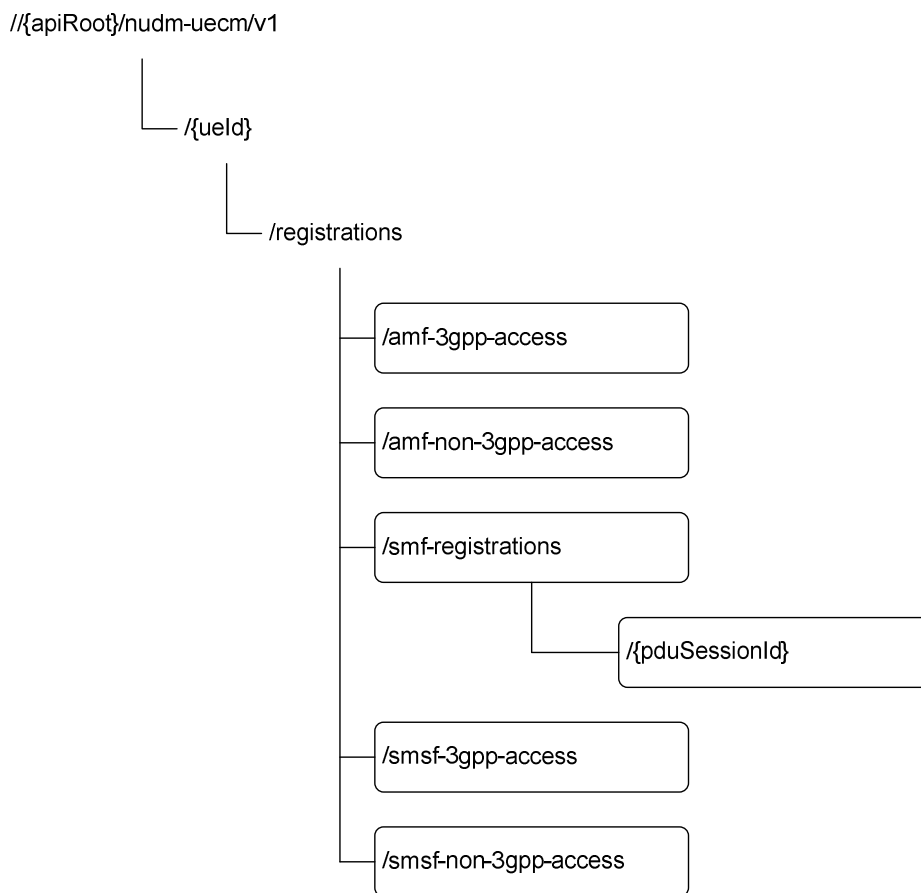

Figure 6.2.3.1-1: Resource URI structure of the Nudm_UECM API

Table 6.2.3.1-1 provides an overview of the resources and applicable HTTP methods.

Table 6.2.3.1-1: Resources and methods overview

Resource name (Archetype)	Resource URI	HTTP method or custom operation	Description
Amf3GppAccessRegistration (Document)	/{ueld}/registrations/amf-3gpp-access	PUT	Update the AMF registration for 3GPP access
		PATCH	Modify the AMF registration for 3GPP access
		GET	Retrieve the AMF registration information for 3GPP access
AmfNon3GppAccessRegistration (Document)	/{ueld}/registrations/amf-non-3gpp-access	PUT	Update the AMF registration for non 3GPP access
		PATCH	Modify the AMF registration for non 3GPP access
		GET	Retrieve the AMF registration information for non 3GPP access
SmfRegistrations (Store)	/{ueld}/registrations/smf-registrations		
IndividualSmfRegistration (Document)	/{ueld}/registrations/smf-registrations/{pduSessionId}	PUT	Create an SMF registration identified by PDU Session Id
		DELETE	Delete an individual SMF registration
		PATCH	Modify an individual SMF Registration
Smsf3GppAccessRegistration (Document)	/{ueld}/registrations/smsf-3gpp-access	PUT	Create or Update the SMSF registration
		DELETE	Delete the SMSF registration for 3GPP access
		PATCH	Modify the SMSF registration
SmsfNon3GppAccessRegistration (Document)	/{ueld}/registrations/smsf-non-3gpp-access	GET	Retrieve the SMSF registration information
		PUT	Create or Update the SMSF registration for non 3GPP access
		DELETE	Delete the SMSF registration for non 3GPP access
		PATCH	Modify the SMSF registration for non 3GPP access
		GET	Retrieve the SMSF registration information for non 3GPP access

6.2.3.2 Resource: Amf3GppAccessRegistration

6.2.3.2.1 Description

This resource represents the registered AMF for 3GPP access.

6.2.3.2.2 Resource Definition

Resource URI: {apiRoot}/nudm-uecm/v1/{ueId}/registrations/amf-3gpp-access

This resource shall support the resource URI variables defined in table 6.2.3.2.2-1.

Table 6.2.3.2.2-1: Resource URI variables for this resource

Name	Definition
apiRoot	See subclause 6.2.1
ueld	Represents the Subscription Identifier SUPI or GPSI (see 3GPP TS 23.501 [2] clause 5.9.2) SUPI (i.e. imsi or nai) is used with the PUT and PATCH methods; GPSI (i.e. msisdn or extid) is used with the GET method. pattern: "(imsi-[0-9]{5,15} nai-.+ msisdn-[0-9]{5,15} extid-[^@]+@[^@]+.+)"

6.2.3.2.3 Resource Standard Methods

6.2.3.2.3.1 PUT

This method shall support the URI query parameters specified in table 6.2.3.2.3.1-1.

Table 6.2.3.2.3.1-1: URI query parameters supported by the PUT method on this resource

Name	Data type	P	Cardinality	Description
n/a				

This method shall support the request data structures specified in table 6.2.3.2.3.1-2 and the response data structures and response codes specified in table 6.2.3.2.3.1-3.

Table 6.2.3.2.3.1-2: Data structures supported by the PUT Request Body on this resource

Data type	P	Cardinality	Description
Amf3GppAccess Registration	M	1	The AMF registration for 3GPP access is replaced with the received information.

Table 6.2.3.2.3.1-3: Data structures supported by the PUT Response Body on this resource

Data type	P	Cardinality	Response codes	Description
Amf3GppAccess Registration	M	1	201 Created	Upon success, a response body containing a representation of the created Individual Amf3GppAccessRegistration resource shall be returned.
Amf3GppAccess Registration	M	1	200 OK	Upon success, a response body containing a representation of the updated Individual Amf3GppAccessRegistration resource shall be returned.
n/a			204 No Content	Upon success, an empty response body shall be returned
ProblemDetails	M	1	404 Not Found	The "cause" attribute shall be set to the following application error: - USER_NOT_FOUND
ProblemDetails	M	1	403 Forbidden	The "cause" attribute shall be set to one of the following application errors: - UNKNOWN_5GS_SUBSCRIPTION - NO_PS_SUBSCRIPTION - ROAMING_NOT_ALLOWED - ACCESS_NOT_ALLOWED - RAT_NOT_ALLOWED - REAUTHENTICATION_REQUIRED

NOTE: In addition common data structures as listed in table 6.2.7-1 are supported.

6.2.3.2.3.2 PATCH

This method shall support the URI query parameters specified in table 6.2.3.2.3.2-1.

Table 6.2.3.2.3.2-1: URI query parameters supported by the PATCH method on this resource

Name	Data type	P	Cardinality	Description
n/a				

This method shall support the request data structures specified in table 6.2.3.2.3.2-2 and the response data structures and response codes specified in table 6.2.3.2.3.2-3.

Table 6.2.3.2.3.2-2: Data structures supported by the PATCH Request Body on this resource

Data type	P	Cardinality	Description
Amf3GppAccessRegistrationModification	M	1	The AMF registration for 3GPP access is modified with the received information.

Table 6.2.3.2.3.2-3: Data structures supported by the PATCH Response Body on this resource

Data type	P	Cardinality	Response codes	Description
n/a			204 No Content	Upon success, an empty response body shall be returned
ProblemDetails	M	1	404 Not Found	The "cause" attribute shall be set to one of the following application errors: - CONTEXT_NOT_FOUND - USER_NOT_FOUND
ProblemDetails	M	1	422 Unprocessable Entity	The "cause" attribute shall be set to the following application error: - UNPROCESSABLE_REQUEST

NOTE: In addition common data structures as listed in table 6.2.7-1 are supported.

6.2.3.2.3.3 GET

This method shall support the URI query parameters specified in table 6.2.3.2.3.3-1.

Table 6.2.3.2.3.3-1: URI query parameters supported by the GET method on this resource

Name	Data type	P	Cardinality	Description
supported-features	SupportedFeatures	O	0..1	see 3GPP TS 29.500 [4] subclause 6.6

This method shall support the request data structures specified in table 6.2.3.2.3.3-2 and the response data structures and response codes specified in table 6.2.3.2.3.3-3.

Table 6.2.3.2.3.3-2: Data structures supported by the GET Request Body on this resource

Data type	P	Cardinality	Description
n/a			

Table 6.2.3.2.3.3-3: Data structures supported by the GET Response Body on this resource

Data type	P	Cardinality	Response codes	Description
Amf3GppAccessRegistration	M	1	200 OK	Upon success, a response body containing the Amf3GppAccessRegistration shall be returned.
ProblemDetails	M	1	404 Not Found	The "cause" attribute shall be set to one of the following application errors: - CONTEXT_NOT_FOUND - USER_NOT_FOUND

NOTE: In addition common data structures as listed in table 6.2.7-1 are supported.

6.2.3.3 Resource: AmfNon3GppAccessRegistration

6.2.3.3.1 Description

This resource represents the registered AMF for non 3GPP access.

6.2.3.3.2 Resource Definition

Resource URI: {apiRoot}/nudm-uecm/v1/{ueId}/registrations/amf-non-3gpp-access/

This resource shall support the resource URI variables defined in table 6.2.3.3.2-1.

Table 6.2.3.3.2-1: Resource URI variables for this resource

Name	Definition
apiRoot	See subclause 6.2.1
ueId	Represents the Subscription Identifier SUPI or GPSI (see 3GPP TS 23.501 [2] clause 5.9.2) SUPI (i.e. imsi or nai) is used with the PUT and PATCH methods; GPSI (i.e. msisdn or extid) is used with the GET method. pattern: "(imsi-[0-9]{5,15})nai-.+ msisdn-[0-9]{5,15} extid-[^@]+@[^@]+.+"

6.2.3.3.3 Resource Standard Methods

6.2.3.3.3.1 PUT

This method shall support the URI query parameters specified in table 6.2.3.3.3.1-1.

Table 6.2.3.3.3.1-1: URI query parameters supported by the PUT method on this resource

Name	Data type	P	Cardinality	Description
n/a				

This method shall support the request data structures specified in table 6.2.3.3.3.1-2 and the response data structures and response codes specified in table 6.2.3.3.3.1-3.

Table 6.2.3.3.3.1-2: Data structures supported by the PUT Request Body on this resource

Data type	P	Cardinality	Description
AmfNon3GppAccessRegistration	M	1	The AMF registration for non 3GPP access is replaced with the received information.

Table 6.2.3.3.3.1-3: Data structures supported by the PUT Response Body on this resource

Data type	P	Cardinality	Response codes	Description
AmfNon3GppAccessRegistration	M	1	201 Created	Upon success, a response body containing a representation of the created Individual AmfNon3GppAccessRegistration resource shall be returned.
AmfNon3GppAccessRegistration	M	1	200 OK	Upon success, a response body containing a representation of the updated Individual AmfNon3GppAccessRegistration resource shall be returned.
n/a			204 No Content	Upon success, an empty response body shall be returned
ProblemDetails	M	1	404 Not Found	The "cause" attribute shall be set to the following application error: - USER_NOT_FOUND
ProblemDetails	M	1	403 Forbidden	The "cause" attribute shall be set to one of the following application errors: - UNKNOWN_5GS_SUBSCRIPTION - NO_PS_SUBSCRIPTION - ROAMING_NOT_ALLOWED - ACCESS_NOT_ALLOWED - RAT_NOT_ALLOWED - REAUTHENTICATION_REQUIRED
NOTE: In addition common data structures as listed in table 6.2.7-1 are supported.				

6.2.3.3.3.2 PATCH

This method shall support the URI query parameters specified in table 6.2.3.3.3.2-1.

Table 6.2.3.3.3.2-1: URI query parameters supported by the PATCH method on this resource

Name	Data type	P	Cardinality	Description
n/a				

This method shall support the request data structures specified in table 6.2.3.3.3.2-2 and the response data structures and response codes specified in table 6.2.3.3.3.2-3.

Table 6.2.3.3.3.2-2: Data structures supported by the PATCH Request Body on this resource

Data type	P	Cardinality	Description
AmfNon3GppAccessRegistrationModification	M	1	The AMF registration for non 3GPP access is modified with the received information.

Table 6.2.3.3.3.2-3: Data structures supported by the PATCH Response Body on this resource

Data type	P	Cardinality	Response codes	Description
n/a			204 No Content	Upon success, an empty response body shall be returned
ProblemDetails	M	1	404 Not Found	The "cause" attribute shall be set to one of the following application errors: - CONTEXT_NOT_FOUND - USER_NOT_FOUND
ProblemDetails	M	1	422 Unprocessable Entity	The "cause" attribute shall be set to the following application error: - UNPROCESSABLE_REQUEST
NOTE: In addition common data structures as listed in table 6.2.7-1 are supported.				

6.2.3.3.3.3 GET

This method shall support the URI query parameters specified in table 6.2.3.3.3.3-1.

Table 6.2.3.3.3.3-1: URI query parameters supported by the GET method on this resource

Name	Data type	P	Cardinality	Description
n/a				

This method shall support the request data structures specified in table 6.2.3.3.3.3-2 and the response data structures and response codes specified in table 6.2.3.3.3.3-3.

Table 6.2.3.3.3.3-2: Data structures supported by the GET Request Body on this resource

Data type	P	Cardinality	Description
n/a			

Table 6.2.3.3.3.3-3: Data structures supported by the GET Response Body on this resource

Data type	P	Cardinality	Response codes	Description
AmfNon3GppAccessRegistration	M	1	200 OK	Upon success, a response body containing the AmfNon3GppAccessRegistration shall be returned.
ProblemDetails	M	1	404 Not Found	The "cause" attribute shall be set to one of the following application errors: - CONTEXT_NOT_FOUND - USER_NOT_FOUND
NOTE: In addition common data structures as listed in table 6.2.7-1 are supported.				

6.2.3.4 Resource: SmfRegistrations

6.2.3.4.1 Description

This resource is used to represent SMF registrations.

6.2.3.4.2 Resource Definition

Resource URI: {apiRoot}/nudm-uecm/v1/{ueId}/registrations/smf-registrations

This resource shall support the resource URI variables defined in table 6.2.3.4.2-1.

Table 6.2.3.4.2-1: Resource URI variables for this resource

Name	Definition
apiRoot	See subclause 6.4.1
ueId	Represents the Subscription Identifier SUPI or GPSI (see 3GPP TS 23.501 [2] clause 5.9.2) pattern: "(imsi-[0-9]{5,15} nai-.+ msisdn-[0-9]{5,15} extid-[^\@]+@[^\@]+.+)"

6.2.3.4.3 Resource Standard Methods

none

6.2.3.5 Resource: IndividualSmfRegistration

6.2.3.5.1 Resource Definition

Resource URI: {apiRoot}/nudm-uecm/v1/{ueId}/registrations/smf-registrations/{pduSessionId}

This resource shall support the resource URI variables defined in table 6.2.3.5.1-1.

Table 6.2.3.5.1-1: Resource URI variables for this resource

Name	Definition
apiRoot	See subclause 6.1.1
ueId	Represents the Subscription Identifier (see 3GPP TS 23.501 [2] clause 5.9.2) SUPI (i.e. imsi or nai) is used with the PUT, DELETE and PATCH methods; pattern: "(imsi-[0-9]{5,15} nai-.+ msisdn-[0-9]{5,15} extid-[^\@]+@[^\@]+.+)"
pduSessionId	The pduSessionId identifies an individual SMF registration.

6.2.3.5.2 Resource Standard Methods

6.2.3.5.2.1 PUT

This method shall support the URI query parameters specified in table 6.2.3.5.2.1-1.

Table 6.2.3.5.2.1-1: URI query parameters supported by the PUT method on this resource

Name	Data type	P	Cardinality	Description
n/a				

This method shall support the request data structures specified in table 6.2.3.5.2.1-2 and the response data structures and response codes specified in table 6.2.3.5.2.1-3.

Table 6.2.3.5.2.1-2: Data structures supported by the PUT Request Body on this resource

Data type	P	Cardinality	Description
SmfRegistration	M	1	The registration that is to be created

Table 6.2.3.5.2.1-3: Data structures supported by the PUT Response Body on this resource

Data type	P	Cardinality	Response codes	Description
SmfRegistration	M	1	201 Created	Upon success, a response body containing a representation of the created Individual SmfRegistration resource shall be returned.
SmfRegistration	M	1	200 OK	Upon success, a response body containing a representation of the updated Individual SmfRegistration resource shall be returned.
n/a			204 No Content	Upon success, an empty response body shall be returned
ProblemDetails	M	1	404 Not Found	The "cause" attribute shall be set to the following application error: - USER_NOT_FOUND
ProblemDetails	M	1	403 Forbidden	The "cause" attribute shall be set to one of the following application errors: - ROAMING_NOT_ALLOWED - DNN_NOT_ALLOWED
NOTE: In addition common data structures as listed in table 6.4.7-1 are supported.				

6.2.3.5.2.2 DELETE

This method shall support the URI query parameters specified in table 6.2.3.5.2.2-1.

Table 6.2.3.5.2.2-1: URI query parameters supported by the DELETE method on this resource

Name	Data type	P	Cardinality	Description
n/a				

This method shall support the request data structures specified in table 6.2.3.5.2.2-2 and the response data structures and response codes specified in table 6.2.3.5.2.2-3.

Table 6.2.3.5.2.2-2: Data structures supported by the DELETE Request Body on this resource

Data type	P	Cardinality	Description
n/a			The request body shall be empty.

Table 6.2.3.5.2.2-3: Data structures supported by the DELETE Response Body on this resource

Data type	P	Cardinality	Response codes	Description
n/a			204 No Content	Upon success, an empty response body shall be returned.
NOTE: In addition common data structures as listed in table 6.4.7-1 are supported.				

6.2.3.6 Resource: Smsf3GppAccessRegistration

6.2.3.6.1 Description

This resource represents the registered SMSF for 3GPP access.

6.2.3.6.2 Resource Definition

Resource URI: {apiRoot}/nudm-uecm/v1/{ueId}/registrations/smsf-3gpp-access

This resource shall support the resource URI variables defined in table 6.2.3.6.2-1.

Table 6.2.3.6.2-1: Resource URI variables for this resource

Name	Definition
apiRoot	See subclause 6.2.1
ueld	Represents the Subscription Identifier SUPI or GPSI (see 3GPP TS 23.501 [2] clause 5.9.2) SUPI (i.e. imsi or nai) is used with the PUT, DELETE and PATCH methods; GPSI (i.e. msisdn or extid) is used with the GET method. pattern: "(imsi-[0-9]{5,15} nai-.+ msisdn-[0-9]{5,15} extid-[^@]+@[^@]+.+)"

6.2.3.6.3 Resource Standard Methods

6.2.3.6.3.1 PUT

This method shall support the URI query parameters specified in table 6.2.3.6.3.1-1.

Table 6.2.3.6.3.1-1: URI query parameters supported by the PUT method on this resource

Name	Data type	P	Cardinality	Description
n/a				

This method shall support the request data structures specified in table 6.2.3.6.3.1-2 and the response data structures and response codes specified in table 6.2.3.6.3.1-3.

Table 6.2.3.6.3.1-2: Data structures supported by the PUT Request Body on this resource

Data type	P	Cardinality	Description
SmsfRegistration	M	1	The SMSF registration for 3GPP access is created or updated with the received information.

Table 6.2.3.6.3.1-3: Data structures supported by the PUT Response Body on this resource

Data type	P	Cardinality	Response codes	Description
SmsfRegistration	M	1	201 Created	Upon success, a response body containing a representation of the created Individual SmsfRegistration resource shall be returned.
SmsfRegistration	M	1	200 OK	Upon success, a response body containing a representation of the updated Individual SmsfRegistration resource shall be returned.
n/a			204 No Content	Upon success, an empty response body shall be returned
ProblemDetails	M	1	404 Not Found	The "cause" attribute shall be set to the following application error: - USER_NOT_FOUND
ProblemDetails	M	1	403 Forbidden	The "cause" attribute shall be set to one of the following application errors: - UNKNOWN_5GS_SUBSCRIPTION - ACCESS_NOT_ALLOWED - ROAMING_NOT_ALLOWED
NOTE: In addition common data structures as listed in table 6.2.7-1 are supported.				

6.2.3.6.3.2 DELETE

This method shall support the URI query parameters specified in table 6.2.3.6.3.2-1.

Table 6.2.3.6.3.2-1: URI query parameters supported by the DELETE method on this resource

Name	Data type	P	Cardinality	Description
n/a				

This method shall support the request data structures specified in table 6.2.3.6.3.2-2 and the response data structures and response codes specified in table 6.2.3.6.3.2-3.

Table 6.2.3.6.3.2-2: Data structures supported by the DELETE Request Body on this resource

Data type	P	Cardinality	Description
n/a			The request body shall be empty.

Table 6.2.3.6.3.2-3: Data structures supported by the DELETE Response Body on this resource

Data type	P	Cardinality	Response codes	Description
n/a			204 No Content	Upon success, an empty response body shall be returned.
NOTE: In addition common data structures as listed in table 6.4.7-1 are supported.				

6.2.3.6.3.3 GET

This method shall support the URI query parameters specified in table 6.2.3.6.3.3-1.

Table 6.2.3.6.3.3-1: URI query parameters supported by the GET method on this resource

Name	Data type	P	Cardinality	Description
supported-features	SupportedFeatures	O	0..1	see 3GPP TS 29.500 [4] subclause 6.6

This method shall support the request data structures specified in table 6.2.3.6.3.3-2 and the response data structures and response codes specified in table 6.2.3.6.3.3-3.

Table 6.2.3.6.3.3-2: Data structures supported by the GET Request Body on this resource

Data type	P	Cardinality	Description
n/a			

Table 6.2.3.6.3.3-3: Data structures supported by the GET Response Body on this resource

Data type	P	Cardinality	Response codes	Description
SmsfRegistration	M	1	200 OK	Upon success, a response body containing the SmsfRegistration shall be returned.
ProblemDetails	M	1	404 Not Found	The "cause" attribute shall be set to one of the following application errors: - CONTEXT_NOT_FOUND - USER_NOT_FOUND
NOTE: In addition common data structures as listed in table 6.2.7-1 are supported.				

6.2.3.7 Resource: SmsfNon3GppAccessRegistration

6.2.3.7.1 Description

This resource represents the registered SMSF for non 3GPP access.

6.2.3.7.2 Resource Definition

Resource URI: {apiRoot}/nudm-uecm/v1/{ueId}/registrations/smsf-non-3gpp-access

This resource shall support the resource URI variables defined in table 6.2.3.7.2-1.

Table 6.2.3.7.2-1: Resource URI variables for this resource

Name	Definition
apiRoot	See subclause 6.2.1
ueld	Represents the Subscription Identifier SUPI or GPSI (see 3GPP TS 23.501 [2] clause 5.9.2) SUPI (i.e. imsi or nai) is used with the PUT, DELETE and PATCH methods; GPSI (i.e. msisdn or extid) is used with the GET method. pattern: "(imsi-[0-9]{5,15} nai-.+ msisdn-[0-9]{5,15} extid-[^\@]+\@[^\@]+\.)"

6.2.3.7.3 Resource Standard Methods

6.2.3.7.3.1 PUT

This method shall support the URI query parameters specified in table 6.2.3.7.3.1-1.

Table 6.2.3.7.3.1-1: URI query parameters supported by the PUT method on this resource

Name	Data type	P	Cardinality	Description
n/a				

This method shall support the request data structures specified in table 6.2.3.7.3.1-2 and the response data structures and response codes specified in table 6.2.3.7.3.1-3.

Table 6.2.3.7.3.1-2: Data structures supported by the PUT Request Body on this resource

Data type	P	Cardinality	Description
SmsfRegistration	M	1	The SMSF registration for non 3GPP access is created or updated with the received information.

Table 6.2.3.7.3.1-3: Data structures supported by the PUT Response Body on this resource

Data type	P	Cardinality	Response codes	Description
SmsfRegistration	M	1	201 Created	Upon success, a response body containing a representation of the created Individual SmsfRegistration for non 3GPP access resource shall be returned.
SmsfRegistration	M	1	200 OK	Upon success, a response body containing a representation of the updated Individual SmsfRegistration for non 3GPP access resource shall be returned.
n/a			204 No Content	Upon success, an empty response body shall be returned
ProblemDetails	M	1	404 Not Found	The "cause" attribute shall be set to the following application error: - USER_NOT_FOUND
ProblemDetails	M	1	403 Forbidden	The "cause" attribute shall be set to one of the following application errors: - UNKNOWN_5GS_SUBSCRIPTION - ACCESS_NOT_ALLOWED - ROAMING_NOT_ALLOWED
NOTE: In addition common data structures as listed in table 6.2.7-1 are supported.				

6.2.3.7.3.2 DELETE

This method shall support the URI query parameters specified in table 6.2.3.7.2.2-1.

Table 6.2.3.7.2.2-1: URI query parameters supported by the DELETE method on this resource

Name	Data type	P	Cardinality	Description
n/a				

This method shall support the request data structures specified in table 6.2.3.7.2.2-2 and the response data structures and response codes specified in table 6.2.3.5.2.2-3.

Table 6.2.3.7.2.2-2: Data structures supported by the DELETE Request Body on this resource

Data type	P	Cardinality	Description
n/a			The request body shall be empty.

Table 6.2.3.7.2.2-3: Data structures supported by the DELETE Response Body on this resource

Data type	P	Cardinality	Response codes	Description
n/a			204 No Content	Upon success, an empty response body shall be returned.
NOTE: In addition common data structures as listed in table 6.4.7-1 are supported.				

6.2.3.7.3.3 GET

This method shall support the URI query parameters specified in table 6.2.3.7.3.3-1.

Table 6.2.3.7.3.3-1: URI query parameters supported by the GET method on this resource

Name	Data type	P	Cardinality	Description
supported-features	SupportedFeatures	O	0..1	see 3GPP TS 29.500 [4] subclause 6.6

This method shall support the request data structures specified in table 6.2.3.7.3.3-2 and the response data structures and response codes specified in table 6.2.3.7.3.3-3.

Table 6.2.3.7.3.3-2: Data structures supported by the GET Request Body on this resource

Data type	P	Cardinality	Description
n/a			

Table 6.2.3.7.3.3-3: Data structures supported by the GET Response Body on this resource

Data type	P	Cardinality	Response codes	Description
SmsfRegistration	M	1	200 OK	Upon success, a response body containing the SmsfRegistration shall be returned.
ProblemDetails	M	1	404 Not Found	The "cause" attribute shall be set to one of the following application errors: - CONTEXT_NOT_FOUND - USER_NOT_FOUND
NOTE: In addition common data structures as listed in table 6.2.7-1 are supported.				

6.2.4 Custom Operations without associated resources

In this release of this specification, no custom operations without associated resources are defined for the Nudm_UEContextManagement Service.

6.2.5 Notifications

6.2.5.1 General

This subclause will specify the use of notifications and corresponding protocol details if required for the specific service. When notifications are supported by the API, it will include a reference to the general description of notifications support over the 5G SBIs specified in TS 29.500 / TS 29.501.

6.2.5.2 Deregistration Notification

The POST method shall be used for Deregistration Notifications and the URI shall be as provided during the registration procedure.

Resource URI: {callbackReference}

Support of URI query parameters is specified in table 6.2.5.2-1.

Table 6.2.5.2-1: URI query parameters supported by the POST method

Name	Data type	P	Cardinality	Description
n/a				

Support of request data structures is specified in table 6.2.5.2-2 and of response data structures and response codes is specified in table 6.2.5.2-3.

Table 6.2.5.2-2: Data structures supported by the POST Request Body

Data type	P	Cardinality	Description
DeregistrationData	M	1	Includes Deregistration Reason

Table 6.2.5.2-3: Data structures supported by the POST Response Body

Data type	P	Cardinality	Response codes	Description
n/a			204 No Content	Upon success, an empty response body shall be returned.
ProblemDetails	M	1	404 Not Found	The "cause" attribute shall be set to the following application error: - CONTEXT_NOT_FOUND
NOTE: In addition common data structures as listed in table 6.1.7-1 are supported.				

6.2.5.3 P-CSCF Restoration Notification

The POST method shall be used for P-CSCF Restoration Notifications and the URI shall be as provided during the registration procedure.

Resource URI: {callbackReference}

Support of URI query parameters is specified in table 6.2.5.3-1.

Table 6.2.5.3-1: URI query parameters supported by the POST method

Name	Data type	P	Cardinality	Description
n/a				

Support of request data structures is specified in table 6.2.5.3-2 and of response data structures and response codes is specified in table 6.2.5.3-3.

Table 6.2.5.3-2: Data structures supported by the POST Request Body

Data type	P	Cardinality	Description
PcscfRestorationNotification	M	1	contains the SUPI

Table 6.2.5.3-3: Data structures supported by the POST Response Body

Data type	P	Cardinality	Response codes	Description
n/a			204 No Content	Upon success, an empty response body shall be returned.
ProblemDetails	M	1	404 Not Found	The "cause" attribute shall be set to the following application error: - CONTEXT_NOT_FOUND
NOTE: In addition common data structures as listed in table 6.1.7-1 are supported.				

6.2.6 Data Model

6.2.6.1 General

This subclause specifies the application data model supported by the API.

Table 6.2.6.1-1 specifies the structured data types defined for the Nudm_UECM service API. For simple data types defined for the Nudm_UECM service API see table 6.2.6.3.2-1.

Table 6.2.6.1-1: Nudm_UECM specific Data Types

Data type	Section defined	Description
Amf3GppAccessRegistration	6.2.6.2.2	The complete set of information relevant to the AMF where the UE has registered via 3GPP access.
PurgeFlag	6.2.6.3.2	This flag indicates whether or not the NF has deregistered.
AmfNon3GppAccessRegistration	6.2.6.2.3	The complete set of information relevant to the AMF where the UE has registered via non 3GPP access.
DeregistrationData	6.2.6.2.5	Data sent with the Deregistration Notification
SmfRegistration	6.2.6.2.4	The complete set of information relevant to an SMF serving the UE
SmsfRegistration	6.2.6.2.6	The complete set of information relevant to the SMSF serving the UE.
Amf3GppAccessRegistrationModification	6.2.6.2.7	Contains attributes of Amf3GppAccessRegistration that can be modified using PATCH
AmfNon3GppAccessRegistrationModification	6.2.6.2.8	Contains attributes of AmfNon3GppAccessRegistration that can be modified using PATCH
PcscfRestorationNotification	6.2.6.2.9	Information sent to the AMF or SMF when P-CSCF restoration is triggered.
DualRegistrationFlag	6.2.6.3.2	Dual Registration Flag

Table 6.2.6.1-2 specifies data types re-used by the Nudm_uecm service API from other specifications, including a reference to their respective specifications and when needed, a short description of their use within the Nudm_uecm service API.

Table 6.2.6.1-2: Nudm_UECM re-used Data Types

Data type	Reference	Comments
Dnn	3GPP TS 29.571 [7]	Data Network Name
NfnInstancelId	3GPP TS 29.571 [7]	Network Function Instance Identifier
PduSessionId	3GPP TS 29.571 [7]	PDU Session ID
Pei	3GPP TS 29.571 [7]	Permanent Equipment Identifier
ProblemDetails	3GPP TS 29.571 [7]	Common data type used in response bodies
Uri	3GPP TS 29.571 [7]	Uniform Resource Identifier
SupportedFeatures	3GPP TS 29.571 [7]	see 3GPP TS 29.500 [4] subclause 6.6
Supi	3GPP TS 29.571 [7]	see 3GPP TS 23.501 [2] subclause 5.9.2
Guami	3GPP TS 29.571 [7]	Globally Unique AMF Identifier
PlmnId	3GPP TS 29.571 [7]	PLMN Identity
DiameterIdentity	3GPP TS 29.571 [7]	
AccessType	3GPP TS 29.571 [7]	Access Type
BackupAmfInfo	3GPP TS 29.571 [7]	Backup AMFs
ServiceName	3GPP TS 29.510 [19]	

6.2.6.2 Structured data types

6.2.6.2.1 Introduction

This subclause defines the structures to be used in resource representations.

6.2.6.2.2 Type: Amf3GppAccessRegistration

Table 6.2.6.2.2-1: Definition of type Amf3GppAccessRegistration

Attribute name	Data type	P	Cardinality	Description
amfInstanceid	NfInstanceid	M	1	The identity the AMF uses to register in the NRF.
deregCallbackUri	Uri	M	1	A URI provided by the AMF to receive (implicitly subscribed) notifications on deregistration. The deregistration callback URI shall have unique information within AMF set to identify the UE to be deregistered.
guami	Guami	M	1	This IE shall contain the serving AMF's GUAMI.
ratType	RatType	M	1	This IE shall indicate the current RAT type of the UE.
supportedFeatures	SupportedFeatures	O	0..1	See subclause 6.2.8
purgeFlag	PurgeFlag	O	0..1	This flag indicates whether or not the AMF has deregistered. It shall not be included in the Registration service operation.
pei	Pei	O	0..1	Permanent Equipment Identifier.
imsVoPs	ImsVoPs	O	0..1	Indicates per UE if "IMS Voice over PS Sessions" is homogeneously supported in all TAs in the serving AMF, or homogeneously not supported, or if support is non-homogeneous/unknown. Absence of this attribute shall be interpreted as "non homogenous or unknown" support.
amfServiceNameDereg	ServiceName	O	0..1	When present, this IE shall contain the name of the AMF service to which the Deregistration Notification is to be sent (see subclause 6.5.2.2 of 3GPP TS 29.500 [4]).
pcscfRestorationCallbackUri	Uri	O	0..1	A URI provided by the AMF to receive (implicitly subscribed) notifications on the need for P-CSCF Restoration.
amfServiceNamePcscfRest	ServiceName	O	0..1	When present, this IE shall contain the name of the AMF service to which P-CSCF Restoration Notifications are to be sent (see subclause 6.5.2.2 of 3GPP TS 29.500 [4]). This IE may be included if pcscfRestorationCallbackUri is present.
initialRegistrationInd	boolean	C	0..1	This IE shall be included by the AMF and set to true if the UE performs an Initial Registration. If the UE does not perform initial registration it shall be absent or set to false.
backupAmfInfo	array(BackupAmfInfo)	C	1..N	This IE shall be included if the NF service consumer is an AMF and the AMF supports the AMF management without UDSF for the first interaction with UDM. The UDM uses this attribute to do an NRF query in order to invoke later services in a backup AMF, e.g. Namf_EventExposure.
drFlag	DualRegistrationFlag	O	0..1	Dual Registration flag. When present and true, this flag indicates that the UDM+HSS is requested not to send S6a-CLR to the registered MME (if any). Otherwise, the registered MME (if any) shall be cancelled.

6.2.6.2.3 Type: AmfNon3GppAccessRegistration

Table 6.2.6.2.3-1: Definition of type AmfNon3GppAccessRegistration

Attribute name	Data type	P	Cardinality	Description
amfInstancelid	NfInstancelid	M	1	The identity the AMF uses to register in the NRF.
deregCallbackUri	Uri	M	1	A URI provided by the AMF to receive (implicitly subscribed) notifications on deregistration. The deregistration callback URI shall have unique information within AMF set to identify the UE to be deregistered.
guami	Guami	M	1	This IE shall contain the serving AMF's GUAMI.
ratType	RatType	M	1	This IE shall indicate the current RAT type of the UE.
supportedFeatures	SupportedFeatures	O	0..1	See subclause 6.2.8
purgeFlag	PurgeFlag	O	0..1	This flag indicates whether or not the AMF has deregistered. It shall not be included in the Registration service operation.
pei	Pei	O	0..1	Permanent Equipment Identifier
imsVoPs	ImsVoPs	M	1	Indicates per UE if "IMS Voice over PS Sessions" is supported, or not supported. The value NON_HOMOGENEOUS_OR_UNKNOWN is not applicable.
amfServiceNameDereg	ServiceName	O	0..1	When present, this IE shall contain the name of the AMF service to which the Deregistration Notification is to be sent (see subclause 6.5.2.2 of 3GPP TS 29.500 [4]).
pcscfRestorationCallbackUri	Uri	O	0..1	A URI provided by the AMF to receive (implicitly subscribed) notifications on the need for P-CSCF Restoration.
amfServiceNamePcscfRest	ServiceName	O	0..1	When present, this IE shall contain the name of the AMF service to which P-CSCF Restoration Notifications are to be sent (see subclause 6.5.2.2 of 3GPP TS 29.500 [4]). This IE may be included if pcscfRestorationCallbackUri is present.
backupAmfInfo	array(BackupAmfInfo)	C	1..N	This IE shall be included if the NF service consumer is an AMF and the AMF supports the AMF management without UDSF for the first interaction with UDM. The UDM uses this attribute to do an NRF query in order to invoke later services in a backup AMF, e.g. Namf_EventExposure.

6.2.6.2.4 Type: SmfRegistration

Table 6.2.6.2.4-1: Definition of type SmfRegistration

Attribute name	Data type	P	Cardinality	Description
smfInstanceId	NfInstanceId	M	1	NF Instance Id of the SMF
supportedFeatures	SupportedFeatures	O	0..1	See subclause 6.2.8
pduSessionId	PduSessionId	M	1	PDU Session ID
singleNssai	Snssai	M	1	A single Network Slice Selection Assistance Information
dnn	Dnn	M	1	Data Network Name
pcscfRestorationCallbackUri	Uri	O	0..1	a URI provided by the SMF to receive (implicitly subscribed) notifications on the need for P-CSCF Restoration
plmnId	PlmnId	M	1	Serving node PLMN identity.
pgwFqdn	string	C	0..1	FQDN of the PGW in the "PGW-C+SMF", to be included for interworking with EPS.

6.2.6.2.5 Type: DeregistrationData

Table 6.2.6.2.5-1: Definition of type DeregistrationData

Attribute name	Data type	P	Cardinality	Description
deregReason	DeregistrationReason	M	1	String; see subclause 6.2.6.3.3
accessType	AccessType	M	1	Access type where the UE is deregistered

6.2.6.2.6 Type: SmsfRegistration

Table 6.2.6.2.6-1: Definition of type SmsfRegistration

Attribute name	Data type	P	Cardinality	Description
smsfInstanceId	NfInstanceId	M	1	NF Instance Id of the SMSF
supportedFeatures	SupportedFeatures	O	0..1	See subclause 6.2.8
plmnId	PlmnId	M	1	Serving node PLMN identity
smsfMAPAddress	E164Number	C	0..1	International E.164 number of the SMSF; shall be present if the SMSF supports MAP (see 3GPP TS 29.002 [21])
smsfDiameterAddress	NetworkNodeDiameterAddress	C	0..1	shall be present if the SMSF supports Diameter (see 3GPP TS 29.338 [22])

6.2.6.2.7 Type: Amf3GppAccessRegistrationModification

This type is derived from the type Amf3GppAccessRestriction by deleting all attributes that are not subject to modification by means of the HTTP PATCH method.

Table 6.2.6.2.7-1: Definition of type Amf3GppAccessRegistrationModification

Attribute name	Data type	P	Cardinality	Description
guami	Guami	M	1	Guami of the AMF requesting the modification. If the MCC, MNC, AMF Region ID and AMF Set ID within the guami do not match the stored value, the modification request shall be rejected.
purgeFlag	PurgeFlag	O	0..1	This flag indicates whether or not the AMF has deregistered. It shall be included in the Deregistration service operation with a value of "TRUE".
pei	Pei	O	0..1	Permanent Equipment Identifier.
imsVoPs	ImsVoPs	O	0..1	Indicates per UE if "IMS Voice over PS Sessions" is homogeneously supported in all TAs in the serving AMF, or homogeneously not supported, or if support is non-homogeneous/unknown
backupAmfInfo	array(BackupAmfInfo)	C	0..N	This IE shall be included if the NF service consumer is an AMF and the AMF supports the AMF management without UDSF for the Modification of the BackupAmfInfo. The UDM uses this attribute to do an NRF query in order to invoke later services in a backup AMF, e.g. Namf_EventExposure
Note:	Absence of optional attributes indicates: no modification. Attributes of this type are not marked "nullable: true" in the OpenAPI file as deletion of these attributes is not applicable.			

6.2.6.2.8 Type: AmfNon3GppAccessRegistrationModification

This type is derived from the type Amf3NonGppAccessRestriction by deleting all attributes that are not subject to modification by means of the HTTP PATCH method.

Table 6.2.6.2.8-1: Definition of type AmfNon3GppAccessRegistrationModification

Attribute name	Data type	P	Cardinality	Description
guami	Guami	M	1	Guami of the AMF requesting the modification. If the MCC, MNC, AMF Region ID and AMF Set ID within the guami do not match the stored value, the modification request shall be rejected.
purgeFlag	PurgeFlag	O	0..1	This flag indicates whether or not the AMF has deregistered. It shall be included in the Deregistration service operation with a value of "TRUE".
pei	Pei	O	0..1	Permanent Equipment Identifier
imsVoPs	ImsVoPs	O	0..1	If present indicates per UE that support of "IMS Voice over PS Sessions" has been modified to supported or not supported". The value NON_HOMOGENEOUS_OR_UNKNOWN is not applicable.
backupAmfInfo	array(BackupAmfInfo)	C	0..N	This IE shall be included if the NF service consumer is an AMF and the AMF supports the AMF management without UDSF for the Modification of the BackupAmfInfo. The UDM uses this attribute to do an NRF query in order to invoke later services in a backup AMF, e.g. Namf_EventExposure
Note:	Absence of optional attributes indicates: no modification. Attributes of this type are not marked "nullable: true" in the OpenAPI file as deletion of these attributes is not applicable.			

6.2.6.2.9 Type: PcsfcRestorationNotification

Table 6.2.6.2.9-1: Definition of type PcsfcRestorationNotification

Attribute name	Data type	P	Cardinality	Description
supi	Supi	M	1	A SUPI that is served by the failed P-CSCF

6.2.6.2.10 Type: NetworkNodeDiameterAddress

Table 6.2.6.2.10-1: Definition of type NetworkNodeDiameterAddress

Attribute name	Data type	P	Cardinality	Description
name	DiameterIdentity	M	1	
realm	DiameterIdentity	M	1	

6.2.6.3 Simple data types and enumerations

6.2.6.3.1 Introduction

This subclause defines simple data types and enumerations that can be referenced from data structures defined in the previous subclauses.

6.2.6.3.2 Simple data types

The simple data types defined in table 6.2.6.3.2-1 shall be supported.

Table 6.2.6.3.2-1: Simple data types

Type Name	Type Definition	Description
PurgeFlag	boolean	This flag indicates whether or not the NF has deregistered.
E164Number	string	see ITU-T Recommendation E.164 [23] pattern: [0-9]{1,15}
DualRegistrationFlag	boolean	Dual Registration Flag

6.2.6.3.3 Enumeration: DeregistrationReason

The enumeration DeregistrationReason represents the reason for the Deregistration Notification. It shall comply with the provisions defined in table 6.2.6.3.3-1.

Table 6.2.6.3.3-1: Enumeration DeregistrationReason

Enumeration value	Description
"UE_INITIAL_REGISTRATION"	see 3GPP TS 23.502 [3]
"UE_REGISTRATION_AREA_CHANGE"	see 3GPP TS 23.502 [3]
"SUBSCRIPTION_WITHDRAWN"	see 3GPP TS 23.502 [3]
"5GS_TO_EPS_MOBILITY"	see 3GPP TS 23.502 [3]
"5GS_TO_EPS_MOBILITY_UE_INITIAL_REGISTRATION"	see 3GPP TS 23.502 [3]
"REREGISTRATION_REQUIRED"	see 3GPP TS 23.502 [3]

6.2.6.3.4 Enumeration: ImsVoPs

The enumeration ImsVoPs represents information indicating homogeneity of IMS Voice over PS Sessions support for the UE. It shall comply with the provisions defined in table 6.2.6.3.4-1.

Table 6.2.6.3.4-1: Enumeration ImsVoPs

Enumeration value	Description
"HOMOGENEOUS_SUPPORT"	"IMS Voice over PS Sessions" is homogeneously supported in all TAs in the serving AMF.
"HOMOGENEOUS_NON_SUPPORT"	"IMS Voice over PS Sessions" is homogeneously not supported in all TAs in the serving AMF.
"NON_HOMOGENEOUS_OR_UNKNOWN"	"IMS Voice over PS Sessions" is not homogeneously supported in all TAs in the serving AMF, or its support is unknown.

6.2.7 Error Handling

6.2.7.1 General

HTTP error handling shall be supported as specified in subclause 5.2.4 of 3GPP TS 29.500 [4].

6.2.7.2 Protocol Errors

Protocol errors handling shall be supported as specified in subclause 5.2.7 of 3GPP TS 29.500 [4].

6.2.7.3 Application Errors

The common application errors defined in the Table 5.2.7.2-1 in 3GPP TS 29.500 [4] may also be used for the Nudm_UEContextManagement service. The following application errors listed in Table 6.2.7.3-1 are specific for the Nudm_UEContextManagement service.

Table 6.2.7.3-1: Application errors

Application Error	HTTP status code	Description
UNKNOWN_5GS_SUBSCRIPTION	403 Forbidden	No 5GS subscription is associated with the user.
NO_PS_SUBSCRIPTION	403 Forbidden	No PS (5GS, EPS, GPRS) subscription is associated with the user.
ROAMING_NOT_ALLOWED	403 Forbidden	The subscriber is not allowed to roam within that PLMN
USER NOT FOUND	404 Not Found	The user does not exist in the HPLMN
CONTEXT_NOT_FOUND	404 Not Found	It is used during the modification of an existing subscription when no corresponding context exists.
ACCESS_NOT_ALLOWED	403 Forbidden	Access type not allowed for the user.
RAT_NOT_ALLOWED	403 Forbidden	RAT is not allowed for the user
DNN_NOT_ALLOWED	403 Forbidden	DNN not authorized for the user
REAUTHENTICATION_REQUIRED	403 Forbidden	Due to operator policies the user needs to be re-authenticated, e.g. last valid authentication is considered obsolete
INVALID_GUAMI	403 Forbidden	The AMF is not allowed to modify the registration information stored in the UDM, as it is not the registered AMF.
UNPROCESSABLE_REQUEST	422 Unprocessable Entity	The request cannot be processed due to semantic errors when trying to process a patch method

6.2.8 Feature Negotiation

The optional features in table 6.2.8-1 are defined for the Nudm_UECM API. They shall be negotiated using the extensibility mechanism defined in subclause 6.6 of 3GPP TS 29.500 [4].

Table 6.2.8-1: Supported Features

Feature number	Feature Name	Description
1	SharedData	When receiving a Nudm_UECM_Registration service operation request for a UE that shares subscription data with other UEs, and the request does not indicate support of this feature by the service consumer, the UDM may – based on operator policy – decide to reject the registration.

6.2.9 Security

As indicated in 3GPP TS 33.501 [6] and 3GPP TS 29.500 [4], the access to the Nudm_UECM API may be authorized by means of the OAuth2 protocol (see IETF RFC 6749 [18]), based on local configuration, using the "Client Credentials" authorization grant, where the NRF (see 3GPP TS 29.510 [19]) plays the role of the authorization server.

If OAuth2 is used, an NF Service Consumer, prior to consuming services offered by the Nudm_UECM API, shall obtain a "token" from the authorization server, by invoking the Access Token Request service, as described in 3GPP TS 29.510 [19], subclause 5.4.2.2.

NOTE: When multiple NRFs are deployed in a network, the NRF used as authorization server is the same NRF that the NF Service Consumer used for discovering the Nudm_UECM service.

The Nudm_UECM API defines a single scope "nudm-uecm" for OAuth2 authorization (as specified in 3GPP TS 33.501 [6]) for the entire API, and it does not define any additional scopes at resource or operation level.

6.3 Nudm_UEAuthentication Service API

6.3.1 API URI

URIs of this API shall have the following root:

```
{apiRoot}/{apiName}/{apiVersion}/
```

where "apiRoot" is defined in subclause 4.4.1 of 3GPP TS 29.501 [5], the "apiName" shall be set to "nudm-ueau" and the "apiVersion" shall be set to "v1" for the current version of this specification.

6.3.2 Usage of HTTP

6.3.2.1 General

HTTP/2, as defined in IETF RFC 7540 [13], shall be used as specified in clause 5 of 3GPP TS 29.500 [4].

HTTP/2 shall be transported as specified in subclause 5.3 of 3GPP TS 29.500 [4].

HTTP messages and bodies for the Nudm_UEAU service shall comply with the OpenAPI [14] specification contained in Annex A4.

6.3.2.2 HTTP standard headers

6.3.2.2.1 General

The usage of HTTP standard headers shall be supported as specified in subclause 5.2.2 of 3GPP TS 29.500 [4].

6.3.2.2.2 Content type

The following content types shall be supported:

JSON, as defined in IETF RFC 8259 [15], signalled by the content type "application/json".

The Problem Details JSON Object (IETF RFC 7807 [16]) signalled by the content type "application/problem+json"

6.3.2.3 HTTP custom headers

6.3.2.3.1 General

The usage of HTTP custom headers shall be supported as specified in subclause 5.2.3 of 3GPP TS 29.500 [4].

6.3.3 Resources

6.3.3.1 Overview

Figure 6.3.3.1-1 describes the resources supported by the Nudm_UEAU API.

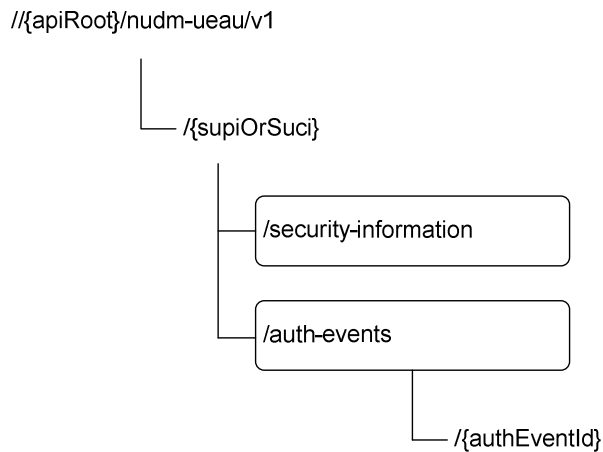

Figure 6.3.3.1-1: Resource URI structure of the nudm_ueau API

Table 6.3.3.1-1 provides an overview of the resources and applicable HTTP methods.

Table 6.3.3.1-1: Resources and methods overview

Resource name (Archetype)	Resource URI	HTTP method or custom operation	Description
SecurityInformation (Custom operation)	/{{supiOrSuci}}/security-information/generate-auth-data	generate-auth-data (POST)	If the variable {supiOrSuci} takes the value of a SUCI, the UDM calculates the corresponding SUPI. The UDM calculates a fresh authentication vector based on the received security information and the stored security information for the SUPI if 5G-AKA or EAP-AKA' is selected. Otherwise, UDM provides corresponding authentication information.
AuthEvents (Collection)	/{{supi}}/auth-events	POST	Create an Authentication Event

6.3.3.2 Resource: SecurityInformation

6.3.3.2.1 Description

This resource represents the information that is needed together with the serving network name and the access type to calculate a fresh authentication vector. See 3GPP TS 33.501 [6].

6.3.3.2.2 Resource Definition

Resource URI: {apiRoot}/nudm-ueau/v1/{supiOrSuci}/security-information

This resource shall support the resource URI variables defined in table 6.3.3.2-1.

Table 6.3.3.2.2-1: Resource URI variables for this resource

Name	Definition
apiRoot	See subclause 6.3.1
supiOrSuci	Represents the Subscription Permanent Identifier (see 3GPP TS 23.501 [2] subclause 5.9.2), or Subscription Concealed Identifier (see 3GPP TS 23.003 [8]). Pattern: "^(\imsi-[0-9]{5,15} nai-.+ suci-(0-[0-9]{3}-[0-9]{2,3}){1-7}-[0-9]{1,4}-(0-0- [a-fA-F1-9]-([1-9])?[1-9][0-9]1[0-9]{2}2[0-4][0-9]25[0-5]-[a-fA-F0-9]+).+)\$" (See NOTE).
NOTE:	The format for SUCI, when the corresponding SUPI is NAI-based, contains a realm that may include a "minus" character ("-"), which is also used as field separator. Given that the NAI and its realm shall conform to IETF RFC 7542 [29], the regular expression defined here allows for non-ambiguous matching of the different fields of the SUCI, even when the realm contains the "minus" character.

6.3.3.2.3 Resource Standard Methods

No Standard Methods are supported for this resource.

6.3.3.2.4 Resource Custom Operations

6.3.3.2.4.1 Overview

Table 6.3.3.2.4.1-1: Custom operations

Custom operation URI	Mapped HTTP method	Description
/generate-auth-data	POST	Select the authentication method and calculate a fresh AV if 5G-AKA or EAP-AKA' is selected or provides corresponding authentication information.

6.3.3.2.4.2 Operation: generate-auth-data

6.3.3.2.4.2.1 Description

This custom operation is used by the NF service consumer (AUSF) to request authentication information data for the SUPI/SUCI from the UDM. If SUCI is provided, the UDM calculates the SUPI from the SUCI (see 3GPP TS 33.501 [6]). The UDM calculates an authentication vector taking into account the information received from the NF service consumer (AUSF) and the current representation of this resource if 5G AKA or EAP-AKA' is selected. For details see 3GPP TS 33.501 [6].

6.3.3.2.4.2.2 Operation Definition

This operation shall support the request data structures specified in table 6.3.3.2.4.2.2-1 and the response data structure and response codes specified in table 6.3.3.2.4.2.2-2.

Table 6.3.3.2.4.2.2-1: Data structures supported by the POST Request Body on this resource

Data type	P	Cardinality	Description
AuthenticationInfo Request	M	1	Contains the serving network name and Resynchronization Information

Table 6.3.3.2.4.2.2-2: Data structures supported by the POST Response Body on this resource

Data type	P	Cardinality	Response codes	Description
AuthenticationInfoResult	M	1	200 OK	Upon success, a response body containing the selected authentication method and an authentication vector if 5G AKA or EAP-AKA' has been selected shall be returned
ProblemDetails	M	1	404 Not Found	The "cause" attribute shall be set to the following application error: - USER_NOT_FOUND
ProblemDetails	M	1	403 Forbidden	The "cause" attribute shall be set to one of the following application errors: - AUTHENTICATION_REJECTED - SERVING_NETWORK_NOT_AUTHORIZED - INVALID_HN_PUBLIC_KEY_IDENTIFIER - INVALID_SCHEME_OUTPUT
ProblemDetails	M	1	501 Not Implemented	The "cause" attribute shall be set to the following application error: - UNSUPPORTED_PROTECTION_SCHEME
NOTE: In addition common data structures as listed in table 6.1.7-1 are supported.				

6.3.3.3 Resource: AuthEvents

6.3.3.3.1 Description

This resource represents the collection of UE authentication events.

6.3.3.3.2 Resource Definition

Resource URI: {apiRoot}/nudm-ueau/v1/{supi}/auth-events

This resource shall support the resource URI variables defined in table 6.3.3.3.2-1.

Table 6.3.3.3.2-1: Resource URI variables for this resource

Name	Definition
apiRoot	See subclause 6.3.1
supi	Represents the Subscription Permanent Identifier (see 3GPP TS 23.501 [2] subclause 5.9.2) pattern: "(imsi-[0-9]{5,15} nai-.+ .+)")

6.3.3.3.3 Resource Standard Methods

6.3.3.3.3.1 POST

This method shall support the URI query parameters specified in table 6.3.3.3.3.1-1.

Table 6.3.3.3.3.1-1: URI query parameters supported by the POST method on this resource

Name	Data type	P	Cardinality	Description
n/a				

This method shall support the request data structures specified in table 6.3.3.3.3.1-2 and the response data structures and response codes specified in table 6.3.3.3.3.1-3.

Table 6.3.3.3.3.1-2: Data structures supported by the POST Request Body on this resource

Data type	P	Cardinality	Description
AuthEvent	M	1	The UE Authentication Event

Table 6.3.3.3.1-3: Data structures supported by the POST Response Body on this resource

Data type	P	Cardinality	Response codes	Description
AuthEvent	O	0..1	201 Created	Upon success, a response body containing a representation of the created Authentication Event may be returned. The HTTP response shall include a "Location" HTTP header that contains the resource URI of the created resource.
ProblemDetails	M	1	404 Not Found	The "cause" attribute shall be set to the following application error: - USER_NOT_FOUND
NOTE: In addition common data structures as listed in table 6.3.7-1 are supported.				

6.3.4 Custom Operations without associated resources

In this release of this specification, no custom operations without associated resources are defined for the Nudm_UEAuthentication Service.

6.3.5 Notifications

In this release of this specification, no notifications are defined for the Nudm_UEAuthentication Service.

6.3.6 Data Model

6.3.6.1 General

This subclause specifies the application data model supported by the API.

Table 6.3.6.1-1 specifies the structured data types defined for the Nudm_UEAU service API. For simple data types defined for the Nudm_UEAU service API see table 6.3.6.3.2-1.

Table 6.3.6.1-1: Nudm_UEAU specific Data Types

Data type	Section defined	Description
AuthenticationInfoRequest	6.3.6.2.2	Contains Serving Network Name and Resynchronization Information
AuthenticationInfoResult	6.3.6.2.3	Contains an Authentication Vector (AV)
AvEapAkaPrime	6.3.6.2.4	Contains RAND, XRES, AUTN, CK', and IK'
Av5GHeAka	6.3.6.2.5	Contains RAND, XRES*, AUTN, KAUSF
AuthEvent	6.3.6.2.7	Authentication Event
ResynchronizationInfo	6.3.6.2.6	Contains RAND and AUTS
AuthenticationVector	6.3.6.2.8	

Table 6.3.6.1-2 specifies data types re-used by the Nudm_UEAU service API from other specifications, including a reference to their respective specifications and when needed, a short description of their use within the Nudm_UEAU service API.

Table 6.3.6.1-2: Nudm_UEAU re-used Data Types

Data type	Reference	Comments
ProblemDetails	3GPP TS 29.571 [7]	Common data type used in response bodies
NfnInstanceId	3GPP TS 29.571 [7]	Network Function Instance Identifier
DateTime	3GPP TS 29.571 [7]	
SupportedFeatures	3GPP TS 29.571 [7]	see 3GPP TS 29.500 [4] subclause 6.6
Supi	3GPP TS 29.571 [7]	

6.3.6.2 Structured data types

6.3.6.2.1 Introduction

This subclause defines the structures to be used in POST request / response bodies.

6.3.6.2.2 Type: AuthenticationInfoRequest

Table 6.3.6.2.2-1: Definition of type AuthenticationInfoRequest

Attribute name	Data type	P	Cardinality	Description
servingNetworkName	ServingNetworkName	M	1	See 3GPP TS 33.501 [6] subclause 6.1.1.3
resynchronizationInfo	ResynchronizationInfo	O	0..1	Contains RAND and AUTS; see 3GPP TS 33.501 [6] subclause 7.5
supportedFeatures	SupportedFeatures	O	0..1	See subclause 6.3.8
ausfInstanceid	NfInstanceid	M	1	NF Instance Id of the AUSF

6.3.6.2.3 Type: AuthenticationInfoResult

Table 6.3.6.2.3-1: Definition of type AuthenticationInfoResult

Attribute name	Data type	P	Cardinality	Description
authType	AuthType	M	1	Indicates the authentication method
authenticationVector	AuthenticationVector	C	0..1	contains an authentication vector if 5G AKA or EAP-AKA's is selected
supi	Supi	C	0..1	SUPI shall be present if the request contained the SUCI within the request URI
supportedFeatures	SupportedFeatures	O	0..1	See subclause 6.3.8

6.3.6.2.4 Type: AvEapAkaPrime

Table 6.3.6.2.4-1: Definition of type AvEapAkaPrime

Attribute name	Data type	P	Cardinality	Description
avType	AvType	M	1	Type of authentication vector
rand	Rand	M	1	
xres	Xres	M	1	
autn	Autn	M	1	
ckPrime	CkPrime	M	1	
ikPrime	IkPrime	M	1	

6.3.6.2.5 Type: Av5GHeAka

Table 6.3.6.2.5-1: Definition of type Av5GAka

Attribute name	Data type	P	Cardinality	Description
avType	AvType	M	1	Type of authentication vector
rand	Rand	M	1	
xresStar	XresStar	M	1	
autn	Autn	M	1	
kauf	Kauf	M	1	

6.3.6.2.6 Type: ResynchronizationInfo

Table 6.3.6.2.6-1: Definition of type ResynchronizationInfo

Attribute name	Data type	P	Cardinality	Description
rand	Rand	M	1	
auts	Auts	M	1	

6.3.6.2.7 Type: AuthEvent

Table 6.3.6.2.7-1: Definition of type AuthEvent

Attribute name	Data type	P	Cardinality	Description
nfnInstanceIcd	NfnInstanceIcd	M	1	Identifier of the NF instance where the authentication occurred
success	Success	M	1	true indicates success; false indicates no success
timeStamp	DateTime	M	1	time stamp of the authentication
authType	AuthType	M	1	string Authentication Type ("EAP_AKA_PRIME" or "5G_AKA")
servingNetworkName	ServingNetworkName	M	1	See 3GPP TS 33.501 [6] subclause 6.1.1.4

6.3.6.2.8 Type: AuthenticationVector

Table 6.3.6.2.8-1: Definition of type AuthenticationVector as a list of alternatives

Data type	Cardinality	Description
AvEapAkaPrime	1	
Av5GHeAka	1	

6.3.6.3 Simple data types and enumerations

6.3.6.3.1 Introduction

This subclause defines simple data types and enumerations that can be referenced from data structures defined in the previous subclauses.

6.3.6.3.2 Simple data types

The simple data types defined in table 6.3.6.3.2-1 shall be supported.

Table 6.3.6.3.2-1: Simple data types

Type Name	Type Definition	Description
Authn	string	pattern: "[A-Fa-f0-9]{32}"
Auts	string	pattern: "[A-Fa-f0-9]{28}"
CkPrime	string	pattern: "[A-Fa-f0-9]{32}"
IkPrime	string	pattern: "[A-Fa-f0-9]{32}"
Kausf	string	pattern: "[A-Fa-f0-9]{64}"
Rand	string	pattern: "[A-Fa-f0-9]{32}"
ServingNetworkName	string	See 3GPP TS 33.501 [6] subclause 6.1.1.3
Success	boolean	true indicates success, false indicates no success
Xres	string	pattern: "[A-Fa-f0-9]{8,32}"
XresStar	string	pattern: "[A-Fa-f0-9]{32}"

6.3.6.3.3 Enumeration: AuthType

Table 6.3.6.3.3-1: Enumeration AuthType

Enumeration value	Description
"EAP_AKA_PRIME"	EAP-AKA'
"5G_AKA"	5G AKA
"EAP_TLS"	EAP-TLS. See NOTE
NOTE: EAP-TLS is described in the Informative Annex B of 3GPP TS 33.501 [6] and is not mandatory to support.	

6.3.6.3.4 Enumeration: AvType

Table 6.3.6.3.4-1: Enumeration AvType

Enumeration value	Description
"5G_HE_AKA"	
"EAP_AKA_PRIME"	

6.3.7 Error Handling

6.3.7.1 General

HTTP error handling shall be supported as specified in subclause 5.2.4 of 3GPP TS 29.500 [4].

6.3.7.2 Protocol Errors

Protocol errors handling shall be supported as specified in subclause 5.2.7 of 3GPP TS 29.500 [4].

6.3.7.3 Application Errors

The common application errors defined in the Table 5.2.7.2-1 in 3GPP TS 29.500 [4] may also be used for the Nudm_UEAuthentication service. The following application errors listed in Table 6.3.7.3-1 are specific for the Nudm_UEAuthentication service.

Table 6.3.7.3-1: Application errors

Application Error	HTTP status code	Description
AUTHENTICATION_REJECTED	403 Forbidden	The user is cannot be authenticated with this authentication method e.g. only SIM data available
SERVING_NETWORK_NOT_AUTHORIZED	403 Forbidden	The requesting network is not authorized to request UE authentication information.
USER_NOT_FOUND	404 Not Found	The user does not exist in the HPLMN
UNSUPPORTED_PROTECTION_SCHEME	501 Not implemented	The received protection scheme is not supported by HPLMN
INVALID_HN_PUBLIC_KEY_IDENTIFIER	403 Forbidden	Invalid HN public key identifier received
INVALID_SCHEME_OUTPUT	403 Forbidden	SUCI cannot be decrypted with received data

6.3.8 Feature Negotiation

The optional features in table 6.3.8-1 are defined for the Nudm_UEAU API. They shall be negotiated using the extensibility mechanism defined in subclause 6.6 of 3GPP TS 29.500 [4].

Table 6.3.8-1: Supported Features

Feature number	Feature Name	Description

6.3.9 Security

As indicated in 3GPP TS 33.501 [6] and 3GPP TS 29.500 [4], the access to the Nudm_UEAU API may be authorized by means of the OAuth2 protocol (see IETF RFC 6749 [18]), based on local configuration, using the "Client Credentials" authorization grant, where the NRF (see 3GPP TS 29.510 [19]) plays the role of the authorization server.

If OAuth2 is used, an NF Service Consumer, prior to consuming services offered by the Nudm_UEAU API, shall obtain a "token" from the authorization server, by invoking the Access Token Request service, as described in 3GPP TS 29.510 [19], subclause 5.4.2.2.

NOTE: When multiple NRFs are deployed in a network, the NRF used as authorization server is the same NRF that the NF Service Consumer used for discovering the Nudm_UEAU service.

The Nudm_UEAU API defines a single scope "nudm-ueau" for OAuth2 authorization (as specified in 3GPP TS 33.501 [6]) for the entire API, and it does not define any additional scopes at resource or operation level.

6.4 Nudm_EventExposure Service API

6.4.1 API URI

URIs of this API shall have the following root:

```
{apiRoot}/{apiName}/{apiVersion}/
```

where "apiRoot" is defined in subclause 4.4.1 of 3GPP TS 29.501 [5], the "apiName" shall be set to "nudm-ee" and the "apiVersion" shall be set to "v1" for the current version of this specification.

6.4.2 Usage of HTTP

6.4.2.1 General

HTTP/2, as defined in IETF RFC 7540 [13], shall be used as specified in clause 5 of 3GPP TS 29.500 [4].

HTTP/2 shall be transported as specified in subclause 5.3 of 3GPP TS 29.500 [4].

HTTP messages and bodies for the Nudm_EE service shall comply with the OpenAPI [14] specification contained in Annex A5.

6.4.2.2 HTTP standard headers

6.4.2.2.1 General

The usage of HTTP standard headers shall be supported as specified in subclause 5.2.2 of 3GPP TS 29.500 [4].

6.4.2.2.2 Content type

The following content types shall be supported:

JSON, as defined in IETF RFC 8259 [15], signalled by the content type "application/json".

The Problem Details JSON Object (IETF RFC 7807 [16]) signalled by the content type "application/problem+json"

6.4.2.3 HTTP custom headers

6.4.2.3.1 General

The usage of HTTP custom headers shall be supported as specified in subclause 5.2.3 of 3GPP TS 29.500 [4].

6.4.3 Resources

6.4.3.1 Overview

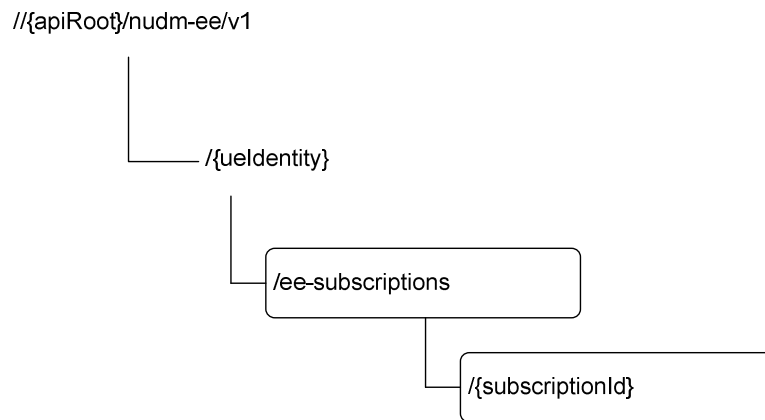

Figure 6.4.3.1-1: Resource URI structure of the Nudm_EE API

Table 6.4.3.1-1 provides an overview of the resources and applicable HTTP methods.

Table 6.4.3.1-1: Resources and methods overview

Resource name (Archetype)	Resource URI	HTTP method or custom operation	Description
EeSubscriptions (Collection)	<code>/{ueIdentity}/ee-subscriptions</code>	POST	Create a subscription
Individual subscription (Document)	<code>/{ueIdentity}/ee-subscriptions/{subscriptionId}</code>	DELETE	Delete the subscription identified by <code>{subscriptionId}</code> , i.e. unsubscribe

6.4.3.2 Resource: EeSubscriptions

6.4.3.2.1 Description

This resource is used to represent subscriptions to notifications.

6.4.3.2.2 Resource Definition

Resource URI: `{apiRoot}/nudm-ee/v1/{ueIdentity}/ee-subscriptions`

This resource shall support the resource URI variables defined in table 6.4.3.2.2-1.

Table 6.4.3.2.2-1: Resource URI variables for this resource

Name	Definition
apiRoot	See subclause 6.4.1
uelidentity	<p>Represents a single UE or a group of UEs or any UE.</p> <ul style="list-style-type: none"> - If representing a single UE, this parameter shall contain the Generic Public Subscription Identifier (see 3GPP TS 23.501 [2] subclause 5.9.8) pattern: "<code>^(msisdn-[0-9]{5,15} extid-[^@]+@[^@]+.+)\$</code>" - If representing a group of UEs, this parameter shall contain the External GroupId. pattern: "<code>^extgroupid-[^@]+@[^@]+\$</code>" - If representing any UE, this parameter shall contain "anyUE". pattern: "<code>^anyUES\$</code>"

6.4.3.2.3 Resource Standard Methods

6.4.3.2.3.1 POST

This method shall support the URI query parameters specified in table 6.4.3.2.3.1-1.

Table 6.4.3.2.3.1-1: URI query parameters supported by the POST method on this resource

Name	Data type	P	Cardinality	Description
n/a				

This method shall support the request data structures specified in table 6.4.3.2.3.1-2 and the response data structures and response codes specified in table 6.4.3.2.3.1-3.

Table 6.4.3.2.3.1-2: Data structures supported by the POST Request Body on this resource

Data type	P	Cardinality	Description
EeSubscription	M	1	The subscription that is to be created

Table 6.4.3.2.3.1-3: Data structures supported by the POST Response Body on this resource

Data type	P	Cardinality	Response codes	Description
CreatedEeSubscription	M	1	201 Created	<p>Upon success, a response body containing a representation of the created Individual subscription resource shall be returned.</p> <p>The HTTP response shall include a "Location" HTTP header that contains the resource URI of the created resource. When stateless UDM is deployed, the stateless UDM may use an FQDN identifying the UDM group to which the UDM belongs as the host part of the resource URI.</p>
ProblemDetails	M	1	403 Forbidden	<p>The "cause" attribute shall be set to the following application error: - <code>MONITORING_NOT_ALLOWED</code></p>
ProblemDetails	M	1	404 Not Found	<p>The "cause" attribute shall be set to the following application error: - <code>USER_NOT_FOUND</code></p>
ProblemDetails	M	1	501 Not Implemented	<p>The "cause" attribute shall be set to one of the following application errors: - <code>UNSUPPORTED_MONITORING_EVENT_TYPE</code> - <code>UNSUPPORTED_MONITORING_REPORT_OPTIONS</code></p>

NOTE: In addition common data structures as listed in table 6.4.7-1 are supported.

NOTE: In the scenario of stateless UDM deployment, it is assumed that stateless UDMs are organized into several UDM groups, and for each UDM group an FQDN can be allocated.

6.4.3.3 Resource: Individual subscription

6.4.3.3.1 Resource Definition

Resource URI: {apiRoot}/nudm-ee/v1/{ueIdentity}/ee-subscriptions/{subscriptionId}

This resource shall support the resource URI variables defined in table 6.4.3.3.1-1.

Table 6.4.3.3.1-1: Resource URI variables for this resource

Name	Definition
apiRoot	See subclause 6.1.1
ueIdentity	<p>Represents a single UE or a group of UEs or any UE.</p> <ul style="list-style-type: none"> - If representing a single UE, this parameter shall contain the Generic Public Subscription Identifier (see 3GPP TS 23.501 [2] subclause 5.9.8) pattern: "[^](msisdn-[0-9]{5,15} extid-[[^]@]+@[[^]@]+ .+) \$" - If representing a group of UEs, this parameter shall contain the External GroupId. pattern: "[^]extgroupid-[[^]@]+@[[^]@]+ \$" - If representing any UE, this parameter shall contain "anyUE". pattern: "[^]anyUES "
subscriptionId	The subscriptionId identifies an individual subscription to notifications. The value is allocated by the UDM during creation of the Subscription resource.

6.4.3.3.2 Resource Standard Methods

6.4.3.3.2.1 DELETE

This method shall support the URI query parameters specified in table 6.4.3.3.2.1-1.

Table 6.4.3.3.2.1-1: URI query parameters supported by the DELETE method on this resource

Name	Data type	P	Cardinality	Description
n/a				

This method shall support the request data structures specified in table 6.4.3.3.2.1-2 and the response data structures and response codes specified in table 6.4.3.3.2.1-3.

Table 6.4.3.3.2.1-2: Data structures supported by the Delete Request Body on this resource

Data type	P	Cardinality	Description
n/a			The request body shall be empty.

Table 6.4.3.3.2.1-3: Data structures supported by the DELETE Response Body on this resource

Data type	P	Cardinality	Response codes	Description
n/a			204 No Content	Upon success, an empty response body shall be returned.

NOTE: In addition common data structures as listed in table 6.4.7-1 are supported.

6.4.4 Custom Operations without associated resources

In this release of this specification, no custom operations without associated resources are defined for the Nudm_EventExposure Service.

6.4.5 Notifications

6.4.5.1 General

This subclause will specify the use of notifications and corresponding protocol details if required for the specific service. When notifications are supported by the API, it will include a reference to the general description of notifications support over the 5G SBIs specified in TS 29.500 / TS 29.501.

6.4.5.2 Event Occurrence Notification

The POST method shall be used for Event Occurrence Notifications and the URI shall be as provided during the subscription procedure.

Resource URI: {callbackReference}

Support of URI query parameters is specified in table 6.4.5.2-1.

Table 6.4.5.2-1: URI query parameters supported by the POST method

Name	Data type	P	Cardinality	Description
n/a				

Support of request data structures is specified in table 6.4.5.2-2 and of response data structures and response codes is specified in table 6.4.5.2-3.

Table 6.4.5.2-2: Data structures supported by the POST Request Body

Data type	P	Cardinality	Description
array(MonitoringReport)	M	1..N	A list of MonitoringReports each of which contains information regarding the occurred event

Table 6.4.5.2-3: Data structures supported by the POST Response Body

Data type	P	Cardinality	Response codes	Description
n/a			204 No Content	Upon success, an empty response body shall be returned.
ProblemDetails	M	1	404 Not Found	The "cause" attribute shall be set to the following application error: - CONTEXT_NOT_FOUND
NOTE: In addition common data structures as listed in table 6.1.7-1 are supported.				

6.4.6 Data Model

6.4.6.1 General

This subclause specifies the application data model supported by the API.

Table 6.4.6.2-1 specifies the data types defined for the Nudm_EE service API.

Table 6.4.6.1-1: Nudm_EE specific Data Types

Data type	Section defined	Description
EeSubscription	6.4.6.2.2	A subscription to Notifications
MonitoringConfiguration	6.4.6.2.3	Monitoring Configuration
MonitoringReport	6.4.6.2.4	Monitoring Report
Report	6.4.6.2.5	
ReportingOptions	6.4.6.2.6	
ChangeOfSupiPeiAssociationReport	6.4.6.2.7	
RoamingStatusReport	6.4.6.2.8	
CreatedEeSubscription	6.4.6.2.9	
LocationReportingConfiguration	6.4.6.2.10	

Table 6.4.6.1-2 specifies data types re-used by the Nudm_EE service API from other specifications, including a reference to their respective specifications and when needed, a short description of their use within the Nudm_EE service API.

Table 6.4.6.1-2: Nudm_EE re-used Data Types

Data type	Reference	Comments
Uri	3GPP TS 29.571 [7]	Uniform Resource Identifier
SupportedFeatures	3GPP TS 29.571 [7]	see 3GPP TS 29.500 [4] subclause 6.6
DateTime	3GPP TS 29.571 [7]	
Pei	3GPP TS 29.571 [7]	
PlmnId	3GPP TS 29.571 [7]	
Gpsi	3GPP TS 29.571 [7]	

6.4.6.2 Structured data types

6.4.6.2.1 Introduction

This subclause defines the structures to be used in resource representations.

6.4.6.2.2 Type: EeSubscription

Table 6.4.6.2.2-1: Definition of type EeSubscription

Attribute name	Data type	P	Cardinality	Description
callbackReference	Uri	M	1	URI provided by the NF service consumer to receive notifications
monitoringConfigurations	map(Monitoring Configuration)	M	1..N	A map (list of key-value pairs where referenceld converted from integer to string serves as key; see subclause 6.4.6.3.2) of MonitoringConfigurations; see subclause 6.4.6.2.3
reportingOptions	ReportingOptions	O	0..1	This IE may be included if the NF service consumer wants to describe how the reports of the event to be generated.
supportedFeatures	SupportedFeatures	O	0..1	See subclause 6.4.8

6.4.6.2.3 Type: MonitoringConfiguration

Table 6.4.6.2.3-1: Definition of type MonitoringConfiguration

Attribute name	Data type	P	Cardinality	Description
eventType	EventType	M	1	String; see subclause 6.4.6.3.3
immediateFlag	boolean	O	0..1	Indicates if an immediate event report in the subscription response indicating current value / status of the event is required or not. If the flag is not present then immediate reporting shall not be done.
locationReportingConfiguration	LocationReportingConfiguration	C	0..1	shall be present if eventType is "LOCATION_REPORTING"

6.4.6.2.4 Type: MonitoringReport

Table 6.4.6.2.4-1: Definition of type MonitoringReport

Attribute name	Data type	P	Cardinality	Description
referenceId	ReferenceId	M	1	
eventType	EventType	M	1	String; see subclause 6.4.6.3.3 only the following values are allowed: "UE_REACHABILITY_FOR_SMS" "CHANGE_OF_SUPI_PEI_ASSOCIATION" "ROAMING_STATUS"
report	Report	C	0..1	Shall be present if eventType is "CHANGE_OF_SUPI_PEI_ASSOCIATION" or "ROAMING_STATUS"
gpsi	Gpsi	C	0..1	shall be present if the report is associated to exposure subscriptions for a group of UEs or any UE.
timeStamp	DateTime	M	1	Point in time at which the event occurred

6.4.6.2.5 Type: Report

Table 6.4.6.2.5-1: Definition of type Report as a list of alternatives

Data type	Cardinality	Description
ChangeOfSupiPeiAssociationReport	1	
RoamingStatusReport	1	

6.4.6.2.6 Type: ReportingOptions

Table 6.4.6.2.6-1: Definition of type ReportingOptions

Attribute name	Data type	P	Cardinality	Description
maxNumOfReports	MaxNumOfReports	O	0..1	Maximum number of reports. If the event subscription is for a group of UEs, this parameter shall be applied to each individual member UE of the group.
expiry	DateTime	C	0..1	This IE shall be included in an event subscription response, if, based on operator policy, the UDM needs to include an expiry time, and may be included in an event subscription request. When present, this IE shall represent the time at which monitoring shall cease and the subscription becomes invalid. If the maxNumOfReports included in an event subscription response is 1 and if an event report is included in the subscription response then the value of the expiry included in the response shall be an immediate timestamp.

6.4.6.2.7 Type: ChangeOfSupiPeiAssociationReport

Table 6.4.6.2.7-1: Definition of type ChangeOfSupiPeiAssociationReport

Attribute name	Data type	P	Cardinality	Description
newPei	Pei	M	1	the new PEI

6.4.6.2.8 Type: RoamingStatusReport

Table 6.4.6.2.8-1: Definition of type RoamingStatusReport

Attribute name	Data type	P	Cardinality	Description
roaming	boolean	M	1	True: The new serving PLMN is different from the HPLMN; False: The new serving PLMN is the HPLMN
newServingPlmn	PlmnlId	M	1	the new Serving PLMN

6.4.6.2.9 Type: CreatedEeSubscription

Table 6.4.6.2.9-1: Definition of type CreatedEeSubscription

Attribute name	Data type	P	Cardinality	Description
eeSubscription	EeSubscription	M	1	This IE shall contain the representation of the created event subscription.
numberOfUes	UInteger	C	0..1	This IE shall be included if the event subscription is for a group of UEs. When present, this IE shall represent the number of UEs in the group.
eventReports	array(Monitoring Report)	O	1..N	This IE when present, shall contain the status of events that are requested for immediate reporting as well, if those events are available at the time of subscription.

6.4.6.2.10 Type: LocationReportingConfiguration

Table 6.4.6.2.10-1: Definition of type LocationReportingConfiguration

Attribute name	Data type	P	Cardinality	Description
currentLocation	boolean	M	1	When true: Indicates that current location is requested. When false: Indicates that last known location is requested.
oneTime	boolean	C	0..1	When true: Indicates that a single report is requested. When false or absent: Indicates that continuous reporting is requested. Shall not be absent or set to false when currentLocation is false.
accuracy	LocationAccuracy	C	0..1	Indicates whether Cell-level or TA-level accuracy is requested. Shall be present if continuous reporting is requested

6.4.6.3 Simple data types and enumerations

6.4.6.3.1 Introduction

This subclause defines simple data types and enumerations that can be referenced from data structures defined in the previous subclauses.

6.4.6.3.2 Simple data types

The simple data types defined in table 6.4.6.3.2-1 shall be supported.

Table 6.4.6.3.2-1: Simple data types

Type Name	Type Definition	Description
MaxNumOfReports	integer	Maximum number of reports. Minimum: 1
Referenceld	integer	Referenceld is used as key in a map of MonitoringConfigurations; see subclause 6.4.6.2.2.

6.4.6.3.3 Enumeration: EventType

Table 6.4.6.3.3-1: Enumeration EventType

Enumeration value	Description
"LOSS_OF_CONNECTIVITY"	Loss of connectivity
"UE_REACHABILITY_FOR_DATA"	UE reachability for data
"UE_REACHABILITY_FOR_SMS"	UE reachability for SMS
"LOCATION_REPORTING"	Location Reporting
"CHANGE_OF_SUPI_PEI_ASSOCIATION"	Change of SUPI-PEI association
"ROAMING_STATUS"	Roaming Status
"COMMUNICATION_FAILURE"	Communication Failure
"AVAILABILITY_AFTER_DNN_FAILURE"	Availability after DNN failure

6.4.6.3.4 Enumeration: LocationAccuracy

Table 6.4.6.3.4-1: Enumeration LocationAccuracy

Enumeration value	Description
"CELL_LEVEL"	change of cell shall be reported
"TA_LEVEL"	change of TA shall be reported

6.4.7 Error Handling

6.4.7.1 General

HTTP error handling shall be supported as specified in subclause 5.2.4 of 3GPP TS 29.500 [4].

6.4.7.2 Protocol Errors

Protocol errors handling shall be supported as specified in subclause 5.2.7 of 3GPP TS 29.500 [4].

6.4.7.3 Application Errors

The common application errors defined in the Table 5.2.7.2-1 in 3GPP TS 29.500 [4] may also be used for the Nudm_EventExposure service. The following application errors listed in Table 6.4.7.3-1 are specific for the Nudm_EventExposure service.

Table 6.4.7.3-1: Application errors

Application Error	HTTP status code	Description
MONITORING_NOT_ALLOWED	403 Forbidden	The subscriber does not have the necessary subscription for monitoring with the requested Event Type.
USER_NOT_FOUND	404 Not Found	The user does not exist
CONTEXT_NOT_FOUND	404 Not Found	It is used when no corresponding context exists.
UNSUPPORTED_MONITORING_EVENT_TYPE	501 Not Implemented	The monitoring configuration contains unsupported event type.
UNSUPPORTED_MONITORING_REPORT_OPTIONS	501 Not Implemented	The monitoring configuration contains unsupported report options.

6.4.8 Feature Negotiation

The optional features in table 6.4.8-1 are defined for the Nudm_EE API. They shall be negotiated using the extensibility mechanism defined in subclause 6.6 of 3GPP TS 29.500 [4].

Table 6.4.8-1: Supported Features

Feature number	Feature Name	Description

6.4.9 Security

As indicated in 3GPP TS 33.501 [6] and 3GPP TS 29.500 [4], the access to the Nudm_EE API may be authorized by means of the OAuth2 protocol (see IETF RFC 6749 [18]), based on local configuration, using the "Client Credentials" authorization grant, where the NRF (see 3GPP TS 29.510 [19]) plays the role of the authorization server.

If OAuth2 is used, an NF Service Consumer, prior to consuming services offered by the Nudm_EE API, shall obtain a "token" from the authorization server, by invoking the Access Token Request service, as described in 3GPP TS 29.510 [19], subclause 5.4.2.2.

NOTE: When multiple NRFs are deployed in a network, the NRF used as authorization server is the same NRF that the NF Service Consumer used for discovering the Nudm_EE service.

The Nudm_EE API defines a single scope "nudm-ee" for OAuth2 authorization (as specified in 3GPP TS 33.501 [6]) for the entire API, and it does not define any additional scopes at resource or operation level.

6.5 Nudm_ParameterProvision Service API

6.5.1 API URI

URIs of this API shall have the following root:

```
{apiRoot}/{apiName}/{apiVersion}/
```

where "apiRoot" is defined in subclause 4.4.1 of 3GPP TS 29.501 [5], the "apiName" shall be set to "nudm-pp" and the "apiVersion" shall be set to "v1" for the current version of this specification.

6.5.2 Usage of HTTP

6.5.2.1 General

HTTP/2, as defined in IETF RFC 7540 [13], shall be used as specified in clause 5 of 3GPP TS 29.500 [4].

HTTP/2 shall be transported as specified in subclause 5.3 of 3GPP TS 29.500 [4].

HTTP messages and bodies for the Nudm_PP service shall comply with the OpenAPI [14] specification contained in Annex A6.

6.5.2.2 HTTP standard headers

6.5.2.2.1 General

The usage of HTTP standard headers shall be supported as specified in subclause 5.2.2 of 3GPP TS 29.500 [4].

6.5.2.2.2 Content type

The following content types shall be supported:

JSON, as defined in IETF RFC 8259 [15], signalled by the content type "application/json".

The Problem Details JSON Object (IETF RFC 7807 [16]) signalled by the content type "application/problem+json"

JSON Merge Patch, as defined in IETF RFC 7396 [17], signalled by the content type "application/merge-patch+json"

6.5.2.3 HTTP custom headers

6.5.2.3.1 General

The usage of HTTP custom headers shall be supported as specified in subclause 5.2.3 of 3GPP TS 29.500 [4].

6.5.3 Resources

6.5.3.1 Overview

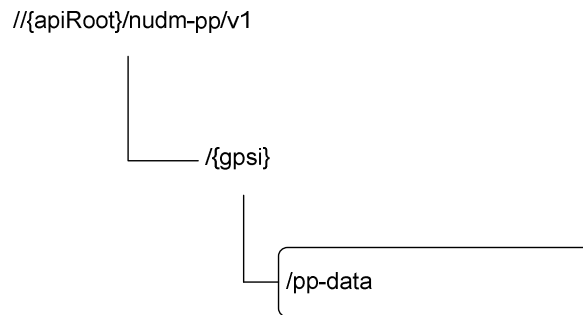

Figure 6.5.3.1-1: Resource URI structure of the Nudm_PP API

Table 6.5.3.1-1 provides an overview of the resources and applicable HTTP methods.

Table 6.5.3.1-1: Resources and methods overview

Resource name	Resource URI	HTTP method or custom operation	Description
PpData	//gpsi}/pp-data	PATCH	Modify the UE's modifiable subscription data

6.5.3.2 Resource: PpData

6.5.3.2.1 Description

This resource is used to represent Parameter Provisioning Data.

6.5.3.2.2 Resource Definition

Resource URI: {apiRoot}/nudm-pp/v1/{gpsi}/pp-data

This resource shall support the resource URI variables defined in table 6.5.3.2.2-1.

Table 6.5.3.2.2-1: Resource URI variables for this resource

Name	Definition
apiRoot	See subclause 6.5.1
gpsi	Represents the Generic Public Subscription Identifier (see 3GPP TS 23.501 [2] subclause 5.9.8) pattern: "(msisdn-[0-9]{5,15} extid-[^@]+@[^@]+.+)"

6.5.3.2.3 Resource Standard Methods

6.5.3.2.3.1 PATCH

This method shall support the URI query parameters specified in table 6.5.3.2.3.1-1.

Table 6.5.3.2.3.1-1: URI query parameters supported by the PATCH method on this resource

Name	Data type	P	Cardinality	Description
n/a				

This method shall support the request data structures specified in table 6.5.3.2.3.1-2 and the response data structures and response codes specified in table 6.5.3.2.3.1-3.

Table 6.5.3.2.3.1-2: Data structures supported by the PATCH Request Body on this resource

Data type	P	Cardinality	Description
PpData	M	1	The AMF registration for non 3GPP access is modified with the received information.

Table 6.5.3.2.3.1-3: Data structures supported by the PATCH Response Body on this resource

Data type	P	Cardinality	Response codes	Description
n/a			204 No Content	Upon success, an empty response body shall be returned
ProblemDetails	M	1	404 Not Found	The "cause" attribute shall be set to the following application error: - USER_NOT_FOUND
ProblemDetails	M	1	403 Forbidden	The "cause" attribute shall be set to the following application error: - MODIFICATION_NOT_ALLOWED
NOTE: In addition common data structures as listed in table 6.2.7-1 are supported.				

6.5.4 Custom Operations without associated resources

In this release of this specification, no custom operations without associated resources are defined for the Nudm_ParameterProvision Service.

6.5.5 Notifications

In this release of this specification, no notifications are defined for the Nudm_ParameterProvision Service.

6.5.6 Data Model

6.5.6.1 General

This subclause specifies the application data model supported by the API.

Table 6.5.6.1-1 specifies the data types defined for the Nudm_PP service API.

Table 6.5.6.1-1: Nudm_PP specific Data Types

Data type	Section defined	Description
PpData	6.5.6.2.2	Parameter Provision Data
CommunicationCharacteristics	6.5.6.2.3	Communication Characteristics
PpSubsRegTimer	6.5.6.2.4	
PpActiveTime	6.5.6.2.5	

Table 6.5.6.1-2 specifies data types re-used by the Nudm_PP service API from other APIs, including a reference and when needed, a short description of their use within the Nudm_PP service API.

Table 6.5.6.1-2: Nudm_PP re-used Data Types

Data type	Reference	Comments
DurationSec	3GPP TS 29.571 [7]	Time value in seconds
SupportedFeatures	3GPP TS 29.571 [7]	
NfInstanceId	3GPP TS 29.571 [7]	
ProblemDetails	3GPP TS 29.571 [7]	
Gpsi	3GPP TS 29.571 [7]	

6.5.6.2 Structured data types

6.5.6.2.1 Introduction

This subclause defines the structures to be used in resource representations.

6.5.6.2.2 Type: PpData

Table 6.5.6.2.2-1: Definition of type PpData

Attribute name	Data type	P	Cardinality	Description
supportedFeatures	SupportedFeatures	O	0..1	
communicationCharacteristics	CommunicationCharacteristics	O	0..1	communication characteristics

6.5.6.2.3 Type: CommunicationCharacteristics

Table 6.5.6.2.3-1: Definition of type CommunicationCharacteristics

Attribute name	Data type	P	Cardinality	Description
ppSubsRegTimer	PpSubsRegTimer	O	0..1	AF provisionedSubscribed periodic registration timer; nullable
ppActiveTime	PpActiveTime	O	0..1	AF provisioned active time; nullable
ppDIPacketCount	PpDIPacketCount	O	0..1	AF provisioned DL Buffering Suggested Packet Count; nullable

6.5.6.2.4 Type: PpSubsRegTimer

Table 6.5.6.2.4-1: Definition of type PpSubsRegTimer

Attribute name	Data type	P	Cardinality	Description
subsRegTimer	DurationSec	M	1	value in seconds
afInstanceId	NfInstanceId	M	1	NF Instance Id of the originating AF
referenceld	Referenceld	M	1	Transaction Reference ID

6.5.6.2.5 Type: PpActiveTime

Table 6.5.6.2.5-1: Definition of type PpActiveTime

Attribute name	Data type	P	Cardinality	Description
activeTime	DurationSec	M	1	value in seconds
afInstanceId	NfInstanceId	M	1	NF Instance Id of the originating AF
referenceld	Referenceld	M	1	Transaction Reference ID

6.5.6.3 Simple data types and enumerations

6.5.6.3.1 Introduction

This subclause defines simple data types and enumerations that can be referenced from data structures defined in the previous subclauses.

6.5.6.3.2 Simple data types

The simple data types defined in table 6.5.6.3.2-1 shall be supported.

Table 6.5.6.3.2-1: Simple data types

Type Name	Type Definition	Description
Referenceld	integer	
PpDIPacketCount	integer	nullable

6.5.6.3.3 Enumeration: <EnumType1>

Table 6.5.6.3.3-1: Enumeration <EnumType1>

Enumeration value	Description

6.5.7 Error Handling

6.5.7.1 General

HTTP error handling shall be supported as specified in subclause 5.2.4 of 3GPP TS 29.500 [4].

6.5.7.2 Protocol Errors

Protocol errors handling shall be supported as specified in subclause 5.2.7 of 3GPP TS 29.500 [4].

6.5.7.3 Application Errors

The common application errors defined in the Table 5.2.7.2-1 in 3GPP TS 29.500 [4] may also be used for the Nudm_ParameterProvision service. The following application errors listed in Table 6.5.7.3-1 are specific for the Nudm_ParameterProvision service.

The application errors defined for the Nudm_UECM service are listed in Table 6.5.7.3-1.

Table 6.5.7.3-1: Application errors

Application Error	HTTP status code	Description
MODIFICATION_NOT_ALLOWED	403 Forbidden	The subscriber does not have the necessary subscription for external parameter provisioning.
USER_NOT_FOUND	404 Not Found	The User does not exist.

6.5.8 Feature Negotiation

The optional features in table 6.5.8-1 are defined for the Nudm_PP API. They shall be negotiated using the extensibility mechanism defined in subclause 6.6 of 3GPP TS 29.500 [4].

Table 6.5.8-1: Supported Features

Feature number	Feature Name	Description

6.5.9 Security

As indicated in 3GPP TS 33.501 [6] and 3GPP TS 29.500 [4], the access to the Nudm_PP API may be authorized by means of the OAuth2 protocol (see IETF RFC 6749 [18]), based on local configuration, using the "Client Credentials" authorization grant, where the NRF (see 3GPP TS 29.510 [19]) plays the role of the authorization server.

If OAuth2 is used, an NF Service Consumer, prior to consuming services offered by the Nudm_PP API, shall obtain a "token" from the authorization server, by invoking the Access Token Request service, as described in 3GPP TS 29.510 [19], subclause 5.8.2.2.

NOTE: When multiple NRFs are deployed in a network, the NRF used as authorization server is the same NRF that the NF Service Consumer used for discovering the Nudm_PP service.

The Nudm_PP API defines a single scope "nudm-pp" for OAuth2 authorization (as specified in 3GPP TS 33.501 [6]) for the entire API, and it does not define any additional scopes at resource or operation level.

Annex A (normative): OpenAPI specification

A.1 General

This Annex specifies the formal definition of the Nudm Service API(s). It consists of OpenAPI 3.0.0 specifications, in YAML format.

A.2 Nudm_SDM API

```
openapi: 3.0.0

info:
  version: '1.0.0'
  title: 'Nudm_SDM'
  description: 'Nudm Subscriber Data Management Service'

externalDocs:
  description: 3GPP TS 29.503 Unified Data Management Services, version 15.2.1
  url: 'http://www.3gpp.org/ftp/Specs/archive/29_series/29.503/'

servers:
  - url: '{apiRoot}/nudm-sdm/v1'
    variables:
      apiRoot:
        default: https://example.com
        description: apiRoot as defined in subclause subclause 4.4 of 3GPP TS 29.501.

security:
  - oAuth2ClientCredentials:
    - nudm-sdm
  - {}

paths:
  /{supi}:
    get:
      summary: retrieve multiple data sets
      operationId: Get
      tags:
        - Retrieval of multiple data sets
      parameters:
        - name: supi
          in: path
          description: Identifier of the UE
          required: true
          schema:
            $ref: 'TS29571_CommonData.yaml#/components/schemas/Supi'
        - name: dataset-names
          in: query
          style: form
          explode: false
          description: List of dataset names
          required: true
          schema:
            $ref: '#/components/schemas/DatasetNames'
        - name: plmn-id
          in: query
          description: serving PLMN ID
          content:
            application/json:
              schema:
                $ref: 'TS29571_CommonData.yaml#/components/schemas/PlmnId'
        - name: supported-features
          in: query
          description: Supported Features
          schema:
            $ref: 'TS29571_CommonData.yaml#/components/schemas/SupportedFeatures'
        - name: If-None-Match
          in: header
          description: Validator for conditional requests, as described in RFC 7232, 3.2
          schema:
            type: string
        - name: If-Modified-Since
```

```

    in: header
    description: Validator for conditional requests, as described in RFC 7232, 3.3
    schema:
      type: string
  responses:
    '200':
      description: Expected response to a valid request
      content:
        application/json:
          schema:
            $ref: '#/components/schemas/SubscriptionDataSets'
      headers:
        Cache-Control:
          description: Cache-Control containing max-age, as described in RFC 7234, 5.2
          schema:
            type: string
        ETag:
          description: Entity Tag, containing a strong validator, as described in RFC 7232, 2.3
          schema:
            type: string
        Last-Modified:
          description: Timestamp for last modification of the resource, as described in RFC
7232, 2.2
          schema:
            type: string
    '400':
      $ref: 'TS29571_CommonData.yaml#/components/responses/400'
    '404':
      $ref: 'TS29571_CommonData.yaml#/components/responses/404'
    '500':
      $ref: 'TS29571_CommonData.yaml#/components/responses/500'
    '503':
      $ref: 'TS29571_CommonData.yaml#/components/responses/503'
    default:
      description: Unexpected error
  /{supi}/nssai:
    get:
      summary: retrieve a UE's subscribed NSSAI
      operationId: Get
      tags:
        - Slice Selection Subscription Data Retrieval
      parameters:
        - name: supi
          in: path
          description: Identifier of the UE
          required: true
          schema:
            $ref: 'TS29571_CommonData.yaml#/components/schemas/Supi'
        - name: supported-features
          in: query
          description: Supported Features
          schema:
            $ref: 'TS29571_CommonData.yaml#/components/schemas/SupportedFeatures'
        - name: plmn-id
          in: query
          description: serving PLMN ID
          content:
            application/json:
              schema:
                $ref: 'TS29571_CommonData.yaml#/components/schemas/PlmnId'
        - name: If-None-Match
          in: header
          description: Validator for conditional requests, as described in RFC 7232, 3.2
          schema:
            type: string
        - name: If-Modified-Since
          in: header
          description: Validator for conditional requests, as described in RFC 7232, 3.3
          schema:
            type: string
      responses:
        '200':
          description: Expected response to a valid request
          content:
            application/json:
              schema:
                $ref: '#/components/schemas/Nssai'
          headers:

```

```

    Cache-Control:
      description: Cache-Control containing max-age, as described in RFC 7234, 5.2
      schema:
        type: string
    ETag:
      description: Entity Tag, containing a strong validator, as described in RFC 7232, 2.3
      schema:
        type: string
    Last-Modified:
      description: Timestamp for last modification of the resource, as described in RFC
7232, 2.2
      schema:
        type: string
  '400':
    $ref: 'TS29571_CommonData.yaml#/components/responses/400'
  '404':
    $ref: 'TS29571_CommonData.yaml#/components/responses/404'
  '500':
    $ref: 'TS29571_CommonData.yaml#/components/responses/500'
  '503':
    $ref: 'TS29571_CommonData.yaml#/components/responses/503'
  default:
    description: Unexpected error
/{supi}/am-data:
  get:
    summary: retrieve a UE's Access and Mobility Subscription Data
    operationId: Get
    tags:
      - Access and Mobility Subscription Data Retrieval
    parameters:
      - name: supi
        in: path
        description: Identifier of the UE
        required: true
        schema:
          $ref: 'TS29571_CommonData.yaml#/components/schemas/Supi'
      - name: supported-features
        in: query
        description: Supported Features
        schema:
          $ref: 'TS29571_CommonData.yaml#/components/schemas/SupportedFeatures'
      - name: plmn-id
        in: query
        description: serving PLMN ID
        content:
          application/json:
            schema:
              $ref: 'TS29571_CommonData.yaml#/components/schemas/PlmnId'
      - name: If-None-Match
        in: header
        description: Validator for conditional requests, as described in RFC 7232, 3.2
        schema:
          type: string
      - name: If-Modified-Since
        in: header
        description: Validator for conditional requests, as described in RFC 7232, 3.3
        schema:
          type: string
    responses:
      '200':
        description: Expected response to a valid request
        content:
          application/json:
            schema:
              $ref: '#/components/schemas/AccessAndMobilitySubscriptionData'
        headers:
          Cache-Control:
            description: Cache-Control containing max-age, as described in RFC 7234, 5.2
            schema:
              type: string
          ETag:
            description: Entity Tag, containing a strong validator, as described in RFC 7232, 2.3
            schema:
              type: string
          Last-Modified:
            description: Timestamp for last modification of the resource, as described in RFC
7232, 2.2
            schema:

```

```

        type: string
    '400':
        $ref: 'TS29571_CommonData.yaml#/components/responses/400'
    '404':
        $ref: 'TS29571_CommonData.yaml#/components/responses/404'
    '500':
        $ref: 'TS29571_CommonData.yaml#/components/responses/500'
    '503':
        $ref: 'TS29571_CommonData.yaml#/components/responses/503'
    default:
        description: Unexpected error
/{supi}/smf-select-data:
  get:
    summary: retrieve a UE's SMF Selection Subscription Data
    operationId: Get
    tags:
      - SMF Selection Subscription Data Retrieval
    parameters:
      - name: supi
        in: path
        description: Identifier of the UE
        required: true
        schema:
          $ref: 'TS29571_CommonData.yaml#/components/schemas/Supi'
      - name: supported-features
        in: query
        description: Supported Features
        schema:
          $ref: 'TS29571_CommonData.yaml#/components/schemas/SupportedFeatures'
      - name: plmn-id
        in: query
        description: serving PLMN ID
        content:
          application/json:
            schema:
              $ref: 'TS29571_CommonData.yaml#/components/schemas/PlmnId'
      - name: If-None-Match
        in: header
        description: Validator for conditional requests, as described in RFC 7232, 3.2
        schema:
          type: string
      - name: If-Modified-Since
        in: header
        description: Validator for conditional requests, as described in RFC 7232, 3.3
        schema:
          type: string
    responses:
      '200':
        description: Expected response to a valid request
        content:
          application/json:
            schema:
              $ref: '#/components/schemas/SmfSelectionSubscriptionData'
        headers:
          Cache-Control:
            description: Cache-Control containing max-age, as described in RFC 7234, 5.2
            schema:
              type: string
          ETag:
            description: Entity Tag, containing a strong validator, as described in RFC 7232, 2.3
            schema:
              type: string
          Last-Modified:
            description: Timestamp for last modification of the resource, as described in RFC
7232, 2.2
            schema:
              type: string
      '400':
        $ref: 'TS29571_CommonData.yaml#/components/responses/400'
      '404':
        $ref: 'TS29571_CommonData.yaml#/components/responses/404'
      '500':
        $ref: 'TS29571_CommonData.yaml#/components/responses/500'
      '503':
        $ref: 'TS29571_CommonData.yaml#/components/responses/503'
    default:
        description: Unexpected error
/{supi}/ue-context-in-smf-data:

```

```

get:
  summary: retrieve a UE's UE Context In SMF Data
  operationId: Get
  tags:
    - UE Context In SMF Data Retrieval
  parameters:
    - name: supi
      in: path
      description: Identifier of the UE
      required: true
      schema:
        $ref: 'TS29571_CommonData.yaml#/components/schemas/Supi'
    - name: supported-features
      in: query
      description: Supported Features
      schema:
        $ref: 'TS29571_CommonData.yaml#/components/schemas/SupportedFeatures'
  responses:
    '200':
      description: Expected response to a valid request
      content:
        application/json:
          schema:
            $ref: '#/components/schemas/UeContextInSmfData'
    '400':
      $ref: 'TS29571_CommonData.yaml#/components/responses/400'
    '404':
      $ref: 'TS29571_CommonData.yaml#/components/responses/404'
    '500':
      $ref: 'TS29571_CommonData.yaml#/components/responses/500'
    '503':
      $ref: 'TS29571_CommonData.yaml#/components/responses/503'
    default:
      description: Unexpected error
/{supi}/ue-context-in-smsf-data:
  get:
    summary: retrieve a UE's UE Context In SMSF Data
    operationId: Get
    tags:
      - UE Context In SMSF Data Retrieval
    parameters:
      - name: supi
        in: path
        description: Identifier of the UE
        required: true
        schema:
          $ref: 'TS29571_CommonData.yaml#/components/schemas/Supi'
      - name: supported-features
        in: query
        description: Supported Features
        schema:
          $ref: 'TS29571_CommonData.yaml#/components/schemas/SupportedFeatures'
    responses:
      '200':
        description: Expected response to a valid request
        content:
          application/json:
            schema:
              $ref: '#/components/schemas/UeContextInSmsfData'
      '400':
        $ref: 'TS29571_CommonData.yaml#/components/responses/400'
      '404':
        $ref: 'TS29571_CommonData.yaml#/components/responses/404'
      '500':
        $ref: 'TS29571_CommonData.yaml#/components/responses/500'
      '503':
        $ref: 'TS29571_CommonData.yaml#/components/responses/503'
      default:
        description: Unexpected error
/{supi}/trace-data:
  get:
    summary: retrieve a UE's Trace Configuration Data
    operationId: Get
    tags:
      - Trace Configuration Data Retrieval
    parameters:
      - name: supi
        in: path

```

```

    description: Identifier of the UE
    required: true
    schema:
      $ref: 'TS29571_CommonData.yaml#/components/schemas/Supi'
  - name: supported-features
    in: query
    description: Supported Features
    schema:
      $ref: 'TS29571_CommonData.yaml#/components/schemas/SupportedFeatures'
  - name: plmn-id
    in: query
    description: serving PLMN ID
    content:
      application/json:
        schema:
          $ref: 'TS29571_CommonData.yaml#/components/schemas/PlmnId'
  - name: If-None-Match
    in: header
    description: Validator for conditional requests, as described in RFC 7232, 3.2
    schema:
      type: string
  - name: If-Modified-Since
    in: header
    description: Validator for conditional requests, as described in RFC 7232, 3.3
    schema:
      type: string
responses:
  '200':
    description: Expected response to a valid request
    content:
      application/json:
        schema:
          $ref: '#/components/schemas/TraceDataResponse'
  headers:
    Cache-Control:
      description: Cache-Control containing max-age, as described in RFC 7234, 5.2
      schema:
        type: string
    ETag:
      description: Entity Tag, containing a strong validator, as described in RFC 7232, 2.3
      schema:
        type: string
    Last-Modified:
      description: Timestamp for last modification of the resource, as described in RFC
7232, 2.2
      schema:
        type: string
  '400':
    $ref: 'TS29571_CommonData.yaml#/components/responses/400'
  '404':
    $ref: 'TS29571_CommonData.yaml#/components/responses/404'
  '500':
    $ref: 'TS29571_CommonData.yaml#/components/responses/500'
  '503':
    $ref: 'TS29571_CommonData.yaml#/components/responses/503'
  default:
    description: Unexpected error
/{supi}/sm-data:
  get:
    summary: retrieve a UE's Session Management Subscription Data
    operationId: Get
    tags:
      - Session Management Subscription Data Retrieval
    parameters:
      - name: supi
        in: path
        description: Identifier of the UE
        required: true
        schema:
          $ref: 'TS29571_CommonData.yaml#/components/schemas/Supi'
      - name: supported-features
        in: query
        description: Supported Features
        schema:
          $ref: 'TS29571_CommonData.yaml#/components/schemas/SupportedFeatures'
      - name: single-nssai
        in: query
        content:

```

```

    application/json:
      schema:
        $ref: 'TS29571_CommonData.yaml#/components/schemas/Snssai'
  - name: dnn
    in: query
    schema:
      $ref: 'TS29571_CommonData.yaml#/components/schemas/Dnn'
  - name: plmn-id
    in: query
    content:
      application/json:
        schema:
          $ref: 'TS29571_CommonData.yaml#/components/schemas/PlmnId'
  - name: If-None-Match
    in: header
    description: Validator for conditional requests, as described in RFC 7232, 3.2
    schema:
      type: string
  - name: If-Modified-Since
    in: header
    description: Validator for conditional requests, as described in RFC 7232, 3.3
    schema:
      type: string
responses:
  '200':
    description: Expected response to a valid request
    content:
      application/json:
        schema:
          type: array
          items:
            $ref: '#/components/schemas/SessionManagementSubscriptionData'
          minItems: 1
    headers:
      Cache-Control:
        description: Cache-Control containing max-age, as described in RFC 7234, 5.2
        schema:
          type: string
      ETag:
        description: Entity Tag, containing a strong validator, as described in RFC 7232, 2.3
        schema:
          type: string
      Last-Modified:
        description: Timestamp for last modification of the resource, as described in RFC
7232, 2.2
        schema:
          type: string
  '400':
    $ref: 'TS29571_CommonData.yaml#/components/responses/400'
  '404':
    $ref: 'TS29571_CommonData.yaml#/components/responses/404'
  '500':
    $ref: 'TS29571_CommonData.yaml#/components/responses/500'
  '503':
    $ref: 'TS29571_CommonData.yaml#/components/responses/503'
  default:
    description: Unexpected error
/{supi}/sms-data:
  get:
    summary: retrieve a UE's SMS Subscription Data
    operationId: Get
    tags:
      - SMS Subscription Data Retrieval
    parameters:
      - name: supi
        in: path
        description: Identifier of the UE
        required: true
        schema:
          $ref: 'TS29571_CommonData.yaml#/components/schemas/Supi'
      - name: supported-features
        in: query
        description: Supported Features
        schema:
          $ref: 'TS29571_CommonData.yaml#/components/schemas/SupportedFeatures'
      - name: plmn-id
        in: query
        content:

```

```

    application/json:
      schema:
        $ref: 'TS29571_CommonData.yaml#/components/schemas/PlmnId'
  - name: If-None-Match
    in: header
    description: Validator for conditional requests, as described in RFC 7232, 3.2
    schema:
      type: string
  - name: If-Modified-Since
    in: header
    description: Validator for conditional requests, as described in RFC 7232, 3.3
    schema:
      type: string
responses:
  '200':
    description: Expected response to a valid request
    content:
      application/json:
        schema:
          $ref: '#/components/schemas/SmsSubscriptionData'
    headers:
      Cache-Control:
        description: Cache-Control containing max-age, as described in RFC 7234, 5.2
        schema:
          type: string
      ETag:
        description: Entity Tag, containing a strong validator, as described in RFC 7232, 2.3
        schema:
          type: string
      Last-Modified:
        description: Timestamp for last modification of the resource, as described in RFC
7232, 2.2
        schema:
          type: string
  '400':
    $ref: 'TS29571_CommonData.yaml#/components/responses/400'
  '404':
    $ref: 'TS29571_CommonData.yaml#/components/responses/404'
  '500':
    $ref: 'TS29571_CommonData.yaml#/components/responses/500'
  '503':
    $ref: 'TS29571_CommonData.yaml#/components/responses/503'
  default:
    description: Unexpected error
/{supi}/sms-mng-data:
  get:
    summary: retrieve a UE's SMS Management Subscription Data
    operationId: Get
    tags:
      - SMS Management Subscription Data Retrieval
    parameters:
      - name: supi
        in: path
        description: Identifier of the UE
        required: true
        schema:
          $ref: 'TS29571_CommonData.yaml#/components/schemas/Supi'
      - name: supported-features
        in: query
        description: Supported Features
        schema:
          $ref: 'TS29571_CommonData.yaml#/components/schemas/SupportedFeatures'
      - name: plmn-id
        in: query
        content:
          application/json:
            schema:
              $ref: 'TS29571_CommonData.yaml#/components/schemas/PlmnId'
      - name: If-None-Match
        in: header
        description: Validator for conditional requests, as described in RFC 7232, 3.2
        schema:
          type: string
      - name: If-Modified-Since
        in: header
        description: Validator for conditional requests, as described in RFC 7232, 3.3
        schema:
          type: string

```



```

responses:
  '200':
    description: Expected response to a valid request
    content:
      application/json:
        schema:
          $ref: '#/components/schemas/SmsManagementSubscriptionData'
    headers:
      Cache-Control:
        description: Cache-Control containing max-age, as described in RFC 7234, 5.2
        schema:
          type: string
      ETag:
        description: Entity Tag, containing a strong validator, as described in RFC 7232, 2.3
        schema:
          type: string
      Last-Modified:
        description: Timestamp for last modification of the resource, as described in RFC
7232, 2.2
        schema:
          type: string
  '400':
    $ref: 'TS29571_CommonData.yaml#/components/responses/400'
  '404':
    $ref: 'TS29571_CommonData.yaml#/components/responses/404'
  '500':
    $ref: 'TS29571_CommonData.yaml#/components/responses/500'
  '503':
    $ref: 'TS29571_CommonData.yaml#/components/responses/503'
  default:
    description: Unexpected error
/{supi}/sdm-subscriptions:
  post:
    summary: subscribe to notifications
    operationId: Subscribe
    tags:
      - Subscription Creation
    parameters:
      - name: supi
        in: path
        description: SUPI of the user
        required: true
        schema:
          $ref: 'TS29571_CommonData.yaml#/components/schemas/Supi'
    requestBody:
      content:
        application/json:
          schema:
            $ref: '#/components/schemas/SdmSubscription'
      required: true
    responses:
      '201':
        description: Expected response to a valid request
        content:
          application/json:
            schema:
              $ref: '#/components/schemas/SdmSubscription'
        headers:
          Location:
            description: 'Contains the URI of the newly created resource, according to the
structure: {apiRoot}/nudm-sdm/v1/{supi}/sdm-subscriptions/{subscriptionId}'
            required: true
            schema:
              type: string
      '400':
        $ref: 'TS29571_CommonData.yaml#/components/responses/400'
      '404':
        $ref: 'TS29571_CommonData.yaml#/components/responses/404'
      '500':
        $ref: 'TS29571_CommonData.yaml#/components/responses/500'
      '501':
        $ref: 'TS29571_CommonData.yaml#/components/responses/501'
      '503':
        $ref: 'TS29571_CommonData.yaml#/components/responses/503'
      default:
        description: Unexpected error
    callbacks:
      datachangeNotification:

```

```

    '{request.body#/callbackReference}':
      post:
        requestBody:
          required: true
          content:
            application/json:
              schema:
                $ref: '#/components/schemas/ModificationNotification'
        responses:
          '204':
            description: Successful Notification response
          '307':
            description: Temporary Redirect
            content:
              application/problem+json:
                schema:
                  $ref: 'TS29571_CommonData.yaml#/components/schemas/ProblemDetails'
          '308':
            description: Permanent Redirect
            content:
              application/problem+json:
                schema:
                  $ref: 'TS29571_CommonData.yaml#/components/schemas/ProblemDetails'
          '400':
            $ref: 'TS29571_CommonData.yaml#/components/responses/400'
          '404':
            $ref: 'TS29571_CommonData.yaml#/components/responses/404'
          '500':
            $ref: 'TS29571_CommonData.yaml#/components/responses/500'
          '503':
            $ref: 'TS29571_CommonData.yaml#/components/responses/503'
          default:
            description: Unexpected error
  /{supi}/sdm-subscriptions/{subscriptionId}:
    delete:
      summary: unsubscribe from notifications
      operationId: Unsubscribe
      tags:
        - Subscription Deletion
      parameters:
        - name: supi
          in: path
          description: SUPI of the user
          required: true
          schema:
            $ref: 'TS29571_CommonData.yaml#/components/schemas/Supi'
        - name: subscriptionId
          in: path
          description: Id of the SDM Subscription
          required: true
          schema:
            type: string
      responses:
        '204':
          description: Successful response
        '400':
          $ref: 'TS29571_CommonData.yaml#/components/responses/400'
        '500':
          $ref: 'TS29571_CommonData.yaml#/components/responses/500'
        '503':
          $ref: 'TS29571_CommonData.yaml#/components/responses/503'
        default:
          description: Unexpected error
  /{gpsi}/id-translation-result:
    get:
      summary: retrieve a UE's SUPI
      operationId: Get
      tags:
        - GPSI to SUPI Translation
      parameters:
        - name: gpsi
          in: path
          description: Identifier of the UE
          required: true
          schema:
            $ref: 'TS29571_CommonData.yaml#/components/schemas/Gpsi'
        - name: supported-features
          in: query

```

```

    description: Supported Features
    schema:
      $ref: 'TS29571_CommonData.yaml#/components/schemas/SupportedFeatures'
  - name: If-None-Match
    in: header
    description: Validator for conditional requests, as described in RFC 7232, 3.2
    schema:
      type: string
  - name: If-Modified-Since
    in: header
    description: Validator for conditional requests, as described in RFC 7232, 3.3
    schema:
      type: string
responses:
  '200':
    description: Expected response to a valid request
    content:
      application/json:
        schema:
          $ref: '#/components/schemas/IdTranslationResult'
    headers:
      Cache-Control:
        description: Cache-Control containing max-age, as described in RFC 7234, 5.2
        schema:
          type: string
      ETag:
        description: Entity Tag, containing a strong validator, as described in RFC 7232, 2.3
        schema:
          type: string
      Last-Modified:
        description: Timestamp for last modification of the resource, as described in RFC
7232, 2.2
        schema:
          type: string
  '400':
    $ref: 'TS29571_CommonData.yaml#/components/responses/400'
  '404':
    $ref: 'TS29571_CommonData.yaml#/components/responses/404'
  '500':
    $ref: 'TS29571_CommonData.yaml#/components/responses/500'
  '503':
    $ref: 'TS29571_CommonData.yaml#/components/responses/503'
  default:
    description: Unexpected error
/{supi}/am-data/sor-ack:
  put:
    summary: Nudm_Sdm Info service operation
    operationId: Info
    tags:
      - Providing acknowledgement of Steering of Roaming
    parameters:
      - name: supi
        in: path
        description: Identifier of the UE
        required: true
        schema:
          $ref: 'TS29571_CommonData.yaml#/components/schemas/Supi'
    requestBody:
      content:
        application/json:
          schema:
            $ref: '#/components/schemas/AcknowledgeInfo'
    responses:
      '204':
        description: Successful acknowledgement
      '400':
        $ref: 'TS29571_CommonData.yaml#/components/responses/400'
      '500':
        $ref: 'TS29571_CommonData.yaml#/components/responses/500'
      '503':
        $ref: 'TS29571_CommonData.yaml#/components/responses/503'
      default:
        description: Unexpected error
/shared-data:
  get:
    summary: retrieve shared data
    operationId: GetSharedData
    tags:

```

```

- Retrieval of shared data
parameters:
- name: shared-data-ids
  in: query
  description: List of shared data ids
  required: true
  style: form
  explode: false
  schema:
    $ref: '#/components/schemas/SharedDataIds'
- name: supportedFeatures
  in: query
  description: Supported Features
  schema:
    $ref: 'TS29571_CommonData.yaml#/components/schemas/SupportedFeatures'
- name: If-None-Match
  in: header
  description: Validator for conditional requests, as described in RFC 7232, 3.2
  schema:
    type: string
- name: If-Modified-Since
  in: header
  description: Validator for conditional requests, as described in RFC 7232, 3.3
  schema:
    type: string
responses:
'200':
  description: Expected response to a valid request
  content:
    application/json:
      schema:
        type: array
        items:
          $ref: '#/components/schemas/SharedData'
        minItems: 1
  headers:
    Cache-Control:
      description: Cache-Control containing max-age, as described in RFC 7234, 5.2
      schema:
        type: string
    ETag:
      description: Entity Tag, containing a strong validator, as described in RFC 7232, 2.3
      schema:
        type: string
    Last-Modified:
      description: Timestamp for last modification of the resource, as described in RFC
7232, 2.2
      schema:
        type: string
'400':
  $ref: 'TS29571_CommonData.yaml#/components/responses/400'
'404':
  $ref: 'TS29571_CommonData.yaml#/components/responses/404'
'500':
  $ref: 'TS29571_CommonData.yaml#/components/responses/500'
'503':
  $ref: 'TS29571_CommonData.yaml#/components/responses/503'
default:
  description: Unexpected error
/shared-data-subscriptions:
post:
  summary: subscribe to notifications for shared data
  operationId: Subscribe to shared data
  tags:
  - Subscription Creation for shared data
  requestBody:
    content:
      application/json:
        schema:
          $ref: '#/components/schemas/SdmSubscription'
        required: true
  responses:
'201':
  description: Expected response to a valid request
  content:
    application/json:
      schema:
        $ref: '#/components/schemas/SdmSubscription'

```

```

    headers:
      Location:
        description: 'Contains the URI of the newly created resource, according to the
structure: {apiRoot}/nudm-sdm/v1/shared-data-subscriptions/{subscriptionId}'
        required: true
        schema:
          type: string
    '400':
      $ref: 'TS29571_CommonData.yaml#/components/responses/400'
    '404':
      $ref: 'TS29571_CommonData.yaml#/components/responses/404'
  default:
    description: Unexpected error
  callbacks:
    datachangeNotification:
      '{request.body#/callbackReference}':
        post:
          requestBody:
            required: true
            content:
              application/json:
                schema:
                  $ref: '#/components/schemas/ModificationNotification'
          responses:
            '204':
              description: Successful Notification response
            '400':
              $ref: 'TS29571_CommonData.yaml#/components/responses/400'
            '404':
              $ref: 'TS29571_CommonData.yaml#/components/responses/404'
            '500':
              $ref: 'TS29571_CommonData.yaml#/components/responses/500'
            '503':
              $ref: 'TS29571_CommonData.yaml#/components/responses/503'
          default:
            description: Unexpected error
/shared-data-subscriptions/{subscriptionId}:
  delete:
    summary: unsubscribe from notifications for shared data
    operationId: Unsubscribe for shared data
    tags:
      - Subscription Deletion for shared data
    parameters:
      - name: subscriptionId
        in: path
        description: Id of the Shared data Subscription
        required: true
        schema:
          type: string
    responses:
      '204':
        description: Successful response
      '400':
        $ref: 'TS29571_CommonData.yaml#/components/responses/400'
      '500':
        $ref: 'TS29571_CommonData.yaml#/components/responses/500'
      '503':
        $ref: 'TS29571_CommonData.yaml#/components/responses/503'
    default:
      description: Unexpected error

components:
  securitySchemes:
    oAuth2ClientCredentials:
      type: oauth2
      flows:
        clientCredentials:
          tokenUrl: '{nrfApiRoot}/oauth2/token'
          scopes:
            nudm-sdm: Access to the nudm-sdm API

schemas:

# COMPLEX TYPES:

DatasetNames:
  type: array
  items:

```

```

    $ref: '#/components/schemas/DataSetName'
  minItems: 2
  uniqueItems: true

SubscriptionDataSets:
  type: object
  properties:
    amData:
      $ref: '#/components/schemas/AccessAndMobilitySubscriptionData'
    smfSelData:
      $ref: '#/components/schemas/SmfSelectionSubscriptionData'
    uecSmfData:
      $ref: '#/components/schemas/UeContextInSmfData'
    uecSmsfData:
      $ref: '#/components/schemas/UeContextInSmsfData'
    smsSubsData:
      $ref: '#/components/schemas/SmsSubscriptionData'
    smData:
      type: array
      items:
        $ref: '#/components/schemas/SessionManagementSubscriptionData'
      minItems: 1
    traceData:
      $ref: 'TS29571_CommonData.yaml#/components/schemas/TraceData'
    smsMngData:
      $ref: '#/components/schemas/SmsManagementSubscriptionData'

UeContextInSmsfData:
  type: object
  properties:
    smsfInfo3GppAccess:
      $ref: '#/components/schemas/SmsfInfo'
    smsfInfoNon3GppAccess:
      $ref: '#/components/schemas/SmsfInfo'

SmsfInfo:
  type: object
  required:
    - smsfInstanceId
    - plmnId
  properties:
    smsfInstanceId:
      $ref: 'TS29571_CommonData.yaml#/components/schemas/NfInstanceId'
    plmnId:
      $ref: 'TS29571_CommonData.yaml#/components/schemas/PlmnId'

AccessAndMobilitySubscriptionData:
  type: object
  properties:
    supportedFeatures:
      $ref: 'TS29571_CommonData.yaml#/components/schemas/SupportedFeatures'
    gpsis:
      type: array
      items:
        $ref: 'TS29571_CommonData.yaml#/components/schemas/Gpsi'
    internalGroupIds:
      type: array
      items:
        $ref: 'TS29571_CommonData.yaml#/components/schemas/GroupId'
      minItems: 1
    subscribedUeAmbr:
      $ref: 'TS29571_CommonData.yaml#/components/schemas/AmbrRm'
    nssai:
      $ref: '#/components/schemas/Nssai'
    ratRestrictions:
      type: array
      items:
        $ref: 'TS29571_CommonData.yaml#/components/schemas/RatType'
    forbiddenAreas:
      type: array
      items:
        $ref: 'TS29571_CommonData.yaml#/components/schemas/Area'
    serviceAreaRestriction:
      $ref: 'TS29571_CommonData.yaml#/components/schemas/ServiceAreaRestriction'
    coreNetworkTypeRestrictions:
      type: array
      items:
        $ref: 'TS29571_CommonData.yaml#/components/schemas/CoreNetworkType'

```

```

rfspIndex:
  $ref: 'TS29571_CommonData.yaml#/components/schemas/RfspIndexRm'
subsRegTimer:
  $ref: 'TS29571_CommonData.yaml#/components/schemas/DurationSecRm'
ueUsageType:
  $ref: '#/components/schemas/UeUsageType'
mpsPriority:
  $ref: '#/components/schemas/MpsPriorityIndicator'
mcsPriority:
  $ref: '#/components/schemas/McsPriorityIndicator'
activeTime:
  $ref: 'TS29571_CommonData.yaml#/components/schemas/DurationSecRm'
dlPacketCount:
  $ref: '#/components/schemas/DlPacketCount'
sorInfo:
  $ref: '#/components/schemas/SorInfo'
micoAllowed:
  $ref: '#/components/schemas/MicoAllowed'
sharedAmDataIds:
  type: array
  items:
    $ref: '#/components/schemas/SharedDataId'
  minItems: 1
odbPacketServices:
  $ref: 'TS29571_CommonData.yaml#/components/schemas/OdbPacketServices'

SmfSelectionSubscriptionData:
  type: object
  properties:
    supportedFeatures:
      $ref: 'TS29571_CommonData.yaml#/components/schemas/SupportedFeatures'
    subscribedSnssaiInfos:
      type: object
      additionalProperties:
        $ref: '#/components/schemas/SnssaiInfo'
    sharedSnssaiInfosId:
      $ref: '#/components/schemas/SharedDataId'

SnssaiInfo:
  type: object
  required:
    - dnnInfos
  properties:
    dnnInfos:
      type: array
      items:
        $ref: '#/components/schemas/DnnInfo'
      minItems: 1

DnnInfo:
  type: object
  required:
    - dnn
  properties:
    dnn:
      $ref: 'TS29571_CommonData.yaml#/components/schemas/Dnn'
    defaultDnnIndicator:
      $ref: '#/components/schemas/DnnIndicator'
    lboRoamingAllowed:
      $ref: '#/components/schemas/LboRoamingAllowed'
    iwkEpsInd:
      $ref: '#/components/schemas/IwkEpsInd'
    ladnIndicator:
      $ref: '#/components/schemas/LadnIndicator'

Nssai:
  type: object
  required:
    - defaultSingleNssais
  properties:
    supportedFeatures:
      $ref: 'TS29571_CommonData.yaml#/components/schemas/SupportedFeatures'
    defaultSingleNssais:
      type: array
      items:
        $ref: 'TS29571_CommonData.yaml#/components/schemas/Snssai'
      minItems: 1

```

```

    singleNssais:
      type: array
      items:
        $ref: 'TS29571_CommonData.yaml#/components/schemas/Snssai'
      minItems: 1
    nullable: true

UeContextInSmfData:
  type: object
  properties:
    pduSessions:
      description: A map (list of key-value pairs where PduSessionId serves as key) of
PduSessions
      type: object
      additionalProperties:
        $ref: '#/components/schemas/PduSession'
      pgwInfo:
        type: array
        items:
          $ref: '#/components/schemas/PgwInfo'
        minItems: 1

PduSession:
  type: object
  required:
    - dnn
    - smfInstanceId
    - plmnId
  properties:
    dnn:
      $ref: 'TS29571_CommonData.yaml#/components/schemas/Dnn'
    smfInstanceId:
      $ref: 'TS29571_CommonData.yaml#/components/schemas/NfInstanceId'
    plmnId:
      $ref: 'TS29571_CommonData.yaml#/components/schemas/PlmnId'

PgwInfo:
  type: object
  required:
    - dnn
    - pgwFqdn
  properties:
    dnn:
      $ref: 'TS29571_CommonData.yaml#/components/schemas/Dnn'
    pgwFqdn:
      type: string
    plmnId:
      $ref: 'TS29571_CommonData.yaml#/components/schemas/PlmnId'

SessionManagementSubscriptionData:
  type: object
  required:
    - singleNssai
  properties:
    singleNssai:
      $ref: 'TS29571_CommonData.yaml#/components/schemas/Snssai'
    dnnConfigurations:
      description: A map (list of key-value pairs where Dnn serves as key) of DnnConfigurations
      type: object
      additionalProperties:
        $ref: '#/components/schemas/DnnConfiguration'
    internalGroupIds:
      type: array
      items:
        $ref: 'TS29571_CommonData.yaml#/components/schemas/GroupId'
      minItems: 1
    sharedDnnConfigurationsIds:
      $ref: '#/components/schemas/SharedDataId'

DnnConfiguration:
  type: object
  required:
    - pduSessionTypes
    - sscModes
  properties:
    pduSessionTypes:
      $ref: '#/components/schemas/PduSessionTypes'
    sscModes:

```



```

    $ref: '#/components/schemas/SscModes'
  iwKepsInd:
    $ref: '#/components/schemas/IwkEpsInd'
  ladnIndicator:
    $ref: '#/components/schemas/LadnIndicator'
  5gQosProfile:
    $ref: 'TS29571_CommonData.yaml#/components/schemas/SubscribedDefaultQos'
  sessionAmbr:
    $ref: 'TS29571_CommonData.yaml#/components/schemas/Ambr'
  3gppChargingCharacteristics:
    $ref: '#/components/schemas/3GppChargingCharacteristics'
  staticIpAddress:
    type: array
    items:
      $ref: '#/components/schemas/IpAddress'
    minItems: 1
    maxItems: 2
  upSecurity:
    $ref: 'TS29571_CommonData.yaml#/components/schemas/UpSecurity'

IpAddress:
  type: object
  oneOf:
    - required:
      - ipv4Address
    - required:
      - ipv6Address
    - required:
      - ipv6Prefix
  properties:
    ipv4Addr:
      $ref: 'TS29571_CommonData.yaml#/components/schemas/Ipv4Addr'
    ipv6Addr:
      $ref: 'TS29571_CommonData.yaml#/components/schemas/Ipv6Addr'
    ipv6Prefix:
      $ref: 'TS29571_CommonData.yaml#/components/schemas/Ipv6Prefix'

PduSessionTypes:
  type: object
  required:
    - defaultSessionType
  properties:
    defaultSessionType:
      $ref: 'TS29571_CommonData.yaml#/components/schemas/PduSessionType'
    allowedSessionTypes:
      type: array
      items:
        $ref: 'TS29571_CommonData.yaml#/components/schemas/PduSessionType'
      minItems: 1

SscModes:
  type: object
  required:
    - defaultSscMode
  properties:
    defaultSscMode:
      $ref: 'TS29571_CommonData.yaml#/components/schemas/SscMode'
    allowedSscModes:
      type: array
      items:
        $ref: 'TS29571_CommonData.yaml#/components/schemas/SscMode'
      minItems: 1
      maxItems: 2

SmsSubscriptionData:
  type: object
  properties:
    smsSubscribed:
      $ref: '#/components/schemas/SmsSubscribed'
    sharedSmsSubsDataId:
      $ref: '#/components/schemas/SharedDataIds'

SmsManagementSubscriptionData:
  type: object
  properties:
    supportedFeatures:
      $ref: 'TS29571_CommonData.yaml#/components/schemas/SupportedFeatures'
    mtSmsSubscribed:

```

```

    type: boolean
  mtSmsBarringAll:
    type: boolean
  mtSmsBarringRoaming:
    type: boolean
  moSmsSubscribed:
    type: boolean
  moSmsBarringAll:
    type: boolean
  moSmsBarringRoaming:
    type: boolean
  sharedSmsMngDataIds:
    type: array
    items:
      $ref: '#/components/schemas/SharedDataId'
    minItems: 1

SdmSubscription:
  type: object
  required:
    - nfInstanceId
    - callbackUri
    - monitoredResourceUri
  properties:
    nfInstanceId:
      $ref: 'TS29571_CommonData.yaml#/components/schemas/NfInstanceId'
    implicitUnsubscribe:
      type: boolean
    expires:
      $ref: 'TS29571_CommonData.yaml#/components/schemas/DateTime'
    callbackReference:
      $ref: 'TS29571_CommonData.yaml#/components/schemas/Uri'
    amfServiceName:
      $ref: 'TS29510_Nnrf_NFManagement.yaml#/components/schemas/ServiceName'
    monitoredResourceUris:
      type: array
      items:
        $ref: 'TS29571_CommonData.yaml#/components/schemas/Uri'
      minItems: 1
    singleNssai:
      $ref: 'TS29571_CommonData.yaml#/components/schemas/Snssai'
    dnn:
      $ref: 'TS29571_CommonData.yaml#/components/schemas/Dnn'

ModificationNotification:
  type: object
  required:
    - notifyItems
  properties:
    notifyItems:
      type: array
      items:
        $ref: 'TS29571_CommonData.yaml#/components/schemas/NotifyItem'
      minItems: 1

IdTranslationResult:
  type: object
  required:
    - supi
  properties:
    supportedFeatures:
      $ref: 'TS29571_CommonData.yaml#/components/schemas/SupportedFeatures'
    supi:
      $ref: 'TS29571_CommonData.yaml#/components/schemas/Supi'
    gpsi:
      $ref: 'TS29571_CommonData.yaml#/components/schemas/Gpsi'

AcknowledgeInfo:
  type: object
  properties:
    sorMacIue:
      $ref: 'TS29509_Nausf_SorProtection.yaml#/components/schemas/SorMac'
    securedPacket:
      $ref: '#/components/schemas/SecuredPacket'

SorInfo:
  type: object

```

```
properties:
  steeringContainer:
    $ref: '#/components/schemas/SteeringContainer'
  ackInd:
    $ref: 'TS29509_Nausf_SoRProtection.yaml#/components/schemas/AckInd'
  sorMacIausf:
    $ref: 'TS29509_Nausf_SoRProtection.yaml#/components/schemas/SorMac'
  countersor:
    $ref: 'TS29509_Nausf_SoRProtection.yaml#/components/schemas/CounterSor'
required:
- ackInd
- sorMacIausf
- countersor

SharedDataIds:
  type: array
  items:
    $ref: '#/components/schemas/SharedDataId'

SharedData:
  type: object
  required:
  - sharedDataId
  properties:
    sharedDataId:
      $ref: '#/components/schemas/SharedDataId'
    sharedAmData:
      $ref: '#/components/schemas/AccessAndMobilitySubscriptionData'
    sharedSmsSubsData:
      $ref: '#/components/schemas/SmsSubscriptionData'
    sharedSmsMngSubsData:
      $ref: '#/components/schemas/SmsManagementSubscriptionData'
    sharedDnnConfigurations:
      type: object
      additionalProperties:
        $ref: '#/components/schemas/DnnConfiguration'
    sharedTraceData:
      $ref: 'TS29571_CommonData.yaml#/components/schemas/TraceData'
    sharedSnssaiInfos:
      type: object
      additionalProperties:
        $ref: '#/components/schemas/SnssaiInfo'
    sharedAuthenticationSubscription:
      $ref:
'TS29505_Subscription_Data.yaml#/components/schemas/SharedAuthenticationSubscription'

TraceDataResponse:
  type: object
  properties:
    traceData:
      $ref: 'TS29571_CommonData.yaml#/components/schemas/TraceData'
    sharedTraceDataId:
      $ref: '#/components/schemas/SharedDataId'

SteeringContainer:
  oneOf:
  - type: array
    items:
      $ref: 'TS29509_Nausf_SoRProtection.yaml#/components/schemas/SteeringInfo'
    minItems: 1
  - $ref: '#/components/schemas/SecuredPacket'

# SIMPLE TYPES:

UeUsageType:
  type: integer

MpsPriorityIndicator:
  type: boolean

McsPriorityIndicator:
  type: boolean

DnnIndicator:
  type: boolean

LboRoamingAllowed:
```

```

    type: boolean

  LadmIndicator:
    type: boolean

  SmsSubscribed:
    type: boolean

  3GppChargingCharacteristics:
    type: string

  DlPacketCount:
    type: integer
    minimum: -1

  MicoAllowed:
    type: boolean

  SharedDataId:
    type: string
    pattern: '^[0-9]{5,6}-.+$$'

  IwkEpsInd:
    type: boolean

  SecuredPacket:
    type: string
    format: base64

# ENUMS:

  DataSetName:
    anyOf:
      - type: string
        enum:
          - AM
          - SMF_SEL
          - UEC_SMF
          - UEC_SMSF
          - SMS_SUB
          - SM
          - TRACE
          - SMS_MNG
      - type: string

```

A.3 Nudm_UECM API

openapi: 3.0.0

```

info:
  version: '1.0.0'
  title: 'Nudm_UECM'
  description: 'Nudm Context Management Service'

```

```

externalDocs:
  description: 3GPP TS 29.503 Unified Data Management Services, version 15.2.1
  url: 'http://www.3gpp.org/ftp/Specs/archive/29_series/29.503/'

```

```

servers:
  - url: '{apiRoot}/nudm-uecm/v1'
    variables:
      apiRoot:
        default: https://example.com
        description: apiRoot as defined in subclause subclause 4.4 of 3GPP TS 29.501.

```

```

security:
  - oAuth2ClientCredentials:
    - nudm-uecm
  - {}

```

```

paths:
  /{ueId}/registrations/amf-3gpp-access:
    put:
      summary: register as AMF for 3GPP access

```

```

operationId: Registration
tags:
  - AMF registration for 3GPP access
parameters:
  - name: ueId
    in: path
    description: Identifier of the UE
    required: true
    schema:
      $ref: 'TS29571_CommonData.yaml#/components/schemas/Supi'
requestBody:
  content:
    application/json:
      schema:
        $ref: '#/components/schemas/Amf3GppAccessRegistration'
      required: true
responses:
  '201':
    description: Created
    content:
      application/json:
        schema:
          $ref: '#/components/schemas/Amf3GppAccessRegistration'
    headers:
      Location:
        description: 'Contains the URI of the newly created resource, according to the
structure: {apiRoot}/nudm-uecm/v1/{ueId}/registrations/amf-3gpp-access'
        required: true
        schema:
          type: string
  '200':
    description: OK
    content:
      application/json:
        schema:
          $ref: '#/components/schemas/Amf3GppAccessRegistration'
  '204':
    description: No content
  '400':
    $ref: 'TS29571_CommonData.yaml#/components/responses/400'
  '403':
    $ref: 'TS29571_CommonData.yaml#/components/responses/403'
  '404':
    $ref: 'TS29571_CommonData.yaml#/components/responses/404'
  '500':
    $ref: 'TS29571_CommonData.yaml#/components/responses/500'
  '503':
    $ref: 'TS29571_CommonData.yaml#/components/responses/503'
default:
  description: Unexpected error
callbacks:
  deregistrationNotification:
    '{request.body#/deregCallbackUri}':
      post:
        requestBody:
          required: true
          content:
            application/json:
              schema:
                $ref: '#/components/schemas/DeregistrationData'
        responses:
          '204':
            description: Successful Notification response
          '400':
            $ref: 'TS29571_CommonData.yaml#/components/responses/400'
          '404':
            $ref: 'TS29571_CommonData.yaml#/components/responses/404'
          '500':
            $ref: 'TS29571_CommonData.yaml#/components/responses/500'
          '503':
            $ref: 'TS29571_CommonData.yaml#/components/responses/503'
          default:
            description: Unexpected error
  pcsfRestorationNotification:
    '{request.body#/pcscfRestorationCallbackUri}':
      post:
        requestBody:
          required: true

```

```

    content:
      application/json:
        schema:
          $ref: '#/components/schemas/PcscfRestorationNotification'
  responses:
    '204':
      description: Successful Notification response
    '400':
      $ref: 'TS29571_CommonData.yaml#/components/responses/400'
    '404':
      $ref: 'TS29571_CommonData.yaml#/components/responses/404'
    '500':
      $ref: 'TS29571_CommonData.yaml#/components/responses/500'
    '503':
      $ref: 'TS29571_CommonData.yaml#/components/responses/503'
  default:
    description: Unexpected error

patch:
  summary: Update a parameter in the AMF registration for 3GPP access
  operationId: Update
  tags:
    - Parameter update in the AMF registration for 3GPP access
  parameters:
    - name: ueId
      in: path
      description: Identifier of the UE
      required: true
      schema:
        $ref: 'TS29571_CommonData.yaml#/components/schemas/Supi'
  requestBody:
    content:
      application/merge-patch+json:
        schema:
          $ref: '#/components/schemas/Amf3GppAccessRegistrationModification'
        required: true
  responses:
    '204':
      description: Expected response to a valid request
    '400':
      $ref: 'TS29571_CommonData.yaml#/components/responses/400'
    '403':
      $ref: 'TS29571_CommonData.yaml#/components/responses/403'
    '404':
      $ref: 'TS29571_CommonData.yaml#/components/responses/404'
    '422':
      description: Unprocessable Request
      content:
        application/problem+json:
          schema:
            $ref: 'TS29571_CommonData.yaml#/components/schemas/ProblemDetails'
    '500':
      $ref: 'TS29571_CommonData.yaml#/components/responses/500'
    '503':
      $ref: 'TS29571_CommonData.yaml#/components/responses/503'
  default:
    description: Unexpected error

get:
  summary: retrieve the AMF registration for 3GPP access information
  operationId: Get
  tags:
    - AMF 3Gpp-access Registration Info Retrieval
  parameters:
    - name: ueId
      in: path
      description: Identifier of the UE
      required: true
      schema:
        $ref: 'TS29571_CommonData.yaml#/components/schemas/Gpsi'
    - name: supported-features
      in: query
      schema:
        $ref: 'TS29571_CommonData.yaml#/components/schemas/SupportedFeatures'
  responses:
    '200':
      description: Expected response to a valid request
      content:
        application/json:

```

```

    schema:
      $ref: '#/components/schemas/Amf3GppAccessRegistration'
'400':
  $ref: 'TS29571_CommonData.yaml#/components/responses/400'
'403':
  $ref: 'TS29571_CommonData.yaml#/components/responses/403'
'404':
  $ref: 'TS29571_CommonData.yaml#/components/responses/404'
'500':
  $ref: 'TS29571_CommonData.yaml#/components/responses/500'
'503':
  $ref: 'TS29571_CommonData.yaml#/components/responses/503'
default:
  description: Unexpected error

/{ueId}/registrations/amf-non-3gpp-access:
  put:
    summary: register as AMF for non-3GPP access
    operationId: Register
    tags:
      - AMF registration for non-3GPP access
    parameters:
      - name: ueId
        in: path
        description: Identifier of the UE
        required: true
        schema:
          $ref: 'TS29571_CommonData.yaml#/components/schemas/Supi'
    requestBody:
      content:
        application/json:
          schema:
            $ref: '#/components/schemas/AmfNon3GppAccessRegistration'
      required: true
    responses:
      '201':
        description: Created
        content:
          application/json:
            schema:
              $ref: '#/components/schemas/AmfNon3GppAccessRegistration'
        headers:
          Location:
            description: 'Contains the URI of the newly created resource, according to the
structure: {apiRoot}/nudm-uecm/v1/{ueId}/registrations/amf-non-3gpp-access'
            required: true
            schema:
              type: string
      '200':
        description: OK
        content:
          application/json:
            schema:
              $ref: '#/components/schemas/AmfNon3GppAccessRegistration'
      '204':
        description: No Content
      '400':
        $ref: 'TS29571_CommonData.yaml#/components/responses/400'
      '403':
        $ref: 'TS29571_CommonData.yaml#/components/responses/403'
      '404':
        $ref: 'TS29571_CommonData.yaml#/components/responses/404'
      '500':
        $ref: 'TS29571_CommonData.yaml#/components/responses/500'
      '503':
        $ref: 'TS29571_CommonData.yaml#/components/responses/503'
    default:
      description: Unexpected error
    callbacks:
      deregistrationNotification:
        '{request.body#/deregCallbackUri}':
          post:
            requestBody:
              required: true
              content:
                application/json:
                  schema:
                    $ref: '#/components/schemas/DeregistrationData'

```

```

    responses:
      '204':
        description: Successful Notification response
      '400':
        $ref: 'TS29571_CommonData.yaml#/components/responses/400'
      '404':
        $ref: 'TS29571_CommonData.yaml#/components/responses/404'
      '500':
        $ref: 'TS29571_CommonData.yaml#/components/responses/500'
      '503':
        $ref: 'TS29571_CommonData.yaml#/components/responses/503'
      default:
        description: Unexpected error
  pcscfRestorationNotification:
    '{request.body#/pcscfRestorationCallbackUri}':
      post:
        requestBody:
          required: true
          content:
            application/json:
              schema:
                $ref: '#/components/schemas/PcscfRestorationNotification'
        responses:
          '204':
            description: Successful Notification response
          '400':
            $ref: 'TS29571_CommonData.yaml#/components/responses/400'
          '404':
            $ref: 'TS29571_CommonData.yaml#/components/responses/404'
          '500':
            $ref: 'TS29571_CommonData.yaml#/components/responses/500'
          '503':
            $ref: 'TS29571_CommonData.yaml#/components/responses/503'
          default:
            description: Unexpected error
  patch:
    summary: update a parameter in the AMF registration for non-3GPP access
    operationId: Update
    tags:
      - Parameter update in the AMF registration for non-3GPP access
    parameters:
      - name: ueId
        in: path
        description: Identifier of the UE
        required: true
        schema:
          $ref: 'TS29571_CommonData.yaml#/components/schemas/Supi'
    requestBody:
      content:
        application/merge-patch+json:
          schema:
            $ref: '#/components/schemas/AmfNon3GppAccessRegistrationModification'
      required: true
    responses:
      '204':
        description: Expected response to a valid request
      '400':
        $ref: 'TS29571_CommonData.yaml#/components/responses/400'
      '404':
        $ref: 'TS29571_CommonData.yaml#/components/responses/404'
      '422':
        description: Unprocessable Request
        content:
          application/problem+json:
            schema:
              $ref: 'TS29571_CommonData.yaml#/components/schemas/ProblemDetails'
      '500':
        $ref: 'TS29571_CommonData.yaml#/components/responses/500'
      '503':
        $ref: 'TS29571_CommonData.yaml#/components/responses/503'
      default:
        description: Unexpected error
  get:
    summary: retrieve the AMF registration for non-3GPP access information
    operationId: Get
    tags:
      - AMF non-3GPP-access Registration Info Retrieval
    parameters:

```



```

- name: ueId
  in: path
  description: Identifier of the UE
  required: true
  schema:
    $ref: 'TS29571_CommonData.yaml#/components/schemas/Gpsi'
- name: supported-features
  in: query
  schema:
    $ref: 'TS29571_CommonData.yaml#/components/schemas/SupportedFeatures'
responses:
  '200':
    description: Expected response to a valid request
    content:
      application/json:
        schema:
          $ref: '#/components/schemas/AmfNon3GppAccessRegistration'
  '400':
    $ref: 'TS29571_CommonData.yaml#/components/responses/400'
  '403':
    $ref: 'TS29571_CommonData.yaml#/components/responses/403'
  '404':
    $ref: 'TS29571_CommonData.yaml#/components/responses/404'
  '500':
    $ref: 'TS29571_CommonData.yaml#/components/responses/500'
  '503':
    $ref: 'TS29571_CommonData.yaml#/components/responses/503'
default:
  description: Unexpected error

/{ueId}/registrations/smf-registrations/{pduSessionId}:
  put:
    summary: register as SMF
    operationId: Registration
    tags:
      - SMF Registration
    parameters:
      - name: ueId
        in: path
        description: Identifier of the UE
        required: true
        schema:
          $ref: 'TS29571_CommonData.yaml#/components/schemas/Supi'
      - name: pduSessionId
        in: path
        description: Identifier of the PDU session
        required: true
        schema:
          $ref: 'TS29571_CommonData.yaml#/components/schemas/PduSessionId'
    requestBody:
      content:
        application/json:
          schema:
            $ref: '#/components/schemas/SmfRegistration'
      required: true
    responses:
      '201':
        description: Created
        content:
          application/json:
            schema:
              $ref: '#/components/schemas/SmfRegistration'
        headers:
          Location:
            description: 'Contains the URI of the newly created resource, according to the
structure: {apiRoot}/nudm-uecm/v1/{ueId}/registrations/smf-registrations/{pduSessionId}'
            required: true
            schema:
              type: string
      '200':
        description: Expected response to a valid request
        content:
          application/json:
            schema:
              $ref: '#/components/schemas/SmfRegistration'
      '204':
        description: No content
      '400':

```

```

    $ref: 'TS29571_CommonData.yaml#/components/responses/400'
  '403':
    $ref: 'TS29571_CommonData.yaml#/components/responses/403'
  '404':
    $ref: 'TS29571_CommonData.yaml#/components/responses/404'
  '500':
    $ref: 'TS29571_CommonData.yaml#/components/responses/500'
  '503':
    $ref: 'TS29571_CommonData.yaml#/components/responses/503'
  default:
    description: Unexpected error
  callbacks:
    pcscfRestorationNotification:
      '{request.body#/pcscfRestorationCallbackUri}':
        post:
          requestBody:
            required: true
            content:
              application/json:
                schema:
                  $ref: '#/components/schemas/PcscfRestorationNotification'
    responses:
      '204':
        description: Successful Notification response
      '400':
        $ref: 'TS29571_CommonData.yaml#/components/responses/400'
      '404':
        $ref: 'TS29571_CommonData.yaml#/components/responses/404'
      '500':
        $ref: 'TS29571_CommonData.yaml#/components/responses/500'
      '503':
        $ref: 'TS29571_CommonData.yaml#/components/responses/503'
      default:
        description: Unexpected error
  delete:
    summary: delete an SMF registration
    operationId: Deregistration
    tags:
      - SMF Deregistration
    parameters:
      - name: ueId
        in: path
        description: Identifier of the UE
        required: true
        schema:
          $ref: 'TS29571_CommonData.yaml#/components/schemas/Supi'
      - name: pduSessionId
        in: path
        description: Identifier of the PDU session
        required: true
        schema:
          $ref: 'TS29571_CommonData.yaml#/components/schemas/PduSessionId'
    responses:
      '204':
        description: Expected response to a valid request
      '400':
        $ref: 'TS29571_CommonData.yaml#/components/responses/400'
      '404':
        $ref: 'TS29571_CommonData.yaml#/components/responses/404'
      '422':
        description: Unprocessable Request
        content:
          application/problem+json:
            schema:
              $ref: 'TS29571_CommonData.yaml#/components/schemas/ProblemDetails'
      '500':
        $ref: 'TS29571_CommonData.yaml#/components/responses/500'
      '503':
        $ref: 'TS29571_CommonData.yaml#/components/responses/503'
      default:
        description: Unexpected error
  /{ueId}/registrations/smsf-3gpp-access:
    put:
      summary: register as SMSF for 3GPP access
      operationId: Update SMSF Reg 3GPP
      tags:
        - SMSF registration for 3GPP access

```

```

parameters:
  - name: ueId
    in: path
    description: Identifier of the UE
    required: true
    schema:
      $ref: 'TS29571_CommonData.yaml#/components/schemas/Supi'
requestBody:
  content:
    application/json:
      schema:
        $ref: '#/components/schemas/SmsfRegistration'
    required: true
responses:
  '201':
    description: Created
    content:
      application/json:
        schema:
          $ref: '#/components/schemas/SmsfRegistration'
    headers:
      Location:
        description: 'Contains the URI of the newly created resource, according to the
structure: {apiRoot}/nudm-uecm/v1/{ueId}/registrations/smsf-3gpp-access'
        required: true
        schema:
          type: string
  '200':
    description: Expected response to a valid request
    content:
      application/json:
        schema:
          $ref: '#/components/schemas/SmsfRegistration'
  '204':
    description: No content
  '400':
    $ref: 'TS29571_CommonData.yaml#/components/responses/400'
  '403':
    $ref: 'TS29571_CommonData.yaml#/components/responses/403'
  '404':
    $ref: 'TS29571_CommonData.yaml#/components/responses/404'
  '500':
    $ref: 'TS29571_CommonData.yaml#/components/responses/500'
  '503':
    $ref: 'TS29571_CommonData.yaml#/components/responses/503'
  default:
    description: Unexpected error
delete:
  summary: delete the SMSF registration for 3GPP access
  operationId: Deregistration
  tags:
    - SMSF Deregistration for 3GPP Access
  parameters:
    - name: ueId
      in: path
      description: Identifier of the UE
      required: true
      schema:
        $ref: 'TS29571_CommonData.yaml#/components/schemas/Supi'
  responses:
    '204':
      description: Expected response to a valid request
    '400':
      $ref: 'TS29571_CommonData.yaml#/components/responses/400'
    '404':
      $ref: 'TS29571_CommonData.yaml#/components/responses/404'
    '422':
      description: Unprocessable Request
      content:
        application/problem+json:
          schema:
            $ref: 'TS29571_CommonData.yaml#/components/schemas/ProblemDetails'
    '500':
      $ref: 'TS29571_CommonData.yaml#/components/responses/500'
    '503':
      $ref: 'TS29571_CommonData.yaml#/components/responses/503'
  default:
    description: Unexpected error

```

```

get:
  summary: retrieve the SMSF registration for 3GPP access information
  operationId: Get
  tags:
    - SMSF 3GPP access Registration Info Retrieval
  parameters:
    - name: ueId
      in: path
      description: Identifier of the UE
      required: true
      schema:
        $ref: 'TS29571_CommonData.yaml#/components/schemas/Gpsi'
    - name: supported-features
      in: query
      schema:
        $ref: 'TS29571_CommonData.yaml#/components/schemas/SupportedFeatures'
  responses:
    '200':
      description: Expected response to a valid request
      content:
        application/json:
          schema:
            $ref: '#/components/schemas/SmsfRegistration'
    '400':
      $ref: 'TS29571_CommonData.yaml#/components/responses/400'
    '403':
      $ref: 'TS29571_CommonData.yaml#/components/responses/403'
    '404':
      $ref: 'TS29571_CommonData.yaml#/components/responses/404'
    '500':
      $ref: 'TS29571_CommonData.yaml#/components/responses/500'
    '503':
      $ref: 'TS29571_CommonData.yaml#/components/responses/503'
  default:
    description: Unexpected error

/{ueId}/registrations/smsf-non-3gpp-access:
  put:
    summary: register as SMSF for non-3GPP access
    operationId: Registration
    tags:
      - SMSF registration for non-3GPP access
    parameters:
      - name: ueId
        in: path
        description: Identifier of the UE
        required: true
        schema:
          $ref: 'TS29571_CommonData.yaml#/components/schemas/Supi'
    requestBody:
      content:
        application/json:
          schema:
            $ref: '#/components/schemas/SmsfRegistration'
      required: true
    responses:
      '201':
        description: Created
        content:
          application/json:
            schema:
              $ref: '#/components/schemas/SmsfRegistration'
        headers:
          Location:
            description: 'Contains the URI of the newly created resource, according to the
structure: {apiRoot}/nudm-uecm/v1/{ueId}/registrations/smsf-non-3gpp-access'
            required: true
            schema:
              type: string
      '200':
        description: Expected response to a valid request
        content:
          application/json:
            schema:
              $ref: '#/components/schemas/SmsfRegistration'
      '204':
        description: No content
      '400':

```

```

    $ref: 'TS29571_CommonData.yaml#/components/responses/400'
  '403':
    $ref: 'TS29571_CommonData.yaml#/components/responses/403'
  '404':
    $ref: 'TS29571_CommonData.yaml#/components/responses/404'
  '500':
    $ref: 'TS29571_CommonData.yaml#/components/responses/500'
  '503':
    $ref: 'TS29571_CommonData.yaml#/components/responses/503'
  default:
    description: Unexpected error
delete:
  summary: delete SMSF registration for non 3GPP access
  operationId: Deregistration
  tags:
    - SMSF Deregistration for non-3GPP access
  parameters:
    - name: ueId
      in: path
      description: Identifier of the UE
      required: true
      schema:
        $ref: 'TS29571_CommonData.yaml#/components/schemas/Supi'
  responses:
    '204':
      description: Expected response to a valid request
    '400':
      $ref: 'TS29571_CommonData.yaml#/components/responses/400'
    '404':
      $ref: 'TS29571_CommonData.yaml#/components/responses/404'
    '422':
      description: Unprocessable Request
      content:
        application/problem+json:
          schema:
            $ref: 'TS29571_CommonData.yaml#/components/schemas/ProblemDetails'
    '500':
      $ref: 'TS29571_CommonData.yaml#/components/responses/500'
    '503':
      $ref: 'TS29571_CommonData.yaml#/components/responses/503'
  default:
    description: Unexpected error
get:
  summary: retrieve the SMSF registration for non-3GPP access information
  operationId: Get
  tags:
    - SMSF non-3GPP access Registration Info Retrieval
  parameters:
    - name: ueId
      in: path
      description: Identifier of the UE
      required: true
      schema:
        $ref: 'TS29571_CommonData.yaml#/components/schemas/Gpsi'
    - name: supported-features
      in: query
      schema:
        $ref: 'TS29571_CommonData.yaml#/components/schemas/SupportedFeatures'
  responses:
    '200':
      description: Expected response to a valid request
      content:
        application/json:
          schema:
            $ref: '#/components/schemas/SmsfRegistration'
    '400':
      $ref: 'TS29571_CommonData.yaml#/components/responses/400'
    '403':
      $ref: 'TS29571_CommonData.yaml#/components/responses/403'
    '404':
      $ref: 'TS29571_CommonData.yaml#/components/responses/404'
    '500':
      $ref: 'TS29571_CommonData.yaml#/components/responses/500'
    '503':
      $ref: 'TS29571_CommonData.yaml#/components/responses/503'
  default:
    description: Unexpected error

```

```

components:
  securitySchemes:
    oAuth2ClientCredentials:
      type: oauth2
      flows:
        clientCredentials:
          tokenUrl: '{nrfApiRoot}/oauth2/token'
          scopes:
            nudm-uecm: Access to the nudm-uecm API

  schemas:

# COMPLEX TYPES:

Amf3GppAccessRegistration:
  type: object
  required:
    - amfInstanceId
    - deregCallbackUri
    - guami
    - ratType
  properties:
    amfInstanceId:
      $ref: 'TS29571_CommonData.yaml#/components/schemas/NfInstanceId'
    supportedFeatures:
      $ref: 'TS29571_CommonData.yaml#/components/schemas/SupportedFeatures'
    purgeFlag:
      $ref: '#/components/schemas/PurgeFlag'
    pei:
      $ref: 'TS29571_CommonData.yaml#/components/schemas/Pei'
    imsVoPs:
      $ref: '#/components/schemas/ImsVoPs'
    deregCallbackUri:
      $ref: 'TS29571_CommonData.yaml#/components/schemas/Uri'
    amfServiceNameDereg:
      $ref: 'TS29510_Nnrf_NFManagement.yaml#/components/schemas/ServiceName'
    pcsfRestorationCallbackUri:
      $ref: 'TS29571_CommonData.yaml#/components/schemas/Uri'
    amfServiceNamePcsfRest:
      $ref: 'TS29510_Nnrf_NFManagement.yaml#/components/schemas/ServiceName'
    initialRegistrationInd:
      type: boolean
    guami:
      $ref: 'TS29571_CommonData.yaml#/components/schemas/Guami'
    backupAmfInfo:
      type: array
      items:
        $ref: 'TS29571_CommonData.yaml#/components/schemas/BackupAmfInfo'
      minItems: 1
    drFlag:
      $ref: '#/components/schemas/DualRegistrationFlag'
    ratType:
      $ref: 'TS29571_CommonData.yaml#/components/schemas/RatType'

Amf3GppAccessRegistrationModification:
  type: object
  required:
    - guami
  properties:
    guami:
      $ref: 'TS29571_CommonData.yaml#/components/schemas/Guami'
    purgeFlag:
      $ref: '#/components/schemas/PurgeFlag'
    pei:
      $ref: 'TS29571_CommonData.yaml#/components/schemas/Pei'
    imsVoPs:
      $ref: '#/components/schemas/ImsVoPs'
    backupAmfInfo:
      type: array
      items:
        $ref: 'TS29571_CommonData.yaml#/components/schemas/BackupAmfInfo'

AmfNon3GppAccessRegistration:
  type: object
  required:
    - amfInstanceId
    - imsVoPs

```

```

    - deregCallbackUri
    - guami
    - ratType
  properties:
    amfInstanceId:
      $ref: 'TS29571_CommonData.yaml#/components/schemas/NfInstanceId'
    supportedFeatures:
      $ref: 'TS29571_CommonData.yaml#/components/schemas/SupportedFeatures'
    purgeFlag:
      $ref: '#/components/schemas/PurgeFlag'
    pei:
      $ref: 'TS29571_CommonData.yaml#/components/schemas/Pei'
    imsVoPs:
      $ref: '#/components/schemas/ImsVoPs'
    deregCallbackUri:
      $ref: 'TS29571_CommonData.yaml#/components/schemas/Uri'
    amfServiceNameDereg:
      $ref: 'TS29510_Nnrf_NFManagement.yaml#/components/schemas/ServiceName'
    pcsfRestorationCallbackUri:
      $ref: 'TS29571_CommonData.yaml#/components/schemas/Uri'
    amfServiceNamePcsfRest:
      $ref: 'TS29510_Nnrf_NFManagement.yaml#/components/schemas/ServiceName'
    guami:
      $ref: 'TS29571_CommonData.yaml#/components/schemas/Guami'
    backupAmfInfo:
      type: array
      items:
        $ref: 'TS29571_CommonData.yaml#/components/schemas/BackupAmfInfo'
      minItems: 1
    ratType:
      $ref: 'TS29571_CommonData.yaml#/components/schemas/RatType'

AmfNon3GppAccessRegistrationModification:
  type: object
  required:
    - guami
  properties:
    guami:
      $ref: 'TS29571_CommonData.yaml#/components/schemas/Guami'
    purgeFlag:
      $ref: '#/components/schemas/PurgeFlag'
    pei:
      $ref: 'TS29571_CommonData.yaml#/components/schemas/Pei'
    imsVoPs:
      $ref: '#/components/schemas/ImsVoPs'
    backupAmfInfo:
      type: array
      items:
        $ref: 'TS29571_CommonData.yaml#/components/schemas/BackupAmfInfo'

SmfRegistration:
  type: object
  required:
    - smfInstanceId
    - pduSessionId
    - singleNssai
    - dnn
    - plmnId
  properties:
    smfInstanceId:
      $ref: 'TS29571_CommonData.yaml#/components/schemas/NfInstanceId'
    supportedFeatures:
      $ref: 'TS29571_CommonData.yaml#/components/schemas/SupportedFeatures'
    pduSessionId:
      $ref: 'TS29571_CommonData.yaml#/components/schemas/PduSessionId'
    singleNssai:
      $ref: 'TS29571_CommonData.yaml#/components/schemas/Snssai'
    dnn:
      $ref: 'TS29571_CommonData.yaml#/components/schemas/Dnn'
    pcsfRestorationCallbackUri:
      $ref: 'TS29571_CommonData.yaml#/components/schemas/Uri'
    plmnId:
      $ref: 'TS29571_CommonData.yaml#/components/schemas/PlmnId'
    pgwFqdn:
      type: string

SmsfRegistration:

```

```
type: object
required:
  - smsfInstanceId
  - plmnId
properties:
  smsfInstanceId:
    $ref: 'TS29571_CommonData.yaml#/components/schemas/NfInstanceId'
  supportedFeatures:
    $ref: 'TS29571_CommonData.yaml#/components/schemas/SupportedFeatures'
  plmnId:
    $ref: 'TS29571_CommonData.yaml#/components/schemas/PlmnId'
  smsfMAPAddress:
    $ref: '#/components/schemas/E164Number'
  smsfDiameterAddress:
    $ref: '#/components/schemas/NetworkNodeDiameterAddress'

DeregistrationData:
type: object
required:
  - deregReason
  - accessType
properties:
  deregReason:
    $ref: '#/components/schemas/DeregistrationReason'
  accessType:
    $ref: 'TS29571_CommonData.yaml#/components/schemas/AccessType'

PcscfRestorationNotification:
type: object
required:
  - supi
properties:
  supi:
    $ref: 'TS29571_CommonData.yaml#/components/schemas/Supi'

NetworkNodeDiameterAddress:
type: object
required:
  - name
  - realm
properties:
  name:
    $ref: 'TS29571_CommonData.yaml#/components/schemas/DiameterIdentity'
  realm:
    $ref: 'TS29571_CommonData.yaml#/components/schemas/DiameterIdentity'

# SIMPLE TYPES:

PurgeFlag:
  type: boolean

E164Number:
  type: string
  pattern: '^[0-9]{1,15}$'

DualRegistrationFlag:
  type: boolean

# ENUMS:

ImsVoPs:
  anyOf:
    - type: string
      enum:
        - HOMOGENEOUS_SUPPORT
        - HOMOGENEOUS_NON_SUPPORT
        - NON_HOMOGENEOUS_OR_UNKNOWN
    - type: string

DeregistrationReason:
  anyOf:
    - type: string
      enum:
        - UE_INITIAL_REGISTRATION
        - UE_REGISTRATION_AREA_CHANGE
        - SUBSCRIPTION_WITHDRAWN
        - 5GS_TO_EPS_MOBILITY
        - 5GS_TO_EPS_MOBILITY_UE_INITIAL_REGISTRATION
```

- REREGISTRATION_REQUIRED
- type: string

A.4 Nudm_UEAU API

```

openapi: 3.0.0
info:
  version: '1.0.0'
  title: 'NudmUEAU'
  description: 'UDM UE Authentication Service'

externalDocs:
  description: 3GPP TS 29.503 Unified Data Management Services, version 15.2.1
  url: 'http://www.3gpp.org/ftp/Specs/archive/29_series/29.503/'

servers:
  - url: '{apiRoot}/nudm-ueau/v1'
    variables:
      apiRoot:
        default: https://example.com
        description: apiRoot as defined in subclause subclause 4.4 of 3GPP TS 29.501.

security:
  - oAuth2ClientCredentials:
    - nudm-ueau
  - {}

paths:
  /{supiOrSuci}/security-information/generate-auth-data:
    post:
      summary: Generate authentication data for the UE
      operationId: GenerateAuthData
      tags:
        - Generate Auth Data
      parameters:
        - name: supiOrSuci
          in: path
          description: SUPI or SUCI of the user
          required: true
          schema:
            $ref: '#/components/schemas/SupiOrSuci'
      requestBody:
        content:
          application/json:
            schema:
              $ref: '#/components/schemas/AuthenticationInfoRequest'
        required: true
      responses:
        '200':
          description: Expected response to a valid request
          content:
            application/json:
              schema:
                $ref: '#/components/schemas/AuthenticationInfoResult'
        '400':
          $ref: 'TS29571_CommonData.yaml#/components/responses/400'
        '403':
          $ref: 'TS29571_CommonData.yaml#/components/responses/403'
        '404':
          $ref: 'TS29571_CommonData.yaml#/components/responses/404'
        '500':
          $ref: 'TS29571_CommonData.yaml#/components/responses/500'
        '501':
          $ref: 'TS29571_CommonData.yaml#/components/responses/501'
        '503':
          $ref: 'TS29571_CommonData.yaml#/components/responses/503'
      default:
        description: Unexpected error

  /{supi}/auth-events:
    post:
      summary: Create a new confirmation event
      operationId: ConfirmAuth
      tags:
        - Confirm Auth
      parameters:

```

```

    - name: supi
      in: path
      description: SUPI of the user
      required: true
      schema:
        $ref: 'TS29571_CommonData.yaml#/components/schemas/Supi'
  requestBody:
    content:
      application/json:
        schema:
          $ref: '#/components/schemas/AuthEvent'
        required: true
  responses:
    '201':
      description: Expected response to a valid request
      content:
        application/json:
          schema:
            $ref: '#/components/schemas/AuthEvent'
      headers:
        Location:
          description: 'Contains the URI of the newly created resource, according to the
structure: {apiRoot}/nudm-ueau/v1/{supi}/auth-events/{authEventId}'
          required: true
          schema:
            type: string
    '400':
      $ref: 'TS29571_CommonData.yaml#/components/responses/400'
    '404':
      $ref: 'TS29571_CommonData.yaml#/components/responses/404'
    '500':
      $ref: 'TS29571_CommonData.yaml#/components/responses/500'
    '503':
      $ref: 'TS29571_CommonData.yaml#/components/responses/503'
  default:
    description: Unexpected error

components:
  securitySchemes:
    oAuth2ClientCredentials:
      type: oauth2
      flows:
        clientCredentials:
          tokenUrl: '{nrfApiRoot}/oauth2/token'
          scopes:
            nudm-ueau: Access to the nudm-ueau API

  schemas:

# COMPLEX TYPES:

AuthenticationInfoRequest:
  type: object
  required:
    - servingNetworkName
    - ausfInstanceId
  properties:
    supportedFeatures:
      $ref: 'TS29571_CommonData.yaml#/components/schemas/SupportedFeatures'
    servingNetworkName:
      $ref: '#/components/schemas/ServingNetworkName'
    resynchronizationInfo:
      $ref: '#/components/schemas/ResynchronizationInfo'
    ausfInstanceId:
      $ref: 'TS29571_CommonData.yaml#/components/schemas/NfInstanceId'

AuthenticationInfoResult:
  type: object
  required:
    - authType
  properties:
    authType:
      $ref: '#/components/schemas/AuthType'
    supportedFeatures:
      $ref: 'TS29571_CommonData.yaml#/components/schemas/SupportedFeatures'
    authenticationVector:
      $ref: '#/components/schemas/AuthenticationVector'

```

```
supi:
  $ref: 'TS29571_CommonData.yaml#/components/schemas/Supi'

AuthenticationVector:
  oneOf:
    - $ref: '#/components/schemas/AvEapAkaPrime'
    - $ref: '#/components/schemas/Av5GHeAka'
  discriminator:
    propertyName: avType
    mapping:
      5G_HE_AKA: '#/components/schemas/Av5GHeAka'
      EAP_AKA_PRIME: '#/components/schemas/AvEapAkaPrime'

AvEapAkaPrime:
  type: object
  required:
    - avType
    - rand
    - xres
    - autn
    - ckPrime
    - ikPrime
  properties:
    avType:
      $ref: '#/components/schemas/AvType'
    rand:
      $ref: '#/components/schemas/Rand'
    xres:
      $ref: '#/components/schemas/Xres'
    autn:
      $ref: '#/components/schemas/Autn'
    ckPrime:
      $ref: '#/components/schemas/CkPrime'
    ikPrime:
      $ref: '#/components/schemas/IkPrime'

Av5GHeAka:
  type: object
  required:
    - avType
    - rand
    - xresStar
    - autn
    - kausf
  properties:
    avType:
      $ref: '#/components/schemas/AvType'
    rand:
      $ref: '#/components/schemas/Rand'
    xresStar:
      $ref: '#/components/schemas/XresStar'
    autn:
      $ref: '#/components/schemas/Autn'
    kausf:
      $ref: '#/components/schemas/Kausf'

ResynchronizationInfo:
  type: object
  required:
    - rand
    - auts
  properties:
    rand:
      $ref: '#/components/schemas/Rand'
    auts:
      $ref: '#/components/schemas/Auts'

AuthEvent:
  type: object
  required:
    - nfInstanceId
    - success
    - timeStamp
    - authType
    - servingNetworkName
  properties:
    nfInstanceId:
      $ref: 'TS29571_CommonData.yaml#/components/schemas/NfInstanceId'
```

```

    success:
      $ref: '#/components/schemas/Success'
    timeStamp:
      $ref: 'TS29571_CommonData.yaml#/components/schemas/DateTime'
    authType:
      $ref: '#/components/schemas/AuthType'
    servingNetworkName:
      $ref: '#/components/schemas/ServingNetworkName'

# SIMPLE TYPES:

Autn:
  type: string
  pattern: '^[A-Fa-f0-9]{32}$'

Auts:
  type: string
  pattern: '^[A-Fa-f0-9]{28}$'

CkPrime:
  type: string
  pattern: '^[A-Fa-f0-9]{32}$'

IkPrime:
  type: string
  pattern: '^[A-Fa-f0-9]{32}$'

Kausf:
  type: string
  pattern: '^[A-Fa-f0-9]{64}$'

Rand:
  type: string
  pattern: '^[A-Fa-f0-9]{32}$'

Xres:
  type: string
  pattern: '^[A-Fa-f0-9]{8,32}$'

XresStar:
  type: string
  pattern: '^[A-Fa-f0-9]{32}$'

SupiOrSuci:
  type: string
  pattern: '^(imsi-[0-9]{5,15}|nai-.+|suci-(0-[0-9]{3}-[0-9]{2,3}|[1-7]-.+)-[0-9]{1,4}-(0-0-
.+|[a-fA-F1-9]-([1-9]|1[0-9]|1[0-9]{2}|2[0-4][0-9]|25[0-5]))-[a-fA-F0-9]+)|.+$'

ServingNetworkName:
  type: string
  pattern: '^5G:mnc[0-9]{3}[.]mcc[0-9]{3}[.]3gppnetwork[.]org$'

Success:
  type: boolean

# ENUMS:

AuthType:
  anyOf:
    - type: string
      enum:
        - 5G_AKA
        - EAP_AKA_PRIME
        - EAP_TLS
    - type: string

AvType:
  anyOf:
    - type: string
      enum:
        - 5G_HE_AKA
        - EAP_AKA_PRIME
    - type: string

```

A.5 Nudm_EE API

```

openapi: 3.0.0

info:
  version: '1.0.0'
  title: 'Nudm_EE'
  description: 'Nudm Event Exposure Service'

externalDocs:
  description: 3GPP TS 29.503 Unified Data Management Services, version 15.2.1
  url: 'http://www.3gpp.org/ftp/Specs/archive/29_series/29.503/'

servers:
- url: '{apiRoot}/nudm-ee/v1'
  variables:
    apiRoot:
      default: https://example.com
      description: apiRoot as defined in subclause subclause 4.4 of 3GPP TS 29.501.

security:
- oAuth2ClientCredentials:
  - nudm-ee
- {}

paths:
  /{ueIdentity}/ee-subscriptions:
    post:
      summary: Subscribe
      operationId: CreateEeSubscription
      tags:
        - Create EE Subscription
      parameters:
        - name: ueIdentity
          in: path
          description: Represents the scope of the UE for which the subscription is applied.
          Contains the GPSI of the user or the external group ID or any UE.
          required: true
          schema:
            type: string
            pattern: '^(\msisdn-[0-9]{5,15}|.+|extid-[^@]+@[^@]+|extgroupid-[^@]+@[^@]+|anyUE)$'
      requestBody:
        content:
          application/json:
            schema:
              $ref: '#/components/schemas/EeSubscription'
            required: true
      responses:
        '201':
          description: Expected response to a valid request
          content:
            application/json:
              schema:
                $ref: '#/components/schemas/CreatedEeSubscription'
          headers:
            Location:
              description: 'Contains the URI of the newly created resource, according to the
structure: {apiRoot}/nudm-ee/v1/{ueIdentity}/ee-subscriptions/{subscriptionId}'
              required: true
              schema:
                type: string
        '400':
          $ref: 'TS29571_CommonData.yaml#/components/responses/400'
        '403':
          $ref: 'TS29571_CommonData.yaml#/components/responses/403'
        '404':
          $ref: 'TS29571_CommonData.yaml#/components/responses/404'
        '500':
          $ref: 'TS29571_CommonData.yaml#/components/responses/500'
        '501':
          $ref: 'TS29571_CommonData.yaml#/components/responses/501'
        '503':
          $ref: 'TS29571_CommonData.yaml#/components/responses/503'
      default:
        description: Unexpected error
    callbacks:
      eventOccurrenceNotification:

```

```

    '{request.body#/callbackReference}':
      post:
        requestBody:
          required: true
          content:
            application/json:
              schema:
                type: array
                items:
                  $ref: '#/components/schemas/MonitoringReport'
                minItems: 1
        responses:
          '204':
            description: Successful Notification response
          '400':
            $ref: 'TS29571_CommonData.yaml#/components/responses/400'
          '404':
            $ref: 'TS29571_CommonData.yaml#/components/responses/404'
          '500':
            $ref: 'TS29571_CommonData.yaml#/components/responses/500'
          '503':
            $ref: 'TS29571_CommonData.yaml#/components/responses/503'
          default:
            description: Unexpected error

/{ueIdentity}/ee-subscriptions/{subscriptionId}:
  delete:
    summary: Unsubscribe
    operationId: DeleteEeSubscription
    tags:
      - Delete EE Subscription
    parameters:
      - name: ueIdentity
        in: path
        description: Represents the scope of the UE for which the subscription is applied.
        Contains the GPSI of the user or the external group ID or any UE.
        required: true
        schema:
          type: string
          pattern: '^(msisdn-[0-9]{5,15}|.+|extid-[^@]+@[^@]+|extgroupid-[^@]+@[^@]+|anyUE)$'
      - name: subscriptionId
        in: path
        description: Id of the EE Subscription
        required: true
        schema:
          type: string
    responses:
      '204':
        description: Successful response
      '400':
        $ref: 'TS29571_CommonData.yaml#/components/responses/400'
      '404':
        $ref: 'TS29571_CommonData.yaml#/components/responses/404'
      '500':
        $ref: 'TS29571_CommonData.yaml#/components/responses/500'
      '503':
        $ref: 'TS29571_CommonData.yaml#/components/responses/503'
      default:
        description: Unexpected error

components:
  securitySchemes:
    oAuth2ClientCredentials:
      type: oauth2
      flows:
        clientCredentials:
          tokenUrl: '{nrfApiRoot}/oauth2/token'
          scopes:
            nudm-ee: Access to the nudm-ee API

schemas:

# COMPLEX TYPES:

CreatedEeSubscription:
  type: object
  required:

```

```

- eeSubscription
properties:
  eeSubscription:
    $ref: '#/components/schemas/EeSubscription'
  numberOfUses:
    $ref: 'TS29571_CommonData.yaml#/components/schemas/UInteger'
  eventReports:
    type: array
    items:
      $ref: '#/components/schemas/MonitoringReport'
    minItems: 1

EeSubscription:
  type: object
  required:
    - callbackReference
    - monitoringConfigurations
  properties:
    callbackReference:
      $ref: 'TS29571_CommonData.yaml#/components/schemas/Uri'
    monitoringConfigurations:
      description: A map (list of key-value pairs where ReferenceId serves as key) of
MonitoringConfigurations
      type: object
      additionalProperties:
        $ref: '#/components/schemas/MonitoringConfiguration'
      minProperties: 1
    reportingOptions:
      $ref: '#/components/schemas/ReportingOptions'
    supportedFeatures:
      $ref: 'TS29571_CommonData.yaml#/components/schemas/SupportedFeatures'

MonitoringConfiguration:
  type: object
  required:
    - eventType
  properties:
    eventType:
      $ref: '#/components/schemas/EventType'
    immediateFlag:
      type: boolean
    locationReportingConfiguration:
      $ref: '#/components/schemas/LocationReportingConfiguration'

LocationReportingConfiguration:
  type: object
  required:
    - currentLocation
  properties:
    currentLocation:
      type: boolean
    oneTime:
      type: boolean
    accuracy:
      $ref: '#/components/schemas/LocationAccuracy'

ReportingOptions:
  type: object
  properties:
    maxNumOfReports:
      $ref: '#/components/schemas/MaxNumOfReports'
    expiry:
      $ref: 'TS29571_CommonData.yaml#/components/schemas/DateTime'

MonitoringReport:
  type: object
  required:
    - referencId
    - eventType
    - timeStamp
  properties:
    referencId:
      $ref: '#/components/schemas/ReferenceId'
    eventType:
      $ref: '#/components/schemas/EventType'
    report:
      $ref: '#/components/schemas/Report'
    gpsi:

```

```
$ref: 'TS29571_CommonData.yaml#/components/schemas/Gpsi'  
timeStamp:  
  $ref: 'TS29571_CommonData.yaml#/components/schemas/DateTime'
```

```
Report:  
  oneOf:  
    - $ref: '#/components/schemas/ChangeOfSupiPeiAssociationReport'  
    - $ref: '#/components/schemas/RoamingStatusReport'
```

```
ChangeOfSupiPeiAssociationReport:  
  type: object  
  required:  
    - newPei  
  properties:  
    newPei:  
      $ref: 'TS29571_CommonData.yaml#/components/schemas/Pei'
```

```
RoamingStatusReport:  
  type: object  
  required:  
    - roaming  
    - newServingPlmn  
  properties:  
    roaming:  
      type:  
        boolean  
    newServingPlmn:  
      $ref: 'TS29571_CommonData.yaml#/components/schemas/PlmnId'
```

SIMPLE TYPES:

```
ReferenceId:  
  type: integer
```

```
MaxNumOfReports:  
  type: integer
```

ENUMS:

```
EventType:  
  anyOf:  
    - type: string  
      enum:  
        - LOSS_OF_CONNECTIVITY  
        - UE_REACHABILITY_FOR_DATA  
        - UE_REACHABILITY_FOR_SMS  
        - LOCATION_REPORTING  
        - CHANGE_OF_SUPI_PEI_ASSOCIATION  
        - ROAMING_STATUS  
        - COMMUNICATION_FAILURE  
        - AVAILABILITY_AFTER_DNN_FAILURE  
    - type: string
```

```
LocationAccuracy:  
  anyOf:  
    - type: string  
      enum:  
        - CELL_LEVEL  
        - TA_LEVEL  
    - type: string
```

A.6 Nudm_PP API

```
openapi: 3.0.0

info:
  version: '1.0.0'
  title: 'Nudm_PP'
  description: 'Nudm Parameter Provision Service'

externalDocs:
  description: 3GPP TS 29.503 Unified Data Management Services, version 15.2.1
  url: 'http://www.3gpp.org/ftp/Specs/archive/29_series/29.503/'

servers:
- url: '{apiRoot}/nudm-pp/v1'
  variables:
    apiRoot:
      default: https://example.com
      description: apiRoot as defined in subclause subclause 4.4 of 3GPP TS 29.501.

security:
- oAuth2ClientCredentials:
  - nudm-pp
- {}

paths:
  /{gpsi}/pp-data:
    patch:
      summary: provision parameters
      operationId: Update
      tags:
        - Subscription Data Update
      parameters:
        - name: gpsi
          in: path
          description: Identifier of the UE
          required: true
          schema:
            $ref: 'TS29571_CommonData.yaml#/components/schemas/Gpsi'
      requestBody:
        content:
          application/merge-patch+json:
            schema:
              $ref: '#/components/schemas/PpData'
            required: true
      responses:
        '204':
          description: Expected response to a valid request
        '400':
          $ref: 'TS29571_CommonData.yaml#/components/responses/400'
        '403':
          $ref: 'TS29571_CommonData.yaml#/components/responses/403'
        '404':
          $ref: 'TS29571_CommonData.yaml#/components/responses/404'
        '500':
          $ref: 'TS29571_CommonData.yaml#/components/responses/500'
        '503':
          $ref: 'TS29571_CommonData.yaml#/components/responses/503'
      default:
        description: Unexpected error

components:
  securitySchemes:
    oAuth2ClientCredentials:
      type: oauth2
      flows:
        clientCredentials:
          tokenUrl: '{nrfApiRoot}/oauth2/token'
          scopes:
            nudm-pp: Access to the nudm-pp API

schemas:

# COMPLEX TYPES:
```

```
PpData:
  type: object
  properties:
    communicationCharacteristics:
      $ref: '#/components/schemas/CommunicationCharacteristics'
    supportedFeatures:
      $ref: 'TS29571_CommonData.yaml#/components/schemas/SupportedFeatures'

CommunicationCharacteristics:
  type: object
  properties:
    ppSubsRegTimer:
      $ref: '#/components/schemas/PpSubsRegTimer'
    ppActiveTime:
      $ref: '#/components/schemas/PpActiveTime'
    ppDlPacketCount:
      $ref: '#/components/schemas/PpDlPacketCount'

PpSubsRegTimer:
  type: object
  required:
    - subsRegTimer
    - afInstanceId
    - referenceId
  properties:
    subsRegTimer:
      $ref: 'TS29571_CommonData.yaml#/components/schemas/DurationSec'
    afInstanceId:
      $ref: 'TS29571_CommonData.yaml#/components/schemas/NfInstanceId'
    referenceId:
      $ref: '#/components/schemas/ReferenceId'
  nullable: true

PpActiveTime:
  type: object
  required:
    - activeTime
    - afInstanceId
    - referenceId
  properties:
    activeTime:
      $ref: 'TS29571_CommonData.yaml#/components/schemas/DurationSec'
    afInstanceId:
      $ref: 'TS29571_CommonData.yaml#/components/schemas/NfInstanceId'
    referenceId:
      $ref: '#/components/schemas/ReferenceId'
  nullable: true

# SIMPLE TYPES:

ReferenceId:
  type: integer

PpDlPacketCount:
  type: integer
  nullable: true

# ENUMS:
```

Annex B (informative): Stateless UDMs

Figure B-1 shows a scenario where the stateless UDM receives and processes a request from an NF.

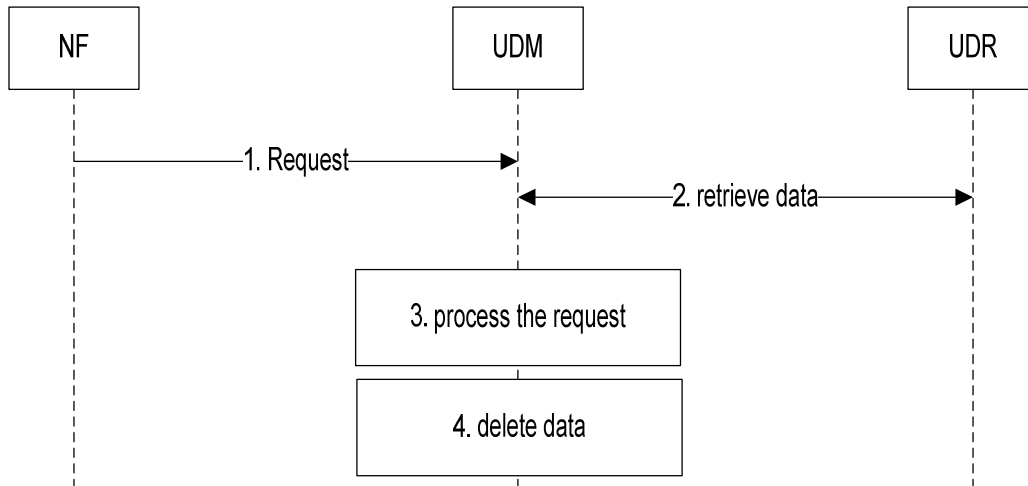

Figure B-1: Stateless UDM

1. The stateless UDM receives a request from an NF. This can be a request to perform an Nudm service, or a Notification that the UDM has previously subscribed to at the NF by means of a service the UDM consumes from the NF. In the later case the NF can be the UDR.
2. The UDM retrieves data from the UDR that are required to process the request. This step can be skipped if the request was a notification from the UDR and contained enough information so that the UDM can process the request.
3. The UDM processes the received request. This can include consuming services from other NFs, consuming services from the UDR (e.g. to update data or subscribe to notifications), and sending notifications to NFs that have subscribed at the UDM to receive notifications, and includes sending the response to the NF (all not shown in the figure).
4. The UDM locally deletes the data retrieved in step 2 and/or received in step 1.

Figure B-2 shows a scenario where an AMF subscribes to notifications of data change (permanent provisioned subscription data) at the stateless UDM. The UDM (UDM 1) stores the subscription to notification in the UE's context data at the UDR.

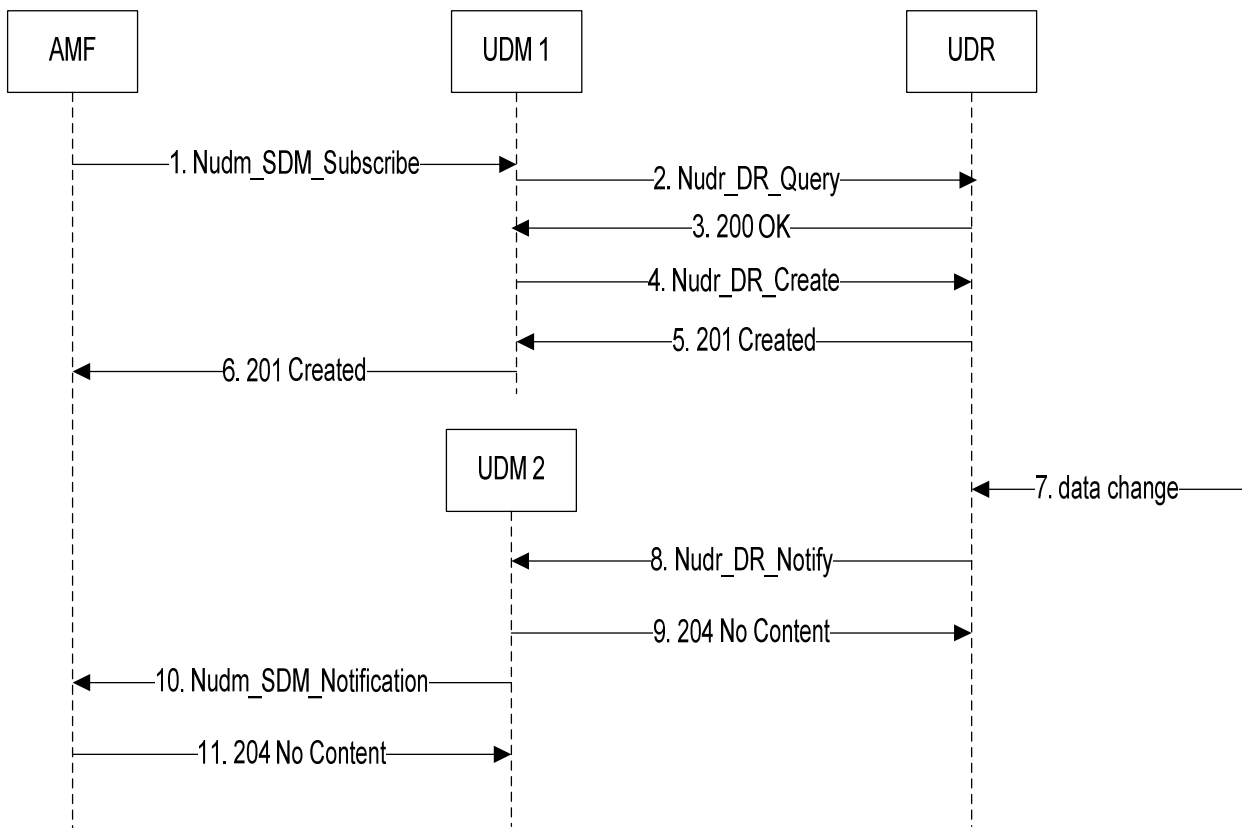

Figure B-2: Subscription to notification

1. The stateless UDM 1 receives a subscribe request from an AMF; see clause 5.2.2.3.2.
- 2.-3 The UDM retrieves UE context data from the UDR to be able to perform required plausibility checks; see 3GPP TS 29.504 [9] clause 5.2.2.2.2.
4. The UDM creates a new sdm subscription at the UDR; see 3GPP TS 29.504 [9] clause 5.2.2.3.3.
5. The UDR sends a 201 Created response containing a subscription ID
6. The UDM send a 201 Created response passing the subscription ID received in step 5 to the AMF.
7. Permanent provisioned Subscription data are modified at the UDR.
8. The UDR selects a suitable UDM and sends a Notification; see 3GPP TS 29.504 [9] clause 5.2.2.8. In addition to the data that have changed, the Notification request message can contain enough (unchanged) information (e.g. the information that has been created in step 4) allowing the UDM to perform step 10 without the need to additionally retrieve information from the UDR.
9. The UDM responds with 204 No Content.
10. The UDM notifies the AMF according to the callback URI of the AMF contained in the Notification received in step 8; see clause 5.2.2.5.2.
11. The AMF responds with 204 No Content.

Figure B-3 shows a scenario where an AMF registers at the stateless UDM. The UDM (UDM 1) stores the registration in the UE's context data at the UDR. The AMF then requests to update the registration e.g. due to change of PEI. This request is sent to UDM2 which belongs to the same UDM group as UDM1.

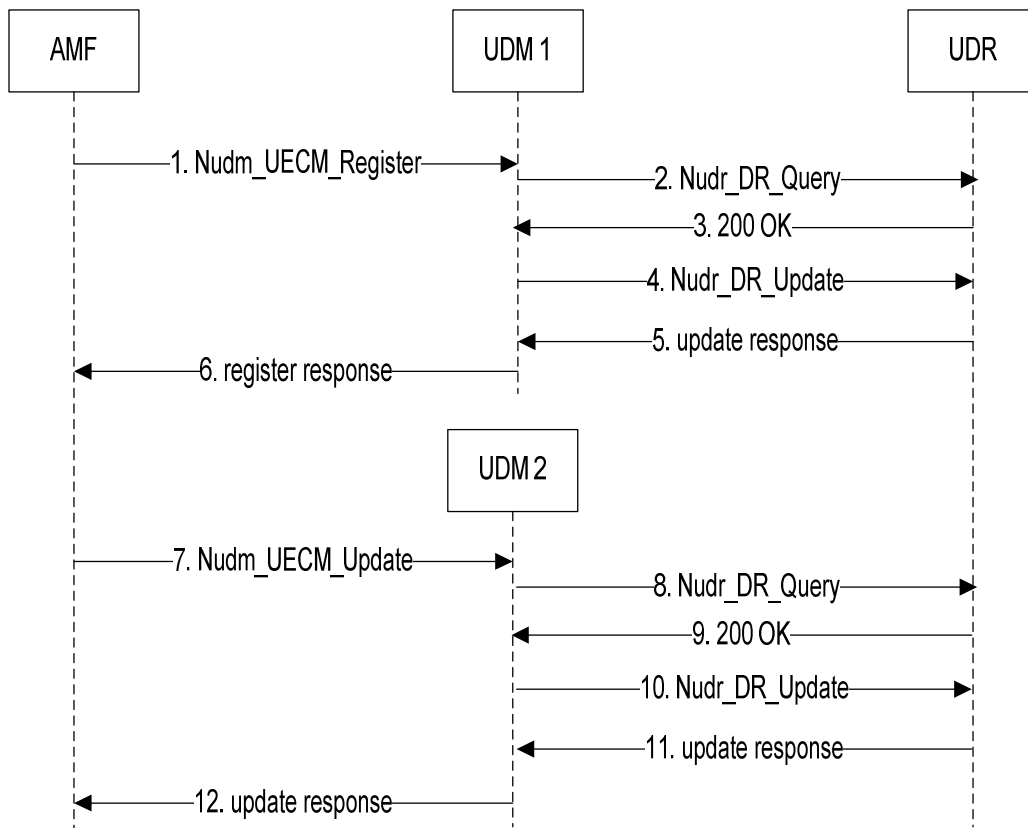

Figure B-3: AMF Registration and Update

1. The AMF discovers (by means of NRF query) and selects an UDM and sends the register request;
- 2.-3 The UDM retrieves UE context data from the UDR e.g. to be able to perform required plausibility checks;
- 4.-5 The UDM updates UE context data in the UDR. The UDM also performs other actions not shown in the figure, e.g deregister an old AMF, notify a subscribed NEF, ...
6. The UDM acknowledges the AMF registration. The AMF stores the UDM group ID as discovered and selected in step 1. The UDM locally deletes the data retrieved in step 3.
7. The AMF sends an update request (e.g. change of PEI) to one of the available UDMs (UDM2) that belongs to the same UDM group as UDM1.
- 8.-9. The UDM retrieves UE context data from the UDR e.g. to be able to perform required plausibility checks;
- 10.-11. The UDM updates UE context data in the UDR. The UDM also performs other actions not shown in the figure, e.g. notify a subscribed NEF, ...
12. The UDM sends update response to the AMF and locally deletes the data retrieved in step 9.

NOTE: When a previously received Location Header or Callback URI is used for a subsequent UDM contact, the authority part may need to be replaced to point to the selected UDM.

Figure B-4 shows a scenario where an AF requests a subscription for all UEs (any UE) for a given network event. The NEF discovers all UDM NFs providing the necessary service to perform a bulk subscription. If one or several UDM Group IDs are received, NEF selects only one instance of UDM for each Group ID in order to perform the bulk subscription.

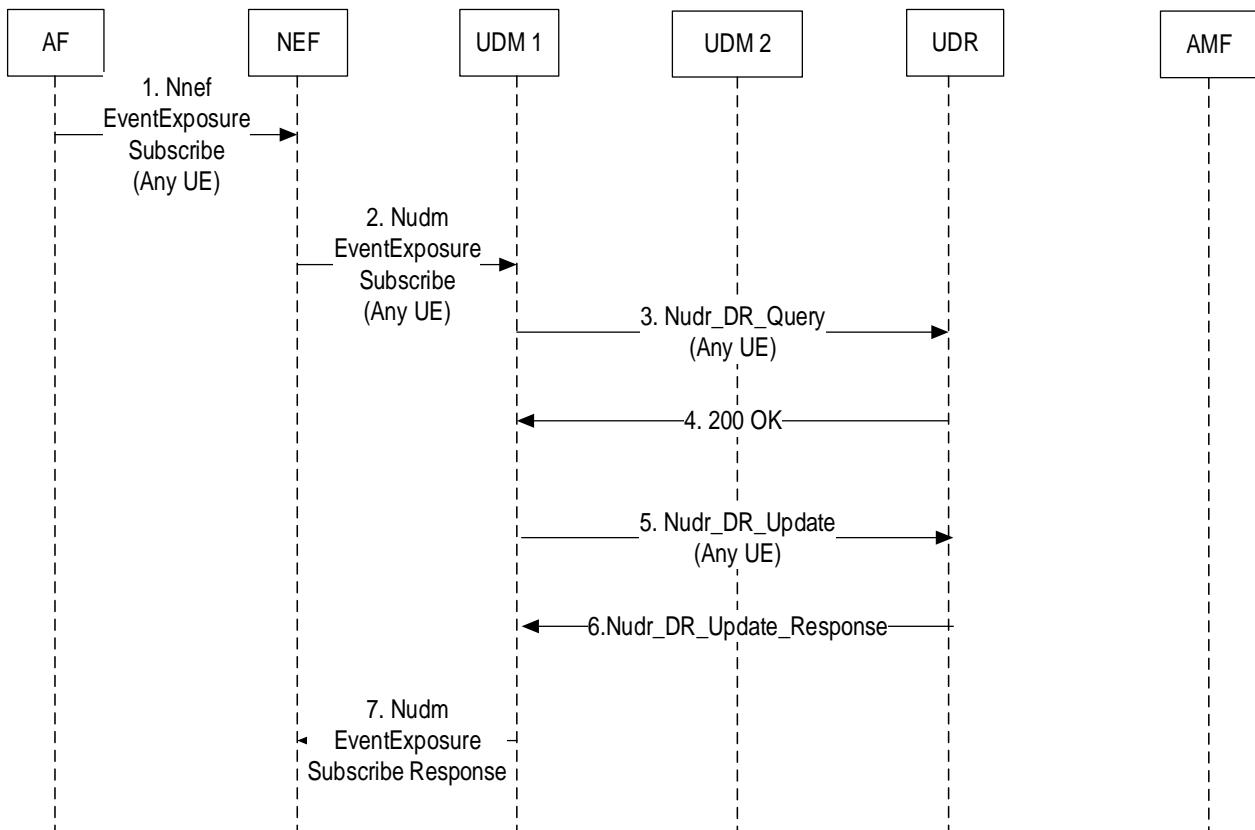

Figure B-4: Any UE Subscription

1. An AF subscribes to a network event (e.g. SUPI-PEI association change) for any UE (i.e. all UEs)
2. The NEF discovers (by means of NRF query) all UDM instances supporting the required service (e.g. nudm-ee). The NEF selects an UDM instance (e.g. UDM 1) from each UDM Group ID discovered (UDM 1 and UDM 2 are in the same UDM Group ID) and sends the subscribe request. The NEF also stores the UDM Group ID information to select a UDM for subsequent subscriptions.
- 3-4. The UDM retrieves data from the UDR for group of UEs, e.g. to be able to perform required plausibility checks
- 5-6. The UDM stores data for group of UEs in the UDR.
7. The UDM acknowledges the NEF subscription request. The UDM locally deletes the data retrieved in step 3.

Steps 7-12 in Figure B-3 are performed. As result of the subscription, NEF is notified by UDM 2 (change of PEI). Subsequently, when the event occurs for any UE (within the SUPI range, if applicable, served by the UDM Group ID), NEF is notified by either UDM1 or UDM 2.

Annex C (informative): SUCI encoding

The structure of the Subscription Concealed Identifier (SUCI) is defined in 3GPP TS 23.003 [8].

When SUCI needs to be sent as a character string (e.g. as a string in a JSON payload of any of the service operations defined in the APIs defined in this specification), the SUCI is composed as an UTF-8 character string, where the different components are separated by the "minus" character "-" (UTF-8 0x2D).

These components shall be formatted as follows:

- 1) SUPI Type: a single decimal digit, from 0 to 7, formatted as a single UTF-8 character (UTF-8 0x30 to 0x37)

2) Home Network Identifier.

When the SUPI Type is an IMSI, the Home Network Identifier consists on 2 components: MCC and MNC, separated by the "minus" character; these components are formatted as a string of 3 characters for MCC and a string of 2 or 3 characters for MNC (UTF-8 0x30 to 0x39).

When the SUPI type is a Network Specific Identifier, the Home Network Identifier consists of a string of characters with a variable length, formatted as an UTF-8 character string.

- 3) Routing Indicator, consisting of 1 to 4 decimal digits formatted as a string of 1 to 4 characters (UTF-8 0x30 to 0x39).
- 4) Protection Scheme Identifier, consisting in a value in the range of 0 to 15, representing a single hexadecimal digit, formatted as a single UTF-8 character (UTF-8 0x30 to 0x39, or 0x41 to 0x46, or 0x61 to 0x66).
- 5) Home Network Public Key Identifier, consisting in a value in the range 0 to 255, formatted as a sequence of 1 to 3 decimal digits, formatted of 1 to 3 UTF-8 characters (UTF-8 0x30 to 0x39).
- 6) Scheme Output, consisting of a string of UTF-8 characters with a variable length, or a sequence of hexadecimal digits, dependent on the used protection scheme. It represents the output of a public key protection scheme specified in Annex C of 3GPP TS 33.501 [6] or the output of a protection scheme specified by the HPLMN.

EXAMPLES:

- SUPI is IMSI-based; MCC=123, MNC=45, MSIN: 0123456789

SUPI type: 0 (IMSI)

Routing Identifier: 012

Protection Scheme: 0 (NULL scheme)

Home Network Public Key Identifier: 0

Scheme output = MSIN (cleartext)

SUCI UTF-8 string:

"0-123-45-012-0-0-0123456789"

- SUPI is IMSI-based, MCC=123, MNC=45, MSIN: 9876543210

SUPI type: 0 (IMSI)

Routing Identifier: 0002

Protection Scheme: 1 (Profile A)

Home Network Public Key Identifier: 17

Scheme output = ECC ephemeral public key (32 octets, first bolded part below) + Encrypted MSIN (10 octets, italic part below) + MAC tag (8 octets, last bolded part below) = 50 octets = 100 hexadecimal characters (NOTE: the encrypted content below is fictitious).

SUCI UTF-8 string:

"0-123-45-0002-1-17-
e9b9916c911f448d8792e6b2f387f85d3ecab9040049427d9edbb5431b0bc711023be6a057f34956ba21b45d936238
aebeb7"

- SUPI is NAI-based, SUPI = alice@example.com

SUPI type = 1 (Network Specific Identifier)

Routing Identifier: 84

Protection Scheme: 2 (Profile B)

Home Network Public Key Identifier: 250

Scheme output = ECC ephemeral public key (33 octets, first bolded part below) + Encrypted username of NAI (5 octets, italic part below) + MAC tag (8 octets, last bolded part below) = 46 octets = 92 hexadecimal characters (NOTE: the encrypted content below is fictitious)

SUCI UTF-8 string:

"1-example.com-84-2-250-
e9b9916c911f448d8792e6b2f387f85d3ecab9040049427d9edbb5431b0bc71195023be6a057b45d936238aeb7"

Annex D (informative): Change history

Change history							
Date	Meeting	TDoc	CR	Rev	Cat	Subject/Comment	New version
2017-10	CT4#80	C4-175320				TS skeleton	0.1.0
2017-10	CT4#80	C4-175362				Implementation of pCRs agreed at CT4#80.	0.2.0
2017-12	CT4#81	C4-176150 C4-176153 C4-176423 C4-176365 C4-176424 C4-176425				Implementation of pCRs agreed at CT4#81	0.3.0
2018-01	CT4#82	C4-181277 C4-181278 C4-181239 C4-181241 C4-181245 C4-181280 C4-181282 C4-181131 C4-181247 C4-181284 C4-181250 C4-181273 C4-181252 C4-181254				Implementation of pCRs agreed at CT4#82	0.4.0
2018-03	CT4#83	C4-182178 C4-182270 C4-182354 C4-182352 C4-182274 C4-182400 C4-182402 C4-182356 C4-182351 C4-182401 C4-182268				Implementation of pCRs agreed at CT4#83	0.5.0
2018-04	CT4#84	C4-183124 C4-183143 C4-183221 C4-183225 C4-183228 C4-183230 C4-183232 C4-183234 C4-183244 C4-183300 C4-183302 C4-183304 C4-183305 C4-183306 C4-183307 C4-183308 C4-183374 C4-183381 C4-183382 C4-183425 C4-183427 C4-183430 C4-183480 C4-183483 C4-183486 C4-183508 C4-183509				Implementation of pCRs agreed at CT4#84	0.6.0
2018-05						"yaml files" added into the zip-file	0.6.1

2018-05	CT4#85	C4-184351 C4-184356 C4-184210 C4-184211 C4-184358 C4-184359 C4-184558 C4-184559 C4-184381 C4-184556 C4-184423 C4-184557 C4-184310 C4-184572 C4-184622				Implementation of pCRs agreed at CT4#85	0.7.0
2018-06	CT#80	CP-181001				Presented for information and approval.	1.0.0
2018-06	CT#80	CP-181196				Approved in CT#80	15.0.0
2018-09	CT#81	CP-182056	0001	3	B	UDM receives notification of target/new AMF after AMF planned removal	15.1.0
2018-09	CT#81	CP-182170	0002	1	F	DeregistrationData alignment with stage 2	15.1.0
2018-09	CT#81	CP-182172	0003	6	F	Event subscription alignment with stage 2	15.1.0
2018-09	CT#81	CP-182056	0005	5	F	Data Change Notification	15.1.0
2018-09	CT#81	CP-182056	0004	1	F	NfInstanceId	15.1.0
2018-09	CT#81	CP-182049	0006	3	F	UDM support for dynamic 5QIs and for standard 5QIs whose default QoS characteristics are overridden	15.1.0
2018-09	CT#81	CP-182068	0007	4	B	Add support for 5G Trace to Nudm_SDM	15.1.0
2018-09	CT#81	CP-182056	0008	4	B	Shared Data	15.1.0
2018-09	CT#81	CP-182056	0009	1	F	Feature Negotiation	15.1.0
2018-09	CT#81	CP-182056	0010	2	F	Nudm_SDM_Get	15.1.0
2018-09	CT#81	CP-182056	0011	1	F	Allowing multiple monitoring reports in a single event occurrence notification	15.1.0
2018-09	CT#81	CP-182056	0015	1	F	UDM Data change notification	15.1.0
2018-09	CT#81	CP-182056	0016	3	F	Nudm_SDM_Info Service Operation Description	15.1.0
2018-09	CT#81	CP-182056	0022		F	Authentication Info Result	15.1.0
2018-09	CT#81	CP-182056	0025	2	B	Add MicoAllowed in am-data	15.1.0
2018-09	CT#81	CP-182056	0026	2	B	Introduction of PLMN Id in UECM & UE Authentication Services	15.1.0
2018-09	CT#81	CP-182056	0028	2	F	Mobility Restriction	15.1.0
2018-09	CT#81	CP-182056	0029	1	F	SMSF addresses	15.1.0
2018-09	CT#81	CP-182056	0030	4	F	SMS subscription data	15.1.0
2018-09	CT#81	CP-182056	0031		F	Clause Numbering	15.1.0
2018-09	CT#81	CP-182056	0032	1	F	Formal OpenAPI corrections	15.1.0
2018-09	CT#81	CP-182056	0033		F	GMLC	15.1.0
2018-09	CT#81	CP-182056	0034		F	AUSF Instance Id	15.1.0
2018-09	CT#81	CP-182056	0036	2	F	Avoid stale sdm-subscriptions	15.1.0
2018-09	CT#81	CP-182056	0037		B	Nudm_SDM retrieval of SMS Management Subscription data	15.1.0
2018-09	CT#81	CP-182056	0038	1	F	Nudm_UECM Errors	15.1.0
2018-09	CT#81	CP-182056	0039		F	P-CSCF restoration callbacks	15.1.0
2018-09	CT#81	CP-182056	0040	1	F	Nudm_UEAU Errors	15.1.0
2018-09	CT#81	CP-182056	0041	1	F	Nudm_EE Errors	15.1.0
2018-09	CT#81	CP-182056	0042	1	F	Nudm_PP Errors	15.1.0
2018-09	CT#81	CP-182056	0043	2	F	UDM Group	15.1.0
2018-09	CT#81	CP-182056	0045	1	F	SUCI coding	15.1.0
2018-09	CT#81	CP-182056	0046	2	F	BackUp AMF Info	15.1.0
2018-09	CT#81	CP-182056	0047	2	F	Interworking with EPS indication	15.1.0
2018-09	CT#81	CP-182171	0048	2	F	Nudm_SDM_Subscribe for SMF	15.1.0
2018-09	CT#81	CP-182056	0050	1	F	User Plane Security Policy	15.1.0
2018-09	CT#81	CP-182056	0051		F	Description of Structured data types	15.1.0
2018-09	CT#81	CP-182056	0054	1	F	Provide DNN with LADN indicator per NSSAI	15.1.0
2018-09	CT#81	CP-182056	0055		F	UE Context In SMF Data Retrieval	15.1.0
2018-09	CT#81	CP-182056	0057		F	Time Stamp in EE Notify	15.1.0
2018-09	CT#81	CP-182056	0058		F	Naming Conventions	15.1.0
2018-09	CT#81	CP-182056	0059		F	Storage and retrieval of PGW FQDN	15.1.0
2018-09	CT#81	CP-182056	0060		F	API version number update	15.1.0
2018-12	CT#82	CP-183014	0061	1	F	Remove key attributes from map elements	15.2.0
2018-12	CT#82	CP-183014	0062	2	F	imsVoPS for non-3GPP access	15.2.0
2018-12	CT#82	CP-183014	0063	2	F	Internal-Group Identifier	15.2.0
2018-12	CT#82	CP-183014	0064	2	F	Stateless AMF support updates	15.2.0
2018-12	CT#82	CP-183014	0065	2	F	Location Reporting Configuration in Nudm_EE service	15.2.0
2018-12	CT#82	CP-183014	0066	1	F	Nudm_SDM Errors	15.2.0
2018-12	CT#82	CP-183164	0067	4	F	Shared Data completion	15.2.0
2018-12	CT#82	CP-183014	0068	1	F	Cardinality for arrays	15.2.0
2018-12	CT#82	CP-183014	0069	5	F	Single Registration Flag	15.2.0

2018-12	CT#82	CP-183014	0070	2	F	Adding headers for cache control and conditional request to the Nudm_SubscriberDataManagement Service API	15.2.0
2018-12	CT#82	CP-183014	0072	3	F	Initial Registration	15.2.0
2018-12	CT#82	CP-183014	0076	1	F	Correcting Nudm_UEAuthentication service description	15.2.0
2018-12	CT#82	CP-183014	0078	1	F	Add Serving Network Name to AuthEvent	15.2.0
2018-12	CT#82	CP-183014	0079	2	F	Remove PLMN-ID from AMF registration in OpenAPI	15.2.0
2018-12	CT#82	CP-183014	0080		F	Make ARP mandatory in QoS parameters	15.2.0
2018-12	CT#82	CP-183014	0081	1	F	RAT type	15.2.0
2018-12	CT#82	CP-183014	0082	1	F	Correction in UDM error and response codes	15.2.0
2018-12	CT#82	CP-183014	0083	1	F	Retrieving UE SMSF Context with its own URI	15.2.0
2018-12	CT#82	CP-183014	0084	1	F	Data type associated with Subscribed Default QoS for Default QoS Flow	15.2.0
2018-12	CT#82	CP-183014	0085	1	F	Alignment of pattern for External identifier	15.2.0
2018-12	CT#82	CP-183014	0086	1	F	Callback URI for Deregistration Notification	15.2.0
2018-12	CT#82	CP-183014	0088	1	F	Static Ip Address in DNN Configuration	15.2.0
2018-12	CT#82	CP-183014	0090		F	ImsVoPs type and attribute name correction	15.2.0
2018-12	CT#82	CP-183014	0091	1	F	Clarification on nullable attributes in AmfRegistration types	15.2.0
2018-12	CT#82	CP-183014	0092		F	Retrieval of multiple datasets	15.2.0
2018-12	CT#82	CP-183014	0094	2	F	DeRegistration Reason: Re-registration Required	15.2.0
2018-12	CT#82	CP-183014	0095		F	APIRoot Clarification	15.2.0
2018-12	CT#82	CP-183014	0098		F	Shared Data Ids	15.2.0
2018-12	CT#82	CP-183014	0099	1	F	Subscription lifetime	15.2.0
2018-12	CT#82	CP-183014	0100	3	F	Secured packet in SorInfo	15.2.0
2018-12	CT#82	CP-183014	0103	1	F	Abbreviations	15.2.0
2018-12	CT#82	CP-183014	0104	1	F	Nudm_UECM_Deregistration clarification	15.2.0
2018-12	CT#82	CP-183014	0105		F	Location Header	15.2.0
2018-12	CT#82	CP-183014	0107	1	F	SUCI Encoding	15.2.0
2018-12	CT#82	CP-183014	0108	1	F	S-NSSAI information in SmfRegistration	15.2.0
2018-12	CT#82	CP-183014	0109		F	SUCI NAI Clarification	15.2.0
2018-12	CT#82	CP-183014	0110	1	F	Bulk subscriptions in UDM NF correction	15.2.0
2018-12	CT#82	CP-183014	0111	1	F	Introduction of Barring	15.2.0
2018-12	CT#82	CP-183014	0112		F	UDM Corrections	15.2.0
2018-12	CT#82	CP-183014	0114	2	F	Optionality of OAuth2	15.2.0
2018-12	CT#82	CP-183014	0115		F	Implement MCS priority indicator	15.2.0
2018-12	CT#82	CP-183014	0116		F	API version	15.2.0
2018-12	CT#82	CP-183014	0117	1	F	Shared Authentication Subscription	15.2.0
2018-12	CT#82	CP-183014	0118		F	ExternalDocs update	15.2.0
2018-12						'TS29505_Nudr_DataRepository.yaml' changed to 'TS29505_Subscription_Data.yaml' in Nudm_SDM API	15.2.1

History

Document history		
V15.0.0	July 2018	Publication
V15.1.0	October 2018	Publication
V15.2.1	April 2019	Publication