

ETSI TS 129 510 V15.1.0 (2018-10)



**5G;
5G System;
Network function repository services;
Stage 3
(3GPP TS 29.510 version 15.1.0 Release 15)**



Reference

RTS/TSGC-0429510vf10

Keywords

5G

ETSI

650 Route des Lucioles
F-06921 Sophia Antipolis Cedex - FRANCE

Tel.: +33 4 92 94 42 00 Fax: +33 4 93 65 47 16

Siret N° 348 623 562 00017 - NAF 742 C
Association à but non lucratif enregistrée à la
Sous-Préfecture de Grasse (06) N° 7803/88

Important notice

The present document can be downloaded from:

<http://www.etsi.org/standards-search>

The present document may be made available in electronic versions and/or in print. The content of any electronic and/or print versions of the present document shall not be modified without the prior written authorization of ETSI. In case of any existing or perceived difference in contents between such versions and/or in print, the only prevailing document is the print of the Portable Document Format (PDF) version kept on a specific network drive within ETSI Secretariat.

Users of the present document should be aware that the document may be subject to revision or change of status.

Information on the current status of this and other ETSI documents is available at

<https://portal.etsi.org/TB/ETSIDeliverableStatus.aspx>

If you find errors in the present document, please send your comment to one of the following services:

<https://portal.etsi.org/People/CommiteeSupportStaff.aspx>

Copyright Notification

No part may be reproduced or utilized in any form or by any means, electronic or mechanical, including photocopying and microfilm except as authorized by written permission of ETSI.

The content of the PDF version shall not be modified without the written authorization of ETSI.

The copyright and the foregoing restriction extend to reproduction in all media.

© ETSI 2018.

All rights reserved.

DECT™, **PLUGTESTS™**, **UMTS™** and the ETSI logo are trademarks of ETSI registered for the benefit of its Members.

3GPP™ and **LTE™** are trademarks of ETSI registered for the benefit of its Members and of the 3GPP Organizational Partners.

oneM2M logo is protected for the benefit of its Members.

GSM® and the GSM logo are trademarks registered and owned by the GSM Association.

Intellectual Property Rights

Essential patents

IPRs essential or potentially essential to normative deliverables may have been declared to ETSI. The information pertaining to these essential IPRs, if any, is publicly available for **ETSI members and non-members**, and can be found in ETSI SR 000 314: *"Intellectual Property Rights (IPRs); Essential, or potentially Essential, IPRs notified to ETSI in respect of ETSI standards"*, which is available from the ETSI Secretariat. Latest updates are available on the ETSI Web server (<https://ipr.etsi.org/>).

Pursuant to the ETSI IPR Policy, no investigation, including IPR searches, has been carried out by ETSI. No guarantee can be given as to the existence of other IPRs not referenced in ETSI SR 000 314 (or the updates on the ETSI Web server) which are, or may be, or may become, essential to the present document.

Trademarks

The present document may include trademarks and/or tradenames which are asserted and/or registered by their owners. ETSI claims no ownership of these except for any which are indicated as being the property of ETSI, and conveys no right to use or reproduce any trademark and/or tradename. Mention of those trademarks in the present document does not constitute an endorsement by ETSI of products, services or organizations associated with those trademarks.

Foreword

This Technical Specification (TS) has been produced by ETSI 3rd Generation Partnership Project (3GPP).

The present document may refer to technical specifications or reports using their 3GPP identities, UMTS identities or GSM identities. These should be interpreted as being references to the corresponding ETSI deliverables.

The cross reference between GSM, UMTS, 3GPP and ETSI identities can be found under <http://webapp.etsi.org/key/queryform.asp>.

Modal verbs terminology

In the present document "**shall**", "**shall not**", "**should**", "**should not**", "**may**", "**need not**", "**will**", "**will not**", "**can**" and "**cannot**" are to be interpreted as described in clause 3.2 of the [ETSI Drafting Rules](#) (Verbal forms for the expression of provisions).

"**must**" and "**must not**" are **NOT** allowed in ETSI deliverables except when used in direct citation.

Contents

Intellectual Property Rights	2
Foreword.....	2
Modal verbs terminology.....	2
Foreword.....	7
Introduction	7
1 Scope	8
2 References	8
3 Definitions and abbreviations.....	9
3.1 Definitions	9
3.2 Abbreviations	9
4 Overview	9
5 Services Offered by the NRF	10
5.1 Introduction	10
5.2 Nnrf_NFManagement Service.....	10
5.2.1 Service Description.....	10
5.2.2 Service Operations	10
5.2.2.1 Introduction	10
5.2.2.2 NFRegister	11
5.2.2.2.1 General	11
5.2.2.2.2 NF (other than NRF) registration to NRF.....	11
5.2.2.2.3 NRF registration to another NRF	12
5.2.2.3 NFUpdate.....	12
5.2.2.3.1 General	12
5.2.2.3.2 NF Heart-Beat	13
5.2.2.4 NFDeregister.....	14
5.2.2.4.1 General	14
5.2.2.5 NFStatusSubscribe	14
5.2.2.5.1 General	14
5.2.2.5.2 Subscription to NF Instances in the same PLMN.....	15
5.2.2.5.3 Subscription to NF Instances in a different PLMN	15
5.2.2.6 NFStatusNotify	16
5.2.2.6.1 General	16
5.2.2.6.2 Notification from NRF in the same PLMN	16
5.2.2.6.3 Notification from NRF in a different PLMN.....	17
5.2.2.7 NFStatusUnSubscribe	17
5.2.2.7.1 General	17
5.2.2.7.2 Subscription removal in the same PLMN.....	17
5.2.2.7.3 Subscription removal in a different PLMN	17
5.3 Nnrf_NFDiscovery Service	18
5.3.1 Service Description.....	18
5.3.2 Service Operations	18
5.3.2.1 Introduction	18
5.3.2.2 NFDdiscover	19
5.3.2.2.1 General	19
5.3.2.2.2 Service Discovery in the same PLMN.....	19
5.3.2.2.3 Service Discovery in a different PLMN	19
5.3.2.2.4 Service Discovery with intermediate redirecting NRF.....	20
5.3.2.2.5 Service Discovery with intermediate forwarding NRF	21
5.4 OAuth2 Authorization Service	22
5.4.1 Service Description.....	22
5.4.2 Service Operations	22
5.4.2.1 Introduction.....	22
5.4.2.2 Access Token Request	22

5.4.2.2.1	General	22
6	API Definitions	23
6.1	Nnrf_NFManagement Service API	23
6.1.1	API URI	23
6.1.2	Usage of HTTP	23
6.1.2.1	General	23
6.1.2.2	HTTP Standard Headers	23
6.1.2.2.1	General	23
6.1.2.2.2	Content type	23
6.1.2.3	HTTP custom headers	24
6.1.2.3.1	General	24
6.1.3	Resources	24
6.1.3.1	Overview	24
6.1.3.2	Resource: nf-instances (Store)	25
6.1.3.2.1	Description	25
6.1.3.2.2	Resource Definition	25
6.1.3.2.3	Resource Standard Methods	25
6.1.3.2.3.1	GET	25
6.1.3.2.4	Resource Custom Operations	26
6.1.3.3	Resource: nf-instance (Document)	26
6.1.3.3.1	Description	26
6.1.3.3.2	Resource Definition	26
6.1.3.3.3	Resource Standard Methods	26
6.1.3.3.3.1	GET	26
6.1.3.3.3.2	PUT	27
6.1.3.3.3.3	PATCH	28
6.1.3.3.3.4	DELETE	28
6.1.3.4	Resource: subscriptions (Collection)	29
6.1.3.4.1	Description	29
6.1.3.4.2	Resource Definition	29
6.1.3.4.3	Resource Standard Methods	29
6.1.3.4.3.1	POST	29
6.1.3.5	Resource: subscription (Document)	30
6.1.3.5.1	Description	30
6.1.3.5.2	Resource Definition	30
6.1.3.5.3	Resource Standard Methods	30
6.1.3.5.3.1	DELETE	30
6.1.4	Custom Operations without associated resources	31
6.1.5	Notifications	31
6.1.5.1	General	31
6.1.5.2	NF Instance Status Notification	31
6.1.5.2.1	Description	31
6.1.5.2.2	Notification Definition	31
6.1.6	Data Model	32
6.1.6.1	General	32
6.1.6.2	Structured data types	33
6.1.6.2.1	Introduction	33
6.1.6.2.2	Type: NFProfile	34
6.1.6.2.3	Type: NFService	36
6.1.6.2.4	Type: DefaultNotificationSubscription	38
6.1.6.2.5	Type: IpEndPoint	38
6.1.6.2.6	Type: UdrInfo	38
6.1.6.2.7	Type: UdmInfo	38
6.1.6.2.8	Type: AusfInfo	39
6.1.6.2.9	Type: SupiRange	39
6.1.6.2.10	Type: IdentityRange	40
6.1.6.2.11	Type: AmfInfo	40
6.1.6.2.12	Type: SmfInfo	41
6.1.6.2.13	Type: UpfInfo	41
6.1.6.2.14	Type: SnsaiUpfInfoItem	41
6.1.6.2.15	Type: DnnUpfInfoItem	41

6.1.6.2.16	Type: SubscriptionData	42
6.1.6.2.17	Type: NotificationData	43
6.1.6.2.18	Type: NFRegistrationData	43
6.1.6.2.19	Type: NFSERVICEVersion	43
6.1.6.2.20	Type: PcfInfo	43
6.1.6.2.21	Type: BsflInfo	43
6.1.6.2.22	Type: Ipv4AddressRange	44
6.1.6.2.23	Type: Ipv6PrefixRange	44
6.1.6.2.24	Type: InterfaceUpfInfoItem	44
6.1.6.2.25	Type: UriList	44
6.1.6.2.26	Type: N2InterfaceAmfInfo	44
6.1.6.2.27	Type: TaiRange	45
6.1.6.2.28	Type: TacRange	45
6.1.6.3	Simple data types and enumerations	45
6.1.6.3.1	Introduction	45
6.1.6.3.2	Simple data types	45
6.1.6.3.3	Enumeration: NFType	46
6.1.6.3.4	Enumeration: NotificationType	46
6.1.6.3.5	Enumeration: TransportProtocol	46
6.1.6.3.6	Enumeration: NotificationEventType	47
6.1.6.3.7	Enumeration: NFStatus	47
6.1.6.3.8	Enumeration: DataSetId	47
6.1.6.3.9	Enumeration: UPInterfaceType	47
6.1.6.3.10	Relation Types	47
6.1.6.3.10.1	General	47
6.1.6.3.11	Enumeration: ServiceName	48
6.1.6.3.12	Enumeration: NFSERVICEStatus	48
6.1.7	Error Handling	48
6.1.7.1	General	48
6.1.7.2	Protocol Errors	48
6.1.7.3	Application Errors	48
6.1.8	Security	49
6.2	Nnrf_NFDISCOVERY Service API	49
6.2.1	API URI	49
6.2.2	Usage of HTTP	49
6.2.2.1	General	49
6.2.2.2	HTTP Standard Headers	49
6.2.2.2.1	General	49
6.2.2.2.2	Content type	49
6.2.2.2.3	Cache-Control	49
6.2.2.2.4	ETag	50
6.2.2.2.5	If-None-Match	50
6.2.2.3	HTTP custom headers	50
6.2.2.3.1	General	50
6.2.3	Resources	50
6.2.3.1	Overview	50
6.2.3.2	Resource: nf-instances (Store)	50
6.2.3.2.1	Description	50
6.2.3.2.2	Resource Definition	50
6.2.3.2.3	Resource Standard Methods	51
6.2.3.2.3.1	GET	51
6.2.3.2.4	Resource Custom Operations	55
6.2.4	Custom Operations without associated resources	55
6.2.5	Notifications	55
6.2.6	Data Model	55
6.2.6.1	General	55
6.2.6.2	Structured data types	56
6.2.6.2.1	Introduction	56
6.2.6.2.2	Type: SearchResult	56
6.2.6.2.3	Type: NFProfile	57
6.2.6.2.4	Type: NFSERVICE	58
6.2.6.3	Simple data types and enumerations	58

6.2.6.3.1	Introduction	58
6.2.6.3.2	Simple data types.....	58
6.2.7	Error Handling	59
6.2.7.1	General	59
6.2.7.2	Protocol Errors	59
6.2.7.3	Application Errors	59
6.2.8	Security	59
6.3	OAuth2.0 Authorization Service API.....	59
6.3.1	General.....	59
6.3.2	API URI.....	59
6.3.3	Usage of HTTP	59
6.3.3.1	General	59
6.3.3.2	HTTP standard headers	60
6.3.3.2.1	General	60
6.3.3.2.2	Content type	60
6.3.3.3	HTTP custom headers	60
6.3.3.3.1	General	60
6.3.4	Custom Operation without Associated Resources	60
6.3.4.1	Overview	60
6.3.4.2	Operation: Access Token Request	60
6.3.4.2.1	Description	60
6.3.4.2.2	Operation Definition.....	60
6.3.5	Data Model	61
6.3.5.1	General	61
6.3.5.2	Structured data types	61
6.3.5.2.1	Introduction	61
6.3.5.2.2	Type: AccessTokenReq.....	62
6.3.5.2.3	Type: AccessTokenRsp	62
6.3.5.2.4	Type: AccessTokenClaims	63
6.3.5.3	Simple data types and enumerations	63
6.3.5.3.1	Introduction	63
6.3.5.3.2	Simple data types.....	63
6.3.5.3.3	Enumeration: GrantType	63
Annex A (normative):	OpenAPI specification.....	64
A.1	General	64
A.2	Nnrf_NFManagement API.....	64
A.3	Nnrf_NFDiscovery API	76
A.4	NRF OAuth2 Authorization	81
Annex B (informative):	Change history	84
History		86

Foreword

This Technical Specification has been produced by the 3rd Generation Partnership Project (3GPP).

The contents of the present document are subject to continuing work within the TSG and may change following formal TSG approval. Should the TSG modify the contents of the present document, it will be re-released by the TSG with an identifying change of release date and an increase in version number as follows:

Version x.y.z

where:

- x the first digit:
 - 1 presented to TSG for information;
 - 2 presented to TSG for approval;
 - 3 or greater indicates TSG approved document under change control.
- y the second digit is incremented for all changes of substance, i.e. technical enhancements, corrections, updates, etc.
- z the third digit is incremented when editorial only changes have been incorporated in the document.

Introduction

This clause is optional. If it exists, it is always the second unnumbered clause.

1 Scope

The present document specifies the stage 3 protocol and data model for the Nnrf Service Based Interface. It provides stage 3 protocol definitions and message flows, and specifies the API for each service offered by the NRF.

The 5G System stage 2 architecture and procedures are specified in 3GPP TS 23.501 [2] and 3GPP TS 23.502 [3].

The Technical Realization of the Service Based Architecture and the Principles and Guidelines for Services Definition are specified in 3GPP TS 29.500 [4] and 3GPP TS 29.501 [5].

2 References

The following documents contain provisions which, through reference in this text, constitute provisions of the present document.

- References are either specific (identified by date of publication, edition number, version number, etc.) or non-specific.
- For a specific reference, subsequent revisions do not apply.
- For a non-specific reference, the latest version applies. In the case of a reference to a 3GPP document (including a GSM document), a non-specific reference implicitly refers to the latest version of that document *in the same Release as the present document*.

- [1] 3GPP TR 21.905: "Vocabulary for 3GPP Specifications".
- [2] 3GPP TS 23.501: "System Architecture for the 5G System; Stage 2".
- [3] 3GPP TS 23.502: "Procedures for the 5G System; Stage 2".
- [4] 3GPP TS 29.500: "5G System; Technical Realization of Service Based Architecture; Stage 3".
- [5] 3GPP TS 29.501: "5G System; Principles and Guidelines for Services Definition; Stage 3".
- [6] 3GPP TS 29.518: "5G System; Access and Mobility Management Services; Stage 3".
- [7] 3GPP TS 29.571: "5G System; Common Data Types for Service Based Interfaces; Stage 3".
- [8] ECMA-262: "ECMAScript® Language Specification", <https://www.ecma-international.org/ecma-262/5.1/>.
- [9] IETF RFC 7540: "Hypertext Transfer Protocol Version 2 (HTTP/2)".
- [10] OpenAPI Initiative, "OpenAPI 3.0.0 Specification", <https://github.com/OAI/OpenAPI-Specification/blob/master/versions/3.0.0.md>.
- [11] IETF RFC 7807: "Problem Details for HTTP APIs".
- [12] 3GPP TS 23.003: "Numbering, Addressing and Identification".
- [13] IETF RFC 6902: "JavaScript Object Notation (JSON) Patch".
- [14] IETF RFC 6901: "JavaScript Object Notation (JSON) Pointer".
- [15] 3GPP TS 33.501: "Security architecture and procedures for 5G system".
- [16] IETF RFC 6749: "The OAuth 2.0 Authorization Framework".
- [17] IETF RFC 3986: "Uniform Resource Identifier (URI): Generic Syntax".
- [18] IETF RFC 4122: "A Universally Unique Identifier (UUID) URN Namespace".
- [19] IETF RFC 7232: "Hypertext Transfer Protocol (HTTP/1.1): Conditional Requests".
- [20] IETF RFC 7234: "Hypertext Transfer Protocol (HTTP/1.1): Caching".

- [21] 3GPP TS 29.244: "Interface between the Control Plane and the User Plane Nodes; Stage 3".
- [22] IETF RFC 8259: "The JavaScript Object Notation (JSON) Data Interchange Format".
- [23] IETF RFC 2782: "A DNS RR for specifying the location of services (DNS SRV)".
- [24] IETF RFC 7515: "JSON Web Signature (JWS)".
- [25] IETF RFC 7519: "JSON Web Token (JWT)".
- [26] W3C HTML 4.01 Specification, <https://www.w3.org/TR/2018/SPSD-html401-20180327/>.
- [27] 3GPP TS 23.527: "5G System; Restoration Procedures; Stage 2".

3 Definitions and abbreviations

3.1 Definitions

For the purposes of the present document, the terms and definitions given in 3GPP TR 21.905 [1] and the following apply. A term defined in the present document takes precedence over the definition of the same term, if any, in 3GPP TR 21.905 [1].

3.2 Abbreviations

For the purposes of the present document, the abbreviations given in 3GPP TR 21.905 [1] and the following apply. An abbreviation defined in the present document takes precedence over the definition of the same abbreviation, if any, in 3GPP TR 21.905 [1].

5GC	5G Core Network
CHF	Charging Function
NF	Network Function
NRF	NF Repository Function

4 Overview

The Network Function (NF) Repository Function (NRF) is the network entity in the 5G Core Network (5GC) supporting the following functionality:

- Maintains the NF profile of available NF instances and their supported services;
- Allows other NF instances to subscribe to, and get notified about, the registration in NRF of new NF instances of a given type;
- Supports service discovery function. It receives NF Discovery Requests from NF instances, and provides the information of the available NF instances fulfilling certain criteria (e.g., supporting a given service).

Figure 4-1 shows the reference architecture for the 5GC, with focus on the NRF:

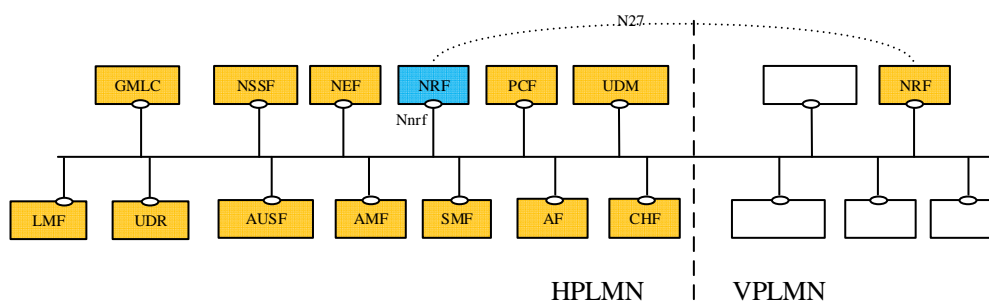

Figure 4-1: 5G System architecture

For the sake of clarity, the NRF is never depicted in reference point representation figures, given that the NRF interacts with every other NF in the 5GC. As an exception, in the roaming case, the reference point between the vNRF and the hNRF is named as N27. The reference point name of N27 is used only for representation purposes, but its functionality is included in the services offered by the Nnrf Service-Based Interface.

5 Services Offered by the NRF

5.1 Introduction

The NRF offers to other NFs the following services:

- Nnrf_NFManagement
- Nnrf_NFDiscovery
- OAuth2 Authorization

5.2 Nnrf_NFManagement Service

5.2.1 Service Description

The Nnrf_NFManagement service allows a Network Function Instance in the serving PLMN to register, update or deregister its profile in the NRF.

It also allows an NF to subscribe to be notified of newly registered NF Instances along with their NF services.

The NF profile consists of general parameters of the NF Instance, and also the parameters of the different services exposed by the NF Instance.

5.2.2 Service Operations

5.2.2.1 Introduction

The services operations defined for the Nnrf_NFManagement service are as follows:

- **NFRegister:** It allows an NF Instance to register its NF profile in the NRF; it includes the registration of the general parameters of the NF Instance, together with the list of services exposed by the NF Instance. This service operation is not allowed to be invoked from an NRF in a different PLMN.
- **NFUpdate:** It allows an NF Instance to replace, or update partially, the parameters of its NF profile (including the parameters of the associated services) in the NRF; it also allows to add or delete individual services offered by the NF Instance. This service operation is not allowed to be invoked from an NRF in a different PLMN.
- **NFDeregister:** It allows an NF Instance to deregister its NF profile in the NRF, including the services offered by the NF Instance. This service operation is not allowed to be invoked from an NRF in a different PLMN.
- **NFStatusSubscribe:** It allows an NF Instance to subscribe to changes on the status of NF Instances registered in NRF. This service operation can be invoked by an NF Instance in a different PLMN (via the local NRF in that PLMN).
- **NFStatusNotify:** It allows the NRF to notify subscribed NF Instances of changes on the status of NF Instances. This service operation can be invoked directly between the NRF and an NF Instance in a different PLMN (without involvement of the local NRF in that PLMN).
- **NFStatusUnsubscribe:** It allows an NF Instance to unsubscribe to changes on the status of NF Instances registered in NRF. This service operation can be invoked by an NF Instance in a different PLMN (via the local NRF in that PLMN).

NOTE: The "change of status" of the NFStatus service operations can imply a request to be notified of newly registered NF Instances in NRF, or to be notified of profile changes of a specific NF Instance, or to be notified of the deregistration of an NF Instance.

The NFStatusSubscribe / NFStatusNotify / NFStatusUnsubscribe operations can be invoked by an NF Service Consumer (i.e., "source NF") requesting to be notified about events (registration, deregistration, profile change) related to an NF instance (i.e., "target NF") located in the same PLMN, or in a different PLMN.

In the description of these operations in subclauses 5.2.2.5, 5.2.2.6 and 5.2.2.7, when the NF instances are located in the same PLMN, both source NF and target NF are said to be located in the "Serving PLMN" but, in the general case, the functionality is not restricted to the PLMN that is serving a given UE, and it shall be applicable as well to any scenario in which source NF and target NFs belong to the same PLMN.

When source NF and target NF are located in different PLMNs, the source NF is said to be in the "Serving PLMN", and the target NF (and the NRF where such NF is registered) is said to be in the "Home PLMN", similarly to the scenarios described in 3GPP TS 23.502 [2], but the functionality shall be equally applicable to any scenario between any pair of PLMNs (e.g. with the source NF in the Home PLMN and the target NF in the Serving PLMN).

5.2.2.2 NFRegister

5.2.2.2.1 General

This service operation is used:

- to register an NF in the NRF by providing the NF profile of the requesting NF to the NRF, and the NRF marks the requesting NF as available to be discovered by other NFs;
- to register services associated to an existing NF Instance;
- to register NRF information in another NRF, and this information is used for forwarding or redirecting service discovery request.

5.2.2.2.2 NF (other than NRF) registration to NRF

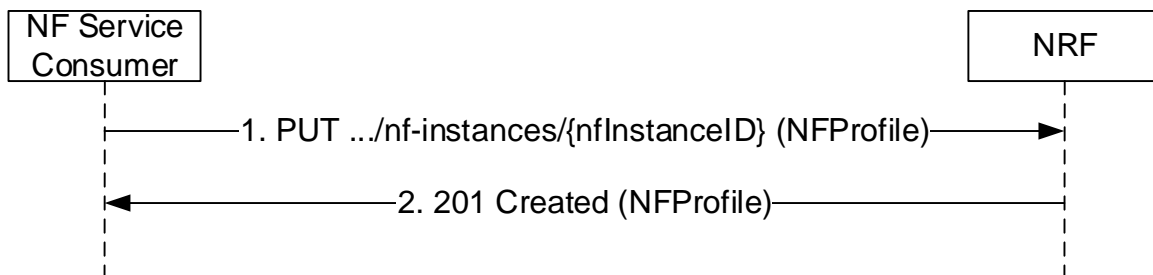

Figure 5.2.2.2.1-1: NF Instance Registration

1. The NF Service Consumer shall send a PUT request to the resource URI representing the NF Instance. The URI is determined by the NF Instance. The variable {nfInstanceID} represents an identifier, provided by the NF Service Consumer, that shall be globally unique inside the PLMN of the NRF where the NF is being registered. The format of the NF Instance ID shall be a Universally Unique Identifier (UUID) version 4, as described in IETF RFC 4122 [18].

EXAMPLE: UUID version 4: "4947a69a-f61b-4bc1-b9da-47c9c5d14b64"

The payload body of the PUT request shall contain a representation of the NF Instance to be created.

2. On success, "201 Created" shall be returned, the payload body of the PUT response shall contain the representation of the created resource and the "Location" header shall contain the URI of the created resource. Additionally, the NRF returns a "heart-beat timer" containing the number of seconds expected between two consecutive heart-beat messages from an NF Instance to the NRF (see subclause 5.2.2.3.2).

If the registration of the NF instance fails at the NRF due to errors in the encoding of the NFProfile JSON object, the NRF shall return "400 Bad Request" status code with the ProblemDetails IE providing details of the error.

If the registration of the NF instance fails at the NRF due to NRF internal errors, the NRF shall return "500 Internal Server Error" status code with the ProblemDetails IE providing details of the error.

The NRF shall allow the registration of a Network Function instance with any of the NF types described in subclause 6.1.6.3.3, and it shall also allow registration of Network Function instances with custom NF types (e.g., NF type values not defined by 3GPP, or NF type values not defined by this API version).

NOTE: When registering a custom NF in NRF, it is recommended to use a NF type name that prevents collisions with other custom NF type names, or with NF types defined in the future by 3GPP. E.g., prefixing the custom NF type name with the string "CUSTOM_".

During the registration of a Network Function instance with a custom NF type, the NF instance may provide NF-specific data (in the "customInfo" attribute), that shall be stored by the NRF as part of the NF profile of the NF instance.

5.2.2.2.3 NRF registration to another NRF

The procedure specified in subclause 5.2.2.2.2 applies. Additionally:

- a) the registering NRF shall set the nfType to "NRF" in the nfProfile;
- b) the registering NRF shall set the nfService to contain "nnrf-disc" and "nnrf-nfm" in the nfProfile;
- c) the registering NRF may include udrInfo, udmInfo, ausfInfo, amfInfo, smfInfo, upfInfo, pcfnInfo and bsfnInfo in the nfProfile, this means the registering NRF is able to provide service for discovery of NFs subject to that information;
- d) if the NRF receives an NF registration with the nfType set to "NRF", the NRF shall use the information contained in the nfProfile to target the registering NRF when forwarding or redirecting NF service discovery request.

Editor's Note: The details of the nfProfile used for NRF registration to another NRF is FFS.

5.2.2.3 NFUpdate

5.2.2.3.1 General

This service operation updates the profile of a Network Function previously registered in the NRF by providing the updated NF profile of the requesting NF to the NRF. The update operation may apply to the whole profile of the NF (complete replacement of the existing profile by a new profile), or it may apply only to a subset of the parameters of the profile (including adding/deleting/replacing services to the NF profile).

To perform a complete replacement of the NF Profile of a given NF Instance, the NF Service Consumer shall issue an HTTP PUT request, as shown in Figure 5.2.2.3.1-1:

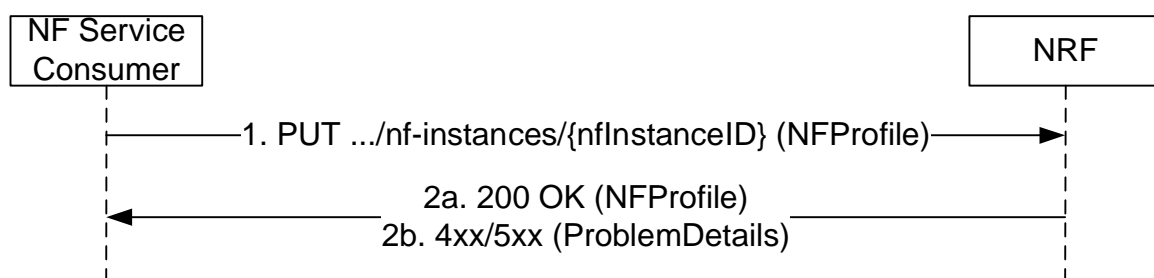

Figure 5.2.2.3.1-1: NF Profile Complete Replacement

1. The NF Service Consumer shall send a PUT request to the resource URI representing the NF Instance. The payload body of the PUT request shall contain a representation of the NF Instance to be completely replaced in the NRF.
- 2a. On success, "200 OK" shall be returned, the payload body of the PUT response shall contain the representation of the replaced resource.
- 2b. If the update of the NF instance fails at the NRF due to errors in the encoding of the NFProfile JSON object, the NRF shall return "400 Bad Request" status code with the ProblemDetails IE providing details of the error.

If the update of the NF Instance fails at the NRF due to NRF internal errors, the NRF shall return "500 Internal Server Error" status code with the ProblemDetails IE providing details of the error.

To perform a partial update of the NF Profile of a given NF Instance, the NF Service Consumer shall issue an HTTP PATCH request, as shown in Figure 5.2.2.3.1-2. This partial update shall be used to add/delete/replace individual parameters of the NF Instance, and also to add/delete/replace any of the services (and their parameters) offered by the NF Instance.

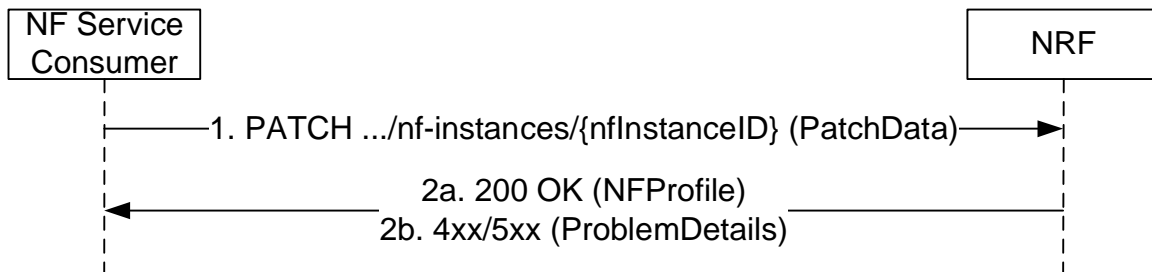

Figure 5.2.2.3.1-2: NF Profile Partial Update

1. The NF Service Consumer shall send a PATCH request to the resource URI representing the NF Instance. The payload body of the PATCH request shall contain the list of operations (add/delete/replace) to be applied to the NF Profile of the NF Instance; these operations may be directed to individual parameters of the NF Profile or to the list of services (and their parameters) offered by the NF Instances. In order to leave the NF Profile in a consistent state, all the operations specified by the PATCH request body shall be executed atomically.
- 2a. On success, "200 OK" shall be returned, the payload body of the PATCH response shall contain the representation of the replaced resource.
- 2b. If the NF Instance, identified by the "nfInstanceId", is not found in the list of registered NF Instances in the NRF's database, the NRF shall return "404 Not Found" status code with the ProblemDetails IE providing details of the error.

5.2.2.3.2 NF Heart-Beat

Each NF that has previously registered in NRF shall contact the NRF periodically (heart-beat), by invoking the NFUpdate service operation, in order to show that the NF is still operative.

The time interval at which the NRF shall be contacted is deployment-specific, and it is returned by the NRF to the NF Service Consumer as a result of a successful registration.

When the NRF detects that a given NF has not updated its profile for a configurable amount of time (longer than the heart-beat interval), the NRF changes the status of the NF to SUSPENDED and considers that the NF and its services can no longer be discovered by other NFs via the NFDiscovery service. The NRF notifies NFs subscribed to receiving notifications of changes of the NF Profile that the NF status has been changed to SUSPENDED.

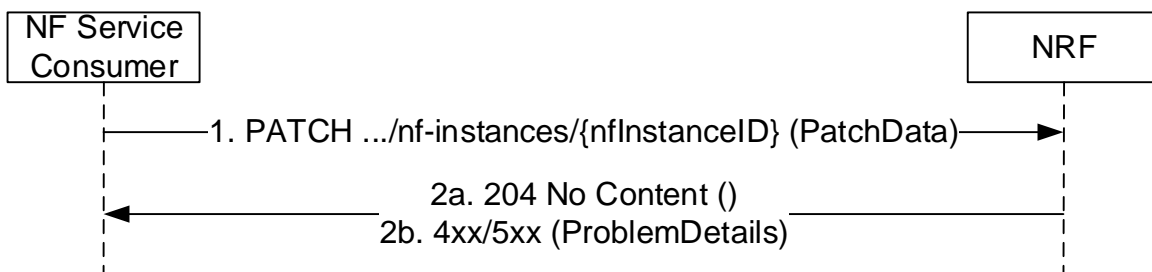

Figure 5.2.2.3.2-1: NF Heart-Beat

1. The NF Service Consumer shall send a PATCH request to the resource URI representing the NF Instance. The payload body of the PATCH request shall contain a "replace" operation on the "nfStatus" attribute of the NF Profile of the NF Instance, and set it to the value "REGISTERED".

In addition, the NF Service Consumer may also provide the load information of the NF, and/or the load information of the NF associated NF services.

2a. On success, "204 No Content" shall be returned.

2b. If the NF Instance, identified by the "nfInstanceID", is not found in the list of registered NF Instances in the NRF's database, the NRF shall return "404 Not Found" status code with the ProblemDetails IE providing details of the error.

EXAMPLE:

```
PATCH .../nf-instances/4947a69a-f61b-4bc1-b9da-47c9c5d14b64
Content-Type: application/json-patch+json
```

```
[
  { "op": "replace", "path": "/nfStatus", "value": "REGISTERED" },
  { "op": "replace", "path": "/load", "value": 50 }
]
```

```
HTTP/2 204 No Content
Content-Location: .../nf-instances/4947a69a-f61b-4bc1-b9da-47c9c5d14b64
```

5.2.2.4 NFDeregister

5.2.2.4.1 General

This service operation removes the profile of a Network Function previously registered in the NRF.

It is executed by deleting a given resource identified by a "NF Instance ID". The operation is invoked by issuing a DELETE request on the URI representing the specific NF Instance.

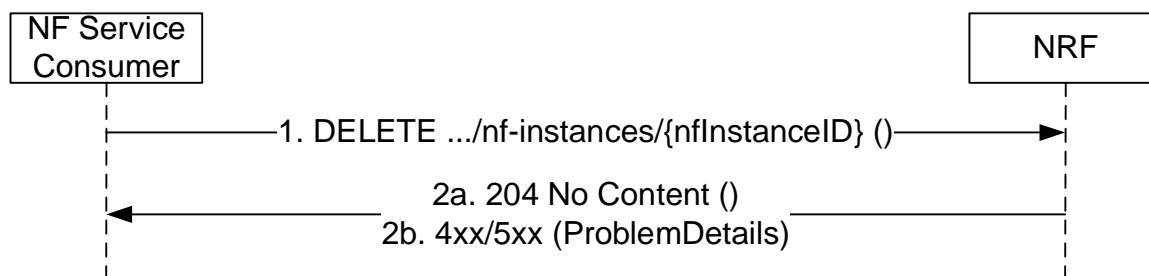

Figure 5.2.2.4.1-1: NF Instance Deregistration

1. The NF Service Consumer shall send a DELETE request to the resource URI representing the NF Instance. The request body shall be empty.

2a. On success, "204 No Content" shall be returned. The response body shall be empty.

2b. If the NF Instance, identified by the "nfInstanceID", is not found in the list of registered NF Instances in the NRF's database, the NRF shall return "404 Not Found" status code with the ProblemDetails IE providing details of the error.

5.2.2.5 NFStatusSubscribe

5.2.2.5.1 General

This service operation is used to:

- create a subscription so an NF Service Consumer can request to be notified when NF Instances of a given set, following certain filter criteria are registered/deregistered in NRF or when their profile is modified;
- create a subscription to a specific NF Instance so an NF Service Consumer can request to be notified when the profile of such NF Instance is modified or when the NF Instance is deregistered from NRF.

5.2.2.5.2 Subscription to NF Instances in the same PLMN

The subscription to notifications on NF Instances is executed creating a new individual resource under the collection resource "subscriptions". The operation is invoked by issuing a POST request on the URI representing the "subscriptions" resource.

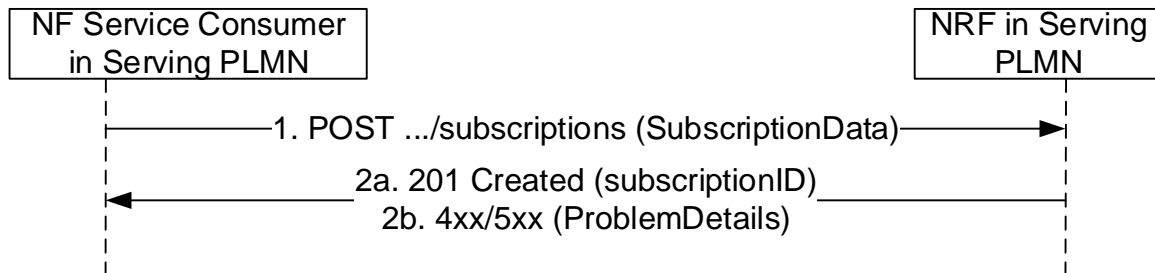

Figure 5.2.2.5.2-1: Subscription to NF Instances in the same PLMN

1. The NF Service Consumer shall send a POST request to the resource URI representing the "subscriptions" collection resource. The request body shall include the data indicating the type of notifications that the NF Service Consumer is interested in receiving; it also contains a callback URI, where the NF Service Consumer shall be prepared to receive the actual notification from the NRF (see NFStatusNotify operation in 5.2.2.6) and it may contain a validity time, suggested by the NF Service Consumer, representing the time span during which the subscription is desired to be kept active.
- 2a. On success, "201 Created" shall be returned. The response shall contain the validity time, as determined by the NRF, after which the subscription becomes invalid. Once the subscription expires, if the NF Service Consumer wants to keep receiving status notifications, it shall create a new subscription in the NRF.
- 2b. If the creation of the subscription fails at the NRF due to errors in the SubscriptionData JSON object in the request body, the NRF shall return "400 Bad Request" status code with the ProblemDetails IE providing details of the error.

If the creation of the subscription fails at the NRF due to NRF internal errors, the NRF shall return "500 Internal Server Error" status code with the ProblemDetails IE providing details of the error.

5.2.2.5.3 Subscription to NF Instances in a different PLMN

The subscription to notifications on NF Instances in a different PLMN is done by creating a resource under the collection resource "subscriptions", in the NRF of the Home PLMN.

For that, step 1 in subclause 5.2.2.5.2 is executed (send a POST request to the NRF in the Serving PLMN); this request shall include the identity of the PLMN of the home NRF in the SubscriptionData parameter in the request body.

Then, steps 1-2 in Figure 5.2.2.5.3-1 are executed, between the NRF in the Serving PLMN and the NRF in the Home PLMN. In this step, the presence of the PLMN ID in the SubscriptionData parameter is not required. The NRF in the Home PLMN returns a subscriptionID identifying the created subscription.

Finally, step 2 in subclause 5.2.2.5.2 is executed; a new subscriptionID shall be generated by the NRF in the Serving PLMN as indicated in step 2 of Figure 5.2.2.5.3-1, and shall be sent to the NF Service Consumer in the Serving PLMN.

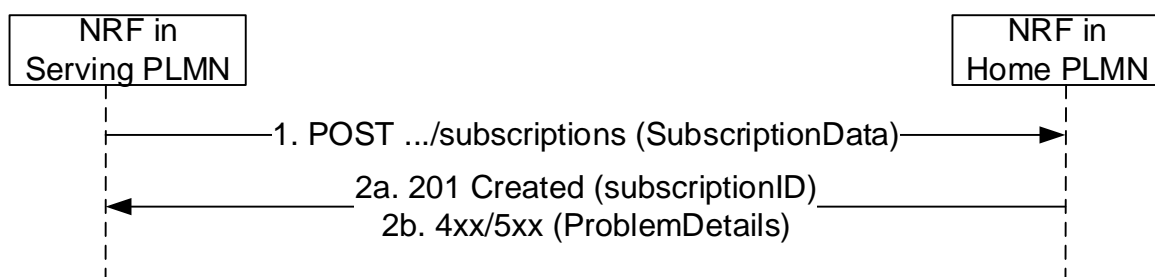

Figure 5.2.2.5.3-1: Subscription to NF Instances in a different PLMN

1. The NRF in Serving PLMN shall send a POST request to the resource URI in the NRF in Home PLMN representing the "subscriptions" collection resource. The request body shall include the SubscriptionData as received by the NRF in Serving PLMN from the NF Service Consumer in the Serving PLMN (see 5.2.2.5.2), containing the data about the type of notifications that the NF Service Consumer is interested in receiving and the callback URI where the NF Service Consumer shall be prepared to receive the notifications from the NRF (see NFStatusNotify operation in 5.2.2.6).
- 2a. On success, "201 Created" shall be returned. The NRF in Serving PLMN should not keep state for this created subscription and shall send to the NF Service Consumer in Serving PLMN (step 2 in 5.2.2.5.2) a subscriptionID that shall consist on the following structure: <MCC>+<MNC>+"-"+<OriginalSubscriptionID>

EXAMPLE: If the NRF in a Home PLMN (where MCC = 123, and MNC=456) creates a subscription with value "subs987654", the subscriptionID that the NRF in Serving PLMN would send to the NF Service Consumer in Serving PLMN is: "123456-subs987654"

- 2b. If the creation of the subscription fails at the NRF due to errors in the SubscriptionData JSON object in the request body, the NRF shall return "400 Bad Request" status code with the ProblemDetails IE providing details of the error.

If the creation of the subscription fails at the NRF due to NRF internal errors, the NRF shall return "500 Internal Server Error" status code with the ProblemDetails IE providing details of the error.

5.2.2.6 NFStatusNotify

5.2.2.6.1 General

This service operation notifies each NF Service Consumer that was previously subscribed to receiving notifications of registration/deregistration of NF Instances, or notifications of changes of the NF profile of a given NF Instance. The notification is sent to a callback URI that each NF Service Consumer provided during the subscription (see NFStatusSubscribe operation in 5.2.2.5).

5.2.2.6.2 Notification from NRF in the same PLMN

The operation is invoked by issuing a POST request to each callback URI of the different subscribed NF Instances.

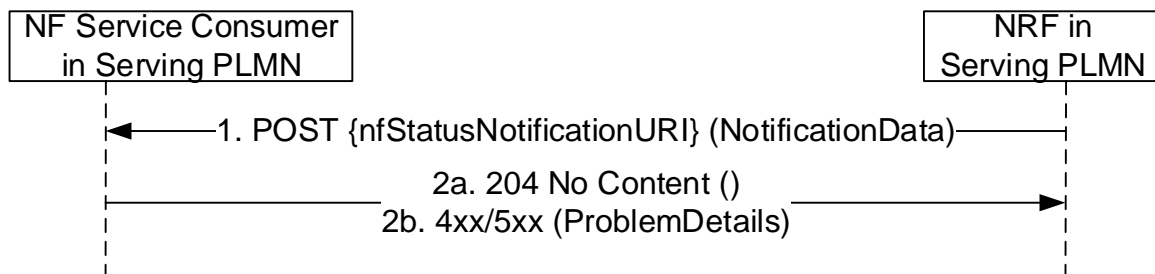

Figure 5.2.2.6.2-1: Notification from NRF in the same PLMN

1. The NRF shall send a POST request to the callback URI.

For notifications of newly registered NF Instances, the request body shall include the data associated to the newly registered NF, and its services, according to the criteria indicated by the NF Service Consumer during the subscription operation. These data shall contain the NFInstanceID of the NF Instance, an indication of the event being notified ("registration"), and the new profile data (including, among others, the services offered by the NF Instance).

For notifications of changes of the profile of a NF Instance, the request body shall include the NFInstanceID of the NF Instance whose profile was changed, an indication of the event being notified ("profile change"), and the new profile data.

For notifications of deregistration of the NF Instance from NRF, the request body shall include the NFInstanceID of the deregistered NF Instance, and an indication of the event being notified ("deregistration").

- 2a. On success, "204 No content" shall be returned by the NF Service Consumer.

- 2b. If the NF Service Consumer does not consider the "nfStatusNotificationURI" as a valid notification URI (e.g., because the URI does not belong to any of the existing subscriptions created by the NF Service Consumer in the NRF), the NF Service Consumer shall return "404 Not Found" status code with the ProblemDetails IE providing details of the error.

5.2.2.6.3 Notification from NRF in a different PLMN

The operation is invoked by issuing a POST request to each callback URI of the different subscribed NF Instances.

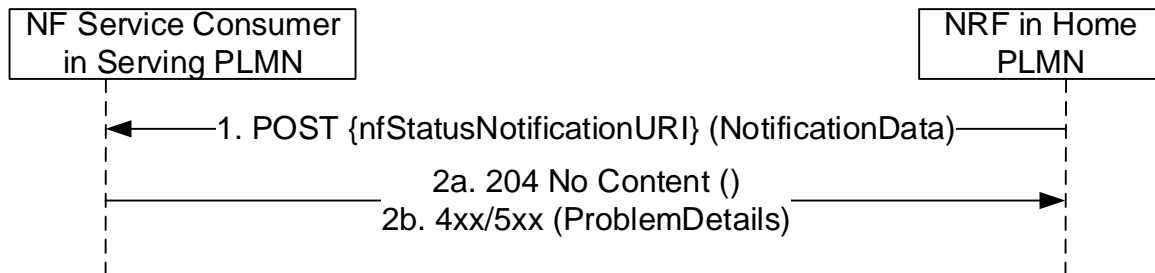

Figure 5.2.2.6.3-1: Notification from NRF in a different PLMN

Steps 1 and 2 are identical to steps 1 and 2 in Figure 5.2.2.6.2-1.

It should be noted that the POST request shall be sent directly from the NRF in Home PLMN to the NF Service Consumer in Serving PLMN, without involvement of the NRF in Serving PLMN.

5.2.2.7 NFStatusUnSubscribe

5.2.2.7.1 General

This service operation removes an existing subscription to notifications.

5.2.2.7.2 Subscription removal in the same PLMN

It is executed by deleting a given resource identified by a "subscriptionID". The operation is invoked by issuing a DELETE request on the URI representing the specific subscription.

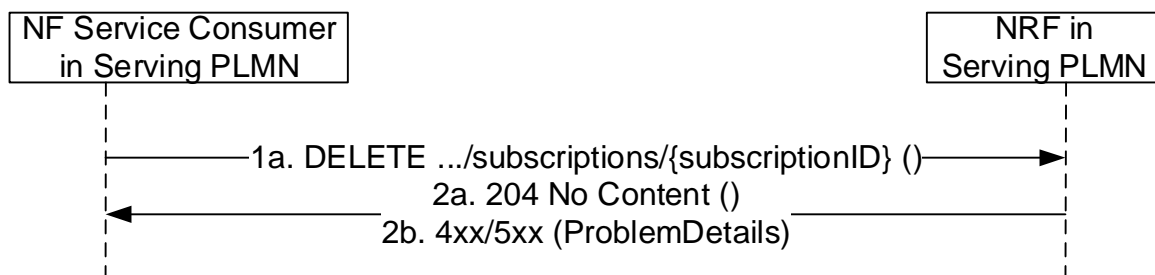

Figure 5.2.2.7.2-1: Subscription removal in the same PLMN

1. The NF Service Consumer shall send a DELETE request to the resource URI representing the individual subscription. The request body shall be empty.
- 2a. On success, "204 No Content" shall be returned. The response body shall be empty.
- 2b. If the subscription, identified by the "subscriptionID", is not found in the list of active subscriptions in the NRF's database, the NRF shall return "404 Not Found" status code with the ProblemDetails IE providing details of the error.

5.2.2.7.3 Subscription removal in a different PLMN

The subscription removal in a different PLMN is done by deleting a resource identified by a "subscriptionID", in the NRF of the Home PLMN.

For that, step 1 in subclause 5.2.2.7.2 is executed (send a DELETE request to the NRF in the Serving PLMN); this request shall include the identity of the PLMN of the home NRF (MCC/MNC values) as a leading prefix of the subscriptionID (see subclause 5.2.2.5.3).

Then, steps 1-2 in Figure 5.2.2.7.3-1 are executed, between the NRF in the Serving PLMN and the NRF in the Home PLMN. In this step, the subscriptionID sent to the NRF in the Home PLMN shall not contain the identity of the PLMN (i.e., it shall be the same subscriptionID value as originally generated by the NRF in the Home PLMN). The NRF in the Home PLMN returns a status code with the result of the operation.

Finally, step 2 in subclause 5.2.2.7.2 is executed; a status code is returned to the NF Service Consumer in Serving PLMN in accordance to the result received from NRF in Home PLMN.

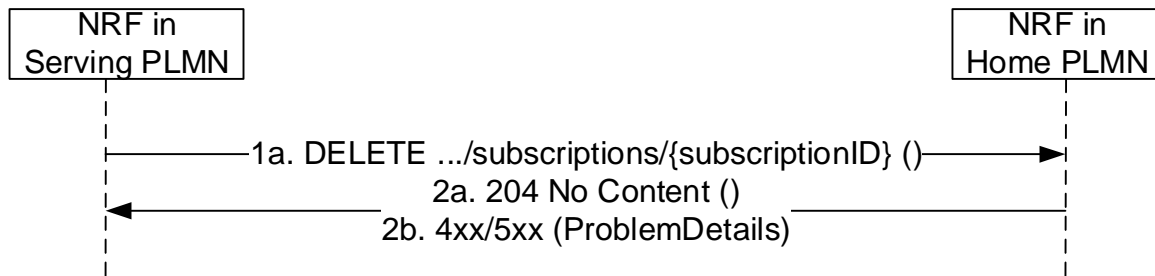

Figure 5.2.2.7.3-1: Subscription removal in a different PLMN

1. The NF Service Consumer shall send a DELETE request to the resource URI representing the individual subscription. The request body shall be empty.
- 2a. On success, "204 No Content" shall be returned. The response body shall be empty.
- 2b. If the subscription, identified by the "subscriptionID", is not found in the list of active subscriptions in the NRF's database, the NRF shall return "404 Not Found" status code with the ProblemDetails IE providing details of the error.

5.3 Nnrf_NFDiscovery Service

5.3.1 Service Description

The Nnrf_NFDiscovery service allows a Network Function Instance to discover services offered by other Network Function Instances, by querying the local NRF.

It also allows an NRF in a PLMN to re-issue a discovery request towards an NRF in another PLMN (e.g., the HPLMN of a certain UE).

5.3.2 Service Operations

5.3.2.1 Introduction

The service operations defined for the Nnrf_NFDiscovery service are as follows:

- NFDDiscover: It provides to the NF service consumer the IP address(es) or FQDN of the NF Instance(s) or NF Service(s) matching certain input criteria.

The NFDDiscover operation can be invoked by an NF Service Consumer (i.e., "source NF") requesting to discover NF instances (i.e., "target NFs") located in the same PLMN, or in a different PLMN.

In the description of these operations in subclause 5.3.2.2, when the NF instances are located in the same PLMN, both source NF and target NFs are said to be located in the "Serving PLMN" but, in the general case, the functionality is not restricted to the PLMN that is serving a given UE, and it shall be applicable as well to any scenario in which source NF and target NFs belong to the same PLMN.

When source NF and target NFs are located in different PLMNs, the source NF is said to be in the "Serving PLMN", and the target NFs (and the NRF where they are registered) are said to be in the "Home PLMN", similarly to the

scenarios described in 3GPP TS 23.502 [2], but the functionality shall be equally applicable to any scenario between any pair of PLMNs (e.g. with the source NF in the Home PLMN and the target NF in the Serving PLMN).

5.3.2.2 NFDDiscover

5.3.2.2.1 General

This service operation discovers the set of NF Instances (and their associated NF Service Instances), represented by their NF Profile, that are currently registered in NRF and satisfy a number of input query parameters.

5.3.2.2.2 Service Discovery in the same PLMN

This service operation is executed by querying the "nf-instances" resource. The request is sent to an NRF in the same PLMN of the NF Service Consumer.

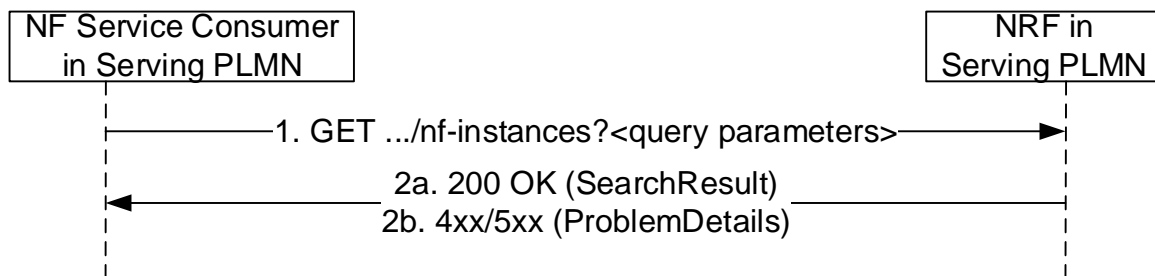

Figure 5.3.2.2.2-1: Service Discovery Request in the same PLMN

1. The NF Service Consumer shall send an HTTP GET request to the resource URI "nf-instances" collection resource. The input filter criteria for the discovery request shall be included in query parameters.
- 2a. On success, "200 OK" shall be returned. The response body shall contain a validity period, during which the search result can be cached by the NF Service Consumer, and an array of NF profile objects, that satisfy the search filter criteria (e.g., all NF Instances offering a certain NF Service name).
- 2b. If the NF Service Consumer is not allowed to discover the NF services for the requested NF type provided in the query parameters, the NRF shall return "403 Forbidden" response.

If the discovery request fails at the NRF due to errors in the input data in the URI query parameters, the NRF shall return "400 Bad Request" status code with the ProblemDetails IE providing details of the error.

If the discovery request fails at the NRF due to NRF internal errors, the NRF shall return "500 Internal Server Error" status code with the ProblemDetails IE providing details of the error.

The NF profile objects returned in a successful result shall contain generic data of each NF instance, applicable to any NF type, and it may also contain NF-specific data, for those NF instances belonging to a specific type (e.g., the attribute "udrInfo" is typically present in the NF profile when the type of the NF instance takes the value "UDR"). In addition, the attribute "customInfo", may be present in the NF profile for those NF instances with custom NF types.

For those NF instances, the "customInfo" attribute shall be returned by NRF, if available, as part of the NF profiles returned in the discovery response.

5.3.2.2.3 Service Discovery in a different PLMN

The service discovery in a different PLMN is done by querying the "nf-instances" resource in the NRF of the Home PLMN.

For that, step 1 in subclause 5.3.2.2.2 is executed (send a GET request to the NRF in the Serving PLMN); this request shall include the identity of the PLMN of the home NRF in a query parameter of the URI.

Then, steps 1-2 in Figure 5.3.2.2.3-1 are executed, between the NRF in the Serving PLMN and the NRF in the Home PLMN. In this step, the presence of the PLMN ID of the Home NRF in the query parameter of the URI is not required. The NRF in the Home PLMN returns a status code with the result of the operation.

Finally, step 2 in subclause 5.3.2.2.2 is executed; a status code is returned to the NF Service Consumer in Serving PLMN in accordance to the result received from NRF in Home PLMN.

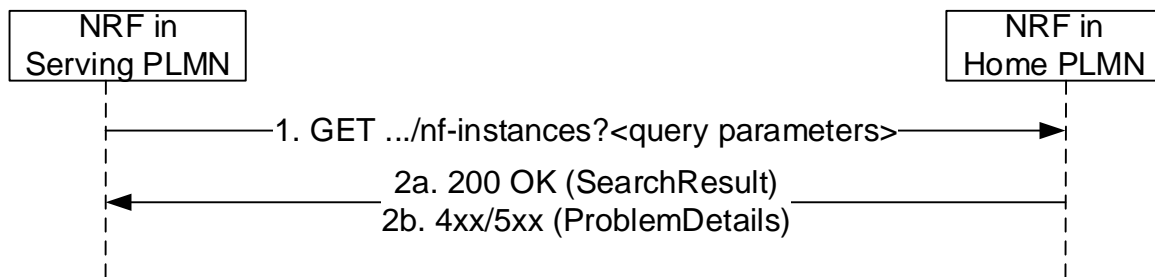

Figure 5.3.2.2.3-1: Service Discovery in a different PLMN

Steps 1 and 2 are similar to steps 1 and 2 in Figure 5.3.2.2.2-1, by replacing the originator of the service invocation with the NRF in Serving PLMN, and the recipient of the service invocation with the NRF in the Home PLMN.

5.3.2.2.4 Service Discovery with intermediate redirecting NRF

When multiple NRFs are deployed in one PLMN, one NRF may query the "nf-instances" resource in a different NRF so as to fulfil the service discovery request from a NF service consumer. The query between these two NRFs is redirected by a third NRF.

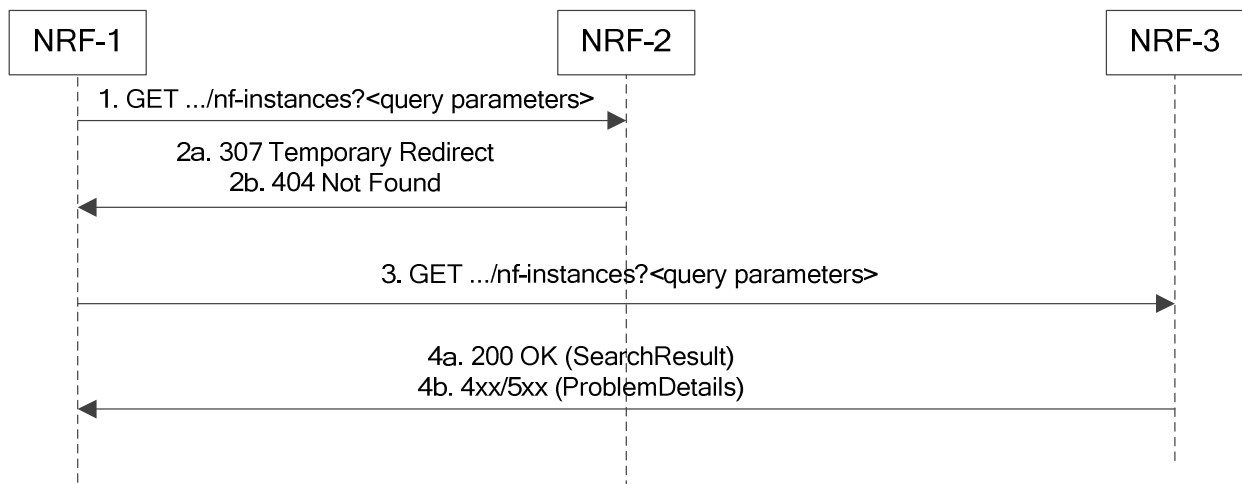

Figure 5.3.2.2.4-1: Service Discovery with intermediate redirecting NRF

1. NRF-1 receives a service discovery request but does not have the information to fulfil the request. Then NRF-1 sends the service discovery request to a pre-configured NRF-2.
- 2a. Upon receiving a service discovery request, based on the information contained in the service discovery request (e.g. the "supi" query parameter in the URI) and locally stored information NRF-2 shall identify the next hop NRF (see subclause 5.2.2.2.3), and redirect the service discovery request by returning HTTP 307 Temporary Redirect response. The locally stored information in NRF-2 may:
 - a) be preconfigured; or
 - b) registered by other NRFs (see subclause 5.2.2.2.3).

The 307 Temporary Redirect response shall contain a Location header field, the host part of the URI in the Location header field represents NRF-3.

- 2b. if NRF-2 does not have enough information to redirect the service discovery request, then it responds with 404 Not Found, and the rest of the steps are omitted.

3. Upon receiving 307 Temporary Redirect response, NRF-1 sends the service discovery request to NRF-3 by using the URI contained in the Location header field of the 307 Temporary Redirect response.

4a. Upon success, NRF-3 returns the search result.

4b. If the NF Service Consumer is not allowed to discover the NF services for the requested NF type provided in the query parameters, the NRF shall return "403 Forbidden" response.

If the discovery request fails at the NRF due to errors in the input data in the URI query parameters, the NRF shall return "400 Bad Request" status code with the ProblemDetails IE providing details of the error.

If the discovery request fails at the NRF due to NRF internal errors, the NRF shall return "500 Internal Server Error" status code with the ProblemDetails IE providing details of the error.

5.3.2.2.5 Service Discovery with intermediate forwarding NRF

When multiple NRFs are deployed in one PLMN, one NRF may query the "nf-instances" resource in a different NRF so as to fulfil the service discovery request from a NF service consumer. The query between these two NRFs is forwarded by a third NRF.

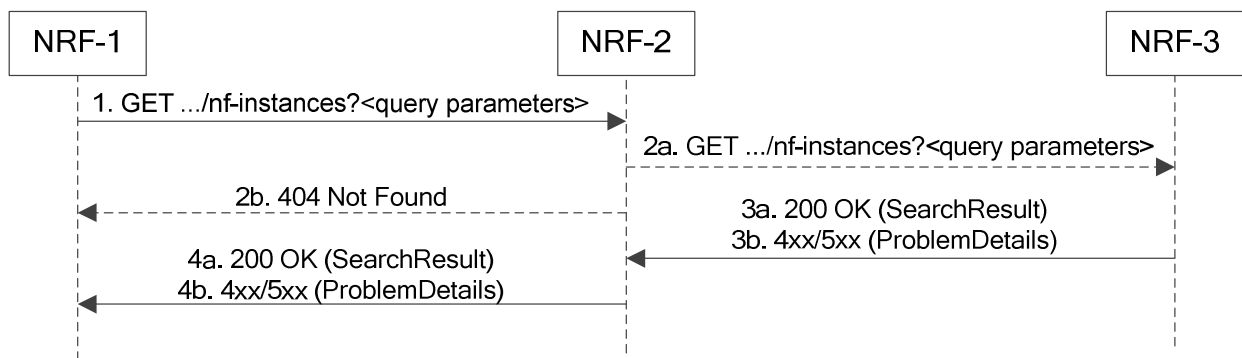

Figure 5.3.2.2.5-1: Service Discovery with intermediate forwarding NRF

1. NRF-1 receives a service discovery request but does not have the information to fulfil the request. Then NRF-1 sends the service discovery request to a pre-configured NRF-2.

2a. Upon receiving a service discovery request, based on the information contained in the service discovery request (e.g. the "supi" query parameter in the URI) and locally stored information, NRF-2 shall identify the next hop NRF (see subclause 5.2.2.2.3), and forward the service discovery request to that NRF (i.e. NRF-3 in this example), by replacing the originator of the service invocation with NRF-2, and the recipient of the service invocation with NRF-3. The locally stored information in NRF-2 may:

- a) be preconfigured; or
- b) registered by other NRFs (see subclause 5.2.2.2.3).

2b. if NRF-2 does not have enough information to forward the service discovery request, then it responds with 404 Not Found, and the rest of the steps are omitted.

3a. Upon success, NRF-3 returns the search result.

3b. If the NF Service Consumer is not allowed to discover the NF services for the requested NF type provided in the query parameters, the NRF shall return "403 Forbidden" response.

If the discovery request fails at the NRF due to errors in the input data in the URI query parameters, the NRF shall return "400 Bad Request" status code with the ProblemDetails IE providing details of the error.

If the discovery request fails at the NRF due to NRF internal errors, the NRF shall return "500 Internal Server Error" status code with the ProblemDetails IE providing details of the error.

4a. NRF-2 forwards the success response to NRF-1.

4b. NRF-2 forwards the error response to NRF-1.

NOTE: It is not assumed that there can only be two NRF hierarchies, i.e. the NRF-3 can go on to forward the service discovery request to another NRF.

5.4 OAuth2 Authorization Service

5.4.1 Service Description

The NRF offers an OAuth2 authorization service (see IETF RFC 6749 [16]), following the "Client Credentials" authorization grant, as specified in 3GPP TS 33.501 [15]. It exposes a "Token Endpoint" where the Access Token Request service can be requested by NF Service Consumers.

5.4.2 Service Operations

5.4.2.1 Introduction

The services operations defined for the OAuth2 Authorization service are as follows:

- Access Token Request

5.4.2.2 Access Token Request

5.4.2.2.1 General

This service operation is used by an NF Service Consumer to request an OAuth2 access token from the authorization server (NRF).

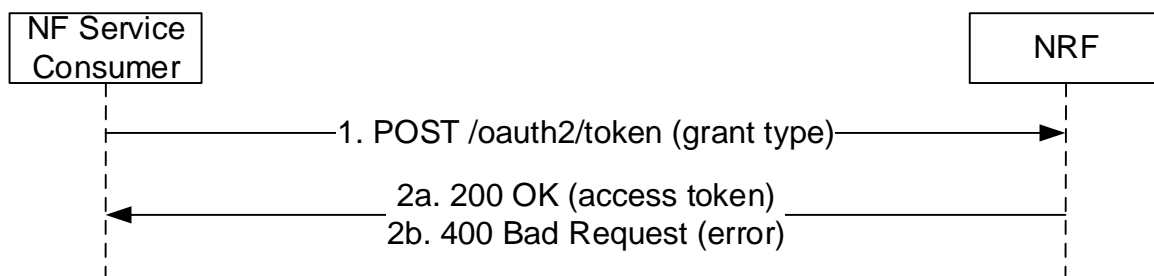

Figure 5.4.2.2.1-1: Access Token Request

1. The NF Service Consumer shall send a POST request to the "Token Endpoint", as described in IETF RFC 6749 [16], clause 3.2. The "Token Endpoint" URI shall be:

`{nrfApiRoot}/oauth2/token`

where `{nrfApiRoot}` represents the concatenation of the "scheme" and "authority" components of the NRF, as defined in IETF RFC 3986 [17].

The body of the HTTP POST request shall indicate that the required OAuth2 grant must be of type "Client Credentials". The "scope" parameter shall include the name of the NF Service that the NF Service Consumer is trying to access (i.e., the expected NF service name) and the following information shall be carried as additional parameters:

- NF Instance Id of the the NF Service Consumer requesting the OAuth2.0 access token;
- The NF type of the NF Service Producer; and
- NF Service Consumer type

Editor's Note: Whether NF instance Id of the NF service producer needs to be included in the request is FFS.

The NF Service Consumer shall use HTTP Basic authentication towards this endpoint, using the "nfInstanceId" of the NF Service Consumer as "username", and using the registered credential between NF Service Consumer and NRF, as "password".

2. On success, "200 OK" shall be returned, the payload body of the POST response shall contain, among other parameters, the requested access token, the token type and the expiration time for the token. The access token shall be a JSON Web Token (JWT) as specified in IETF RFC 7519 [25]. The access token returned by the NRF shall include the claims encoded as a JSON object as specified in subclause 6.3.5.2.4 and then digitally signed using JWS as specified in IETF RFC 7515 [24] and in subclause 13.4.1 of 3GPP TS 33.501 [15].

The digitally signed access token shall be converted to the JWS Compact Serialization encoding as a string as specified in clause 7.1 of IETF RFC 7515 [24].

If the access token request fails at the NRF, the NRF shall return "400 Bad Request" status code, including a JSON object in the response payload, that includes details about the specific error that occurred.

6 API Definitions

6.1 Nnrf_NFManagement Service API

6.1.1 API URI

URIs of this API shall have the following root:

```
{apiRoot}/{apiName}/{apiVersion}/
```

where the "apiName" shall be set to "nnrf-nfm" and the "apiVersion" shall be set to "v1" for the current version of this specification.

6.1.2 Usage of HTTP

6.1.2.1 General

HTTP/2, as defined in IETF RFC 7540 [9], shall be used as specified in clause 5 of 3GPP TS 29.500 [4].

HTTP/2 shall be transported as specified in subclause 5.3 of 3GPP TS 29.500 [4].

HTTP messages and bodies for the Nnrf_NFManagement service shall comply with the OpenAPI [10] specification contained in Annex A.

6.1.2.2 HTTP Standard Headers

6.1.2.2.1 General

6.1.2.2.2 Content type

The following content types shall be supported:

- JSON, as defined in IETF RFC 8259 [22], shall be used as content type of the HTTP bodies specified in the present specification as indicated in subclause 5.4 of 3GPP TS 29.500 [4].
- The Problem Details JSON Object (IETF RFC 7807 [11]). The use of the Problem Details JSON object in a HTTP response body shall be signalled by the content type "application/problem+json".
- JSON Patch (IETF RFC 6902 [13]). The use of the JSON Patch format in a HTTP request body shall be signalled by the content type "application/json-patch+json".
- The 3GPP hypermedia format as defined in 3GPP TS 29.501 [5]. The use of the 3GPP hypermedia format in a HTTP response body shall be signalled by the content type "application/3gppHal+json".

6.1.2.3 HTTP custom headers

6.1.2.3.1 General

In this release of this specification, no custom headers specific to the Nnrf_NFManagement service are defined. For 3GPP specific HTTP custom headers used across all service-based interfaces, see subclause 5.2.3 of 3GPP TS 29.500 [4].

6.1.3 Resources

6.1.3.1 Overview

The structure of the Resource URIs of the NFManagement service is shown in figure 6.1.3.1-1.

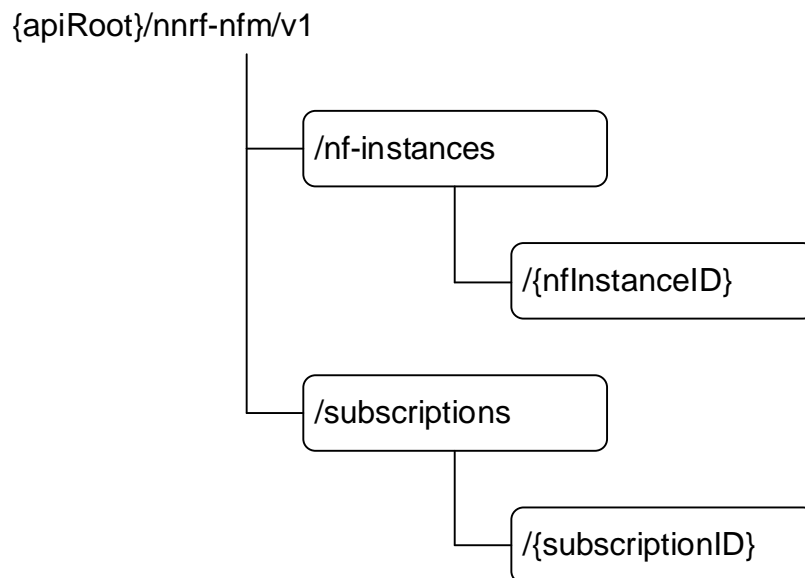

Figure 6.1.3.1-1: Resource URI structure of the NFManagement API

Table 6.1.3.1-1 provides an overview of the resources and applicable HTTP methods.

Table 6.1.3.1-1: Resources and methods overview

Resource name	Resource URI	HTTP method or custom operation	Description
nf-instances (Store)	{apiRoot}/nnrf-nfm/v1/nf-instances	GET	Read a collection of NF Instances.
nf-instance (Document)	{apiRoot}/nnrf-nfm/v1/nf-instances/{nfInstanceId}	GET	Read the profile of a given NF Instance.
		PUT	Register in NRF a new NF Instance, or replace the profile of an existing NF Instance, by providing an NF profile.
		PATCH	Modify the NF profile of an existing NF Instance.
		DELETE	Deregister from NRF a given NF Instance.
subscriptions (Collection)	{apiRoot}/nnrf-nfm/v1/subscriptions	POST	Creates a new subscription in NRF to newly registered NF Instances.
subscription (Document)	{apiRoot}/nnrf-nfm/v1/subscriptions/{subscriptionID}	DELETE	Deletes an existing subscription from NRF.
Notification Callback	{nfStatusNotificationUri}	POST	Notify about newly created NF Instances, or about changes of the profile of a given NF Instance.

6.1.3.2 Resource: nf-instances (Store)

6.1.3.2.1 Description

This resource represents a collection of the different NF instances registered in the NRF.

This resource is modelled as the Store resource archetype (see subclause C.3 of 3GPP TS 29.501 [5]).

6.1.3.2.2 Resource Definition

Resource URI: {apiRoot}/nnrf-nfm/v1/nf-instances

This resource shall support the resource URI variables defined in table 6.1.3.2.2-1.

Table 6.1.3.2.2-1: Resource URI variables for this resource

Name	Definition
apiRoot	See subclause 6.1.1

6.1.3.2.3 Resource Standard Methods

6.1.3.2.3.1 GET

This method retrieves a list of all NF instances currently registered in the NRF. This method shall support the URI query parameters specified in table 6.1.3.2.3.1-1.

Table 6.1.3.2.3.1-1: URI query parameters supported by the GET method on this resource

Name	Data type	P	Cardinality	Description
nf-type	NFType	O	0..1	The type of NF to restrict the list of returned NF Instances.
limit	integer	O	0..1	Maximum number of items to be returned in this query.

This method shall support the request data structures specified in table 6.1.3.2.3.1-2 and the response data structures and response codes specified in table 6.1.3.2.3.1-3.

Table 6.1.3.2.3.1-2: Data structures supported by the GET Request Body on this resource

Data type	P	Cardinality	Description
n/a			

Table 6.1.3.2.3.1-3: Data structures supported by the GET Response Body on this resource

Data type	P	Cardinality	Response codes	Description
UriList	M	1	200 OK	The response body contains a "_links" object containing the URI of each registered NF in the NRF, or an empty object if there are no NFs to return in the query result (e.g., because there are no registered NFs in the NRF, or because there are no matching NFs of the type specified in the "nf-type" query parameter, currently registered in the NRF).

6.1.3.2.4 Resource Custom Operations

There are no resource custom operations for the Nnrf_NFManagement service in this release of the specification.

6.1.3.3 Resource: nf-instance (Document)

6.1.3.3.1 Description

This resource represents a single NF instance.

6.1.3.3.2 Resource Definition

Resource URI: **{apiRoot}/nnrf-nfm/v1/nf-instances/{nfInstanceID}**

This resource shall support the resource URI variables defined in table 6.1.3.3.2-1.

Table 6.1.3.3.2-1: Resource URI variables for this resource

Name	Definition
apiRoot	See subclause 6.1.1
nfInstanceID	Represents a specific NF Instance

6.1.3.3.3 Resource Standard Methods

6.1.3.3.3.1 GET

This method retrieves the NF Profile of a given NF instance.

This method shall support the URI query parameters specified in table 6.1.3.3.3.1-1.

Table 6.1.3.3.3.1-1: URI query parameters supported by the GET method on this resource

Name	Data type	P	Cardinality	Description
n/a				

This method shall support the request data structures specified in table 6.1.3.3.3.1-2 and the response data structures and response codes specified in table 6.1.3.3.3.1-3.

Table 6.1.3.3.3.1-2: Data structures supported by the GET Request Body on this resource

Data type	P	Cardinality	Description
n/a			

Table 6.1.3.3.3.1-3: Data structures supported by the GET Response Body on this resource

Data type	P	Cardinality	Response codes	Description
NFProfile	M	1	200 OK	The response body contains the profile of a given NF Instance.
ProblemDetails	M	1	403 Forbidden	The NF Service Consumer is not allowed to query the instances of this NF type.

6.1.3.3.3.2 PUT

This method registers a new NF instance in the NRF, or replaces completely an existing NF instance.

This method shall support the URI query parameters specified in table 6.1.3.3.3.2-1.

Table 6.1.3.3.3.2-1: URI query parameters supported by the PUT method on this resource

Name	Data type	P	Cardinality	Description
n/a				

This method shall support the request data structures specified in table 6.1.3.3.3.2-2 and the response data structures and response codes specified in table 6.1.3.3.3.2-3.

Table 6.1.3.3.3.2-2: Data structures supported by the PUT Request Body on this resource

Data type	P	Cardinality	Description
NFProfile	M	1	Profile of the NF Instance to be registered, or completely replaced, in NRF.

Table 6.1.3.3.3.2-3: Data structures supported by the PUT Response Body on this resource

Data type	P	Cardinality	Response codes	Description
NFProfile	M	1	200 OK	This case represents the successful replacement of an existing NF Instance profile. Upon success, a response body is returned containing the replaced profile of the NF Instance.
NFRegistrationData	M	1	201 Created	This case represents the successful registration of a new NF Instance. Upon success, a response body is returned containing a heart-beat timer and the newly created NF Instance profile; also, the HTTP response shall include a "Location" HTTP header that contains the resource URI of the created NF Instance.
ProblemDetails	M	1	400 Bad Request	This case represents the failure registration of a new NF Instance, because of input parameter error.
ProblemDetails	M	1	500 Internal Server Error	This case represents the failure in the registration of a new NF Instance, because of a server internal error.

6.1.3.3.3.3 PATCH

This method updates partially the profile of a given NF instance.

This method shall support the URI query parameters specified in table 6.1.3.3.3.3-1.

Table 6.1.3.3.3.3-1: URI query parameters supported by the PATCH method on this resource

Name	Data type	P	Cardinality	Description
n/a				

This method shall support the request data structures specified in table 6.1.3.3.3.3-2 and the response data structures and response codes specified in table 6.1.3.3.3.3-3.

Table 6.1.3.3.3.3-2: Data structures supported by the PATCH Request Body on this resource

Data type	P	Cardinality	Description
PatchDocument	M	1	It contains the list of changes to be made to the profile of the NF Instance, according to the JSON PATCH format specified in IETF RFC 6902 [13].

Table 6.1.3.3.3.3-3: Data structures supported by the PATCH Response Body on this resource

Data type	P	Cardinality	Response codes	Description
NFProfile	M	1	200 OK	Upon success, a response body is returned containing the updated profile of the NF Instance.
n/a			204 No Content	Successful response sent when there is no need to provide a full updated profile of the NF Instance (e.g., in the Heart-Beat operation response described in subclause 5.2.2.3.2).

6.1.3.3.3.4 DELETE

This method deregisters an existing NF instance from the NRF.

This method shall support the URI query parameters specified in table 6.1.3.3.3.4-1.

Table 6.1.3.3.3.4-1: URI query parameters supported by the DELETE method on this resource

Name	Data type	P	Cardinality	Description
n/a				

This method shall support the request data structures specified in table 6.1.3.3.3.4-2 and the response data structures and response codes specified in table 6.1.3.3.3.4-3.

Table 6.1.3.3.3.4-2: Data structures supported by the DELETE Request Body on this resource

Data type	P	Cardinality	Description
n/a			

Table 6.1.3.3.3.4-3: Data structures supported by the DELETE Response Body on this resource

Data type	P	Cardinality	Response codes	Description
n/a			204 No Content	

6.1.3.4 Resource: subscriptions (Collection)

6.1.3.4.1 Description

This resource represents a collection of subscriptions of NF Instances to newly registered NF Instances.

6.1.3.4.2 Resource Definition

Resource URI: **{apiRoot}/nnrf-nfm/v1/subscriptions**

This resource shall support the resource URI variables defined in table 6.1.3.4.2-1.

Table 6.1.3.4.2-1: Resource URI variables for this resource

Name	Definition
apiRoot	See subclause 6.1.1

6.1.3.4.3 Resource Standard Methods

6.1.3.4.3.1 POST

This method creates a new subscription. This method shall support the URI query parameters specified in table 6.1.3.4.3.1-1.

Table 6.1.3.4.3.1-1: URI query parameters supported by the POST method on this resource

Name	Data type	P	Cardinality	Description
n/a				

This method shall support the request data structures specified in table 6.1.3.4.3.1-2 and the response data structures and response codes specified in table 6.1.3.4.3.1-3.

Table 6.1.3.4.3.1-2: Data structures supported by the POST Request Body on this resource

Data type	P	Cardinality	Description
SubscriptionData	M	1	The request body contains the input parameters for the subscription. These parameters include, e.g.: - Target NF type - Target Service Name - Callback URI of the Requester NF

Table 6.1.3.4.3.1-3: Data structures supported by the POST Response Body on this resource

Data type	P	Cardinality	Response codes	Description
SubscriptionData	M	1	201 Created	This case represents the successful creation of a subscription. Upon success, the HTTP response shall include a "Location" HTTP header that contains the resource URI of the created resource.

6.1.3.5 Resource: subscription (Document)

6.1.3.5.1 Description

This resource represents an individual subscription of a given NF Instance to newly registered NF Instances.

6.1.3.5.2 Resource Definition

Resource URI: **{apiRoot}/nnrf-nfm/v1/subscriptions/{subscriptionID}**

This resource shall support the resource URI variables defined in table 6.1.3.5.2-1.

Table 6.1.3.5.2-1: Resource URI variables for this resource

Name	Definition
apiRoot	See subclause 6.1.1
subscriptionID	Represents a specific subscription

6.1.3.5.3 Resource Standard Methods

6.1.3.5.3.1 DELETE

This method terminates an existing subscription. This method shall support the URI query parameters specified in table 6.1.3.5.3.1-1.

Table 6.1.3.5.3.1-1: URI query parameters supported by the DELETE method on this resource

Name	Data type	P	Cardinality	Description
n/a				

This method shall support the request data structures specified in table 6.1.3.5.3.1-2 and the response data structures and response codes specified in table 6.1.3.5.3.1-3.

Table 6.1.3.5.3.1-2: Data structures supported by the DELETE Request Body on this resource

Data type	P	Cardinality	Description
n/a			

Table 6.1.3.5.3.1-3: Data structures supported by the DELETE Response Body on this resource

Data type	P	Cardinality	Response codes	Description
n/a			204 No Content	

6.1.4 Custom Operations without associated resources

There are no custom operations defined without any associated resources for the Nnrf_NFManagement service in this release of the specification.

6.1.5 Notifications

6.1.5.1 General

This subclause specifies the notifications provided by the Nnrf_NFManagement service.

The delivery of notifications shall be supported as specified in subclause 6.2 of 3GPP TS 29.500 [4] for Server-initiated communication.

Table 6.1.5.1-1: Notifications overview

Notification	Resource URI	HTTP method or custom operation	Description (service operation)
NF Instance Status Notification	{nfStatusNotificationUri} (NF Service Consumer provided callback reference)	POST	Notify about registrations / deregistrations or profile changes of NF Instances

6.1.5.2 NF Instance Status Notification

6.1.5.2.1 Description

The NF Service Consumer provides a callback URI for getting notified about NF Instances status events, the NRF shall notify the NF Service Consumer, when the conditions specified in the subscription are met.

6.1.5.2.2 Notification Definition

The POST method shall be used for NF Instance Status notification and the URI shall be the callback reference provided by the NF Service Consumer during the subscription to this notification.

Resource URI: {nfStatusNotificationUri}

Support of URI query parameters is specified in table 6.1.5.2.2-1.

Table 6.1.5.2.2-1: URI query parameters supported by the POST method

Name	Data type	P	Cardinality	Description
n/a				

Support of request data structures is specified in table 6.1.5.2.2-2, and support of response data structures and response codes is specified in table 6.1.5.2-3.

Table 6.1.5.2.2-2: Data structures supported by the POST Request Body

Data type	P	Cardinality	Description
NotificationData	M	1	Representation of the NF Instance status notification.

Table 6.1.5.2.2-3: Data structures supported by the POST Response Body

Data type	P	Cardinality	Response codes	Description
N/A			204 No Content	This case represents a successful notification of the NF Instance status event.

6.1.6 Data Model

6.1.6.1 General

This subclause specifies the application data model supported by the API.

Table 6.1.6.1-1 specifies the data types defined for the Nnrf service based interface protocol.

Table 6.1.6.1-1: Nnrf_NFMManagement specific Data Types

Data type	Section defined	Description
NFProfile	6.1.6.2.2	
NFService	6.1.6.2.3	
DefaultNotificationSubscription	6.1.6.2.4	Data structure for specifying the notifications the NF service subscribes by default along with callback URI.
IpEndPoint	6.1.6.2.5	
UdrInfo	6.1.6.2.6	
UdmInfo	6.1.6.2.7	
AusfInfo	6.1.6.2.8	
SupiRange	6.1.6.2.9	
IdentityRange	6.1.6.2.10	
AmfInfo	6.1.6.2.11	
SmfInfo	6.1.6.2.12	
UpfInfo	6.1.6.2.13	Information related to UPF
SnsaiUpfInfoItem	6.1.6.2.14	
DnnUpfInfoItem	6.1.6.2.15	
SubscriptionData	6.1.6.2.16	
NotificationData	6.1.6.2.17	
NFRegistrationData	6.1.6.2.18	
NFServiceVersion	6.1.6.2.19	Contains the version details of an NF service.
PcfInfo	6.1.6.2.20	
BsfInfo	6.1.6.2.21	
Ipv4AddressRange	6.1.6.2.22	
Ipv6PrefixRange	6.1.6.2.23	
InterfaceUpfInfoItem	6.1.6.2.24	
UriList	6.1.6.2.25	
N2InterfaceAmfInfo	6.1.6.2.26	AMF N2 interface information
TaiRange	6.1.6.2.27	
TacRange	6.1.6.2.28	
Fqdn	6.1.6.3.2	
NFType	6.1.6.3.3	
NotificationType	6.1.6.3.4	
TransportProtocol	6.1.6.3.5	
NotificationEventType	6.1.6.3.6	
NFStatus	6.1.6.3.7	
DataSetId	6.1.6.3.8	
UPInterfaceType	6.1.6.3.9	
ServiceName	6.1.6.3.11	
NFServiceStatus	6.1.6.3.12	

Table 6.1.6.1-2 specifies data types re-used by the Nnrf service based interface protocol from other specifications, including a reference to their respective specifications and when needed, a short description of their use within the Nnrf service based interface.

Table 6.1.6.1-2: Nnrf_NFManagement re-used Data Types

Data type	Reference	Comments
N1MessageClass	3GPP TS 29.518 [6]	The N1 message type
N2InformationClass	3GPP TS 29.518 [6]	The N2 information type
IPv4Addr	3GPP TS 29.571 [7]	
IPv6Addr	3GPP TS 29.571 [7]	
IPv6Prefix	3GPP TS 29.571 [7]	
Uri	3GPP TS 29.571 [7]	
Dnn	3GPP TS 29.571 [7]	
SupportedFeatures	3GPP TS 29.571 [7]	
Snssai	3GPP TS 29.571 [7]	
PlmnId	3GPP TS 29.571 [7]	
Guami	3GPP TS 29.571 [7]	
Tai	3GPP TS 29.571 [7]	
NfInstanceId	3GPP TS 29.571 [7]	
LinksValueSchema	3GPP TS 29.571 [7]	3GPP Hypermedia link
UriScheme	3GPP TS 29.571 [7]	
AmfName	3GPP TS 29.571 [7]	
DateTime	3GPP TS 29.571 [7]	

6.1.6.2 Structured data types

6.1.6.2.1 Introduction

This subclause defines the structures to be used in resource representations.

6.1.6.2.2 Type: NFProfile

Table 6.1.6.2.2-1: Definition of type NFProfile

Attribute name	Data type	P	Cardinality	Description
nfInstanceID	NfInstanceID	M	1	Unique identity of the NF Instance.
nfType	NFType	M	1	Type of Network Function
nfStatus	NFStatus	M	1	Status of the NF Instance (NOTE 5)
plmn	PlmnId	O	0..1	PLMN of the Network Function
sNssais	array(Snssai)	O	0..N	S-NSSAIs of the Network Function
nsiList	array(string)	O	0..N	NSI identities of the Network Function
fqdn	Fqdn	C	0..1	FQDN of the Network Function (NOTE 1, NOTE 2). For AMF the FQDN registered with the NRF shall be that of the AMF Name (see 3GPP TS 23.003 [12] subclause 28.3.2.5).
interPlmnFqdn	Fqdn	C	0..1	If the NF needs to be discoverable by other NFs in a different PLMN, then an FQDN that is used for inter PLMN routing as specified in 3GPP TS 23.003 [12] shall be registered with the NRF.
ipv4Addresses	array(Ipv4Addr)	C	0..N	IPv4 address(es) of the Network Function (NOTE 1, NOTE 2)
ipv6Addresses	array(Ipv6Addr)	C	0..N	IPv6 address(es) of the Network Function (NOTE 1, NOTE 2)
priority	integer	O	0..1	Priority (relative to other NFs of the same type) in the range of 0-65535, to be used for NF selection; lower values indicate a higher priority. If priority is also present in the nfServiceList parameters, those will have precedence over this value. (See NOTE 4). The NRF may overwrite the received priority value when exposing an NFProfile with the Nnrf_NFDiscovery service.
capacity	integer	O	0..1	Static capacity information in the range of 0-65535, expressed as a weight relative to other NF instances of the same type; if capacity is also present in the nfServiceList parameters, those will have precedence over this value. (See NOTE 4).
load	integer	O	0..1	Dynamic load information, ranged from 0 to 100, indicates the current load percentage of the NF.
locality	string	O	0..1	Operator defined information about the location of the NF instance (e.g. geographic location, data center) (NOTE 3)
udrInfo	UdrInfo	O	0..1	Specific data for the UDR (ranges of SUPI, group ID ...)
udmInfo	UdmInfo	O	0..1	Specific data for the UDM (ranges of SUPI, group ID...)
ausfInfo	AusfInfo	O	0..1	Specific data for the AUSF (ranges of SUPI, group ID...)
amfInfo	AmfInfo	O	0..1	Specific data for the AMF (AMF Set ID, ...)
smfInfo	smfInfo	O	0..1	Specific data for the SMF (DNN's, ...)
upfInfo	UpfInfo	O	0..1	Specific data for the UPF (S-NSSAI, DNN, SMF serving area, interface...)
pcfInfo	PcfInfo	O	0..1	Specific data for the PCF
bsfInfo	BsfInfo	O	0..1	Specific data for the BSF
customInfo	object	O	0..1	Specific data for custom Network Functions
recoveryTime	DateTime	O	0..1	Timestamp when the NF was (re)started (NOTE 5, NOTE 6)
nfServices	array(NFService)	O	0..N	List of NF Service Instances
NOTE 1: At least one of the addressing parameters (fqdn, ipv4address or ipv6address) shall be included in the NF Profile.				
NOTE 2: If the type of Network Function is UPF, the addressing information is for the UPF N4 interface.				
NOTE 3: A requester NF may use this information to select a NF instance (e.g. a NF instance preferably located in the same data center).				
NOTE 4: The capacity and priority parameters, if present, are used for NF selection and load balancing. The priority and capacity attributes shall be used for NF selection in the same way that priority and weight are used for server selection as defined in IETF RFC 2782 [23].				
NOTE 5: The NRF shall notify NFs subscribed to receiving notifications of changes of the NF profile, if the NF recoveryTime or the nfStatus is changed. See subclause 6.2 of 3GPP TS 23.527 [27].				
NOTE 6: A requester NF may consider that all the resources created in the NF before the NF recovery time have been lost. This may be used to detect a restart of a NF and to trigger appropriate actions, e.g. release local resources. See subclause 6.2 of 3GPP TS 23.527 [27].				

6.1.6.2.3 Type: NFService

Table 6.1.6.2.3-1: Definition of type NFService

Attribute name	Data type	P	Cardinality	Description
serviceInstanceID	string	M	1	Unique ID of the service instance within a given NF Instance
serviceName	ServiceName	M	1	Name of the service instance (e.g. "nudm-sdm")
versions	array(NFServiceVersion)	M	1..N	The API versions supported by the NF Service and if available, the corresponding retirement date of the NF Service. The different array elements shall have distinct unique values for "apiVersionInUri", and consequently, the values of "apiFullVersion" shall have a unique first digit version number.
scheme	UriScheme	M	1	URI scheme (e.g. "http", "https")
nfServiceStatus	NFServiceStatus	M	0..1	Status of the NF Service Instance (see NOTE 3)
fqdn	Fqdn	O	0..1	FQDN of the NF where the service is hosted (see NOTE 1)
interPlmnFqdn	Fqdn	O	0..1	If the NF service needs to be discoverable by other NFs in a different PLMN, then an FQDN that is used for inter PLMN routing as specified in 3GPP TS 23.003 [12] may be registered with the NRF (see NOTE 1).
ipEndpoints	array(IpEndPoint)	O	0..N	IP address(es) and port information of the Network Function (including IPv4 and/or IPv6 address) where the service is listening for incoming service requests (see NOTE 1)
apiPrefix	string	O	0..1	Optional path segment(s) used to construct the {apiRoot} variable of the different API URIs, as described in 3GPP TS 29.501 [5], subclause 4.4.1
defaultNotificationSubscriptions	array(DefaultNotificationSubscription)	O	0..N	Notification endpoints for different notification types.
allowedPlmns	array(PlmnId)	O	0..N	PLMNs allowed to access the service instance
allowedNfTypes	array(NFType)	O	0..N	Type of the NFs allowed to access the service instance
allowedNfDomains	array(string)	O	0..N	Pattern (regular expression according to the ECMA-262 dialect [8]) representing the NF domain names allowed to access the service instance.
allowedNssais	array(Snssai)	O	0..N	S-NSSAI of the allowed slices to access the service instance
priority	integer	O	0..1	Priority (relative to other services of the same type) in the range of 0-65535, to be used for NF Service selection; lower values indicate a higher priority. (See NOTE 2). The NRF may overwrite the received priority value when exposing an NFProfile with the Nnrf_NFDiscovery service.
capacity	integer	O	0..1	Static capacity information in the range of 0-65535, expressed as a weight relative to other services of the same type. (See NOTE 2).
load	integer	O	0..1	Dynamic load information, ranged from 0 to 100, indicates the current load percentage of the NF Service.
recoveryTime	DateTime	O	0..1	Timestamp when the NF service was (re)started (NOTE 3, NOTE 4)
supportedFeatures	SupportedFeatures	O	0..1	Supported Features of the NF Service instance

NOTE 1: If the fqdn, interPlmnFqdn and ipEndpoint attributes are not present, the FQDN and IP address related attributes from the NF Profile shall be used to construct the API URIs of this service.

NOTE 2: The capacity and priority parameters, if present, are used for NF selection and load balancing. The priority and capacity attributes shall be used for NF selection in the same way that priority and weight are used for server selection as defined in IETF RFC 2782 [23].

NOTE 3: The NRF shall notify NFs subscribed to receiving notifications of changes of the NF profile, if the recoveryTime or the nfServiceStatus is changed. See subclause 6.2 of 3GPP TS 23.527 [27].

NOTE 4: A requester NF subscribed to NF status changes may consider that all the resources created in the NF service before the NF service recovery time have been lost. This may be used to detect a restart of a NF service and to trigger appropriate actions, e.g. release local resources. See subclause 6.2 of 3GPP TS 23.527 [27].

6.1.6.2.4 Type: DefaultNotificationSubscription

Table 6.1.6.2.4-1: Definition of type DefaultNotificationSubscription

Attribute name	Data type	P	Cardinality	Description
notificationType	NotificationType	M	1	Type of notification for which the corresponding callback URI is provided.
callbackUri	Uri	M	1	The callback URI.
n1MessageClass	N1MessageClass	C	0..1	If the notification type is N1_MESSAGES, this IE shall be present and shall identify the class of N1 messages to be notified.
n2InformationClass	N2InformationClass	C	0..1	If the notification type is N2_INFORMATION, this IE shall be present and shall identify the class of N2 information to be notified.

6.1.6.2.5 Type: IpEndPoint

Table 6.1.6.2.5-1: Definition of type IpEndPoint

Attribute name	Data type	P	Cardinality	Description
ipv4Address	Ipv4Addr	C	0..1	IPv4 address (NOTE 1)
ipv6Address	Ipv6Addr	C	0..1	IPv6 address (NOTE 1)
transport	TransportProtocol	O	0..1	Transport protocol
port	integer	O	0..1	Port number (NOTE 2)
NOTE 1: At most one occurrence of either ipv4Address or ipv6Address shall be included in this data structure.				
NOTE 2: If the port number is absent from the ipEndPoints attribute, the NF service consumer shall use the default HTTP port number, i.e. TCP port 80 for "http" URIs or TCP port 443 for "https" URIs as specified in IETF RFC 7540 [9] when invoking the service.				

6.1.6.2.6 Type: UdrInfo

Table 6.1.6.2.6-1: Definition of type UdrInfo

Attribute name	Data type	P	Cardinality	Description
groupId	string	O	0..1	Identity of the UDR group that is served by the UDR instance
supiRanges	array(SupiRange)	O	0..N	List of ranges of SUPI's whose profile data is available in the UDR instance (NOTE 1)
gpsiRanges	array(IdentityRange)	O	0..N	List of ranges of GPSIs whose profile data is available in the UDR instance (NOTE 1)
externalGroupIdentifiers Ranges	array(IdentityRange)	O	0..N	List of ranges of external groups whose profile data is available in the UDR instance (NOTE 1)
supportedDataSets	array(DataSetId)	O	0..N	List of supported data sets in the UDR instance
NOTE 1: If none of these parameters is provided, the UDR can serve any external group and any SUPI or GPSI.				

6.1.6.2.7 Type: UdmInfo

Table 6.1.6.2.7-1: Definition of type UdmInfo

Attribute name	Data type	P	Cardinality	Description
groupId	String	O	0..1	Identity of the UDM group that is served by the UDM instance
supiRanges	array(SupiRange)	O	0..N	List of ranges of SUPIs whose profile data is available in the UDM instance (NOTE 1)
gpsiRanges	array(IdentityRange)	O	0..N	List of ranges of GPSIs whose profile data is available in the UDM instance (NOTE 1)
externalGroupIdentifiers Ranges	array(IdentityRange)	O	0..N	List of ranges of external groups whose profile data is available in the UDM instance (NOTE 1)
routingIndicators	array(string)	O	0..N	List of Routing Indicator information that allows to route network signalling with SUCI (see 3GPP TS 23.003 [12]) to the UDM instance.
NOTE 1: If none of these parameters is provided, the UDM can serve any external group and any SUPI or GPSI.				

6.1.6.2.8 Type: AusfInfo

Table 6.1.6.2.8-1: Definition of type AusfInfo

Attribute name	Data type	P	Cardinality	Description
groupId	string	O	0..1	Identity of the AUSF group
supiRanges	array(SupiRange)	O	0..N	List of ranges of SUPIs that can be served by the AUSF instance. If not provided, the AUSF can serve any SUPI.
routingIndicators	array(string)	O	0..N	List of Routing Indicator information that allows to route network signalling with SUCI (see 3GPP TS 23.003 [12]) to the AUSF instance.

6.1.6.2.9 Type: SupiRange

Table 6.1.6.2.9-1: Definition of type SupiRange

Attribute name	Data type	P	Cardinality	Description
start	string	O	0..1	First value identifying the start of a SUPI range, to be used when the range of SUPI's can be represented as a numeric range (e.g., IMSI ranges). This string shall consist only of digits. Pattern: " $\backslash d + \$$ "
end	string	O	0..1	Last value identifying the end of a SUPI range, to be used when the range of SUPI's can be represented as a numeric range (e.g. IMSI ranges). This string shall consist only of digits. Pattern: " $\backslash d + \$$ "
pattern	string	O	0..1	Pattern (regular expression according to the ECMA-262 dialect [8]) representing the set of SUPI's belonging to this range. A SUPI value is considered part of the range if and only if the SUPI string fully matches the regular expression.

NOTE: Either the start and end attributes, or the pattern attribute, shall be present.

EXAMPLE 1: IMSI range. From: 123 45 6789040000 To: 123 45 6789059999 (i.e., 20,000 IMSI numbers)
JSON: { "start": "123456789040000", "end": "123456789059999" }

EXAMPLE 2: IMSI range. From: 123 45 6789040000 To: 123 45 6789049999 (i.e., 10,000 IMSI numbers)
JSON: { "pattern": " $\wedge \text{imsi-}12345678904 \backslash d \{4\} \$$ " }, or
JSON: { "start": "123456789040000", "end": "123456789049999" }

EXAMPLE 3: NAI range. "[smartmeter- \$\{factoryID\}\$ @company.com](#)" where " $\{factoryID\}$ " can be any string.
JSON: { "pattern": " $\wedge \text{nai-smartmeter-} . + @ \text{company} \backslash . \text{com} \$$ " }

6.1.6.2.10 Type: IdentityRange

Table 6.1.6.2.10-1: Definition of type IdentityRange

Attribute name	Data type	P	Cardinality	Description
start	string	O	0..1	First value identifying the start of an identity range, to be used when the range of identities can be represented as a numeric range (e.g., MSISDN ranges). This string shall consist only of digits. Pattern: "^d+\$"
end	string	O	0..1	Last value identifying the end of an identity range, to be used when the range of identities can be represented as a numeric range (e.g. MSISDN ranges). This string shall consist only of digits. Pattern: "^d+\$"
pattern	String	O	0..1	Pattern (regular expression according to the ECMA-262 dialect [8]) representing the set of identities belonging to this range. An identity value is considered part of the range if and only if the identity string fully matches the regular expression. To be used when identity is External Identifier or External Group Identifier or MSISDN.
NOTE: Either the start and end attributes, or the pattern attribute, shall be present.				

6.1.6.2.11 Type: AmfInfo

Table 6.1.6.2.11-1: Definition of type AmfInfo

Attribute name	Data type	P	Cardinality	Description
amfRegionId	string	M	1	AMF region identifier
amfSetId	string	M	1	AMF set identifier.
guamiList	array(Guami)	M	1..N	List of supported GUAMIs
taiList	array(Tai)	O	0..N	The list of TAIs the AMF can serve. It may contain the non-3GPP access TAI. The absence of this attribute and the taiRangeList attribute indicate that the AMF can be selected for any TAI in the serving network.
taiRangeList	array(TaiRange)	O	0..N	The range of TAIs the AMF can serve. The absence of this attribute and the taiList attribute indicate that the AMF can be selected for any TAI in the serving network.
backupInfoAmfFailure	array(Guami)	O	0..N	List of GUAMIs for which the AMF acts as a backup for AMF failure
backupInfoAmfRemoval	array(Guami)	O	0..N	List of GUAMIs for which the AMF acts as a backup for planned AMF removal
n2InterfaceAmfInfo	N2InterfaceAmfInfo	O	0..1	N2 interface information of the AMF. This information needs not be sent in NF Discovery responses. It may be used by the NRF to update the DNS for AMF discovery by the 5G Access Network. The procedures for updating the DNS are out of scope of this specification.

6.1.6.2.12 Type: SmfInfo

Table 6.1.6.2.12-1: Definition of type SmfInfo

Attribute name	Data type	P	Cardinality	Description
dnnList	array(Dnn)	M	1..N	DNNs supported by the SMF
taiList	array(Tai)	O	0..N	The list of TAIs the SMF can serve. It may contain the non-3GPP access TAI. The absence of this attribute and the taiRangeList attribute indicate that the SMF can be selected for any TAI in the serving network.
taiRangeList	array(TaiRange)	O	1..N	The range of TAIs the SMF can serve. It may contain the non-3GPP access' TAI. The absence of this attribute and the taiList attribute indicate that the SMF can be selected for any TAI in the serving network.
pgwFqdn	Fqdn	O	0..1	The FQDN of the PGW if the SMF is a combined SMF/PGW-C.

6.1.6.2.13 Type: UpfInfo

Table 6.1.6.2.13-1: Definition of type UpfInfo

Attribute name	Data type	P	Cardinality	Description
sNssaiUpfInfoList	array(SnssaiUpfInfoItem)	M	1..N	List of parameters supported by the UPF per S-NSSAI
smfServingArea	array(string)	O	0..N	The SMF service area(s) the UPF can serve
interfaceUpfInfoList	array(InterfaceUpfInfoItem)	O	0..N	List of User Plane interfaces configured on the UPF. When this IE is provided in the NF Discovery response, the NF Service Consumer (e.g SMF) may use this information for UPF selection.

6.1.6.2.14 Type: SnssaiUpfInfoItem

Table 6.1.6.2.14-1: Definition of type SnssaiUpfInfoItem

Attribute name	Data type	P	Cardinality	Description
sNssai	Snssai	M	1	Supported S-NSSAI
dnnUpfInfoList	array(DnnUpfInfoItem)	M	1..N	List of parameters supported by the UPF per DNN

6.1.6.2.15 Type: DnnUpfInfoItem

Table 6.1.6.2.15-1: Definition of type DnnUpfInfoItem

Attribute name	Data type	P	Cardinality	Description
dnn	Dnn	M	1	Supported DNN

6.1.6.2.16 Type: SubscriptionData

Table 6.1.6.2.16-1: Definition of type SubscriptionData

Attribute name	Data type	P	Cardinality	Description
nfStatusNotificationUri	Uri	M	1	Callback URI where the NF Service Consumer will receive the notifications from NRF.
subscriptionId	string	C	0..1	Subscription ID for the newly created resource. This parameter shall only be included by NRF in the response to the subscription creation request. Read-Only: true
validityTime	DateTime	C	0..1	Time instant after which the subscription becomes invalid. This parameter may be sent by the client, as a hint to the server, but it shall be always sent back by the server (regardless of the presence of the attribute in the request) in the response to the subscription creation request.
reqNotifEvents	array(Notification EventType)	O	0..N	If present, this attribute shall contain the list of event types that the NF Service Consumer is interested in receiving. If this attribute is not present, it means that notifications for all event types are requested.
nfInstanceId	NfInstanceId	C	0..1	If present, this attribute contains the NF Instance ID of a specific NF Instance, whose status is requested to be monitored. If this attribute is present, "nfType", "serviceName", "amfRegionId", "amfSetId" and "guamiList" shall be absent.
nfType	NFType	C	0..1	If present, this attribute contains the NF type of the NFs whose status is requested to be monitored. If this attribute is present, "nfInstanceId" shall be absent.
serviceName	ServiceName	C	0..1	If present, this attribute contains the service name of those NFs that offer such service, whose status is requested to be monitored. If this attribute is present, "nfInstanceId" shall be absent.
amfRegionId	string	C	0..1	If present, this attribute contains the AMF region identifier of the NFs whose status is requested to be monitored. If this attribute is present, "nfInstanceId" shall be absent.
amfSetId	string	C	0..1	If present, this attribute contains the AMF set identifier of those NFs having a certain "AMF Set ID" attribute in their profile, whose status is requested to be monitored. If this attribute is present, "nfInstanceId" shall be absent.
guamiList	array(Guami)	C	0..N	If present, this attribute contains the GUAMI(s) of the AMFs whose status is requested to be monitored. If this attribute is present, "nfInstanceId" shall be absent.
plmnId	PlmnId	O	0..1	If present, this attribute contains the target PLMN ID of the NF Instance(s) whose status is requested to be monitored.
NOTE 1: At least one of the subscription conditions (nfInstanceId, nfType, serviceName, amfRegionId, amfSetId or guamiList) shall be present in the SubscriptionData object.				
NOTE 2: If both the amfRegionId and amfSetId attributes are present in the SubscriptionData, this indicates a subscription for notifications satisfying both attributes (i.e. notifications for NFs from that amfRegionId and amfSetId).				

6.1.6.2.17 Type: NotificationData

Table 6.1.6.2.17-1: Definition of type NotificationData

Attribute name	Data type	P	Cardinality	Description
event	NotificationEventType	M	1	Notification type. It shall take the values "NF_REGISTERED", "NF_DEREGISTERED" OR "NF_PROFILE_CHANGED".
nfInstanceUri	Uri	M	1	Uri of the NF Instance (see subclause 6.1.3.3.2) associated to the notification event.
nfProfile	NFProfile	C	0..1	New NF Profile or Updated NF Profile; it shall be present when the notification type is "NF_REGISTERED" or "NF_PROFILE_CHANGED".

6.1.6.2.18 Type: NFRegistrationData

Table 6.1.6.2.18-1: Definition of type NFRegistrationData

Attribute name	Data type	P	Cardinality	Description
heartBeatTimer	integer	M	1	Time in seconds expected between 2 consecutive heart-beat messages from an NF Instance to the NRF
nfProfile	NFProfile	M	1	Profile of the registered NF Instance

6.1.6.2.19 Type: NFServiceVersion

Table 6.1.6.2.19-1: Definition of type NFServiceVersion

Attribute name	Data type	P	Cardinality	Description
apiVersionInUri	string	M	1	Version of the service instance to be used in the URI for accessing the API (e.g. "v1").
apiFullVersion	string	M	1	Full version number of the API as specified in subclause 4.3.1 of 3GPP TS 29.501 [5].
expiry	DateTime	O	0..1	Expiry date and time of the NF service. This represents the planned retirement date as specified in subclause 4.3.1.5 of 3GPP TS 29.501 [5].

6.1.6.2.20 Type: PcfInfo

Table 6.1.6.2.20-1: Definition of type PcfInfo

Attribute name	Data type	P	Cardinality	Description
dnnList	array(Dnn)	O	1..N	DNNs supported by the PCF
supiRangeList	array(SupiRange)	O	1..N	List of ranges of SUPIs that can be served by the PCF instance. If not provided, the PCF can serve any SUPI.

6.1.6.2.21 Type: BsflInfo

Table 6.1.6.2.21-1: Definition of type BsflInfo

Attribute name	Data type	P	Cardinality	Description
ipv4AddressRanges	array(Ipv4AddressRange)	O	0..N	List of ranges of IPv4 addresses handled by BSF
ipv6PrefixRanges	array(Ipv6PrefixRange)	O	0..N	List of ranges of IPv6 prefixes handled by BSF

6.1.6.2.22 Type: Ipv4AddressRange

Table 6.1.6.2.22-1: Definition of type IPv4AddressRange

Attribute name	Data type	P	Cardinality	Description
start	Ipv4Addr	M	1	First value identifying the start of an IPv4 address range
end	Ipv4Addr	M	1	Last value identifying the end of an IPv4 address range

6.1.6.2.23 Type: Ipv6PrefixRange

Table 6.1.6.2.23-1: Definition of type IPv6PrefixRange

Attribute name	Data type	P	Cardinality	Description
start	Ipv6Prefix	M	1	First value identifying the start of an IPv6 prefix range
end	Ipv6Prefix	M	1	Last value identifying the end of an IPv6 prefix range

6.1.6.2.24 Type: InterfaceUpfInfoltem

Table 6.1.6.2.24-1: Definition of type InterfaceUpfInfoltem

Attribute name	Data type	P	Cardinality	Description
interfaceType	UPInterfaceType	M	1	User Plane interface type
ipv4EndpointAddress	array(Ipv4Addr)	C	0..N	Available endpoint IPv4 address(es) of the User Plane interface (NOTE 1)
ipv6EndpointAddress	array(Ipv6Addr)	C	0..N	Available endpoint IPv6 address(es) of the User Plane interface (NOTE 1)
endpointFqdn	Fqdn	C	0..1	FQDN of available endpoint of the User Plane interface (NOTE 1)
networkInstance	string	O	0..1	Network Instance (See 3GPP TS 29.244 [21]) associated to the User Plane interface
NOTE 1: At least one of the addressing parameters (ipv4address, ipv6address or endpointFqdn) shall be included in the InterfaceUpfInfoltem.				

6.1.6.2.25 Type: UriList

Table 6.1.6.2.25-1: Definition of type UriList

Attribute name	Data type	P	Cardinality	Description
_links	map(LinksValueSchema)	O	1..N	See sub-clause 4.9.4 of 3GPP TS 29.501 [5] for the description of the members.

6.1.6.2.26 Type: N2InterfaceAmfInfo

Table 6.1.6.2.26-1: Definition of type N2InterfaceAmfInfo

Attribute name	Data type	P	Cardinality	Description
ipv4EndpointAddress	array(Ipv4Addr)	C	0..N	Available AMF endpoint IPv4 address(es) for N2 (see NOTE 1)
ipv6EndpointAddress	array(Ipv6Addr)	C	0..N	Available AMF endpoint IPv6 address(es) for N2 (see NOTE 1)
amfName	AmfName	O	0..1	AMF Name
NOTE 1: At least one of the addressing parameters (ipv4address or ipv6address) shall be included.				

6.1.6.2.27 Type: TaiRange

Table 6.1.6.2.27-1: Definition of type TaiRange

Attribute name	Data type	P	Cardinality	Description
plmnId	PlmnId	M	1	PLMN ID related to the TacRange.
tacRangeList	array(TacRange)	M	1..N	The range of the TACs

6.1.6.2.28 Type: TacRange

Table 6.1.6.2.28-1: Definition of type TacRange

Attribute name	Data type	P	Cardinality	Description
start	string	O	0..1	First value identifying the start of a TAC range, to be used when the range of TAC's can be represented as a hexadecimal range (e.g., TAC ranges). 3-octet string identifying a tracking area code, each character in the string shall take a value of "0" to "9" or "A" to "F" and shall represent 4 bits. The most significant character representing the 4 most significant bits of the TAC shall appear first in the string, and the character representing the 4 least significant bit of the TAC shall appear last in the string. Pattern: " <code>^[A-Fa-f0-9]{4}[A-Fa-f0-9]{6}\$</code> "
end	string	O	0..1	Last value identifying the end of a TAC range, to be used when the range of TAC's can be represented as a hexadecimal range (e.g. TAC ranges). 3-octet string identifying a tracking area code, each character in the string shall take a value of "0" to "9" or "A" to "F" and shall represent 4 bits. The most significant character representing the 4 most significant bits of the TAC shall appear first in the string, and the character representing the 4 least significant bit of the TAC shall appear last in the string. Pattern: " <code>^[A-Fa-f0-9]{4}[A-Fa-f0-9]{6}\$</code> "
pattern	string	O	0..1	Pattern (regular expression according to the ECMA-262 dialect [8]) representing the set of TAC's belonging to this range. A TAC value is considered part of the range if and only if the TAC string fully matches the regular expression.
NOTE: Either the start and end attributes, or the pattern attribute, shall be present.				

EXAMPLE 1: TAC range. From: 543000 To: 5433E7 (i.e., 1000 TAC numbers)
JSON: { "start": "543000", "end": "5433E7" }

EXAMPLE 2: TAC range. From: 54E000 To: 54EFFF (i.e., 4096 TAC numbers)
JSON: { "pattern": "`^tac-54E[0-9a-fA-F]{3}$`" }, or
JSON: { "start": "54E000", "end": "54EFFF" }

6.1.6.3 Simple data types and enumerations

6.1.6.3.1 Introduction

This subclause defines simple data types and enumerations that can be referenced from data structures defined in the previous subclauses.

6.1.6.3.2 Simple data types

The simple data types defined in table 6.1.6.3.2-1 shall be supported.

Table 6.1.6.3.2-1: Simple data types

Type Name	Type Definition	Description
Fqdn	string	FQDN (Fully Qualified Domain Name)

6.1.6.3.3 Enumeration: NFType

The enumeration NFType represents the different types of Network Functions that can be found in the 5GC.

Table 6.1.6.3.3-1: Enumeration NFType

Enumeration value	Description
"NRF"	Network Function: NRF
"UDM"	Network Function: UDM
"AMF"	Network Function: AMF
"SMF"	Network Function: SMF
"AUSF"	Network Function: AUSF
"NEF"	Network Function: NEF
"PCF"	Network Function: PCF
"SMSF"	Network Function: SMSF
"NSSF"	Network Function: NSSF
"UDR"	Network Function: UDR
"LMF"	Network Function: LMF
"GMLC"	Network Function: GMLC
"5G_EIR"	Network Function: 5G-EIR
"SEPP"	Network Function: SEPP
"UPF"	Network Function: UPF
"N3IWF"	Network Function: N3IWF
"AF"	Network Function: AF
"UDSF"	Network Function: UDSF
"BSF"	Network Function: BSF
"CHF"	Network Function: CHF
"NWDAF"	Network Function: NWDAF

6.1.6.3.4 Enumeration: NotificationType

Table 6.1.6.3.4-1: Enumeration NotificationType

Enumeration value	Description
"N1_MESSAGES"	Notification of N1 messages
"N2_INFORMATION"	Notification of N2 information
"LOCATION_NOTIFICATION"	Notification of Location Information by AMF towards NF Service Consumers (e.g GMLC)
"DATA_REMOVAL_NOTIFICATION"	Notification of Data Removal by UDR (e.g., removal of UE registration data upon subscription withdrawal)
"DATA_CHANGE_NOTIFICATION"	Notification of Data Changes by UDR

6.1.6.3.5 Enumeration: TransportProtocol

Table 6.1.6.3.5-1: Enumeration TransportProtocol

Enumeration value	Description
"TCP"	Transport protocol: TCP

6.1.6.3.6 Enumeration: NotificationEventType

Table 6.1.6.3.6-1: Enumeration NotificationEventType

Enumeration value	Description
"NF_REGISTERED"	The NF Instance has been registered in NRF
"NF_DEREGISTERED"	The NF Instance has been deregistered from NRF
"NF_PROFILE_CHANGED"	The profile of the NF Instance has been modified

6.1.6.3.7 Enumeration: NFStatus

Table 6.1.6.3.7-1: Enumeration NFStatus

Enumeration value	Description
"REGISTERED"	The NF Instance is registered in NRF and can be discovered by other NFs
"SUSPENDED"	The NF Instance is registered in NRF but it is not operative and cannot be discovered by other NFs

6.1.6.3.8 Enumeration: DataSetId

The enumeration DataSetId represents the different types of data sets supported by an UDR instance.

Table 6.1.6.3.8-1: Enumeration DataSetId

Enumeration value	Description
"SUBSCRIPTION"	Data set: Subscription data
"POLICY"	Data set: Policy data
"EXPOSURE"	Data set: Structured data for exposure
"APPLICATION"	Data set: Application data

6.1.6.3.9 Enumeration: UPInterfaceType

Table 6.1.6.3.9-1: Enumeration UPInterfaceType

Enumeration value	Description
"N3"	User Plane Interface: N3
"N6"	User Plane Interface: N6
"N9"	User Plane Interface: N9

6.1.6.3.10 Relation Types

6.1.6.3.10.1 General

This clause describes the possible relation types defined within NRF API. See sub-clause 4.7.5.2 of 3GPP TS 29.501 [5] for the description of the relation types.

Table 6.1.6.3.10.1-1: supported registered relation types

Relation Name
self
item

6.1.6.3.11 Enumeration: ServiceName

Table 6.1.6.3.11-1: Enumeration ServiceName

Enumeration value	Description
"nnrf-nfm"	Nnrf_NFManagement Service offered by the NRF
"nnrf-disc"	Nnrf_NFDiscovery Service offered by the NRF
"nudm-sdm"	Nudm_SubscriberDataManagement Service offered by the UDM
"nudm-uecm"	Nudm_UEContextManagement Service offered by the UDM
"nudm-ueau"	Nudm_UEAuthentication Service offered by the UDM
"nudm-ee"	Nudm_EventExposure Service offered by the UDM
"nudm-pp"	Nudm_ParameterProvision Service offered by the UDM
"namf-comm"	Namf_Communication Service offered by the AMF
"namf-evts"	Namf_EventExposure Service offered by the AMF
"namf-mt"	Namf_MT Service offered by the AMF
"namf-location"	Namf_Location Service offered by the AMF
"nsmf-pdusession"	Nsmf_PDUSession Service offered by the SMF
"nsmf-event-exposure"	Nsmf_EventExposure Service offered by the SMF
"nausf-auth"	Nausf_UEAuthentication Service offered by the AUSF
"nausf-sorprotection"	Nausf_SoRProtection Service offered by the AUSF
"nef-pfdmanagement"	Nnef_PFDManagement offered by the NEF
"npcf-am-policy-control"	Npcf_AMPolicyControl Service offered by the PCF
"npcf-smpolicycontrol"	Npcf_SMPolicyControl Service offered by the PCF
"npcf-policyauthorization"	Npcf_PolicyAuthorization Service offered by the PCF
"npcf-bdtpolicycontrol"	Npcf_BDTPolicyControl Service offered by the PCF
"nsmsf-sms"	Nsmsf_SMSService Service offered by the SMSF
"nssf-nssselection"	Nssf_NSSelection Service offered by the NSSF
"nssf-nssaiavailability"	Nssf_NSSAIAvailability Service offered by the NSSF
"nudr-dr"	Nudr_DataRepository Service offered by the UDR
"nlmf-loc"	Nlmf_Location Service offered by the LMF
"n5g-eir-eic"	N5g-eir_EquipmentIdentityCheck Service offered by the 5G-EIR
"nbsf-management"	Nbsf_Management Service offered by the BSF
"nchf-spendinglimitcontrol"	Nchf_SpendingLimitControl Service offered by the CHF
"nnwdaf-eventssubscription"	Nnwdaf_EventsSubscription Service offered by the NWDAF
"nnwdaf-analyticsinfo"	Nnwdaf_AnalyticsInfo Service offered by the NWDAF
NOTE:	The services defined in this table are those defined by 3GPP NFs in 5GC; however, in order to support custom services offered by standard and custom NFs, the NRF shall also accept the registration of NF Services with other service names.

6.1.6.3.12 Enumeration: NFServiceStatus

Table 6.1.6.3.12-1: Enumeration NFServiceStatus

Enumeration value	Description
"REGISTERED"	The NF Service Instance is registered in NRF and can be discovered by other NFs
"SUSPENDED"	The NF Service Instance is registered in NRF but it is not operative and cannot be discovered by other NFs

6.1.7 Error Handling

6.1.7.1 General

HTTP error handling shall be supported as specified in subclause 5.2.4 of 3GPP TS 29.500 [4].

6.1.7.2 Protocol Errors

Protocol errors handling shall be supported as specified in subclause 5.2.7 of 3GPP TS 29.500 [4].

6.1.7.3 Application Errors

The application errors defined for the Nnmf_NFManagement service are listed in Table 6.1.7.3-1.

Table 6.1.7.3-1: Application errors

Application Error	HTTP status code	Description

6.1.8 Security

As indicated in 3GPP TS 33.501 [15], the access to the Nnrf_NFManagement API shall be authorized by means of the OAuth2 protocol (see IETF RFC 6749 [16]), using the "Client Credentials" authorization grant, where the NRF plays the role of the authorization server.

An NF Service Consumer, prior to consuming services offered by the Nnrf_NFManagement API, shall obtain a "token" from the authorization server, by invoking the Access Token Request service, as described in subclause 5.4.2.2.

NOTE: When multiple NRFs are deployed in a network, the NRF used as authorization server is the same NRF where the Nnrf_NFManagement service is invoked by the NF Service Producer.

The Nnrf_NFManagement API does not define any scopes for OAuth2 authorization.

6.2 Nnrf_NFDiscovery Service API

6.2.1 API URI

URIs of this API shall have the following root:

```
{apiRoot}/{apiName}/{apiVersion}/
```

where the "apiName" shall be set to "nnrf-disc" and the "apiVersion" shall be set to "v1" for the current version of this specification.

6.2.2 Usage of HTTP

6.2.2.1 General

HTTP/2, as defined in IETF RFC 7540 [9], shall be used as specified in clause 5 of 3GPP TS 29.500 [4].

HTTP/2 shall be transported as specified in subclause 5.3 of 3GPP TS 29.500 [4].

HTTP messages and bodies for the Nnrf_NFDiscovery service shall comply with the OpenAPI [10] specification contained in Annex A.

6.2.2.2 HTTP Standard Headers

6.2.2.2.1 General

The mandatory standard HTTP headers as specified in subclause 5.2.2.2 of 3GPP TS 29.500 [4] shall be supported.

6.2.2.2.2 Content type

The following content types shall be supported:

- The JSON format (IETF RFC 8259 [x]). The use of the JSON format shall be signalled by the content type "application/json". See also subclause 5.4 of 3GPP TS 29.500 [4].
- The Problem Details JSON Object (IETF RFC 7807 [11]). The use of the Problem Details JSON object in a HTTP response body shall be signalled by the content type "application/problem+json".

6.2.2.2.3 Cache-Control

A "Cache-Control" header should be included in HTTP responses, as described in IETF RFC 7234 [20], section 5.2. It shall contain a "max-age" value, indicating the amount of time in seconds after which the received response is considered stale; this value shall be the same as the content of the "validityPeriod" element described in subclause 6.2.6.2.2.

6.2.2.2.4 ETag

An "ETag" (entity-tag) header should be included in HTTP responses, as described in IETF RFC 7232 [19], section 2.3. It shall contain a server-generated strong validator, that allows further matching of this value (included in subsequent client requests) with a given resource representation stored in the server or in a cache.

6.2.2.2.5 If-None-Match

An NF Service Consumer should issue conditional GET request towards NRF, by including an If-None-Match header in HTTP requests, as described in IETF RFC 7232 [19], section 3.2, containing one or several entity tags received in previous responses for the same resource.

6.2.2.3 HTTP custom headers

6.2.2.3.1 General

In this release of this specification, no custom headers specific to the Nnrf_NFDiscovery service are defined. For 3GPP specific HTTP custom headers used across all service-based interfaces, see subclause 5.2.3 of 3GPP TS 29.500 [4].

6.2.3 Resources

6.2.3.1 Overview

The structure of the Resource URIs of the NFDiscovery service is shown in figure 6.2.3.1-1.

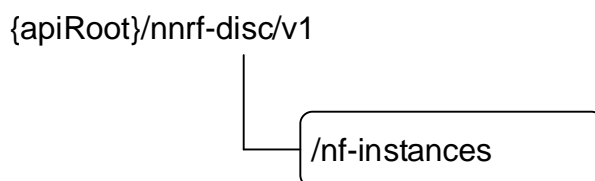

Figure 6.2.3.1-1: Resource URI structure of the NFDiscovery API

Table 6.2.3.1-1 provides an overview of the resources and applicable HTTP methods.

Table 6.2.3.1-1: Resources and methods overview

Resource name	Resource URI	HTTP method or custom operation	Description
nf-instances (Store)	{apiRoot}/nnrf-disc/v1/nf-instances	GET	Retrieve a collection of NF Instances according to certain filter criteria.

6.2.3.2 Resource: nf-instances (Store)

6.2.3.2.1 Description

This resource represents a collection of the different NF instances registered in the NRF.

This resource is modelled as the Store resource archetype (see subclause C.3 of 3GPP TS 29.501 [5]).

6.2.3.2.2 Resource Definition

Resource URI: **{apiRoot}/nnrf-disc/v1/nf-instances**

This resource shall support the resource URI variables defined in table 6.1.3.2.2-1.

Table 6.2.3.2-1: Resource URI variables for this resource

Name	Definition
apiRoot	See subclause 6.1.1

6.2.3.2.3 Resource Standard Methods

6.2.3.2.3.1 GET

This operation retrieves a list of NF Instances, and their offered services, currently registered in the NRF, satisfying a number of filter criteria, such as those NF Instances offering a certain service name, or those NF Instances of a given NF type (e.g., AMF).

Table 6.2.3.2.3.1-1: URI query parameters supported by the GET method on this resource

Name	Data type	P	Cardinality	Description
target-nf-type	NFType	M	1	This IE shall contain the NF type of the NF Service Producer being discovered.
requester-nf-type	NFType	M	1	This IE shall contain the NF type of the NF Service Consumer that is invoking the Nnrf_NFDiscovery service.
service-names	array(string)	O	1..N	If included, this IE shall contain an array of service names for which the NRF is queried to provide the list of NF profiles. The NRF shall return the NF profiles that have at least one NF service matching the NF service names in this list. The NF service names returned by the NRF shall be an intersection of the NF service names requested and the NF service names registered in the NF profile. If not included, the NRF shall return all the NF service names registered in the NF profile.
requester-nf-instance-fqdn	Fqdn	O	0..1	If included, this IE shall contain the FQDN of the NF Service Consumer that is invoking the Nnrf_NFDiscovery service. The NRF shall use this to return only those NF profiles that include at least one NF service containing an entry in the "allowedNfDomains" list (see subclause 6.1.6.2.3) that matches the domain of the requester NF.
target-plmn	PlmnId	C	0..1	This IE shall be included when NF services in a different PLMN need to be discovered. When included, this IE shall contain the PLMN ID of the different PLMN.
requester-plmn	PlmnId	C	0..1	This IE shall be included when NF services in a different PLMN need to be discovered. When included, this IE shall contain the PLMN ID of the requester NF.
target-nf-instance-id	NfInstanceId	O	0..1	Identity of the NF instance being discovered.
target-nf-fqdn	Fqdn	O	0..1	FQDN of the target NF instance being discovered.
hnrf-uri	Uri	C	0..1	If included, this IE shall contain the API URI of the NFDiscovery Service (see subclause 6.2.1) of the home NRF. It shall be included if the NF Service Consumer has previously received such API URI to be used for service discovery (e.g., from the NSSF in the home PLMN).
snssais	array(Snssai)	O	0..N	If included, this IE shall contain the list of S-NSSAI that are served by the services being discovered. The NRF shall use this to identify the NF services that have registered their support for these S-NSSAIs. The NRF shall return the NF profiles that have at least one S-NSSAI matching the S-NSSAIs in this list. The S-NSSAIs included in the NF services returned by the NRF shall be an intersection of the S-NSSAIs requested and the S-NSSAIs registered in the NF profile.
nsi-list	array(string)	O	0..N	If included, this IE shall contain the list of NSI IDs that are served by the services being discovered.
dnn	Dnn	O	0..1	If included, this IE shall contain the DNN for which NF services serving that DNN is discovered. DNN may be included if the target NF type is "SMF" or "UPF".
smf-serving-area	string	O	0..1	If included, this IE shall contain the serving area of the SMF. It may be included if the target NF type is "UPF".
tai	Tai	O	0..1	Tracking Area Identity.
amf-region-id	string	O	0..1	AMF Region Identity.
amf-set-id	string	O	0..1	AMF Set Identity.
guami	Guami	O	0..1	Guami used to search for an appropriate AMF. (NOTE 1)
supi	Supi	O	0..1	If included, this IE shall contain the SUPI of the requester UE to search for an appropriate NF. SUPI may be included if the target NF type is e.g. "PCF", "AUSF", "UDM" or "UDR".
ue-ipv4-address	Ipv4Addr	O	0..1	The IPv4 address of the UE for which a BSF needs to be discovered.

ue-ipv6-prefix	Ipv6Prefix	O	0..1	The IPv6 prefix of the UE for which a BSF needs to be discovered.
pgw-ind	boolean	O	0..1	When present, this IE indicates whether a combined SMF/PGW-C or a standalone SMF needs to be discovered. true: A combined SMF/PGW-C is requested to be discovered; false: A standalone SMF is requested to be discovered. (See NOTE 2)
pgw	Fqdn	O	0..1	If included, this IE shall contain the PGW FQDN which is received by the AMF from the MME to find the combined SMF/PGW.
gpsi	Gpsi	O	0..1	If included, this IE shall contain the GPSI of the requester UE to search for an appropriate NF. GPSI may be included if the target NF type is "UDM" or "UDR".
external-group-identity	GroupId	O	0..1	If included, this IE shall contain the external group identifier of the requester UE to search for an appropriate NF. This may be included if the target NF type is "UDM" or "UDR".
data-set	DataSetId	O	0..1	Indicates the data set to be supported by the NF to be discovered. May be included if the target NF type is "UDR".
routing-indicator	string	O	0..1	Routing Indicator information that allows to route network signalling with SUCI (see 3GPP TS 23.003 [12]) to an AUSF and UDM instance capable to serve the subscriber. May be included if the target NF type is "AUSF" or "UDM".
group-id-list	array(string)	O	1..N	Identity of the group(s) of the NFs of the target NF type to be discovered. May be included if the target NF type is "UDR", "UDM" or "AUSF".
supported-features	SupportedFeatures	O	0..1	List of features required to be supported by the target Network Function.
<p>NOTE 1: If this parameter is present and no AMF supporting the requested GUAMI is available due to AMF Failure or planned AMF removal, the NRF shall return in the response AMF instances acting as a backup for AMF failure or planned AMF removal respectively for this GUAMI. The NRF can detect if an AMF has failed, using the Heartbeat procedure. The NRF will receive a de-registration request from an AMF performing a planned removal.</p> <p>NOTE 2: If the combined SMF/PGW-C is requested to be discovered, the NRF shall return in the response the SMF instances registered with the SmfInfo containing pgwFqdn.</p>				

This method shall support the request data structures specified in table 6.1.3.2.3.1-2 and the response data structures and response codes specified in table 6.1.3.2.3.1-3.

Table 6.2.3.2.3.1-2: Data structures supported by the GET Request Body on this resource

Data type	P	Cardinality	Description
n/a			

Table 6.2.3.2.3.1-3: Data structures supported by the GET Response Body on this resource

Data type	P	Cardinality	Response codes	Description
SearchResult	M	1	200 OK	The response body contains the result of the search over the list of registered NF Instances.
n/a			307 Temporary Redirect	The response shall be used when the intermediate NRF redirects the service discovery request.
ProblemDetails	M	1	400 Bad Request	The response body contains the error reason of the request message.
ProblemDetails	M	1	403 Forbidden	This response shall be returned if the NF Service Consumer is not allowed to discover the NF Service(s) being queried.
ProblemDetails	M	1	500 Internal Server Error	The response body contains the error reason of the request message.

6.2.3.2.4 Resource Custom Operations

There are no resource custom operations for the Nnrf_NFDiscovery service in this release of the specification.

6.2.4 Custom Operations without associated resources

There are no custom operations defined without any associated resources for the Nnrf_NFDiscovery service in this release of this specification.

6.2.5 Notifications

There are no notifications defined for the Nnrf_NFDiscovery service in this release of the specification.

6.2.6 Data Model

6.2.6.1 General

This subclause specifies the application data model supported by the API.

Table 6.2.6.1-1 specifies the data types defined for the Nnrf service based interface protocol.

Table 6.2.6.1-1: Nnrf_NFDiscovery specific Data Types

Data type	Section defined	Description
SearchResult	6.2.6.2.2	
NFProfile	6.2.6.2.3	
NFService	6.2.6.2.4	

Table 6.2.6.1-2 specifies data types re-used by the Nnrf service based interface protocol from other specifications, including a reference to their respective specifications and when needed, a short description of their use within the Nnrf service based interface.

Table 6.2.6.1-2: Nnrf_NFDiscovery re-used Data Types

Data type	Reference	Comments
Snssai	3GPP TS 29.571 [7]	
PlmnId	3GPP TS 29.571 [7]	
Dnn	3GPP TS 29.571 [7]	
Tai	3GPP TS 29.571 [7]	
SupportedFeatures	3GPP TS 29.571 [7]	
NfnInstanceId	3GPP TS 29.571 [7]	
Uri	3GPP TS 29.571 [7]	
Gpsi	3GPP TS 29.571 [7]	
GroupId	3GPP TS 29.571 [7]	
Guami	3GPP TS 29.571 [7]	
IPv4Addr	3GPP TS 29.571 [7]	
IPv6Addr	3GPP TS 29.571 [7]	
UriScheme	3GPP TS 29.571 [7]	
DefaultNotificationSubscription	3GPP TS 29.510	See clause 6.1.6.2.4
IPEndPoint	3GPP TS 29.510	See clause 6.1.6.2.5
NFType	3GPP TS 29.510	See clause 6.1.6.3.3
UdrInfo	3GPP TS 29.510	See clause 6.1.6.2.6
UdmInfo	3GPP TS 29.510	See clause 6.1.6.2.7
AusfInfo	3GPP TS 29.510	See clause 6.1.6.2.8
SupiRange	3GPP TS 29.510	See clause 6.1.6.2.9
AmfInfo	3GPP TS 29.510	See clause 6.1.6.2.11
SmfInfo	3GPP TS 29.510	See clause 6.1.6.2.12
UpfInfo	3GPP TS 29.510	See clause 6.1.6.2.13
PcfInfo	3GPP TS 29.510	See clause 6.1.6.2.20
BsfInfo	3GPP TS 29.510	See clause 6.1.6.2.21
NFServiceVersion	3GPP TS 29.510	See clause 6.1.6.2.19
NFStatus	3GPP TS 29.510	See clause 6.1.6.3.7
DataSetId	3GPP TS 29.510	See clause 6.1.6.3.8
ServiceName	3GPP TS 29.510	See clause 6.1.6.3.11
NFServiceStatus	3GPP TS 29.510	See clause 6.1.6.3.12

6.2.6.2 Structured data types

6.2.6.2.1 Introduction

This subclause defines the structures to be used in resource representations.

6.2.6.2.2 Type: SearchResult

Table 6.2.6.2.2-1: Definition of type SearchResult

Attribute name	Data type	P	Cardinality	Description
validityPeriod	integer	M	1	It shall contain the time in seconds during which the discovery result is considered valid and can be cached by the NF Service Consumer. This value shall be the same as the value contained in the "max-age" parameter of the "Cache-Control" header field sent in the HTTP response.
nfnInstances	array(NFProfile)	0	0..N	If present, it shall contain an array of NF Instance profiles, matching the search criteria indicated by the query parameters of the discovery request.

6.2.6.2.3 Type: NFProfile

Table 6.2.6.2.3-1: Definition of type NFProfile

Attribute name	Data type	P	Cardinality	Description
nfInstanceId	NfInstanceId	M	1	Unique identity of the NF Instance.
nfType	NFType	M	1	Type of Network Function
nfStatus	NFStatus	M	1	Status of the NF Instance
plmn	PlmnId	O	0..1	PLMN of the Network Function
sNssais	array(Snssai)	O	0..N	S-NSSAIs of the Network Function
nsiList	array(string)	O	0..N	List of NSIs of the Network Function
fqdn	Fqdn	C	0..1	FQDN of the Network Function (NOTE 1, NOTE 3)
ipv4Addresses	array(Ipv4Addr)	C	0..N	IPv4 address(es) of the Network Function (NOTE 1)
ipv6Addresses	array(Ipv6Addr)	C	0..N	IPv6 address(es) of the Network Function (NOTE 1)
capacity	integer	O	0..1	Static capacity information in the range of 0-65535, expressed as a weight relative to other NF instances of the same type; if capacity is also present in the nfServiceList parameters, those will have precedence over this value. (See NOTE 2)
load	integer	O	0..1	Latest known load information of the NF ranged from 0 to 100 in percentage (See NOTE 4)
locality	string	O	0..1	Operator defined information about the location of the NF instance (e.g. geographic location, data center)
priority	integer	O	0..1	Priority (relative to other NFs of the same type) in the range of 0-65535, to be used for NF selection; lower values indicate a higher priority. If priority is also present in the nfServiceList parameters, those will have precedence over this value. (See NOTE 2)
udrInfo	UdrInfo	O	0..1	Specific data for the UDR (ranges of SUPI, ...)
udmInfo	UdmInfo	O	0..1	Specific data for the UDM
ausfInfo	AusfInfo	O	0..1	Specific data for the AUSF
amfInfo	AmfInfo	O	0..1	Specific data for the AMF (AMF Set ID, ...)
smfInfo	smfInfo	O	0..1	Specific data for the SMF (DNN's, ...)
upfInfo	UpfInfo	O	0..1	Specific data for the UPF (S-NSSAI, DNN, SMF serving area, ...)
pcfInfo	PcfInfo	O	0..1	Specific data for the PCF
bsfInfo	BsfInfo	O	0..1	Specific data for the BSF
customInfo	object	O	0..1	Specific data for custom Network Functions
recoveryTime	DateTime	O	0..1	Timestamp when the NF was (re)started
nfServices	array(NFService)	O	0..N	List of NF Service Instances
NOTE 1: At least one of the addressing parameters (fqdn, ipv4address or ipv6address) shall be included in the NF Profile.				
NOTE 2: The capacity and priority parameters, if present, are used for NF selection and load balancing. The priority and capacity attributes shall be used for NF selection in the same way that priority and weight are used for server selection as defined in IETF RFC 2782 [23].				
NOTE 3: If the requester-plmn in the query parameter is different from the PLMN of the discovered NF, then the fqdn attribute value shall contain the interPlmnFqdn value registered by the NF during NF registration (see subclause 6.1.6.2.2).				
NOTE 4: The usage of the load parameter by the NF service consumer is implementation specific, e.g. be used for NF selection and load balancing, together with other parameters.				

6.2.6.2.4 Type: NFService

Table 6.2.6.2.4-1: Definition of type NFService

Attribute name	Data type	P	Cardinality	Description
serviceInstanceID	string	M	1	Unique ID of the service instance within a given NF Instance
serviceName	ServiceName	M	1	Name of the service instance (e.g. "udm-sdm")
versions	array(NFServiceVersion)	M	1..N	The API versions supported by the NF Service and if available, the corresponding retirement date of the NF Service. The different array elements shall have distinct unique values for "apiVersionInUri", and consequently, the values of "apiFullVersion" shall have a unique first digit version number.
scheme	UriScheme	M	1	URI scheme (e.g. "http", "https")
nfServiceStatus	NFServiceStatus	M	0..1	Status of the NF Service Instance
fqdn	string	O	0..1	FQDN of the NF where the service is hosted (see NOTE 1, NOTE 3)
ipEndPoints	array(IpEndPoint)	O	0..N	IP address(es) and port information of the Network Function (including IPv4 and/or IPv6 address) where the service is listening for incoming service requests (see NOTE 1, NOTE 5)
apiPrefix	string	O	0..1	Optional path segment(s) used to construct the {apiRoot} variable of the different API URIs, as described in 3GPP TS 29.501 [5], subclause 4.4.1 (optional deployment-specific string that starts with a "/" character)
defaultNotificationSubscriptions	array(DefaultNotificationSubscription)	O	0..N	Notification endpoints for different notification types.
capacity	integer	O	0..1	Static capacity information in the range of 0-65535, expressed as a weight relative to other services of the same type. (See NOTE 2)
load	integer	O	0..1	Latest known load information of the NF Service, ranged from 0 to 100 in percentage. (See NOTE 4)
priority	integer	O	0..1	Priority (relative to other services of the same type) in the range of 0-65535, to be used for NF Service selection; lower values indicate a higher priority. (See NOTE 2)
recoveryTime	DateTime	O	0..1	Timestamp when the NF service was (re)started
supportedFeatures	SupportedFeatures	O	0..1	Supported Features of the NF Service instance
NOTE 1: If both the fqdn and ipEndpoints attributes are not present, the FQDN and IP address related attributes from the NF Profile shall be used to construct the API URIs of this service.				
NOTE 2: The capacity and priority parameters, if present, are used for service selection and load balancing. The priority and capacity attributes shall be used for NF selection in the same way that priority and weight are used for server selection as defined in IETF RFC 2782 [23].				
NOTE 3: If the requester-plmn in the query parameter is different from the PLMN of the discovered NF Service, then the fqdn attribute value, if included shall contain the interPlmnFqdn value registered by the NF Service during NF registration (see subclause 6.1.6.2.3).				
NOTE 4: The usage of the load parameter by the NF service consumer is implementation specific, e.g. be used for NF service selection and load balancing, together with other parameters.				
NOTE 5: If the ipEndPoints attribute is absent in the NF Service and NF Profile, the NF service consumer shall use the fqdn attribute value for DNS query and if the NF service consumer does not receive a port number during the DNS query it shall use the default HTTP port number, i.e. TCP port 80 for "http" URIs or TCP port 443 for "https" URIs as specified in IETF RFC 7540 [9] when invoking the service.				

6.2.6.3 Simple data types and enumerations

6.2.6.3.1 Introduction

This subclause defines simple data types and enumerations that can be referenced from data structures defined in the previous subclauses.

6.2.6.3.2 Simple data types

The simple data types defined in table 6.2.6.3.2-1 shall be supported.

Table 6.2.6.3.2-1: Simple data types

Type Name	Type Definition	Description

6.2.7 Error Handling

6.2.7.1 General

HTTP error handling shall be supported as specified in subclause 5.2.4 of 3GPP TS 29.500 [4].

6.2.7.2 Protocol Errors

Protocol errors handling shall be supported as specified in subclause 5.2.7 of 3GPP TS 29.500 [4].

6.2.7.3 Application Errors

The application errors defined for the Nnmf_NFDiscovery service are listed in Table 6.2.7.3-1.

Table 6.2.7.3-1: Application errors

Application Error	HTTP status code	Description

6.2.8 Security

As indicated in 3GPP TS 33.501 [15], the access to the Nnrf_NFDiscovery API shall be authorized by means of the OAuth2 protocol (see IETF RFC 6749 [16]), using the "Client Credentials" authorization grant, where the NRF plays the role of the authorization server.

An NF Service Consumer, prior to consuming services offered by the Nnrf_NFDiscovery API, shall obtain a "token" from the authorization server, by invoking the Access Token Request service, as described in subclause 5.4.2.2.

NOTE: When multiple NRFs are deployed in a network, the NRF used as authorization server is the same NRF where the Nnrf_NFDiscovery service is invoked by the NF Service Consumer.

The Nnrf_NFDiscovery API does not define any scopes for OAuth2 authorization.

6.3 OAuth2.0 Authorization Service API

6.3.1 General

This API reuses the API endpoints and input / output parameters specified in IETF RFC 6749 [16] as a custom operation without resources. Hence this clause does not follow the 3GPP specific API specification guideline specified in 3GPP TS 29.501 [5].

6.3.2 API URI

URIs of this API shall have the following root:

```
{nrfApiRoot}/oauth2/
```

where {nrfApiRoot} represents the concatenation of the "scheme" and "authority" components of the NRF, as defined in IETF RFC 3986 [17].

6.3.3 Usage of HTTP

6.3.3.1 General

HTTP/2, as defined in IETF RFC 7540 [9], shall be used as specified in clause 5 of 3GPP TS 29.500 [4].

HTTP/2 shall be transported as specified in subclause 5.3 of 3GPP TS 29.500 [4].

HTTP messages and bodies this API shall comply with the OpenAPI [10] specification contained in Annex A.

6.3.3.2 HTTP standard headers

6.3.3.2.1 General

The HTTP headers as specified in subclause 4.4 of IETF RFC 6749 [16] shall be supported. The "Authorization" header shall be supported for HTTP Basic Authentication mechanism (see subclause 5.4.2.2.1).

6.3.3.2.2 Content type

The following content types shall be supported:

- The x-www-form-urlencoded format (see subclause 17.13.4.1 of W3C HTML 4.01 Specification [26]). The use of the x-www-form-urlencoded format shall be signalled by the content type "application/x-www-form-urlencoded".
- The JSON format (IETF RFC 8259 [22]). The use of the JSON format shall be signalled by the content type "application/json". See also subclause 5.4 of 3GPP TS 29.500 [4].

6.3.3.3 HTTP custom headers

6.3.3.3.1 General

In this release of this specification, no custom headers specific to the OAuth2.0 Authorization Service API are defined. For 3GPP specific HTTP custom headers used across all service-based interfaces, see clause 5.2.3 of 3GPP TS 29.500 [4].

6.3.4 Custom Operation without Associated Resources

6.3.4.1 Overview

The /token endpoint as specified in IETF RFC 6749 [16] shall be supported. The "token endpoint" URI shall be:

{apiRoot}/token

where {apiRoot} is defined in subclause 6.3.1.

Table 6.3.4.1-1 provides an overview of the endpoints and applicable HTTP methods.

Table 6.3.4.1-1: Custom operations without associated resources

Custom operation URI	Mapped HTTP method	Description
{apiRoot}/token	POST	Access token request for obtaining OAuth2.0 access token

6.3.4.2 Operation: Access Token Request

6.3.4.2.1 Description

This custom operation represents the process for issuing the OAuth2.0 access token.

6.3.4.2.2 Operation Definition

This operation returns an OAuth 2.0 access token based on the input parameters provided. This custom operation shall use the HTTP POST method.

This method shall support the request data structures specified in table 6.3.4.2.2-1 and the response data structures and response codes specified in table 6.3.4.2.2-2. The data structure used for the POST request body shall be using x-www-urlencoded format as specified in subclause 17.13.4.1 of W3C HTML 4.01 Specification [26].

Table 6.3.4.2.2-1: Data structures supported by the POST Request Body on this endpoint

Data type	P	Cardinality	Description
AccessTokenReq	M	1	This IE shall contain the request information for the access token request.

Table 6.3.4.2.2-2: Data structures supported by the POST Response Body on this endpoint

Data type	P	Cardinality	Response codes	Description
AccessTokenRsp	M	1	200 OK	This IE shall contain the access token response information.
AccessTokenErr	M	1	400 Bad Request	See IETF RFC 6749 [16] subclause 5.2.

6.3.5 Data Model

6.3.5.1 General

This subclause specifies the application data model supported by the API.

Table 6.3.5.1-1 specifies the data types defined for the OAuth 2.0 Authorization Service API. The AccessTokenReq data structure shall be converted to the content type "application/x-www-urlencoded" when the OAuth 2.0 Access Token Request is invoked.

Table 6.3.5.1-1: OAuth 2.0 Authorization service specific Data Types

Data type	Section defined	Description
AccessTokenReq	6.3.5.2.2	Data type for carrying information related to access token request.
AccessTokenRsp	6.3.5.2.3	Data type for carrying information related to access token response.
AccessTokenClaims	6.3.5.2.4	The claims data structure for the access token.

Table 6.3.5.1-2 specifies data types re-used by the OAuth 2.0 Authorization service from other specifications, including a reference to their respective specifications and when needed, a short description of their use.

Table 6.3.5.1-2: OAuth 2.0 Authorization service re-used Data Types

Data type	Reference	Comments
NfInstanceld	3GPP TS 29.571 [7]	
NFType	3GPP TS 29.510	See subclause 6.1.6.3.3

6.3.5.2 Structured data types

6.3.5.2.1 Introduction

This subclause defines the structures to be used in the APIs.

6.3.5.2.2 Type: AccessTokenReq

Table 6.3.5.2.2-1: Definition of type AccessTokenReq

Attribute name	Data type	P	Cardinality	Description
grant_type	GrantType	M	1	This IE shall contain the grant type as "client_credentials"
nfInstanceid	NfInstanceid	M	1	This IE shall contain the NF instance id of the NF service consumer.
nfType	NFType	M	1	This IE shall contain the NF type of the NF service consumer.
targetNFtype	NFType	M	1	This IE shall contain the NF type of the NF service producer.
scope	string	M	1	This IE shall contain the NF service name of the NF service producer. The service name may include a wildcard. pattern: '^([a-zA-Z0-9_]*[0,1])\$' See NOTE 2.
NOTE 1: This data structure shall not be treated as a JSON object. It shall be treated as a key, value pair data structure to be encoded using x-www-urlencoded format as specified in subclause 17.13.4.1 of W3C HTML 4.01 Specification [26].				
NOTE 2: Though scope attribute is optional as per IETF RFC 6749 [16], it is mandatory for 3GPP as per 3GPP TS 33.501 [15].				

6.3.5.2.3 Type: AccessTokenRsp

Table 6.3.5.2.3-1: Definition of type AccessTokenRsp

Attribute name	Data type	P	Cardinality	Description
access_token	string	M	1	This IE shall contain JWS Compact Serialized representation of the JWS signed JSON object containing AccessTokenClaims (see subclause 6.3.5.2.3).
token_type	string	M	1	This IE shall contain the token type (e.g "JWT")
expires_in	string	O	0..1	This IE when present shall contain the number of seconds after which the access_token is considered to be expired.
scope	string	O	0..1	This IE when present shall contain the NF service name of the NF service producer. The service name may include a wildcard. pattern: '^([a-zA-Z0-9_]*[0,1])\$'

6.3.5.2.4 Type: AccessTokenClaims

Table 6.3.5.2.4-1: Definition of type AccessTokenClaims

Attribute name	Data type	P	Cardinality	Description
issuer	NfInstanceId	M	1	This IE shall contain NF instance id of the NF service consumer.
subject	string	M	1	This IE shall contain the NF instance ID of the NF service consumer.
audience	array(NfInstanceId)	M	1..N	This IE shall contain the NF service producer's NF instance ID (if the exact NF instance of the NF service producer is known) or a list of NF service instances of the requested NF type for which the claim is applicable.
scope	string	M	1	This IE shall contain the name of the NF services for which the access_token is authorized for use. The service name may include a wildcard. pattern: '^([a-zA-Z0-9_]*[0,1])\$'
expiration	integer	M	1	This IE shall contain the number of seconds after which the access_token is considered to be expired.

6.3.5.3 Simple data types and enumerations

6.3.5.3.1 Introduction

This subclause defines simple data types and enumerations that can be referenced from data structures defined in the previous subclauses.

6.3.5.3.2 Simple data types

There are no specific simple data types defined in this version of this API. For the re-used data types from other specifications see subclause 6.3.5.1

6.3.5.3.3 Enumeration: GrantType

Table 6.3.5.3.3-1: Enumeration GrantType

Enumeration value	Description
"client_credentials"	Represents the Client Credentials grant type.

Annex A (normative): OpenAPI specification

A.1 General

This Annex specifies the formal definition of the Nnrf Service API(s). It consists of OpenAPI 3.0.0 specifications, in YAML format.

A.2 Nnrf_NFManagement API

```

openapi: 3.0.0
info:
  version: '1.PreR15.1.0'
  title: 'NRF NFManagement Service'
  description: 'NRF NFManagement Service'
servers:
  - url: '{apiRoot}/nnrf-nfm/v1'
    variables:
      apiRoot:
        default: https://example.com
        description: apiRoot as defined in subclause subclause 4.4 of 3GPP TS 29.501
security:
  - {}
  - oAuth2ClientCredentials: []
paths:
  /nf-instances:
    get:
      summary: Retrieves a collection of NF Instances
      operationId: GetNFInstances
      tags:
        - NF Instances (Store)
      parameters:
        - name: nf-type
          in: query
          description: Type of NF
          required: false
          schema:
            $ref: '#/components/schemas/NFType'
        - name: limit
          in: query
          description: How many items to return at one time
          required: false
          schema:
            type: integer
      responses:
        '200':
          description: Expected response to a valid request
          content:
            application/3gppHal+json:
              schema:
                type: object
                properties:
                  _links:
                    type: object
                    description: 'List of the URI of NF instances. It has two members whose names
are item and self. The item one contains an array of URIs.'
                    additionalProperties:
                      $ref: 'TS29571_CommonData.yaml#/components/schemas/LinksValueSchema'
        '400':
          $ref: 'TS29571_CommonData.yaml#/components/responses/400'
        '403':
          $ref: 'TS29571_CommonData.yaml#/components/responses/403'
        '404':
          $ref: 'TS29571_CommonData.yaml#/components/responses/404'
        '411':
          $ref: 'TS29571_CommonData.yaml#/components/responses/411'
        '413':
          $ref: 'TS29571_CommonData.yaml#/components/responses/413'
        '415':
          $ref: 'TS29571_CommonData.yaml#/components/responses/415'
        '500':
          $ref: 'TS29571_CommonData.yaml#/components/responses/500'
        '501':
          $ref: 'TS29571_CommonData.yaml#/components/responses/501'
        '503':

```

```

    $ref: 'TS29571_CommonData.yaml#/components/responses/503'
  default:
    $ref: 'TS29571_CommonData.yaml#/components/responses/default'
/nf-instances/{nfInstanceID}:
  get:
    summary: Read the profile of a given NF Instance
    operationId: GetNFInstance
    tags:
      - NF Instance ID (Document)
    parameters:
      - name: nfInstanceID
        in: path
        description: Unique ID of the NF Instance
        required: true
        schema:
          $ref: 'TS29571_CommonData.yaml#/components/schemas/NfInstanceId'
    responses:
      '200':
        description: Expected response to a valid request
        content:
          application/json:
            schema:
              $ref: '#/components/schemas/NFProfile'
      '400':
        $ref: 'TS29571_CommonData.yaml#/components/responses/400'
      '403':
        $ref: 'TS29571_CommonData.yaml#/components/responses/403'
      '404':
        $ref: 'TS29571_CommonData.yaml#/components/responses/404'
      '411':
        $ref: 'TS29571_CommonData.yaml#/components/responses/411'
      '413':
        $ref: 'TS29571_CommonData.yaml#/components/responses/413'
      '415':
        $ref: 'TS29571_CommonData.yaml#/components/responses/415'
      '500':
        $ref: 'TS29571_CommonData.yaml#/components/responses/500'
      '501':
        $ref: 'TS29571_CommonData.yaml#/components/responses/501'
      '503':
        $ref: 'TS29571_CommonData.yaml#/components/responses/503'
      default:
        $ref: 'TS29571_CommonData.yaml#/components/responses/default'
  put:
    summary: Register a new NF Instance
    operationId: RegisterNFInstance
    tags:
      - NF Instance ID (Document)
    parameters:
      - name: nfInstanceID
        in: path
        required: true
        description: Unique ID of the NF Instance to register
        schema:
          $ref: 'TS29571_CommonData.yaml#/components/schemas/NfInstanceId'
    requestBody:
      content:
        application/json:
          schema:
            $ref: '#/components/schemas/NFProfile'
      required: true
    responses:
      '200':
        description: OK (Profile Replacement)
        content:
          application/json:
            schema:
              $ref: '#/components/schemas/NFProfile'
      '201':
        description: Expected response to a valid request
        content:
          application/json:
            schema:
              $ref: '#/components/schemas/NFRegistrationData'
      '400':
        $ref: 'TS29571_CommonData.yaml#/components/responses/400'
      '403':
        $ref: 'TS29571_CommonData.yaml#/components/responses/403'

```

```

'404':
  $ref: 'TS29571_CommonData.yaml#/components/responses/404'
'411':
  $ref: 'TS29571_CommonData.yaml#/components/responses/411'
'413':
  $ref: 'TS29571_CommonData.yaml#/components/responses/413'
'415':
  $ref: 'TS29571_CommonData.yaml#/components/responses/415'
'500':
  $ref: 'TS29571_CommonData.yaml#/components/responses/500'
'501':
  $ref: 'TS29571_CommonData.yaml#/components/responses/501'
'503':
  $ref: 'TS29571_CommonData.yaml#/components/responses/503'
default:
  $ref: 'TS29571_CommonData.yaml#/components/responses/default'
patch:
  summary: Update NF Instance profile
  operationId: UpdateNFInstance
  tags:
    - NF Instance ID (Document)
  parameters:
    - name: nfInstanceId
      in: path
      required: true
      description: Unique ID of the NF Instance to update
      schema:
        $ref: 'TS29571_CommonData.yaml#/components/schemas/NfInstanceId'
  requestBody:
    content:
      application/json-patch+json:
        schema:
          type: array
          items:
            $ref: 'TS29571_CommonData.yaml#/components/schemas/PatchItem'
    required: true
  responses:
    '200':
      description: Expected response to a valid request
      content:
        application/json:
          schema:
            $ref: '#/components/schemas/NFProfile'
    '204':
      description: Expected response with empty body
    '400':
      $ref: 'TS29571_CommonData.yaml#/components/responses/400'
    '403':
      $ref: 'TS29571_CommonData.yaml#/components/responses/403'
    '404':
      $ref: 'TS29571_CommonData.yaml#/components/responses/404'
    '411':
      $ref: 'TS29571_CommonData.yaml#/components/responses/411'
    '413':
      $ref: 'TS29571_CommonData.yaml#/components/responses/413'
    '415':
      $ref: 'TS29571_CommonData.yaml#/components/responses/415'
    '500':
      $ref: 'TS29571_CommonData.yaml#/components/responses/500'
    '501':
      $ref: 'TS29571_CommonData.yaml#/components/responses/501'
    '503':
      $ref: 'TS29571_CommonData.yaml#/components/responses/503'
    default:
      $ref: 'TS29571_CommonData.yaml#/components/responses/default'
delete:
  summary: Deregisters a given NF Instance
  operationId: DeregisterNFInstance
  tags:
    - NF Instance ID (Document)
  parameters:
    - name: nfInstanceId
      in: path
      required: true
      description: Unique ID of the NF Instance to deregister
      schema:
        $ref: 'TS29571_CommonData.yaml#/components/schemas/NfInstanceId'
  responses:

```

```

    '204':
      description: Expected response to a successful deregistration
/subscriptions:
  post:
    summary: Create a new subscription
    operationId: CreateSubscription
    tags:
      - Subscriptions (Collection)
    requestBody:
      content:
        application/json:
          schema:
            $ref: '#/components/schemas/SubscriptionData'
      required: true
    responses:
      '201':
        description: Expected response to a valid request
        content:
          application/json:
            schema:
              $ref: '#/components/schemas/SubscriptionData'
      '400':
        $ref: 'TS29571_CommonData.yaml#/components/responses/400'
      '403':
        $ref: 'TS29571_CommonData.yaml#/components/responses/403'
      '404':
        $ref: 'TS29571_CommonData.yaml#/components/responses/404'
      '411':
        $ref: 'TS29571_CommonData.yaml#/components/responses/411'
      '413':
        $ref: 'TS29571_CommonData.yaml#/components/responses/413'
      '415':
        $ref: 'TS29571_CommonData.yaml#/components/responses/415'
      '500':
        $ref: 'TS29571_CommonData.yaml#/components/responses/500'
      '501':
        $ref: 'TS29571_CommonData.yaml#/components/responses/501'
      '503':
        $ref: 'TS29571_CommonData.yaml#/components/responses/503'
      default:
        $ref: 'TS29571_CommonData.yaml#/components/responses/default'
  callbacks:
    onNFStatusEvent:
      '{$request.body#/nfStatusNotificationUri}':
        post:
          requestBody:
            description: Notification Payload
            content:
              application/json:
                schema:
                  $ref: '#/components/schemas/NotificationData'
          responses:
            '204':
              description: Expected response to a successful callback processing
            '400':
              $ref: 'TS29571_CommonData.yaml#/components/responses/400'
            '403':
              $ref: 'TS29571_CommonData.yaml#/components/responses/403'
            '404':
              $ref: 'TS29571_CommonData.yaml#/components/responses/404'
            '411':
              $ref: 'TS29571_CommonData.yaml#/components/responses/411'
            '413':
              $ref: 'TS29571_CommonData.yaml#/components/responses/413'
            '415':
              $ref: 'TS29571_CommonData.yaml#/components/responses/415'
            '500':
              $ref: 'TS29571_CommonData.yaml#/components/responses/500'
            '501':
              $ref: 'TS29571_CommonData.yaml#/components/responses/501'
            '503':
              $ref: 'TS29571_CommonData.yaml#/components/responses/503'
            default:
              $ref: 'TS29571_CommonData.yaml#/components/responses/default'
/subscriptions/{subscriptionID}:
  delete:
    summary: Deletes a subscription
    operationId: RemoveSubscription

```

```

tags:
  - Subscription ID (Document)
parameters:
  - name: subscriptionID
    in: path
    required: true
    description: Unique ID of the subscription to remove
    schema:
      type: string
      pattern: '^([0-9]{5,6}-)?[^-]+$'
responses:
  '204':
    description: Expected response to a successful subscription removal
  '400':
    $ref: 'TS29571_CommonData.yaml#/components/responses/400'
  '403':
    $ref: 'TS29571_CommonData.yaml#/components/responses/403'
  '404':
    $ref: 'TS29571_CommonData.yaml#/components/responses/404'
  '411':
    $ref: 'TS29571_CommonData.yaml#/components/responses/411'
  '413':
    $ref: 'TS29571_CommonData.yaml#/components/responses/413'
  '415':
    $ref: 'TS29571_CommonData.yaml#/components/responses/415'
  '500':
    $ref: 'TS29571_CommonData.yaml#/components/responses/500'
  '501':
    $ref: 'TS29571_CommonData.yaml#/components/responses/501'
  '503':
    $ref: 'TS29571_CommonData.yaml#/components/responses/503'
  default:
    $ref: 'TS29571_CommonData.yaml#/components/responses/default'
components:
  securitySchemes:
    oAuth2ClientCredentials:
      type: oauth2
      flows:
        clientCredentials:
          tokenUrl: '/oauth2/token'
          scopes: {}
schemas:
  NFProfile:
    type: object
    required:
      - nfInstanceId
      - nfType
      - nfStatus
    properties:
      nfInstanceId:
        $ref: 'TS29571_CommonData.yaml#/components/schemas/NfInstanceId'
      nfType:
        $ref: '#/components/schemas/NFType'
      nfStatus:
        $ref: '#/components/schemas/NFStatus'
      plmn:
        $ref: 'TS29571_CommonData.yaml#/components/schemas/PlmnId'
      sNssais:
        type: array
        items:
          $ref: 'TS29571_CommonData.yaml#/components/schemas/Snssai'
      nsiList:
        type: array
        items:
          type: string
      fqdn:
        $ref: '#/components/schemas/Fqdn'
      interPlmnFqdn:
        $ref: '#/components/schemas/Fqdn'
      ipv4Addresses:
        type: array
        items:
          $ref: 'TS29571_CommonData.yaml#/components/schemas/Ipv4Addr'
      ipv6Addresses:
        type: array
        items:
          $ref: 'TS29571_CommonData.yaml#/components/schemas/Ipv6Addr'
      priority:

```

```

    type: integer
    minimum: 0
    maximum: 65535
  capacity:
    type: integer
    minimum: 0
    maximum: 65535
  load:
    type: integer
    minimum: 0
    maximum: 100
  locality:
    type: string
  udrInfo:
    $ref: '#/components/schemas/UdrInfo'
  udmInfo:
    $ref: '#/components/schemas/UdmInfo'
  ausfInfo:
    $ref: '#/components/schemas/AusfInfo'
  amfInfo:
    $ref: '#/components/schemas/AmfInfo'
  smfInfo:
    $ref: '#/components/schemas/SmfInfo'
  upfInfo:
    $ref: '#/components/schemas/UpfInfo'
  pcfInfo:
    $ref: '#/components/schemas/PcfInfo'
  bsfInfo:
    $ref: '#/components/schemas/BsfInfo'
  customInfo:
    type: object
  recoveryTime:
    $ref: 'TS29571_CommonData.yaml#/components/schemas/DateTime'
  nfServices:
    type: array
    items:
      $ref: '#/components/schemas/NFService'
NFService:
  type: object
  required:
    - serviceInstanceId
    - serviceName
    - versions
    - scheme
    - nfServiceStatus
  properties:
    serviceInstanceId:
      type: string
    serviceName:
      $ref: '#/components/schemas/ServiceName'
    versions:
      type: array
      items:
        $ref: '#/components/schemas/NFServiceVersion'
    scheme:
      $ref: 'TS29571_CommonData.yaml#/components/schemas/UriScheme'
    nfServiceStatus:
      $ref: '#/components/schemas/NFServiceStatus'
    fqdn:
      $ref: '#/components/schemas/Fqdn'
    interPlmnFqdn:
      $ref: '#/components/schemas/Fqdn'
    ipEndPoints:
      type: array
      items:
        $ref: '#/components/schemas/IpEndPoint'
    apiPrefix:
      type: string
    defaultNotificationSubscriptions:
      type: array
      items:
        $ref: '#/components/schemas/DefaultNotificationSubscription'
    allowedPlmns:
      type: array
      items:
        $ref: 'TS29571_CommonData.yaml#/components/schemas/PlmnId'
    allowedNfTypes:
      type: array

```

```

    items:
      $ref: '#/components/schemas/NFType'
  allowedNfDomains:
    type: array
    items:
      type: string
  allowedNssais:
    type: array
    items:
      $ref: 'TS29571_CommonData.yaml#/components/schemas/Snssai'
  priority:
    type: integer
    minimum: 0
    maximum: 65535
  capacity:
    type: integer
    minimum: 0
    maximum: 65535
  load:
    type: integer
    minimum: 0
    maximum: 100
  recoveryTime:
    $ref: 'TS29571_CommonData.yaml#/components/schemas/DateTime'
  supportedFeatures:
    $ref: 'TS29571_CommonData.yaml#/components/schemas/SupportedFeatures'
NFType:
  anyOf:
    - type: string
      enum:
        - NRF
        - UDM
        - AMF
        - SMF
        - AUSF
        - NEF
        - PCF
        - SMSF
        - NSSF
        - UDR
        - LMF
        - GMLC
        - 5G_EIR
        - SEPP
        - UPF
        - N3IWF
        - AF
        - UDSF
        - BSF
        - CHF
        - NWDAF
    - type: string
Fqdn:
  type: string
IpEndPoint:
  type: object
  properties:
    ipv4Address:
      $ref: 'TS29571_CommonData.yaml#/components/schemas/Ipv4Addr'
    ipv6Address:
      $ref: 'TS29571_CommonData.yaml#/components/schemas/Ipv6Addr'
    transport:
      $ref: '#/components/schemas/TransportProtocol'
    port:
      type: integer
SubscriptionData:
  type: object
  required:
    - nfStatusNotificationUri
    - subscriptionId
  properties:
    nfStatusNotificationUri:
      type: string
    subscriptionId:
      type: string
      pattern: '^([0-9]{5,6}-)?[^-]+$'
      readOnly: true
    validityTime:

```

```

    $ref: 'TS29571_CommonData.yaml#/components/schemas/DateTime'
  reqNotifEvents:
    type: array
    items:
      $ref: '#/components/schemas/NotificationEventType'
  plmnId:
    $ref: 'TS29571_CommonData.yaml#/components/schemas/PlmnId'
  nfInstanceId:
    $ref: 'TS29571_CommonData.yaml#/components/schemas/NfInstanceId'
  nfType:
    $ref: '#/components/schemas/NFType'
  serviceName:
    type: $ref: '#/components/schemas/ServiceName'
  amfSetId:
    type: string
  amfRegionId:
    type: string
  guamiList:
    type: array
    items:
      $ref: 'TS29571_CommonData.yaml#/components/schemas/Guami'
UdrInfo:
  type: object
  properties:
    groupId:
      type: string
    supiRanges:
      type: array
      items:
        $ref: '#/components/schemas/SupiRange'
    gpsiRanges:
      type: array
      items:
        $ref: '#/components/schemas/IdentityRange'
    externalGroupIdentityifiersRanges:
      type: array
      items:
        $ref: '#/components/schemas/IdentityRange'
    supportedDataSets:
      type: array
      items:
        $ref: '#/components/schemas/DataSetId'
SupiRange:
  type: object
  properties:
    start:
      type: string
    end:
      type: string
    pattern:
      type: string
IdentityRange:
  type: object
  properties:
    start:
      type: string
    end:
      type: string
    pattern:
      type: string
DataSetId:
  anyOf:
    - type: string
      enum:
        - SUBSCRIPTION
        - POLICY
        - EXPOSURE
        - APPLICATION
    - type: string
UdmInfo:
  type: object
  properties:
    groupId:
      type: string
    supiRanges:
      type: array
      items:
        $ref: '#/components/schemas/SupiRange'

```



```

    gpsIRanges:
      type: array
      items:
        $ref: '#/components/schemas/IdentityRange'
    externalGroupIdentityifiersRanges:
      type: array
      items:
        $ref: '#/components/schemas/IdentityRange'
    routingIndicators:
      type: array
      items:
        type: string
  AusfInfo:
    type: object
    properties:
      groupId:
        type: string
      supIRanges:
        type: array
        items:
          $ref: '#/components/schemas/SupiRange'
      routingIndicators:
        type: array
        items:
          type: string
  AmfInfo:
    type: object
    required:
      - amfSetId
      - amfRegionId
      - guamiList
    properties:
      amfSetId:
        type: string
      amfRegionId:
        type: string
      guamiList:
        type: array
        items:
          $ref: 'TS29571_CommonData.yaml#/components/schemas/Guami'
      taiList:
        type: array
        items:
          $ref: 'TS29571_CommonData.yaml#/components/schemas/Tai'
      taiRangeList:
        type: array
        items:
          $ref: '#/components/schemas/TaiRange'
      backupInfoAmfFailure:
        type: array
        items:
          $ref: 'TS29571_CommonData.yaml#/components/schemas/Guami'
      backupInfoAmfRemoval:
        type: array
        items:
          $ref: 'TS29571_CommonData.yaml#/components/schemas/Guami'
      n2InterfaceAmfInfo:
        $ref: '#/components/schemas/N2InterfaceAmfInfo'
  SmfInfo:
    type: object
    required:
      - dnnList
    properties:
      dnnList:
        type: array
        items:
          $ref: 'TS29571_CommonData.yaml#/components/schemas/Dnn'
      taiList:
        type: array
        items:
          $ref: 'TS29571_CommonData.yaml#/components/schemas/Tai'
      taiRangeList:
        type: array
        items:
          $ref: '#/components/schemas/TaiRange'
      pgwFqdn:
        $ref: '#/components/schemas/Fqdn'
  UpfInfo:

```

```

type: object
required:
  - sNssaiUpfInfoList
properties:
  sNssaiUpfInfoList:
    type: array
    items:
      $ref: '#/components/schemas/SnssaiUpfInfoItem'
    minItems: 1
  smfServingArea:
    type: array
    items:
      type: string
  interfaceUpfInfoList:
    type: array
    items:
      $ref: '#/components/schemas/InterfaceUpfInfoItem'
SnssaiUpfInfoItem:
type: object
required:
  - sNssai
  - dnnUpfInfoList
properties:
  sNssai:
    $ref: 'TS29571_CommonData.yaml#/components/schemas/Snssai'
  dnnUpfInfoList:
    type: array
    items:
      $ref: '#/components/schemas/DnnUpfInfoItem'
    minItems: 1
DnnUpfInfoItem:
type: object
required:
  - dnn
properties:
  dnn:
    $ref: 'TS29571_CommonData.yaml#/components/schemas/Dnn'
InterfaceUpfInfoItem:
type: object
required:
  - interfaceType
properties:
  interfaceType:
    $ref: '#/components/schemas/UPInterfaceType'
  ipv4EndpointAddress:
    type: array
    items:
      $ref: 'TS29571_CommonData.yaml#/components/schemas/Ipv4Addr'
  ipv6EndpointAddress:
    type: array
    items:
      $ref: 'TS29571_CommonData.yaml#/components/schemas/Ipv6Addr'
  endpointFqdn:
    $ref: '#/components/schemas/Fqdn'
  networkInstance:
    type: string
UPInterfaceType:
anyOf:
  - type: string
    enum:
      - N3
      - N6
      - N9
  - type: string
PcfInfo:
type: object
properties:
  dnnList:
    type: array
    items:
      $ref: 'TS29571_CommonData.yaml#/components/schemas/Dnn'
  supiRangeList:
    type: array
    items:
      $ref: '#/components/schemas/SupiRange'
BsfInfo:
type: object
properties:

```

```

    ipv4AddressRanges:
      type: array
      items:
        $ref: '#/components/schemas/Ipv4AddressRange'
    ipv6PrefixRanges:
      type: array
      items:
        $ref: '#/components/schemas/Ipv6PrefixRange'
  Ipv4AddressRange:
    type: object
    properties:
      start:
        $ref: 'TS29571_CommonData.yaml#/components/schemas/Ipv4Addr'
      end:
        $ref: 'TS29571_CommonData.yaml#/components/schemas/Ipv4Addr'
  Ipv6PrefixRange:
    type: object
    properties:
      start:
        $ref: 'TS29571_CommonData.yaml#/components/schemas/Ipv6Prefix'
      end:
        $ref: 'TS29571_CommonData.yaml#/components/schemas/Ipv6Prefix'
  DefaultNotificationSubscription:
    type: object
    required:
      - notificationType
      - callbackUri
    properties:
      notificationType:
        $ref: '#/components/schemas/NotificationType'
      callbackUri:
        $ref: 'TS29571_CommonData.yaml#/components/schemas/Uri'
      n1MessageClass:
        $ref: 'TS29518_Namf_Communication.yaml#/components/schemas/N1MessageClass'
      n2InformationClass:
        $ref: 'TS29518_Namf_Communication.yaml#/components/schemas/N2InformationClass'
  NotificationType:
    anyOf:
      - type: string
        enum:
          - N1_MESSAGES
          - N2_INFORMATION
          - LOCATION_NOTIFICATION
          - DATA_REMOVAL_NOTIFICATION
          - DATA_CHANGE_NOTIFICATION
      - type: string
  TransportProtocol:
    anyOf:
      - type: string
        enum:
          - TCP
      - type: string
  NotificationEventType:
    anyOf:
      - type: string
        enum:
          - NF_REGISTERED
          - NF_DEREGISTERED
          - NF_PROFILE_CHANGED
      - type: string
  NotificationData:
    type: object
    required:
      - event
      - nfInstanceUri
    properties:
      event:
        $ref: '#/components/schemas/NotificationEventType'
      nfInstanceUri:
        $ref: 'TS29571_CommonData.yaml#/components/schemas/Uri'
      newProfile:
        $ref: '#/components/schemas/NFProfile'
  NFStatus:
    anyOf:
      - type: string
        enum:
          - REGISTERED
          - SUSPENDED

```

```

    - type: string
NFRegistrationData:
  type: object
  required:
    - heartBeatTimer
    - nfProfile
  properties:
    heartBeatTimer:
      type: integer
    nfProfile:
      $ref: '#/components/schemas/NFProfile'
NFServiceVersion:
  type: object
  required:
    - apiVersionInUri
    - apiFullVersion
  properties:
    apiVersionInUri:
      type: string
    apiFullVersion:
      type: string
    expiry:
      $ref: 'TS29571_CommonData.yaml#/components/schemas/DateTime'
ServiceName:
  anyOf:
    - type: string
      enum:
        - nrf-nfm
        - nrf-disc
        - nudm-sdm
        - nudm-uecm
        - nudm-ueau
        - nudm-ee
        - nudm-pp
        - namf-comm
        - namf-evts
        - namf-mt
        - namf-location
        - nsmf-pdusection
        - nsmf-event-exposure
        - nausf-auth
        - nausf-sorprotection
        - nef-pfdmanagement
        - npcf-am-policy-control
        - npcf-smpolicycontrol
        - npcf-policyauthorization
        - npcf-bdtpolicycontrol
        - nsmsf-sms
        - nssf-nssselection
        - nssf-nssaiavailability
        - nudr-dr
        - nlmf-loc
        - n5g-eir-eic
        - nbsf-management
        - nchf-spendinglimitcontrol
        - nnwaf-eventsubscription
        - nnwaf-analyticsinfo
    - type: string
N2InterfaceAmfInfo:
  type: object
  properties:
    ipv4EndpointAddress:
      type: array
      items:
        $ref: 'TS29571_CommonData.yaml#/components/schemas/Ipv4Addr'
    ipv6EndpointAddress:
      type: array
      items:
        $ref: 'TS29571_CommonData.yaml#/components/schemas/Ipv6Addr'
    amfName:
      $ref: 'TS29571_CommonData.yaml#/components/schemas/AmfName'
NFServiceStatus:
  anyOf:
    - type: string
      enum:
        - REGISTERED
        - SUSPENDED
    - type: string

```

```

TaiRange:
  type: object
  required:
    - plmnId
  properties:
    plmnId:
      $ref: 'TS29571_CommonData.yaml#/components/schemas/PlmnId'
    tacRangeList:
      type: array
      items:
        $ref: '#/components/schemas/TacRange'
TacRange:
  type: object
  properties:
    start:
      type: string
      pattern: '^([A-Fa-f0-9]{4}|[A-Fa-f0-9]{6})$'
    end:
      type: string
      pattern: '^([A-Fa-f0-9]{4}|[A-Fa-f0-9]{6})$'
    pattern:
      type: string
externalDocs:
  description: Documentation
  url: 'http://www.3gpp.org/ftp/Specs/archive/29_series/29.510/'

```

A.3 Nnrf_NFDiscovery API

```

openapi: 3.0.0
info:
  version: '1.PreR15.1.0'
  title: 'NRF NFDiscovery Service'
  description: 'NRF NFDiscovery Service'
servers:
  - url: '{apiRoot}/nnrf-disc/v1'
    variables:
      apiRoot:
        default: https://example.com
        description: apiRoot as defined in subclause subclause 4.4 of 3GPP TS 29.501
security:
  - {}
  - oAuth2ClientCredentials: []
paths:
  /nf-instances:
    get:
      summary: Search a collection of NF Instances
      operationId: SearchNFInstances
      tags:
        - NF Instances (Store)
      parameters:
        - name: target-nf-type
          in: query
          description: Type of the target NF
          required: true
          schema:
            $ref: 'TS29510_Nnrf_NFManagement.yaml#/components/schemas/NFType'
        - name: requester-nf-type
          in: query
          description: Type of the requester NF
          required: true
          schema:
            $ref: 'TS29510_Nnrf_NFManagement.yaml#/components/schemas/NFType'
        - name: service-names
          in: query
          description: Name of the service offered by the NF
          schema:
            type: array
            items:
              type: string
            minItems: 1
          style: form
          explode: false
        - name: requester-nf-instance-fqdn
          in: query
          description: FQDN of the requester NF
          schema:
            $ref: 'TS29510_Nnrf_NFManagement.yaml#/components/schemas/Fqdn'

```

- name: target-plmn
 - in: query
 - description: Id of the PLMN where the target NF is located
 - content:
 - application/json:
 - schema:
 - \$ref: 'TS29571_CommonData.yaml#/components/schemas/PlmnId'
- name: requester-plmn
 - in: query
 - description: Id of the PLMN where the NF issuing the Discovery request is located
 - content:
 - application/json:
 - schema:
 - \$ref: 'TS29571_CommonData.yaml#/components/schemas/PlmnId'
 - name: target-nf-instance-id
 - in: query
 - description: Identity of the NF instance being discovered
 - schema:
 - \$ref: 'TS29571_CommonData.yaml#/components/schemas/NfInstanceId'
 - name: target-nf-fqdn
 - in: query
 - description: FQDN of the NF instance being discovered
 - schema:
 - \$ref: 'TS29510_Nnrf_NFManagement.yaml#/components/schemas/Fqdn'
 - name: hnr-uri
 - in: query
 - description: Uri of the home NRF
 - schema:
 - \$ref: 'TS29571_CommonData.yaml#/components/schemas/Uri'
 - name: snssais
 - in: query
 - description: Slice info of the target NF
 - content:
 - application/json:
 - schema:
 - type: array
 - items:
 - \$ref: 'TS29571_CommonData.yaml#/components/schemas/Snssai'
 - name: dnn
 - in: query
 - description: Dnn supported by the SMF
 - schema:
 - \$ref: 'TS29571_CommonData.yaml#/components/schemas/Dnn'
 - name: nsi-list
 - in: query
 - description: NSI IDs that are served by the services being discovered
 - schema:
 - type: array
 - items:
 - type: string
 - style: form
 - explode: false
 - name: smf-serving-area
 - in: query
 - schema:
 - type: string
 - name: tai
 - in: query
 - description: Tracking Area Identity
 - content:
 - application/json:
 - schema:
 - \$ref: 'TS29571_CommonData.yaml#/components/schemas/Tai'
 - name: amf-region-id
 - in: query
 - description: AMF Region Identity
 - schema:
 - type: string
 - name: amf-set-id
 - in: query
 - description: AMF Set Identity
 - schema:
 - type: string
 - name: guami
 - in: query
 - description: Guami used to search for an appropriate AMF
 - schema:
 - \$ref: 'TS29571_CommonData.yaml#/components/schemas/Guami'

```

- name: supi
  in: query
  description: SUPI of the user
  schema:
    $ref: 'TS29571_CommonData.yaml#/components/schemas/Supi'
- name: ue-ipv4-address
  in: query
  description: IPv4 address of the UE
  schema:
    $ref: 'TS29571_CommonData.yaml#/components/schemas/Ipv4Addr'
- name: ue-ipv6-prefix
  in: query
  description: IPv6 prefix of the UE
  schema:
    $ref: 'TS29571_CommonData.yaml#/components/schemas/Ipv6Prefix'
- name: pgw-ind
  in: query
  description: Combined PGW-C and SMF or a standalone SMF
  schema:
    type: boolean
- name: pgw
  in: query
  description: PGW FQDN of a combined PGW-C and SMF
  schema:
    $ref: 'TS29510_Nnrf_NFManagement.yaml#/components/schemas/Fqdn'
- name: gpsi
  in: query
  description: GPSI of the user
  schema:
    $ref: 'TS29571_CommonData.yaml#/components/schemas/Gpsi'
- name: external-group-identity
  in: query
  description: external group identifier of the user
  schema:
    type: string
- name: data-set
  in: query
  description: data set supported by the NF
  schema:
    $ref: 'TS29510_Nnrf_NFManagement.yaml#/components/schemas/DataSetId'
- name: routing-indicator
  in: query
  description: routing indicator in SUCI
  schema:
    type: string
- name: group-id-list
  in: query
  description: Group IDs of the NFs being discovered
  schema:
    type: array
    items:
      type: string
    minItems: 1
    style: form
    explode: false
- name: supported-features
  in: query
  description: Features required to be supported by the target NF
  schema:
    $ref: 'TS29571_CommonData.yaml#/components/schemas/SupportedFeatures'
- name: If-None-Match
  in: header
  description: Validator for conditional requests, as described in IETF RFC 7232, 3.2
  schema:
    type: string
responses:
  '200':
    description: Expected response to a valid request
    content:
      application/json:
        schema:
          $ref: '#/components/schemas/SearchResult'
    headers:
      Cache-Control:
        description: Cache-Control containing max-age, described in IETF RFC 7234, 5.2
        schema:
          type: string
      ETag:

```

```

        description: Entity Tag containing a strong validator, described in IETF RFC 7232, 2.3
        schema:
            type: string
    '307':
        description: Temporary Redirect
    '400':
        $ref: 'TS29571_CommonData.yaml#/components/responses/400'
    '403':
        $ref: 'TS29571_CommonData.yaml#/components/responses/403'
    '404':
        $ref: 'TS29571_CommonData.yaml#/components/responses/404'
    '411':
        $ref: 'TS29571_CommonData.yaml#/components/responses/411'
    '413':
        $ref: 'TS29571_CommonData.yaml#/components/responses/413'
    '415':
        $ref: 'TS29571_CommonData.yaml#/components/responses/415'
    '500':
        $ref: 'TS29571_CommonData.yaml#/components/responses/500'
    '501':
        $ref: 'TS29571_CommonData.yaml#/components/responses/501'
    '503':
        $ref: 'TS29571_CommonData.yaml#/components/responses/503'
    default:
        $ref: 'TS29571_CommonData.yaml#/components/responses/default'
components:
    securitySchemes:
        oAuth2ClientCredentials:
            type: oauth2
            flows:
                clientCredentials:
                    tokenUrl: '/oauth2/token'
                    scopes: {}
    schemas:
        SearchResult:
            type: object
            properties:
                validityPeriod:
                    type: integer
                nfInstances:
                    type: array
                    items:
                        $ref: '#/components/schemas/NFProfile'
        NFProfile:
            type: object
            required:
                - nfInstanceId
                - nfType
                - nfStatus
            properties:
                nfInstanceId:
                    $ref: 'TS29571_CommonData.yaml#/components/schemas/NFInstanceId'
                nfType:
                    $ref: 'TS29510_Nnrf_NFManagement.yaml#/components/schemas/NFType'
                nfStatus:
                    $ref: 'TS29510_Nnrf_NFManagement.yaml#/components/schemas/NFStatus'
                plmn:
                    $ref: 'TS29571_CommonData.yaml#/components/schemas/PlmnId'
                sNssais:
                    type: array
                    items:
                        $ref: 'TS29571_CommonData.yaml#/components/schemas/Snssai'
                nsiList:
                    type: array
                    items:
                        type: string
                fqdn:
                    $ref: 'TS29510_Nnrf_NFManagement.yaml#/components/schemas/Fqdn'
                ipv4Address:
                    type: array
                    items:
                        $ref: 'TS29571_CommonData.yaml#/components/schemas/Ipv4Addr'
                ipv6Address:
                    type: array
                    items:
                        $ref: 'TS29571_CommonData.yaml#/components/schemas/Ipv6Addr'
                capacity:
                    type: integer

```



```

    minimum: 0
    maximum: 65535
  load:
    type: integer
    minimum: 0
    maximum: 100
  locality:
    type: string
  priority:
    type: integer
    minimum: 0
    maximum: 65535
  udrInfo:
    $ref: 'TS29510_Nnrf_NFManagement.yaml#/components/schemas/UdrInfo'
  udmInfo:
    $ref: 'TS29510_Nnrf_NFManagement.yaml#/components/schemas/UdmInfo'
  ausfInfo:
    $ref: 'TS29510_Nnrf_NFManagement.yaml#/components/schemas/AusfInfo'
  amfInfo:
    $ref: 'TS29510_Nnrf_NFManagement.yaml#/components/schemas/AmfInfo'
  smfInfo:
    $ref: 'TS29510_Nnrf_NFManagement.yaml#/components/schemas/SmfInfo'
  upfInfo:
    $ref: 'TS29510_Nnrf_NFManagement.yaml#/components/schemas/UpfInfo'
  pcfInfo:
    $ref: 'TS29510_Nnrf_NFManagement.yaml#/components/schemas/PcfInfo'
  bsfInfo:
    $ref: 'TS29510_Nnrf_NFManagement.yaml#/components/schemas/BsfInfo'
  customInfo:
    type: object
  recoveryTime:
    $ref: 'TS29571_CommonData.yaml#/components/schemas/DateTime'
  nfServices:
    type: array
    items:
      $ref: '#/components/schemas/NFService'
NFService:
  type: object
  required:
    - serviceInstanceId
    - serviceName
    - versions
    - scheme
    - nfServiceStatus
  properties:
    serviceInstanceId:
      type: string
    serviceName:
      $ref: 'TS29510_Nnrf_NFManagement.yaml#/components/schemas/ServiceName'
    versions:
      type: array
      items:
        $ref: 'TS29510_Nnrf_NFManagement.yaml#/components/schemas/NFServiceVersion'
    scheme:
      $ref: 'TS29571_CommonData.yaml#/components/schemas/UriScheme'
    nfServiceStatus:
      $ref: 'TS29510_Nnrf_NFManagement.yaml#/components/schemas/NFServiceStatus'
    fqdn:
      $ref: 'TS29510_Nnrf_NFManagement.yaml#/components/schemas/Fqdn'
    ipEndpoints:
      type: array
      items:
        $ref: 'TS29510_Nnrf_NFManagement.yaml#/components/schemas/IpEndPoint'
    apiPrefix:
      type: string
    defaultNotificationSubscriptions:
      type: array
      items:
        $ref:
'TS29510_Nnrf_NFManagement.yaml#/components/schemas/DefaultNotificationSubscription'
  capacity:
    type: integer
    minimum: 0
    maximum: 65535
  load:
    type: integer
    minimum: 0
    maximum: 100

```

```

    priority:
      type: integer
      minimum: 0
      maximum: 65535
    recoveryTime:
      $ref: 'TS29571_CommonData.yaml#/components/schemas/DateTime'
    supportedFeatures:
      $ref: 'TS29571_CommonData.yaml#/components/schemas/SupportedFeatures'
  externalDocs:
    description: Documentation
    url: 'http://www.3gpp.org/ftp/Specs/archive/29_series/29.510/'

```

A.4 NRF OAuth2 Authorization

```

openapi: 3.0.0
info:
  version: '1.PreR15.1.0'
  title: 'NRF OAuth2'
  description: 'NRF OAuth2 Authorization'
paths:
  /oauth2/token:
    post:
      summary: Access Token Request
      operationId: AccessTokenRequest
      tags:
        - Access Token Request
      security:
        - basic: []
      requestBody:
        content:
          application/x-www-form-urlencoded:
            schema:
              $ref: '#/components/schemas/AccessTokenReq'
            required: true
      responses:
        '200':
          description: Successful Access Token Request
          content:
            application/json:
              schema:
                $ref: '#/components/schemas/AccessTokenRsp'
          headers:
            Cache-Control:
              $ref: '#/components/headers/cache-control'
            Pragma:
              $ref: '#/components/headers/pragma'
        '400':
          description: Error in the Access Token Request
          content:
            application/json:
              schema:
                $ref: '#/components/schemas/AccessTokenErr'
          headers:
            Cache-Control:
              $ref: '#/components/headers/cache-control'
            Pragma:
              $ref: '#/components/headers/pragma'
components:
  securitySchemes:
    basic:
      type: http
      scheme: basic
  headers:
    cache-control:
      required: true
      schema:
        type: string
        enum:
          - no-store
    pragma:
      required: true
      schema:
        type: string
        enum:
          - no-cache
  schemas:
    AccessTokenReq:

```

```

format: x-www-form-urlencoded
required:
  - grant_type
  - nfInstanceId
  - nfType
  - targetNfType
  - scope
properties:
  grant_type:
    type: string
    enum:
      - client_credentials
  nfInstanceId:
    $ref: 'TS29571_CommonData.yaml#/components/schemas/NfInstanceId'
  nfType:
    $ref: 'TS29510_Nnrf_NFManagement.yaml#/components/schemas/NFType'
  targetNfType:
    $ref: 'TS29510_Nnrf_NFManagement.yaml#/components/schemas/NFType'
  scope:
    type: string
    pattern: '^([a-zA-Z0-9_]*[*]{0,1})$'
AccessTokenRsp:
  type: object
  required:
    - access_token
    - token_type
  properties:
    access_token:
      type: string
      description: JWS Compact Serialized representation of JWS signed JSON object
    (AccessTokenClaims)
    token_type:
      type: string
    expires_in:
      type: integer
    scope:
      type: string
      pattern: '^([a-zA-Z0-9_]*[*]{0,1})$'
AccessTokenClaims:
  type: object
  required:
    - issuer
    - subject
    - audience
    - scope
    - expiration
  properties:
    issuer:
      $ref: 'TS29571_CommonData.yaml#/components/schemas/NfInstanceId'
    subject:
      type: string
    audience:
      type: array
      items:
        $ref: 'TS29571_CommonData.yaml#/components/schemas/NfInstanceId'
    scope:
      type: string
      pattern: '^([a-zA-Z0-9_]*[*]{0,1})$'
    expiration:
      type: integer
AccessTokenErr:
  type: object
  required:
    - error
  properties:
    error:
      type: string
      enum:
        - invalid_request
        - invalid_client
        - invalid_grant
        - unauthorized_client
        - unsupported_grant_type
        - invalid_scope
    error_description:
      type: string
    error_uri:
      type: string

```

```
externalDocs:  
  description: Documentation  
  url: 'http://www.3gpp.org/ftp/Specs/archive/29_series/29.510/'
```

Annex B (informative): Change history

Date	Meeting	TDoc.	CR	Rev	Subject/Comment	New
2017-10	CT4#80	C4-175271			Initial draft	0.1.0
2017-10	CT4#80	C4-175395			Incorporation of agreed pCRs from CT4#80: C4-175109, C4-175272, C4-175274, C4-175363	0.2.0
2017-12	CT4#81	C4-176438			Incorporation of agreed pCRs from CT4#81: C4-176184, C4-176278, C4-176280, C4-176281, C4-176282	0.3.0
2018-01	CT4#82	C4-181392			Incorporation of agreed pCRs from CT4#82: C4-181348, C4-181351	0.4.0
2018-03	CT4#83	C4-182435			Incorporation of agreed pCRs from CT4#83: C4-182098, C4-182327, C4-182328, C4-182365, C4-182413	0.5.0
2018-04	CT4#84	C4-183517			Incorporation of agreed pCRs from CT4#84: C4-183450, C4-183451, C4-183452, C4-183487, C4-183488, C4-183490, C4-183491	0.6.0
2018-05	CT4#85	C4-184625			Incorporation of agreed pCRs from CT4#85: C4-184207, C4-184208, C4-184280, C4-184466, C4-184469, C4-184478, C4-184517, C4-184519, C4-184545, C4-184595, C4-184596, C4-184597, C4-184600, C4-184615, C4-184616, C4-184626	0.7.0
2018-06	CT#80	CP-181105			Presented for information and approval	1.0.0
2018-06	CT#80				Approved in CT#80.	15.0.0
2018-09	CT#81	CP-182012	0001	2	Implementing the Indirect Delivery method for the GET method to retrieve NF instances	15.1.0
2018-09	CT#81	CP-182093	0003	3	Defining the range of the priority and capacity attributes and aligning their usage with SRV RFC 2782	15.1.0
2018-09	CT#81	CP-182060	0004	-	Corrections to descriptions, references and SUPI parameter in Discovery Request	15.1.0
2018-09	CT#81	CP-182047	0006	2	SubscriptionData	15.1.0
2018-09	CT#81	CP-182045	0008	2	Error Cases	15.1.0
2018-09	CT#81	CP-182060	0009	2	Heart Beat Procedure	15.1.0
2018-09	CT#81	CP-182060	0010	1	Vendor-Specific NF Types	15.1.0
2018-09	CT#81	CP-182044	0011	3	Presence condition of service discovery query parameters	15.1.0
2018-09	CT#81	CP-182060	0012	4	Description of Inter-PLMN scenarios	15.1.0
2018-09	CT#81	CP-182060	0013	1	NF Service Versions	15.1.0
2018-09	CT#81	CP-182060	0014	1	Custom Headers	15.1.0
2018-09	CT#81	CP-182060	0015	1	Overall Clean-up	15.1.0
2018-09	CT#81	CP-182060	0016	-	Formatting of query parameters	15.1.0
2018-09	CT#81	CP-182060	0017	-	Editorial corrections	15.1.0
2018-09	CT#81	CP-182060	0018	2	Backup AMF	15.1.0
2018-09	CT#81	CP-182060	0020	1	NF Service Names	15.1.0
2018-09	CT#81	CP-182060	0023	-	CHF as service consumer	15.1.0
2018-09	CT#81	CP-182060	0024	3	Hierarchical NF discovery in recursion mode	15.1.0
2018-09	CT#81	CP-182060	0025	2	Hierarchical NF discovery in iteration mode	15.1.0
2018-09	CT#81	CP-182060	0026	-	Correction of Allowed NF Domains	15.1.0
2018-09	CT#81	CP-182060	0027	-	Correction of BsfnInfo data type	15.1.0
2018-09	CT#81	CP-182161	0028	1	IPv6 Prefix for NF / NF Service Address	15.1.0
2018-09	CT#81	CP-182060	0030	1	NF Set Id	15.1.0
2018-09	CT#81	CP-182060	0031	1	URI Scheme	15.1.0
2018-09	CT#81	CP-182060	0032	2	NRF service registration	15.1.0
2018-09	CT#81	CP-182060	0034	2	Discovery of combined SMF and PGW-C	15.1.0
2018-09	CT#81	CP-182163	0035	3	Support TAI Range for AMF/SMF and SUPI Range for PCF	15.1.0
2018-09	CT#81	CP-182060	0036	1	SUPI Range for PCF	15.1.0
2018-09	CT#81	CP-182164	0037	2	Scope for OAuth 2.0 Access Token Request	15.1.0
2018-09	CT#81	CP-182060	0039	1	Corrections to NotificationData and "supi" parameter in Discovery Request	15.1.0
2018-09	CT#81	CP-182060	0040	1	Group ID in Discovery Request	15.1.0
2018-09	CT#81	CP-182060	0041	1	Registering multiple Routing Indicators	15.1.0
2018-09	CT#81	CP-182060	0045	-	Description of Structured data types	15.1.0
2018-09	CT#81	CP-182060	0046	1	Service names in Discovery Request	15.1.0
2018-09	CT#81	CP-182060	0047	1	Resource structure presentation	15.1.0
2018-09	CT#81	CP-182060	0048	-	Default Notifications for UDM	15.1.0

2018-09	CT#81	CP-182060	0049	-	Cell ID in Discovery Request	15.1.0
2018-09	CT#81	CP-182046	0050	2	NRF Subscription Data	15.1.0
2018-09	CT#81	CP-182060	0051	1	AMF Discovery by 5G-AN	15.1.0
2018-09	CT#81	CP-182060	0052	1	Detecting NF Failure and Restart using the NRF	15.1.0
2018-09	CT#81	CP-182060	0053	2	NRF Subscription Lifespan	15.1.0
2018-09	CT#81	CP-182060	0054	1	NRF servers section in OpenAPI	15.1.0
2018-09	CT#81	CP-182060	0056	2	Default port number	15.1.0
2018-09	CT#81	CP-182162	0057	1	AMF Discovery Based on AMF Name	15.1.0
2018-09	CT#81	CP-182060	0058	-	API Version Update	15.1.0

History

Document history		
V15.0.0	September 2018	Publication
V15.1.0	October 2018	Publication