

# ETSI TS 132 154 V17.0.0 (2022-04)



**Digital cellular telecommunications system (Phase 2+) (GSM);  
Universal Mobile Telecommunications System (UMTS);  
LTE;  
Telecommunication management;  
Backward and Forward Compatibility (BFC);  
Concept and definitions  
(3GPP TS 32.154 version 17.0.0 Release 17)**



---

**Reference**

RTS/TSGS-0532154vh00

---

**Keywords**

GSM,LTE,UMTS

**ETSI**

650 Route des Lucioles  
F-06921 Sophia Antipolis Cedex - FRANCE

---

Tel.: +33 4 92 94 42 00 Fax: +33 4 93 65 47 16

Siret N° 348 623 562 00017 - APE 7112B  
Association à but non lucratif enregistrée à la  
Sous-Préfecture de Grasse (06) N° w061004871

---

**Important notice**

---

The present document can be downloaded from:

<http://www.etsi.org/standards-search>

The present document may be made available in electronic versions and/or in print. The content of any electronic and/or print versions of the present document shall not be modified without the prior written authorization of ETSI. In case of any existing or perceived difference in contents between such versions and/or in print, the prevailing version of an ETSI deliverable is the one made publicly available in PDF format at [www.etsi.org/deliver](http://www.etsi.org/deliver).

Users of the present document should be aware that the document may be subject to revision or change of status.

Information on the current status of this and other ETSI documents is available at

<https://portal.etsi.org/TB/ETSIDeliverableStatus.aspx>

If you find errors in the present document, please send your comment to one of the following services:

<https://portal.etsi.org/People/CommitteeSupportStaff.aspx>

If you find a security vulnerability in the present document, please report it through our  
Coordinated Vulnerability Disclosure Program:

<https://www.etsi.org/standards/coordinated-vulnerability-disclosure>

---

**Notice of disclaimer & limitation of liability**

---

The information provided in the present deliverable is directed solely to professionals who have the appropriate degree of experience to understand and interpret its content in accordance with generally accepted engineering or other professional standard and applicable regulations.

No recommendation as to products and services or vendors is made or should be implied.

No representation or warranty is made that this deliverable is technically accurate or sufficient or conforms to any law and/or governmental rule and/or regulation and further, no representation or warranty is made of merchantability or fitness for any particular purpose or against infringement of intellectual property rights.

In no event shall ETSI be held liable for loss of profits or any other incidental or consequential damages.

Any software contained in this deliverable is provided "AS IS" with no warranties, express or implied, including but not limited to, the warranties of merchantability, fitness for a particular purpose and non-infringement of intellectual property rights and ETSI shall not be held liable in any event for any damages whatsoever (including, without limitation, damages for loss of profits, business interruption, loss of information, or any other pecuniary loss) arising out of or related to the use of or inability to use the software.

---

**Copyright Notification**

---

No part may be reproduced or utilized in any form or by any means, electronic or mechanical, including photocopying and microfilm except as authorized by written permission of ETSI.

The content of the PDF version shall not be modified without the written authorization of ETSI.

The copyright and the foregoing restriction extend to reproduction in all media.

© ETSI 2022.  
All rights reserved.

---

# Intellectual Property Rights

## Essential patents

IPRs essential or potentially essential to normative deliverables may have been declared to ETSI. The declarations pertaining to these essential IPRs, if any, are publicly available for **ETSI members and non-members**, and can be found in ETSI SR 000 314: "*Intellectual Property Rights (IPRs); Essential, or potentially Essential, IPRs notified to ETSI in respect of ETSI standards*", which is available from the ETSI Secretariat. Latest updates are available on the ETSI Web server (<https://ipr.etsi.org/>).

Pursuant to the ETSI Directives including the ETSI IPR Policy, no investigation regarding the essentiality of IPRs, including IPR searches, has been carried out by ETSI. No guarantee can be given as to the existence of other IPRs not referenced in ETSI SR 000 314 (or the updates on the ETSI Web server) which are, or may be, or may become, essential to the present document.

## Trademarks

The present document may include trademarks and/or tradenames which are asserted and/or registered by their owners. ETSI claims no ownership of these except for any which are indicated as being the property of ETSI, and conveys no right to use or reproduce any trademark and/or tradename. Mention of those trademarks in the present document does not constitute an endorsement by ETSI of products, services or organizations associated with those trademarks.

**DECT™**, **PLUGTESTS™**, **UMTS™** and the ETSI logo are trademarks of ETSI registered for the benefit of its Members. **3GPP™** and **LTE™** are trademarks of ETSI registered for the benefit of its Members and of the 3GPP Organizational Partners. **oneM2M™** logo is a trademark of ETSI registered for the benefit of its Members and of the oneM2M Partners. **GSM®** and the GSM logo are trademarks registered and owned by the GSM Association.

---

# Legal Notice

This Technical Specification (TS) has been produced by ETSI 3rd Generation Partnership Project (3GPP).

The present document may refer to technical specifications or reports using their 3GPP identities. These shall be interpreted as being references to the corresponding ETSI deliverables.

The cross reference between 3GPP and ETSI identities can be found under <http://webapp.etsi.org/key/queryform.asp>.

---

# Modal verbs terminology

In the present document "**shall**", "**shall not**", "**should**", "**should not**", "**may**", "**need not**", "**will**", "**will not**", "**can**" and "**cannot**" are to be interpreted as described in clause 3.2 of the [ETSI Drafting Rules](#) (Verbal forms for the expression of provisions).

"**must**" and "**must not**" are **NOT** allowed in ETSI deliverables except when used in direct citation.

# Contents

Intellectual Property Rights .....	2
Legal Notice .....	2
Modal verbs terminology.....	2
Foreword.....	4
Introduction .....	4
1 Scope .....	5
2 References .....	5
3 Definitions and abbreviations.....	5
3.1 Definitions .....	5
3.2 Abbreviations .....	6
4 BC between 3GPP TS 32-series specifications.....	6
4.1 Prerequisite.....	6
4.2 Rules.....	7
5 BC context.....	8
5.1 General .....	8
5.2 IRP level.....	9
5.3 IRPAgent level .....	10
6 BC Recommendations .....	12
6.1 Requirement .....	12
6.2 IS-level .....	12
6.3 SS-level .....	12
6.3.1 CORBA .....	12
6.3.2 Void .....	12
6.3.3 File format description XML .....	12
6.3.4 File format description ASN.1 .....	12
6.3.5 SOAP .....	12
<b>Annex A (informative): BC and Conformance Tests .....</b>	<b>13</b>
<b>Annex B (informative): Change history .....</b>	<b>14</b>
History .....	15

---

# Foreword

This Technical Specification has been produced by the 3<sup>rd</sup> Generation Partnership Project (3GPP).

The contents of the present document are subject to continuing work within the TSG and may change following formal TSG approval. Should the TSG modify the contents of the present document, it will be re-released by the TSG with an identifying change of release date and an increase in version number as follows:

Version x.y.z

where:

- x the first digit:
  - 1 presented to TSG for information;
  - 2 presented to TSG for approval;
  - 3 or greater indicates TSG approved document under change control.
- y the second digit is incremented for all changes of substance, i.e. technical enhancements, corrections, updates, etc.
- z the third digit is incremented when editorial only changes have been incorporated in the document.

---

# Introduction

The Itf-N partitions two groups of interacting entities called IRPManager(s) and IRPAgent(s).

The interactions between an IRPManager and IRPAgent are specified by the set of IRP specifications the IRPAgent supports, and which the IRPManager uses.

Each YyyIRP (where "Yyy" stands for Alarm, BasicCM, etc.) permits a manager to, via `getIRPVersion`, inspect its supported IRPVersion(s). Each such IRPVersion uniquely identifies one supported Interface IRP SS.

Each YyyIRP may also permit an IRPManager to, via `getNRMIRPVersions`, inspect its supported NRM IRPVersion(s). Each such IRPVersion uniquely identifies one supported NRM IRP SS.

The 3GPP IRP specifications are expected to evolve. For example, 3GPP Release 6 specifications include more or modified features compared to the corresponding set in Release 5.

An IRPManager and IRPAgent, with implementations conformant to the same IRP specification (at the same IRPVersion(s)) will be able to communicate.

However, an upgrade of the IRPVersion, if not performed by both IRPAgent and IRPManager, can result in inter-working failure if Backward Compatibility (BC) issues are not addressed.

The present document is applicable/relevant to a system context of a group of interacting IRPManagers and IRPAgents where some members are using one IRPVersion while others are using an upgraded IRPVersion.

---

# 1 Scope

The present document gives recommendations to develop future IRP specifications in a Backward Compatible (BC) way so that the group of IRPManager(s) and IRPAgent(s) are not forced to be upgraded in lock step.

The business case for supporting such group, as described above, is complex. It may not relate to the functions of the supported IRPs alone. Rather, it can relate to the cost of coordination of IRPVersion upgrades, the cost of maintaining an old IRPVersion and the cost of using single-vendor or multi-vendor IRPAgents. These considerations are operator deployment scenarios specific.

Clause 4 specifies the Recommendations and clause 5 describes the system context where the Recommendations are applicable.

**Editor's Note:** The "forward compatability" part is FFS.

---

# 2 References

The following documents contain provisions which, through reference in this text, constitute provisions of the present document.

- References are either specific (identified by date of publication and/or edition number or version number) or non-specific.
- For a specific reference, subsequent revisions do not apply.
- For a non-specific reference, the latest version applies. In the case of a reference to a 3GPP document (including a GSM document), a non-specific reference implicitly refers to the latest version of that document *in the same Release as the present document*.

- [1] 3GPP TS 32.101: "Telecommunication management; Principles and high level requirements".
- [2] 3GPP TS 32.102: "Telecommunication management; Architecture".
- [3] 3GPP TS 32.111-2: "Telecommunication management; Fault Management; Part 2: Alarm Integration Reference Point (IRP): Information Service (IS)".
- [4] 3GPP TS 32.311: "Telecommunication management; Generic Integration Reference Point (IRP) management; Requirements".

---

# 3 Definitions and abbreviations

## 3.1 Definitions

For the purposes of the present document, the following terms and definitions apply:

**Element Manager (EM):** See 3GPP TS 32.101 [1].

**IRPAgent:** See 3GPP TS 32.102 [2].

**IRPManager:** See 3GPP TS 32.102 [2].

**IRPVersion:** See "IRP document version number string" or "IRPVersion" in 3GPP TS 32.311 [4] clause 3.1.

**Network Manager (NM):** See 3GPP TS 32.101 [1].

## 3.2 Abbreviations

For the purposes of the present document, the following abbreviations apply:

ASN.1	Abstract Syntax Notation One
BC	Backward Compatible or Backward Compatibility
CMIP	Common Management Information Protocol
CORBA	Common Object Request Broker Architecture
EM	Element Manager
IS	Information Service
IRP	Integration Reference Point
NE	Network Element
NM	Network Manager
NRM	Network Resource Model
VSE	Vendor Specific Extension (to 3GPP IRP specification)
SS	Solution Set
XML	eXtensible Markup Language

---

## 4 BC between 3GPP TS 32-series specifications

### 4.1 Prerequisite

The words old and new, when qualifying an IRPVersion, refer to a single Interface IRPVersion of the same kind, e.g. Alarm IRP. They also refer to NRM IRPVersion of the same kind, e.g. Core NRM. The 'new' refers to a later release compared to the 'old'.

The words old and new, when qualifying an IRPManager, refer to an entity that is using the old or the new (Interface or NRM) IRPVersion.

The words old and new, when qualifying an IRPAgent, refer to an entity that contains an IRP that is supporting the old or the new (Interface or NRM) IRPVersion.

In majority cases, an IRPAgent instance contains multiple IRPs, each of which is using a particular Interface IRPVersion. In these cases, each Recommendation statement should be repeated to cover all IRPs involved.

The Recommendations do not imply that equipment vendors shall always supply their new IRPAgents in compliance to the solutions satisfying the Recommendations. The Recommendations simply identify the expected behaviours of a new system when it, claiming BC, interacts with an old system. Whether or not an IRPAgent should satisfy the Recommendations is a decision of the equipment vendor/supplier.

The Recommendations do not imply that the next release of 3GPP Interface IRP or NRM IRP specification must be BC (to the older one). Whether or not a new release of an Interface IRP or NRM IRP should be BC to its older version is a decision of the 3GPP specification author, on a case-by-case basis.

## 4.2 Rules

[REC-1] An old IRPManager inter-operates with an old IRPAgent-A and a new IRPAgent-B.

The interaction shall be successful in that the IRPManager can obtain the network management services (capabilities and features) defined by the old IRPVersion from both IRPAgents.

The IRPManager needs not have knowledge of new network management services defined by the new IRPVersion.

[REC-2] A new IRPManager inter-operates with a new IRPAgent-A and an old IRPAgent-B.

The interaction shall be successful in that the IRPManager can obtain the network management services defined by (a) the new IRPVersion from IRPAgent-A and (b) the old IRPVersion from IRPAgent-B.

NOTE: If the next minor and/or major release of 3GPP Interface IRP or NRM IRP specification is BC (to the older one), one could reduce or eliminate the difficult coordination task to introduce IRPVersion upgrades in a large management domain containing multiple IRPManagers and IRPAgents. It can be more cost-effective if IRPVersion upgrades to individual entity (i.e. IRPManager and IRPAgent) are done at different times.



## 5 BC context

### 5.1 General

This clause defines the context under which the requirements specified in the present document are applicable.

The word 'old' qualifies the related entity (i.e. the AlarmIRP of an IRPAgent instance or Alarm IRPManager) that is using an older 3GPP IRPVersion (called old version). The word 'new' qualifies the related entity that is using a newer (upgraded) 3GPP IRPVersion.

**EXAMPLE:** A hypothetical 3GPP TS 32.123 V6.0.0 is considered the old version with reference to 3GPP TS 32.123 V6.1.0. The two versions in question can belong to the same or different major releases (e.g. Rel-5 or Rel-6).

The box labelled EM in figure 5.1 conveys the same idea as the box of the same label in the System Context-A of other IRP specifications such as Alarm IRP IS 3GPP TS 32.111-2 [3].

One or all EM-labelled boxes of figure 5.1 can be interchanged with the NE-labelled box (see System Context-B of other IRP specifications such as Alarm IRP IS 3GPP TS 32.111-2 [3]). The NE entities are not shown in order to make the figure easier to read.

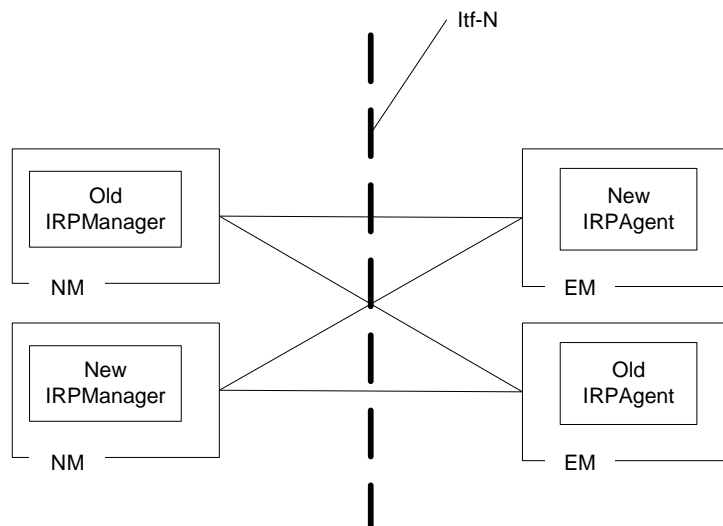

**Figure 5.1: Overall BC System Context**

In general, an IRPAgent instance may contain several Interface YyyIRP instances and associated supporting Yyy NRM IRPs (where one IRP can be for example Alarm IRP, Test Management IRP, or "Notification IRP", etc and where the other IRP can be for example Generic IRP). The Interface and NRM YyyIRP specifications of particular IRPVersion(s) together specify the behaviour of an Interface IRP and the supporting NRM IRP (s).

**NOTE:** The IRPVersion concept is related to the IRP.  
The IRPVersion concept is not related to the IRPAgent as this may contain multiple IRPs.

Given this background, the BC issues are addressed at two separate but related levels as described in clauses 5.2 and 5.3.

## 5.2 IRP level

The two diagrams here illustrate conceptually the two possible contexts when we address BC at this IRP level.

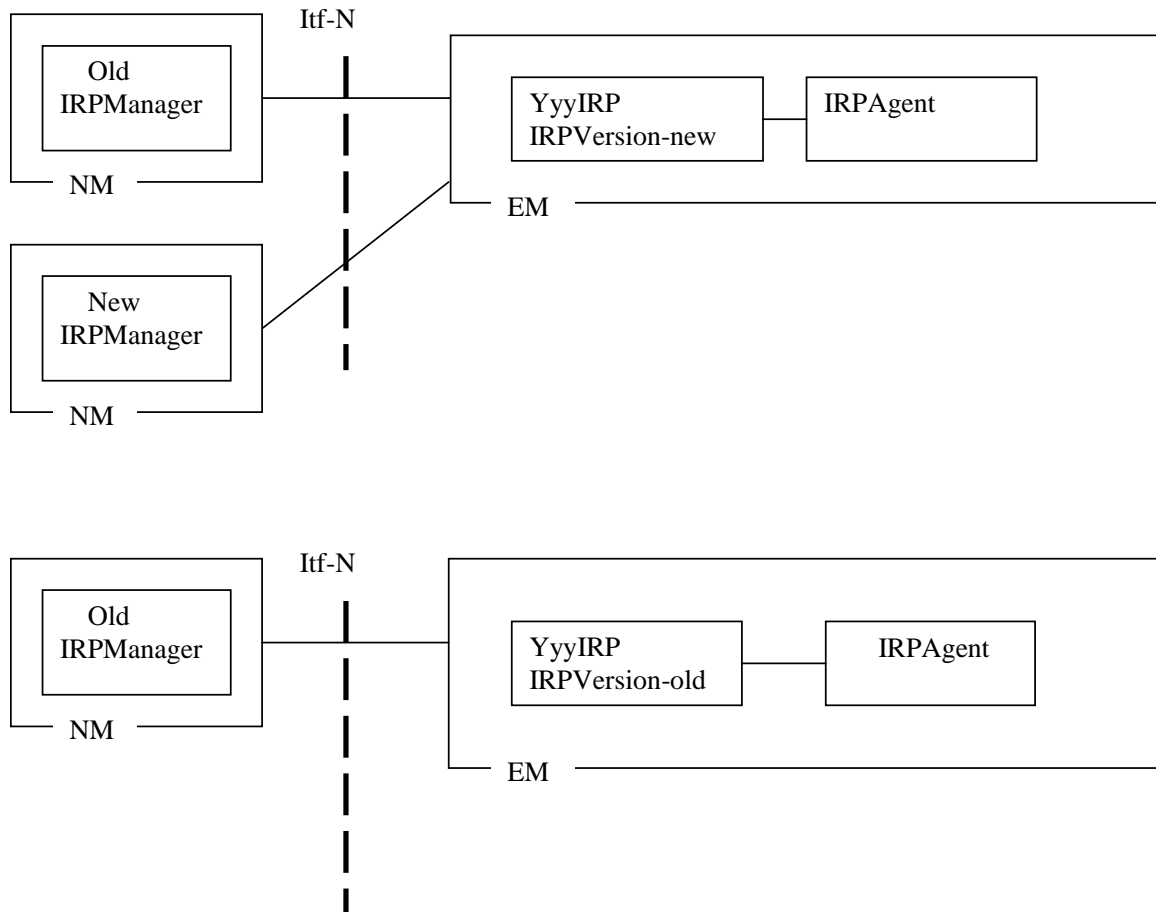

**Figure 5.2: Specification BC System Context**

An YyyIRP instance supports a particular Interface IRPVersion and a particular set of NRM IRPVersions.  
 An IRPManager uses a particular Interface IRPVersion and a particular set of NRM IRPVersions.

If an YyyIRP instance supports Interface IRPVersion-X and NRM IRPVersions-Y, then it can interact successfully with an IRPManager that uses the same IRPVersions. This is illustrated by the case of the "Old IRPManager" and the "Old IRPAgent" of the bottom diagram (and note that the diagram does not show the NRM IRP version support).

If this same YyyIRP instance upgrades its Interface IRPVersion-X to X2 that is BC to X, then it can interact successfully with an IRPManager that uses the Interface IRPVersion-X or IRPVersion-X2. The top diagram of figure 5.2 illustrates this case (and note that the diagram does not show the NRM IRP version support).

If this same YyyIRP instance upgrades its NRM IRPVersion-Y to Y2 that is BC to Y, then it can interact successfully with an IRPManager that uses the NRM IRPVersion-Y or NRM IRPVersion-Y2. The top diagram of figure 5.2 illustrated this case (and note that the diagram does not show the NRM IRP version support).

Given the above, the BC issues addressed at the present document level are:

- How to determine if an IRP IS or SS specification (Interface IRP or NRM IRP) is BC to an earlier version ?  
 This can be addressed in another way.  
 What are the BC-rules that the author of a 3GPP IRP specification should use to extend an old-version to produce a new version that can claim BC (to that old-version) ?

At this level, the specification author shall define BC-rules for each of the following:

- Interface IRP- Requirements.
- Interface IRP IS.
- Interface IRP SS(s).
- NRM IRP requirements.
- NRM IRP IS.
- NRM IRP SS(s).
- Data Definition IRP IS.
- Data Definition IRP SS(s).

One reason why the specification author addresses BC at this IRP level is that, for certain technologies, such as CORBA, it is possible that one entity using (compiles with) one IRP SS specification (i.e. the CORBA SS) while the other communicating entity using a new but BC version can interact successfully (such as the IRPManager and IRPAgent-A of [REC-1]).

### 5.3 IRPAgent level

Figure 5.3 illustrates the two possible contexts when addressing BC at this IRPAgent level.

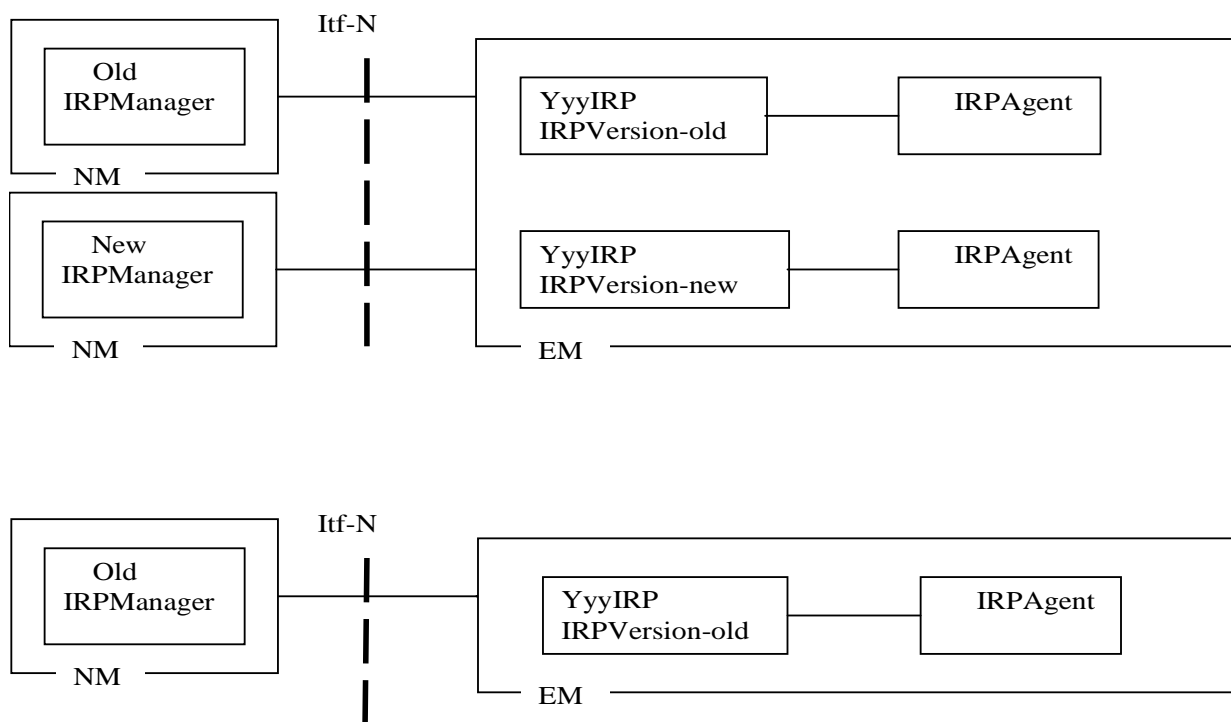

**Figure 5.3: System/Implementation BC System Context**

NOTE 1: An IRPAgent instance contains multiple YyyIRP instances such as AlarmIRP, NotificationIRP, TestManagementIRP, etc. Each YyyIRP instance implements/supports the corresponding YyyIRP specification of a particular IRPVersion.

Suppose IRPAgent-A contains YyyIRP of Interface IRPVersion-4, YyyIRP of Interface IRPVersion-5 and YyyIRP of Interface IRPVersion-6 and all IRPs support NRM IRPVersion-7 (see Note 2), this IRPAgent-A is BC if it can inter-operate successfully with the following:

- IRPManager 1 using Interface IRPVersion-4 or 3 using NRM IRPVersion-7 or 6.
- IRPManager 2 using Interface IRPVersion-5 or 4 using NRM IRPVersion-7 or 6.
- IRPManager 3 using Interface IRPVersion-6 or 5 using NRM IRPVersion-7 or 6.

NOTE 2: All IRPs contained by the same IRPAgent instance should support the same set of NRM IRPVersions.

It is anticipated that the IRPAgent level BC solution includes:

- An IRPAgent service allowing IRPManager to discover all the IRPAgent supported Interface IRPVersion(s).
- An IRPAgent service allowing IRPManager to discover the IRPAgent supported NRM IRPVersion(s).
- An IRPAgent service allowing IRPManager to discover the reference/address of the IRP instance (of the IRPAgent) supporting a particular Interface IRPVersion.

The two diagrams in figure 5.3 illustrate the two possible ways to support BC at this so-called IRPAgent level.

The IRPVersion-new needs not to be BC to IRPVersion-old. In the case that IRPVersion-new is BC to IRPVersion-old, it is EM supplier's choice if "IRP level" or "IRPAgent level" solution will be used to support BC. In the case that the IRPVersion-new is not BC to IRPVersion-old, then the EM supplier will have no choice but to use "IRPAgent level" solution if it wants its EM to support BC.

NOTE 3: IRPAgent service supporting "discovery" (as stated by the above three bullets) is not illustrated in the two diagrams

---

## 6 BC Recommendations

### 6.1 Requirement

The Requirement specification is in subclause 4.2 Rules.

### 6.2 IS-level

There is no text specifically written related to IS-level specification for BC systems. The two system context diagrams of subclauses 5.2 and 5.3 would be necessary and sufficient to describe the management services provided by EM to support the so-called Old IRPManager and New IRPManager.

### 6.3 SS-level

#### 6.3.1 CORBA

For CORBA Solution Set, the IRPAgent level (see subclause 5.3) context would be used.

#### 6.3.2 Void

#### 6.3.3 File format description XML

**Editor's Note:** This part is FFS.

#### 6.3.4 File format description ASN.1

**Editor's Note:** This part is FFS.

#### 6.3.5 SOAP

**Editor's Note:** This part is FFS.

## Annex A (informative): BC and Conformance Tests

This annex illustrates that:

- an IRP, implementing a new-version IRP specification that is BC to an old-version IRP specification, may or may not be compliant to the old-version IRP specification.

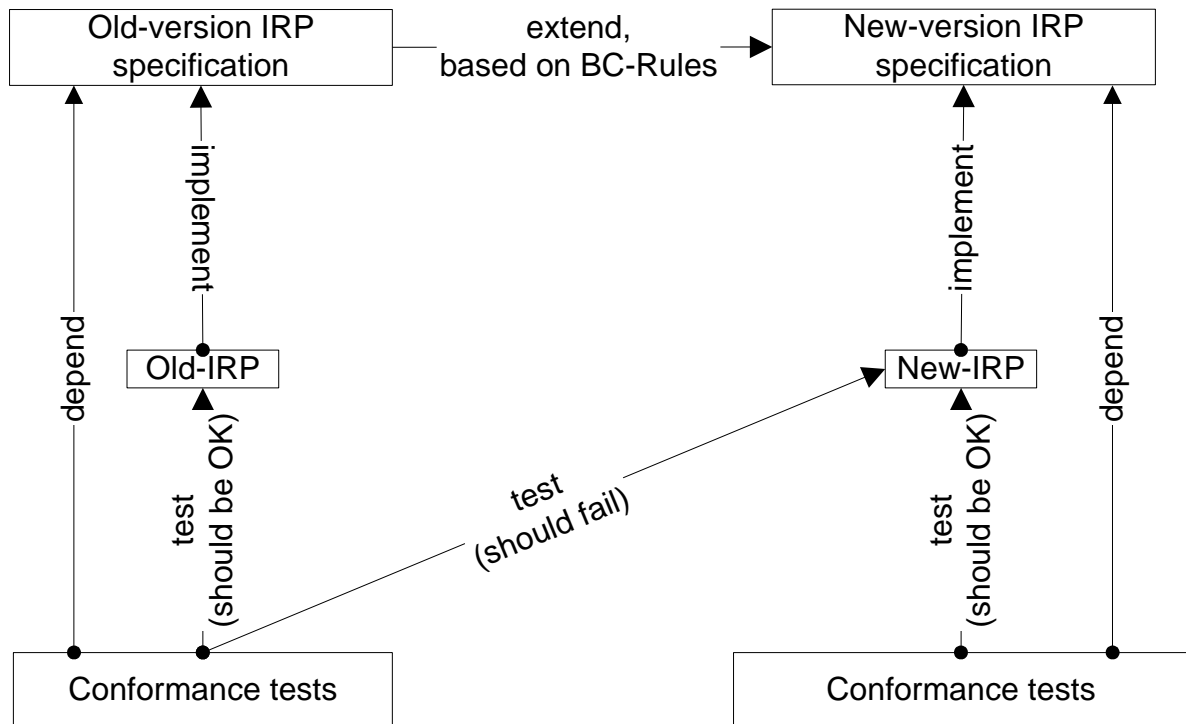

**Figure A.1: BC and Conformance Tests Scenario**

Suppose 3GPP has an older-version IRP specification (the "Old-version IRP specification" box) and there is a valid/correct implementation (the "Old-IRP" box). Suppose also that 3GPP produce a "New-version IRP specification" by extending the "Old-version IRP specification" using the BC-rules.

The "New-IRP" should interwork with IRPManager that uses the "New-version IRP specification". This "New-IRP" should also interwork with IRPManager that uses the "Old-version IRP specification".

The "Old-IRP" should pass the conformance test that is based on (see "depend" relation) the "Old-version IRP specification".

Likewise, the "New-IRP" should pass the conformance test that is based on the "New-version IRP specification".

However, this "New-IRP" may not be able to pass the conformance test that is based on "Old-version IRP specification" (see "test (should fail)" relation).

Likewise, the "Old-IRP" should not be able to pass the conformance test that is based on "New-Version IRP specification".

## Annex B (informative): Change history

Change history								
Date	TSG #	TSG Doc.	CR	Rev	Subject/Comment	Cat	Old	New
Mar 2007	SA_35	SP-070065	--	--	Submitted to TSG SA#35 for Information	--	1.0.0	
Jun 2007	SA_36	SP-070283	--	--	Submitted to TSG SA#36 for Approval	--	2.0.0	7.0.0
Dec 2008	SA_42	--	--	--	Upgrade to Release 8	-	7.0.0	8.0.0
Dec 2009	-	-	-	-	Update to Rel-9 version (MCC)	-	8.0.0	9.0.0
Mar 2010	SA_47	SP-100036	001	--	Introduction of SOAP SS	C	9.0.0	10.0.0
2012-09	-	-	-	-	Update to Rel-11 version (MCC)		10.0.0	<b>11.0.0</b>
2014-10	-	-	-	-	Update to Rel-12 version (MCC)		11.0.0	<b>12.0.0</b>
2016-01	-	-	-	-	Update to Rel-13 version (MCC)		12.0.0	<b>13.0.0</b>
2017-03	SA#75	-	-	-	Promotion to Release 14 without technical change		13.0.0	<b>14.0.0</b>

Change history							
Date	Meeting	TDoc	CR	Rev	Cat	Subject/Comment	New version
2018-06						Update to Rel-15 version (MCC)	15.0.0
2020-07	-	-	-	-	-	Update to Rel-16 version (MCC)	<b>16.0.0</b>
2022-03	-	-	-	-	-	Update to Rel-17 version (MCC)	<b>17.0.0</b>

---

# History

<b>Document history</b>		
V17.0.0	April 2022	Publication