

ETSI TS 132 240 V8.5.0 (2009-01)

Technical Specification

**Digital cellular telecommunications system (Phase 2+);
Universal Mobile Telecommunications System (UMTS);
LTE;
Telecommunication management;
Charging management;
Charging architecture and principles
(3GPP TS 32.240 version 8.5.0 Release 8)**



Reference

RTS/TSGS-0532240v850

Keywords

GSM, LTE, UMTS

ETSI

650 Route des Lucioles
F-06921 Sophia Antipolis Cedex - FRANCE

Tel.: +33 4 92 94 42 00 Fax: +33 4 93 65 47 16

Siret N° 348 623 562 00017 - NAF 742 C
Association à but non lucratif enregistrée à la
Sous-Préfecture de Grasse (06) N° 7803/88

Important notice

Individual copies of the present document can be downloaded from:

<http://www.etsi.org>

The present document may be made available in more than one electronic version or in print. In any case of existing or perceived difference in contents between such versions, the reference version is the Portable Document Format (PDF). In case of dispute, the reference shall be the printing on ETSI printers of the PDF version kept on a specific network drive within ETSI Secretariat.

Users of the present document should be aware that the document may be subject to revision or change of status. Information on the current status of this and other ETSI documents is available at

<http://portal.etsi.org/tb/status/status.asp>

If you find errors in the present document, please send your comment to one of the following services:

http://portal.etsi.org/chaicor/ETSI_support.asp

Copyright Notification

No part may be reproduced except as authorized by written permission.
The copyright and the foregoing restriction extend to reproduction in all media.

© European Telecommunications Standards Institute 2009.
All rights reserved.

DECTTM, **PLUGTESTS**TM, **UMTS**TM, **TIPHON**TM, the TIPHON logo and the ETSI logo are Trade Marks of ETSI registered for the benefit of its Members.

3GPPTM is a Trade Mark of ETSI registered for the benefit of its Members and of the 3GPP Organizational Partners.

LTETM is a Trade Mark of ETSI currently being registered

for the benefit of its Members and of the 3GPP Organizational Partners.

GSM[®] and the GSM logo are Trade Marks registered and owned by the GSM Association.

Intellectual Property Rights

IPRs essential or potentially essential to the present document may have been declared to ETSI. The information pertaining to these essential IPRs, if any, is publicly available for **ETSI members and non-members**, and can be found in ETSI SR 000 314: *"Intellectual Property Rights (IPRs); Essential, or potentially Essential, IPRs notified to ETSI in respect of ETSI standards"*, which is available from the ETSI Secretariat. Latest updates are available on the ETSI Web server (<http://webapp.etsi.org/IPR/home.asp>).

Pursuant to the ETSI IPR Policy, no investigation, including IPR searches, has been carried out by ETSI. No guarantee can be given as to the existence of other IPRs not referenced in ETSI SR 000 314 (or the updates on the ETSI Web server) which are, or may be, or may become, essential to the present document.

Foreword

This Technical Specification (TS) has been produced by ETSI 3rd Generation Partnership Project (3GPP).

The present document may refer to technical specifications or reports using their 3GPP identities, UMTS identities or GSM identities. These should be interpreted as being references to the corresponding ETSI deliverables.

The cross reference between GSM, UMTS, 3GPP and ETSI identities can be found under <http://webapp.etsi.org/key/queryform.asp>.

Contents

Intellectual Property Rights	2
Foreword.....	2
Foreword.....	5
1 Scope	6
2 References	8
3 Definitions, symbols and abbreviations	9
3.1 Definitions	9
3.2 Symbols.....	11
3.3 Abbreviations	12
4 Common charging architecture and framework	15
4.1 Charging mechanisms	16
4.1.1 Offline charging.....	16
4.1.2 Online charging	16
4.2 High level common architecture	17
4.3 Charging functions	18
4.3.1 Offline charging functions	18
4.3.1.1 Charging Trigger Function.....	19
4.3.1.2 Charging Data Function	20
4.3.1.3 Charging Gateway Function.....	20
4.3.2 Online Charging Functions	21
4.3.2.1 Charging Trigger Function.....	21
4.3.2.2 Online Charging System	22
4.3.2.2.1 Online Charging Function	22
4.3.2.2.2 S-CSCF online charging / IMS Gateway Function	22
4.3.2.2.3 Rating Function	22
4.3.2.2.4 Account Balance Management Function.....	23
4.3.2.3 CDR generation for online charged subscribers.....	23
4.4 Reference points	24
4.4.1 Offline charging reference points	24
4.4.1.1 Rf.....	24
4.4.1.2 Gz.....	24
4.4.1.3 Ga.....	24
4.4.1.4 Bx.....	25
4.4.1.5 Wf	25
4.4.2 Online charging reference points	25
4.4.2.1 Ro.....	25
4.4.2.2 CAP.....	25
4.4.2.3 Gy.....	25
4.4.2.4 Re	26
4.4.2.5 Rc	26
4.4.2.6 Wo.....	26
4.5 Architecture mapping	26
4.5.1 Offline mapping.....	26
4.5.2 Online mapping	28
5 Charging principles	29
5.1 Charging data generation and quota supervision	29
5.2 Charging data transfer	31
5.2.1 Charging data transfer in offline charging	31
5.2.1.1 Transfer of charging events via Rf.....	32
5.2.1.2 Transfer of CDRs via Ga.....	32
5.2.1.3 Transfer of CDR files via Bx	33
5.2.2 Charging Data Transfer in Online Charging.....	34
5.3 Charging levels and correlation.....	36

5.3.1	Bearer level charging	36
5.3.1.1	Bearer charging based on bearer / tele- / supplementary service	36
5.3.1.2	Flow based bearer charging.....	36
5.3.2	Subsystem level charging	36
5.3.3	Service level charging.....	36
5.3.4	Charging data correlation.....	36
5.3.4.1	Intra-level correlation.....	37
5.3.4.2	Inter-level correlation.....	37
5.3.4.3	Inter-network correlation	37
5.4	Charging data configuration	38
5.5	Charging information utilisation	40
5.5.1	Subscriber charging	40
5.5.1.1	Calling Party Charging.....	40
5.5.1.2	Alternate Party Charging for IMS	40
5.5.2	Credit control and balance management.....	41
5.5.2.1	Use of credit pooling	41
5.5.3	Inter-operator settlement of Charges	41
5.5.3.1	Inter-PLMN accounting	41
5.5.3.2	'Visitors' from other PLMNs	41
5.5.3.4	'Home' subscribers roaming in other PLMNs	41
5.5.3.5	Fixed network operators and other service providers.....	41
5.5.4	Advice of Charge	42
Annex A (informative):	Bibliography	43
Annex B (informative):	Change history	45
History		46

Foreword

This Technical Specification has been produced by the 3rd Generation Partnership Project (3GPP).

The contents of the present document are subject to continuing work within the TSG and may change following formal TSG approval. Should the TSG modify the contents of the present document, it will be re-released by the TSG with an identifying change of release date and an increase in version number as follows:

Version x.y.z

where:

- x the first digit:
 - 1 presented to TSG for information;
 - 2 presented to TSG for approval;
 - 3 or greater indicates TSG approved document under change control.
- y the second digit is incremented for all changes of substance, i.e. technical enhancements, corrections, updates, etc.
- z the third digit is incremented when editorial only changes have been incorporated in the document.

1 Scope

The present document is part of a series of documents that specify charging functionality and charging management in GSM/UMTS and EPS networks. The GSM/UMTS and EPS core network charging architecture and principles are specified in the present document, which thus provides an umbrella for other charging management TSs that specify:

- the content of the CDRs per domain / subsystem /service (offline charging);
- the content of real-time charging events per domain / subsystem /service (online charging);
- the functionality of online and offline charging for those domains / subsystems / services;
- the interfaces that are used in the charging framework to transfer the charging information (i.e. CDRs or charging events).

The purposes of the present document are:

- to lay down common principles of charging in the network; and
- to specify a logical common charging architecture that applies to all 3GPP domains, subsystems and services.

A set of domain/subsystem/service specific TSs covers the bearer (CS, PS, WLAN domains), subsystem (IMS) and service (MMS, LCS, etc.) levels, respectively, in the 32.25x, 32.26x and 32.27x TS number range. These TSs describe the mapping of the common architecture specified in the present document onto the specific domain/subsystem/service and the scenarios and information for online and offline charging that are specific to the domain/subsystem/service. They are commonly referred to as the 'middle tier (charging) TSs'.

A set of TSs in the 32.280 and the 32.29x range cover common aspects such as the Advice of Charge service. CDR parameter and syntax descriptions, online and offline charging applications, and the charging interactions within the network (CDR transfer) as well as between the network and the Billing Domain (CDR file transfer).

The complete document structure for these TSs is outlined in the following figure.

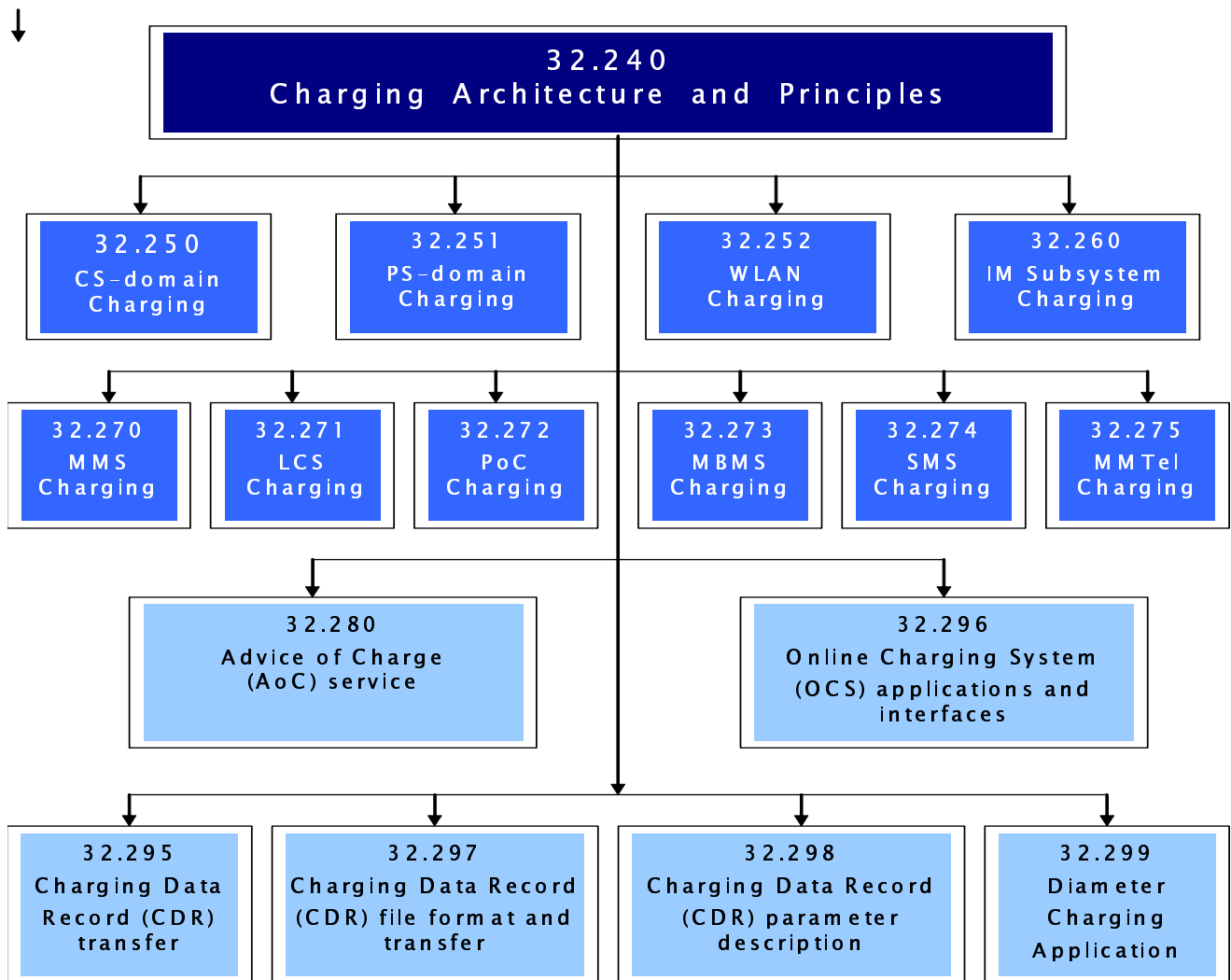

Figure 1: Charging specifications structure

All terms, definitions and abbreviations used in the present document, that are common across 3GPP TSs, are defined in the 3GPP Vocabulary, 3GPP TR 21.905 [100]. Those that are common across charging management in GSM/UMTS domains, services or subsystems are provided in the present document (umbrella TS), and are copied into clause 3 of the other TSs depicted in the figure, for ease of reading. Finally, those items that are specific to the present document are defined exclusively in the present document.

Furthermore, requirements that govern the charging work are specified in 3GPP TS 22.115 [101].

2 References

The following documents contain provisions which, through reference in this text, constitute provisions of the present document.

- References are either specific (identified by date of publication, edition number, version number, etc.) or non-specific.
- For a specific reference, subsequent revisions do not apply.
- For a non-specific reference, the latest version applies. In the case of a reference to a 3GPP document (including a GSM document), a non-specific reference implicitly refers to the latest version of that document *in the same Release as the present document*.

[1]- [9]	Void.
[10]	3GPP TS 32.250: "Telecommunication management; Charging management; Circuit Switched (CS) domain charging".
[11]	3GPP TS 32.251: "Telecommunication management; Charging management; Packet Switched (PS) domain charging".
[12]- [29]	Void.
[30]	3GPP TS 32.270: "Telecommunication management; Charging management; Multimedia Messaging Service (MMS) charging".
[31]- [49]	Void.
[50]	3GPP TS 32.299: "Telecommunication management; Charging management; Diameter charging application".
[51]	3GPP TS 32.298: "Telecommunication management; Charging management; Charging Data Record (CDR) parameter description".
[52]	3GPP TS 32.297: "Telecommunication management; Charging management; Charging Data Record (CDR) file format and transfer".
[53]	3GPP TS 32.296: "Telecommunication management; Charging management; Online Charging System (OCS) applications and interfaces".
[54]	3GPP TS 32.295: "Telecommunication management; Charging management; Charging Data Record (CDR) transfer".
[55]- [68]	Void.
[69]	3GPP TS 32.280: "Telecommunication management; Charging management; Advice of Charge (AoC) service".
[70]	Void.
[71]	3GPP TS 23.203: "Policy and charging control architecture".
[72]- [99]	Void.
[100]	3GPP TR 21.905: "Vocabulary for 3GPP Specifications".
[101]	3GPP TS 22.115 "Service aspects; Charging and billing".
[102]- [199]	Void.
[200]- [206]	Void.
[207]	3GPP TS 23.078: "Customized Applications for Mobile network Enhanced Logic (CAMEL); Stage 2".

[208]- [209]	Void.
[210]	3GPP TS 23.234: "3GPP system to Wireless Local Area Network (WLAN) interworking; System description".
[211]- [299]	Void.
[300]	ITU-T Recommendation D.93: "Charging and accounting in the international land mobile telephone service (provided via cellular radio systems)".
[301]- [399]	Void.
[400]- [401]	Void.
[402]	IETF RFC 4006: "Diameter Credit Control Application".

3 Definitions, symbols and abbreviations

3.1 Definitions

For the purposes of the present document, the terms and definitions defined in 3GPP TR 21.905 [100] and the following apply:

2G- / 3G-: prefixes 2G- and 3G- refer to functionality that supports only GSM or UMTS, respectively, e.g. 2G-SGSN refers only to the GSM functionality of an SGSN.

accounting: process of apportioning charges between the Home Environment, Serving Network and Subscriber.

accounting meter record: record containing one or more counters employed to register the usage of resources en masse. Includes simple event counters and/ or cumulative call second counters.

Advice of Charge (AoC): real-time display of the network utilization charges incurred by the Mobile Station. The charges are displayed in the form of charging units. If a unit price is stored by the MS then the display may also include the equivalent charge in the home currency.

AoC service: combination of one or more services, both basic and supplementary, together with a number of other charging relevant parameters to define a customized service for the purpose of advice of charge.

billing: function whereby CDRs generated by the charging function(s) are transformed into bills requiring payment.

Billing Domain: part of the operator network, which is outside the core network, which receives and processes CDR files from the core network charging functions. It includes functions that can provide billing mediation and billing or other (e.g. statistical) end applications. It is only applicable to offline charging (see 'Online Charging System' for equivalent functionality in online charging).

CAMEL: network feature that provides the mechanisms to support operator specific services even when roaming outside HPLMN.

CAMEL subscription information: identifies a subscriber as having CAMEL services.

chargeable event: activity utilizing telecommunications network resources and related services for:

- user to user communication (e.g. a single call, a data communication session or a short message); or
- user to network communication (e.g. service profile administration); or
- inter-network communication (e.g. transferring calls, signalling, or short messages); or
- mobility (e.g. roaming or inter-system handover); and
- that the network operator may want to charge for.

As a minimum, a chargeable event characterises the resource / service usage and indicates the identity of the involved end user(s).

charged party: user involved in a chargeable event that has to pay parts or the whole charges of the chargeable event, or a third party paying the charges caused by one or all users involved in the chargeable event, or a network operator.

charging: function within the telecommunications network and the associated OCS/BD components whereby information related to a chargeable event is collected, formatted, transferred and evaluated in order to make it possible to determine usage for which the charged party may be billed (offline charging) or the subscriber's account balance may be debited (online charging).

Charging Data Record (CDR): formatted collection of information about a chargeable event (e.g. time of call set-up, duration of the call, amount of data transferred, etc) for use in billing and accounting. For each party to be charged for parts of or all charges of a chargeable event a separate CDR shall be generated, i.e. more than one CDR may be generated for a single chargeable event, e.g. because of its long duration, or because more than one charged party is to be charged.

charging event: set of charging information forwarded by the CTF towards the CDF (offline charging) or towards the OCS (online charging). Each charging event matches exactly one chargeable event.

circuit switched domain: domain within GSM / UMTS in which information is transferred in circuit switched mode.

credit control: mechanism which directly interacts in real-time with an account and controls or monitors the charges, related to the service usage. Credit control is a process of: checking if credit is available, credit reservation, deduction of credit from the end user account when service is completed and refunding of reserved credit not used.

domain: part of a communication network that provides resources using a certain bearer technology.

Fully qualified Partial CDR (FQPC): partial CDR that contains a complete set of the fields specified for the CDR type in the respective middle tier TS. This includes all the mandatory and conditional fields as well as those fields that the PLMN operator has provisioned to be included in the CDR. The first Partial CDR shall be a Fully Qualified Partial CDR.

GPRS: packet switched bearer and radio services for GSM and UMTS systems.

(GSM only): qualifier indicating that this clause or paragraph applies only to a GSM system. For multi-system cases this is determined by the current serving radio access network.

in GSM,...: qualifier indicating that this paragraph applies only to GSM Systems

in UMTS,...: qualifier indicating that this paragraph applies only to UMTS Systems

inter-system change: change of radio access between different radio access technologies such as GSM and UMTS

middle tier (charging) TS: term used for the 3GPP charging TSs that specify the domain / subsystem / service specific, online and offline, charging functionality. These are all the TSs in the numbering range from 3GPP TS 32.250 to 3GPP TS 32.279, e.g. 3GPP TS 32.250 [10] for the CS domain, or 3GPP TS 32.270 [30] for the MMS service. Currently, there is only one "tier 1" TS in 3GPP, which is the present document that specifies the charging architecture and principles. Finally, there are a number of top tier TSs in the 32.29x numbering range ([50] ff) that specify common charging aspects such as parameter definitions, encoding rules, the common billing domain interface or common charging applications.

near real-time: near real-time charging and billing information is to be generated, processed, and transported to a desired conclusion in less than 1 minute.

observed IMEI ticket: record used to describe an EIR relevant event e.g. a blacklisted IMEI.

offline charging: charging mechanism where charging information **does not** affect, in real-time, the service rendered.

online charging: charging mechanism where charging information can affect, in real-time, the service rendered and therefore a direct interaction of the charging mechanism with bearer/session/service control is required.

Online Charging System: the entity that performs real-time credit control. Its functionality includes transaction handling, rating, online correlation and management of subscriber accounts/balances.

packet switched domain: domain in which data is transferred between core network elements.

partial CDR: CDR that provides charging information on part of a user session. A long session may be covered by several partial CDRs. Two formats are considered for Partial CDRs. One that contains all of the necessary fields (FQPC); the second has a reduced format (RPC).

real-time: real-time charging and billing information is to be generated, processed, and transported to a desired conclusion in less than 1 second.

Reduced Partial CDR (RPC): partial CDRs that only provide mandatory fields and information regarding changes in the session parameters relative to the previous partial CDR. For example, location information is not repeated in these CDRs if the subscriber did not change its location.

settlement: payment of amounts resulting from the accounting process.

subscriber: entity (associated with one or more users) that is engaged in a Subscription with a service provider. The subscriber is allowed to subscribe and unsubscribe services, to register a user or a list of users authorised to enjoy these services, and also to set the limits relative to the use that associated users make of these services.

successful call: connection that reaches the communication or data transfer phase e.g. the "answered" state for speech connections. All other connection attempts are regarded as unsuccessful.

tariff period: part of one (calendar) day during which a particular tariff is applied. Defined by the time at which the period commences (the switch-over time) and the tariff to be applied after switch-over

tariff: set of parameters defining the network utilization charges for the use of a particular bearer / session / service.

UMTS only: qualifier indicating that this clause or paragraph applies only to a UMTS system. For multi-system cases this is determined by the current serving radio access network.

user: entity, not part of the 3GPP System, which uses network resources by means of a subscription. The user may or may not be identical to the subscriber holding that subscription.

User Equipment (UE): device allowing a user access to network services. For the purpose of 3GPP specifications the interface between the UE and the network is the radio interface. A User Equipment can be subdivided into a number of domains, the domains being separated by reference points. Currently defined domains are the USIM and ME Domains. The ME Domain can further be subdivided into several components showing the connectivity between multiple functional groups. These groups can be implemented in one or more hardware devices. An example of such connectivity is the TE – MT interface. Further, an occurrence of a User Equipment is an MS for GSM as defined in GSM TS 04.02 (GSM Public Land Mobile Network (PLMN) Access Reference Configuration). From 3GPP TR 21.905: "Vocabulary for 3GPP Specifications" [100].

3.2 Symbols

For the purposes of the present document the following symbols apply:

A	Interface between an MSC and a BSC.
Bc	Reference point for the CDR file transfer from the Circuit Switched CGF to the BD.
Bi	Reference point for the CDR file transfer from the IMS CGF to the BD.
Bl	Reference point for the CDR file transfer from the GMLC CGF to the BD.
Bm	Reference point for the CDR file transfer from the MMS CGF to the BD.
Bo	Reference point for the CDR file transfer from the OCF CGF to the BD.
Bp	Reference point for the CDR file transfer from the Packet Switched CGF to the BD.
Bs	Reference point for the CDR file transfer for CAMEL services to the BD, i.e. from the SCF CGF to the BD.
Bt	Reference point for the CDR file transfer from the PoC CGF to the BD.
Bw	Reference point for the CDR file transfer from the WLAN CGF to the BD.
Bx	Reference point for CDR file transfer between any (generic) 3G domain, subsystem or service CGF and a BD.
CAP	Reference point for CAMEL between a network element with integrated SSF and the OCS.
Ga	Reference point for CDR transfer between a CDF and the CGF.
Gb	Interface between an SGSN and a BSC.
Gc	Interface between an GGSN and an HLR.
Gd	Interface between an SMS-GMSC and an SGSN, and between a SMS-IW MSC and an SGSN.
Gf	Interface between an SGSN and an EIR.

Gi	Interface between the Packet-Switched domain and an external packet data network.
Gn	Interface between two GSNs within the same PLMN.
Gp	Interface between two GSNs in different PLMNs.
Gr	Interface between an SGSN and an HLR.
Gs	Interface between an SGSN and an MSC/VLR.
Gx	Reference point between a PCRF and a PCEF.
Gy	Online charging reference point between a PCEF and an OCS.
Gz	Offline charging reference point between a PCEF and a CGF.
Iu	Interface between the RNS and the core network.
kbit/s	Kilobits per second. 1 kbit/s = 2 ¹⁰ bits per second.
Lr	Interface between Gateway MLCs.
Mbit/s	Megabits per second. 1 Mbit/s = 2 ²⁰ bits per second.
Mc	Interface between the MGW and (G)MSC server.
Rf	Offline charging reference point between a 3G network element and the CDF.
Ro	Online charging reference point between a 3G network element and the OCS.
Rx	Reference point between the PCRF and an AF.
Um	Interface between the Mobile Station (MS) and the GSM fixed network part.
Uu	Interface between the User Equipment (UE) and the UMTS fixed network part.
Wf	Offline charging reference point between a 3GPP WLAN CTF and the CDF.
Wo	Online charging reference point between a 3GPP WLAN CTF and the OCS.

3.3 Abbreviations

For the purposes of the present document, the following abbreviations apply:

3G	3 rd Generation
3GPP	3 rd Generation Partnership Project
AF	Application Function
AMF	Account Balance Management Function
AoC	Advice of Charge
APN	Access Point Name
AS	Application Server
BD	Billing Domain
BS	Bearer Services
BSC	Base Station Controller
BSS	Base Station Subsystem
BTS	Base Transceiver Station
CAMEL	Customized Applications for Mobile network Enhanced Logic
CAP	CAMEL Application Part
CDF	Charging Data Function
CDR	Charging Data Record
CG	Charging Gateway
CGF	Charging Gateway Function
CS	Circuit Switched
CSCF	Call Session Control Function (I-Interrogating; P-Proxy; and S-Serving)
CTF	Charging Trigger Function
EBCF	Event Based Charging Function
ECUR	Event Charging with Unit Reservation
EIR	Equipment Identity Register
EPS	Evolved Packet System
E-UTRAN	Evolved Universal Terrestrial Radio Access Network
FQPC	Fully Qualified Partial CDR
GGSN	Gateway GPRS Support Node
GMLC	Gateway MLC
GMSC	Gateway MSC
GPRS	General Packet Radio Service
GSM	Global System for Mobile communication
gsmSCF	GSM Service Control Function
gsmSSF	GSM Service Switching Function
GSN	GPRS Support Node (either SGSN or GGSN)
HLR	Home Location Register

HPLMN	Home PLMN
HSCSD	High Speed Circuit Switched Data
IBCF	Interconnect Border Control Function
IEC	Immediate Event Charging
IETF	Internet Engineering Task Force
IMEI	International Mobile Equipment Identity
IMS GWF	IMS GateWay Function
IMS	IP Multimedia Subsystem
IMSI	International Mobile Subscriber Identity
IP	Internet Protocol
ISC	IMS Service Control
ISDN	Integrated Services Digital Network
ITU-T	International Telecommunication Union - Telecommunications standardization sector
LAC	Location Area Code
LAN	Local Area Network
LCS	Location Services
MAP	Mobile Application Part
ME	Mobile Equipment
MGW	Media GateWay
MLC	Mobile Location Center
MMI	Man-Machine Interface
MMS	Multimedia Messaging Service
MMSE	Multimedia Messaging Service Environment
MO	Mobile Originated
MOC	MO Call
MRF	Media Resource Function
MRFC	MRF Controller
MS	Mobile Station
MSC	Mobile Services Switching Centre
MSISDN	Mobile Station ISDN number
MT	Mobile Terminated
MTC	MT Call
NE	Network Element
OCF	Online Charging Function
OCS	Online Charging System
PCEF	Policy and Charging Enforcement Function
PCRF	Policy and Charging Rules Function
PDN	Packet Data Network
PDP	Packet Data Protocol, e.g. IP
PLMN	Public Land Mobile Network
PoC	Push-to-talk over Cellular
PS	Packet-Switched
PSPDN	Packet-Switched Public Data Network
QoS	Quality of Service
RF	Rating Function
RNC	Radio Network Controller
RNS	Radio Network Subsystem
RPC	Reduced Partial CDR
SBCF	Session Based Charging Function
SCCP	Signalling Connection Control Part
SCF	Service Control Function
SCUR	Session Charging with Unit Reservation
SGSN	Serving GPRS Support Node
SIM	Subscriber Identity Module
SMS	Short Message Service
SSF	Service Switching Function
TAP	Transferred Account Procedure
TR	Technical Report
TS	Technical Specification
UE	User Equipment
UMTS	Universal Mobile Telecommunications System
USIM	Universal SIM

VAS	Value Added Service
VLR	Visitor Location Register
VMSC	Visited MSC
VPLMN	Visited PLMN
WLAN	Wireless LAN

4 Common charging architecture and framework

The main requirements and high-level principles for charging and billing across the domains, subsystems and services that comprise a GSM or UMTS PLMN are established in the 3GPP TS 22.115 [101]. In order to fulfil these requirements, appropriate charging information needs to be generated and collected by the network elements of the PLMN and forwarded to appropriate charging and billing systems.

Several logical charging functions are needed in the network in order to provide the functionality described above for online and offline charging, respectively. These charging functions are specified in detail in this clause, together with the reference points that are used to transfer charging information between those functions. While the overall possibilities that exist within the 3GPP standards for the physical mapping of these logical functions are described in the present document, the exact situation that applies to the various domains, subsystems and services of the network is specified in the middle tier charging TS that is specific to that domain/subsystem/service (i.e. TS 32.25x - TS 32.27x).

In offline charging, the charging information is transferred from the network to the Billing Domain (BD), where it is processed for billing and/or statistical purposes, at the discretion of the PLMN operator. While the internal functions of the BD are outside the scope of 3GPP standardisation, the reference point for the charging information transfer from the network to the BD does form a part of the 3GPP standards and is therefore also specified in the present clause.

In online charging, the charging information is transferred from the network to the Online Charging System (OCS). The OCS, in turn, may have an offline charging reference point used to forward charging information to the BD that is similar in scope and intent to the offline charging case described in the previous paragraph. Those areas of the OCS that form part of the 3GPP standards (functions and reference points) are also described in the present clause. All other aspects of the OCS are outside the scope of 3GPP standards.

4.1 Charging mechanisms

GSM/UMTS/EPC networks provide functions that implement offline and/or online charging mechanisms on the bearer (e.g. EPC), subsystem (e.g. IMS) and service (e.g. MMS) levels. In order to support these charging mechanisms, the network performs real-time monitoring of resource usage on the above three levels in order to detect the relevant chargeable events. The charging levels are further described in clause 5.3.

In offline charging, the resource usage is reported from the network to the Billing Domain after the resource usage has occurred. In online charging, a subscriber account, located in an online charging system, is queried prior to granting permission to use the requested network resource(s).

Typical examples of network resource usage are a voice call of certain duration, the transport of a certain volume of data, or the submission of a MM of a certain size. The network resource usage requests may be initiated by the UE (MO case) or by the network (MT case).

Offline and online charging may be performed simultaneously and independently for the same chargeable event. Clause 5.5 provides further insight into potential utilisation of the charging information produced by the offline and online charging mechanisms.

4.1.1 Offline charging

Offline charging is a process where charging information for network resource usage is collected concurrently with that resource usage. The charging information is then passed through a chain of logical charging functions that are further explained in clause 4.3.1. At the end of this process, CDR files are generated by the network, which are then transferred to the network operator's Billing Domain for the purpose of subscriber billing and/or inter-operator accounting (or additional functions, e.g. statistics, at the operator's discretion). The BD typically comprises post-processing systems such as the operator's billing system or billing mediation device.

In conclusion, offline charging is a mechanism where charging information does not affect, in real-time, the service rendered.

4.1.2 Online charging

Online charging is a process where charging information for network resource usage is collected concurrently with that resource usage in the same fashion as in offline charging. However, authorization for the network resource usage must be obtained by the network prior to the actual resource usage to occur. This authorization is granted by the Online Charging System upon request from the network.

When receiving a network resource usage request, the network assembles the relevant charging information and generates a charging event towards the OCS in real-time. The OCS then returns an appropriate resource usage authorization. The resource usage authorization may be limited in its scope (e.g. volume of data or duration), therefore the authorization may have to be renewed from time to time as long as the user's network resource usage persists.

Note that the charging information utilized in online charging is not necessarily identical to the charging information employed in offline charging.

In conclusion, online charging is a mechanism where charging information can affect, in real-time, the service rendered and therefore a direct interaction of the charging mechanism with the control of network resource usage is required.

4.2 High level common architecture

The architectural differences between the domains (e.g. PS), services (e.g. MMS) and subsystems (e.g. the IMS) affect the way in which the charging functions are embedded within the different domains, services and subsystems. However, the functional requirements for charging are always the same across all domains, services and subsystems. This clause describes a common approach for the definition of the logical charging functions, which provides a ubiquitous logical charging architecture for all GSM and UMTS network domains, subsystems and services that are relevant for charging standardisation.

It should be noted that this common charging architecture provides only a common logical view and the actual domain / service / subsystem specific charging architecture depends on the domain / service / subsystem in question. The physical mapping of the common logical architecture onto each domain, subsystem or service is described in the respective middle tier charging TS, i.e. the TSs 32.25x, 32.26x and 32.27x number range.

Figure 4.2 provides an overview of the logical ubiquitous charging architecture and the information flows for offline and online charging. The common charging functions are detailed further in clauses 4.3.1 for offline charging and 4.3.2 for online charging. The reference points are further specified in clause 4.4.

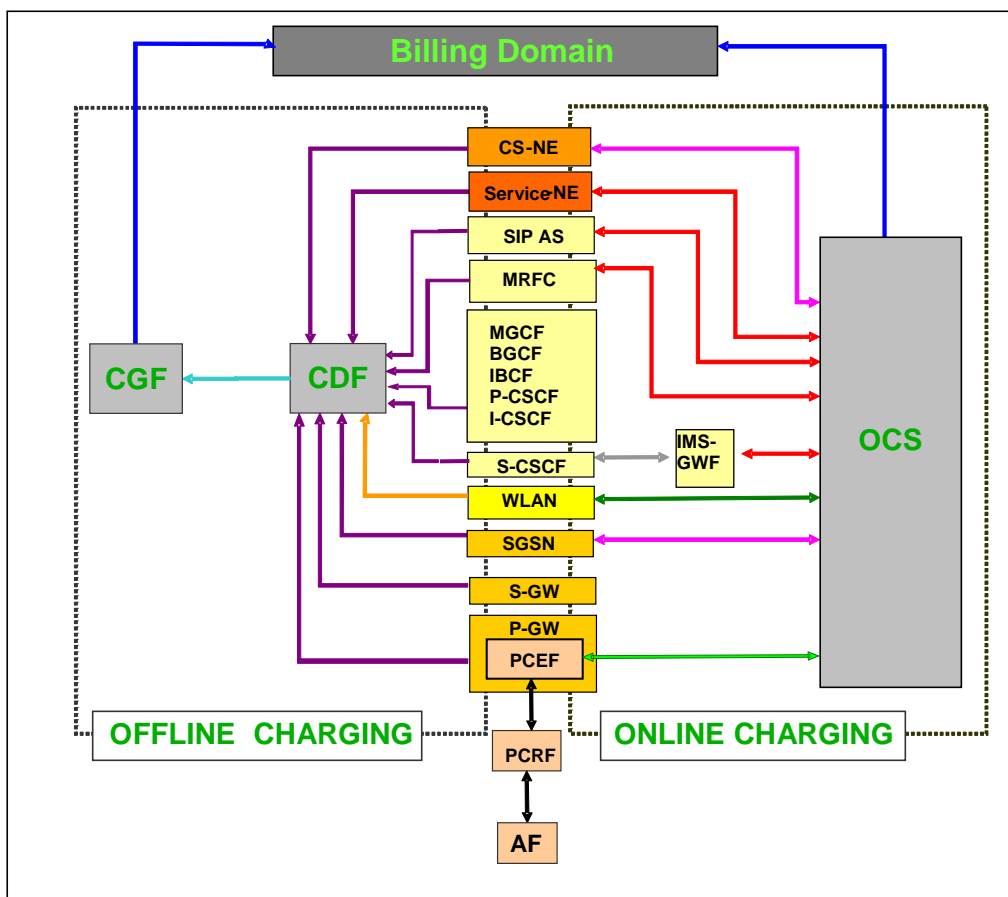

NOTE: The Service-NE are defined in the 3GPP specification range of TS 32.27x.

Figure 4.2: Logical ubiquitous charging architecture and information flows

Figure 4.2 includes all network elements / systems (top to bottom: CS-NE all the way through to the PCEF) for which charging is defined within 3GPP standards. The arrows indicate logical information flows on the Rf, Wf, Ga, Bx, ISC, Ro, Wo, CAP, and Gy reference points. No inference should be drawn from the figure with respect to the physical implementation of interfaces and charging functions.

NOTE 1: On the PCEF, 3GPP TS 23.203 [71] specifies the Gy reference point for online flow based bearer charging and the Gz reference point for offline flow based bearer charging. However, from the charging architecture perspective, Gy is functionally equivalent to the Ro reference point, Gz is functionally equivalent to the Ga reference point for Legacy PS domain, and to the Ga or the Rf reference point for Evolved PS domain. . Therefore, Ga or Rf and Ro are used throughout the present document also in conjunction with PCEF charging. This simplification ensures a consistent architectural view, as specified below, for all online and offline charging architectural aspects. Refer to clause 5.3.1.2 for a description of flow based bearer charging.

NOTE 2: On WLAN, 3GPP TS 23.234 [210] specifies the Wo reference point for WLAN online charging and the Wf reference point for WLAN offline charging. However, from the charging architecture perspective, these reference points are functionally equivalent to the Ro and Rf reference points, respectively. Therefore, Rf and Ro are used throughout the present document also in conjunction with WLAN charging. This simplification ensures a consistent architectural view, as specified below, for all online and offline charging architectural aspects.

4.3 Charging functions

4.3.1 Offline charging functions

Figure 4.3.1 provides an overview of the offline part of the common charging architecture. The figure depicts the logical charging functions as well as the reference points between these functions and to the Billing Domain.

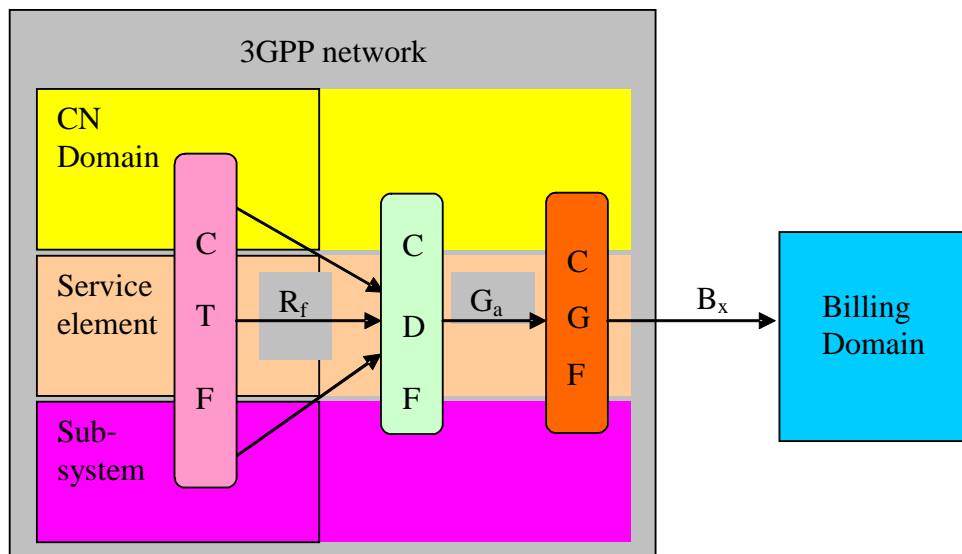

- CTF:** Charging Trigger Function
- CDF:** Charging Data Function
- CGF:** Charging Gateway Function
- BD:** Billing Domain. This may also be a billing system/ billing mediation device.

Figure 4.3.1: Logical ubiquitous offline charging architecture

NOTE: Although not visualised in this figure, the OCS can also produce CDRs, i.e. act as a domain / service / subsystem element with embedded CTF, see clause 4.3.2.3.

4.3.1.1 Charging Trigger Function

The Charging Trigger Function (CTF) generates charging events based on the observation of network resource usage as described in clause 4.1.1. In every network and service element that provides charging information, the CTF is the focal point for collecting the information pertaining to chargeable events within the network element, assembling this information into matching charging events, and sending these charging events towards the Charging Data Function. The CTF is therefore a mandatory, integrated component in all network elements that provide offline charging functionality, as depicted in figure 4.2. It is made up of two functional blocks:

- Accounting Metrics Collection

The process that monitors signalling functions for calls, service events or sessions established by the network users, or the handling of user traffic for these calls, service events or sessions, or service delivery to the user via these calls, service events or sessions. It is required to provide metrics that identify the user and the user's consumption of network resources and/or services in real-time. The exact behaviour and functionality of this process e.g.:

- trigger conditions for collection of charging information,
- information elements to collect,
- which service events, signalling or user traffic to monitor,
- relationship to services / bearers / sessions,

depends on functions / services that the NE provides. The Account Metrics Collection can therefore be considered as the network element dependent part of the CTF.

Depending on implementation choice, NE functions (e.g. the handling of service events or signalling / user traffic) may be distributed among multiple physical 'devices' within the NE. In order to be able to capture the required charging information from the service events or signalling / user traffic, the design of the Accounting Metrics Collection has to match the physical design / distribution of these functions within the NE. This implies that in case of such distributed NE functionality, the Accounting Metrics Collection becomes a distributed functionality itself.

- Accounting Data Forwarding

This process receives the collected accounting metrics and determines the occurrence of chargeable events from a set of one or more of these metrics. It then assembles charging events that match the detected chargeable events, and forwards the charging events towards the Charging Data Function via the Rf reference point. The charging events provide information pertinent to the chargeable event, i.e. characterising the network resource usage together with an identification of the involved user(s). There is no assumption of any synchronisation between the reception of individual accounting metrics, however, it must be possible for the Accounting Data Forwarding to complete its overall functionality per charging event in real-time.

While the exact information received by the Account Data Forwarding from the Account Metrics Collection, and the relevant chargeable events, are specific to each type of network element, the overall functionality of receiving, assembling and forwarding the charging information can be considered generic. Hence the Accounting Data Forwarding is considered the NE independent part of the CTF.

The behaviour of the CTF with respect to the definition of the chargeable events, the matching charging events and the information elements to collect is specified per domain, subsystem and service in the respective middle tier charging 3GPP TS ([10] – [49]).

4.3.1.2 Charging Data Function

The Charging Data Function (CDF) receives charging events from the Charging Trigger Function via the Rf reference point. It then uses the information contained in the charging events to construct CDRs. This procedure is characterised by the following conditions:

- CDRs may be constructed from single charging events, i.e. a 1:1 relation between event and CDR.
- CDRs may be constructed from a set of several charging events, i.e. a n:1 relation between event and CDR.
- Each charging event is used for exactly one CDR, i.e. a 1:n relation between event and CDR (with n>1) is not possible.
- Multiple charging events that are used to create a single CDR may not necessarily be of the same type.
- There is no requirement or assumption of any synchronisation between the reception of the charging event(s) and the creation of the resulting CDR. However, the CDF shall be capable of receiving and processing charging events and generating the resulting CDR in near real-time.
- The relationship between CDF and CTF may be 1:1 (integrated CDF) or 1:n (separated CDF) (refer to clause 4.5 for possible physical configurations of the logical charging functions). This includes the possibility of NEs of different types feeding charging events into the same CDF.
- All charging events used to build a CDR must originate from the same NE, i.e. there is no cross-NE or cross-NE-type correlation of charging events in the CDF.

The results of the CDF tasks are charging data records (CDRs) with a well-defined content and format. The content and format of these CDRs are specified per domain / subsystem / service in the related middle tier charging specification (e.g. 3GPP TS 32.250 [10] for the CS domain and 3GPP TS 32.251 [11] for the PS domain, etc.).

4.3.1.3 Charging Gateway Function

The CDRs produced by the CDF are transferred immediately to the Charging Gateway Function (CGF) via the Ga reference point. The CGF acts as a gateway between the 3GPP network and the Billing Domain. It uses the Bx reference point for the transfer of CDR files to the BD. The entity relationship between the CDF and the CGF is m:1, i.e. one or more CDFs may feed CDRs into a single CGF. The CGF comprises the following main functions:

- CDR reception from the CDF via the Ga reference point in near real-time. The protocols that may cross the Ga reference point are specified in 3GPP TS 32.295 [54].
- CDR pre-processing:
 - Validation, Consolidation and (Re-) Formatting of CDRs.
 - CDR error handling.
 - Persistent CDR storage.
- CDR routing and filtering, i.e. storing CDRs on separate files based on filtering criteria such as CDR type, CDR parameters, originating CDF, etc.
- CDR File Management, e.g. file creation, file opening / closure triggers, file deletion.
- CDR file transfer to the BD.

For further details of those functions see 3GPP TS 32.297 [52].

4.3.2 Online Charging Functions

Figure 4.3.2 provides an overview of the online part of the common charging architecture. The figure depicts the logical charging functions in the network and the OCS and the reference points between these functions.

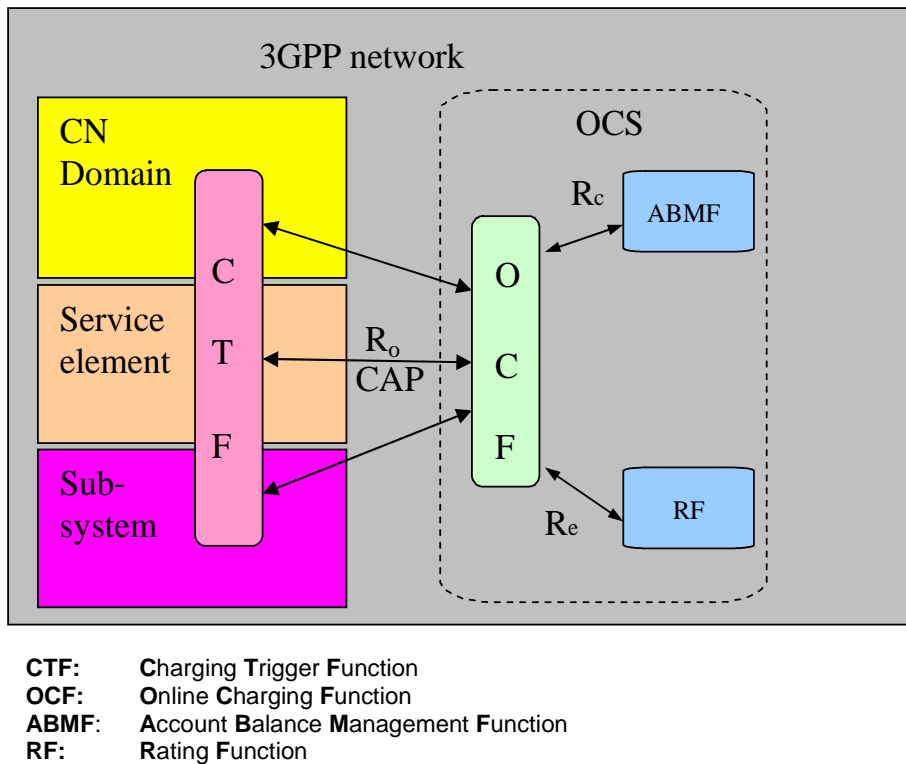

Figure 4.3.2: Logical ubiquitous online charging architecture

4.3.2.1 Charging Trigger Function

As outlined in clause 4.1.2, online charging is a process where charging information is collected in the network element in the same fashion as in offline charging. This implies that, from the functional perspective, the CTF defined in clause 4.3.1.1, also creates the charging events used for online charging. While the accounting metrics used in online charging are generally the same as in offline charging (i.e. the charging mechanism is transparent to the Accounting Metrics Collection), the following functional enhancements concerning the Accounting Data Forwarding are required in the CTF in order to support online charging:

- The information collected for, and included in, the online charging events is not necessarily identical to the offline charging case (i.e. the chargeable events may not necessarily be identical to those observed in offline charging);
- The charging events are forwarded to the Online Charging Function (OCF) in order to obtain authorisation for the chargeable event / network resource usage requested by the user;
- The CTF must be able to delay the actual resource usage until permission by the OCS has been granted;
- The CTF must be able to track the availability of resource usage permission ('quota supervision') during the network resource usage;
- The CTF must be able to enforce termination of the end user's network resource usage when permission by the OCS is not granted or expires.

The underlying principles for requesting, granting and managing resource usage permissions are described in detail in clause 5.1.

Note that the S-CSCF, although involved in online charging, does not create any online charging events, therefore clauses 4.3.2.1 and 4.3.2.2 are not completely applicable to the S-CSCF. Clause 4.3.2.2.2 describes online charging specifically for the S-CSCF.

The charging events for online charging are transferred to the OCS using the CAP or Ro reference points. Refer to figure 4.1 for information on the applicability of CAP or Ro per NE type.

4.3.2.2 Online Charging System

The following subclauses summarise the tasks of the functions comprising the Online Charging System. Details of the OCS, and the role of each of its functional components, are described in 3GPP TS 32.296 [53].

4.3.2.2.1 Online Charging Function

The Online Charging Function (OCF) consists of two distinct modules, namely the Session Based Charging Function (SBCF) and the Event Based Charging Function (EBCF).

The Session Based Charging Function is responsible for online charging of network / user sessions, e.g. voice calls, IP CAN bearers, IP CAN session or IMS sessions.

The Event Based Charging Function performs event-based online charging (also referred to as 'content charging') in conjunction with any application server or service NE, including SIP application servers.

Online charging in the CS and PS domains may be performed using the CAP reference point from the MSC and SGSN, respectively, to the Online Charging Function (refer to 3GPP TS 23.078 [207] for details on CAP). Online charging communication between the S-CSCF and the SBCF is described in clause 4.3.2.2.2. All other network elements employ the Ro reference point for online charging (refer to 3GPP TS 32.299 [50]). Refer to 3GPP TS 32.296 [53] for details on the relation between the network elements (i.e. the embedded online enhanced CTF) and the SBCF or EBCF, respectively.

4.3.2.2.2 S-CSCF online charging / IMS Gateway Function

As stated above, the S-CSCF does not trigger any online charging events and thus does not include the CTF online charging enhancements described in clause 4.3.2.1 (in contrast, it does have a CTF for offline charging, as described in clause 4.3.1.1). Instead, the ISC interface is employed by the S-CSCF online charging, implying that online charging is transparent to the S-CSCF and appears like any other service logic controlled by a SIP application server. Therefore, if support for Ro based online charging is required instead of / or in addition to application server or MRFC, a special CTF is needed in order to mediate between the Ro based SBCF and the SIP based service control. This role is taken by the IMS Gateway Function (IMS GWF), which translates between SIP service control towards the S-CSCF and Ro credit control on the OCS side.

From the perspective of the online charging architecture, the IMS GWF is an online charging capable CTF; from the perspective of the S-CSCF, the IMS GWF is a SIP application server and is triggered the same way. It is out of scope of the 3GPP standards whether the IMS GWF is embedded in the S-CSCF, embedded in the OCS/SBCF, or exists as a stand-alone component.

4.3.2.2.3 Rating Function

The Rating Function (RF) determines the value of the network resource usage (described in the charging event received by the OCF from the network) on behalf of the OCF. To this end, the OCF furnishes the necessary information, obtained from the charging event, to the RF and receives in return the rating output (monetary or non-monetary units), via the Re reference point. The RF may handle a wide variety of rateable instances, such as:

- Rating of data volume (e.g. based on charging initiated by an access network entity, i.e. on the bearer level);
- Rating of session / connection time (e.g. based on charging initiated by a SIP application, i.e. on the subsystem level);
- Rating of service events (e.g. based on charging of web content or MMS, i.e. on the service level).

4.3.2.2.4 Account Balance Management Function

The Account Balance Management Function (ABMF) is the location of the subscriber's account balance within the OCS. The ABMF is not specified in detail in this Release, however, it is put into functional context within 3GPP TS 32.296 [53].

4.3.2.3 CDR generation for online charged subscribers

In offline charging, CDRs are generated in the network and forwarded to the BD for further processing, e.g. generating subscriber bills. In online charging, network resource usage is granted by the OCS based on a subscriber account on the OCS. If required by the operator, CDRs may additionally be generated for online charged subscribers. One way of achieving this is by performing online charging and offline charging simultaneously for these subscribers. Alternatively, the OCS can accomplish this by the use of the appropriate offline charging functions as follows:

- A CDF, as specified in clause 4.3.1.2, is employed by each of the OCFs that are required to generate CDRs from the charging events they receive from the CTF;
- A CGF, as specified in clause 4.3.1.3, is employed by the OCS in order to generate / manage CDR files and provide these files to the BD.

4.4 Reference points

4.4.1 Offline charging reference points

4.4.1.1 Rf

The Rf reference point supports interaction between a Charging Trigger Function and a Charging Data Function. The following information may flow across this reference point in real-time:

- Charging events for offline charging from the CTF to the CDF;
- Acknowledgements for these events from the CDF to the CTF.

The protocol(s) crossing this reference point shall support the following capabilities:

- Real-time transactions;
- Stateless mode ('event based charging') and statefull mode ('session based charging') of operation;
- Provide its own reliability mechanisms, e.g. retransmission of charging events, to run also on unreliable transport.

In addition, the protocol should support changeover to a secondary destination (alternate CDF(s)) in case of the primary CDF not being reachable.

This interface application is defined in 3GPP TS 32.299 [50]. The information contained in the charging events and the relevant chargeable events are specific to the domain / subsystem / service and are detailed in the respective middle tier TSs.

4.4.1.2 Gz

The Gz reference point is functionally equivalent to Ga for Legacy PS domain and to Ga or Rf for Evolved PS domain, and hence is replaced by Ga or Rf within the common charging architecture. See also clause 4.2.

4.4.1.3 Ga

The Ga reference point supports interaction between a Charging Data Function and a Charging Gateway Function. The following information may flow across this reference point:

- CDRs are sent from the CDF to the CGF;
- Acknowledgements for these CDRs are returned from the CGF to the CDF.

The protocol(s) crossing this reference point shall support the following capabilities:

- Near real-time transactions;
- Send one or more CDRs in a single request message;
- Changeover to secondary destinations (alternate CGFs) in case of the primary CGF not being reachable;
- Provide its own reliability mechanisms, e.g. retransmission of charging events, to run also on unreliable transport.

This interface application is defined in 3GPP TS 32.295 [54]. The content of the CDRs, and the CDR trigger conditions, are specific to the domain / subsystem / service and are detailed in the middle tier charging TSs.

4.4.1.4 Bx

The Bx reference point supports interaction between a Charging Gateway Function and the Billing Domain. The information crossing this reference point is comprised of CDR files. A common, standard file transfer protocol (e.g. FTAM, FTP) shall be used, including the transport mechanisms specified for the selected protocol.

This interface application is defined in 3GPP TS 32.297 [52]. The information contained in the files corresponds to the CDRs defined per domain/subsystem/service, as stated in clause 4.4.1.3.

4.4.1.5 Wf

The Wf reference point is functionally equivalent to Rf, and hence is replaced by Rf within the common charging architecture. See also clause 4.2.

4.4.2 Online charging reference points

4.4.2.1 Ro

The Ro reference point supports interaction between a Charging Trigger Function and an Online Charging Function. The following information may flow across this reference point:

- Charging events for online charging from the CTF to the OCF.
- Receive Acknowledgements for these charging events from the OCF to the CTF. The acknowledgement grants or rejects the network resource usage requested in the charging event, according to the decision taken by the OCS.

The protocol(s) crossing this reference point shall support the following capabilities:

- Real-time transactions;
- Stateless mode ('event based charging') and statefull mode ('session based charging') of operation;

NOTE: For "event based charging", the protocol may be stateless, however Internal implementation of the Charging Trigger Function and Online Charging Function may be stateful across the different charging events.

- Provide its own reliability mechanisms, e.g. retransmission of charging events, to run also on unreliable transport.

In addition, the protocol should support changeover to a secondary destination (alternate OCF(s)) in case of the primary OCF not being reachable.

This interface application is defined in 3GPP TS 32.299 [50]. The information contained in the charging events and the relevant chargeable events are specific to the domain / subsystem / service and are detailed in the respective middle tier TSs.

4.4.2.2 CAP

The CAP reference point provides similar functionality for online charging as Ro, however, it is based on CAMEL techniques. It is kept within the overall charging architecture as CAMEL may be used in the CS and PS domains. See 3GPP TS 23.078 [207] for details on CAMEL.

4.4.2.3 Gy

The Gy reference point is functionally equivalent to Ro, and hence is replaced by Ro within the common charging architecture. See also clause 4.2.

4.4.2.4 Re

The Re reference point supports interaction between the OCF and a Rating Function (RF) in order to determine the value of chargeable events in terms of monetary or non-monetary units. This interface application is defined in 3GPP TS 32.296 [53].

4.4.2.5 Rc

The Rc reference point allows the interaction between the OCF and an Account Balance Management Function (ABMF) in order to access the account of the subscriber on the OCS. This reference point is FFS for future releases. See 3GPP TS 32.296 [53] for further information.

4.4.2.6 Wo

The Wo reference point is functionally equivalent to Ro, and hence is replaced by Ro within the common charging architecture. See also clause 4.2.

4.5 Architecture mapping

The following subclauses describe how the logical ubiquitous charging architecture can be mapped onto physical components and interfaces within the scope of 3GPP standards.

4.5.1 Offline mapping

The figures below depict the mappings of the ubiquitous offline charging architecture onto physical implementations that are identified within the 3GPP standards. As stated previously in the present document, the CTF is a mandatory component of all NEs that have offline charging capabilities. In contrast, the CDF and the CGF may be implemented in any of the following ways:

- (1) CDF and CGF integrated in the NE. In this implementation, all network charging functions are embedded in the NE, i.e. the NE is fully self-contained in terms of offline charging. The (physical) NE itself produces the CDR files that are then transferred to the BD. Consequently, only the Bx reference point needs to be implemented as a physical interface.

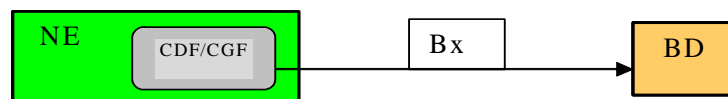

Figure 4.5.1.1 : CDF and CGF integrated in the NE

- (2) CDF integrated in the NE, CGF in a separate physical element. In this implementation, the (physical) NE generates CDRs and sends them to an external CGF. Hence the Ga reference point must be implemented in the NE as a physical interface. If the CGF is a stand-alone entity, it must implement both the Ga and the Bx reference point as physical interface. As a variation of this construct, the CGF may be integrated in the BD, in which case the Bx reference point is internal to the BD.

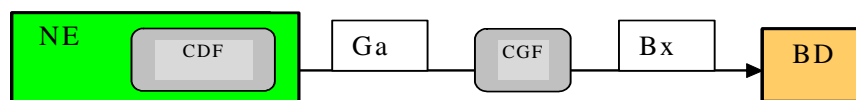

Figure 4.5.1.2 : CDF integrated in the NE, CGF in a separate physical element

- (3) CDF and CGF in two separate physical elements. This scenario represents the fully distributed implementation where all reference points must be implemented as physical interfaces on the NE, CDF and CGF, respectively. Again, as a variation of this approach, the CGF may be an integral component of the BD, in which case the Bx reference point becomes internal to the BD.

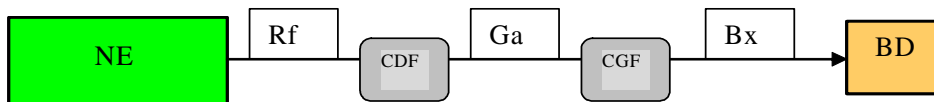

Figure 4.5.1.3 : CDF and CGF in two separate physical elements

- (4) CDF and CGF in the same separate physical element. In contrast to scenario 3, there is no physical Ga interface, whereas the Rf and Bx reference points must exist as distinct interfaces in the same fashion as in scenario 3. The variation of the combined CDF/CGF being embedded in the BD is again possible, resulting in the Rf reference point being the only one that appears as a physical interface.

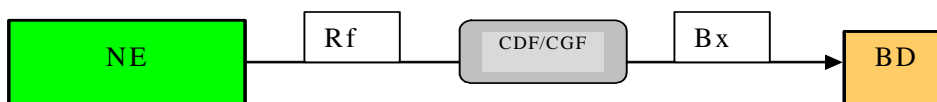

Figure 4.5.1.4 : CDF and CGF in the same separate physical element

Details of the possible implementation options per domain / subsystem / service (usually a subset of the overall possible variants described above) are specified in the respective middle tier TS.

4.5.2 Online mapping

The CTF is a mandatory integrated component of all network elements that are involved in online charging as depicted in figure 4.1, with the exception of the S-CSCF (see clause 4.3.2.2.2). If CDR generation by the OCS is required, as described in clause 4.3.2.3, then a CDF is integrated in each OCF that is required to produce the CDRs. All other possibilities for physical mapping, including e.g.:

- integrated versus distributed CGF in the OCS,
- use of another CGF by the OCS,
- IMS GWF integrated in S-CSCF or OCS, or a stand-alone entity,

are not specified within the 3GPP standards and are therefore implementation specific. The same is true for the composition of the OCS and its logical functions.

5 Charging principles

The high-level requirements for charging are specified in 3GPP TS 22.115 [101]. The following subclauses detail the charging principles on the basis of the architecture and framework defined in clause 4, in respect of:

- Charging data generation and quota supervision;
- Aspects of charging information transfer;
- Charging levels and charging data correlation;
- Charging information utilisation.

5.1 Charging data generation and quota supervision

The CTF embedded in all charging relevant network elements collects charging information within the NE concerning the use of network resources by the mobile end users. These network resources may pertain to bearer (e.g. CS, PS, WLAN), subsystem (e.g. IMS sessions) or service (e.g. MMS) usage / consumption. The various charging levels are further described in clause 5.3.

The purpose of offline charging is to transform the charging information into CDRs that are post-processed within the Billing Domain, e.g. for the purpose of generating bills. While the collection of charging information used for the CDRs occurs during the network resource usage, there is no impact of offline charging on the use of the resources. All activities involved in the transformation of the charging information into end user bills, and the collection of the end user charges incurred in these bills, occur *offline* to, or after, the network resource usage.

The purpose of online charging is to furnish charging information to the OCS in order to perform credit control before the network resource usage is permitted. To this end, a prepaid subscriber account has to exist in the OCS, against which the resource usage can be billed. Hence all activities to assess the requested resource usage, to determine its value in monetary or other units, and to debit these units from the subscriber account, must occur prior to or at least, during the resource usage, i.e. *online* with respect to resource usage. Depending on the circumstances, a final evaluation must occur when resource usage ends. Hence, two cases must be distinguished:

- **Direct Debiting:** the requested resource can be determined and billed in a one-off procedure. In that case, the resource usage is debited from the subscriber account immediately when processing the charging event, and the permission for the resource usage is returned to the network. An example of this may be the forwarding of a terminating short message from the MSC to the end user. In this scenario, it is generally required that the network can guarantee resource usage execution in order to avoid over-billing the user.
- **Unit Reservation:** the OCS cannot a priori know the amount of resources that the end user may eventually consume, or it cannot be assumed a priori that the resource usage request can be (completely) fulfilled. In this case, a certain amount of (monetary or non-monetary) units is blocked, or reserved, on the subscriber's account on the OCS, and permission to use an amount of resources that matches the unit reservation is returned to the network. When the granted units have been used or a new, not yet authorised chargeable event occurs, the network must send a new request for unit allocation to the OCS. When resource usage has been executed, the actual amount of resource usage (i.e. the used units) must be returned by the NE to the OCS so that eventually over-reserved amounts can be re-credited to the subscriber account, assuring that the correct amount gets debited.

Charging information is collected by the CTF based on chargeable events that describe the user(s) and their requested network resource usage. The chargeable events are specific to each domain / service / subsystem and specified in the respective middle tier charging TS. For each chargeable event, a matching charging event is formed and immediately sent to its destination, i.e. the CDF in offline charging or the OCF in online charging. Again, the event information is specific to the domain / service / subsystem and defined in the respective middle tier charging TS. While the accounting metrics (provided by the Accounting Metrics Collection part of the CTF) used in online and offline charging are generally identical, the information comprising chargeable events (determined by the Accounting Data Forwarding part of the CTF) may be different between online and offline charging. Note also that online and offline charging may occur simultaneously, i.e. for the same resource usage the CTF may send an offline charging event to the CDF and an online charging event to the OCF. In that particular case, credit control occurs for that resource usage but at the same time,

CDRs are created in offline charging. Alternatively, if CDRs are required for online charged resource usage, this can be achieved by generating these CDRs in the OCS, as depicted in clause 4.3.2.3.

Both online and offline charging can be categorised into two distinct classes, namely event based charging and session based charging. Event based charging implies that a chargeable event is defined as a single end-user-to-network transaction, e.g. the sending of a multimedia message. This chargeable event is then mapped to an appropriate charging event, resulting in a single CDR or in a single credit control and resource usage authorisation procedure. In contrast, session based charging is characterised by the existence of a user session, such as a circuit call, an IP CAN bearer, or an IMS session. This user session is then matched by a charging session, resulting in the generation of multiple chargeable/charging events and the creation of one or more CDRs in offline charging or the performance of a credit control session in online charging. The following paragraphs describe the event versus session based charging in more detail for both online and offline charging.

- **Event based charging.** The (chargeable) event is recognised in the NE that handles it, based on e.g. signalling exchange between the user equipment and the NE. The event is then mapped onto a single charging event as specified in the middle tier charging TS that applies to that NE.
 - In *online* charging, the charging event is transferred to the EBCF via the Ro or CAP reference point, and the chargeable event is authorised after successfully performing credit control on the subscriber account. The complete procedure must occur in real-time. If the chargeable event is not authorised by the OCS (e.g. when the subscriber account does not contain sufficient credit), the NE rejects the resource usage pertaining to that chargeable event.
 - The event charging procedure may occur with or without reservation of units from the subscriber's account ('Event Charging with Unit Reservation' (ECUR) or 'Immediate Event Charging' (IEC), respectively), as described above. Furthermore, if the procedure does include reservation, the OCS may choose to authorise one or more occurrences of the chargeable event (i.e. allot one or more 'service' units). For example, multiple short messages may be authorised upon the first SMS request from the user.
 - In *offline* charging, the charging event is transferred to the CDF via the Rf reference point. The CDF produces a matching CDR, which is then sent to the CGF via the Ga reference point. The CDR will eventually be transferred to the BD in a CDR file, together with other CDRs of the same or different types, according to file transfer configuration by the operator. While there is no real-time requirement on any particular part of this procedure, the system should be capable of completing the process from the detection of the chargeable event up to, and including, CDR transfer to the CGF, in near real-time.
- **Session based charging.** The start of the user session is recognised by the NE that handles the session, based on e.g. signalling exchange between the user equipment and the NE. This chargeable event is then mapped onto a charging event as specified in the middle tier charging TS that applies to that NE.
 - In *online* charging, an 'initial' charging event (session start) is transferred to the SBCF via the Ro or CAP reference point and the start of the user session is authorised after successfully performing credit control on the subscriber account. The NE may delay the actual start of the user session until authorisation has been obtained (cf. 4.3.2.1). As there is no information available at this time concerning the overall evaluation of the session (e.g. complete duration or data volume of the session), session based charging always involves reservation of units from the subscriber's account ('Session based Charging with Unit Reservation' (SCUR)): the OCS reserves credit from the subscriber account and returns the corresponding quota (e.g. units specifying the number of minutes or bytes allowed) to the NE. The NE, in turn, uses the provided quota to supervise the actual network resource consumption. In the case that another chargeable event occurs for the session, the network element issues an 'interim' charging event in order to also authorise this new chargeable event. When the quota is used up, the network element either issues another interim charging event, requesting further units to be allotted, or terminates the session if previously instructed to do so by the OCS. Once the session is terminated in the network element, the consumed units are reported back to the OCS with a 'final' charging event. The credit control session is then terminated, and the OCS returns the value of any unused quota (as reported by the NE) to the subscriber's account. The complete procedure of receiving, processing and responding to an online charging event, must occur in real-time. Note that this procedure can occur in parallel for several concurrent services running on the same user session.

For each charging event received during the session, the OCS decides whether to authorise the resource usage or whether to decline the request (e.g. when the subscriber account does not contain sufficient credit). If, at any time within the session, the OCS determines not to authorise the chargeable event, it rejects the request sent by the network element, causing the NE to disallow the resource usage pertaining to that

chargeable event. It must be noted that this does not necessarily terminate the user session. E.g. in the case of credit exhaustion, the session could be redirected to a credit recharging site.

- In *offline* charging, the 'initial' charging event is transferred to the CDF via the Rf reference point. Upon termination of the subscriber session, or when a new chargeable event occurs (as specified in the respective middle tier charging TS), further charging events ('final' or 'interim' events, respectively) are sent for the session from the NE to the CDF. The CDF formats one or more of these events into CDRs according to CDR formats specified in the middle tier TSs, and in accordance with CDR generation triggers configured by the operator. Upon its completion, the CDR will be sent forward to the CGF via the Ga reference point, and a new CDR will be opened by the CDF for the same session. Finally, the CDRs will eventually be transferred to the BD in a CDR file, together with other CDRs of the same or different types, according to file transfer configuration by the operator.

The system should be capable of completing the process of chargeable event detection and charging event forwarding, CDR generation / closure and CDR forwarding as closely as possible in real-time. However, a significant time may pass between the reception of the first charging event for a CDR and the time the CDR is closed, depending on the CDR generation triggers configured by the operator.

For both event and session based charging, it has been specified above that the NE shall disallow the requested resource usage when the associated chargeable event is not authorised by the OCS. The most typical case for the OCS to refuse authorisation is the expiry of the subscriber account. However, depending on operator policy, even in the case of account expiry the OCS may determine to allow the resource usage to occur / to continue. For example, if the interruption of the user session renders the complete session useless to the end user, it would be unfair to debit the user's account for the portion of the session that was executed. While the decision making procedures and the special treatment of this situation are internal to the OCS, the important aspect to note is that the OCS *must grant authorisation* towards the network in order to allow the event to occur or the session to continue, effectively making the event or (remainder of the) session free of charge.

Clause 5.2 provides a detailed analysis of the possible relationships between charging events, credit control processes, CDRs and CDR files as well as their triggers.

Both Charging Data Record and online charging data generation and contents should be flexible and unnecessary redundancy in data should be avoided. Clause 5.4 describes how the generation of charging data can be configured by the network operator in order to support the above requirement.

Charging data are collected for successful and selected unsuccessful resource usage attempts. The resource usage attempt is seen as being successful in the network element (where the chargeable event is detected) when the user event is successfully completed, or the user session has started. Further details, such as the indication of failure and failure reasons in charging events and CDRs, are specified in the middle tier charging TSs.

NOTE: Some of the terminology used in this clause differs from IETF RFC 4006 [402] that forms the basis for the online charging application. For example, the DCCA uses 'session' and 'event' more in terms of the credit control protocol rather than in terms of user activity, as the present document does. The mapping of the concepts and terminology used to describe the concepts, is described in 3GPP TS 32.299 [50].

5.2 Charging data transfer

Clause 5.1 describes the generation of charging information, events and records and quota supervision across the various logical functions. In the present clause, the relation between the events, records, credit control sessions and CDR files is explained.

5.2.1 Charging data transfer in offline charging

In offline charging, charging events mirroring the resource usage request of the user are transferred from the CTF to the CDF via the Rf reference point. The CTF determines whether the request corresponds to an event (event based charging) or whether a session shall be started (session based charging). Generally, this property is built into the network capability, or service, that the NE provides, and described in the middle tier charging TSs.

5.2.1.1 Transfer of charging events via Rf

In event based charging, a network / user event (e.g. MM submission) corresponds to a single chargeable event. In session based charging, at least two chargeable events are needed, one each to describe the start and the end of the session, respectively. Multiple interim events are possible in order to describe changes to session characteristics (generally termed 'change of charging condition', e.g. tariff time switch, change of PDP context QoS or change of IMS session media types), or when certain limits, e.g. time or volume, are exceeded. The CTF transforms each chargeable event into a charging event and forwards these charging events to the CDF in real-time.

The relation between chargeable events and charging events is 1:1. For event based charging, the relation between charging events and CDRs is 1:1. For session based charging, the relation between charging events and CDRs is m:n with $m \geq n$. The middle tier TSs specify the chargeable events per domain / service / subsystem even if Rf does not exist as an open interface in the respective domain / service / subsystem, as it is always required to identify the connection between chargeable events and triggers for CDR generation and information addition.

If charging events are generated for unsuccessful resource usage attempts, the charging event must describe the reason and the circumstances of the failure. Details, including if and when those events are generated, are specified in the middle tier TSs.

Details on the protocol application for the open Rf interface, including the message types and the domain / subsystem /service independent contents of the messages, can be found in 3GPP TS 32.299 [50].

5.2.1.2 Transfer of CDRs via Ga

Upon receiving a charging event, the CDF uses the event to create/open a CDR (both event and session based charging), or to add information to an existing open CDR. As there is a 1:1 mapping between charging events and CDRs in event based charging, CDRs are created promptly after receiving and processing the event, and are then ready for transfer on to the CGF via the Ga reference point.

In session based charging, a CDR is opened when the initial charging event, specifying the start of a user session, is received. Information is added to the CDR upon receiving interim charging events. The CDR may be closed due to a number of reasons configured on the CDF or dependent on implementation, including but not limited to:

- CDR time limit;
- CDR volume limit;
- limit of change of charging conditions;
- end of user session, e.g. reception of the final charging event describing the session termination;
- limits (e.g. memory size) imposed by implementation.

When a CDR is closed and the session is still active, a subsequent CDR is opened. Hence multiple 'partial CDRs' may be needed to completely describe the session. This implies that opening and closure of CDRs may occur completely asynchronously to the reception of the charging events.

The size of partial CDRs could be optionally reduced by allowing a reduced format for partial CDRs, implying that some information can be eliminated rather than repeated in all the partial CDRs. This means that only changes from one CDR to the next, in addition to mandatory information, is reported. All the missing information can be reconstructed from fields in previous partial CDRs. For example, if location information is captured in CDRs but the user did not change location, the corresponding partial CDR would not include any location information.

Therefore, two formats are considered for Partial CDRs:

- a *Fully Qualified Partial CDR* that contains the complete set of CDR Fields, and
- a *Reduced Partial CDR* that contains all the Mandatory fields (**M**) and ONLY the changes that occurred in any other field relative to the previous partial CDR.

The first CDR generated when a session is opened shall be a Fully Qualified Partial CDR. Subsequent partial CDRs may be Reduced Partial CDRs. Thus, the convention is that when any non-mandatory field is missing from a Reduced Partial CDR, it should be interpreted that the same field as in the previous partial CDR could be used. Refer to clause 5.4 for the definition of 'mandatory' and other CDR field categories.

All CDFs and CGFs from all vendors shall be able to generate or receive Fully Qualified Partial CDRs. Generation and reception of Reduced Partial CDRs on the Ga interface is optional. However, if Reduced Partial CDRs are transmitted on the Ga interface they must comply with the rules specified in this clause.

If the CDFs are generating Reduced Partial CDRs on the Ga interface, the CGF must be able to convert the CDRs into Fully Qualified Partial CDRs. However, if according to operator choice, the BD can support Reduced Partial CDRs, no conversion to the Fully Qualified Partial CDR format is required.

The possible charging configurations that can be supported on both the Ga and the Bx interfaces are illustrated in figure 5.2.1.2. Configuration a) is the default arrangement that MUST be supported by all systems. The other configurations are optional and may be supported IN ADDITION to configuration a). Configuration b) illustrates the case where the CGF is converting Reduced to Fully Qualified Partial CDRs. Configuration c) depicts the case where Reduced Partial CDRs can be received in the billing domain and no conversion is needed.

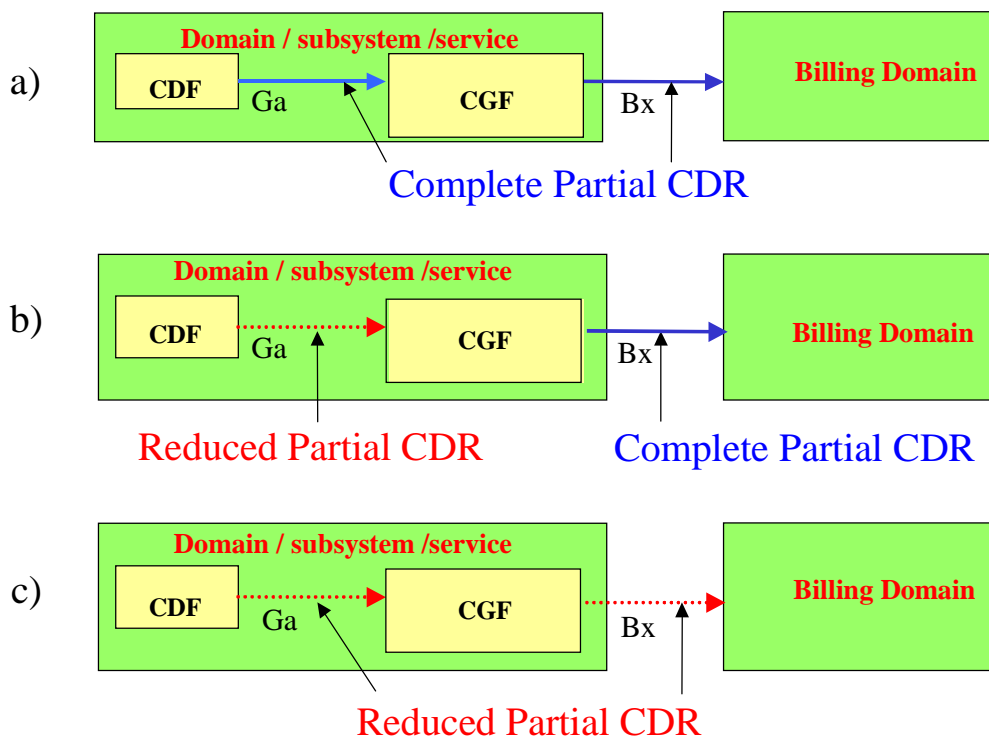

Figure 5.2.1.2 : Possible Configurations of Ga and Bx CDR Formats

When a CDR is closed, it is immediately transferred to the CGF. The exact timing may be determined by configuration parameters of the protocol used on Ga. The CDF shall be capable of receiving and processing charging events and generating and forwarding the resulting CDRs in near real-time.

Details on the protocol application for the open Ga interface can be found in 3GPP TS 32.295 [54]. The semantics and formal description of the CDR parameters are specified in 3GPP TS 32.298 [51].

5.2.1.3 Transfer of CDR files via Bx

The CGF is responsible for persistent CDR storage, for preparing CDR files and transferring them to the BD via the Bx reference point. To this end, the CGF provides one or more files on which to store the CDRs after potential reformatting to comply with the Bx file format specified in 3GPP TS 32.297 [52].

The CDRs may be routed to one of several simultaneously open files inside the CGF depending on certain CDR parameters, such as CDR type, or on other criteria such as the originating CDF. CDR files are closed on the CGF based on certain operator configured parameters, for example:

- file size limit,

- file duration (time) limit,
- time of day,
- maximum number of CDRs.

This implies that the closure of a CDR file occurs asynchronously to the reception of CDRs on the CGF. When a CDR file is closed, the CGF must assure that a new CDR file is available to store incoming CDRs in line with the CDR routing facility described above.

Once CDR files are closed, they are ready for transfer to the BD. The CGF shall support both 'push' transfer mode (i.e. CGF triggers and controls file transfer to BD) and 'pull' transfer mode (i.e. BD triggers and controls file transfer). In push mode, the CGF uploads the files to the BD according to operator specified parameters, such as time of day, number of available files, etc. In pull mode, the BD may request the files from the CGF at any point in time at the discretion of the BD.

For all procedures involved in CDR reception, processing and storing, the CGF shall be capable of complying with near real-time requirements. Details on the protocol application for the open Bx interface and the functionality of the CGF can be found in 3GPP TS 32.297 [52]. The semantics and formal description of the CDR parameters are specified in 3GPP TS 32.298 [51].

5.2.2 Charging Data Transfer in Online Charging

In online charging, charging events mirroring the resource usage request of the user are transferred from the CTF to the OCF via the Ro reference point. The CTF determines whether the request corresponds to an user / network event (event based charging, e.g. MMS) or whether a session shall be started (session based charging, e.g. IP CAN bearer). Generally, this property is built into the network capability, or service, that the NE provides, and described in the middle tier charging TSs.

Note that 3GPP TS 23.078 [207] also specifies online charging capability in the SGSN and MSC based on CAMEL, i.e. using the CAP reference point towards the OCS. This functionality is outside the scope of the present document.

In event based charging, a network / user event (e.g. MM submission) corresponds to a single chargeable event. In session based charging, at least two chargeable events are needed, one each to describe the start and the end of the session, respectively. Multiple interim events are possible in order to describe changes of session characteristics (e.g. change of IP CAN bearer QoS or change of IMS session media types), or when certain limits, e.g. time or volume, are exceeded. The CTF transforms each chargeable event into a charging event and forwards these charging events to the OCF in real-time.

For event based charging, the credit control procedure in the OCS may or may not involve reservation of units from the subscriber account, as described in clause 5.1. In the case of event based charging without reservation (IEC):

- The CTF forwards the charging event to the OCS;
- The OCS determines the value of the requested resource usage and debits this value from the subscriber account;
- The OCS returns the resource usage authorisation to the network element;
- The network element executes the resource usage according to the user request and the OCS authorisation.

The following exceptions and abnormal cases are defined for the IEC scenario:

- 1) The OCS rejects the resource usage request. In this case, the NE disallows the resource usage.
- 2) Subsequent to resource usage authorisation and execution of the resource usage, the resource usage fails and the CTF may return the failure to the OCS to initiate a refund for the original resource usage.

NOTE 1: The triggering of the refund action is implementation and service dependent.

If the credit control procedure does involve reservation (ECUR):

- The CTF forwards the charging event to the OCS;
- The OCS determines the value of the requested resource usage and reserves this value from the subscriber account;

- The OCS returns the resource usage authorisation to the network element;
- The network element executes the resource usage according to the user request and the OCS authorisation.
- After completion (or failure) of the resource usage, the NE informs the OCS accordingly about the completion or failure;
- In line with the result report from the network element, the OCS either debits the reserved amount from the subscriber account (success), or it returns the reserved amount back to the subscriber account (failure).

The following exceptions and abnormal cases are defined for the ECUR scenario:

- 1) The OCS rejects the resource usage request. In this case, the NE disallows the resource usage.
- 2) The resource usage execution fails, e.g. due to network failure or user abort. In this case, the network element informs the OCS of the failure, and the previously reserved amounts are returned onto the subscriber account.

NOTE 2: Returning previously reserved amounts of units to the user's account is up to operator policy in the OCS. The authorization of multiple chargeable events as per the 'event based charging' description in clause 5.1 is not yet covered in the above scenario.

Session based online charging always involves reservation within the credit control procedure (SCUR), as there is no way for the OCS to predict the amount of resource usage that occurs during the user session. To begin with, the CTF forward generates a charging chargeable event that corresponds to the resource usage request and maps onto the user session, and forwards it to the OCF. In the OCS, the online charging session is started and a certain amount reserved from the user subscriber account. This amount is determined by the OCS based on the information in the charging event and on local configuration, i.e. operator policy. A resource usage quota, matching the reserved amount, is then returned by the OCS, at which point the user session starts in the NE. Further charging events are sent from the NE to the OCS upon the detection of further chargeable events within the session .e.g. the expiry of in intervals configured on the NE or instructed by the OCS, or when the authorised quota expires, or when session characteristics change (e.g. change of QoS of an IP CAN bearer). The OCS then furnishes a new quota to the NE as required, or rejects the charging event, e.g. due to expiry of credit on the subscriber account. The OCS also furnishes the NE's behaviour on quota expiry (termination action). When the user session terminates normally in the NE, a final statement on the actually used network resources is returned to the OCS, enabling the OCS to calculate the final value of the actual resource usage session and to properly debit the corresponding final amount from the subscriber account (possibly resulting in a re-crediting of previously reserved amounts). This also terminates the credit control session for the particular user session. The following exceptions and abnormal cases are defined for the SCUR scenario:

- 1) For optimisation purposes, the network element may allow the user session to start prior to receiving the initial authorisation from the OCS, i.e. prior to the start of the credit control session.
- 2) The OCS rejects the initial resource usage request at session start, i.e. no credit control session is started. In this case, the NE disallows the start of the session or, if the session was already allowed to start as described in item 1 above, enforces the termination of the user session.
- 3) The OCS rejects the resource usage request in mid session. In this case, the NE's behaviour conforms to the instruction returned by the OCS, e.g.:
 - terminate the user session;
 - limit the characteristics of the user session, e.g. allow only Web/WAP pages that are free of charge;
 - direct the session to a special notification site or an account recharging server
- 4) The OCS may send unsolicited termination commands with the same effect as described in item 3 above.
- 5) Unexpected termination of user session, e.g. due to network failure or due to user abort. In this case, the behaviour of the network is as specified above for session termination, but all available information of the failure is returned to the OCS in the final statement. Further action of the OCS in regard of calculating the session value and debiting or crediting the user's account depends on the exact circumstances and operator policy.

In any of the above cases, the termination of the user session coincides with the termination of the credit control session, e.g. even when a user session is allowed to continue upon account expiry, the credit control session will also continue, but 'zero' rated.

NOTE 3: the intention of the above clause is not to enforce closing the user session when the credit control session breaks down.

It is important for operators to carefully consider the reservation policy on the OCS. On the one hand, if small amounts are reserved, the NE must renew the authorisation very frequently, creating high signalling and processing loads. Additionally, this policy has a comparatively high likelihood of longer, or higher-value, user sessions being forcefully terminated due to expiry of the subscriber account after many small quotas have been used for small chunks of the subscriber session. In contrast, assigning high reservations avoids the above problems, but may interdict the user from the execution of additional, parallel resource usages: due to the high previous reservation, there is no credit left on the account for another resource usage request. The situation described in this paragraph is particularly complex when correlation between multiple charging levels is necessary, see clause 5.3.4. A potential method of relieving this problem is the pooling of credit quotas as described in clause 5.5.2 below.

The middle tier charging TSs specify the chargeable events and the content of the associated charging events and responses. 3GPP TS 32.299 [50] specifies the interface application for the Ro reference point, including the message types and the domain / subsystem / service independent contents of the messages. In addition to the credit control functions, the OCS may also be capable of producing CDRs based on the execution of the above credit control procedures. To this end, the OCS must implement a CDF, and it uses the Ga and Bo reference points to forward its CDRs to a CGF and the CDR files to the BD. These functions of the OCS, however, are outside the scope of 3GPP standardisation.

5.3 Charging levels and correlation

Editor's note: To be completed. The use of EBCF and SBCF in the subclauses for all the three charging levels shall also be described here.

5.3.1 Bearer level charging

5.3.1.1 Bearer charging based on bearer / tele- / supplementary service

Editor's note: To be completed.

Charging data are also collected for supplementary service activity.

5.3.1.2 Flow based bearer charging

Editor's note: To be completed.

5.3.2 Subsystem level charging

Editor's note: To be completed.

5.3.3 Service level charging

Editor's note: To be completed.

5.3.4 Charging data correlation

The charging data correlation combines charging events generated by CTF while they are belong to the same bearer / session / service resource usage. The correlation provides an association of charging information for the mobile subscriber's resource usage.

The correlation is based on specific access network charging identifier:

- Circuit Switched domain: MSC address and Call Reference Number;
- Packet Switched domain: P-GW address and EPC Charging ID;
- WLAN Access: PDG address and WLAN Charging ID;

- Fixed Broadband Access: Multimedia Charging ID;
- IM Subsystem: IMS Charging Identifier.

The charging information has to be aggregate for the same charging session and correlate for the same service.

5.3.4.1 Intra-level correlation

The intra-level correlation aggregates the charging events belonging to the same charging session, e.g. over a time period, and implies the generation of interim charging records.

5.3.4.2 Inter-level correlation

The inter-level correlation combines the charging events belonging to the same service but generated by different CTFs e.g. for PS access control via IM Subsystem.

5.3.4.3 Inter-network correlation

To enable the different operators involved in IMS sessions to identify each other, the Inter Operator Identification concept (IOI) is introduced. IOI allows operators involved with session signalling to identify each other by exchanging operator identification information within the SIP signalling. The IOI is composed of one pair of originating IOI and terminating IOI. The IOI concept may help to support inter operator charging.

The following requirements relate to the IOI concept:

- a) The IOI concept shall allow operators to uniquely identify each other for the SIP based requests; for example between A's HPLMN and B's HPLMN or between an A's HPLMN and a A's VPLMN
- b) The IOI concept can be used for inter operator accounting identification purposes.
- c) It shall be possible to prevent the information used for IOI from being passed to the UE.
- d) It shall be possible to apply the IOI concept on a peer to peer basis between operators. It shall be possible to use different identity values for operator identification between operators involved in IMS session related procedures and session unrelated procedures.
- e) IOI identities shall be included within SIP signalling:
 - 1) When a SIP request is passed out of a network the IOI identity of that network (referred as originating IOI) shall be included in the SIP signalling.
 - 2) When a SIP response is returned the IOI identity of that responding network (referred as terminating IOI) shall be included in the SIP signalling.
- f) Each network is responsible for including its own unique IOI Identity into the SIP signalling. The IOI Identity shall be unique for each operator (for example the IOI Identity of Home Operator A is different from Home Operator B).
- g) Three types of IOI shall be defined:
- h) Type 1 IOI: between the home network operator and a visited network operator for an end user in roaming situation (case when the P-CSCF is located in a visited network);
- i) Type 2 IOI: between the network operator which holds the subscription of the originating end user and the network operator which holds the subscription of the terminating end user. In case of redirection, Type 2 IOI can be used between network operators which hold a subscription of the terminating end user, i.e. between the terminating party's network operator from which the session is redirected to the terminating party's network operator to which the session is redirected.
- j) Type 3 IOI: between the home network operator and a service provider;
- k) For Type 1 IOI, the P-CSCF in the VPLMN is responsible for generating the originating IOI and the S-CSCF in the home network is responsible for generating the terminating IOI;

- l) For Type 2 IOI, the S-CSCF in the originating party's home network or the originating MGCF is responsible for generating the originating IOI and the S-CSCF in the terminating party's home network or the terminating MGCF is responsible for generating the terminating IOI. In case of redirection by the S-CSCF, the S-CSCF-in the terminating party's network operator from which the session is redirected- is responsible for generating the originating IOI and the S-CSCF in the terminating party's network operator or the terminating MGCF- to which the session is redirected- is responsible for generating the terminating IOI.
- m) For Type 3 IOI, when forwarding a request to an AS, the S-CSCF in the home network is responsible for generating the originating IOI and the AS contacted by this S-CSCF is responsible for generating the terminating IOI. For a Type 3 IOI, when an AS initiates a request, the AS is responsible for generating the originating IOI and the S-CSCF or I-CSCF contacted by this AS is responsible for generating the terminating IOI.
- n) IOI Identities received in the session signalling shall be incorporated into the CDRs produced by the IMS network elements. The operator identification information may be used for inter operator accounting purposes.
- o) The allocation of the IOI values for the operators is outside the scope of 3GPP standardization.

NOTE: The relationship of the IOI concept with security aspects between operators is For Further Study (FFS).

5.4 Charging data configuration

Charging interface applications are specified for Rf and Ro in 3GPP TS 32.299 [50], for Ga in 3GPP TS 32.295 [54], and for Bx in 3GPP TS 32.297 [52]. The middle tier charging TSs determine per domain / service / subsystem which of the reference points exist as open interfaces and which of them are internal to integrated NEs (see charging architecture mapping discussion in clause 4.5). In accordance with these prerequisites, the content of charging events and CDRs is also specified in the middle tier charging TSs on all the open network interfaces that exist in the respective domain / subsystem / service. The rules governing the presence of charging event or CDR parameters on these interfaces are summarized in this clause. A logical diagram illustrating the possible presence requirements for charging event / CDR parameters ('field categories') is shown in Figure 5.4.

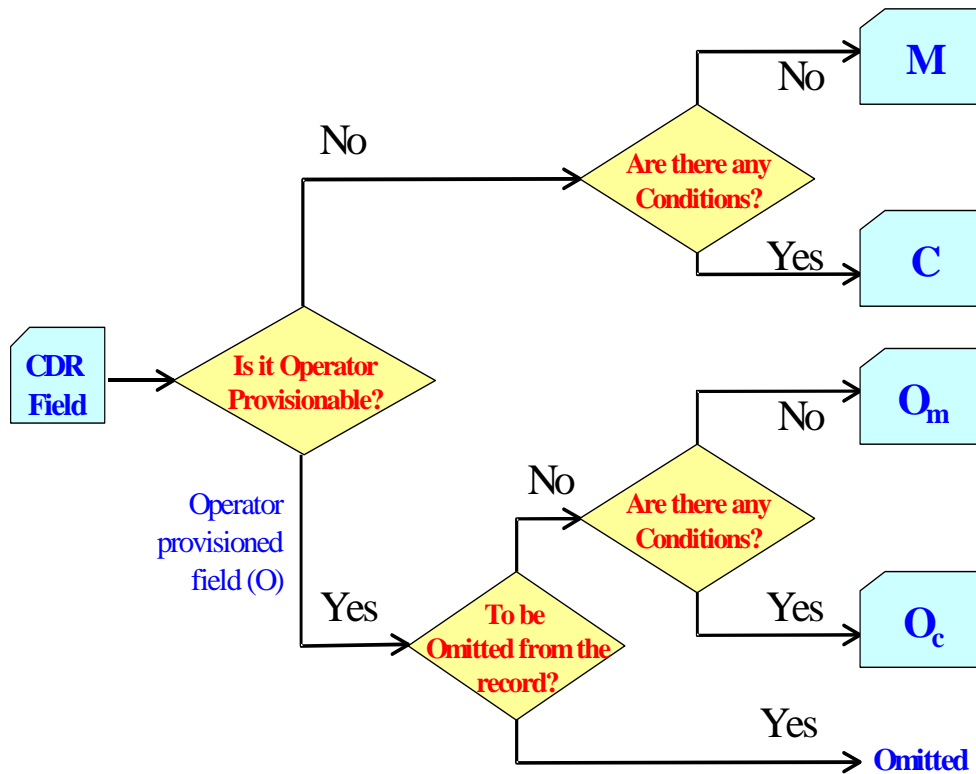

Figure 5.4 : Logical diagram illustrating the different CDR field categories

The charging event and CDR description tables in the middle tier charging TSs specify the Mandatory (M), Conditional (C) and Operator provisionable (O_c or O_m) designations. The category of a charging event or CDR parameter can have one of two primary values:

M This parameter is **Mandatory** and shall always be present in the event / CDR.

C This parameter shall be present in the event / CDR only when certain **Conditions** are met. These **Conditions** are specified as part of the parameter definition.

All other parameters are designated as **Operator provisionable (O)**. Using network management functions or specific tools provided by an equipment vendor, operators may choose if they wish to include or omit the parameter from the charging event / CDR. Once omitted, this parameter is not generated in an event / a CDR. To avoid any potential ambiguity, the CTF / CDF / CGF **MUST** be able to provide all these parameters. Only an operator can choose whether or not these parameters should be generated in their system, i.e. included in the charging event / CDR.

Those parameters that the operator configures to be present are further divided into mandatory and conditional categories:

O_m This is a parameter that, if provisioned by the operator to be present, shall always be included in the events / CDRs. In other words, an O_m parameter that is provisioned to be present is a mandatory parameter.

O_c This is a parameter that, if provisioned by the operator to be present, shall be included in the events / CDRs when the specified conditions are met. In other words, an O_c parameter that is configured to be present is a conditional parameter.

The charging event and CDR tables provide a brief description of each event / CDR parameter in the corresponding "middle 'tier' TSs. The full definitions of the parameters, sorted by the parameter name in alphabetical order, are provided in 3GPP TS 32.298 [51].

5.5 Charging information utilisation

To be completed. This clause should be separated between offline charging / CDRs / billing and online charging / credit control. OCS aspects will also be included (e.g. OCS CDRs), e.g. the following text: 'It is important to note that also in the online charging case, operators may wish to apply similar billing analyses (e.g. statistics) and, obviously, inter-operator accounting, as in the offline charging case. If this is required, the OCS is responsible to generate CDRs similar in scope to the ones described in offline charging above.'

The MSC server and Gateway MSC server are responsible for the collection of all charging relevant information for each MS and PSTN connection and for the storage of this information in the form of CDRs.

Circuit switched calls can be charged in one MSC server (the anchor MSC server) where all relevant data is available. That is guaranteed by routing all signalling information through the anchor MSC server even if the traffic channel of a call is routed through another MSC server due to handover.

The Gateway MSC server acts as a gateway into other PLMN or fixed networks. Within the PLMN, the GMSC server is responsible for the generation of CDRs for calls routed from or into other networks.

If subscribed CAMEL services apply to MS, the (G)MSC servers contain CAMEL subscription data providing the information required for invocation of the CAMEL dialogues for controlling the MS terminating and MS originating calls. Charging data record parameters resulting from the CAMEL treatment applying to MS calls is derived from the CAMEL subscription data.

In addition to user subscribed services, specific dialled CAMEL services might be invoked which also influence existing records or even trigger the generation of separate records steered by service logic.

In addition to the information collected from these network elements, network management functions are required for the administration of on-line charging data stored in the network nodes. This data is employed to drive the charge display on the User Equipment (UE) as required by the Advice of Charge (AoC) service in TS 21.115 [101] and charging perspective of AoC is defined by 3GPP TS 32.280 [69].

5.5.1 Subscriber charging

The charging data collected from the HPLMN, interrogating PLMN, and/or VPLMN network elements is employed to determine the network utilization charges for the basic and supplementary services utilized by the home subscribers of the PLMN. The charges calculated are then combined with the network access (subscription) charges and billed to those customers directly serviced by the PLMN.

For those subscribers handled by Service Providers, the billing information is employed for both wholesale (Network Operator to Service Provider) and retail (Service Provider to Subscriber) billing. Consequently, having been processed by the PLMN Billing System, the charging data collected from the network elements may also be sent to the Service Provider for further processing.

5.5.1.1 Calling Party Charging

This applies to calling party pays in Charged Party principals defined in 3GPP TS 22.115 [101].

For subscription related chargeable events the charging information shall indicate the charged party is normally the calling party. It should be possible for multiple leg calls (e.g. forwarded, conference or roamed) to be charged to each party as if each leg was separately initiated. However, in certain types of call, the originating party may wish/be obliged to pay for other legs (e.g. SMS MO may also pay for the MT leg.).

It shall be possible to change the chargeable party at the call set-up.

5.5.1.2 Alternate Party Charging for IMS

This applies to the alternate charged party in Charged Party principles defined in 3GPP TS 22.115 [101].

In IMS Offline and Online Charging as an alternative it is possible that neither calling nor called party can be charged for the IMS session. The alternate charged party need not be registered at the time that the charges are made. It is required however, that the alternate charged party be a verifiable charged party. Selection and verification is done

through internal actions in the SIP-AS. The Subscription Identification contains the identity of alternate charged party. The IMS session is then processed in the normal manner.

NOTE: The method for verifying the alternate charged party is not covered in the current release.

5.5.2 Credit control and balance management

Editor's note: There may be more issues to consider in this clause, e.g. consideration of proper amounts for reservation.

5.5.2.1 Use of credit pooling

Credit fragmentation can occur when it is necessary to grant separate quotas. Granting each quota causes some of the user's credit to be reserved at the Server. It is then possible that all the user's credit may be reserved when the user wishes to start using a new service. The new service may then be denied, despite the fact that there remains unused credit in the user's account.

To avoid such credit fragmentation and unnecessary load on the server, it is possible for multiple quotas provided to be linked into a credit pool. The client may then consider the quotas to form a single pool of credit, from which all services draw units.

The reference to a credit pool includes a translation factor derived from the rating parameter, which translates from units of a specific type (time/volume) to the abstract units in the pool.

The use of credit pooling is described in IETF RFC 4006 [402].

5.5.3 Inter-operator settlement of Charges

5.5.3.1 Inter-PLMN accounting

Inter-PLMN accounts for roaming traffic are determined in accordance with ITU-T principles (see ITU-T Recommendation D.93 [300]) and are settled by means of the GSM Association's Transferred Account Procedure (TAP).

5.5.3.2 'Visitors' from other PLMNs

The CDRs collected from the network also include details of the services employed by visiting (roaming) subscribers. The charges for Mobile Originated Calls (MOCs) and for supplementary services used are calculated as for home subscribers, converted to an agreed accounting currency and included in the CDRs for the TAP. Even if Mobile Terminated Calls (MTCs) are zero-priced in the visited network (VPLMN), in the absence of 'optimized routing' the MTC TAP records are still required by the home network (HPLMN) in order to determine the re-routing charges from the HPLMN to the VPLMN.

The TAP records generated are exchanged with each HPLMN on a regular basis. These TAP records form the basis of the invoice submitted by the VPLMN for the traffic carried.

5.5.3.4 'Home' subscribers roaming in other PLMNs

The HPLMN receives TAP records from each VPLMN for services employed by home subscribers whilst roaming. These records are employed to verify the invoices from the VPLMN and to bill the home subscribers for the services used. The charges contained in the TAP records are converted from the accounting currency to the local currency and a handling surcharge (mark-up) is added if required. The TAP records are subsequently passed to the subscriber billing process described in clause 5.1.2.1.

5.5.3.5 Fixed network operators and other service providers

The settlement of accounts with the operators of fixed networks for traffic carried, is generally performed on a bulk basis according to the principles outlined in the ITU-T D-series recommendations.

The traffic accounted for in this manner may include:

- outgoing (Mobile to Land) traffic;
- incoming (Land to Mobile) traffic;
- transit traffic, carried by intermediate networks;
- signalling (MAP/SCCP, CAP/SCCP) traffic such as location updates.

Accounting information may also be required for the use of services provided by other operators such as short message service centres and other Value Added Service (VAS) providers.

The charges for the various traffic shares may be determined on the basis of the CDRs generated by the network elements or on the basis of bulk counters (accounting meter records) in the gateway MSC servers (GMSC servers). For the purpose of the present document, the management information required is assumed to be derived from CDRs. The management of accounting meters is outside the scope of the present document.

5.5.4 Advice of Charge

The charging data collected from the network elements may be used to provide tariff information concerning the use of services, by both home and visiting subscribers, within the network. The appropriate tariff information to the network elements is distributed by the Advice of Charge supplementary service. The function is specified in TS 32.280 [69].

An alternative mode of AoC can also be used to indicate the occurrence of new charges to the user, e.g. when a monthly allowance is being exceeded, or when a service is requested that is not included in the subscription fees, while others are. This topic is for further study.

Annex A (informative): Bibliography

a) **The 3GPP charging specifications**

- 3GPP TS 32.252: "Telecommunication management; Charging management; Wireless Local Area Network (WLAN) charging".
- 3GPP TS 32.260: "Telecommunication management; Charging management; IP Multimedia Subsystem (IMS) charging".
- 3GPP TS 32.271: "Telecommunication management; Charging management; Location Services (LCS) charging".
- 3GPP TS 32.272: "Telecommunication management; Charging management; Push-to-talk over Cellular (PoC) charging".
- 3GPP TS 32.273: "Telecommunication management; Charging management; Multimedia Broadcast and Multicast Service (MBMS) charging".
- 3GPP TS 32.274: "Telecommunication management; Charging management; Short Message Service (SMS) charging".
- 3GPP TS 32.275: 'Telecommunication management; Charging management; MultiMedia Telephony (MMTel) charging'.

b) **Common 3GPP specifications**

- 3GPP TS 23.002: "Network architecture".

c) **other Domain and Service specific 3GPP / ETSI specifications**

- 3GPP TS 22.002: "Circuit Bearer Services (BS) supported by a Public Land Mobile Network
- 3GPP TS 22.003: "Circuit Teleservices Supported by a Public Land Mobile Network (PLMN)".
- 3GPP TS 22.004: "General on Supplementary Services".
- 3GPP TS 23.009: "Handover procedures"
- 3GPP TS 23.040: "Technical realization of the Short Message Service (SMS)".
- 3GPP TS 23.140: "Multimedia Messaging Service (MMS); Functional description; Stage 2".
- 3GPP TS 23.271: "Location Services (LCS); Functional description; Stage 2".

d) **Relevant ITU Recommendations**

- ITU-T Recommendation E.164: "The international public telecommunication numbering plan".
- ITU-T Recommendation Q.767: "Application of the ISDN user part of CCITT signalling System No.7 for international ISDN interconnections".
- ITU-T Recommendation X.25: "Interface between Data Terminal Equipment (DTE) and Data Circuit-terminating Equipment (DCE) for terminals operating in the packet mode and connected to public data networks by dedicated circuit".
- ITU-T Recommendation X.121: "International numbering plan for public data networks".

e) **Relevant IETF RFCs**

- IETF RFC 959 (1985): "File Transfer Protocol".
- IETF RFC 3588 (2003): "Diameter base protocol".

- IETF RFC1350: "The TFTP Protocol (Revision 2)".

Annex B (informative): Change history

Change history									
Date	TSG #	TSG Doc.	CR	Rev	Subject/Comment	Cat	Old	New	Work Item
Sep 2006	SP-33	SP-060540	0009	--	Extend the IMS correlation description for the access network to cover the fixed broadband access for multimedia data services (FBI-PCBL-CH)	C	6.4.0	7.0.0	
Dec 2006	SP-34	SP-060714	0011	--	Update of Flow Based Charging for PCC - Align with SA2 23.203	F	7.0.0	7.1.0	
Mar 2007	SP-35	SP-070044	0012	--	Add Alternate Charged Party (ACP) description to subscriber billing cases	B	7.1.0	7.2.0	
Sep 2007	SP-37	SP-070619	0013	--	Add online charging description to Alternate Charged Party (ACP)	B	7.2.0	8.0.0	
Dec 2007	SP-38	SP-070747	0014	--	Introduce SMS into the charging architecture - Align with 23.040 and 23.204	B	8.0.0	8.1.0	
Mar 2008	SP-39	SP-080059	0015	--	Add NE Interconnect Border Control Function (IBCF) to the IMS Charging architecture	B	8.1.0	8.2.0	IMSTSS
Jun 2008	SP-40	SP-080330	0016	1	Implication on overall Charging description for Common IMS	B	8.2.0	8.3.0	CH8
Jun 2008	SP-40	SP-080274	0017	-	Implications on overall charging architecture description for EPC Charging	B	8.2.0	8.3.0	EPC-CH
Sep 2008	SP-41	SP-080466	0018	-	R8 CR 32.240 Add missing reference points description	F	8.3.0	8.4.0	CH8
Sep 2008	SP-41	SP-080462	0019	-	Clarifications for EPC offline Charging	B	8.3.0	8.4.0	EPC-CH
Sep 2008	SP-41	SP-080462	0020	-	Alignment on Bx interface	D	8.3.0	8.4.0	EPC-CH
Dec 2008	SP-42	SP-080706	0021	-	Clarification on IMS-GWF involvement in the online charging	D	8.4.0	8.5.0	CH8

History

Document history		
V8.5.0	January 2009	Publication