

ETSI TS 132 252 V10.1.0 (2011-04)

Technical Specification

**Digital cellular telecommunications system (Phase 2+);
Universal Mobile Telecommunications System (UMTS);
LTE;
Telecommunication management;
Charging management;
Wireless Local Area Network (WLAN) charging
(3GPP TS 32.252 version 10.1.0 Release 10)**



ReferenceRTS/TSGS-0532252va10

KeywordsGSM, LTE, UMTS

ETSI

650 Route des Lucioles
F-06921 Sophia Antipolis Cedex - FRANCE

Tel.: +33 4 92 94 42 00 Fax: +33 4 93 65 47 16

Siret N° 348 623 562 00017 - NAF 742 C
Association à but non lucratif enregistrée à la
Sous-Préfecture de Grasse (06) N° 7803/88

Important notice

Individual copies of the present document can be downloaded from:

<http://www.etsi.org>

The present document may be made available in more than one electronic version or in print. In any case of existing or perceived difference in contents between such versions, the reference version is the Portable Document Format (PDF). In case of dispute, the reference shall be the printing on ETSI printers of the PDF version kept on a specific network drive within ETSI Secretariat.

Users of the present document should be aware that the document may be subject to revision or change of status.

Information on the current status of this and other ETSI documents is available at

<http://portal.etsi.org/tb/status/status.asp>

If you find errors in the present document, please send your comment to one of the following services:

http://portal.etsi.org/chaicor/ETSI_support.asp

Copyright Notification

No part may be reproduced except as authorized by written permission.
The copyright and the foregoing restriction extend to reproduction in all media.

© European Telecommunications Standards Institute 2011.

All rights reserved.

DECT™, **PLUGTESTS™**, **UMTS™**, **TIPHON™**, the TIPHON logo and the ETSI logo are Trade Marks of ETSI registered for the benefit of its Members.

3GPP™ is a Trade Mark of ETSI registered for the benefit of its Members and of the 3GPP Organizational Partners.

LTE™ is a Trade Mark of ETSI currently being registered

for the benefit of its Members and of the 3GPP Organizational Partners.

GSM® and the GSM logo are Trade Marks registered and owned by the GSM Association.

Intellectual Property Rights

IPRs essential or potentially essential to the present document may have been declared to ETSI. The information pertaining to these essential IPRs, if any, is publicly available for **ETSI members and non-members**, and can be found in ETSI SR 000 314: "*Intellectual Property Rights (IPRs); Essential, or potentially Essential, IPRs notified to ETSI in respect of ETSI standards*", which is available from the ETSI Secretariat. Latest updates are available on the ETSI Web server (<http://webapp.etsi.org/IPR/home.asp>).

Pursuant to the ETSI IPR Policy, no investigation, including IPR searches, has been carried out by ETSI. No guarantee can be given as to the existence of other IPRs not referenced in ETSI SR 000 314 (or the updates on the ETSI Web server) which are, or may be, or may become, essential to the present document.

Foreword

This Technical Specification (TS) has been produced by ETSI 3rd Generation Partnership Project (3GPP).

The present document may refer to technical specifications or reports using their 3GPP identities, UMTS identities or GSM identities. These should be interpreted as being references to the corresponding ETSI deliverables.

The cross reference between GSM, UMTS, 3GPP and ETSI identities can be found under <http://webapp.etsi.org/key/queryform.asp>.

Contents

Intellectual Property Rights	2
Foreword.....	2
Foreword.....	5
1 Scope	6
2 References	7
3 Definitions, symbols and abbreviations	8
3.1 Definitions	8
3.2 Symbols.....	8
3.3 Abbreviations	9
4 Architecture considerations	10
4.1 High level WLAN architecture	10
4.2 WLAN offline charging architecture.....	15
4.3 WLAN online charging architecture	16
5 WLAN charging principles and scenarios.....	17
5.1 WLAN charging principles	17
5.1.1 WLAN Direct IP Access charging.....	18
5.1.2 WLAN 3GPP IP Access charging	18
5.2 WLAN offline charging scenarios.....	18
5.2.1 Basic principles.....	18
5.2.1.1 Direct IP Access.....	18
5.2.1.2 3GPP IP Access	19
5.2.2 Wf message flows.....	20
5.2.2.1 Message Flows - WLAN session when WLAN access network supports accounting.....	20
5.2.2.2 Message Flows - WLAN session when WLAN access network does not support accounting.....	22
5.2.3 WLAN-AN-CDR generation.....	23
5.2.4 WLAN-CDR generation.....	23
5.2.4.1 Triggers for WLAN-CDR charging information collection.....	23
5.2.4.1.1 Triggers for WLAN-CDR Charging Information Addition.....	24
5.2.4.1.2 Triggers for WLAN-CDR closure.....	24
5.2.5 Ga record transfer flows	24
5.2.6 B _w CDR file transfer	24
5.3 WLAN online charging scenarios	25
5.3.1 Basic principles.....	25
5.3.2 Wo message flows	27
5.3.2.1 Message Flows - WLAN session were WLAN access network support Diameter Credit Control.....	27
5.3.2.2 Message Flows - WLAN session were WLAN access network support RADIUS/Diameter accounting (version 1).....	29
5.3.2.3 Message Flows - WLAN session were WLAN access network support RADIUS/Diameter accounting (version 2).....	31
5.3.2.4 Message Flows - WLAN session were WLAN access network don't support RADIUS/Diameter accounting.....	33
6 Definition of charging information	34
6.1 Data description for WLAN offline charging.....	34
6.1.1 Rf message contents.....	34
6.1.1.1 WLAN Direct IP Access Charging message contents	34
6.1.1.1.1 Charging Data Request Message	35
6.1.1.1.2 Charging Data Response Message.....	35
6.1.2 GTP' message contents	35
6.1.3 CDR Description on the Bw Interface	35
6.1.3.1 CDR Field Types	35
6.1.3.2 CDR Content.....	35
6.1.3.2.1 WLAN Direct IP Access CDR (WLAN-AN-CDR)	36

6.1.3.2.2	WLAN 3GPP IP Access charging message contents	37
6.2	Data description for WLAN online charging	37
6.2.1	Ro message contents	37
6.2.1.1	WLAN Direct IP Access Charging message contents	37
6.2.1.1.1	Debit/Reserve Unit Request message	38
6.2.1.1.2	Debit/Reserve Unit Response message	38
6.2.1.2	WLAN 3GPP IP Access Charging message contents	39
6.2.1.2.1	Debit/Reserve Unit Request message	39
6.2.1.2.2	Debit/Reserve Unit Response message	40
6.2.2	Detailed Message Formats	40
6.2.2.1	WLAN Direct IP Access Charging message contents	40
6.2.2.2	WLAN 3GPP IP Access Charging message contents	40
6.3	WLAN Charging specific parameters	40
6.3.1.1	WLAN charging information assignment for Service-Information	40
6.3.1.2	Definition of WLAN Information	41
6.3.2	Formal WLAN charging parameter description	41
6.3.2.1	WLAN charging information for CDRs	41
6.3.2.2	Definition of the WLAN charging events	41
Annex A (informative):	Bibliography	42
Annex B (normative):	Re-using the GGSN charging functions to implement the PDG charging functions.....	44
B.1	General	44
B.2	No re-use of policy control in the GGSN	44
B.2.1	Offline charging	45
B.2.2	Online charging	46
Annex C (informative):	Change history	47
History		48

Foreword

This Technical Specification has been produced by the 3rd Generation Partnership Project (3GPP).

The contents of the present document are subject to continuing work within the TSG and may change following formal TSG approval. Should the TSG modify the contents of the present document, it will be re-released by the TSG with an identifying change of release date and an increase in version number as follows:

Version x.y.z

where:

- x the first digit:
 - 1 presented to TSG for information;
 - 2 presented to TSG for approval;
 - 3 or greater indicates TSG approved document under change control.
- y the second digit is incremented for all changes of substance, i.e. technical enhancements, corrections, updates, etc.
- z the third digit is incremented when editorial only changes have been incorporated in the document.

1 Scope

The present document is part of a series of documents that specify charging functionality and charging management in GSM/UMTS networks. The GSM/UMTS core network charging architecture and principles are specified in 3GPP TS 32.240 [1], which provides an umbrella for other charging management documents that specify:

- the content of the CDRs per domain and subsystem (offline charging);
- the content of real-time charging messages per domain / subsystem (online charging);
- the functionality of online and offline charging for those domains and subsystems;
- the interfaces that are used in the charging framework to transfer the charging information (i.e. CDRs or charging events).

The complete document structure for these TSs is defined in 3GPP TS 32.240 [1].

The present document specifies the Offline and Online Charging description for the 3GPP interworked Wireless LAN (WLAN), based on the functional stage 2 description of 3GPP WLAN interworking in 3GPP TS 23.234 [201] as well as the Charging support and Charging differentiation for Mobility between 3GPP-Wireless Local Area Network (WLAN) interworking and 3GPP systems, based on the functional stage 2 description of mobility between 3GPP-WLAN and 3GPP systems in 3GPP TS 23.327 [202]. This charging description includes the offline and online charging architecture and scenarios specific to the 3GPP interworked WLAN, as well as the mapping of the common 3GPP charging architecture specified in 3GPP TS 32.240 [1] onto the 3GPP interworked WLAN. It further specifies the structure and content of the CDRs for offline charging, and the charging events for online charging. The present document is related to other 3GPP charging TSs as follows:

- The common 3GPP charging architecture is specified in 3GPP TS 32.240 [1].
- The parameters, abstract syntax and encoding rules for these CDR types are specified in 3GPP TS 32.298 [51].
- A transaction based mechanism for the transfer of CDRs within the network is specified in 3GPP TS 32.295 [54].
- The file based mechanism used to transfer the CDRs from the network to the operator's billing domain (e.g. the billing system or a mediation device) is specified in 3GPP TS 32.297 [52].
- The 3GPP Diameter application that is used for WLAN offline and online charging is specified in 3GPP TS 32.299 [50].

All terms, definitions and abbreviations used in the present document, that are common across 3GPP TSs, are defined in the 3GPP Vocabulary, 3GPP TR 21.905 [100]. Those that are common across charging management in GSM/UMTS domains or subsystems are provided in the umbrella document 3GPP TS 32.240 [1] and are copied into clause 3 of the present document for ease of reading. Finally, those items that are specific to the present document are defined exclusively in the present document.

Furthermore, requirements that govern the charging work are specified in 3GPP TS 22.115 [102].

2 References

The following documents contain provisions which, through reference in this text, constitute provisions of the present document.

- References are either specific (identified by date of publication, edition number, version number, etc.) or non-specific.
- For a specific reference, subsequent revisions do not apply.
- For a non-specific reference, the latest version applies. In the case of a reference to a 3GPP document (including a GSM document), a non-specific reference implicitly refers to the latest version of that document *in the same Release as the present document*.

- [1] 3GPP TS 32.240: "Telecommunication management; Charging management; Charging architecture and principles".
- [2]-[10] void.
- [11] 3GPP TS 32.251: "Telecommunication management; Charging management; Packet Switched (PS) domain charging".
- [12]-[49] Void.
- [50] 3GPP TS 32.299: "Telecommunication management; Charging management; Diameter charging applications".
- [51] 3GPP TS 32.298: "Telecommunication management; Charging management; Charging Data Record (CDR) parameter description".
- [52] 3GPP TS 32.297: "Telecommunication management; Charging management; Charging Data Records (CDR) file format and transfer".
- [53] Void
- [54] 3GPP TS 32.295: "Telecommunication management; Charging management; Charging Data Record (CDR) transfer".
- [55]-[70] Void.
- [71] 3GPP TS 23.125: "Overall high level functionality and architecture impacts of flow based charging; Stage 2".
- [72]-[99] Void.
- [100] 3GPP TR 21.905: "Vocabulary for 3GPP Specifications".
- [101]-[199] Void.
- [200] 3GPP TS 22.934: "Feasibility study on 3GPP system to Wireless Local Area Network (WLAN) interworking".
- [201] 3GPP TS 23.234: "3GPP system to Wireless Local Area Network (WLAN) interworking; System description".
- [202] 3GPP TS 23.327: "Mobility between 3GPP-Wireless Local Area Network (WLAN) interworking and 3GPP systems".
- [203] Void
- [204] 3GPP TS 29.234: "3GPP system to Wireless Local Area Network (WLAN) interworking; Stage 3".
- [205]-[400] Void.
- [401] IETF RFC 3588: "Diameter Base Protocol".

- [402] IETF RFC 4006: "Diameter Credit-Control Application".
- [403] Void
- [404] IETF RFC 4005: "Diameter Network Access Server Application".
- [405] IETF draft-ietf-geopriv-radius-lo-04: "Carrying Location Objects in RADIUS".

3 Definitions, symbols and abbreviations

3.1 Definitions

For the purposes of the present document, the terms and definitions given in 3GPP TR 21.905 [50], 3GPP TS 32.240 [1], 3GPP TS 22.934 [200], 3GPP TS 23.234 [201] and the following apply:

Billing Domain (BD): part of the operator network, which is outside the core network that receives and processes charging information from the core network charging functions.

It includes functions that can provide billing mediation and billing end applications.

Interworking WLAN (I-WLAN): a WLAN that interworks with a 3GPP system.

Offline Charging: charging mechanism where charging information **does not** affect, in real-time, the service rendered.

Online Charging: charging mechanism where charging information can affect, in real-time, the service rendered and therefore a direct interaction of the charging mechanism with bearer/session/service control is required.

PS based services: in WLAN interworking, PS based service is a general term to refer to the services provided by a PLMN using IP bearer capability between WLAN UEs and the PLMN in scenario 3 and upwards. They include all services provided by 3G PS domain that use the IP bearer service (e.g. IMS, Internet access, Corporate IP network access), and other services (e.g., SMS and LCS).

WLAN: Wireless LAN.

WLAN-attach status: indicates whether a UE is WLAN-attached or not. A WLAN UE is "WLAN-attached" after successful authentication and WLAN Access Authorization. A WLAN UE is "WLAN-detached" after its disconnection, or its authentication or WLAN access authorisation being cancelled.

Home Agent Access Point Name (HA-APN): is used to identify a specific PDN and a point of interconnection to that network (Home Agent).

3.2 Symbols

For the purposes of the present document, the following symbols apply:

Rf	Offline charging reference point between a 3G network element and the CDF
Ro	Online charging reference point between a 3G network element and the OCS
D'	Reference point between a pre-R6 HSS/HLR and a 3GPP AAA Server
Dw	Reference point between a 3GPP AAA Server and an SLF
Gr'	Reference point between a pre-R6 HSS/HLR and a 3GPP AAA Server
Wa	Reference point between a WLAN Access Network and a 3GPP AAA Server/Proxy (charging and control signalling)
Wd	Reference point between a 3GPP AAA Proxy and a 3GPP AAA Server (charging and control signalling)
Wf	Reference point between an Offline Charging System and a 3GPP AAA Server/Proxy
Wg	Reference point between a 3GPP AAA Server/Proxy and WAG
Wi	Reference point between a Packet Data Gateway and an external IP Network
Wm	Reference point between a Packet Data Gateway and a 3GPP AAA Server or 3GPP AAA proxy
Wn	Reference point between a WLAN Access Network and a WLAN Access Gateway
Wp	Reference point between a WLAN Access Gateway and a Packet Data Gateway
Wo	Reference point between a 3GPP AAA Server and an OCS

Wu	Reference point between a WLAN UE and a Packet Data Gateway
Wx	Reference point between an HSS and a 3GPP AAA Server

3.3 Abbreviations

For the purposes of the present document, the abbreviations defined in 3GPP TR 21.905 [50], 3GPP TS 22.934 [200], 3GPP TS 23.234 [201], 3GPP TS 23.934 (see bibliography), 3GPP TS 32.240 [1] and the following apply:

3GPP	3 rd Generation Partnership Project
BD	Billing Domain
CDR	Charging Data Record
EPS	Evolved Packet Systems
GGSN	Gateway GPRS Support Node
GTP	GPRS Tunnelling Protocol
I-WLAN	Interworking WLAN
IP	Internet Protocol
LAN	Local Area Network
PDG	Packet Data Gateway
PDP	Packet Data Protocol, e.g. IP
PS	Packet Switched
SGSN	Serving GPRS Support Node
TS	Technical Specification
TTG	Tunnel Termination Gateway
UMTS	Universal Mobile Telecommunications System
WLAN	Wireless LAN

4 Architecture considerations

4.1 High level WLAN architecture

The WLAN - 3GPP interworking architecture is specified in 3GPP TS 23.234 [201]. It distinguishes between two interworking scenarios:

- WLAN Access, Authentication and Authorization, which provides for access to the WLAN and the locally connected IP network (e.g. Intranet) to be authenticated and authorized through the 3GPP System. Access to a locally connected IP network from the WLAN, is referred to as WLAN Direct IP Access.
- WLAN 3GPP IP Access, which allows the WLAN UEs to establish connectivity with External IP networks, such as 3G operator networks, corporate Intranets or the Internet via the 3GPP system.
- WLAN Access Authentication and Authorisation and WLAN 3GPP IP Access are technically independent.

Figure 4.1.1 illustrates the basic WLAN networks from the point of view of 3GPP interworking.

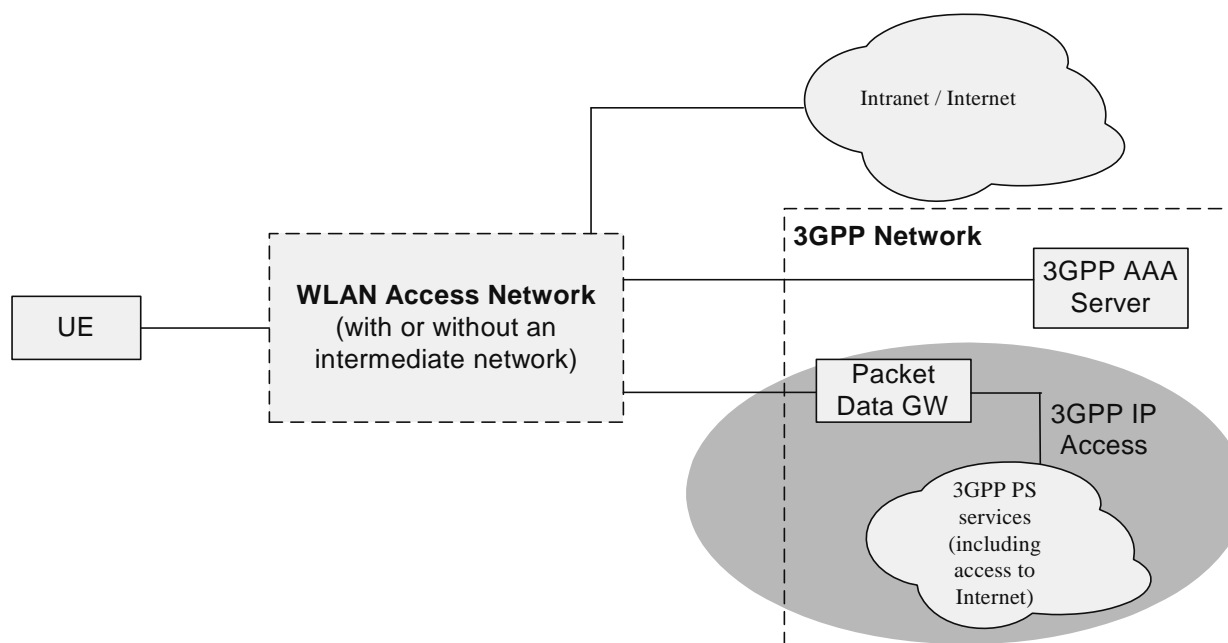
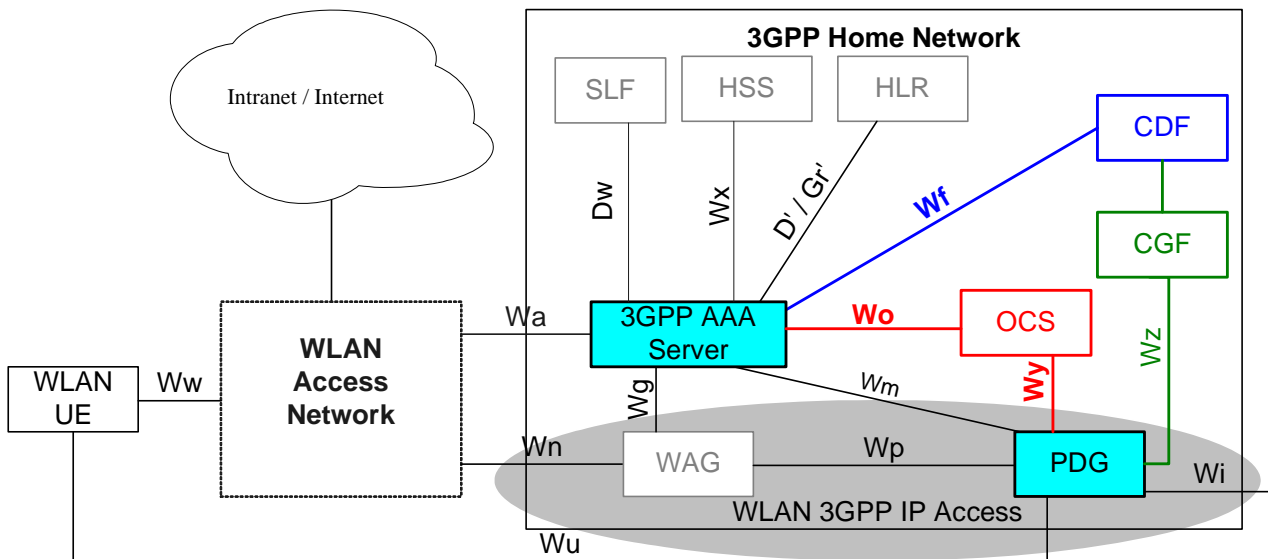

**Figure 4.1.1: Simplified WLAN Network Model
(the shaded area refers to WLAN 3GPP IP Access functionality)**

The Packet Data Gateway supports WLAN 3GPP IP Access to External IP networks. The WLAN includes WLAN access points and intermediate AAA elements. It may additionally include other devices such as routers. The WLAN User Equipment (WLAN UE) includes all equipment that is in possession of the end user, such as a computer, WLAN radio interface adapter, etc.

Editor's note: Appropriate mappings in clause 4 are needed, i.e. mapping between the logical charging functions as defined in 3GPP TS 32.240 and the WLAN charging entities.

Figure 4.1.2 depicts the non-roaming WLAN inter-working reference model for both Direct IP Access and 3GPP IP Access.



NOTE: The shaded area refers to WLAN 3GPP IP Access functionality.

Figure 4.1.2: Non Roaming Reference Model

Figure 4.1.3 depicts the roaming WLAN inter-working reference model where 3GPP PS based services are provided by the home PLMN based on 3GPP IP Access.

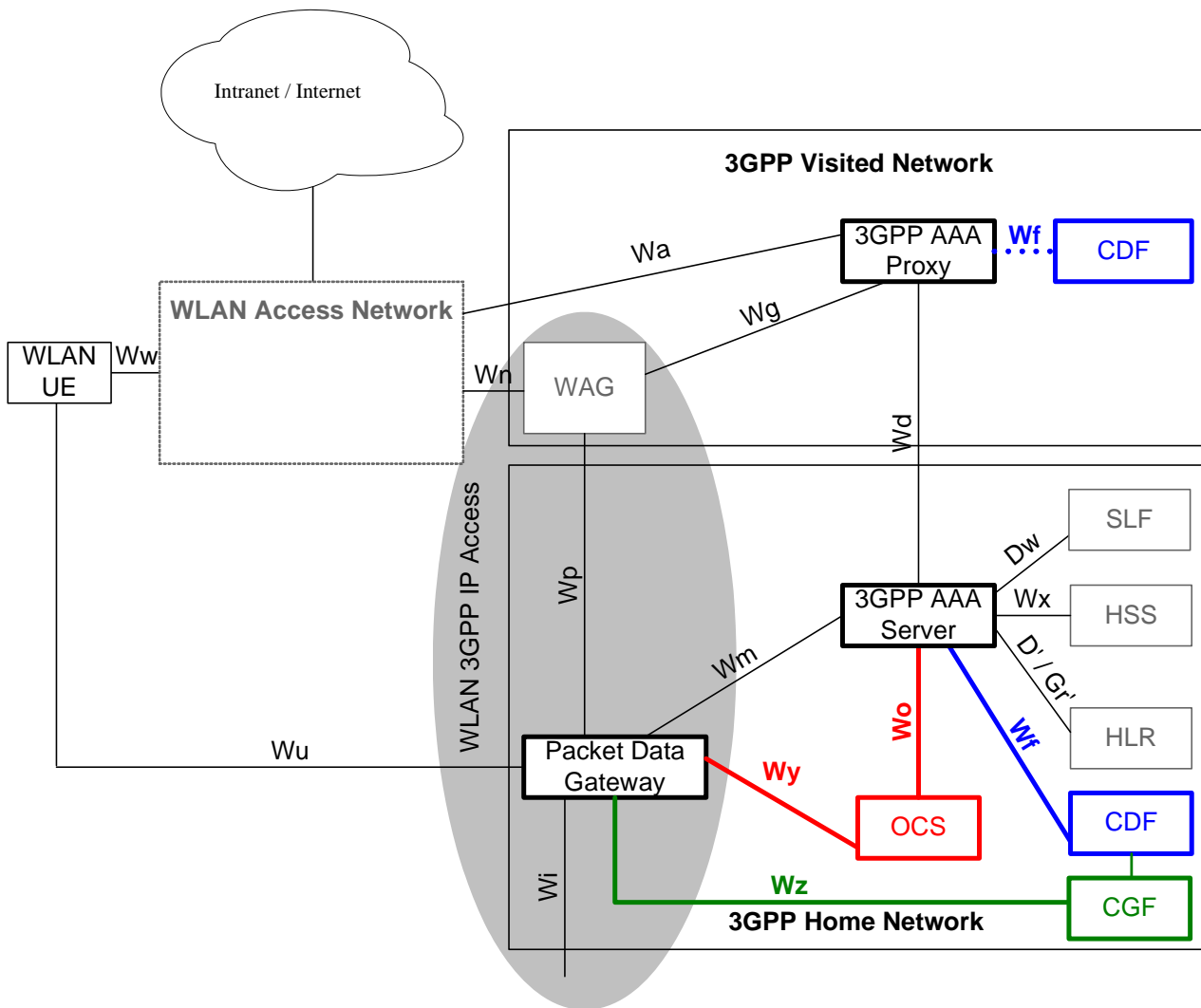

NOTE: The shaded area refers to WLAN 3GPP IP Access functionality.

Figure 4.1.3: Roaming reference model - 3GPP PS based services provided via the 3GPP Home Network

Finally, figure 4.1.4 shows the case of the 3GPP IP Access PS based services being provided by the visited PLMN. Note that there is no difference between figures 4.3 and 4.4 for the case of WLAN Access, Authentication and Authorisation.

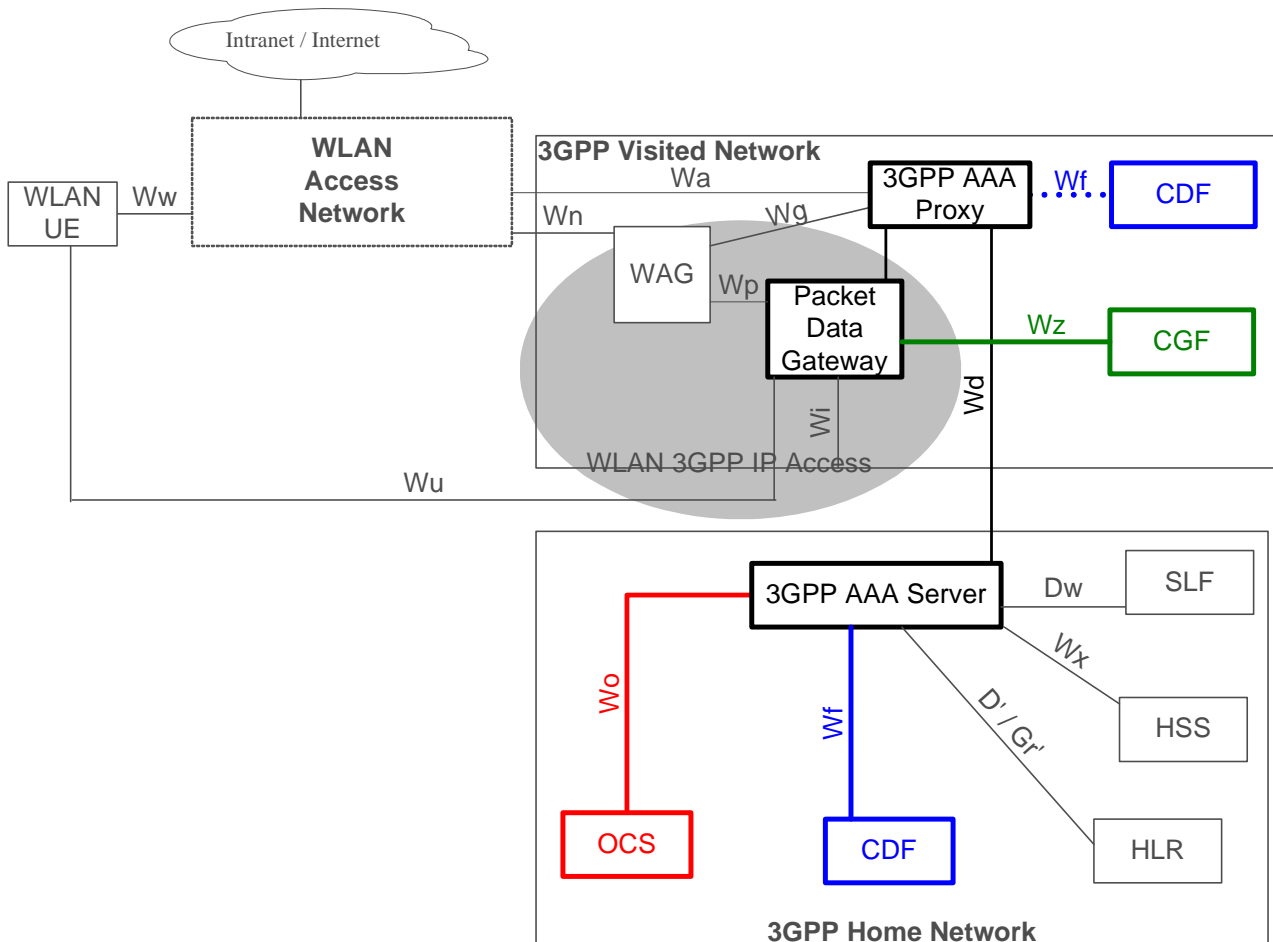

NOTE: The shaded area refers to WLAN 3GPP IP Access functionality.

Figure 4.1.4: Roaming reference model - 3GPP PS based services provided via the 3GPP Visited Network

Detailed descriptions of nodes and reference points in figures 4.1.2, 4.1.3 and 4.1.4 are provided in 3GPP TS 23.234 [201]. Following is a short description of each. Coloured nodes and reference points are relevant for charging thus explained in more detail.

WLAN UE: a WLAN UE is the User Equipment using a UICC card utilized by a 3GPP subscriber to access the WLAN network for 3GPP interworking purpose.

WLAN Access Network (WLAN AN): WLAN AN provides the wireless IP connectivity to the WLAN UE. It generates per user charging information about the WLAN AN usage. WLAN AN is outside of 3GPP scope.

3GPP AAA Proxy: the 3GPP AAA Proxy represents a proxying and filtering function that resides in the Visited 3GPP Network, i.e. it exists only in the roaming case. For charging purposes the 3GPP AAA Proxy functions include:

- relaying the AAA information between WLAN and the 3GPP AAA Server;
- reporting per-user charging/accounting information to the VPLMN offline charging system for roaming users;
- protocol conversion when the Wa and Wd reference points do not use the same protocol. This function is dependent on inter-operator agreements;

For WLAN 3GPP IP Access only:

- Receiving per-tunnel charging information based on the tunnel identifier from the WAG and mapping of a user identifier and a tunnel identifier from the PDG; generating per user charging records for roaming users.

3GPP AAA Server: the 3GPP AAA server is located within the 3GPP HPLMN. It performs the AAA functions and may also act as an AAA proxy. For WLAN 3GPP IP Access it provides authorization, policy enforcement and routing information to the PDG, WAG and WLAN AN. For charging the 3GPP AAA Server:

- generates and reports per-user charging/accounting information to the HPLMN CDF;
- performs online charging control for the WLAN AN.

WLAN Access Gateway (WAG): the WAG applies to a WLAN 3GPP IP Access enabled system. It is a gateway via which the data to/from the WLAN Access Network is routed via the PLMN to provide a WLAN UE with 3G PS based services in a WLAN 3GPP IP Access enabled system. The WLAN Access Gateway resides in the VPLMN in the roaming case, and in the HPLMN in the non-roaming case. From charging point of view the WLAN Access Gateway:

- allows VPLMN to generate charging information for users accessing via the WLAN AN in the roaming case;
- performs collection of per tunnel accounting information, e.g. volume count (byte count) and elapsed time, to be used e.g. for inter-operator settlements.

NOTE 1: Per tunnel accounting generation in the WAG is not required when the WAG and PDG are in the same network.

Packet Data Gateway: the Packet Data Gateway (PDG) applies to a WLAN 3GPP IP Access enabled system. 3GPP PS based services are accessed via a PDG in the user's Home Network or a PDG in the selected VPLMN. 3GPP PS based services may be accessed via a PDG in the user's HPLMN or a PDG in the selected VPLMN. From charging point of view the Packet Data Gateway:

- generates charging information related to user data traffic for offline and online charging purposes;
- may apply IP flow based bearer level charging, e.g. in order to differentiate or suppress WLAN bearer charging for 3GPP PS based services.

Editor's Note: PDG functionality may be provided by re-using the existing GGSN functionality. The current working assumption is that the TPF is a logical function allocated to the PDG providing IP flow based bearer level charging capabilities.

Following is a functional description of the reference points depicted in the above figures.

Wa: the Wa reference point connects the WLAN Access Network, possibly via intermediate networks, to the 3GPP Network (i.e. the 3GPP AAA Proxy in the roaming case and the 3GPP AAA server in the non-roaming case). The prime purpose of the protocols crossing this reference point is to transport authentication, authorization and charging-related information in a secure manner. The reference point has to accommodate also legacy WLAN Access Networks.

Wz: this reference point is used by the PDG for transfer of offline charging records from the PDG CDF to the CGF. The prime purpose of the protocols crossing this reference point is to transport/forward charging information towards 3GPP operator's offline charging system, located in the VPLMN or HPLMN.

Wy: this reference point is an intra-operator interface used by the PDG to communicate with the Online Charging System. Wy is present when the PDG is located in the HPLMN (in the non-roaming case as described in figure 4.1.2 or in the roaming case with 3GPP PS based services provided via the 3GPP home network as described in figure 4.1.3). Wm, Wd, Wo are used instead in the roaming case with 3GPP PS based services provided via the 3GPP visited network as described in figure 4.1.4. The prime purpose of the protocol(s) crossing this reference point is to transport online charging related information so as to perform credit control for the online charged subscriber. This reference point applies the common 3GPP online charging interface as specified in 3GPP TS 32.299 [50].

Wm: this reference point applies to WLAN 3GPP IP Access.

The Wm reference point is located between

- 3GPP AAA Server and Packet Data Gateway when the PDG is located in the HPLMN (in the non-roaming case as described in figure 4.1.2 or in the roaming case with 3GPP PS based services provided via the 3GPP home network as described in figure 4.1.3)

- respectively between 3GPP AAA Proxy and Packet Data Gateway when the PDG is located in the VPLMN (in the roaming case with 3GPP PS based services provided via the 3GPP visited network as described in figure 4.1.4).

The functionalities of this reference point are described in 3GPP TS 23.234 [201].

Wo: the Wo reference point is used by the 3GPP AAA Server to communicate with 3GPP Online Charging System (OCS). The prime purpose of the protocol(s) crossing this reference point is to transport online charging related information so as to perform credit control for the online charged subscriber. This reference point applies the common 3GPP online charging interface as specified in 3GPP TS 32.299 [50].

Wf: the Wf reference point is located between the 3GPP AAA Server and 3GPP offline charging system. The prime purpose of the protocols crossing this reference point is to transport/forward charging information towards 3GPP operator's offline charging system, located in the VPLMN or HPLMN, so as to generate CDRs for offline charged subscribers and to calculate inter-operator accounting.

The components of the "offline charging system" are further explained in clause 4.2.

This reference point applies the 3GPP Diameter based offline charging interface as specified in 3GPP TS 32.299 [50].

Wd: the Wd reference point applies to roaming cases only. The Wd reference point connects the 3GPP AAA Proxy, possibly via intermediate networks, to the 3GPP AAA Server. The prime purpose of the protocols crossing this reference point is to transport authentication, authorisation and related information. The functionality of the reference point is to transport AAA messages including charging signalling per WLAN user used for purging a user from the WLAN access for immediate service termination.

NOTE 2: Throughout the rest of the present current document, 'Rf' is used in place of 'Wf', and, 'Ro' is used in place of 'Wo' and 'Wy' for reasons explained in 3GPP TS 32.240 [1].

4.2 WLAN offline charging architecture

As described in 3GPP TS 32.240 [1], the CTF (an integrated component in each charging relevant NE) generates charging events and forwards them to the CDF. The CDF, in turn, generates CDRs which are then transferred to the CGF. Finally, the CGF creates CDR files and forwards them to the Billing Domain.

The following WLAN network elements are involved in WLAN charging process - the WLAN Access Network, the WLAN AAA Proxy/Server, and the PDG, implying that they have an integrated CTF. The distribution of the CDF and CGF logical functions differs from network element to network element. For the purposes of this TS, the distributions in figure 4.2 are considered.

WLAN AN: The CTF is integrated in to the WLAN AN. The CDF and the CGF are external to the WLAN AN.

Editor's note: The CTF ... TBD

3GPP AAA Proxy: The 3GPP AAA Proxy proxies the charging information received from the WLAN AN over the Wa reference point to a CDF in the visited network over a Wf reference point, and, to a 3GPP AAA Server in the subscriber's home network over the Wd reference point. The 3GPP AAA Proxy is relevant only in a roaming case.

3GPP AAA Server: A 3GPP AAA Server proxies the charging information received from the WLAN AN over the Wa reference point (in a non-roaming case) or charging information received from the 3GPP AAA Proxy Server located in a visited network over the Wd reference point (in a roaming case) to the CDF over the Wf reference point.

WLAN PDG: The CTF and CDF are integrated in the PDG; however, the CGF may exist as a physically separate entity or integrated to the PDG. If the CGF is external to the PDG, then the CDF forwards the CDRs to the CGF across the Ga interface.

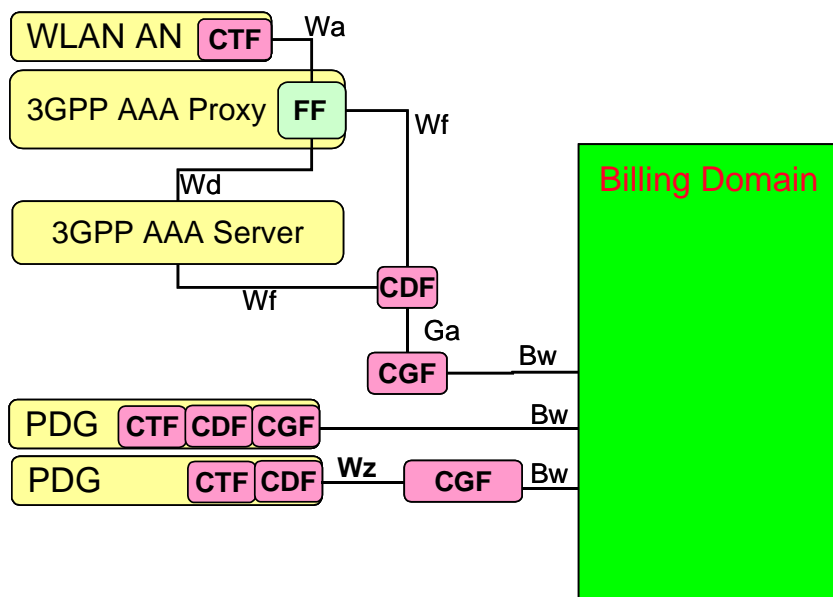

NOTE 1: This is a purely function architecture and it does not distinguish between a roaming and non-roaming case.
 NOTE 2: Any physical co-location of CGF, CDF and AAA Server / Proxy is possible.

Figure 4.2: Functional WLAN offline charging architecture

The Diameter based Rf interface on which the Wf interfaces are based on is described in 3GPP TS 32.299 [50].

4.3 WLAN online charging architecture

WLAN online charging based on the AAA and PDG functions utilise the Ro interface (Wy reference point) and application as specified in 3GPP TS 32.299 [50]. The WLAN online charging architecture is depicted in figure 4.3.

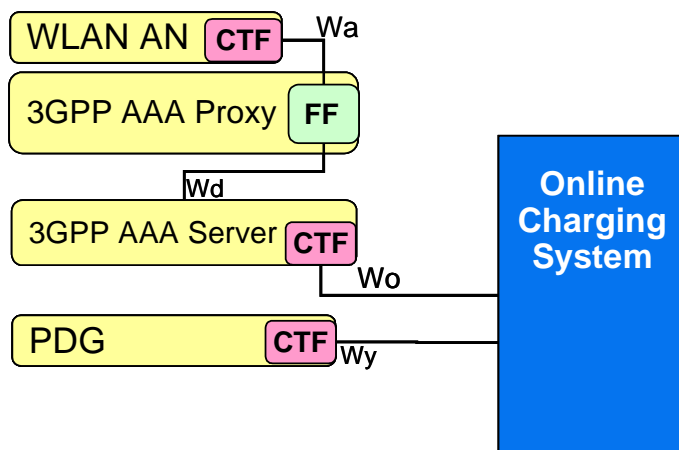

NOTE: The online charging system is always a part of the subscriber's home network.

Figure 4.3: Functional WLAN online charging architecture

The Ro reference point includes the functionality defined for the Gy reference point (required for the TPF) in 3GPP TS 23.125 [70]. Refer to clause 5.2.1.3, TS 32.240 [1] and TS 23.125 [70] for further details on FBC.

Details on the interfaces and functions can be found in 3GPP TS 32.240 [1] for the general architecture components, 3GPP TS 32.296 [53] for the OCS, and TS 32.299 [50] for the 3GPP accounting and credit control application.

5 WLAN charging principles and scenarios

The following functionality and requirements have been identified for charging:

- The WLAN Access Network shall be able to report the WLAN access usage to the appropriate 3GPP system (i.e. VPLMN in the roaming case and HPLMN in the non-roaming case).
- It shall be possible for the 3GPP system to control a specific ongoing WLAN access session for online charging purposes.
- It shall be possible for an operator to maintain a single prepaid account for WLAN, PS, CS, and IMS for a user.
- The 3GPP system shall be able to process the WLAN access resource usage information, and convert it into the format used in 3GPP networks (e.g. CDR).
- It shall be possible to correlate charging and accounting records generated in WLAN Access related nodes and records generated in 3GPP nodes.
- It shall be possible to apply offline charging and online charging mechanisms for the WLAN interworking with 3GPP network.

Additionally, for WLAN 3GPP IP Access:

- It shall be possible to generate per user charging information in the HPLMN and in the VPLMN irrespective of whether the service is provided in the HPLMN or in the VPLMN.

5.1 WLAN charging principles

WLAN charging comprises of: the WLAN Direct IP Access charging and WLAN 3GPP IP Access charging. WLAN Direct IP Access charging is always on when a user is connected to the WLAN Access Network. WLAN 3GPP IP Access charging is performed only when 3G PS services are used.

The WLAN Direct IP Access offline charging is based on the charging information received from the WLAN AN. In the roaming case the 3GPP AAA Proxy, depending on the protocol at the Wa reference point, either forwards the Accounting Requests over the Wd reference point or performs Radius-Diameter translation. 3GPP AAA Proxy also translated and forwards the Accounting Messages over the Wf reference point to the visited CDF. The 3GPP AAA Server at the home network supports both Wa and Wd reference points for non-roaming and roaming scenarios respectively. The 3GPP AAA Server may translate and forward the Accounting Requests to the home CDF over the Wf reference point.

The Wa and Wd reference points and related protocol conversions are specified in the 3GPP TS 29.234 [204]. Wf reference point is based on Rf interface specified in 3GPP TS 32.299 [50].

The user is identified by MSISDN and IMSI, while a unique identifier generated by the PDG (PDG Charging Id) is used to determine the bearer in PDG. PDG Charging Id is also forwarded to the AAA server and AAA server is returning unique WLAN Session Id so as to allow correlation of AAA server charging data with the matching PDG charging data in the BD. The PDG shall use the Charging Characteristics to determine charging profile to be used. The Charging Characteristics contains the index to certain charging profile configured in PDG. Multiple charging profiles may be configured on the PDG to allow different sets of trigger values. The PDG should use W-APN Charging Characteristics if available. If W-APN Charging Characteristics is not available Subscribed Charging Characteristics should be used. If no Charging Characteristics is available default charging profile shall be used.

Editor's Note: In case a WLAN UE accessing local services offered by the WLAN AN and simultaneously establishing a connection to an external IP network via its HPLMN network. In this scenario we assume that both the AAA server and the PDG shall generate charging information. The WLAN AN shall report all the traffic generated by the WLAN UE to the AAA server (i.e.: traffic to the local connection in the WLAN AN and to the PDG) and the PDG shall report the online/offline systems all the traffic routed so in this case: shall the traffic routed through the PDG be charged twice?. How could this situation be avoided?.

Editor's Note: SA5 SWG-B agrees that the following shall be replaced as follows:

Wo with Ro
Wy with Ro
Wf with Rf
Wz & Gz with Ga

Editor's Note: Take input from 32.270. Remove all occurrences of protocols from this specification.

Editor's Note: Include basic principles as described for PS from TS 32.251.

5.1.1 WLAN Direct IP Access charging

WLAN AN is responsible for generating per user charging data and monitoring usage for WLAN Direct IP Access. Charging data is sent, possibly via 3GPP AAA Proxy (roaming case) to the 3GPP AAA Server. The 3GPP AAA Server connects to the appropriate charging system. In case of roaming, the 3GPP AAA Proxy sends the charging information also to the CDF at the visited network for roaming settlement purposes. WLAN Direct IP Access charging uses the capabilities of the WLAN AN to report the uplink and downlink data volumes and the duration of the session.

5.1.2 WLAN 3GPP IP Access charging

Packet Data Gateway is responsible for collecting and reporting usage of WLAN 3GPP IP Access. PDG shall collect charging information like session usage times and data volumes. PDG shall report charging information per user and per bearer (per connection). Furthermore, to be able to report charging information per service data flow or per rating group, Flow Based Charging (FBC) is supported by the PDG by the integration of a TPF, see 3GPP TS 23.125 [71].

Charging rules for FBC may be pre-defined in TPF or dynamically provisioned to the TPF over Gx reference point.

Editor's Note: The role of the WAG for end user charging is TBD. Potentially it is only used by the visited network to identify the amount of data relayed between the WLAN AN and the HPLMN and used for roaming settlement. Note that the charging information from the WLAN AN does not differentiate the user data transferred between the WLAN AN and PDG and between the WLAN AN and IP network directly connected to the WLAN AN. Hence, WLAN AN information can not be used to identify how much data the VPLMN has relayed.

Editor's Note: It is necessary to verify if the proposed correlation mechanism would work in case the WLAN UE establishes several simultaneous Isec tunnels against the same or different PDGs (connections to different IP networks requesting different WAPNs): How shall the AAA server differentiate the charging data from the WLAN AN and associate it with the correct charging identifier received from the PDGs for each WAPN?.

Editor's Note: Procedure needs to be verified from CN4. The following description needs to be clarified: Correlation of PDG and WLAN AN charging data is enabled by exchanging correlation identifiers. When the PDG requests tunnel authorisation over the Wm reference point, it sends the PDG Charging Identifier to the 3GPP AAA Server. In the response the 3GPP AAA Server sends the WLAN Session ID back to the PDG. PDG includes the WLAN Session ID to the PDG charging data. 3GPP AAA Server includes the PDG Charging Identifier to the WLAN AN charging data.

5.2 WLAN offline charging scenarios

5.2.1 Basic principles

5.2.1.1 Direct IP Access

Editor's Note: Detail the chargeable events here as for 3GPP IP Access below.

Offline charging protocol conversions and related functionality are illustrated in the figures 5.2.1 and 5.2.2.

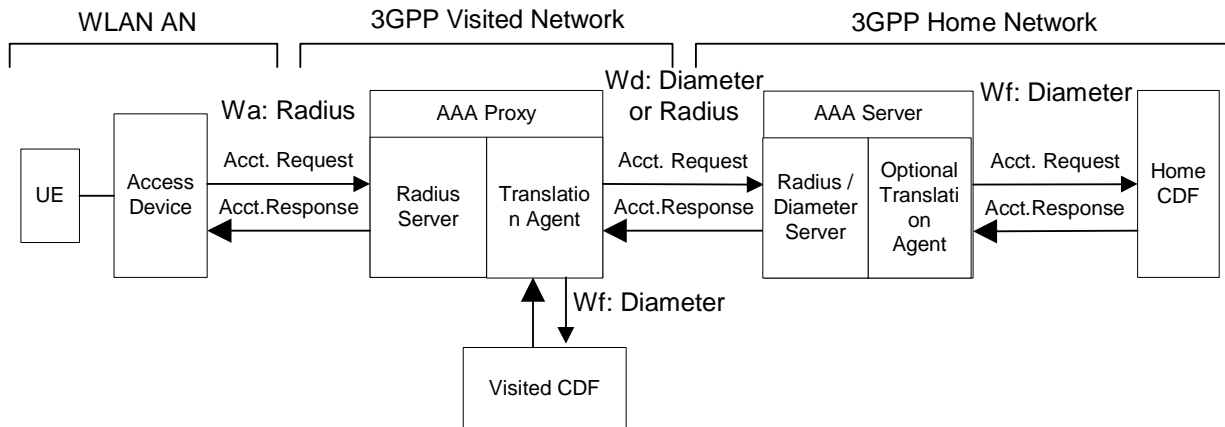

Figure 5.2.1: Offline Charging Accounting Requests - Wa based on Radius

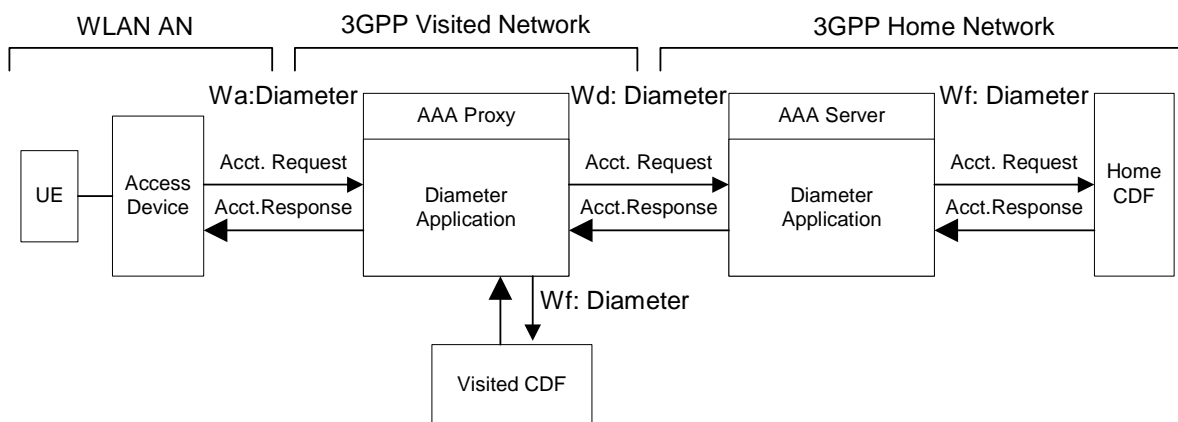

Figure 5.2.2: Offline Charging Accounting Requests - Wa based on Diameter.

Editor's Note: The physical mapping of CDF / CGF and the supported configurations are for further study. Options are to integrate CDF and CGF (implementing only Wf interface) or to integrate 3GPP AAA Server/Proxy and CDF (implementing Ga-like interface towards CGF), or to integrate 3GPP AAA Server/Proxy, CDF and CGF (typical AAA infrastructure deployment).

5.2.1.2 3GPP IP Access

When 3GPP IP Access is used, PDG is collecting and reporting charging data. The following chargeable events are defined for PDG:

- Start of bearer in PDG. Upon encountering this event, a new WLAN-CDR for this context is created.
- Start of service data flow. A volume count for this service data flow is started if service data flow specific reporting is required. If rating group specific reporting is required a new volume count is started only if this is the first service data flow using that specific rating group.
- Termination of service data flow. If reporting is done per service data flow, the service data flow volume counters are closed. If reporting is done per rating group the volume counters are closed only if this is the last service data flow using that particular rating group.
- End of bearer in the PDG. The WLAN-CDR is closed upon encountering this trigger.
- Expiry of an operator configured time limit for bearer. This event closes the WLAN-CDR, and a new one is opened if the bearer is still active.
- Expiry of an operator configured data volume limit for bearer. This event closes the WLAN-CDR, and a new one is opened if the bearer is still active.

- Change of charging condition: e.g. tariff time change. When this event is encountered, all current volume counts are captured and new volume counts for all active service data flows are started.
- Expiry of an operator configured container limit per CDR. This event closes the WLAN-CDR, and a new one is opened if the bearer is still active.

Management intervention may also force trigger a chargeable event.

5.2.2 Wf message flows

The flows described in the present document specify the charging communications between WLAN access network and the CDF for different charging scenarios.

5.2.2.1 Message Flows - WLAN session when WLAN access network supports accounting

Figure 5.2.2.1 shows the Charging Data transactions that are required between 3GPP AAA server and CDF during a WLAN session were the WLAN access network support RADIUS or Diameter accounting.

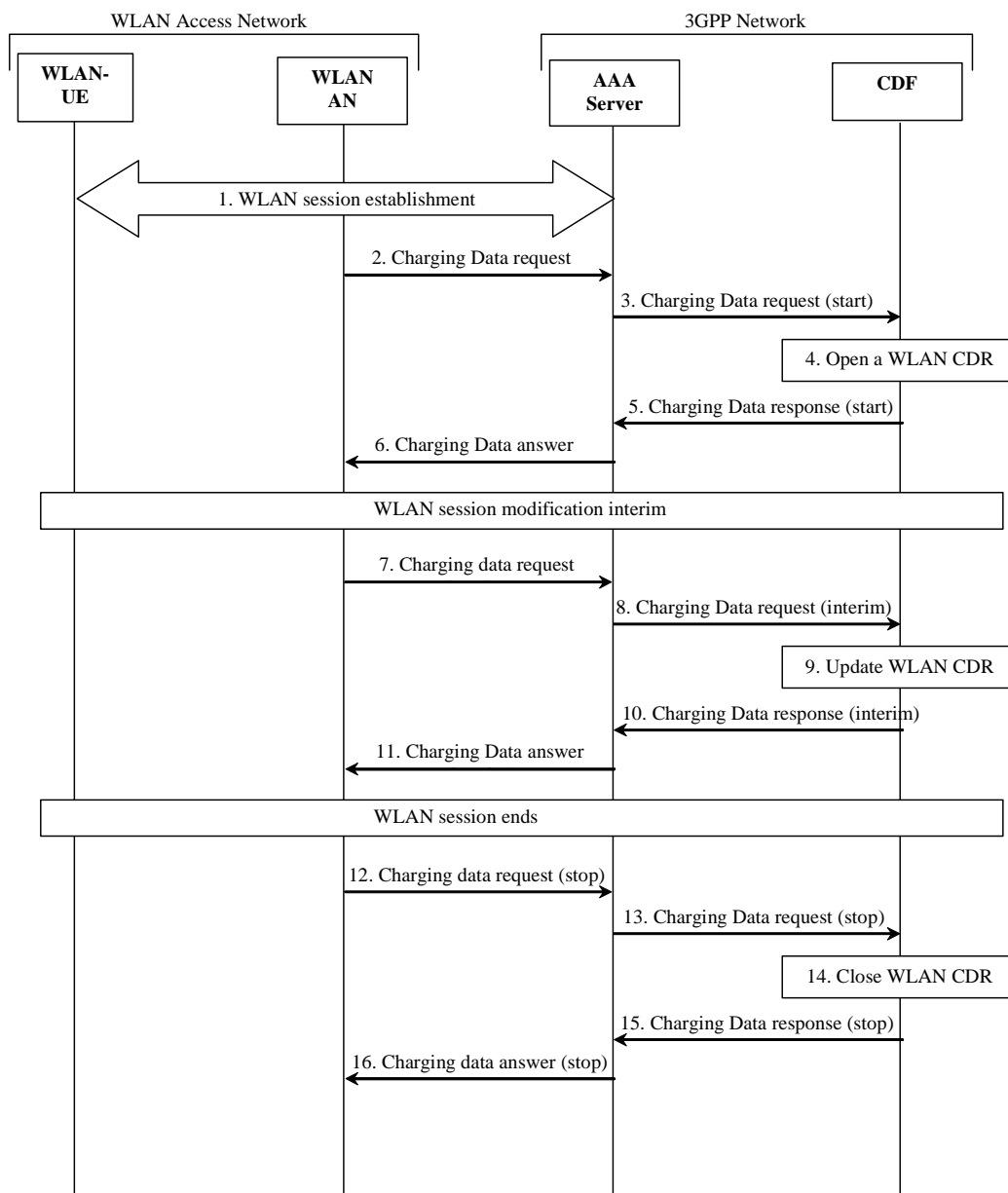

Figure 5.2.2.1: Message Sequence Chart for WLAN session when WLAN AN supports accounting

Editors Note: Change names on 3GPP AAA server to CDF messages.

1. The WLAN UE establishes a WLAN session.
2. The WLAN access networks starts accounting with a charging data start request.
3. The 3GPP AAA converts the accounting request to a Charging Data request message and sends it to CDF.
4. CDF opens a WLAN CDR with information in the Charging Data request message.
5. CDF acknowledges the Charging Data request with a Charging Data response message.
6. 3GPP AAA server converts the Charging Data response message to charging data answer message. It sends the accounting answer to the WLAN access network.
7. The WLAN access networks updates accounting with a charging data interim request.
8. The 3GPP AAA server converts the charging data message to a Charging Data request message sends it to CDF.
9. CDF updates the WLAN CDR with information in the Charging Data request message.
10. CDF acknowledges the Charging Data request with a Charging Data response message.
11. 3GPP AAA server converts the Charging Data response message to charging data answer message. It sends the accounting answer to the WLAN access network.
12. The WLAN access networks stops accounting with a charging data stop request.
13. The 3GPP AAA server converts the accounting message to a Charging Data request message send it to CDF
14. CDF updates the WLAN CDR with information in the Charging Data request message. CDF also closes the CDR.
15. CDF acknowledges the Charging Data request with a Charging Data response message.
16. 3GPP AAA server converts the Charging Data response message to accounting answer message. It sends the accounting answer to the WLAN access network.

NOTE: There can be more then one interim accounting transactions within a WLAN session. CDF/3GPP AAA server defines the interim report interval.

5.2.2.2 Message Flows - WLAN session when WLAN access network does not support accounting

Figure 5.2.2.2 shows the Charging Data transactions that are required between 3GPP AAA server and CDF during a WLAN session when the WLAN access network doesn't support RADIUS or Diameter accounting.

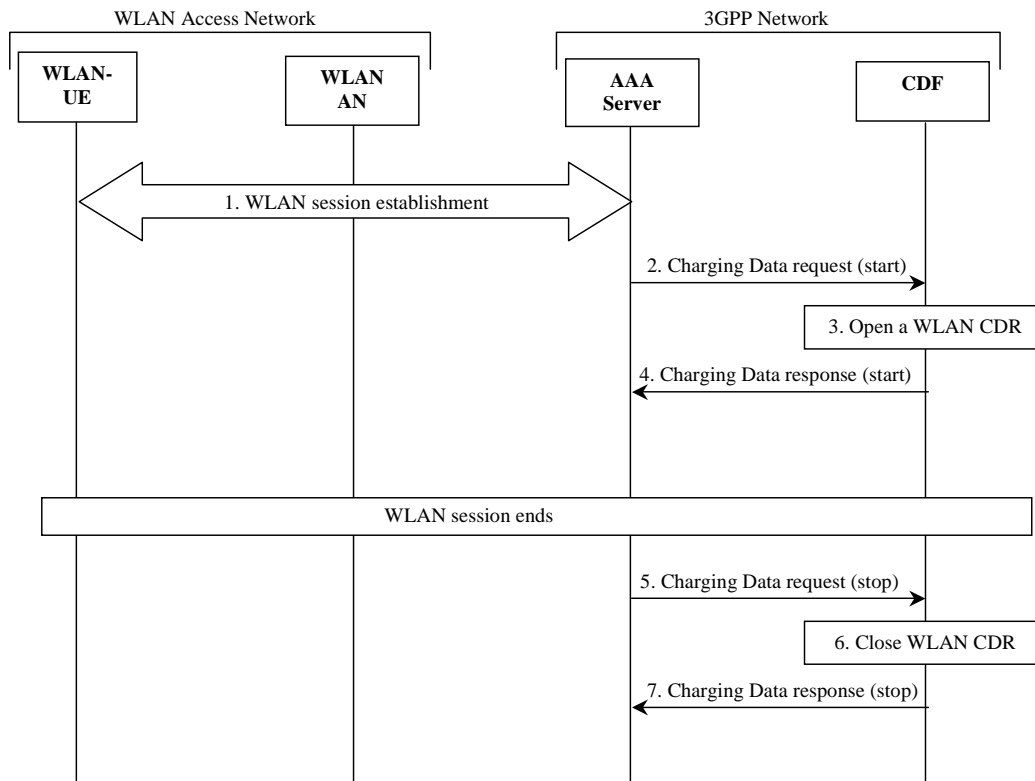

Figure 5.2.2.2: Message Sequence Chart for WLAN session when WLAN AN don't support accounting

1. The WLAN UE establishes a WLAN session.
2. The 3GPP AAA generates a Charging Data request message based on information from authentication/authorization and sends it to CDF.
3. CDF opens a WLAN CDR with information in the Charging Data Request message.
4. CDF acknowledges the Charging Data request with a Charging Data response.
5. The 3GPP AAA server generates an Charging Data request stop message based on session end information from WLAN AN and send it to CDF.
6. CDF updates the WLAN CDR with information in the Charging Data request message. CDF also closes the CDR.
7. CDF acknowledges the Charging Data request with a Charging Data response.

NOTE: In this case will up/down link volume counters not be present in the CDRs.

5.2.3 WLAN-AN-CDR generation

In Direct IP Access Charging CDF/CGF generates WLAN-AN-CDR to collect charging information.

Charging profile includes information whether CDR generation is activated. If CDR generation is activated, WLAN-AN-CDRs are generated for the Direct IP Access session based on the Accounting-Messages originated from the WLAN AN. WLAN-AN-CDR is generated upon session termination. Intermediate WLAN-AN-CDRs may be generated upon an arrival of an intermediate Accounting-Message for a session. It shall be possible to define separate trigger conditions values per charging profile for WLAN-AN-CDR generation for the following triggers:

- Upon each intermediate Accounting-Message.
- Upon intermediate Accounting-Message when data volume limit is exceeded.
- Upon intermediate Accounting-Message when time limit (duration) is exceeded.

Editor's Note: Whether CDRs may be generated by CDF, CGF or both is FFS. If Ga interface is omitted, the combined CDF/CGF generates the CDR files.

5.2.4 WLAN-CDR generation

In 3GPP IP Access Charging PDG generates WLAN-CDR to collect charging information that is subsequently transferred to the Charging Gateway Function (CGF).

Charging profile includes information whether CDR generation is activated. If CDR generation is activated, it shall be possible to define separate trigger conditions values per charging profile for the following triggers:

- data volume limit for the bearer (i.e. for the mirror SDF);
- time (duration limit) for the bearer (i.e. for the mirror SDF);
- maximum number of containers.

The following clauses describe the trigger conditions for the chargeable events described in clause 5.2.1. In 3GPP IP Access offline charging, these chargeable events correspond to the triggers for collection of charging information and WLAN-CDR generation by the PDG.

5.2.4.1 Triggers for WLAN-CDR charging information collection

WLAN-CDR is used to collect charging information related to the 3GPP IP Access connection for a UE in the PDG, where the data volumes within each WLAN-CDR are separately counted per defined service data flow or rating group.

Many "List of Service Data Volumes" containers per bearer can be active simultaneously and each container includes charging data of one particular service data flow or several service data flows belonging to the same rating group. A new container is activated when traffic for a defined service data flow or new rating group is detected. A container is closed when the termination of the service data flow is detected and reporting is per service data flow. If reporting is per rating group, service data volume container is closed only if this is the last service data flow using that particular rating group.

If, according to the Charging Characteristics, CDR generation is activated a WLAN-CDR shall be opened at bearer activation. When a change of charging condition occurs, all service data flow volume counts are added to the WLAN-CDR and new counts are started.

The subsequent clauses identify in detail the conditions for adding information to, and closing the WLAN-CDR for delivery towards the CGF.

5.2.4.1.1 Triggers for WLAN-CDR Charging Information Addition

The "List of Service Data Volumes" attribute of the WLAN-CDR consists of a set of containers. Each container includes volume counters per a service data flow or per rating group. Each container identifies the volume count within the same bearer separated for uplink and downlink. Figure 5.2.4.1.1 identifies, which conditions are supported to trigger WLAN-CDR charging information addition.

Table 5.2.4.1.1: Triggers for WLAN-CDR charging information addition

Trigger Conditions	Description/Behaviour
Tariff Time Change	On reaching the Tariff Time Change a set of "List of Service Data Volumes" containers, i.e. all containers, shall be added to the CDR.
Service data flow Change	A "List of Service Data Volumes" container is closed when termination of service data flow is detected and reporting is per service data flow. If reporting is per rating group "List of Service Data Volumes" container is closed only if this was the last service data flow for that rating group.
CDR Closure	All active "List of Service Data Volumes" containers shall be added to the WLAN-CDR.

5.2.4.1.2 Triggers for WLAN-CDR closure

The WLAN-CDR shall be closed on encountering some trigger conditions. Table 5.2.4.1.2 identifies which conditions are supported to permit closure of the WLAN-CDR.

Table 5.2.4.1.2: Triggers for WLAN-CDR closure

Closure Conditions	Description/Behaviour
End of bearer within the PDG	Deactivation of the bearer shall result the CDR being closed. The trigger condition covers: <ul style="list-style-type: none"> - termination of bearer; - any abnormal release.
Partial Record Reason	O&M reasons permit the closure of the CDR for internal reasons. The trigger condition covers: <ul style="list-style-type: none"> - data volume limit for the bearer; - time (duration) limit for the bearer; - maximum number of containers; - management intervention.

The Partial Record generation trigger thresholds are those associated with the Charging Characteristics. The Partial Record generation trigger thresholds are PDG configuration parameters defined per charging profile by the operator through O&M means. Data volume and time limit trigger thresholds are for the mirror SDF only i.e. for the bearer.

In the event that the WLAN-CDR is closed and the PDP context remains active, a further WLAN-CDR is opened with an incremented Sequence Number in the WLAN. All containers, which were open when WLAN-CDR was closed, shall be re-created only when traffic for certain service data flow or rating group is detected next time.

5.2.5 Ga record transfer flows

Editor's note: It is FFS whether Ga interface is used for WLAN Direct IP Access charging.

In PDG, both fully qualified partial WLAN-CDR (FQPC) and reduced partial WLAN-CDR (RPC), as specified in 3GPP TS 32.240 [1] may be supported on the Ga interface. The support of FQPCs is mandatory and the support of RPCs is optional. For further details on the Ga protocol application refer to 3GPP TS 32.295 [54].

5.2.6 B_w CDR file transfer

Editor's note: It is FFS.

5.3 WLAN online charging scenarios

5.3.1 Basic principles

Editor's note: This clause should be moved into clause 5.1.

Editor's note: The description below doesn't allow volume based online charging.

The WLAN Direct IP Access online charging is to be based on Authentication-Authorisation (AA) Requests and quota allocation mechanism. . The AA-Requests are terminated at the home 3GPP Server. Home 3GPP Server initiates Diameter Credit Control procedures over Wo reference point as defined 3GPP TS 32.299 [50].

Editor's Note: The AA messaging based online charging mechanism would require that WLAN AN implements RADIUS prepaid extensions (only valid in figure 5.3.1.1, no Diameter prepaid extensions available in figure 5.3.1.2) or similar functionality thus imposes requirements to WLAN domain. If such requirements can not be imposed, the online charging mechanism needs to be based on the accounting requests used in offline charging. This means that reliable and credit risk free online charging can not be implemented.

Editor's Note: The Diameter AA-application selection for Wd is defined in CN4. Diameter EAP is assumed.

Editor's note: The correlation of charging information is a valid point for both, offline and online charging scenarios and should be described in the basic principles.

Editor's note: However, the procedure description below (same as in offline charging) cannot be applied in online charging (remove this note when deleting the text in deleted clause 5.3.2.1).

Online charging protocol conversions and related functionality are illustrated in figures 5.3.1.1 and 5.3.1.2.

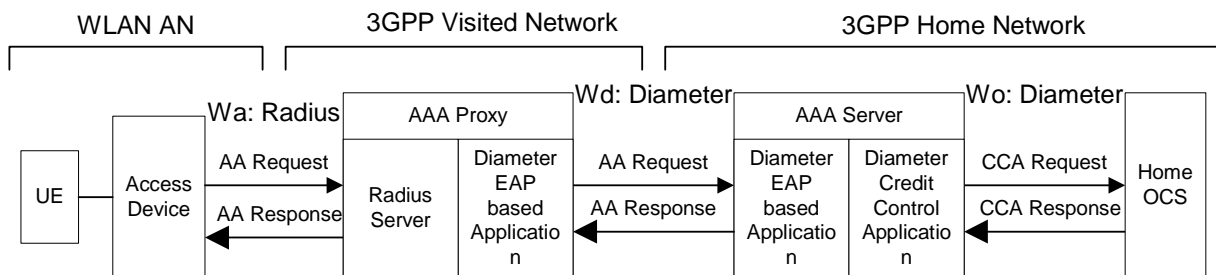

Figure 5.3.1.1: Online Charging AA-Requests - Wa based on Radius

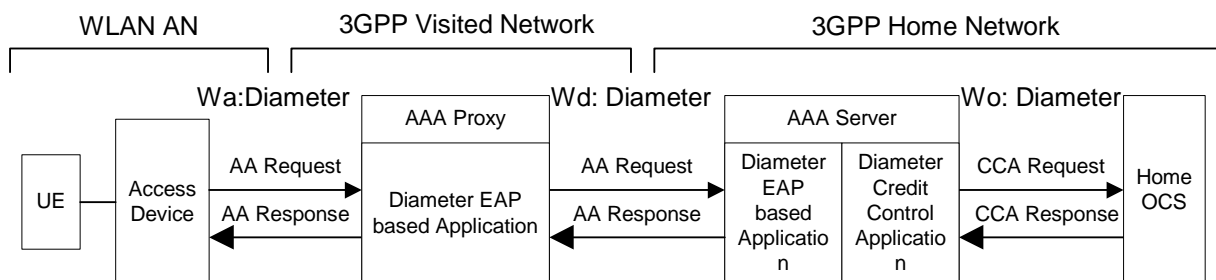

Figure 5.3.1.2: Online Charging AA-Requests - Wa based on Diameter

Editor's Note: The Diameter Credit Control Application (CCA) proposes a mechanism for Radius - NASREQ conversion. This should be clarified!

Editor's note: The figures 5.3.1.1 and 5.3.1.2 reflect not all possible protocol options.

When 3GPP IP Access is used, PDG is collecting and reporting charging data. 3GPP IP Access online charging is performed in the PDG using the common Ro based credit control application specified in 3GPP TS 32.299 [50] when the PDG is located in the HPLMN (in the non-roaming case as described in figure 4.1.2 or in the roaming case with 3GPP PS based services provided via the 3GPP home network as described in figure 4.1.3).

Access online charging is performed using Wm, Wd & Wo as described in figure 5.3.1.3 when the PDG is located in the VPLMN (in the roaming case with 3GPP PS based services provided via the 3GPP visited network as described in figure 4.1.4).

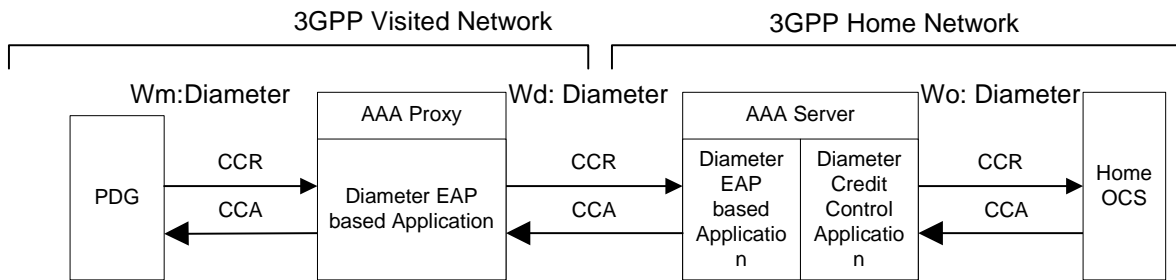

Figure 5.3.1.3: Online Charging AA-Requests from PDG – Roaming reference model - 3GPP PS based services provided via the 3GPP Visited Network

Only session based online charging (SCUR) is required in the PDG. The Credit Control Requests (CCR) and Credit Control Answers (CCA) specified for SCUR in 3GPP TS 32.299 [50] (initial/update/termination) are issued towards the OCS / received from the OCS when certain conditions (chargeable events) are met. The PDG specific contents and purpose of each of these messages, as well as the chargeable events that trigger them, are described in the following clauses.

A detailed formal description of the online charging parameters defined in the present document is to be found in 3GPP TS 32.299 [50]. Further information on the general principles of the common 3GPP online charging application can also be found in 3GPP TS 32.299 [50] and 3GPP TS 32.240 [1].

The following chargeable events are defined for PDG:

- Start of bearer. Upon encountering this event, a CCR initial, indicating the start of the bearer, is sent towards the OCS.
- Start of service data flow. If no appropriate OCS granted quota is available, a CCR update is sent towards the OCS. The service data flow is allowed only if there is granted quota, otherwise service data flow is not allowed.
- End of bearer. Upon encountering this event, a CCR termination, indicating the end of the bearer, is sent towards the OCS together with the final used units.
- Expiry of certain usage limit for the DCC session set by OCS: e.g. Validity Time or Time Quota Threshold. When this event is encountered, all current unit counts are captured and sent towards the OCS with a CCR update.
- Change of charging condition: Re-authorisation trigger is met. When this event is encountered, all current unit counts are captured and sent towards the OCS with a CCR update.
- Change of charging condition: Tariff time change. When this event is encountered, all current unit counts are captured. Sending CCR Update immediately after tariff time change is not required, see TS 32.299 [50].

Management intervention may also force trigger a chargeable event.

5.3.2 Wo message flows

The flows described in the present document specify the charging communications between WLAN access network and the OCS for different charging scenarios.

5.3.2.1 Message Flows - WLAN session were WLAN access network support Diameter Credit Control

Figure 5.3.2.1 shows the Diameter transactions that are required between 3GPP AAA server and OCS during a WLAN session were the WLAN access network support Diameter Credit Control Application.

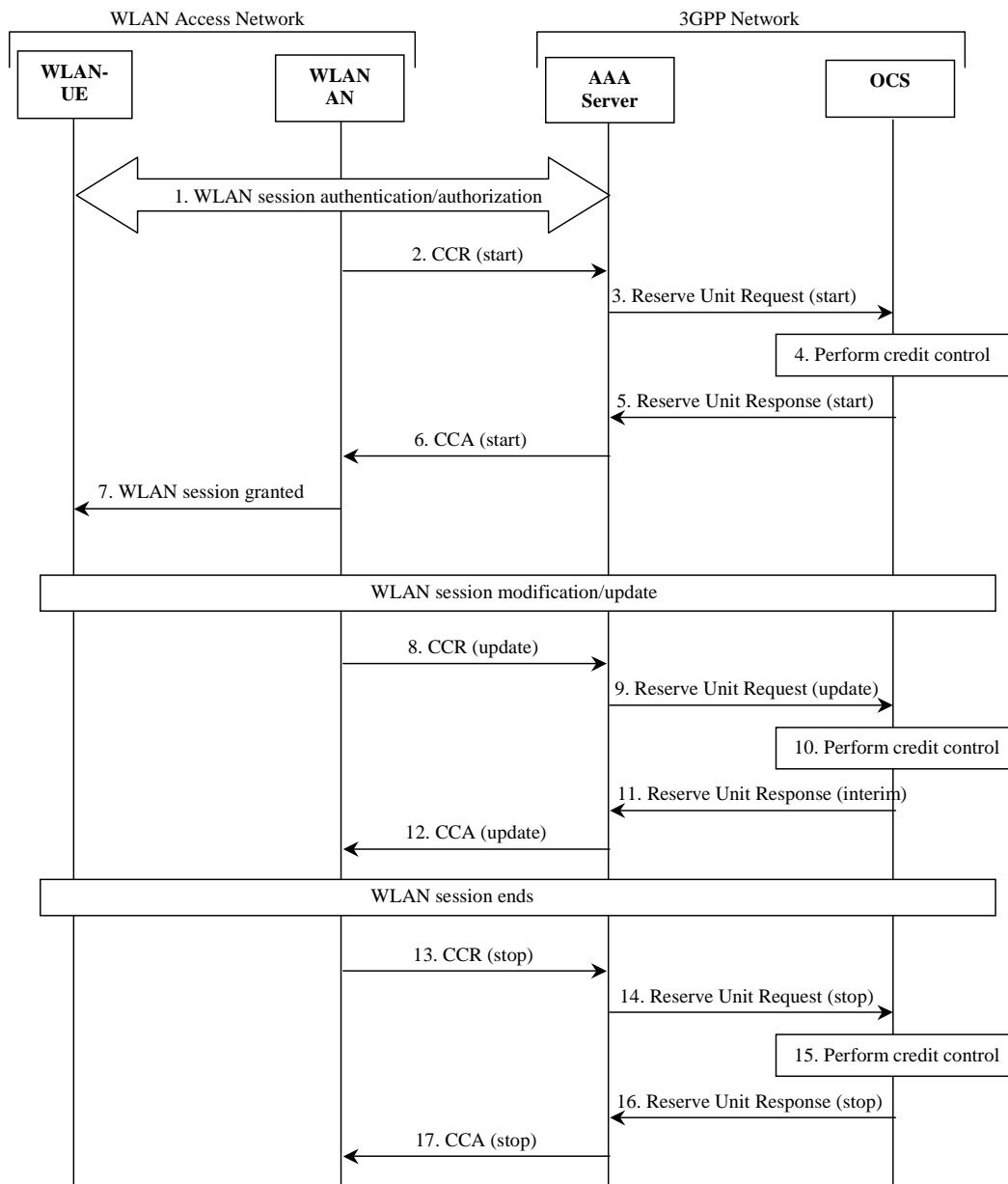

Figure 5.3.2.1: Message Sequence Chart for WLAN session when WLAN AN support DCC

1. The WLAN UE request a WLAN session.
2. The WLAN access networks starts a Diameter Credit Control session with the 3GPP AAA server.
3. The 3GPP AAA starts a Reserve Unit session with OCS based on the Credit Control Request.
4. OCS performs credit control (rating/reservation of quota).

5. OCS replies with a Reserve Unit Response with a quota (if granted by OCS).
6. 3GPP AAA replies to the WLAN access network with a CCA.
7. If OCS granted quota then WLAN access network will grant the WLAN session.
8. When the quota has expired then WLAN access network send a new CCR for reserving more quota to 3GPP AAA server.
9. The 3GPP AAA sends a Reserve Unit Request message, based on the Credit Control Request, to OCS.
10. OCS performs credit control (rating/reservation of quota).
11. OCS replies with a Reserve Unit Response with a quota (if granted by OCS).
12. 3GPP AAA replies to the WLAN access network with a CCA.
13. When the WLAN session ends, then WLAN access network send a CCR (stop) to the 3GPP AAA server.
14. The 3GPP AAA sends a Reserve Unit Request message, based on the Credit Control Request, to OCS.
15. OCS performs credit control (updates the account/return back unused quota).
16. OCS replies with a Reserve Unit Response.
17. 3GPP AAA replies to the WLAN access network with a CCA.

NOTE: There can be more than one DCC update transactions within a WLAN session. OCS defines the update report interval depending on the reserved quota.

5.3.2.2 Message Flows - WLAN session were WLAN access network support RADIUS/Diameter accounting (version 1)

Figure 5.3.2.2 shows the Diameter transactions that are required between 3GPP AAA server and OCS during a WLAN session were the WLAN access network support RADIUS/Diameter Accounting.

- NOTE 1: the 3GPP AAA server always has a possibility to stop a WLAN session based on requirements on the Wa interface. This functionality can be useful in an online charging case when the user is running out of credit.
- NOTE 2: The proposed solution must be further investigated if session timeout can be handled in this way or if it must be art of the authentication/authorization command.
- NOTE 3: This solution only support credit control when charging is based on time. Charging based on volume is also possible, but credit control will not be fully possible. The credit risk can be decreased if short time reservations are used.

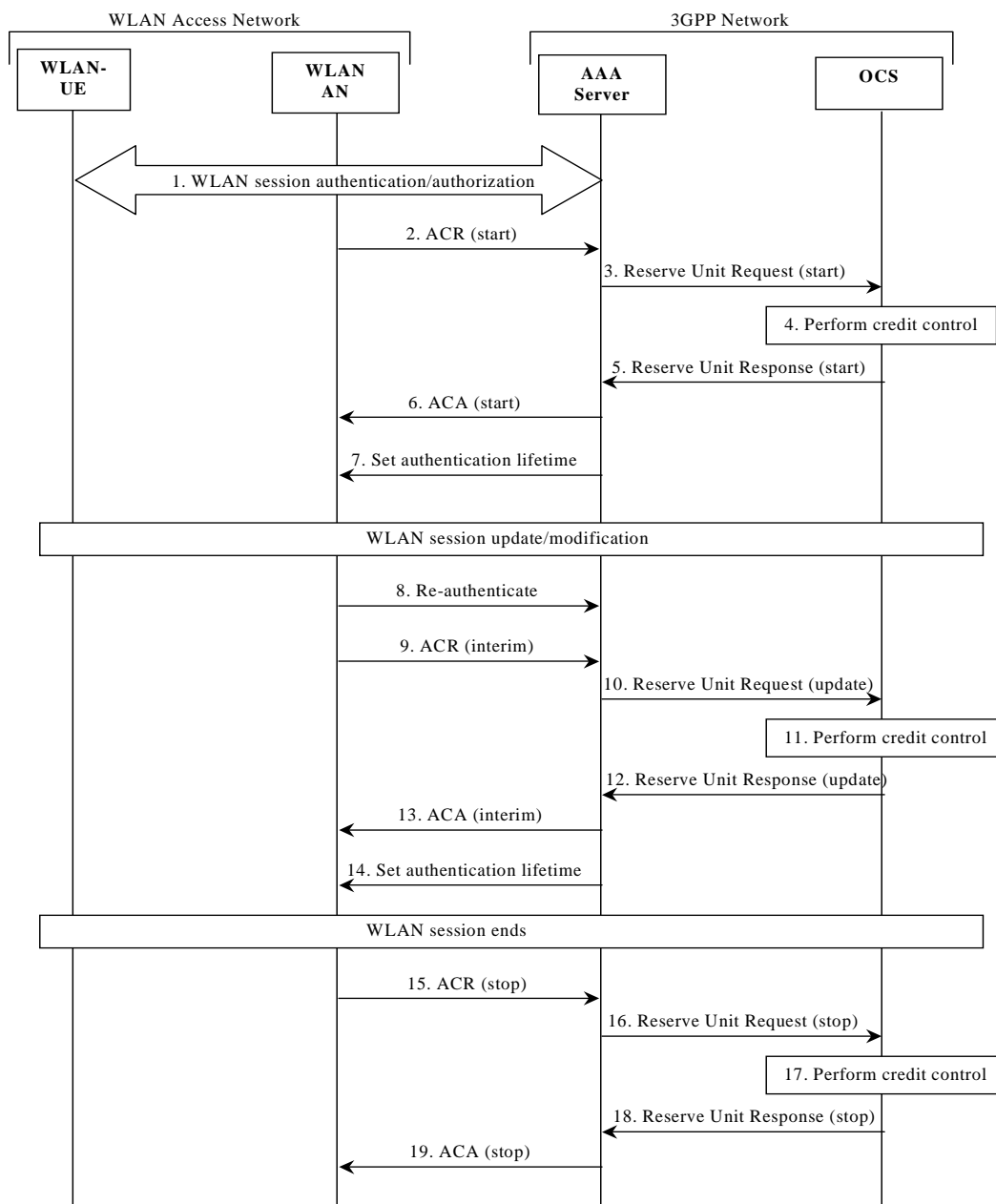

Figure 5.3.2.2: Message Sequence Chart for WLAN session when WLAN AN support Accounting

- 1. The WLAN UE request a WLAN session.

2. The WLAN access networks starts an accounting session with the 3GPP AAA server.
3. The 3GPP AAA initiates a Reserve Unit Request message to OCS.
4. OCS performs credit control (rating/reservation of quota).
5. OCS replies with a Reserve Unit Response with a quota (if granted by OCS).
6. 3GPP AAA server acknowledges the accounting session to WLAN access network.
7. 3GPP AAA server set the session timeout (and termination action to new request) for the WLAN session based on the time quota assigned by OCS.
8. WLAN access network re-authenticates when the timeout has expired.
9. WLAN access network also send an interim ACA to 3GPP AAA server.
10. Based in the ACA and re-authentication messages, AAA server prepares a new Reserve Unit Request and sends it to OCS.
11. OCS performs credit control (rating/reservation of quota).
12. OCS replies with a Reserve Unit Response with a quota (if granted by OCS).
13. 3GPP AAA server acknowledges the accounting session to WLAN access network.
14. 3GPP AAA server set the session timeout (and termination action to new request) for the WLAN session based on the time quota assigned by OCS.
15. When the WLAN session ends, then WLAN access network send a ACR (stop) to the 3GPP AAA server.
16. The 3GPP AAA server prepares a Reserve Unit Request message with information from the ACR and sends it to OCS.
17. OCS performs credit control (updates the account/return back unused quota).
18. OCS replies with a Reserve Unit Response message as acknowledgement.
19. 3GPP AAA server acknowledges the accounting session with an ACA.

NOTE: There can be more then one Reserve Unit update transactions within a WLAN session. OCS defines the interim report interval depending on the reserved quota.

5.3.2.3 Message Flows - WLAN session were WLAN access network support RADIUS/Diameter accounting (version 2)

Figure 5.3.2.3 shows the Diameter transactions that are required between 3GPP AAA server and OCS during a WLAN session were the WLAN access network support RADIUS/Diameter Accounting.

NOTE 1: The 3GPP AAA server always has a possibility to stop a WLAN session based on requirements on the Wa interface. This functionality can be useful in an online charging case when the user is running out of credit.

NOTE 2: This solution only support credit control when charging is based on time. Charging based on volume is also possible, but credit control will not be fully possible. The credit risk can be decreased if short time reservations are used.

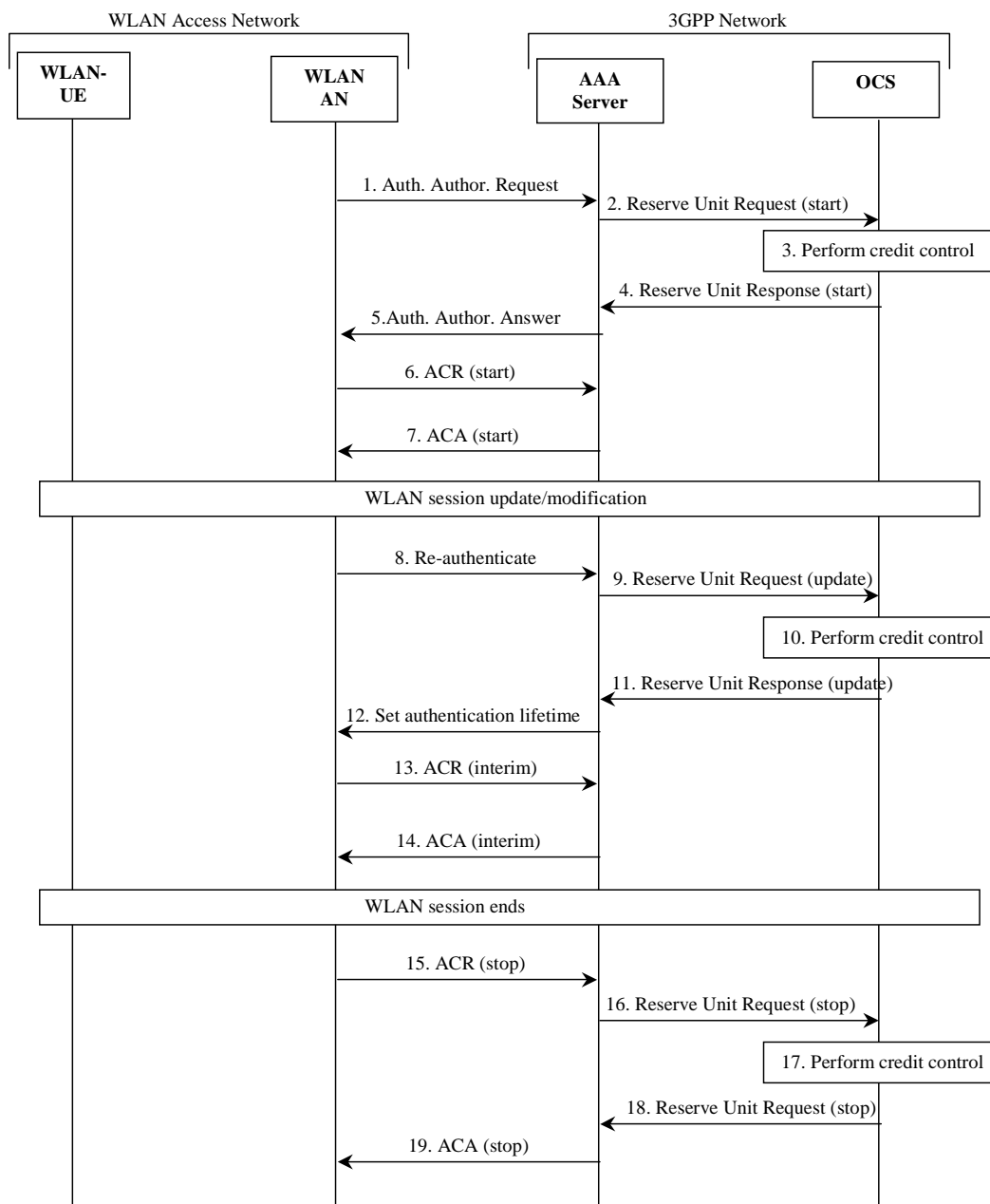

Figure 5.3.2.3: Message Sequence Chart for WLAN session when WLAN AN support Accounting

1. The WLAN access networks starts authentication/authorization with the 3GPP AAA server.
2. The 3GPP AAA initiates a Reserve Unit Request to OCS.

3. OCS performs credit control (rating/reservation of quota).
4. OCS replies with a Reserve Unit Response with a quota (if granted by OCS).
5. 3GPP AAA server responds to the WLAN access network for authentication/authorization with a session timeout (and termination action to new request) based on the reserved quota.
6. WLAN access network starts an accounting session.
7. 3GPP AAA servers acknowledge the accounting message.
8. WLAN access network re-authenticates when the timeout has expired.
9. Based on the re-authentication messages, AAA server prepares a new Reserve Unit Request message and sends it to OCS.
10. OCS performs credit control (rating/reservation of quota).
11. OCS replies with a Reserve Unit Response message with a quota (if granted by OCS).
12. 3GPP AAA server responds to the WLAN access network for authentication/authorization with a session timeout (and termination action to new request) based on the reserved quota.
13. WLAN access network sends an accounting interim report to 3GPP AAA server.
14. 3GPP AAA servers acknowledge the accounting message.
15. When the WLAN session ends, then WLAN access network send an ACR (stop) to the 3GPP AAA server.
16. The 3GPP AAA server prepares a Reserve Unit Request message with information from the ACR and sends it to OCS.
17. OCS performs credit control (updates the account/return back unused quota).
18. OCS replies with a Reserve Unit Response message as acknowledgement.
19. 3GPP AAA server acknowledges the accounting session with an ACA.

NOTE: There can be more than one Reserve Unit update transactions within a WLAN session. OCS defines the interim report interval depending on the reserved quota.

5.3.2.4 Message Flows - WLAN session were WLAN access network don't support RADIUS/Diameter accounting

Figure 5.3.2.4 shows the Diameter transactions that are required between 3GPP AAA server and OCS during a WLAN session were the WLAN access network don't support RADIUS/Diameter Accounting.

NOTE 1: This solution only support online charging when the charging model is based on time. The WLAN user can be over charged because 3GPP AAA server and OCS will never know when the WLAN session ends. OCS will stop change when the last re-authentication timeout has expired.

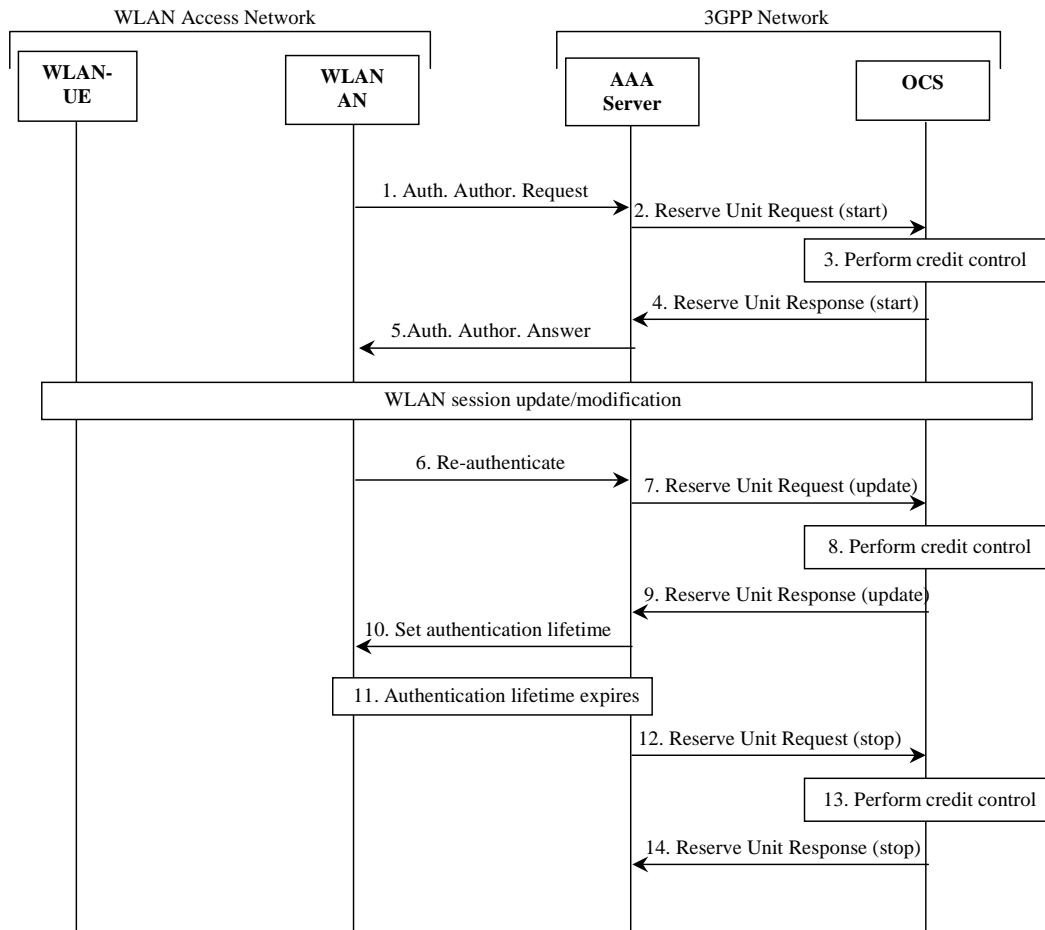

Figure 5.3.2.4: Message Sequence Chart for WLAN session when WLAN AN do not support Accounting

1. The WLAN access networks starts authentication/authorization with the 3GPP AAA server.
2. The 3GPP AAA initiates a Reserve Unit Request to OCS.
3. OCS performs credit control (rating/reservation of quota).
4. OCS replies with a Reserve Unit Response message with a quota (if granted by OCS).
5. 3GPP AAA server responses to the WLAN access network for authentication/authorization with a session timeout (and termination action to new request) based on the reserved quota.
6. WLAN access network re-authenticates when the timeout has expired.
7. Based on the re-authentication messages, AAA server prepares a new Reserve Unit Request and sends it to OCS.
8. OCS performs credit control (rating/reservation of quota).
9. OCS replies with a Reserve Unit Response with a quota (if granted by OCS).

10. 3GPP AAA server responds to the WLAN access network for authentication/authorization with a new session timeout (and termination action to new request) based on the reserved quota.
11. When the authentication timeout expires and new re-authentication has been performed, then the WLAN session will be handled as closed.
12. The 3GPP AAA server prepares a Reserve Unit Request (stop), with used units as the authentication timeout, and sends it to OCS.
13. OCS performs credit control (updates the account/return back unused quota).
14. OCS replies with a Reserve Unit Response as acknowledgement.

NOTE 2: There can be more than one interim DCC transactions within a WLAN session. OCS defines the interim report interval depending on the reserved quota.

NOTE 3: To be sure that the WLAN session ends when the Authentication Lifetime expires, the 3GPP AAA server can stop the session over the Wa interface.

Editor's Note: Add flow for PDG - OCS.

6 Definition of charging information

6.1 Data description for WLAN offline charging

6.1.1 Rf message contents

The WLAN nodes generate accounting information that can be transferred from the CTF to the CDF. For this purpose, WLAN offline charging utilises the *Charging Data Transfer* operation that is specified in the 3GPP accounting application in 3GPP TS 32.299 [50].

6.1.1.1 WLAN Direct IP Access Charging message contents

The accounting message contents at Wa and Wd reference points are specified in 3GPP TS 29.234 [204].

The accounting information exchanged on the interface (Wf reference point) shall be the same as specified in 3GPP TS 32.299 [50] (reference point Rf). The Wf reference point shall transport the accounting Information Elements arriving over the Wa/Wd reference point. If the Wa/Wd reference point is RADIUS based, the RADIUS accounting messages and Information Elements shall be translated to Diameter accounting messages AVPs as defined in RFC 3588 [401] and in RFC 4005 [404]. If Wa/Wd reference point is Diameter incoming messages shall be passed on.

Editor's Note: When Wf interface is based on the Rf interface, it is FFS if there is a need for Diameter - Diameter translation. Alternatively, Wf could be based on Wa/Wd.

The *Charging Data Transfer* operation employs the *Charging Data Request* and *Charging Data Response* messages. Table 6.1.1.1 describes the use of these messages in WLAN direct IP access offline charging.

Table 6.1.1.1: Offline Charging Messages Reference Table

Message	Source	Destination
<i>Charging Data Request</i>	WLAN AN	CDF
<i>Charging Data Response</i>	CDF	WLAN AN

6.1.1.1.1 Charging Data Request Message

Table 6.1.1.1.1 illustrates the basic structure of the *Charging Data Request* message as used for WLAN direct IP access offline charging.

Table 6.1.1.1.1: Charging Data Request Message Contents

Field	Category	Description
Session Identifier	M	This field identifies the operation session.
Originator Node-Id	M	This field contains the identification of the source point of the operation and the realm of the operation originator.
Originator Domain	M	This field contains the realm of the operation originator.
Operation Type	M	This field defines the transfer type: event for event based charging and start, interim, stop for session based charging.
Operation Number	M	This field contains the sequence number of the transferred messages.
Operation Token	O _M	This field identifies the domain, subsystem or service and release.
Service Information	O _M	This field holds the 3GPP specific WLAN parameter.

6.1.1.1.2 Charging Data Response Message

Table 6.1.1.1.2 illustrates the basic structure of a *Charging Data Response* message as used for WLAN direct IP access offline charging.

Table 6.1.1.1.2: Charging Data Response Message

Field	Category	Description
Session Identifier	M	This field identifies the operation session.
Result		

6.1.2 GTP' message contents

GTP' is used between CDF and CGF on Wz reference point.

Editor's note: more description needed

6.1.3 CDR Description on the Bw Interface

Dedicated types of CDRs can be generated in the service domain for WLAN by the WLAN AN/PDG/AAA Servers. The content of each CDR type is defined in one of the tables that are part of this clause. For each CDR type the parameter definition includes the parameter name, description and category.

6.1.3.1 CDR Field Types

The following Standard CDR content and format are considered:

- WLAN-AN-CDR generated based on information from the WLAN AN handled by 3GPP AAA Server.
- WLAN-PDG-CDR generated based on information from the PDG.

The content of each CDR type is defined in the tables 6.1.3.2.1 and 6.1.3.2.2. For each CDR type the field definition includes the field name, category and description. The CDF provides the CDRs at the Bw interface in the format and encoding described in 3GPP TS 32.298 [51]. Additional CDR formats and contents may be available at the interface to the billing system to meet the requirements of the billing system, these are outside of the scope of 3GPP standardisation.

6.1.3.2 CDR Content

Editor's Note: Contents of the CDRs are for further study.

6.1.3.2.1 WLAN Direct IP Access CDR (WLAN-AN-CDR)

NOTE: This CDR should contain a WLAN-Radio-Container as defined in "WLAN Information".

Table 6.1.3.2.1 WLAN Direct IP Access CDR (WLAN-AN-CDR)

Field	Category	Description
Record Type	M	WLAN Direct IP Access CDR
Record Sequence Number	C	Partial record sequence number. Only present in case of partial records
Served IMSI	M	IMSI of the served party
Served IMEI	C	The IMEI of the ME, if available
Operator Name	M	Hot Spot Operator Name as defined in draft-ietf-geopriv-radius-lo-04 [405]
Location Information	C	Location information regarding the hotspot operator as defined in draft-ietf-geopriv-radius-lo-04 [405]
Location Type	C	
Charging ID	M	Accounting Session-ID from WLAN AN
NAS Port	C	NAS Port of WLAN AN
NAS Port-Id	C	NAS Port-Id of WLAN AN
NAS Port Type	C	NAS-Port-Type of WLAN AN
NAS-IP address	C	IPv4 address of the hot-spot
NAS-Ipv6 address	C	IPv6 address of the hot-spot
Local IP Address	O _C	Local IP address of the served IMSI, i.e. IPv4 or IPv6
Data Volume Downlink	C	Downlink data volume for WLAN UE
Data Volume Uplink	C	Uplink data volume for WLAN UE
Record Opening Time	M	Time stamp when WLAN session is activated or record opening time on subsequent partial records
Local Record Sequence Number	O _M	Consecutive record number created by this node. The number is allocated sequentially including all CDR types
Duration	M	Duration of this record
Cause for Record Closing	M	The reason for closure of the record
Node ID	O _M	Name of the recording entity
Service Context Id	O _M	Holds the context information to which the CDR belongs. The information is obtained from the Operation Token of the Charging Data Request message
Record Extensions	O _C	A set of network operator/manufacturer specific extensions to the record Conditioned upon the existence of an extension

6.1.3.2.2 WLAN 3GPP IP Access charging message contents

The content of WLAN 3GPP IP Access CDR is defined in the table 6.1.3.2.2. The field definition includes the field name, category and description. The detailed field descriptions are provided in 3GPP TS 32.298 [51].

If the collection of CDR data is enabled then the PDG shall make available the following data available for each WLAN 3GPP IP Access connection.

Table 6.1.3.2.2 : Wz interface CDR content (WLAN-CDR)

Field	Category	Description
Record Type	M	WLAN PDG record.
Served IMSI	M	IMSI of the served party.
Served MSISDN	O _M	The primary MSISDN of the subscriber.
PDG Address used	M	IP address of the PDG used.
Node ID	O _M	Name of the recording entity.
Serving WAG Address	M	Serving WAG address used during this record.
WAG PLMN Identifier	O _M	WAG PLMN Identifier (MCC and MNC) used during this record.
Serving AAA Server/proxy Address	M	Serving AAA Server/Proxy address.
WLAN UE remote IP address	O _C	
WLAN UE Local IP address	O _C	
Charging ID	M	PDG identifier used to correlate WLAN AN generated information to PDG generated information
WLAN session id	M	WLAN session identifier used to correlate WLAN AN generated information to PDG generated information
Access Point Name Network Identifier	O _M	The logical name of the connected access point to the external packet data network (network identifier part of APN).
Charging Characteristics?	M	The Charging Characteristics applied to the PDP context.?
Charging Characteristics Selection Mode?	O _M	Holds information about how Charging Characteristics were selected.
Record Opening Time	M	Time stamp when End-to-end Tunnel is activated in this PDG? or record opening time on subsequent partial records.
Duration	M	Duration of this record in the PDG.
Cause for Record Closing	M	The reason for the release of record from this PDG.
Record Sequence Number	C	Partial record sequence number, only present in case of partial records.
Local Record Sequence Number	O _M	Consecutive record number created by this node. The number is allocated sequentially including all CDR types.
Diagnostics	O _M	A more detailed reason for the release of the connection.
Record Extensions	O _C	A set of network operator/manufacturer specific extensions to the record. Conditioned upon the existence of an extension.

6.2 Data description for WLAN online charging

Editor's Note: To be completed

6.2.1 Ro message contents

6.2.1.1 WLAN Direct IP Access Charging message contents

The WLAN nodes generate debit/reserve unit information that can be transferred from the CTF to the OCF. For this purpose, WLAN online charging utilises the *Debit Unit and Reserve Unit* procedure that is specified in the 3GPP credit control application in 3GPP TS 32.299 [50].

The *Debit/Reserve Unit* procedure employs the *Debit/Reserve Unit Request* and *Debit/Reserve Unit Response* messages. Table 6.2.1.1 describes the use of these messages in WLAN Direct IP Access online charging.

Table 6.2.1.1: Online Charging Messages Reference Table

Command-Name	Source	Destination
Debit/Reserve Unit Request	3GPP AAA Server	OCS
Debit/Reserve Unit Response	OCS	3GPP AAA Server

6.2.1.1.1 Debit/Reserve Unit Request message

Table 6.2.1.1.1 illustrates the basic structure of the *Debit/Reserve Unit Request* message as used for WLAN direct IP access online charging.

Table 6.2.1.1.1: Debit/Reserve Units Request Content

Debit/Reserve Units Request	Category	Description
Session Identifier	M	This field identifies the operation session.
Originator Node-Id	M	This field contains the identification of the source point of the operation.
Originator Domain	M	This field contains the realm of the operation originator.
Operation Token	M	This field is a unique operation identifier.
Operation Type	M	This field defines the transfer type: event for event based charging and start, interim, stop for session based charging.
Operation Number	M	This field contains the sequence number of the transferred messages.
Subscriber Address	O _C	This field contains the identification of the mobile subscriber (i.e. MSISDN) that uses the requested service.
Service Token	O _C	This field is a unique service identifier.
Cause of Termination	O _C	This field contains the termination reason of the service.
Service Units Requested	O _C	This field contains the amount of requested service units.
Service Units Used	O _C	This field contains the amount of used service units.
Multiple Operation	O _C	This field indicate the occurrence of multiple operations.
Multiple Unit Operation	O _C	This field contains the parameter for the quota management.
Subscriber Equipment Number	O _C	This field contains the identification of the mobile device (i.e. IMEI) that uses the subscriber.
Service Information	O _M	This field holds additional 3GPP service specific parameter: <ul style="list-style-type: none"> - PS Information; - WLAN Information; - IMS Information; - LCS Information; - PoC Information; - MBMS Information.

6.2.1.1.2 Debit/Reserve Unit Response message

Table 6.2.1.1.2 illustrates the basic structure of the *Debit/Reserve Unit Response* message as used for WLAN direct IP access online charging.

Table 6.2.1.1.2: Debit/Reserve Units Response Content

Debit/ Reserve Units Response	Category	Description
Session Identifier	M	This field identifies the operation session.
Operation Result	M	This field identifies the result of the operation.
Originator Node-Id	M	This field contains the identification of the source point of the operation.
Originator Domain	M	This field contains the realm of the operation originator.
Operation Type	M	This field defines the transfer type: event for event based charging and start, interim, stop for session based charging.
Operation Number	M	This field contains the sequence number of the transferred messages.
Service Units Granted	O _C	This field contains the amount of used service units.
Unit Validity Time	O _C	This field contains the time for the validity of the granted service units.
Extended Information	O _C	This field holds the 3GPP specific information.

6.2.1.2 WLAN 3GPP IP Access Charging message contents

The *Debit/Reserve Unit* procedure employs the *Debit/Reserve Unit Request* and *Debit/Reserve Unit Response* messages. Table 6.2.1.2 describes the use of these messages in WLAN 3GPP IP Access online charging.

Table 6.2.1.2 Online Charging Messages Reference Table

Command-Name	Source	Destination
Debit/Reserve Unit Request	PDG/3GPP AAA Server	OCS
Debit/Reserve Unit Response	OCS	PDG/3GPP AAA Server

6.2.1.2.1 Debit/Reserve Unit Request message

Table 6.2.1.2.1 illustrates the basic structure of the *Debit/Reserve Unit Request* message as used for WLAN 3GPP IP access online charging.

Table 6.2.1.2.1 Debit/Reserve Units Request Content

Debit/Reserve Units Request	Category	Description
Session Identifier	M	This field identifies the operation session.
Originator Node-Id	M	This field contains the identification of the source point of the operation.
Originator Domain	M	This field contains the realm of the operation originator.
Operation Token	M	This field is a unique operation identifier.
Operation Type	M	This field defines the transfer type: event for event based charging and start, interim, stop for session based charging.
Operation Number	M	This field contains the sequence number of the transferred messages.
Subscriber Address	O _C	This field contains the identification of the mobile subscriber (i.e. MSISDN) that uses the requested service.
Service Token	O _C	This field is a unique service identifier.
Cause of Termination	O _C	This field contains the termination reason of the service.
Service Units Requested	O _C	This field contains the amount of requested service units.
Service Units Used	O _C	This field contains the amount of used service units.
Multiple Operation	O _C	This field indicate the occurrence of multiple operations.
Multiple Unit Operation	O _C	This field contains the parameter for the quota management.
Subscriber Equipment Number	O _C	This field contains the identification of the mobile device (i.e. IMEI) that uses the subscriber.
Service Information	O _M	This field holds additional 3GPP service specific parameter: <ul style="list-style-type: none"> - PS Information; - WLAN Information; - IMS Information; - LCS Information; - PoC Information; - MBMS Information.

6.2.1.2.2 Debit/Reserve Unit Response message

Table 6.2.1.2.2 illustrates the basic structure of the *Debit/Reserve Unit Response* message as used for WLAN 3GPP IP access online charging.

Table 6.2.1.2.2 Debit/Reserve Units Response Content

Debit/ Reserve Units Response	Category	Description
Session Identifier	M	This field identifies the operation session.
Operation Result	M	This field identifies the result of the operation.
Originator Node-Id	M	This field contains the identification of the source point of the operation.
Originator Domain	M	This field contains the realm of the operation originator.
Operation Type	M	This field defines the transfer type: event for event based charging and start, interim, stop for session based charging.
Operation Number	M	This field contains the sequence number of the transferred messages.
Service Units Granted	O _C	This field contains the amount of used service units.
Unit Validity Time	O _C	This field contains the time for the validity of the granted service units.
Extended Information	O _C	This field holds the 3GPP specific information.

6.2.2 Detailed Message Formats

FFS.

6.2.2.1 WLAN Direct IP Access Charging message contents

FFS.

6.2.2.2 WLAN 3GPP IP Access Charging message contents

FFS.

6.3 WLAN Charging specific parameters

The WLAN-Information parameter used for WLAN online charging is provided in the Service-Information parameter.

6.3.1.1 WLAN charging information assignment for Service-Information

The components in the Service-Information that are use for WLAN charging can be found in table 6.3.1.1.

Table 6.3.1.1: Service-Information used for WLAN Charging

Field	Category	Description
Service-Information	O _M	This is a structured field and holds the 3GPP specific parameter as defined in 3GPP TS 32.299 [50]. For WLAN Charging the WLAN-Information is used.
WLAN-Information	O _M	This is a structured field and holds the WLAN specific parameters. The details are defined in clause 6.3.1.2.

6.3.1.2 Definition of WLAN Information

WLAN specific charging information is provided within the WLAN-Information. The fields of the WLAN-Information which are different covered in several WLAN network notes are indicated by the note specific type.

The detailed structure of the WLAN-Information parameter can be found in table 6.3.1.2.

Table 6.3.1.2 Structure of the WLAN-Information

Field	Category	Description
PDG-Charging-Id	O _C	TBD
WLAN-Session-Id	O _C	TBD
PDG-Address	O _C	TBD
PDG-IPv6-Address	O _C	TBD
WAG-Address	O _C	TBD
WAG-IPv6-Address	O _C	TBD
WAG-PLMN-Id	O _C	TBD
AAA-Server/Proxy-Address	O _C	TBD
AAA-Server/Proxy-Ipv6-Address	O _C	TBD
Framed-IP-Address	O _C	TBD
Framed-IPv6-Prefix	O _C	TBD
WLAN-UE-Local-IP-Address	O _C	TBD
WLAN-UE-Local-Ipv6-Address	O _C	TBD
3GPP-CG-Address	O _C	TBD
3GPP-CG-IPv6-Address	O _C	TBD
Called-Station-Id (note 1)	O _C	TBD
3GPP-Session-Stop-Indicator	O _C	TBD
3GPP-Charging-Characteristics	O _C	TBD
Charging-Rule-Base-Name	O _C	TBD
WLAN-Radio-Container	O _C	TBD
Operator-Name	O _C	TBD
Location-Type	O _C	TBD
Location-Information	O _C	TBD
WLAN-Technology	O _C	TBD

NOTE: This field contains the identifier of the access point (APN) the user is connected to
 Editor's Note: The 'operatorName', 'locationName' and 'locationInformation' fields are defined in 3GPP TS 29.234 [204].

6.3.2 Formal WLAN charging parameter description

6.3.2.1 WLAN charging information for CDRs

The detailed definitions, abstract syntax and encoding of the WLAN CDR parameters are specified in TS 32.298 [51].

6.3.2.2 Definition of the WLAN charging events

The detailed event parameter definitions are specified in TS 32.299 [50].

Annex A (informative): Bibliography

a) The 3GPP charging specifications

- 3GPP TS 32.250: "Telecommunication management; Charging management; Circuit Switched (CS) domain charging".
- 3GPP TS 32.251: "Telecommunication management; Charging management; Packet Switched (PS) domain charging".
- 3GPP TS 32.260: "Telecommunication management; Charging management; IP Multimedia Subsystem (IMS) charging".
- 3GPP TS 32.270: "Telecommunication management; Charging management; Multimedia Messaging Service (MMS) charging".
- 3GPP TS 32.271: "Telecommunication management; Charging management; Location Services (LCS) charging".
- 3GPP TS 32.296: "Telecommunication management; Charging management; Online Charging System (OCS): Applications and interfaces".

b) Other charging specifications

- ITU-T Recommendation D.93: "Charging and accounting in the international land mobile telephone service (provided via cellular radio systems)".

c) Common 3GPP specifications

- 3GPP TS 22.101: "Service aspects; Service principles".
- 3GPP TS 22.115: "Service aspects; Charging and billing".
- 3GPP TS 23.002: "Network architecture".
- 3GPP TS 23.003: "Numbering, addressing and identification".
- 3GPP TS 27.001: "General on Terminal Adaptation Functions (TAF) for Mobile Stations (MS)".

d) other Domain and Service specific 3GPP / ETSI specifications

- 3GPP TR 23.934: "3GPP system to Wireless Local Area Network (WLAN) interworking; Functional and architectural definition".
- 3GPP TS 24.234: "3GPP System to Wireless Local Area Network (WLAN) interworking; User Equipment (UE) to network protocols; Stage 3".

e) Relevant ITU Recommendations

- ITU-T Recommendation D.93: "Charging and accounting in the international land mobile telephone service (provided via cellular radio systems)".
- ITU-T Recommendation E.164: "The international public telecommunication numbering plan".
- ITU-T Recommendation Q.767: "Application of the ISDN user part of CCITT signalling System No.7 for international ISDN interconnections".
- ITU-T Recommendation X.25: "Interface between Data Terminal Equipment (DTE) and Data Circuit-terminating Equipment (DCE) for terminals operating in the packet mode and connected to public data networks by dedicated circuit".
- ITU-T Recommendation X.121: "International numbering plan for public data networks".

f) Relevant IETF RFCs

- IETF RFC 959 (1985): "File Transfer Protocol".
- IETF RFC 783: "Trivial File Transfer Protocol (TFTP)".

Annex B (normative): Re-using the GGSN charging functions to implement the PDG charging functions

This annex does not introduce new charging requirements for the Packet Data Gateway (PDG).

B.1 General

3GPP TS 23.234 [201] depicts a PDG implementation that re-uses GGSN functionality. Existing GGSN deployments may be re-used to implement the PDG functionality via using a subset of the Gn reference point (Gn'). A Tunnel Termination Gateway (TTG) is used to cover all aspects of the PDG that are not covered by the GGSN. In such implementation, the GGSN charging gateway interfaces are used to provide charging gateway interfaces of the PDG. The following figure depicts a PDG implementation that re-uses GGSN charging functionality. The Ga reference point between the GGSN and the CGF is used to transfer offline charging records from the PDG CDF to the CGF (Wz reference point). The Gy reference point between the GGSN and the OCS is used to transfer online charging messages between the PDG CTF and the OCS (Wy reference point).

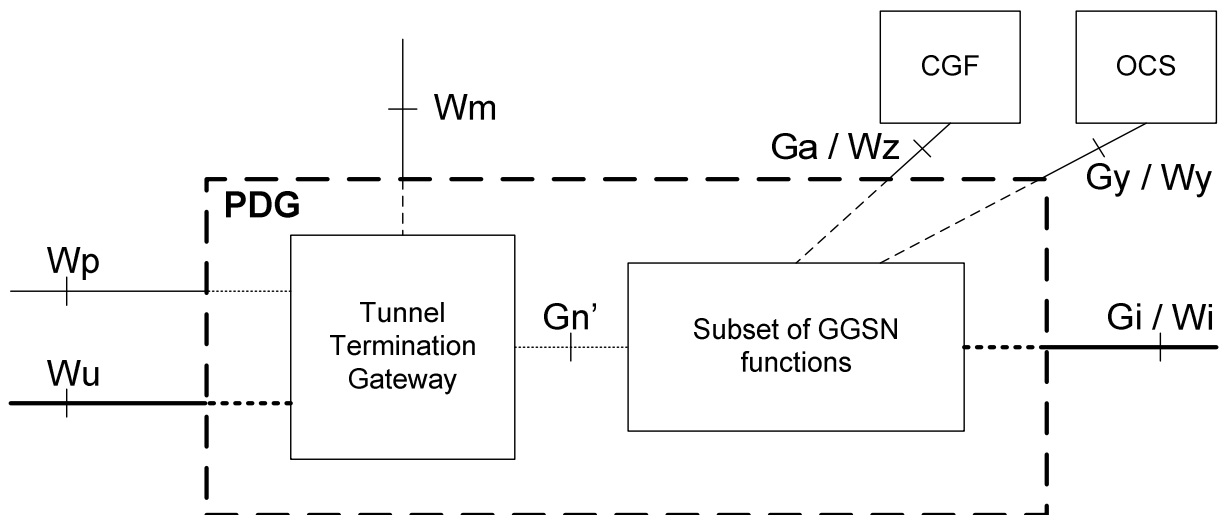

Figure B.1: PDG implementation re-using GGSN charging functionality

B.2 No re-use of policy control in the GGSN

The end-to-end tunnel between the WLAN UE and the PDG is setup according to the procedure described in 3GPP TS 23.234 [208]. In a configuration when the Gn' reference point is used, the end-to-end tunnel setup between the WLAN UE and the PDG is terminated by the TTG of the PDG, and the setup of GTP tunnel(s) is triggered towards the GGSN part of the PDG. In such configuration, end-to-end tunnel is mapped one-to-one to a GTP tunnel, as illustrated in the figure B.2.

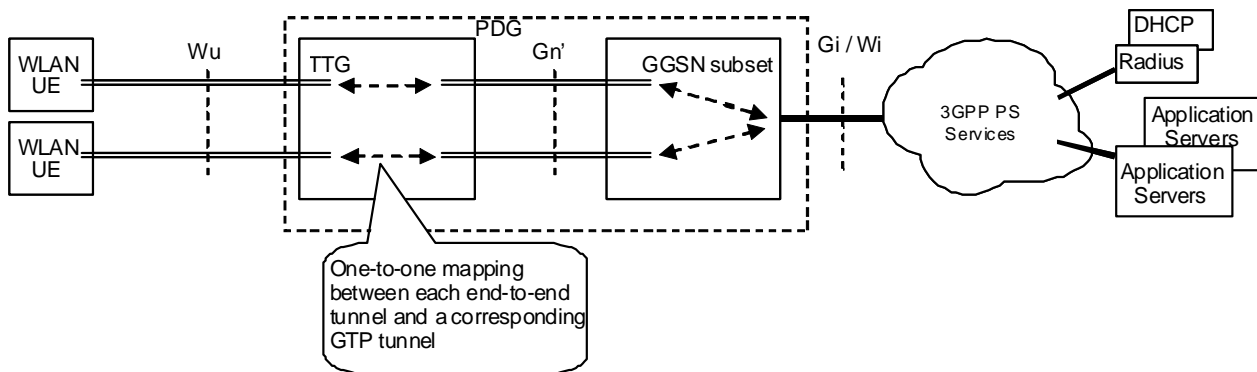

Figure B.2: Mapping between end-to-end tunnel and single GTP tunnel

NOTE: When the policy control in the GGSN is used, the mapping between end-to-end and GTP tunnel may not be one-to-one. This configuration is FFS.

B.2.1 Offline charging

In this configuration, the GGSN collects charging data related to the PDP contexts in the G-CDR, as described in the Rel-7 GGSN charging (3GPP TS 32.251 [2]). Charging information for WLAN 3GPP IP access (WLAN CDR) shall be collected by the GGSN in the G-CDR according to the following mapping table:

Table B.2.1.1 : Mapping between WLAN CDR and G-CDR fields

G-CDR field	G-CDR Category	WLAN-CDR mapping guidance
Record Type	M	Record Type
Network initiated PDP context	O _C	<i>Not applicable in this 3GPP release</i>
Served IMSI	M	Served IMSI
Served IMEISV	O _C	<i>Not applicable in this 3GPP 3GPP release</i>
GGSN Address used	M	PDG Address used
Charging ID	M	Charging ID
SGSN Address	M	Serving WAG address
Access Point Name Network Identifier	O _M	Access Point Name Network Identifier
PDP Type	O _M	<i>Not applicable in this release</i>
Served PDP Address	O _C	WLAN UE remote IP address
Dynamic Address Flag	O _C	<i>Not applicable in this 3GPP release</i>
List of Traffic Data Volumes	O _M	<i>Can be used to record the data volume of the PDP context, which should be equivalent to the volume of the end-to-end tunnel. NOTE: In case of I-WLAN mobility architecture and HA co-located with GGSN, the volume shall be collected as if it was collected by the HA.</i>
Record Opening Time	M	Record Opening Time
MS Time Zone	O _C	<i>Not applicable in this 3GPP release</i>
Duration	M	Duration
Cause for Record Closing	M	Cause for Record Closing
Diagnostics	O _M	Diagnostics
Record Sequence Number	C	Record Sequence Number
Node ID	O _M	Node ID
Record Extensions	O _C	Record Extensions
Local Record Sequence Number	O _M	Local Record Sequence Number
APN Selection Mode	O _M	APN Selection Mode
Served MSISDN	O _M	Served MSISDN
User Location Information	O _C	<i>Not applicable in this 3GPP release</i>
Charging Characteristics	M	Charging Characteristics
Charging Characteristics Selection Mode	O _M	Charging Characteristics Selection Mode
IMS Signalling Context	O _C	<i>Not applicable in this 3GPP release</i>
External Charging Identifier	O _C	<i>Not applicable in this 3GPP release</i>
SGSN PLMN Identifier	O _M	WAG PLMN identifier
CAMEL Information	O _C	<i>Not applicable</i>
RAT Type	O _C	<i>Can be used to differentiate G-CDR used for 3GPP access from G-CDR for WLAN access.</i>

NOTE: The 'Serving AAA server/Proxy address' and 'WLAN session ID' fields are not covered by the G-CDR.

B.2.2 Online charging

In the configuration where the PDG is implemented by GGSN/TTG, the GGSN performs online charging as described in TS 32.251 [11].

Annex C (informative): Change history

Change history								
Date	TSG #	TSG Doc.	CR	Rev	Subject/Comment	Cat	Old	New
Mar 2005	SA_27	SP-050028	--	--	Submitted to TSG SA#27 for Information	--	1.0.0	1.6.0
Sep 2005	SA_29	SP-050436	--	--	Submitted to TSG SA#29 for Approval	--	2.0.0	6.0.0
Jun 2006	SA_32	SP-060246	0001	--	Correction to I-WLAN Charging Identities	F	6.0.0	6.1.0
Sep 2006	SA_33	SP-060521	0002	--	Correction to Served PDP Address in WLAN-AN-CDR	F	6.1.0	6.2.0
Dec 2006	SA_34	SP-060716	0003	--	Add an identifier for the service initiating offline Diameter Accounting	B	6.2.0	7.0.0
Jun 2008	SA_40	SP-080330	0004	1	WLAN online charging	F	7.0.0	8.0.0
Sep 2009	SA_45	SP-090537	0005	-	Add I-WLAN related reference and some definitions	B	8.0.0	9.0.0
Dec 2010	SA_50	SP-100763	0006	2	Add Packet Data Gateway (PDG) charging when re-using GGSN functionality – Align with SA2 TS 23.234	B	9.0.0	10.0.0
Mar 2011	SA_51	SP-110113	0007	2	Add Packet Data Gateway (PDG) online charging when re-using GGSN functionality	F	10.0.0	10.1.0

History

Document history		
V10.1.0	April 2011	Publication