

# ETSI TS 132 255 V17.9.0 (2023-04)



**5G;**  
**Telecommunication management; Charging management;**  
**5G data connectivity domain charging; Stage 2**  
**(3GPP TS 32.255 version 17.9.0 Release 17)**



---

Reference

RTS/TSGS-0532255vh90

---

Keywords

5G

**ETSI**

650 Route des Lucioles  
F-06921 Sophia Antipolis Cedex - FRANCE

Tel.: +33 4 92 94 42 00 Fax: +33 4 93 65 47 16

Siret N° 348 623 562 00017 - APE 7112B  
Association à but non lucratif enregistrée à la  
Sous-Préfecture de Grasse (06) N° w061004871

---

**Important notice**

The present document can be downloaded from:

<https://www.etsi.org/standards-search>

The present document may be made available in electronic versions and/or in print. The content of any electronic and/or print versions of the present document shall not be modified without the prior written authorization of ETSI. In case of any existing or perceived difference in contents between such versions and/or in print, the prevailing version of an ETSI deliverable is the one made publicly available in PDF format at [www.etsi.org/deliver](http://www.etsi.org/deliver).

Users of the present document should be aware that the document may be subject to revision or change of status.

Information on the current status of this and other ETSI documents is available at

<https://portal.etsi.org/TB/ETSIDeliverableStatus.aspx>

If you find errors in the present document, please send your comment to one of the following services:

<https://portal.etsi.org/People/CommitteeSupportStaff.aspx>

If you find a security vulnerability in the present document, please report it through our  
Coordinated Vulnerability Disclosure Program:

<https://www.etsi.org/standards/coordinated-vulnerability-disclosure>

---

**Notice of disclaimer & limitation of liability**

The information provided in the present deliverable is directed solely to professionals who have the appropriate degree of experience to understand and interpret its content in accordance with generally accepted engineering or other professional standard and applicable regulations.

No recommendation as to products and services or vendors is made or should be implied.

No representation or warranty is made that this deliverable is technically accurate or sufficient or conforms to any law and/or governmental rule and/or regulation and further, no representation or warranty is made of merchantability or fitness for any particular purpose or against infringement of intellectual property rights.

In no event shall ETSI be held liable for loss of profits or any other incidental or consequential damages.

Any software contained in this deliverable is provided "AS IS" with no warranties, express or implied, including but not limited to, the warranties of merchantability, fitness for a particular purpose and non-infringement of intellectual property rights and ETSI shall not be held liable in any event for any damages whatsoever (including, without limitation, damages for loss of profits, business interruption, loss of information, or any other pecuniary loss) arising out of or related to the use of or inability to use the software.

---

**Copyright Notification**

No part may be reproduced or utilized in any form or by any means, electronic or mechanical, including photocopying and microfilm except as authorized by written permission of ETSI.

The content of the PDF version shall not be modified without the written authorization of ETSI.

The copyright and the foregoing restriction extend to reproduction in all media.

© ETSI 2023.  
All rights reserved.

---

# Intellectual Property Rights

## Essential patents

IPRs essential or potentially essential to normative deliverables may have been declared to ETSI. The declarations pertaining to these essential IPRs, if any, are publicly available for **ETSI members and non-members**, and can be found in ETSI SR 000 314: "*Intellectual Property Rights (IPRs); Essential, or potentially Essential, IPRs notified to ETSI in respect of ETSI standards*", which is available from the ETSI Secretariat. Latest updates are available on the ETSI Web server (<https://ipr.etsi.org/>).

Pursuant to the ETSI Directives including the ETSI IPR Policy, no investigation regarding the essentiality of IPRs, including IPR searches, has been carried out by ETSI. No guarantee can be given as to the existence of other IPRs not referenced in ETSI SR 000 314 (or the updates on the ETSI Web server) which are, or may be, or may become, essential to the present document.

## Trademarks

The present document may include trademarks and/or tradenames which are asserted and/or registered by their owners. ETSI claims no ownership of these except for any which are indicated as being the property of ETSI, and conveys no right to use or reproduce any trademark and/or tradename. Mention of those trademarks in the present document does not constitute an endorsement by ETSI of products, services or organizations associated with those trademarks.

**DECT™**, **PLUGTESTS™**, **UMTS™** and the ETSI logo are trademarks of ETSI registered for the benefit of its Members. **3GPP™** and **LTE™** are trademarks of ETSI registered for the benefit of its Members and of the 3GPP Organizational Partners. **oneM2M™** logo is a trademark of ETSI registered for the benefit of its Members and of the oneM2M Partners. **GSM®** and the GSM logo are trademarks registered and owned by the GSM Association.

---

# Legal Notice

This Technical Specification (TS) has been produced by ETSI 3rd Generation Partnership Project (3GPP).

The present document may refer to technical specifications or reports using their 3GPP identities. These shall be interpreted as being references to the corresponding ETSI deliverables.

The cross reference between 3GPP and ETSI identities can be found under <https://webapp.etsi.org/key/queryform.asp>.

---

# Modal verbs terminology

In the present document "**shall**", "**shall not**", "**should**", "**should not**", "**may**", "**need not**", "**will**", "**will not**", "**can**" and "**cannot**" are to be interpreted as described in clause 3.2 of the [ETSI Drafting Rules](#) (Verbal forms for the expression of provisions).

"**must**" and "**must not**" are **NOT** allowed in ETSI deliverables except when used in direct citation.

# Contents

Intellectual Property Rights .....	2
Legal Notice .....	2
Modal verbs terminology.....	2
Foreword.....	8
1 Scope.....	9
2 References .....	9
3 Definitions, symbols and abbreviations .....	10
3.1 Definitions.....	10
3.2 Symbols.....	10
3.3 Abbreviations .....	11
4 Architecture considerations .....	12
4.1 High-level 5G System architecture .....	12
4.1.1 Non-roaming reference architecture .....	12
4.1.2 Roaming Home Routed reference architecture .....	12
4.1.3 Interworking with EPC architecture .....	12
4.1.4 Architecture reference for Non-3GPP Accesses .....	13
4.1.5 Architecture for deployments topologies with specific SMF Service Areas .....	14
4.1.5.1 Non-roaming architecture with an I-SMF insertion without ULCL/BP.....	14
4.1.5.2 Non-roaming architecture with an I-SMF insertion with ULCL/BP.....	14
4.1.6 Architecture reference for ATSSS support.....	15
4.1.7 Architecture reference for Wireline Access network.....	15
4.1.8 Roaming Local Breakout reference architecture.....	16
4.2 5G data connectivity domain converged charging architecture.....	17
5 5G data connectivity charging principles and scenarios .....	20
5.1 5G data connectivity charging principles .....	20
5.1.1 General.....	20
5.1.2 Requirements .....	20
5.1.3 Charging information.....	21
5.1.4 Charging Identifier.....	22
5.1.5 PCC rules and charging .....	23
5.1.5.1 PCC rules and chargeable events .....	23
5.1.5.2 Specific PCC rules scenarios.....	23
5.1.5.3 PCC rules - MA PDU session .....	23
5.1.6 Session and Service Continuity modes .....	23
5.1.7 UE Presence in Presence Reporting Area (PRA).....	24
5.1.8 CHF selection .....	24
5.1.9 Roaming.....	24
5.1.9.1 General .....	24
5.1.9.2 CHF selection.....	25
5.1.10 Data Volume Reporting for Secondary RAT usage.....	26
5.1.11 Charging method and Charging service selection.....	26
5.1.12 Emergency PDU session handling .....	27
5.1.13 Support of deployments topologies with specific SMF Service Areas .....	27
5.1.14 Ultra Reliable Low Latency Communication .....	27
5.1.14.1 General .....	27
5.1.14.2 Support redundant transmission for high reliability communication .....	27
5.1.14.3 QoS Monitoring to Assist URLLC Service.....	27
5.1.14.4 Void.....	28
5.1.15 5G LAN-type Service Communication.....	28
5.1.15.1 General .....	28
5.1.15.2 Support 5G VN group communication .....	28
5.1.16 Support of Cellular IoT.....	28
5.1.17 Application based charging.....	28

5.2	5G data connectivity converged online and offline charging scenarios .....	29
5.2.1	Basic principles.....	29
5.2.1.1	General .....	29
5.2.1.2	Applicable Triggers in the SMF.....	29
5.2.1.2.1	General .....	29
5.2.1.2.2	Flow Based Charging (FBC) triggers .....	30
5.2.1.2.3	QoS flow Based Charging (QBC) triggers .....	30
5.2.1.3	PDU session charging .....	31
5.2.1.4	Flow Based Charging (FBC).....	31
5.2.1.5	SSC Mode and Triggers .....	40
5.2.1.6	QoS flow Based Charging (QBC).....	42
5.2.1.7	Roaming QoS flow Based charging (QBC) .....	48
5.2.1.8	Termination action .....	48
5.2.1.9	Sponsored data connectivity charging.....	49
5.2.1.10	Branching point or UL CL controlled by I-SMF.....	49
5.2.1.11	CHF-Controlled Quota Management .....	49
5.2.1.12	URLLC Charging.....	50
5.2.1.13	NR REDCAP Charging.....	50
5.2.1.14	Additional actor (MVNO) Charging .....	50
5.2.1.14.1	General .....	50
5.2.2	Message flows .....	51
5.2.2.1	General .....	51
5.2.2.2	PDU session charging from SMF.....	51
5.2.2.2.1	General .....	51
5.2.2.2.2	PDU session establishment.....	51
5.2.2.2.3	PDU Session Modification .....	53
5.2.2.2.4	PDU Session Release .....	54
5.2.2.3	PDU session charging SSC Mode 1 from SMF .....	55
5.2.2.3.1	General .....	55
5.2.2.3.2	PDU session charging SSC Mode 1 .....	55
5.2.2.4	PDU session Charging SSC Mode 2 from SMF .....	56
5.2.2.4.1	General .....	56
5.2.2.4.2	PDU session Charging SSC Mode 2 .....	56
5.2.2.5	PDU session Charging SSC Mode 3 from SMF .....	58
5.2.2.5.1	General .....	58
5.2.2.5.2	PDU session Charging SSC Mode 3 .....	58
5.2.2.6	PDU session Charging SSC Mode 3 IPv6 Multi Homed from SMF .....	59
5.2.2.6.1	General .....	59
5.2.2.6.2	PDU session Charging SSC Mode 3 IPv6 Multi Homed .....	59
5.2.2.7	Addition of additional PDU Session Anchor and Branching Point or UL CL .....	61
5.2.2.8	Removal of additional PDU Session Anchor and Branching Point or UL CL.....	62
5.2.2.9	Change of additional PDU Session Anchor for IPv6 multi-homing or UL CL.....	63
5.2.2.10	Simultaneous change of Branching Point or UL CL and additional PSA for a PDU Session.....	64
5.2.2.11	PDU session charging for interworking with EPC.....	66
5.2.2.11.1	General .....	66
5.2.2.11.2	5GS to EPS handover using N26 interface .....	67
5.2.2.11.3	EPS to 5GS handover using N26 interface .....	68
5.2.2.11.4	Handover Cancel .....	69
5.2.2.11.5	EPS to 5GS mobility without N26 interface.....	70
5.2.2.11.6	5GS to EPS mobility without N26 interface.....	72
5.2.2.11.7	EPS to 5GS handover for roaming in Home routed scenario .....	73
5.2.2.11.8	Handover from EPC/ePDG to 5GS .....	74
5.2.2.11.9	Handover from 5GS to EPC/ePDG .....	75
5.2.2.12	PDU session charging for roaming in Home routed scenario .....	76
5.2.2.12.1	General .....	76
5.2.2.12.2	PDU session establishment.....	76
5.2.2.12.3	PDU session modification .....	78
5.2.2.12.4	PDU session release .....	79
5.2.2.13	PDU session charging - non-3GPP access .....	81
5.2.2.13.1	General .....	81
5.2.2.13.2	PDU session establishment.....	81
5.2.2.13.3	PDU session modification .....	82

5.2.2.13.4	PDU session release .....	83
5.2.2.14	PDU session served by I-SMF and SMF.....	84
5.2.2.14.1	General .....	84
5.2.2.14.2	PDU session establishment with I-SMF insertion .....	85
5.2.2.14.3	PDU Session modification procedure with I-SMF involved .....	87
5.2.2.14.4	PDU Session release procedure with I-SMF involved .....	89
5.2.2.14.5	PDU Session procedures with I-SMF insertion/change/removal .....	90
5.2.2.14.6	5GS to EPS handover using N26 interface with I-SMF removal .....	92
5.2.2.14.7	EPS to 5GS handover using N26 interface with I-SMF insertion .....	93
5.2.2.14.8	Addition/removal/change of PSA and UL CL or BP controlled by I-SMF .....	93
5.2.2.14.9	Roaming Home routed PDU session - inter-PLMN V-SMF change.....	95
5.2.2.14.10	Roaming Home routed PDU session - intra-PLMN V-SMF change.....	96
5.2.2.15	PDU session charging from SMF - ATSSS .....	98
5.2.2.15.1	General .....	98
5.2.2.15.2	UE requested MA PDU session establishment.....	98
5.2.2.15.3	UE requested PDU session establishment with Network Modification to MA PDU Session.....	100
5.2.2.15.4	UE Requested PDU Session Establishment with Network Modification to MA PDU Session - roaming in Home routed scenario .....	101
5.2.2.15.4.1	UE registered to the same VPLMN over 3GPP access and non-3GPP access.....	101
5.2.2.15.5	UE requested MA PDU session establishment - roaming in Home routed scenario .....	101
5.2.2.15.5.1	General.....	101
5.2.2.15.5.2	UE registered to the same VPLMN over 3GPP access and non-3GPP access.....	101
5.2.2.15.6	EPS interworking.....	103
5.2.2.15.6.1	5GS to EPS handover using N26 interface .....	103
5.2.2.15.6.2	5GS to EPS mobility without N26 interface .....	103
5.2.2.15.7	Hybrid Access with Multi-Access PDU Session connectivity over NG-RAN and W-5GAN .....	104
5.2.2.15.8	Hybrid Access with multi-access connectivity over E-UTRAN/EPC and W-5GAN.....	104
5.2.2.16	PDU session charging – wireline access .....	106
5.2.2.16.1	General .....	106
5.2.2.16.2	5G-RG Requested PDU Session Establishment via W-5GAN.....	107
5.2.2.16.3	FN-RG related PDU Session Establishment via W-5GAN .....	107
5.2.2.16.4	Handover procedure .....	108
5.2.2.16.4.1	5G RG handover of a PDU Session procedure from W-5GAN access to 3GPP access.....	108
5.2.2.16.4.2	5G RG handover of a PDU Session procedure from 3GPP to W-5GAN access .....	109
5.2.2.17	Ultra Reliable Low Latency Communication (URLLC).....	110
5.2.2.17.1	General .....	110
5.2.2.17.2	Void.....	110
5.2.2.17.3	Redundant transmission for high reliability communication.....	110
5.2.2.17.3.1	PDU Session establishment .....	110
5.2.2.17.3.2	PDU Session Modification .....	111
5.2.2.17.3.3	PDU Session Release.....	111
5.2.2.18	PDU session charging for roaming in Local breakout scenario .....	112
5.2.2.18.1	General .....	112
5.2.2.18.2	PDU session establishment.....	112
5.2.2.18.3	PDU Session Modification .....	113
5.2.2.18.4	PDU Session Release .....	114
5.2.2.19	PDU session charging for additional actor (MVNO) .....	115
5.2.2.19.1	General .....	115
5.2.2.19.2	Additional actor (MVNO) .....	115
5.2.3	CDR generation .....	115
5.2.3.1	Introduction.....	115
5.2.3.2	Triggers for CHF CDR.....	115
5.2.3.2.1	General .....	115
5.2.3.2.2	Triggers for CHF CDR charging information addition .....	115
5.2.3.2.3	Triggers for CHF CDR partial record closure .....	116
5.2.3.2.4	Triggers for CHF CDR closure .....	117
5.2.3.3	Triggers for CHF CDR for roaming QBC.....	117
5.2.3.3.1	General .....	117
5.2.3.3.2	Triggers for CHF CDR charging information addition for roaming QBC .....	117
5.2.3.3.3	Triggers for CHF CDR partial record closure for roaming QBC .....	118
5.2.3.3.4	Triggers for roaming QBC CHF CDR closure .....	118
5.2.4	Ga record transfer flows .....	118

5.2.5	Bd CDR file transfer .....	118
6.	Definition of charging information .....	119
6.1	Data description for 5G data connectivity charging .....	119
6.1.1	Message contents .....	119
6.1.1.1	General .....	119
6.1.1.2	Charging Data Request message .....	120
6.1.1.3	Charging data response message .....	121
6.1.2	Ga message contents .....	121
6.1.3	CDR description on the B <sub>d</sub> interface .....	121
6.1.3.1	General .....	121
6.1.3.2	PDU session charging CHF CDR data .....	121
6.1.3.3	Roaming QBC CHF CDR data .....	124
6.2	5G data connectivity charging specific parameters .....	124
6.2.1	Definition of 5G data connectivity charging information .....	124
6.2.1.1	General .....	124
6.2.1.2	Definition of PDU session charging information .....	125
6.2.1.3	Definition of PDU Container information .....	128
6.2.1.4	Definition of roaming QBC information .....	130
6.2.1.5	Definition of QFI Container information .....	130
6.2.2	Detailed message format for converged charging .....	131
6.2.3	Formal 5G data connectivity charging parameter description .....	137
6.2.3.1	5G data connectivity CHF CDR parameters .....	137
6.2.3.2	5G data connectivity resources attributes .....	137
<b>Annex A (normative):</b>	<b>Charging Characteristics .....</b>	<b>138</b>
A.1	General .....	138
<b>Annex B (normative):</b>	<b>Interworking.....</b>	<b>139</b>
B.1	General .....	139
B.2	Definition of charging information for interworking .....	139
B.2.1	Data description for interworking with EPC .....	139
B.2.1.1	Message contents .....	139
B.2.1.2	Ga message contents .....	139
B.2.1.3	CDR description on the B <sub>d</sub> interface .....	139
B.2.2	Interworking charging specific parameters .....	139
B.2.2.1	Definition of Interworking charging information .....	139
B.2.2.1.1	Message content .....	139
B.2.2.1.2	Roaming QBC information .....	139
B.2.2.1.3	QFI Container Information .....	140
B.2.2.2	Detailed message format for Interworking charging .....	140
B.2.2.3	Formal Interworking charging parameter description.....	141
<b>Annex C (normative):</b>	<b>Support of GERAN/UTRAN access .....</b>	<b>142</b>
C.1	General .....	142
C.2	5G data connectivity charging principles and scenarios .....	142
C.2.1	5G data connectivity charging principles .....	142
C.2.2	5G data connectivity converged online and offline charging scenarios .....	142
C.2.3	CDR generation and transfer .....	142
C.3	Data description for 5G data connectivity charging.....	143
C.3.1	Data description for support of GERAN/UTRAN access .....	143
C.3.1.1	Message contents .....	143
C.3.1.2	Ga message contents .....	143
C.3.1.3	CDR description on the B <sub>d</sub> interface.....	143
C.3.2	5G data connectivity charging specific parameters .....	143
C.3.2.1	Definition of 5G data connectivity charging information .....	143
C.3.2.2	Detailed message format for converged charging .....	145
C.3.2.3	Formal 5G data connectivity charging parameter description .....	145

<b>Annex D (informative):</b>	<b>Network slice charging based on 5G data connectivity</b> .....	<b>146</b>
D.1	General .....	146
D.2	Architecture.....	146
D.3	Network slice charging based on 5G data connectivity principles.....	146
D.3.1	General .....	146
D.4	Network slice charging based on 5G data connectivity scenarios.....	147
D.4.1	Basic principles .....	147
D.4.1.1	CHF selection .....	147
D.4.2	Message flows .....	147
D.5	Definition of charging information .....	147
<b>Annex E (informative):</b>	<b>Change history</b> .....	<b>149</b>
History .....		154



---

# Foreword

This Technical Specification has been produced by the 3rd Generation Partnership Project (3GPP).

The contents of the present document are subject to continuing work within the TSG and may change following formal TSG approval. Should the TSG modify the contents of the present document, it will be re-released by the TSG with an identifying change of release date and an increase in version number as follows:

Version x.y.z

where:

- x the first digit:
  - 1 presented to TSG for information;
  - 2 presented to TSG for approval;
  - 3 or greater indicates TSG approved document under change control.
- y the second digit is incremented for all changes of substance, i.e. technical enhancements, corrections, updates, etc.
- z the third digit is incremented when editorial only changes have been incorporated in the document.

---

# 1 Scope

The present document is part of a series of documents that specify charging functionality and charging management in 3GPP networks. The 3GPP core network charging architecture and principles are specified in TS 32.240 [1], which provides an umbrella for other charging management TSs that specify:

- the content of the CDRs per domain / subsystem / service (offline charging);
- the content of real-time charging messages per domain / subsystem / service (online charging);
- the functionality of online and offline charging for those domains / subsystems / services;
- the interfaces that are used in the charging framework to transfer the charging information (i.e. CDRs or charging events).

The complete document structure for these TSs is defined in TS 32.240 [1].

The present document specifies the converged offline and online charging description for the 5G Data Connectivity domain based on the functional stage 2 description in TS 23.501 [200], TS 23.502 [201] and TS 23.503 [202].

This charging description includes the converged offline and online charging architecture and scenarios specific to the 5G Data Connectivity domain, as well as the mapping of the common 3GPP charging architecture specified in TS 32.240 [1] onto the 5G Data Connectivity domain.

It further specifies the structure and content of the CDRs for offline charging, and the charging events for converged online and offline charging. The present document is related to other 3GPP charging TSs as follows:

- The common 3GPP charging architecture is specified in TS 32.240 [1].
- The parameters, abstract syntax and encoding rules for the CDRs are specified in TS 32.298 [51].
- A transaction based mechanism for the transfer of CDRs within the network is specified in TS 32.295 [54].
- The file based mechanism used to transfer the CDRs from the network to the operator's billing domain (e.g. the billing system or a mediation device) is specified in TS 32.297 [52].
- The services, operations and procedures of charging, using Service Based Interface are specified in TS 32.290 [57].
- The charging service of 5G system is specified in TS 32.291 [58].

All references, abbreviations, definitions, descriptions, principles and requirements, used in the present document, that are common across 3GPP TSs, are defined in TR 21.905 [100]. Those that are common across charging management in 3GPP networks/domains, services or subsystems are provided in the umbrella TS 32.240 [1] and are copied into clause 3 of the present document for ease of reading. Finally, those items that are specific to the present document are defined exclusively in the present document.

---

# 2 References

The following documents contain provisions which, through reference in this text, constitute provisions of the present document.

- References are either specific (identified by date of publication, edition number, version number, etc.) or non-specific.
- For a specific reference, subsequent revisions do not apply.
- For a non-specific reference, the latest version applies. In the case of a reference to a 3GPP document (including a GSM document), a non-specific reference implicitly refers to the latest version of that document *in the same Release as the present document*.

[1] 3GPP TS 32.240: "Telecommunication management; Charging management; Charging architecture and principles".

[2] - [50]	Void.
[51]	3GPP TS 32.298: "Telecommunication management; Charging management; Charging Data Record (CDR) parameter description".
[52]	3GPP TS 32.297: "Telecommunication management; Charging management; Charging Data Record (CDR) file format and transfer".
[53]	Void.
[54]	3GPP TS 32.295: "Telecommunication management; Charging management; Charging Data Record (CDR) transfer".
[55-56]	Void.
[57]	3GPP TS 32.290: "Telecommunication management; Charging management; 5G system; Services, operations and procedures of charging using Service Based Interface (SBI)".
[58]	3GPP TS 32.291: " Telecommunication management; Charging management; 5G system; Charging service, stage 3".
[59] - [99]	Void.
[100]	3GPP TR 21.905: "Vocabulary for 3GPP Specifications".
[101]	3GPP TS 22.115: "Service aspects; Charging and billing".
[102]	3GPP TS 22.261: "Service requirements for next generation new services and markets".
[103] - [199]	Void
[200]	3GPP TS 23.501:"System Architecture for the 5G System".
[201]	3GPP TS 23.502:"Procedures for the 5G System".
[202]	3GPP TS 23.503:"Policy and Charging Control Framework for the 5G System; Stage 2".
[203]	3GPP TS 23.316: "Wireless and wireline convergence access support for the 5G System (5GS)".
[204] - [299]	Void
[300] - [399]	Void.
[400] - [499]	Void.
[500] - [599]	Void.

---

## 3 Definitions, symbols and abbreviations

### 3.1 Definitions

For the purposes of the present document, the terms and definitions given in 3GPP TR 21.905 [100] and the following apply. A term defined in the present document takes precedence over the definition of the same term, if any, in 3GPP TR 21.905 [100].

### 3.2 Symbols

For the purposes of the present document, the following symbols apply:

Bd	Reference point for the CDR file transfer from the 5G Data connectivity CGF to the BD.
Ga	Reference point for CDR transfer between a CDF and the CGF.
Nchf	Service based interface exhibited by CHF.

N40 Reference point between SMF and the CHF.

### 3.3 Abbreviations

For the purposes of the present document, the abbreviations given in 3GPP TR 21.905 [100] and the following apply. An abbreviation defined in the present document takes precedence over the definition of the same abbreviation, if any, in 3GPP TR 21.905 [100].

5GC	5G Core Network
5GS	5G System
ABMF	Account Balance Management Function
AF	Application Function
AMF	Access and Mobility Management Function
ATSSS	Access Traffic Steering, Switching, Splitting
AUSF	Authentication Server Function
BD	Billing Domain
CCS	Converged Charging System
CDF	Charging Data Function
CGF	Charging Gateway Function
CHF	Charging Function
CIoT	Cellular Internet of Things
CP	Control Plane
CTF	Charging Trigger Function
DNN	Data Network Name
FBC	Flow Based Charging
IoT	Internet of Things
GPSI	Generic Public Subscription Identifier
GUAMI	Globally Unique AMF Identifier
MA	Multi-Access
MPTCP	Multi-Path TCP Protocol
MTC	Machine-Type Communications
N3IWF	Non-3GPP InterWorking Function
NE	Network Element
NEF	Network Exposure Function
NF	Network Function
NRF	Network Repository Function
NSSF	Network Slice Selection Function
OCF	Online Charging Function
OCS	Online Charging System
PCC	Policy and Charging Control
PCF	Policy Control Function
PEI	Permanent Equipment Identifier
QBC	QoS flow Based Charging
QFI	QoS Flow Identifier
SCP	Service Communication Proxy
SDF	Service Data Flow
SMF	Session Management Function
SSC	Session and Service Continuity
SUPI	Subscription Permanent Identifier
TNAN	Trusted Non-3GPP Access Network
TNAP	Trusted Non-3GPP Access Point
UDM	Unified Data Management
UDR	Unified Data Repository
UPF	User Plane Function

## 4 Architecture considerations

### 4.1 High-level 5G System architecture

#### 4.1.1 Non-roaming reference architecture

Figure 4.1.1.1 shows the 5G System high level architecture as defined in TS 23.501 [200] for 5G data connectivity, in the service-based representation for Control Plane (CP) Network Functions.

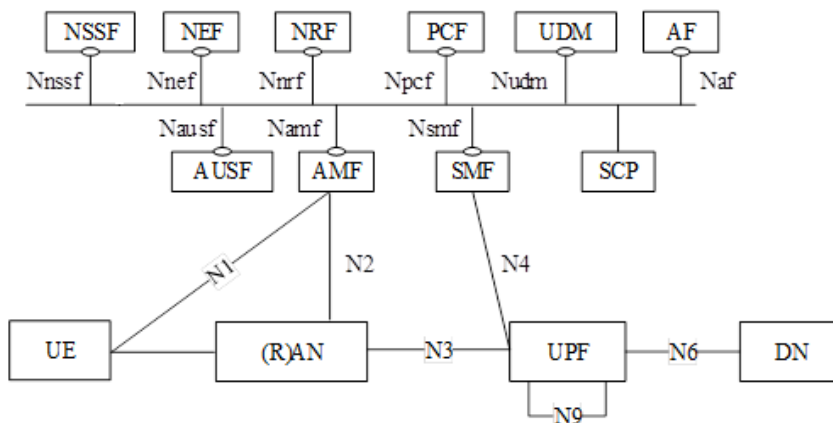

Figure 4.1.1.1: 5G System architecture

#### 4.1.2 Roaming Home Routed reference architecture

Figure 4.1.2.1 shows the 5G System high level Roaming Home Routed architecture as defined in TS 23.501 [200] for 5G data connectivity, in the service-based representation for Control Plane (CP) Network Functions.

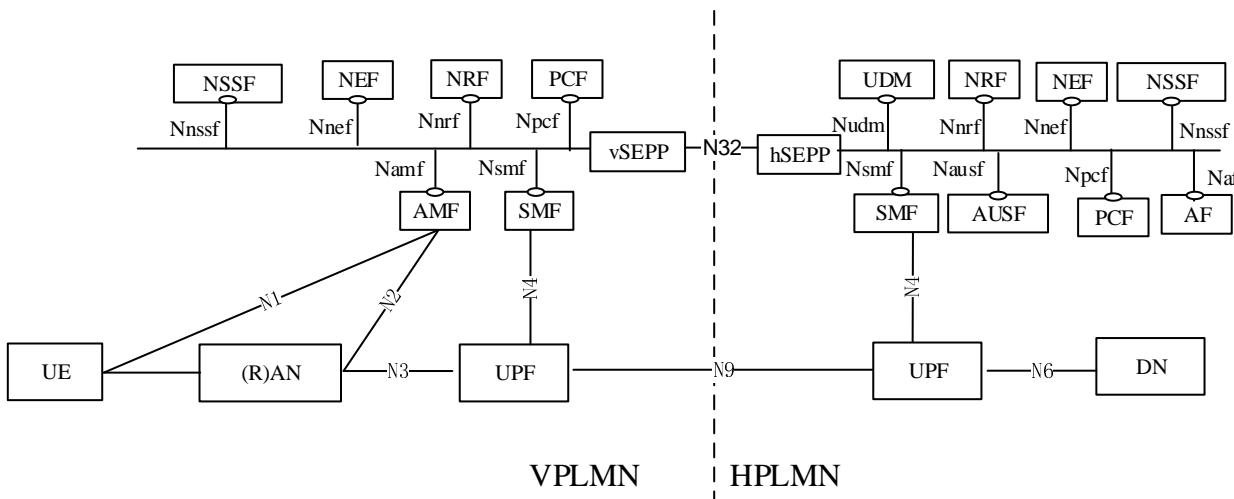
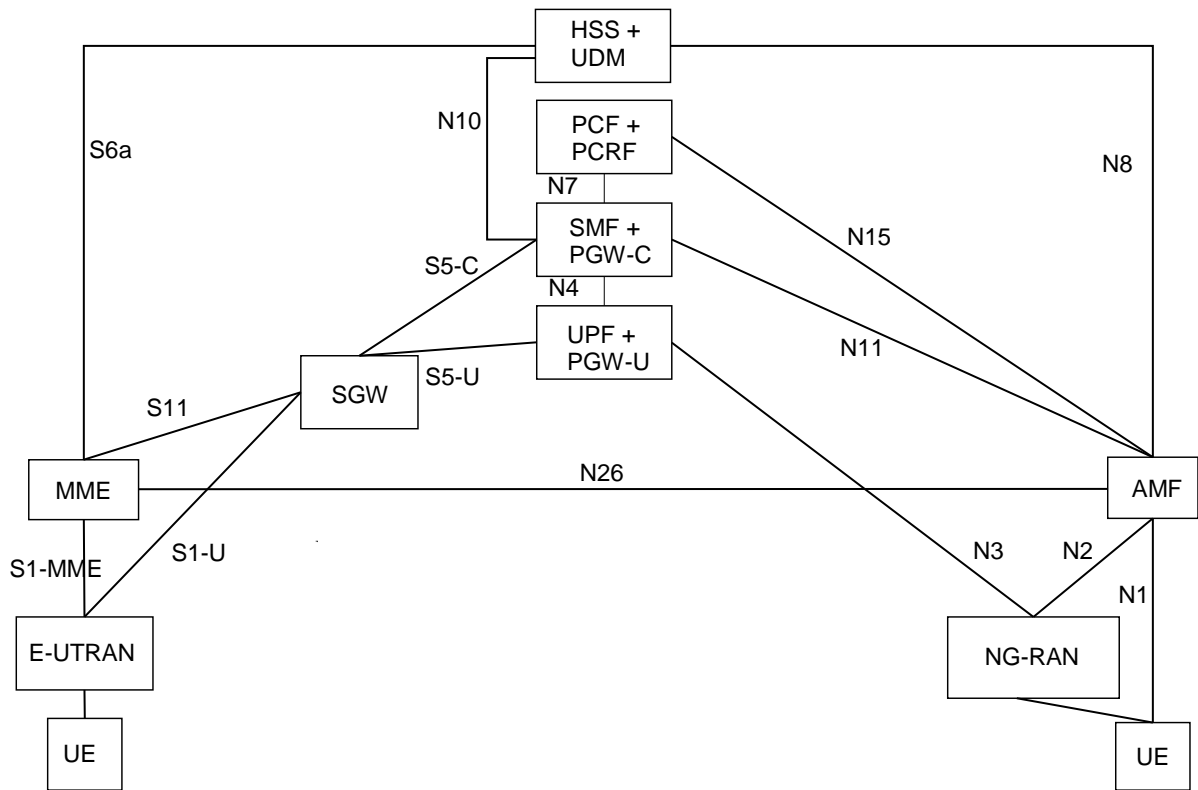

Figure 4.1.2.1: Roaming 5G System architecture - home routed scenario in service-based interface representation

#### 4.1.3 Interworking with EPC architecture

Figure 4.1.3.1 shows the non-roaming architecture for interworking between 5GS and EPC/E-UTRAN as defined in TS 23.501 [200] for 5G data connectivity.

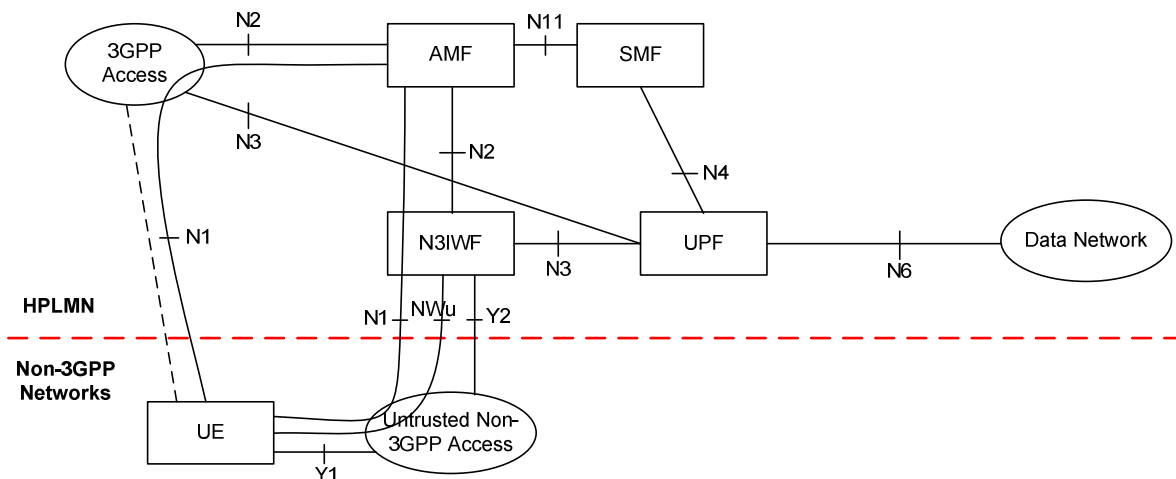

**Figure 4.1.3.1: Non-roaming architecture for interworking between 5GS and EPC/E-UTRAN**

NOTE: N26 interface is an inter-CN interface between the MME and 5GS AMF in order to enable interworking between EPC and the NG core. Support of N26 interface in the network is optional for interworking.

#### 4.1.4 Architecture reference for Non-3GPP Accesses

Figure 4.1.4.1 shows the non-roaming architecture for Non-3GPP Accesses as defined in TS 23.501 [200] for 5G data connectivity.



**Figure 4.1.4.1: Non-roaming architecture for Untrusted Non-3GPP Accesses**

This reference architecture supports service based interfaces for AMF, SMF and other NFs not represented in the figure.

Figure 4.1.4.2 shows the non-roaming architecture for 5G Core Network with trusted non-3GPP access as defined in TS 23.501 [200] for 5G data connectivity.

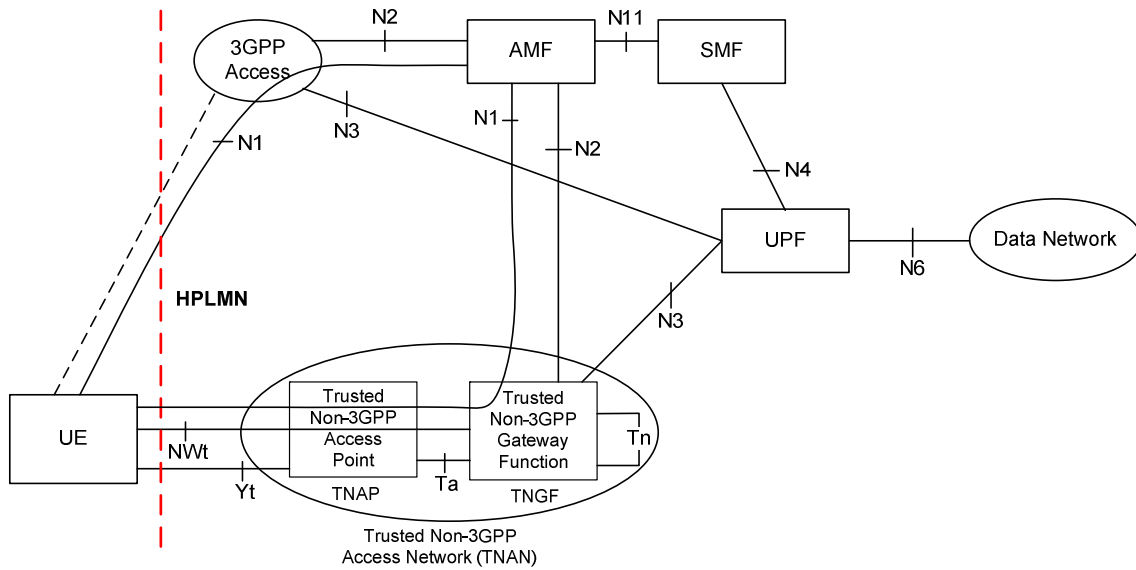

**Figure 4.1.4.2: Non-roaming architecture for 5G Core Network with trusted non-3GPP access**

The UE is connected to the 5G Core Network over non-3GPP access. This reference architecture supports service based interfaces for AMF, SMF and other NFs not represented in the figure.

### 4.1.5 Architecture for deployments topologies with specific SMF Service Areas

#### 4.1.5.1 Non-roaming architecture with an I-SMF insertion without ULCL/BP

Figure 4.1.5.1 shows the 5G System high level non-roaming architecture, as defined in TS 23.501 [200], with an I-SMF insertion to the PDU Session without UL-CL/BP, using reference point representation.

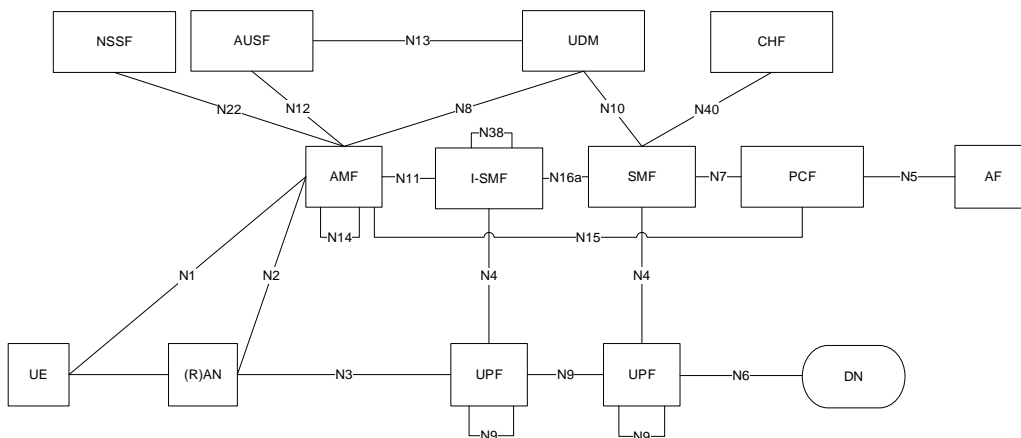

**Figure 4.1.5.1: Non-roaming architecture with I-SMF insertion to the PDU Session in reference point representation, with no UL-CL/BP**

#### 4.1.5.2 Non-roaming architecture with an I-SMF insertion with ULCL/BP

Figure 4.1.5.2 shows the 5G System high level non-roaming architecture, as defined in TS 23.501 [200], for an I-SMF insertion to the PDU Session with UL-CL/BP, using reference point representation.





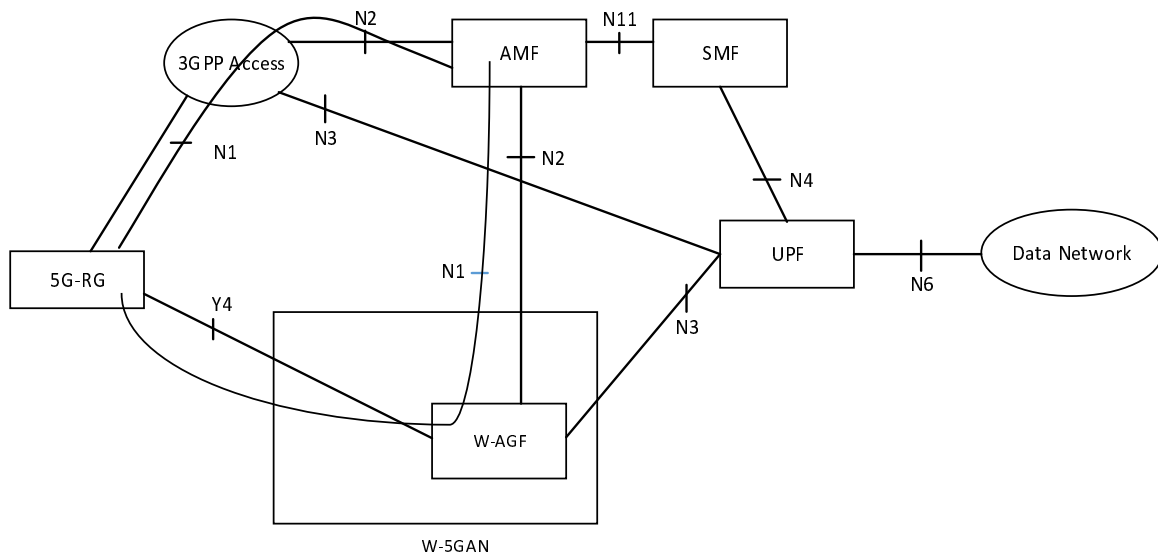

**Figure 4.1.7.1: Non- roaming architecture for 5G Core Network for 5G-RG with Wireline 5G Access network and NG RAN**

The 5G-RG can be connected to 5GC via W-5GAN, NG RAN or via both accesses. The reference architecture in Figure 4.1.7.1 shows service based interfaces for AMF, SMF and other NFs are not represented in this figure.

Non- roaming architecture for 5G Core Network for FN-RG with Wireline 5G Access network is specified in TS 23.501 [200].

### 4.1.8 Roaming Local Breakout reference architecture

Figure 4.1.8.1 shows the 5G System high level Roaming Local Breakout architecture as defined in TS 23.501 [200] for 5G data connectivity, in the service-based representation for Control Plane (CP) Network Functions.

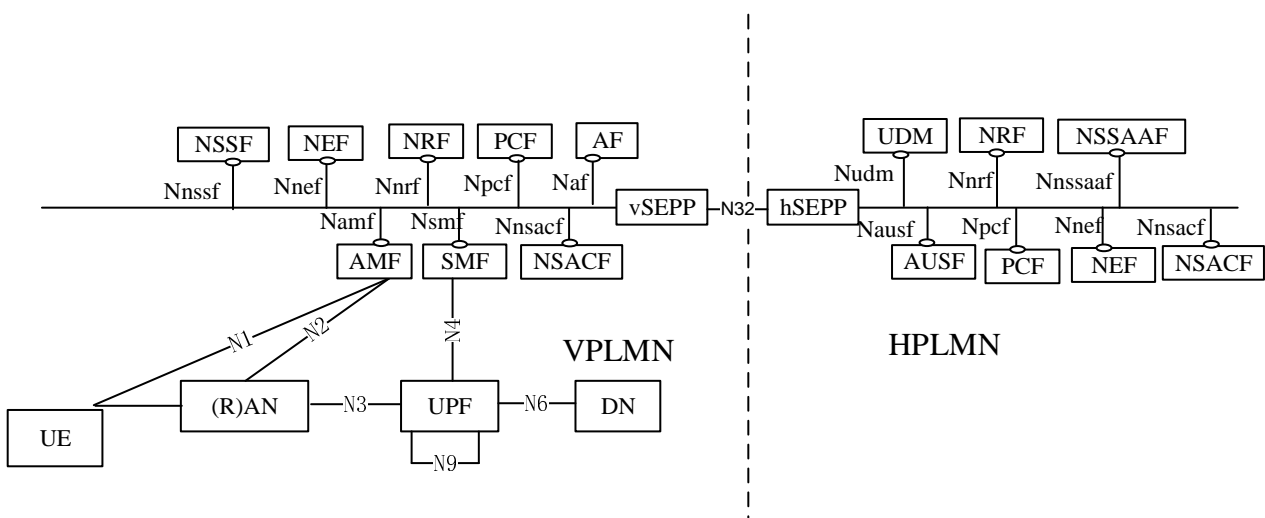

**Figure 4.1.8.1: Roaming 5G System architecture- local breakout scenario in service-based interface representation**

## 4.2 5G data connectivity domain converged charging architecture

The SMF embedding the CTF, generates charging events towards the CHF for data connectivity converged charging or offline only charging.

As described in TS 32.240 [1], the CTF generates charging events towards to the CHF for converged online and offline charging processing. The CDRs generation is performed by the CHF acting as a CDF, which transfers them to the CGF. Finally, the CGF creates CDR files and forwards them to the BD.

If the CGF is external, the CHF acting as a CDF, forwards the CDRs to the CGF across the Ga interface.

If the CGF is integrated, there is only one internal interface between the CHF and the CGF. In this case, the relationship between CHF and CGF is 1:1. An integrated CGF may support the Ga interface from other CDFs.

When an external CGF is used, this CGF may also be used by other, i.e. non-5GCS, network elements, according to network design and operator decision. It should be noted that the CGF may also be an integrated component of the BD – in this case, the Bd interface does not exist and is replaced by a proprietary solution internal to the BD.

Figure 4.2.1 depicts the architectural options for converged charging in service-based representation for CHF.

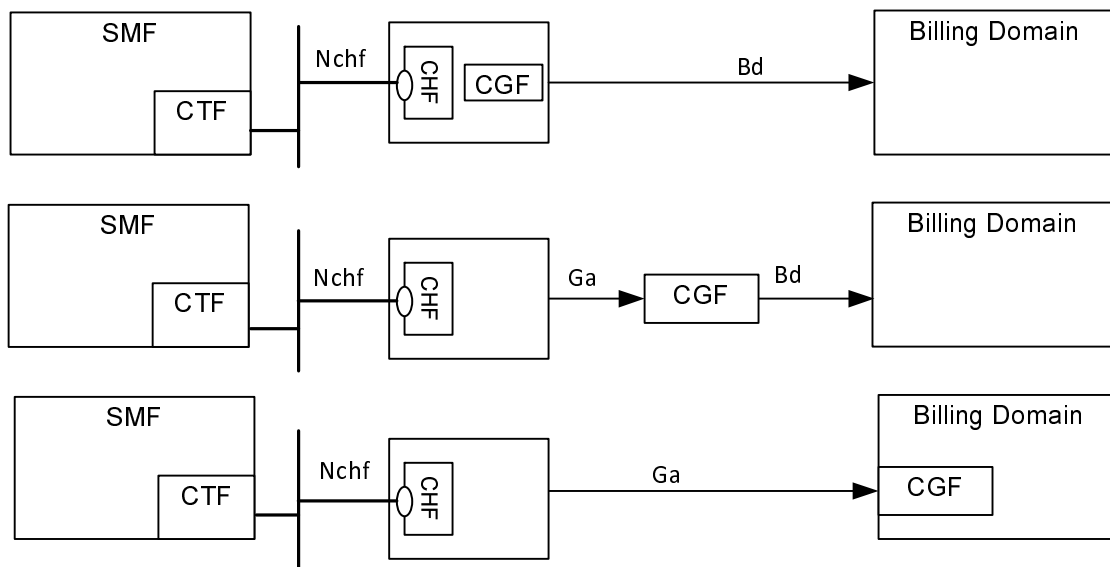
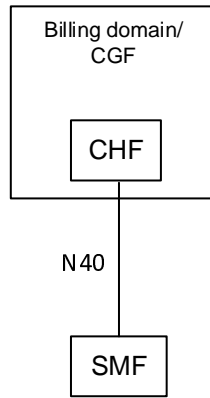

**Figure 4.2.1: 5G data connectivity converged charging architecture**

Architectural options of figure 4.2.1 apply to any 5G data connectivity converged charging architectures in this clause.

Ga is described in clause 5.2.4 and Bd in clause 5.2.5. of the present document and Nchf is described in TS 32.290 [57].

Figure 4.2.2 depicts the 5G data connectivity converged charging architecture in reference point representation for non-roaming:



**Figure 4.2.2: 5G data connectivity converged charging architecture non-roaming reference point representation**

Figure 4.2.3 depicts the 5G data connectivity converged charging architecture service-based representation for roaming Home Routed:

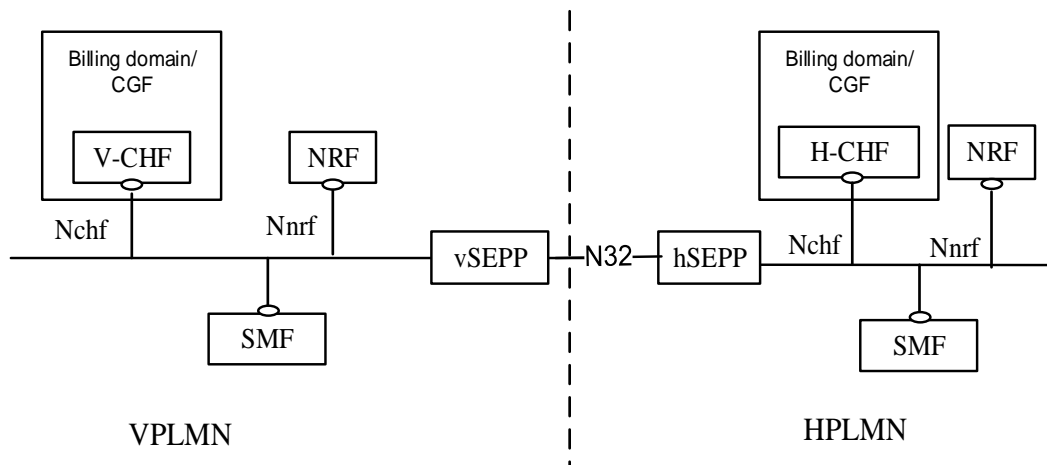

**Figure 4.2.3: 5G data connectivity converged charging architecture roaming Home Routed service based representation**

Figure 4.2.4 depicts the 5G data connectivity converged charging architecture for roaming Home Routed in reference point representation:

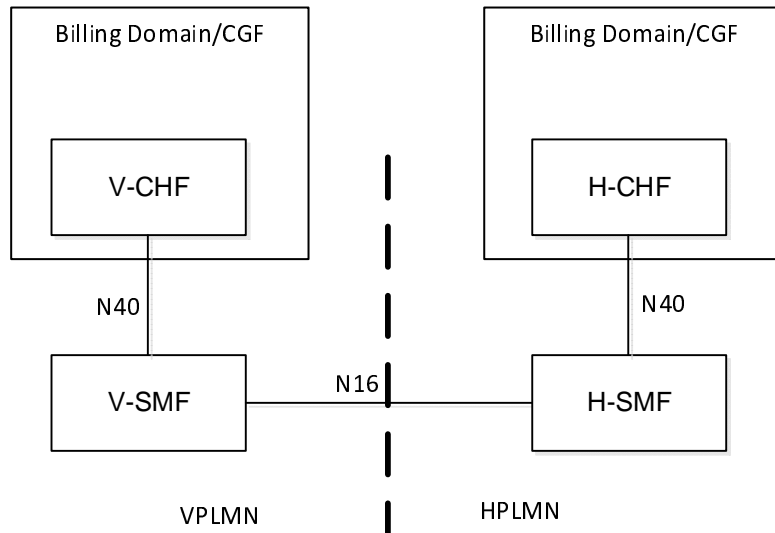

**Figure 4.2.4: 5G data connectivity converged charging architecture in roaming Home routed reference point representation**

The N40 reference point is defined for the interactions between H-SMF and H-CHF and between V-SMF and V-CHF in the reference point representation.

Figure 4.2.X depicts the 5G data connectivity converged charging architecture service-based representation for roaming Local Breakout:

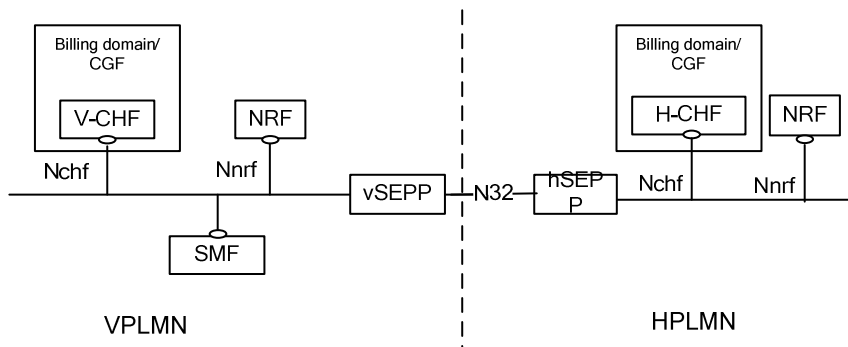

**Figure 4.2.5: 5G data connectivity converged charging architecture roaming Local Breakout scenario service based representation**

Figure 4.2.5 depicts the 5G data connectivity converged charging architecture for roaming Local breakout in reference point representation:

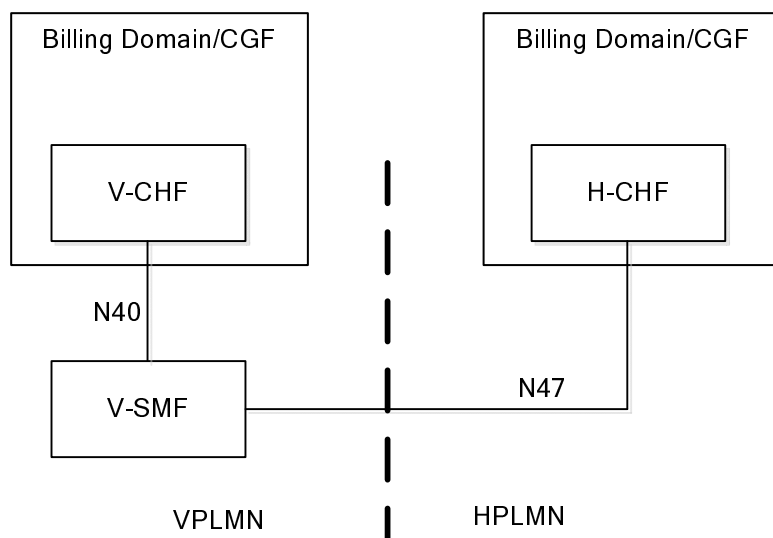

**Figure 4.2.5: 5G data connectivity converged charging architecture in Local breakout scenario reference point representation**

The N40 reference point is defined for the interactions between V-SMF and V-CHF, the N47 reference point is defined for the interactions between V-SMF and H-CHF and in the reference point representation.

For scenarios with MVNO (owning a CHF referred to as A-CHF) non-roaming, the N40 reference point is defined for the interactions between SMF and CHF owned by MNO, the N47 reference point is used for the interactions between SMF owned by the MNO and A-CHF owned by the MVNO in the reference point representation.

N47 used by A-CHF owned by an additional actor (i.e. MVNO) to perform retail charging for its own subscribers is operator specific.

## 5 5G data connectivity charging principles and scenarios

### 5.1 5G data connectivity charging principles

#### 5.1.1 General

The charging functions specified for the 5G data connectivity charging:

- PDU session in SMF, refer to TS 23.501 [200];
- service data flows, within PDU session, refer to TS 23.503 [202].
- QoS flows within PDU session refer to TS 23.501 [200] and TS 23.503 [202].

#### 5.1.2 Requirements

The following are high-level charging requirements specific to the packet domain, derived from the requirements in TS 22.115 [101], TS 22.261 [102], TS 23.501 [200], TS 23.502 [201] and TS 23.503 [202].

- The SMF shall support converged online and offline charging.
- The SMF may support offline only charging.
- The SMF shall support PDU session charging using service based interface.

- The SMF shall support network slice instance charging.
- The SMF shall collect charging information per PDU session for UEs served under 3GPP access and non-3GPP access (untrusted non-3GPP access, trusted non-3GPP access and wireline).
- Every PDU session shall be assigned a unique identity number for billing purposes per PLMN. (i.e. the Charging Id).
- Data volumes on both the uplink and downlink directions shall be counted separately. The data volumes shall reflect the data as delivered to and forwarded from the user.
- The charging mechanisms shall provide the date and time information when the PDU session starts.
- The SMF shall be capable of handling the Charging Characteristics. Charging Characteristics can be specific to a subscription or subscribed DNN.
- The SMF may be capable of identifying data volumes, elapsed time or events for individual service data flows (flow based charging). One PCC rule identifies one service data flow.
- SMF shall allow reporting of the service or the detected application usage per rating group or per combination of the rating group and service id. This reporting level can be activated per PCC rule.
- The quota management shall be per rating group per PDU session.
- If there are multiple UPFs for one PDU session, the quota management may be one for all UPFs or separate per UPF and the usage and charging information reporting per UPF.
- The SMF shall support charging for PDU Session types of IP, Ethernet and Unstructured.
- In Home Routed scenario, the SMF shall collect charging information per PDU session and, based on Home Operator policy and agreement between Home and Visit Operators, shall be able to collect charging information per QoS Flow for in-bound and out-bound roamers in Home Routed scenario.
- In Local breakout scenarios, the SMF in VPLMN shall collect charging information per QoS flow and, based on Visited Operator policy and agreement between Home and Visit Operator, may be able to collect charging information per service data flow for roamers in the LBO scenario.
- For interworking between 5GS and EPC, the dedicated PGW-C + SMF shall collect charging information using the same mechanisms as the SMF.
- The SMF shall support PDU session charging when the PDU session is served by both I-SMF and SMF.
- The SMF shall support charging for MA PDU Connectivity Service over 3GPP access and non-3GPP access.
- The SMF in VPLMN and in HPLMN shall support charging for MA PDU Connectivity Service in roaming Home Routed scenario with UE registered to the same VPLMN for 3GPP access and non-3GPP access.
- The SMF in HPLMN shall support charging for MA PDU Connectivity Service in roaming Home Routed scenario with UE registered in different PLMNs.
- The SMF shall support the charging of redundant transmission for high reliability communication.
- The SMF shall support the charging of 5G LAN VN group communication.
- The SMF shall support the charging of 5GS CIoT.

### 5.1.3 Charging information

Charging information in the 5GC domain network is collected for each UE by the SMFs. PDU session charging allows the SMF to collect and categorize per UE per UPF per PDU session, charging information related to data volumes.

The SMF shall collect the following charging information for converged online and offline charging:

- usage of the access and core network resources: the charging information shall describe the amount of data delivered to and forwarded from the UE;

- usage duration: duration of PDU session is counted as the time interval from PDU session establishment to PDU session release;
- user: the charging information shall provide the actual UE addresses used by the user for the PDU session;
- data network: the charging information shall describe the data network addresses with a level of accuracy as determined by the DNN;
- usage of the external data networks: the charging information shall describe the amount of data sent and received to and from the external data network. External networks can be identified by the DNN;
- start time: identifying the time when the PDU session was started;
- user location: HPLMN, VPLMN, inside/outside presence reporting area, plus optional higher-accuracy location information.

The service data flows categorization is achieved by rating group or combination of the rating group and service id: i.e. based on the level of reporting defined per PCC rule, counting per rating group or combination of the rating group and service id. According to TS 23.503 [202], flow based charging shall support different charging models per PCC rule. These charging models may be based on volume, time and/or on number of events matching a specific service data flow template in PCC rule.

For service data flows defined for FBC, the SMF shall collect the following charging information:

- the information described above for PDU session;
- the amount of data transmitted in uplink and downlink directions categorized by rating group or combination of the rating group and service id when volume based charging applies;
- the duration of service data flows is counted and categorized by rating group or combination of the rating group and service id when time based charging applies;
- the number of events and corresponding time stamps categorized by rating group or combination of the rating group and service id when event based charging applies.

Within the PDU session the SMF shall collect the charging information for service data flows per UPF, categorized by rating group or combination of the rating group and service id.

Within the PDU session for local traffic offload scenarios with I-SMF insertion, the SMF shall collect the charging information for service data flows per I-SMF and categorized by rating group or combination of the rating group and service id.

**Editor's note: To have I-UPF as well as PSA2 UPF for the I-SMF controlled UPF is FFS.**

The user can be identified by a Generic Public Subscription Identifier (GPSI) and/or a 5G Subscription Permanent Identifier (SUPI). For wireline access, SUPI may be used to identify subscriber via wireline network as specified in clause 5.9.2 of TS 23.501 [200].

## 5.1.4 Charging Identifier

Charging identifier is created to allow correlation of charging information.

For the SMF the charging identifier is assigned per PDU session including the case of I-SMF insertion. At each PDU session establishment, i.e. , assignment of a new PDU session id, a new PDU session specific Charging Identifier is generated at the first SMF that processes the PDU session initiating request. The Charging Identifier shall be unique within the SMF (that means that the charging identifier is unique within the SMF set if SMF set is used) which assigned it and is then used in all subsequent messages for that PDU session. The Charging Identifier shall be used throughout the PDU session's lifetime once assigned. In case of inter-system changes or handovers of PDU session, the Charging Identifier is preserved while the PDU session Identifier is preserved.

For EPS handover 5GS in Home routed scenario, the Charging Identifier for the EPS PDN connection will be generated by PGW-C+SMF in HPLMN and transferred to the SMF in VPLMN, if the V-SMF has already generated the Charging Identifier, the value shall be replaced by a home provided Charging Identifier generated by H-SMF.

For 5GS interworking with EPS, an EPS bearer Charging Identifier is assigned by the PGW-C+SMF to each dedicated EPS bearer. The EPS default bearer Charging Identifier is the Charging Identifier assigned to the default bearer of PDU connection.

For mobility from HPLMN with I-SMF to VPLMN in Home routed scenario, the charging identifier for the PDU session will be generated by SMF in HPLMN and transferred to the SMF in VPLMN, if the V-SMF has already generated a Charging Identifier, the value shall be replaced by a home provided Charging Identifier generated by H-SMF.

## 5.1.5 PCC rules and charging

### 5.1.5.1 PCC rules and chargeable events

PCC rules can be activated, deactivated and modified at any time during the PDU session lifetime. The following attribute can be modified by the PCF in a dynamic PCC rule active in the SMF: Charging key, Service identifier, Sponsor Identifier, Application Service Provider Identifier, Measurement method and reporting level. The QoS Flow binding mechanism employed by the SMF upon operations on PCC rules, may result in QoS Flows establishment, modification, or release. This is specified in TS 23.503 [202].

Activities on PCC rules are not chargeable events. However, change of charging rule in PCC rules will lead to chargeable events "start of service data flow" and when this is the last service data flow for the original PCC rule, "termination of service data flow".

The charging key (i.e. Rating group) is a piece of information used to request online charging quotas as defined in TS 23.503 [202].

### 5.1.5.2 Specific PCC rules scenarios

The capability of SMF to support Application Based Charging is achieved with appropriate PCC rules activation in the SMF. Such PCC Rule shall be defined with service data flow template including an Application Identifier for the application which needs to be detected, enforced and charged. Application detection mechanism in SMF is defined in TS 23.503 [202].

### 5.1.5.3 PCC rules - MA PDU session

As specified with PCC Rule definition in clause 6.3.1 TS 23.503 [202], during MA PDU session handling by the SMF, PCC Rules can be activated with a MA PDU session control information attribute including an optional rating group for Non-3GPP access, in addition to the rating group included in the PCC rule description.

When the MA PDU session control information in a PCC Rule includes a separate rating group for Non-3GPP access, it shall be used by the SMF for the SDF traffic carried via non-3GPP access. The PCC Rule rating group shall be used for the SDF traffic carried via 3GPP access, and all other charging related attributes in the PCC rule shall be used for both accesses.

When the MA PDU session control information in a PCC Rule does not include any rating group for Non-3GPP access, the PCC Rule rating group shall be used by the SMF for the SDF traffic carried via both accesses (i.e. 3GPP access and non-3GPP access).

## 5.1.6 Session and Service Continuity modes

For any scenario of SSC modes specified in TS 23.501 [200], one Charging Identifier shall correspond to a single PDU session ID.

As a result, from such SSC mode, a new Charging Identifier is generated by the SMF for the new PDU session Id, and the charging session associated to the old PDU session Id is released.

This behaviour applies to the following scenario:

- PDU session anchor UPF relocation, in SSC mode 2;
- PDU session anchor UPF relocation in SSC mode 3 with multiple PDU Sessions.



## 5.1.7 UE Presence in Presence Reporting Area (PRA)

During charging session lifetime, the CHF may provide the Presence Reporting Area identifier to be activated for Core Network pre-configured Presence Reporting Area(s) and additionally all of PRA Identifier(s) and list(s) of its elements for UE-dedicated Presence Reporting Area(s) and provision the "Change of UE presence in Presence Reporting Area(s)" trigger to the SMF to request the reporting of Change of UE presence in Presence Reporting Area. After such trigger is enabled, SMF shall close the current count, open a new count with the initial status of UE presence in the PRA(s). In case of quota management is required, a Charging Data Response [Update] including the initial status is sent. UE presence status in the PRA(s) describes whether the UE is entering or leaving Presence Reporting Area (s) and if the corresponding Presence Reporting Area(s) is set to inactive by the serving node.

The CHF may modify the list of PRA Identifier(s) by providing the new Presence Reporting Area(s) or by removing existing Presence Reporting Area(s) or modify the list(s) of Presence Reporting Area elements by providing the updated Presence Reporting Area.

The CHF may remove the trigger of change of UE presence in Presence Reporting Area as defined in subclause 5.2.1.2, if previously activated.

## 5.1.8 CHF selection

The CHF selection by the SMF is done at the PDU session establishment, this selection shall be based on the following and with this priority order (highest to lowest):

- CHF address(es) with possible associated CHF instance ID(s) and/or CHF set ID(s) provided by the PCF for the PDU session.
- UDM provided charging characteristics.
- NRF based discovery.
- SMF locally provisioned charging characteristics.

This means that if there are PCF provided CHF address(es) with possible associated CHF instance ID(s) and/or CHF set ID(s) these shall be used, otherwise if the UDM provides charging characteristics these shall be used. If neither of these results in CHF address(es) the NRF can be used to discover CHF instance(s) possibly within a CHF set, and as a last resource the SMF locally provisioned charging characteristics shall be used.

When NRF is used for the CHF selection, and the PDU session charging method indicates "offline only" for the PDU session, CHF instance(s) supporting CHF "offline only" service instances may be selected.

## 5.1.9 Roaming

### 5.1.9.1 General

In home routed scenario, based on roaming agreements between the V-PLMN and the H-PLMN, for each UE roaming in VPLMN:

- The SMF in VPLMN (V-SMF) shall be able to collect charging information per QoS Flow within a PDU session when UE is determined as an in-bound roamer, for CDR generation in VPLMN.
- The SMF in HPLMN (H-SMF) shall be able to collect charging information per QoS Flow within a PDU session when UE is determined as an out-bound roamer, for CDR generation in HPLMN.

In home routed scenario, this charging information collection mechanism is achieved under Roaming QoS flow Based Charging (QBC) performed by each PLMN, based on a set of charging parameters exchanged between the V-SMF and the H-SMF on a per PDU session basis.

In home routed scenario, the main parameters exchanged at PDU session establishment are:

- The Charging Identifier assigned by the V-SMF and transferred to the H-SMF in the HPLMN.
- Optionally, the "Roaming Charging Profile" negotiated between the VPLMN and the HPLMN.

In home routed scenario, the parameters exchanged during the PDU session handover from EPS to 5GS:

- The home provided Charging Identifier which includes the Charging Identifier assigned by the H-SMF to the original PDU session over EPS and transferred by the H-SMF to the V-SMF. This home provided Charging Identifier shall be used by the V-SMF to replace the existing Charging Identifier previously generated by V-SMF.
- Optionally, the "Roaming Charging Profile" negotiated between the VPLMN and the HPLMN on 5GS side.

In roaming home routed PDU session, upon V-SMF change:

- intra-PLMN V-SMF change: Charging Identifier, "Roaming Charging Profile" and optionally CHF address are transferred from the old V-SMF to the new V-SMF.

NOTE: how the new V-SMF selects the V-CHF is operator specific.

- inter-PLMN V-SMF change: Charging Identifier is transferred from the old V-SMF to the new V-SMF.
- The "Roaming Charging Profile" is optionally exchanged between the new V-SMF and the H-SMF as for a PDU session establishment.

In local breakout scenario, based on roaming agreements between the V-PLMN and the H-PLMN, for each UE roaming in VPLMN:

- The SMF in VPLMN (V-SMF) shall be able to collect charging information within a PDU session when UE is determined as a roamer:
  - per QoS flow for CDR generation by V-CHF in VPLMN and CDR generation by H-CHF in HPLMN;
  - per service data flow for converged charging, based on PCC rules from V-PCF which uses locally configured policies according to the roaming agreement with the HPLMN operator, when applicable:
    - with or without quota management to H-CHF in HPLMN;
    - without quota management to V-CHF in VPLMN.
- The SMF in VPLMN (V-SMF) shall be able to determine applicable combinations based on operator policy.

In local breakout scenario, the main parameters exchanged at PDU session establishment are:

- The Charging Identifier assigned by the V-SMF and reported to the V-CHF and H-CHF.
- Optionally, for QBC, the "Roaming Charging Profile" is used for the set of triggers, associated category, and trigger thresholds and negotiated between the VPLMN and the HPLMN

In roaming Home routed PDU session, when a UE moves from HPLMN with I-SMF insertion to a VPLMN:

- The home provided Charging Identifier assigned by the H-SMF to the original PDU session and transferred by the H-SMF to the V-SMF. This home provided Charging Identifier shall be used by the V-SMF to replace the existing Charging Identifier previously generated by V-SMF.
- Optionally, the "Roaming Charging Profile" negotiated between the VPLMN and the HPLMN.

### 5.1.9.2 CHF selection

In home routed scenario, at PDU session establishment, the CHF selection mechanism specified in clause 5.1.8 applies to:

- The V-SMF for CHF selection in VPLMN, with the following differences:
  - CHF address(es) selection mechanisms based on PCF and UDM are not applicable.
  - When charging characteristics is used it will be based on local configuration .
- When NRF is used, the V-CHF can be selected based on UE identified as in-bound roamer and the PLMN Id of the H-PLMN.

- The H-SMF for CHF selection in HPLMN can be done as for non-roaming case.

In roaming home routed, PDU session upon V-SMF change:

- Intra-PLMN V-SMF change: CHF address supplied by the old V-SMF shall be used.
- Inter-PLMN V-SMF change: CHF selection mechanism as per V-SMF CHF selection in VPLMN at PDU session establishment.

In local breakout scenario, at PDU session establishment, the CHF selection mechanism specified in clause 5.1.8 applies to:

- The V-SMF for CHF selection in VPLMN, is the same as in the home routed scenario.
- The V-SMF for CHF selection in HPLMN, with the following differences.
  - CHF address(es) selection mechanisms based on PCF, UDM, and local configuration are not applicable.
  - NRF based discovery, the H-CHF can be selected based on the H-PLMN of the UE.

### 5.1.10 Data Volume Reporting for Secondary RAT usage

Volume reporting for Secondary RAT usage is an optional capability in the SMF that provides usage reporting functionality when a Secondary RAT is used by NG-RAN. Use of Secondary RAT refers to options supported by NG-RAN with dual radio accesses, per NG-RAN definition in TS 23.501 [200]. This is valid for both HPLMN and VPLMN.

The following principles are used:

- The reporting of Secondary RAT Data Volume is controlled by the NG-RAN.
- The uplink and downlink data volumes for the Secondary RAT are reported (from NG-RAN to 5G Core) on a per QoS Flow basis and per time interval (controlled by NG-RAN). The report contains Secondary RAT (e.g. E-UTRA) resources used for transport of user data and indicated separately for uplink and downlink per QoS Flow and per time interval. The time interval used for the measurements reported (from NG-RAN) may be partitioned to indicate usage that occurred before respectively after an absolute time (that occurs while measurement for secondary RAT usage report is ongoing).
- The reporting (performed by NG-RAN) in association with UE-related control signaling and via standalone reporting is internally triggered by NG-RAN.

NOTE: Volumes for the secondary RAT are reported to the CHF in addition to, and uncorrelated from volumes of reported usage, which are undifferentiated between primary and secondary RAT. Considering both volumes would imply the same traffic to be counted twice.

### 5.1.11 Charging method and Charging service selection

A PDU session charging method indicating "offline only", can be assigned to a PDU session, to indicate a charging method applicable at PDU session level.

When there is no PDU session charging method indicating "offline only" associated to a PDU session, for each PCC Rule:

- if indicated for this PCC Rule, the required charging method applies;
- otherwise (i.e. no required charging method is indicated for this PCC Rule), the default charging method applies.

In this case, the converged charging service will be invoked by the SMF at the PDU session establishment.

When a PDU session charging method indicates "offline only" for a PDU session, offline charging method applies to all the PCC Rules activated during the PDU session. In this case, at the PDU session establishment, the SMF can select between the converged charging service or the offline only charging service based on Operator policy.

This PDU session charging method can be received from PCF by the SMF or configured in the SMF charging characteristics.

## 5.1.12 Emergency PDU session handling

Volume reporting for Emergency PDU Sessions is a capability in the SMF that provides usage reporting functionality when a session is setup to provide emergency services.

The following principles are used:

- The reporting of Emergency PDU sessions is controlled by the SMF.
- The uplink and downlink data volumes for Emergency PDU Session are reported.
- It includes either or both of an unauthenticated SUPI and a PEI (especially applicable in the case where there is a UE without a UICC).

## 5.1.13 Support of deployments topologies with specific SMF Service Areas

Depending on scenario, a PDU Session in non-roaming case is either served by a single SMF or served by an SMF and an I-SMF, specified in the clause 5.34 of TS 23.501 [200]. When a PDU Session is served by both an SMF and an I-SMF, the SMF is the NF Consumer that has the interfaces towards CHF for I-SMF for the case of an I-SMF insertion, relocation or removal.

For the following case with the I-SMF involved, the SMF shall collect the charging information and report to CHF:

- PDU session establishment, modification and release;
- PDU Session message flows for N2 based handover procedure, with I-SMF insertion/change/removal;
- PDU Session message flows for Xn based handover procedure, with I-SMF insertion/change/removal;
- PDU Session message flows for Service Request, with I-SMF insertion/change/removal
- branching point or UL CL controlled by I-SMF.

## 5.1.14 Ultra Reliable Low Latency Communication

### 5.1.14.1 General

The enhancement of the 5GS to support Ultra Reliable Low Latency Communication (URLLC) is specified in the clause 5.33 of TS 23.501 [200]. For the redundant transmission for high reliability communication, the SMF shall collect the charging information for redundant transmission and report to CHF for the following cases.

- Dual Connectivity based end to end Redundant User Plane Paths;
- Redundant transmission on N3/N9 interfaces;
- Redundant transmission at transport layer.

### 5.1.14.2 Support redundant transmission for high reliability communication

The SMF reports the redundant transmission type to the CHF to indicate which redundant transmission type is used for the PDU session or service data flow.

For dual connectivity based end to end Redundant User Plane Paths, the charging information is collected independently per each redundant PDU session. The quota is granted for each redundant PDU session independently. The SMF reports the usage per redundant PDU session.

### 5.1.14.3 QoS Monitoring to Assist URLLC Service

For the QoS Monitoring to Assist URLLC Service, the SMF may report the packet delay measurement per QoS Flow per UE to CHF.

#### 5.1.14.4 Void

### 5.1.15 5G LAN-type Service Communication

#### 5.1.15.1 General

The SMF may support PDU Sessions for a 5G VN group which offers a virtual data network capable of supporting 5G LAN-type service over the 5G system, which specified in the TS 23.501[200].

The SMF embedding the CTF generates 5G VN group communication charging information towards the CHF based on the user plane architecture with the additional following options described in the clause 4.4.6 of TS 23.501[200] to support 5G LAN-type service.

- Figure 4.4.6.1-1 depicts the non-roaming user plane architecture to support 5G LAN-type service using local switch.
- Figure 4.4.6.1-2 depicts the non-roaming user plane architecture to support 5G LAN-type service using N19 tunnel.
- Figure 4.1.1 depicts the non-roaming user plane architecture to support 5G LAN-type service using N6 tunnel.

#### 5.1.15.2 Support 5G VN group communication

In order to support the 5G VN group communication, the following principles are used:

- It includes the internal group identifier of 5G VN group, which is used to indicate the 5G VN group and associate charging information for 5G VN group communication.
- The uplink and downlink data volumes of 5G VN group communication traffic usage are reported separately.
- The 5G VN group communication using N19 tunnel is measured based on the PDU session charging.
- SMF may report the traffic forwarding way information corresponding to the 5G VN group communication.

### 5.1.16 Support of Cellular IoT

The 5GS support for Cellular IoT (CIoT) is specified in TS 23.501 [200], this includes EPC interworking and home-routed roaming. In legacy networks Cellular IoT may be referred to as Machine Type Communications (MTC).

During the PDU session establishment (initial charging request) the SMF may provide the following charging information related to 5GS CIoT:

- The indication of Control Plane 5GS CIoT optimization.
- Small data rate control indication.
- The RAT types (NB-IoT or LTE-M).
- The control plane only indication.

### 5.1.17 Application based charging

If reporting on applications (e.g., edge application) is required it's recommended to assign each application with its own service id.

## 5.2 5G data connectivity converged online and offline charging scenarios

### 5.2.1 Basic principles

#### 5.2.1.1 General

Converged charging may be performed by the SMF interacting with CHF using Nchf specified in TS 32.290 [57] and TS 32.291 [58]. In order to provide the data required for the management activities outlined in TS 32.240 [1] (Credit-Control, accounting, billing, statistics etc.), the SMF shall be able to perform converged charging for each of the following:

- Charging data related to PDU session;
- Charging data related to service data flows within the PDU session.

Converged charging includes quota management and usage reporting.

The SMF shall be able to report charging events to CDF for CDR generation.

The SMF shall be able to perform convergent charging by interacting with CHF, for charging data related to PDU sessions. The Charging Data Request and Charging Data Response are exchanged between the SMF and the CHF, based on SCUR scenarios specified in TS 32.290 [57]. The Charging Data Request is issued by the SMF towards the CHF when certain conditions (chargeable events) are met.

The quota management is always per rating group, reporting level can be either per rating group or per combination of the rating group and service id, which is defined per PCC rule.

Converged charging uses centralized or decentralized unit determination and centralized rating scenarios for session based convergent charging specified in TS 32.290 [57].

The charging information collected per PDU session includes the network slice instance the PDU session belongs to.

The contents and purpose of each charging event that triggers interaction with CHF, as well as the chargeable events that trigger them, are described in the following sub-clauses.

The SMF initiates a charging session with Charging Data Request/Response [Initial], updates the charging session with Charging Data Request/Response [Update], and terminates the charging session with Charging Data Request/Response [Termination].

A detailed formal description of the converged charging parameters defined in the present document is to be found in TS 32.291 [58].

A detailed formal description of the CDR parameters defined in the present document is to be found in TS 32.298 [51].

In order to avoid a charging session remaining inactive for a long period of time, upon expiry of the Unit Count Inactivity Timer, the charging session may be terminated by the SMF sending Charging Data Request [Termination], indicating the PDU session shall continue and the CHF can expect a later Charging Data Request [Initial] request for the same PDU session with the original Charging Identifier and new session identifier. The SMF may send its locally configured value of the Unit Count Inactivity Timer to the CHF. The CHF may respond with a new Unit Count Inactivity Timer for use in the SMF. Whether the CHF may respond with a value of the Unit Count Inactivity Timer, independent of if the CHF has received one previously from the SMF, is vendor specific

#### 5.2.1.2 Applicable Triggers in the SMF

##### 5.2.1.2.1 General

When a charging event is issued towards the CHF, it includes details such as Subscriber identifier (e.g. SUPI), Charging-id, etc. and also containers identifying the volume count (separated for uplink and downlink traffic), with charging condition change information.

Each trigger condition (i.e. chargeable event) defined for the 5G data connectivity converged charging functionality with the associated behaviours when met is specified in this document and the basic trigger mechanism is specified in the TS 32.290[57].

Two categories of chargeable events are identified:

- immediate report: chargeable events for which, when occurring, the current counts are closed and sent together with the charging data generated by the SMF towards the CHF in a Charging Data Request. New counts are started by the SMF.
- deferred report: chargeable events for which, when occurring, the current counts are closed and stored together with the charging data generated by the SMF. The stored counts will be sent to the CHF in next a Charging Data Request. New counts are started by the SMF.

When more than one trigger condition to be met at same time (i.e. time stamp of triggers is the same) for the same count in the SMF, the SMF reports the used unit container with these triggers.

When a PDU session starts, and the converged charging is activated, the SMF invokes a Charging Data Request [Initial] towards the CHF to get authorization to start based on the default triggers. The SMF is optionally provided in a Charging Data Response [Initial] to override the default triggers, with a set of chargeable event triggers to be enabled, and the associated category (i.e. immediate or deferred report).

The triggers remain active until they are updated or disabled by subsequent Charging Data Response [Update] from the CHF or the PDU session is terminated.

A set of chargeable events are based on trigger thresholds and default ones can be configured in Charging Characteristics which are described in Annex A.

The SMF is optionally provided in the Charging Data Response [Initial], with trigger thresholds which override the default ones configured in the Charging Characteristics selected by the SMF for the PDU session. They remain active until they are updated by subsequent Charging Data Response [Update] from the CHF or the PDU session is terminated.

When a trigger is enabled, the SMF needs to ensure that monitoring in UPF and subscription from RAN are setup so that SMF can report the charging information to the CHF if the chargeable event occurs.

#### 5.2.1.2.2 Flow Based Charging (FBC) triggers

The set of chargeable events and associated category, which shall be supported by the SMF as the default, is specified in the sub-clause 5.2.1.4 for Flow Based Charging.

Two level of triggers can be supplied by the CHF:

- Triggers associated to the PDU session.
- Triggers associated to a rating group within the PDU session.

The set of triggers along with their category (i.e. immediate or deferred report) and level (i.e. per PDU session or per rating group), which can be supplied by the CHF to the SMF for 5G data connectivity converged charging or offline only charging are detailed in the sub-clause 5.2.1.4 for Flow Based Charging.

#### 5.2.1.2.3 QoS flow Based Charging (QBC) triggers

The set of chargeable events and associated category, which shall be supported by the SMF as the default for QoS flow Based Charging, when applicable, is specified in the sub-clause 5.2.1.6.

Two level of triggers can be supplied by the CHF:

- Triggers associated to the PDU session.
- Triggers associated to a QoS Flow within the PDU session.

The set of triggers along with their category (i.e. immediate or deferred report) and level (i.e. per PDU session or per QoS Flow), which can be supplied by the CHF to the SMF for 5G data connectivity converged charging are detailed in clause 5.2.1.6 for QBC.

In home routed scenario, when QBC is used in the context of roaming, the set of triggers, their associated category, and trigger thresholds, compose the "Roaming Charging Profile", which governs the SMF charging data generation, synchronously between the V-SMF and the H-SMF when shared.

In local breakout scenario, the default "Roaming charging profile" for the V-SMF is based on the "Charging characteristics", and may be set, changed, applied, and transferred in the following order:

1. Default set by V-SMF and transferred to V-CHF
2. Changed by V-CHF and transferred to V-SMF
3. Transferred from V-SMF to H-CHF
4. Changed by H-CHF and transferred to V-SMF
5. Applied in V-SMF and transferred to V-CHF

In local breakout scenario, support for "Roaming changing profile" exchange is done by transferring it i.e., an NF may only change the "Roaming charging profile" if it has received it. The "Roaming charging profile" resulting from the exchange between the VPLMN and HPLMN shall remain valid until it is replaced.

In local breakout scenario, the "Roaming charging profile" overrides any triggers set or updated by the CHF for Roaming QBC.

### 5.2.1.3 PDU session charging

Converged charging allows the SMF to collect charging information related to data volumes sent to and received by the UE/MS per user per PDU session. The user can be identified by SUPI.

If PDU session specific converged charging is supported, this is achieved by FBC charging, with specific rating group/service identifier, see clause 5.2.1.4.

### 5.2.1.4 Flow Based Charging (FBC)

For FBC charging, the SMF categorizes the service data flows within PDU session data traffic by rating group and / or combination of the rating group and service id. The level of the reporting and charging method is defined per PCC rule. Details of this functionality are specified in TS 23.503 [202] and TS 32.240 [1].

The SMF can include the QoS Information per rating group or per combination of rating group/service id. If the QoS Information cannot be unambiguously determined per rating group or per combination of rating group/service id, it should be omitted.

NOTE: The SMF can only include one QoS Information occurrence per combination of rating group/service id. This implies if an operator wishes to be able to separate usage according to 5QI and ARP for the same charging method, they will need to ensure that service data flows having different 5QI and ARP do not have the same:

- rating group in cases where rating reporting is used;
- rating group/service id where rating group/service id reporting is used.

When a service data flow is governed by a PCC Rule indicated with "Online" charging method, quota management is required for the service data flow. It may also indicate if authorization for the service data flow is needed or not before service delivery, i.e. blocking or non-blocking mode.

When a service data flow is governed by a PCC Rule indicated with "Offline" charging method, quota management is not required for this service data flow. Usage reporting is required for this service data flow without affecting the delivery.

According to TS 23.503 [202], FBC shall support different charging models per PCC rule. These charging models may be based on volume and/or time and on number of events matching a specific service data flow template in PCC rule. When a chargeable event occurs for which quota needs to be requested by the SMF to the CHF, the type of requested quota may depend on measurement method configured for the PCC rule.



In general, the charging of a service data flow shall be linked to the PDU session under which the service data flow has been activated.

The amount of data counted shall be the user plane payload at the UPF separated between UL and DL.

For PDU session specific charging, time metering shall start when PDU session is activated.

Table 5.2.1.4.1 summarizes the set of default trigger conditions and their category which shall be supported by the SMF. For "immediate report" category, the table also provides the corresponding Charging Data Request [Initial, Update, Termination] message sent from SMF towards the CHF.

**Table 5.2.1.4.1: Default Trigger conditions in SMF**

Trigger Conditions	Trigger level	Converged Charging default category	Offline only charging default category	CHF allowed to change category	CHF allowed to enable and disable	Message when "immediate reporting" category
Start of PDU Session.	PDU session	Immediate	Immediate	Not Applicable	Not Applicable	Charging Data Request [Initial]
Start of the Service data flow and no charging session exists.	RG	Immediate	Immediate	No	No	
<b>Change of Charging conditions</b>						
QoS change	PDU session/ RG	Deferred	Deferred	Yes	Yes	Charging Data Request [Update]
GFBR guaranteed status change	RG	Deferred	Deferred	Yes	Yes	
User Location change	PDU session/ RG	Deferred	Deferred	Yes	Yes	
Serving Node change	PDU session/ RG	Deferred	Deferred	Yes	Yes	
Change of UE presence in Presence Reporting Area(s)	PDU session/ RG	Deferred	Deferred	Yes	Yes	
Change of 3GPP PS Data off Status	PDU session/ RG	Deferred	Deferred	Yes	Yes	
Tariff time change	PDU session/ RG	Deferred	Deferred	No	No	
UE time zone change	PDU session/ RG	Immediate	Deferred	Yes	Yes	
PLMN change	PDU session/ RG	Immediate	Deferred	Yes	Yes	
RAT type change	PDU session/ RG	Immediate	Deferred	Yes	Yes	
Session-AMBR change	PDU session	Immediate	Deferred	Yes	Yes	
Addition of UPF	PDU Session/RG	Immediate	Deferred	Yes	Yes	
Removal of UPF	PDU session/RG	Immediate	Deferred	Yes	Yes	
Insertion of I-SMF	PDU Session	Deferred	Deferred	Yes	Yes	
Change of I-SMF	PDU Session	Deferred	Deferred	Yes	Yes	
Removal of I-SMF	PDU Session	Deferred	Deferred	Yes	Yes	
Handover cancel	PDU session	Immediate	Deferred	Yes	Yes	
Handover start	PDU session	Immediate	Deferred	Yes	Yes	
Handover complete	PDU session	Immediate	Deferred	Yes	Yes	
Addition of access	PDU session/ RG	Immediate	Deferred	Yes	Yes	

Removal of access	PDU session/ RG	Immediate	Deferred	Yes	Yes
Redundant transmission change	RG	Immediate	Deferred	Yes	Yes
<b>Limit per PDU session</b>					
Expiry of data time limit per PDU session	PDU session	Immediate	Immediate	No	Yes
Expiry of data volume limit per PDU session	PDU session	Immediate	Immediate	No	Yes
Expiry of data event limit per PDU session	PDU session	Immediate	Immediate	No	Yes
Expiry of limit of number of charging condition changes	PDU session	Immediate	Immediate	No	Yes
<b>Limit per Rating group</b>					
Expiry of data time limit per rating group	RG	Deferred	Deferred	Yes	Yes
Expiry of data volume limit per rating group	RG	Deferred	Deferred	Yes	Yes
Expiry of data event limit per rating group	RG	Deferred	Deferred	Yes	Yes
<b>Quota management</b>					
Time threshold reached	RG	Immediate	Not applicable	No	Yes
Volume threshold reached	RG	Immediate	Not applicable	No	Yes
Unit threshold reached	RG	Immediate	Not applicable	No	Yes
Time quota exhausted	RG	Immediate	Not applicable	No	Yes
Volume quota exhausted	RG	Immediate	Not applicable	No	Yes
Unit quota exhausted	RG	Immediate	Not applicable	No	Yes
Expiry of quota validity time	RG	Immediate	Not applicable	No	Yes
Expiry of quota holding time	RG	Immediate	Not applicable	No	Yes
Re-authorization request by CHF	RG	Immediate	Not applicable	No	No
Start of service data flow, in case no valid quota for this rating group	RG	Immediate	Not applicable	No	No
Start of SDF additional access, in case no valid quota for this access rating group	RG	Immediate	Not applicable	No	No
<b>Others</b>					

Termination of service data flow - last service data flow under a given Rating Group.	RG	Immediate	Immediate	No	No	Charging Data Request [Termination]
Management intervention	PDU session	Immediate	Immediate	No	No	
Expiry of Unit Count Inactivity Timer	PDU session	Immediate	Not applicable	No	No	
End of PDU session	PDU session	Immediate	Immediate	No	No	
CHF response with session termination	PDU session	Immediate	Not applicable	No	No	
Abort request is received from the CHF	PDU session	Immediate	Immediate	No	No	
NOTE 1: If GFBR guaranteed status change is enabled, SMF needs to ensure the request for the notification from the access network (i.e. 3GPP RAN) when the GFBR can no longer (or can again) be guaranteed for a QoS Flow during the lifetime of the QoS Flow.						

The default "Limit" trigger conditions are trigger thresholds configured in the Charging Characteristics applied to the PDU session. It shall be possible for the CHF to override these default triggers when providing Charging Data Response [Initial], either to disable the triggers, or to enable triggers new thresholds value.

When the traffic is counted in more than one UPF, the CHF overrides these default triggers of volume limit for the all UPFs.

For converged charging, the following details of chargeable events and corresponding actions in the SMF are defined in Table 5.2.1.4.2:

**Table 5.2.1.4.2: Chargeable events and their related actions in SMF**

Chargeable event	Conditions	SMF action
Start of PDU session		Charging Data Request [Initial] with a possible request quota for later use.
Start of service data flow	If quota management is required, and valid quota for this rating group does not exist	Charging Data Request [Update] to request quota with a possible amount of quota.
	If service identifier level reporting is required by the PCC rule	Start new counts with time stamps for the combination of the rating group and service id
	If rating group level reporting is required by the PCC rule	Start new counts with time stamps for the rating group
	If sponsored connectivity level reporting is required by the PCC rule	Start new counts with time stamps for the combination of the rating group, sponsor identity and application service provider identity
	If charging resource, i.e. charging session, for the PDU session does not exist	Charging Data Request [Initial] with a possible request quota
Start of SDF additional access	If ATSSS is supported with access differentiated rating groups, quota management is required, and valid quota for this access rating group does not exist.	Charging Data Request [Update] to request quota with a possible amount of quota.
	If ATSSS is supported with access differentiated rating groups, service identifier level reporting is required by the PCC rule	Start new counts with time stamps for the combination of the access rating group and service id
	If ATSSS is supported with access differentiated rating groups, rating group level reporting is required by the PCC rule	Start new counts with time stamps for the access rating group
	If ATSSS is supported with access differentiated rating groups, sponsored connectivity level reporting is required by the PCC rule	Start new counts with time stamps for the combination of the access rating group, sponsor identity and application service provider identity
Termination of service data flow	If service identifier level reporting is required by the PCC rule and this is the last service data flow for this combination of the rating group and service id	Close the counts with time stamps
	If rating group level reporting is required by the PCC rule and this is the last service data flow utilizing that specific rating group	Close the counts with time stamps
	If sponsored connectivity level reporting is required by the PCC rule and this was the last active service data flow for this combination of rating group, sponsor identity and application service provider identity	Close the counts with time stamps
Expiry of the Unit Count Inactivity Timer for the PDU session	If the corresponding trigger is enabled	Charging Data Request [Termination], indicating that charging session is terminated, and the PDU session is still active May include the configured Unit Count Inactivity Timer value
End of PDU session in the SMF		Charging Data Request [Termination] Close the counts with time stamps
Quota specific chargeable events (e.g. threshold reached, QHT expires, quota exhaustion, validity time reached, forced re-authorization, expiry of quota holding time)	If the corresponding trigger is enabled	Charging Data Request [Update] with a possible request quota Close the counts and start new counts with time stamps
	If the corresponding trigger is enabled	Close the counts and start new counts with time stamps for all active service data flows

Chargeable event	Conditions	SMF action
Change of charging condition in the SMF (e.g. QoS change, Session-AMBR change, user location change, Radio access type change, PLMN change, Serving Node change, UE Time Zone change, change of UE presence in Presence Reporting Area(s), change of 3GPP PS Data Off status, handover cancel, GFBR guaranteed status change)	If the corresponding trigger is enabled and the category is set to "immediate reporting"	Charging Data Request [Update] with a possible request quota.
Handover start	If the corresponding trigger is enabled	Close the counts with time stamps and start new counts with time stamps for active service data flows.
	If the corresponding trigger is enabled and the category is set to "immediate reporting"	Charging Data Request [Update] with a possible request quota.
Handover cancel	If the corresponding trigger is enabled	Close the counts with time stamps and start new counts with time stamps for active service data flows.
	If the corresponding trigger is enabled and the category is set to "immediate reporting"	Charging Data Request [Update] with a possible request quota.
Handover complete	If the corresponding trigger is enabled	Close the counts with time stamps and start new counts with time stamps for active service data flows.
	If the corresponding trigger is enabled and the category is set to "immediate reporting"	Charging Data Request [Update]
Addition of UPF	If the corresponding trigger is enabled	Start new counts with time stamps for the added UPF.
	If the corresponding trigger is enabled and the category is set to "immediate reporting" with the quota management is being performed and quota is granted per each UPF	Charging Data Request [Update] to request quota with a possible amount of quota.
Tariff time change		Close the counts and start new counts with time stamps
CHF response with session termination (e.g. Not Applicable), abort request		Charging Data Request [Termination] Close the counts with time stamps
Removal of a UPF	If the corresponding trigger is enabled	Close the counts with time stamps for the removed UPF
	If the corresponding trigger is enabled and the category is set to "immediate reporting" with quota management is being performed and quota is granted per each UPF	Charging Data Request [Update].
Insertion of I-SMF	If the corresponding trigger is enabled	Close the counts with time stamps for all active service data flows in SMF, open new accounts for all active service data flows with I-SMF information.
	If the corresponding trigger is enabled and the category is set to "immediate reporting" with quota management is being performed and quota is granted per each UPF	Charging Data Request [Update] to request quota with a possible amount of quota.
Removal of I-SMF	If the corresponding trigger is enabled	Close the counts with time stamps for the removed I-SMF
	If the corresponding trigger is enabled and the category is set to "immediate reporting" with quota management being performed and quota is granted per each UPF	Charging Data Request [Update].
Change of I-SMF	If the corresponding trigger is enabled	Close the counts with time stamps for the removed I-SMF, open active traffic flows' counts for the new I-SMF



Chargeable event	Conditions	SMF action
	If the corresponding trigger is enabled and the category is set to "immediate reporting" with quota management being performed and quota is granted per each UPF	Charging Data Request [Update].
Addition of access	If the corresponding trigger is enabled	Close the counts with time stamps for all active service data flows usage report in SMF, open new counts for all active service data flows.
	If the corresponding trigger is enabled and the category is set to "immediate reporting"	Charging Data Request [Update] with a possible request quota.
Removal of access	If the corresponding trigger is enabled	Close the counts with time stamps for all active service data flows usage report in SMF, open new counts for all active service data flows.
	If the corresponding trigger is enabled and the category is set to "immediate reporting"	Charging Data Request [Update].
Redundant transmission change	If the corresponding trigger is enabled and the category is set to "immediate reporting"	Charging Data Request [Update]. Close the counts and start new counts with time stamps.
Expiry of time limit per rating group	If the corresponding trigger is enabled	Close the counts with time stamps
	If the category is set to "immediate reporting"	Charging Data Request [Update]
	If any matching service data flow is still active	Start new counts with time stamps
Expiry of data volume limit per rating group	If the corresponding trigger is enabled	Close the counts with time stamps
	If the category is set to "immediate reporting"	Charging Data Request [Update]
	If any matching service data flow is still active	Open a new service data container
Expiry of data event limit per rating group	If the corresponding trigger is enabled	Close the counts with time stamps
	If the category is set to "immediate reporting"	Charging Data Request [Update]
	If any matching service data flow is still active	Open a new service data container
Expiry of data event limit per PDU session	If the corresponding trigger is enabled	Charging Data Request [Update] Close the counts with time stamps
	If the PDU session is still active	Start new counts with time stamps
Expiry of time limit per PDU session	If the corresponding trigger is enabled	Charging Data Request [Update] Close the counts with time stamps
	If the PDU session is still active	Start new counts with time stamps
Expiry of data volume limit per PDU session		Charging Data Request [Update] Close the counts with time stamps
	If the PDU session is still active	Start new counts with time stamps
Expiry of a limit of number of charging condition changes per PDU session		Charging Data Request [Update] Close the counts with time stamps
	If the PDU session is still active	Start new counts with time stamps
Management intervention		Charging Data Request [Update] Close the counts with time stamps
	If the PDU session is still active	Start new counts with time stamps

When event based charging applies, the first occurrence of an event matching a service data flow template in PCC rule shall be considered as the start of a service.

How the termination of service data flows is detected, is specified in TS 23.503 [202]. Termination of the service data flow itself does not trigger Charging Data Request [Update].

The CDR generation mechanism processed by the CHF upon receiving Charging Data Request [Initial, Update, Termination] issued by the SMF for these chargeable events, is specified in clause 5.2.3.

### 5.2.1.5 SSC Mode and Triggers

There are two cases related to quota management when the granted quota is volume for multiple UPFs and per Operator's policy, the traffic is counted in more than one UPF:

- Quota shared by UPFs means that SMF manages the shared quota consumption per RG for multiple UPFs and reports the total quota consumed to CHF;
- Quota granted for each UPF means that the CHF manages the quota granted for each UPF and SMF manages and reports the quota consumption per UPF.

For configurations involving multiple UPFs and Operator's policy is to count the traffic in a single UPF (e.g. BP), the quota is granted to the SMF for this single UPF per RG for the whole traffic.

The following scenarios describe configurations in which the traffic is counted in more than one UPF:

In case of SSC mode 3 PDU Session Anchor with IPv6 Multi-homed PDU Session,

- The addition of UPF2 and BP (Change the part of traffic from UPF1 to UPF2):
  - if quota granted for each UPF, SMF triggers the chargeable event of Start of SDF for UPF2 to request the quota;
  - if quota shared by UPFs, SMF requests UPF1 report usage of quota, caches the usage from UPF1 and re-allocates the remaining quota to UPF2 and UPF1(if needed). When the granted quota from CHF is used up, the SMF reports total usage of quota to CHF.
- The removal of UPF1 and BP:
  - In case the quota management and quota granted for each UPF, UPF1 reports final counts to SMF, SMF triggers the chargeable event of Remove the UPF to report final counts from UPF1;
  - In case the quota management and quota shared by UPFs, UPF1 report final counts to SMF, SMF caches the final count from UPF1. SMF sends counts from UPF1 and UPF2 to the CHF together in next Charging Data Request.
  - In case without the quota management or offline only charging, UPF1 report final count to SMF, SMF caches the final count from UPF1 and sends counts from UPF1 and UPF2 to the CHF together in next a Charging Data Request. In case of Addition of additional PDU Session Anchor and Branching Point or UL CL.
- The addition of UPF2 and BP (Change the part of traffic from UPF1 to UPF2):
  - if quota granted for each UPF, SMF triggers the chargeable event of Start of SDF for UPF2 to request the quota for Rating group;
  - if quota shared by UPFs, SMF indicates UPF1 report usage of quota, caches the usage from UPF1 and re-allocates the remain quota to UPF2 and UPF1(if needed). When the granted quota from CHF is used up, the SMF reports total usage of quota to CHF.

In case of Removal of additional PDU Session Anchor and Branching Point or UL CL:

- The removal of UPF1 and BP (Change traffic from UPF1 to UPF2):
  - In case the quota management and quota granted for each UPF, UPF1 report final counts to SMF, SMF triggers chargeable event of Remove the UPF to report final counts from UPF1.
  - In case the quota management and quota shared by UPFs, UPF1 report final counts to SMF, SMF caches the final count from UPF1 and re-allocates the remain quota to UPF2. SMF sends counts from UPF1 and UPF2 to the CHF together in next a Charging Data Request.
  - In case without the quota management or offline only charging, UPF1 report final count to SMF, SMF caches the final count from UPF1 and sends counts from UPF1 and UPF2 to the CHF together in next a Charging Data Request. In case of Change of additional PDU Session Anchor for IPv6 multi-homing or UL CL and Simultaneous change of Branching Point or UL CL and additional PSA for a PDU Session.
- The additional of UPF2 (Change the part of traffic from UPF1 to UPF2):
  - if quota granted for each UPF, SMF triggers the chargeable event of Start of SDF for UPF2 to request the quota for Rating group;
  - if quota shared by UPFs, SMF indicates UPF1 report usage of quota, caches the usage from UPF1 and re-allocates the remain quota to UPF2 and UPF1(if needed). When the granted quota from CHF is used up, the SMF reports total usage of quota to CHF.
- The removal of UPF1:

- In case the quota management and quota granted for each UPF, UPF1 report final counts to SMF, SMF triggers chargeable event of Remove the UPF to report final counts from UPF1.
- In case the quota management and quota shared by UPFs, UPF1 report final counts to SMF, SMF caches the final count from UPF1 and re-allocates the remain quota to UPF2. SMF sends counts from UPF1 and UPF2 to the CHF together in next Charging Data Request.
- In case without the quota management or offline only charging, UPF1 report final count to SMF, SMF caches the final count from UPF1 and sends counts from UPF1 and UPF2 to the CHF together in next a Charging Data Request.

### 5.2.1.6 QoS flow Based Charging (QBC)

QoS flow Based Charging allows the SMF to collect charging information related to data volumes per PDU session, categorized per QoS Flow. QBC doesn't support quota management.

The user can be identified by SUPI.

For a given PDU session, QBC shall be performed by the SMF within the same charging session used for Flow Based Charging. For the case where QBC is performed from SMF in VPLMN, Flow Based Charging is not applicable and there is no possibility to have quota management for the PDU Session. For the case where QBC is performed from SMF in HPLMN, FBC can be performed or not performed at the same time according to operator's policy.

The SMF categorizes the volume within PDU session by QoS Flow identified by QoS Flow Identifier (QFI).

The amount of data counted for the QoS Flow shall be the user plane payload at the UPF.

Table 5.2.1.6.1 summarizes the set of default trigger conditions and their category which shall be supported by the SMF in QBC. For "immediate report" category, the table also provides the corresponding Charging Data Request [Initial, Update, Termination] message sent from SMF towards the CHF.

**Table 5.2.1.6.1: Default Chargeable events in SMF for QBC**

Chargeable event	Trigger level	Default category	CHF allowed to change category	CHF allowed to enable and disable	Message when "immediate reporting" category
Start of PDU session	PDU session	Immediate	Not Applicable	Not Applicable	Charging Data Request [Initial]
Start of a QoS Flow	QoS Flow	Deferred	Not Applicable	Not Applicable	Charging Data Request [Update]
<b>Change of Charging conditions</b>					
QoS change	QoS Flow	Deferred	Yes	Yes	
GFBR guaranteed status change	QoS Flow	Deferred	Yes	Yes	
User Location change	PDU session	Deferred	Yes	Yes	
Serving Node change	PDU session	Deferred	Yes	Yes	
Change of 3GPP PS Data off Status	PDU session	Deferred	Yes	Yes	
Tariff time change	PDU session	Deferred	No	No	
UE time zone change	PDU session	Immediate	Yes	Yes	
PLMN change	PDU session	Immediate	Yes	Yes	
RAT type change	PDU session	Immediate	Yes	Yes	
Session-AMBR change	PDU session	Immediate	Yes	Yes	
Addition of UPF	PDU session	Immediate	Yes	Yes	
Removal of UPF	PDU session	Immediate	Yes	Yes	
Handover cancel	PDU session	Immediate	Yes	Yes	
Handover start	PDU session	Immediate	Yes	Yes	
Handover complete	PDU session	Immediate	Yes	Yes	
Redundant transmission change	QoS Flow	Immediate	Yes	Yes	
<b>Limit per PDU session</b>					
Expiry of data time limit per PDU session	PDU session	Immediate	No	Yes	
Expiry of data volume limit per PDU session	PDU session	Immediate	No	Yes	
Expiry of data event limit per PDU session	PDU session	Immediate	No	Yes	
Expiry of limit of number of charging condition changes	PDU session	Immediate	No	Yes	
<b>Limit per QoS Flow</b>					
Expiry of data time limit per QoS Flow	QoS Flow	Deferred	Yes	Yes	
Expiry of data volume limit per QoS Flow	QoS Flow	Deferred	Yes	Yes	
<b>Others</b>					
End of QoS Flow	QoS Flow	Deferred	Yes	Yes	
Management intervention	PDU session	Immediate	No	No	
End of PDU session	PDU session	Immediate	No	No	
Abort request is received from the CHF	PDU session	Immediate	No	No	Charging Data Request [Termination]

NOTE 1: If GFBR guaranteed status change is enabled, SMF needs to ensure the request for the notification from the access network (i.e. 3GPP RAN) when the GFBR can no longer (or can again) be guaranteed for a QoS Flow during the lifetime of the QoS Flow.

NOTE 2: The columns CHF allowed to change category, and CHF allowed enable and disable are only applicable for the PDU session establishment, for other cases they are not applicable.

The default "Limit" trigger conditions, are trigger thresholds configured in the Charging Characteristics applied to the PDU session for QBC. It shall be possible for the CHF to override these default triggers when providing Charging Data Response [Initial], either to disable the triggers, or to enable triggers new thresholds value.

For QBC the following details of chargeable events and corresponding actions in the SMF are defined in Table 5.2.1.6.2:

**Table 5.2.1.6.2: Chargeable events and their related actions in SMF for QBC**

Chargeable event	Conditions	SMF action
Start of PDU session		Charging Data Request [Initial].
Start of a QoS Flow	Start of the QoS Flow associated with the default QoS rule	Charging Data Request [Update].
	Start of a QoS Flow	Start new counts with time stamps.
End of a QoS Flow		Close the counts with time stamps for the QoS flows
End of PDU session		Charging Data Request [Termination] Close the counts with time stamps
Change of charging condition in the SMF (e.g. QoS change, Session-AMBR change, user location change, Radio access type change, PLMN change, Serving Node change, UE Time Zone change, change of 3GPP PS Data Off status, GFRB guaranteed status change)	If the corresponding trigger is enabled	Close the counts and start new counts with time stamps for all active QoS flows.
	If the corresponding trigger is enabled and the category is set to "immediate reporting"	Charging Data Request [Update]
Handover start	If the corresponding trigger is enabled	Close the counts with time stamps and start new counts with time stamps.
	If the corresponding trigger is enabled and the category is set to "immediate reporting"	Charging Data Request [Update].
Handover cancel	If the corresponding trigger is enabled	Close the counts with time stamps and start new counts with time stamps for active QoS flows.
	If the corresponding trigger is enabled and the category is set to "immediate reporting"	Charging Data Request [Update].
Handover complete	If the corresponding trigger is enabled	Close the counts and start new counts with time stamps for active QoS flows.
	If the corresponding trigger is enabled and the category is set to "immediate reporting"	Charging Data Request [Update]
Redundant transmission change	If the corresponding trigger is enabled and the category is set to "immediate reporting"	Charging Data Request [Update]. Close the counts and start new counts with time stamps.
Addition of UPF	If the corresponding trigger is enabled	Start new counts with time stamps for the added UPF.
	If the corresponding trigger is enabled and the category is set to "immediate reporting"	Charging Data Request [Update].
Removal of UPF	If the corresponding trigger is enabled	Close the counts with time stamps for the removed UPF
	If the corresponding trigger is enabled and the category is set to "immediate reporting"	Charging Data Request [Update].
Expiry of time limit per QoS Flow	If the corresponding trigger is enabled	Close the counts with time stamps.
	If the category is set to "immediate reporting"	Charging Data Request [Update]
	If the QoS Flow is still active	Start new counts with time stamps
Expiry of data volume limit per QoS Flow	If the corresponding trigger is enabled	Close the counts with time stamps
	If the category is set to "immediate reporting"	Charging Data Request [Update]
	If the QoS Flow is still active	Start new counts with time stamps
Expiry of time limit per PDU session	If the corresponding trigger is enabled	Close the counts with time stamps for all QoS flows.
	If the category is set to "immediate reporting"	Charging Data Request [Update]
	If the PDU session is still active	Start new counts with time stamps for all active QoS flows
Expiry of data volume limit per PDU session	If the corresponding trigger is enabled	Close the counts with time stamps for all QoS flows.
	If the category is set to "immediate reporting"	Charging Data Request [Update]
	If the PDU session is still active	Start new counts with time stamps for all active QoS flows
Expiry of a limit of number of charging condition changes per PDU session	If the corresponding trigger is enabled	Close the counts with time stamps for all QoS flows.
	If the category is set to "immediate reporting"	Charging Data Request [Update]
	If the PDU session is still active	Start new counts with time stamps for all active QoS flows



Chargeable event	Conditions	SMF action
Management intervention		Charging Data Request [Update] Close the counts with time stamps for all QoS Flows
	If the PDU session is still active	Start new counts with time stamps
Abort		Charging Data Request [Termination] Close the counts with time stamps

The CDR generation mechanism processed by the CHF upon receiving Charging Data Request [Initial, Update, Termination] issued by the SMF for these chargeable events in QBC, is specified in clause 5.2.3.

### 5.2.1.7 Roaming QoS flow Based charging (QBC)

When QoS flow Based Charging specified in 5.2.1.6 is used in a context of roaming, a "Roaming Charging Profile" is defined to allow, when shared, QBC synchronized between both PLMNs and includes:

- The set of chargeable events as per Table 5.2.1.6.1 and associated category.
- The set of thresholds for chargeable events based on trigger thresholds.
- An indication on whether the "Default partial record" or the "Individual partial record" mechanism per clause 5.2.3, is used by CHF.

A default "Roaming Charging Profile" is specified for the SMF and comprises:

- The set of chargeable events and associated category specified as the default per Table 5.2.1.6.1.
- The default set of thresholds configured in the Charging Characteristics for QBC.
- The "Default partial record" mechanism indicated as the one used by CHF.

In the VPLMN, at PDU session establishment or PDU session transfer from a different VPLMN, the default "Roaming Charging Profile" in the new V-SMF may optionally be overridden by a new "Roaming Charging Profile" supplied by the CHF in the Charging Data Response [Initial] with:

- updated set of chargeable events and associated category.
- updated thresholds for chargeable events based on trigger thresholds.
- the selected partial record mechanism ("Default partial record" or "Individual partial record").

This updated "Roaming Charging Profile" is transferred from the new V-SMF to the H-SMF and may be acknowledged or replaced by the HPLMN selected "Roaming Charging Profile" to be used by the new V-SMF.

In the HPLMN, at PDU session establishment or V-SMF change for a PDU session, the "Roaming Charging Profile", when received by the H-SMF from the new V-SMF, may be updated by the CHF in the HPLMN in the Charging Data Response [Initial] to H-SMF. This HPLMN CHF selected "Roaming Charging Profile" is used by the H-SMF and transferred towards the VPLMN.

The "Roaming Charging Profile" resulting from the exchange between the VPLMN and HPLMN at PDU session establishment shall remain unchanged during the PDU session lifetime, unless there is a V-SMF change.

At each V-SMF change in Home routed scenario, the "Roaming Charging Profile" may be renegotiated between the VPLMN and HPLMN and shall remain unchanged during the PDU session lifetime with the actual V-SMF.

The capability specified in clause 5.2.1.2.1 for the CHF to be able to update the triggers after the PDU session is established for a given VPLMN shall not be applicable for Roaming QBC.

### 5.2.1.8 Termination action

The termination action applies only in case of online charging, i.e. quota management is active. It indicates the action, which the UPF should perform when no quota is granted. A packet for a specific rating group is subject to a termination action in the following cases:

- Zero units have been granted;
- The final granted units have been used;
- Quota limit reached;
- End user service rejected;
- End user service denied;
- Rating failed.

The defined termination actions include:

- Allowing the packets to pass through;
- Dropping the packets;
- The SMF Default Termination Action;
- The re-direction of packets to an application server (e.g. defined in the termination action).

NOTE Such a re-direction may trigger a new charging session to be initiated.

A Default Termination Action for all rating groups, for which no quota is granted and there is no specific termination action, shall be pre-configured in the SMF according to operator's policy. For instance, the default behaviour may consist of allowing packets of any terminated service to pass through the UPF.

When final units are granted for a given rating group, the CHF shall provide a termination action using finalUnitAction for this rating group. For the rating group, the CHF provided termination action shall be used instead of SMF pre-configured termination action for "The final granted units have been used" case.

### 5.2.1.9 Sponsored data connectivity charging

The Sponsor Identifier and Application Service Provider Identifier are provided for sponsored data connectivity to the PCF from the AF, according to TS 23.503 [215].

The Sponsor Identifier and Application Service Provider Identity may be included in PCC rules with "offline" charging method for non-roaming or home routed roaming scenarios from the PCF to the SMF. In this case, charging information collected by the SMF includes the Sponsor Identity and the Application Service Provider Identity. Correlation of charging information from multiple users per sponsor and/or application service provider can then be based on Sponsor Identity and Application Service Provider Identity.

### 5.2.1.10 Branching point or UL CL controlled by I-SMF

The interaction between I-SMF and SMF for the support of traffic offload by UPF controlled by the I-SMF is specified in the clause 5.34.6 TS 23.501[200].

There are two cases related to quota management when the granted quota is volume for multiple UPFs and per Operator's policy for the scenarios, i.e. Addition, Removal and Change of PDU Session Anchor (PSA2), Branching Point or UL CL controlled by I-SMF, the traffic is counted in more than one UPF:

- Quota shared by UPFs (PSA)
- Quota granted for each UPF (PSA)

In the scenario UL CL/BP controlled by I-SMF, the I-SMF forwards traffic usage information of UPF (PSA2) to the SMF as specified clause 5.34.4 and clause 5.34.5 in TS 23.501 [200].

### 5.2.1.11 CHF-Controlled Quota Management

Quota management process is initiated by NF consumer, e.g. SMF, for service data flows handled with the online charging method for a given Rating Group. For the provision of the service to the end user, NF consumer requests quota from CHF via Charging Data Request messages [Initial / Update]. CHF-Controlled Quota Management in this context allows CHF to suspend/resume the quota management process for that Rating Group within a PDU session.

When an NF consumer issues a Charging Data Request [Initial / Update] CHF may decide to authorize the service and suspend the quota management for that Rating Group. This means that: the service is authorized without granted units and that all quota management triggers for that Rating Group within a PDU session are ignored by the NF consumer. Usage will continue to be reported via the remaining default active triggers. It is the sole responsibility of CHF to activate other applicable triggers if additional reporting is needed.

When an NF consumer issues a Charging Data Request [Update] in which a given Rating Group has quota management previously suspended, CHF may decide to resume quota management for that Rating Group. This means that all previously set quota management triggers for that Rating Group are considered by the NF consumer and granted units are reconfigured by the CHF.

CHF may want to resume quota management at any time, for this Re-authorization mechanisms can be used to trigger NF consumer to subsequently issue a Charging Data Request [Update]. Procedures enabling CHF-Controlled Quota Management to suspend/resume the quota management are described in TS 32.290 [57].

### 5.2.1.12 URLLC Charging

The CHF can be aware of redundant transmission type (i.e. dual connectivity, redundant transmission on N3/N9 and redundant transmission at transport layer) and provide the quota allocation based on the redundant transmission type:

- For dual connectivity based end to end redundant user plane paths, the granted quotas is allocated for each PDU session.
- For the redundant transmission on N3/N9 interfaces, the CHF grants the quota regardless if packets were duplicated or not.
- For the redundant transmission at transport layer, the CHF grants the quota regardless if packets were duplicated or not.

For dual connectivity based end to end Redundant User Plane Paths, SMF shall collect and report the usage for each redundant PDU session.

For redundant transmission at N3/N9 interface, the SMF shall collect and report the usage not counting redundant packets.

During the PDU session life, the SMF may decide to active or deactivate the redundant transmission and reports the usage based on the redundant transmission change trigger.

For redundant Transmission at transport layer, the SMF shall collect and report the usage not counting redundant packets.

### 5.2.1.13 NR REDCAP Charging

The SMF provides for NR RedCap UE using NR the RAT Type NR\_REDCAP, according to clause 5.41 of TS 23.501 [200].

### 5.2.1.14 Additional actor (MVNO) Charging

#### 5.2.1.14.1 General

The SMF provides charging information collection and reporting per PDU session for 5G non-roaming Mobile Virtual Network Operators (MVNOs) charging, according to clause 5.5.3.10 of TS 32.240 [1].

The charging principle for local breakout roaming scenario is applied to MVNOs (with an A-CHF) charging, with the following differences on the SMF interactions with the CHF in the MNO and A-CHF in the MVNO:

- V-SMF in V-PLMN is replaced by the SMF in MNO;
- V-CHF in V-PLMN is replaced by the CHF in MNO;
- H-CHF in H-PLMN is replaced by the A-CHF in MVNO.

NOTE: CHF selection as well as trigger handling and negotiation, are not specified and may be deployment dependent.

## 5.2.2 Message flows

### 5.2.2.1 General

The flows in the present document specify the interaction between the SMF and the CHF for 5G data connectivity converged charging functionality, in different scenarios, based on TS 23.501 [200] and TS 23.502 [201] procedures and flows.

This interaction is based on Charging Data Request /Response specified in TS 32.290 [57], exchanged between the SMF embedding the CTF and the CHF.

As a general principle, the steps in the figures for the message flows below correspond to the steps of figures in TS 23.502 [201], which is the reference. This document specifies the charging specific extension part.

### 5.2.2.2 PDU session charging from SMF

#### 5.2.2.2.1 General

The subclause below describes PDU session charging in non-roaming scenarios.

#### 5.2.2.2.2 PDU session establishment

The following figure 5.2.2.2.2-1 describes a PDU session establishment charging, based on figure 4.3.2.2.1.1 TS 23.502 [202] description:

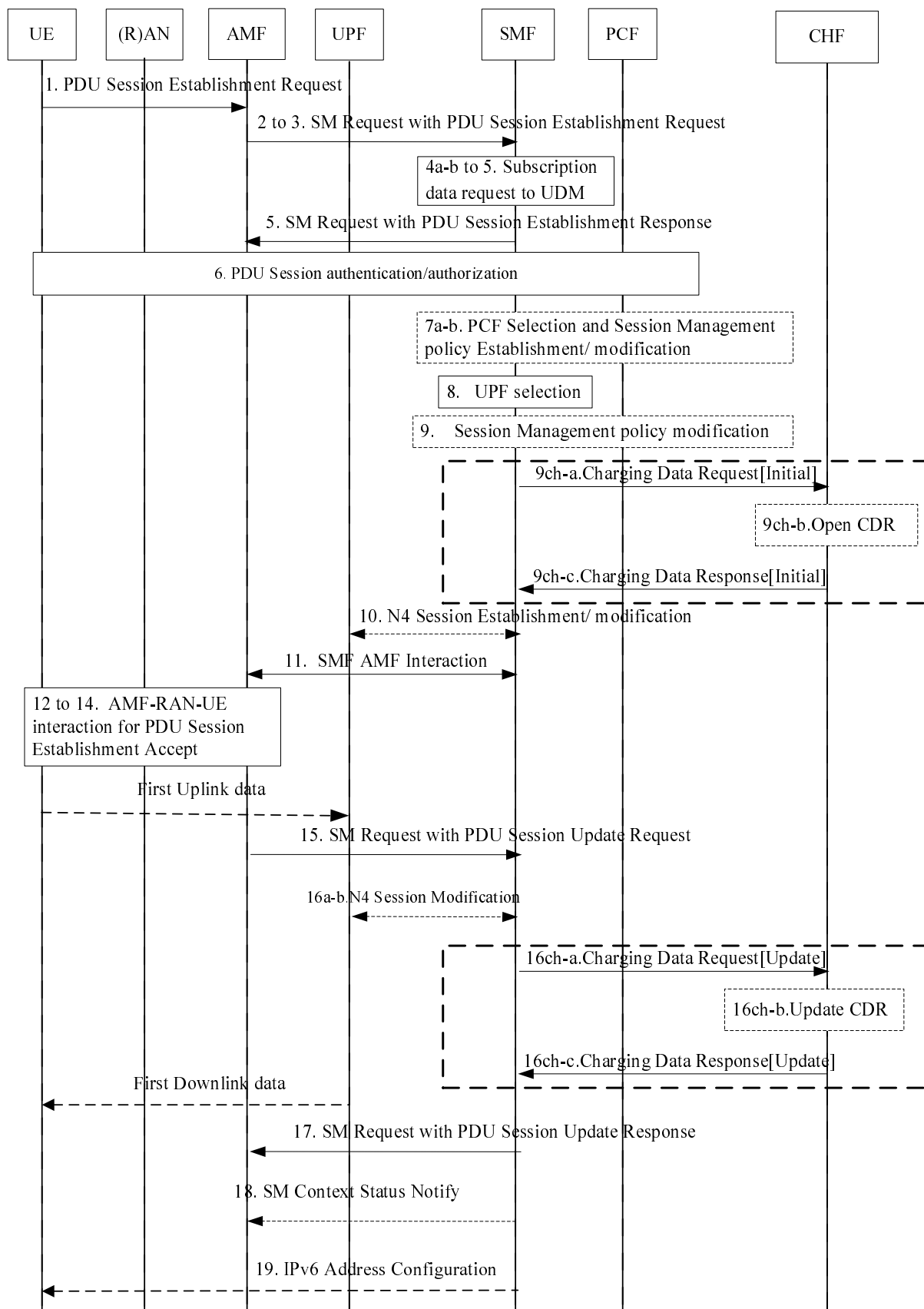

Figure 5.2.2.2-1: PDU session establishment

8. The SMF selects an SSC mode for the PDU Session and also selects one or more UPFs.

9. The SMF may perform a Session Management Policy Modification procedure to report some event to the PCF that has previously subscribed.

9ch-a. The SMF creates a Charging Identifier for the PDU session, and sends Charging Data Request[initial] to CHF for authorization for the subscriber to start the PDU session which is triggered by start of PDU session charging event (The SMF may include 5GS CIoT optimizations information, see TS 23.502 [201]).

9ch-b. The CHF opens CDR for this PDU session.

9ch-c. The CHF acknowledges by sending Charging Data Response[Initial] to the SMF.

15. AMF to SMF: SM Request (N2 SM information).

[16a-b]. N4 session Modification.

16ch-a. This step may occur in case "start of service data flow" needs quota from CHF, for the SMF to request quota.

16ch-b. The CHF updates CDR for this PDU session.

16ch-c. The CHF acknowledges by sending Charging Data Response[Update] to the SMF.

NOTE 1: The steps from 16ch-a to 16ch-c for quota request from CHF are not applicable for offline only charging.

17. SM Request with PDU session Update Response to AMF.

18. SMF sends SM Context Status Notify to AMF.

19. In case of PDU Type IPv6, IPv6 Address Configuration.

#### 5.2.2.2.3 PDU Session Modification

The following figure 5.2.2.2.3-1 describes the PDU session modification charging, based on figure 4.3.3.2-1 TS 23.502 [202] description:

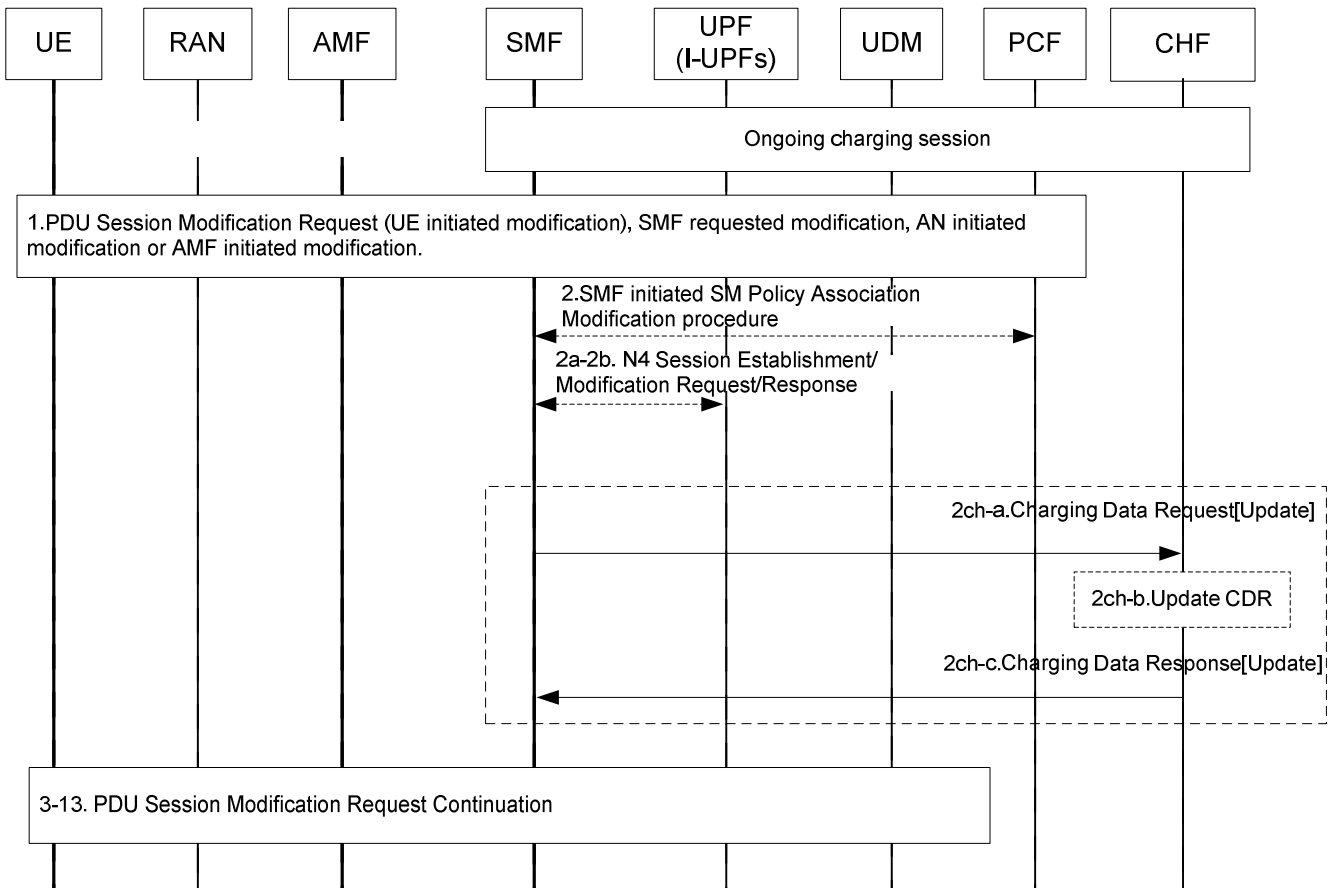

**Figure 5.2.2.2.3-1: PDU Session Modification**

2ch-a. The SMF sends Charging Data Request [Update] to the CHF for reporting the charging information when the corresponding trigger is armed.

2ch-b. The CHF update the CDR for the PDU session.

2ch-c. The CHF acknowledges by sending Charging Data Response [Update] to the SMF.

**5.2.2.2.4 PDU Session Release**

The following figure 5.2.2.2.4-1 describes the PDU session release charging, based on figure 4.3.4.2-1 TS 23.502 [202] description:

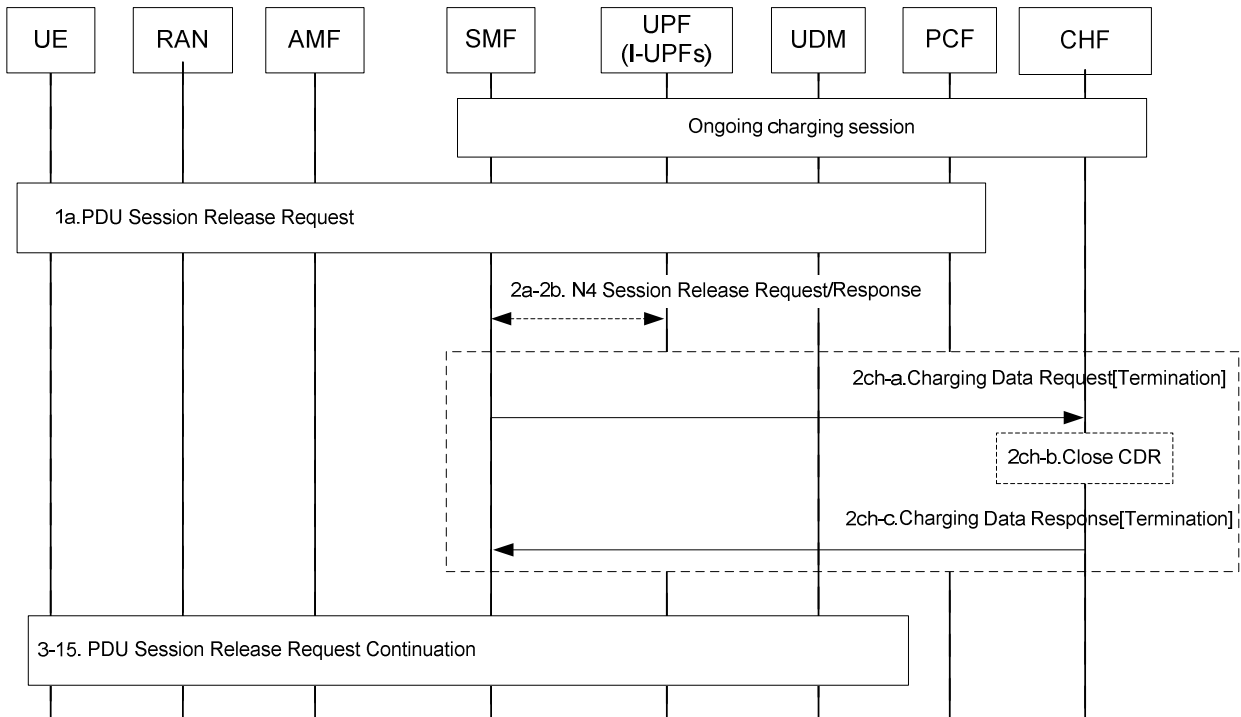

**Figure 5.2.2.4-1: PDU Session Release**

2ch-a. The SMF sends Charging Data Request [Termination] to the CHF for terminating the charging associated with PDU sessions, with the trigger "End of PDU session".

2ch-b. The CHF closes the CDR for the PDU session.

2ch-c. The CHF acknowledges by sending Charging Data Response [Termination] to the SMF.

### 5.2.2.3 PDU session charging SSC Mode 1 from SMF

#### 5.2.2.3.1 General

The subclause below describes PDU session SSC mode 1 charging in non-roaming scenarios.

#### 5.2.2.3.2 PDU session charging SSC Mode 1

The following figure 5.2.2.3.2.1 describes a PDU session SSC mode 1 charging, based on clause 5.6.9.2.1 TS 23.501 [201] description:



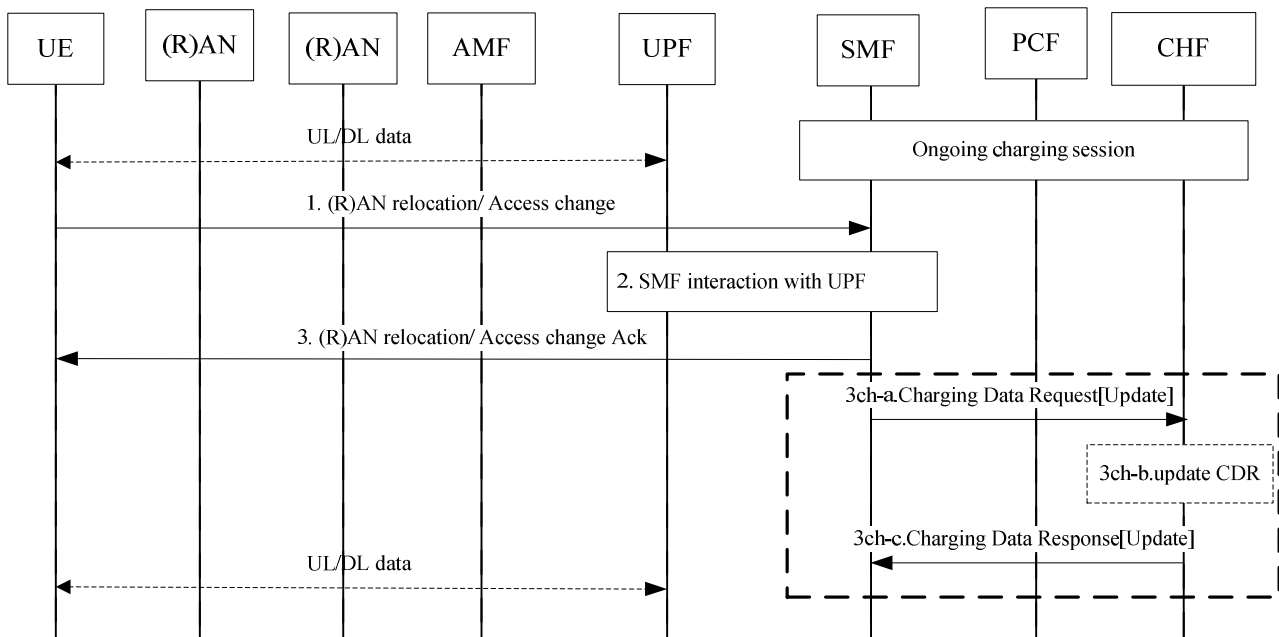

**Figure 5.2.2.3.2.1: (R)AN relocation for PDU session in SSC mode 1**

Ongoing charging interaction associated with the established PDU session (UPF).

1. A (R)AN relocation is performed.
2. The SMF determines that the serving UPF needs to be maintained and interacts with the UPF for the path switch to the new (R)AN access.
3. the SMF acknowledges the path switch to the new (R)AN.
- 3ch-a. The SMF sends Charging Data Request[Update] to the CHF for reporting the charging information User location information/ Access Technology Type Information.
- 3ch-b. The CHF updates the CDR.
- 3ch-c. The CHF acknowledges by sending Charging Data Response[Update] to the SMF.

## 5.2.2.4 PDU session Charging SSC Mode 2 from SMF

### 5.2.2.4.1 General

The subclause below describes PDU session charging for change the PDU Session Anchor serving a PDU Session of SSC mode 2

#### 5.2.2.4.2 PDU session Charging SSC Mode 2

The following figure 5.2.2.4.2.1 describes a PDU session anchor relocation in SSC mode 2 charging, based on figure 4.3.5.1.1 TS 23.502 [201] description:

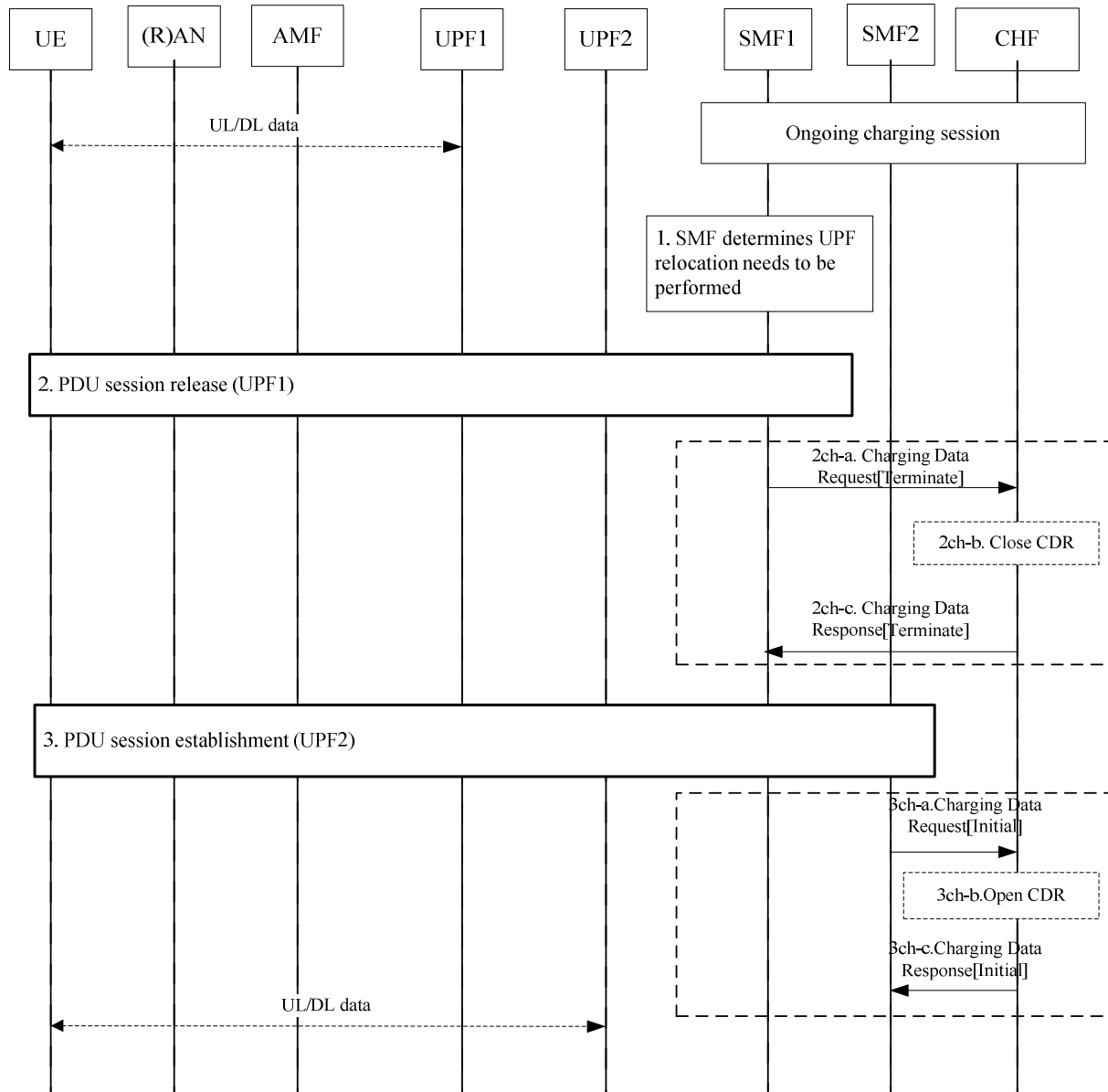

**Figure 5.2.2.4.2.1: PDU session anchor relocation in SSC mode 2 with single PDU session anchor**

Ongoing charging session associated with the established PDU session (UPF1)

2. PDU session release procedure (UPF1).

2ch-a. The SMF1 sends Charging Data Request[Termination] to the CHF for terminating the charging associated with old PDU session in UPF1.

2ch-b. The CHF closes the CDR for old PDU session in UPF1.

2ch-c. The CHF acknowledges by sending Charging Data Response[Termination] to the SMF1.

3. PDU session establishment procedure (UPF2).

3ch-a. The SMF2 creates a Charging Identifier for new PDU session ID in UPF2 and sends Charging Data Request[initial] to CHF for authorization for the subscriber to start the new PDU session which is triggered by start of PDU session charging event.

3ch-b. The CHF opens CDR for new PDU session in UPF2.

3ch-c. The CHF acknowledges by sending Charging Data Response[initial] to the SMF2.

NOTE: If the same SMF1 is re-selected in step 3, the same steps 3ch-a to b apply to SMF1

### 5.2.2.5 PDU session Charging SSC Mode 3 from SMF

#### 5.2.2.5.1 General

The subclause below describes PDU session charging for change the PDU Session Anchor serving a PDU Session of SSC mode 3.

#### 5.2.2.5.2 PDU session Charging SSC Mode 3

The following figure 5.2.2.5.2.1 describes a PDU session anchor relocation in SSC with mode 3 multiple PDU sessions and SMF reallocation, based on figure 4.3.5.2.1 TS 23.502 [201] description:

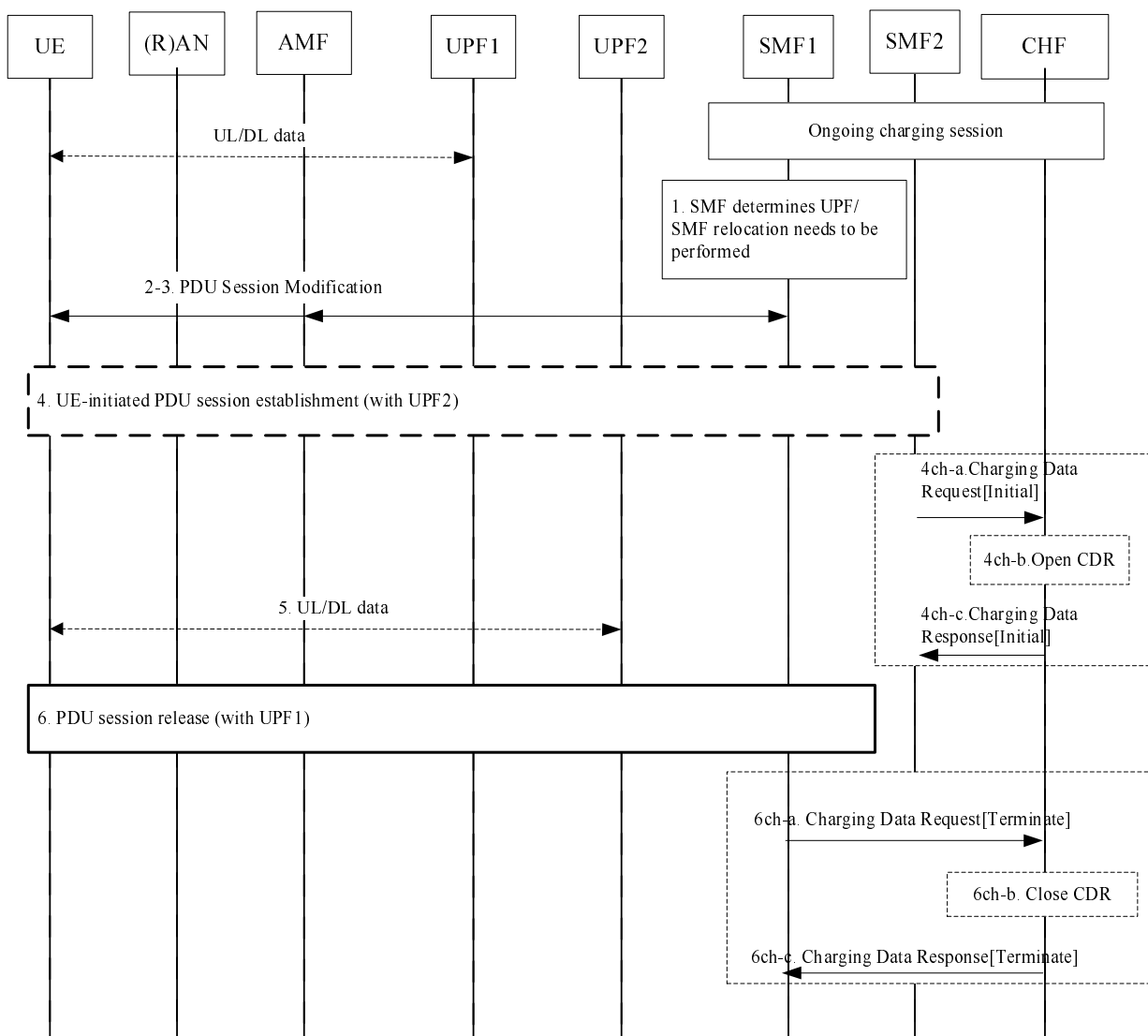

**Figure 5.2.2.5.2.1: PDU session anchor relocation in SSC mode 3 with multiple PDU sessions – SMF reallocation**

Ongoing charging interaction associated with the established PDU session (with UPF1).

4. UE initiates PDU session establishment procedure with UPF2.

4ch-a. The SMF2 creates a Charging Identifier for new PDU session ID with UPF2 and sends Charging Data Request[initial] to CHF for authorization for the subscriber to start the new PDU session (with UPF2) which is triggered by start of PDU session charging event.

4ch-b. The CHF opens CDR for new PDU session in UPF2.

4ch-c. The CHF acknowledges by sending Charging Data Response[initial] to the SMF2.

6. Old PDU session for UPF1 release.

6ch-a. The SMF1 sends Charging Data Request[Termination] to the CHF for terminating the charging associated with old PDU session in UPF1.

6ch-b. The CHF closes the CDR for old PDU session in UPF1.

6ch-c. The CHF acknowledges by sending Charging Data Response[Termination] to the SMF1.

## 5.2.2.6 PDU session Charging SSC Mode 3 IPv6 Multi Homed from SMF

### 5.2.2.6.1 General

The subclause below describes PDU session charging for service continuity with SSC mode 3 using the multi-homed PDU Session.

### 5.2.2.6.2 PDU session Charging SSC Mode 3 IPv6 Multi Homed

The following figure 5.2.2.6.2.1 describes a PDU session anchor relocation in SSC mode 3 with IPv6 Multi homed PDU Session charging, based on figure 4.3.5.3.1 TS 23.502 [201] description:

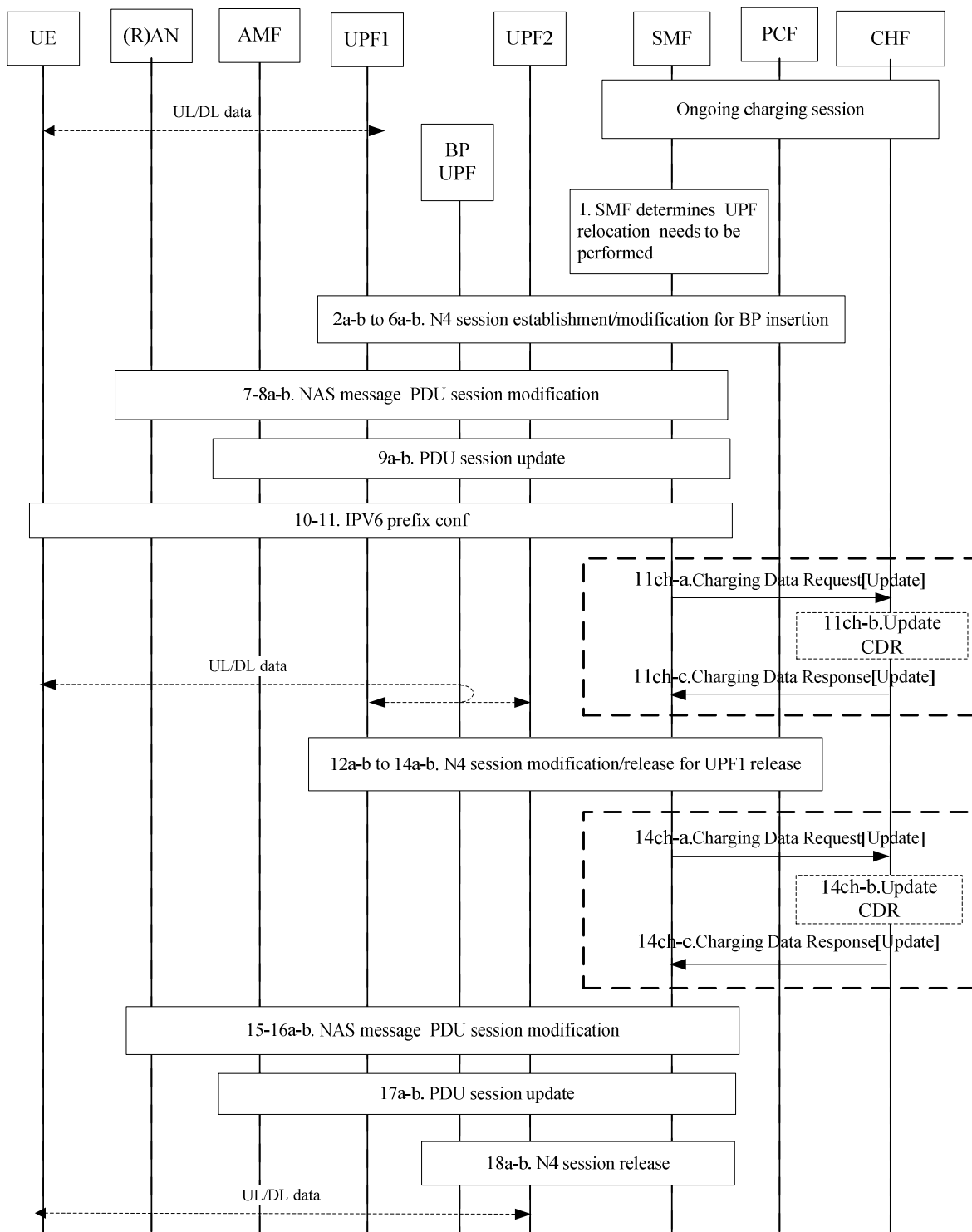

**Figure 5.2.2.6.2.1: PDU session anchor relocation in SSC mode 3 with IPv6 Multi homed PDU Session**

Ongoing charging interaction associated with the established PDU session (UPF1).

Traffic starts at UPF2.

11ch-a. The SMF sends Charging Data Request[Update] to the CHF for request quota for UPF2 which is triggered by start of service data flow charging event, if quota management per UPF.

11ch-b. The CHF updates CDR for this PDU session

11ch-c. The CHF acknowledges by sending Charging Data Response[Update] to the SMF.

[12a-b to 13a-b] The SMF releases the UE's old IPv6 prefix (IP@1), and releases the path between BP UPF and UPF1.

13ch-a. The SMF sends Charging Data Request[Update] to the CHF for usage reporting for UPF1 which is triggered by termination of service data flow charging event, if quota management per UPF.

13ch-b. The CHF updates CDR for this PDU session.

13ch-c. The CHF acknowledges by sending Charging Data Response[Update] to the SMF.

In this scenario, the PDU session Id is maintained during the whole procedure.

### 5.2.2.7 Addition of additional PDU Session Anchor and Branching Point or UL CL

The following figure 5.2.2.7.1 describes the charging procedure to add a PDU Session Anchor and a Branching Point or UL CL for an established PDU Session, based on figure 4.3.5.4.1 TS 23.502[201].

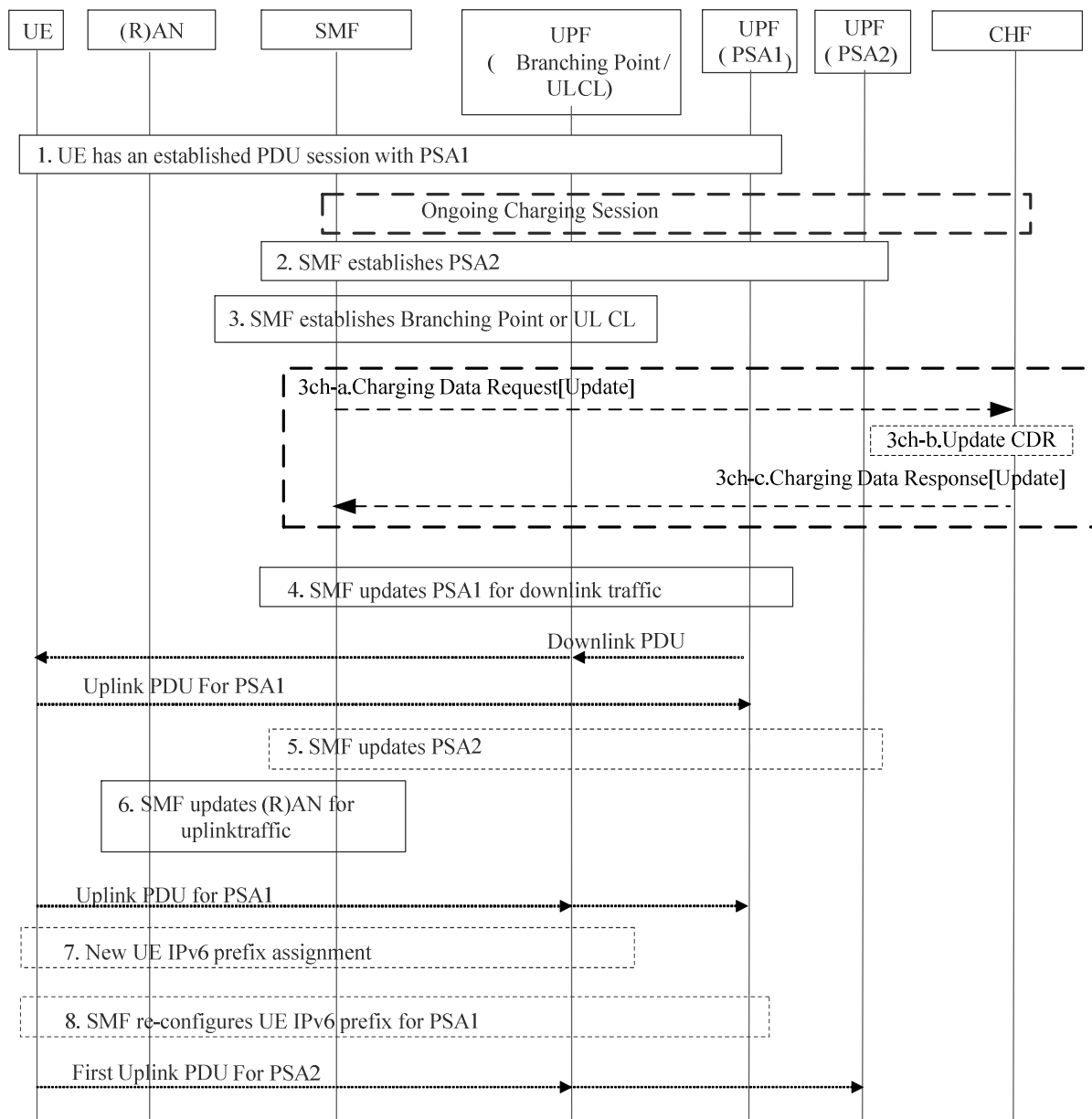

Figure 5.2.2.7.1: Addition of additional PDU Session Anchor and Branching Point or UL CL

Ongoing charging interaction associated with the established PDU session (UPF).

3. The SMF establishes the Branching Point (in case of IPv6 multi-homing) or a UL CL for the PDU Session.

3ch-a. The SMF sends Charging Data Request[Update] to the CHF for the additional of UPF (PSA 2) if quota management is granted per UPF by trigger "Addition of UPF".

3ch-b. The CHF updates the CDR for the charging information of UPF (PSA 2).

3ch-c. The CHF acknowledges by sending Charging Data Response[Update] to the SMF.

### 5.2.2.8 Removal of additional PDU Session Anchor and Branching Point or UL CL

The following figure 5.2.2.8.1 describes charging procedure to remove a PDU Session Anchor and (optionally) remove Branching Point or UL CL for an established PDU Session, based on figure 4.3.5.5.1 TS 23.502[201].

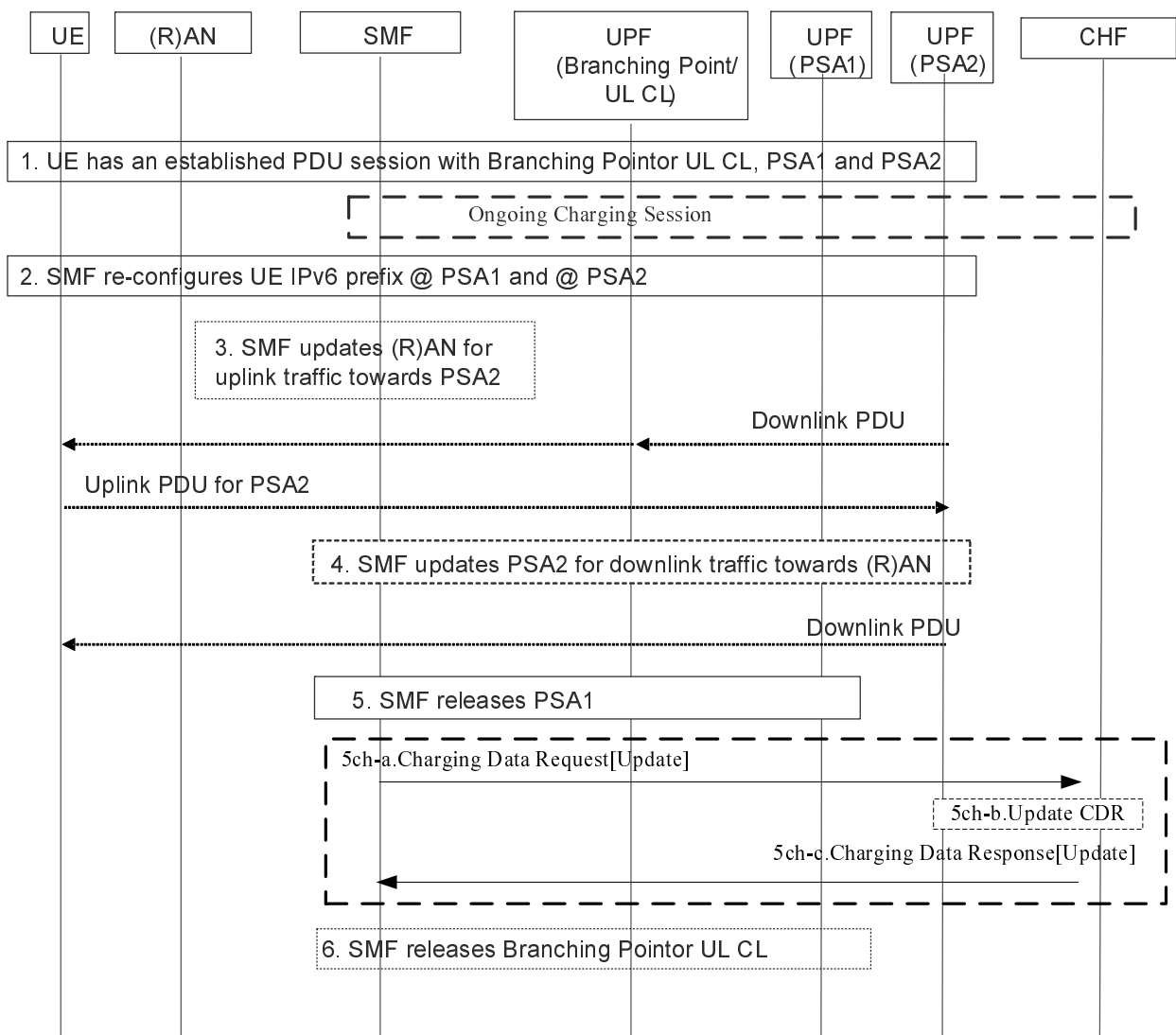

**Figure 5.2.2.8.1: Removal of additional PDU Session Anchor and Branching Point or UL CL**

Ongoing charging interaction associated with the established PDU session (UPF).

5. The SMF releases via N4 the PSA1.

5ch-a. The SMF sends Charging Data Request[Update] to the CHF for the removal of UPF (PSA 1) if quota management is granted per UPF by trigger "Removal of UPF".

5ch-b. The CHF updates the CDR for the charging information of UPF (PSA 1).

5ch-c. The CHF acknowledges by sending Charging Data Response[Update] to the SMF.

6. If steps 4 and 5 were executed, the SMF releases the Branching Point / UL CL.

### 5.2.2.9 Change of additional PDU Session Anchor for IPv6 multi-homing or UL CL

The following figure 5.2.2.9.1 charging procedure to establish a new additional PDU Session Anchor (i.e., PSA2) and conditionally releases the existing additional PDU Session Anchor (i.e. PSA1), while modifying IPv6 multi-homing or UL CL rule in the same Branching Point or UL CL under controlled by the same SMF abased on figure 4.3.5.6.1 TS 23.502[201].

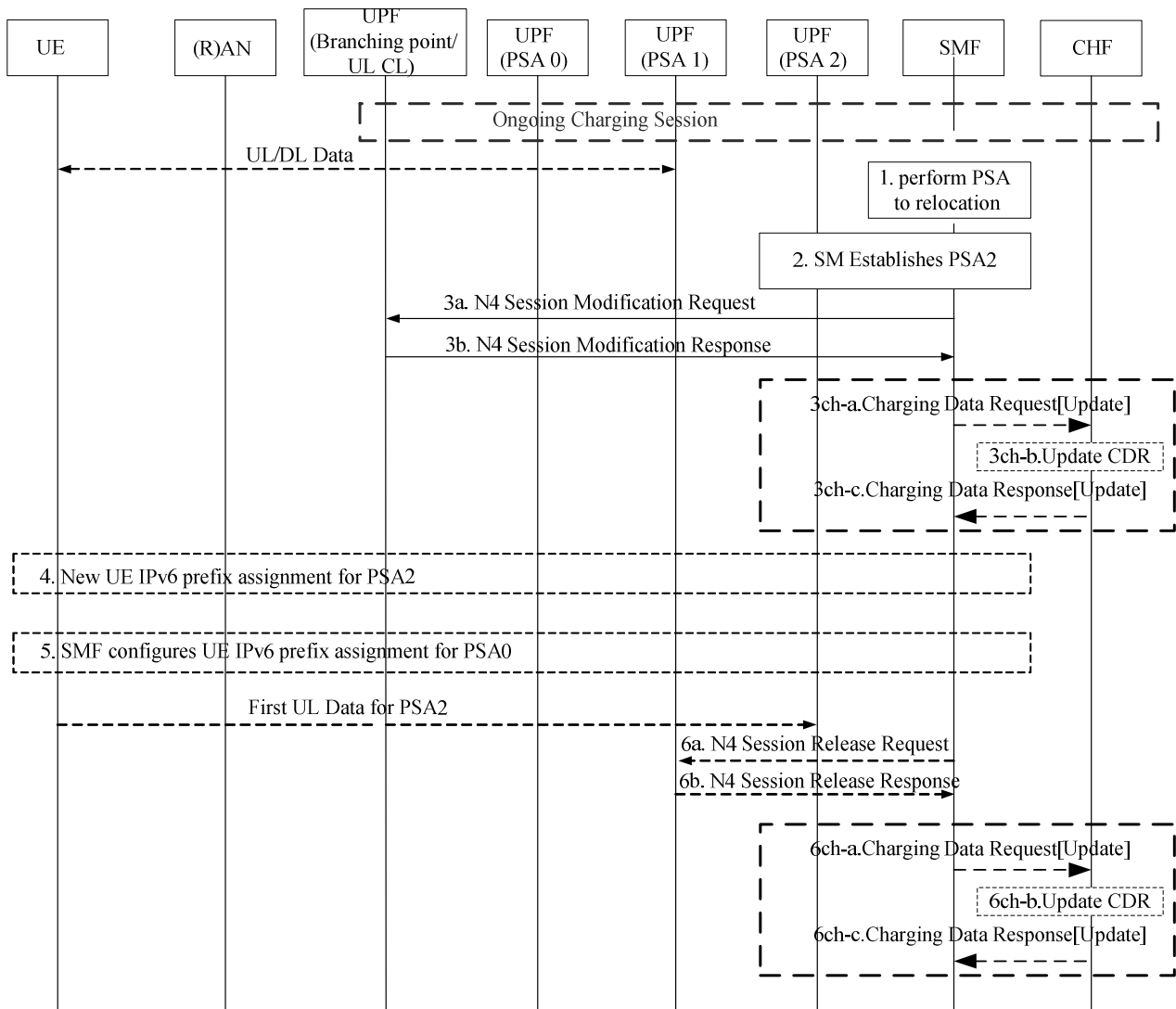

**Figure 5.2.2.9.1: Change of additional PSA for a PDU Session in IPv6 multi-homing or UL CL case**

Ongoing charging interaction associated with the established PDU session (UPF).

3a-b. The SMF exchange the N4 message to Branching Point or UL CL .

3ch-a. The SMF sends Charging Data Request[Update] to the CHF for the additional of UPF (PSA 2) if quota management is granted per UPF by trigger "Addition of UPF".

3ch-b. The CHF updates the CDR for the charging information of UPF (PSA 2).

3ch-c. The CHF acknowledges by sending Charging Data Response[Update] to the SMF.



6a-b. Step 6 occurs only if the Branching Point or UL CL does not have any traffic filter on the PDU Session which forwards a traffic flow to PSA1.

6ch-a. The SMF sends Charging Data Request[Update] to the CHF for the removal of UPF (PSA 1) if quota management is granted per UPF by trigger "Removal of UPF".

6ch-b. The CHF updates the CDR for the charging information of UPF (PSA 1).

6ch-c. The CHF acknowledges by sending Charging Data Response[Update] to the SMF.

#### 5.2.2.10 Simultaneous change of Branching Point or UL CL and additional PSA for a PDU Session

The following figure 5.2.2.10.1 describe the charging procedure to change the Branching Point or the UL CL and additional PSA serving a PDU Session for a UE triggered by SMF ((just an example call flow triggered by Xn based handover) based on figure 4.3.5.7.1 TS 23.502[201]).

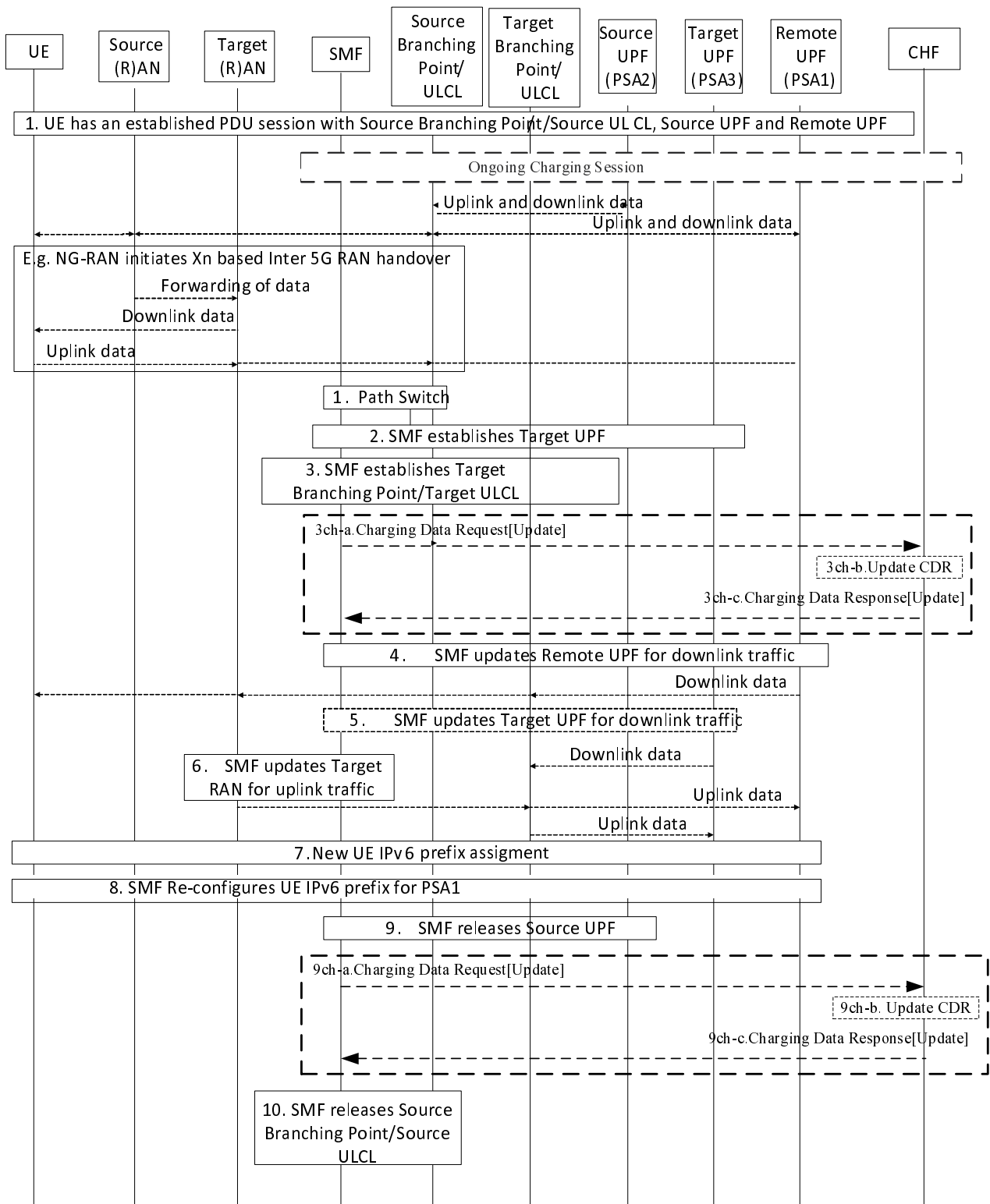

Figure 5.2.2.10.1: Simultaneous change of Branching Point or UL CL and additional PSA for a PDU Session

Ongoing charging interaction associated with the established PDU session (UPF).

3ch-a. The SMF sends Charging Data Request[Update] to the CHF for the additional of Target UPF if quota management is granted per UPF by trigger "Addition of UPF".

3ch-b. The CHF updates the CDR for the charging information of Target UPF.

3ch-c. The CHF acknowledges by sending Charging Data Response[Update] to the SMF.

9. The SMF releases PSA2.

9ch-a. The SMF sends Charging Data Request[Update] to the CHF for the removal of Source UPF if quota management is granted per UPF by trigger "Removal of UPF".

9ch-b. The CHF updates the CDR for the charging information of Source UPF.

9ch-c. The CHF acknowledges by sending Charging Data Response[Update] to the SMF.

## 5.2.2.11 PDU session charging for interworking with EPC

### 5.2.2.11.1 General

In order to interwork with EPC, the N26 interface is introduced as an inter-CN interface between the MME in EPC and 5GS AMF in order to enable provide seamless session continuity for single registration mode UE for inter-system change in the clause 5.17.2.2 TS 23.501[201].

PCF + PCRF, PGW-C + SMF and UPF + PGW-U are dedicated for interworking between 5GS and EPC, which are optional and are based on UE MM Core Network Capability and UE subscription in the clause 4.3 TS 23.501 [201]. The procedures for interworking with EPS based on N26 interface are specified in clause 4.11.1 TS 23.502 [201].

When 5GS and EPC interworking, interaction between the PGW-C + SMF and CHF is using the same interface as for interaction between SMF and CHF.

When a UE establishes a PDN connection/PDU session with PGW-C+SMF in EPS or 5GS, a charging session is established for the PDU session and PDN connection to support 5GS and EPS interworking as follows:

- When a UE is served by EPC, a charging session is established between the PGW-C+SMF and CHF via Nchf interface for EPC online charging and offline charging if 5GS interworking indication from SGW indicates that the UE supports 5G and the PDN connection is not restricted to interworking with 5GS by user subscription.
- When a UE is served by 5GS, a charging session is established between the PGW-C+SMF and CHF via Nchf interface for 5GS converged online and offline charging.
- When a UE is served by EPC, the PGW-C+SMF acts as the PGW and a charging session is established via Gy interface for EPC online charging and Gz interface for offline charging if 5GS interworking is not supported.

The chargeable events for 5GS and EPC interworking are handover cancel, handover start and handover complete.

The triggers for 5GS and EPC interworking may be enabled or disabled, the PGW-C+SMF will interact with charging system as the following:

- If the trigger for interworking is enabled and the category is set to "immediate reporting", the PGW-C+SMF will report usage in source network and/or request quota for target network.
- If the trigger for interworking is enabled and the category is set to "deferred reporting", the PGW-C+SMF will close the count in source network and start a new count in target network, and continue to consume the quota in target network. The source access specific triggers will no more be applicable in the PGW-C+SMF, the target access specific triggers will apply instead.
- If the trigger for interworking is disabled, the PGW-C+SMF will record usage for both source and target network accesses into common count, and consumes the same quota in source and target network. The source access specific triggers will no more be applicable in the PGW-C+SMF, the target access specific triggers will apply instead.

5.2.2.11.2 5GS to EPS handover using N26 interface

The following figure 5.2.2.11.2.1 describes the handover from 5GS to EPS when N26 is supported, based on figure 4.11.1.2.1.1 TS 23.502 [201] description:

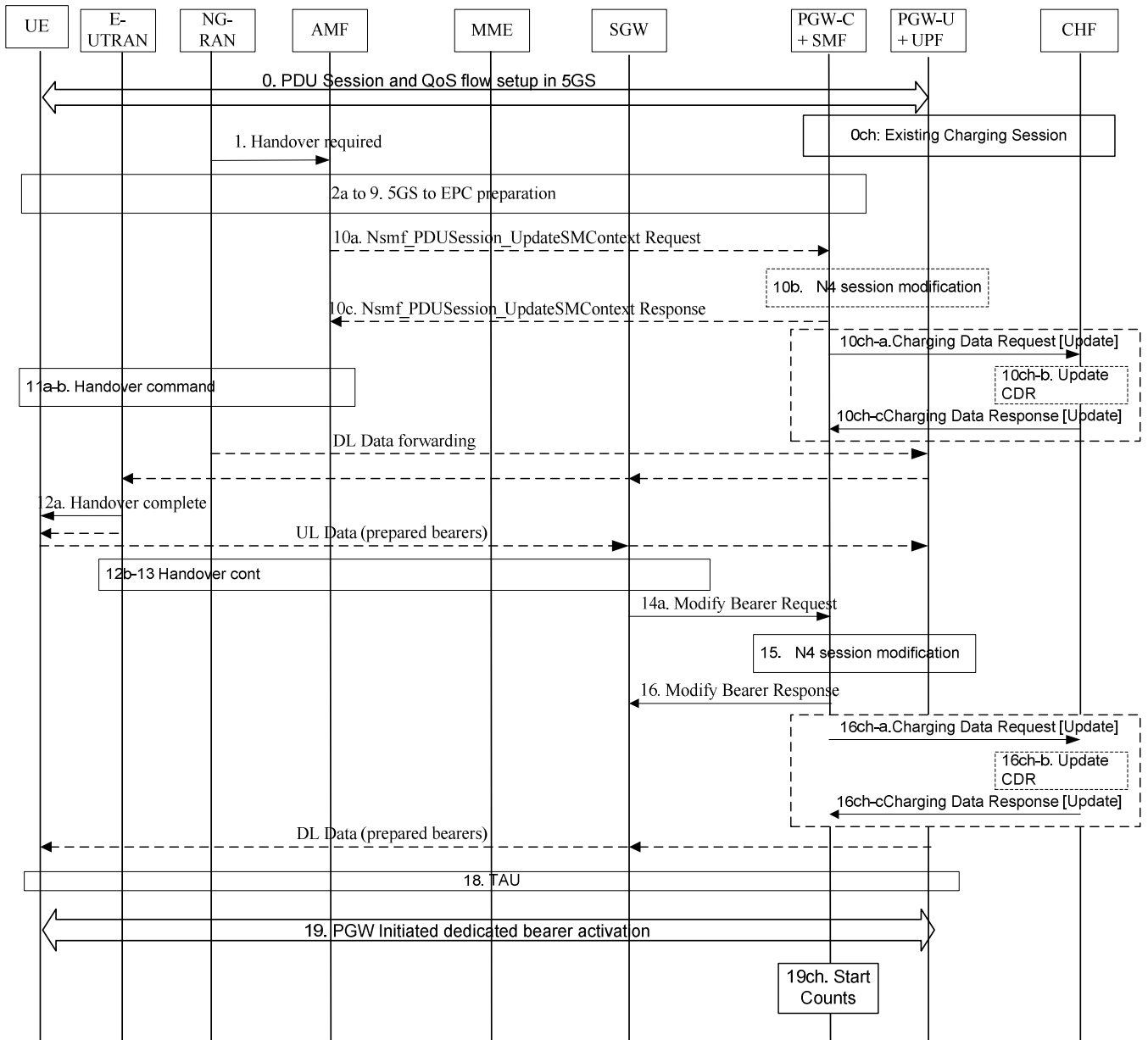

Figure 5.2.2.11.2.1: 5GS to EPS handover using N26

- 0. A PDU session is established in 5GS with multiple QoS Flows. A Charging Identifier was assigned to the PDU session.
- 0ch. A charging session between the PGW-C+SMF and CHF exists for this PDU session.
- 10c. PDU session update response to AMF.
- 10ch-a. This step occurs if steps 10a-c occurred. All counts are closed and a Charging Data Request [Update] is sent to CHF, if required by "Handover start" trigger. New counts and time stamps for all active service data flows are started in the PGW-C+SMF.
- 10ch-b. The CHF updates CDR for this PDU session.
- 10ch-c. The CHF acknowledges by sending Charging Data Response [Update] to the PGW-C+SMF.

16. User Plane path switch for the default bearer and the dedicated GBR bearers between the UE and PGW-U+UPF via SGW. The Charging Identifier assigned to the PDN connection is supplied as the Charging Identifier for the default bearer. The EPS bearer Charging Identifier assigned to the dedicated EPS bearer(s), is supplied as the Charging Identifier for that dedicated EPS bearer.

16ch-a. All counts are closed and a Charging Data Request [Update] is sent to CHF, if required by "RAT type change" trigger. New counts and time stamps for all active service data flows are started in the PGW-C+SMF (The PGW-C+SMF may include APN Rate Control Change, see TS 23.502 [201]).

16ch-b. The CHF updates CDR.

16ch-c. The CHF acknowledges by sending Charging Data Response [Update] to the PGW-C+SMF.

19. Dedicated bearer activation procedure for non-GBR QoS flows initiated by PGW-C+SMF.

19ch. Needed counts are started on start of service data flows of corresponding non-GBR QoS Flows.

### 5.2.2.11.3 EPS to 5GS handover using N26 interface

The following figures 5.2.2.11.3.1 and 5.2.2.11.3.2 describe the handover from EPS to 5GS when N26 is supported, based on figures 4.11.1.2.2.2.1 and 4.11.1.2.2.3.1 TS 23.502 [201] description:

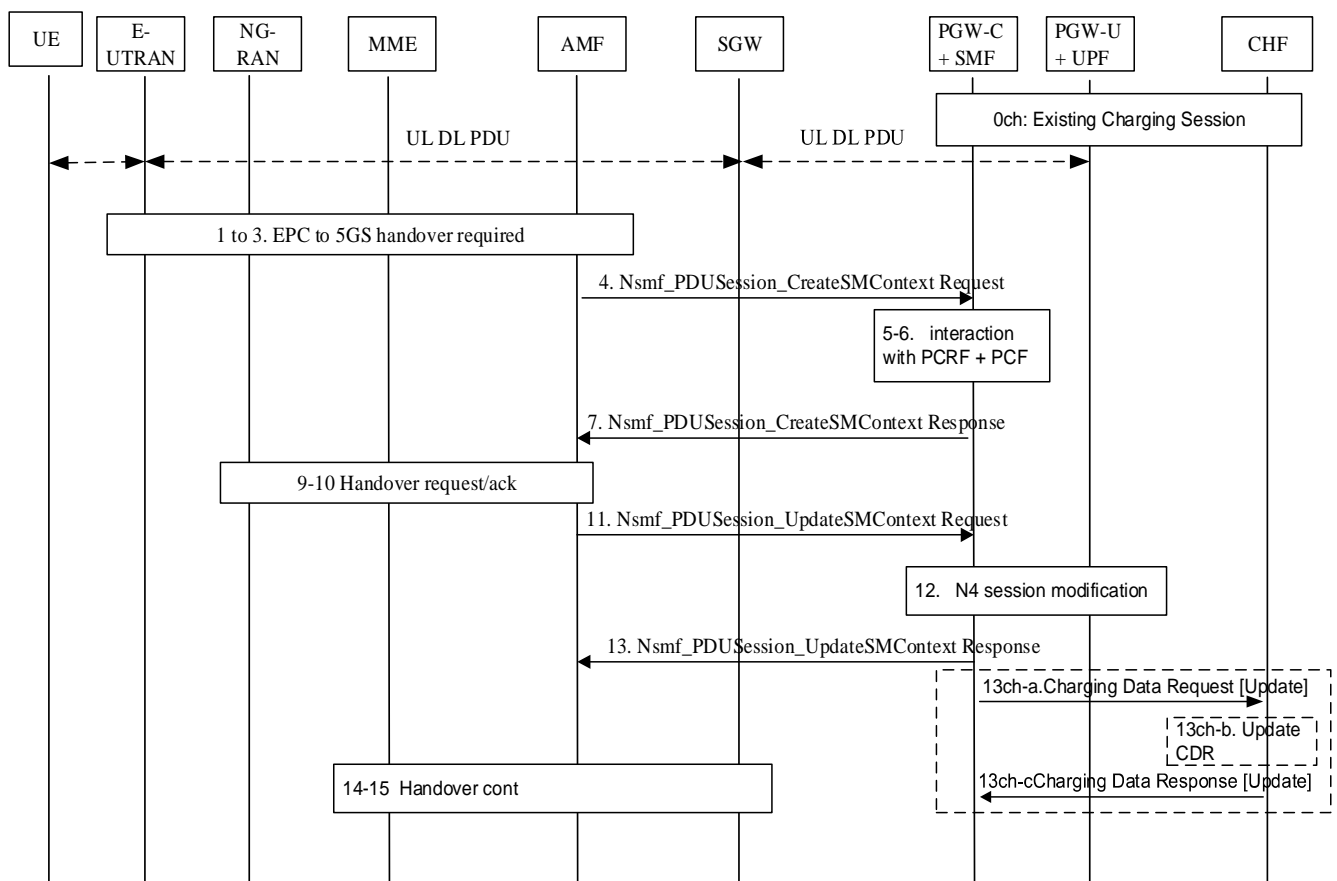

Figure 5.2.2.11.3.1: EPS to 5GS handover using N26 - preparation

0. If the UE supports 5G and the PDN connection is not restricted to interworking with 5GS by user subscription, the PGW-C+SMF is aware that 5GS interworking is supported. A PDN connection is established in EPC with default bearer and dedicated bearers. Association between the EPS bearer and the corresponding 5G QoS Rules is stored by the PGW-C+SMF.

0ch. A charging session between the PGW-C+SMF and CHF exists for this PDN connection with associated to the default bearer and dedicated bearers. The default bearer is assigned with the Charging Identifier of the PDN connection. The dedicated bearers are assigned with the EPS bearer Charging Identifier.

As described in clause 4.11.1.2.2 of TS 23.502 [201] the PGW-C+SMF may receive APN Rate Control Status enabled during interworking with EPC for this PDN connection, the PGW-C+SMF interacts with CHF as following:

13ch-a. All counts are closed and a Charging Data Request [Update] is sent to CHF, if required by "RAT type change" trigger. The APN Rate Control Change may be provided by PGW-C+SMF in charging information if received.

13ch-b. The CHF updates CDR for this PDN connection.

13ch-c. The CHF acknowledges by sending Charging Data Response [Update] to the PGW-C+SMF.

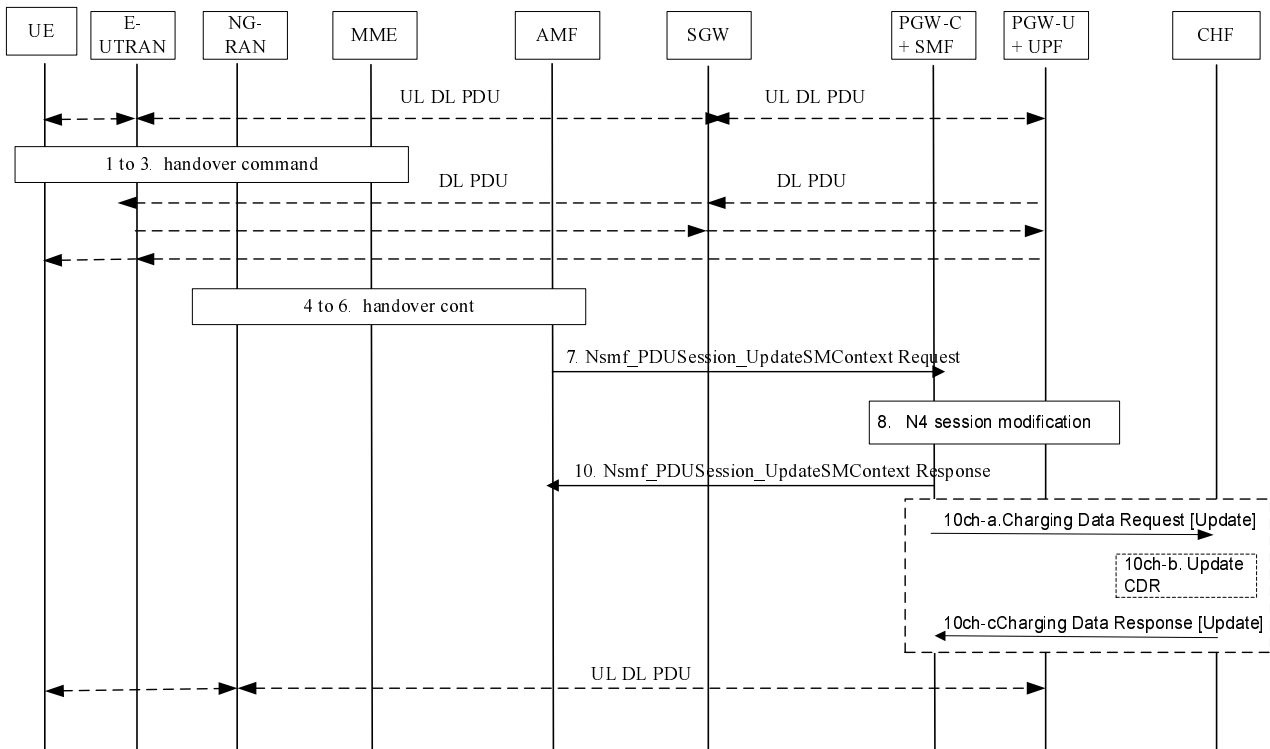

**Figure 5.2.2.11.3.2: EPS to 5GS handover using N26 - execution**

10ch-a. All counts are closed and a Charging Data Request [Update] is sent to CHF, if required by "RAT type change" trigger. New counts and time stamps for all active service data flows are started in the PGW-C+SMF.

10ch-b. The CHF updates CDR for this PDU session.

10ch-c. The CHF acknowledges by sending Charging Data Response [Update] to the PGW-C+SMF.

#### 5.2.2.11.4 Handover Cancel

The following figures 5.2.2.11.4.1 describe the handover cancel, based on clause 4.11.1.2.3 TS 23.502 [201] description:

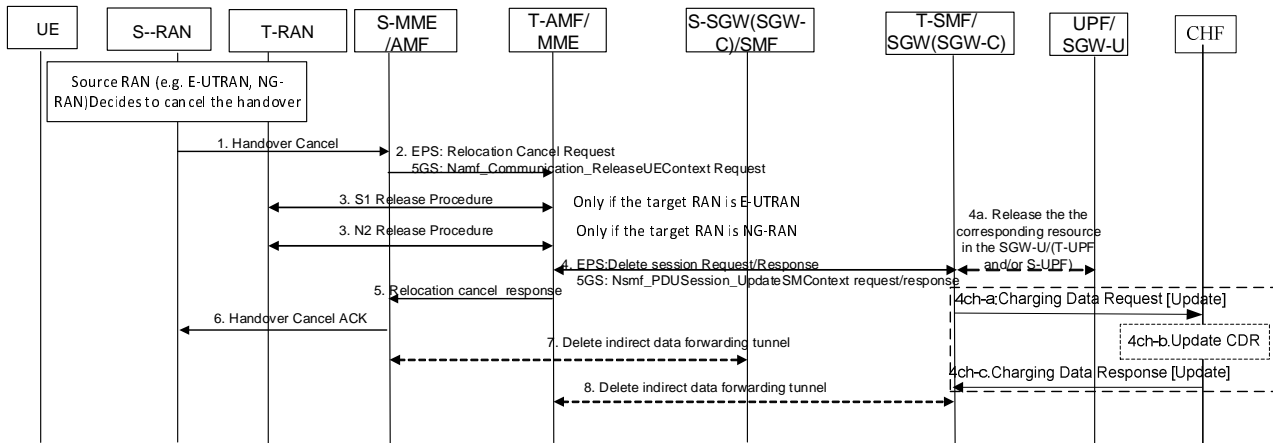
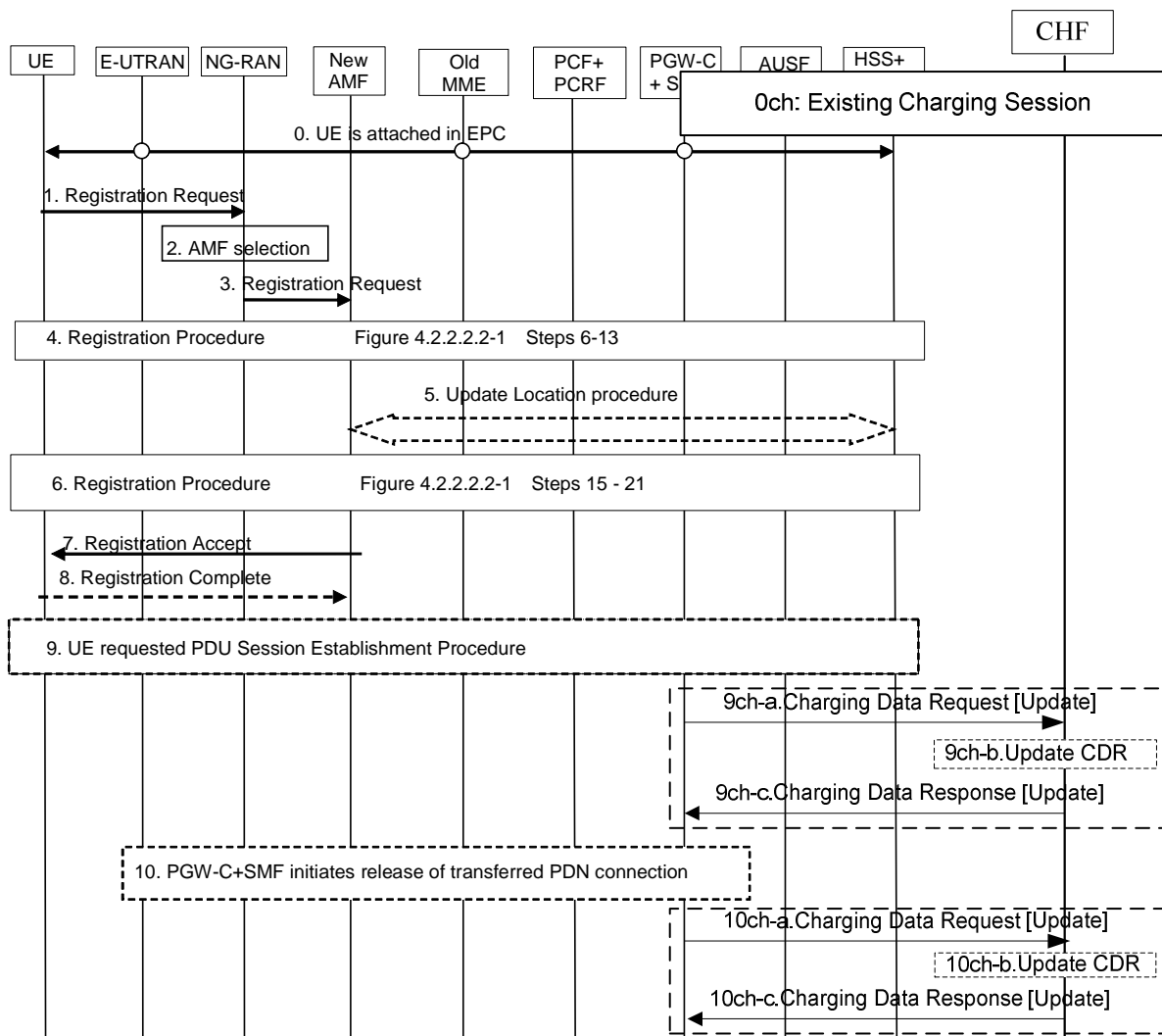

Figure 5.2.2.11.4.1: Handover Cancel

- 4. Based on the Relocation Cancel Indication, the target CN node (MME or AMF) deletes the session resources established during handover preparation phase in SGW (SGW-C and SGW-U)/ (SMF and UPF).
- 4ch-a. All counts are closed and a Charging Data Request [Update] is sent to CHF which triggered by "Handover cancel", New counts and time stamps for all active service data flows are started in the PGW-C+SMF.
- 4ch-b. The CHF updates CDR for this PDU session.
- 4ch-c. The CHF acknowledges by sending Charging Data Response [Update] to the PGW-C+SMF.
- 7. If indirect forwarding tunnel is setup during handover preparation phase then cancellation of handover triggers the source CN node to release the temporary resources used for indirect forwarding.
- 8. If indirect forwarding tunnel is setup during handover preparation phase then cancellation of handover triggers the target CN node to release the temporary resources used for indirect forwarding.

5.2.2.11.5 EPS to 5GS mobility without N26 interface

The following figures 5.2.2.11.5.1 describe the handover from EPS to 5GS without N26 support, based on clause 4.11.2.3 TS 23.502 [201] description:



**Figure 5.2.2.11.5.1: EPS to 5GS mobility without N26**

- 0. The UE is attached in EPC.
- 1-8. UE initiate registration procedure to the 5GS and indicates that it is moving from EPC.
- 9. UE requested PDU Session Establishment.
- 9ch-a. a Charging Data Request [Update] is sent to CHF which is triggered by Handover start charging event, New counts and time stamps for all active service data flows are started in the PGW-C+SMF.
- 9ch-b. The CHF updates CDR for this PDU session.
- 9ch-c. The CHF acknowledges by sending Charging Data Response [Update] to the PGW-C+SMF.
- 10. The PGW-C+SMF performs release of the resources in EPC for the PDN connections(s) transferred to 5GS by performing the PDN GW initiated bearer deactivation procedure.
- 10ch-a. All counts are closed and a Charging Data Request [Update] is sent to CHF which is triggered by Handover complete charging event.
- 10ch-b. The CHF updates CDR.
- 10ch-c. The CHF acknowledges by sending Charging Data Response [Update] to the PGW-C+SMF.



## 5.2.2.11.6 5GS to EPS mobility without N26 interface

The following figures 5.2.2.11.6.1 describe the handover from 5GS to EPS without N26 support, based on clause 4.11.2.2 TS 23.502 [201] description:

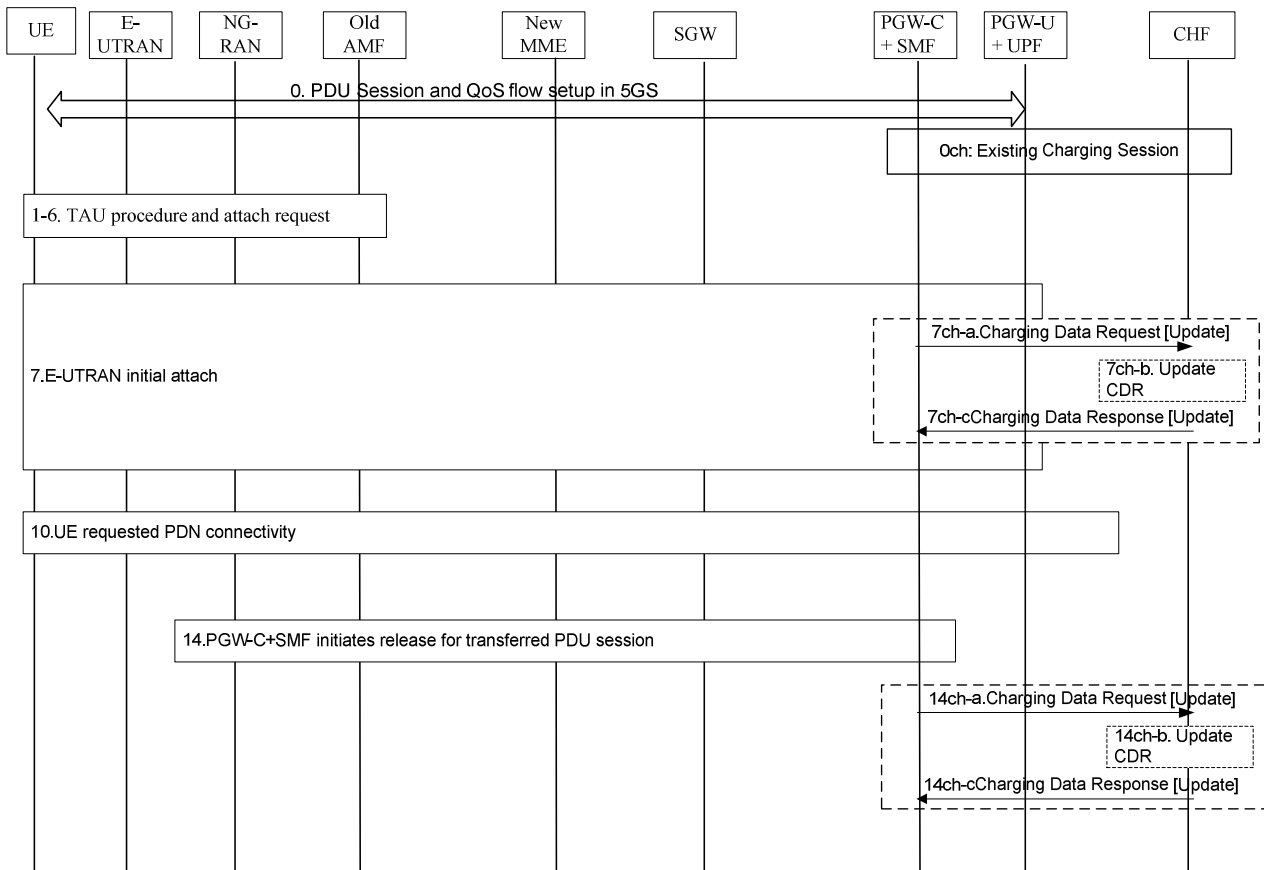

**Figure 5.2.2.11.6.1: 5GS to EPS mobility without N26**

0. UE is registered in 5GS.

1-6. TAU procedure is triggered to start for E-UTRAN initial attach.

7. UE initiate E-UTRAN Initial Attach procedure to the EPS and indicates that it is moving from 5GS.

7ch-a. a Charging Data Request [Update] is sent to CHF which is triggered by Handover start charging event. New counts and time stamps for all active service data flows are started in the PGW-C+SMF.

7ch-b. The CHF updates CDR for this PDU session.

7ch-c. The CHF acknowledges by sending Charging Data Response [Update] to the PGW-C+SMF.

10. If the UE has remaining PDU Sessions in 5GS which it wants to transfer to EPS and maintain the same IP address/prefix, the UE performs the UE requested PDN Connectivity Procedure.

14. The PGW-C+SMF initiates release of the PDU Session(s) in 5GS transferred to EPS.

14ch-a. All counts are closed and a Charging Data Request [Update] is sent to CHF which is triggered by Handover complete charging event.

14ch-b. The CHF updates CDR for this PDU session.

14ch-c. The CHF acknowledges by sending Charging Data Response [Update] to the PGW-C+SMF.

5.2.2.11.7 EPS to 5GS handover for roaming in Home routed scenario

The following figure 5.2.2.11.7.1 describes the handover from EPS to 5GS for roaming in home routed scenario, focusing on the Charging Identifier generation mechanism.

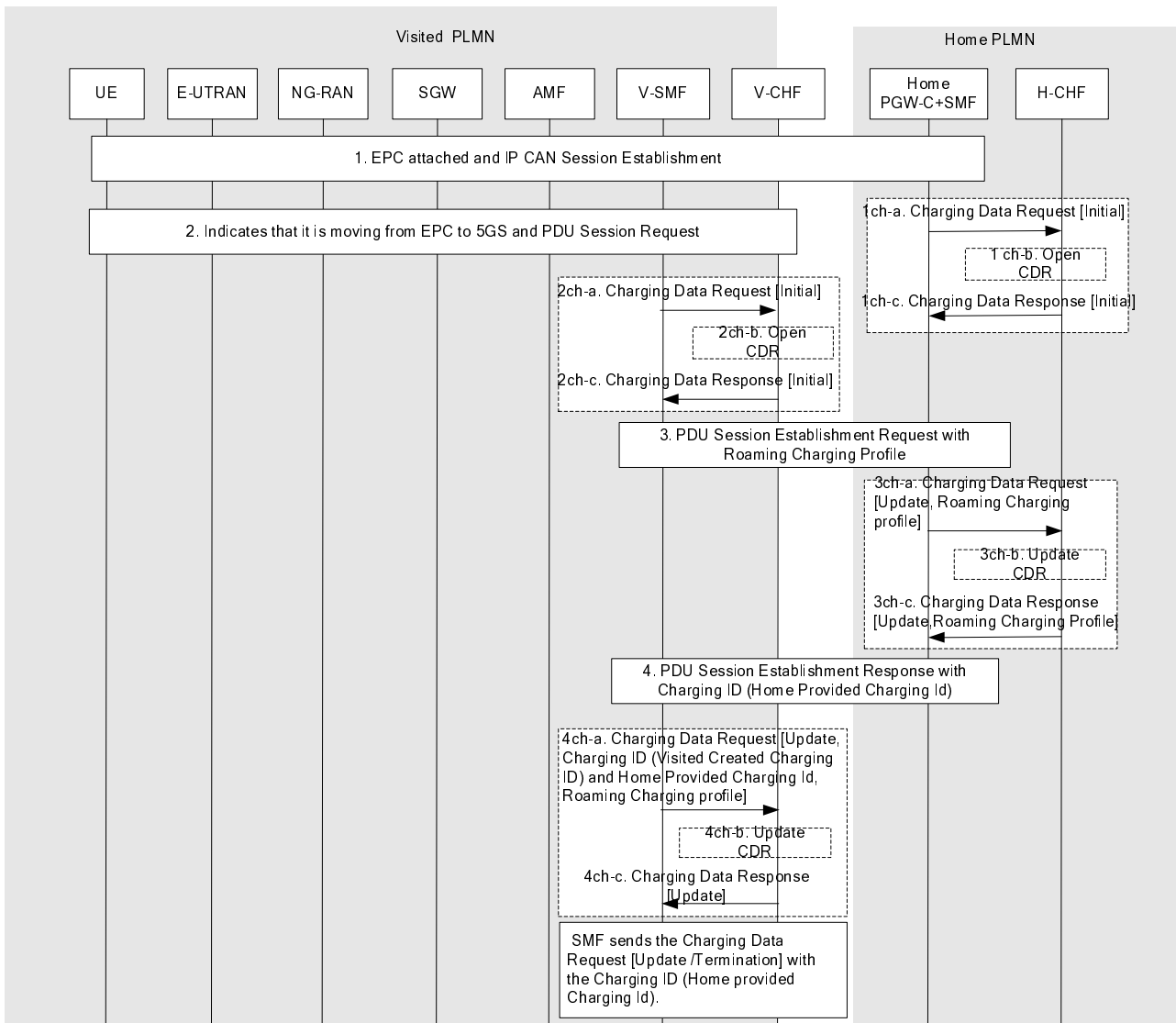

Figure 5.2.2.11.7.1: EPS to 5GS mobility without N26 in Home-Routed Roaming

1. The UE is attached in EPC and initiates a new PDU connection (IP-CAN session).
    - 1ch-a. A Charging Data Request [Initial] is sent to CHF via PGW-C+SMF in HPLMN. The Charging Identifier included is generated by PGW-C +SMF in HPLMN.
    - 1ch-b. The H-CHF opens a CDR
    - 1ch-c. The H-CHF acknowledges by sending Charging Data Response [Initial] to the PGW-C+SMF.
  2. UE initiates registration procedure to the 5GS and indicates that it is moving from EPC. UE requests PDU Session Establishment.
    - 2ch-a. SMF in VPLMN creates a Charging Identifier (visited created Charging Identifier) for the PDU session and sends the Charging Data Request [Initial] to CHF in VPLMN
    - 2ch-b. The CHF in VPLMN opens a CDR.
    - 2ch-c. The CHF in VPLMN acknowledges by sending Charging Data Response [Initial] to the SMF and optionally supplies a “Roaming Charging Profile” to the V-SMF which override the default one.
  3. PDU Session Establishment Request with Roaming Charging Profile
    - 3ch-a. Charging Data Request [Update, Roaming Charging profile]
    - 3ch-b. Update CDR
    - 3ch-c. Charging Data Response [Update, Roaming Charging Profile]
  4. PDU Session Establishment Response with Charging ID (Home Provided Charging Id)
    - 4ch-a. Charging Data Request [Update, Charging ID (Visited Created Charging ID) and Home Provided Charging Id, Roaming Charging profile]
    - 4ch-b. Update CDR
    - 4ch-c. Charging Data Response [Update]
- SMF sends the Charging Data Request [Update /Termination] with the Charging ID (Home provided Charging Id).

3. UPF selection and V-SMF sends the PDU session establishment request to H-SMF.

3ch-a. A Charging Data Request [Update] is sent to CHF in HPLMN, indicating the "Roaming Charging Profile" received from the VPLMN. The same Charging Identifier in step 1ch-a will be the only one Charging Identifier used for any subsequent charging data request sent from H-SMF to CHF i.e. , the Charging Identifier generated in PGW-C +SMF in HPLMN.

3ch-b. The CHF in HPLMN updates the CDR.

3ch-c. The CHF in HPLMN acknowledges by sending Charging Data Response [Update] to the PGW-C+SMF and supplies the HPLMN selected "Roaming Charging Profile" to the PGW-C+SMF.

4. H-SMF sends the PDU session establishment response with Charging Identifier(home provided Charging Identifier).

4ch-a. A Charging Data Request [Update] is sent to CHF in VPLMN, with the "Roaming Charging Profile", Charging Identifier (visited created Charging Identifier) , and home provided Charging Identifier.

4ch-b. The CHF updates the CDR.

4ch-c. The CHF acknowledges by sending Charging Data Response [Update].

In subsequent charging data request sent from V-SMF to V-CHF, the Charging Identifier has the value of home provided Charging Identifier, and the home provided Charging Identifier is not provided.

### 5.2.2.11.8 Handover from EPC/ePDG to 5GS

The following figure 5.2.2.11.11.1 describes the handover from EPC/ePDG to 5GS for non-roaming scenario based on clause 4.11.4.1 Handover from EPC/ePDG to 5GS of TS 23.502 [201].

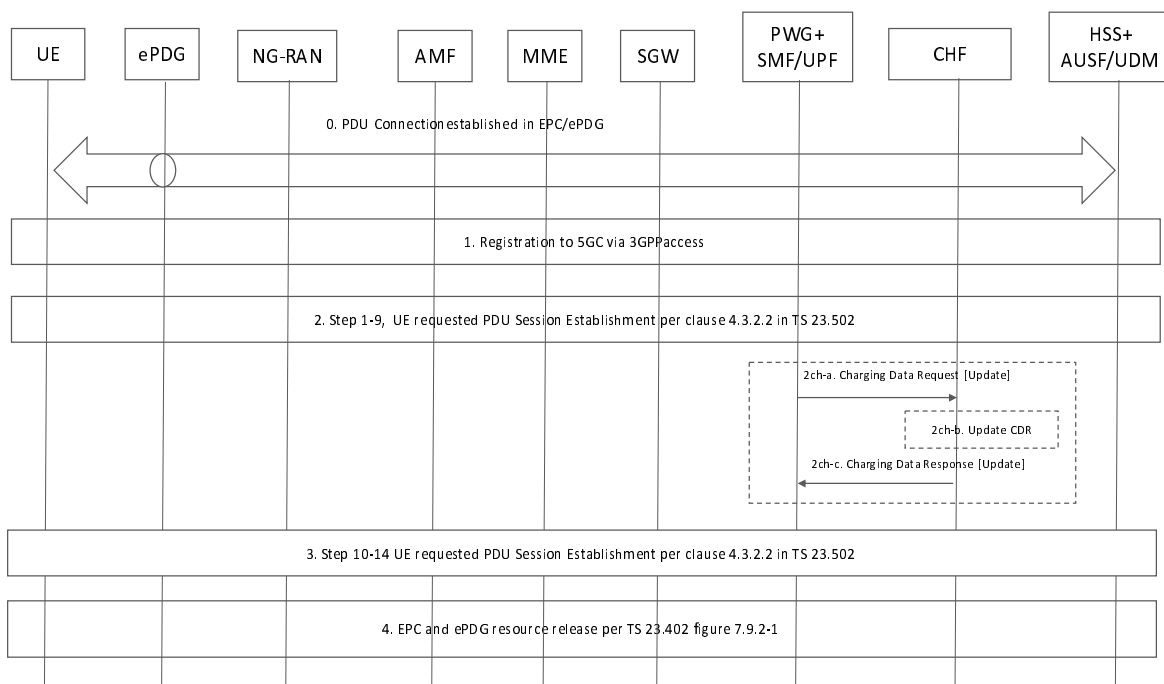

**Figure 5.2.2.11.11.1: Handover from EPC/ePDG to 5GS**

0. One or more PDN Connections have been established.

1. UE register to 5GC via NG RAN.

2. The UE initiates a UE requested PDU Session Establishment via 3GPP Access and includes the "Existing PDU Session" indication or "Existing Emergency PDU Session" and the PDU Session ID.

2ch-a. PGW-C+SMF sends Charging Data Request [Update] to CHF if required by "RAT type change" trigger.

2ch-b. The CHF updates for this PDU session

2ch-c. The CHF acknowledges by sending Charging Data Response [Update] to the PGW-C+SMF.

3. Step 10-14, in procedure of UE requested PDU Session Establishment.

4. The combined PGW+SMF/UPF initiates a PDN GW initiated Resource Allocation Deactivation to release the EPC and ePDG resources.

### 5.2.2.11.9 Handover from 5GS to EPC/ePDG

The following figure 5.2.2.11.9.1 describes the handover from 5GS to EPC/ePDG based on clause 4.11.4.2 Handover from 5GS to EPC/ePDG in TS 23.502 [201].

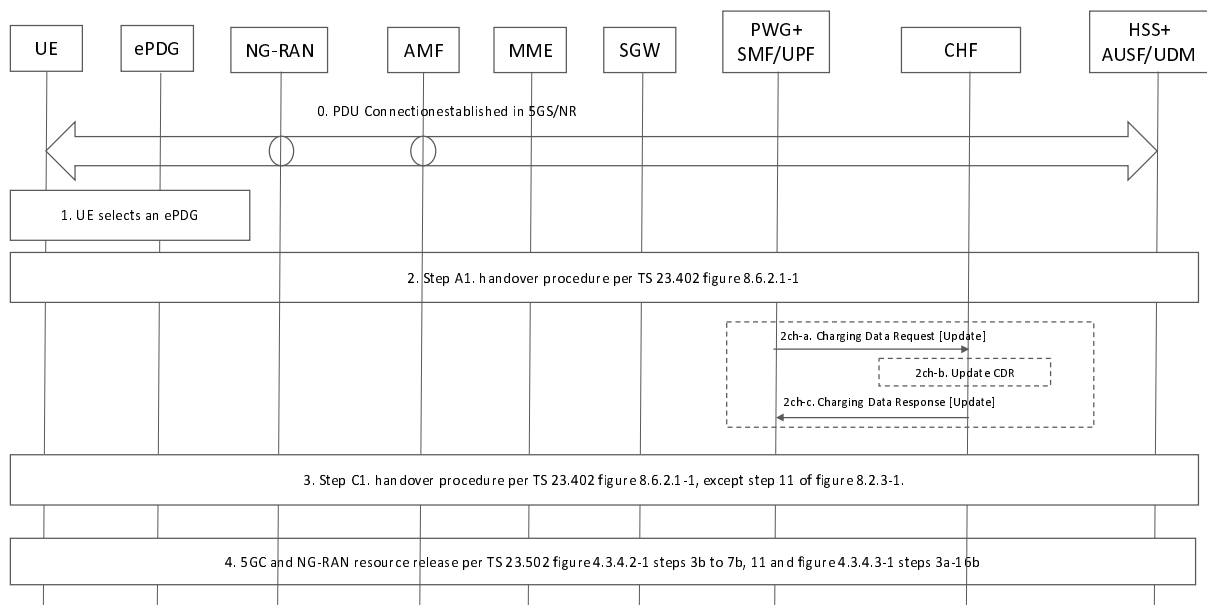

**Figure 5.2.2.11.9.1: Handover from 5GS to EPC/ePDG**

- 0) One or more PDU Sessions have been established between the UE and the SMF/UPF via NG-RAN.
- 1) UE selects an ePDG.
- 2) Step A1 in procedure of the UE initiates a Handover Attach procedure.
  - 2ch-a. PGW-C+SMF sends Charging Data Request [Update] to CHF if required by "RAT type change" trigger.
  - 2ch-b. The CHF updates for this PDU session.
  - 2ch-c. The CHF acknowledges by sending Charging Data Response [Update] to the PGW-C+SMF.
- 3) Step C1, in procedure of the UE initiates a Handover Attach procedure to the release of resources.
- 4) The combined PGW+SMF/UPF initiates a network requested PDU Session Release via 3GPP access.

## 5.2.2.12 PDU session charging for roaming in Home routed scenario

### 5.2.2.12.1 General

The subclauses below describe PDU session charging for roaming in Home routed scenario focusing on roaming QBC procedures between SMF and a CHF in respective PLMNs.

In H-PLMN, PDU session charging for FBC between H-SMF and a H-CHF occurring within the same charging session is not reflected.

### 5.2.2.12.2 PDU session establishment

The following figure 5.2.2.12.2.1 describes a PDU session charging establishment in roaming Home routed scenario based on figure 4.3.2.2.1 TS 23.502 [201] description:

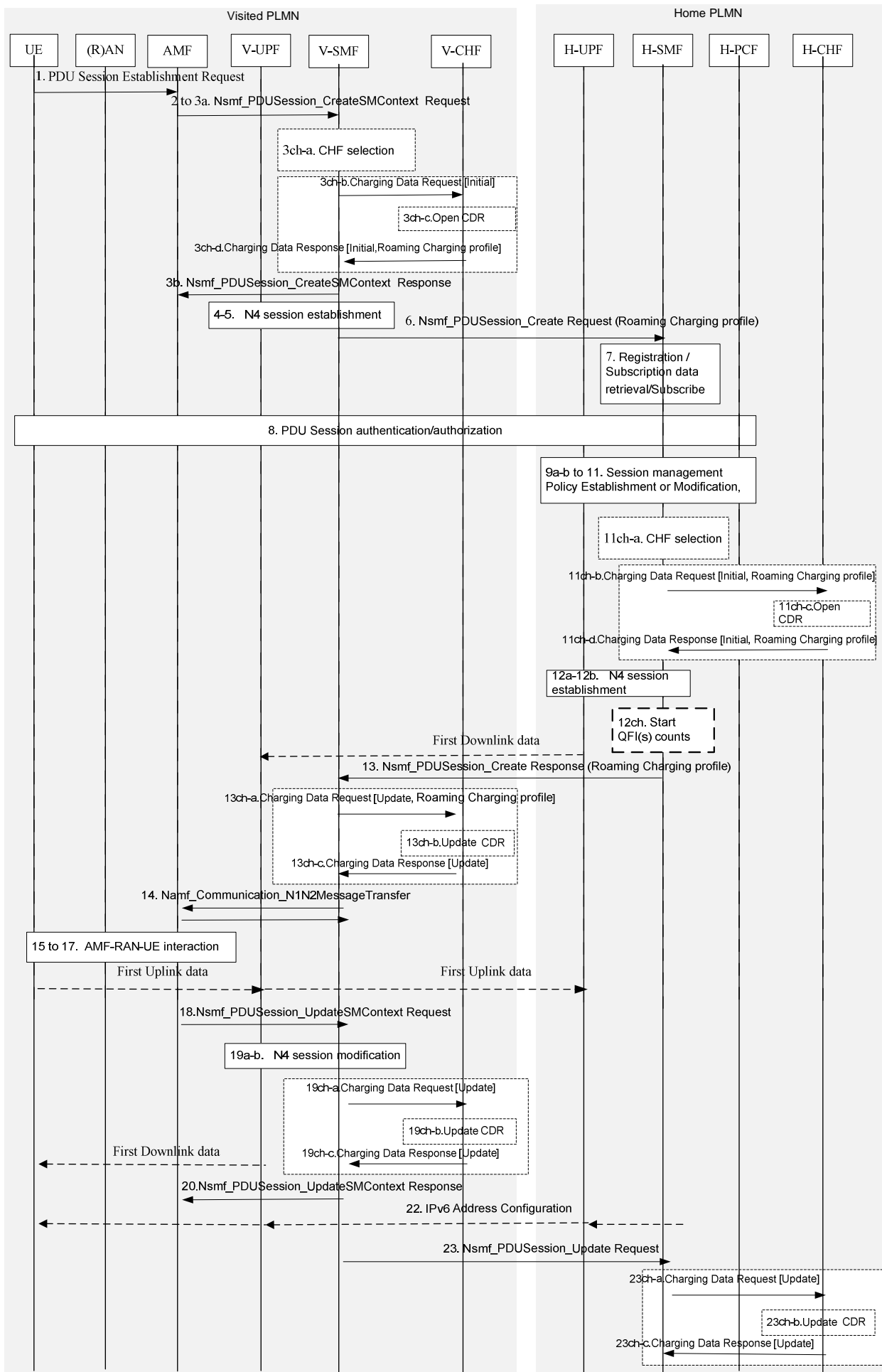

### Figure 5.2.2.12.2.1: PDU session charging: establishment roaming Home Routed

- 1-3a. UE initiates a new PDU session. V-SMF and H-SMF selection by the AMF.
- 3ch-a. The UE is identified as a roamer (PLMN ID of the received SUPI is different from VPLMN PLMN ID), the CHF is selected accordingly (the V-SMF may include 5GS CIoT related information).
- 3ch-b. A Charging Data Request [Initial] is sent to CHF, indicating "in-bound roamer".
- 3ch-c. The CHF opens a CDR (indicating "in-bound roamer")
- 3ch-d. The CHF acknowledges by sending Charging Data Response[Initial] to the SMF and optionally supplies a "Roaming Charging Profile" to the V-SMF which overrides the default one.
10. UPF selection.
11. If dynamic PCC is deployed, SM policy association modification.
- 11ch-a. Based on UE is identified as roaming in a different PLMN, the CHF is selected accordingly.
- 11ch-b. A Charging Data Request [Initial] is sent to CHF, indicating "out-bound roamer", with the "Roaming Charging Profile" received from the VPLMN (the H-SMF may include 5GS CIoT related information).
- 11ch-c. The CHF opens a CDR (indicating "out-bound roamer").
- 11ch-d. The CHF acknowledges by sending Charging Data Response[Initial] to the H-SMF and supplies the HPLMN selected "Roaming Charging Profile" (either the same as the one received from VPLMN, either its own selected) to the H-SMF.
- [12a-b]. The SMF initiates an N4 Session Establishment procedure with the selected UPF.
- 12ch. Counts per QFI are started.
13. Nsmf\_PDUSession\_Create Response from H-SMF to V-SMF
- 13ch-a. Based on "received PDU session conditions" trigger, a Charging Data Request [Update] is sent to CHF with charging information received from H-SMF, which includes the HPLMN selected "Roaming Charging Profile" and counts per QFI are started.
- 13ch-b. The CHF updates the CDR.
- 13ch-c. The CHF acknowledges by sending Charging Data Response[Update] to the V-SMF.
- 19a-b. N4 session modification.
- 19ch-a. Counts per rejected QFI(s) are closed. A Charging Data Request [Update] is sent to CHF to report if needed.
- 19ch-b. The CHF updates the CDR.
- 19ch-c. The CHF acknowledges by sending Charging Data Response[Update] to the V-SMF.
23. Nsmf\_PDUSession\_UpdateRequest from V-SMF to H-SMF. The rejected QFI(s) are notified to H-SMF.
- 23ch-a. Counts per rejected QFI(s) are closed. A Charging Data Request [Update] is sent to CHF to report if needed.
- 23ch-b. The CHF updates the CDR.
- 23ch-c. The CHF acknowledges by sending Charging Data Response[Update] to the H-SMF.

### 5.2.2.12.3 PDU session modification

The following figure 5.2.2.12.3.1 describes a PDU Session Modification procedure, home-routed roaming scenario based on figure 4.3.3.3.1 TS 23.502 [201] description:

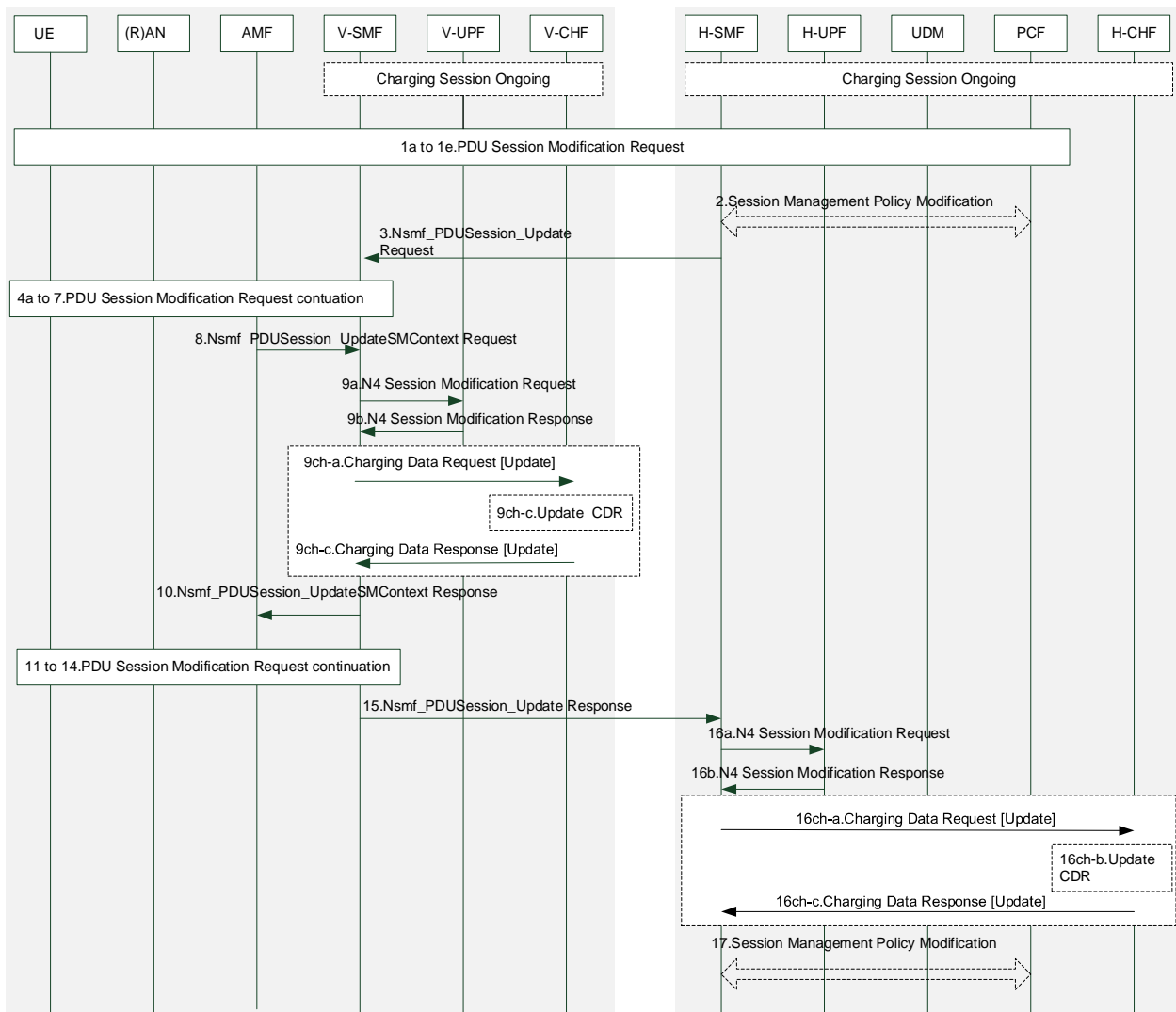

**Figure 5.2.2.12.3.1: UE or network requested PDU Session Modification (for home-routed roaming scenario)**

9ch-a. A Charging Data Request [Update] is sent to V-CHF with charging information received from V-SMF, if needed and new counts per QFI are started.

9ch-b. The CHF updates the CDR.

9ch-c. The CHF acknowledges by sending Charging Data Response[Update] to the V-SMF.

16ch-a. A Charging Data Request [Update] is sent to H-CHF with charging information received from H-SMF, if needed, and new counts per QFI are started.

16ch-b. The CHF updates the CDR.

16ch-c. The CHF acknowledges by sending Charging Data Response[Update] to the H-SMF.

#### 5.2.2.12.4 PDU session release

The following figure 5.2.2.8.4.1 describes a PDU session charging release in roaming home routed scenario based on figure 4.3.4.3.1 TS 23.502 [201] description:



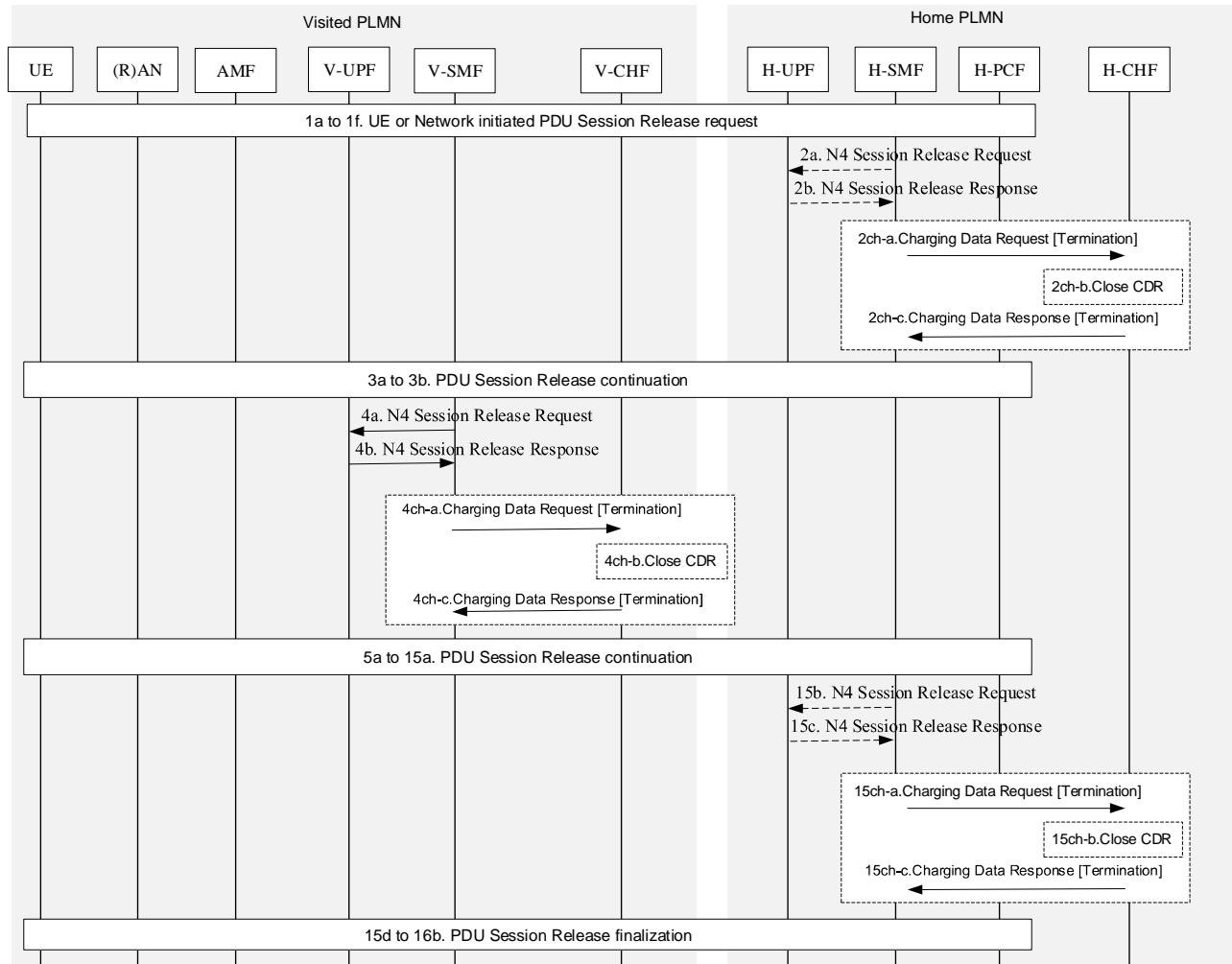

**Figure 5.2.2.12.4.1: PDU session charging: release roaming home Routed**

2a-2b. (UE, (R)AN or serving network initiated) N4 session release between H-SMF and H-UPF.

2ch\_a. A Charging Data Request [Termination] is sent to CHF with the set of QFI(s) counts.

2ch-b. The CHF closes the CDR

2ch-c. The CHF acknowledges by sending Charging Data Response[Termination] to the H-SMF.

4a-4b. N4 session release between V-SMF and V-UPF.

4ch-a. A Charging Data Request [Termination] is sent to CHF with the set of QFI(s) counts.

4ch-b. The CHF closes the CDR

4ch-c. The CHF acknowledges by sending Charging Data Response[Termination] to the V-SMF.

15b-15c. (HPLMN initiated release) N4 session release between H-SMF and H-UPF.

15ch\_a. A Charging Data Request [Termination] is sent to CHF with the set of QFI(s) counts.

15ch-b. The CHF closes the CDR

15ch-c. The CHF acknowledges by sending Charging Data Response [Termination] to the H-SMF.

NOTE: Either 2ch or 15ch is done depending on if the release is UE, (R)AN, serving network, or HPLMN initiated.

### 5.2.2.13 PDU session charging - non-3GPP access

#### 5.2.2.13.1 General

After UE registration to 5GC via an non-3GPP access network, a PDU session can be established via this non-3GPP access. For following scenarios, the PDU session establishment via untrusted non-3GPP access network is specified in clause 4.12 of TS 23.502 [201] and the PDU session establishment via trusted non-3GPP access network is specified in clause 4.12a of TS 23.502 [201]:

- UE initiated PDU session establishment;
- Handover of a PDU Session from 3GPP access to untrusted non-3GPP access;
- Service Request procedures via Untrusted non-3GPP Access specified in clause 4.12.4.5 of TS 23.502 [201];
- Service Request procedures via Trusted non-3GPP Access specified in clause 4.12.4a.5 of TS 23.502 [201].

Handover procedure of a PDU Session between 3GPP access and non-3GPP access is achieved by PDU Session Establishment over source access followed by PDU Session Release over the target access for respective N2 Resources Release. The PDU Session ID, IP address/prefix, and SSC mode are maintained during the move.

PDU session over Untrusted non-3GPP Access release and Trusted non-3GPP Access release are specified in clause 4.12.7 and clause 4.12a.7 of TS 23.502 [201].

#### 5.2.2.13.2 PDU session establishment

##### 5.2.2.13.2.1 PDU session establishment via an untrusted non-3GPP access network

The following figure 5.2.2.13.2.1 describes a PDU session charging establishment via an untrusted non-3GPP access network scenario based on figure 4.12. 5.1 in TS 23.502 [201] description:

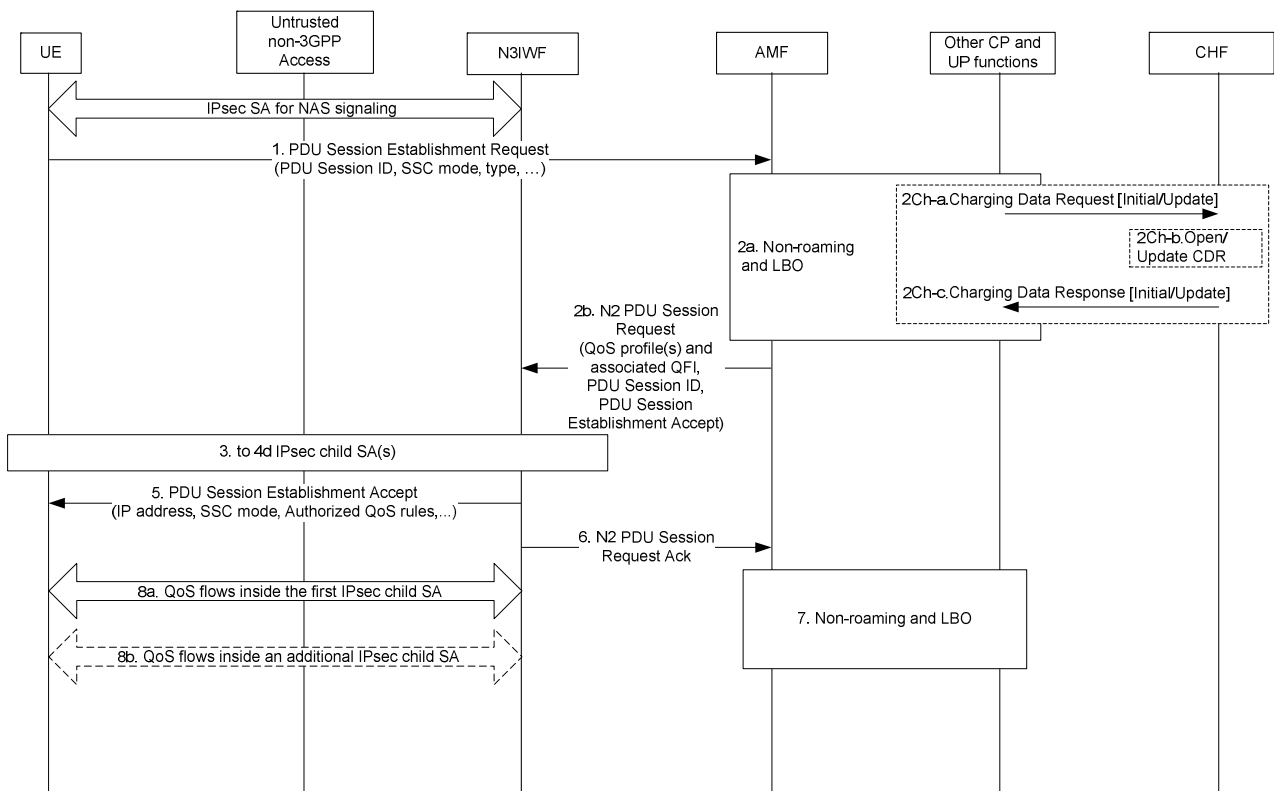

**Figure 5.2.2.13.2.1: PDU Session establishment via untrusted non-3GPP access**

[2ch-a to 2ch-c]. Two cases:

- In case of "Initial request" the same steps as steps 7ch-a to 7ch-c in figure 5.2.2.2.1 apply, for initial SMF interaction with CHF, with Charging Data Request [Initial].
- In case of "Existing PDU Session" the "radio access type change" trigger may apply for SMF interaction with CHF, with Charging Data Request [Update].

**5.2.2.13.2.2 PDU session establishment via Trusted Non-3GPP access network**

After the UE registers to 5GC via trusted non-3GPP access network, the UE may request a PDU Session establishment by using the same procedure as the one specified in clause 5.2.2.13.2.1 for untrusted non-3GPP access, with the following modifications:

- The N3IWF in Figure 5.2.2.13.2.1 should be substituted with a TNGF and the Untrusted non-3GPP access should be substituted with a Trusted non-3GPP Access Point (TNAP).
- Charging Data Request [Initial/Update] contains RAT type and user location specifics to trusted non-3GPP.
- The TNGF may send a TNGF Identities parameter to AMF inside an N2 Uplink NAS Transport message. The TNGF Identities parameter contains a list of identifiers (i.e. FQDNs or IP addresses) of N3 terminations supported by the TNGF. If received by the AMF, it shall forward it to the SMF, which may use it as input to UPF selection.

**5.2.2.13.3 PDU session modification**

**5.2.2.13.3.1 PDU session modification via an untrusted non-3GPP access network**

The following figure 5.2.2.13.3.1 describes a PDU session charging modification via an untrusted non-3GPP access network scenario based on figure 4.12.16.1 in TS 23.502 [201] description:

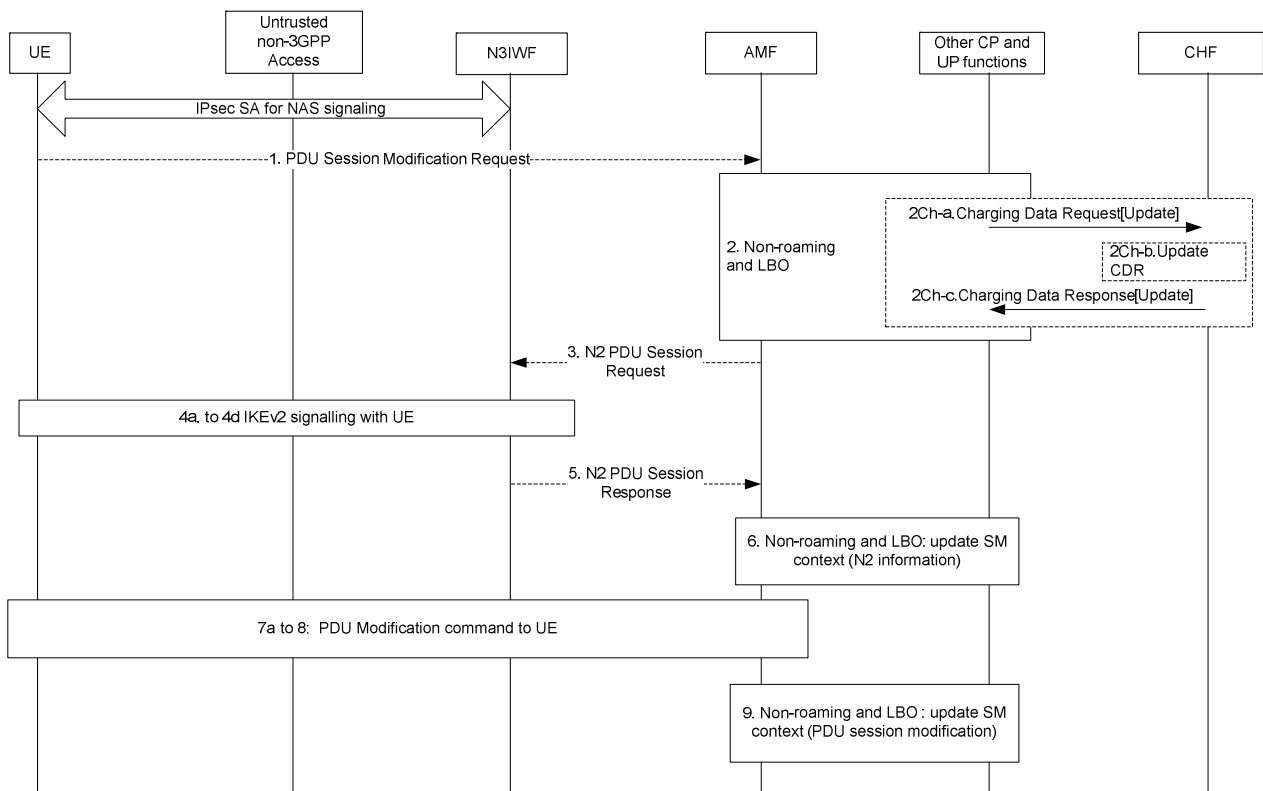

**Figure 5.2.2.13.3.1: PDU Session modification via untrusted non-3GPP access**

[2ch-a to 2ch-c]: Interaction between SMF and CHF triggered by the modification applied to the PDU session (e.g. QoS handling).

**5.2.2.13.3.2 PDU session modification via Trusted Non-3GPP access network**

The UE or network requested PDU Session Modification procedure via trusted non-3GPP access network is the same procedure as the one specified in clause 5.2.2.13.3.1 for untrusted non-3GPP access, with the following modifications:

- The N3IWF in Figure 5.2.2.13.3.1 should be substituted with a TNGF and the Untrusted non-3GPP access should be substituted with a Trusted non-3GPP Access Point (TNAP).
- Interaction between SMF and CHF triggered by the modification contains RAT type and user location specifics to trusted non-3GPP.

**5.2.2.13.4 PDU session release**

**5.2.2.13.4.1 PDU session release via an untrusted non-3GPP access network**

The following figure 5.2.2.13.4.1 describes a PDU session charging release via an untrusted non-3GPP access network scenario based on figure 4.12.17.1 in TS 23.502 [201] description:

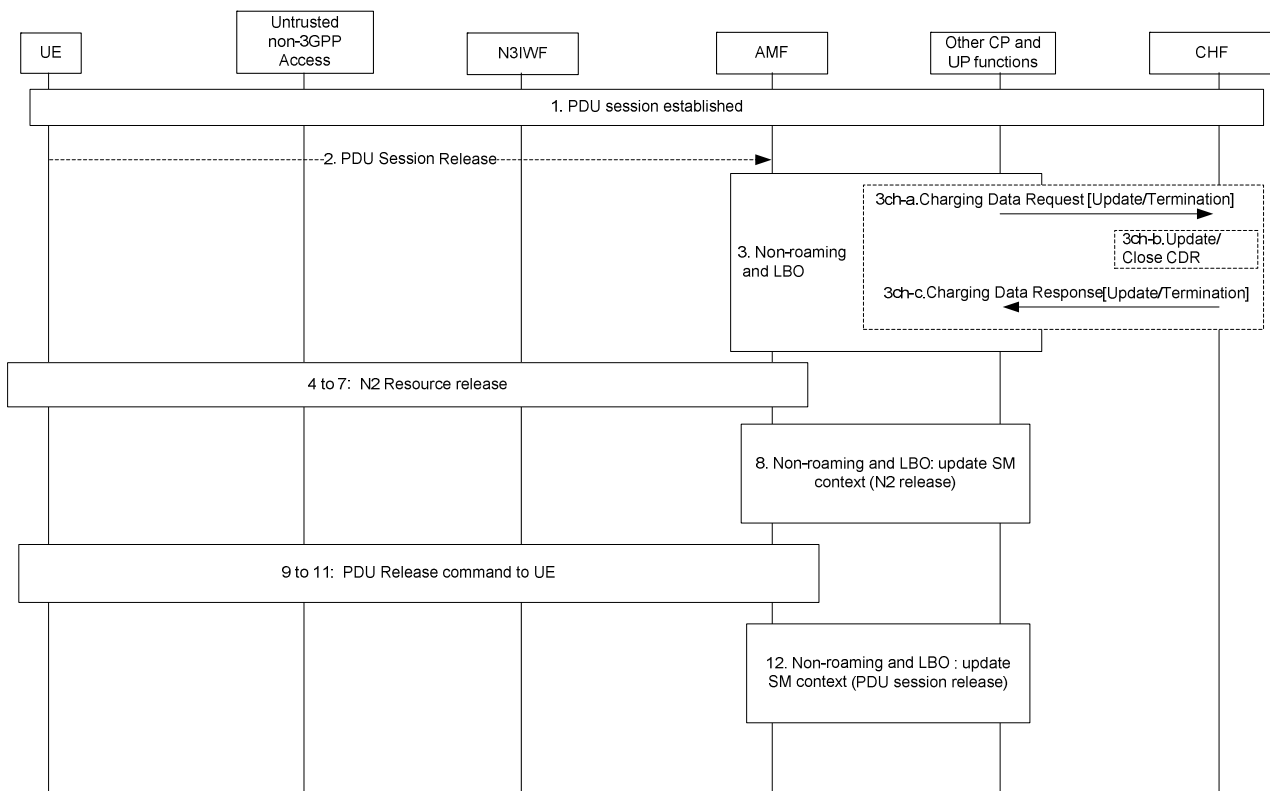

**Figure 5.2.2.13.4.1: PDU Session release via untrusted non-3GPP access**

[3cha-3chb]. Two cases:

- In case the PDU session needs to be released, SMF interaction with CHF for release, with Charging Data Request [Termination].
- In case of handover from non-3GPP access to 3GPP access, SMF may interact with CHF, with Charging Data Request [Update].

NOTE 1: the "radio access type change" trigger, if enabled, applied during the PDU session establishment over the 3GPP access which was performed prior to this PDU session release over non-3GPP access.

**5.2.2.13.4.2 PDU session release via Trusted Non-3GPP access network**

The UE or the network can release a PDU Session via a trusted non-3GPP access network as specified in clause 5.2.2.13.4.1 for the untrusted non-3GPP access with the following modifications:

- The untrusted non-3GPP access is substituted by a trusted non-3GPP access point (TNAP).
- The N3IWF is substituted by the TNGF.

**5.2.2.14 PDU session served by I-SMF and SMF**

**5.2.2.14.1 General**

When the I-SMF is inserted, re-allocated, or removed in a PDU Session as specified in TS 23.501 [200], the SMF may report the charging information to the CHF.

When the I-SMF with UL CL/BP is inserted based on information received from SMF, the I-SMF forwards traffic usage information to the SMF as specified in TS 23.501 [200].

When the V-SMF is changed for a Home Routed PDU Session as specified in TS 23.502 [201], the H-SMF may report the charging information to the H-CHF.

#### 5.2.2.14.2 PDU session establishment with I-SMF insertion

The following figure 5.2.2.14.2.1 describes a PDU session establishment charging, for the case where the service area of the selected SMF does not include the location where the UE camps, based on TS 23.502 [201] figure 4.3.2.2.2, where the V-SMF and V-UPF are replaced by I-SMF and I-UPF, and H-SMF and H-UPF are replaced by SMF and UPF (PSA) respectively:

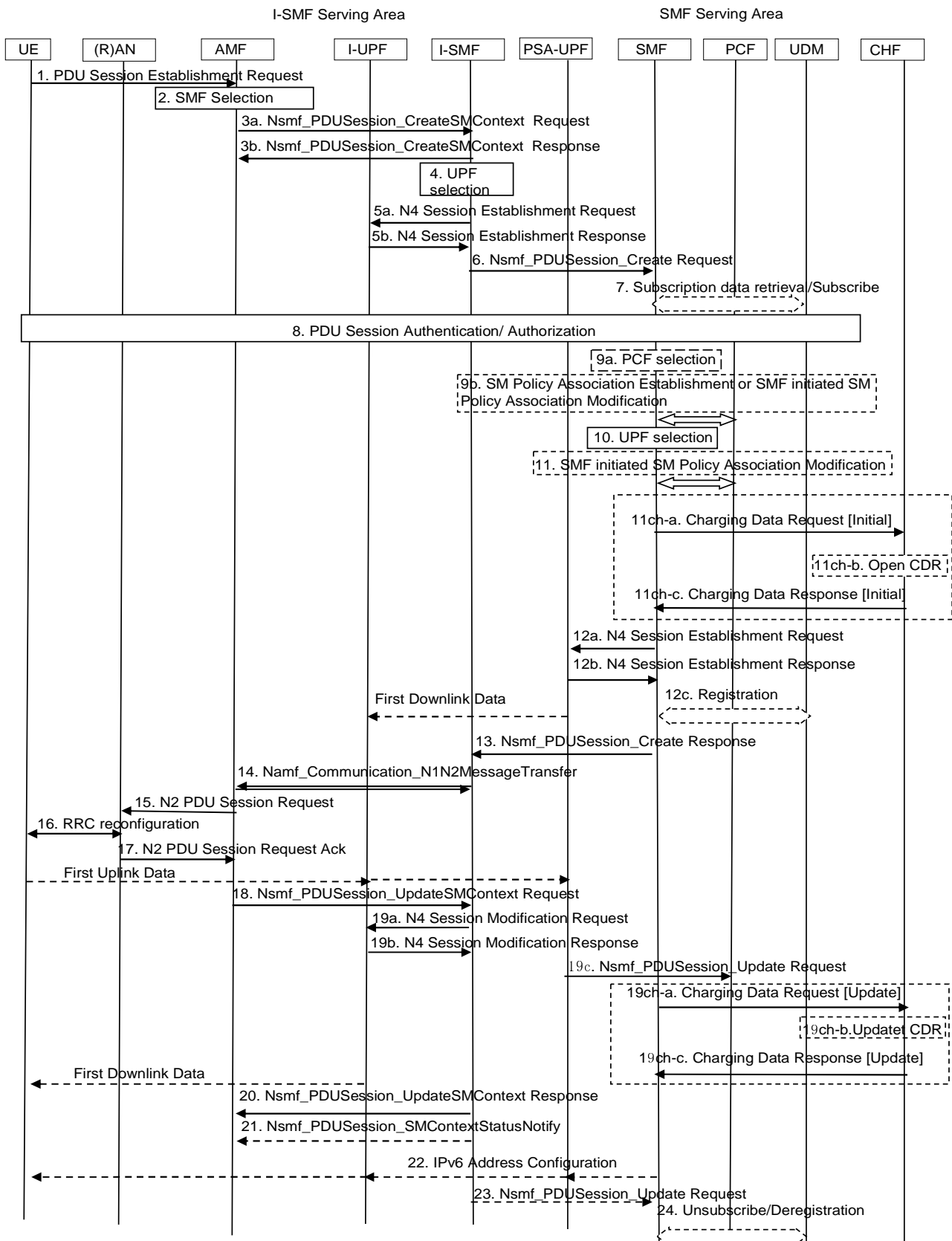

Figure 5.2.2.14.2.1: UE-requested PDU Session Establishment with I-SMF insertion

2. The AMF selects SMF and I-SMF upon SMF serving area cannot cover UE location.

5a. I-SMF selects one or more UPFs.

11. The SMF may perform a Session Management Policy Modification procedure to report some event to the PCF that has previously subscribed.
- 11ch-a. The SMF creates a Charging Identifier for the PDU session and sends Charging Data Request [Initial] including I-SMF information to CHF for authorization for the subscriber to start the PDU session which is triggered by start of PDU session charging event.
- 11ch-b. The CHF opens CDR for this PDU session.
- 11ch-c. The CHF acknowledges by sending Charging Data Response [Initial] to the SMF.
14. AMF to SMF: SM Request (N2 SM information).
- [19a-b]. N4 session Modification.
- 19c, I-SMF notify SMF on N4 information with Traffic usage reporting.
- 19ch-a. This step may occur in case "start of service data flow" needs quota from CHF, for the SMF to request quota for both own and I-SMF usage.
- 19ch-b. The CHF updates CDR for this PDU session.
- 19ch-c. The CHF acknowledges by sending Charging Data Response [Update] to the SMF.
- NOTE 1: The steps from 19ch-a to 19ch-c for quota request from CHF are not applicable for offline only charging.
20. SM Request with PDU session Update Response to AMF.
21. SMF sends SM Context Status Notify to AMF.
22. In case of PDU Type IPv6, IPv6 Address Configuration.
- NOTE 2: I-SMF controlling both I-UPF and PSA2 UPF upon local traffic offload scenarios, can enforce usage report and/or quota management for PSA2 UPF.

#### 5.2.2.14.3 PDU Session modification procedure with I-SMF involved

The following figure 5.2.2.14.3-1 describes a PDU Session modification charging message flow, for the case where the service area of the selected SMF does not include the location where the UE camps, with simplified I-SMF with UE and Serving Network message flows, based on TS 23.502 [201] figure 4.3.3.3-1, where the V-SMF and V-UPF are replaced by I-SMF and I-UPF, and H-SMF and H-UPF are replaced by SMF and UPF (PSA) respectively:



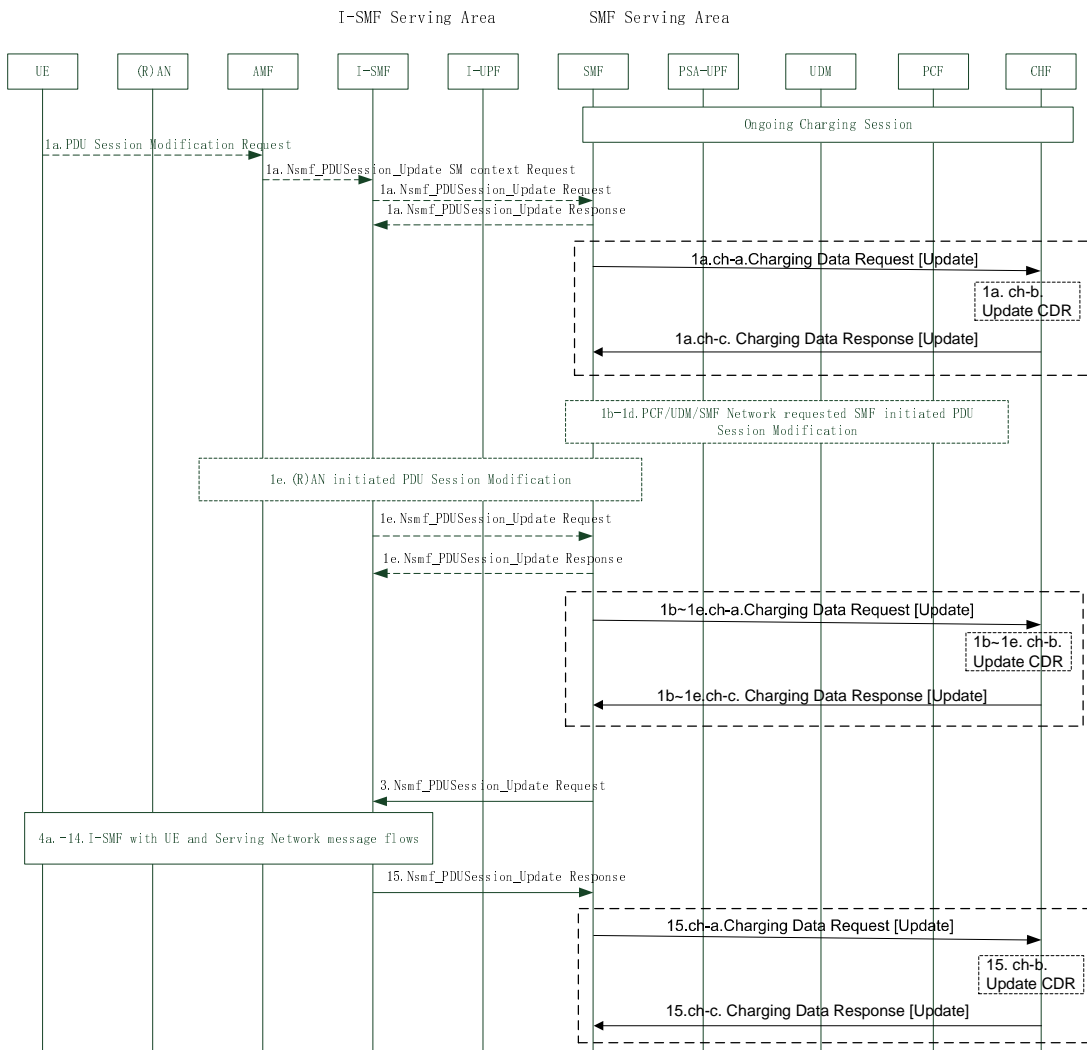

**Figure 5.2.2.14.3-1: UE or network requested PDU Session Modification charging with I-SMF involved**

PDU Session served by both I-SMF and SMF has been established, with the ongoing Charging session.

1a. UE or serving network AMF requested PDU Session Modification Request to I-SMF, I-SMF invokes a Nsmf\_PDUSession\_Update Request message to SMF, including User Location Information, QoS information and I-SMF information. SMF accept with Nsmf\_PDUSession\_Update\_Response message to I-SMF.

1a.ch-a. All counts are closed in SMF and a Charging Data Request [Update] message with PDU Session related triggers including I-SMF information is sent to CHF, if required by immediate report category trigger. New counts and time stamps for all active service data flows are started in the SMF.

1a.ch-b. The CHF updates CDR for this PDU session.

1a.ch-c. The CHF acknowledges by sending Charging Data Response [Update] message to the SMF.

1b~1d. With PCF initiated SM Policy Association Modification or UDM updated the subscription data or SMF decided to modify PDU Session triggers, SMF starts SMF requested PDU Session Modification procedures.

1e. (R)AN initiated PDU Session Modification Request to I-SMF, I-SMF invokes a Nsmf\_PDUSession\_Update Request message to SMF, including User Location Information, QoS information with indication of QoS flow released and I-SMF information. SMF accept with Nsmf\_PDUSession\_Update\_Response message to I-SMF.

1b~1e.ch-a. All counts are closed in SMF and a Charging Data Request [Update] message with PDU Session related triggers including I-SMF information is sent to CHF, if required by immediate report category trigger. New counts and time stamps for all active service data flows are started in the SMF.

1b~1e.ch-b. The CHF updates CDR for this PDU session.

- 1b~1e.ch-c. The CHF acknowledges by sending Charging Data Response [Update] message to the SMF.
- 3. With SMF initiated QoS flows modification procedure, SMF invokes a Nsmf\_PDUSession\_Update Request message to I-SMF.
- 4~14. I-SMF interacting with UE and Serving Network message flows, including the QoS rule(s) and QoS Flow level QoS parameters operations.
- 15. I-SMF invokes a Nsmf\_PDUSession\_Update Response message to SMF, including User Location Information, QoS flow information and I-SMF information.
- 15.ch-a. All counts are closed in SMF and a Charging Data Request [Update] message with PDU Session related triggers including I-SMF information is sent to CHF, if required by immediate report category trigger. New counts and time stamps for all active service data flows are started in the SMF.
- 15.ch-b. The CHF updates CDR for this PDU session.
- 15.ch-c. The CHF acknowledges by sending Charging Data Response [Update] message to the SMF.

**5.2.2.14.4 PDU Session release procedure with I-SMF involved**

The following figure 5.2.2.14.4-1 describes a PDU session release charging message flow, for the case where the service area of the selected SMF does not include the location where the UE camps, with simplified I-SMF with UE and Serving Network message flows , based on TS 23.502 [201] figure 4.3.4.3-1, where the V-SMF and V-UPF are replaced by I-SMF and I-UPF, and H-SMF and H-UPF are replaced by SMF and UPF (PSA) respectively.

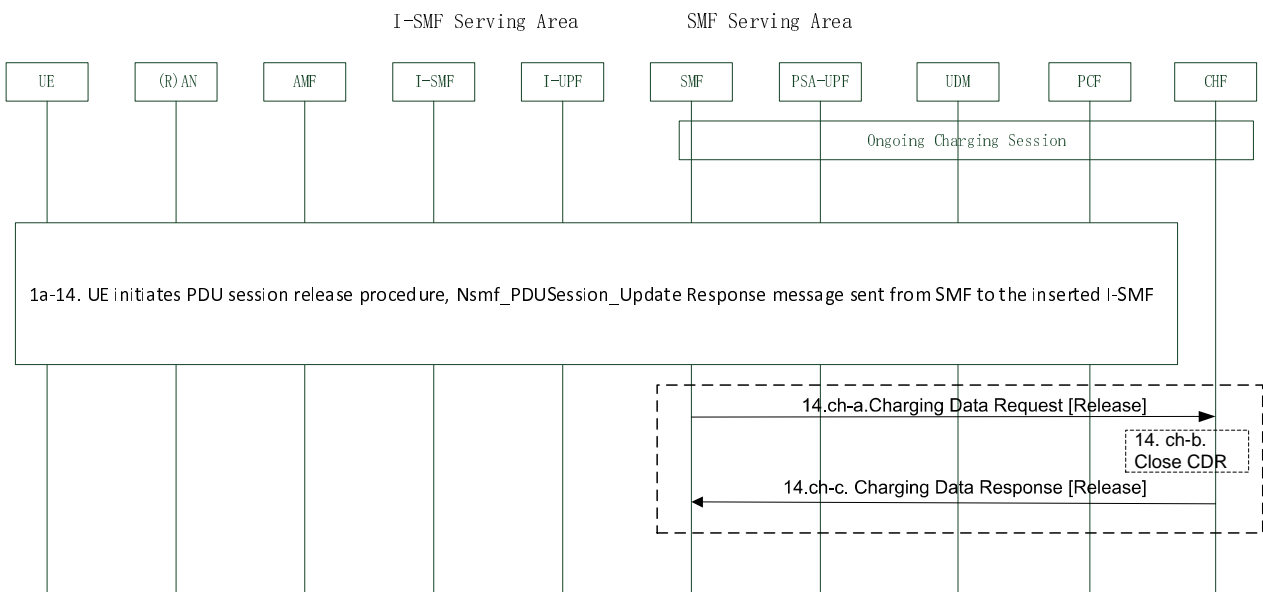

**Figure 5.2.2.14.4-1: UE or network requested PDU Session release charging with I-SMF involved**

PDU Session served by both I-SMF and SMF has been established, with the ongoing Charging session.

- 1a-14. UE initiates PDU session release procedure, finally with Nsmf\_PDUSession\_Update Response message sent from SMF to the inserted I-SMF.
- 14.ch-a. All counts are closed in SMF and a Charging Data Request [Release] message including I-SMF information is sent to CHF, with usage reporting.
- 14.ch-b. The CHF close CDR for this PDU session.
- 14.ch-c. The CHF acknowledges by sending Charging Data Response [Release] message to the SMF.

### 5.2.2.14.5 PDU Session procedures with I-SMF insertion/change/removal

PDU Session procedures with I-SMF insertion/change/removal, including below three figures described procedures covering Service Request, N2 based handover and Xn based handover.

The following figure 5.2.2.14.5-1 describes PDU session charging message flows, for the Service Request cases where

- the UE moves from SMF service area to new I-SMF service area, a new I-SMF is inserted (i.e. I-SMF insertion); or
- the UE moves from old I-SMF service area to new I-SMF service area, the I-SMF is changed (i.e. I-SMF change); or
- the UE moves from I-SMF service area back to SMF service area, the I-SMF is removed (i.e. I-SMF removal).

with simplified UE with 5GS message flows, based on TS 23.502 [201] figure 4.23.4.3-1, for I-SMF insertion, change, removal respectively, and specifies the corresponding charging message flow between SMF and CHF.

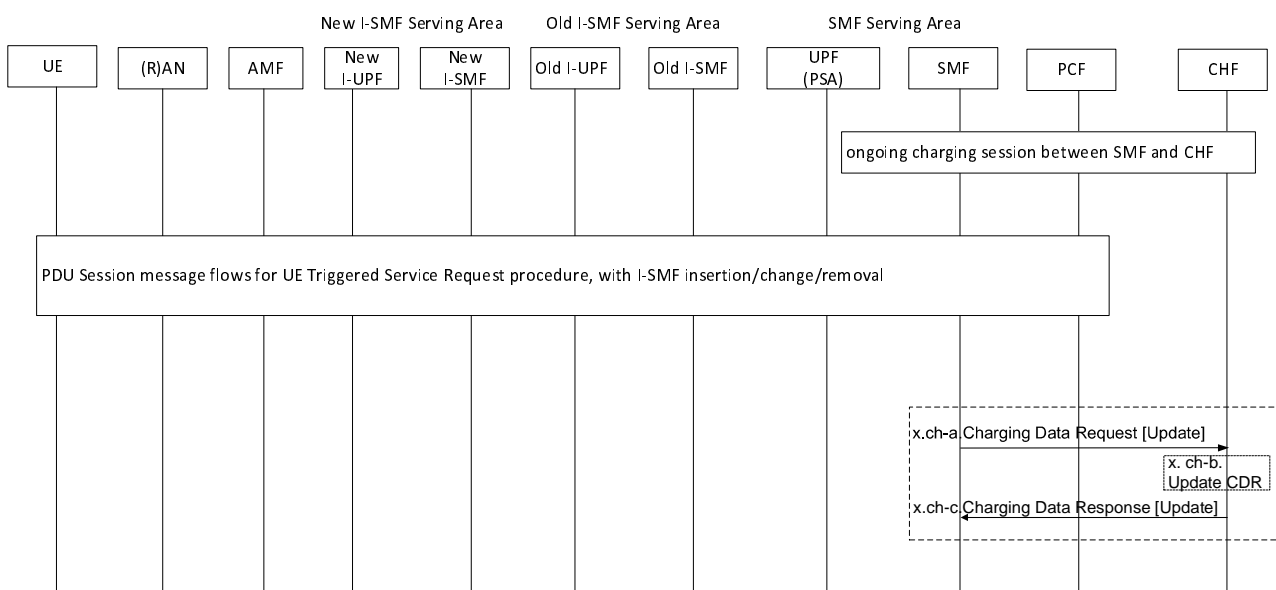

**Figure 5.2.2.14.5-1: PDU Session charging message flows for UE Triggered Service Request procedure with I-SMF insertion/change/removal**

PDU Session served by both I-SMF and SMF has been established, with the ongoing Charging session.

PDU Session message flows for UE Triggered Service Request procedure, with I-SMF insertion/change/removal triggers charging message flows as below:

- I-SMF insertion message flows, upon UE moves from SMF service area to I-SMF service area, finally with Nsmf\_PDUSession\_Create Response message sent from SMF to the inserted I-SMF (Detail message flows refer to TS 23.502,4.23.4.3-1 step 3 to 8c), or finally with Nsmf\_PDUSession\_Update Response message sent from SMF to the inserted I-SMF (Detail message flows refer to TS 23.502 [201],4.23.4.3-1 step 18 to 20c).
- I-SMF change message flows, upon UE moves from old SMF service area to new I-SMF service area, finally with Nsmf\_PDUSession\_Update Response message sent from SMF to the inserted new I-SMF (Detail message flows refer to TS 23.502 [201],4.23.4.3-1 step 3 to 8c, or step 18 to 20c).
- I-SMF removal message flows, upon UE moves from I-SMF service area back to SMF service area, finally SMF send Nsmf\_PDUSession\_CreateSMContext Response message to AMF (Detail message flows refer to TS 23.502,4.23.4.3-1 step 10 to 16), or SMF send Nsmf\_PDUSession\_UpdateSMContext Response message to AMF (Detail message flows refer to TS 23.502 [201], 4.23.4.3-1 step 22 to 25)

x.ch-a. All counts are closed in SMF, and a Charging Data Request [Update] message including I-SMF information and “insertion/change/removal of I-SMF” trigger is sent to CHF, if required by immediate report category trigger. New counts and time stamps for all active service data flows are started in the SMF.

x.ch-b. The CHF updates CDR for this PDU session.

x.ch-c. The CHF acknowledges by sending Charging Data Response [Update] message to the SMF.

NOTE 1: x in figure 5.2.2.14.5-1, refer to the last step number in the detail message flows. For I-SMF insertion or I-SMF change, x refers to 8c or 20c. For I-SMF removal, x refers to 16 or 25.

The following figure 5.2.2.14.5-2 describes PDU session charging message flows, for N2 based handover, with I-SMF insertion, change, removal.

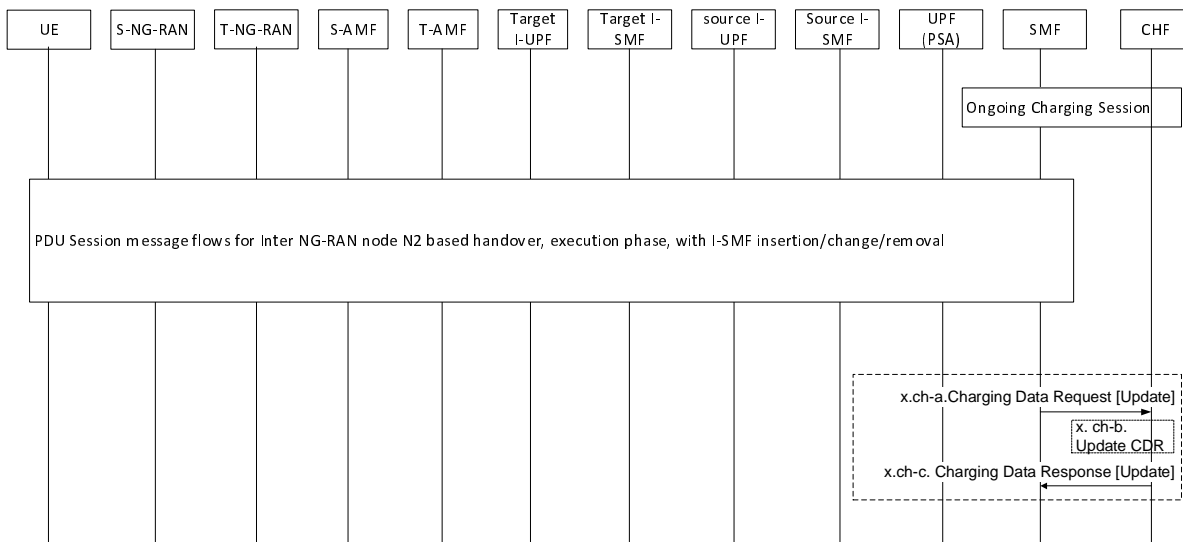

**Figure 5.2.2.14.5-2: PDU Session charging message flows for Inter NG-RAN node N2 based handover, execution phase, with I-SMF insertion/change/removal**

PDU Session served by both I-SMF and SMF has been established, with the ongoing Charging session between SMF and CHF.

PDU Session message flows for Inter NG-RAN node N2 based handover procedure, with I-SMF insertion/change/removal triggers charging message flows as below:

- I-SMF insertion message flows, for N2 based handover, refer to TS 23.502 [201], 4.23.7.3.3-1 step 2 to 8.
- I-SMF Change message flows, for N2 based handover, refer to TS 23.502 [201], 4.23.7.3.3-1 step 2 to 8,
- I-SMF Removal message flows, for N2 based handover, refer to TS 23.502 [201], 4.23.7.3.3-1 step 10 to 14.

x.ch-a. All counts are closed in SMF with the I-SMF, and a Charging Data Request [Update] message including I-SMF information and “insertion/change/removal of I-SMF” trigger is sent to CHF, if required by immediate report category trigger. New counts and time stamps for all active service data flows are started in the SMF.

x.ch-b. The CHF updates CDR for this PDU session.

x.ch-c. The CHF acknowledges by sending Charging Data Response [Update] message to the SMF.

NOTE 2: x in figure 5.2.2.14.5-2, refer to the last step number in the detail message flows. For I-SMF insertion or I-SMF change, x refers to 8. For I-SMF removal, x refers to 14.

The following figure 5.2.2.14.5-3 describes PDU session charging message flows, for Xn based handover, with I-SMF insertion, change, removal.

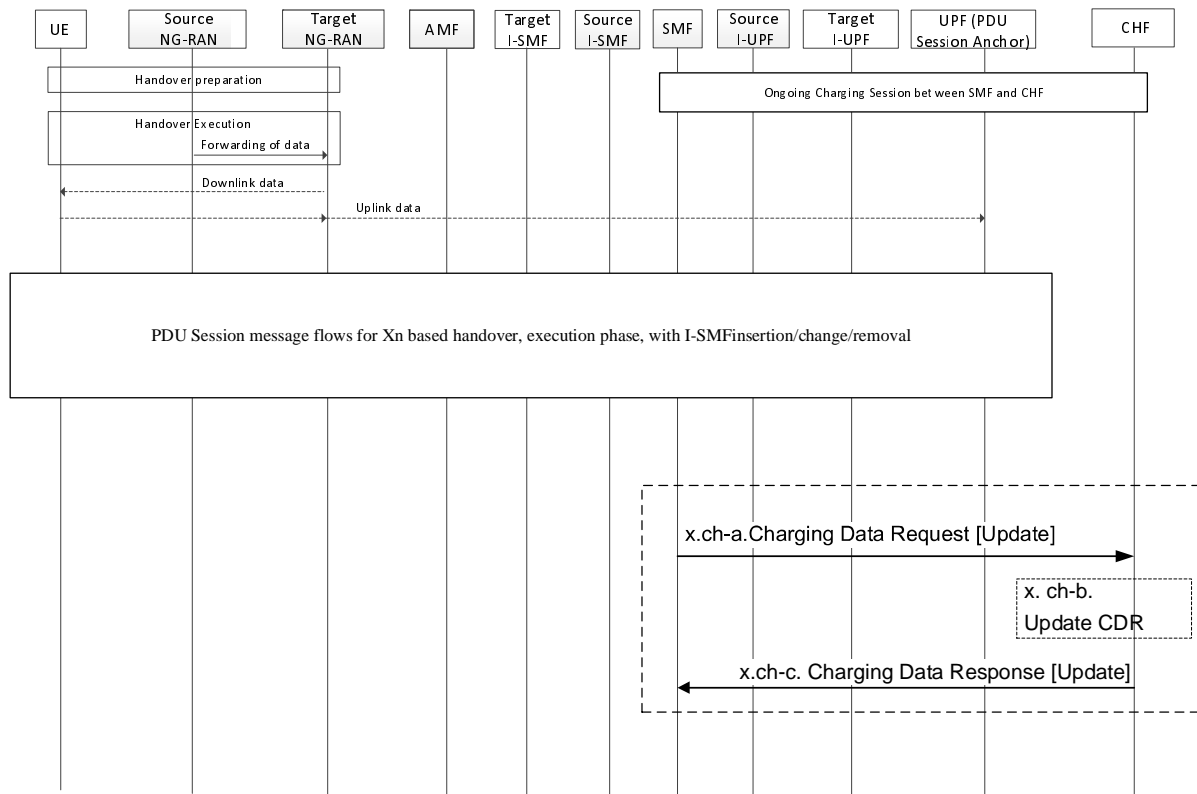

**Figure 5.2.2.14.5-3: PDU Session charging message flows for Xn based handover, execution phase, with I-SMF insertion/change/removal**

PDU Session served by both I-SMF and SMF has been established, with the ongoing Charging session between SMF and CHF.

PDU Session message flows for X2 based handover procedure, with I-SMF insertion/change/removal triggers charging message flows as below:

- I-SMF insertion message flows, for Xn based handover, refer to TS 23.502 [201], 4.23.11.2-1 step 1 to 9.
- I-SMF Change message flows, for Xn based handover, refer to TS 23.502 [201], 4.23.11.3-1 step 1 to 9,
- I-SMF Removal message flows, for Xn based handover, refer to TS 23.502 [201], 4.23.11.4-1 step 1 to 8.

x.ch-a. All counts are closed in SMF with the I-SMF, and a Charging Data Request [Update] message including I-SMF information and “insertion/change/removal of I-SMF” trigger is sent to CHF, if required by immediate report category trigger. New counts and time stamps for all active service data flows are started in the SMF.

x.ch-b. The CHF updates CDR for this PDU session.

x.ch-c. The CHF acknowledges by sending Charging Data Response [Update] message to the SMF.

NOTE 3: x in figure 5.2.2.13.5-3, refer to the last step number in the detail message flows. For I-SMF insertion or I-SMF change, x refers to 9. For I-SMF removal, x refers to 8.

**5.2.2.14.6 5GS to EPS handover using N26 interface with I-SMF removal**

When 5GS to EPS handover using N26 interface in idle mode, procedure in TS 23.502 [201] clause 4.23.12.2 is applicable.

When 5GS to EPS handover using N26 interface in active mode, procedure in TS 23.502 [201] clause 4.23.12.6 is applicable.

Upon UE moves from I-SMF service area to EPS service area, with both RAT Type change and I-SMF removal triggered, PGW-C+SMF and CHF will conduct below charging procedures:

x.ch-a. All counts are closed in PGW-C+SMF with a Charging Data Request [Update] message including I-SMF information and both “RAT Type change” and “removal of I-SMF” triggers are sent to CHF, if required by immediate report category trigger. New counts and time stamps for all active service data flows are started in the PGW-C+SMF.

x.ch-b. The CHF updates CDR for this PDU session.

x.ch-c. The CHF acknowledges by sending Charging Data Response [Update] message to the PGW-C+SMF.

NOTE 1: x refers to the last message step number with I-SMF removal in the detail message flows in TS 23.502 [201] clause 4.23.12.2 or clause 4.23.12.6.

#### 5.2.2.14.7 EPS to 5GS handover using N26 interface with I-SMF insertion

When EPS to 5GS handover using N26 interface in idle mode, procedure in TS 23.502 [201] clause 4.23.12.3 is applicable.

When EPS to 5GS handover using N26 interface in active mode, procedure in TS 23.502 [201] clause 4.23.12.7 is applicable.

Upon UE moves from EPS service area to I-SMF service area, with both RAT Type change and I-SMF insertion triggered, PGW-C+SMF and CHF conduct below charging procedures:

x.ch-a. All counts are closed in PGW-C+SMF with a Charging Data Request [Update] message including I-SMF information and both “RAT Type change” and “insertion of I-SMF” triggers are sent to CHF, if required by immediate report category trigger. New counts and time stamps for all active service data flows are started in the PGW-C+SMF.

x.ch-b. The CHF updates CDR for this PDU session.

x.ch-c. The CHF acknowledges by sending Charging Data Response [Update] message to the PGW-C+SMF.

NOTE 1: x refers to the last message step number with I-SMF insertion in the detail message flows in TS 23.502 [201] clause 4.23.12.3 or clause 4.23.12.7.

#### 5.2.2.14.8 Addition/removal/change of PSA and UL CL or BP controlled by I-SMF

This clause is based on TS 23.502 clause 4.23.9.1, 4.23.9.2 and 4.23.9.3 procedures, describes simplified procedures of addition/removal/change of PSA and UL CL or BP controlled by I-SMF, adding with charging message flow:

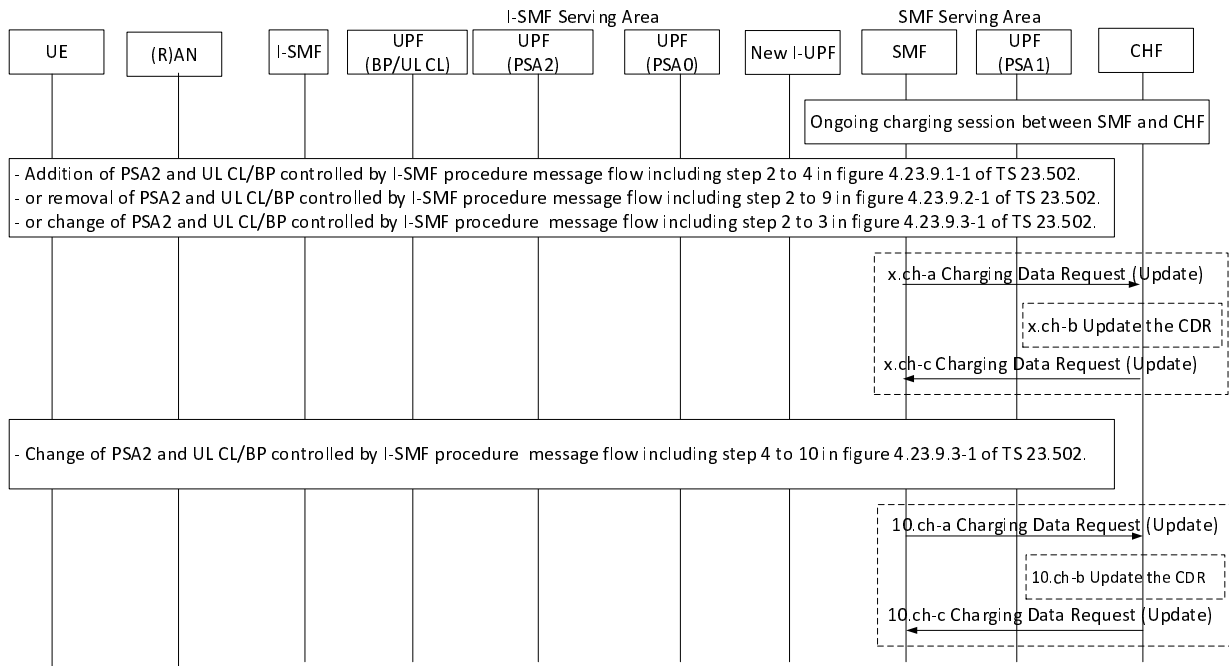

**Figure 5.2.2.14.8-1: Addition/removal/change of PSA and UL CL or BP controlled by I-SMF**

PDU Session served by both I-SMF and SMF has been established, with the ongoing Charging session.

PDU Session message flows with addition/removal/change of I-SMF controlled addition/removal/change of PSA and UL CL/BP with charging message flows as below:

- Addition of PDU Session Anchor (PSA2) for UL CL/BP controlled by I-SMF message flows, refer step 2 to step 4 described in figure 4.23.9.1-1 of TS 23.502[201].
- Removal of PDU Session Anchor (PSA2) for UL CL/BP controlled by I-SMF message flows, refer step 2 to step 9 described in figure 4.23.9.2-1 of TS 23.502[201].
- Change of PDU Session Anchor (PSA0 to PSA2) for UL CL/BP controlled by I-SMF message flows, refer step 2 to step 3 and step 4 to step 10 described in figure 4.23.9.3-1 of TS 23.502[201].

x.ch-a. All counts are closed in SMF for I-SMF controlled local PSA traffic, and a Charging Data Request [Update] message including I-SMF information and “addition/removal of UPF” trigger is sent to CHF, if required by immediate report category trigger. New counts and time stamps for all addition of PSA active service data flows are started in the SMF.

x.ch-b The CHF updates the CDR for this PDU Session.

x.ch-c. The CHF acknowledges by sending Charging Data Response [Update] to the SMF.

NOTE 1: x in figure 5.2.2.14.8-1, refer to the last step number in the detail message flows. For addition of PDU Session Anchor (PSA2), x refers to 4. For removal of PDU Session Anchor (PSA2), x refers to 9. For addition of PDU Session Anchor (PSA2) during change of PSA2, x refers to 3.

Removal of PDU Session Anchor (PSA0) for UL CL/BP controlled by I-SMF message flows, refer step 4 to step 10 described in figure 4.23.9.3-1 of TS 23.502[201].

10.ch-a. All counts are closed in SMF for I-SMF controlled the PSA0 traffic, and a Charging Data Request [Update] message including I-SMF information and “removal of UPF” trigger is sent to CHF, if required by immediate report category trigger.

10.ch-b The CHF updates the CDR for this PDU Session.

10.ch-c. The CHF acknowledges by sending Charging Data Response [Update] to the SMF.

NOTE 2: steps 10.ch-a to 10.ch-c are only applied in Change of PDU Session Anchor (PSA0 to PSA2) procedure.

### 5.2.2.14.9 Roaming Home routed PDU session - inter-PLMN V-SMF change

The following figure 5.2.2.14.9.1 describes the Home Routed PDU Session case in which the UE moves out of V-SMF service area in the serving PLMN to a new PLMN V-SMF service area, based on figure 4.23.4.3-1 of TS 23.502 [201], with I-SMF replaced by V-SMF in I-SMF change scenario:

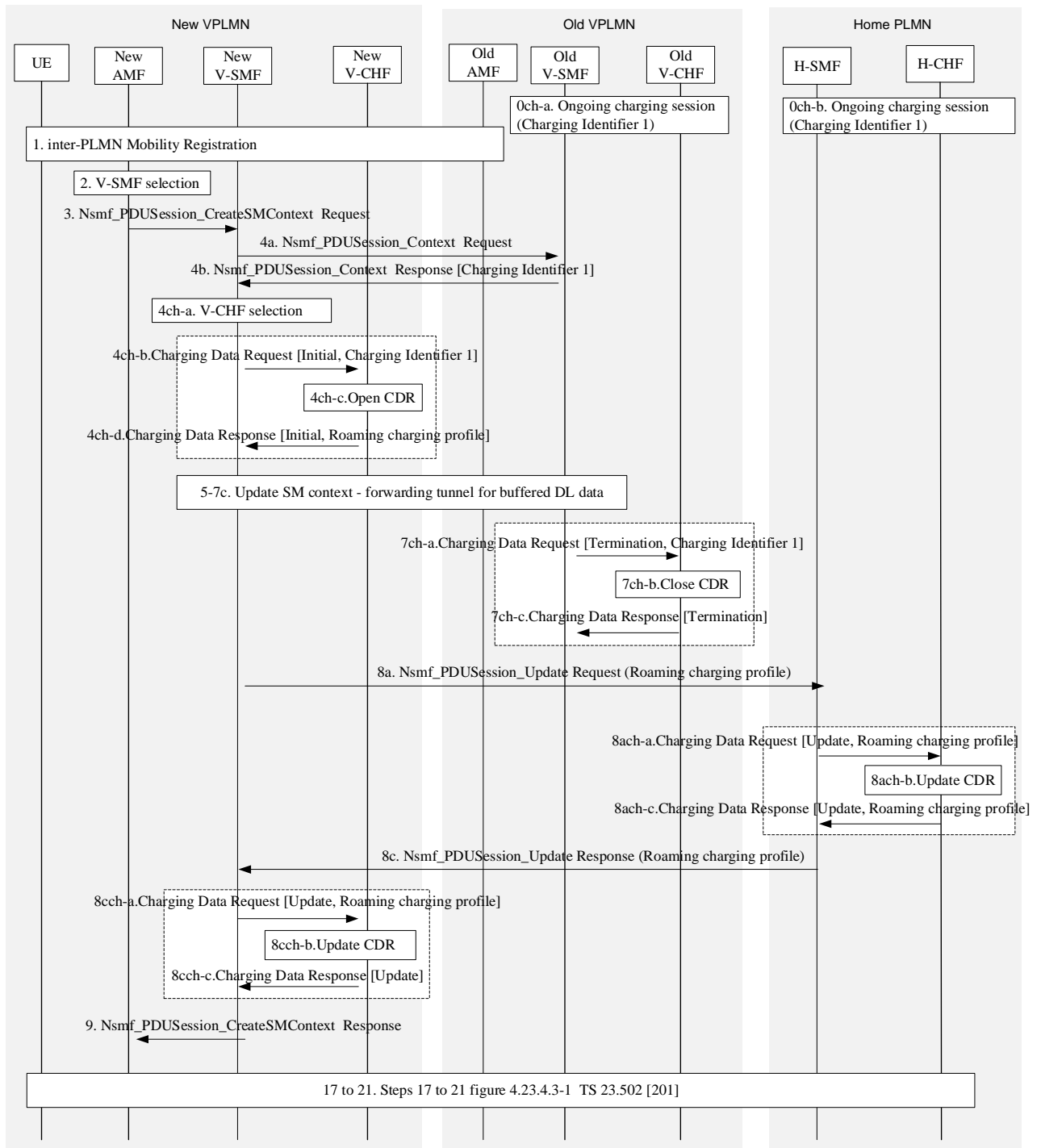

**Figure 5.2.2.14.9.1: Roaming Home routed PDU session inter-PLMN V-SMF change**

0ch-a: Ongoing charging session in old VPLMN for UE served by old V-SMF, using "Charging Identifier 1".



- 0ch-b: Ongoing charging session for HPLMN for UE served by old V-SMF, using "Charging Identifier 1".
- 1-2. UE moves into a different PLMN, and the new AMF determines the new V-SMF based on service area.
- 3- 4b. SM Context retrieval by new V-SMF from the old V-SMF. The "Charging Identifier 1" is conveyed to the new V-SMF.
- 4ch-a. The UE is identified as a roamer, the CHF is selected accordingly.
- 4ch-b. A Charging Data Request [Initial] is sent to new V-CHF, indicating "in-bound roamer" and "Charging Identifier 1" received on step 4b.
- 4ch-c. The new V-CHF opens a CDR (indicating "in-bound roamer").
- 4ch-d. The new V-CHF acknowledges by sending Charging Data Response [Initial] to new V-SMF and optionally supplies a "Roaming charging profile" to new V-SMF which overrides the default one.
- 5-7c. Refer steps 5 to 7c in Figure 4.23.4.3-1 of TS 23.502 [201].
- 7ch-a. A Charging Data Request [Termination] is sent to old V-CHF, with "Charging Identifier 1".
- 7ch-c. The old V-CHF closes the CDR.
- 7ch-d. The old V-CHF acknowledges by sending Charging Data Response [Initial] to old V-SMF.
- 8a. Nsmf\_PDUSession\_Update Request from new V-SMF towards the H-SMF with the "Roaming Charging Profile".
- 8ach-a. A Charging Data Request [Update] is sent to H-CHF in HPLMN, indicating the V-SMF change and "Roaming charging profile" received from the VPLMN.
- 8ach-b. The H-CHF in HPLMN updates the CDR.
- 8ach-c. The H-CHF in HPLMN acknowledges by sending Charging Data Response [Update] to the H-SMF and supplies the HPLMN selected "Roaming Charging Profile" for this VPLMN.
- 8c. Nsmf\_PDUSession\_Update Response from H-SMF to new V-SMF with the "Roaming charging profile".
- 8cch-a. A Charging Data Request [Update] is sent to V-CHF with charging information received from H-SMF, which includes the HPLMN selected "Roaming charging profile".
- 8cch-b. The V-CHF updates the CDR.
- 8cch-c. The V-CHF acknowledges by sending Charging Data Response [Update] to the V-SMF.
- 9, 17-21. Refer steps 9 and 17 to 21 in Figure 4.23.4.3-1 of TS 23.502 [201].

#### 5.2.2.14.10 Roaming Home routed PDU session - intra-PLMN V-SMF change

The following figure 5.2.2.14.10.1 describes the Home Routed PDU Session case in which the UE moves out of V-SMF service area in the serving PLMN to a new V-SMF service area in the serving PLMN, based on figure 4.23.4.3-1 of TS 23.502 [201], with I-SMF replaced by V-SMF in I-SMF change scenario:

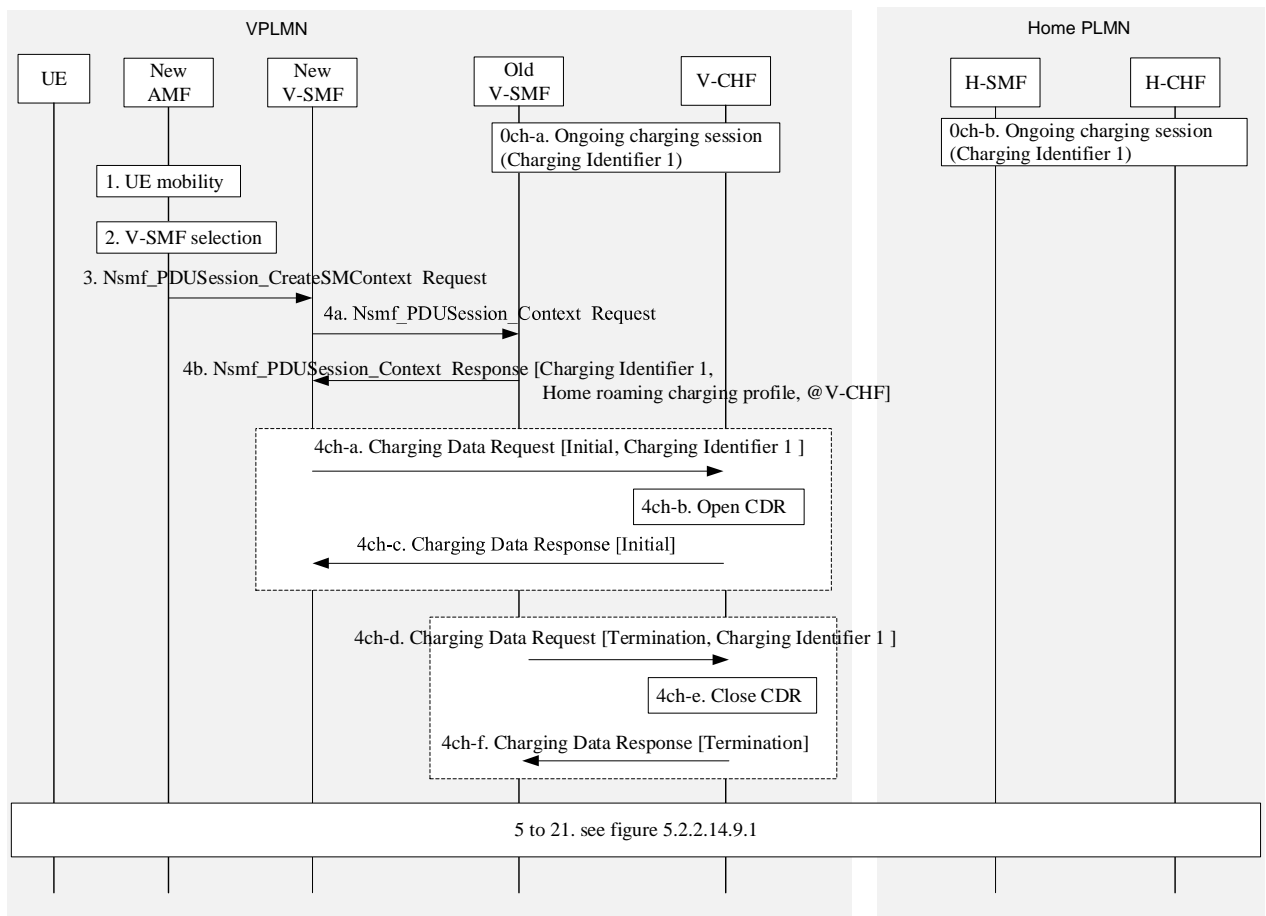

**Figure 5.2.2.14.10.1: Roaming Home routed PDU session intra-PLMN V-SMF change**

0ch-a and 0ch-b: same as in Figure 5.2.2.14.10.1.

1-2. UE moves out of the old V-SMF service area, and the new AMF determines the new V-SMF service area in the same VPLMN.

3- 4b. SM Context retrieval by new V-SMF from the old V-SMF. The "Charging Identifier 1", the "Home roaming charging profile", and the V-CHF address, are conveyed to the new V-SMF.

4ch-a. A Charging Data Request [Initial] is sent to V-CHF, indicating "in-bound roamer" and "Charging Identifier 1" received on step 4b.

NOTE: Since the same V-CHF is used, the "Home roaming charging profile" to be used is already known by the V-CHF

4ch-b. The V-CHF opens a CDR (indicating "in-bound roamer").

4ch-c. The V-CHF acknowledges by sending Charging Data Response [Initial] to new V-SMF.

4ch-d. A Charging Data Request [Termination] is sent to V-CHF, with "Charging Identifier 1".

4ch-e. The V-CHF closes the CDR.

4ch-f. The V-CHF acknowledges by sending Charging Data Response [Termination] to old V-SMF.

5-21. Same steps as in Figure 5.2.2.14.10.1, except the "Roaming charging profile" is not renegotiated, i.e., not contained in steps 8a, 8ach-a, 8ach-c, 8c and 8cch-a.

## 5.2.2.15 PDU session charging from SMF - ATSSS

### 5.2.2.15.1 General

This clause specifies PDU session charging for a MA PDU session as defined in TS 23.501 [200].

The flows are based on message flows specified in clause 4.22 TS 23.502 [201],

### 5.2.2.15.2 UE requested MA PDU session establishment

The following figure 5.2.2.15.2.1 describes charging procedure for MA PDU Session establishment requested by UE, based on figure 5.2.2.2.1 description with the following differences identified in clause 4.22.2.1 TS 23.502 [202]:

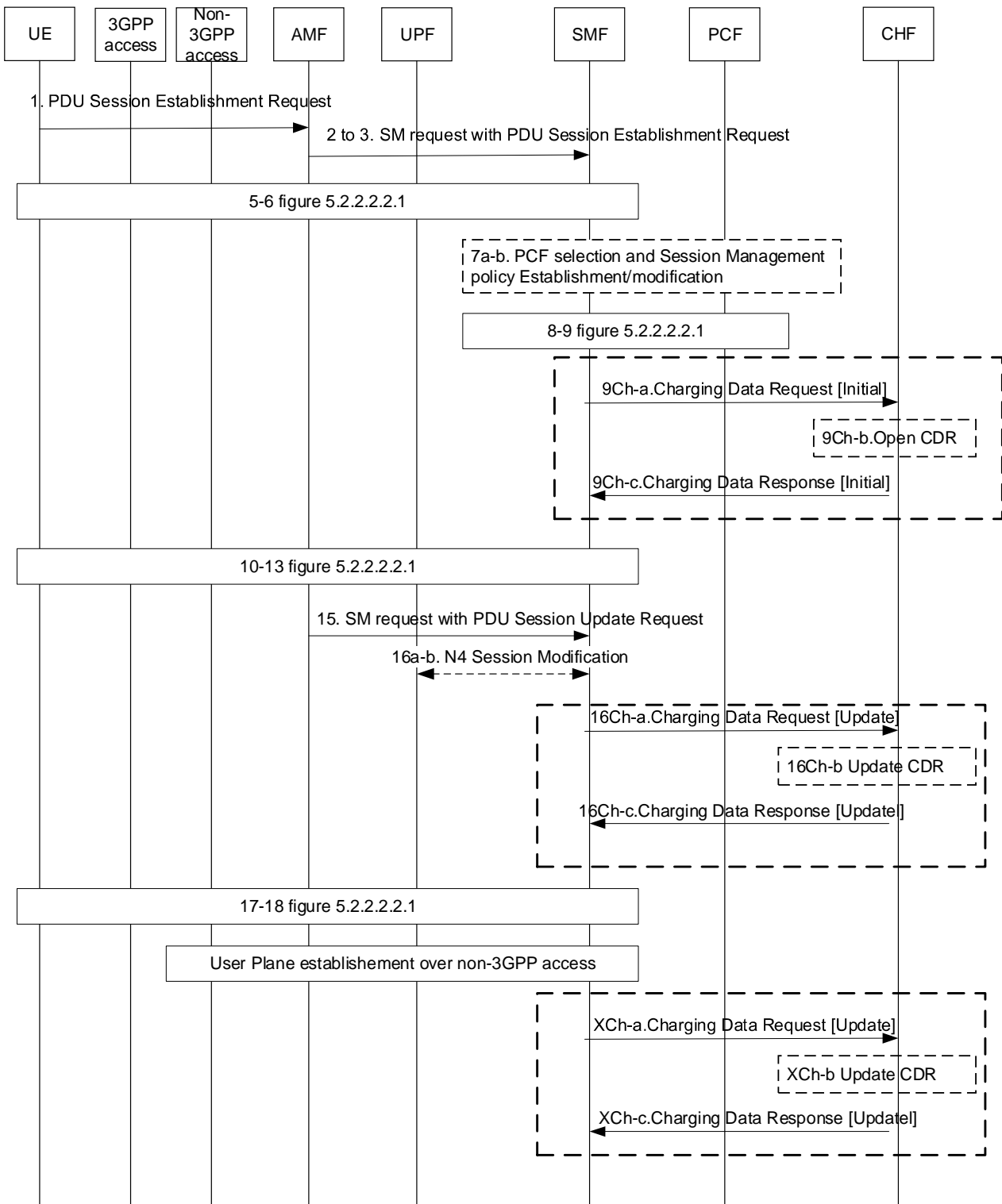

**Figure 5.2.2.15.2.1: UE Requested MA PDU session establishment**

- The UE is registered in both 3GPP access and non-3GPP access, and UE PDU Session Establishment Request message is sent over the 3GPP access.
- 1. PDU Session Establishment Request is indicated with "MA PDU Request" and ATSSS Capability (e.g. an "MPTCP Capability" and/or an "ATSSS-LL Capability").
- 2-3. The AMF informs the SMF that the request is for a MA PDU Session and indicates the UE is registered over both accesses.

7a-b. PCC Rules supplied by PCF contain ATSSS policy control information, optionally with a dedicated non-3GPP access rating group. From these PCC Rules, the SMF derives ATSSS rules for uplink and N4 rules for downlink for controlling the traffic steering, switching and splitting.

9ch-a. The SMF sends Charging Data Request [initial] indicating "MA PDU session requested by UE" to CHF for authorization for the subscriber to start the MA PDU session.

9ch-b. The CHF opens CDR for this MA PDU session.

9ch-c. The CHF acknowledges by sending Charging Data Response [Initial] to the SMF.

10-13. Procedure based on ATSSS policy and SMF derived both N4 Rules and ATSSS rules to UE.

16ch-a. This step may occur in case "start of service data flow" over 3GPP needs quota from CHF for appropriate rating group, the SMF sends Charging Data Request [Update] for requesting quota.

16ch-b. The CHF updates CDR for this MA PDU session.

16ch-c. The CHF acknowledges by sending Charging Data Response [Update] to the SMF.

After step 18 in figure 5.2.2.2.1, if the SMF was informed in step 2 that the UE is registered over both accesses, the SMF initiates the establishment of user-plane resources over non-3GPP access via AMF. After the user plane is established with the non-3GPP access:

Xch-a. The SMF sends Charging Data Request [Update]. This step may occur in case following chargeable events need quota from CHF for appropriate rating group, or if required by "immediate reporting" category:

- "start of SDF additional access" over non-3GPP.
- "start of service data flow" over non-3GPP or 3GPP.

Xch-b. The CHF updates CDR for this MA PDU session.

Xch-c. The CHF acknowledges by sending Charging Data Response [Update] to the SMF.

In the scenario where the PDU Session Establishment Request message for the MA PDU session is sent over the non-3GPP access, and the user plane over the non-3GPP access is established before the user plane over 3GPP:

16ch-a. This step may occur in case "start of service data flow" over non-3GPP needs quota from CHF for appropriate rating group, or if required by "immediate reporting" category

Xch-a. This step may occur in case following chargeable events need quota from CHF for appropriate rating group, or if required by "immediate reporting" category:

- "start of SDF additional access" over 3GPP.
- "start of service data flow" over non-3GPP or 3GPP.

### 5.2.2.15.3 UE requested PDU session establishment with Network Modification to MA PDU Session

The following flow describes the charging procedure for a single access PDU session establishment by ATSSS-capable UE and the 5GC network decides to convert to a Multi-Access PDU (MA PDU) Session, based on figure 5.2.2.2.1 description with the following differences identified in clause 4.22.3 TS 23.502 [202]:

- The UE is registered in both 3GPP access and non-3GPP access and sends a PDU Session Establishment Request message over the 3GPP access.

1. PDU Session Establishment Request may include "MA PDU Network-Upgrade Allowed" indication and its ATSSS Capability.7. The single-access PDU Session requested by the UE is converted into a MA PDU Session by SMF based on "MA PDU Network-Upgrade Allowed" indication, and PCC Rules are supplied by PCF containing ATSSS policy control information optionally with a dedicated non-3GPP access rating group.

9ch-a. The SMF sends Charging Data Request [initial] indicating "MA PDU session requested by Network modification" to CHF.

9ch-b. The CHF opens CDR for this MA PDU session.

9ch-c. The CHF acknowledges by sending Charging Data Response [Initial] to the SMF.

Steps after step 10 in clause 5.2.2.15.2 apply.

#### 5.2.2.15.4 UE Requested PDU Session Establishment with Network Modification to MA PDU Session - roaming in Home routed scenario

The charging procedure for single access PDU session establishment requested by ATSSS-capable UE and converted to a Multi-Access PDU (MA PDU) Session by the 5GC network in roaming Home routed scenario, is based on figures in clause 5.2.2.15.X. and description in clause 4.22.3 TS 23.502 [202].

##### 5.2.2.15.4.1 UE registered to the same VPLMN over 3GPP access and non-3GPP access

The charging procedure for UE registered to the same VPLMN over 3GPP access and non-3GPP access is based on figure 5.2.2.15.X.1.1 with differences identified in clause 4.22.3 TS 23.502 [202]:

- The UE is registered to the same VPLMN over 3GPP access and non-3GPP access, and UE PDU Session Establishment Request message is sent over the 3GPP access.

1-3a. UE PDU Session Establishment Request may include "MA PDU Network-Upgrade Allowed" indication and its ATSSS Capability. This indication may be conveyed by AMF to V-SMF.

6. The V-SMF provides the "MA PDU Network-Upgrade Allowed" indication to H-SMF, if received from AMF together with an indication whether the UE is registered over both accesses.

9a-b. The single-access PDU Session received by H-SMF with "MA PDU Network-Upgrade Allowed" indication is converted into a MA PDU Session. PCC Rules are supplied by PCF containing ATSSS policy control information optionally with a non-3GPP access dedicated rating group.

11ch-a to c. Same steps as in figure 5.2.2.12.2.1 with Charging Data Request [Initial] indicating "MA PDU session requested by the Network".

#### 5.2.2.15.5 UE requested MA PDU session establishment - roaming in Home routed scenario

##### 5.2.2.15.5.1 General

The charging procedure for MA PDU Session establishment requested by UE in roaming Home routed scenario is based on figure 5.2.2.12.2.1 and description in clause 4.22.2.2 TS 23.502 [202].

##### 5.2.2.15.5.2 UE registered to the same VPLMN over 3GPP access and non-3GPP access

The following figure 5.2.2.15.5.2.1 describes charging procedure for MA PDU session charging establishment requested by UE in roaming Home routed scenario for UE registered to the same VPLMN over 3GPP access and non-3GPP access:

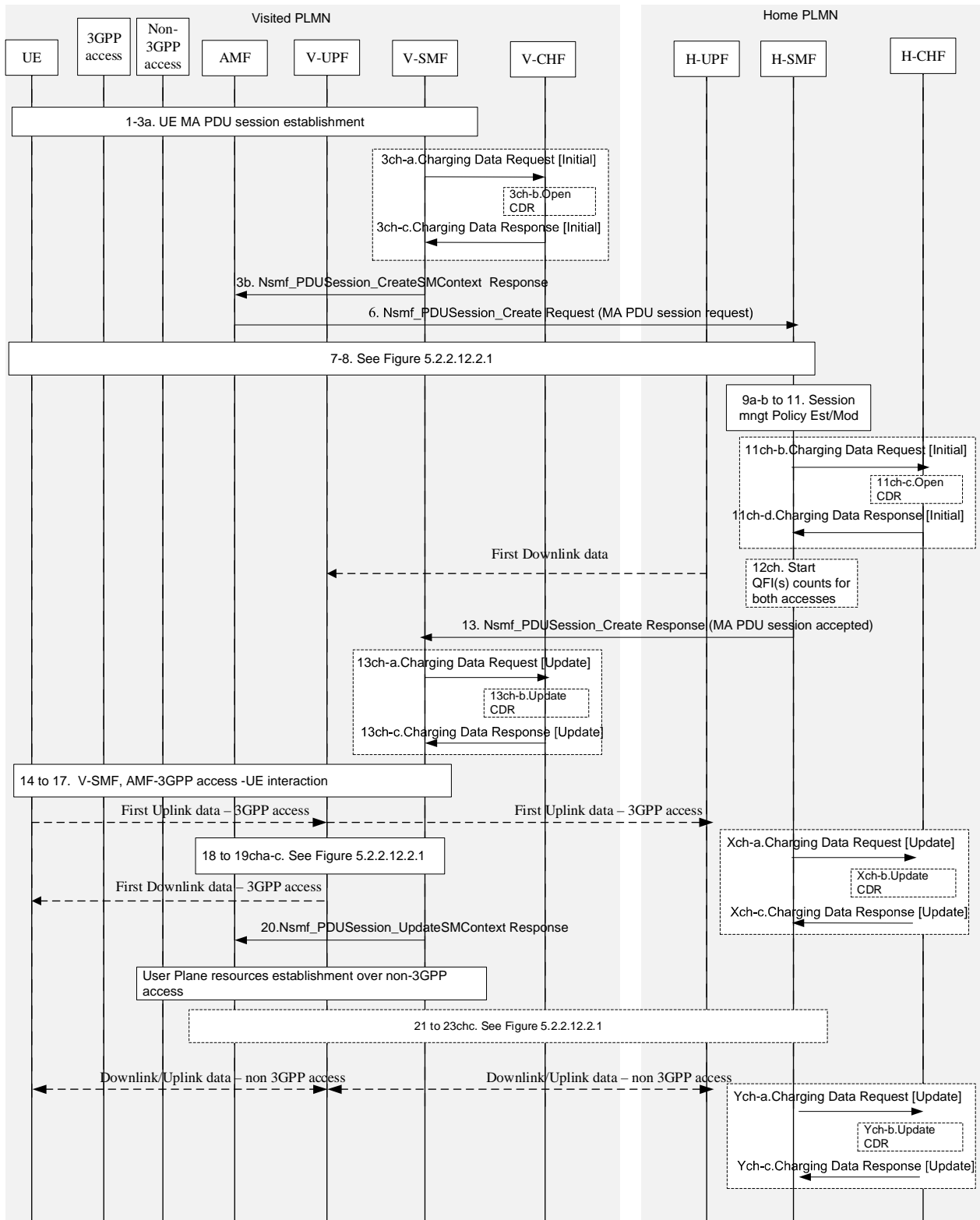

**Figure 5.2.2.15.5.2.1: UE requested MA PDU session - Roaming Home Routed - same VPLMN**

- The UE is registered to the same VPLMN over 3GPP access and non-3GPP access, and UE PDU Session Establishment Request message is sent over the 3GPP access.

1-3a. UE initiates a new PDU session indicated with "MA PDU Request" and ATSSS Capability. Selection by the AMF of V-SMF which supports MA PDU sessions. The AMF indicates to V-SMF that the UE is registered over both accesses

3ch-a to 3ch-d. Same steps as in figure 5.2.2.12.2.1.

6. The V-SMF informs the H-SMF that the request is for a MA PDU Session and the UE is registered over both accesses.
- 9a-b. PCC rules are supplied by H-PCF containing MA PDU session control information based on currently used list of Access Type(s) and RAT Type(s). The H-SMF initiates the establishment of user-plane resources over non-3GPP access and derives the ATSSS rules for the UE and the N4 rules for the H-UPF.
- 11ch-a to c. Same steps as in figure 5.2.2.12.2.1 with Charging Data Request [Initial] indicating "MA PDU session requested by UE".
- 12ch. Counts per QFI are started for both 3GPP and non-3GPP accesses.
13. Nsmf\_PDUSESSION\_Create Response from H-SMF to V-SMF with "MA PDU session Accepted" indication.
- 13ch-a to c. Same steps as in figure 5.2.2.12.2.1. Counts per QFI are started for both 3GPP and non-3GPP accesses.
- 14-19b. Procedure in the VPLMN for 3GPP access and based on H-SMF derived ATSSS rules to UE for the MA PDU session.
- Xch-a. The H-SMF sends Charging Data Request [Update]. This step may occur in case "start of service data flow" chargeable event over 3GPP, when required by "immediate reporting" category.
- Xch-b. The H-CHF updates CDR for this MA PDU session.
- Xch-c. The H-CHF acknowledges by sending Charging Data Response [Update] to the V-SMF.

After the user plane resources are established over non-3GPP access in VPLMN, and traffic goes through between VPLMN and HPLMN over non-3GPP access:

- Ych-a. The H-SMF sends Charging Data Request [Update] to H-CHF. This step may occur in case "start of service data flow" chargeable event over non-3GPP, when required by "immediate reporting" category.
- Ych-b. The H-CHF updates CDR for this MA PDU session.
- Ych-c. The H-CHF acknowledges by sending Charging Data Response [Update] to the V-SMF.

## 5.2.2.15.6 EPS interworking

### 5.2.2.15.6.1 5GS to EPS handover using N26 interface

The charging procedure for MA PDU Session 5GS to EPS handover using N26 interface scenario is based on figure 5.2.2.11.2.1 description with the differences identified in clause 4.22.6.2.1 TS 23.502 [202]:

- 0ch. A charging session between the PGW-C+SMF and CHF exists for the MA PDU Session with multiple QoS Flows over 3GPP access and non-3GPP access.
- 16ch-a. MA PDU session moved to EPS: All counts affected by the MA PDU session move to EPS are closed and a Charging Data Request [Update] is sent to CHF, if required by "RAT type change" trigger. New counts and time stamps for all active service data flows are started in the PGW-C+SMF.
- MA PDU Session Release procedure over non-3GPP access triggered by PGW-C+SMF: All counts affected by the release of non-3GPP access are closed by "Termination of service data flow" trigger.

### 5.2.2.15.6.2 5GS to EPS mobility without N26 interface

The charging procedure for MA PDU Session 5GS to EPS mobility without using N26 interface scenario is based on figure 5.2.2.11.6.1 description with the differences identified in clause 4.22.6.2.5 TS 23.502 [202]:

0. UE is registered in 5GS and MA PDU Session is over both 3GPP and non-3GPP accesses.
10. E-UTRAN Initial attach procedure:



10ch-a. MA PDU Session is moved to EPS: All counts affected by the MA PDU session move to EPS are closed and a Charging Data Request [Update] is sent to CHF, if required by "Handover start" trigger. New counts and time stamps for all active service data flows are started in the PGW-C+SMF

10ch-b. The CHF updates CDR for this PDU session.

10ch-c. The CHF acknowledges by sending Charging Data Response [Update] to the PGW-C+SMF.

The PGW-C + SMF triggers the MA PDU Session Release procedure over non-3GPP access: All counts affected by the release of non-3GPP access are closed by "Termination of service data flow" trigger.

14. The PGW-C+SMF initiates release of the 5GS MA PDU Session(s) transferred to EPS.

#### 5.2.2.15.7 Hybrid Access with Multi-Access PDU Session connectivity over NG-RAN and W-5GAN

The following flow describes the charging procedure for MA PDU Session establishment over NG-RAN and W-5GAN requested by 5G-RG, based on figure 5.2.2.15.2.1 description with the following differences identified in clause 4.12.2 TS 23.316 [203]:

- The UE is replaced by 5G-RG.
- Non-3GPP access(es) is specifically referred to wireline access.

When PDU Session Establishment Request message is sent over the 3GPP access (i.e. NG-RAN), or sent over the non-3GPP access (i.e. W-5GAN):

9ch-a. The SMF sends Charging Data Request [initial] to CHF for authorization for the 5G-RG to start the MA PDU session.

9ch-b. The CHF opens CDR for this MA PDU session.

9ch-c. The CHF acknowledges by sending Charging Data Response [Initial] to the SMF.

#### 5.2.2.15.8 Hybrid Access with multi-access connectivity over E-UTRAN/EPC and W-5GAN

The following flow describes the charging procedure for MA PDU Session establishment over E-UTRAN/EPC and W-5GAN requested by 5G-RG using EPC interworking procedures, based on clause 4.12.3 TS 23.316 [203]:

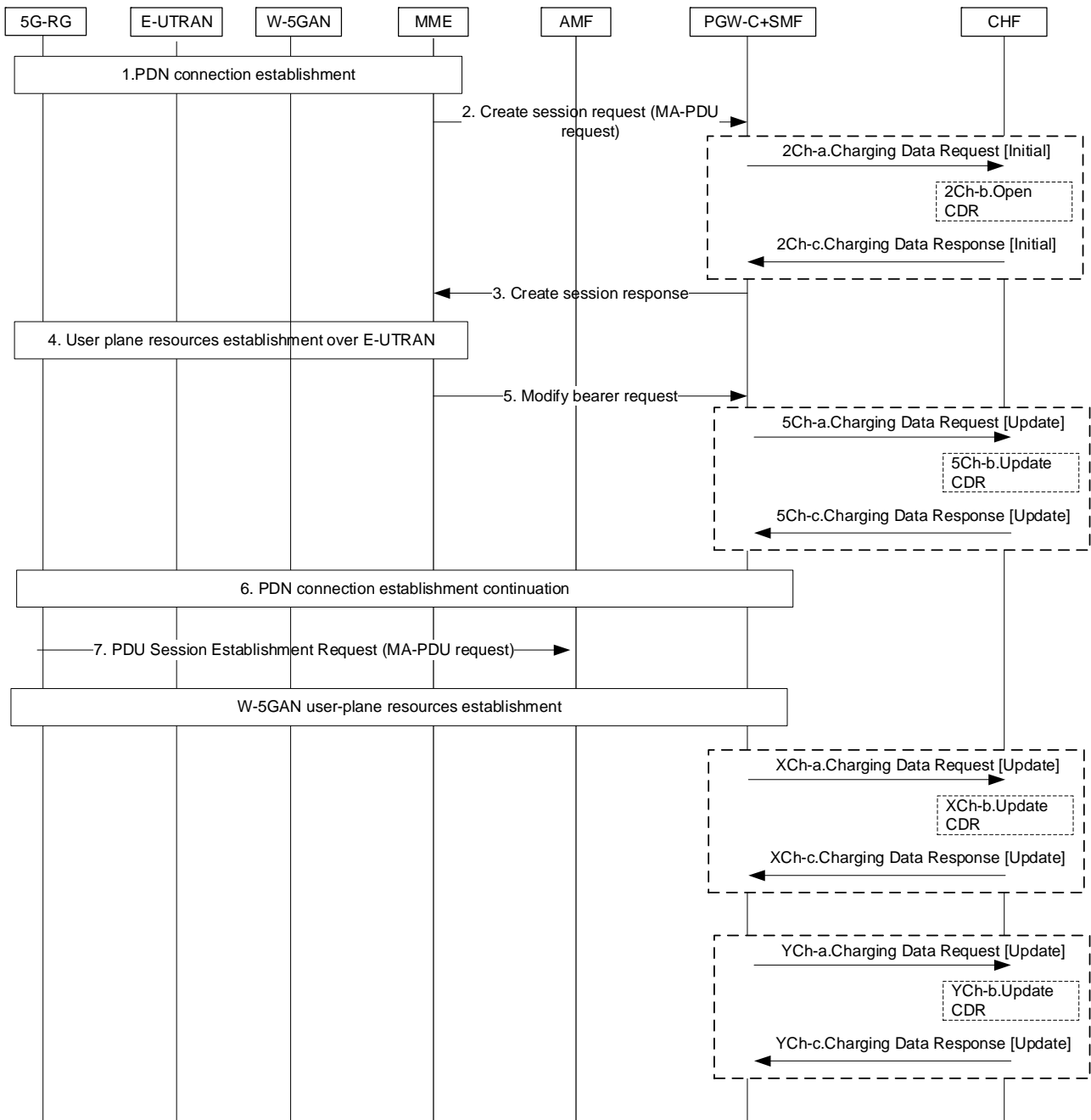

**Figure 5.2.2.15.8.1: MA PDU session establishment requested by 5G-RG via EPC**

- The 5G-RG is registered in EPC.
- 1. 5G-RG initiates PDN Connection establishment via E-UTRAN, indicating the PDN Connection is requested to be associated with a MA PDU Session and its "ATSSS-LL Capability".
- 2. Create session request in EPC to the selected PGW-C+SMF with the indication the PDN Connection is requested to be associated with a MA PDU Session.
  - 2ch-a. The PGW-C+ SMF sends Charging Data Request [initial] indicating "MA PDU session requested" to CHF for authorization for the 5G-RG to use the PDN connection for a MA PDU session.
  - 2ch-b. The CHF opens CDR for this PDN connection.
  - 2ch-c. The CHF acknowledges by sending Charging Data Response [Initial] to the PGW-C+ SMF.
- 3. Create session response indicating the request for using the PDN Connection for MA-PDU Session is accepted.

4-5. User Plane resources establishment for E-UTRAN

5ch-a. This step may occur in case "start of service data flow" over 3GPP needs quota from CHF for appropriate rating group, the PGW-C+ SMF sends Charging Data Request [Update] for requesting quota.

5ch-b. The CHF updates CDR for this PDN connection.

5ch-c. The CHF acknowledges by sending Charging Data Response [Update] to the PGW-C+ SMF.

6. PDN connection establishment continuation

7. 5G-RG sends a PDU Session Establishment Request indicating "MA PDU Request" to establish W-5GAN user-plane resources.

When the user plane is established with W-5GAN (X corresponds to step 16a-b of figure 5.2.2.2.1 for the W-5GAN):

Xch-a. The PGW-C+ SMF sends Charging Data Request [Update]. This step may occur if required by "addition of access" trigger.

Xch-b. The CHF updates CDR for this MA PDU session.

Xch-c. The CHF acknowledges by sending Charging Data Response [Update] to the SMF.

After the user plane is established:

Ych-a. The PGW-C+ SMF sends Charging Data Request [Update]. This step may occur in case "start of service data flow" chargeable event needs quota from CHF for appropriate rating group, or if required by "immediate reporting" category.

Ych-b. The CHF updates CDR for this MA PDU session.

Ych-c. The CHF acknowledges by sending Charging Data Response [Update] to the PGW-C+ SMF.

In the scenario where the MA PDU Session is requested via 5GC/W-5GAN, the 5G-RG is registered to EPC and user-plane resources are added on 3GPP access over EPC, the following applies:

MA PDU session establishment via 5GC/W-5GAN per figure 5.2.2.15.2.1 until step 18 with PDU Session Establishment Request message for the MA PDU session sent over W-5GAN (i.e. non-3GPP access).

After step 18 of figure 5.2.2.2.1, the 5G-RG sends a PDN Connection Establishment Request via E-UTRAN, indicating "handover" and "MA PDU Request".

When the user plane is established with E-UTRAN over EPC:

Xch-a. The PGW-C+ SMF sends Charging Data Request [Update]. This step may occur if required by "addition of access" trigger.

After the user plane is established with E-UTRAN over EPC:

Ych-a. This step may occur in case "start of service data flow" chargeable event needs quota from CHF for appropriate rating group, or if required by "immediate reporting" category.

## 5.2.2.16 PDU session charging – wireline access

### 5.2.2.16.1 General

After registration management procedures to 5GC via wireline access network, a PDU session can be established via this wireline access, as specified in TS 23.316 [203] for different scenarios:

- 5G-RG connected via NR-RAN and W-5GAN;
- FN-RG connected via W-5GAN.

### 5.2.2.16.2 5G-RG Requested PDU Session Establishment via W-5GAN

The following figure 5.2.2.16.2.1 describes charging when 5G-RG requests a PDU session establishment via W-AGF.

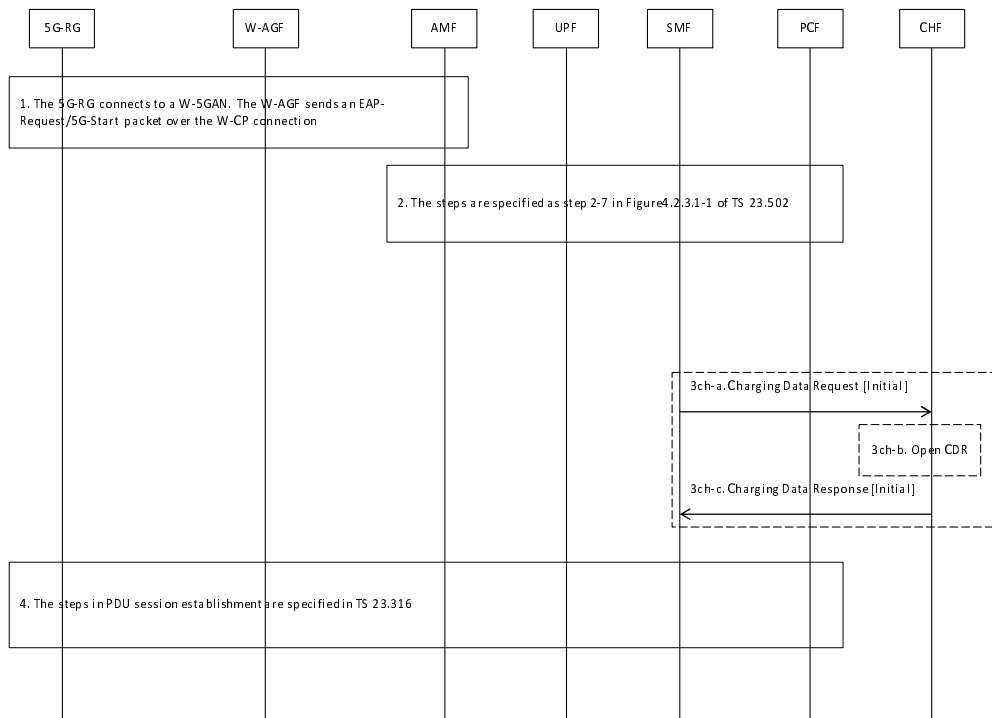

- 1) The 5G-RG connects to a W-5GAN and the W-AGF sends an EAP-Request/5G-Start packet over the W-CP connection as described in clause 7.3.1.1 in TS 23.316 [203].
- 2) The steps are specified as step 2-7 in clause 4.3.2.1 of TS 23.502 [202].
- 3ch-a. The SMF creates a Charging Identifier for the PDU session and sends Charging Data Request [Initial] to CHF for authorization for the subscriber information via wireline network to start the PDU session which is triggered by start of PDU session charging event.
- 3ch-b. The CHF opens CDR for this PDU session.
- 3ch-c. The CHF acknowledges by sending Charging Data Response [Initial] to the SMF.
- 4) The steps of PDU session establishment are specified in clause 7.3.1.1 of TS 23.316 [203].

### 5.2.2.16.3 FN-RG related PDU Session Establishment via W-5GAN

The following figure 5.2.2.16.3.1 describes charging when FN-RG requests a PDU session establishment via W-AGF. As described in clause 7.3.4 in TS 23.316 [203], after the registration procedure is completed, the W-AGF may establish PDU session(s) on behalf of the FN-RG.

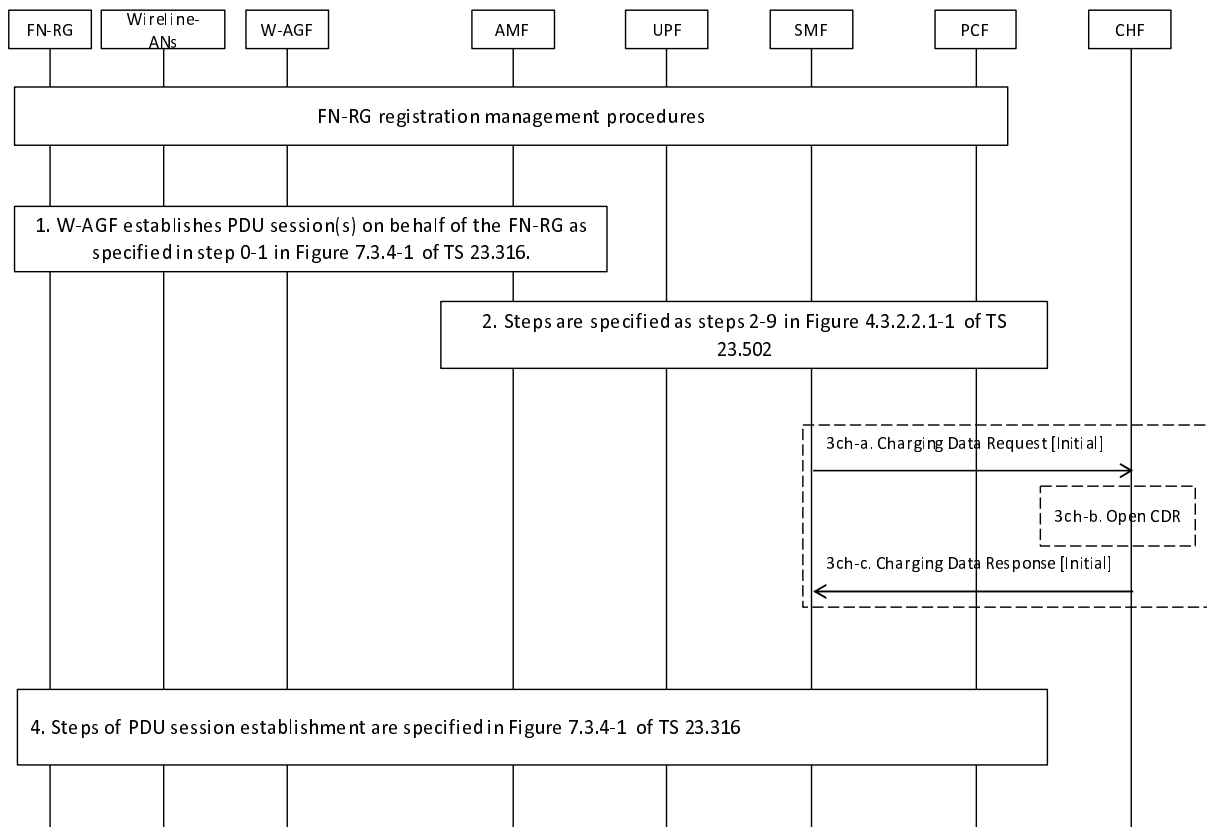

**Figure 5.2.2.16.3.1: charging when FN-RG requests a PDU session establishment via W-AGF**

- 1) After the registration procedure is completed, the W-AGF may establish PDU session(s) on behalf of the FN-RG as described in clause 7.3.4 in TS 23.316 [203].
- 2) The steps are specified as step 2-9 in clause 4.3.2.2.1 of TS 23.502 [202].
- 3ch-a. The SMF creates a Charging Identifier for the PDU session and sends Charging Data Request [Initial] to CHF for authorization for the subscriber identified under wireline network to start the PDU session which is triggered by start of PDU session charging event.
- 3ch-b. The CHF opens CDR for this PDU session.
- 3ch-c. The CHF acknowledges by sending Charging Data Response [Initial] to the SMF.
- 4) The steps of PDU session establishment are specified in clause 7.3.4 of TS 23.316 [203].

#### 5.2.2.16.4 Handover procedure

##### 5.2.2.16.4.1 5G RG handover of a PDU Session procedure from W-5GAN access to 3GPP access

Following figure 5.2.2.16.4.1.1 describes charging when 5G-RG handover of a PDU Session procedure from W-5GAN access to 3GPP access.

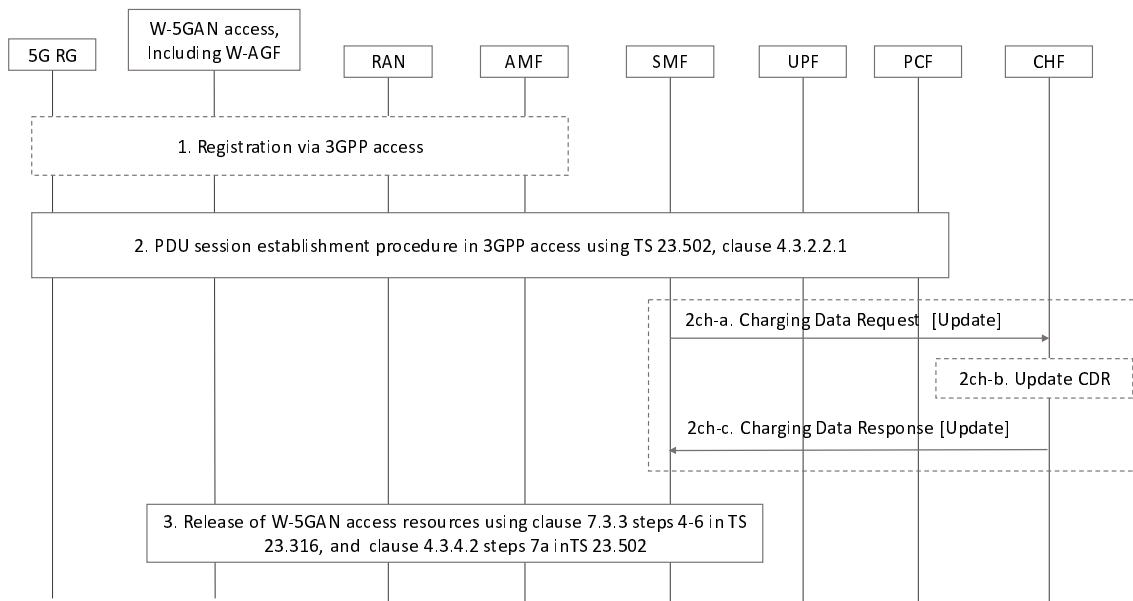

**Figure 5.2.2.16.4.1.1: Handover of PDU session from W-5GAN access to 3GPP access**

As described in clause 7.6.2.1 in TS 23.316 [203], the handover of a PDU session from W-5GAN access to 3GPP access is as following.

- 1-2) The steps are described in clause 7.6.2.1 in TS 23.316 [203], 5G-RG performs registration via 3GPP access and PDU session establishment procedure.
- 2ch-a-c. SMF may interact with CHF with Charging Data Request [Update]. This step occurs in case "RAT type change" triggers, if required by "immediate reporting" category. The RAT type change trigger, if enabled, applied during the PDU session establishment via the 3GPP access network before SMF executes the release of W-5GAN access resource. Which RAT type used is described in clause 5.3.2.3 of TS 23.501 [200].

NOTE: Void

- 3. The step that the SMF executes the release of resources in W-5GAN access is same as step 3 as described in clause 7.6.3.1 of TS 23.316 [203].

**5.2.2.16.4.2 5G RG handover of a PDU Session procedure from 3GPP to W-5GAN access**

Following figure 5.2.2.16.4.2.1 describes charging when 5G-RG handover of a PDU Session procedure from 3GPP to W-5GAN access.

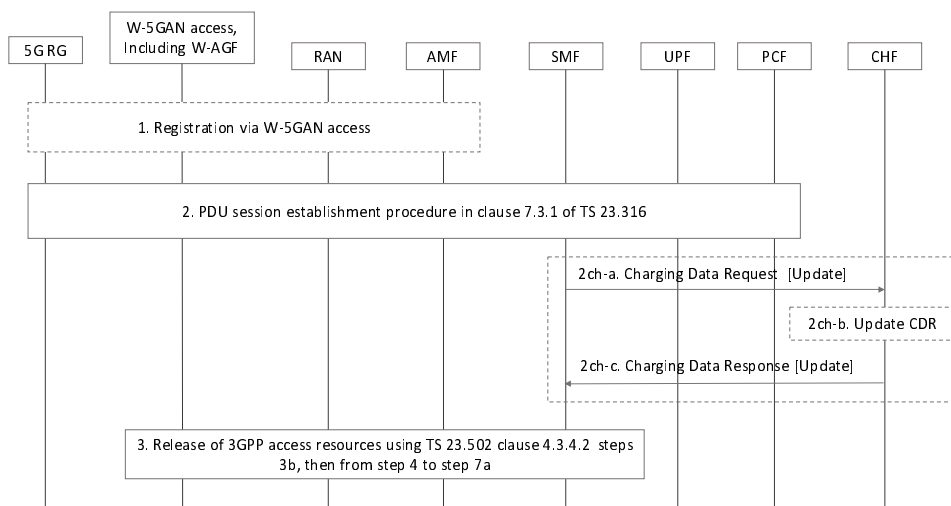

**Figure 5.2.2.16.4.2.1: Handover of a PDU Session procedure from 3GPP to W-5GAN access**

As described in clause 7.6.3.2 in TS 23.316 [203], the handover of a PDU session from 3GPP access to W-5GAN access is as following.

- 1) The 5G-RG initiates Reigstration procedure via W-5GAN as defined in clause 7.2.1.1 of TS 23.316 [203].
- 2) The 5G-RG performs PDU Session Establishment procedure via W-5GAN access as described in 7.6.3.2 of TS 23.316 [203].

2ch-a-c. SMF may interact with CHF with Charging Data Request [Update]. This step occurs in case "RAT type change" triggers, if required by "immediate reporting" category The RAT type change trigger, if enabled, applied during the PDU session establishment via the W-5GAN before SMF performs the release of 3GPP access resource. Which RAT type used is described in clause 5.3.2.3 of TS 23.501 [200].

NOTE: Void

- 3) The step that the SMF executes the release of resource via 3GPP access is same as step 3 as described in clause 7.6.3.2 of TS 23.316 [203].

## 5.2.2.17 Ultra Reliable Low Latency Communication (URLLC)

### 5.2.2.17.1 General

Support highly reliable URLLC services is specified in TS 23.501 [200] clause 5.33 procedures and TS 23.502 [201] message flows for different scenarios:

- Dual Connectivity based end to end Redundant User Plane Paths.
- Support of redundant transmission on N3/N9 interfaces.
- Support for redundant transmission at transport layer.

### 5.2.2.17.2 Void

### 5.2.2.17.3 Redundant transmission for high reliability communication

#### 5.2.2.17.3.1 PDU Session establishment

- Dual Connectivity based end to end Redundant User Plane Paths

The charging message flow of PDU session establishment for supporting Dual Connectivity based end to end Redundant User Plane Paths, is based on Figure 5.2.2.2.2-1 description with the differences identified in clause 4.3.2.2.1.1 TS 23.502 [202].

In the Step 9ch-a, if the PDU Session requires redundancy, SMF sends the Charging Data Request [Initial] with the redundant transmission information.

If the PDU session establishment without redundancy handling based on local policy, SMF sends the Charging Data Request [Initial] as described in Figure 5.2.2.2.2-1. CHF considers the PDU session is used for the non-redundant transmission.

- Redundant transmission on N3/N9 interfaces

The charging message flow of PDU session establishment for supporting redundant transmission on N3/N9 interfaces, is based on Figure 5.2.2.2.2-1 description with the differences identified in clause 4.3.2.2.1.1 TS 23.502 [202].

As described in clause 5.33.1.2 of TS 23.501 [201], SMF decides to perform redundant transmission for one or more QoS Flows at the step 10.

In the Step 16ch-a, the SMF sends the Charging Data Request [Update] with the redundant transmission information.

- Redundant transmission at transport layer

The charging message flow of PDU session establishment for supporting redundant transmission at transport layer, is based on Figure 5.2.2.2.2-1 description with the differences identified in clause 4.3.2.2.1.1 TS 23.502 [202].

As per the clause 5.33.2.3 TS 23.501[201], the knowledge of supporting redundant transmission at transport layer can be configured in the SMF, or be configured in UPF and then obtained by the SMF via N4 capability negotiation during N4 Association setup procedure.

In the Step 16ch-a, SMF sends the Charging Data Request [Update] with the redundant transmission information.

#### 5.2.2.17.3.2 PDU Session Modification

For redundant transmission on N3/N9 interfaces, the charging message flow of PDU session modification is based on Figure 5.2.2.2.3-1 description with the differences identified in clause 4.3.3.2 TS 23.502 [202].

2ch-a. If redundant transmission has not been activated to the PDU session and the SMF performs redundant transmission for the QoS Flow in step 2a, the SMF sends Charging Data Request [Update] to the CHF for the PDU session, with the trigger "Redundant transmission change".

If redundant transmission has been activated on the PDU Session, and the SMF stops redundant transmission in step 2a, the SMF sends Charging Data Request [Update] to the CHF for the PDU session, with the trigger "Redundant transmission change".

2ch-b. The CHF update the CDR for the URLLC.

2ch-c. The CHF acknowledges by sending Charging Data Response [Update] to the SMF.

#### 5.2.2.17.3.3 PDU Session Release

For redundant transmission on N3/N9 interfaces, the charging message flow of PDU session release is based on Figure 5.2.2.2.4-1 description with the differences identified in clause 4.3.4.2 TS 23.502 [202].

2ch-a. The SMF sends Charging Data Request [Termination] to the CHF for terminating the charging associated with PDU session in each UPF, with the trigger "End of PDU session".

2ch-b. The CHF closes the CDR for the URLLC.

2ch-c. The CHF acknowledges by sending Charging Data Response [Termination] to the SMF.



## 5.2.2.18 PDU session charging for roaming in Local breakout scenario

### 5.2.2.18.1 General

The clause below describes PDU session charging in roaming with local breakout scenarios.

### 5.2.2.18.2 PDU session establishment

The following figure 5.2.2.18.2-1 describes a PDU session establishment charging, based on figure 4.3.2.2.1-1 UE-requested PDU Session Establishment for non-roaming and roaming with local breakout TS 23.502 [202] description:

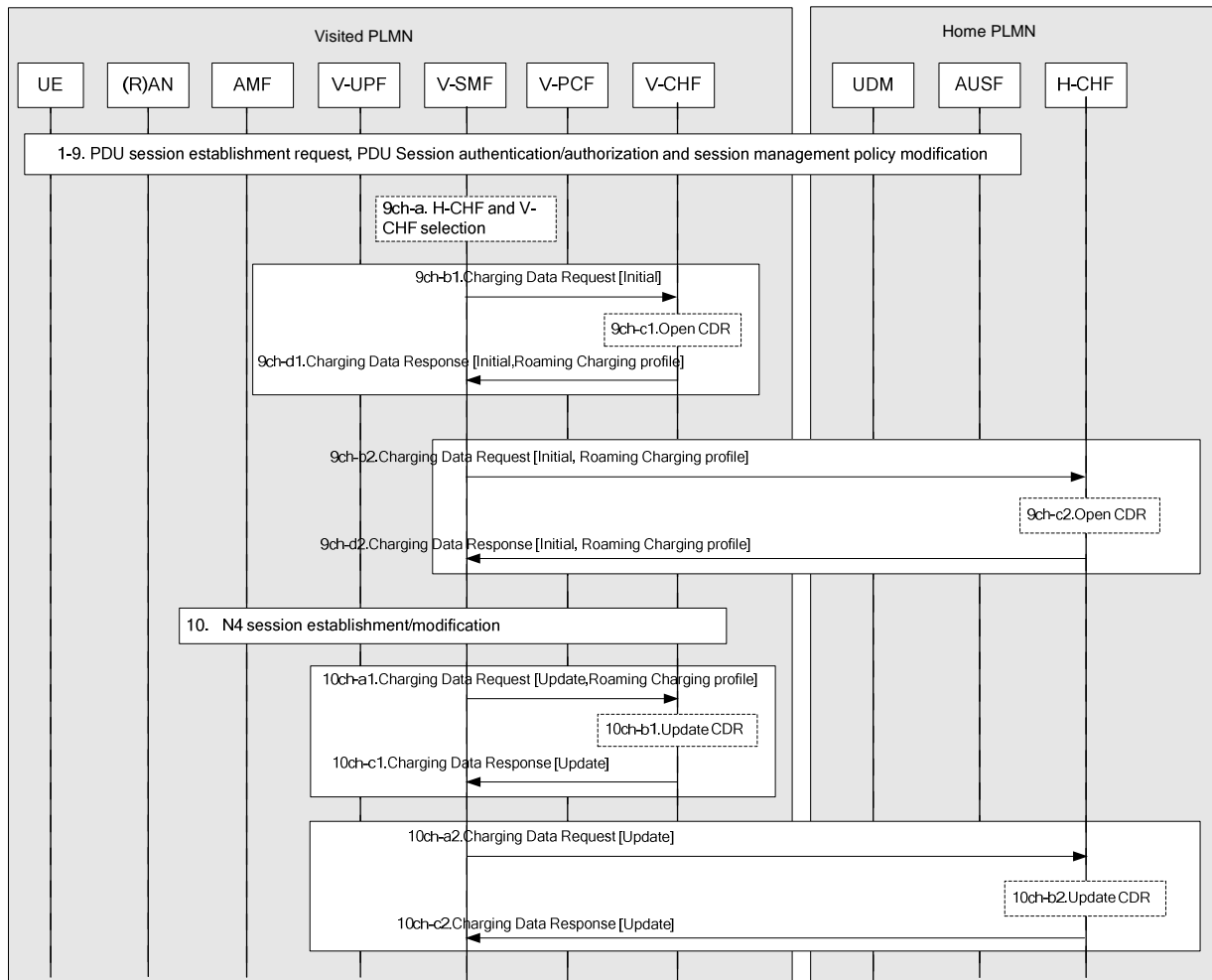

**Figure 5.2.2.18.2-1: PDU session establishment**

9ch-a. The UE is identified as a roamer (e.g., PLMN ID of the received SUPI is different from VPLMN PLMN ID), the V-CHF and optionally H-CHF are selected accordingly.

9ch-b1. The Charging Data Request [Initial] is sent to V-CHF, for the subscriber triggered by start of PDU session charging event.

9ch-c1. The V-CHF opens a CDR.

9ch-d1. The V-CHF acknowledges by sending Charging Data Response [Initial] to the V-SMF and optionally supplies a "Roaming charging profile" to the V-SMF (which overrides the default one).

9ch-b2. If a H-CHF was selected a Charging Data Request [Initial] is sent to H-CHF, with Charging Identifier, and with or without quota management and optionally including the "Roaming charging profile".

9ch-c2. The H-CHF opens a CDR.

9ch-d2. The H-CHF acknowledges by sending Charging Data Response [Initial] to the V-SMF and optionally supplies a "Roaming charging profile" to the V-SMF.

10ch-a1. The Charging Data Request [Update] is sent to V-CHF with QBC and/or FBC information, when enabled triggers are met, optionally including the new "Roaming charging profile".

10ch-b1. The V-CHF update the CDR.

10ch-c1. The V-CHF acknowledges by sending Charging Data Response [Update] to the V-SMF.

10ch-a2. If a H-CHF was selected a Charging Data Request [Update] is sent to H-CHF with QBC and/or FBC information, when enabled triggers are met, for FBC it may include a request for quota.

10ch-b2. The H-CHF update the CDR.

10ch-c2. The H-CHF acknowledges by sending Charging Data Response [Update] to the V-SMF.

### 5.2.2.18.3 PDU Session Modification

The following figure 5.2.2.18.3-1 describes the PDU session modification charging, based on figure 4.3.3.2-1 UE or network requested PDU Session Modification (for non-roaming and roaming with local breakout) TS 23.502 [202] description:

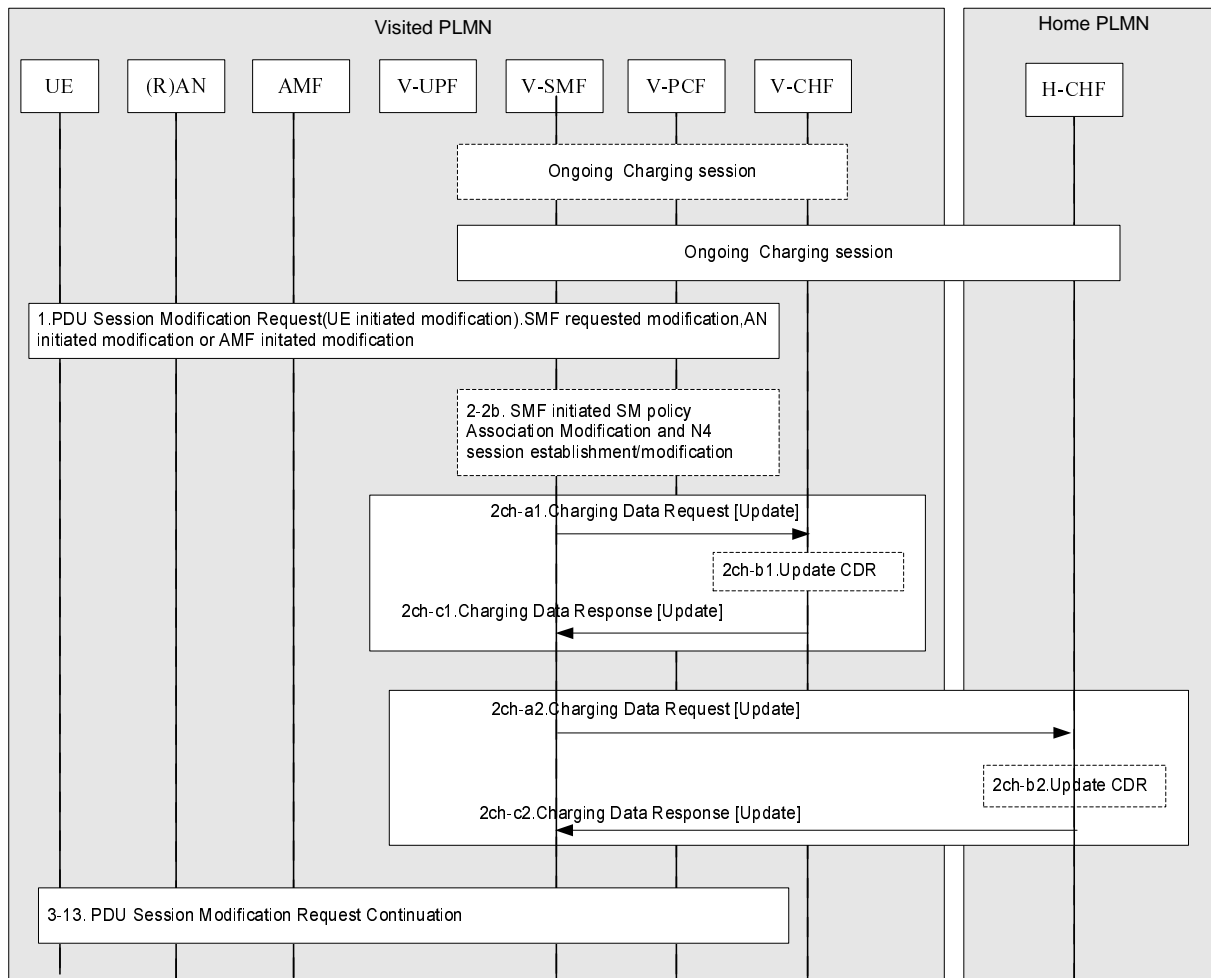

Figure 5.2.2.18.3-1: PDU Session Modification

2ch-a1. The Charging Data Request [Update] is sent to V-CHF for reporting the QBC and/or FBC information when enabled triggers are met.

2ch-b1. The V-CHF update the CDR.

- 2ch-c1. The V-CHF acknowledges by sending Charging Data Response [Update] to the V-SMF.
- 2ch-a2. If a H-CHF was selected a Charging Data Request [Update] is sent to H-CHF with QBC and/or FBC information, when the enabled triggers are met, and for FBC it may include a request for quota.
- 2ch-b2. The H-CHF update a CDR.
- 2ch-c2. The H-CHF acknowledges by sending Charging Data Response [Update] to the V-SMF.

### 5.2.2.18.4 PDU Session Release

The following figure 5.2.2.18.4-1 describes the PDU session release charging, based on figure 4.3.4.2-1 UE or network requested PDU Session Release for non-roaming and roaming with local breakout TS 23.502 [202] description:

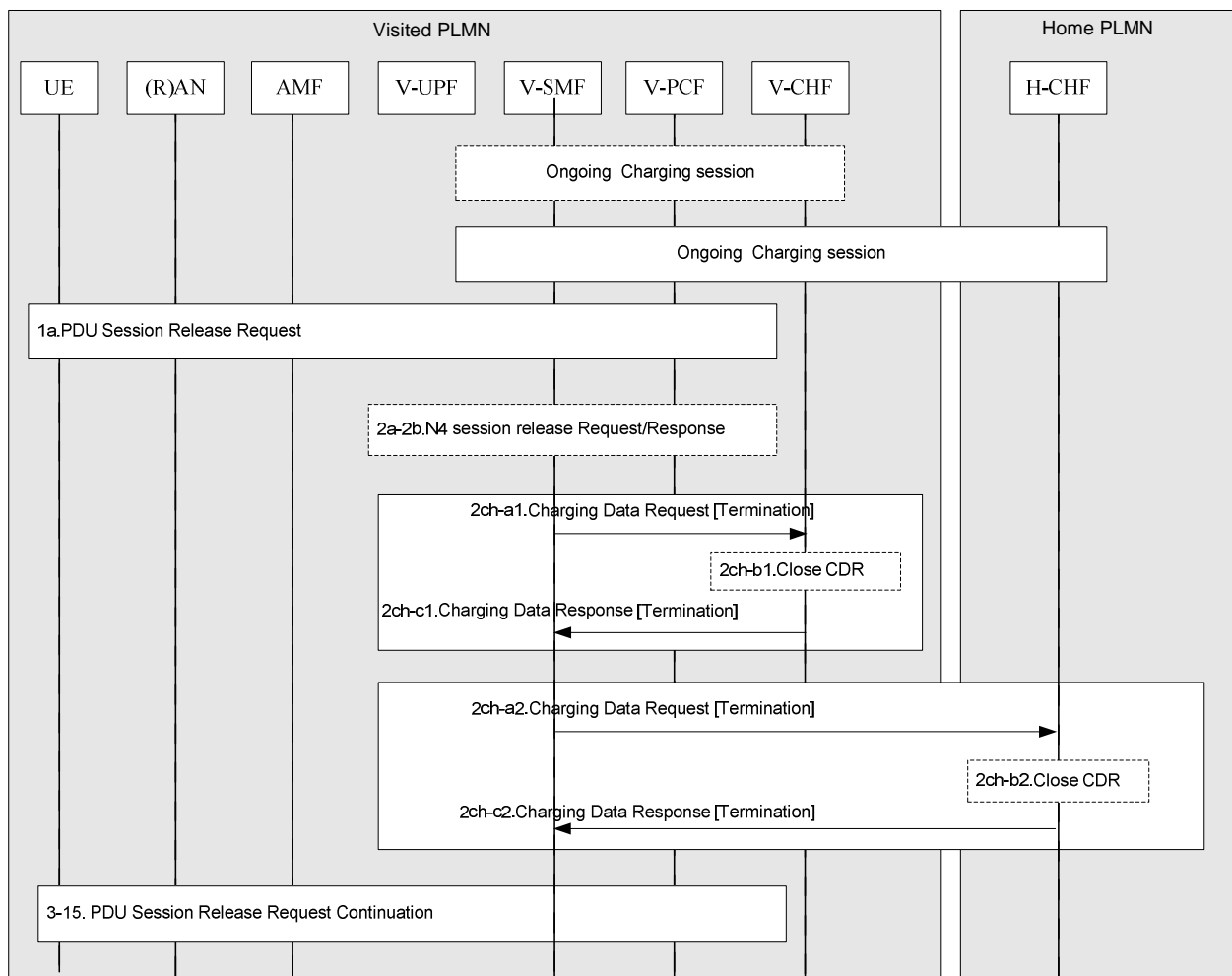

**Figure 5.2.2.18.4-1: PDU Session Release**

- 2ch-a1. The Charging Data Request [Termination] is sent to V-CHF.
- 2ch-b1. The V-CHF close the CDR.
- 2ch-c1. The V-CHF acknowledges by sending Charging Data Response [Termination] to the V-SMF.
- 2ch-a2. If a H-CHF was selected a Charging Data Request [Termination] is sent to H-CHF.
- 2ch-b2. The H-CHF close the CDR.
- 2ch-c2. The H-CHF acknowledges by sending Charging Data Response [Termination] to the V-SMF.

## 5.2.2.19 PDU session charging for additional actor (MVNO)

### 5.2.2.19.1 General

The clause below describes PDU session charging for additional actor (MVNO) which is only applicable for non-roaming case.

### 5.2.2.19.2 Additional actor (MVNO)

The clause contains the description for the scenario of MVNO as additional actor with A-CHF.

For non-roaming scenarios, the message flows for the PDU session establishment, PDU session Modification and PDU session Release for LBO charging specified in clause 5.2.2.18 could be applicable depending on the deployment scenarios for additional actor (MVNO), with the following differences:

- V-SMF in V-PLMN is replaced by the SMF in MNO;
- V-CHF in V-PLMN is replaced by the CHF in MNO;
- H-CHF in H-PLMN is replaced by the A-CHF in MVNO.

## 5.2.3 CDR generation

### 5.2.3.1 Introduction

The CHF CDRs for PDU session charging and roaming QBC are generated by the CHF to collect charging information that they subsequently transfer to the Charging Gateway Function (CGF).

The following clauses describe in detail the conditions for opening, adding information to, and closing the CHF CDR.

### 5.2.3.2 Triggers for CHF CDR

#### 5.2.3.2.1 General

A PDU session charging CHF CDR is used to collect charging information related to the PDU session data information for a UE in Flow Based Charging. Multiple service data flow containers per PDU session can be added in the CHF CDR by the CHF, upon receiving a Charging Data Request including new counts as defined in subclause 5.2.1.1.

A CHF CDR shall be opened when the CHF receives Charging Data Request[Initial].

As an alternative to the default CHF behaviour, the "Individual Partial record" mechanism can be used based on Operator's policy configured in the CHF. In this case a new CDR shall be opened for each Charging Data Request[Initial, Update, Termination], charging information shall be added and the CDR shall then be closed. The Sequence Number will be incremented for each Charging Data Request[Initial, Update, Termination] received by the CHF.

#### 5.2.3.2.2 Triggers for CHF CDR charging information addition

When the CHF receives Charging Data Request[Update], with the change conditions identified in Table 5.2.3.2.2.1 the charging information shall be added in the PDU session charging CHF CDR, and the CDR shall remain open, as the default supported mechanism.

**Table 5.2.3.2.2.1: Triggers for CHF CDR charging information addition**

Trigger Conditions	Applicable for converged charging	Applicable for offline only charging
Change of Charging conditions		
QoS change	Yes	Yes
User Location change	Yes	Yes
Serving Node change	Yes	Yes
Change of UE presence in Presence Reporting Area(s)	Yes	Yes
Change of 3GPP PS Data off Status	Yes	Yes
Handover cancel	Yes	Yes
Handover start	Yes	Yes
Limit per Rating Group		
Expiry of data time limit per RG	Yes	Yes
Expiry of data volume limit per RG	Yes	Yes
Expiry of data event limit per RG	Yes	Yes
Quota management triggers		
Time threshold reached	Yes	No
Volume threshold reached	Yes	No
Unit threshold reached	Yes	No
Time quota exhausted	Yes	No
Volume quota exhausted	Yes	No
Unit quota exhausted	Yes	No
Expiry of quota validity time	Yes	No
Re-authorization request by CHF	Yes	No

In case the "Individual Partial record" mechanism is enabled, the Table 5.2.3.2.2.1 is not applicable. The charging information consists of a set of containers, which are added as "List of Multiple Unit Usage" parameter of the CHF CDR. Each container identifies the configured counts (volume separated for uplink and downlink, elapsed time or number of events) per rating group or combination of the rating group and service id, associated with the changed charging conditions.

### 5.2.3.2.3 Triggers for CHF CDR partial record closure

When the CHF receives Charging Data Request [Update], with the change conditions identified in Table 5.2.3.2.3.1, the charging information shall be added in the PDU session charging CHF CDR, before the CDR is closed and a subsequent CHF CDR shall be opened with an incremented Sequence Number, as the default supported mechanism.

**Table 5.2.3.2.3.1: Triggers for CHF CDR partial record closure**

Trigger Conditions
Change of Charging conditions
UE time zone change
PLMN change
RAT type change
Session-AMBR change
Removal of UPF
Insertion_of_ISMF
Change_of_ISMF
Removal_of_ISMF
Handover complete
Management intervention
Addition of access
Removal of access
Limit per PDU session
Expiry of data time limit per PDU session
Expiry of data volume limit per PDU session
Expiry of data event limit per PDU session
Expiry of limit of number of charging condition changes

In case the "Individual Partial record" mechanism is enabled, the Table 5.2.3.2.3.1 is not applicable.

#### 5.2.3.2.4 Triggers for CHF CDR closure

When the CHF receives Charging Data Request[Termination], the charging information shall be added in the PDU session charging CHF CDR and the CDR shall be closed.

#### 5.2.3.3 Triggers for CHF CDR for roaming QBC

##### 5.2.3.3.1 General

A Roaming QBC CHF CDR is used to collect charging information related to Roaming QBC in V-SMF, and the PDU session charging CHF CDR is used to collect charging information related to Roaming QBC in H-SMF. QoS flow containers per PDU session can be added in the CHF CDRs by the CHF, upon receiving a Charging Data Request.

The charging information received from the CHF consists of a set of containers, which are added as "List Multiple QFI container" parameter of the CHF CDRs. Each container identifies the configured counts (volume separated for uplink and downlink, elapsed time) per QoS Flow, associated with the changed charging conditions.

A roaming CHF CDR shall be opened when the CHF receives Charging Data Request[Initial] indicating "in-bound roamer".

##### 5.2.3.3.2 Triggers for CHF CDR charging information addition for roaming QBC

When the CHF receives Charging Data Request[Update], with the change conditions identified in Table 5.2.3.3.2.1 the charging information shall be added in the CHFCDR, and the CDR shall remain open, as the default supported mechanism.

**Table 5.2.3.3.2.1: Triggers for CHF CDR charging information addition for roaming QBC**

Trigger Conditions
Change of Charging conditions
QoS change
User Location change
Serving Node change
Change of 3GPP PS Data off Status
Limit per QoS Flow
Expiry of data time limit per QoS Flow
Expiry of data volume limit per QoS Flow
Others
End of QoS Flow

In case the "Individual partial record" mechanism is enabled, this sub-clause is not applicable.

### 5.2.3.3.3 Triggers for CHF CDR partial record closure for roaming QBC

When the CHF receives Charging Data Request [Update] with the change conditions identified in Table 5.2.3.3.3.1, the charging information shall be added in the CHF CDR, before the CDR is closed and a subsequent CHF CDR shall be opened with an incremented Sequence Number, as the default supported mechanism.

**Table 5.2.3.3.3.1: Triggers for CHF CDR partial record closure for roaming QBC**

Trigger Conditions
Change of Charging conditions
UE time zone change
PLMN change
RAT type change
Session-AMBR change
Removal of UPF
Management intervention
Limit per PDU session
Expiry of data time limit per PDU session
Expiry of data volume limit per PDU session
Expiry of data event limit per PDU session
Expiry of limit of number of charging condition changes

In case the "Individual partial record" mechanism is enabled, the Table 5.2.3.3.3.1 is not relevant: instead, the charging information shall be added in the CHF CDR, before the CDR is closed and a subsequent CHF CDR shall be opened with an incremented Sequence Number for each Charging Data Request [Update] received by the CHF.

### 5.2.3.3.4 Triggers for roaming QBC CHF CDR closure

When the CHF receives Charging Data Request[Termination], the charging information shall be added in the roaming QBC CHF CDR and the CDR shall be closed.

## 5.2.4 Ga record transfer flows

In 5G, both fully qualified partial CDRs (FQPC) and reduced partial CDRs (RPC), as specified in TS 32.240 [1] may be supported on the Ga interface. In line with TS 32.240 [13], the support of FQPCs is mandatory, the support of RPCs is optional. For further details on the Ga protocol application refer to TS 32.295 [54].

## 5.2.5 Bd CDR file transfer

In 5G, both fully qualified partial CDRs (FQPC) and reduced partial CDRs (RPC), as specified in TS 32.240 [1] may be supported on the Bd interface. In line with TS 32.240 [13], the support of FQPCs is mandatory, the support of RPCs is optional. For further details on the Bd protocol application refer to TS 32.297 [52].

---

## 6. Definition of charging information

### 6.1 Data description for 5G data connectivity charging

#### 6.1.1 Message contents

##### 6.1.1.1 General

The Charging Data Request and Charging Data Response are specified in TS 32.290 [57] and include charging information. The Charging Data Request can be of type [Initial, Update, Termination].

Table 6.1.1.1.1 describes the use of these messages for converged charging.

**Table 6.1.1.1.1: Converged charging messages reference table**

Message	Source	Destination
Charging Data Request	SMF	CHF
Charging Data Response	CHF	SMF

The following clauses describe the different fields used in the Charging Data messages and the category in the tables is used according to the charging data configuration defined in clause 5.4 of TS 32.240 [1].



### 6.1.1.2 Charging Data Request message

Table 6.1.1.2.1 illustrates the basic structure of a Charging Data Request message from the SMF as used for 5G data connectivity converged charging.

**Table 6.1.1.2.1: Charging Data Request message contents**

Information Element	Category for converged charging	Category for offline only charging	Description
Session Identifier	O <sub>C</sub>	O <sub>C</sub>	Described in TS 32.290 [57]
Subscriber Identifier	O <sub>M</sub>	M	Described in TS 32.290 [57] In case SUPI is not present (for emergency service), the User Equipment Info in table 6.2.1.2.1. shall be present for identifying the user.
NF Consumer Identification	M	M	Described in TS 32.290 [57]
NF Functionality	M	O <sub>C</sub>	Described in TS 32.290 [57]
NF Name	O <sub>C</sub>	O <sub>C</sub>	Described in TS 32.290 [57]
NF Address	O <sub>C</sub>	O <sub>C</sub>	Described in TS 32.290 [57]
NF PLMN ID	O <sub>C</sub>	O <sub>C</sub>	Described in TS 32.290 [57]
Invocation Timestamp	M	M	Described in TS 32.290 [57]
Invocation Sequence Number	M	M	Described in TS 32.290 [57]
Retransmission Indicator	O <sub>C</sub>	O <sub>C</sub>	Described in TS 32.290 [57]
Notify URI	O <sub>C</sub>	O <sub>C</sub>	Described in TS 32.290 [57]
Service Specification Information	O <sub>C</sub>	O <sub>C</sub>	Described in TS 32.290 [57]
Supported Features	O <sub>C</sub>	-	This field indicates the features supported by the NF consumer.
Triggers	O <sub>C</sub>	O <sub>C</sub>	This field is described in TS 32.290 [57] and holds the 5G data connectivity specific triggers described in clause 5.2.1.
Multiple Unit Usage	O <sub>C</sub>	O <sub>C</sub>	Described in TS 32.290 [57] This field is not applicable to QBC.
Rating Group	M	M	Described in TS 32.290 [57]
Requested Unit	O <sub>C</sub>	-	Described in TS 32.290 [57]
Used Unit Container	O <sub>C</sub>	O <sub>C</sub>	Described in TS 32.290 [57]
Triggers	O <sub>C</sub>	O <sub>C</sub>	This field is described in TS 32.290 [57] and holds the 5G data connectivity specific triggers described in clause 5.2.1.
PDU Container Information	O <sub>C</sub>	O <sub>C</sub>	This field holds the 5G data connectivity PDU session container specific information described in clause 6.2.
UPF ID	O <sub>C</sub>	O <sub>C</sub>	This field holds the UPF identifier used to identify the UPF. These fields shall only be included when either quota is requested per UPF, or used units are reported per UPF
multi-homed PDU address	O <sub>C</sub>	O <sub>C</sub>	This field holds the IPv6 prefix used by UPF. It may only be used for IPv6 multi-homed PDU sessions and then only for reporting used units.
PDU Session Charging Information	O <sub>M</sub>	O <sub>M</sub>	This field holds the 5G data connectivity specific information described in clause 6.2. This field is applicable to FBC and QBC.
Roaming QBC information	O <sub>M</sub>	O <sub>M</sub>	This field holds the roaming QBC specific information defined in clause 6.2.1.4 This field is only applicable to QBC.

### 6.1.1.3 Charging data response message

Table 6.1.1.3.1 illustrates the basic structure of a Charging Data Response message from the CHF as used for 5G data connectivity converged charging.

**Table 6.1.1.3.1: Charging Data Response message contents**

Information Element	Category for converged charging	Category for offline only charging	Description
Session Identifier	O <sub>c</sub>	O <sub>c</sub>	Described in TS 32.290 [57]
Invocation Timestamp	M	M	Described in TS 32.290 [57]
Invocation Result	O <sub>c</sub>	M	Described in TS 32.290 [57]
Invocation Result Code	O <sub>c</sub>	M	Described in TS 32.290 [57]
Failed Parameter	O <sub>c</sub>	O <sub>c</sub>	Described in TS 32.290 [57]
Failure Handling	O <sub>c</sub>	O <sub>c</sub>	Described in TS 32.290 [57]
Invocation Sequence Number	M	M	Described in TS 32.290 [57]
Session Failover	O <sub>c</sub>	O <sub>c</sub>	Described in TS 32.290 [57]
Supported Features	O <sub>c</sub>	-	This field indicates the features supported by the NF consumer.
Multiple Unit Information	O <sub>c</sub>	O <sub>c</sub>	Described in TS 32.290 [57] This field is not applicable to QBC.
Result Code	O <sub>c</sub>	O <sub>c</sub>	Described in TS 32.290 [57]
Rating Group	M	M	Described in TS 32.290 [57]
UPF ID	O <sub>c</sub>	O <sub>c</sub>	This field holds the UPF identifier used for quota granted per UPF by CHF
Granted Unit	O <sub>c</sub>	-	Described in TS 32.290 [57]
Validity Time	O <sub>c</sub>	-	Described in TS 32.290 [57]
Final Unit Indication	O <sub>c</sub>	-	Described in TS 32.290 [57]
Time Quota Threshold	O <sub>c</sub>	-	Described in TS 32.290 [57]
Volume Quota Threshold	O <sub>c</sub>	-	Described in TS 32.290 [57]
Unit Quota Threshold	O <sub>c</sub>	-	Described in TS 32.290 [57]
Quota Holding Time	O <sub>c</sub>	-	Described in TS 32.290 [57]
Triggers	O <sub>c</sub>	O <sub>c</sub>	This field is described in TS 32.290 [57] and holds the 5G data connectivity specific triggers described in clause 5.2.1.
Triggers	O <sub>c</sub>	O <sub>c</sub>	This field is described in TS 32.290 [57] and holds the 5G data connectivity specific triggers described in clause 5.2.1.
PDU Session Charging Information	O <sub>M</sub>	O <sub>M</sub>	This field holds the 5G data connectivity specific information described in clause 6.2.
Roaming QBC Information	O <sub>M</sub>	O <sub>M</sub>	This field holds the roaming QBC specific information defined in clause 6.2.1.4 This field is not applicable to FBC.

### 6.1.2 Ga message contents

### 6.1.3 CDR description on the B<sub>d</sub> interface

#### 6.1.3.1 General

This clause describes the CDR content and format generated for 5G data connectivity - PDU session charging.

The following tables provide a brief description of each CDR parameter. The category in the tables is used according to the charging data configuration defined in clause 5.4 of TS 32.240 [1]. Full definitions of the CDR parameters, sorted by the name in alphabetical order, are provided in TS 32.298 [51].

#### 6.1.3.2 PDU session charging CHF CDR data

If enabled, CHF CDRs for PDU session charging shall be produced for each PDU session. In roaming Home routed scenario, the PDU session charging CHF CDR shall cover both Flow based Charging and Qos flow Based Charging (QBC) from H-SMF.

The fields of PDU session charging CHF CDR are specified in table 6.1.3.2.1.

Table 6.1.3.2.1: PDU session charging CHF record data

Field	Category	Description
Record Type	M	CHF record.
Recording Network Function ID	O <sub>M</sub>	This field holds the name of the recording entity, i.e. the CHF id.
Subscriber Identifier	O <sub>M</sub>	This field holds the Subscription Permanent Identifier (SUPI) of the served party. This fields should be present except for emergency session. The detail of SUPI is specified in clause 5.9.2 of TS 23.501 [200]
NF Consumer Information	M	This field holds the information of the SMF that used the charging service.
NF Functionality	M	This field contains the function of the node (i.e. SMF)
NF Name	O <sub>C</sub>	This field holds the name of the SMF used.
NF Address	O <sub>C</sub>	This fields holds the IP Address of the SMF used.
NF PLMN ID	O <sub>C</sub>	This field holds the PLMN identifier (MCC MNC) of the SMF.
List of Multiple Unit Usage	O <sub>M</sub>	This field holds a list of changes in charging conditions for all service data flows within this PDU session. This list is categorized per rating group or per combination of rating group and service id or per combination of rating group, sponsor identity and application service provider identity. In addition, usage is differentiated between with and without quota management. Each change is time stamped. Charging conditions are used to categorize traffic volumes, elapsed time and number of events, such as per tariff period.
Rating Group	O <sub>M</sub>	This filed holds the rating group.
Used Unit Container	O <sub>C</sub>	This field holds the used units and information connected to the reported units.
Service Identifier	O <sub>C</sub>	This field holds the Service Identifier.
Quota management Indicator	O <sub>M</sub>	This field holds an indicator on whether the used units are with or without quota management.
Triggers	O <sub>C</sub>	This field holds the reason for closing the used unit container.
Trigger Timestamp	O <sub>C</sub>	This field holds the timestamp of the trigger.
Time	O <sub>C</sub>	This field holds the amount of used time.
Total Volume	O <sub>C</sub>	This field holds the amount of used volume in both uplink and downlink directions.
Uplink Volume	O <sub>C</sub>	This field holds the amount of used volume in uplink direction.
Downlink Volume	O <sub>C</sub>	This field holds the amount of used volume in downlink direction.
Service Specific Unit	O <sub>C</sub>	This field holds the amount of used service specific units.
Event Time Stamps	O <sub>C</sub>	This field holds the timestamps of the event reported in the Service Specific Units, if the reported units are event based.
Rating Indicator	O <sub>C</sub>	This field indicates if the units have been rated or not.
Local Sequence Number	M	This field holds the container sequence number.
PDU Container Information	O <sub>C</sub>	This field holds the 5G data connectivity specific information defined in clause 6.2.1.3.
UPF ID	O <sub>C</sub>	This field holds the UPF identifier used to identify the UPF when reporting the usage for the UPF.
Multi-homed PDU address	O <sub>C</sub>	This field holds the Multi-homed IPv6 prefix used by UPF, identified by the UPF ID. It may only be used for reporting used units.
Record Opening Time	M	Time stamp when the PDU session is activated in the SMF or record opening time on subsequent partial records.
Duration	M	This field holds the duration of this record.
Record Sequence Number	C	Partial record sequence number, only present in case of partial records.
Cause for Record Closing	M	The reason for the release of the record.
Diagnostics	O <sub>M</sub>	This field holds a more detailed reason for the release of the PDU session, when a single cause is applicable.
Local Record Sequence Number	O <sub>M</sub>	Consecutive record number created by the CDF. The number is allocated sequentially including all CDR types.
Record Extensions	O <sub>C</sub>	A set of network operator/manufacture specific extensions to the record. Conditioned upon the existence of an extension.
PDU Session Charging Information	O <sub>M</sub>	This field holds the 5G data connectivity specific information defined in clause 6.2.1.2.
Roaming QBC information	O <sub>C</sub>	This field holds the roaming QBC specific information defined in clause 6.2.1.4, when applicable.

### 6.1.3.3 Roaming QBC CHF CDR data

If enabled, CHF CDRs for Roaming QBC shall be produced in VPLMN for each PDU session established for an in-bound roamer. The fields of Roaming QBC CHF CDR are specified in table 6.1.3.3.1.

**Table 6.1.3.3.1: Roaming QBC CHF record data**

Field	Category	Description
Record Type	M	CHF record.
Recording Network Function ID	O <sub>M</sub>	This field holds the name of the recording entity, i.e. the CHF id.
Subscriber Identifier	M	This field holds the 5G Subscription Permanent Identifier (SUPI) of the served party, if available.
NF Information	O <sub>C</sub>	This field holds the information of the V-SMF that used the charging service.
NF Functionality	M	This field contains the function of the node.
NF Name	O <sub>C</sub>	This field holds the name of the V-SMF used.
NF Address	O <sub>C</sub>	This fields holds the IP Address of the V-SMF used.
NF PLMN ID	O <sub>C</sub>	This field holds the PLMN identifier (MCC MNC) of the V-SMF.
Record Opening Time	M	Time stamp when the PDU session is activated in the SMF or record opening time on subsequent partial records.
Duration	M	This field holds the duration of this record.
Record Sequence Number	C	Partial record sequence number, only present in case of partial records.
Cause for Record Closing	M	The reason for the release of the record.
Diagnostics	O <sub>M</sub>	This field holds a more detailed reason for the release of the PDU session, when a single cause is applicable.
Local Record Sequence Number	O <sub>M</sub>	Consecutive record number created by the CHF. The number is allocated sequentially including all CDR types.
Record Extensions	O <sub>C</sub>	A set of network operator/manufacture specific extensions to the record. Conditioned upon the existence of an extension.
PDU Session Charging Information	O <sub>M</sub>	This field holds the 5G data connectivity specific information defined in clause 6.2.1.2.
Roaming QBC Information	O <sub>M</sub>	This field holds the 5G data connectivity Roaming QBC specific information defined in clause 6.2.1.4

## 6.2 5G data connectivity charging specific parameters

### 6.2.1 Definition of 5G data connectivity charging information

#### 6.2.1.1 General

The Charging Information parameter used for 5G data connectivity charging is provided in the following sub-clauses.

## 6.2.1.2 Definition of PDU session charging information

PDU session specific charging information used for 5G data connectivity charging is provided within the PDU session charging Information.

The detailed structure of the PDU Session Charging Information can be found in table 6.2.1.2.1.

**Table 6.2.1.2.1: Structure of PDU Session Charging Information**

Information Element	Category	Description
Charging Id	O <sub>M</sub>	This field holds the Charging Identifier for PDU session. The value of Charging Id is the same as that of Home Provided Charging Id in V-SMF only in the home routed roaming scenario for EPS to 5GS interworking and inter-PLMN mobility from HPLMN with I-SMF to VPLMN.
Home Provided Charging Id	O <sub>C</sub>	This field holds the Charging Identifier generated by H-SMF. This field is only applicable in V-SMF in the home routed roaming scenario for EPS to 5GS interworking and inter-PLMN mobility from HPLMN with I-SMF to VPLMN.
SMF Charging Id	O <sub>M</sub>	This field holds a string that, be provided from the SMF instead of Charging Id, if supported.
SMF Home Provided Charging Id	O <sub>M</sub>	This field holds a string that, be provided from the H-SMF instead of Home Provided Charging Id, if supported.
User Information	O <sub>M</sub>	Group of user information.
User Identifier	O <sub>C</sub>	This field contains the identification of the user (i.e. GPSI).
User Equipment Info	O <sub>C</sub>	This field holds the identification of the terminal (i.e. PEI, MAC Address) It is used for identifying the user in case SUPI is not present during emergency service. The detail identification of the wireline access is specified in clause 4.7.7 of TS 23.316 [203].
unauthenticatedFlag	O <sub>C</sub>	This field indicates the served SUPI is not authenticated.
Roamer In Out	O <sub>C</sub>	This field holds an indication if the roamer is in-bound or out-bound. This field is present only if UE is identified as a roamer.
User Location Info	O <sub>C</sub>	This field indicates details of where the UE is currently located (access-specific user location information). For MA PDU session, this field holds the user location associated to the 3GPP access
MA PDU Non 3GPP User Location info	O <sub>C</sub>	This field holds the user location associated to the non 3GPP access for MA PDU session.
User Location Time	O <sub>C</sub>	This field holds the UTC time at which the UE was last known to be in the location. For MA PDU session, this field holds the user location time associated to the 3GPP access.
MA PDU Non 3GPP User Location Time	O <sub>C</sub>	This field holds the user location time associated to the non 3GPP access for MA PDU session.
UE Time Zone	O <sub>C</sub>	This field holds the Time Zone of where the UE is located, if available where the UE currently resides.
Presence Reporting Area Information	O <sub>C</sub>	This field contains part of the Presence Reporting Area Information of UE as defined in TS 23.501[200], comprising the Presence Reporting Area identifier(s) and an indication on whether the UE is inside or outside the Presence Reporting Area, if available.
PDU Session Information	O <sub>C</sub>	Group of PDU session information.
PDU Session ID	M	This field holds identifier of PDU session.
Network Slice Instance Identifier	O <sub>M</sub>	This field holds network slice information the PDU session belongs to.
PDU Type	O <sub>M</sub>	This field holds the type of PDU session.
PDU Address	O <sub>C</sub>	Group of UE IP address.
PDU Ipv4 Address	O <sub>C</sub>	This field holds the IP Address of the served SUPI allocated for PDU session, i.e. IPv4 address.
PDU IPv6 Address with Prefix	O <sub>C</sub>	This field holds the IP Address of the served SUPI allocated for PDU session, i.e. IPv6 prefix.
PDU Address prefix length	O <sub>C</sub>	PDP/PDN Address prefix length of an IPv6 typed Served PDU Address. The field needs not available for prefix length of 64 bits.
IPv4 Dynamic Address Flag	O <sub>C</sub>	This field indicates whether served PDP/PDN address for IPv4 is dynamically allocated. This field is missing if address is static.
IPv6 Dynamic Address Flag	O <sub>C</sub>	This field indicates whether served PDP/PDN address for IPv6 is dynamically allocated. This field is missing if address is static.
Additional PDU IPv6 prefixes	O <sub>C</sub>	This field holds a list of additional IPv6 prefix allocated for the PDU session, when applicable.
SSC Mode	O <sub>C</sub>	This field holds SSC mode of PDU session.
MA PDU session information	O <sub>C</sub>	This field holds information associated to the MA PDU session.
MA PDU session indicator	O <sub>C</sub>	This field indicates the PDU session is a MA PDU session requested by the UE or requested by Network modification based ATSSS capabilities provided by the UE and the Network.

ATSSS capability	O <sub>c</sub>	This field holds the ATSSS capability supported by the MA PDU session
SUPI PLMN ID	O <sub>c</sub>	This field holds PLMN ID of the SUPI.
CP Clot Optimisation indicator	O <sub>c</sub>	This field holds the indicator whether control plane optimization Clot for 5GS is used during the PDU session, if this feature is enabled.
5GS Control Plane Only indicator	O <sub>c</sub>	This field holds the indicator whether the control plane only is used, i.e., the PDU data only transfers to control plane in case of control plane Clot optimization.
Small data rate control indicator	O <sub>c</sub>	This field holds the indicator whether the small data rate control for 5GS Clot is used during the PDU session.
Serving Network Function ID	O <sub>c</sub>	This field holds the identity of the serving network function <ul style="list-style-type: none"> <li>- AMF identity for the PDU sessions being served by SMF in non-roaming</li> <li>- V-SMF identity for the home routed roaming</li> <li>- I-SMF identity for PDU session being served by SMF + I-SMF</li> <li>- ePDG identity for handover between EPC/ePDG and 5GS</li> <li>- SGW identity for the EPC/E-UTRAN interworking</li> </ul> In all other cases the identity is implementation specific.
Serving Network Function Functionality	M	This field holds the functionality of the serving network function: <ul style="list-style-type: none"> <li>- AMF for the PDU sessions being served by SMF in non-roaming</li> <li>- SMF for the home routed roaming</li> <li>- I-SMF for the PDU session being served by SMF + I-SMF</li> <li>- ePDG for handover between EPC/ePDG and 5GS</li> <li>- SGW for EPC/E-UTRAN interworking.</li> </ul>
Serving Network Function Name	O <sub>c</sub>	This field holds the unique identifier of the serving network function instance.
Serving Network Function Addresses	O <sub>c</sub>	This field holds the IP addresses of the serving network function.
Serving Network Function FQDN	O <sub>c</sub>	This field holds the FQDN the serving network function. When the serving network function is an AMF, this FQDN is the AMF name as defined in clause 5.9.5 of 3GPP TS 23.501 [200].
Serving Network Function PLMN ID	O <sub>c</sub>	This field holds the PLMN ID of the network the Serving Network Function belongs to.
AMF Identifier	O <sub>c</sub>	This field holds the AMF identifier.
Serving CN PLMN ID	O <sub>c</sub>	This field holds the serving Core Network Operator PLMN ID selected by the UE if different from SMF PLMN ID.
RAT Type	O <sub>c</sub>	This field holds the Radio Access Technology (RAT) currently serving the UE. For MA PDU session, this field holds the Radio Access Technology (RAT) associated to the 3GPP access
MA PDU Non 3GPP RAT Type	O <sub>c</sub>	This field holds the Radio Access Technology (RAT) serving the UE in non 3GPP access for MA PDU session.
Data Network Name Identifier	M	This field contains the identifier of the DNN the user is connected to.
DNN Selection Mode	O <sub>c</sub>	This field indicates whether the requested DNN corresponds to an explicitly subscribed DNN or to the usage of a wildcard subscription.
Authorized QoS Information	O <sub>c</sub>	This field holds the authorized QoS applied to PDU session.
Subscribed QoS Information	O <sub>c</sub>	This field holds the subscribed default QoS for the PDU session.
Authorized Session-AMBR	O <sub>c</sub>	This field holds the authorized Session-AMBR for the PDU session.
Subscribed Session-AMBR	O <sub>c</sub>	This field holds the subscribed Session-AMBR for the PDU session.
PDU session start Time	O <sub>c</sub>	This field holds the timestamp when PDU session starts.
PDU session stop Time	O <sub>c</sub>	This field holds the timestamp when PDU session terminates.
Diagnostics	O <sub>c</sub>	This field holds a detailed reason for the release of the PDU session and complements the "Change Condition" information.
Enhanced Diagnostics	O <sub>c</sub>	This field holds a more detailed reason for the release of the PDU session, when a set of causes are applicable.
Charging Characteristics	O <sub>c</sub>	This field holds the Charging Characteristics for this PDU session.
Charging Characteristics Selection Mode	O <sub>c</sub>	This field holds information about how the "Charging Characteristics" was selected.
3GPP PS Data Off Status	O <sub>c</sub>	This field holds the 3GPP Data off Status when UE's 3GPP Data Off status is Activated or Deactivated.
Session Stop Indicator	O <sub>c</sub>	This field indicates to the CHF that the PDU session has been terminated.



Redundant Transmission Type	O <sub>c</sub>	This field holds the redundant transmission Type.
PDU Session Pair ID	O <sub>c</sub>	This field holds an identifier that may be used to link two redundant PDU Sessions for dual connectivity based end to end redundant user plane paths type.
5G LAN Type Service	O <sub>c</sub>	This field holds the 5G LAN Type service information, if present, the 5G LAN Type service is used.
Internal Group Identifier	M	This field holds the identifier of the 5G LAN VN group.
Unit Count Inactivity Timer	O <sub>c</sub>	This field holds the threshold for the time period when no units has been counted by the SMF. It holds either the value configured in SMF, if it is supported, or the value to be used as received from the CHF. A value of zero indicates that this mechanism shall not be used. This field is not applicable to QBC.
RAN Secondary RAT Usage Report	O <sub>c</sub>	This field holds the secondary RAT usage reported from NG-RAN.
NG RAN Secondary RAT Type	O <sub>c</sub>	This field holds the value of Secondary RAT Type, as provided by the NG-RAN.
Qos Flows Usage Reports	O <sub>c</sub>	This field holds a list of containers per QFI with volumes reported, each container is time stamped.
QoS Flow Id	O <sub>M</sub>	This field holds the QoS flow Identifier (QFI)
Start Timestamp	O <sub>c</sub>	This field holds the start timestamp of the collected usage.
End Timestamp	O <sub>c</sub>	This field holds the end timestamp of the collected usage.
Downlink Volume	O <sub>c</sub>	This field holds the amount of used volume in downlink direction.
Uplink Volume	O <sub>c</sub>	This field holds the amount of used volume in uplink direction.

### 6.2.1.3 Definition of PDU Container information

Used Unit Container, described in table 6.1.1.2.1, specific charging information used for 5G data connectivity charging is provided within the PDU Container Information described in table 6.2.1.3.1.

**Table 6.2.1.3.1: Structure of PDU Container Information**

Information Element	Category	Description
Time of First Usage	O <sub>c</sub>	This field holds the Timestamp when the first transmitted IP packet of the service data flow matching the current used unit container
Time of Last Usage	O <sub>c</sub>	This field holds the Timestamp when the last transmitted IP packet of the service data flow matching the current used unit container
QoS Information	O <sub>c</sub>	This field holds the QoS applied during the service data container interval
QoS Characteristics	O <sub>c</sub>	This field holds the QoS characteristics applied for QoS information. It is only be used when the non-standardized 5QI is present in QoS information.
AF Charging Identifier	O <sub>c</sub>	A Charging Identifier, provided from the AF, may be used to correlate the measurement for the Charging key/Service identifier values in this PCC rule with application level reports.
AF Charging Id String	O <sub>c</sub>	A string that, may be provided from the AF instead of AF Charging Identifier, depending on support.
User Location Information	O <sub>c</sub>	This field holds the user location during the used unit container interval
UE Time Zone	O <sub>c</sub>	This field holds the Time Zone of where the UE is located, during the used unit container interval.
Presence Reporting Area Information	O <sub>c</sub>	This field holds the Presence Reporting Area Information of UE during the used unit container interval.
Serving Network Function ID	O <sub>c</sub>	Serving Network Function identifier.
RAT Type	O <sub>c</sub>	This field holds the RAT type during the used unit container interval. For MA PDU session, this field holds the RAT type associated to the access which activated the rating group.
Sponsor Identity	O <sub>c</sub>	This field holds the identifier of the sponsor when sponsored data connectivity is used

Information Element	Category	Description
Application Service Provider Identity	O <sub>c</sub>	This field holds the identifier of the application service provider that is delivering a service to the end user.
Charging Rule Base Name	O <sub>c</sub>	This field holds the reference to group of PCC rules predefined at the SMF
3GPP PS Data Off Status	O <sub>c</sub>	This field holds the 3GPP Data off Status during the used unit container interval
MA PDU Steering functionality	O <sub>c</sub>	This field holds the Steering functionality used during the used unit container interval when MA PDU session
MA PDU Steering mode	O <sub>c</sub>	This field holds the Steering mode used during the used unit container interval when MA PDU session.
Traffic Forwarding Way	O <sub>c</sub>	This field holds the traffic forwarding way for the 5G VN group communication if present. If the SMF can distinguish the traffic forwarding way, the SMF reports the volume per traffic forwarding way. If the SMF cannot distinguish, the SMF reports the traffic and the corresponding traffic forwarding way (may be multiple).
QoS Monitoring Report	O <sub>c</sub>	This field holds the QoS monitoring result (i.e., average packet delay per QoS flow per UE) for the service data flow.

#### 6.2.1.4 Definition of roaming QBC information

Roaming QBC specific charging information used for 5G data connectivity charging is provided within the Roaming QBC Information.

The detailed structure of the Roaming QBC Information can be found in table 6.2.1.4.1.

**Table 6.2.1.4.1: Structure of Roaming QBC Information**

Information Element	Category	Description
Multiple QFI container	O <sub>c</sub>	This field holds a list of QFI containers. It may have multiple occurrences
Triggers	O <sub>c</sub>	This field holds the reason for closing the QFI unit container.
Trigger Timestamp	O <sub>c</sub>	This field holds the timestamp of the trigger.
Time	O <sub>c</sub>	This field holds the amount of used time.
Total Volume	O <sub>c</sub>	This field holds the amount of used volume in both uplink and downlink directions.
Uplink Volume	O <sub>c</sub>	This field holds the amount of used volume in uplink direction.
Downlink Volume	O <sub>c</sub>	This field holds the amount of used volume in downlink direction.
Local Sequence Number	M	This field holds a QFI data container sequence number
QFI Container information	O <sub>c</sub>	This field holds the QFI data container information defined in clause 6.2.1.5
UPF ID	O <sub>c</sub>	This field holds the UPF identifier and is included for backwards compatibility. It can be included when reporting the usage for the UPF, depending on operator requirement.
Roaming Charging Profile	O <sub>c</sub>	This field holds the Roaming Charging Profile associated to the PDU session for roaming QBC.
Trigger	O <sub>c</sub>	This field holds the trigger applicable to QBC. This field has multiple occurrences
Trigger type	O <sub>c</sub>	This field holds the chargeable events defined in table 5.2.1.6.1.
Trigger category	O <sub>c</sub>	This field holds the trigger category (i.e. immediate or deferred reporting)
Time Limit	O <sub>c</sub>	This field holds the limit value in seconds when the trigger type is "Expiry of data time limit"
Volume Limit	O <sub>c</sub>	This field holds the limit value in octets when the trigger type is "Expiry of data volume limit"
Max Number of charging condition changes	O <sub>c</sub>	This field holds the limit value when the trigger type is "Expiry of limit of number of charging condition changes"
Partial record method	O <sub>c</sub>	This field holds the method uses by the CHF for partial record closure: default or Individual.

#### 6.2.1.5 Definition of QFI Container information

QFI Container information, defined in table 6.2.1.4.1, specific charging information used for 5G data connectivity QBC charging is provided within the QFI Container Information described in table 6.2.1.5.1.

**Table 6.2.1.5.1: Structure of QFI Container Information**

Information Element	Category	Description
QoS Flow Id	M	This field holds the QoS flow Identifier (QFI)
Time of First Usage	O <sub>c</sub>	This field holds the Timestamp when the first transmitted IP packet of the service data flow matching the current QFI data container
Time of Last Usage	O <sub>c</sub>	This field holds the Timestamp when the last transmitted IP packet of the service data flow matching the current QFI data container
QoS Information	O <sub>c</sub>	This field holds the QoS applied during the QFI data container interval
QoS Characteristics	O <sub>c</sub>	This field holds the QoS characteristics applied for QoS information. It is only be used when the non-standardized 5QI is present in QoS information.

Information Element	Category	Description
User Location Information	O <sub>C</sub>	This field holds the user location during the QFI data container interval
UE Time Zone	O <sub>C</sub>	This field holds the Time Zone of where the UE is located, during the QFI data container interval
RAT Type	O <sub>C</sub>	This field holds the RAT type during the QFI data container interval
Report Time	M	This field holds the Timestamp when the QFI data container was closed
Serving Network Function ID	O <sub>C</sub>	Group of serving Network Function identifier.
3GPP PS Data Off Status	O <sub>C</sub>	This field holds the 3GPP Data off Status during the QFI data container interval

## 6.2.2 Detailed message format for converged charging

The following clause specifies per Operation Type the charging data that are sent by SMF for 5G data connectivity converged charging or offline only charging.

The Operation Types are listed in the following order: I (Initial)/U (Update)/T (Termination)/E (Event). Therefore, when all Operation Types are possible it is marked as IUTE. If only some Operation Types are allowed for a node, only the appropriate letters are used (i.e. IUT or E) as indicated in the table heading. The omission of an Operation Type for a particular field is marked with "-" (i.e. IU-E). Also, when an entire field is not allowed in a node the entire cell is marked as "-".

Table 6.2.2.1 defines the basic structure of the supported fields in the *Charging Data Request* message for 5G data connectivity converged charging or offline only charging.

**Table 6.2.2.1: Supported fields in *Charging Data Request* message**

Information Element	Functionality of SMF	FBC	QBC	FBC	QBC
	Charging Service	Converged Charging	Converged Charging	Offline Only Charging	Offline Only Charging
	Supported Operation Types	I/U/T/E	I/U/T/E	I/U/T/E	I/U/T/E
Session Identifier		-UT-	-UT-	-UT-	-UT-
Subscriber Identifier		IUT-	IUT-	IUT-	IUT-
NF Consumer Identification		IUT-	IUT-	IUT-	IUT-
Invocation Timestamp		IUT-	IUT-	IUT-	IUT-
Invocation Sequence Number		IUT-	IUT-	IUT-	IUT-
Retransmission Indicator		IUT-	IUT-	IUT-	IUT-
Notify URI		IU-	IU-	IU-	IU-
Supported Features		IU-	IU-	-	-
Service Specification Information		IUT-	IUT-	IUT-	IUT-
Triggers		-UT-	-UT-	-UT-	-UT-
Multiple Unit Usage		IUT-	-	IUT-	-
Rating Group		IUT-	-	IUT-	-
Requested Unit		IU--	-	-	-
Used Unit Container		-UT-	-	-UT-	-
Triggers		-UT-	-	-UT-	-
PDU Container Information		-UT-	-	-UT-	-
UPF ID		IUT-	-	IUT-	-
PDU Session Charging Information		IUT-	IUT-	IUT-	IUT-
Charging Id		IUT-	IUT-	IUT-	IUT-
SMF Charging Id		IUT-	IUT-	IUT-	IUT-
Home Provided Charging Id		-UT-	-UT-	-UT-	-UT-
SMF Home Provided Charging Id		-UT-	-UT-	-UT-	-UT-
User Information		IUT-	IUT-	IUT-	IUT-
User Location Info		IUT-	IUT-	IUT-	IUT-
MA PDU Non 3GPP User Location Info		IUT-	IUT-	IUT-	IUT-
User Location Time		IUT-	IUT-	IUT-	IUT-
MA PDU Non 3GPP User Location Time		IUT-	IUT-	IUT-	IUT-
UE Time Zone		IUT-	IUT-	IUT-	IUT-
Presence Reporting Area Information		-UT-	-UT-	-UT-	-UT-
PDU Session Information		IUT-	IUT-	IUT-	IUT-
PDU Session ID		IUT-	IUT-	IUT-	IUT-
Network Slice Instance Identifier		IUT-	IUT-	IUT-	IUT-
PDU Type		IUT-	IUT-	IUT-	IUT-
PDU Address		IUT-	IUT-	IUT-	IUT-
SSC Mode		IUT-	IUT-	IUT-	IUT-
MA PDU session information		IUT-	IUT-	IUT-	IUT-
SUPI PLMN ID		IUT-	IUT-	IUT-	IUT-
Serving Network Function ID		IUT-	IUT-	IUT-	IUT-
Serving CN PLMN ID		IUT-	IUT-	IUT-	IUT-
RAT Type		IUT-	IUT-	IUT-	IUT-
MA PDU Non 3GPP RAT Type		IUT-	IUT-	IUT-	IUT-
Data Network Name Identifier		IUT-	IUT-	IUT-	IUT-
DNN Selection Mode		IUT-	IUT-	IUT-	IUT-
Authorized QoS Information		IUT-	IUT-	IUT-	IUT-
Subscribed QoS Information		IUT-	IUT-	IUT-	IUT-
Authorized Session-AMBR		IUT-	IUT-	IUT-	IUT-
Subscribed Session-AMBR		IUT-	IUT-	IUT-	IUT-
PDU session start Time		I---	I---	I---	I---
PDU session stop Time		--T-	--T-	--T-	--T-
Diagnostics		--T-	--T-	--T-	--T-
Enhanced Diagnostics		--T-	--T-	--T-	--T-
Charging Characteristics		IUT-	IUT-	IUT-	IUT-
Charging Characteristics Selection Mode		IUT-	IUT-	IUT-	IUT-
3GPP PS Data Off Status		IUT-	IUT-	IUT-	IUT-
Session Stop Indicator		--T-	--T-	--T-	--T-
Redundant Transmission Type		IUT-	IUT-	IUT-	IUT-
PDU Session Pair ID		IUT-	IUT-	IUT-	IUT-
5G LAN Type Service		IUT-	IUT-	IUT-	IUT-
Unit Count Inactivity Timer		IU--	-	IU--	-
RAN Secondary RAT Usage Report		-UT-	-UT-	-UT-	-UT-

Roaming QBC information	-	IUT-	-	IUT-
Multiple QFI container	-	IUT-	-	IUT-
UPF ID	-	IUT-	-	IUT-
Roaming Charging Profile	-	IU--	-	IU--

Table 6.2.2.2 defines the basic structure of the supported fields in the *Charging Data* Response message for 5G data connectivity converged charging or offline only charging.

**Table 6.2.2.2: Supported fields in *Charging Data* Response message**



Information Element	Functionality of SMF	FBC	QBC	FBC	QBC
	Charging Service	Converged Charging	Converged Charging	Offline Only Charging	Offline Only Charging
	Supported Operation Types	I/U/T/E	I/U/T/E	I/U/T/E	I/U/T/E
Session Identifier		I---	I---	I---	I---
Invocation Timestamp		IUT-	IUT-	IUT-	IUT-
Invocation Result		IUT-	IUT-	IUT-	IUT-
Invocation Sequence Number		IUT-	IUT-	IUT-	IUT-
Session Failover		IU--	IUT-	IU--	IUT-
Supported Features		IU--	IU--	-	-
Triggers		IU--	IU--	IU--	IU--
Multiple Unit information		IU--	-	IU--	-
Result Code		IU--	-	IU--	-
Rating Group		IU--	-	IU--	-
UPF ID		IU--	-	IU--	-
Granted Unit		IU--	-	-	-
Validity Time		IU--	-	-	-
Final Unit Indication		IU--	-	-	-
Time Quota Threshold		IU--	-	-	-
Volume Quota Threshold		IU--	-	-	-
Unit Quota Threshold		IU--	-	-	-
Quota Holding Time		IU--	-	-	-
Triggers		IU--	-	IU--	-
PDU Session Charging Information		IU--	IU--	IU--	IU--
Charging Id		-	-	-	-
SMF Charging Id		-	-	-	-
Home Provided Charging Id		-	-	-	-
SMF Home Provided Charging Id		-	-	-	-
User Information		-	-	-	-
User Location Info		-	-	-	-
MA PDU Non 3GPP User Location info		-	-	-	-
User Location Time		-	-	-	-
MA PDU Non 3GPP User Location Time		-	-	-	-
UE Time Zone		-	-	-	-
Presence Reporting Area Information		IU--	IU--	IU--	IU--
PDU Session Information		-	-	-	-
PDU Session ID		-	-	-	-
Network Slice Instance Identifier		-	-	-	-
PDU Type		-	-	-	-
PDU Address		-	-	-	-
SSC Mode		-	-	-	-
MA PDU session information		-	-	-	-
SUPI PLMN ID		-	-	-	-
Serving Network Function ID		-	-	-	-
Serving CN PLMN ID		-	-	-	-
RAT Type		-	-	-	-
MA PDU Non 3GPP RAT Type		-	-	-	-
Data Network Name Identifier		-	-	-	-
DNN Selection Mode		-	-	-	-
Authorized QoS Information		-	-	-	-
Subscribed QoS Information		-	-	-	-
Authorized Session-AMBR		-	-	-	-
Subscribed Session-AMBR		-	-	-	-
PDU session start Time		-	-	-	-
PDU session stop Time		-	-	-	-
Diagnostics		-	-	-	-
Enhanced Diagnostics		-	-	-	-
Charging Characteristics		-	-	-	-
Charging Characteristics Selection Mode		-	-	-	-
3GPP PS Data Off Status		-	-	-	-
Session Stop Indicator		-	-	-	-
Redundant Transmission Type		-	-	-	-

PDU Session Pair ID	-	-	-	-
5G LAN Type Service	-	-	-	-
Unit Count Inactivity Timer	IU--	-	-	-
RAN Secondary RAT Usage Report	-	-	-	-
Roaming QBC information	-	IU--	-	IU--
Multiple QFI container	-	-	-	-
UPF ID	-	-	-	-
Roaming Charging Profile	-	IU--	-	IU--

## 6.2.3 Formal 5G data connectivity charging parameter description

### 6.2.3.1 5G data connectivity CHF CDR parameters

The detailed definitions, abstract syntax and encoding of the PDU session charging and Roaming QBC CHF CDRs parameters are specified in TS 32.298 [51].

### 6.2.3.2 5G data connectivity resources attributes

The detailed definitions of resources attributes used for 5G data connectivity charging are specified in TS 32.291 [58].

# Annex A (normative): Charging Characteristics

## A.1 General

A subscriber may have Charging Characteristics assigned to his subscription and/or his subscribed DNNs. Default Charging Characteristics may also be pre-provisioned on the SMF.

During UE PDU session establishment, when the SMF retrieves subscription data from the UDM, if a subscribed Charging Characteristics for the requested DNN is identified, it may override the SMF pre-provisioned Charging Characteristics.

The Charging Characteristics parameter consists of a string of 16 bits designated as Behaviours (B), freely defined by Operators, as shown in TS 32.298 [51]. Each bit corresponds to a specific charging behaviour which is configured on a per operator basis, and pointed when bit is set to "1" value.

A charging behaviour is defined as an association to a specific usage design:

One usage may consist of a set of trigger profiles associated to the PDU session in converged charging as described in the Table A.1 example:

**Table A.1: Example of Charging Characteristics behaviours for SMF**

Behaviour index	PDU session charging									
	Default charging method	PDU session charging method	Charging service	Primary and Secondary CHF addresses	Active	Time Limit Per PDU session	Vol Limit Per PDU session	Change Cond. Per PDU session	Tariff times	...
0	Online	-	Converged charging	URI 1 URI 2	Yes	10 min	1Mb	2	0-7, 7-12	...
1	Offline	-	Converged charging	URI 1 URI 2	Yes	15 min	5Mb	3	0-24	...
2	Online	-	Converged charging	URI 1 URI 2	Yes	30 min	2Mb	2	0-7, 7-12	...
3		Offline only	Offline only charging	URI 1 URI 2	Yes	15 min	1MB	-1	-0-24	...
4	-	Offline only	Converged charging	URI 1 URI 2	No	15 min	1MB	1	0-24	...
...	...			...	...	...	...	...	...	...

Associated to the behaviour, the following may also be configured:

- the CHF addresses to be used by the SMF, optionally with associated CHF instance ID(s) and/or CHF set ID(s);
- the "Default charging method" (online or offline) to be used as the default one for every PCC rules of the PDU Session;
- the PDU session charging method indicating whether the charging method for the PDU session is "offline only".
- charging service.

The "Default charging method", PDU session charging method and CHF addresses with possible associated CHF instance ID(s) and/or CHF set ID(s) configured in the applicable Charging Characteristics behaviour, are superseded by "Default charging method", PDU session charging method and CHF addresses with possible associated CHF instance ID(s) and/or CHF set ID(s) supplied by the PCF if any, during SMF interaction with the PCF at PDU session establishment, as described in TS 23.503 [202].

## Annex B (normative): Interworking

### B.1 General

This clause specifies the EPS and 5GS interworking.

### B.2 Definition of charging information for interworking

#### B.2.1 Data description for interworking with EPC

##### B.2.1.1 Message contents

The Charging message as described in clause 6.1.1 shall apply to the PGW-C+SMF for interworking with EPC scenario.

When UE is connected to PGW-C+SMF via EPC and interworking with 5GS is supported, the information and mechanism included in clause 6.1.1 and TS 32.290[57] is supported.

##### B.2.1.2 Ga message contents

##### B.2.1.3 CDR description on the Bd interface

The CDR description defined in clause 6.1.3.2 with Roaming QBC information per clause B.2.2.1.1 is used for interworking with EPC scenario.

### B.2.2 Interworking charging specific parameters

#### B.2.2.1 Definition of Interworking charging information

##### B.2.2.1.1 Message content

The charging information defined in clause 6.2.1 is used for interworking with EPC scenario.

The specific information used for PS charging when UE is connected to P-GW+SMF via EPC is provided within the Charging Data Request message, as defined in clause 6.1.1.2, with the following difference:

**Table B.2.2.1.1-1: Charging Data Request message contents**

Information Element	Category	Description
Roaming QBC information	Oc	This field holds the QBC information specific to 5GC interworking with EPC as defined in clause B.2.2.1.2. This field is applicable in both non-roaming and roaming Home Routed scenario.

##### B.2.2.1.2 Roaming QBC information

Roaming QBC information specific to 5GC interworking with EPC when UE is connected to P-GW+SMF via EPC is defined in table B.2.2.1.1-1:

**Table B.2.2.1.2-1: Roaming QBC information**

Information Element	Category	Description
MultipleQFIcontainer	O <sub>C</sub>	This field holds the containers associated to a charging condition change on an IP-CAN bearer. This is included when triggers conditions are met (Qos change, tariff time change ...). It may have multiple occurrences. This field is applicable for both non-roaming and roaming Home Routed scenario
Triggers	O <sub>C</sub>	Described in table 6.2.1.4.1
Trigger Timestamp	O <sub>C</sub>	Described in table 6.2.1.4.1
Uplink Volume	O <sub>C</sub>	Described in table 6.2.1.4.1
Downlink Volume	O <sub>C</sub>	Described in table 6.2.1.4.1
Local Sequence Number	O <sub>C</sub>	Described in table 6.2.1.4.1
QFI Container information	O <sub>C</sub>	This field holds the data container information defined in clause B.2.2.1.3

### B.2.2.1.3 QFI Container Information

QFI Container Information specific to 5GC interworking with EPC when UE is connected to P-GW+SMF via EPC is defined in table B.2.2.1.3-1:

**Table B.2.2.1.3-1: QFI Container Information**

Information Element	Category	Description
QoS Information	O <sub>C</sub>	Described in table 6.2.1.5.1
QoS Characteristics	O <sub>C</sub>	Described in table 6.2.1.5.1
User Location Information	O <sub>C</sub>	Described in table 6.2.1.5.1
Presence Reporting Area Information	O <sub>C</sub>	Described in table 6.2.1.5.1
RAT Type	O <sub>C</sub>	Described in table 6.2.1.5.1
Report Time	M	Described in table 6.2.1.5.1
3GPP PS Data Off Status	O <sub>C</sub>	Described in table 6.2.1.5.1
EPS bearer Charging Id	O <sub>M</sub>	This field holds the Charging Identifier associated to the bearer the QoS flow is mapped to.
Diagnostics	O <sub>M</sub>	This field holds a more detailed reason for the release of the IP-CAN bearer, when a single cause is applicable.
Enhanced Diagnostics	O <sub>C</sub>	This field holds a more detailed reason for the release of the IP-CAN bearer, when a set of causes is applicable.

### B.2.2.2 Detailed message format for Interworking charging

The message format defined in clause 6.2.2 is used for interworking with EPC scenario.

The supported fields in table 6.2.2.1 for the converged charging message shall apply to the P-GW+SMF for the applicable fields, with the difference that SMF is replaced by P-GW+SMF.

The table B.2.2.2-1 describes the mapping between the Multiple QFI Container Information Elements defined for interworking and Traffic data volumes CDR parameters defined in 32.298 [51] for EPC.

**Table B.2.2.2-1: MultipleQFI Container for Interworking mapping to EPC Traffic data volumes**

Information Element for 5G Data connectivity	Information Element for Interworking	Corresponding to 32.298 [51]
Multiple QFI Container	Yes	Traffic data volumes
Triggers	Yes	Change condition
Trigger Timestamp	Yes	Change Time
Time	No	-
Total Volume	No	-
Uplink Volume	Yes	Data Volume Uplink
Downlink Volume	Yes	Data Volume Downlink
Local Sequence Number	yes	-
QFI Container Information	Yes	-
QFI	No	-
Time of First Usage	No	-
Time of Last Usage	No	-
QoS Information	Yes	EPC QoS Information
User Location Information	Yes	User Location Information
UE Time Zone	No	-
Presence Reporting Area Information	Yes	Presence Reporting Area Status
RAT Type	Yes	RAT Type
Serving Network Function ID	No	-
3GPP PS Data Off Status	yes	3GPP PS Data Off Status
-	3GPP Charging Id	Charging Id
-	Enhanced Diagnostics	Enhanced Diagnostics
-	Diagnostics	Diagnostics
-	No	UWAN User Location Information
-	No	User CSG information
-	No	Access Availability Change Reason
-	No	Related Change of Charging Condition
-	No	CP CloT EPS optimisation indicator
-	No	Serving PLMN Rate Control

### B.2.2.3 Formal Interworking charging parameter description

The CHF CDR parameters and resources attributes defined in clause 6.2.3 is used for interworking with EPC scenario.

---

## Annex C (normative): Support of GERAN/UTRAN access

### C.1 General

This Annex specifies Nchf from SMF+PGW-C enhanced to support UE accessing the network via GERAN/UTRAN.

---

### C.2 5G data connectivity charging principles and scenarios

#### C.2.1 5G data connectivity charging principles

The 5G data connectivity charging principles as described in clause 5.1 shall apply with the differences that SMF is replaced by SMF+PGW-C supporting GERAN/UTRAN access, and only following clauses are applicable:

- Clauses 5.1.1 to 5.1.9 except 5.1.6 and 5.1.5.3;
- Clauses 5.1.11 to 5.1.12.

For GERAN/UTRAN access, the Charging Identifier of the PDU session will be generated by SMF+PGW-C for the PDP Context.

#### C.2.2 5G data connectivity converged online and offline charging scenarios

The 5G data connectivity converged online and offline charging scenarios as described in clause 5.2 shall apply with the differences that SMF is replaced by SMF+PGW-C supporting GERAN/UTRAN access, and only following clauses are applicable:

- Clauses 5.2.1.1 to 5.2.1.9 except 5.2.1.5;
- Clauses 5.2.2.1 to 5.2.2.2.

In Table 5.2.1.4.1 and Table 5.2.1.6.1, only trigger conditions related to GERAN/UTRAN access scenarios are applicable.

#### C.2.3 CDR generation and transfer

Clause 5.2.3 shall apply, with the difference in trigger tables where only triggers related to GERAN/UTRAN access scenarios are applicable.

Clauses 5.2.4 and 5.2.5 are applicable.

## C.3 Data description for 5G data connectivity charging

### C.3.1 Data description for support of GERAN/UTRAN access

#### C.3.1.1 Message contents

The charging message as described in clause 6.1.1 shall apply to the SMF+PGW-C to support GERAN/UTRAN access. The differences of charging message in clause 6.1.1 used for the SMF+PGW-C to support GERAN/UTRAN access are described as following.

- UPF ID is not applicable;
- Multi-homed PDU address is not applicable;
- PDU Session Charging Information is described in C.3.2.

#### C.3.1.2 Ga message contents

The Ga message transfer as described in clause 5.2.4 shall apply to the SMF+PGW-C to support GERAN/UTRAN access.

#### C.3.1.3 CDR description on the B<sub>d</sub> interface

The CDR description defined in clause 6.1.3 shall apply with the differences that SMF is replaced by SMF+PGW-C supporting GERAN/UTRAN access, and the following fields in table 6.1.3.2.1 are not applicable:

- UPF ID;
- Multi-homed PDU address.

## C.3.2 5G data connectivity charging specific parameters

### C.3.2.1 Definition of 5G data connectivity charging information

The charging information defined in clause 6.2.1 is used for the SMF+PGW-C to support GERAN/UTRAN access.

The specific PDU session charging information when UE is connected to SMF+P-GW-C via GERAN/UTRAN is provided as defined in table 6.2.1.2.1, with the differences that PDU session is replaced by PDP context in fields description and other differences described under following table C.3.2.1-1:

**Table C.3.2.1-1: Structure of PDU Session Charging Information**

Information Element	Category	Description
Charging Id	O <sub>M</sub>	Described in table 6.2.1.2.
Home Provided Charging Id	-	This field is not applicable.
User Information	O <sub>M</sub>	Described in table 6.2.1.2.
User Identifier	O <sub>C</sub>	Described in table 6.2.1.2.
User Equipment Info	O <sub>C</sub>	Described in table 6.2.1.2.
unauthenticatedFlag	O <sub>C</sub>	Described in table 6.2.1.2.
Roamer In Out	O <sub>C</sub>	Described in table 6.2.1.2.
User Location Info	O <sub>C</sub>	Described in table 6.2.1.2. The "User Location Information" (ULI) IE indicating CGI/SAI/RAI shall apply as described in clause 7.7.51 of TS 29.060 [x].
MA PDU Non 3GPP User Location info	-	This field is not applicable.
User Location Time	O <sub>C</sub>	Described in table 6.2.1.2.
MA PDU Non 3GPP User Location Time	-	This field is not applicable.



UE Time Zone	O <sub>C</sub>	Described in table 6.2.1.2.
Presence Reporting Area Information	O <sub>C</sub>	This field is not applicable..
PDU Session Information	O <sub>C</sub>	Described in table 6.2.1.2.
PDU Session ID	M	Described in table 6.2.1.2.
Network Slice Instance Identifier	-	This field is not applicable.
PDU Type	O <sub>M</sub>	Described in table 6.2.1.2.
PDU Address	O <sub>C</sub>	Described in table 6.2.1.2.
PDU Ipv4 Address	O <sub>C</sub>	Described in table 6.2.1.2.
PDU IPv6 Address with Prefix	O <sub>C</sub>	Described in table 6.2.1.2.
PDU Address prefix length	O <sub>C</sub>	Described in table 6.2.1.2.
IPv4 Dynamic Address Flag	O <sub>C</sub>	Described in table 6.2.1.2.
IPv6 Dynamic Address Flag	O <sub>C</sub>	Described in table 6.2.1.2.
SSC Mode	-	This field is not applicable.
MA PDU session information	-	This field is not applicable.
MA PDU session indicator	-	This field is not applicable.
ATSSS capability	-	This field is not applicable.
SUPI PLMN ID	O <sub>C</sub> -	Described in table 6.2.1.2.
Serving Network Function ID	O <sub>C</sub>	Described in table 6.2.1.2.
Serving Network Function Functionality	M	Described in table 6.2.1.2. This field holds "SGSN" when SMF+PGW-C serves GERAN/UTRAN access.
Serving Network Function Name	-	Described in table 6.2.1.2.
Serving Network Function Addresses	O <sub>C</sub>	Described in table 6.2.1.2.
Serving Network Function FQDN	O <sub>C</sub>	Described in table 6.2.1.2.
Serving Network Function PLMN ID	O <sub>C</sub>	Described in table 6.2.1.2.
AMF Identifier	-	This field is not applicable.
Serving CN PLMN ID	O <sub>C</sub>	Described in table 6.2.1.2.
RAT Type	O <sub>C</sub>	Described in table 6.2.1.2.
MA PDU Non 3GPP RAT Type	-	This field is not applicable.
Data Network Name Identifier	M	Described in table 6.2.1.2, with DNN replaced by APN.
DNN Selection Mode	-	This field is not applicable.
Authorized QoS Information	O <sub>C</sub>	Described in table 6.2.1.2 QoS information mapped according interaction with PCC as specified in clause 4.11.0a.2 of TS 23.502 [201]
Subscribed QoS Information	O <sub>C</sub>	Described in table 6.2.1.2 QoS information mapped according interaction with PCC as specified in clause 4.11.0a.2 of TS 23.502 [201].
Authorized Session-AMBR	O <sub>C</sub>	Described in table 6.2.1.2.
Subscribed Session-AMBR	O <sub>C</sub>	Described in table 6.2.1.2.
PDU session start Time	O <sub>C</sub>	Described in table 6.2.1.2.
PDU session stop Time	O <sub>C</sub>	Described in table 6.2.1.2.
Diagnostics	O <sub>C</sub>	Described in table 6.2.1.2.
Enhanced Diagnostics	O <sub>C</sub>	Described in table 6.2.1.2.
Charging Characteristics	O <sub>C</sub>	Described in table 6.2.1.2.
Charging Characteristics Selection Mode	O <sub>C</sub>	Described in table 6.2.1.2.
3GPP PS Data Off Status	O <sub>C</sub>	Described in table 6.2.1.2.
Session Stop Indicator	-	This field is not applicable.
Redundant Transmission Type	-	This field is not applicable.
PDU Session pair ID	-	This field is not applicable.
Unit Count Inactivity Timer	-	This field is not applicable.
RAN Secondary RAT Usage Report	-	This field is not applicable.

The specific PDU Container Information when UE is connected to SMF+P-GW-C via GERAN/UTRAN is provided as defined in table 6.2.1.3.1, with the differences described under following table C.3.2.1-2:

**Table C.3.2.1-2: Structure of PDU Container Information**

Information Element	Category	Description
Time of First Usage	O <sub>C</sub>	Described in table 6.2.1.3.1.

Information Element	Category	Description
Time of Last Usage	O <sub>C</sub>	Described in table 6.2.1.3.1.
QoS Information	O <sub>C</sub>	Described in table 6.2.1.3.1.
QoS Characteristics	O <sub>C</sub>	Described in table 6.2.1.3.1.
AF Charging Identifier	O <sub>C</sub>	Described in table 6.2.1.3.1.
AF Charging Id String	O <sub>C</sub>	Described in table 6.2.1.3.1.
User Location Information	O <sub>C</sub>	Described in table 6.2.1.3.1.
UE Time Zone	O <sub>C</sub>	Described in table 6.2.1.3.1.
Presence Reporting Area Information	O <sub>C</sub>	Described in table 6.2.1.3.1.
Serving Network Function ID	O <sub>C</sub>	Described in table 6.2.1.3.1.
RAT Type	O <sub>C</sub>	Described in table 6.2.1.3.1.
Sponsor Identity	O <sub>C</sub>	Described in table 6.2.1.3.1.
Application Service Provider Identity	O <sub>C</sub>	Described in table 6.2.1.3.1.
Charging Rule Base Name	O <sub>C</sub>	Described in table 6.2.1.3.1.
3GPP PS Data Off Status	O <sub>C</sub>	Described in table 6.2.1.3.1.
MA PDU Steering functionality	-	This field is not applicable.
MA PDU Steering mode	-	This field is not applicable.

The specific Roaming QBC information is described in table B.2.2.1.2-1 and QFI Container Information is described in table B.2.2.1.3-1 for when UE is connected to SMF+P-GW via GERAN/UTRAN, with the differences that PDU session is replaced by PDP context in fields description.

### C.3.2.2 Detailed message format for converged charging

The basic structure of supported fields in *Charging Data Request/Response* message defined in clause 6.2.2 shall apply for fields applicable when SMF+PGW-C supports GERAN/UTRAN access.

### C.3.2.3 Formal 5G data connectivity charging parameter description

The CHF CDR parameters and resources attributes defined in clause 6.2.3 shall apply for fields applicable when SMF+PGW-C supports GERAN/UTRAN access.

---

## Annex D (informative): Network slice charging based on 5G data connectivity

### D.1 General

This clause describes how to realise Network Slice usage charging, when the Network Slice is identified by an S-NSSAI (Single Network Slice Selection Assistance Information), and the Network Slice usage is considered under 5G data connectivity by individual UEs.

The existing Nchf capabilities exposed by CHF to SMF for individual UE 5G data connectivity charging can be used for this purpose when the Mobile Network Operator (MNO) serving the UE is also acting as the Network Slice (NS) Tenant(s).

A given S-NSSAI can be Tenant specific or shared between multiple Tenants.

The MNO Converged Charging system encompasses both individual UEs and NS Tenants(s).

Roaming scenarios are out of scope of this Annex, therefore unless otherwise stated, references to clauses in this document refer to description applicable for non-roaming scenarios only.

---

### D.2 Architecture

The 5G data connectivity domain converged charging architectures in clause 4.2 of this document apply, with the CHF hosted by Converged Charging system (CCS) extended for Network Slice (NS) Tenant.

The single CCS or multiple CCSs may be used to support converged charging for tenant and UEs belonging to the tenant at same time, which is implementation specific, the interaction of CCS(s) are out of scope of this Annex.

---

### D.3 Network slice charging based on 5G data connectivity principles

#### D.3.1 General

The MNO as the Network Slice (NS) Tenant, is assigned with one or more S-NSSAI(s), each S-NSSAI identifying a Network Slice.

The 5G charging supports converged charging per PDU session based on assigned group of S-NSSAI(s).

Converged Charging systems are deployed and configured by the MNO in order to achieve Network slice charging per S-NSSAI. A given Converged charging system can be configured to handle one or more S-NSSAI(s).

Individual UE, when subscribed to the MNO's particular S-NSSAI, is served by the Converged Charging system allocated to this S-NSSAI, when this UE establishes a PDU session under this S-NSSAI.

5G data connectivity charging performed for individual UE over Nchf exposed by the CHF is used to perform Network Slice charging for the NS Tenant for a particular S-NSSAI.

## D.4 Network slice charging based on 5G data connectivity scenarios

### D.4.1 Basic principles

#### D.4.1.1 CHF selection

The CHF selection mechanism at PDU session establishment defined in clause 5.1.8 of this specification, allows the SMF to reach the CHF hosted by the Converged Charging system serving the UE belongs to the particular S-NSSAI and Tenant.

### D.4.2 Message flows

The message flows in clause 5.2.2 apply. The following figure provides a simplified description focusing on Network slice usage charging for a S-NSSAI.

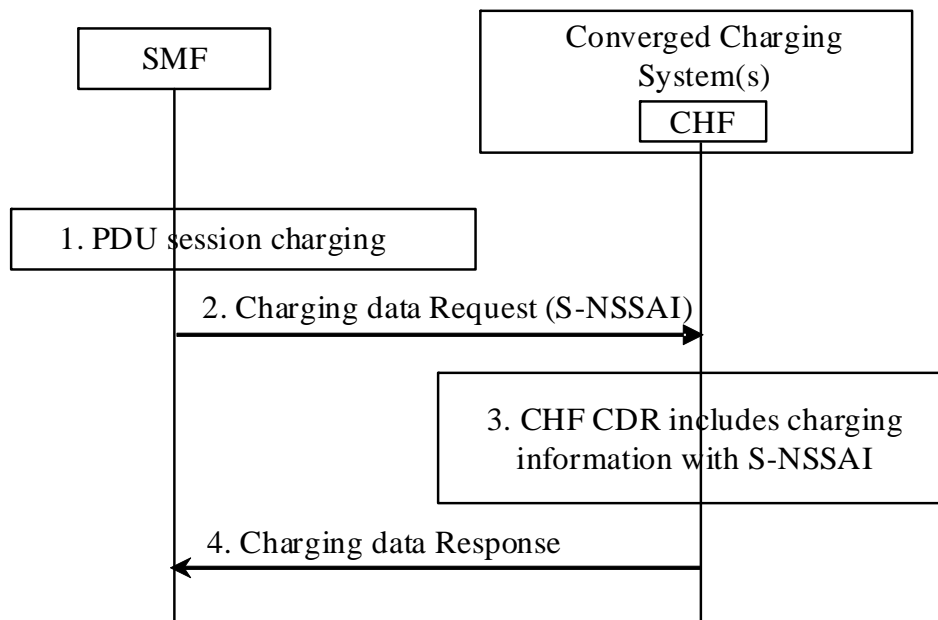

**Figure D.4.2-1: Network slice charging based on 5G data connectivity**

1. The SMF collects the charging information for PDU session.
2. The SMF reports the PDU session information with S-NSSAI.
3. CHF includes S-NSSAI in the CDR for the PDU session.
4. CHF sends the charging data response.

## D.5 Definition of charging information

The definition of charging information in clause 6 is applicable for the purpose of Network Slice charging based on 5G data connectivity.

The "Network Slice Instance Identifier" Information Element in subclause 6.2.1.2 Table 6.2.1.2.1: Structure of PDU Session Charging Information is the key identifier S-NSSAI conveyed over Nchf and in CDRs on the Bd interface.

## Annex E (informative): Change history

Change history							
Date	Meeting	TDoc	CR	Rev	Cat	Subject/Comment	New version
2018-09	SA#81					Upgrade to change control version	15.0.0
2018-12	SA#82	SP-181057	0001	1	F	Correction on the User Information	15.1.0
2018-12	SA#82	SP-181057	0002	1	F	Clarification of Charging Characteristics in roaming	15.1.0
2018-12	SA#82	SP-181057	0003	1	F	Clarification of CHF selection	15.1.0
2018-12	SA#82	SP-181057	0004	1	F	Clarification of Charging Identifier	15.1.0
2018-12	SA#82	SP-181057	0029	-	F	Correction on flows for alignment with TS 23.502	15.1.0
2018-12	SA#82	SP-181057	0007	1	F	Allow updating of Notify URI	15.1.0
2018-12	SA#82	SP-181057	0008	1	F	Correction of Invocation result at http ok	15.1.0
2018-12	SA#82	SP-181057	0009	1	F	Correction of Online non-blocking handling	15.1.0
2018-12	SA#82	SP-181057	0010	1	F	Correction of UPF Id definition	15.1.0
2018-12	SA#82	SP-181057	0011	1	F	Correction of Serving Network Function ID definition	15.1.0
2018-12	SA#82	SP-181057	0012	1	F	Correction of Unused Quota Timer naming	15.1.0
2018-12	SA#82	SP-181057	0013	1	B	Introduction Data Volume Reporting for Option 4&7	15.1.0
2018-12	SA#82	SP-181057	0014	1	F	Complete flows alignment with TS 23.502	15.1.0
2018-12	SA#82	SP-181057	0015	1	F	PRA Charging Clarification	15.1.0
2018-12	SA#82	SP-181057	0016	1	F	Add missing clause on formal description	15.1.0
2019-03	SA#83	SP-190115	0030	-	F	Correction of category for subscriber identifier	15.2.0
2019-03	SA#83	SP-190116	0035	1	F	Correction of NF Consumer Information	15.2.0
2019-03	SA#83	SP-190116	0044	1	F	Correct definition of Individual Partial record mechanism	15.2.0
2019-03	SA#83	SP-190115	0046	1	F	Correction of QoS Information	15.2.0
2019-03	SA#83	SP-190115	0047	1	F	Correction of user information	15.2.0
2019-03	SA#83	SP-190115	0048	1	F	Correction of serving network function	15.2.0
2019-03	SA#83	SP-190115	0049	1	F	Correction of Trigger Conditions for FBC	15.2.0
2019-03	SA#83	SP-190115	0050	1	F	Remove Quota Consumption Time	15.2.0
2019-03	SA#83	SP-190112	0033	1	B	Addition of the Triggers for Interworking	16.0.0
2019-03	SA#83	SP-190112	0034	1	B	Addition of the Message flow for Interworking	16.0.0
2019-03	SA#83	SP-190127	0035	1	B	Add offline only charging	16.0.0
2019-03	SA#83	SP-190127	0036	1	B	Add offline only charging for SMF	16.0.0
2019-03	SA#83	SP-190127	0038	1	B	Add offline only charging CDR generation	16.0.0
2019-03	SA#83	SP-190127	0039	1	B	Add description of charging information for offline only charging	16.0.0
2019-03	SA#83	SP-190127	0040	1	B	Add offline only charging for flow based charging	16.0.0
2019-03	SA#83	SP-190127	0041	1	B	Add offline only charging for QoS flow based charging	16.0.0
2019-03	SA#83	SP-190127	0043	2	B	Add offline only charging triggers for SSC modes	16.0.0
2019-03	SA#83	SP-190127	0045	1	B	Add Offline charging service procedures.	16.0.0
2019-03	SA#83	SP-190127	0051	1	B	Add offline only charging for CHF selection	16.0.0
2019-06	SA#84	SP-190381	0057	1	B	Clarify the charging session for interworking	16.1.0
2019-06	SA#84	SP-190381	0058	1	B	Add the quota management for Interworking	16.1.0
2019-06	SA#84	SP-190381	0059	1	B	Definition of charging information for interworking with EPC	16.1.0
2019-06	SA#84	SP-190382	0060	1	B	Add detailed message format for offline charging	16.1.0
2019-06	SA#84	SP-190382	0062	1	B	CHF selection in offline only	16.1.0
2019-06	SA#84	SP-190382	0065	1	D	Correction of missing SDF abbreviation	16.1.0
2019-06	SA#84	SP-190383	0066	-	A	Correction of Start of a QoS Flow trigger	16.1.0
2019-09	SA#85	SP-190757	0067	1	B	Clarification for EPC interworking triggers	16.2.0
2019-09	SA#85	SP-190757	0068	-	B	EPC interworking call flow correction	16.2.0
2019-09	SA#85	SP-190757	0070	1	B	Modify the Charging id	16.2.0
2019-09	SA#85	SP-190757	0071	1	B	Message flow for 5GS and EPC interworking in Home routed scenario	16.2.0
2019-09	SA#85	SP-190757	0072	1	B	Definition of charging information for interworking with EPC	16.2.0
2019-09	SA#85	SP-190758	0073	1	B	Introduce offline only determination by SMF	16.2.0
2019-09	SA#85	SP-190759	0074	1	A	Correction of Serving Node change	16.2.0
2019-09	SA#85	SP-190759	0076	1	F	Correction of Termination action	16.2.0
2019-09	SA#85	SP-190757	0082	1	B	Clarification on RAT Type change	16.2.0
2019-09	SA#85	SP-190759	0083	1	A	Add the selection model in PDU session information	16.2.0
2019-09	SA#85	SP-190759	0086	1	A	Coordination of information element category	16.2.0
2019-09	SA#85	SP-190759	0087	-	A	Correction of PDU session charging information definition	16.2.0
2019-09	SA#85	SP-190759	0090	1	F	Correction of AF Charging Identifier naming	16.2.0
2019-12	SA#86	SP-191155	0107	-	A	Add the Service specification Information	16.3.0
2019-12	SA#86	SP-191159	0108	1	F	Add the Qos Characteristics	16.3.0
2019-12	SA#86	SP-191155	0109	1	A	Add the QNC support	16.3.0
2019-12	SA#86	SP-191155	0110	1	A	Correction of PCC rules description	16.3.0
2019-12	SA#86	SP-191155	0111	-	A	Correction of UPF ID in CHF CDR data	16.3.0
2019-12	SA#86	SP-191155	0113	1	A	Clarification of sponsored data connectivity charging	16.3.0
2019-12	SA#86	SP-191155	0114	1	A	Correction of Unit Count Inactivity Timer	16.3.0
2019-12	SA#86	SP-191167	0115	1	B	Add charging requirement for I-SMF	16.3.0
2019-12	SA#86	SP-191167	0116	1	B	Add charging principle for I-SMF	16.3.0
2019-12	SA#86	SP-191167	0117	1	B	Add charging trigger conditions for I-SMF	16.3.0
2019-12	SA#86	SP-191167	0118	1	B	Add I-SMF PDU session charging information	16.3.0
2019-12	SA#86	SP-191151	0121	1	F	Correction of Interworking flow	16.3.0

2019-12	SA#86	SP-191155	0122	-	F	Correction of Container definition	16.3.0
2019-12	SA#86	SP-191159	0123	1	F	Correction of QoS Based Charging description	16.3.0
2019-12	SA#86	SP-191159	0124	1	F	Definition of Emergency Session handling	16.3.0
2019-12	SA#86	SP-191177	0126	1	F	Missing default trigger for Offline only	16.3.0
2019-12	SA#86	SP-191167	0127	1	B	Adding ETSUN architecture with I-SMF insertion	16.3.0
2019-12	SA#86	SP-191167	0129	1	B	Adding I-SMF in 5G data connectivity charging information	16.3.0
2019-12	SA#86	SP-191167	0132	1	B	Adding I-SMF in PDU Session Charging message flow	16.3.0
2019-12	SA#86	SP-191167	0133	1	B	PDU Session modification procedure with I-SMF involved	16.3.0
2019-12	SA#86	SP-191167	0134	1	B	PDU session release procedure with I-SMF involved	16.3.0
2019-12	SA#86	SP-191167	0135	1	B	PDU Session procedures with I-SMF insertion/change/removal	16.3.0
2019-12	SA#86	SP-191151	0139	1	F	Correction of handover triggers	16.3.0
2019-12	SA#86	SP-191167	0142	1	B	Adding I-SMF triggers related actions in SMF	16.3.0
2019-12	SA#86	SP-191167	0144	1	B	Add CDR trigger condition for change of I-SMF	16.3.0
2019-12	SA#86	SP-191167	0145	1	B	Add charging ID assigned by SMF with I-SMF	16.3.0
2019-12	SA#86	SP-191156	0153	1	A	Correction of Unit Count Inactivity Timer	16.3.0
2019-12	SA#86	SP-191156	0154	1	A	Alignment of Rating Indicator	16.3.0
2019-12	SA#86	SP-191156	0155	1	A	Clarify on limit for multiple UPFs	16.3.0
2019-12	SA#86	SP-191156	0156	1	A	Clarify on the triggers for time and volume	16.3.0
2019-12	SA#86	SP-191167	0160	1	B	Adding I-SMF controlled UPF triggers per RG level	16.3.0
2019-12	SA#86	SP-191156	0162	1	A	Correction of charging rule base name	16.3.0
2020-03	SA#87E	SP-200170	0140	2	B	5GS to EPS handover using N26 interface with I-SMF	16.4.0
2020-03	SA#87E	SP-200170	0141	2	B	EPS to 5GS handover using N26 interface with I-SMF	16.4.0
2020-03	SA#87E	SP-200170	0167	1	B	Introduction of V-SMF change in Roaming HR - principles	16.4.0
2020-03	SA#87E	SP-200179	0168	1	B	Introduction of ATSSS architecture reference and charging requirements	16.4.0
2020-03	SA#87E	SP-200179	0169	1	B	Introduction of MA PDU session and PCC Rules	16.4.0
2020-03	SA#87E	SP-200179	0170	1	B	Introduction of ATSSS flows	16.4.0
2020-03	SA#87E	SP-200179	0172	1	B	Introduction of V-SMF change in Roaming HR - flows	16.4.0
2020-03	SA#87E	SP-200179	0182	2	B	Add the branching point or UL CL controlled by I-SMF	16.4.0
2020-03	SA#87E	SP-200164	0185	1	B	Add 5WWC charging requirements	16.4.0
2020-03	SA#87E	SP-200164	0186	1	B	Add 5WWC charging requirements	16.4.0
2020-03	SA#87E	SP-200164	0188	1	B	Add procedure for 5G-RG scenario	16.4.0
2020-03	SA#87E	SP-200164	0189	2	B	Add procedure for FN-RG scenario	16.4.0
2020-03	SA#87E	SP-200164	0190	2	B	Add description on identifier in a PDU session for 5G RG and FN RG	16.4.0
2020-03	SA#87E	SP-200170	0200	2	B	Addition/removal/change of PSA2 and UL CL or BP controlled by I-SMF	16.4.0
2020-03	SA#87E	SP-200170	0203	1	B	Remove Editor's note of PDU Session establishment with I-SMF insertion	16.4.0
2020-03	SA#87E	SP-200182	0204	3	B	Introduce CHF-Controlled Quota Management	16.4.0
2020-07	SA#88E	SP-200484	0212	1	F	Add the Retransmission Indicator	16.5.0
2020-07	SA#88E	SP-200505	0214	1	B	Add description on charging information	16.5.0
2020-07	SA#88E	SP-200505	0215	1	B	Add procedure for 5G-RG handover	16.5.0
2020-07	SA#88E	SP-200506	0217	1	F	Correction of Charging Identifier definition	16.5.0
2020-07	SA#88E	SP-200495	0218	2	B	Introduction of MA PDU session information	16.5.0
2020-07	SA#88E	SP-200495	0219	1	B	Clarify ATSSS when same rating group for 3GPP and non-3GPP	16.5.0
2020-07	SA#88E	SP-200495	0220	-	B	Introduction of ATSSS Roaming Home Routed Network requested	16.5.0
2020-07	SA#88E	SP-200495	0221	1	B	Introduction of ATSSS Roaming Home Routed UE requested	16.5.0
2020-07	SA#88E	SP-200495	0222	-	B	Introduction of ATSSS EPS interworking	16.5.0
2020-07	SA#88E	SP-200507	0223	1	F	Correction of Serving Network Function Functionality for I-SMF	16.5.0
2020-07	SA#88E	SP-200495	0224	-	B	Introduction of architecture reference for ATSSS Hybrid access	16.5.0
2020-07	SA#88E	SP-200495	0225	-	B	Introduction of flows for ATSSS Hybrid access NG-RAN and W-5GAN	16.5.0
2020-07	SA#88E	SP-200495	0226	-	B	Introduction of flows for ATSSS Hybrid access EPC and W-5GAN	16.5.0
2020-07	SA#88E	SP-200495	0227	1	B	Introduction of non-3GPP access information for MA PDU session	16.5.0
2020-07	SA#88E	SP-200495	0228	-	B	Introduction of ATSSS triggers and CDR handling	16.5.0
2020-07	SA#88E	SP-200495	0229	1	B	Introduction of MA PDU information in detailed messages	16.5.0
2020-07	SA#88E	SP-200485	0230	1	F	Correct the PDU address	16.5.0
2020-07	SA#88E	SP-200505	0232	1	B	Add Trusted non-3GPP access related charging requirements	16.5.0
2020-07	SA#88E	SP-200508	0233	1	B	Settings of Supported Features for CHFCQM	16.5.0
2020-07	SA#88E	SP-200485	0234	1	F	Correcting of PDU session information in charging data response	16.5.0
2020-09	SA#89e	SP-200740	0236	1	F	Charging Id Handling 5GC interworking with EPC	16.6.0
2020-09	SA#89e	SP-200740	0237	1	F	Clarify Charging information 5GC interworking with EPC	16.6.0
2020-09	SA#89e	SP-200733	0238	-	B	Completion of ATSSS triggers	16.6.0
2020-09	SA#89e	SP-200813	0239	1	F	Correction of missing AF Charging Id in string format	16.6.0
2020-09	SA#89e	SP-200740	0242	1	F	Add EPC/ePDG interworking procedures	16.6.0
2020-09	SA#89e	SP-200740	0243	1	F	Add ePDG as serving node	16.6.0
2020-09	SA#89e	SP-200816	0245	1	F	Align 5WWC RAT types	16.6.0



2020-09	SA#89e	SP-200813	0246	1	F	Correct architecture figures and description about CHF selection.	16.6.0
2020-09	SA#89e	SP-200813	0247	1	F	Add PDU Address in for IPv6 multi-homing	16.6.0
2020-09	SA#89e					Editorial corrections after CR implementation	16.6.1
2020-12	SA#90e	SP-201076	0248	-	F	Correction of Charging Id in roaming HR scenario upon V-SMF change	16.7.0
2020-12	SA#90e	SP-201051	0249	1	F	Add Multi-homed PDU Address in CHF-CDR for IPv6 multi-homing	16.7.0
2020-12	SA#90e	SP-201051	0250	1	F	Add the QNC subscription	16.7.0
2020-12	SA#90e	SP-201051	0252	1	F	Add the enhanced Diagnostics for 5G Charging	16.7.0
2020-12	SA#90e	SP-201051	0256	1	F	Correcting UPF addition trigger	16.7.0
2020-12	SA#90e	SP-201088	0259	1	F	Correction on the QoS information in PDU Container	16.7.0
2020-12	SA#90e	SP-201088	0265	1	F	Correction on the Quota Management Mode	16.7.0
2020-12	SA#90e	SP-201088	0266	1	F	Correction of PDU session modification flow	16.7.0
2020-12	SA#90e	SP-201067	0254	1	B	Add URLLC Charging Requirement	17.0.0
2020-12	SA#90e	SP-201067	0255	1	B	Add Highly reliable URLLC services Charging	17.0.0
2020-12	SA#90e	SP-201067	0260	1	B	Add Triggers for URLLC services	17.0.0
2020-12	SA#90e	SP-201067	0261	1	B	Add Message Flow for URLLC services	17.0.0
2020-12	SA#90e	SP-201067	0263	1	B	Add Charging Principle for Usage Reporting	17.0.0
2021-03	SA#91e	SP-210160	0271	1	A	Correct steps in V-SMF change procedure	17.1.0
2021-03	SA#91e	SP-210161	0274	1	B	Add the PDU Modification and Release Message flow	17.1.0
2021-03	SA#91e	SP-210161	0275	1	B	Add PDU Modification and Release Message flow for URLLC Charging	17.1.0
2021-03	SA#91e	SP-210161	0276	1	B	Add the Quota Management for URLLC Charging	17.1.0
2021-03	SA#91e	SP-210161	0277	1	B	Add the Usage Reporting for URLLC Charging	17.1.0
2021-03	SA#91e	SP-210161	0278	1	B	Add Charging Information for URLLC Charging	17.1.0
2021-03	SA#91e	SP-210160	0280	-	A	Correction of V-SMF Change in Roaming HR - flows	17.1.0
2021-03	SA#91e	SP-210149	0282	1	A	Correction of PDU Session Information	17.1.0
2021-03	SA#91e	SP-210162	0285	-	A	Correcting missing handover cancel in table	17.1.0
2021-03	SA#91e	SP-210149	0287	1	A	Charging id clarification	17.1.0
2021-03	SA#91e	SP-210147	0289	1	A	Trigger Override clarification	17.1.0
2021-03	SA#91e	SP-210147	0291	-	A	Add the description for the trigger Conditions	17.1.0
2021-03	SA#91e	SP-210147	0293	1	A	Correct the description for the Multiple UPFs	17.1.0
2021-03	SA#91e	SP-210147	0295	1	A	Correction of Termination action	17.1.0
2021-03	SA#91e	SP-210147	0297	1	A	Correction of Charging Id assigned by the V-SMF	17.1.0
2021-03	SA#91e					Correction of error in CR implementation	17.1.1
2021-06	SA#92e	SP-210466	0301	1	B	Support of GERAN/UTRAN access by SMF+PGW-C	17.2.0
2021-06	SA#92e	SP-210418	0303	1	A	Correct the handover description	17.2.0
2021-06	SA#92e	SP-210418	0305	1	A	Correct the PAR reporting information	17.2.0
2021-06	SA#92e	SP-210396	0306	1	B	Correct the message flow for URLLC Charging	17.2.0
2021-06	SA#92e	SP-210396	0307	1	B	Add the definition for non-redundant transmission	17.2.0
2021-06	SA#92e	SP-210396	0309	1	B	Add RSN for URLLC Charging	17.2.0
2021-06	SA#92e	SP-210407	0310	1	C	Correction on Reference Points for 5GS	17.2.0
2021-06	SA#92e	SP-210418	0312	-	A	Correction on support of CHF set	17.2.0
2021-06	SA#92e	SP-210400	0314	1	A	Correction on PDU address using DHCPv6 for connected RG to 5GC	17.2.0
2021-09	SA#93e	SP-210863	0319	1	B	Addition of the PDU Session Pair ID	17.3.0
2021-09	SA#93e	SP-210863	0321	1	B	Correction on usage reporting for URLLC charging	17.3.0
2021-09	SA#93e	SP-210888	0322	1	B	Update description for charging message in Annex C.2	17.3.0
2021-09	SA#93e	SP-210886	0324	-	A	Addition of supported fields for the Offline Only Charging	17.3.0
2021-09	SA#93e	SP-210886	0326	-	A	Correction on Charging Data Request Message	17.3.0
2021-09	SA#93e	SP-210886	0328	-	A	Alignment of the charging data request and response	17.3.0
2021-09	SA#93e	SP-210886	0330	1	A	Correcting serving network function usage	17.3.0
2021-12	SA#94e	SP-211485	0332	1	A	Correction of default chargeable events in SMF for QBC	17.4.0
2021-12	SA#94e	SP-211463	0333	1	F	Correcting charging identifier for NF set	17.4.0
2021-12	SA#94e	SP-211463	0334	-	F	Correcting missing termination in V-SMF change	17.4.0
2021-12	SA#94e	SP-211463	0335	1	F	Correcting unit count inactivity timer enablement	17.4.0
2021-12	SA#94e	SP-211485	0337	-	A	Correcting UPF trigger in QBC	17.4.0
2021-12	SA#94e	SP-211481	0338	2	F	Addition of QoS Monitoring to Assist URLLC Service	17.4.0
2021-12	SA#94e	SP-211481	0341	-	F	Correction on Redundant Transmission Indication	17.4.0
2021-12	SA#94e	SP-211485	0345	1	A	Remove the CHF address transfer in the Intra-PLMN change	17.4.0
2021-12	SA#94e	SP-211463	0347	-	F	Correcting SSC mode and triggers	17.4.0
2021-12	SA#94e	SP-211463	0348	1	F	Correcting home provided charging id at inter-PLMN V-SMF change	17.4.0
2021-12	SA#94e	SP-211480	0350	1	B	Addition of the 5G LAN service charging in charging principle	17.4.0
2021-12	SA#94e	SP-211480	0351	1	B	Addition of the 5G LAN service charging requirements	17.4.0
2021-12	SA#94e	SP-211485	0353	1	A	Correction on the User Location Time Description	17.4.0
2021-01						Re-upload due to previous corrupted version	17.4.1
2022-03	SA#95e	SP-220164	0354	1	B	Clarification on the 5G LAN type service charging	17.5.0
2022-03	SA#95e	SP-220164	0355	1	B	Additional charging information for the 5G LAN charging	17.5.0
2022-03	SA#95e	SP-220159	0361	1	B	Add charging enhancements of 5GS CIoT in charging procedure	17.5.0
2022-03	SA#95e	SP-220159	0362	1	B	Add charging enhancements of 5GS CIoT in EPC interworking procedure	17.5.0

2022-03	SA#95e	SP-220159	0363	1	B	Add charging enhancements of 5GS Clot in home-routed roaming procedure	17.5.0
2022-03	SA#95e	SP-220159	0364	1	B	Add charging information of 5GS Clot	17.5.0
2022-03	SA#95e	SP-220159	0365	1	B	Add charging requirements of 5GS Clot	17.5.0
2022-03	SA#95e	SP-220157	0366	1	B	Introduction of Annex on Network slice charging	17.5.0
2022-03	SA#95e	SP-220186	0367	1	F	Correcting charging rule base name	17.5.0
2022-03	SA#95e	SP-220175	0368	1	B	Add charging information for 5GS usage for Edge Computing	17.5.0
2022-03	SA#95e	SP-220169	0369	1	B	Add charging requirement to support NR RedCap	17.5.0
2022-06	SA#96	SP-220517	0377	1	B	Additional the architecture for LBO	17.6.0
2022-06	SA#96	SP-220517	0378	1	B	Additional converged charging architecture for LBO	17.6.0
2022-06	SA#96	SP-220517	0379	1	B	Additional charging requirement for LBO	17.6.0
2022-06	SA#96	SP-220517	0380	1	B	Clarification on sponsored data connectivity charging for LBO	17.6.0
2022-06	SA#96	SP-220517	0381	3	B	Additional charging message flow for LBO	17.6.0
2022-06	SA#96	SP-220517	0382	3	B	Additional charging principles for LBO	17.6.0
2022-06	SA#96	SP-220496	0390	-	F	Correcting support of charging scenarios for roaming	17.6.0
2022-06	SA#96	SP-0220520	0391	-	F	Correcting usage of PDU session information	17.6.0
2022-06	SA#96	SP-0220520	0392	1	F	Correcting home routed CHF selection	17.6.0
2022-06	SA#96	SP-220565	0397	1	A	Correction on the Trigger Conditions	17.6.0
2022-06	SA#96	SP-220565	0399	1	A	Correction on the trigger type for QBC	17.6.0
2022-06	SA#96	SP-220496	0401	-	F	Correction on the description for Interworking Charging	17.6.0
2022-06	SA#96	SP-220517	0402	1	B	Additional charging message flow for MVNO	17.6.0
2022-06	SA#96	SP-220517	0403	1	B	Additional charging principles for MVNO	17.6.0
2022-06	SA#97e	SP-220850	0404	1	F	Correction on Home Provided Charging Id and Roaming Charging Profile	17.7.0
2022-06	SA#97e	SP-220850	0409	1	F	Correction on the Charging Identifier Uniqueness	17.7.0
2022-12	SA#98e	SP-221168	0410	1	F	Correction on usage of PLMN-ID in Charging Id	17.8.0
2023-03	SA#99	SP-230198	0414	-	A	Correct the change of PRA for Roaming	17.9.0
2023-03	SA#99	SP-230197	0415	1	F	Correction of UPFIId in QBC	17.9.0
2023-03	SA#99	SP-230197	0416	1	F	Inconsistent use of charging identifier	17.9.0

---

# History

<b>Document history</b>		
V17.5.0	May 2022	Publication
V17.6.0	July 2022	Publication
V17.7.0	October 2022	Publication
V17.8.0	January 2023	Publication
V17.9.0	April 2023	Publication