

ETSI TS 132 257 V17.1.0 (2022-10)



**5G;
Telecommunication management; Charging management;
Edge computing domain charging
(3GPP TS 32.257 version 17.1.0 Release 17)**



Reference

RTS/TSGS-0532257vh10

Keywords

5G

ETSI

650 Route des Lucioles
F-06921 Sophia Antipolis Cedex - FRANCE

Tel.: +33 4 92 94 42 00 Fax: +33 4 93 65 47 16

Siret N° 348 623 562 00017 - APE 7112B
Association à but non lucratif enregistrée à la
Sous-Préfecture de Grasse (06) N° w061004871

Important notice

The present document can be downloaded from:

<http://www.etsi.org/standards-search>

The present document may be made available in electronic versions and/or in print. The content of any electronic and/or print versions of the present document shall not be modified without the prior written authorization of ETSI. In case of any existing or perceived difference in contents between such versions and/or in print, the prevailing version of an ETSI deliverable is the one made publicly available in PDF format at www.etsi.org/deliver.

Users of the present document should be aware that the document may be subject to revision or change of status.

Information on the current status of this and other ETSI documents is available at

<https://portal.etsi.org/TB/ETSIDeliverableStatus.aspx>

If you find errors in the present document, please send your comment to one of the following services:

<https://portal.etsi.org/People/CommitteeSupportStaff.aspx>

If you find a security vulnerability in the present document, please report it through our
Coordinated Vulnerability Disclosure Program:

<https://www.etsi.org/standards/coordinated-vulnerability-disclosure>

Notice of disclaimer & limitation of liability

The information provided in the present deliverable is directed solely to professionals who have the appropriate degree of experience to understand and interpret its content in accordance with generally accepted engineering or other professional standard and applicable regulations.

No recommendation as to products and services or vendors is made or should be implied.

No representation or warranty is made that this deliverable is technically accurate or sufficient or conforms to any law and/or governmental rule and/or regulation and further, no representation or warranty is made of merchantability or fitness for any particular purpose or against infringement of intellectual property rights.

In no event shall ETSI be held liable for loss of profits or any other incidental or consequential damages.

Any software contained in this deliverable is provided "AS IS" with no warranties, express or implied, including but not limited to, the warranties of merchantability, fitness for a particular purpose and non-infringement of intellectual property rights and ETSI shall not be held liable in any event for any damages whatsoever (including, without limitation, damages for loss of profits, business interruption, loss of information, or any other pecuniary loss) arising out of or related to the use of or inability to use the software.

Copyright Notification

No part may be reproduced or utilized in any form or by any means, electronic or mechanical, including photocopying and microfilm except as authorized by written permission of ETSI.

The content of the PDF version shall not be modified without the written authorization of ETSI.

The copyright and the foregoing restriction extend to reproduction in all media.

© ETSI 2022.
All rights reserved.

Intellectual Property Rights

Essential patents

IPRs essential or potentially essential to normative deliverables may have been declared to ETSI. The declarations pertaining to these essential IPRs, if any, are publicly available for **ETSI members and non-members**, and can be found in ETSI SR 000 314: "*Intellectual Property Rights (IPRs); Essential, or potentially Essential, IPRs notified to ETSI in respect of ETSI standards*", which is available from the ETSI Secretariat. Latest updates are available on the ETSI Web server (<https://ipr.etsi.org/>).

Pursuant to the ETSI Directives including the ETSI IPR Policy, no investigation regarding the essentiality of IPRs, including IPR searches, has been carried out by ETSI. No guarantee can be given as to the existence of other IPRs not referenced in ETSI SR 000 314 (or the updates on the ETSI Web server) which are, or may be, or may become, essential to the present document.

Trademarks

The present document may include trademarks and/or tradenames which are asserted and/or registered by their owners. ETSI claims no ownership of these except for any which are indicated as being the property of ETSI, and conveys no right to use or reproduce any trademark and/or tradename. Mention of those trademarks in the present document does not constitute an endorsement by ETSI of products, services or organizations associated with those trademarks.

DECT™, **PLUGTESTS™**, **UMTS™** and the ETSI logo are trademarks of ETSI registered for the benefit of its Members. **3GPP™** and **LTE™** are trademarks of ETSI registered for the benefit of its Members and of the 3GPP Organizational Partners. **oneM2M™** logo is a trademark of ETSI registered for the benefit of its Members and of the oneM2M Partners. **GSM®** and the GSM logo are trademarks registered and owned by the GSM Association.

Legal Notice

This Technical Specification (TS) has been produced by ETSI 3rd Generation Partnership Project (3GPP).

The present document may refer to technical specifications or reports using their 3GPP identities. These shall be interpreted as being references to the corresponding ETSI deliverables.

The cross reference between 3GPP and ETSI identities can be found under <http://webapp.etsi.org/key/queryform.asp>.

Modal verbs terminology

In the present document "**shall**", "**shall not**", "**should**", "**should not**", "**may**", "**need not**", "**will**", "**will not**", "**can**" and "**cannot**" are to be interpreted as described in clause 3.2 of the [ETSI Drafting Rules](#) (Verbal forms for the expression of provisions).

"**must**" and "**must not**" are **NOT** allowed in ETSI deliverables except when used in direct citation.

Contents

Intellectual Property Rights	2
Legal Notice	2
Modal verbs terminology.....	2
Foreword.....	6
1 Scope	8
2 References	9
3 Definitions of terms, symbols and abbreviations	10
3.1 Terms.....	10
3.2 Symbols.....	10
3.3 Abbreviations	10
4 Architecture considerations	10
4.1 High-level architectures	10
4.1.1 High-level 5G System architecture	10
4.1.1.1 5GS Reference Architecture for Supporting Edge Computing	10
4.1.2 High-level architecture for enabling edge applications.....	11
4.2 Edge Computing domain converged charging architecture.....	12
4.2.1 Converged charging architecture for 5GS usage based charging for Edge Computing	12
4.2.2 Converged charging architecture with MnS producer enabled by CEF.....	12
4.2.3 Converged charging architecture with CTF embedded in EES	13
5 Edge Computing charging principles and scenarios	14
5.1 Edge Computing charging principles	14
5.1.1 Overview	14
5.1.2 Charging principles for 5GS usage for Edge Computing	14
5.1.2.1 General.....	14
5.1.2.2 Requirements	15
5.1.2.3 Charging information.....	15
5.1.3 Charging principles for edge enabling infrastructure resource usage	15
5.1.3.1 General.....	15
5.1.3.2 Requirements	15
5.1.3.3 Charging information	15
5.1.3.4 CHF selection.....	16
5.1.4 Charging principles for edge application server deployment.....	16
5.1.4.1 General.....	16
5.1.4.2 Requirements	16
5.1.4.3 Charging information	16
5.1.5 Charging principles for edge enabling services	16
5.1.5.1 General.....	16
5.1.5.2 Requirements	17
5.1.5.3 Charging information.....	17
5.1.5.4 CHF selection.....	17
5.2 Edge Computing converged online and offline charging scenarios	18
5.2.1 Charging scenarios for 5GS usage for Edge Computing	18
5.2.1.1 General.....	18
5.2.2 Charging scenarios for edge enabling infrastructure resource usage	18
5.2.2.1 Basic principles	18
5.2.2.1.1 General	18
5.2.2.1.2 Applicable Triggers in the CEF.....	18
5.2.2.2 Message flows.....	19
5.2.2.2.1 General	19
5.2.2.2.2 Edge enabling infrastructure resource usage charging enabled by CEF.....	19
5.2.2.3 CDR generation.....	21
5.2.2.3.1 Introduction	21
5.2.2.3.2 Triggers for CHF CDR	21

5.2.2.4	Ga record transfer flows.....	21
5.2.3	Charging scenarios for EAS deployment.....	22
5.2.3.1	Basic principles.....	22
5.2.3.1.1	General.....	22
5.2.3.1.2	Applicable Triggers in the CEF.....	22
5.2.3.2	Message flows.....	23
5.2.3.2.1	General.....	23
5.2.3.2.2	EAS deployment charging enabled by CEF.....	23
5.2.3.3	CDR generation.....	24
5.2.3.3.1	Introduction.....	24
5.2.3.3.2	Triggers for CHF CDR.....	24
5.2.3.4	Ga record transfer flows.....	24
5.2.3.5	Bee CDR file transfer.....	24
5.2.4	Charging scenarios for edge enabling services.....	25
5.2.4.1	Basic principles.....	25
5.2.4.1.1	General.....	25
5.2.4.1.2	Applicable triggers in the EES.....	25
5.2.4.2	Message flows.....	27
5.2.4.2.1	General.....	27
5.2.4.2.2	EAS registration charging.....	27
5.2.4.2.3	EAS discovery charging.....	28
5.2.4.2.4	Support to Service Continuity charging.....	30
5.2.4.2.5	Application Client information exposure charging.....	32
5.2.4.2.6	UE location obtaining charging.....	35
5.2.4.2.7	ACR management events subscription charging.....	40
5.2.4.2.8	Session with QoS charging.....	43
5.2.4.3	CDR generation.....	47
5.2.4.3.1	Introduction.....	47
5.2.4.3.2	Triggers for CHF CDR.....	47
5.2.4.4	Ga record transfer flows.....	47
5.2.4.5	Bee CDR file transfer.....	47
6	Definition of Edge Computing charging information.....	47
6.1	Definition of charging information for edge enabling infrastructure resource usage charging.....	47
6.1.1	Data description for edge enabling infrastructure resource usage charging.....	47
6.1.1.1	Message contents.....	47
6.1.1.1.1	General.....	47
6.1.1.1.2	Charging Data Request message.....	48
6.1.1.1.3	Charging data response message.....	49
6.1.1.2	Ga message contents.....	49
6.1.1.3	CDR description on the Bee interface.....	49
6.1.1.3.1	General.....	49
6.1.1.3.2	Edge enabling infrastructure resource usage charging CHF CDR data.....	49
6.1.2	Edge enabling infrastructure resource usage charging specific parameters.....	50
6.1.2.1	Definition of edge enabling infrastructure resource usage charging information.....	50
6.1.2.1.1	General.....	50
6.1.2.1.2	Definition of edge enabling infrastructure resource usage specific charging information.....	51
6.1.2.2	Formal edge enabling infrastructure resource usage charging parameter description.....	51
6.1.2.2.1	Edge enabling infrastructure resource usage CHF CDR parameters.....	51
6.1.2.2.2	Edge enabling infrastructure resource usage resources attributes.....	51
6.1.2.3	Detailed message format for converged charging.....	51
6.1.3	Bindings for edge enabling infrastructure resource usage converged charging.....	53
6.2	Definition of charging information for EAS deployment charging.....	53
6.2.1	Data description for EAS deployment charging.....	53
6.2.1.1	Message contents.....	53
6.2.1.1.1	General.....	53
6.2.1.1.2	Charging Data Request message.....	54
6.2.1.1.3	Charging data response message.....	55
6.2.1.2	Ga message contents.....	55
6.2.1.3	CDR description on the Bee interface.....	55
6.2.1.3.1	General.....	55
6.2.1.3.2	EAS deployment charging CHF CDR data.....	55

6.2.2	EAS deployment charging specific parameters	56
6.2.2.1	Definition of EAS deployment charging information	56
6.2.2.1.1	General	56
6.2.2.1.2	Definition of EAS deployment specific charging information	56
6.2.2.2	Formal EAS deployment charging parameter description	57
6.2.2.2.1	EAS deployment CHF CDR parameters	57
6.2.2.2.2	EAS deployment resources attributes	57
6.2.2.3	Detailed message format for converged charging	57
6.2.3	Bindings for EAS deployment converged charging	58
6.3	Definition of charging information for edge enabling services charging	59
6.3.1	Data description for edge enabling services charging	59
6.3.1.1	Message contents	59
6.3.1.1.1	General	59
6.3.1.1.2	Charging data request message	59
6.3.1.1.3	Charging data response message	60
6.3.1.2	Ga message contents	60
6.3.1.3	CDR description on the Bee interface	60
6.3.1.3.1	General	60
6.3.1.3.2	Edge enabling services charging CHF CDR data	60
6.3.2	Edge enabling services charging specific parameters	61
6.3.2.1	Definition of edge enabling services charging information	61
6.3.2.1.1	General	61
6.3.2.1.2	Definition of direct edge enabling services charging specific charging information	61
6.3.2.1.3	Definition of exposed Edge Enabling Service specific charging information	62
6.3.2.2	Formal edge enabling services charging parameter description	62
6.3.2.2.1	Edge enabling services CHF CDR parameters	62
6.3.2.2.2	Edge enabling services resources attributes	62
6.3.2.3	Detailed message format for converged charging	63
6.3.3	Bindings for edge enabling services converged charging	64
Annex A (informative): Change history		65
History		66

Foreword

This Technical Specification has been produced by the 3rd Generation Partnership Project (3GPP).

The contents of the present document are subject to continuing work within the TSG and may change following formal TSG approval. Should the TSG modify the contents of the present document, it will be re-released by the TSG with an identifying change of release date and an increase in version number as follows:

Version x.y.z

where:

- x the first digit:
 - 1 presented to TSG for information;
 - 2 presented to TSG for approval;
 - 3 or greater indicates TSG approved document under change control.
- y the second digit is incremented for all changes of substance, i.e. technical enhancements, corrections, updates, etc.
- z the third digit is incremented when editorial only changes have been incorporated in the document.

In the present document, modal verbs have the following meanings:

- shall** indicates a mandatory requirement to do something
- shall not** indicates an interdiction (prohibition) to do something

The constructions "shall" and "shall not" are confined to the context of normative provisions, and do not appear in Technical Reports.

The constructions "must" and "must not" are not used as substitutes for "shall" and "shall not". Their use is avoided insofar as possible, and they are not used in a normative context except in a direct citation from an external, referenced, non-3GPP document, or so as to maintain continuity of style when extending or modifying the provisions of such a referenced document.

- should** indicates a recommendation to do something
- should not** indicates a recommendation not to do something
- may** indicates permission to do something
- need not** indicates permission not to do something

The construction "may not" is ambiguous and is not used in normative elements. The unambiguous constructions "might not" or "shall not" are used instead, depending upon the meaning intended.

- can** indicates that something is possible
- cannot** indicates that something is impossible

The constructions "can" and "cannot" are not substitutes for "may" and "need not".

- will** indicates that something is certain or expected to happen as a result of action taken by an agency the behaviour of which is outside the scope of the present document
- will not** indicates that something is certain or expected not to happen as a result of action taken by an agency the behaviour of which is outside the scope of the present document
- might** indicates a likelihood that something will happen as a result of action taken by some agency the behaviour of which is outside the scope of the present document

might not indicates a likelihood that something will not happen as a result of action taken by some agency the behaviour of which is outside the scope of the present document

In addition:

is (or any other verb in the indicative mood) indicates a statement of fact

is not (or any other negative verb in the indicative mood) indicates a statement of fact

The constructions "is" and "is not" do not indicate requirements.

1 Scope

The present document is part of a series of documents that specify charging functionality and charging management in 3GPP networks. The 3GPP core network charging architecture and principles are specified in 3GPP TS 32.240 [2], which provides an umbrella for other charging management TSs that specify:

- the content of the CDRs per domain / subsystem / service (offline charging);
- the content of real-time charging messages per domain / subsystem / service (online charging);
- the functionality of online and offline charging for those domains / subsystems / services;
- the interfaces that are used in the charging framework to transfer the charging information (i.e. CDRs or charging events).

The complete document structure for these TSs is defined in 3GPP TS 32.240 [2].

The present document specifies the converged offline and online charging description for the Edge Computing domain based on the functional stage 2 description in 3GPP TS 23.501 [8] and 3GPP TS 23.558 [9].

Edge computing in 5G environment involves the services or capabilities provided by multiple service providers and entities in the form of following business roles:

- ASP providing edge application service to the subscribers;
- ECSP providing edge enabling infrastructure and edge enabling services to ASP;
- MNO providing 5GS capabilities supporting edge computing.

The present document specifies following charging aspects for Edge Computing:

- Subscriber charging:
 - MNO charges the subscribers for usage of 5GS capabilities supporting edge computing.
- Service-provider charging:
 - MNO charges the industry consumer (e.g. ECSP, ASP) for 5GS capabilities provided to support edge computing in total instead of for each individual subscriber;
 - ECSP charges the ASP for the edge enabling infrastructure and services.

NOTE: In the Edge Computing deployments, there could be scenarios where one or more of the business roles are supported by a single enterprise, i.e. one enterprise may play a single business role or multiple business roles, for instance the enterprise may only play the MNO role, or play both MNO and ECSP roles. There could be various business models between the service providers and the served consumer(s) for edge computing in 5G environment in manifold business modes such as B2C, B2B and B2B2X, for example (but not limited to). The present document does not impose restrictions to any possible business model or deployment scenario for Edge Computing.

2 References

The following documents contain provisions which, through reference in this text, constitute provisions of the present document.

- References are either specific (identified by date of publication, edition number, version number, etc.) or non-specific.
- For a specific reference, subsequent revisions do not apply.
- For a non-specific reference, the latest version applies. In the case of a reference to a 3GPP document (including a GSM document), a non-specific reference implicitly refers to the latest version of that document *in the same Release as the present document*.

- [1] 3GPP TR 21.905: "Vocabulary for 3GPP Specifications".
- [2] 3GPP TS 32.240: "Telecommunication management; Charging management; Charging architecture and principles".
- [3] 3GPP TS 32.298: "Telecommunication management; Charging management; Charging Data Record (CDR) parameter description".
- [4] 3GPP TS 32.297: "Telecommunication management; Charging management; Charging Data Record (CDR) file format and transfer".
- [5] 3GPP TS 32.295: "Telecommunication management; Charging management; Charging Data Record (CDR) transfer".
- [6] 3GPP TS 32.290: "Telecommunication management; Charging management; 5G system; Services, operations and procedures of charging using Service Based Interface (SBI)".
- [7] 3GPP TS 32.291: "Telecommunication management; Charging management; 5G system, charging service; Stage 3".
- [8] 3GPP TS 23.501: "System architecture for the 5G System (5GS)".
- [9] 3GPP TS 23.558: "Architecture for enabling Edge Applications".
- [10] 3GPP TS 23.548 "5G System Enhancements for Edge Computing; Stage 2".
- [11] 3GPP TS 32.255: "Telecommunication management; Charging management; 5G Data connectivity domain charging; stage 2".
- [12] 3GPP TS 28.538: "Management and orchestration; Edge Computing Management".
- [13] 3GPP TS 28.552: "Management and orchestration; 5G performance measurements".
- [14] 3GPP TS 28.550: "Management and orchestration; Performance assurance".
- [15] 3GPP TS 28.532: "Management and orchestration; Generic management services".
- [16] 3GPP TS 32.254: "Telecommunication management; Charging management; Exposure function Northbound Application Program Interfaces (APIs) charging".
- [17] 3GPP TS 29.558: "Enabling Edge Applications; Application Programming Interface (API) specification; Stage 3".

3 Definitions of terms, symbols and abbreviations

3.1 Terms

For the purposes of the present document, the terms given in 3GPP TR 21.905 [1] and the following apply. A term defined in the present document takes precedence over the definition of the same term, if any, in 3GPP TR 21.905 [1].

3.2 Symbols

Void.

3.3 Abbreviations

For the purposes of the present document, the abbreviations given in 3GPP TR 21.905 [1], 3GPP TS 23.501 [8], 3GPP TS 23.558 [9], 3GPP TS 23.548 [10] and the following apply. An abbreviation defined in the present document takes precedence over the definition of the same abbreviation, if any, in 3GPP TR 21.905 [1], 3GPP TS 23.501 [8], 3GPP TS 23.558 [9] and 3GPP TS 23.548 [10].

ASP	Application Service Provider
CEF	Charging Enablement Function
CHF	Charging Function
EAS	Edge Application Server
ECSP	Edge Computing Service Provider
EES	Edge Enabler Server
MNO	Mobile Network Operator
MnS	Management Service
MOI	Managed Object Instance

4 Architecture considerations

4.1 High-level architectures

4.1.1 High-level 5G System architecture

4.1.1.1 5GS Reference Architecture for Supporting Edge Computing

The 5GS architecture for supporting Edge Computing is defined in 3GPP TS 23.548 [10] based on the reference architectures specified in clause 4.2 of 3GPP TS 23.501 [8].

Figure 4.1.1.1-1 depicts 5GS architecture for non-roaming scenario supporting Edge Computing with UL CL/BP.

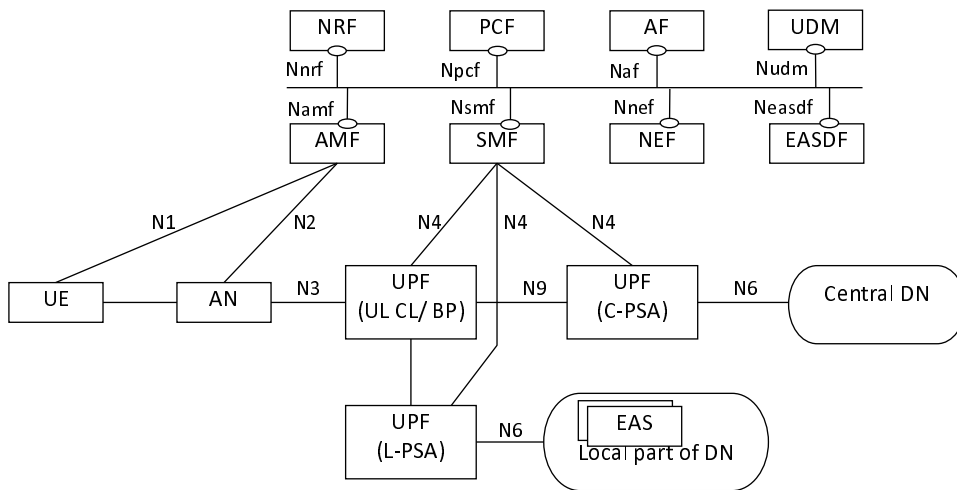

Figure 4.1.1.1-1: 5GS providing access to EAS with UL CL/BP for non-roaming scenario

Figure 4.1.1.1-2 depicts 5GS architecture for non-roaming scenario supporting Edge Computing without UL CL/BP.

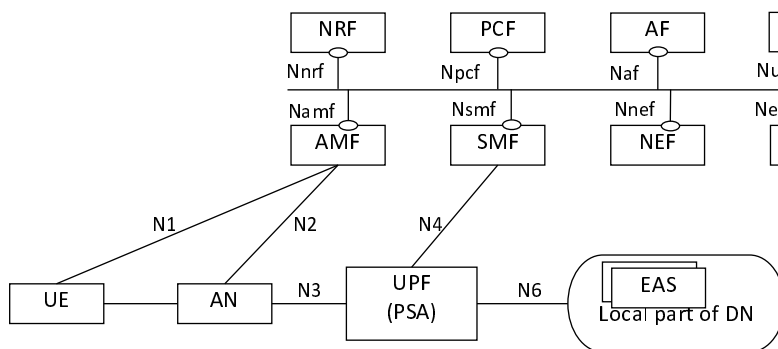

Figure 4.1.1.1-2: 5GS providing access to EAS without UL CL/BP for non-roaming scenario

4.1.2 High-level architecture for enabling edge applications

The following high-level architectures for enabling edge applications are defined in 3GPP TS 23.558 [9]. Figure 4.1.2-1 depicts the service based representation of architecture for enabling edge applications.

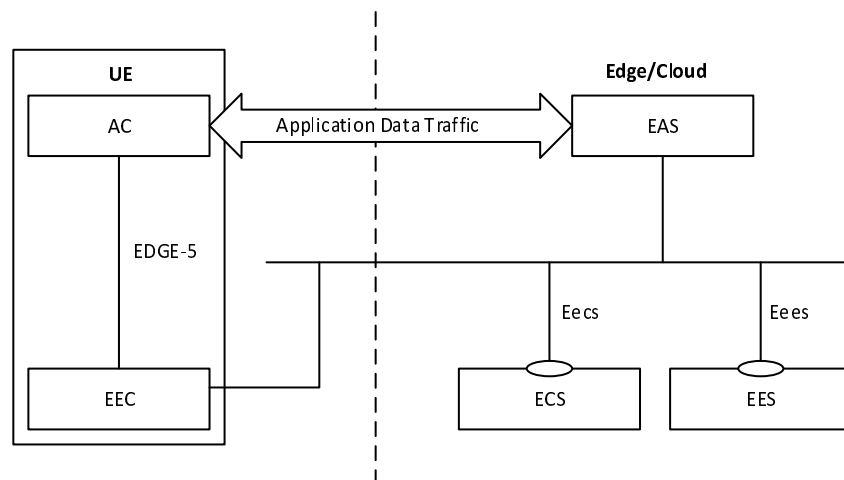

Figure 4.1.2-1: Architecture for enabling edge applications - service based representation

Figure 4.1.2-2 depicts the service-based representation for utilization of the 5GS network services.

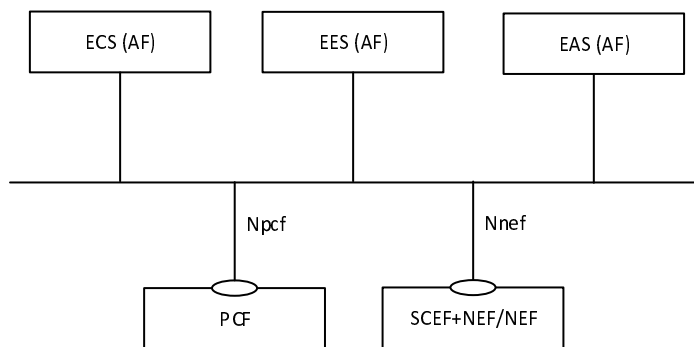

Figure 4.1.2-2: Utilization of 5GS network services based on the 5GS SBA - service based representation

Figure 4.1.2-3 depicts the reference point representation of the architecture for edge enabling applications.

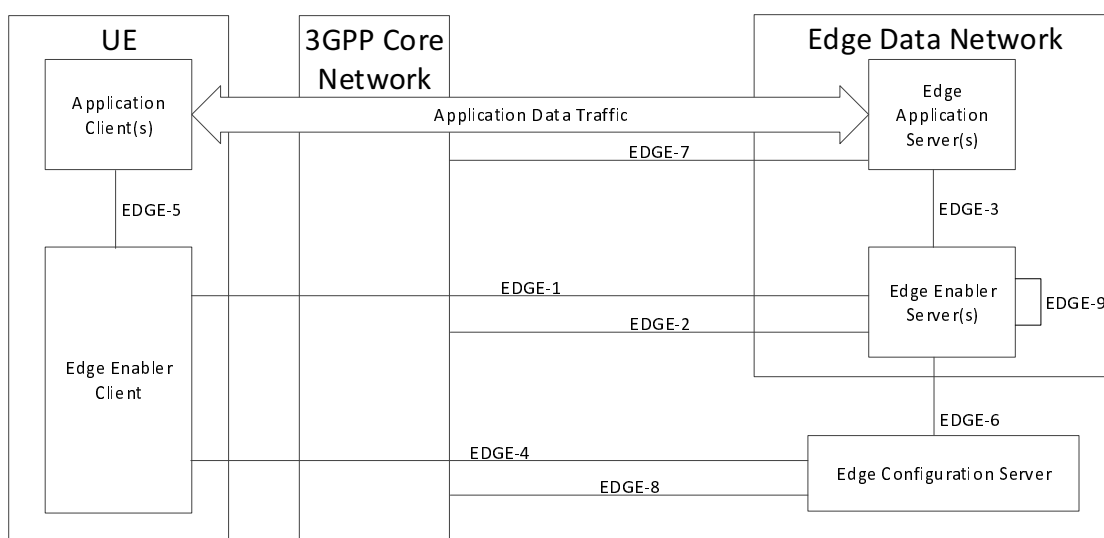

Figure 4.1.2-3: Architecture for enabling edge applications - reference points representation

4.2 Edge Computing domain converged charging architecture

4.2.1 Converged charging architecture for 5GS usage based charging for Edge Computing

For 5GS usage based charging for Edge Computing, the 5G data connectivity domain converged charging architecture defined in 3GPP TS 32.255 [11] is applied.

4.2.2 Converged charging architecture with MnS producer enabled by CEF

The CEF consumes the MnS from the MnS producer for EAS management (see 3GPP TS 28.538 [12]), and determines the occurrence of charging events towards to the CHF for converged charging processing. The CDRs generation is performed by the CHF acting as a CDF, which transfers them to the CGF. Finally, the CGF creates CDR files and forwards them to the BD.

If the CGF is external, the CHF acting as a CDF, forwards the CDRs to the CGF across the Ga interface.
 If the CGF is integrated, there is only one internal interface between the CHF and the CGF. In this case, the relationship between CHF and CGF is 1:1. An integrated CGF may support the Ga interface from other CDFs.

When an external CGF is used, this CGF may also be used by other, i.e. non-5GCS, network elements, according to network design and operator decision. It should be noted that the CGF may also be an integrated component of the BD - in this case, the Bd interface does not exist and is replaced by a proprietary solution internal to the BD.

Figure 4.2.2-1 depicts the architectural options for converged charging with support of MnS producer.

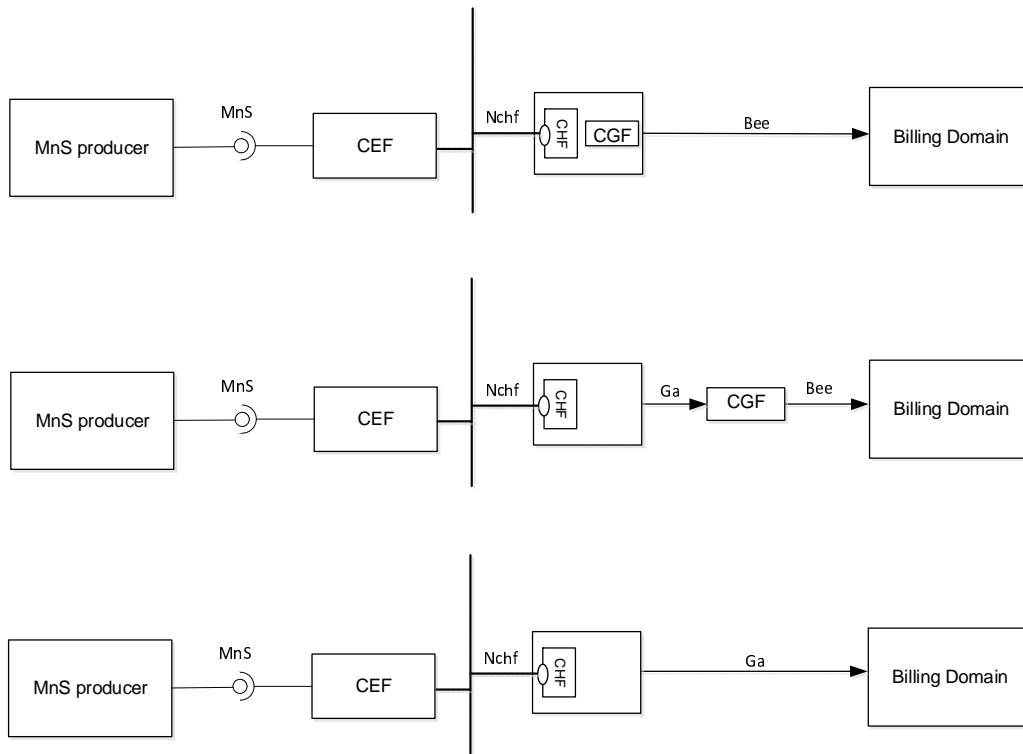

Figure 4.2.2-1: Converged charging architecture with MnS producer enabled by CEF

4.2.3 Converged charging architecture with CTF embedded in EES

The EES embedding the CTF, generates charging events towards the CHF for edge enabling services usage.

Figure 4.2.3-1 depicts the architectural options for converged charging of edge enabling services.

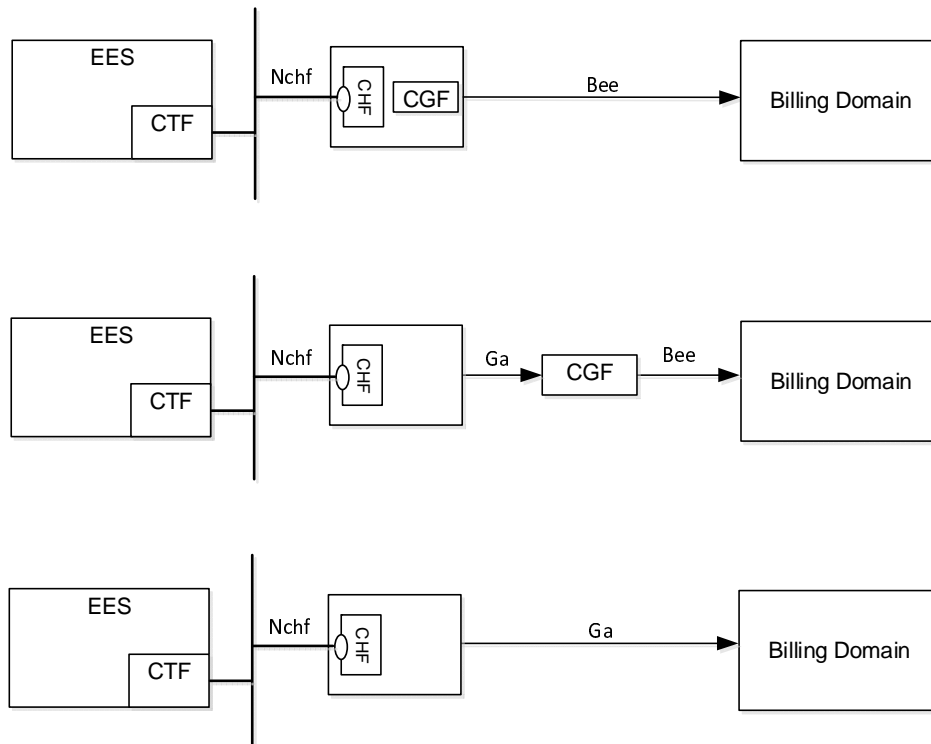

Figure 4.2.3-1: Converged charging architecture with CTF embedded in EES

5 Edge Computing charging principles and scenarios

5.1 Edge Computing charging principles

5.1.1 Overview

The charging for Edge Computing domain includes charging for the following aspects:

- 5GS usage for Edge Computing (in clause 5.1.2);
- Edge enabling infrastructure resource usage (in clause 5.1.3);
- Edge application server deployment (in clause 5.1.4); and
- Edge enabling services usage (in clause 5.1.5).

5.1.2 Charging principles for 5GS usage for Edge Computing

5.1.2.1 General

The charging for 5GS usage for Edge Computing is based on the charging functions and principles for 5G data connectivity charging specified in 3GPP TS 32.255 [11].

And, the charging information for PDU sessions and service data flows are correlated to each edge application.

The charging functions for 5GS usage for Edge Computing supports both subscriber based charging and inter-provider based charging.

The charging for 5GS usage for each application should be able to take the monitored QoS (e2e packet delay in 5GS, see 3GPP TS 23.501 [8]) into account.

5.1.2.2 Requirements

The following are high-level charging requirements specific to the charging for 5GS usage for Edge Computing, derived from the requirements in 3GPP TS 23.501 [8], 3GPP TS 23.548 [10], and based on the 5G data connectivity charging requirements specified in 3GPP TS 32.255 [11]:

- The SMF shall be able to provide the information for correlating the PDU session and service data flow to the edge application for charging.
- The SMF should be able to report the monitored QoS result (e2e packet delay in 5GS, see 3GPP TS 23.501 [8]) along with the 5GS usage for each edge application.

5.1.2.3 Charging information

The charging information for 5GS usage for Edge Computing is collected for each UE and each edge application by the SMFs, and are specified in 3GPP TS 32.255 [11].

5.1.3 Charging principles for edge enabling infrastructure resource usage

5.1.3.1 General

In the present specification, the charging is specified for the usage of edge enabling infrastructure resources in the EDN of an ECSP to run the virtualized EAS (i.e. EAS is implemented as VNF) provided by an ASP.

The charging for edge enabling infrastructure resources usage, is based on the MnS(s) for performance assurance of Edge Computing specified in 3GPP TS 28.538 [12], including following resources usage for EAS:

- mean virtual CPU usage;
- mean virtual memory usage;
- mean virtual disk usage;
- data volumes.

The time window during which the charging for edge enabling infrastructure resource usage needs to be enabled, and the criteria (e.g. thresholds) for triggering the charging may be locally configured to CEF, and cannot be controlled by CHF.

5.1.3.2 Requirements

The following are high-level charging requirements specific to the edge enabling infrastructure resources charging:

- The CEF shall be able to consume the MnS (see 3GPP TS 28.538 [12]) to collect the following performance measurements about the usage of enabling infrastructure resources that are supporting to run the virtualized EAS, and enable converged charging when the CEF has fetched the performance data file containing these measurements or the CEF receives the performance data of these measurements by the reportStreamData operation from MnS producer:
 - mean virtual CPU usage (see 3GPP TS 28.552 [13]);
 - mean virtual memory usage (see 3GPP TS 28.552 [13]);
 - mean virtual disk usage (see 3GPP TS 28.552 [13]);
 - data volumes (see 3GPP TS 28.552 [13]).

5.1.3.3 Charging information

Charging information for edge enabling infrastructure resources usage charging is collected for each EAS by the CEF from the MnS, with the information identifying the EDN where the edge enabling infrastructure resources are allocated and the information indicating the collection period of the measurements related to the edge enabling infrastructure resources usage.

5.1.3.4 CHF selection

The CHF Address(es) selection by the CEF is done during the EAS deployment process based on the following options:

- NRF based discovery.
- CEF locally provisioned charging characteristics.

The priority order between these options depends on Operator's policies.

Once selected, these CHF Address(es) shall be used as long as the EAS is deployed in the EDN.

5.1.4 Charging principles for edge application server deployment

5.1.4.1 General

In the present specification, the charging is specified for deployment of virtualized EAS in the EDN by an ECSP for an ASP.

The charging for edge application server deployment, is based on the MnS(s) for LCM (LifeCycle Management) of Edge Computing specified in 3GPP TS 28.538 [12], including following deployment activities for EAS:

- EAS instantiation;
- EAS upgrade;
- EAS termination.

5.1.4.2 Requirements

The following are high-level charging requirements specific to the EAS deployment charging:

- The CEF shall be able to consume the MnS (see 3GPP TS 28.538 [12]) to receive the notifications about EAS deployment, and enable charging for the EAS deployment which includes:
 - EAS instantiation (see 3GPP TS 28.538 [12]);
 - EAS upgrade (see 3GPP TS 28.538 [12]);
 - EAS termination (see 3GPP TS 28.538 [12]).

5.1.4.3 Charging information

Charging information for EAS deployment charging is collected for each EAS by the CEF from the MnS.

The CEF collects the following charging information for converged charging of EAS deployment charging:

- EAS deployment requirements: the requirements for EAS deployment (e.g. the topological or geographical service areas, software image information), see 3GPP TS [28.538](#) [12];
- EAS: the charging information identifying the EAS which the LCM is for;
- EDN: the charging information identifying the EDN where the EAS is/was deployed;
- LCM start time: the charging information indicating the start time of the LCM process;
- LCM end time: the charging information indicating the end time of the LCM process.

5.1.5 Charging principles for edge enabling services

5.1.5.1 General

In the present specification, the charging is specified for edge enabling services provided by an ECSP to an ASP.

The charging for edge enabling services, is based on the edge application enabling functionalities specified in 3GPP TS 23.558 [9], including the services directly provided by ECSP to ASP, and the 3GPP 5GC NF services exposed by ECSP to ASP:

- Edge enabling services directly provided by ECSP to ASP:
 - EAS registration;
 - EAS discovery;
 - Support to Service Continuity;
 - Application Client information subscription/notification;
- Edge enabling services exposed by ECSP to ASP:
 - Obtaining UE location;
 - ACR management events subscription;
 - Session with QoS.

5.1.5.2 Requirements

The following are high-level charging requirements specific to the edge enabling services charging:

- The EES shall support converged charging for edge enabling services using service based interface.
- The EES shall support converged charging per EAS registration.
- The EES shall support converged charging per EAS discovery.
- The EES shall support converged charging per Service Continuity support.
- The EES shall support converged charging per Application Client information exposure.
- The EES shall support converged charging per UE location Obtaining.
- The EES shall support converged charging ACR management events subscription.
- The EES shall support converged charging per Session with QoS.

5.1.5.3 Charging information

Charging information for edge enabling services charging is collected for each EAS by EES(es).

The EES collects the following charging information for converged charging of edge enabling services charging:

- EAS: the charging information identifying the EAS for which the edge enabling service is provided;
- EDN: the charging information identifying the EDN where the EAS is/was deployed;
- EES: the charging information indicating the EES which triggers the charging;
- Triggering event: the triggering events of charging for edge enabling services;
- Triggering event specific information: the charging information specific to the triggering event of charging for edge enabling services.

5.1.5.4 CHF selection

The CHF Address(es) selection by the CEF is done during the EAS deployment process based on the following options:

- NRF based discovery.
- CEF locally provisioned charging characteristics.

The priority order between these options depends on Operator's policies.

Once selected, these CHF Address(es) shall be used as long as the EAS is deployed in the EDN.

5.2 Edge Computing converged online and offline charging scenarios

5.2.1 Charging scenarios for 5GS usage for Edge Computing

5.2.1.1 General

The scenarios, principles, message flows, CDR generation, Ga record transfer flows and Bd CDR file transfer for converged online and offline charging for 5G data connectivity specified in 3GPP TS 32.255 [11] are also applied to 5GS usage charging for Edge Computing.

In addition, the SMF provides the information for correlating the PDU session and service data flow to the edge application for charging, and optionally reports the monitored QoS result (e2e packet delay obtained by QoS monitoring in 5GS, see 3GPP TS 23.501 [8]) along with the 5GS usage for charging.

5.2.2 Charging scenarios for edge enabling infrastructure resource usage

5.2.2.1 Basic principles

5.2.2.1.1 General

Converged charging for edge enabling infrastructure resources usage may be performed by the CEF interacting with CHF using Nchf specified in 3GPP TS 32.290 [6] and 3GPP TS 32.291 [7]. In order to provide the data required for the management activities outlined in 3GPP TS 32.240 [1] (Credit-Control, accounting, billing, statistics, etc.), the CEF shall be able to perform converged charging for each of the following:

- virtual CPU usage (see VR.VCpuUsageMean in clause 5.7.1.1.1 of 3GPP TS 28.552 [13]);
- virtual memory usage (see VR.VMemoryUsageMean in clause 5.7.1.2.1 of 3GPP TS 28.552 [13]);
- virtual disk usage (see VR.VDiskUsageMean in clause 5.7.1.3.1 in 3GPP TS 28.552 [13]);
- data volumes (see DataVolum.InBytesEAS in clause 5.7.2.1 and DataVolum.OutBytesEAS in clause 5.7.2.2 of 3GPP TS 28.552 [13]).

The CEF shall request the MnS producer to create the measurement job for collecting the performance measurements on the usage of edge infrastructure resource for supporting the EAS.

Once the performance measurements on the usage of edge infrastructure resource are received or obtained, the CEF shall be able to report the corresponding charging events to CHF for CDR generation.

A detailed formal description of the converged charging parameters defined in the present document is to be found in 3GPP TS 32.291 [7].

A detailed formal description of the CDR parameters defined in the present document is to be found in 3GPP TS 32.298 [3].

5.2.2.1.2 Applicable Triggers in the CEF

When a charging event is issued towards the CHF by the CEF, it includes details of charging information, such as EAS identifier (e.g. EAS ID, see 3GPP TS 23.558 [9]).

Each trigger condition (i.e. chargeable event) defined for edge enabling infrastructure resource usage charging, is specified with the associated behaviour when they are met.

The immediate report is applied to the chargeable events for edge enabling infrastructure resource usage charging, i.e. the chargeable events for which. When the CEF consumes the MnS to create measurement job, the converged charging is activated. When the CEF receives or gets the performance data report containing the usage of edge enabling infrastructure resource, the CEF invokes a Charging Data Request to report the charging data based on PEC to CHF.

The charging for edge enabling infrastructure resources usage cannot be enabled and disabled by CHF.

Table 5.2.2.1.2-1 summarizes the set of default trigger conditions and their category which shall be supported by the CEF when charging is active for the edge enabling infrastructure resource usage charging.

Table 5.2.2.1.2-1: Default Trigger conditions in CEF

Trigger Conditions	Trigger level	Default category	CHF allowed to change category	CHF allowed to enable and disable	Message when "immediate reporting" category
Edge enabling infrastructure resource usage reporting					
CEF has fetched the performance data file containing the measurements for the usage of edge enabling infrastructure resources, based on the <code>notifyFileReady</code> notification from the MnS producer, see 3GPP TS 28.532 [15]	-	Immediate	Not Applicable	No	PEC: Charging Data Request [Event]
CEF receives the performance data containing the measurements for the usage of edge enabling infrastructure resources, by the <code>reportStreamData</code> operation from MnS producer, see 3GPP TS 28.532 [15]	-	Immediate	Not Applicable	No	PEC: Charging Data Request [Event]

5.2.2.2 Message flows

5.2.2.2.1 General

The flows in the present document specify the interactions between the MnS producer, CEF and CHF for edge enabling infrastructure resource usage converged charging.

The interaction between MnS producer and CEF is based on MnS procedures for performance assurance specified in 3GPP TS 28.538 [12] and 3GPP TS 28.550 [14].

This interaction between CEF and CHF is based on Charging Data Request /Response specified in 3GPP TS 32.290 [6].

5.2.2.2.2 Edge enabling infrastructure resource usage charging enabled by CEF

Figure 5.2.2.2.2-1 describes an edge enabling infrastructure resource usage charging message flows in PEC, based on the converged charging architecture with MnS producer enabled by CEF (see clause 4.2.2).

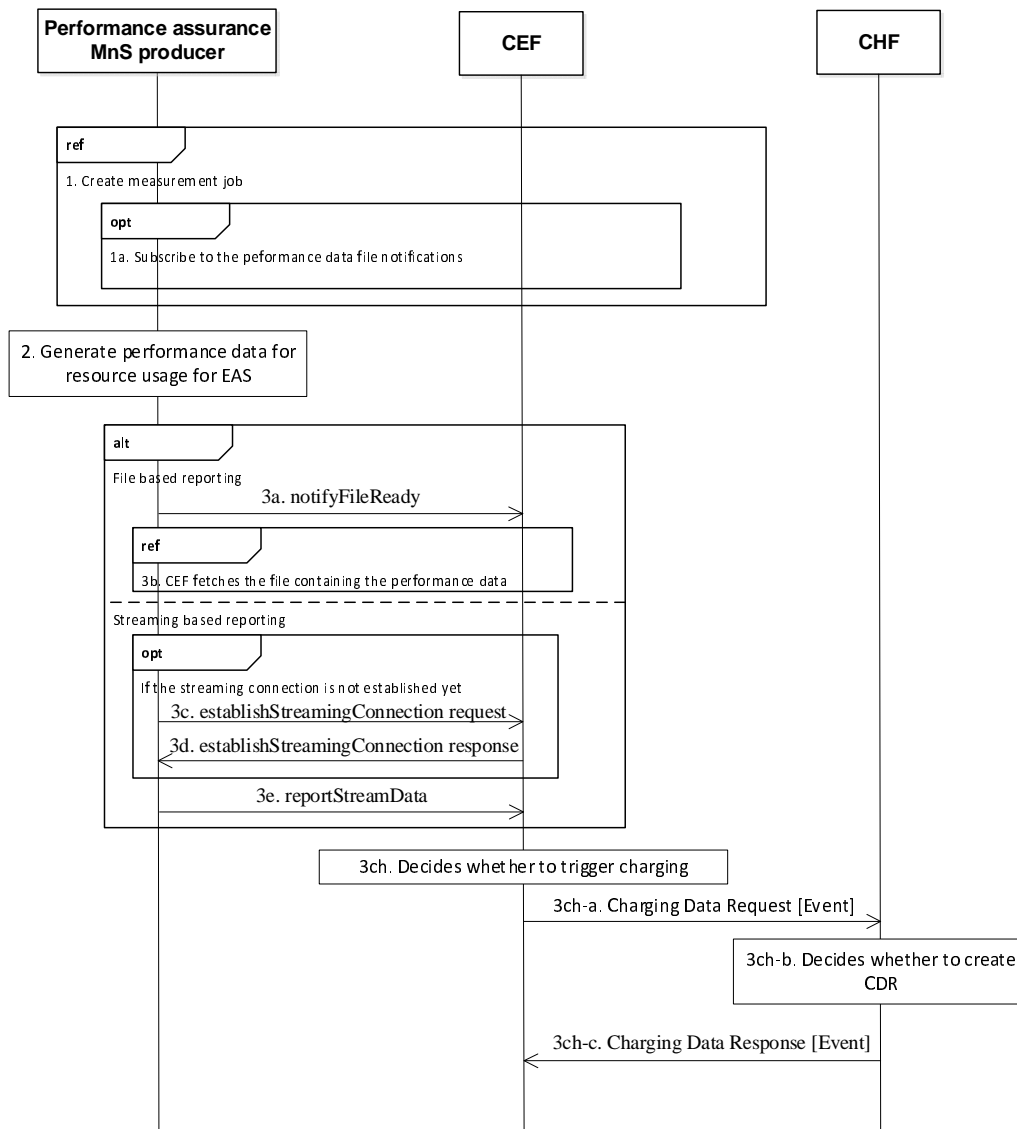

Figure 5.2.2.2-1: Edge enabling infrastructure resource usage charging - PEC

- 1) **Create measurement job:** The CEF creates measurement job to collect the performance measurements related to Virtualized Resource (VR) usage for EAS to performance assurance MnS producer (see 3GPP TS 28.538 [12] and 3GPP TS 28.550 [14]). The performance measurements can be one or more of the following:
 - mean virtual CPU usage (see VR.VCpuUsageMean in clause 5.7.1.1.1 of 3GPP TS 28.552 [13]);
 - mean virtual memory usage (see VR.VMemoryUsageMean in clause 5.7.1.2.1 of 3GPP TS 28.552 [13]);
 - mean virtual disk usage (see VR.VDiskUsageMean in clause 5.7.1.3.1 in 3GPP TS 28.552 [13]);
 - incoming data volume (see DataVolum.InBytesEAS in clause 5.7.2.1 of 3GPP TS 28.552 [13]);
 - outgoing data volume (see DataVolum.OutBytesEAS in clause 5.7.2.2 of 3GPP TS 28.552 [13]).
- 1a) **Subscribe to performance data file notifications:** If file reporting method is chosen for the measurement job, the CEF subscribes to the performance data file notifications, see 3GPP TS 28.532 [15].
- 2) **Generate performance measurements for resource usage for EAS:** performance assurance MnS producer generates the performance measurements according to the measurement job.
- 3) **Performance data report to CEF:** the performance assurance MnS producer reports the performance data to the CEF according to the reporting method selected by the CEF for the measurement job.

If the file data reporting method is selected:

- 3a) The performance data are reported by a `notifyFileReady` notification (see 3GPP TS 28.532 [15]);
- 3b) CEF fetches the file containing the performance data.

If the streaming data reporting method is selected:

- 3c) and 3d) The performance assurance MnS producer establishes the streaming connection with the CEF if the connection has not been established (see 3GPP TS 28.532 [15]);
- 3e) The performance data are reported by the `reportStreamData` operation (see 3GPP TS 28.532 [15]).

- 3ch-a) Decide whether to trigger the charging:** CEF decides whether to trigger the charging. If charging is triggered.
- 3ch-b) Charging Data Request [Event]:** The CEF generates charging data for the collected resource usage and sends the charging data request for the CHF to process the related charging data for CDR generation purpose.
- 3ch-c) Create CDR:** the CHF stores received information and decides whether to store the information for future aggregation or to create a CDR related to the event.
- 3ch-d) Charging Data Response [Event]:** The CHF informs the CEF on the result of the request.

5.2.2.3 CDR generation

5.2.2.3.1 Introduction

The CHF CDRs for edge enabling infrastructure resource usage charging are generated by the CHF to collect charging information that they subsequently transfer to the Charging Gateway Function (CGF).

The following clauses describe in detail the conditions for generating the CHF CDR.

5.2.2.3.2 Triggers for CHF CDR

5.2.2.3.2.1 General

An edge enabling infrastructure resource usage charging CHF CDR is used to collect charging information related to edge enabling infrastructure resource usage chargeable events.

5.2.2.3.2.2 Triggers for CHF CDR generation

The CHF decides whether to create a CDR for each received Charging Data Request [Event].

5.2.2.4 Ga record transfer flows

For Ga protocol application refer to 3GPP TS 32.295 [5].

5.2.3 Charging scenarios for EAS deployment

5.2.3.1 Basic principles

5.2.3.1.1 General

Converged charging for EAS deployment may be performed by the CEF interacting with CHF using Nchf specified in 3GPP TS 32.290 [6] and 3GPP TS 32.291 [7]. In order to provide the data required for the management activities outlined in 3GPP TS 32.240 [1] (Credit-Control, accounting, billing, statistics etc.), the CEF shall be able to perform converged charging for each of the following:

- EAS deployment (see clause 5.1.2 3GPP TS 28.538 [12]);
- EAS modification (see clause 5.1.5 3GPP TS 28.538 [12]);
- EAS termination (see clause 5.1.3 3GPP TS 28.538 [12]).

The CEF shall subscribe to the notifications from the provisioning MnS producer for EAS LCM.

Once the notification about EAS LCM is received, the CEF shall be able to report the corresponding charging events to CHF for CDR generation.

A detailed formal description of the converged charging parameters defined in the present document is to be found in 3GPP TS 32.291 [7].

A detailed formal description of the CDR parameters defined in the present document is to be found in 3GPP TS 32.298 [3].

5.2.3.1.2 Applicable Triggers in the CEF

When a charging event is issued towards the CHF by the CEF, it includes details of charging information, such as EAS identifier (e.g. EAS ID, see 3GPP TS 23.558 [9]).

Each trigger condition (i.e. chargeable event) defined for EAS deployment charging, is specified with the associated behaviour when they are met.

The immediate report is applied to the chargeable events for EAS deployment charging, i.e. the chargeable events for which, when occurring, the current counts are closed and sent together with the charging data generated by the CEF towards the CHF in a Charging Data Request. New counts are started by the CEF.

When the CEF subscribes to the notifications about EAS LCM from the MnS producer, the converged charging is activated. When the CEF receives notifications about EAS LCM, the CEF invokes a Charging Data Request the CHF to report the EAS LCM activity as PEC.

Table 5.2.3.1.2-1 summarizes the set of default trigger conditions and their category which shall be supported by the CEF when charging is active for the EAS deployment charging.

Table 5.2.3.1.2-1: Default Trigger conditions in CEF

Trigger Conditions	Trigger level	Default category	CHF allowed to change category	CHF allowed to enable and disable	Message when "immediate reporting" category
EAS deployment charging					
CEF receives the notifyMOICreation notification for an MOI of EASFunction from MnS producer, see 3GPP TS 28.532 [15].	-	Immediate	Not Applicable	No	PEC: Charging Data Request [Event]
CEF receives the notifyMOIAttributeValueChanges notification for an MOI of EASFunction from MnS producer, see 3GPP TS 28.532 [15].	-	Immediate	Not Applicable	No	PEC: Charging Data Request [Event]
CEF receives the notifyMOIDeletion notification for an MOI of EASFunction from MnS producer, see 3GPP TS 28.532 [15].	-	Immediate	Not Applicable	No	PEC: Charging Data Request [Event]

5.2.3.2 Message flows

5.2.3.2.1 General

The flows in the present document specify the interactions between the MnS producer, CEF and CHF for EAS deployment converged charging.

The interaction between MnS producer and CEF is based on MnS for subscribing to and reporting notifications specified in 3GPP TS 28.532 [15] and 3GPP TS 28.538 [12].

This interaction between CEF and CHF is based on Charging Data Request /Response specified in 3GPP TS 32.290 [6].

5.2.3.2.2 EAS deployment charging enabled by CEF

Figure 5.2.3.2.2-1 describes an EAS deployment charging message flows in PEC, based on the converged charging architecture with MnS producer enabled by CEF (see clause 4.2.2).

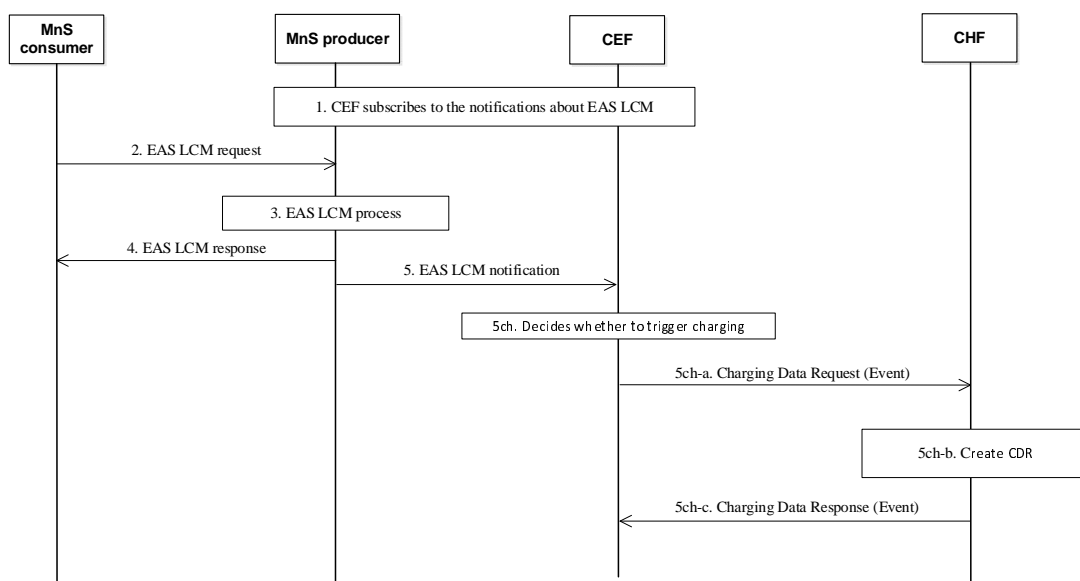

Figure 5.2.3.2.2-1: EAS deployment charging - PEC

- 1) **CEF subscribes to the notifications about EAS LCM from the MnS:** The CEF consumes the provisioning MnS (see 3GPP TS 28.532 [15]) to subscribe to the notifications about EAS LCM, including `notifyMOICreation`, `notifyMOIAttributeValueChanges`, and `notifyMOIDeletion`.
- 2) **EAS LCM request:** The MnS consumer sends the EAS LCM request to the MnS producer, the EAS LCM request is done via `createMOI`, `modifyMOIAttributes` or `deleteMOI` operation (see 3GPP TS 28.532 [15]) for the `EASFunction` IOC (see 3GPP TS 28.538 [12]).
- 3) **EAS LCM process:** The MnS producer processes and executes the EAS LCM according to the request (e.g. instantiation, upgrade, deletion).
- 4) **EAS LCM response:** The MnS producer sends the EAS LCM result to the MnS consumer.
- 5) **EAS LCM notification:** The MnS producer sends the EAS LCM notification (i.e. `notifyMOICreation`, `notifyMOIAttributeValueChanges`, or `notifyMOIDeletion`) to the CEF:
 - 5ch-a) **Charging Data Request [Event]:** The CEF generates charging data related to the EAS LCM notification and sends the charging data request.
 - 5ch-b) **Create CDR:** The CHF stores received information and create a CDR related to the event.
 - 5ch-c) **Charging Data Response [Event]:** The CHF informs the CEF on the result of the request.

5.2.3.3 CDR generation

5.2.3.3.1 Introduction

The CHF CDRs for EAS deployment charging are generated by the CHF to collect charging information that they subsequently transfer to the Charging Gateway Function (CGF).

The following clauses describe in detail the conditions for generating the CHF CDR.

5.2.3.3.2 Triggers for CHF CDR

5.2.3.3.2.1 General

An EAS deployment charging CHF CDR is used to collect charging information related to EAS deployment chargeable events.

5.2.3.3.2.2 Triggers for CHF CDR generation

A CHF CDR shall be generated by the CHF for each received Charging Data Request [Event].

5.2.3.4 Ga record transfer flows

For Ga protocol application refer to 3GPP TS 32.295 [5].

5.2.3.5 Bee CDR file transfer

For Bee protocol application refer to 3GPP TS 32.297 [4].

5.2.4 Charging scenarios for edge enabling services

5.2.4.1 Basic principles

5.2.4.1.1 General

Converged charging for edge enabling services, when activated may be performed by the EES interacting with CHF using Nchf specified in 3GPP TS 32.290 [6] and 3GPP TS 32.291 [7]. In order to provide the data required for the management activities outlined in 3GPP TS 32.240 [1] (Credit-Control, accounting, billing, statistics, etc.), the EES shall be able to perform converged charging for each of the following:

- Edge enabling services directly provided by ECSP to ASP (see 3GPP TS 23.558 [9]):
 - EAS registration;
 - EAS discovery;
 - Support to Service Continuity;
 - Application Client information exposure;
- Edge enabling services exposed by ECSP to ASP (see 3GPP TS 23.558 [9]):
 - Obtaining UE location;
 - ACR management events subscription;
 - Session with QoS.

The EES shall be able to perform converged charging by interacting with CHF, for charging data related to the events mentioned above. The Charging Data Request and Charging Data Response are exchanged between the EES and the CHF, based on either IEC or PEC scenarios as specified in 3GPP TS 32.290 [6].

The contents and purpose of each charging event that triggers interaction with CHF, as well as the chargeable events that trigger them, are described in the following clauses.

A detailed formal description of the converged charging parameters defined in the present document is to be found in 3GPP TS 32.291 [7].

A detailed formal description of the CDR parameters defined in the present document is to be found in 3GPP TS 32.298 [3].

NOTE: How to avoid double triggering or support correlation of charging events from both NEF and EES is not addressed in the present document.

5.2.4.1.2 Applicable triggers in the EES

When a charging event is issued towards the CHF by the EES, it includes details of charging information, such as EAS identifier (e.g. EAS ID, see 3GPP TS 23.558 [9]).

Each trigger condition (i.e. chargeable event) defined for edge enabling services charging, is specified with the associated behaviour when they are met.

The immediate report is applied to the chargeable events for edge enabling services charging, i.e. the chargeable events for which, when occurring, the current counts are closed and sent together with the charging data generated by the EES towards the CHF in a Charging Data Request. New counts are started by the EES.

Table 5.2.4.1.2-1 summarizes the set of default trigger conditions and their category which shall be supported by the EES when charging is active for the edge enabling services charging.

Table 5.2.4.1.2-1: Default Trigger conditions in EES

Trigger Conditions	Trigger level	Default category	CHF allowed to change category	CHF allowed to enable and disable	Message when "immediate reporting" category
Charging for edge enabling services directly provided by EES					
EAS registration request	-	Immediate	Not Applicable	Yes	IEC: Charging Data Request [Event]
EAS registration response	-	Immediate	Not Applicable	Yes	PEC: Charging Data Request [Event]
EAS discovery request		Immediate	Not Applicable	Yes	IEC: Charging Data Request [Event]
EAS discovery response		Immediate	Not Applicable	Yes	PEC: Charging Data Request [Event]
ACR request	-	Immediate	Not Applicable	Yes	IEC: Charging Data Request [Event]
ACR response	-	Immediate	Not Applicable	Yes	PEC: Charging Data Request [Event]
ACR status update request	-	Immediate	Not Applicable	Yes	IEC: Charging Data Request [Event]
ACR status update response	-	Immediate	Not Applicable	Yes	PEC: Charging Data Request [Event]
AC information subscribe request		Immediate	Not Applicable	Yes	IEC: Charging Data Request [Event]
AC information subscribe response		Immediate	Not Applicable	Yes	PEC: Charging Data Request [Event]
AC information subscription update request		Immediate	Not Applicable	Yes	IEC: Charging Data Request [Event]
AC information subscription update response		Immediate	Not Applicable	Yes	PEC: Charging Data Request [Event]
AC information notification		Immediate	Not Applicable	Yes	PEC: Charging Data Request [Event]
Charging for edge enabling services exposed by EES					
UE location request	-	Immediate	Not Applicable	Yes	IEC: Charging Data Request [Event]
UE location response	-	Immediate	Not Applicable	Yes	PEC: Charging Data Request [Event]
UE location subscribe request		Immediate	Not Applicable	Yes	IEC: Charging Data Request [Event]
UE location subscribe response		Immediate	Not Applicable	Yes	PEC: Charging Data Request [Event]
UE location subscription update request		Immediate	Not Applicable	Yes	IEC: Charging Data Request [Event]
UE location subscription update response		Immediate	Not Applicable	Yes	PEC: Charging Data Request [Event]
UE location notification	-	Immediate	Not Applicable	Yes	PEC: Charging Data Request [Event]
ACR management event subscribe request		Immediate	Not Applicable	Yes	IEC: Charging Data Request [Event]
ACR management event subscribe response		Immediate	Not Applicable	Yes	PEC: Charging Data Request [Event]
ACR management event subscription update request		Immediate	Not Applicable	Yes	IEC: Charging Data Request [Event]
ACR management event subscription update response		Immediate	Not Applicable	Yes	PEC: Charging Data Request [Event]
Session with QoS create request		Immediate	Not Applicable	Yes	IEC: Charging Data Request [Event]
Session with QoS create response		Immediate	Not Applicable	Yes	PEC: Charging Data Request [Event]
Session with QoS update request		Immediate	Not Applicable	Yes	IEC: Charging Data Request [Event]
Session with QoS update response		Immediate	Not Applicable	Yes	PEC: Charging Data Request [Event]
Session with QoS event notification		Immediate	Not Applicable	Yes	PEC: Charging Data Request [Event]

5.2.4.2 Message flows

5.2.4.2.1 General

The flows in the present document specify the interactions between the EES and CHF for edge enabling services converged charging, based on the procedures and flows specified in 3GPP TS 23.558 [9].

This interaction is based on Charging Data Request /Response specified in 3GPP TS 32.290 [6], exchanged between the EES embedding the CTF and the CHF, in compliance with the converged charging architecture defined in clause 4.2.3.

5.2.4.2.2 EAS registration charging

5.2.4.2.2.1 General

The clauses below describe the EAS registration charging message flows.

For EAS registration charging, the following scenarios specified in 3GPP TS 32.290 [6] are supported:

- IEC;
- PEC.

5.2.4.2.2.2 EAS registration charging - IEC

Figure 5.2.4.2.2.2-1 describes an EAS registration charging message flow in IEC charging.

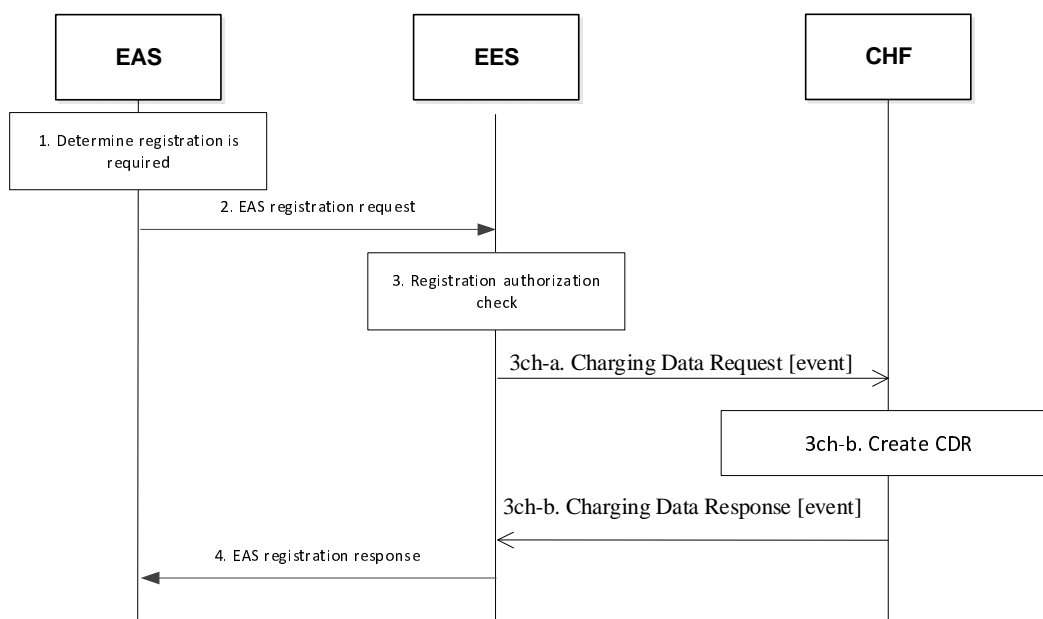

Figure 5.2.4.2.2.2-1: Charging for EAS registration - IEC

- 1) The EAS determines that registration to the EES is needed (e.g. the EAS is instantiated and started up).
- 2) The EAS sends an EAS registration request to the EES. The request shall include the EAS profile and may include proposed expiration time for the registration.
- 3) The EES performs an authorization check to verify whether the EAS has the authorization to register on the EES. If authorized:
 - 3ch-a) Charging Data Request [Event]:** The EES generates charging data related to the EAS Registration request and sends the charging data request for the CHF to process the related charging data for CDR generation purpose.
 - 3ch-b) Create CDR:** The CHF stores received information and creates a CDR related to the event.

3ch-c) Charging Data Response [Event]: The CHF informs the EES on the result of the request.

4) The EES sends EAS response (see 3GPP TS 23.558 [9]) to the EAS.

5.2.4.2.2.3 EAS registration charging - PEC

Figure 5.2.4.2.2.3-1 describes an EAS registration charging message flow in PEC charging.

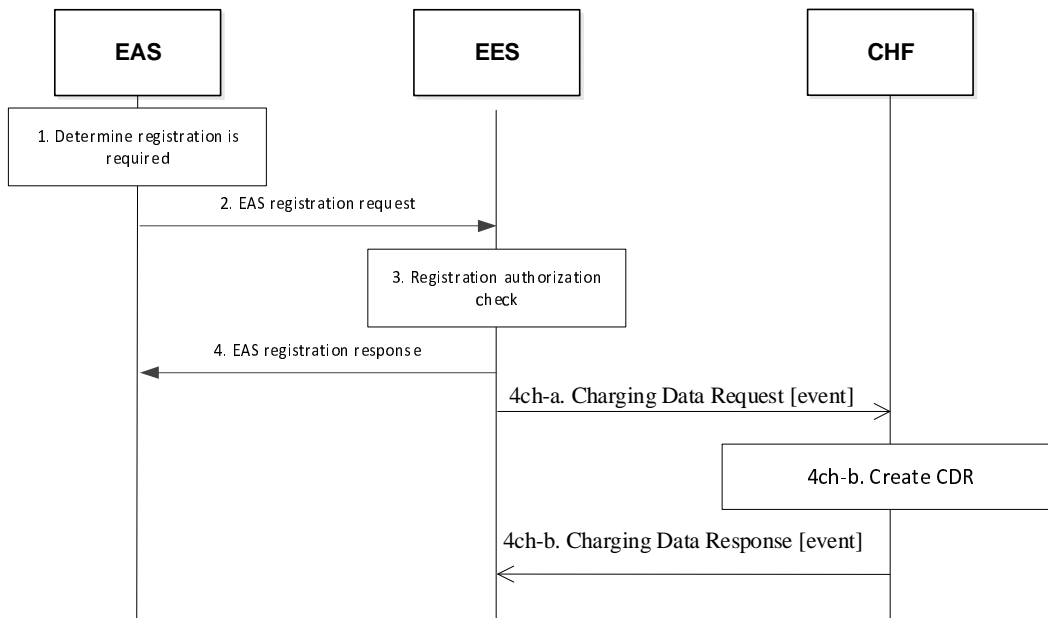

Figure 5.2.4.2.2.3-1: Charging for EAS registration - PEC

- 1) The EAS determines that registration to the EES is needed (e.g. the EAS is instantiated and started up).
- 2) The EAS sends an EAS registration request to the EES. The request shall include the EAS profile and may include proposed expiration time for the registration.
- 3) The EES performs an authorization check to verify whether the EAS has the authorization to register on the EES, if authorized.
- 4) Upon successful authorization, the EES stores the EAS Profile for later use (e.g. for serving EAS discovery requests received from EECs, etc.) and replies to the EAS with an EAS registration response:

4ch-a) Charging Data Request [Event]: The EES generates charging data related to the EAS Registration and sends the charging data request for the CHF to process the related charging data for CDR generation purpose.

4ch-b) Create CDR: The CHF stores received information and creates a CDR related to the event.

4ch-c) Charging Data Response [Event]: The CHF informs the EES on the result of the request.

5.2.4.2.3 EAS discovery charging

5.2.4.2.3.1 General

The clauses below describe the EAS discovery charging message flows.

For EAS discovery charging, the following scenarios specified in 3GPP TS 32.290 [6] are supported:

- IEC;
- PEC.

5.2.4.2.3.2 EAS discovery charging - IEC

Figure 5.2.4.2.3.2-1 describes an EAS discovery charging message flow in IEC charging.

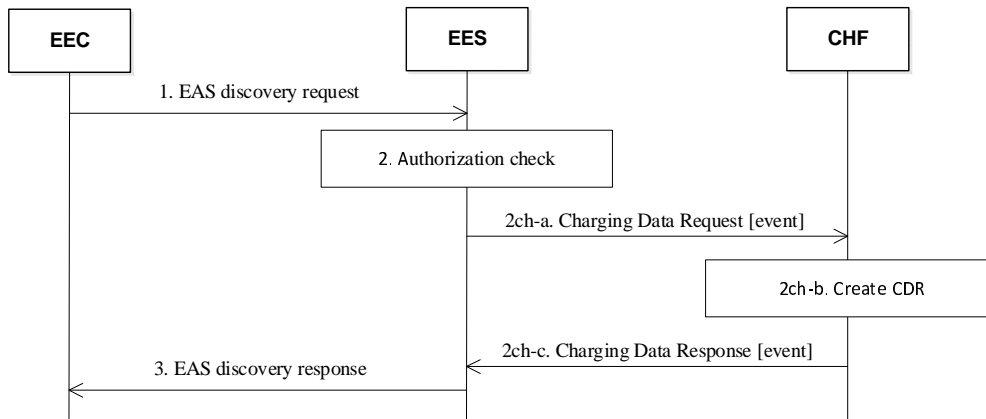

Figure 5.2.4.2.3.2-1: Charging for EAS discovery - IEC

- 1) The EEC sends the EES discovery request to the EES.
- 2) Upon receiving the request from the EEC, the EES checks if the EEC is authorized to discover the requested EAS(s). If authorized:
 - 2ch-a) Charging Data Request [Event]:** The EES generates charging data related to the EAS discovery request and sends the charging data request for the CHF to process the related charging data for CDR generation purpose.
 - 2ch-b) Create CDR:** The CHF stores received information and creates a CDR related to the event.
 - 2ch-c) Charging Data Response [Event]:** The CHF informs the EES on the result of the request.
- 3) The EES sends EAS discovery response to the EEC.

5.2.4.2.3.3 EAS discovery charging - PEC

Figure 5.2.4.2.3.3-1 describes an EAS discovery charging message flow in PEC charging.

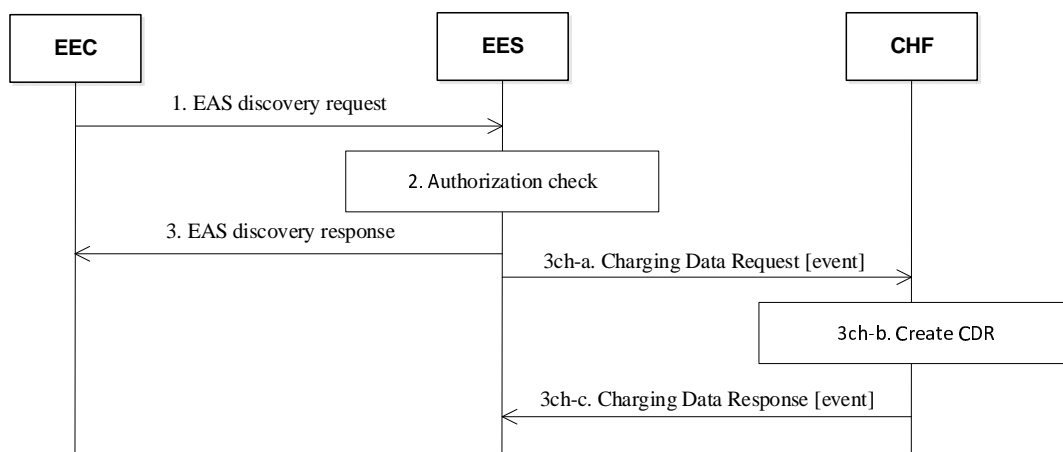

Figure 5.2.4.2.3.3-1: Charging for EAS discovery - PEC

- 1) The EEC sends the EAS discovery request to the EES.
- 2) Upon receiving the request from the EEC, the EES checks if the EEC is authorized to discover the requested EAS(s).

3) The EES sends EAS discovery response to the EEC:

- 3ch-a) Charging Data Request [Event]:** The EES generates charging data related to the EAS discovery and sends the charging data request for the CHF to process the related charging data for CDR generation purpose.
- 3ch-b) Create CDR:** The CHF stores received information and creates a CDR related to the event.
- 3ch-c) Charging Data Response [Event]:** The CHF informs the EES on the result of the request.

5.2.4.2.4 Support to Service Continuity charging

5.2.4.2.4.1 General

The clauses below describe the Support to Service Continuity charging message flows.

For Support to Service Continuity charging, the following scenarios specified in 3GPP TS 32.290 [6] are supported:

- IEC;
- PEC.

5.2.4.2.4.2 ACR charging - IEC

Figure 5.2.4.2.4.2-1 describes an ACR charging message flow in IEC charging.

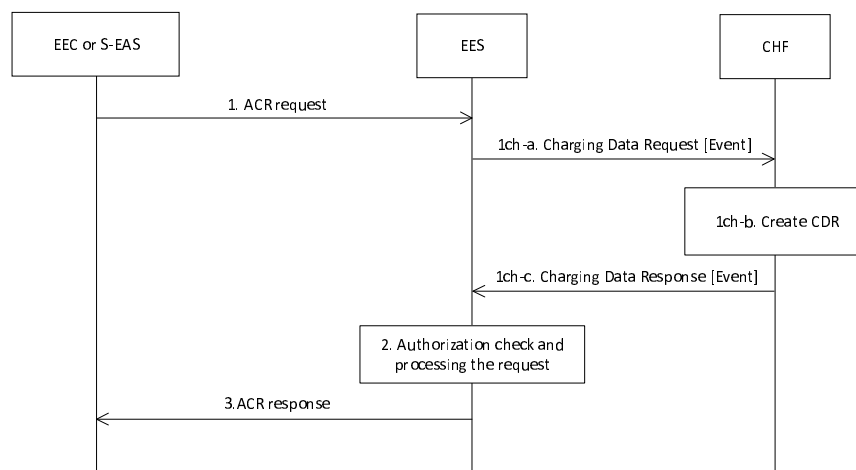

Figure 5.2.4.2.4.2-1: Charging for ACR - IEC

1) The EEC or S-EAS sends the ACR request to the EES:

- 1ch-a) Charging Data Request [Event]:** The EES generates charging data related to the ACR request and sends the charging data request for the CHF to process the related charging data for CDR generation purpose.
- 1ch-b) Create CDR:** The CHF stores received information and creates a CDR related to the event.
- 1ch-c) Charging Data Response [Event]:** The CHF informs the EES on the result of the request.

2) The EES checks the authorization and processes the request.

3) The EES sends ACR response to the EEC or S-EAS.

5.2.4.2.4.3 ACR charging - PEC

Figure 5.2.4.2.4.3-1 describes an ACR charging message flow in PEC charging.

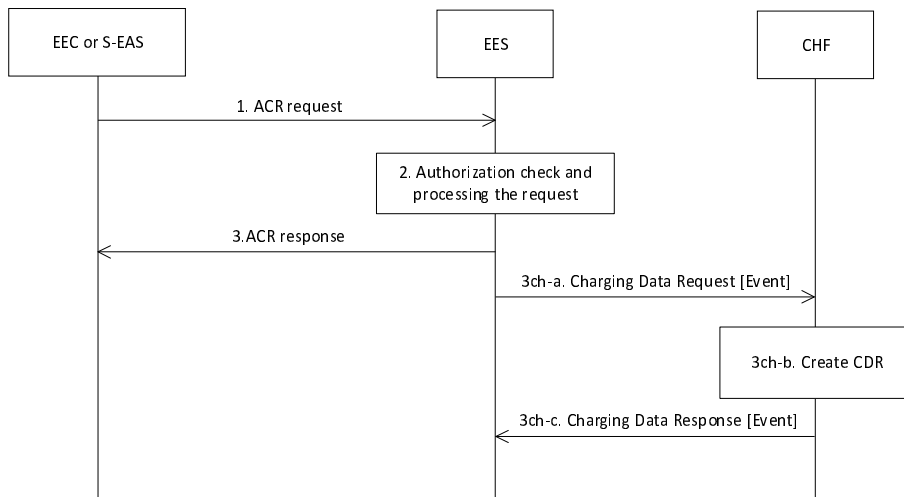

Figure 5.2.4.2.4.3-1: Charging for ACR - PEC

- 1) The EEC or S-EAS sends the ACR request to the EES.
- 2) The EES checks the authorization and processes the request.
- 3) The EES sends ACR response to the EEC or S-EAS.

1ch-a) Charging Data Request [Event]: The EES generates charging data related to the ACR and sends the charging data request for the CHF to process the related charging data for CDR generation purpose.

1ch-b) Create CDR: The CHF stores received information and creates a CDR related to the event.

1ch-c) Charging Data Response [Event]: The CHF informs the EES on the result of the request.

5.2.4.2.4.4 ACR status update charging - IEC

Figure 5.2.4.2.4.4-1 describes an ACR status update charging message flow in IEC charging.

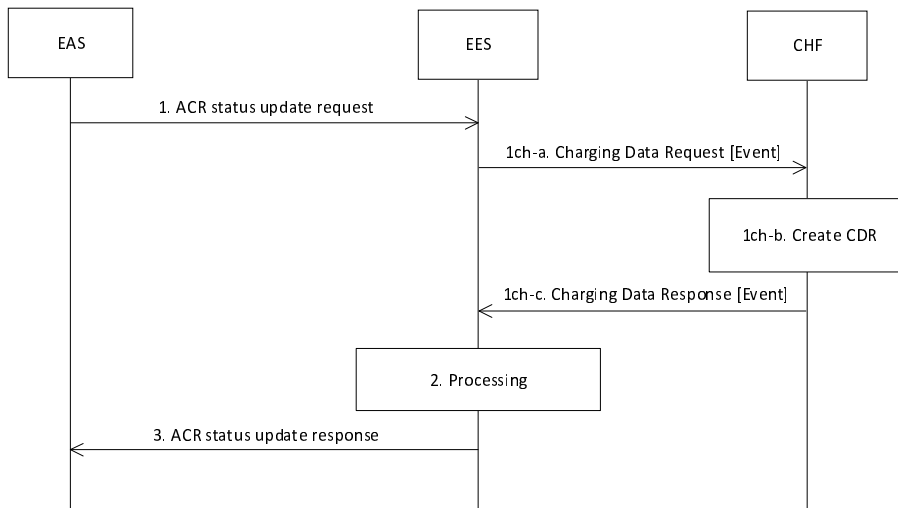

Figure 5.2.4.2.4.4-1: Charging for ACR status update - IEC

- 1) The EAS sends the ACR status update request to the EES:

1ch-a) Charging Data Request [Event]: The EES generates charging data related to the ACR status update request and sends the charging data request for the CHF to process the related charging data for CDR generation purpose.

1ch-b) Create CDR: The CHF stores received information and creates a CDR related to the event.

1ch-c) Charging Data Response [Event]: The CHF informs the EES on the result of the request.

- 2) The EES processes the request.
- 3) The EES sends ACR status update response to the EAS.

5.2.4.2.4.5 ACR status update charging - PEC

Figure 5.2.4.2.4.5-1 describes an ACR status update charging message flow in PEC charging.

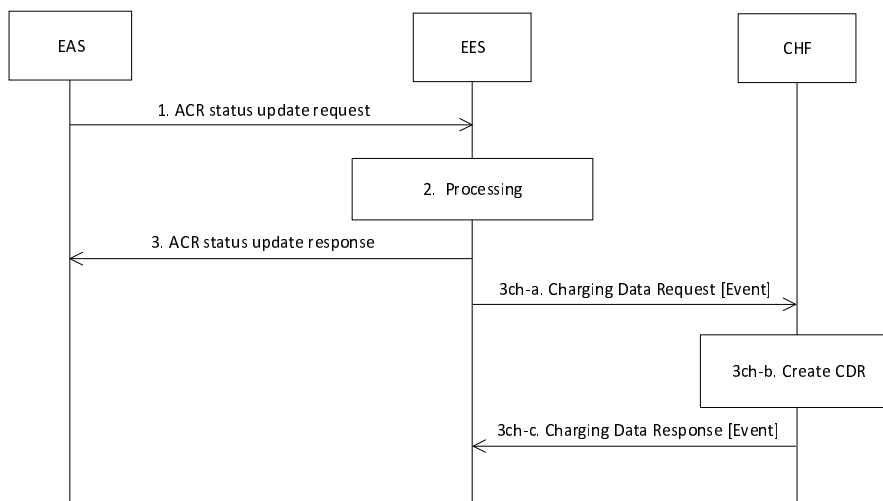

Figure 5.2.4.2.4.5-1: Charging for ACR status update - PEC

- 1) The EAS sends the ACR status update request to the EES.
- 2) The EES processes the request.
- 3) The EES sends ACR response to the EAS:

1ch-a) Charging Data Request [Event]: The EES generates charging data related to the ACR status update and sends the charging data request for the CHF to process the related charging data for CDR generation purpose.

1ch-b) Create CDR: The CHF stores received information and creates a CDR related to the event.

1ch-c) Charging Data Response [Event]: The CHF informs the EES on the result of the request.

5.2.4.2.5 Application Client information exposure charging

5.2.4.2.5.1 General

The clauses below describe the Application Client information exposure charging message flows.

For Application Client information exposure charging, the following scenarios specified in 3GPP TS 32.290 [6] are supported:

- IEC;
- PEC.

5.2.4.2.5.2 Application Client information subscription charging - IEC

Figure 5.2.4.2.5.2-1 describes an Application Client information subscription charging message flow in IEC charging.

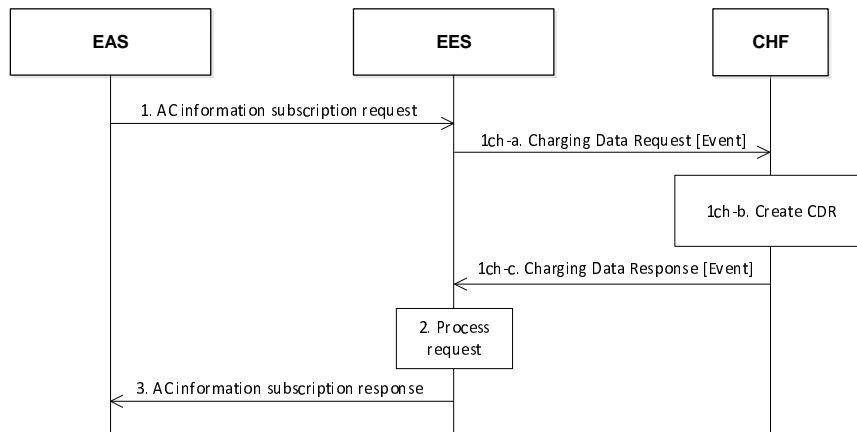

Figure 5.2.4.2.5.2-1: Charging for AC information subscription - IEC

1) The EAS sends the AC information subscription request to the EES:

1ch-a) Charging Data Request [Event]: The EES generates charging data related to AC information subscription request and sends the charging data request for the CHF to process the related charging data for CDR generation purpose.

1ch-b) Create CDR: The CHF stores received information and creates a CDR related to the event.

1ch-c) Charging Data Response [Event]: The CHF informs the EES on the result of the request.

2) The EES processes the request.

3) The EES sends the AC information subscription response to EAS.

5.2.4.2.5.3 Application Client information subscription charging - PEC

Figure 5.2.4.2.5.3-1 describes an Application Client information subscription charging message flow in PEC charging.

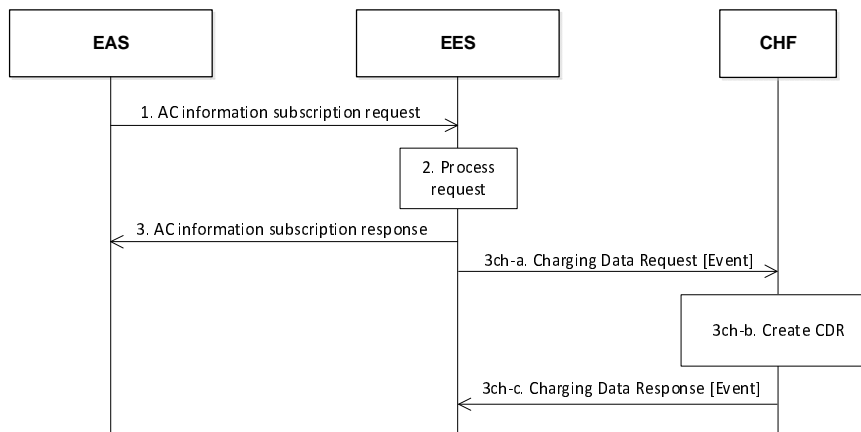

Figure 5.2.4.2.5.3-1: Charging for AC information subscription - PEC

1) The EAS sends the AC information subscription request to the EES.

2) The EES processes the request.

3) The EES sends the AC information subscription response to EAS:

3ch-a) Charging Data Request [Event]: The EES generates charging data related to AC information subscription and sends the charging data request for the CHF to process the related charging data for CDR generation purpose.

3ch-b) Create CDR: The CHF stores received information and creates a CDR related to the event.

3ch-c) Charging Data Response [Event]: The CHF informs the EES on the result of the request.

5.2.4.2.5.4 Application Client information subscription update charging - IEC

Figure 5.2.4.2.5.4-1 describes an Application Client information subscription update charging message flow in IEC charging.

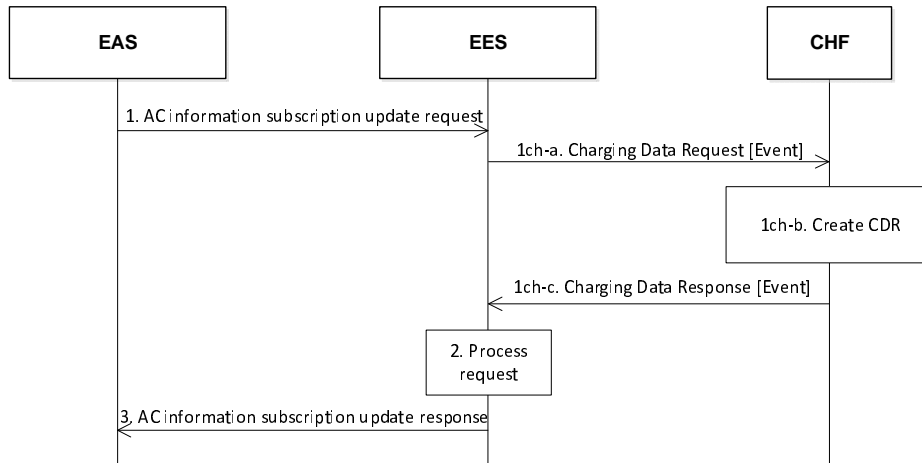

Figure 5.2.4.2.5.4-1: Charging for AC information subscription update - IEC

1) The EAS sends the AC information subscription update request to the EES:

1ch-a) Charging Data Request [Event]: The EES generates charging data related to AC information subscription update request and sends the charging data request for the CHF to process the related charging data for CDR generation purpose.

1ch-b) Create CDR: The CHF stores received information and creates a CDR related to the event.

1ch-c) Charging Data Response [Event]: The CHF informs the EES on the result of the request.

2) The EES processes the request.

3) The EES sends the AC information subscription update response to EAS.

5.2.4.2.5.5 Application Client information subscription update charging - PEC

Figure 5.2.4.2.5.5-1 describes an Application Client information subscription update charging message flow in PEC charging.

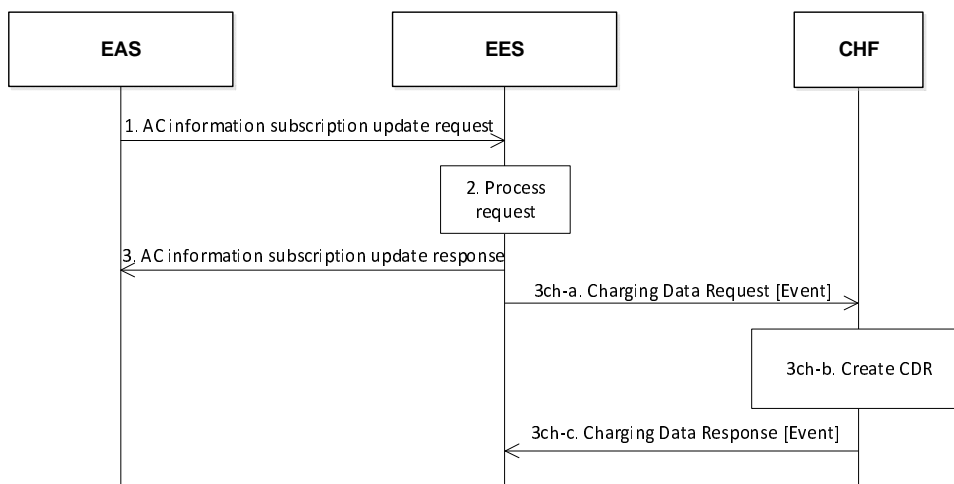

Figure 5.2.4.2.5.5-1: Charging for AC information subscription update - PEC

- 1) The EAS sends the AC information subscription update request to the EES.
- 2) The EES processes the request.
- 3) The EES sends the AC information subscription update response to EAS:

- 3ch-a) Charging Data Request [Event]:** The EES generates charging data related to AC information subscription update and sends the charging data request for the CHF to process the related charging data for CDR generation purpose.
- 3ch-b) Create CDR:** The CHF stores received information and creates a CDR related to the event.
- 3ch-c) Charging Data Response [Event]:** The CHF informs the EES on the result of the request.

5.2.4.2.5.6 Application Client information notification charging - PEC

Figure 5.2.4.2.5.6-1 describes an Application Client information notification charging message flow in PEC charging.

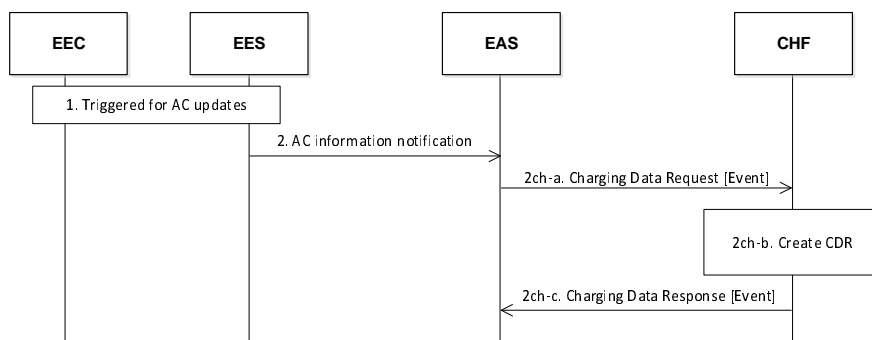

Figure 5.2.4.2.5.6-1: Charging for AC information notification - PEC

- 1) The EEC triggers for AC updates with EES.
- 2) The EES sends the AC information notification to the EAS:
 - 2ch-a) Charging Data Request [Event]:** The EES generates charging data related to AC information notification and sends the charging data request for the CHF to process the related charging data for CDR generation purpose.
 - 2ch-b) Create CDR:** The CHF stores received information and creates a CDR related to the event.
 - 2ch-c) Charging Data Response [Event]:** The CHF informs the EES on the result of the request.

5.2.4.2.6 UE location obtaining charging

5.2.4.2.6.1 General

The clauses below describe the UE location obtaining charging message flows.

For UE location obtaining charging, the following scenarios specified in 3GPP TS 32.290 [6] are supported:

- IEC;
- PEC.

5.2.4.2.6.2 UE location request charging - IEC

Figure 5.2.4.2.6.2-1 describes a UE location request charging message flow in IEC charging.

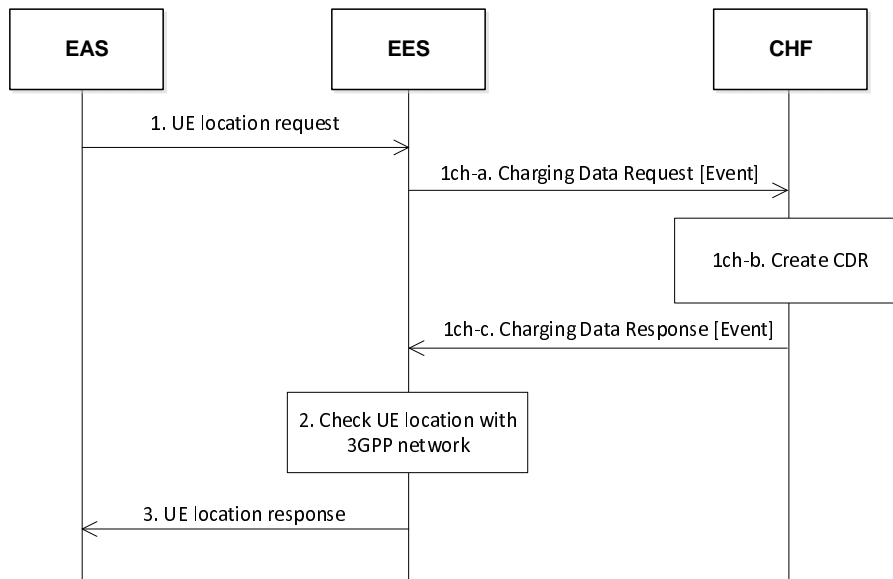

Figure 5.2.4.2.6.2-1: Charging for UE location request - IEC

1) The EAS sends the UE location request to the EES:

1ch-a) Charging Data Request [Event]: The EES generates charging data related to UE location request and sends the charging data request for the CHF to process the related charging data for CDR generation purpose.

1ch-b) Create CDR: The CHF stores received information and creates a CDR related to the event.

1ch-c) Charging Data Response [Event]: The CHF informs the EES on the result of the request.

2) The EES checks the UE location with 3GPP network.

3) The EES sends the UE location response to the EAS.

5.2.4.2.6.3 UE location request charging - PEC

Figure 5.2.4.2.6.3-1 describes a UE location request charging message flow in PEC charging.

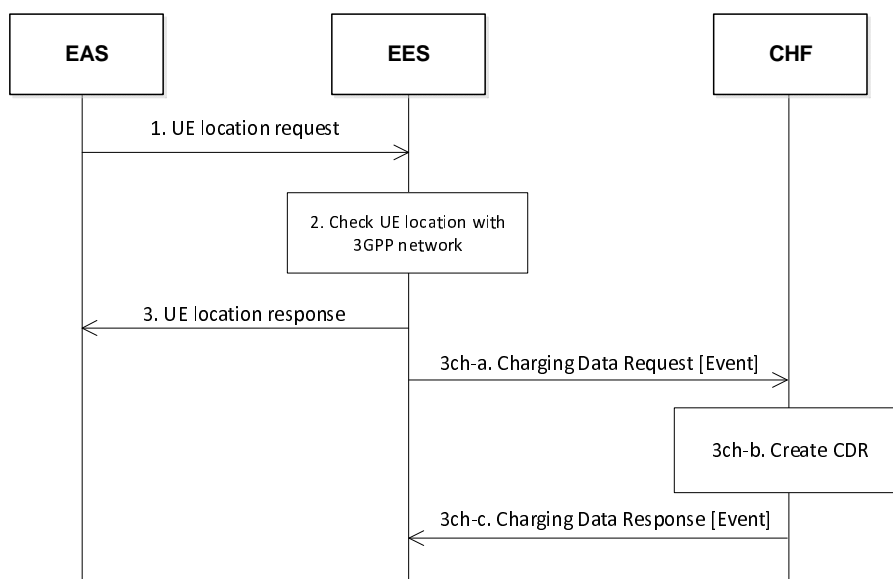

Figure 5.2.4.2.6.3-1: Charging for UE location request - PEC

1) The EAS sends the UE location request to the EES.

- 2) The EES checks the UE location with 3GPP network.
- 3) The EES sends the UE location response to the EAS:
 - 3ch-a) Charging Data Request [Event]:** The EES generates charging data related to UE location response and sends the charging data request for the CHF to process the related charging data for CDR generation purpose.
 - 3ch-b) Create CDR:** The CHF stores received information and creates a CDR related to the event.
 - 3ch-c) Charging Data Response [Event]:** The CHF informs the EES on the result of the request.

5.2.4.2.6.4 UE location subscription charging - IEC

Figure 5.2.4.2.6.4-1 describes a UE location subscription charging message flow in IEC charging.

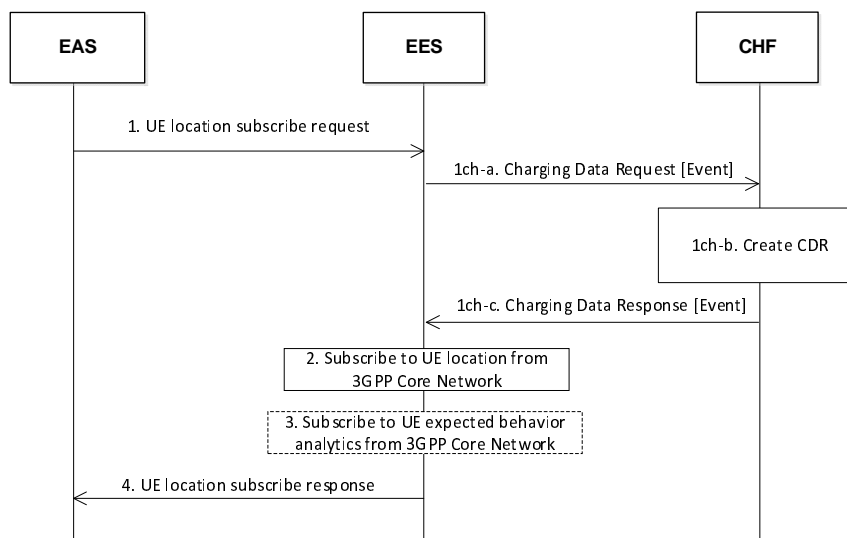

Figure 5.2.4.2.6.4-1: Charging for UE location subscription - IEC

- 1) The EAS sends the UE location subscribe request to the EES:
 - 1ch-a) Charging Data Request [Event]:** The EES generates charging data related to UE location subscribe request and sends the charging data request for the CHF to process the related charging data for CDR generation purpose.
 - 1ch-b) Create CDR:** The CHF stores received information and creates a CDR related to the event.
 - 1ch-c) Charging Data Response [Event]:** The CHF informs the EES on the result of the request.
- 2) The EES subscribes to UE location from 3GPP Core Network.
- 3) The EES may subscribe to UE expected behaviour analytics (UE mobility) from 3GPP Core Network.
- 4) The EES sends the UE location subscribe response to the EAS.

5.2.4.2.6.5 UE location subscription charging - PEC

Figure 5.2.4.2.6.5-1 describes a UE location subscription charging message flow in PEC charging.

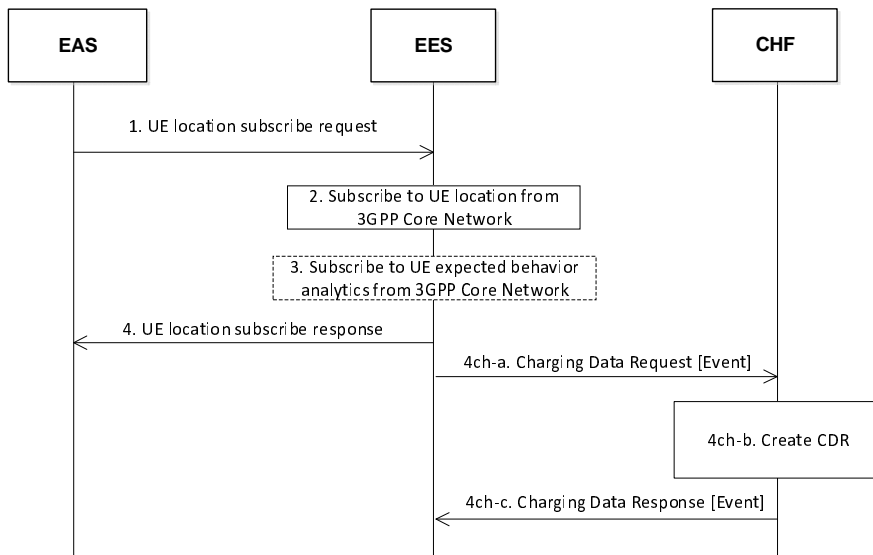

Figure 5.2.4.2.6.5-1: Charging for UE location subscription - PEC

- 1) The EAS sends the UE location subscribe request to the EES.
- 2) The EES subscribes to UE location from 3GPP Core Network.
- 3) The EES may subscribe to UE expected behaviour analytics (UE mobility) from 3GPP Core Network (see 3GPP TS 23.558 [9]).
- 4) The EES sends the UE location subscribe response to the EAS:

4ch-a) Charging Data Request [Event]: The EES generates charging data related to UE location subscribing and sends the charging data request for the CHF to process the related charging data for CDR generation purpose.

4ch-b) Create CDR: The CHF stores received information and creates a CDR related to the event.

4ch-c) Charging Data Response [Event]: The CHF informs the EES on the result of the request.

5.2.4.2.6.6 UE location subscription update charging - IEC

Figure 5.2.4.2.6.6-1 describes a UE location subscription update charging message flow in IEC charging.

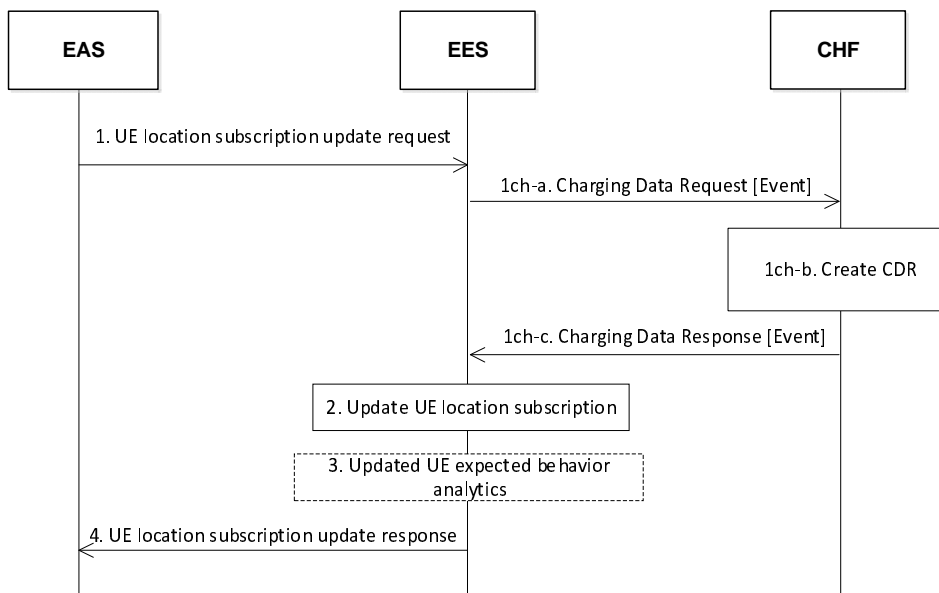

Figure 5.2.4.2.6.6-1: Charging for UE location subscription - IEC

- 1) The EAS sends the UE location subscription update request to the EES:
 - 1ch-a) Charging Data Request [Event]:** The EES generates charging data related to UE location subscription update request and sends the charging data request for the CHF to process the related charging data for CDR generation purpose.
 - 1ch-b) Create CDR:** The CHF stores received information and creates a CDR related to the event.
 - 1ch-c) Charging Data Response [Event]:** The CHF informs the EES on the result of the request.
- 2) The EES updates the UE location subscription to 3GPP Core Network.
- 3) The EES may subscribe to updated UE expected behaviour analytics (UE mobility) from 3GPP Core Network (see 3GPP TS 23.558 [9]).
- 4) The EES sends the UE location subscription update response to the EAS.

5.2.4.2.6.7 UE location subscription update charging - PEC

Figure 5.2.4.2.6.7-1 describes a UE location subscription update charging message flow in PEC charging.

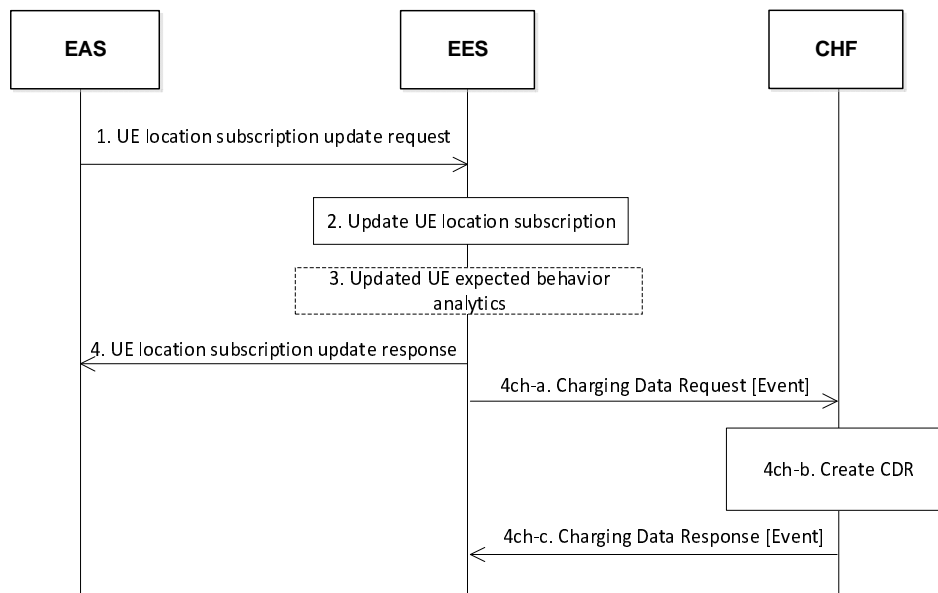

Figure 5.2.4.2.6.7-1: Charging for UE location subscription - PEC

- 1) The EAS sends the UE location subscription update request to the EES.
- 2) The EES updates the UE location subscription to 3GPP Core Network.
- 3) The EES may subscribe to updated UE expected behaviour analytics (UE mobility) from 3GPP Core Network (see 3GPP TS 23.558 [9]).
- 4) The EES sends the UE location subscription update response to the EAS:
 - 4ch-a) Charging Data Request [Event]:** The EES generates charging data related to UE location subscription update and sends the charging data request for the CHF to process the related charging data for CDR generation purpose.
 - 4ch-b) Create CDR:** The CHF stores received information and creates a CDR related to the event.
 - 4ch-c) Charging Data Response [Event]:** The CHF informs the EES on the result of the request.

5.2.4.2.6.8 UE location notification charging - PEC

Figure 5.2.4.2.6.8-1 describes a UE location notification charging message flow in PEC charging.

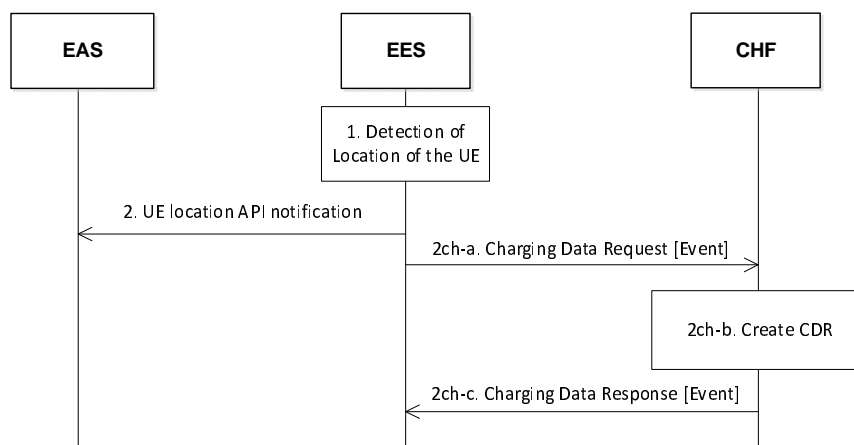

Figure 5.2.4.2.6.8-1: Charging for UE location notification - PEC

1) The EES detects the UE location.

2) The EES sends the UE location notification to the EAS:

2ch-a) Charging Data Request [Event]: The EES generates charging data related to UE location notification and sends the charging data request for the CHF to process the related charging data for CDR generation purpose.

2ch-b) Create CDR: The CHF stores received information and creates a CDR related to the event.

2ch-c) Charging Data Response [Event]: The CHF informs the EES on the result of the request.

5.2.4.2.7 ACR management events subscription charging

5.2.4.2.7.1 General

The clauses below describe the ACR management events subscription charging message flows.

For ACR management events subscription charging, the following scenarios specified in 3GPP TS 32.290 [6] are supported:

- IEC;
- PEC.

5.2.4.2.7.2 ACR management events subscription charging - IEC

Figure 5.2.4.2.7.2-1 describes an ACR management events subscription charging message flow in IEC charging.

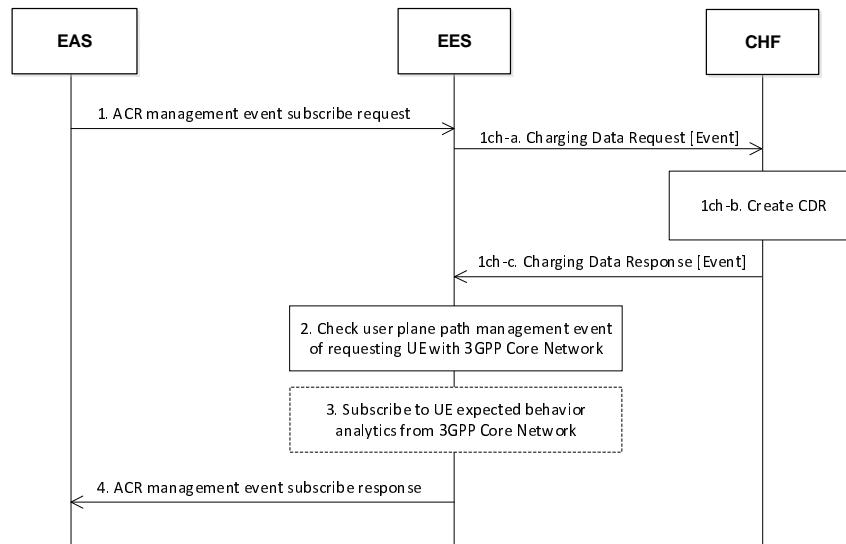

Figure 5.2.4.2.7.2-1: Charging for ACR management event subscription - IEC

- 1) The EAS sends the ACR management event subscribe request to the EES:
 - 1ch-a) Charging Data Request [Event]:** The EES generates charging data related to ACR management event subscribe request and sends the charging data request for the CHF to process the related charging data for CDR generation purpose.
 - 1ch-b) Create CDR:** The CHF stores received information and creates a CDR related to the event.
 - 1ch-c) Charging Data Response [Event]:** The CHF informs the EES on the result of the request.
- 2) The EES checks the user plane path management event of the requesting UE with 3GPP Core Network.
- 3) The EES may subscribe to UE expected behaviour analytics (UE mobility) from 3GPP Core Network.
- 4) The EES sends the ACR management event subscribe response to the EAS.

5.2.4.2.7.3 ACR management events subscription charging - PEC

Figure 5.2.4.2.7.3-1 describes an ACR management events subscription charging message flow in PEC charging.

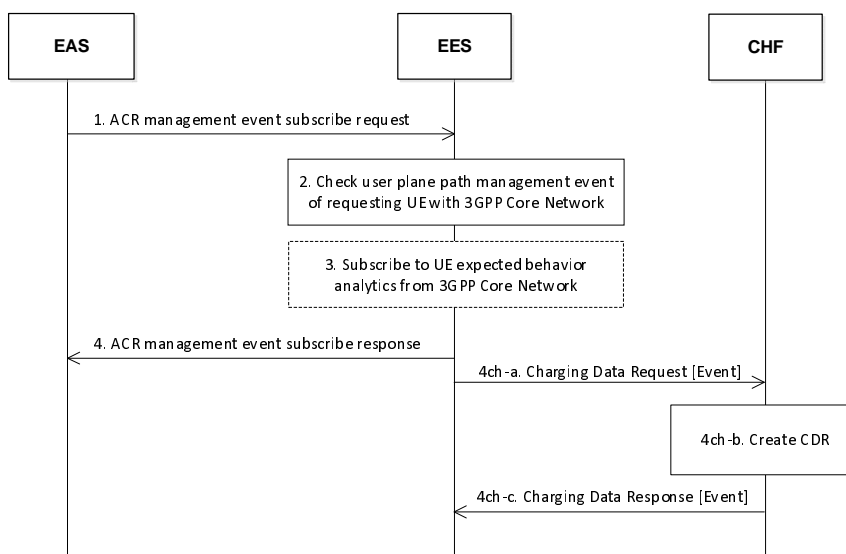

Figure 5.2.4.2.7.3-1: Charging for ACR management event subscription - PEC

- 1) The EAS sends the ACR management event subscribe request to the EES.

- 2) The EES checks the user plane path management event of the requesting UE with 3GPP Core Network.
- 3) The EES may subscribe to UE expected behaviour analytics (UE mobility) from 3GPP Core Network.
- 4) The EES sends the ACR management event subscribe response to the EAS:

- 4ch-a) Charging Data Request [Event]:** The EES generates charging data related to ACR management event subscribing and sends the charging data request for the CHF to process the related charging data for CDR generation purpose.
- 4ch-b) Create CDR:** The CHF stores received information and creates a CDR related to the event.
- 4ch-c) Charging Data Response [Event]:** The CHF informs the EES on the result of the request.

5.2.4.2.7.4 ACR management events subscription update charging - IEC

Figure 5.2.4.2.7.4-1 describes an ACR management events subscription update charging message flow in IEC charging.

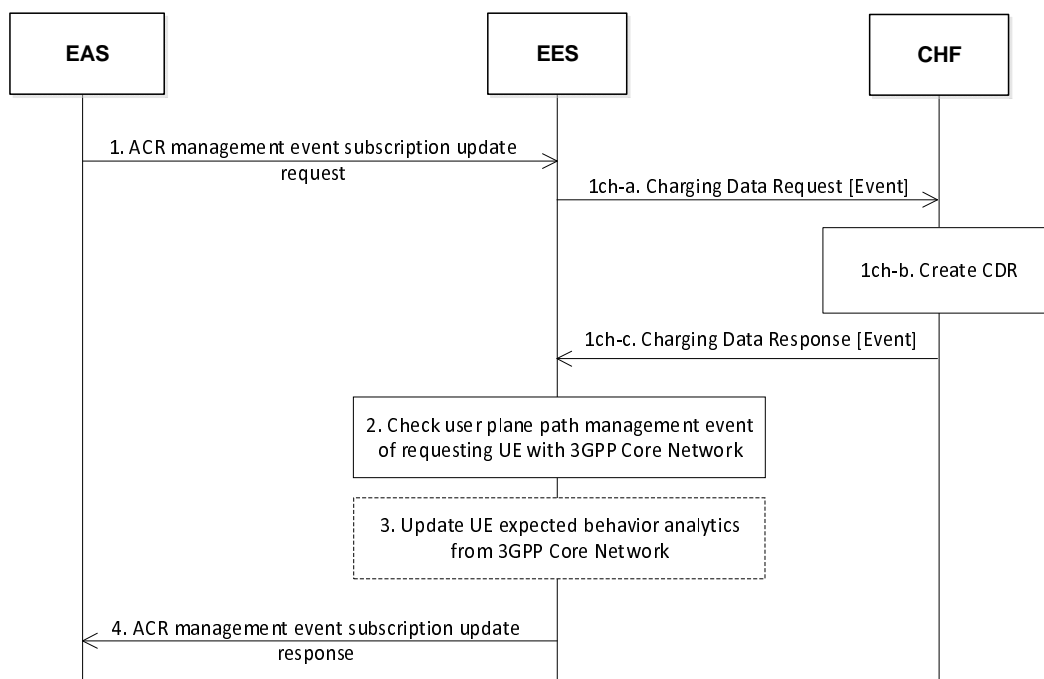

Figure 5.2.4.2.7.4-1: Charging for ACR management event subscription update - IEC

- 1) The EAS sends the ACR management event subscription update request to the EES:
 - 1ch-a) Charging Data Request [Event]:** The EES generates charging data related to ACR management event subscription update request and sends the charging data request for the CHF to process the related charging data for CDR generation purpose.
 - 1ch-b) Create CDR:** The CHF stores received information and creates a CDR related to the event.
 - 1ch-c) Charging Data Response [Event]:** The CHF informs the EES on the result of the request.
- 2) The EES checks the user plane path management event of the requesting UE with 3GPP Core Network.
- 3) The EES updates UE expected behaviour analytics (UE mobility) to 3GPP Core Network.
- 4) The EES sends the ACR management event subscription update response (see 3GPP TS 23.558 [9]) to the EAS.

5.2.4.2.7.5 ACR management events subscription update charging - IEC

Figure 5.2.4.2.7.5-1 describes an ACR management events subscription update charging message flow in IEC charging.

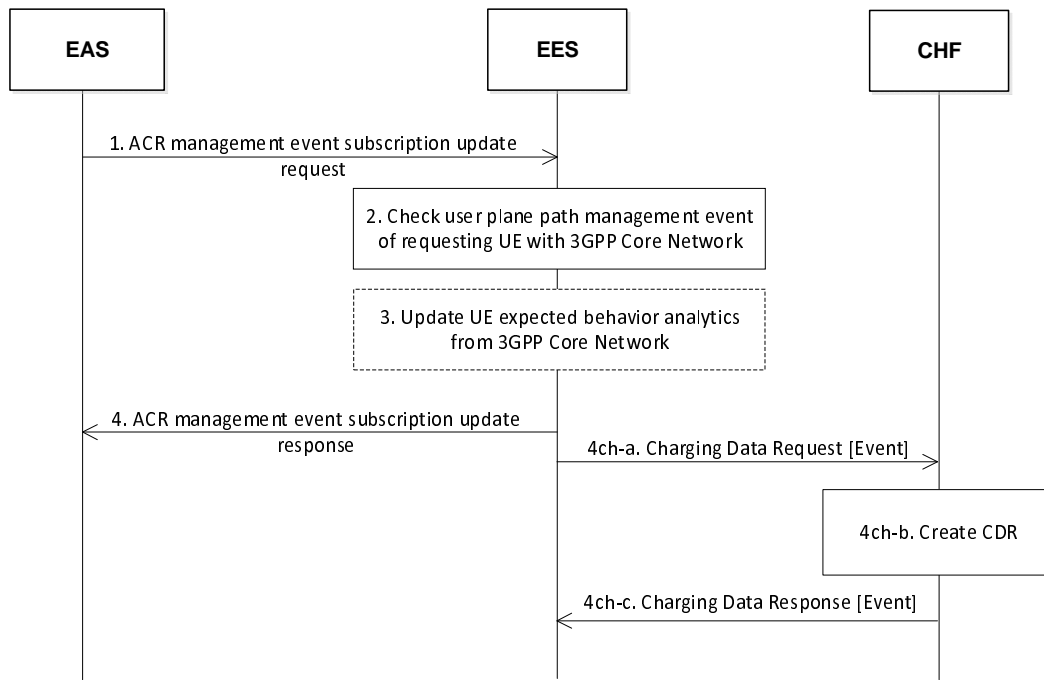

Figure 5.2.4.2.7.5-1: Charging for ACR management event subscription update - PEC

- 1) The EAS sends the ACR management event subscription update request to the EES.
- 2) The EES checks the user plane path management event of the requesting UE with 3GPP Core Network.
- 3) The EES updates UE expected behaviour analytics (UE mobility) to 3GPP Core Network.
- 4) The EES sends the ACR management event subscription update response to the EAS:
 - 4ch-a) Charging Data Request [Event]:** The EES generates charging data related to ACR management event subscription update and sends the charging data request for the CHF to process the related charging data for CDR generation purpose.
 - 4ch-b) Create CDR:** The CHF stores received information and creates a CDR related to the event.
 - 4ch-c) Charging Data Response [Event]:** The CHF informs the EES on the result of the request.

5.2.4.2.8 Session with QoS charging

5.2.4.2.8.1 General

The clauses below describe the Session with QoS charging message flows.

For Session with QoS charging, the following scenarios specified in 3GPP TS 32.290 [6] are supported:

- IEC;
- PEC.

5.2.4.2.8.2 Session with QoS creation charging - IEC

Figure 5.2.4.2.8.2-1 describes a Session with QoS creation charging message flow in IEC charging.

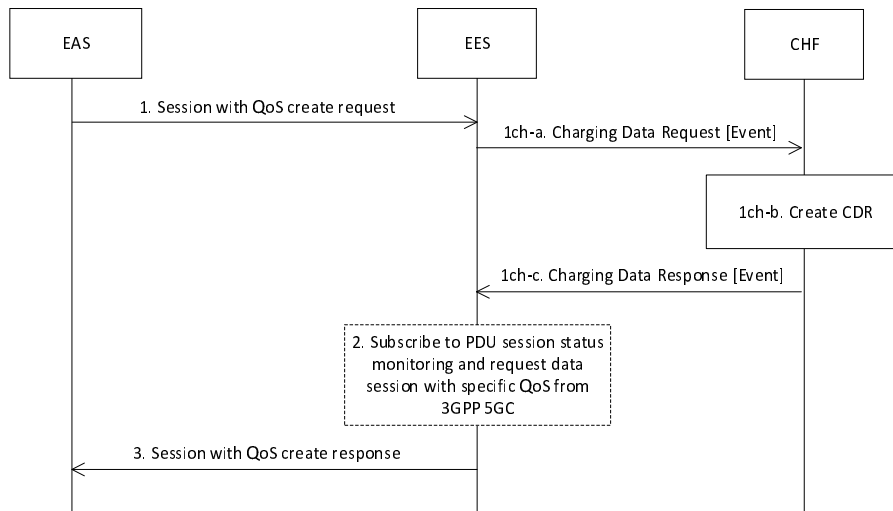

Figure 5.2.4.2.8.2-1: Charging for creation of Session with QoS - IEC

1) The EAS sends the Session with QoS create request to the EES:

1ch-a) Charging Data Request [Event]: The EES generates charging data related to Session with QoS create request and sends the charging data request for the CHF to process the related charging data for CDR generation purpose.

1ch-b) Create CDR: The CHF stores received information and creates a CDR related to the event.

1ch-c) Charging Data Response [Event]: The CHF informs the EES on the result of the request.

2) The EES subscribes to PDU session status monitoring and request data session with specific QoS from 3GPP 5G Core Network.

3) The EES sends Session with QoS create response to the EAS.

5.2.4.2.8.3 Session with QoS creation charging - PEC

Figure 5.2.4.2.8.3-1 describes a Session with QoS creation charging message flow in PEC charging.

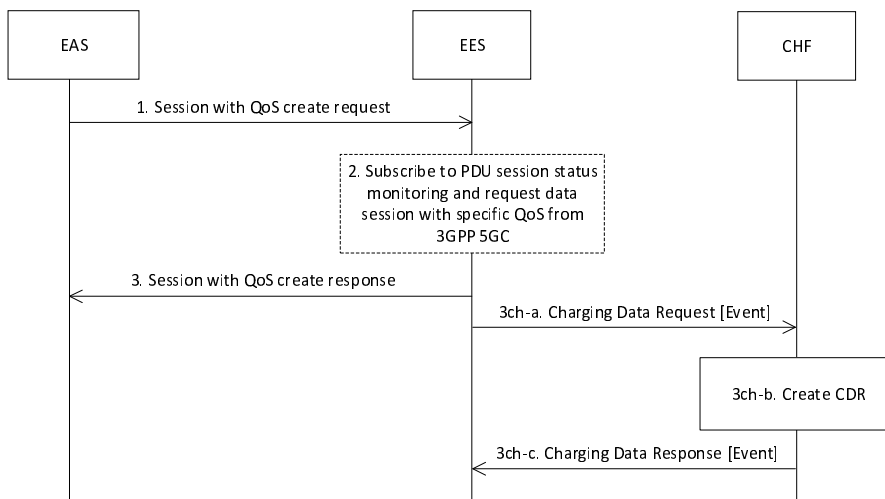

Figure 5.2.4.2.8.3-1: Charging for creation of Session with QoS - PEC

1) The EAS sends the Session with QoS create request to the EES.

2) The EES subscribes to PDU session status monitoring and request data session with specific QoS from 3GPP 5G Core Network.

3) The EES sends Session with QoS create response to the EAS:

- 3ch-a) Charging Data Request [Event]:** The EES generates charging data related to Session with QoS creation and sends the charging data request for the CHF to process the related charging data for CDR generation purpose.
- 3ch-b) Create CDR:** The CHF stores received information and creates a CDR related to the event.
- 3ch-c) Charging Data Response [Event]:** The CHF informs the EES on the result of the request.

5.2.4.2.8.4 Session with QoS update charging - IEC

Figure 5.2.4.2.8.4-1 describes a Session with QoS update charging message flow in IEC charging.

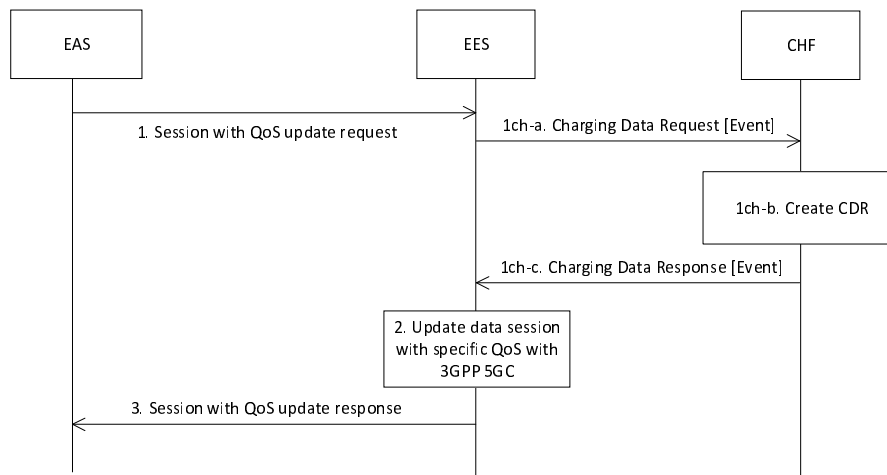

Figure 5.2.4.2.8.4-1: Charging for update of Session with QoS - IEC

1) The EAS sends the Session with QoS update request to the EES:

- 1ch-a) Charging Data Request [Event]:** The EES generates charging data related to Session with QoS update request and sends the charging data request for the CHF to process the related charging data for CDR generation purpose.
- 1ch-b) Create CDR:** The CHF stores received information and creates a CDR related to the event.
- 1ch-c) Charging Data Response [Event]:** The CHF informs the EES on the result of the request.

2) The EES updates data session with specific QoS with 3GPP 5G Core Network.

3) The EES sends Session with QoS update response to the EAS.

5.2.4.2.8.5 Session with QoS update charging - PEC

Figure 5.2.4.2.8.5-1 describes a Session with QoS update charging message flow in PEC charging.

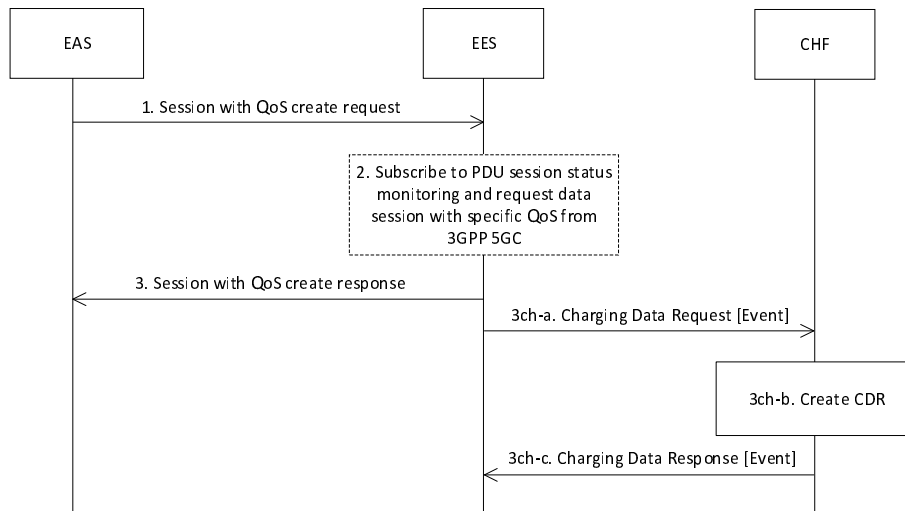

Figure 5.2.4.2.8.5-1: Charging for update of Session with QoS - PEC

- 1) The EAS sends the Session with QoS update request to the EES.
- 2) The EES updates data session with specific QoS with 3GPP 5G Core Network.
- 3) The EES sends Session with QoS update response to the EAS:
 - 3ch-a) Charging Data Request [Event]:** The EES generates charging data related to Session with QoS update and sends the charging data request for the CHF to process the related charging data for CDR generation purpose.
 - 3ch-b) Create CDR:** The CHF stores received information and creates a CDR related to the event.
 - 3ch-c) Charging Data Response [Event]:** The CHF informs the EES on the result of the request.

5.2.4.2.8.6 Session with QoS notification charging - PEC

Figure 5.2.4.2.8.6-1 describes a Session with QoS notification charging message flow in PEC charging.

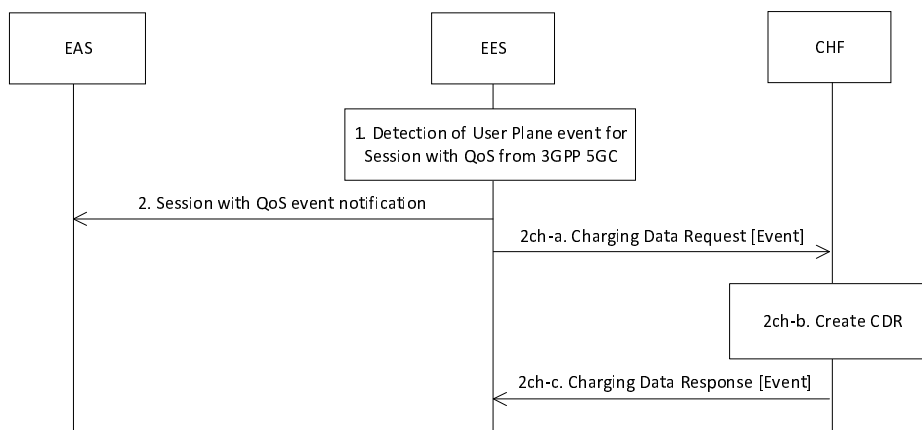

Figure 5.2.4.2.8.6-1: Charging for Session with QoS notification - PEC

- 1) The EES detects User Plane event for Session with QoS from 3GPP 5G Core Network.
- 2) The EES sends Session with QoS notification to EAS:
 - 2ch-a) Charging Data Request [Event]:** The EES generates charging data related to Session with QoS notification and sends the charging data request for the CHF to process the related charging data for CDR generation purpose.
 - 2ch-b) Create CDR:** The CHF stores received information and creates a CDR related to the event.

2ch-c) Charging Data Response [Event]: The CHF informs the EES on the result of the request.

5.2.4.3 CDR generation

5.2.4.3.1 Introduction

The CHF CDRs for edge enabling services charging are generated by the CHF to collect charging information that they subsequently transfer to the Charging Gateway Function (CGF).

The following clauses describe in detail the conditions for generating the CHF CDR.

5.2.4.3.2 Triggers for CHF CDR

5.2.4.3.2.1 General

An edge enabling services charging CHF CDR is used to collect charging information related to edge enabling services chargeable events for IEC and PEC.

5.2.4.3.2.2 Triggers for CHF CDR generation

A CHF CDR shall be generated by the CHF for each received Charging Data Request [Event].

5.2.4.4 Ga record transfer flows

For Ga protocol application refer to 3GPP TS 32.295 [5].

5.2.4.5 Bee CDR file transfer

For Bee protocol application refer to 3GPP TS 32.297 [4].

6 Definition of Edge Computing charging information

6.1 Definition of charging information for edge enabling infrastructure resource usage charging

6.1.1 Data description for edge enabling infrastructure resource usage charging

6.1.1.1 Message contents

6.1.1.1.1 General

The Charging Data Request and Charging Data Response are specified in 3GPP TS 32.290 [6] and include charging information. The Charging Data Request can be of type [Event].

Table 6.1.1.1.1-1 describes the use of these messages for converged charging.

Table 6.1.1.1.1-1: Converged charging messages reference table

Message	Source	Destination
Charging Data Request	CEF	CHF
Charging Data Response	CHF	CEF

The following clauses describe the different fields used in the Charging Data messages and the category in the tables is used according to the charging data configuration defined in clause 5.4 of 3GPP TS 32.240 [2].

6.1.1.1.2 Charging Data Request message

Table 6.1.1.1.2-1 illustrates the basic structure of a Charging Data Request message from the CEF as used for edge enabling infrastructure resource usage converged charging.

Table 6.1.1.1.2-1: Charging Data Request message contents

Information Element	Converged Charging Category	Description
Session Identifier	-	This field is not applicable.
Subscriber Identifier	-	This field is not applicable.
NF Consumer Identification	M	Described in 3GPP TS 32.290 [6].
NF Functionality	M	Described in 3GPP TS 32.290 [6].
NF Name	O _C	Described in 3GPP TS 32.290 [6].
NF Address	O _C	Described in 3GPP TS 32.290 [6].
NF PLMN ID	O _C	Described in 3GPP TS 32.290 [6].
Charging Identifier	O _M	Described in 3GPP TS 32.290 [6].
Invocation Timestamp	M	Described in 3GPP TS 32.290 [6].
Invocation Sequence Number	-	This field is not applicable.
Retransmission Indicator	O _C	Described in 3GPP TS 32.290 [6].
One-time Event	O _C	Described in 3GPP TS 32.290 [6].
One-time Event Type	O _C	Described in 3GPP TS 32.290 [6].
Notify URI	-	This field is not applicable.
Supported Features	O _C	Described in 3GPP TS 32.290 [6].
Service Specification Information	O _C	Described in 3GPP TS 32.290 [6].
Triggers	O _C	Described in 3GPP TS 32.290 [6].
Multiple Unit Usage	O _M	Described in 3GPP TS 32.290 [6].
Rating Group	O _M	Described in 3GPP TS 32.290 [6].
Requested Unit	-	This field is not applicable.
Used Unit Container	O _M	Described in 3GPP TS 32.290 [6].
Service Identifier	O _M	Described in 3GPP TS 32.290 [6].
Quota management Indicator	-	This field is not applicable.
Triggers	O _M	Described in 3GPP TS 32.290 [6].
Trigger Timestamp	O _M	Described in 3GPP TS 32.290 [6].
Time	O _M	Described in 3GPP TS 32.290 [6].
Total Volume	-	Described in 3GPP TS 32.290 [6].
Uplink Volume	O _M	This field holds the information of incoming data volume for the EAS, see DataVolum.InBytesEAS in clause 5.7.2.1 of 3GPP TS 28.552 [13].
Downlink Volume	O _M	This field holds the information of outgoing data volume for the EAS, see DataVolum.OutBytesEAS in clause 5.7.2.2 of 3GPP TS 28.552 [13].
Service Specific Unit	-	This field is not applicable.
Event Time Stamps	-	This field is not applicable.
Local Sequence Number	-	This field is not applicable.
EAS ID	O _M	This field holds the EAS ID, see 3GPP TS 23.558 [9].
EDN ID	O _M	This field holds the DN of EdgeDataNetwork MOI, see 3GPP TS 28.538 [12].
EAS Provider Identifier	O _M	The identifier of the ASP that provides the EAS, see 3GPP TS 23.558 [9].
Edge Enabling Infrastructure Resource Usage Charging Information	O _M	This field holds the for edge enabling infrastructure resource usage charging specific information described in clause 6.1.2.1.2.

6.1.1.1.3 Charging data response message

Table 6.1.1.1.3-1 illustrates the basic structure of a Charging Data Response message from the CHF as used for edge enabling infrastructure resource usage converged charging.

Table 6.1.1.1.3-1: Charging Data Response message contents

Information Element	Converged Charging Category	Description
Session Identifier	-	Described in 3GPP TS 32.290 [6].
Invocation Timestamp	M	Described in 3GPP TS 32.290 [6].
Invocation Result	O _c	Described in 3GPP TS 32.290 [6].
Invocation Result Code	O _c	Described in 3GPP TS 32.290 [6].
Failed parameter	O _c	Described in 3GPP TS 32.290 [6].
Failure Handling	O _c	Described in 3GPP TS 32.290 [6].
Invocation Sequence Number	-	This field is not applicable.
Session Failover	-	This field is not applicable.
Supported Features	O _c	Described in 3GPP TS 32.290 [6].
Triggers	-	This field is not applicable.
Multiple Unit Information	O _c	Described in 3GPP TS 32.290 [6].
Result Code	O _c	Described in 3GPP TS 32.290 [6].
Rating Group	-	This field is not applicable.
Granted Unit	-	This field is not applicable.
Validity Time	-	This field is not applicable.
Final Unit Indication	-	This field is not applicable.
Time Quota Threshold	-	This field is not applicable.
Volume Quota Threshold	-	This field is not applicable.
Unit Quota Threshold	-	This field is not applicable.
Quota Holding Time	-	This field is not applicable.
Triggers	-	This field is not applicable.

6.1.1.2 Ga message contents

See clause 5.2.2.4.

6.1.1.3 CDR description on the Bee interface

6.1.1.3.1 General

This clause describes the CDR content and format generated for edge enabling infrastructure resource usage charging.

The following tables provide a brief description of each CDR parameter. The category in the tables is used according to the charging data configuration defined in clause 5.4 of 3GPP TS 32.240 [2]. Full definitions of the CDR parameters, sorted by the name in alphabetical order, are provided in 3GPP TS 32.298 [3].

6.1.1.3.2 Edge enabling infrastructure resource usage charging CHF CDR data

If enabled, CHF CDRs for edge enabling infrastructure resource usage charging shall be produced for each performance measurement report.

The fields of enabling infrastructure resource usage charging CHF CDR are specified in table 6.1.1.3.2-1.

Table 6.1.1.3.2-1: Edge enabling infrastructure resource usage charging CHF record data

Field	Category	Description
Record Type	M	Described in 3GPP TS 32.298 [3]
Recording Network Function ID	O _M	Described in 3GPP TS 32.298 [3]
Tenant Identifier	O _M	Described in 3GPP TS 32.298 [3]
MnS Consumer Identifier	O _C	Described in 3GPP TS 32.298 [3]
NF Consumer Information	M	This field holds the information of the CEF that used the charging service
NF Functionality	M	This field contains the function of the node (i.e. CEF)
NF Name	O _C	This field holds the name of the CEF used
NF Address	O _C	This fields holds the IP Address of the CEF used
NF PLMN ID	O _C	This field holds the PLMN identifier (MCC MNC) of the CEF
Charging Identifier	O _M	Described in 3GPP TS 32.298 [3]
Triggers	O _M	Described in 3GPP TS 32.298 [3]
List of Multiple Unit Usage	O _M	This field holds a list of changes in charging conditions for the edge enabling infrastructure resource usage
Rating Group	O _M	Described in 3GPP TS 32.298 [3]
Used Unit Container	O _M	Described in 3GPP TS 32.298 [3]
Time	O _M	This field holds the amount of used time
Uplink Volume	O _M	This field holds the information of incoming data volume for the EAS, see DataVolum.InBytesEAS in clause 5.7.2.1 of 3GPP TS 28.552 [13]
Downlink Volume	O _M	This field holds the information of outgoing data volume for the EAS, see DataVolum.OutBytesEAS in clause 5.7.2.2 of 3GPP TS 28.552 [13]
Duration	M	Described in 3GPP TS 32.298 [3]
Record Sequence Number	C	Described in 3GPP TS 32.298 [3]
Cause for Record Closing	M	Described in 3GPP TS 32.298 [3]
Local Record Sequence Number	O _M	Described in 3GPP TS 32.298 [3]
Record Extensions	O _C	Described in 3GPP TS 32.298 [3]
Service Specification Information	O _C	Described in 3GPP TS 32.298 [3]
EAS ID	O _M	This field holds the EAS ID, see 3GPP TS 23.558 [9]
EDN ID	O _M	This field holds the DN of EdgeDataNetwork MOI, see 3GPP TS 28.538 [12]
EAS Provider Identifier	O _M	The identifier of the ASP that provides the EAS, see 3GPP TS 23.558 [9]
Edge Enabling Infrastructure Resource Usage Charging Information	O _M	This field holds the for edge enabling infrastructure resource usage charging specific information described in clause 6.1.2.1.2

6.1.2 Edge enabling infrastructure resource usage charging specific parameters

6.1.2.1 Definition of edge enabling infrastructure resource usage charging information

6.1.2.1.1 General

The Charging Information parameter used for edge enabling infrastructure resource usage charging is provided in the following clauses.

6.1.2.1.2 Definition of edge enabling infrastructure resource usage specific charging information

Specific charging information used for edge enabling infrastructure resource usage charging is provided within the Edge Enabling Infrastructure Resource Usage Charging Information.

The detailed structure of the Edge Enabling Infrastructure Resource Usage Charging Information can be found in table 6.1.2.1.2-1.

Table 6.1.2.1.2-1: Structure of Edge Enabling Infrastructure Resource Usage Charging Information

Information Element	Category	Description
Mean Virtual CPU Usage	O _M	This field holds the information of mean virtual CPU usage for the EAS, see VR.VCpuUsageMean in clause 5.7.1.1.1 of 3GPP TS 28.552 [13].
Mean Virtual Memory Usage	O _M	This field holds the information of mean virtual memory usage for the EAS, see VR.VMemoryUsageMean in clause 5.7.1.2.1 of 3GPP TS 28.552 [13].
Mean Virtual Disk Usage	O _M	This field holds the information of mean virtual disk usage for the EAS, see VR.VDiskUsageMean in clause 5.7.1.2.1 of 3GPP TS 28.552 [13].
Duration Start Time	O _M	This field holds the start time of the collection period, see 3GPP TS 28.550 [14].
Duration End Time	O _M	This field holds the end time of the collection period, see 3GPP TS 28.550 [14].

6.1.2.2 Formal edge enabling infrastructure resource usage charging parameter description

6.1.2.2.1 Edge enabling infrastructure resource usage CHF CDR parameters

The detailed definitions, abstract syntax and encoding of edge enabling infrastructure resource usage CHF CDRs parameters are specified in 3GPP TS 32.298 [3].

6.1.2.2.2 Edge enabling infrastructure resource usage resources attributes

The detailed definitions of resources attributes used for edge enabling infrastructure resource usage charging are specified in 3GPP TS 32.291 [7].

6.1.2.3 Detailed message format for converged charging

The following clause specifies per Operation Type the charging data that are sent by CEF for edge enabling infrastructure resource usage converged charging.

The Operation Types are listed in the following order: I (Initial)/U (Update)/T (Termination)/E (Event). Therefore, when all Operation Types are possible it is marked as IUTE. If only some Operation Types are allowed for a node, only the appropriate letters are used (i.e. IUT or E) as indicated in the table heading. The omission of an Operation Type for a particular field is marked with "-" (i.e. IU-E). Also, when an entire field is not allowed in a node the entire cell is marked as "-".

Table 6.1.2.3-1 defines the basic structure of the supported fields in the *Charging Data Request* message for edge enabling infrastructure resource usage converged charging.

Table 6.1.2.3-1: Supported fields in Charging Data Request message

Information Element	Functionality of CEF	Edge enabling infrastructure resource usage charging
	Supported Operation Types	E
Session Identifier		-
Subscriber Identifier		-
NF Consumer Identification		E
NF Functionality		E
NF Name		E
NF Address		E
NF PLMN ID		E
Charging Identifier		E
Invocation Timestamp		E
Invocation Sequence Number		-
Retransmission Indicator		E
One-time Event		E
One-time Event Type		E
Notify URI		-
Supported Features		E
Service Specification Information		E
Triggers		E
Multiple Unit Usage		E
Rating Group		-
Requested Unit		-
Time		-
Total Volume		-
Uplink Volume		-
Downlink Volume		-
Service Specific Units		-
Used Unit Container		E
Service Identifier		E
Quota management Indicator		-
Triggers		E
Trigger Timestamp		E
Time		E
Total Volume		-
Uplink Volume		E
Downlink Volume		E
Service Specific Unit		-
Event Time Stamps		-
Local Sequence Number		-
EAS ID		E
EDN ID		E
EAS Provider Identifier		E
Edge Enabling Infrastructure Resource Usage Charging Information		E

Table 6.1.2.3-2 defines the basic structure of the supported fields in the *Charging Data Response* message for edge enabling infrastructure resource usage converged charging.

Table 6.1.2.3-2: Supported fields in Charging Data Response message

Information Element	Functionality of CEF	Edge enabling infrastructure resource usage charging
	Supported Operation Types	E
Session Identifier		E
Invocation Timestamp		E
Invocation Result		E
Invocation Result Code		E
Failed parameter		E
Failure Handling		E
Invocation Sequence Number		-
Session Failover		-
Supported Features		E
Triggers		-
Multiple Unit Information		-
Result Code		-
Rating Group		-
Granted Unit		-
Tariff Time Change		-
Time		-
Total Volume		-
Uplink Volume		-
Downlink Volume		-
Service Specific Units		-
Validity Time		-
Final Unit Indication		-
Time Quota Threshold		-
Volume Quota Threshold		-
Unit Quota Threshold		-
Quota Holding Time		-
Triggers		-

6.1.3 Bindings for edge enabling infrastructure resource usage converged charging

The mapping between the Information Elements, resource attributes and CHF CDR parameters for edge enabling infrastructure resource usage converged charging is described in 3GPP TS 32.291 [7].

6.2 Definition of charging information for EAS deployment charging

6.2.1 Data description for EAS deployment charging

6.2.1.1 Message contents

6.2.1.1.1 General

The Charging Data Request and Charging Data Response are specified in 3GPP TS 32.290 [6] and include charging information. The Charging Data Request can be of type [Event].

Table 6.2.1.1.1-1 describes the use of these messages for converged charging.

Table 6.2.1.1.1-1: Converged charging messages reference table

Message	Source	Destination
Charging Data Request	CEF	CHF
Charging Data Response	CHF	CEF

The following clauses describe the different fields used in the Charging Data messages and the category in the tables is used according to the charging data configuration defined in clause 5.4 of 3GPP TS 32.240 [2].

6.2.1.1.2 Charging Data Request message

Table 6.2.1.1.2-1 illustrates the basic structure of a Charging Data Request message from the CEF as used for EAS deployment converged charging.

Table 6.2.1.1.2-1: Charging Data Request message contents

Information Element	Converged Charging Category	Description
Session Identifier	-	This field is not applicable.
Subscriber Identifier	-	This field is not applicable.
NF Consumer Identification	M	Described in 3GPP TS 32.290 [6].
NF Functionality	M	Described in 3GPP TS 32.290 [6].
NF Name	O _C	Described in 3GPP TS 32.290 [6].
NF Address	O _C	Described in 3GPP TS 32.290 [6].
NF PLMN ID	O _C	Described in 3GPP TS 32.290 [6].
Charging Identifier	O _M	Described in 3GPP TS 32.290 [6].
Invocation Timestamp	M	Described in 3GPP TS 32.290 [6].
Invocation Sequence Number	-	This field is not applicable.
Retransmission Indicator	O _C	Described in 3GPP TS 32.290 [6].
One-time Event	O _C	Described in 3GPP TS 32.290 [6].
One-time Event Type	O _C	Described in 3GPP TS 32.290 [6].
Notify URI	-	This field is not applicable.
Supported Features	O _C	Described in 3GPP TS 32.290 [6].
Service Specification Information	O _C	Described in 3GPP TS 32.290 [6].
Triggers	O _C	Described in 3GPP TS 32.290 [6].
Multiple Unit Usage	O _M	Described in 3GPP TS 32.290 [6].
Rating Group	O _M	Described in 3GPP TS 32.290 [6].
Requested Unit	-	This field is not applicable.
Used Unit Container	-	This field is not applicable.
EAS ID	O _M	This field holds the EAS ID, see 3GPP TS 23.558 [9].
EDN ID	O _M	This field holds the DN of EdgeDataNetwork MOI, see 3GPP TS 28.538 [12].
EAS Provider Identifier	O _M	The identifier of the ASP that provides the EAS, see 3GPP TS 23.558 [9].
EAS Deployment Charging Information	O _M	This field holds the for EAS deployment charging specific information described in clause 6.2.2.1.2.

6.2.1.1.3 Charging data response message

Table 6.2.1.1.3-1 illustrates the basic structure of a Charging Data Response message from the CHF as used for EAS deployment converged charging.

Table 6.2.1.1.3-1: Charging Data Response message contents

Information Element	Converged Charging Category	Description
Session Identifier	M	Described in 3GPP TS 32.290 [6].
Invocation Timestamp	M	Described in 3GPP TS 32.290 [6].
Invocation Result	O _c	Described in 3GPP TS 32.290 [6].
Invocation Result Code	O _c	Described in 3GPP TS 32.290 [6].
Failed parameter	O _c	Described in 3GPP TS 32.290 [6].
Failure Handling	O _c	Described in 3GPP TS 32.290 [6].
Invocation Sequence Number	-	This field is not applicable.
Session Failover	-	This field is not applicable.
Supported Features	O _c	Described in 3GPP TS 32.290 [6].
Triggers	-	This field is not applicable.
Multiple Unit Information	O _c	Described in 3GPP TS 32.290 [6].
Result Code	O _c	Described in 3GPP TS 32.290 [6].
Rating Group	-	This field is not applicable.
Granted Unit	-	This field is not applicable.
Validity Time	-	This field is not applicable.
Final Unit Indication	-	This field is not applicable.
Time Quota Threshold	-	This field is not applicable.
Volume Quota Threshold	-	This field is not applicable.
Unit Quota Threshold	-	This field is not applicable.
Quota Holding Time	-	This field is not applicable.
Triggers	-	This field is not applicable.

6.2.1.2 Ga message contents

See clause 5.2.3.4.

6.2.1.3 CDR description on the Bee interface

6.2.1.3.1 General

This clause describes the CDR content and format generated for EAS deployment charging.

The following tables provide a brief description of each CDR parameter. The category in the tables is used according to the charging data configuration defined in clause 5.4 of 3GPP TS 32.240 [2]. Full definitions of the CDR parameters, sorted by the name in alphabetical order, are provided in 3GPP TS 32.298 [3].

6.2.1.3.2 EAS deployment charging CHF CDR data

If enabled, CHF CDRs for EAS deployment charging shall be produced for each EAS LCM notification (i.e. `notifyMOICreation`, `notifyMOIAttributeValueChanges`, or `notifyMOIDeletion`).

The fields of EAS deployment charging CHF CDR are specified in table 6.2.1.3.2-1.

Table 6.2.1.3.2-1: EAS deployment charging CHF record data

Field	Category	Description
Record Type	M	Described in 3GPP TS 32.298 [3]
Recording Network Function ID	O _M	Described in 3GPP TS 32.298 [3]
Tenant Identifier	O _M	Described in 3GPP TS 32.298 [3]
MnS Consumer Identifier	O _C	Described in 3GPP TS 32.298 [3]
NF Consumer Information	M	This field holds the information of the CEF that used the charging service.
NF Functionality	M	This field contains the function of the node (i.e. CEF)
NF Name	O _C	This field holds the name of the CEF used.
NF Address	O _C	This fields holds the IP Address of the CEF used.
NF PLMN ID	O _C	This field holds the PLMN identifier (MCC MNC) of the CEF.
Charging Identifier	O _M	Described in 3GPP TS 32.298 [3]
Triggers	O _M	Described in 3GPP TS 32.298 [3]
List of Multiple Unit Usage	O _M	Described in 3GPP TS 32.298 [3]
Rating Group	O _M	Described in 3GPP TS 32.298 [3]
Duration	M	Described in 3GPP TS 32.298 [3]
Record Sequence Number	C	Described in 3GPP TS 32.298 [3]
Cause for Record Closing	M	Described in 3GPP TS 32.298 [3]
Local Record Sequence Number	O _M	Described in 3GPP TS 32.298 [3]
Record Extensions	O _C	Described in 3GPP TS 32.298 [3]
Service Specification Information	O _C	Described in 3GPP TS 32.298 [3]
EAS ID	O _M	This field holds the EAS ID, see 3GPP TS 23.558 [9].
EDN ID	O _M	This field holds the DN of EdgeDataNetwork MOI, see 3GPP TS 28.538 [12].
EAS Provider Identifier	O _M	The identifier of the ASP that provides the EAS, see 3GPP TS 23.558 [9].
EAS Deployment Charging Information	O _M	This field holds the EAS deployment charging specific information defined in clause 6.2.2.1.2.

6.2.2 EAS deployment charging specific parameters

6.2.2.1 Definition of EAS deployment charging information

6.2.2.1.1 General

The Charging Information parameter used for EAS deployment charging is provided in the following clauses.

6.2.2.1.2 Definition of EAS deployment specific charging information

Specific charging information used for EAS deployment charging is provided within the EAS Deployment Charging Information.

The detailed structure of the EAS Deployment Charging Information can be found in table 6.2.2.1.2-1.

Table 6.2.2.1.2-1: Structure of EAS Deployment Charging Information

Information Element	Category	Description
EAS Deployment Requirements	O _C	This field holds the EAS Deployment Requirements, see 3GPP TS 28.538 [12], including the Required EAS Serving Location, Software Image Info, Affinity Anti Affinity ,Service Continuity and virtual Resource.
LCM Start Time	M	This field holds the start time of the EAS LCM process, see Start Time in clause 8.3.6.5 Type measJobInfo-ResourceType in 3GPP TS 28.550 [14].
LCM End Time	M	This field holds the end time of the EAS LCM process, see Stop Time in clause 8.3.6.5 Type measJobInfo-ResourceType in 3GPP TS 28.550 [14].

6.2.2.2 Formal EAS deployment charging parameter description

6.2.2.2.1 EAS deployment CHF CDR parameters

The detailed definitions, abstract syntax and encoding of EAS deployment CHF CDRs parameters are specified in 3GPP TS 32.298 [3].

6.2.2.2.2 EAS deployment resources attributes

The detailed definitions of resources attributes used for EAS deployment charging are specified in 3GPP TS 32.291 [7].

6.2.2.3 Detailed message format for converged charging

The following clause specifies per Operation Type the charging data that are sent by CEF for EAS deployment converged charging.

The Operation Types are listed in the following order: I (Initial)/U (Update)/T (Termination)/E (Event). Therefore, when all Operation Types are possible it is marked as IUTE. If only some Operation Types are allowed for a node, only the appropriate letters are used (i.e. IUT or E) as indicated in the table heading. The omission of an Operation Type for a particular field is marked with "-" (i.e. IU-E). Also, when an entire field is not allowed in a node the entire cell is marked as "-".

Table 6.2.2.3-1 defines the basic structure of the supported fields in the *Charging Data Request* message for EAS deployment converged charging.

Table 6.2.2.3-1: Supported fields in Charging Data Request message

Information Element	Functionality of CEF	EAS deployment charging
	Supported Operation Types	E
Session Identifier		-
Subscriber Identifier		-
NF Consumer Identification		E
NF Functionality		E
NF Name		E
NF Address		E
NF PLMN ID		E
Charging Identifier		E
Invocation Timestamp		E
Invocation Sequence Number		-
Retransmission Indicator		E
One-time Event		E
One-time Event Type		E
Notify URI		-
Supported Features		E
Service Specification Information		E
Triggers		E
Multiple Unit Usage		E
Rating Group		E
Requested Unit		-
Time		-
Total Volume		-
Uplink Volume		-
Downlink Volume		-
Service Specific Units		-
Used Unit Container		-
Service Identifier		-
Quota management Indicator		-
Triggers		-
Trigger Timestamp		-
Time		-
Total Volume		-
Uplink Volume		-

Information Element	Functionality of CEF	EAS deployment charging
	Supported Operation Types	E
Downlink Volume		-
Service Specific Unit		-
Event Time Stamps		-
Local Sequence Number		-
EAS ID		E
EDN ID		E
EAS Provider Identifier		E
Edge Enabling Infrastructure Resource Usage Charging Information		E

Table 6.2.2.3-2 defines the basic structure of the supported fields in the *Charging Data Response* message for EAS deployment converged charging.

Table 6.2.2.3-2: Supported fields in Charging Data Response message

Information Element	Functionality of CEF	EAS deployment charging
	Supported Operation Types	E
Session Identifier		E
Invocation Timestamp		E
Invocation Result		E
Invocation Result Code		E
Failed parameter		E
Failure Handling		E
Invocation Sequence Number		-
Session Failover		-
Supported Features		E
Triggers		-
Multiple Unit Information		-
Result Code		-
Rating Group		-
Granted Unit		-
Tariff Time Change		-
Time		-
Total Volume		-
Uplink Volume		-
Downlink Volume		-
Service Specific Units		-
Validity Time		-
Final Unit Indication		-
Time Quota Threshold		-
Volume Quota Threshold		-
Unit Quota Threshold		-
Quota Holding Time		-
Triggers		-

6.2.3 Bindings for EAS deployment converged charging

The mapping between the Information Elements, resource attributes and CHF CDR parameters for EAS deployment converged charging is described in 3GPP TS 32.291 [7].

6.3 Definition of charging information for edge enabling services charging

6.3.1 Data description for edge enabling services charging

6.3.1.1 Message contents

6.3.1.1.1 General

The Charging Data Request and Charging Data Response are specified in 3GPP TS 32.290 [6] and include charging information. The Charging Data Request can be of type [Event].

Table 6.3.1.1.1-1 describes the use of these messages for converged charging.

Table 6.3.1.1.1-1: Converged charging messages reference table

Message	Source	Destination
Charging Data Request	EES	CHF
Charging Data Response	CHF	EES

The following clauses describe the different fields used in the Charging Data messages and the category in the tables is used according to the charging data configuration defined in clause 5.4 of 3GPP TS 32.240 [2].

6.3.1.1.2 Charging data request message

Table 6.3.1.1.2-1 illustrates the basic structure of a Charging Data Request message from the EES as used for edge enabling services converged charging.

Table 6.3.1.1.2-1: Charging Data Request message contents

Information Element	Converged Charging Category	Description
Session Identifier	-	This field is not applicable.
Subscriber Identifier	-	This field is not applicable.
NF Consumer Identification	M	Described in 3GPP TS 32.290 [6].
NF Functionality	M	Described in 3GPP TS 32.290 [6].
NF Name	O _C	Described in 3GPP TS 32.290 [6].
NF Address	O _C	Described in 3GPP TS 32.290 [6].
NF PLMN ID	O _C	Described in 3GPP TS 32.290 [6].
Charging Identifier	O _M	Described in 3GPP TS 32.290 [6].
Invocation Timestamp	M	Described in 3GPP TS 32.290 [6].
Invocation Sequence Number	-	This field is not applicable.
Retransmission Indicator	O _C	Described in 3GPP TS 32.290 [6].
One-time Event	O _C	Described in 3GPP TS 32.290 [6].
One-time Event Type	O _C	Described in 3GPP TS 32.290 [6].
Notify URI	-	This field is not applicable.
Supported Features	O _C	Described in 3GPP TS 32.290 [6].
Service Specification Information	O _C	Described in 3GPP TS 32.290 [6].
Triggers	O _C	Described in 3GPP TS 32.290 [6].
Multiple Unit Usage	O _M	Described in 3GPP TS 32.290 [6].
Rating Group	O _M	Described in 3GPP TS 32.290 [6].
Requested Unit	-	This field is not applicable.
Used Unit Container	-	This field is not applicable.
EAS ID	O _M	This field holds the EAS ID, see 3GPP TS 23.558 [9].
EAS Provider Identifier	O _M	The identifier of the ASP that provides the EAS, see 3GPP TS 23.558 [9].
Direct Edge Enabling Service Charging Information	O _M	This field holds the charging information described in clause 6.3.2.1.2 specific for charging of the edge enabling services directly provided by EES, used if structured charging information is required.

Information Element	Converged Charging Category	Description
Exposed Edge Enabling Service Charging Information	O _M	This field is mapped to the NEF API Charging information defined in 3GPP TS 32.254 [16], clause 6.3.1.4, and holds the charging information described in clause 6.3.2.1.3.

6.3.1.1.3 Charging data response message

Table 6.3.1.1.3-1 illustrates the basic structure of a Charging Data Response message from the CHF as used for edge enabling services converged charging.

Table 6.3.1.1.3-1: Charging Data Response message contents

Information Element	Converged Charging Category	Description
Session Identifier	M	Described in 3GPP TS 32.290 [6].
Invocation Timestamp	M	Described in 3GPP TS 32.290 [6].
Invocation Result	O _C	Described in 3GPP TS 32.290 [6].
Invocation Result Code	O _C	Described in 3GPP TS 32.290 [6].
Failed parameter	O _C	Described in 3GPP TS 32.290 [6].
Failure Handling	O _C	Described in 3GPP TS 32.290 [6].
Invocation Sequence Number	-	This field is not applicable.
Session Failover	-	This field is not applicable.
Supported Features	O _C	Described in 3GPP TS 32.290 [6].
Triggers	-	Described in 3GPP TS 32.290 [6].
Multiple Unit Information	O _C	Described in 3GPP TS 32.290 [6].
Result Code	O _C	Described in 3GPP TS 32.290 [6].
Rating Group	-	This field is not applicable.
Granted Unit	-	This field is not applicable.
Validity Time	-	This field is not applicable.
Final Unit Indication	-	This field is not applicable.
Time Quota Threshold	-	This field is not applicable.
Volume Quota Threshold	-	This field is not applicable.
Unit Quota Threshold	-	This field is not applicable.
Quota Holding Time	-	This field is not applicable.
Triggers	-	This field is not applicable.

6.3.1.2 Ga message contents

See clause 5.2.4.4.

6.3.1.3 CDR description on the Bee interface

6.3.1.3.1 General

This clause describes the CDR content and format generated for edge enabling services charging.

The following tables provide a brief description of each CDR parameter. The category in the tables is used according to the charging data configuration defined in clause 5.4 of 3GPP TS 32.240 [2]. Full definitions of the CDR parameters, sorted by the name in alphabetical order, are provided in 3GPP TS 32.298 [3].

6.3.1.3.2 Edge enabling services charging CHF CDR data

If enabled, CHF CDRs for edge enabling services charging shall be produced for each triggering event.

The fields of edge enabling services charging CHF CDR are specified in table 6.3.1.3.2-1.

Table 6.3.1.3.2-1: Edge enabling services charging CHF record data

Field	Category	Description
Record Type	M	Described in 3GPP TS 32.298 [3].
Recording Network Function ID	O _M	Described in 3GPP TS 32.298 [3].
Tenant Identifier	O _M	Described in 3GPP TS 32.298 [3].
MnS Consumer Identifier	O _C	Described in 3GPP TS 32.298 [3].
NF Consumer Information	M	This field holds the information of the EES that used the charging service.
NF Functionality	M	This field contains the function of the node (i.e. EES).
NF Name	O _C	This field holds the name of the EES used.
NF Address	O _C	This fields holds the IP Address of the EES used.
NF PLMN ID	O _C	This field holds the PLMN identifier (MCC MNC) of the EES.
Charging Identifier	O _M	Described in 3GPP TS 32.298 [3].
Triggers	O _M	Described in 3GPP TS 32.298 [3].
List of Multiple Unit Usage	O _M	Described in 3GPP TS 32.298 [3].
Rating Group	O _M	Described in 3GPP TS 32.298 [3].
Duration	M	Described in 3GPP TS 32.298 [3].
Record Sequence Number	C	Described in 3GPP TS 32.298 [3].
Cause for Record Closing	M	Described in 3GPP TS 32.298 [3].
Local Record Sequence Number	O _M	Described in 3GPP TS 32.298 [3].
Record Extensions	O _C	Described in 3GPP TS 32.298 [3].
Service Specification Information	O _C	Described in 3GPP TS 32.298 [3].
EAS ID	O _M	This field holds the EAS ID, see 3GPP TS 23.558 [9].
EAS Provider Identifier	O _M	The identifier of the ASP that provides the EAS, see 3GPP TS 23.558 [9].
Direct Edge Enabling Service Charging Information	O _M	This field holds the charging information described in clause 6.3.2.1.2 specific for charging of the edge enabling services directly provided by EES, may be used if structured charging information is required.
Exposed Edge Enabling Service Charging Information	O _M	This field is mapped to the NEF API Charging information defined in 3GPP TS 32.254 [16], clause 6.3.1.4, and holds the charging information described in clause 6.3.2.1.3.

6.3.2 Edge enabling services charging specific parameters

6.3.2.1 Definition of edge enabling services charging information

6.3.2.1.1 General

The Charging Information parameter used for edge enabling services charging is provided in the following clauses.

6.3.2.1.2 Definition of direct edge enabling services charging specific charging information

Specific charging information used for edge enabling services charging of EAS registration, EAS discovery, ACR, ACR status, AC information, is provided within the Edge Enabling Service Charging Information, specified in 3GPP TS 23.558 [9], clause 8. May be used detailed information is required, otherwise Edge Enabling Service specific charging information clause 6.3.1.2.1.3 shall be used.

The detailed structure of the Edge Enabling Service Charging Information is described in table 6.3.2.1.2-1, and it reuses the structure of the "NEF API Charging Information" defined in 3GPP TS 32.254 [16], table 6.3.1.4.1.

Table 6.3.2.1.2-1: Structure of Direct Edge Enabling Service Charging Information

Direct Edge Enabling Service Charging Information	Category	Description
External Individual Identifier	O _c	The identifier of the UE (i.e. GSI or identity token), see 3GPP TS 23.558 [9].
External Group Identifier	-	This field is not applicable.
Internal Group Identifier	-	This field is not applicable.
API Direction	M	Described in 3GPP TS 32.254 [16], table 6.3.1.4.1.
API Target Network Function	O _c	This field holds the identifier of the network function or type of server that either is the destination of the API invocation or triggers the notification, see 3GPP TS 32.254 [16], table 6.3.1.4.1.
API Result Code	O _c	Described in 3GPP TS 32.254 [16], table 6.3.1.4.1.
API Name	M	This field holds the name of the API invoked, see 3GPP TS 23.558 [9], table 6.7.2-2.
API Reference	O _c	This field holds the reference to 3GPP TS 29.558 [17], either as the TS number and release (e.g. "3GPP TS 29.558 Rel-17") or the URI to the specification.
API Content	O _c	Described in 3GPP TS 29.558 [17], see also 3GPP TS 32.254 [16], table 6.3.1.4.1.

6.3.2.1.3 Definition of exposed Edge Enabling Service specific charging information

Specific charging information used for exposed Edge Enabling service charging is provided within the Exposed Edge Enabling Service Charging Information.

The detailed structure of the Exposed Edge Enabling Service Charging Information is described in table 6.3.2.1.3-1 and it reuses the "NEF API Charging Information" defined in 3GPP TS 32.254 [16], table 6.3.1.4.1.

Table 6.3.2.1.3-1: Structure of Exposed Edge Enabling Service Charging Information

Exposed Edge Enabling Service Charging Information	Category	Description
External Individual Identifier	O _c	The identifier of the UE (i.e. GSI or identity token), see 3GPP TS 23.558 [9].
External Group Identifier	-	This field is not applicable.
Internal Group Identifier	-	This field is not applicable.
API Direction	M	Described in 3GPP TS 32.254 [16], table 6.3.1.4.1.
API Target Network Function	O _c	This field holds the identifier of the network function or type of server that either is the destination of the API invocation or triggers the notification, see 3GPP TS 32.254 [16], table 6.3.1.4.1.
API Result Code	O _c	Described in 3GPP TS 32.254 [16], table 6.3.1.4.1.
API Name	M	This field holds the name of the API invoked, see 3GPP TS 23.558 [9], table 6.7.2-2.
API Reference	O _c	This field holds the reference to 3GPP TS 29.558 [17], either as the TS number and release (e.g. "3GPP TS 29.558 Rel-17") or the URI to the specification.
API Content	O _c	Described in 3GPP TS 29.558 [17], see also 3GPP TS 32.254 [16], table 6.3.1.4.1.

6.3.2.2 Formal edge enabling services charging parameter description

6.3.2.2.1 Edge enabling services CHF CDR parameters

The detailed definitions, abstract syntax and encoding of edge enabling services CHF CDRs parameters are specified in 3GPP TS 32.298 [3].

6.3.2.2.2 Edge enabling services resources attributes

The detailed definitions of resources attributes used for edge enabling services charging are specified in 3GPP TS 32.291 [7].

6.3.2.3 Detailed message format for converged charging

The following clause specifies per Operation Type the charging data that are sent by EES for edge enabling services converged charging.

The Operation Types are listed in the following order: I (Initial)/U (Update)/T (Termination)/E (Event). Therefore, when all Operation Types are possible it is marked as IUTE. If only some Operation Types are allowed for a node, only the appropriate letters are used (i.e. IUT or E) as indicated in the table heading. The omission of an Operation Type for a particular field is marked with "-" (i.e. IU-E). Also, when an entire field is not allowed in a node the entire cell is marked as "-".

Table 6.3.2.3-1 defines the basic structure of the supported fields in the *Charging Data Request* message for edge enabling services converged charging.

Table 6.3.2.3-1: Supported fields in Charging Data Request message

Information Element	Functionality of EES	Edge enabling services charging
	Supported Operation Types	E
Session Identifier		-
Subscriber Identifier		-
NF Consumer Identification		E
NF Functionality		E
NF Name		E
NF Address		E
NF PLMN ID		E
Charging Identifier		E
Invocation Timestamp		E
Invocation Sequence Number		-
Retransmission Indicator		E
One-time Event		E
One-time Event Type		E
Notify URI		-
Supported Features		E
Service Specification Information		E
Triggers		E
Multiple Unit Usage		-
Rating Group		-
Requested Unit		-
Time		-
Total Volume		-
Uplink Volume		-
Downlink Volume		-
Service Specific Units		-
Used Unit Container		-
Service Identifier		-
Quota management Indicator		-
Triggers		-
Trigger Timestamp		-
Time		-
Total Volume		-
Uplink Volume		-
Downlink Volume		-
Service Specific Unit		-
Event Time Stamps		-
Local Sequence Number		-
EAS ID		E
EAS Provider Identifier		E
Direct Edge Enabling Service Charging Information		E
Exposed Edge Enabling Service Charging Information		E

Table 6.3.2.3-2 defines the basic structure of the supported fields in the *Charging Data Response* message for edge enabling services converged charging.

Table 6.3.2.3-2: Supported fields in Charging Data Response message

Information Element	Functionality of EES	Edge enabling services charging
	Supported Operation Types	E
Session Identifier		E
Invocation Timestamp		E
Invocation Result		E
Invocation Result Code		E
Failed parameter		E
Failure Handling		E
Invocation Sequence Number		-
Session Failover		-
Supported Features		E
Triggers		-
Multiple Unit Information		-
Result Code		-
Rating Group		-
Granted Unit		-
Tariff Time Change		-
Time		-
Total Volume		-
Uplink Volume		-
Downlink Volume		-
Service Specific Units		-
Validity Time		-
Final Unit Indication		-
Time Quota Threshold		-
Volume Quota Threshold		-
Unit Quota Threshold		-
Quota Holding Time		-
Triggers		-

6.3.3 Bindings for edge enabling services converged charging

The mapping between the Information Elements, resource attributes and CHF CDR parameters for edge enabling services converged charging is described in 3GPP TS 32.291 [7].

Annex A (informative): Change history

Change history							
Date	Meeting	TDoc	CR	Re v	Cat	Subject/Comment	New version
2022-06	SA#96					Upgrade to change control version	17.0.0
2022-06	SA#96					EditHelp review	17.0.1
2022-06	SA#96	SP-220868	0001	-	F	Correction on reference for the EAS Deployment	17.1.0
2022-06	SA#96	SP-220868	0002	-	F	Correction on the mapping between EC and NEF	17.1.0
2022-06	SA#96	SP-220868	0003	-	F	Correction on the detailed message format for converged charging	17.1.0

History

Document history		
V17.0.1	July 2022	Publication
V17.1.0	October 2022	Publication