

# ETSI TS 132 272 V16.0.0 (2020-08)



**Digital cellular telecommunications system (Phase 2+) (GSM);  
Universal Mobile Telecommunications System (UMTS);  
LTE;  
Telecommunication management;  
Charging management;  
Push-to-talk over Cellular (PoC) charging  
(3GPP TS 32.272 version 16.0.0 Release 16)**



---

**Reference**

RTS/TSGS-0532272vg00

---

**Keywords**

GSM,LTE,UMTS

**ETSI**

650 Route des Lucioles  
F-06921 Sophia Antipolis Cedex - FRANCE

---

Tel.: +33 4 92 94 42 00 Fax: +33 4 93 65 47 16

Siret N° 348 623 562 00017 - NAF 742 C  
Association à but non lucratif enregistrée à la  
Sous-Préfecture de Grasse (06) N° 7803/88

---

**Important notice**

---

The present document can be downloaded from:

<http://www.etsi.org/standards-search>

The present document may be made available in electronic versions and/or in print. The content of any electronic and/or print versions of the present document shall not be modified without the prior written authorization of ETSI. In case of any existing or perceived difference in contents between such versions and/or in print, the prevailing version of an ETSI deliverable is the one made publicly available in PDF format at [www.etsi.org/deliver](http://www.etsi.org/deliver).

Users of the present document should be aware that the document may be subject to revision or change of status.

Information on the current status of this and other ETSI documents is available at

<https://portal.etsi.org/TB/ETSIDeliverableStatus.aspx>

If you find errors in the present document, please send your comment to one of the following services:

<https://portal.etsi.org/People/CommitteeSupportStaff.aspx>

---

**Copyright Notification**

---

No part may be reproduced or utilized in any form or by any means, electronic or mechanical, including photocopying and microfilm except as authorized by written permission of ETSI.

The content of the PDF version shall not be modified without the written authorization of ETSI.

The copyright and the foregoing restriction extend to reproduction in all media.

© ETSI 2020.

All rights reserved.

**DECT™**, **PLUGTESTS™**, **UMTS™** and the ETSI logo are trademarks of ETSI registered for the benefit of its Members.

**3GPP™** and **LTE™** are trademarks of ETSI registered for the benefit of its Members and of the 3GPP Organizational Partners.

**oneM2M™** logo is a trademark of ETSI registered for the benefit of its Members and of the oneM2M Partners.

**GSM®** and the GSM logo are trademarks registered and owned by the GSM Association.

---

## Intellectual Property Rights

### Essential patents

IPRs essential or potentially essential to normative deliverables may have been declared to ETSI. The information pertaining to these essential IPRs, if any, is publicly available for **ETSI members and non-members**, and can be found in ETSI SR 000 314: "*Intellectual Property Rights (IPRs); Essential, or potentially Essential, IPRs notified to ETSI in respect of ETSI standards*", which is available from the ETSI Secretariat. Latest updates are available on the ETSI Web server (<https://ipr.etsi.org/>).

Pursuant to the ETSI IPR Policy, no investigation, including IPR searches, has been carried out by ETSI. No guarantee can be given as to the existence of other IPRs not referenced in ETSI SR 000 314 (or the updates on the ETSI Web server) which are, or may be, or may become, essential to the present document.

### Trademarks

The present document may include trademarks and/or tradenames which are asserted and/or registered by their owners. ETSI claims no ownership of these except for any which are indicated as being the property of ETSI, and conveys no right to use or reproduce any trademark and/or tradename. Mention of those trademarks in the present document does not constitute an endorsement by ETSI of products, services or organizations associated with those trademarks.

---

## Legal Notice

This Technical Specification (TS) has been produced by ETSI 3rd Generation Partnership Project (3GPP).

The present document may refer to technical specifications or reports using their 3GPP identities. These shall be interpreted as being references to the corresponding ETSI deliverables.

The cross reference between 3GPP and ETSI identities can be found under <http://webapp.etsi.org/key/queryform.asp>.

---

## Modal verbs terminology

In the present document "**shall**", "**shall not**", "**should**", "**should not**", "**may**", "**need not**", "**will**", "**will not**", "**can**" and "**cannot**" are to be interpreted as described in clause 3.2 of the [ETSI Drafting Rules](#) (Verbal forms for the expression of provisions).

"**must**" and "**must not**" are **NOT** allowed in ETSI deliverables except when used in direct citation.

# Contents

Intellectual Property Rights .....	2
Legal Notice .....	2
Modal verbs terminology.....	2
Foreword.....	5
1 Scope .....	6
2 References .....	7
3 Definitions, symbols and abbreviations .....	9
3.1 Definitions .....	9
3.2 Symbols.....	14
3.3 Abbreviations .....	16
4 Architecture considerations .....	20
4.1 High level PoC architecture.....	20
4.1.1 PoC functional entities.....	21
4.1.1.1 PoC Client .....	21
4.1.1.2 PoC Server .....	21
4.2 PoC offline charging architecture.....	24
4.3 PoC online charging architecture .....	24
5 PoC charging principles and scenarios.....	25
5.0 General .....	25
5.1 PoC charging principles .....	25
5.1.1 PoC session related charging .....	25
5.1.2 PoC session unrelated charging .....	27
5.1.3 Charging based on number of participants .....	27
5.2 PoC offline charging scenarios.....	28
5.2.0 General.....	28
5.2.1 Basic principles.....	28
5.2.2 Message flows .....	28
5.2.2.1 Message flows - Successful cases and scenarios.....	28
5.2.2.1.1 Successful PoC session establishment.....	28
5.2.2.1.2 PoC talk burst exchange .....	30
5.2.2.1.3 Instant personal alert.....	30
5.2.2.1.4 Pre-established session set-up .....	31
5.2.2.1.5 Mid PoC session procedures.....	31
5.2.3 CDR generation .....	32
5.2.4 GTP' record transfer flows.....	32
5.2.5 B <sub>T</sub> CDR file transfer .....	32
5.3 PoC online charging scenarios .....	32
5.3.1 Basic principles.....	32
5.3.2 Diameter message flows .....	33
5.3.2.1 Successful PoC session establishment .....	33
5.3.2.2 PoC talk burst exchange.....	34
5.3.2.3 Instant personal alert .....	35
5.3.2.4 Early session set-up.....	36
5.3.2.5 Participant number based charging .....	37
5.3.2.6 Participating type based charging .....	38
6 Definition of charging information .....	40
6.1 Data description for PoC offline charging.....	40
6.1.0 General.....	40
6.1.1 Rf message contents.....	40
6.1.1.1 Summary of offline charging message formats.....	40
6.1.1.2 Structure for the Charging Data message formats.....	40
6.1.1.2.0 Introduction .....	40

6.1.1.2.1	Charging Data Request message .....	41
6.1.1.2.2	Charging Data Response message .....	41
6.1.2	GTP' message contents .....	41
6.1.3	CDR description on the B <sub>T</sub> interface .....	42
6.1.3.1	CDR field types.....	42
6.1.3.2	CDR triggers .....	42
6.1.3.2.1	PoC session related CDRs .....	42
6.1.3.2.2	Session unrelated CDRs .....	42
6.1.3.3	PoC CDR content.....	44
6.1.3.3.1	Participating PoC Function.....	44
6.1.3.3.2	Controlling PoC Function.....	47
6.2	Data description for PoC online charging .....	50
6.2.0	General.....	50
6.2.1	Ro message contents .....	50
Void.6.2.1.1	Debit / Reserve Units Request message .....	50
6.2.1.2	Debit / Reserve Units Response message.....	52
6.3	PoC charging specific parameters .....	53
6.3.1	Definition of the PoC charging information .....	53
6.3.1.0	General .....	53
6.3.1.1	PoC charging information assignment for Service Information.....	53
6.3.1.2	Definition of the PoC Information .....	54
6.3.2	Formal parameter description .....	55
6.3.2.1	PoC charging information for CDRs.....	55
6.3.2.2	PoC charging information for charging events .....	55
<b>Annex A (informative):</b>	<b>Bibliography.....</b>	<b>56</b>
<b>Annex B (informative):</b>	<b>Change history .....</b>	<b>57</b>
History .....		58

---

# Foreword

This Technical Specification has been produced by the 3<sup>rd</sup> Generation Partnership Project (3GPP).

The contents of the present document are subject to continuing work within the TSG and may change following formal TSG approval. Should the TSG modify the contents of the present document, it will be re-released by the TSG with an identifying change of release date and an increase in version number as follows:

Version x.y.z

where:

- x the first digit:
  - 1 presented to TSG for information;
  - 2 presented to TSG for approval;
  - 3 or greater indicates TSG approved document under change control.
- y the second digit is incremented for all changes of substance, i.e. technical enhancements, corrections, updates, etc.
- z the third digit is incremented when editorial only changes have been incorporated in the document.

---

# 1 Scope

The present document is part of a series of Technical Specifications (TSs) that specify charging functionality and charging management in GSM/UMTS networks. The GSM/UMTS core network charging architecture and principles are specified in TS 32.240 [1], which provides an umbrella for other charging management TSs that specify:

- the content of the CDRs per domain and subsystem (offline charging);
- the content of real-time charging messages per domain / subsystem (online charging);
- the functionality of online and offline charging for those domains and subsystems;
- the interfaces that are used in the charging framework to transfer the charging information (i.e. CDRs or charging events).

The complete document structure for these TSs is defined in TS 32.240 [1].

The present document specifies the offline and online charging description for the "Push-to-Talk over Cellular" (PoC) service, based on the functional description of the PoC service in TR 23.979 "3GPP enablers for OMA PoC Services" [200], in OMA-AD-POC "Push to talk over Cellular (PoC) - Architecture" [203], in OMA-CP-POC "OMA PoC Control Plane" [204] and in OMA-UP-POC: "OMA POC User Plane"[205], respectively. This charging description includes the offline and online charging architecture and scenarios specific to PoC, as well as the mapping of the common 3GPP charging architecture specified in TS 32.240 [1] onto the PoC service. It further specifies the structure and content of the CDRs for offline charging, and the charging events for online charging. The present document is related to other 3GPP charging TSs as follows:

- The common 3GPP charging architecture is specified in TS 32.240 [1];
- The parameters, abstract syntax and encoding rules for the CDRs are specified in TS 32.298 [51];
- A transaction based mechanism for the transfer of CDRs within the network is specified in TS 32.295 [54];
- The file based mechanism used to transfer the CDRs from the network to the operator's billing domain (e.g. the billing system or a mediation device) is specified in TS 32.297 [52];
- The 3GPP Diameter application that is used for PoC offline and online charging is specified in TS 32.299 [50].

All terms, definitions and abbreviations used in the present document, that are common across 3GPP TSs, are defined in the 3GPP Vocabulary, TR 21.905 [100]. Those that are common across charging management in GSM/UMTS domains or subsystems are provided in the umbrella document TS 32.240 [1] and are copied into clause 3 of the present document for ease of reading. Finally, those items that are specific to the present document are defined exclusively in the present document.

Furthermore, requirements that govern the charging work are specified in TS 22.115 [101].

---

## 2 References

The following documents contain provisions which, through reference in this text, constitute provisions of the present document.

- References are either specific (identified by date of publication, edition number, version number, etc.) or non-specific.
- For a specific reference, subsequent revisions do not apply.
- For a non-specific reference, the latest version applies. In the case of a reference to a 3GPP document (including a GSM document), a non-specific reference implicitly refers to the latest version of that document *in the same Release as the present document*.

- [1] 3GPP TS 32.240: "Telecommunication management; Charging management; Charging architecture and principles".
- [2] - [9] Void.
- [10] 3GPP TS 32.250: "Telecommunication management; Charging management; Circuit Switched (CS) domain charging".
- [11] 3GPP TS 32.251: "Telecommunication management; Charging management; Packet Switched (PS) domain charging".
- [12] - [19] Void.
- [20] 3GPP TS 32.260: "Telecommunication management; Charging management; IP Multimedia Subsystem (IMS) charging".
- [21] - [29] Void.
- [30] 3GPP TS 32.270: "Telecommunication management; Charging management; Multimedia Messaging Service (MMS) charging".
- [31] - [49] Void.
- [50] 3GPP TS 32.299: "Telecommunication management; Charging management; Diameter charging application".
- [51] 3GPP TS 32.298: "Telecommunication management; Charging management; Charging Data Record (CDR) parameter description".
- [52] 3GPP TS 32.297: "Telecommunication management; Charging management; Charging Data Record (CDR) file format and transfer".
- [53] Void.
- [54] 3GPP TS 32.295: "Telecommunication management; Charging management; Charging Data Record (CDR) transfer".
- [55] - [99] Void.
- [100] 3GPP TR 21.905: "Vocabulary for 3GPP specifications".
- [101] 3GPP TS 22.115: "Service aspects; Charging and billing".
- [102] - [199] Void.
- [200] 3GPP TR 23.979: "3GPP enablers for Open Mobile Alliance (OMA): Push-to-talk over Cellular (PoC) services; Stage 2".
- [201] 3GPP TS 23.228: "IP Multimedia Subsystem (IMS); Stage 2".
- [202] 3GPP TS 24.228: "Signalling flows for the IP multimedia call control based on Session Initiation Protocol (SIP) and Session Description Protocol (SDP); Stage 3".



- [203] OMA-AD-POC: "Push to talk over Cellular (PoC) - Architecture".
- [204] OMA-CP-POC: "OMA PoC Control Plane".
- [205] OMA-UP-POC: "OMA POC User Plane".
- [206] 3GPP TS 24.002: "GSM - UMTS Public Land Mobile Network (PLMN) Access Reference Configuration".
- [207] 3GPP TS 25.305: "Stage 2 functional specification of User Equipment (UE) positioning in UTRAN".
- [208] 3GPP TS 43.059: "Functional stage 2 description of Location Services (LCS) in GERAN".
- [209] - [300] Void.
- [301] ITU-T Recommendation Q.1001
- [302] – [402] Void.
- [403] IETF RFC 1350 (1992): "The TFTP Protocol (Revision 2)".
- [404] IETF RFC 3261(2002): "SIP: Session Initiation Protocol".
- [405] IETF RFC 3966 (2004): "The tel URI for Telephone Numbers".

## 3 Definitions, symbols and abbreviations

### 3.1 Definitions

For the purposes of the present document, the terms and definitions given in TR 21.905 [50], TS 32.240 [1] and the following apply:

**1-1 PoC session:** feature enabling a PoC user to establish a PoC session with another PoC user

**2G- / 3G-:** prefixes 2G- and 3G- refers to functionality that supports only GSM or UMTS, respectively, e.g. 2G-SGSN refers only to the GSM functionality of an SGSN

When the term/prefix is omitted, reference is made independently from the GSM or UMTS functionality.

**ad-hoc PoC group session:** feature enabling a PoC user to establish a PoC session with multiple PoC users without first creating a PoC group.

This sort of PoC session for multiple PoC users that does not involve the use or definition of a pre-arranged or chat PoC group session.

**accounting:** process of apportioning charges between the Home Environment, Serving Network and Subscriber.

**accounting meter record:** record containing one or more counters employed to register the usage of resources en masse.

Includes simple event counters and/ or cumulative call second counters.

**Advice of Charge (AoC):** real-time display of the network utilization charges incurred by the Mobile Station (MS). The charges are displayed in the form of charging units. If a unit price is stored by the MS then the display may also include the equivalent charge in the home currency.

**AoC service:** combination of one or more services, both basic and supplementary, together with a number of other charging relevant parameters to define a customized service for the purpose of Advice of Charge (AoC)

**application data:** information / data specific to an application other than the MMS User Agent / VASP which is intended to be transported without alteration by using MMS

Application Data may be of any content type and format.

**billing:** function whereby CDRs generated by the charging function are transformed into bills requiring payment.

**Billing Domain (BD):** part of the operator network, which is outside the telecommunication network, that receives and processes CDR files from the core network charging functions.

It includes functions that can provide billing mediation and billing or other (e.g. statistical) end applications.

It is only applicable to offline charging (see "Online Charging System" for equivalent functionality in online charging).

**CAMEL:** network feature that provides the mechanisms to support operator specific services even when roaming outside HPLMN.

**CAMEL subscription information:** identifies a subscriber as having CAMEL services.

**chargeable event:** activity utilizing telecommunications network infrastructure and related services for:

- user to user communication (e.g. a single call, a data communication session or a short message); or
- user to network communication (e.g. service profile administration); or
- inter-network communication (e.g. transferring calls, signalling, or short messages); or
- mobility (e.g. roaming or inter-system handover); and
- that the network operator may want to charge for.

As a minimum, a chargeable event characterises the resource / service usage and indicates the identity of the involved end user(s).

**charged party:** user involved in a chargeable event that has to pay parts or the whole charges of the chargeable event, or a third party paying the charges caused by one or all users involved in the chargeable event, or a network operator

**charging:** function within the telecommunications network and the associated OCS/BD components whereby information related to a chargeable event is collected, formatted, transferred and evaluated in order to make it possible to determine usage for which the charged party may be billed (offline charging) or the subscribers account balance may be debited (online charging)

**Charging Data Record (CDR):** formatted collection of information about a chargeable event (e.g. time of call set-up, duration of the call, amount of data transferred, etc.) for use in billing and accounting  
For each party to be charged for parts of or all charges of the chargeable event(s) a separate CDR shall be generated, i.e. more than one CDR may be generated for a single chargeable event, e.g. because of its long duration, or because more than one charged party is to be charged.

**charging destination:** also referred to as a destination for charging, this is a nominal reference defining the point of termination of a connection for charging purposes

**charging event:** set of charging information forwarded by the CTF towards the CDF (offline charging) or towards the OCS (online charging)

Each charging event matches exactly one chargeable event.

**charging function:** entity inside the core network domain, subsystem or service that is involved in charging for that domain, subsystem or service

**charging origin:** nominal reference defining the point of origin of a connection for charging purposes

**chat PoC group:** persistent group in which each member individually joins the PoC session, i.e. the establishment of a PoC session to a chat PoC group does not result in other members of the chat PoC group being invited

**chat PoC group session:** PoC session established to a chat PoC group.

In a chat PoC group, PoC subscribers shall be able to join and leave the chat PoC group session themselves. If the chat PoC group is restricted, then only group members shall be able to join.

**circuit switched domain:** domain within GSM / UMTS in which information is transferred in circuit switched mode.

**controlling PoC function:** function implemented in a PoC Server and provides centralized PoC session handling, which includes RTP media distribution, talk burst control, policy enforcement for participation in group sessions, and the participant information

**credit control:** which directly interacts in real-time with an account and controls or monitors the charges, related to the service usage

Credit control is a process of: checking if credit is available, credit reservation, deduction of credit from the end user account when service is completed and refunding of reserved credit not used.

**delivery report:** feedback information provided to an originator MMS User Agent by an MMS R/S (MMS R/S) about the status of the delivery of an MM

**domain:** part of a communication network that provides services using a certain technology

**forwarded MM:** MM originally sent from a sender to an intended recipient which is then forwarded to other recipient(s) and to which a delivery report and/or read-reply report may refer and which may be subject to further forwarding

**forwarding MMS User Agent:** MMS User Agent that is the intended recipient of an MM and that requests forwarding of the MM for delivery to other recipient(s) without having to first download the MM

**Fully qualified Partial CDR (FQPC):** partial CDR that contains a complete set of the fields specified in TS 32.272. This includes all the mandatory and conditional fields as well as those fields that the PLMN operator has provisioned to be included in the CDR. The first Partial CDR shall be a Fully qualified Partial CDR.

**GPRS:** packet switched bearer and radio services for GSM and UMTS systems.

**GTP':** GPRS protocol used for CDR transport.

It is derived from GTP with enhancements to improve transport reliability necessary for CDRs.

NOTE: This protocol is not used for tunnelling.

**GSM only:** qualifier indicating that this clause or paragraph applies only to a GSM system.  
For multi-system cases this is determined by the current serving radio access network.

**in GSM,...:** qualifier indicating that this paragraph applies only to GSM System.

**in UMTS,...:** qualifier indicating that this paragraph applies only to UMTS System.

**Instant personal alert:** feature in which a PoC user sends a SIP based instant message to a PoC user requesting a 1-1 PoC session.

**inter-system change:** change of radio access between different radio access technologies such as GSM and UMTS.

**LCS Client:** software and/or hardware entity that interacts with a LCS Server for the purpose of obtaining location information for one or more Mobile Stations (MSs).

LCS Clients subscribe to LCS in order to obtain location information. LCS Clients may or may not interact with human users. The LCS Client is responsible for formatting and presenting data and managing the user interface (dialogue). The LCS Client may reside in the Mobile Station (MS).

**LCS Server:** software and/or hardware entity offering LCS capabilities.

The LCS Server accepts requests, services requests, and sends back responses to the received requests.

The LCS Server consists of LCS components, which are distributed to one or more PLMN and/or service provider.

**Location Based Service (LBS):** service provided either by teleoperator or a 3<sup>rd</sup> party service provider that utilizes the available location information of the terminal.

Location Application offers the User Interface for the service. LBS is either a pull or a push type of service (see Location Dependent Services and Location Independent Services).

In ETSI/GSM documentation of SoLSA, LBS is called "Location Related Service".

ETSI and/or 3GPP -wide terminology harmonization is expected here.

**Location Estimate:** geographic location of an UE and/or a valid Mobile Equipment (ME), expressed in latitude and longitude data.

The Location Estimate is represented in a well-defined universal format. Translation from this universal format to another geographic location system may be supported, although the details are considered outside the scope of the primitive services.

**message ID:** unique identifier for an MM

**middle tier TS:** term used for the 3GPP charging TSs that specify the domain / subsystem / service specific, online and offline, charging functionality.

These are all the TSs in the numbering range from TS 32.250 to TS 32.27x, e.g. TS 32.250 [10] for the CS domain, or TS 32.270 [30] for the MMS service.

Currently, there is only one "tier 1" TS in 3GPP, which is TS 32.240 [1] that specifies the charging architecture and principles. Finally, there are a number of top tier TSs in the 32.29x numbering range ([50] ff) that specify common charging aspects such as parameter definitions, encoding rules, the common billing domain interface or common charging applications.

**MMSE:** collection of MMS-specific Elements under the control of a single administration.

**MMS Relay/Server (MMS R/S):** MMS-specific network entity/application that is under the control of an MMS service provider.

An MMS R/S transfers messages, provides operations of the MMS that are specific to or required by the mobile environment and provides (temporary and/or persistent) storage services to the MMS.

**MMS User Agent:** application residing on a user equipment, an MS or an external device that performs MMS-specific operations on a user's behalf and/or on another application's behalf. An MMS User Agent is not considered part of an MMSE.

**Multimedia Messaging Service Network Architecture (MMSNA):** encompasses all the various elements that provide a complete MMS to a user.

**near real-time:** near real-time charging and billing information is to be generated, processed, and transported to a desired conclusion in less than one (1) minute.

**observed IMEI ticket:** record used to describe an EIR relevant event e.g. a blacklisted IMEI.

**offline charging:** charging mechanism where charging information **does not** affect, in real-time, the service rendered.

**on-demand session:** an on-demand session is a PoC session set-up mechanism in which all media parameters are negotiated at PoC session establishment.

**online charging:** charging mechanism where charging information can affect, in real-time, the service rendered and therefore a direct interaction of the charging mechanism with session/service control is required.

**Online Charging System (OCS):** entity that performs real-time credit control.

Its functionality includes transaction handling, rating, online correlation and management of subscriber account balances.

**original MM:** (initial) MM sent from a sender to a recipient and to which a delivery report and/or a read-reply report and/or a reply-MM may refer and/or which may be subject to being forwarded.

**originator MMS User Agent:** MMS User Agent associated with the sender of an MM.

**packet switched domain:** domain within GSM and UMTS in which data is transferred in packet switched mode. It corresponds to the term "GPRS".

**partial CDR:** CDR that provides charging information on part of a subscriber session.

A long session may be covered by several partial CDRs. Two formats are considered for Partial CDRs.

One that contains all of the necessary fields; the second has a reduced format.

**participating PoC function:** function implemented in a PoC Server, and provides PoC session handling, which includes policy enforcement for incoming PoC sessions and relays talk burst control messages between the PoC Client and the PoC Server performing the controlling PoC function.

The participating PoC function may also relay RTP media between the PoC Client and the PoC Server performing the controlling PoC function.

**PoC Client:** PoC functional entity that resides on the PoC user equipment that supports the PoC service.

**PoC group:** a PoC group is a predefined set of PoC users together with its attributes. A PoC group is identified by a SIP URI.

**PoC group advertisement:** a PoC group advertisement is a feature that provides the capability to inform other PoC users of the existence of a PoC group.

**PoC group identity:** the PoC group identity is a SIP URI of the pre-arranged PoC group or chat PoC group.

**PoC Server:** implements the application level network functionality for the PoC service.

A PoC Server may perform the role of the controlling PoC function or participating PoC function, or both at the same time.

**PoC session:** the present document supports the following types of PoC sessions: 1-1 PoC session, ad-hoc PoC group session, pre-arranged PoC group session, or chat PoC group session.

**PoC session identity:** SIP URI received by the PoC Client during the PoC session establishment in the contact header and/or in the Talk Burst Control Protocol (TBCP) connect message in case of using pre-established session.

**PoC user:** user of the PoC service.

**positioning method (/locating method):** method or technical solution, which is used to get an estimate of the target mobile's geographical location.

**EXAMPLE:** Positioning methods based on radio cell coverage, GPS or Assisted GPS methods, which are based on the Time-Of-Arrival (TOA) algorithm, and OTDOA or E-OTD methods, which are based on the Time-Difference-Of-Arrival (TDOA) algorithm.  
The positioning methods are further described in UTRAN Stage 2 TS 25.305 [63] and GERAN Stage 2 TS 43.059 [64].

**pre-arranged PoC group session:** is a persistent PoC session Identity that has an associated set of PoC members. The establishment of a PoC session to a pre-arranged PoC group results in all members being invited.

**pre-established session:** signalling exchange to negotiate media parameters between the PoC Client and the home PoC Server before establishing a PoC session.

**read-reply report:** feedback information to an originator MMS User Agent by a recipient MMS User Agent about the status of handling/rendering of an original MM in a recipient MMS User Agent.

**real-time:** real-time charging and billing information is to be generated, processed, and transported to a desired conclusion in less than 1 second.

**recipient MMS User Agent:** MMS User Agent associated with the recipient of an MM.

**Reduced Partial CDR (RPC):** partial CDRs that only provide mandatory fields and information regarding changes in the session parameters relative to the previous CDR.

EXAMPLE: Location information is not repeated in these CDRs if the subscriber did not change its location.

**reply-MM:** in case of reply-charging the first reply accepted by the recipient MMS R/S (after checking the reply charging limitations, such as the latest time of submission) is called a reply-MM.

**Reporting Area:** Service Area for which an MS's location is reported.

**RTP media:** RTP media is the media carried in an RTP payload.

**Service Area:** defined in the same way as the Service Area according to ITU-T Recommendation Q.1001 [310]. In contrast to the PLMN area it is not based on the coverage of a PLMN. Instead it is based on the area in which a fixed network user can call a mobile user without knowing its location. For example, the Service Area can therefore change when the signalling system is being extended.

**settlement:** payment of amounts resulting from the accounting process.

**simultaneous PoC session:** When a PoC user is a participant in more than one PoC session simultaneously using the same PoC Client.

**subscriber:** entity (associated with one or more users) that is engaged in a subscription with a service provider. The subscriber is allowed to subscribe and unsubscribe services, to register a user or a list of users authorized to enjoy these services, and also to set the limits relative to the use that associated users make of these services.

**successful call:** connection that reaches the communication or data transfer phase e.g. the "answered" state for speech connections. All other connection attempts are regarded as unsuccessful.

**talk burst:** media recording, transport and playback that occurs from the point the PoC Client has got the permission to send media until the permission is released.

**Talk Burst Control Protocol (TBCP):** is a protocol for performing talk burst control, as defined in OMA-UP-POC: "OMA POC User Plane" [205].

**target UE:** UE being positioned.

**tariff period:** part of one (calendar) day during which a particular tariff is applied. Defined by the time at which the period commences (the switch-over time) and the tariff to be applied after switch-over.

**tariff:** set of parameters defining the network utilisation charges for the use of a particular bearer / session / service

**UMTS only:** qualifier indicating that this clause or paragraph applies only to a UMTS system. For multi-system cases this is determined by the current serving radio access network.

**user:** entity that is not part of the 3GPP system, which uses network resources by means of a subscription. The user may or may not be identical to the subscriber holding that subscription.

**User Equipment (UE):** device allowing a user access to network services. For the purpose of 3GPP specifications the interface between the UE and the network is the radio interface. An UE can be subdivided into a number of domains, the domains being separated by reference points. Currently defined domains are the USIM and ME Domains. The ME Domain can further be subdivided into several components showing the connectivity between multiple functional groups. These groups can be implemented in one or more hardware devices. An example of such a connectivity is the TE - MT interface. Further, an occurrence of a User Equipment is an MS for GSM as defined in TS 24. 002 [206].

## 3.2 Symbols

For the purposes of the present document, the following symbols apply:

A	Interface between an MSC and a BSC
Bc	Reference point for the CDR file transfer from the Circuit Switched CGF to the BD
Bi	Reference point for the CDR file transfer from the IMS CGF to the BD
Bl	Reference point for the CDR file transfer from the GMLC CGF to the BD
Bm	Reference point for the CDR file transfer from the MMS CGF to the BD
Bmb	Reference point for the CDR file transfer from the MBMS CGF to the BD
Bo	Reference point for the CDR file transfer from the OCF CGF to the BD
Bp	Reference point for the CDR file transfer from the Packet Switched CGF to the BD
Bs	Reference point for the CDR file transfer for CAMEL services to the BD, i.e. from the SCF CGF to the BD
Bt	Reference point for the CDR file transfer from the PoC CGF to the BD
Bw	Reference point for the CDR file transfer from the WLAN CGF to the BD
Bx	Reference point for CDR file transfer between any (generic) 3G domain, subsystem or service CGF and the BD
C	Interface between a HLR and a SMSC
CAP	Reference point for CAMEL between a network element with integrated SSF and the OCS
Ci	Charging trigger in combined MMS R/S
D	Interface between a MSC and a HLR
D'	Reference point between an MSCa pre-R6 HSS/HLR and a BSC.3GPP AAA Server
Dw	Reference point between a 3GPP AAA Server and an SLF
E	Interface between a MSC and a SMSC
Ga	Reference point for CDR transfer between a CDF and the CGF
Gb	Interface between an SGSN and a BSC
Gc	Interface between an GGSN and an HLR
Gd	Interface between an SMS-GMSC and an SGSN, and between a SMS-IWMSC and an SGSN
Ge	Interface between a SGSN and a CAMEL GSM SCF
Gf	Interface between an SGSN and an EIR
Gi	Interface between the Packet-Switched domain and an external packet data network
Gm	Reference point between the UE and an P-CSCF
Gn	Interface between two GSNs within the same PLMN
Gp	Interface between two GSNs in different PLMNs
Gr	Interface between an SGSN and an HLR
Gr'	Reference point between a pre-R6 HSS/HLR and a 3GPP AAA Server
Gs	Interface between an SGSN and an MSC/VLR
Gx	Reference point between a CRF and a TPF
Gy	Online charging reference point between a TPF and an OCS
Gz	Offline charging reference point between a TPF and a CDF
Iu	Interface between the RNS and the core network
kbit/s	kilobits per second. $1 \text{ kbit/s} = 2^{10} \text{ bits per second}$
Lr	Interface between Gateway MLCs
Mbit/s	Megabits per second. $1 \text{ Mbit/s} = 2^{20} \text{ bits per second}$
Mc	Interface between the MGW and (G)MSC server
Mi	Charging trigger in MMS R/S for MMBox Management
MM1	Reference point between the MMS User Agent and the MMS R/S
MM2	Reference point between the MMS Relay and the MMS Server
MM3	Reference point between the MMS R/S and external (legacy) messaging systems
MM4	Reference point between the MMS R/S and another MMS R/S that is within another MMSE
MM5	Reference point between the MMS R/S and the Home Location Register (HLR)
MM6	Reference point between the MMS R/S and the MMS User Databases
MM7	Reference point between the MMS R/S and MMS VAS Applications
MM8	Reference point between the MMS R/S and the post-processing system
MM9	Reference point between the MMS R/S and the online charging system
MM10	Reference point between the MMS R/S and a MSCF
Mw	Reference point between one CSCF and another CSCF
Oi	Charging trigger in Originator MMS R/S
R	Reference point between a non-ISDN compatible TE and MT. Typically this reference point supports a standard serial interface.

Rf	Offline charging reference point between a PoC Server and the CDF.
Ri	Charging trigger in Recipient MMS R/S
Ro	Online charging reference point between a PoC Server and the OCS
Rx	Reference point between the CRF and an AF
Um	Interface between the Mobile Station (MS) and the GSM fixed network part
Ut	Reference point between the UE and an GLMS
Uu	Interface between the Mobile Station (MS) and the UMTS fixed network part



### 3.3 Abbreviations

For the purposes of the present document, the abbreviations defined in TR 21.905 [50], TS 32.240 [1] and the following apply:

ABNF	Augmented Backus-Naur Form
ACA	ACcounting Answer
ACR	ACcounting Request
APN	Access Point Name
AF	Application Function
AMF	Account balance Management Function
AoC	Advice of Charge
APN	Access Point Name
AS	Application Server
AVP	Attribute Value Pair
B2BUA	Back-to-Back User Agent
BCF	Bearer Charging Function
BCSM	Basic Call State Model
BD	Billing Domain
BGCF	Breakout Gateway Control Function
BM-SC	Broadcast Multicast - Service Centre
BS	Billing System
BSC	Base Station Controller
BSS	Base Station Subsystem
BTS	Base Transceiver Station
CAI	Charge Advice Information
CAMEL	Customised Applications for Mobile network Enhanced Logic
CAP	CAMEL Application Part
CCA	Credit Control Answer
CCF	Charging Collection Function
CCR	Credit Control Request
CDF	Charging Data Function
CDR	Charging Data Record
CG	Charging Gateway
CGF	Charging Gateway Function
CI	Cell Identity
CRF	Charging Rules Function
CS	Circuit Switched
CSCF	Call Session Control Function (I-Interrogating; P-Proxy and S-Serving)
CSE	CAMEL Service Environment
CTF	Charging Trigger Function
DCCA	Diameter Credit Control Applications
DP	Detection Point
DRP	Data Record Packet
EBCF	Event Based Charging Function
ECUR	Event Charging with Unit Reservation
EDP	Event Detection Point
EIR	Equipment Identity Register
EM	Element Management
EMS-Digits	North American Emergency Service Routing - Digits
EMS-Key	North American Emergency Service Routing - Key
FCI	Furnish Charging Information
FQPC	Fully Qualified Partial CDR
FTAM	File Transfer, Access and Management
GERAN	GSM EDGE Radio Access Network
GGSN	Gateway GPRS Support Node
GMLC	Gateway MLC
GMSC	Gateway MSC
GPRS	General Packet Radio Service
gsmSCF	GSM Service Control Function
gsmSSF	GSM Service Switching Function

GSM	Global System for Mobile communication
GSN	GPRS Support Node (either SGSN or GGSN)
GTP	GPRS Tunnelling Protocol
GTP'	The GPRS protocol used for CDR transport. It is derived from GTP with enhancements to improve transport reliability necessary for CDRs.
G-CDR	GGSN (PDP context) generated - CDR
HLR	Home Location Register
HPLMN	Home PLMN
HSCSD	High Speed Circuit Switched Data
HSS	Home Subscriber Server
H-GMLC	Home - GMLC
IANA	Internet Assigned Numbers Authority
IE	Information Element
IEC	Immediate Event Charging
IHOSS:OSP	Internet Hosted Octet Stream Service: Octet Stream Protocol
IMEI	International Mobile Equipment Identity
IMS	IP Multimedia Subsystem
IMSI	International Mobile Subscriber Identity
IMS-GWF	IMS - GateWay Function
IP	Internet Protocol
IPv4	Internet Protocol version 4
IPv6	Internet Protocol version 6
ISC	IMS Service Control
ISDN	Integrated Services Digital Network
ITU-T	International Telecommunication Union - Telecommunications standardization sector
JIP	Jurisdiction Information Parameter
LAC	Location Area Code
LAN	Local Area Network
LCS	LoCation Service
LR	Location Request
LRN	Location Routing Number
MAP	Mobile Application Part
MBMS	Multimedia Broadcast/Multicast Service
MCC	Mobile Country Code (part of IMSI)
ME	Mobile Equipment
MGCF	Media Gateway Control Function
MGW	Media GateWay
MIME	Multipurpose Internet Mail Extensions
MLC	Mobile Location Center
MMI	Man-Machine Interface
MMS	Multimedia Messaging Service
MMSE	Multimedia Messaging Service Environment
MMSNA	Multimedia Messaging Service Network Architecture
MMSO	Multimedia Messaging Service Originator
MMSR	Multimedia Messaging Service Recipient
MMS R/S	Multimedia Messaging Relay/Server
MNC	Mobile Network Code (part of IMSI)
MO	Mobile Originated
MOC	Mobile Originated Call (attempt)
MO-LR	Mobile Originated Location Request
MRF	Media Resource Function
MRFC	MRF Controller
MRFP	Multimedia Resource Function Processor
MS	Mobile Station
MSC	Mobile Switching Centre
MSCF	Messaging Service Control Function
MSISDN	Mobile Station ISDN number
MSRN	Mobile Station Roaming Number
MT	Mobile Terminated
MTC	Mobile Terminated Call (attempt)
MT-LR	Mobile Terminated - Location Request
M-CDR	Mobility management generated - Charging Data Record

NAR	North America Region
NA-ESRD	North American - Emergency Service Routing Digits
NA-ESRK	North American - Emergency Service Routing Key
NE	Network Element
NI	Network Identifier (part of the APN)
NI-LR	Network Induced - Location Request
NP	Number Portability
NPDB	Number Portability Data Base
OCF	Online Charging Function
OCS	Online Charging System
OI	Operator Identifier (part of the APN)
O-CSI	Originating - CAMEL Subscription Information
PDN	Packet Data Network
PDP	Packet Data Protocol (e.g. IP)
PDU	Packet Data Unit
PLMN	Public Land Mobile Network
PMD	Pseudonym Mediation Device functionality
PoC	Push-to-talk over Cellular
PPP	Point-to-Point Protocol
PPR	Privacy Profile Register
PS	Packet-Switched
PSPDN	Packet-Switched Public Data Network
PSTN	Public Switched Telephony Network
PT	Protocol Type (Field in GTP' header)
QoS	Quality of Service
RAB	Radio Access Bearer
RAC	Routing Area Code
RAN	Radio Access Network
RF	Rating Function
RNC	Radio Network Controller
RNS	Radio Network Subsystem
RPC	Reduced Partial CDR
RTP	Real Time Protocol
R-GMLC	Requesting - GMLC
SAC	Service Area Code
SBCF	Session Based Charging Function
SCCP	Signalling Connection Control Part
SCUR	Session Charging with Unit Reservation
SDP	Session Description Protocol
SCF	Service Control Function
SCI	Subscriber Controlled Input
SCI	Send Charging Information
SGSN	Serving GPRS Support Node
SIM	Subscriber Identity Module
SIP	Session Initiation Protocol
SMS	Short Message Service
SSF	Service Switching Function
SS7	Signalling System No. 7
SCCP	Signalling Connection Control Part
S-CDR	SGSN (PDP context) generated - CDR
S-SMO-CDR	SGSN delivered Short message Mobile Originated - CDR
S-SMT-CDR	SGSN delivered Short message Mobile Terminated - CDR
TAP	Transferred Account Procedure
TBCP	Talk Burst Control Protocol
TDP	Trigger Detection Point
TID	Tunnel Identifier
TLV	Type, Length, Value (GTP header format)
TPF	Traffic Plane Function
TR	Technical Report
TS	Technical Specification
TV	Type, Value
T-CSI	Terminating - CAMEL Subscription Information

UA	User Agent
UE	User Equipment
UMTS	Universal Mobile Telecommunications System
URA	UTRAN Registration Area
USIM	User Service Identity Module
USSD	Unstructured Supplementary Service Data
UTRAN	Universal Terrestrial Radio Access Network
VAS	Value Added Service
VASP	Value Added Service Provider
VLR	Visitor Location Register
VMSC	Visited MSC
VPLMN	Visited PLMN
VT-CSI	Visited Terminating CAMEL Subscription Information
V-GMLC	Visited GMLC
WLAN	Wireless LAN
XDMS	XML Document Management Server
XML	Extensible Mark-up Language

## 4 Architecture considerations

### 4.1 High level PoC architecture

Figure 4.1.1 depicts the PoC reference architecture, as described in TR 23.979 [200].

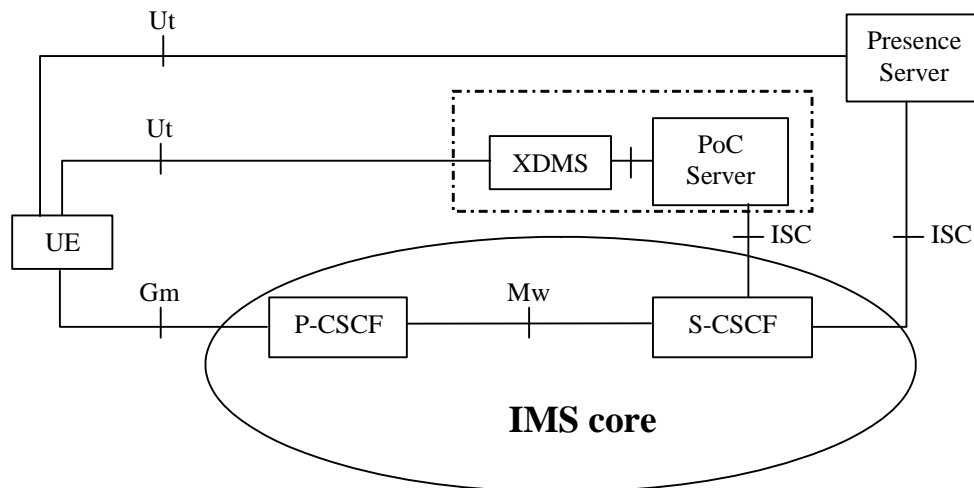

**Figure 4.1.1: PoC service elements in the IMS architecture**

NOTE: The I-CSCF and HSS are not shown in figure 4.1.1 for the sake of simplicity.

The OMA-AD-POC [203] leverages IMS as the underlying SIP-based IP-core network. The PoC Server implementing the application level network functionality for the PoC service is essentially seen as an Application Server (AS) from the IMS perspective. Consequently, communications between the IMS core and the PoC Server utilize the ISC interface defined in TS 23.228 [201].

The XML Document Management Server (XDMS) is used by the PoC users to manage groups and lists (e.g. contact and access lists) that are needed for the PoC service. In the IMS architecture, the Ut interface provides these functions, hence communications between the XDMS and the UE (PoC Client) utilize the Ut interface. The XDMS is seen as a separate AS that could be also connected to other entities in addition to PoC Server (e.g. to Presence Server).

As described in the following clauses only the PoC Server is relevant for charging.

**Editor's note: The figure may be replaced by an OMA version.**

## 4.1.1 PoC functional entities

In the next two subclauses the PoC functional entities, PoC Client and PoC Server are presented as described in OMA-AD-POC [203]. Also different roles of the PoC Server that impact the PoC charging architecture are described.

### 4.1.1.1 PoC Client

The PoC Client resides on the mobile terminal and is used to access PoC service. In figure 4.1.1.2.1, the UE is acting as a PoC Client.

### 4.1.1.2 PoC Server

The PoC Server implements the application level network functionality for the PoC service.

The PoC Server may perform a controlling PoC function or participating PoC function. The controlling PoC function and participating PoC function are different roles of the PoC Server. The figures in this clause show the flow of signalling traffic and media and media-related signalling traffic between controlling PoC function and participating PoC function in various configurations.

Unless otherwise mentioned, the traffic flows shown in each figure apply to both signalling traffic and media and media-related signalling traffic in that configuration.

Figure 4.1.1.2.1 shows the distribution of the functionality during a 1-1 PoC session in a single network.

A PoC Server may perform both a controlling PoC function and a participating PoC function at the same time.

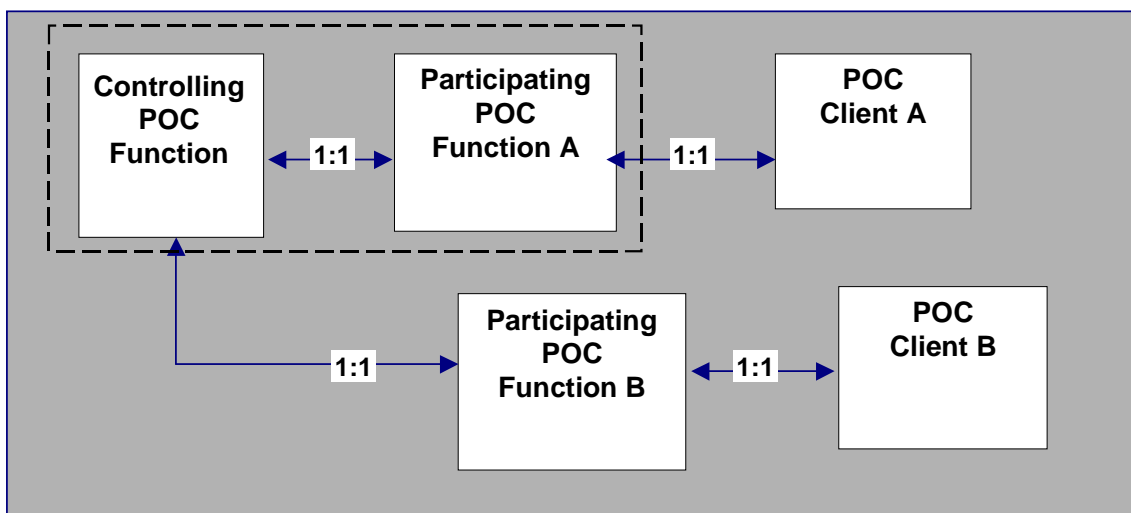
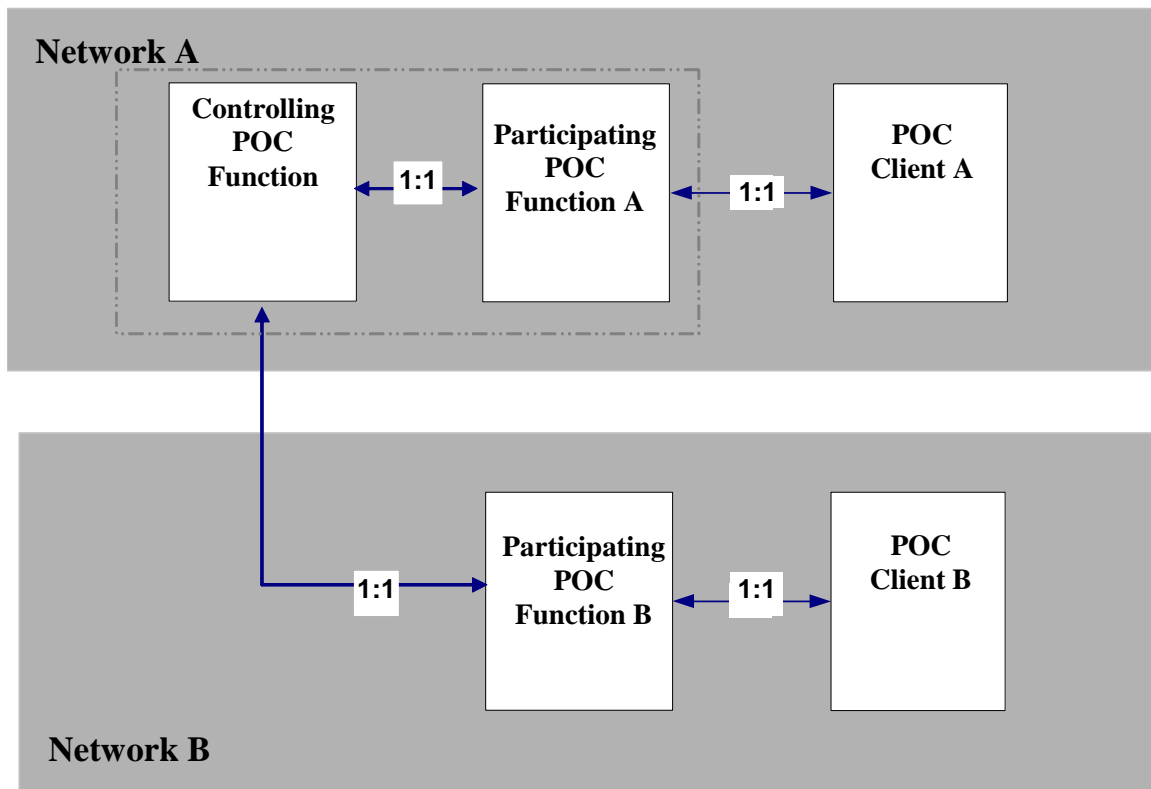

**Figure 4.1.1.2.1: Relationship between controlling PoC function, participating PoC functions and the PoC Clients for 1-1 PoC session in a single network**

The determination of the PoC Server role (controlling PoC function and participating PoC function) takes place during the PoC session set-up and lasts for the duration of the whole PoC session.

In case of 1-1 PoC session and ad-hoc PoC group session the PoC Server of the inviting user shall perform the controlling PoC function. I

n case of the chat PoC group and pre-arranged group session the PoC Server owning/hosting the group identity shall perform the controlling PoC function.



**Figure 4.1.1.2.2: Relationship between the controlling PoC function, participating PoC function and PoC Clients for 1-1 PoC session in a multiple network**

In a PoC session there shall be only one PoC Server performing the controlling PoC function.

There can be one or more PoC Servers performing the participating PoC function in the PoC session.

Figure 4.1.1.2.2 shows the distribution of the functionality during a 1-1 PoC session in a multiple network environment.

The PoC Server performing the controlling PoC function has  $N$  number of SIP sessions and media and talk burst control communication paths in one PoC session, where  $N$  is number of participants in the PoC session.

The PoC Server performing the PoC controlling function has no direct communication to the PoC Client for PoC session signalling, but interacts with the PoC Client via the PoC Server performing the participating functioning for the PoC Client.

The PoC Server performing the controlling PoC function normally also routes the media and media-related signalling such as talk burst arbitration to the PoC Client via the PoC Server performing the participating functioning for the PoC Client. However, local policy in the PoC Server performing the participating PoC function may allow the PoC Server performing the controlling PoC function to have a direct communication path for media and media-related signalling to each PoC Client.

Figure 4.1.1.2.3 shows the signalling and media paths in this configuration for a controlling PoC function, participating PoC function and PoC Client served in the same network.

A PoC Server performing the participating PoC function has always a direct communication path with a PoC Client and a direct communication path with the PoC Server performing the controlling PoC function for PoC session signalling.

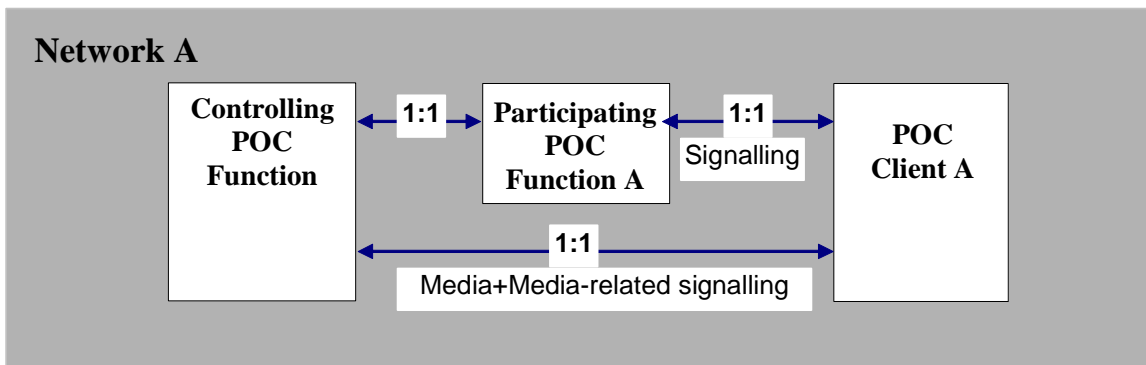

Figure 4.1.1.2.3: Direct media flow between controlling PoC function and PoC Client

Figure 4.1.1.2.4 depicts the relation between the controlling PoC function, participating PoC function and the PoC Client in multiple network environment for a PoC group session.

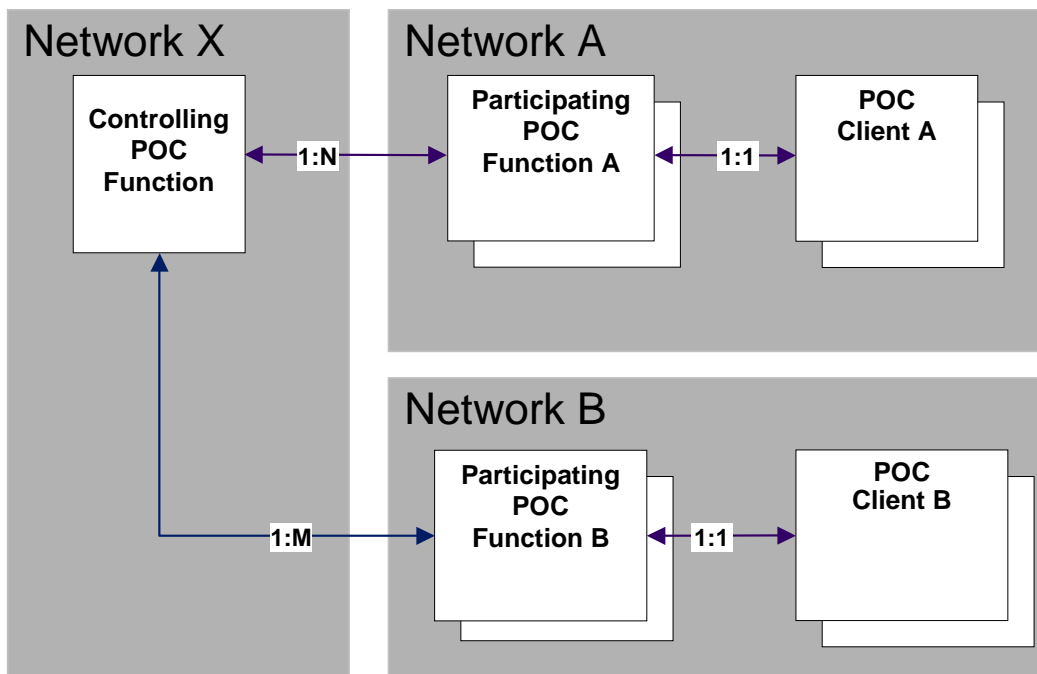
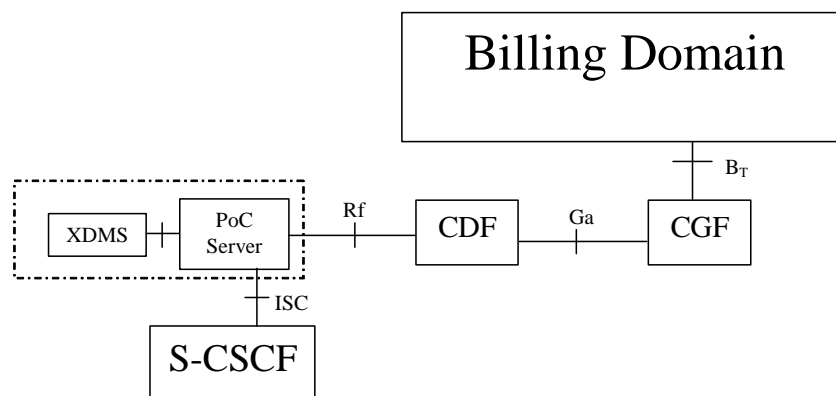

Figure 4.1.1.2.4: Relationship between the controlling PoC function, participating PoC function and PoC Clients for PoC group session



## 4.2 PoC offline charging architecture

Figure 4.2 depicts the PoC offline charging architecture, as described in TR 23.979 [200].

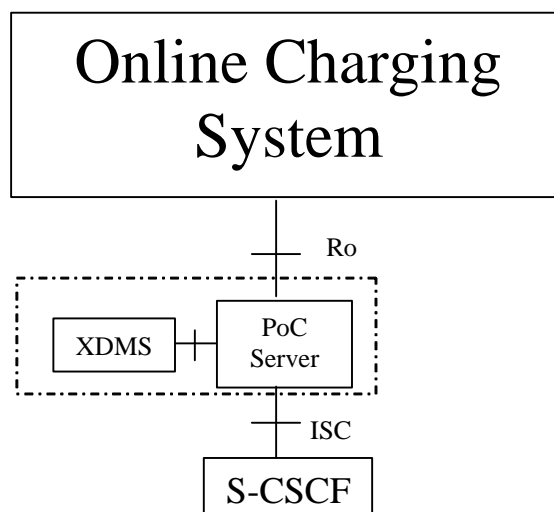

**Figure 4.2: Charging architecture for PoC offline charging**

As described in TS 32.240 [1], the PoC Server contains an integrated CTF that generates charging events and forwards them to the CDF. The CDF, in turn, generates CDRs which are then transferred to the CGF. Finally, the CGF creates CDR files and forwards them to the Billing Domain (BD). The possible mapping onto physical components and interfaces for the charging functions is described in TS 32.240 [1].

## 4.3 PoC online charging architecture

Figure 4.3 depicts the PoC online charging architecture, as described in TR 23.979 [200].



**Figure 4.3: Charging architecture for PoC online charging**

When PoC Server fulfils the controlling PoC function, then it provides centralized charging reports. When it fulfils the participant PoC function, then it provides the participant charging reports. For online charging, the PoC Server uses the  $R_o$  interface and application towards the OCS as specified in TS 32.299 [50].

The OCS considers and treats controlling PoC Server online charging reports and participant PoC Server online charging reports as independent reports (independent events if IEC is used or independent sessions if charging is SCUR based).

---

## 5 PoC charging principles and scenarios

### 5.0 General

PoC charging architecture support service based charging. If there is a support required for traffic based charging than the FBC should be used refer TS 32.251 [11].

**Editor's note: The investigation on subscription based charging is needed.**

### 5.1 PoC charging principles

#### 5.1.1 PoC session related charging

PoC allows users to satisfy real time, half-duplex speech communication in a simple and easy way. A PoC subscriber may either join an existing PoC session or may create a PoC session spontaneously. A PoC participant, who wants to speak, typically initiates a PoC session on its terminal and starts to speak. Other participants of the PoC group session simultaneously listen to the speaker's voice.

The charged parties may be any of the PoC participants, depending on the role he is taking. These roles are:

- PoC session owner;
- PoC participant.

The charging of the PoC session owner is measured by the controlling PoC function. Note that PoC session owner does not have to participate in a specific PoC session (e.g. pre-arranged PoC group session). It provides centralized charging reports. In the PoC architecture the participating PoC function measures and sends charging reports to the charging system for the charging of the participant.

Charging should be done according the following types of PoC sessions according OMA-AD-POC [203]:

- 1-1 PoC session;
- PoC group session:
  - ad-hoc PoC group session;
  - pre-arranged PoC group session;
  - chat PoC group session.

**Editor's note: The use of PoC communication methods (single participant in a 1-1 PoC session, PoC group in a 1-many session or in a 1-many-1 session.) is FFS.**

There are two mechanisms for PoC session establishment signalling supporting as described in OMA-AD-POC [203]:

- on-demand sessions,
- pre-established sessions.

An 1-1 PoC session along with PoC group session can be established on-demand or within a pre-established session. Charging should distinguish both scenarios.

PoC user can participate in PoC session in three types according to OMA-AD-POC [203]:

- Normal;
- NW PoC Box;
- UE PoC Box.

Charging should distinguish the three scenarios above for support of traffic based charging.

The charging of the PoC participant and/or PoC session owner can be done:

- **for the following services:**

1. PoC session participation (per time period independent of usage).
2. Talk burst sending: Amount of talk bursts sent by the participant. Amount of talk bursts shall be measured as a number of talk bursts and/or as a duration and/or volume of talk bursts.

When talk burst sending is charged as a number of talk bursts, only the TBCP talk burst granted message (in response to TBCP talk burst request message) received in PoC Client should be taken into account. Note that TBCP talk burst granted message could be lost. In this case, timer T11 expires in PoC Client and it sends a TBCP talk burst request message again OMA-UP-POC: "OMA POC User Plane" [205]. Therefore, several TBCP talk burst granted message could be unsuccessfully sent and they should not be charged. To fulfil this aim, PoC Server shall meter one talk burst:

- when it receives the first RTP media packet for this talk burst, or
  - when it receives the TBCP talk burst release message, independently if the PoC Client sent RTP media toward the PoC Server when PoC Client had the floor.
3. Talk burst receiving: Amount of talk bursts received by the participant. Amount of talk bursts shall be measured as a number of talk bursts and/or as a duration and/or volume of talk bursts.

**Editor's note: Sent/Received talk burst may be independent of the talk burst control protocol messages, means the successful or unsuccessful delivery.**

**Editor's note: The interruption of the PoC session with "media put on hold/off hold" is FFS.**

- **for the following rating parameters:**

1. PoC session type as defined above;
2. number, type or list(s) of participants/talk burst receivers (see clause 5.1.3);
3. identity of the serving network (e.g. SGSN PLMN identifier for the charged party);
4. date and time of PoC service usage.

Session related PoC charging is SCUR based. Hence, number of "Right-to-Speak" and talk burst exchange shall be charged by SCUR and the metering will be performed in the PoC Server. This is an important efficiency improvement since event based talk burst charging would imply the need to generate events or CDRs for each talk burst potentially for each charged party.

The PoC Server decides whether the session owner and/or the participants are to be charged for the services, e.g. session owner is charged for session participation and each participant is charged for talk burst exchange. This decision is based on configuration in the offline case and is governed by the OCS in the online case. Units for service usage are reported independently, e.g. separate minutes for session participation and number of sent and received talk bursts.

Details how this is supported are specific to online and offline charging and will be given in the subsequent clauses.

### 5.1.2 PoC session unrelated charging

To reflect chargeable events not directly related to a PoC session, offline and online charging procedures have to consider the occurrence of the following session unrelated SIP procedures:

- Sending/Receiving instant personal alert. Unsuccessful message shall not be charged.
- Sending/Receiving PoC group advertisement. Unsuccessful message shall not be charged.
- PoC Client subscription to the conference state (based on a PoC group identity of the PoC group or on a PoC session identity).
- PoC Client adding a user to a PoC session.
- PoC Client adding/removing media type to/from a PoC session.
- PoC Client handling for PoC session locking in a particular PoC session (simultaneous session control): the PoC Client may request to lock itself in a particular PoC session while initiating a PoC session or at any time later when a valid PoC session exists.
- Early session setting-up.
- PoC Client handling for PoC session priority in a particular PoC session (simultaneous session control): the PoC Client may set a PoC session priority in a particular PoC session while initiating a PoC session or at any time later when a valid PoC session exists.

### 5.1.3 Charging based on number of participants

Charging based on number of participants is possible at both the controlling and participating PoC Servers if the information is provided by the controlling PoC Server to the participating PoC Server as defined by OMA PoC User Plane [205].

## 5.2 PoC offline charging scenarios

### 5.2.0 General

Editor's note: < If the present document does not specify offline charging for XXX, then an appropriate reference or other explanation shall be provided (cf. scope clause), and all following subclauses shall only have the text "Void. Refer to clause 5.2". >

#### 5.2.1 Basic principles

The charging models as given in clause 5.1 are supported for offline charging. CDRs are generated for the charged parties that are configured in the PoC Server.

These CDRs contain distinguished service usage data for any of the described sub-services. They may contain only usage data related to one subscriber or may aggregate service usage. The latter case occurs e.g. in the charging model where the session owner is charged for all session participants. Accumulated or detailed talk burst usage data given in the CDRs will hold duration, volume and number of talk bursts. It is up to the Billing Domain (BD) to rate them according to selected rate plans.

Event CDRs are generated for the early session establishment and instant personal alerts delivery.

Interim and final CDRs are generated for PoC session participation and talk burst usage. The generation of interim CDRs will be governed by configurable timers at the PoC Server, changes to the session, and any changes in location of the user made known to the PoC Server.

#### 5.2.2 Message flows

The flows described in the present document specify the charging communications between PoC Server and the charging functions for different charging scenarios. The SIP messages associated with these charging scenarios are shown primarily for general information and to illustrate the charging triggers. They are not intended to be exhaustive of all the SIP message flows discussed in TS 24.228 [202].

##### 5.2.2.1 Message flows - Successful cases and scenarios

###### 5.2.2.1.1 Successful PoC session establishment

Figure 5.2.2.1.1 shows the Charging Data transactions that are required between PoC Server and CDF during PoC session establishment originated by a PoC Client. The Charging Data Request triggers the first CPF-CDR sequence in

the controlling PoC Server and the first PPF-CDR sequence is generated for each participant in the participating PoC Server. More CPF-CDR sequences possible for additional participants.

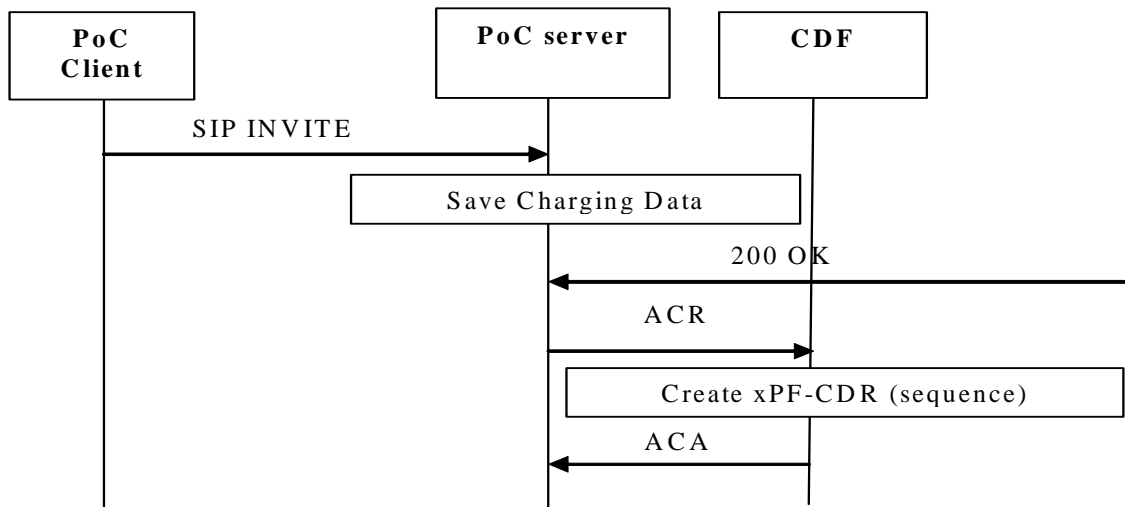

Figure 5.2.2.1.1: Message sequence chart for offline charging PoC session establishment

5.2.2.1.2 PoC talk burst exchange

Figure 5.2.2.1.2 shows the Charging Data transactions that are required between PoC Server and CDF during talk burst exchange.

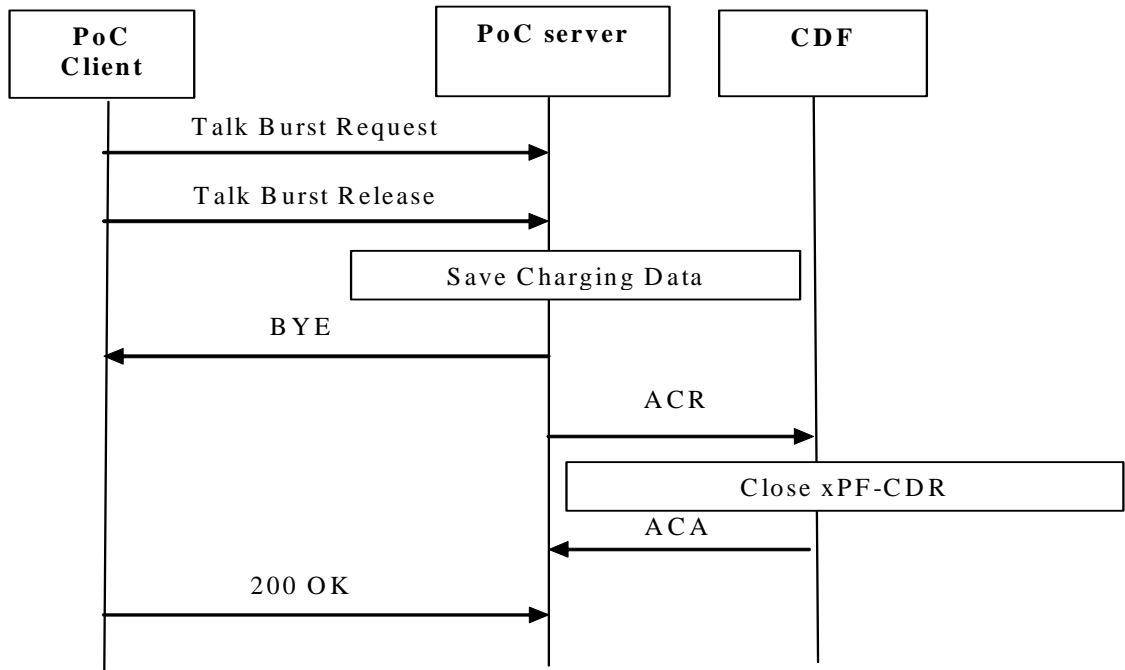

Figure 5.2.2.1.2: Message sequence chart for offline charging PoC talk burst exchange

5.2.2.1.3 Instant personal alert

Figure 5.2.2.1.3 shows the Charging Data transactions that are required between participating PoC Server and CDF for the "Instant Personal Alert" delivery.

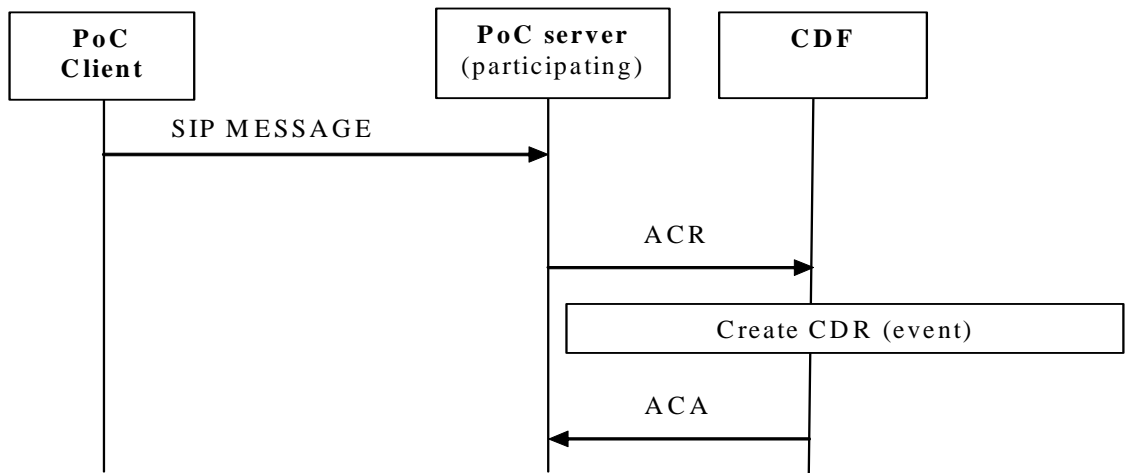

Figure 5.2.2.1.3: Message sequence chart for offline charging Instant personal alert

5.2.2.1.4 Pre-established session set-up

Figure 5.2.2.1.4 shows the Charging Data transactions that are required between participating PoC Server and CDF for the pre-established session with the early session indication.

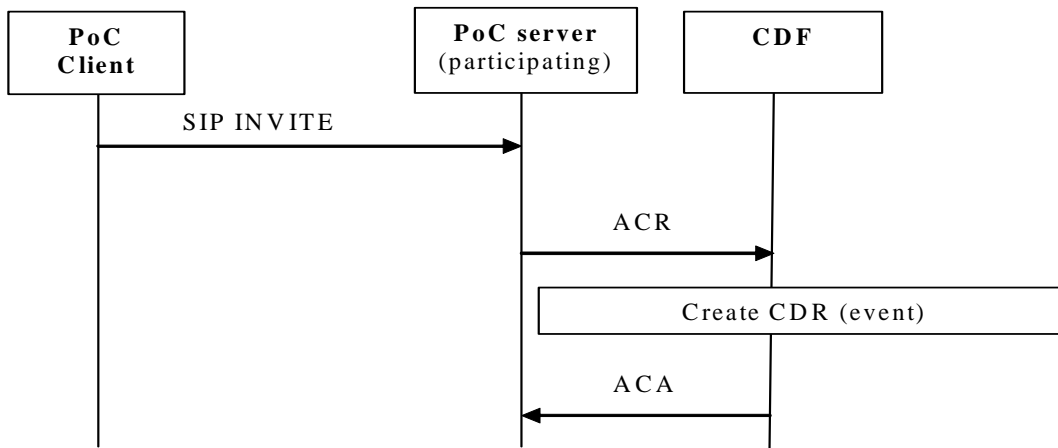

Figure 5.2.2.1.4: Message sequence chart for offline charging pre-established session set-up

5.2.2.1.5 Mid PoC session procedures

Figure 5.2.2.1.5 shows the Charging Data transactions that are required between PoC Server and CDF in the Mid-PoC session when SIP INVITE or SIP BYE request are received at the PoC Server. The Charging Data Request [ Start] triggers the first CPF-CDR sequence in the Controlling PoC Server and the first PPF-CDR sequence is generated for each participant in the Participating PoC Server. When SIP INVITE or SIP BYE request are sent to controlling server, Controlling PoC Server performs service control function, to recognize if the request is a chargeable event. If so, the Controlling PoC Server sends Charging Data Request[Interim].

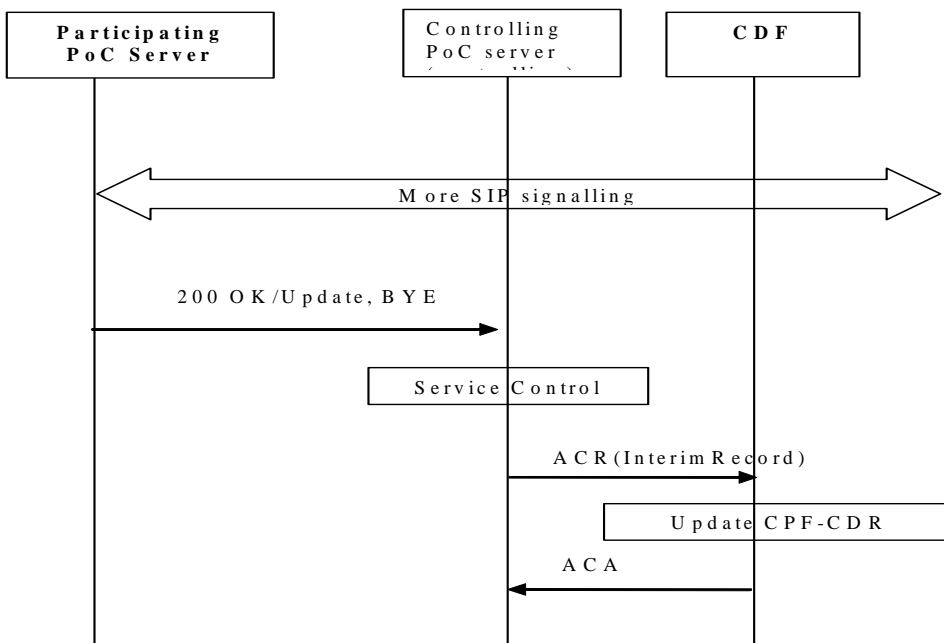

Figure 5.2.2.1.5: Message sequence chart for offline charging in Mid PoC session



### 5.2.3 CDR generation

The controlling PoC function CDR (CPF-CDR) and participating PoC function CDR (PPF-CDR) are generated by the PoC Server to collect charging information that they subsequently transfer to the Charging Gateway Function (CGF).

### 5.2.4 GTP' record transfer flows

The principles and protocol applications specified in TS 32.295 [54].

### 5.2.5 B<sub>T</sub> CDR file transfer

The CDR file transfer for PoC charging is supported on the B<sub>T</sub> interface, as specified in TS 32.240 [1]. For further details on the B<sub>T</sub> protocol application refer to TS 32.297 [52].

## 5.3 PoC online charging scenarios

### 5.3.1 Basic principles

PoC online charging is done according to the general principles of Debit / Reserve Units operation as specified in TS 32.299 [50]. The PoC Server generates online charging messages that contain distinguishable service usage data for any of the sub-services.

PoC online charging utilizes one time event charging for early (pre-established) sessions (session set-up is charged only) and instant personal alerts and session charging for PoC session and PoC talk burst exchange. Thus the PoC online charging interface will address both the Session Based Charging Function (SBCF) and the Event Based Charging Function (EBCF) with the OCS. There is a general PoC service with four sub-services in the interface. Each of the sub-services has specific charging information and behaviour. The DCCA concept of multiple service credit control are supported. As described by DCCA, unused reserved units for PoC session participation are released on session termination.

Talk burst exchange is a session based service with SCUR which may be metered by duration, volume or number. The metering is done on the PoC Server and governed in a DCCA conformal way by the OCS.

Upon charging request it returns granted units of either of the three types. Unused reserved units for talk burst exchange are released at PoC session termination or based on an inactivity timer. For number of talk burst level reporting, the service specific unit shall be used to represent individual talk bursts. For talk burst duration reporting, the time based unit shall be used. For talk burst volume reporting, the volume unit shall be used.

For an "Instant Personal Alert", which is an event unrelated to a PoC session, the PoC online charging utilizes event charging for the message including a unit reservation i.e. ECUR.

### 5.3.2 Diameter message flows

#### 5.3.2.1 Successful PoC session establishment

Figure 5.3.2.1 shows the Debit / Reserve Units operation that are required between PoC Server and OCS during PoC session establishment originated by a PoC Client.

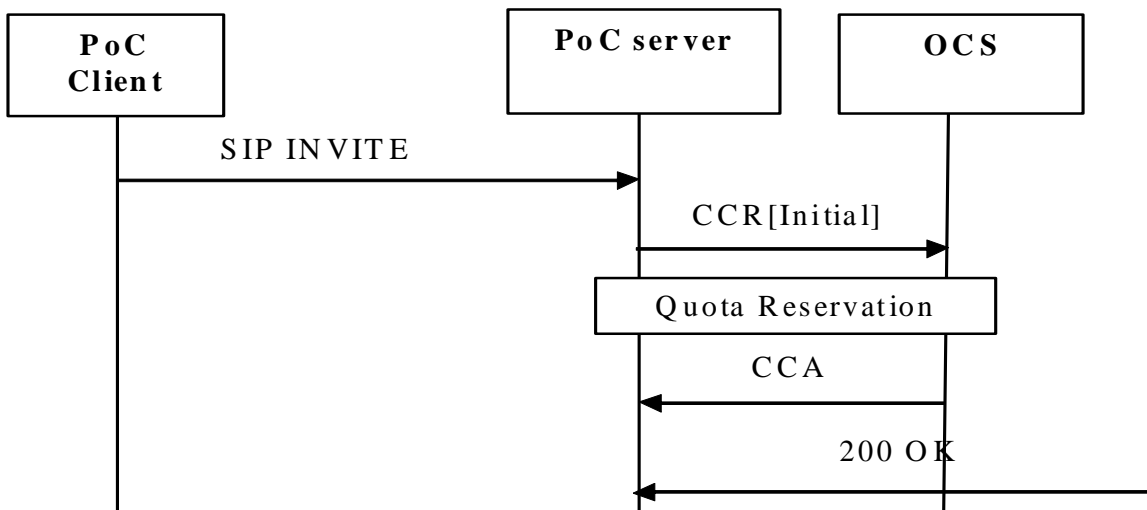
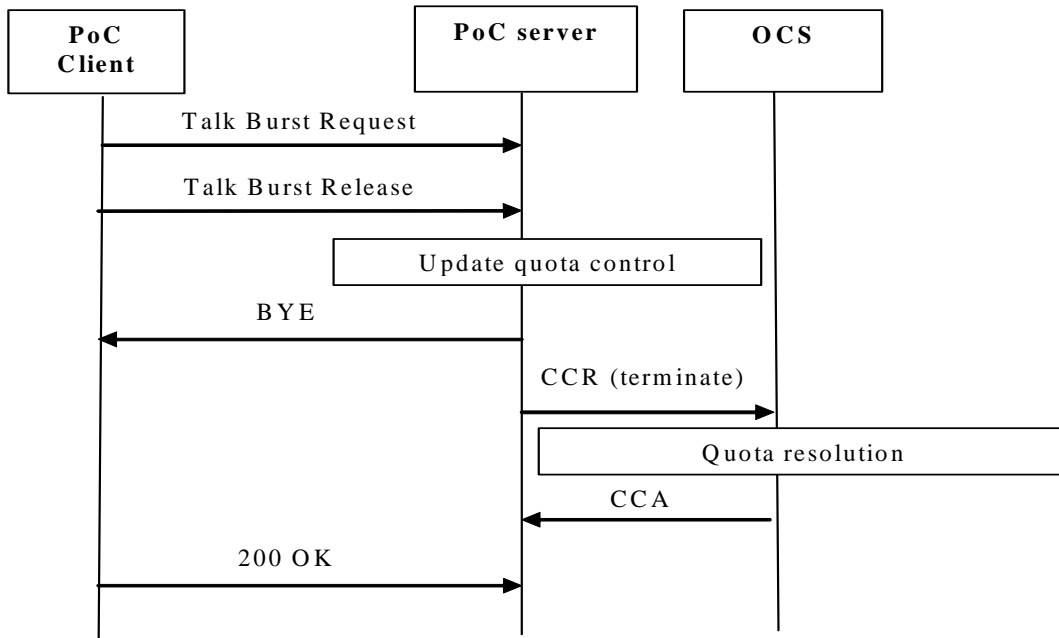

Figure 5.3.2.1: Message sequence chart for online charging PoC session establishment

Editor's Note: Detailed message description including the handling of RSU, GSU and USU should be added.

### 5.3.2.2 PoC talk burst exchange

Figure 5.3.2.2 shows the Debit / Reserve Units operation that are required between PoC Server and OCS during talk burst exchange.



**Figure 5.3.2.2: Message sequence chart for online charging PoC talk burst exchange**

### 5.3.2.3 Instant personal alert

Figure 5.3.2.3 shows the Debit / Reserve Units operation that are required between participating PoC Server and OCS for the (successful) "Instant Personal Alert" delivery. Each "Instant Personal Alert" shall be treated independently

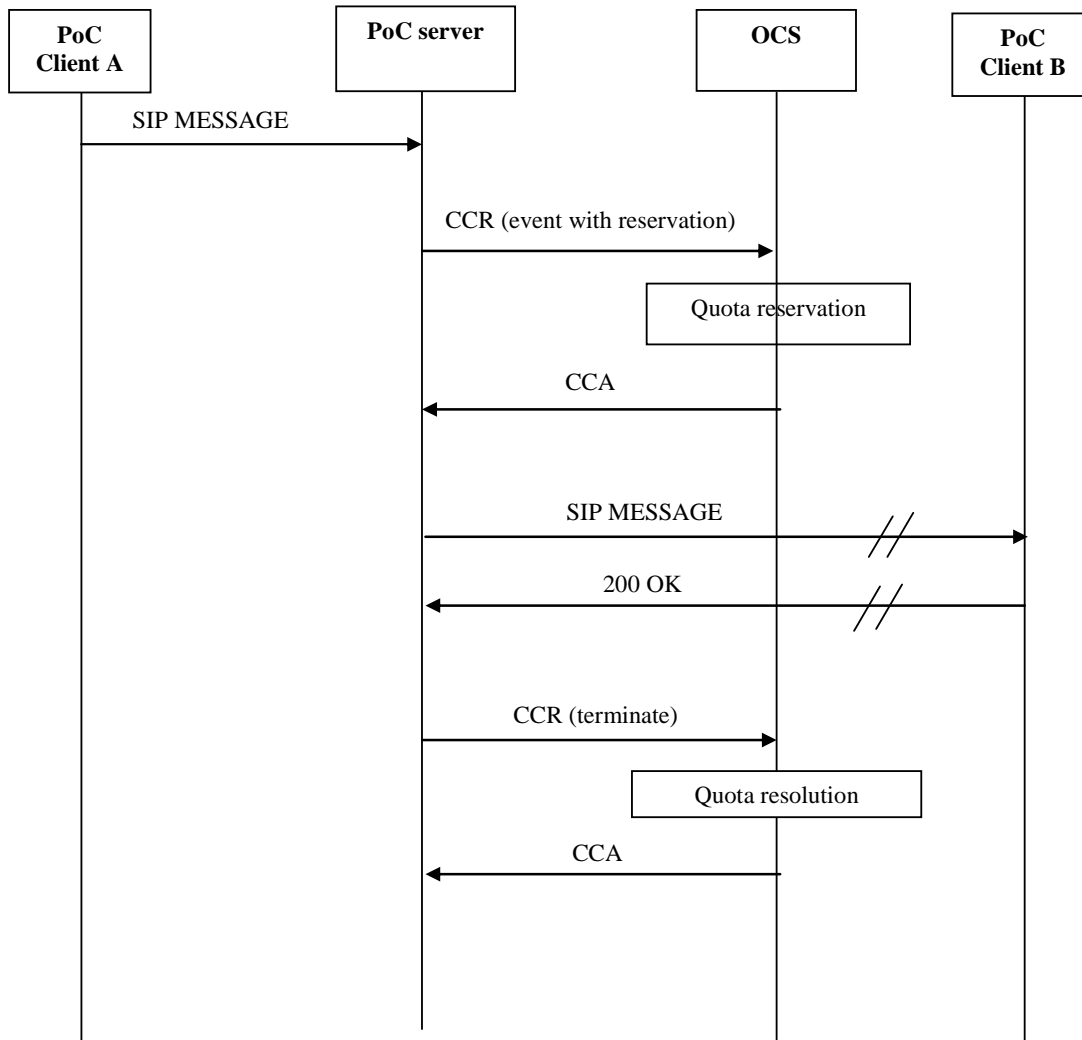

**Figure 5.3.2.3: Message sequence chart for online charging Instant personal alert**

NOTE: The SIP 200 OK response to the PoC Client A has been omitted from figure 5.3.2.3 but can occur at any point after the SIP 200 OK is received from PoC Client B.

For successful message delivery, the Debit Units Request[ Terminate] shall report the used quota.

For unsuccessful message delivery, determined by a response timeout or a SIP error response e.g. 4xx, the PoC Server return the quota as unused within the Debit Units Request[ Terminate].

### 5.3.2.4 Early session set-up

Early session set-up is a preparation process for later PoC session establishment. The required negotiations, media negotiation, bearing parameters negotiation, etc, among different PoC users are also different, which occupy different resources that PoC Server can not predict before. ECUR is referred here.

Figure 5.3.2.4 shows the charging flow between PoC Server (participating) and OCS for pre-established session (early session):

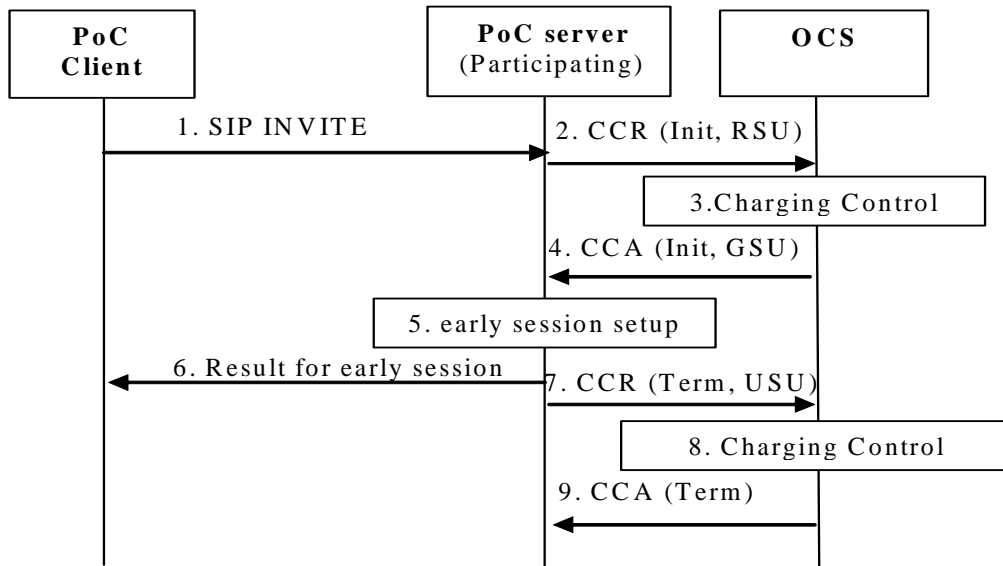
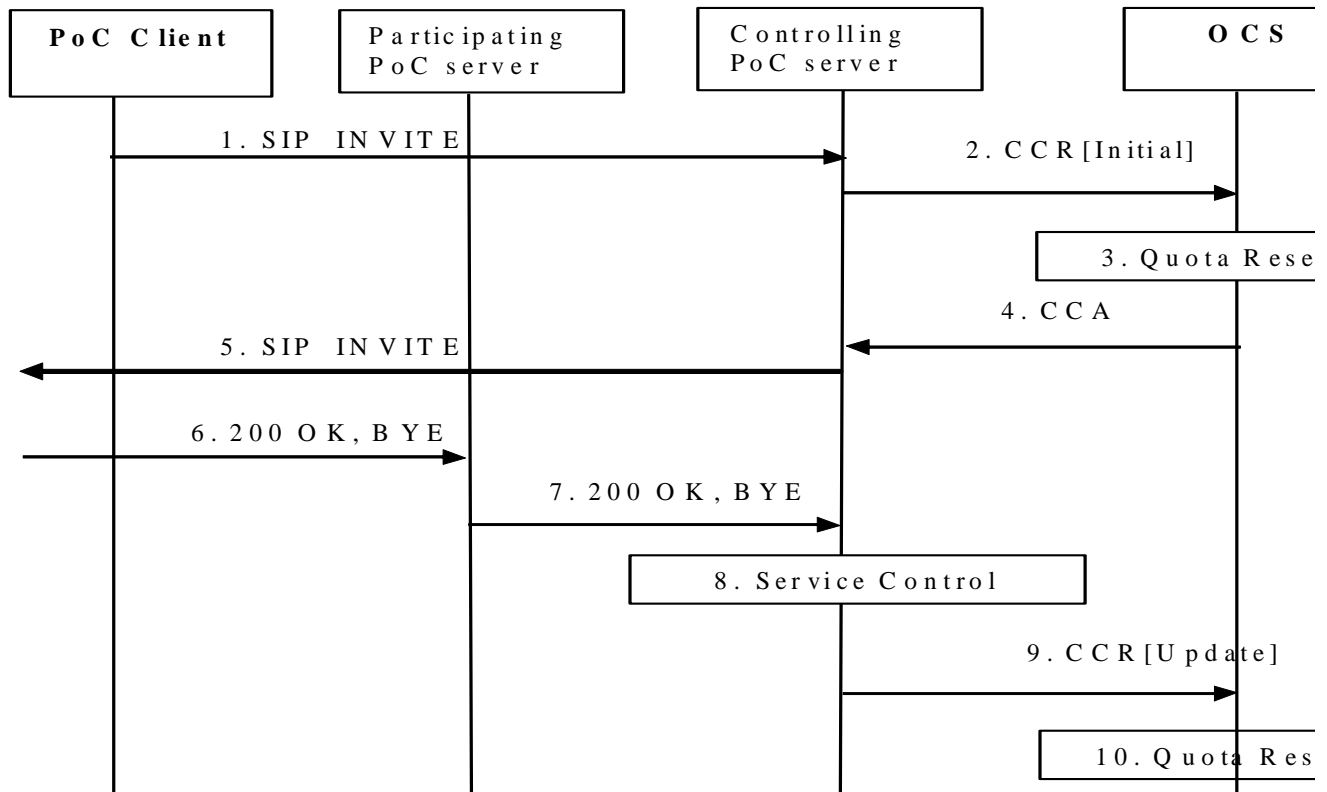

**Figure 5.3.2.4: Message sequence chart for Pre-established session Set-up online charging**

1. PoC Client sends SIP INVITE request to PoC Server (participating) for early session setup.
2. After receiving the request PoC Server sends Reserve Units Request[Initial] to OCS for reservation by RSU(Requested-Service-Unit).
3. The OCS performs unit reservation.
4. The OCS sends back the response to PoC Server (participating) to authorize the service request with GSU(Granted-Service-Unit)
5. PoC Server (participating) starts to initiate the early session for PoC Client.
6. When finishing early session setup PoC Server responses back the result to PoC Client.
7. Also PoC Server (participating) sends Debit Units Request[Terminate] to OCS by USU(Used-Service-Unit) to indicate resource usage and result of early session setup.
8. OCS performs debit.
9. OCS sends back CCA to PoC Server (participating) to indicate charging control result.

### 5.3.2.5 Participant number based charging

Figure 5.3.2.5 shows the Debit / Reserve Units operation that are required between Controlling PoC Server and OCS in participant number based charging for the session owner.

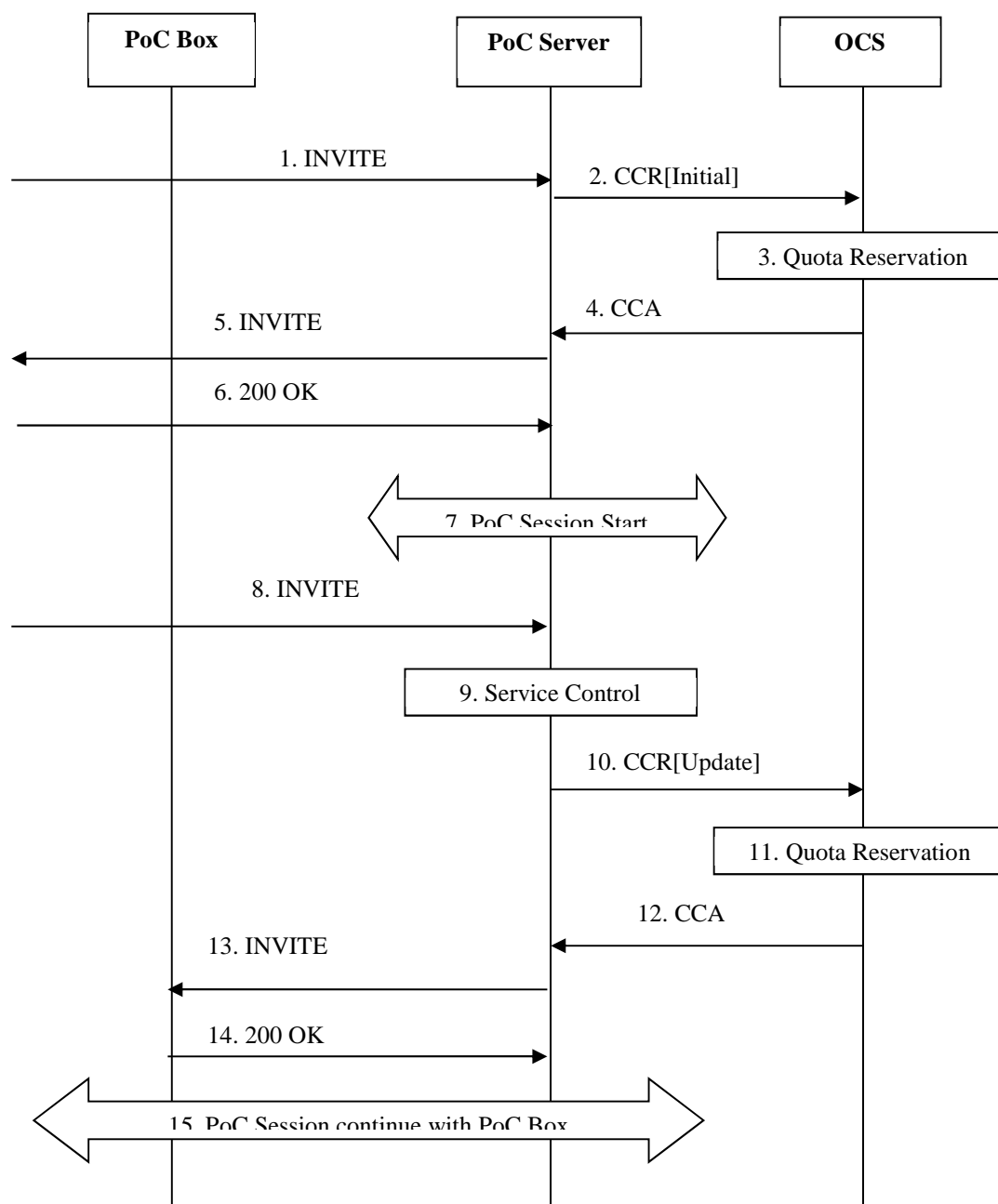

**Figure 5.3.2.5: Message sequence chart for offline charging in Mid PoC session**

1. PoC Client sends SIP INVITE request to controlling PoC Server to generate a multi-participants session.
2. Controlling PoC Server sends Reserve Units Request[Initial] to OCS, with the pre-defined group participant number for quota reservation. In case of the Ad-hoc session, Controlling PoC Server sends Reserve Units Request[Initial] for quota reservation, with initial invited participant number.
3. OCS performs Quota reservation.
4. OCS responses the CCA with enabling trigger condition of CHANGE\_IN\_PARTICIPANTS\_NMB or CHANGE\_IN\_THRSHLD\_OF\_PARTICIPANTS\_NMB.
5. Controlling PoC Server forward the SIP INVITE request to participants.
6. During the session ongoing, participant can send SIP BYE or SIP 200 OK to Participating PoC Server.
7. Participating PoC Server forwards the message to Controlling PoC Server.
8. Controlling PoC Server monitors the trigger conditions, if one of the conditions occurs, it goes to next procedure.
9. Controlling PoC Server sends update request, with the changed Rating Group.
10. OCS performs re-authorization.
11. OCS sends CCA to Controlling PoC Server.

### 5.3.2.6 Participating type based charging

Figure 5.3.2.6 shows the Debit / Reserve Units operation that are required between Controlling PoC Server and OCS in participant type based charging for the session owner and participants.



**Figure 5.3.2.6: Message sequence chart for online charging Participating type**

1. PoC Server receives SIP INVITE.
2. PoC Server sends Reserve Units Request[Initial] to OCS.
3. OCS performs Quota reservation.
4. OCS responses the CCA with enabling trigger condition of CHANGE\_IN\_USER\_PARTICIPATING\_TYPE.
5. PoC Server forwards the SIP INVITE request to participants.
6. PoC Server receives the SIP 200 OK for SIP INVITE.

7. PoC session start.
8. During the session ongoing, participant can send SIP INVITE to PoC Server to invite PoC Box.
9. Controlling PoC Server monitors the trigger conditions, if one of the conditions occurs, it goes to next procedure.
10. PoC Server sends Reserve Units Request [Update] request, with the changed Rating Group.
11. OCS performs re-authorization.
12. OCS sends CCA to PoC Server.
13. PoC Server forwards SIP INVITE to PoC Box.
14. PoC Box response to PoC Server with SIP 200 OK.
15. PoC session continues.



## 6 Definition of charging information

### 6.1 Data description for PoC offline charging

#### 6.1.0 General

The PoC Server generates charging information that can be transferred from the CTF to the CDF with the Charging Data transfer operation. Detailed information about the usage of the Charging Data transfer operation is described in TS 32.299 [50].

#### 6.1.1 Rf message contents

##### 6.1.1.1 Summary of offline charging message formats

The PoC Charging application for offline charging employs the Charging Data Request and Charging Data Response. The Charging Data Request can be of type start, stop, interim and event and includes all charging information. The Charging Data Response is just an acknowledgement of the CHARGING DATA REQUEST.

Table 6.1.1.1 describes the use of these messages for offline charging.

**Table 6.1.1.1: Offline charging messages reference table**

Message	Source	Destination
Charging Data Request	PoC Server	CDF
Charging Data Response	CDF	PoC Server

##### 6.1.1.2 Structure for the Charging Data message formats

###### 6.1.1.2.0 Introduction

PoC offline charging used the Charging Data transfer with the two messages Charging Data Request and Charging Data Response. The request can be of type Start, Stop, Interim and Event. The Charging Data Request message includes all charging information and the answer is just an acknowledgement of the request message. Detailed information about the offline charging application is described in TS 32.299 [50].

This clause describes the different fields used in the Charging Data messages. and the category in the tables are used according to the charging data configuration defined in clause 5.4 of TS 32.240 [1]

### 6.1.1.2.1 Charging Data Request message

Table 6.1.1.2.1.1 illustrates the basic structure of a Charging Data Request message as used for PoC offline charging.

**Table 6.1.1.2.1.1: Charging Data Request message contents for offline charging**

Information Element	Category	Description
Session Identifier	M	Used as described in TS 32.299 [50].
Originator Host	M	Used as described in TS 32.299 [50].
Originator Domain	M	Used as described in TS 32.299 [50].
Destination Domain	M	Used as described in TS 32.299 [50].
Operation Type	M	Used as described in TS 32.299 [50].
Operation Number	M	Used as described in TS 32.299 [50].
Operation Identifier	O <sub>M</sub>	Used as described in TS 32.299 [50].
	O <sub>C</sub>	Used as described in TS 32.299 [50].
User Name	O <sub>C</sub>	Used as described in TS 32.299 [50].
Destination Host	O <sub>C</sub>	Used as described in TS 32.299 [50].
Operation Interval	O <sub>C</sub>	
Origination State	O <sub>C</sub>	
Origination Timestamp	O <sub>C</sub>	
Proxy Information	-	Not used in 3GPP.
Route Information	-	Not used in 3GPP.
Operation Token	O <sub>M</sub>	Used as described in TS 32.299 [50]
Service Information	O <sub>M</sub>	This field holds the PoC specific parameter and is described in clause 6.3. Subscription-Id is used as described in TS 32.299 [50]

NOTE: Detailed descriptions of the fields are provided in TS 32.299 [50].

### 6.1.1.2.2 Charging Data Response message

Table 6.1.1.2.2.1 illustrates the basic structure of a Charging Data Response message as used for PoC charging. This message is always used by the CDF as specified below, regardless of the PoC Server it is received from and the Charging Data Request record type that is being replied to.

**Table 6.1.1.2.2.1: Charging Data Response message contents for offline charging**

Information Element	Category	Description
Session Identifier	M	Used as described in TS 32.299 [50].
Operation Result	M	Used as described in TS 32.299 [50].
Originator Host	M	Used as described in TS 32.299 [50].
Originator Domain	M	Used as described in TS 32.299 [50].
Operation Type	M	Used as described in TS 32.299 [50].
Operation Number	M	Used as described in TS 32.299 [50].
Operation Identifier	O <sub>C</sub>	Used as described in TS 32.299 [50].
Error Reporting Host	-	Not used in 3GPP.
Operation Interval	O <sub>C</sub>	Used as described in TS 32.299 [50].
Origination State	O <sub>C</sub>	Used as described in TS 32.299 [50].
Origination Timestamp	O <sub>C</sub>	Used as described in TS 32.299 [50].

## 6.1.2 GTP' message contents

Editor's note:

< Based on clause 5.2.4. If not applicable as per 5.2.4, insert only the following text. >

{Not applicable. Refer to clause 5.2.4 for further information.}

## 6.1.3 CDR description on the B<sub>T</sub> interface

### 6.1.3.1 CDR field types

The content of the PoC CDR type is defined in table 6.1.3.3.1 and table 6.1.3.3.2. For the CDR type the field definition includes the field name, category and description. The category in the tables are used according to the charging data configuration defined in clause 5.4 of TS 32.240 [1]. The detailed field descriptions are provided in TS 32.298 [51].

The CDF provides the CDRs at the B<sub>T</sub> interface in the format and encoding described in TS 32.298 [51]. Additional CDR formats and contents may be available at the interface to the billing system to meet the requirements of the billing system, these are outside of the scope of 3GPP standardization.

### 6.1.3.2 CDR triggers

#### 6.1.3.2.1 PoC session related CDRs

Reflecting the usage of PoC sessions CDRs are generated by the CDF on a per session basis. In the scope of the present document the term "PoC session" refers to the following cases:

- 1 to 1 PoC sessions;
- PoC group sessions (1 to many).

Accounting information for SIP sessions is transferred from the PoC Server to the CDF using Charging Data Request [Start, Interim and Stop] messages. A PoC session CDR is opened in the CDF upon reception of a Diameter Charging Data Request [Start] message.

Partial CDRs may be generated upon reception of a Charging Data Request [Interim] message.

The Diameter Charging Data Request [Interim] message is sent by the network entity towards the CDF due to a session modification procedure (i.e. change in media) , due to a change to location of the user, or due to usage threshold (e.g. volume, duration, number of change conditions).

Session CDRs are updated, or partial CDRs are generated upon reception of a Charging Data Request [Interim] message, which is sent by the network entity due to expiration of the Accounting-Interim-Interval parameter.

The CDF closes the final session CDR upon reception of a Charging Data Request [Stop] message, which indicates that the SIP session is terminated.

Accounting information for unsuccessful session set-up attempts may be sent by the PoC Server to the CDF employing the Charging Data Request [Event] message. The behaviour of the CDF upon receiving Charging Data Request [Event] messages is specified in clause 6.1.3.2.2.

#### 6.1.3.2.2 Session unrelated CDRs

To reflect chargeable events not directly related to a PoC session the CDF may generate CDRs upon the occurrence of session unrelated SIP procedures, such as:

- Sending/Receiving instant personal alert. Unsuccessful message shall not be charged.
- Sending/Receiving PoC group advertisement. Unsuccessful message shall not be charged.
- PoC Client subscription to the conference state (based on a PoC group identity of the PoC group or on a PoC session identity).
- PoC Client adding a user to a PoC session
- PoC Client handling for PoC session locking in a particular PoC session (simultaneous session control): the PoC Client may request to lock itself in a particular PoC session while initiating a PoC session or at any time later when a valid PoC session exists.
- PoC Client handling for PoC session priority in a particular PoC session (simultaneous session control): the PoC Client may set a PoC session priority in a particular PoC session while initiating a PoC session or at any time later when a valid PoC session exists.

Accounting information for SIP session-unrelated procedures is transferred from the PoC Server to the CDF using Diameter Charging Data Request [Event] messages. Session unrelated CDRs are created in the CDF in a "one-off"

action based on the information contained in the Diameter Charging Data Request [Event] message. One session unrelated CDR is created in the CDF for each Diameter Charging Data Request [Event] message received, whereas the creation of partial CDRs is not applicable for session unrelated CDRs.

### 6.1.3.3 PoC CDR content

The detailed description of the field is provided in TS 32.298 [51].

#### 6.1.3.3.1 Participating PoC Function

Table 6.1.3.3.1.1 contains the content of Participating PoC Function (PPF) CDR.

**Table 6.1.3.3.1.1: Charging data of PPF-CDR**

Field	Category	Description
Record Type	M	Identifies the PoC service record.
Retransmission	O <sub>C</sub>	This parameter, when present, indicates that information from retransmitted Diameter Charging Data Requests has been used in this CDR.
SIP Method	O <sub>C</sub>	Specifies the SIP-method for which the CDR is generated. Only available in session unrelated cases. This parameter corresponds to Event-Type.
Node Address	O <sub>M</sub>	This item holds the address of the node providing the information for the CDR. This may either be the IP address or the FQDN of the IMS node generating the accounting data. This parameter corresponds to the <i>Origin-Host</i> .
Session ID	O <sub>M</sub>	The Session identification. For a SIP session the Session-ID contains the SIP Call ID as defined in the Session Initiation Protocol RFC 3261 [404]. This parameter corresponds to User-Session-ID.
Calling Party Address	O <sub>M</sub>	The address (Public User ID) of the party requesting a service or initiating a session. This field holds either the SIP URI (according to RFC 3261 [404]) or the TEL URI (according to RFC 3966 [405]) of the calling party. This parameter corresponds to Calling-Party-Address.
Called Party Address	O <sub>M</sub>	In the context of an end-to-end SIP transaction this field holds the address of the party (Public User ID) to whom the SIP transaction is posted. This parameter corresponds to Called-Party-Address.
Service Request Time Stamp	O <sub>M</sub>	This field contains the time stamp which indicates the time at which the service was requested. This parameter corresponds to SIP-Request-Timestamp in Charging Data Request[Start].
Service Delivery Start Time Stamp	O <sub>M</sub>	This field holds the time stamp reflecting either: successful session set-up, a delivery unrelated service, an unsuccessful session set-up and an unsuccessful session unrelated request. This parameter corresponds to SIP-Response-Timestamp in Charging Data Request[Start].
Service Delivery End Time Stamp	O <sub>C</sub>	This field records the time at which the service delivery was terminated. It is Present only in SIP session related case. This parameter corresponds to SIP-Request-Timestamp. in Charging Data Request[Stop].
Record Opening Time	O <sub>C</sub>	A time stamp reflecting the time the CDF opened this record. Present only in SIP session related case.
Record Closure Time	O <sub>M</sub>	A Time stamp reflecting the time the CDF closed the record.
Inter Operator Identifiers	O <sub>C</sub>	Holds the identification of the home network (originating and terminating) if exchanged via SIP signalling, as recorded in the <i>Inter-Operator-Identifier</i> .
Originating IOI	O <sub>C</sub>	This parameter corresponds to Originating-IOI.
Terminating IOI	O <sub>C</sub>	This parameter corresponds to Terminating-IOI.
Local Record Sequence Number	O <sub>M</sub>	This field includes a unique record number created by this node. The number is allocated sequentially for each partial CDR (or whole CDR) including all CDR types. The number is unique within the CDF.
Record Sequence Number	O <sub>C</sub>	This field contains a running sequence number employed to link the partial records generated by the CDF for a particular session.
Cause For Record Closing	O <sub>M</sub>	This field contains a reason for the release of the CDR.
Incomplete CDR Indication	O <sub>C</sub>	This field provides additional diagnostics when the CDF detects missing Charging Data Requests.
IMS Charging Identifier	O <sub>M</sub>	This parameter holds the IMS charging identifier (ICID) as generated by the IMS node for the SIP session. This parameter corresponds to IMS-Charging-Identifier (ICID).
SDP Session Description	O <sub>C</sub>	Holds the Session portion of the SDP data exchanged between the User Agents if available in the SIP transaction. This parameter corresponds to SDP-Session-Description.
List of SDP Media Components	O <sub>C</sub>	This is a grouped field comprising several sub-fields associated with one media component. It may occur several times in one CDR. The field is present only in a SIP session related case.
SIP Request Timestamp	O <sub>M</sub>	This parameter contains the time of the SIP Request (usually a (Re)Invite). This parameter corresponds to SIP-Request-Timestamp in INTERIM Charging Data Request.
SIP Response Timestamp	O <sub>M</sub>	This parameter contains the time of the response to the SIP Request (usually a 200 OK). This parameter corresponds to SIP-Response-Timestamp in INTERIM Charging Data Request.
SDP Media Components	O <sub>M</sub>	This is a grouped field comprising several sub-fields associated with one media component. Since several media components may exist for a session in parallel these sub-fields may occur several times. This parameter corresponds to SDP-Media-Component.
SDP Media Name	O <sub>M</sub>	This field holds the name of the media as available in the SDP data. This parameter corresponds to SDP-Media-Name.
SDP Media Description	O <sub>M</sub>	This field holds the attributes of the media as available in the SDP data. This parameter corresponds to SDP-Media-Description.
GPRS Charging ID	O <sub>C</sub>	This parameter holds the GPRS charging ID (GCID) which is generated by the GGSN for a GPRS PDP context. This parameter corresponds to GPRS-Charging-Id.

Field	Category	Description
Media Initiator Flag	O <sub>C</sub>	This field indicates if the called party has requested the session modification and it is present only if the initiator was the called party.
Media Initiator Party	O <sub>C</sub>	This field indicates the address (SIP URI or TEL URI) of the party (Public User ID or Public Service ID) who initiates the media action, like adding/removing the media.
GGSN Address	O <sub>C</sub>	This parameter holds the control plane IP address of the GGSN that handles one or more media component(s) of a IMS session. This parameter corresponds to the P-Charging-Vector header.
Service Delivery Failure Reason	O <sub>C</sub>	Holds the reason for why a requested service could not be successfully provided (i.e. SIP error codes taken from <i>SIP-Method</i> ). This field is not present in case of a successful service delivery.
Service Specific Data	O <sub>C</sub>	This field contains service specific data.
List of Message Bodies	O <sub>C</sub>	This grouped field comprising several sub-fields describing the data that may be conveyed end-to-end in the body of a SIP message. Since several message bodies may be exchanged via SIP-signalling, this grouped field may occur several times.
Content Type	O <sub>C</sub>	This sub-field of Message Bodies holds the MIME type of the message body, Examples are: application/zip, image/gif, audio/mpeg, etc. This parameter corresponds to Event-Type / Content-Type.
Content Disposition	O <sub>C</sub>	This sub-field of Message Bodies holds the content disposition of the message body inside the SIP signalling, Content-disposition header field equal to "render", indicates that "the body part should be displayed or otherwise rendered to the user". Content disposition values are: session, render, inline, icon, alert, attachment, etc. This parameter corresponds to Event-Type / Content-Disposition.
Content Length	O <sub>C</sub>	This sub-field of Message Bodies holds the size of the data of a message body in bytes. This parameter corresponds to Event-Type / Content-Length.
Originator	O <sub>C</sub>	This sub-field of the "List of Message Bodies" indicates the originating party of the message body. This parameter corresponds to P-Asserted-Identity header.
PoC Information	O <sub>C</sub>	A set of PoC specific parameters such as PoC session Type, PoC Server Role and the accumulated send/received talk burst information of the participant. . See clause 6.3.1.2.
User Location Info	O <sub>C</sub>	This field holds information about the location of the user to the level of that made available to the PoC Server. If no location information is available then this parameter is not included.
Service Context Id	O <sub>M</sub>	Holds the context information to which the CDR belongs
Record Extensions	O <sub>C</sub>	A set of operator/manufacture specific extensions to the record, conditioned upon existence of an extension.

### 6.1.3.3.2 Controlling PoC Function

Table 6.1.3.3.2.1 contains the content of Controlling PoC Function (CPF) CDR.

**Table 6.1.3.3.2.1: Charging data of CPF-CDR**



Field	Category	Description
Record Type	M	Identifies the PoC service record.
Retransmission	O <sub>C</sub>	This parameter, when present, indicates that information from retransmitted Diameter Charging Data Requests has been used in this CDR.
SIP Method	O <sub>C</sub>	Specifies the SIP-method for which the CDR is generated. Only available in session unrelated cases. This parameter corresponds to Event-Type.
Node Address	O <sub>M</sub>	This item holds the address of the node providing the information for the CDR. This may either be the IP address or the FQDN of the IMS node generating the accounting data. This parameter corresponds to the <i>Origin-Host</i> .
Session ID	O <sub>M</sub>	The Session identification. For a SIP session the Session-ID contains the SIP Call ID as defined in the Session Initiation Protocol RFC 3261 [404]. This parameter corresponds to User-Session-ID.
Calling Party Address	O <sub>M</sub>	The address (Public User ID) of the party requesting a service or initiating a session. This field holds either the SIP URI (according to RFC 3261 [404]) or the TEL URI (according to RFC 3966 [405]) of the calling party. This parameter corresponds to Calling-Party-Address.
Called Party Address	O <sub>M</sub>	In the context of an end-to-end SIP transaction this field holds the address of the party (Public User ID) to whom the SIP transaction is posted. This parameter corresponds to Called-Party-Address.
Service Request Time Stamp	O <sub>M</sub>	This field contains the time stamp which indicates the time at which the service was requested. This parameter corresponds to SIP-Request-Timestamp in START Charging Data Request.
Service Delivery Start Time Stamp	O <sub>M</sub>	This field holds the time stamp reflecting either: successful session set-up, a delivery unrelated service, an unsuccessful session set-up and an unsuccessful session unrelated request. This parameter corresponds to SIP-Response-Timestamp in START Charging Data Request.
Service Delivery End Time Stamp	O <sub>C</sub>	This field records the time at which the service delivery was terminated. It is Present only in SIP session related case. This parameter corresponds to SIP-Request-Timestamp in STOP Charging Data Request.
Record Opening Time	O <sub>C</sub>	A time stamp reflecting the time the CDF opened this record. Present only in SIP session related case.
Record Closure Time	O <sub>M</sub>	A Time stamp reflecting the time the CDF closed the record.
Inter Operator Identifiers	O <sub>C</sub>	Holds the identification of the home network (originating and terminating) if exchanged via SIP signalling, as recorded in the <i>Inter-Operator-Identifier</i> .
Originating IOI	O <sub>C</sub>	This parameter corresponds to Originating-IOI.
Terminating IOI	O <sub>C</sub>	This parameter corresponds to Terminating-IOI.
Local Record Sequence Number	O <sub>M</sub>	This field includes a unique record number created by this node. The number is allocated sequentially for each partial CDR (or whole CDR) including all CDR types. The number is unique within the CDF.
Record Sequence Number	O <sub>C</sub>	This field contains a running sequence number employed to link the partial records generated by the CDF for a particular session.
Cause For Record Closing	O <sub>M</sub>	This field contains a reason for the release of the CDR.
Incomplete CDR Indication	O <sub>C</sub>	This field provides additional diagnostics when the CDF detects missing Charging Data Requests.
IMS Charging Identifier	O <sub>M</sub>	This parameter holds the IMS charging identifier (ICID) as generated by the IMS node for the SIP session. This parameter corresponds to IMS-Charging-Identifier (ICID).
SDP Session Description	O <sub>C</sub>	Holds the Session portion of the SDP data exchanged between the User Agents if available in the SIP transaction. This parameter corresponds to SDP-Session-Description.
List of SDP Media Components	O <sub>C</sub>	This is a grouped field comprising several sub-fields associated with one media component. It may occur several times in one CDR. The field is present only in a SIP session related case.
SIP Request Timestamp	O <sub>M</sub>	This parameter contains the time of the SIP Request (usually a (Re)Invite). This parameter corresponds to SIP-Request-Timestamp in INTERIM Charging Data Request.
SIP Response Timestamp	O <sub>M</sub>	This parameter contains the time of the response to the SIP Request (usually a 200 OK). This parameter corresponds to SIP-Response-Timestamp in INTERIM Charging Data Request.
SDP Media Components	O <sub>M</sub>	This is a grouped field comprising several sub-fields associated with one media component. Since several media components may exist for a session in parallel these sub-fields may occur several times. This parameter corresponds to SDP-Media-Component.
SDP Media Name	O <sub>M</sub>	This field holds the name of the media as available in the SDP data. This parameter corresponds to SDP-Media-Name.
SDP Media Description	O <sub>M</sub>	This field holds the attributes of the media as available in the SDP data. This parameter corresponds to SDP-Media-Description.
Media Initiator Flag	O <sub>C</sub>	This field indicates if the called party has requested the session modification and it is present only if the initiator was the called party.

Field	Category	Description
Media Initiator Party	O <sub>C</sub>	This field indicates the address (SIP URI or TEL URI) of the party (Public User ID or Public Service ID) who initiates the media action, like adding/removing the media.
GGSN Address	O <sub>C</sub>	This parameter holds the control plane IP address of the GGSN that handles one or more media component(s) of a IMS session. This parameter corresponds to the P-Charging-Vector header. For the controlling PoC Server, this is only included if the charged party is participating in the session.
Service Delivery Failure Reason	O <sub>C</sub>	Holds the reason for why a requested service could not be successfully provided (i.e. SIP error codes taken from <i>SIP-Method</i> ). This field is not present in case of a successful service delivery.
Service Specific Data	O <sub>C</sub>	This field contains service specific data.
List of Message Bodies	O <sub>C</sub>	This grouped field comprising several sub-fields describing the data that may be conveyed end-to-end in the body of a SIP message. Since several message bodies may be exchanged via SIP-signalling, this grouped field may occur several times.
Content Type	O <sub>C</sub>	This sub-field of Message Bodies holds the MIME type of the message body, Examples are: application/zip, image/gif, audio/mpeg, etc. This parameter corresponds to Event-Type / Content-Type.
Content Disposition	O <sub>C</sub>	This sub-field of Message Bodies holds the content disposition of the message body inside the SIP signalling, Content-disposition header field equal to "render", indicates that "the body part should be displayed or otherwise rendered to the user". Content disposition values are: session, render, inline, icon, alert, attachment, etc. This parameter corresponds to Event-Type / Content-Disposition.
Content Length	O <sub>C</sub>	This sub-field of Message Bodies holds the size of the data of a message body in bytes. This parameter corresponds to Event-Type / Content-Length.
Originator	O <sub>C</sub>	This sub-field of the "List of Message Bodies" indicates the originating party of the message body. This parameter corresponds to P-Asserted-Identity header.
PoC Information	O <sub>C</sub>	A set of PoC specific parameters such as PoC session Type, PoC Server Role, Number and List of Participants and the accumulated talk burst information during the PoC session. See clause 6.3.1.2.
User Location Info	O <sub>C</sub>	This field holds information about the location of the charged party to the level of that made available to the PoC Server. If no location information is available then this parameter is not included. For the controlling PoC Server, this additionally is only included if the charged party is participating in the session.
Service Context Id	O <sub>M</sub>	Holds the context information to which the CDR belongs
Record Extensions	O <sub>C</sub>	A set of operator/manufacture specific extensions to the record, conditioned upon existence of an extension.

## 6.2 Data description for PoC online charging

### 6.2.0 General

PoC online charging is using Debit / Reserve Units operation, with the two messages Debit / Reserve Units Request and Debit / Reserve Units Reponse. The request performs rating of the PoC service and reserves units on the users account. The answer replies back with amount of reserved units or an error code if the user is out of credit.

Detailed information about the used of Diameter Credit-Control Application is described in TS 32.299 [50]

Table 6.2.0.1 describes the use of these messages for online charging.

**Table 6.2.0.1: Online charging messages reference table**

Message	Source	Destination
Debit / Reserve Units Request	PoC Server	OCS
Debit / Reserve Units Reponse	OCS	PoC Server

The structure of the Debit / Reserve Units Request and Debit / Reserve Units Reponse messages defined in the following clauses. The category in the tables are used according to the charging data configuration defined in clause 5.4 of TS 32.240 [1].

#### 6.2.1 Ro message contents

Void.

### 6.2.1.1 Debit / Reserve Units Request message

Table 6.2.1.1 illustrates the basic structure of a Debit / Reserve Units Request message from the PoC Server as used for PoC online charging.

**Table 6.2.1.1: Debit / Reserve Units Request message contents**

Information Element	Category	Description
Session Identifier	M	Used as described in TS 32.299 [50].
Originator Host	M	Used as described in TS 32.299 [50].
Originator Domain	M	Used as described in TS 32.299 [50].
Destination Domain	M	Used as described in TS 32.299 [50].
Operation Identifier	M	Used as described in TS 32.299 [50].
Operation Token	M	Used as described in TS 32.299 [50].
Operation Type	M	Used as described in TS 32.299 [50].
Operation Number	M	Used as described in TS 32.299 [50].
Destination Host	O <sub>C</sub>	Used as described in TS 32.299 [50].
User Name	O <sub>C</sub>	Used as described in TS 32.299 [50].
Origination State	O <sub>C</sub>	Used as described in TS 32.299 [50].
Origination Timestamp	O <sub>C</sub>	Used as described in TS 32.299 [50].
Subscriber Identifier	O <sub>C</sub>	Used as described in TS 32.299 [50].
Termination Cause	O <sub>C</sub>	Used as described in TS 32.299 [50].
Requested -Action	O <sub>C</sub>	Used as described in TS 32.299 [50].
Multiple Operation	O <sub>M</sub>	Used as described in TS 32.299 [50].
Multiple Unit Operation	O <sub>C</sub>	Used as described in TS 32.299 [50].
Subscriber Equipment Number	-	Not used in PoC charging.
Proxy Information	-	Not used.
Route Information	O <sub>C</sub>	Used as described in TS 32.299 [50].
Service-Information	O <sub>M</sub>	This field holds the PoC specific parameter and is described in clause 6.3.

The protocol specific parameter definition is specified in TS 32.299 [50].

## 6.2.1.2 Debit / Reserve Units Response message

Table 6.2.1.2.1 illustrates the basic structure of a Debit / Reserve Units Response message as used for the PoC Server. This message is always used by the OCS as specified below, independent of the receiving PoC Server and the Debit / Reserve Units Request request type that is being replied to.

**Table 6.2.1.2.1: Debit / Reserve Units Response message**

Information Element	Category	Description
Session Identifier	M	Used as described in TS 32.299 [50].
Operation Result	M	Used as described in TS 32.299 [50].
Originator Host	M	Used as described in TS 32.299 [50].
Originator Domain	M	Used as described in TS 32.299 [50].
Operation Identifier	M	Used as described in TS 32.299 [50].
Operation Type	M	Used as described in TS 32.299 [50].
Operation Number	M	Used as described in TS 32.299 [50].
Operation Failover	O <sub>c</sub>	Used as described in TS 32.299 [50].
Multiple Unit Operation	O <sub>c</sub>	Used as described in TS 32.299 [50].
Operation Failure Action	O <sub>c</sub>	Used as described in TS 32.299 [50].
Operation Event Failure Action	-	Not used in PoC charging.
Redirection Host	O <sub>c</sub>	Used as described in TS 32.299 [50].
Redirection Host Usage	O <sub>c</sub>	Used as described in TS 32.299 [50].
Redirection Cache Time	O <sub>c</sub>	Used as described in TS 32.299 [50].
Proxy Information	-	Not used in PoC charging .
Route Information	O <sub>c</sub>	Used as described in TS 32.299 [50].
Failed parameter	O <sub>c</sub>	Used as described in TS 32.299 [50].

## 6.3 PoC charging specific parameters

### 6.3.1 Definition of the PoC charging information

#### 6.3.1.0 General

The PoC Information parameter used for PoC charging is provided in the Service Information parameter.

#### 6.3.1.1 PoC charging information assignment for Service Information

The components that are used for PoC charging are provided in the Service Information as described in table 6.3.1.1.1.

**Table 6.3.1.1.1: Components of the Service Information used for PoC charging**

Information Element	Category	Description
Service Information	O <sub>M</sub>	A set of fields hold the 3GPP specific parameter as defined in TS 32.299 [50]. For MMS Charging the PS Information, IMS Information and PoC Information are used.
Subscriber Identifier	O <sub>M</sub>	Used as defined in TS 32.260 [20].
PS Information	O <sub>C</sub>	A set of fields hold the PS specific parameters. The details are defined in TS 32.251 [11].
User Location Info	O <sub>C</sub>	Used as defined in TS 32.251 [11].
GGSN Address	O <sub>C</sub>	Used as defined in TS 32.251 [11].
IMS Information	O <sub>C</sub>	A set of fields hold the IMS specific parameters. The details are defined in TS 32.260 [20].
Event Type	O <sub>C</sub>	Used as defined in TS 32.260 [20].
User Session ID	O <sub>C</sub>	Used as defined in TS 32.260 [20].
Calling Party Address	O <sub>C</sub>	Used as defined in TS 32.260 [20].
Called Party Address	O <sub>C</sub>	Used as defined in TS 32.260 [20].
Time stamp	O <sub>C</sub>	Used as defined in TS 32.260 [20].
Inter Operator Identifier	O <sub>C</sub>	Used as defined in TS 32.260 [20].
IMS Charging Identifier	O <sub>C</sub>	Used as defined in TS 32.260 [20].
SDP Session Description	O <sub>C</sub>	Used as defined in TS 32.260 [20].
SDP Media Components	O <sub>C</sub>	Used as defined in TS 32.260 [20].
Cause Code	O <sub>C</sub>	Used as defined in TS 32.260 [20].
PoC Information	O <sub>M</sub>	A set of fields hold the PoC specific parameters. The details are defined in clause 6.3.1.2.

### 6.3.1.2 Definition of the PoC Information

PoC specific charging information is provided within the PoC\_Information. The detailed structure of the PoC\_Information can be found in table 6.3.1.2.1.

**Table 6.3.1.2.1: Structure of the PoC Information**

Information Element	Category	Description
PoC Server Role	O <sub>M</sub>	Identifies the PoC Server as participating or controlling PoC Server.
PoC User Role	O <sub>C</sub>	Identifies the PoC user's role detailed information which should be a list of roles information group. See further details in OMA-AD-POC document [203].
PoC Session Type	O <sub>M</sub>	Type of the PoC session as defined in appendix C.5.1 in OMA-CP-POC [204].
Number Of Participants	O <sub>M</sub>	Indicates the number of invited parties of the PoC session when included in the initial charging request message. When included in interim / update charging messages, it indicates the number of parties currently who are attached to the session at the time the interim / update charging messages are sent.
List Of Participants	O <sub>C</sub>	Holds the information for participants, e.g., the addresses, the access priority, the user participating type of the invited parties of the PoC session when included in the initial charging request message. When included in the interim /update charging messages, it holds the addresses and access priority of the parties currently who are attached to the session at the time the interim / update charging messages are sent.
Called Party Address	O <sub>C</sub>	The address (Public User ID, SIP URL, E.164, etc.) of the participants.
Participant Access Priority	O <sub>C</sub>	Indicates the user priority level when participating in the PoC session.
User Participating Type	O <sub>C</sub>	Indicates the participating user type when participating in the PoC session, i.e. Normal, NW PoC Box, UE PoC Box.
PoC Session initiation type	O <sub>C</sub>	Indicates PoC session initiation type. It can be only used for the served parties.
PoC Event Type	O <sub>C</sub>	Indicates PoC session unrelated charging event.
List Of Talk Burst-Exchange	O <sub>C</sub>	Applicable to offline charging only - a list of changes in charging conditions for the PoC session, each change is time stamped. Charging conditions are used to categorize charging, such as per tariff period or based on the number of participants. A set of charging data (number of talk bursts, talk burst bearer volume, sum of talk bursts time) for sent and received talk burst.
PoC Controlling Address	O <sub>C</sub>	Identifies the PoC Server performing the controlling function. This is only included when PoC Server Role indicates "participating". This information may be obtained from the "Contact" header of SIP message received from the controlling PoC function.
PoC Group Name	O <sub>C</sub>	Identifies a pre-arranged group. Included if the session is a pre-arranged group session. This information may be obtained from the "P-Asserted-Identity" header of the SIP message received from the controlling PoC function, or from the "Request-URI" header from the PoC user.
PoC Session Id	O <sub>C</sub>	Uniquely identifies an end-to-end PoC session. Note that the PoC Session-Id may not be available in the initial charging interactions for the PoC session.
Served Party	O <sub>M</sub>	Applicable to offline charging only – holds the identity of the party that the charging information relates to.

## 6.3.2 Formal parameter description

### 6.3.2.1 PoC charging information for CDRs

The detailed definitions, abstract syntax and encoding of the PoC CDR parameters are specified in TS 32.298 [51].

### 6.3.2.2 PoC charging information for charging events

The detailed charging event parameter definitions are specified in TS 32.299 [50].



---

## Annex A (informative): Bibliography

This Annex is a placeholder for documents which are not explicitly cited in this specification.

## Annex B (informative): Change history

Change history								
Date	TSG #	TSG Doc.	CR	Rev	Subject/Comment	Cat	Old	New
Jun 2006	SA_32	SP-060248	0013	--	Add charging flow for mid PoC session Procedure	B	6.4.0	7.0.0
Jun 2006	SA_32	SP-060248	0014	--	Add a new field named PoC_user_role to PoC_Information - Align with OMA PoC 2.0	B	6.4.0	7.0.0
Sep 2006	SA_33	SP-060516	0016	--	Clarify the description of Number-Of-Participants in PoC-information	A	7.0.0	7.1.0
Sep 2006	SA_33	SP-060543	0017	--	Correction of PoC-Information - Align with 32.299	C	7.0.0	7.1.0
Dec 2006	SA_34	SP-060718	0018	-	Add an identifier for the service initiating offline Diameter Accounting	B	7.1.0	7.2.0
Dec 2006	SA_34	SP-060718	0019	-	Add an identifier for the served user in offline Diameter Accounting	B	7.1.0	7.2.0
Dec 2006	SA_34	SP-060718	0020	-	Add PoC User Access Priority into PoC-information - Align with OMA-RD-PoC-V2_0	B	7.1.0	7.2.0
Mar 2007	SA_35	SP-070041	0021	--	Add Participant number based charging Trigger Type	C	7.2.0	7.3.0
Mar 2007	SA_35	SP-070041	0022	--	Add PoC session initiation type into PoC-information - Alignment with OMA PoC Requirements	C	7.2.0	7.3.0
Jun 2007	SA_36	SP-070275	0023	-	Add User Participating Type into PoC-information	B	7.3.0	7.4.0
Jun 2007	SA_36	SP-070275	0024	-	Addition of Media Initiator Party.	F	7.3.0	7.4.0
Jun 2008	SA_40	SP-080330	0025	-	PoC Information	B	7.4.0	8.0.0
Sep 2008	SA_41	SP-081253	0026	--	Alignment on Bx interface	D	8.0.0	8.1.0
Dec 2008	SA_42	SP-080841	0028	-	Correction on Multiple Service Indicator category	A	8.1.0	8.2.0
Dec 2009	-	-	-	-	Update to Rel-9 version (MCC)	-	8.2.0	9.0.0
Mar 2011	-	-	-	-	Update to Rel-10 version (MCC)	-	9.0.0	10.0.0
2012-09	-	-	-	-	Update to Rel-11 version (MCC)	-	10.0.0	11.0.0
2013-12	SA_62	SP-130676	0033	-	Correction for use of Destination-Host AVP in ACR	A	11.0.0	11.1.0
2014-07	-	-	-	-	Rapporteur/MCC: General editorial changes and clean-up.	-	11.1.0	11.1.1
2014-09	SA_65	SP-140564	0034	1	Corrections for alignment between charging specifications	F	11.1.1	12.0.0
2014-12	SA_66	SP-140804	0035	1	Additional corrections for removal of I-WLAN solution	F	12.0.0	12.1.0
		SP-140805	0036	-	Corrections on definition for parameter category			
2016-01					Upgrade to Rel-13 (MCC)		12.1.0	13.0.0

Change history							
Date	Meeting	TDoc	CR	Rev	Cat	Subject/Comment	New version
2017-03	SA#75	SP-170138	0038	1	C	Remove reference to RFC 3588	14.0.0
2018-06	-	-	-	-	-	Update to Rel-15 version (MCC)	15.0.0
2020-07	-	-	-	-	-	Update to Rel-16 version (MCC)	16.0.0

---

# History

<b>Document history</b>		
V16.0.0	August 2020	Publication