

ETSI TS 132 279 V18.1.0 (2024-07)



**5G;
Charging management;
5G Multicast-broadcast Services charging
(3GPP TS 32.279 version 18.1.0 Release 18)**



Reference

RTS/TSGS-0532279vi10

Keywords

5G

ETSI

650 Route des Lucioles
F-06921 Sophia Antipolis Cedex - FRANCE

Tel.: +33 4 92 94 42 00 Fax: +33 4 93 65 47 16

Siret N° 348 623 562 00017 - APE 7112B
Association à but non lucratif enregistrée à la
Sous-Préfecture de Grasse (06) N° w061004871

Important notice

The present document can be downloaded from the
ETSI [Search & Browse Standards application](#).

The present document may be made available in electronic versions and/or in print. The content of any electronic and/or print versions of the present document shall not be modified without the prior written authorization of ETSI. In case of any existing or perceived difference in contents between such versions and/or in print, the prevailing version of an ETSI deliverable is the one made publicly available in PDF format on [ETSI deliver](#).

Users should be aware that the present document may be revised or have its status changed,
this information is available in the [Milestones listing](#).

If you find errors in the present document, please send your comments to
the relevant service listed under [Committee Support Staff](#).

If you find a security vulnerability in the present document, please report it through our
[Coordinated Vulnerability Disclosure \(CVD\)](#) program.

Notice of disclaimer & limitation of liability

The information provided in the present deliverable is directed solely to professionals who have the appropriate degree of experience to understand and interpret its content in accordance with generally accepted engineering or other professional standard and applicable regulations.

No recommendation as to products and services or vendors is made or should be implied.

No representation or warranty is made that this deliverable is technically accurate or sufficient or conforms to any law and/or governmental rule and/or regulation and further, no representation or warranty is made of merchantability or fitness for any particular purpose or against infringement of intellectual property rights.

In no event shall ETSI be held liable for loss of profits or any other incidental or consequential damages.

Any software contained in this deliverable is provided "AS IS" with no warranties, express or implied, including but not limited to, the warranties of merchantability, fitness for a particular purpose and non-infringement of intellectual property rights and ETSI shall not be held liable in any event for any damages whatsoever (including, without limitation, damages for loss of profits, business interruption, loss of information, or any other pecuniary loss) arising out of or related to the use of or inability to use the software.

Copyright Notification

No part may be reproduced or utilized in any form or by any means, electronic or mechanical, including photocopying and microfilm except as authorized by written permission of ETSI.

The content of the PDF version shall not be modified without the written authorization of ETSI.

The copyright and the foregoing restriction extend to reproduction in all media.

© ETSI 2024.
All rights reserved.

Intellectual Property Rights

Essential patents

IPRs essential or potentially essential to normative deliverables may have been declared to ETSI. The declarations pertaining to these essential IPRs, if any, are publicly available for **ETSI members and non-members**, and can be found in ETSI SR 000 314: "*Intellectual Property Rights (IPRs); Essential, or potentially Essential, IPRs notified to ETSI in respect of ETSI standards*", which is available from the ETSI Secretariat. Latest updates are available on the ETSI Web server (<https://ipr.etsi.org/>).

Pursuant to the ETSI Directives including the ETSI IPR Policy, no investigation regarding the essentiality of IPRs, including IPR searches, has been carried out by ETSI. No guarantee can be given as to the existence of other IPRs not referenced in ETSI SR 000 314 (or the updates on the ETSI Web server) which are, or may be, or may become, essential to the present document.

Trademarks

The present document may include trademarks and/or tradenames which are asserted and/or registered by their owners. ETSI claims no ownership of these except for any which are indicated as being the property of ETSI, and conveys no right to use or reproduce any trademark and/or tradename. Mention of those trademarks in the present document does not constitute an endorsement by ETSI of products, services or organizations associated with those trademarks.

DECT™, **PLUGTESTS™**, **UMTS™** and the ETSI logo are trademarks of ETSI registered for the benefit of its Members. **3GPP™** and **LTE™** are trademarks of ETSI registered for the benefit of its Members and of the 3GPP Organizational Partners. **oneM2M™** logo is a trademark of ETSI registered for the benefit of its Members and of the oneM2M Partners. **GSM®** and the GSM logo are trademarks registered and owned by the GSM Association.

Legal Notice

This Technical Specification (TS) has been produced by ETSI 3rd Generation Partnership Project (3GPP).

The present document may refer to technical specifications or reports using their 3GPP identities. These shall be interpreted as being references to the corresponding ETSI deliverables.

The cross reference between 3GPP and ETSI identities can be found under <https://webapp.etsi.org/key/queryform.asp>.

Modal verbs terminology

In the present document "**shall**", "**shall not**", "**should**", "**should not**", "**may**", "**need not**", "**will**", "**will not**", "**can**" and "**cannot**" are to be interpreted as described in clause 3.2 of the [ETSI Drafting Rules](#) (Verbal forms for the expression of provisions).

"**must**" and "**must not**" are **NOT** allowed in ETSI deliverables except when used in direct citation.

Contents

Intellectual Property Rights	2
Legal Notice	2
Modal verbs terminology.....	2
Foreword.....	5
1 Scope	7
2 References	7
3 Definitions of terms, symbols and abbreviations	8
3.1 Terms.....	8
3.2 Symbols.....	8
3.3 Abbreviations	8
4 Architecture considerations	9
4.1 5G System architecture for Multicast and Broadcast Service	9
4.2 5G MBS Session converged charging architecture	9
5 5G MBS Session charging principles and scenarios	10
5.1 5G MBS Session charging principles.....	10
5.1.1 General.....	10
5.1.2 Requirements	10
5.1.3 Charging information.....	10
5.1.4 Charging Identifier.....	11
5.1.5 CHF selection	11
5.2 5G MBS Session converged charging scenarios	11
5.2.1 Basic principles.....	11
5.2.1.1 General	11
5.2.1.2 Applicable Triggers in the MB-SMF	12
5.2.1.3 MBS session charging.....	14
5.2.2 Message flows	14
5.2.2.1 General	14
5.2.2.2 5G MBS charging for multicast and broadcast communication.....	15
5.2.2.2.1 General	15
5.2.2.2.2 MBS session creation	15
5.2.2.2.3 MBS session deletion	15
5.2.2.2.4 MBS session establishment for broadcast	16
5.2.2.2.5 Establishment of shared delivery towards RAN node for multicast	17
5.2.2.2.6 Establishment of individual delivery towards UPF for multicast	18
5.2.2.2.7 MBS session release for multicast.....	19
5.2.2.2.8 MBS session activation for multicast	20
5.2.2.2.9 MBS session deactivation for multicast	21
5.2.2.2.10 MBS Session Update Charging Procedure	21
5.2.3 CDR generation	22
5.2.3.1 Introduction.....	22
5.2.3.2 Triggers for CHF CDR.....	22
5.2.3.2.1 General	22
5.2.3.2.2 Triggers for CHF CDR charging information addition	22
5.2.3.2.3 Triggers for CHF CDR partial record closure	23
5.2.3.2.4 Triggers for CHF CDR closure	23
5.2.4 Ga record transfer flows	23
5.2.5 Bmbs CDR file transfer	23
6 Definition of charging information	24
6.1 Data description for 5G MBS Session charging.....	24
6.1.1 Message contents	24
6.1.1.1 General	24
6.1.1.2 Charging Data Request message	25

6.1.1.3	Charging data response message.....	26
6.1.2	Ga message contents.....	26
6.1.3	CDR description on the B _{mbs} interface.....	26
6.1.3.1	General.....	26
6.1.3.2	MBS session charging CHF CDR data.....	26
6.2	5G MBS Session charging specific parameters.....	27
6.2.1	Definition of 5G MBS Session charging information.....	27
6.2.1.1	General.....	27
6.2.1.2	Definition of MBS session charging information.....	27
6.2.1.3	Definition of MBS container information.....	28
6.2.2	Detailed message format for converged charging.....	28
6.2.3	Formal 5G MBS Session charging parameter description.....	30
6.2.3.1	5G MBS Session CHF CDR parameters.....	30
6.2.3.2	5G MBS Session resources attributes.....	30
6.3	Bindings for 5G MBS Session charging.....	30
Annex A (informative): Change history		31
History		32

Foreword

This Technical Specification has been produced by the 3rd Generation Partnership Project (3GPP).

The contents of the present document are subject to continuing work within the TSG and may change following formal TSG approval. Should the TSG modify the contents of the present document, it will be re-released by the TSG with an identifying change of release date and an increase in version number as follows:

Version x.y.z

where:

- x the first digit:
 - 1 presented to TSG for information;
 - 2 presented to TSG for approval;
 - 3 or greater indicates TSG approved document under change control.
- y the second digit is incremented for all changes of substance, i.e. technical enhancements, corrections, updates, etc.
- z the third digit is incremented when editorial only changes have been incorporated in the document.

In the present document, modal verbs have the following meanings:

- shall** indicates a mandatory requirement to do something
- shall not** indicates an interdiction (prohibition) to do something

The constructions "shall" and "shall not" are confined to the context of normative provisions, and do not appear in Technical Reports.

The constructions "must" and "must not" are not used as substitutes for "shall" and "shall not". Their use is avoided insofar as possible, and they are not used in a normative context except in a direct citation from an external, referenced, non-3GPP document, or so as to maintain continuity of style when extending or modifying the provisions of such a referenced document.

- should** indicates a recommendation to do something
- should not** indicates a recommendation not to do something
- may** indicates permission to do something
- need not** indicates permission not to do something

The construction "may not" is ambiguous and is not used in normative elements. The unambiguous constructions "might not" or "shall not" are used instead, depending upon the meaning intended.

- can** indicates that something is possible
- cannot** indicates that something is impossible

The constructions "can" and "cannot" are not substitutes for "may" and "need not".

- will** indicates that something is certain or expected to happen as a result of action taken by an agency the behaviour of which is outside the scope of the present document
- will not** indicates that something is certain or expected not to happen as a result of action taken by an agency the behaviour of which is outside the scope of the present document
- might** indicates a likelihood that something will happen as a result of action taken by some agency the behaviour of which is outside the scope of the present document

might not indicates a likelihood that something will not happen as a result of action taken by some agency the behaviour of which is outside the scope of the present document

In addition:

is (or any other verb in the indicative mood) indicates a statement of fact

is not (or any other negative verb in the indicative mood) indicates a statement of fact

The constructions "is" and "is not" do not indicate requirements.

1 Scope

The present document is part of a series of documents that specify charging functionality and charging management in 3GPP networks. The 3GPP core network charging architecture and principles are specified in TS 32.240 [2], which provides an umbrella for other charging management TSs that specify:

- the content of the CDRs per domain / subsystem / service (offline charging);
- the content of real-time charging messages per domain / subsystem / service (online charging);
- the functionality of online and offline charging for those domains / subsystems / services;
- the interfaces that are used in the charging framework to transfer the charging information (i.e. CDRs or charging events).

The complete document structure for these TSs is defined in TS 32.240 [2].

The present document specifies the converged charging description for the 5G MBS Session based on the functional stage 2 description in TS 23.247 [9], TS 23.501 [10], TS 23.502 [11] and TS 23.503 [12].

This charging description includes the converged charging architecture and scenarios specific to the 5G MBS Session, with focus on the following charging scenarios:

- MBS session charging for multicast communication.
- MBS session charging for broadcast communication.

It further specifies the structure and content of the CDRs and the charging events for converged charging.

All references, abbreviations, definitions, descriptions, principles and requirements, used in the present document, that are common across 3GPP TSs, are defined in TR 21.905 [1]. Those that are common across charging management in 3GPP networks/domains, services or subsystems are provided in the umbrella TS 32.240 [2] and are copied into clause 3 of the present document for ease of reading. Finally, those items that are specific to the present document are defined exclusively in the present document.

2 References

The following documents contain provisions which, through reference in this text, constitute provisions of the present document.

- References are either specific (identified by date of publication, edition number, version number, etc.) or non-specific.
- For a specific reference, subsequent revisions do not apply.
- For a non-specific reference, the latest version applies. In the case of a reference to a 3GPP document (including a GSM document), a non-specific reference implicitly refers to the latest version of that document *in the same Release as the present document*.

- [1] 3GPP TR 21.905: "Vocabulary for 3GPP Specifications".
- [2] 3GPP TS 32.240: "Telecommunication management; Charging management; Charging architecture and principles".
- [3] 3GPP TS 32.255: "Telecommunication management; Charging management; 5G Data connectivity domain charging; stage 2".
- [4] 3GPP TS 32.290: "Telecommunication management; Charging management; 5G system; Services, operations and procedures of charging using Service Based Interface (SBI)".
- [5] 3GPP TS 32.291: "Telecommunication management; Charging management; 5G system; Charging service, stage 3".

- [6] 3GPP TS 32.295: "Telecommunication management; Charging management; Charging Data Record (CDR) transfer".
- [7] 3GPP TS 32.297: "Telecommunication management; Charging management; Charging Data Record (CDR) file format and transfer".
- [8] 3GPP TS 32.298: "Telecommunication management; Charging management; Charging Data Record (CDR) parameter description".
- [9] 3GPP TS 23.247: "Architectural enhancements for 5G multicast-broadcast services; Stage 2".
- [10] 3GPP TS 23.501: "System Architecture for the 5G System; Stage 2".
- [11] 3GPP TS 23.502: "Procedures for the 5G System".
- [12] 3GPP TS 23.503: "Policy and Charging Control Framework for the 5G System; Stage 2".

3 Definitions of terms, symbols and abbreviations

3.1 Terms

For the purposes of the present document, the terms given in 3GPP TR 21.905 [1] and the following apply. A term defined in the present document takes precedence over the definition of the same term, if any, in 3GPP TR 21.905 [1].

3.2 Symbols

For the purposes of the present document, the following symbols apply:

Bmbs	Reference point for the CDR file transfer from the 5G MBS Session CGF to the BD.
Ga	Reference point for CDR transfer between a CDF and the CGF.
Nchf	Service based interface exhibited by CHF.
N101	Reference point between MB-SMF and the CHF.

3.3 Abbreviations

For the purposes of the present document, the abbreviations given in 3GPP TR 21.905 [1] and the following apply. An abbreviation defined in the present document takes precedence over the definition of the same abbreviation, if any, in 3GPP TR 21.905 [1].

5GC	5G Core Network
5GS	5G System
AF	Application Function
AMF	Access and Mobility Management Function
BD	Billing Domain
CCS	Converged Charging System
CDF	Charging Data Function
CGF	Charging Gateway Function
CHF	Charging Function
CTF	Charging Trigger Function
FBC	Flow Based Charging
MBS	Multicast/Broadcast Service
MB-SMF	Multicast/Broadcast Session Management Function.
MB-UPF	Multicast/Broadcast User Plane Function
NF	Network Function
PCC	Policy and Charging Control
SMF	Session Management Function
UPF	User Plane Function

4 Architecture considerations

4.1 5G System architecture for Multicast and Broadcast Service

Figure 4.1-1 shows the non-roaming architecture for 5G Multicast and Broadcast Service as defined in TS 23.247 [9] for 5G data connectivity.

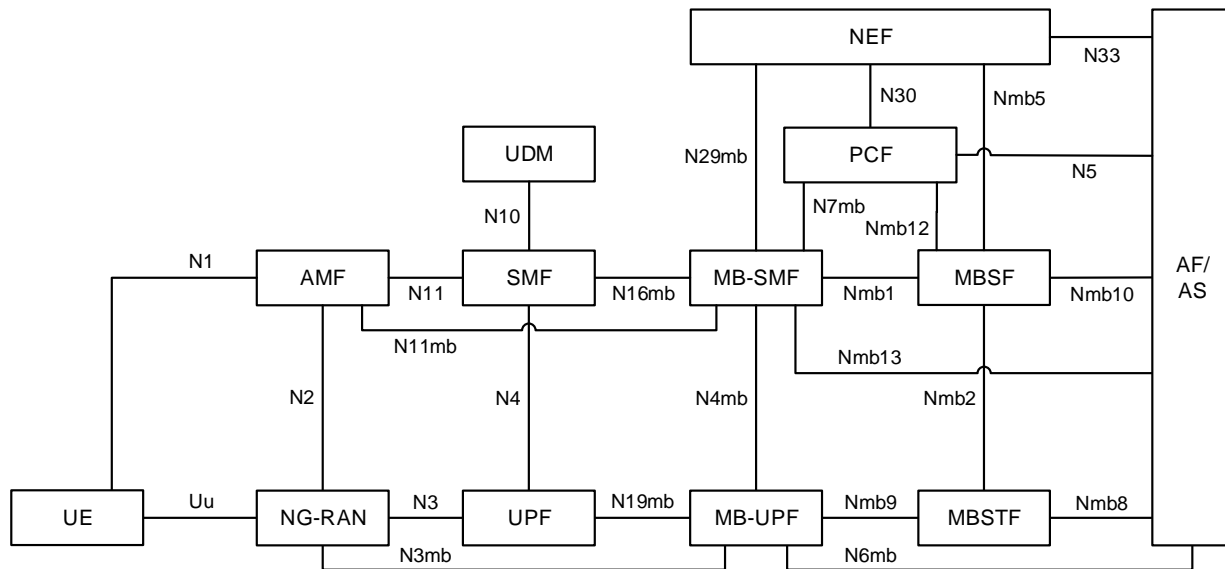

Figure 4.1-1: Non-roaming architecture for 5G Multicast and Broadcast Service in reference point representation

4.2 5G MBS Session converged charging architecture

In order to support MBS session charging, the MB-SMF embedding the CTF, generates charging events towards the CHF for converged charging.

Figure 4.2-1 depicts the 5G MBS architectural options for converged charging in service-based representation, with MB-SMF interacting with CHF.

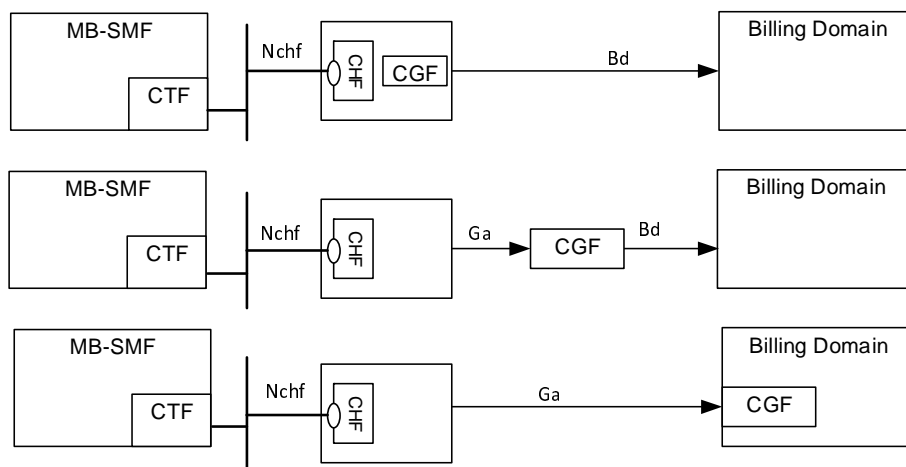

Figure 4.2-1: 5G converged charging architecture for MBS

Figure 4.2-2 depicts the 5G converged charging architecture for MBS in reference point representation:

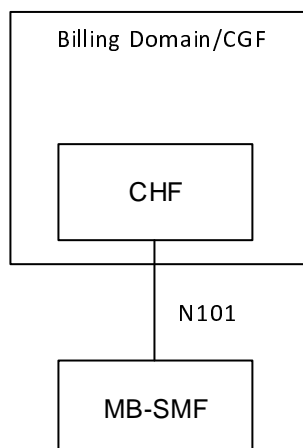

Figure 4.2-2: 5G converged charging architecture for MBS in reference point representation

The N101 reference point is defined for the interactions between MB-SMF and CHF in the reference point representation.

5 5G MBS Session charging principles and scenarios

5.1 5G MBS Session charging principles

5.1.1 General

The charging functions specified for the 5G MBS session charging:

- MBS session in MB-SMF, refer to TS 23.247 [9].

5.1.2 Requirements

The following are high-level charging requirements applicable if 5G MBS session charging is supported:

- The MB-SMF shall support converged charging..
- The MB-SMF shall support MBS session charging.
- The MB-SMF shall be capable of identifying duration (elapsed time) per MBS session.
- The MB-SMF may support quota management for duration.
- The MB-SMF may be capable of identifying transmitted volume per MBS session.
- The quota management shall be per rating group per MBS session.- Every MBS session shall be assigned a unique identity number for billing purposes per PLMN (i.e. the Charging Identifier).

5.1.3 Charging information

The MB-SMF may collect following charging information.

- usage of the access and core network resources: the amount of multicast or broadcast data transmitted;

- usage duration: counted as the time interval from MBS session creation to MBS session deletion;
- service area: the charging information describes the area over which the MBS session data is distributed. MBS service area provided by AF (clause 6.2 of TS 23.247 [9]), or a list of gNBs and UPFs that have established tunnels with MB-UPFs (clause 6.9 of TS 23.247 [9]).

For the multicast communication, the MB-SMF may report above charging information to CHF for the following cases.

- MBS session creation and deletion;
- Establishment and release of shared delivery towards gNBs;
- Establishment and release of individual delivery towards UPFs.

For the broadcast communication, MB-SMF may report above charging information to CHF for the following cases.

- MBS session creation, establishment and deletion.

5.1.4 Charging Identifier

Charging identifier is created to allow correlation of charging information.

For the MB-SMF, the charging identifier is assigned per MBS session. At each MBS session creation, a new MBS session specific Charging Identifier is generated at the Charging Data Request [Initial] as is defined in clause 5.2.2.2.2. The Charging Identifier shall be unique within the MB-SMF (that means that the charging identifier is unique within the MB-SMF set if MB-SMF set is used) which assigned it and is then used in all subsequent messages for that MBS session. The Charging Identifier shall be used throughout the MBS session's lifetime once assigned. In case of mobility procedures for MBS, the Charging Identifier is preserved while the MBS session ID is preserved.

5.1.5 CHF selection

The CHF Address(es) selection by the MB-SMF can be done at the MBS session creation based on the following options:

- NRF based discovery.
- MB-SMF locally provisioned charging characteristics.

The priority order between these options depends on Operator's policies.

5.2 5G MBS Session converged charging scenarios

5.2.1 Basic principles

5.2.1.1 General

Converged charging may be performed by the MB-SMF interacting with CHF using Nchf specified in TS 32.290 [4] and TS 32.291 [5]. The MB-SMF shall be able to perform converged charging for each of the following:

- Charging data related to MBS session with individual and shared traffic delivery for Multicast;
- Charging data related to MBS session for Broadcast;

For charging related to service data flows within the PDU session for multicast service, see TS 32.255 [3].

The MB-SMF shall be able to report charging events to CDF for CDR generation.

The MB-SMF shall be able to perform convergent charging by interacting with CHF, for charging data related to MBS sessions. The Charging Data Request and Charging Data Response are exchanged between the MB-SMF and the CHF, based on SCUR scenarios specified in TS 32.290 [4]. The Charging Data Request is issued by the MB-SMF towards the CHF when certain conditions (chargeable events) are met.

The MB-SMF initiates a charging session with Charging Data Request/Response [Initial], updates the charging session with Charging Data Request/Response [Update], and terminates the charging session with Charging Data Request/Response [Termination].

5.2.1.2 Applicable Triggers in the MB-SMF

When a charging event is issued towards the CHF, it includes details such as MBS charging identifier and also containers identifying the volume count, with charging condition change information.

Each trigger condition (i.e. chargeable event) defined for the 5G converged charging functionality with the associated behaviours when met is specified in the present document and the basic trigger mechanism is specified in the TS 32.290 [4].

Two categories of chargeable events are identified:

- immediate report: chargeable events for which, when occurring, the current counts are closed and sent together with the charging data generated by the MB-SMF towards the CHF in a Charging Data Request. New counts are started by the MB-SMF.
- deferred report: chargeable events for which, when occurring, the current counts are closed and stored together with the charging data generated by the MB-SMF. The stored counts will be sent to the CHF in next a Charging Data Request. New counts are started by the MB-SMF.

When more than one trigger condition to be met at same time (i.e. time stamp of triggers is the same) for the same count in the MB-SMF, the MB-SMF reports the used unit container with these triggers.

When a MBS session starts, and the converged charging is activated, the MB-SMF invokes a Charging Data Request [Initial] towards the CHF to get authorization to start based on the default triggers. The MB-SMF is optionally provided in a Charging Data Response [Initial] to override the default triggers, with a set of chargeable event triggers to be enabled, and the associated category (i.e. immediate or deferred report).

The triggers remain active until they are updated or disabled by subsequent Charging Data Response [Update] from the CHF or the MBS session is terminated.

Table 5.2.1.2-1 summarizes the set of default trigger conditions and their category which shall be supported by the MB-SMF. For "immediate report" category, the table also provides the corresponding Charging Data Request [Initial, Update, Termination] message sent from MB-SMF towards the CHF.

Table 5.2.1.2-1: Default Trigger conditions in MB-SMF

Trigger Conditions	Trigger level	Converged Charging default category	CHF allowed to change category	CHF allowed to enable and disable	Message when "immediate reporting" category	
Start of MBS Session.	MBS session	Immediate	Not Applicable	Not Applicable	Charging Data Request [Initial]	
Change of Charging conditions						
Connection established with NG-RAN	MBS session	Deferred	Yes	Yes	Charging Data Request [Update]	
Connection released with NG-RAN	MBS session	Deferred	Yes	Yes		
Connection established with UPF	MBS session	Deferred	Yes	Yes		
Tariff Time Change	MBS session	Deferred	Deferred	Yes		
Connection released with UPF	MBS session	Deferred	Yes	Yes		
MBS Session activity status change to active	MBS session	Immediate	Yes	Yes		
MBS Session activity status change to inactive	MBS session	Immediate	Yes	Yes		
Session Context Update	MBS session	Deferred	Yes	Yes		
Quota management						
Time threshold reached	RG	Immediate	No	Yes		
Time quota exhausted	RG	Immediate	No	Yes		
Limit per MBS session						
Expiry of data time limit per MBS session	MBS session	Immediate	No	Yes		
Expiry of data volume limit per MBS session	MBS session	Immediate	No	Yes		
Expiry of limit of number of charging condition changes	MBS session	Immediate	No	Yes		
End of MBS session	MBS session	Immediate	No	No	Charging Data Request [Termination]	

For converged charging, the following details of chargeable events and corresponding actions in the MB-SMF are defined in Table 5.2.1.2-2:

Table 5.2.1.2-2: Chargeable events and their related actions in MB-SMF

Chargeable event	Conditions	MB-SMF action
Start of MBS session		Charging Data Request [Initial].
Connection established with NG-RAN	If the corresponding trigger is enabled	Close the counts and start new counts with time stamps
Connection released with NG-RAN	If the corresponding trigger is enabled	Close the counts and start new counts with time stamps
Connection established with UPF	If the corresponding trigger is enabled	Close the counts and start new counts with time stamps
Connection released with UPF	If the corresponding trigger is enabled	Close the counts and start new counts with time stamps
MBS Session activity status change to active	If the corresponding trigger is enabled	Charging Data Request [Update] Start new counts with time stamps
MBS Session activity status change to inactive	If the corresponding trigger is enabled	Charging Data Request [Update] Close the counts with time stamps
Session Context update	If the corresponding trigger is enabled	Charging Data Request [Update] with a possible Service requirement change Close the counts and start new counts with time stamps
Time threshold reached	If the corresponding trigger is enabled	Charging Data Request [Update] with a possible request quota Close the counts and start new counts with time stamps
Time quota exhausted	If the corresponding trigger is enabled	Charging Data Request [Update] with a possible request quota Close the counts and start new counts with time stamps
Expiry of data volume limit per MBS session	If the corresponding trigger is enabled	Charging Data Request [Update] Close the counts and start new counts with time stamps
Expiry of time limit per MBS session	If the corresponding trigger is enabled	Charging Data Request [Update] Close the counts and start new counts with time stamps
Expiry of a limit of number of charging condition changes per MBS session	If the corresponding trigger is enabled	Charging Data Request [Update] Close the counts and start new counts with time stamps
Tariff Time Change	If the corresponding trigger is enabled	Charging Data Request [Update] with a possible request quota Close the counts and start new counts with time stamps
End of MBS session		Charging Data Request [Termination] Close the counts with time stamps

5.2.1.3 MBS session charging

Converged charging allows the MB-SMF to collect charging information related to duration of MBS session or data volumes of MBS data packets received from AF or MBSTF per MBS session.

5.2.2 Message flows

5.2.2.1 General

The flows in the present document specify the interaction between the MB-SMF and the CHF for 5G MBS session converged charging functionality, in different scenarios, based on TS 23.247 [9] procedures and flows.

This interaction is based on Charging Data Request /Response specified in TS 32.290 [4], exchanged between the MB-SMF embedding the CTF and the CHF.

As a general principle, the steps in the figures for the message flows below correspond to the steps of figures in TS 23.247 [9], which is the reference. The present document specifies the charging specific extension part.

5.2.2.2 5G MBS charging for multicast and broadcast communication

5.2.2.2.1 General

This clause specifies MBS session charging for multicast and broadcast communication as defined in TS 23.247 [9].

5.2.2.2.2 MBS session creation

The following figure 5.2.2.2.2-1 describes the charging procedure for MBS session creation, based on TS 23.247 [9] figures 7.1.1.2-1 and 7.1.1.3-1.

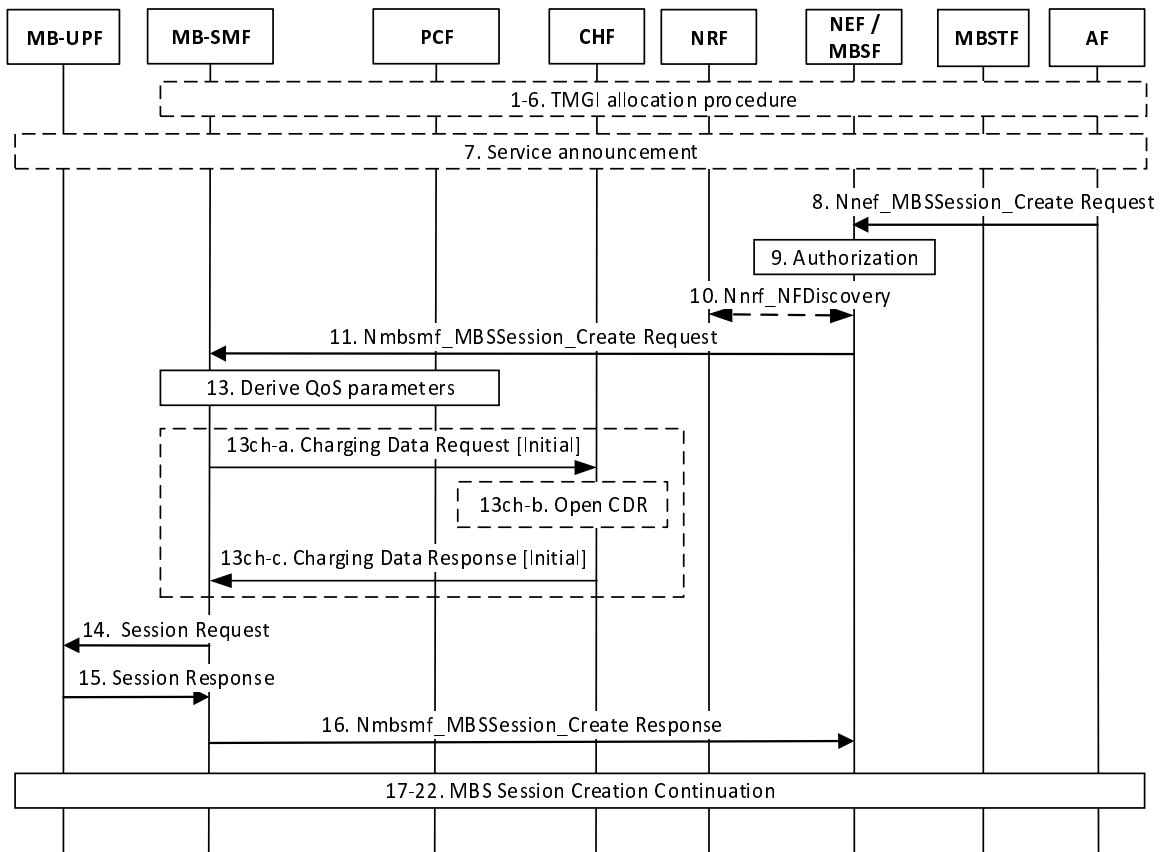

Figure 5.2.2.2.2-1: MBS session creation

Steps 1 to 11 per 3GPP TS 23.247 [9] Figure 7.1.1.2-1: MBS Session Creation without PCC.

13. If the dynamic PCC is deployed, refer to steps 21-27 in TS 23.247 [9] Figure 7.1.1.3-1: MBS Session Creation with PCC. If not, refer to step 13 in TS 23.247 [9] Figure 7.1.1.2-1: MBS Session Creation without PCC.

13ch-a. The MB-SMF sends Charging Data Request [Initial] to the CHF for authorization for the subscriber to start the MBS session which is triggered by the start of MBS session.

13ch-b. The CHF opens the CDR for this MBS session.

13ch-c. The CHF acknowledges by sending Charging Data Response [Initial] to the MB-SMF.

Steps 14 to 22 per 3GPP TS 23.247 [9] Figure 7.1.1.2-1: MBS Session Creation without PCC.

5.2.2.2.3 MBS session deletion

The following figure 5.2.2.2.3-1 describes charging procedures for MBS session deletion, based on TS 23.247 [9] figures 7.1.1.4-1 and 7.1.1.5-1.

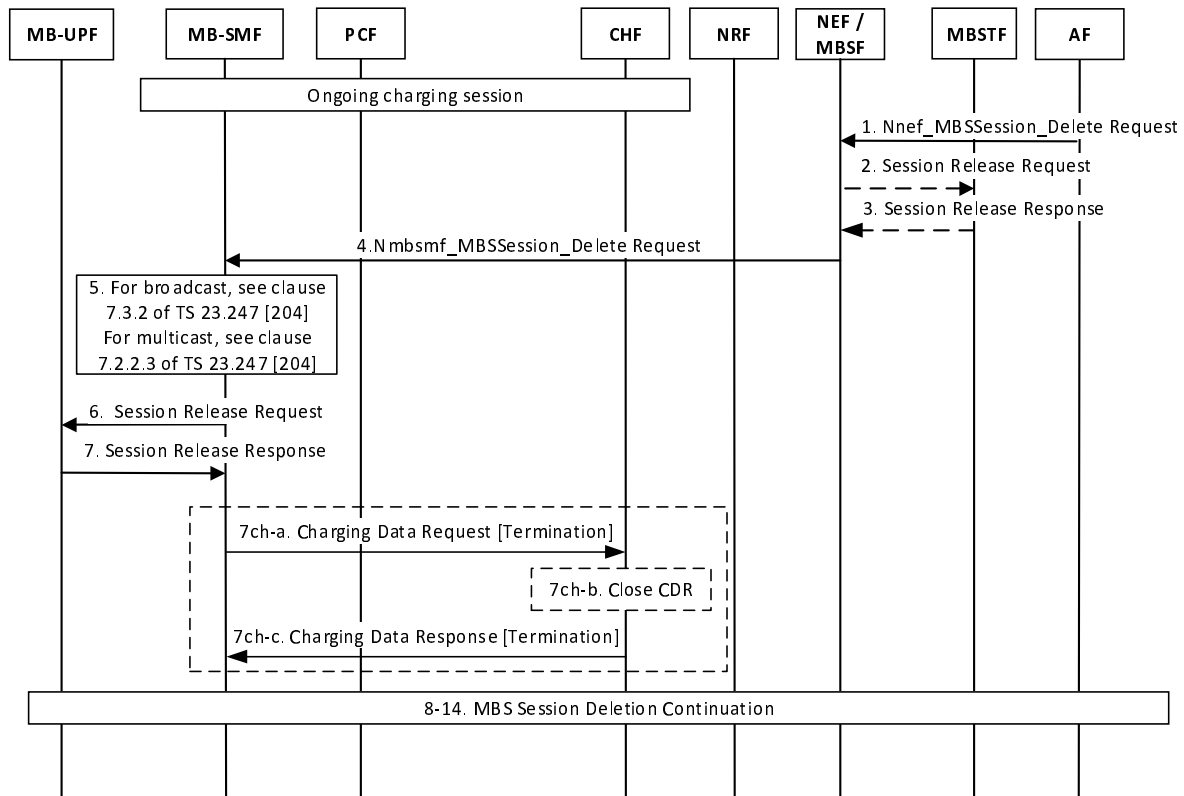

Figure 5.2.2.2.3-1: MBS session deletion

Steps 1 to 7 per 3GPP TS 23.247 [9] Figure 7.1.1.4-1: MBS Session Deletion without PCC.

7ch-a. The MB-SMF sends Charging Data Request [Termination] to the CHF, for terminating the charging associated with MBS session, with the trigger "End of MBS session".

7ch-b. The CHF closes the CDR for MBS session.

7ch-c. The CHF acknowledges by sending Charging Data Response [Termination] to the MB-SMF.

Steps 8 to 14 per 3GPP TS 23.247 [9] Figure 7.1.1.4-1: MBS Session Deletion without PCC.

5.2.2.2.4 MBS session establishment for broadcast

The following figure 5.2.2.2.4-1 describes the charging procedure for MBS session establishment for broadcast, based on TS 23.247 [9] figure 7.3.1-1.

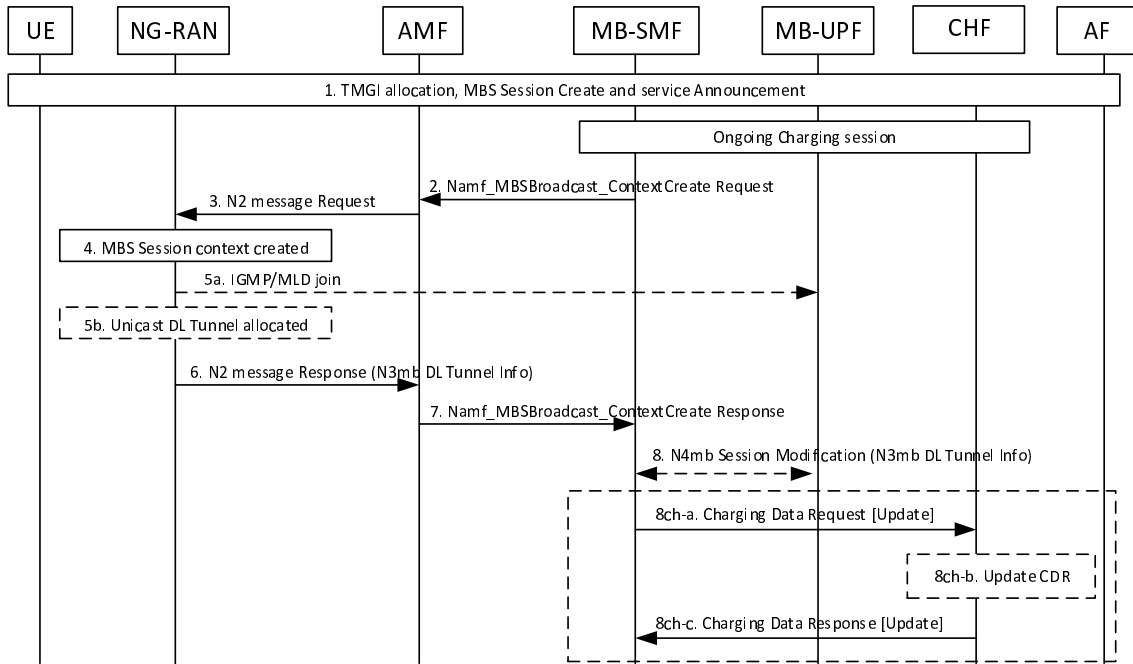

Figure 5.2.2.2.4-1: MBS session establishment for broadcast

Steps 1 to 8 per 3GPP TS 23.247 [9] Figure 7.3.1-1: MBS Session Establishment for Broadcast.

8ch-a. The MB-SMF sends Charging Data Request [Update] to the CHF triggered by the connection established with NG-RAN.

8ch-b. The CHF updates the CDR.

8ch-c. The CHF acknowledges by sending Charging Data Response [Update] to the MB-SMF.

5.2.2.2.5 Establishment of shared delivery towards RAN node for multicast

The following figure 5.2.2.2.5-1 describes multicast MBS session charging procedures for establishment of shared delivery towards RAN node, which occurs when the first UE is included in the context of the MBS session in the NG-RAN, or when handover to the target NG-RAN when the shared delivery tunnel has not yet been established in the target RAN node for this multicast MBS session, based on clause 7.2.1.4 of TS 23.247 [9].

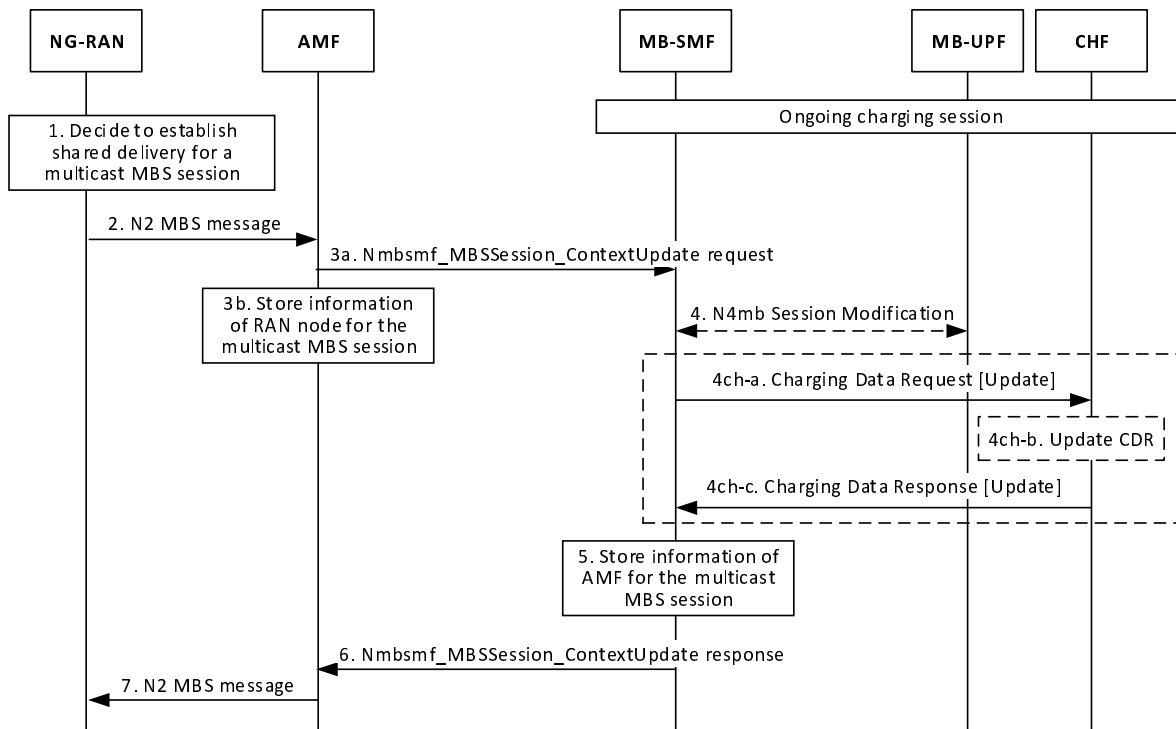

Figure 5.2.2.5-1: Establishment of shared delivery towards RAN node

Steps 1 to 4 per 3GPP TS 23.247 [9] Figure 7.2.1.4-1: Establishment of shared delivery toward NG-RAN node.

4ch-a. The MB-SMF sends Charging Data Request [Update] to the CHF when the corresponding trigger is armed.

4ch-b. The CHF updates the CDR.

4ch-c. The CHF acknowledges by sending Charging Data Response [Update] to the MB-SMF.

Steps 5 to 7 per 3GPP TS 23.247 [9] Figure 7.2.1.4-1: Establishment of shared delivery toward NG-RAN node.

5.2.2.2.6 Establishment of individual delivery towards UPF for multicast

The following figure 5.2.2.2.6-1 describes multicast MBS session charging procedures for establishment of individual delivery towards UPF, based on steps 11a-11e of TS 23.247 [9] figure 7.2.1.3-1, which occurs when the related NG-RAN does not support MBS and a tunnel between the UPF (PSA) and MB-UPF for 5GC individual MBS traffic delivery has not yet been established by the SMF for the multicast MBS session.

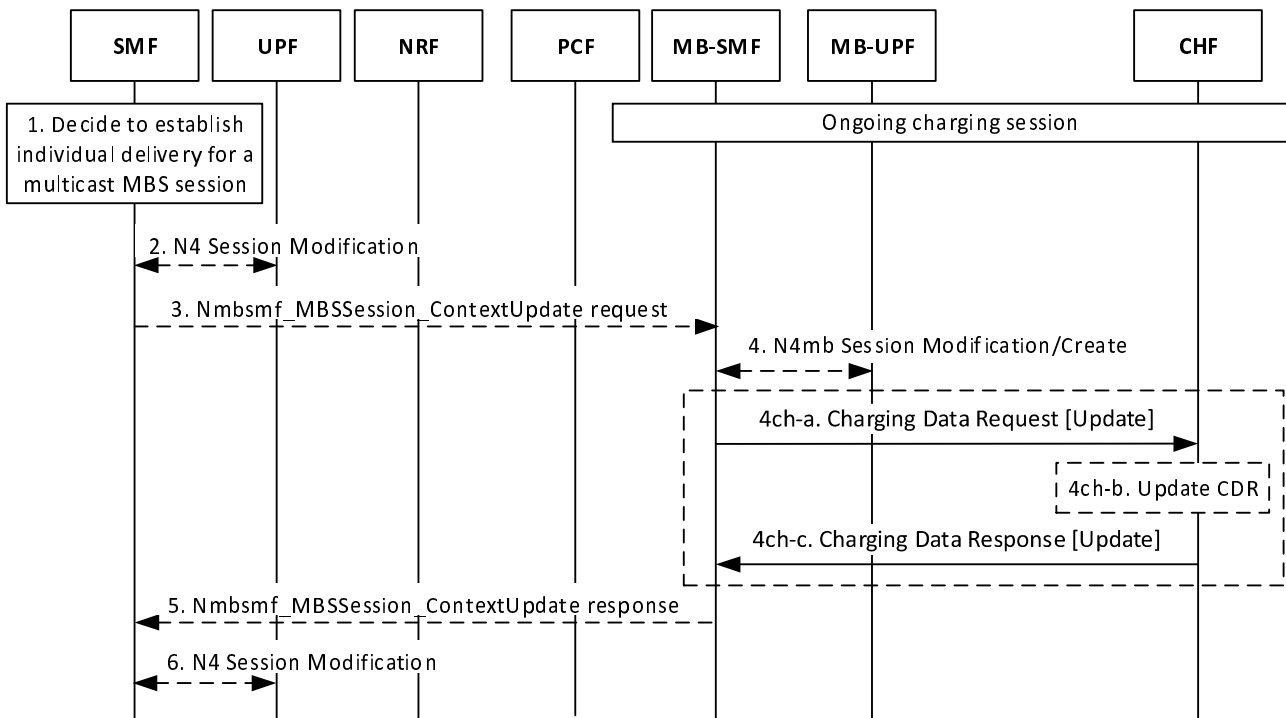

Figure 5.2.2.6-1: Establishment of individual delivery towards UPF

1. SMF decides to establish individual delivery for a multicast MBS session.

Steps 2 to 4 per 3GPP TS 23.247 [9] Figure 7.2.1.3-1: PDU Session modification for UE joining Multicast MBS session steps 11a to 11c.

4ch-a. The MB-SMF sends Charging Data Request [Update] to the CHF when the corresponding trigger is armed.

4ch-b. The CHF updates the CDR.

4ch-c. The CHF acknowledges by sending Charging Data Response [Update] to the MB-SMF.

Steps 5 to 6 per 3GPP TS 23.247 [9] Figure 7.2.1.3-1: PDU Session modification for UE joining Multicast MBS session steps 11d to 11e.

5.2.2.2.7 MBS session release for multicast

The following figure 5.2.2.2.7-1 describes the procedure when the shared delivery is released between NG-RAN and MB-UPF when the last UE leaves the multicast MBS session in the NG-RAN node. This figure is based on TS 23.247 [9] figure 7.2.2.4-1.

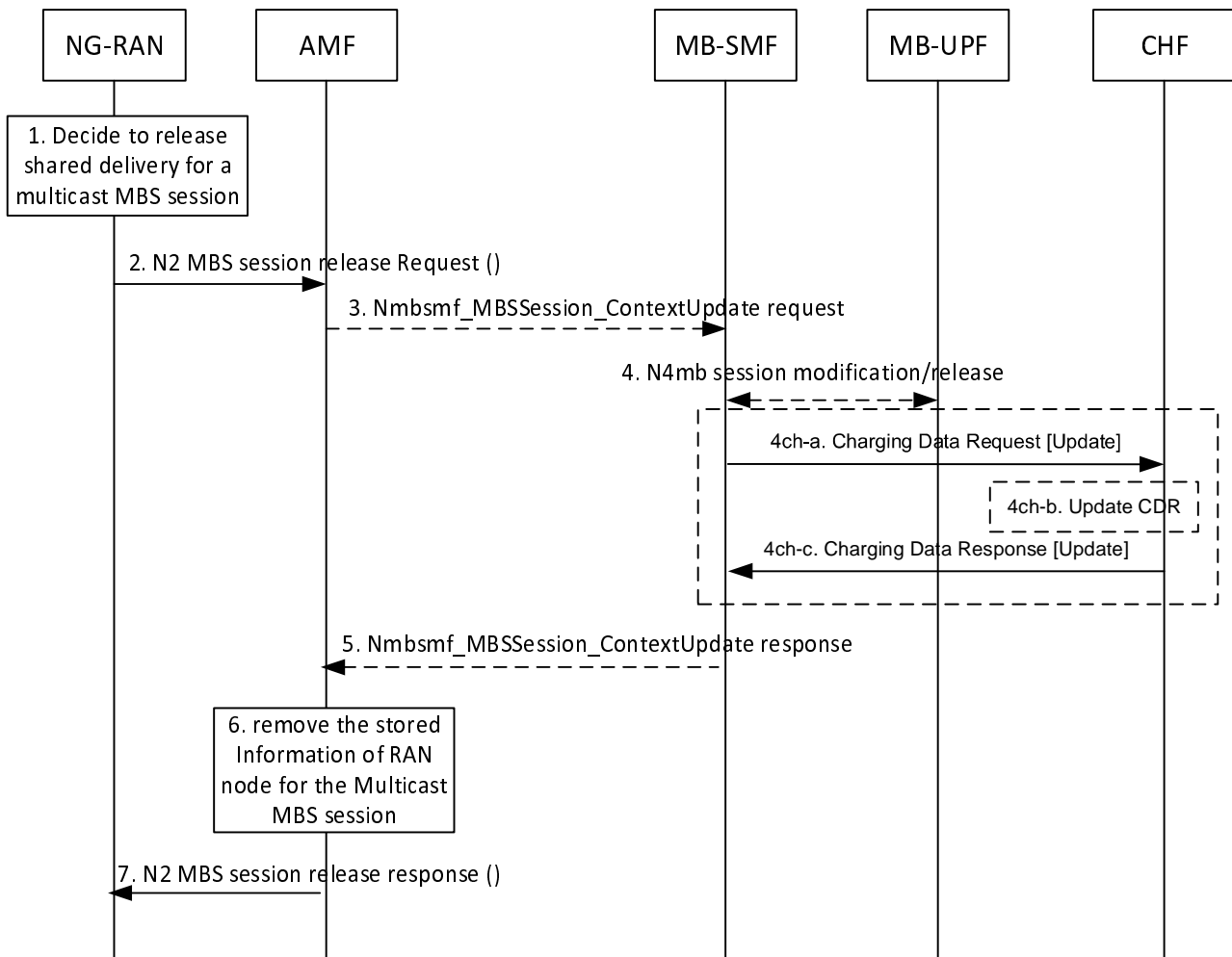

Figure 5.2.2.2.7-1: MBS session release for multicast

Steps 1 to 4 per 3GPP TS 23.247 [9] Figure 7.2.2.4-1: Release of shared delivery toward RAN node.

4ch-a. The MB-SMF sends Charging Data Request [Update] to the CHF, when the corresponding trigger is activated.

4ch-b. The CHF updates the CDR.

4ch-c. The CHF acknowledges by sending Charging Data Response [Update] to the MB-SMF.

Steps 5 to 7 per 3GPP TS 23.247 [9] Figure 7.2.2.4-1: Release of shared delivery toward RAN node.

5.2.2.2.8 MBS session activation for multicast

The following figure 5.2.2.2.8-1 describes the charging procedure when there is an MBS Session activation procedure. The MBS Session Activation procedure is for multicast only and is used for activating the resource for MBS data at NG-RAN. The focus is to provide such information to CHF once the MBS Session state changes. This figure is based on TS 23.247 [9] figure 7.2.5.2-1.

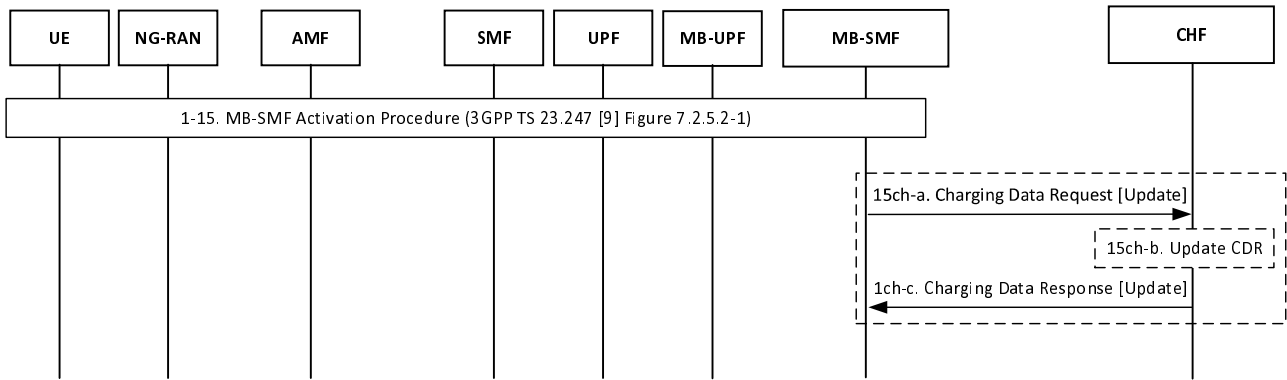

Figure 5.2.2.2.8-1: MBS session activation Charging Procedure

Steps 1 to 15 per 3GPP TS 23.247 [9] Figure 7.2.5.2-1: MBS Session Activation Procedure.

15ch-a. The MB-SMF sends Charging Data Request [Update] to the CHF when the corresponding trigger is armed.

15ch-b. The CHF updates the CDR.

15ch-c. The CHF acknowledges by sending Charging Data Response [Update] to the MB-SMF.

5.2.2.2.9 MBS session deactivation for multicast

The following figure 5.2.2.2.9-1 describes the charging procedure when there is an MBS Session Deactivation procedure. The MBS Session Deactivation procedure is for multicast only and is used for deactivating the resources for MBS data at from NG-RAN. The focus is to provide such information to CHF once the MBS Session state changes. This figure is based on TS 23.247 [9] figure 7.2.5.3-1.

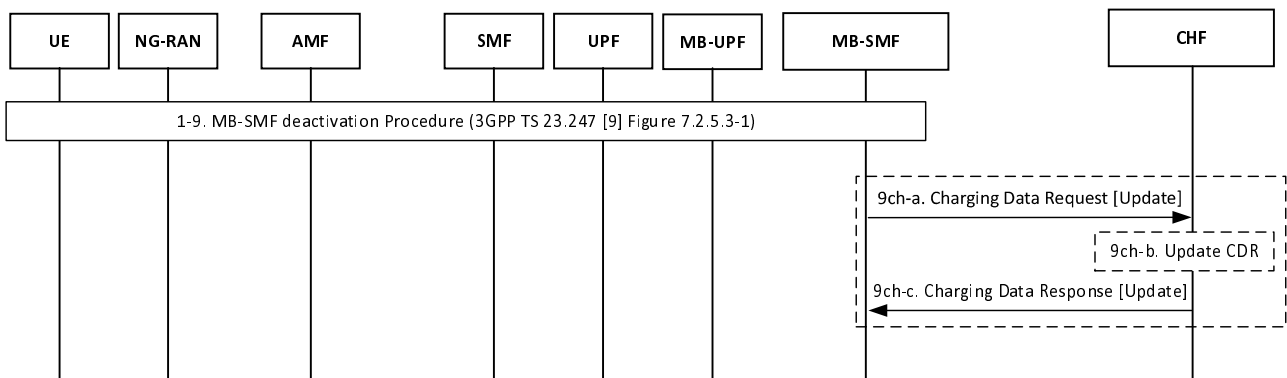

Figure 5.2.2.2.9-1: MBS session deactivation Charging Procedure

Steps 1 to 9 per 3GPP TS 23.247 [9] Figure 7.2.5.3-1: MBS Session Deactivation Procedure.

9ch-a. The MB-SMF sends Charging Data Request [Update] to the CHF when the corresponding trigger is activated.

9ch-b. The CHF updates the CDR.

9ch-c. The CHF acknowledges by sending Charging Data Response [Update] to the MB-SMF.

5.2.2.2.10 MBS Session Update Charging Procedure

The following figure 5.2.2.2.10-1 describes the charging procedure when there is a Multicast MBS Session Update procedure. Multicast MBS session update procedure is invoked by the AF to update the service requirement (result in multicast QoS parameters update and/or multicast QoS flow addition/removal) and/or MBS Service Area for an ongoing Multicast MBS session. The focus is to provide such information to CHF once the MBS Session state changes. This figure is based on TS 23.247 [9] figure 7.2.6-1.

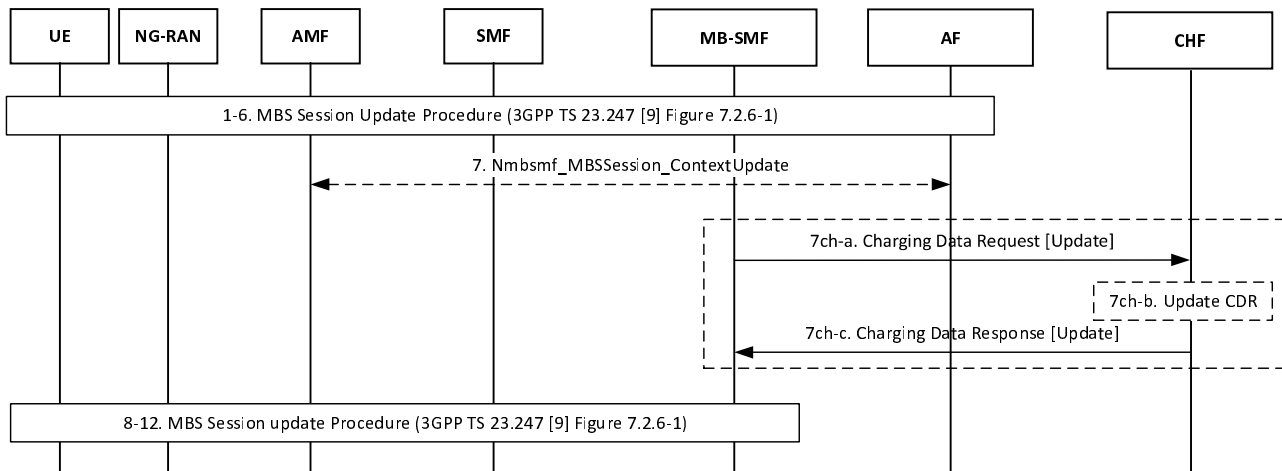

Figure 5.2.2.2.10-1: MBS Session update Charging Procedure

Steps 1 to 6 per 3GPP TS 23.247 [9] Figure 7.2.6-1: Multicast MBS Session update Procedure,

7. The AMF invokes the `Nmbmsf_MBSSession_ContextUpdate()` to the MB-SMF.

7ch-a. The MB-SMF sends Charging Data Request [Update] to the CHF when the corresponding trigger is activated.

7ch-b. The CHF updates the CDR.

7ch-c. The CHF acknowledges by sending Charging Data Response [Update] to the MB-SMF.

Steps 8 to 12 per 3GPP TS 23.247 [9] Figure 7.2.6-1: Multicast MBS Session update Procedure.

5.2.3 CDR generation

5.2.3.1 Introduction

The CHF CDRs for MBS session charging are generated by the CHF to collect charging information that they subsequently transfer to the Charging Gateway Function (CGF).

The following clauses describe in detail the conditions for opening, adding information to, and closing the CHF CDR.

5.2.3.2 Triggers for CHF CDR

5.2.3.2.1 General

A MBS session charging CHF CDR is used to collect charging information related to the MBS session data information from a single data source (e.g. Application Service Provider).

A CHF CDR shall be opened when the CHF receives Charging Data Request[Initial].

As an alternative to the default CHF behaviour, the "Individual Partial record" mechanism can be used based on Operator's policy configured in the CHF. In this case a new CDR shall be opened for each Charging Data Request[Initial, Update, Termination], charging information shall be added and the CDR shall then be closed. The Sequence Number will be incremented for each Charging Data Request[Initial, Update, Termination] received by the CHF.

5.2.3.2.2 Triggers for CHF CDR charging information addition

When the CHF receives Charging Data Request[Update], with the change conditions identified in Table 5.2.3.2.2-1 the charging information shall be added in the MBS session charging CHF CDR, and the CDR shall remain open, as the default supported mechanism.

Table 5.2.3.2.2-1: Triggers for CHF CDR charging information addition

Trigger Conditions
Change of Charging conditions
Connection established with NG-RAN
Connection released with NG-RAN
Connection established with UPF
Connection released with UPF
Quota management triggers
Time threshold reached
Time quota exhausted

In case the "Individual Partial record" mechanism is enabled, the Table 5.2.3.2.2-1 is not applicable. The charging information consists of a set of containers, which are added as "List of Multiple Unit Usage" parameter of the CHF CDR.

5.2.3.2.3 Triggers for CHF CDR partial record closure

When the CHF receives Charging Data Request [Update], with the change conditions identified in Table 5.2.3.2.3-1, the charging information shall be added in the MBS session charging CHF CDR, before the CDR is closed and a subsequent CHF CDR shall be opened with an incremented Sequence Number, as the default supported mechanism.

Table 5.2.3.2.3-1: Triggers for CHF CDR partial record closure

Trigger Conditions
Change of Charging conditions
MBS Session activity status change to active
MBS Session activity status change to inactive
Limit per MBS session
Expiry of data time limit per MBS session
Expiry of data volume limit per MBS session
Expiry of limit of number of charging condition changes

In case the "Individual Partial record" mechanism is enabled, the Table 5.2.3.2.3-1 is not applicable.

5.2.3.2.4 Triggers for CHF CDR closure

For MBS session charging, when the CHF receives Charging Data Request[Termination], the charging information shall be added in the MBS session charging CHF CDR and the CDR shall be closed.

5.2.4 Ga record transfer flows

Details of the Ga protocol application are specified in TS 32.295 [6].

5.2.5 Bmbs CDR file transfer

Details of the Bmbs protocol application are specified in TS 32.297 [7].

6 Definition of charging information

6.1 Data description for 5G MBS Session charging

6.1.1 Message contents

6.1.1.1 General

The Charging Data Request and Charging Data Response are specified in TS 32.290 [4] and include charging information. The Charging Data Request can be of type [Initial, Update, Termination].

Table 6.1.1.1-1 describes the use of these messages for converged charging.

Table 6.1.1.1-1: Converged charging messages reference table

Message	Source	Destination
Charging Data Request	MB-SMF	CHF
Charging Data Response	CHF	MB-SMF

The following clauses describe the different fields used in the Charging Data messages and the category in the tables is used according to the charging data configuration defined in clause 5.4 of TS 32.240 [2].

6.1.1.2 Charging Data Request message

Table 6.1.1.2-1 illustrates the basic structure of a Charging Data Request message from the MB-SMF as used for 5G MBS session converged charging.

Table 6.1.1.2-1: Charging Data Request message contents

Information Element	Converged Charging Category	Description
Session Identifier	O _C	Described in TS 32.290 [4]
Tenant Identifier	O _C	Described in TS 32.290 [4], and can hold the identifier of the AF application identifier.
NF Consumer Identification	M	Described in TS 32.290 [4]
NF Functionality	M	Described in TS 32.290 [4]
NF Name	O _C	Described in TS 32.290 [4]
NF Address	O _C	Described in TS 32.290 [4]
NF PLMN ID	O _C	Described in TS 32.290 [4]
Charging Identifier	O _M	Described in TS 32.290 [4]
Invocation Timestamp	M	Described in TS 32.290 [4]
Invocation Sequence Number	M	Described in TS 32.290 [4]
Retransmission Indicator	O _C	Described in TS 32.290 [4]
Notify URI	O _C	Described in TS 32.290 [4]
Supported Features	O _C	Described in TS 32.290 [4]
Service Specification Information	O _C	Described in TS 32.290 [4]
Multiple Unit Usage	O _C	Described in TS 32.290 [4]
Rating Group	M	Described in TS 32.290 [4]
Requested Unit	O _C	Described in TS 32.290 [4]
Time	O _C	Described in TS 32.290 [4]
Used Unit Container	O _C	Described in TS 32.290 [4]
Quota management Indicator	O _C	Described in TS 32.290 [4]
Triggers	O _C	This field is described in TS 32.290 [4] and holds the MBS session specific triggers described in clause 5.2.1.
Trigger Timestamp	O _C	Described in TS 32.290 [4]
Time	O _C	Described in TS 32.290 [4]
Downlink Volume	O _C	Described in TS 32.290 [4]
Local Sequence Number	O _M	Described in TS 32.290 [4]
MBS Container Information	O _C	This field holds the MBS session container specific information described in clause 6.2.1.3.
MB-UPF ID	O _C	This field holds the MB-UPF identifier used to identify the MB-UPF. This field shall only be included when used units are reported per MB-UPF.
MBS Session Charging Information	O _M	This field holds the MBS session specific information described in clause 6.2.1.2.

6.1.1.3 Charging data response message

Table 6.1.1.3-1 illustrates the basic structure of a Charging Data Response message from the CHF to MB-SMF as used for 5G MBS session converged charging.

Table 6.1.1.3-1: Charging Data Response message contents

Information Element	Converged Charging Category	Description
Session Identifier	O _C	Described in TS 32.290 [4]
Invocation Timestamp	M	Described in TS 32.290 [4]
Invocation Result	O _C	Described in TS 32.290 [4]
Invocation Result Code	O _C	Described in TS 32.290 [4]
Failed Parameter	O _C	Described in TS 32.290 [4]
Failure Handling	O _C	Described in TS 32.290 [4]
Invocation Sequence Number	M	Described in TS 32.290 [4]
Supported Features	O _C	Described in TS 32.290 [4]
Triggers	O _C	This field is described in TS 32.290 [4] and holds the MBS session specific triggers described in clause 5.2.1.
Multiple Unit Information	O _C	Described in TS 32.290 [4]
Result Code	O _C	Described in TS 32.290 [4]
Rating Group	O _M	Described in TS 32.290 [4]
Granted Unit	O _C	Described in TS 32.290 [4]
Time	O _C	Described in TS 32.290 [4]
Validity Time	O _C	Described in TS 32.290 [4]
Final Unit Indication	O _C	Described in TS 32.290 [4]
Time Quota Threshold	O _C	Described in TS 32.290 [4]
Quota Holding Time	O _C	Described in TS 32.290 [4]

6.1.2 Ga message contents

See clause 5.2.4.

6.1.3 CDR description on the B_{mbs} interface

6.1.3.1 General

This clause describes the CDR content and format generated for 5G MBS session charging.

The following tables provide a brief description of each CDR parameter. The category in the tables is used according to the charging data configuration defined in clause 5.4 of TS 32.240 [2]. Full definitions of the CDR parameters, sorted by the name in alphabetical order, are provided in TS 32.298 [8].

6.1.3.2 MBS session charging CHF CDR data

If enabled, CHF CDRs for MBS session charging shall be produced for each MBS session.

The fields of MBS session charging CHF CDR are specified in table 6.1.3.2-1.

Table 6.1.3.2-1: MBS session charging CHF record data

Field	Category	Description
Record Type	M	CHF record.
Recording Network Function ID	O _M	This field holds the name of the recording entity, i.e. the CHF id.
NF Consumer Information	M	This field holds the information of the MB-SMF that used the charging service.
NF Functionality	M	This field contains the function of the node (i.e. MB-SMF)
NF Name	O _C	This field holds the name of the MB-SMF used.
NF Address	O _C	This field holds the IP Address of the MB-SMF used.
NF PLMN ID	O _C	This field holds the PLMN identifier (MCC MNC) of the MB-SMF.
List of Multiple Unit Usage	O _M	This field holds a list of changes in charging conditions for all service data flows within this MBS session.
Rating Group	O _M	This field holds the rating group.
Used Unit Container	O _C	This field holds the used units and information connected to the reported units.
Triggers	O _C	This field holds the reason for closing the used unit container.
Trigger Timestamp	O _C	This field holds the timestamp of the trigger.
Time	O _C	This field holds the amount of used time.
Downlink Volume	O _C	This field holds the amount of used volume in downlink direction.
Rating Indicator	O _C	This field indicates if the units have been rated or not.
Local Sequence Number	M	This field holds the container sequence number.
MBS Container Information	O _C	This field holds the 5G MBS session specific information defined in clause 6.2.1.3.
MB-UPF ID	O _C	This field holds the MB-UPF identifier used to identify the MB-UPF when reporting the usage for the MB-UPF.
Record Opening Time	M	Described in TS 32.298 [8]
Duration	M	Described in TS 32.298 [8]
Record Sequence Number	C	Described in TS 32.298 [8]
Cause for Record Closing	M	Described in TS 32.298 [8]
Diagnostics	O _M	Described in TS 32.298 [8]
Local Record Sequence Number	O _M	Described in TS 32.298 [8]
Record Extensions	O _C	Described in TS 32.298 [8]
MBS Session Charging Information	O _M	This field holds the 5G MBS session specific information defined in clause 6.2.1.2.

6.2 5G MBS Session charging specific parameters

6.2.1 Definition of 5G MBS Session charging information

6.2.1.1 General

The Charging Information parameter used for 5G MBS session charging is provided in the following clauses.

6.2.1.2 Definition of MBS session charging information

MBS specific charging information used for 5G data connectivity charging is provided within the MBS Session Charging Information.

The detailed structure of the MBS Session Charging Information can be found in table 6.2.1.2-1.

Table 6.2.1.2-1: Structure of MBS Session Charging Information

Information Element	Category	Description
MBS Session ID	M	This field holds identifier of MBS session.
MBS Service Type	M	This field holds the type of the MBS session.
MBS Service Area	O _c	This field holds MBS Service Area served by the MBS session.
MBS Session Start Time	O _c	This field holds the timestamp when MBS session starts.
MBS Session Stop Time	O _c	This field holds the timestamp when MBS session terminates.
MBS Session Activity Status	O _c	This field holds the session activity status (active or inactive). May be provided if the "serviceType" attribute indicates a multicast MBS session.
Serving Network Function ID	O _c	This field holds the identity of the serving network function. It may have multiple occurrences.
Serving Network Function Information	M	This field holds the information of the serving network function: - AMF for the MBS sessions being served by MB-SMF in non-roaming
AMF Identifier	O _c	This field holds the AMF identifier.

6.2.1.3 Definition of MBS container information

Used Unit Container, described in table 6.2.1.3-1, specific charging information used for 5G data connectivity charging is provided within the MBS Container Information described in table 6.2.1.3-1.

Table 6.2.1.3-1: Structure of MBS Container Information

Information Element	Category	Description
Time of First Usage	O _c	This field holds the Timestamp when the first transmitted data packet of the MBS container.
Time of Last Usage	O _c	This field holds the Timestamp when the last transmitted data packet of the MBS container.
QoS Information	O _c	This field holds the QoS applied during the MBS container interval.
Established Connection Information	O _c	This field holds a list of NG-RAN nodes establishing connection, or a list of UPFs establishing connection with MB-UPF.

6.2.2 Detailed message format for converged charging

The following clause specifies per Operation Type the charging data that are sent by MB-SMF for 5G data connectivity converged charging.

The Operation Types are listed in the following order: I (Initial)/U (Update)/T (Termination)/E (Event). Therefore, when all Operation Types are possible it is marked as IUTE. If only some Operation Types are allowed for a node, only the appropriate letters are used (i.e. IUT or E) as indicated in the table heading. The omission of an Operation Type for a particular field is marked with "-" (i.e. IU-E). Also, when an entire field is not allowed in a node the entire cell is marked as "-".

Table 6.2.2-1 defines the basic structure of the supported fields in the Charging Data Request message for 5G MBS session converged charging in MB-SMF.

Table 6.2.2-1: Supported fields in *Charging Data Request* message

Information Element	Functionality of MB-SMF	MBS session charging
	Supported Operation Types	I/U/T/E
Session Identifier		-UT-
Tenant Identifier		IUT-
NF Consumer Identification		IUT-
NF Functionality		IUT-
NF Name		IUT-
NF Address		IUT-
NF PLMN ID		IUT-
Charging Identifier		IUT-
Invocation Timestamp		IUT-
Invocation Sequence Number		IUT-
Retransmission Indicator		IUT-
Notify URI		IUT-
Supported Features		IUT-
Service Specification Information		IUT-
Multiple Unit Usage		IUT-
Rating Group		IUT-
Requested Unit		IU--
Time		IU--
Used Unit Container		-UT-
Quota management Indicator		-UT-
Triggers		-UT-
Trigger Timestamp		-UT-
Time		-UT-
Downlink Volume		-UT-
Local Sequence Number		-UT-
MBS Container Information		-UT-
MB-UPF ID		IUT-
MBS Session Charging Information		IUT-
MBS Service Type		IUT-
MBS Service Area		IUT-
MBS Session Start Time		I--
MBS Session Stop Time		--T-
MBS Session Activity Status		-UT-
Serving Network Function ID		IUT-

Table 6.2.2-2 defines the basic structure of the supported fields in the *Charging Data* Response message for 5G MBS session converged charging in MB-SMF.

Table 6.2.2-2: Supported fields in *Charging Data Response* message

Information Element	Functionality of MB-SMF	MBS session charging
	Supported Operation Types	I/U/T/E
Session Identifier		I---
Invocation Timestamp		IUT-
Invocation Result		IUT-
Invocation Result Code		IUT-
Failed Parameter		IUT-
Failure Handling		IUT-
Invocation Sequence Number		IUT-
Supported Features		IU--
Triggers		IU--
Multiple Unit Information		IU--
Result Code		IU--
Rating Group		IU--
Granted Unit		IU--
Time		IU--
Validity Time		IU--
Final Unit Indication		IU--
Time Quota Threshold		IU--
Quota Holding Time		IU--

6.2.3 Formal 5G MBS Session charging parameter description

6.2.3.1 5G MBS Session CHF CDR parameters

The detailed definitions, abstract syntax and encoding of the MBS session charging CHF CDRs parameters are specified in TS 32.298 [8].

6.2.3.2 5G MBS Session resources attributes

The detailed definitions of resources attributes used for 5G MBS session charging are specified in TS 32.291 [5].

6.3 Bindings for 5G MBS Session charging

The mapping between the Information Elements, resource attributes and CHF CDR parameters for 5G MBS session charging is described in clause 7 of TS 32.291 [5].

Annex A (informative): Change history

Change history							
Date	Meeting	TDoc	CR	Rev	Cat	Subject/Comment	New version
2023-10	SA5#151	S5-237033				Initial skeleton	0.0.0
2023-10	SA5#151	S5-236913				Add CHF selection mechanism for MB-SMF	0.1.0
		S5-236915				Add 5MBS CDR generation requirements	
		S5-236916				Add 5G MBS charging information definition	
		S5-236917				MBS Tariff change trigger and charging event	
		S5-236918				Add reference point between MB-SMF and CHF and MBS charging ID	
		S5-236920				Add 5G MBS charging procedure for multicast and broadcast communication creation and deletion	
		S5-236921				Add 5G MBS charging procedure of broadcast session establishment	
		S5-236922				Add 5G MBS charging procedure of shared and individual delivery establishment for multicast	
2023-11	SA5#152	S5-238019				Rel-18 pCR 32.27x Add scope	0.2.0
		S5-238020				Rel-18 pCR 32.27x Add references	
		S5-238021				Rel-18 pCR 32.27x Add definitions of terms, symbols and abbreviations	
		S5-238022				Rel-18 pCR TR 32.27x MBS Charging Principles	
		S5-238023				Rel-18 pCR 32.27x Add general information for 5MBS charging	
		S5-238024				Rel-18 pCR 32.27x Add MBS session charging information	
		S5-238025				Rel-18 pCR 32.27x Add Bmbs interface information	
		S5-238026				Rel-18 pCR 32.27x Add Ga interface information	
2023-12	SA#102	SP-231529				Presented for information	1.0.0
2023-12	SA#102	SP-231749				TS number allocated at TSG SA#102 as 32.279	1.0.1
2024-02	SA5#153	S5-240407				Add bindings for 5G MBS Session charging	1.1.0
		S5-240512				Add MB-UPF ID in Charging Data Request and Response message from MB-SMF	
		S5-240733				MBS Session Release	
		S5-240734				MBS Session activation&deactivation&update procedure	
		S5-241021				MBS Session deactivation	
2024-03	SA#103	SP-240256				Presented to SA plenary for Approval	2.0.0
2024-03	SA#103					Upgrade to change control version	18.0.0
2024-06	SA#104	SP-240819	0001	2	F	Rel-18 CR TS 32.279 MBS Session Update	18.1.0
2024-06	SA#104	SP-240819	0002	1	F	Add charging identifier definition for MBS session charging	18.1.0
2024-06	SA#104	SP-240819	0003	2	F	Rel-18 CR TS 32.279 Correction on MBS session release, activation and deactivation	18.1.0
2024-06	SA#104	SP-240819	0006	1	F	Rel-18 CR 32.279 Correction MB-SMF requirements	18.1.0
2024-06	SA#104	SP-240819	0007	1	F	Rel-18 CR 32.279 Correcting use of MBS session	18.1.0
2024-06	SA#104	SP-240819	0008	3	F	Rel-18 CR 32.279 Correcting message contents for MB-SMF	18.1.0
2024-06	SA#104	SP-240819	0011	1	F	Correction on MBS Session Activity Status	18.1.0

History

Document history		
V18.0.0	May 2024	Publication
V18.1.0	July 2024	Publication