

# ETSI TS 132 342 V14.0.0 (2017-04)



**Digital cellular telecommunications system (Phase 2+) (GSM);  
Universal Mobile Telecommunications System (UMTS);  
LTE;  
Telecommunication management;  
File Transfer (FT) Integration Reference Point (IRP);  
Information Service (IS)  
(3GPP TS 32.342 version 14.0.0 Release 14)**



---

Reference

RTS/TSGS-0532342ve00

---

Keywords

GSM,LTE,UMTS

**ETSI**

650 Route des Lucioles  
F-06921 Sophia Antipolis Cedex - FRANCE

Tel.: +33 4 92 94 42 00 Fax: +33 4 93 65 47 16

Siret N° 348 623 562 00017 - NAF 742 C  
Association à but non lucratif enregistrée à la  
Sous-Préfecture de Grasse (06) N° 7803/88

---

**Important notice**

The present document can be downloaded from:

<http://www.etsi.org/standards-search>

The present document may be made available in electronic versions and/or in print. The content of any electronic and/or print versions of the present document shall not be modified without the prior written authorization of ETSI. In case of any existing or perceived difference in contents between such versions and/or in print, the only prevailing document is the print of the Portable Document Format (PDF) version kept on a specific network drive within ETSI Secretariat.

Users of the present document should be aware that the document may be subject to revision or change of status.

Information on the current status of this and other ETSI documents is available at

<https://portal.etsi.org/TB/ETSIDeliverableStatus.aspx>

If you find errors in the present document, please send your comment to one of the following services:

<https://portal.etsi.org/People/CommiteeSupportStaff.aspx>

---

**Copyright Notification**

No part may be reproduced or utilized in any form or by any means, electronic or mechanical, including photocopying and microfilm except as authorized by written permission of ETSI.

The content of the PDF version shall not be modified without the written authorization of ETSI.

The copyright and the foregoing restriction extend to reproduction in all media.

© European Telecommunications Standards Institute 2017.

All rights reserved.

DECT™, PLUGTESTS™, UMTS™ and the ETSI logo are Trade Marks of ETSI registered for the benefit of its Members.

3GPP™ and LTE™ are Trade Marks of ETSI registered for the benefit of its Members and of the 3GPP Organizational Partners.

oneM2M logo is protected for the benefit of its Members

GSM® and the GSM logo are Trade Marks registered and owned by the GSM Association.

---

## Intellectual Property Rights

IPRs essential or potentially essential to the present document may have been declared to ETSI. The information pertaining to these essential IPRs, if any, is publicly available for **ETSI members and non-members**, and can be found in ETSI SR 000 314: "*Intellectual Property Rights (IPRs); Essential, or potentially Essential, IPRs notified to ETSI in respect of ETSI standards*", which is available from the ETSI Secretariat. Latest updates are available on the ETSI Web server (<https://ipr.etsi.org>).

Pursuant to the ETSI IPR Policy, no investigation, including IPR searches, has been carried out by ETSI. No guarantee can be given as to the existence of other IPRs not referenced in ETSI SR 000 314 (or the updates on the ETSI Web server) which are, or may be, or may become, essential to the present document.

---

## Foreword

This Technical Specification (TS) has been produced by ETSI 3rd Generation Partnership Project (3GPP).

The present document may refer to technical specifications or reports using their 3GPP identities, UMTS identities or GSM identities. These should be interpreted as being references to the corresponding ETSI deliverables.

The cross reference between GSM, UMTS, 3GPP and ETSI identities can be found under <http://webapp.etsi.org/key/queryform.asp>.

---

## Modal verbs terminology

In the present document "**shall**", "**shall not**", "**should**", "**should not**", "**may**", "**need not**", "**will**", "**will not**", "**can**" and "**cannot**" are to be interpreted as described in clause 3.2 of the [ETSI Drafting Rules](#) (Verbal forms for the expression of provisions).

"**must**" and "**must not**" are **NOT** allowed in ETSI deliverables except when used in direct citation.

# Contents

Intellectual Property Rights .....	2
Foreword.....	2
Modal verbs terminology.....	2
Foreword.....	5
Introduction .....	5
1 Scope .....	6
2 References .....	6
3 Definitions and abbreviations.....	7
3.1 Definitions .....	7
3.2 Abbreviations .....	7
4 System Overview .....	8
4.1 System context .....	8
4.2 Compliance rules.....	8
5 Information Object Classes (IOC).....	9
5.1 Information entities imported and local labels .....	9
5.2 Class Diagram .....	9
5.2.1 Attributes and relationships .....	9
5.2.2 Inheritance .....	10
5.3 Information Object Class (IOC) definitions .....	11
5.3.1 FileTransferIRP .....	11
5.3.1.1 Definition .....	11
5.3.2 AvailableFileDescriptor.....	11
5.3.2.1 Definition .....	11
5.3.2.2 Attributes.....	11
5.3.3 AvailableFileList .....	11
5.3.3.1 Definition .....	11
5.3.4 File .....	11
5.3.4.1 Definition .....	11
5.4 Information relationship definitions .....	12
5.4.1 relation-ftIRP-availableFileList (M) .....	12
5.4.1.1 Definition .....	12
5.4.1.2 Role .....	12
5.4.2 relation-availableFileList-availableFiles (M).....	12
5.4.2.1 Definition .....	12
5.4.2.2 Role .....	12
5.4.2.3 Constraint.....	12
5.4.3 relation-availableFileDescriptor-file (M).....	12
5.4.3.1 Definition .....	12
5.4.3.2 Role .....	12
5.5 Information attribute definition .....	13
5.5.1 Definition and legal values .....	13
6 Interface Definition .....	14
6.1 Class diagram .....	14
6.2 Generic rules .....	14
6.3 FileTransferIRPOperations_1 Interface .....	15
6.3.1 Operation listAvailableFiles (M) .....	15
6.3.1.1 Definition .....	15
6.3.1.2 Input parameters.....	15
6.3.1.3 Output parameters .....	15
6.3.1.4 Pre-condition.....	15
6.3.1.5 Post-condition .....	15
6.3.1.6 Exceptions.....	16

6.4 FileTransferIRPOperations\_2 Interface ..... 16

6.4.1 Operation fileDownloadIndication (O)..... 16

6.4.1.1 Definition ..... 16

6.4.1.2 Input parameters ..... 16

6.4.1.3 Output parameters ..... 16

6.4.1.4 Pre-condition..... 16

6.4.1.5 Post-condition ..... 16

6.4.1.6 Exceptions ..... 16

6.5 FileTransferIRPNotifications\_1 Interface ..... 17

6.5.1 Notification notifyFileReady (M)..... 17

6.5.1.1 Definition ..... 17

6.5.1.2 Input Parameters ..... 17

6.5.1.3 Triggering Event ..... 17

6.5.1.3.1 From-state..... 17

6.5.1.3.2 To-state..... 17

6.5.2 Notification notifyFilePreparationError (M) ..... 18

6.5.2.1 Definition ..... 18

6.5.2.2 Input Parameters ..... 18

6.5.2.3 Triggering Event ..... 18

6.5.2.3.1 From-state..... 18

6.5.2.3.2 To-state..... 18

**Annex A (normative): File Naming Convention.....19**

**Annex B (informative): Change history .....20**

History .....21

---

# Foreword

This Technical Specification (TS) has been produced by the 3<sup>rd</sup> Generation Partnership Project (3GPP).

The contents of the present document are subject to continuing work within the TSG and may change following formal TSG approval. Should the TSG modify the contents of the present document, it will be re-released by the TSG with an identifying change of release date and an increase in version number as follows:

Version x.y.z

where:

- x the first digit:
  - 1 presented to TSG for information;
  - 2 presented to TSG for approval;
  - 3 or greater indicates TSG approved document under change control.
- y the second digit is incremented for all changes of substance, i.e. technical enhancements, corrections, updates, etc.
- z the third digit is incremented when editorial only changes have been incorporated in the document.

---

# Introduction

The present document is part of a TS-family covering the 3<sup>rd</sup> Generation Partnership Project; Technical Specification Group Services and System Aspects; Telecommunication management, as identified below:

32.341: "File Transfer (FT) Integration Reference Point (IRP): Requirements"

**32.342: "File Transfer (FT) Integration Reference Point (IRP): Information Service (IS)"**

32.346: "File Transfer (FT) Integration Reference Point (IRP); Solution Set (SS) definitions"

The present document is part of a TS-family which describe the requirements and information model necessary for the Telecommunication Management (TM) of 3G systems. The TM principles and TM architecture are specified in 3GPP TS 32.101 [1] and 3GPP TS 32.102 [2].

Network Elements (NEs) under management, element managers as well as network managers generate various management information stored in file format. This IRP is addressing how these files are exchanged through Itf-N as well as certain aspects of file management and maintenance. It is anticipated that all management functions (e.g. PM, Call Trace, CM) as well as associated IRPs making reuse of capabilities provided by this File Transfer IRP.

---

# 1 Scope

The present document specifies the Information Service for the File Transfer Integration Reference Point (FileTransferIRP) as it applies to the Itf-N.

The present document defines the semantics of operations (and their parameters) visible across the Itf-N in a protocol and technology neutral way. It does not define the syntax or encoding of the operations and their parameters.

---

# 2 References

The following documents contain provisions, which through reference in this text constitute provisions of the present document.

- References are either specific (identified by date of publication, edition number, version number, etc.) or non-specific.
- For a specific reference, subsequent revisions do not apply.
- For a non-specific reference, the latest version applies. In the case of a reference to a 3GPP document (including a GSM document), a non-specific reference implicitly refers to the latest version of that document in the same Release as the present document.

- [1] 3GPP TS 32.101: "Telecommunication management; Principles and high level requirements".
- [2] 3GPP TS 32.102: "Telecommunication management; Architecture".
- [3] 3GPP TS 32.111-2: "Telecommunication management; Fault management; Part 2: Alarm Integration Reference Point (IRP): Information Service (IS)".
- [4] 3GPP TS 32.302: "Telecommunication management; Configuration Management (CM); Notification Integration Reference Point (IRP): Information Service (IS)".
- [5] 3GPP TS 32.312: "Telecommunication management; Generic Integration Reference Point (IRP): Information Service (IS)".
- [6] 3GPP TS 32.321: "Telecommunication management; Test management Integration Reference Point (IRP): Requirements".  
3GPP TS 32.322: "Telecommunication management; Test management Integration Reference Point (IRP): Information Service (IS)".  
3GPP TS 32.323: "Telecommunication management; Test management Integration Reference Point (IRP): Common Object Request Broker Architecture (CORBA) Solution Set (SS)".  
3GPP TS 32.325: "Telecommunication management; Test management Integration Reference Point (IRP); eXtensible Markup Language (XML) definitions".
- [7] 3GPP TS 32.341: "Telecommunication management; File Transfer (FT) Integration Reference Point (IRP): Requirements".
- [8] 3GPP TS 32.411: "Telecommunication management; Performance Management (PM) Integration Reference Point (IRP): Requirements".  
3GPP TS 32.412: "Telecommunication management; Performance Management (PM) Integration Reference Point (IRP): Information Service (IS)".  
3GPP TS 32.413: "Telecommunication management; Performance Management (PM) Integration Reference Point (IRP): Common Object Request Broker Architecture (CORBA) Solution Set (SS)".  
3GPP TS 32.415: "Telecommunication management; Performance Management (PM) Integration Reference Point (IRP); eXtensible Markup Language (XML) definitions".

- [9] 3GPP TS 32.421: "Telecommunication Management; Subscriber and Equipment Trace: Trace Concepts and Requirements".
- [10] 3GPP TS 32.611: "Telecommunication management; Configuration Management (CM); Bulk CM Integration Reference Point (IRP): Requirements".
- 3GPP TS 32.612: "Telecommunication management; Configuration Management (CM); Bulk CM Integration Reference Point (IRP): Information Service (IS)".
- 3GPP TS 32.613: "Telecommunication management; Configuration Management (CM); Bulk CM Integration Reference Point (IRP): Common Object Request Broker Architecture (CORBA) Solution Set (SS)".
- 3GPP TS 32.615: "Telecommunication management; Configuration Management (CM); Bulk CM Integration Reference Point (IRP): eXtensible Markup Language (XML) file format definition".
- [11] 3GPP TS 32.331: "Telecommunication management; Notification Log (NL) Integration Reference Point (IRP): Requirements".
- 3GPP TS 32.332: "Telecommunication management; Notification Log (NL) Integration Reference Point (IRP): Information Service (IS)".
- 3GPP TS 32.333: "Telecommunication management; Notification Log (NL) Integration Reference Point (IRP): Common Object Request Broker Architecture (CORBA) Solution Set (SS)".
- 3GPP TS 32.335: "Telecommunication management; Notification Log (NL) Integration Reference Point (IRP): eXtensible Markup Language (XML) solution definitions".
- [12] 3GPP TS 32.622: "Telecommunication management; Configuration Management (CM); Generic network resources Integration Reference Point (IRP): Network Resource Model (NRM)".
- [13] 3GPP TS 32.240: "Telecommunication management; Charging management; Charging architecture and principles".
- [14] 3GPP TS 32.150: "Telecommunication management; Integration Reference Point (IRP) Concept and definitions".

---

## 3 Definitions and abbreviations

### 3.1 Definitions

For the purposes of the present document, the terms and definitions defined in 3GPP TS 32.101 [1], TS 32.102 [2] and TS 32.341 [7] apply.

### 3.2 Abbreviations

For the purposes of the present document, the following abbreviations apply:

CM	Configuration Management
EM	Element Manager
IOC	Information Object Class
IRP	Integration Reference Point
NE	Network Element
PM	Performance Management
UML	Unified Modelling Language



## 4 System Overview

### 4.1 System context

The general definition of the System Context for the present IRP is found in 3GPP TS 32.150 [14] subclause 4.7.

In addition, the set of related IRP(s) relevant to the present IRP is shown in the two diagrams below.

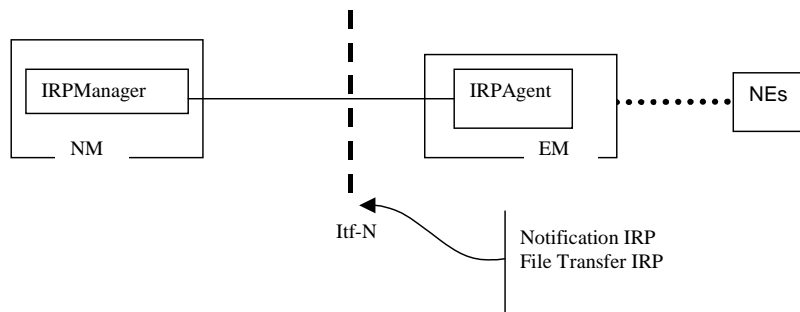

**Figure 4.1: System Context A**

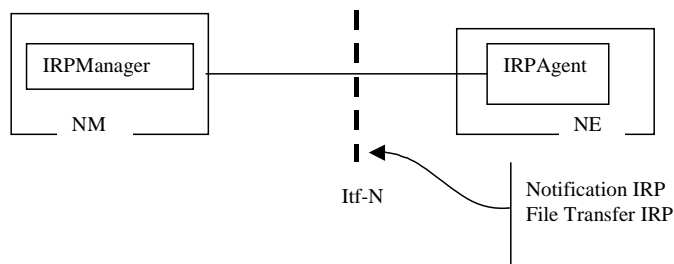

**Figure 4.2: System Context B**

### 4.2 Compliance rules

For general definitions of compliance rules related to qualifiers (Mandatory/Optional/Conditional) for *operations*, *notifications* and *parameters* (of operations and notifications) please refer to 3GPP TS 32.150 [14].

# 5 Information Object Classes (IOC)

## 5.1 Information entities imported and local labels

Label reference	Local label
3GPP TS 32.622 [12], information object class, Top	Top
3GPP TS 32.622 [12], information object class, IRPAgent	IRPAgent
3GPP TS 32.622 [12], information object class, GenericIRP	GenericIRP
3GPP TS 32.312 [5], information object class, ManagedGenericIRP	ManagedGenericIRP
3GPP TS 32.302 [4], information object class, NotificationIRP	NotificationIRP

## 5.2 Class Diagram

### 5.2.1 Attributes and relationships

This clause introduces the set of information object classes (IOCs) that encapsulate information within the IRPAgent. The intent is to identify the information required for the FileTransferIRP Agent implementation of its operations and notification emission. This clause provides the overview of all support object classes in UML. Subsequent clauses provide more detailed specification of various aspects of these support object classes.

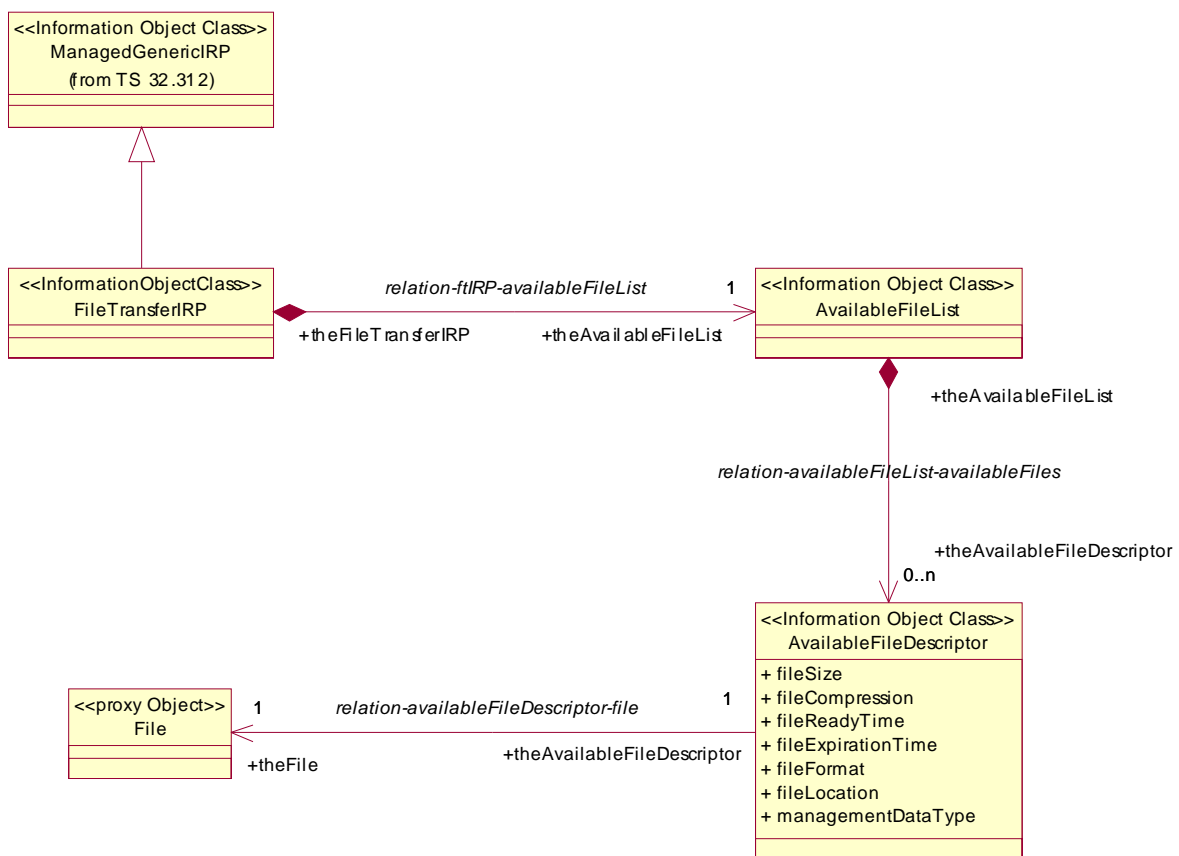

Figure 5.1: Information Object Class (IOC) UML Diagram

## 5.2.2 Inheritance

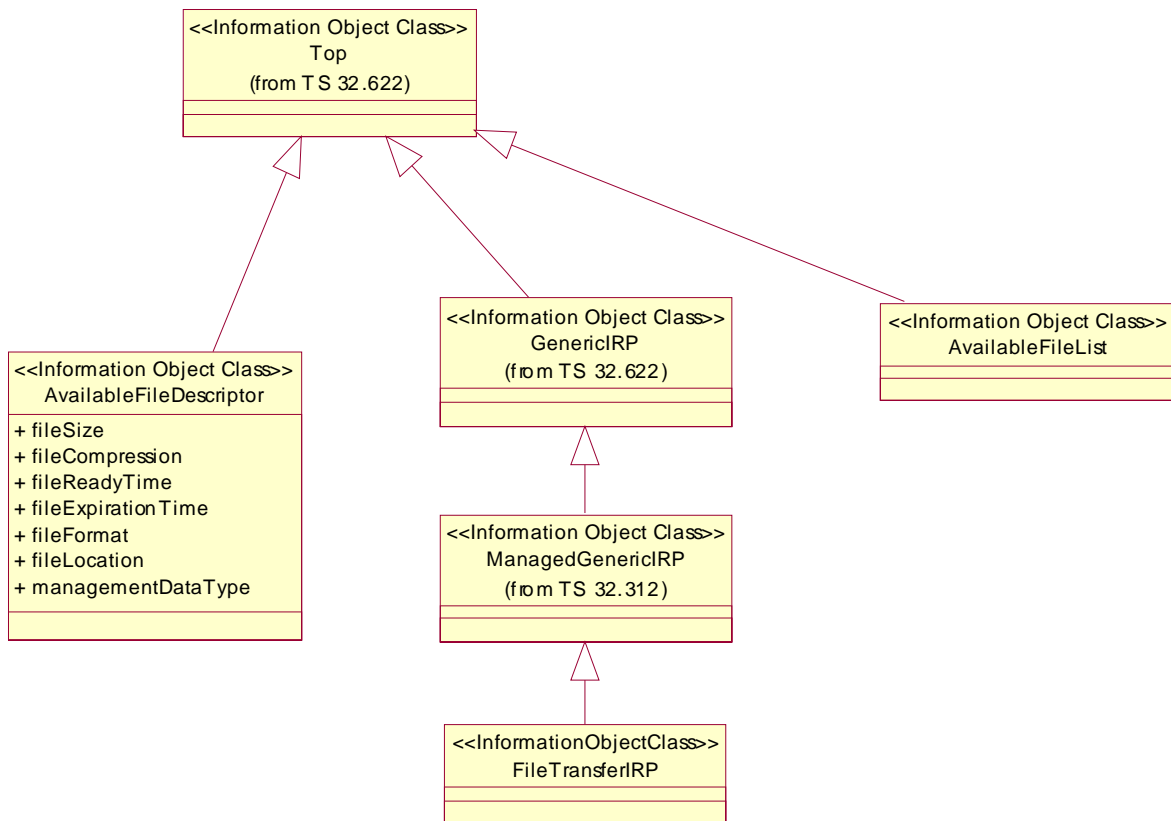

Figure 5.2: Information Object Class (IOC) Inheritance UML Diagram

## 5.3 Information Object Class (IOC) definitions

### 5.3.1 FileTransferIRP

#### 5.3.1.1 Definition

`FileTransferIRP` is the representation of the file transfer management capabilities specified by the present document. This IOC inherits from `ManagedGenericIRP` IOC specified in 3GPP TS 32.312 [5].

### 5.3.2 AvailableFileDescriptor

#### 5.3.2.1 Definition

`AvailableFileDescriptor` represents the information about an existing closed file containing management data (performance measurement data, etc.). The file is ready for retrieval by `IRPManagers`.

#### 5.3.2.2 Attributes

Attribute name	Visibility	Support Qualifier	Read Qualifier	Write Qualifier
<code>managementDataType</code>	+	M	M	-
<code>fileSize</code>	+	M	M	-
<code>fileCompression</code>	+	M	M	-
<code>fileReadyTime</code>	+	M	M	-
<code>fileExpirationTime</code>	+	M	M	-
<code>fileFormat</code>	+	M	M	-
<code>fileLocation</code>	+	M	M	-

### 5.3.3 AvailableFileList

#### 5.3.3.1 Definition

`AvailableFileList` is the representation of a list of files represented by individual `AvailableFileDescriptor(s)`.

### 5.3.4 File

#### 5.3.4.1 Definition

The Proxy Object File represents the file stored in the managed system.

## 5.4 Information relationship definitions

### 5.4.1 relation-ftIRP-availableFileList (M)

#### 5.4.1.1 Definition

This represents the relationship between `FileTransferIRP` and `AvailableFileList`.

#### 5.4.1.2 Role

Name	Definition
<code>theAvailableFileList</code>	It represents the <code>AvailableFileList</code> .
<code>theFileTransferIRP</code>	It represents the <code>FileTransferIRP</code> .

### 5.4.2 relation-availableFileList-availableFiles (M)

#### 5.4.2.1 Definition

This represents the relationship between `AvailableFileDescriptor` and `AvailableFileList`.

#### 5.4.2.2 Role

Name	Definition
<code>theAvailableFileDescriptor</code>	It represents the <code>AvailableFileDescriptor</code> .
<code>theAvailableFileList</code>	It represents the <code>AvailableFileList</code> .

#### 5.4.2.3 Constraint

Name	Definition
<code>uniqueFileLocation</code>	The <code>fileLocation</code> , playing the role of the file within the same <code>FileTransferIRP</code> , must be unique among all <code>AvailableFileDescriptors</code> .

### 5.4.3 relation-availableFileDescriptor-file (M)

#### 5.4.3.1 Definition

This represents the relationship between `AvailableFileDescriptor` and `PhysicalFile`.

#### 5.4.3.2 Role

Name	Definition
<code>theAvailableFileDescriptor</code>	It represents the <code>AvailableFileDescriptor</code> .
<code>theAvailableFile</code>	It represents the <code>PhysicalFile</code> .

## 5.5 Information attribute definition

### 5.5.1 Definition and legal values

Attribute Name	Definition	Legal Values
fileSize	It identifies the size of the file.	Its value is positive Integer (the unit is byte).
fileCompression	It identifies the name of the compression algorithm used for the file.	An empty fileCompression means that there is no compression on the file. Choice of compression algorithm is vendor-specific but is encouraged to use industrial standard algorithm such as GZIP.
fileReadyTime	It identifies the date and time when the file was last closed and made available for upload and the file content will not be changed	All values that indicate valid time.
fileExpirationTime	It identifies the date and time beyond which the file may be deleted.	All values that indicate valid time. It should be later than fileReadyTime. It shall not be empty.
fileFormat	It identifies the encoding technique used by the file.	Its value should indicate the IRPVersion of the file format specification plus to indicate if "ASN1" or "XML-schema" is used.
fileLocation	It identifies the location of the file described by AvailableFileDescriptor in the IRPAgent. The location may be a directory path or a URL.	<ul style="list-style-type: none"> <li>Any valid file directory path.</li> <li>Any valid URL.</li> </ul> E.g.: "\202.112.101.1\D:\user\performanceFiles\<xxx>" or " <a href="ftp://nms.telecom.org.com/datastore/&lt;xxx&gt;">ftp://nms.telecom.org.com/datastore/&lt;xxx&gt;</a> "  where <xxx> is the filename and the file naming convention is defined in Annex A File Naming Convention.
managementDataTypes	It identifies the type of the management data in the file.	"CG" for charging files (TS 32.240 [13]), "CM" for configuration files (except inventory) (Bulk CM IRP TS 32.61x [10]), "CT" for call trace files (Subscriber and Equipment Trace TS 32.421 [9]), "IM" for inventory files, "NL" for notification log files (Notification Log IRP TS 32.33x [11]), "OT" for other files, "PM" for performance data files (Performance Management IRP TS 32.41x [8]), "TE" for test files (Test Management IRP TS 32.32x [6]).

## 6 Interface Definition

### 6.1 Class diagram

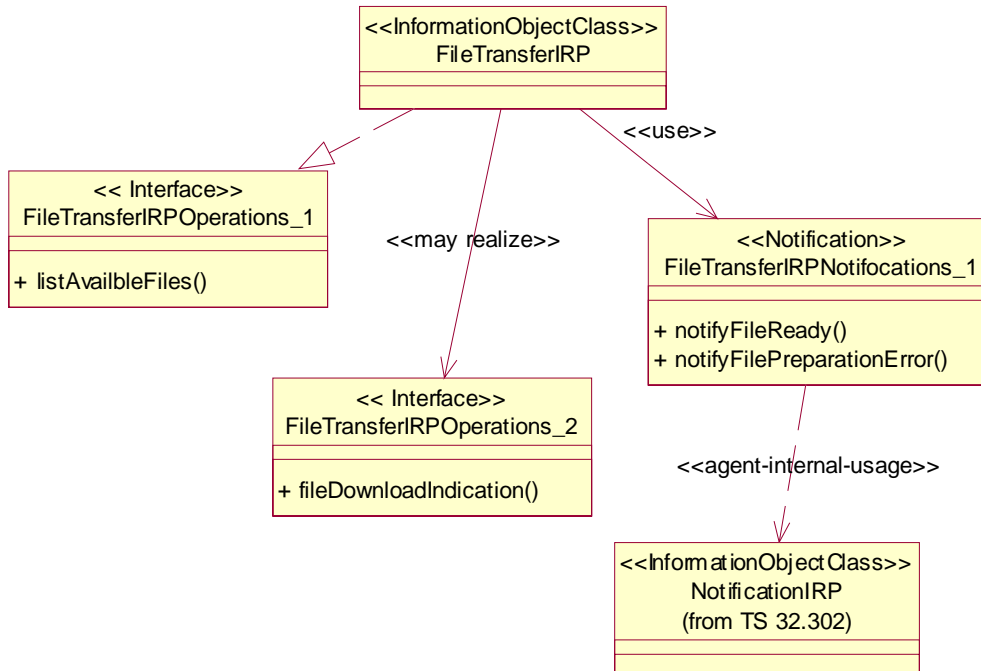

Figure 6.1: Class Diagram

### 6.2 Generic rules

- **Rule 1:** each operation with at least one input parameter supports a pre-condition `valid_input_parameter` which indicates that all input parameters shall be valid with regards to their information type. Additionally, each such operation supports an exception `operation_failed_invalid_input_parameter` which is raised when pre-condition `valid_input_parameter` is false. The exception has the same entry and exit state.
- **Rule 2:** each operation with at least one optional input parameter supports a set of pre-conditions `supported_optional_input_parameter_xxx` where "xxx" is the name of the optional input parameter and the pre-condition indicates that the operation supports the named optional input parameter. Additionally, each such operation supports an exception `operation_failed_unsupported_optional_input_parameter_xxx` which is raised when (a) the pre-condition `supported_optional_input_parameter_xxx` is false and (b) the named optional input parameter is carrying information. The exception has the same entry and exit state.
- **Rule 3:** each operation shall support a generic exception `operation_failed_internal_problem` which is raised when an internal problem occurs and that the operation cannot be completed. The exception has the same entry and exit state.

## 6.3 FileTransferIRPOperations\_1 Interface

### 6.3.1 Operation listAvailableFiles (M)

#### 6.3.1.1 Definition

This operation allows IRPManager to list all or specified available management data files stored in the IRPAgent.

A Solution Set may choose to split this operation in several operations (e.g. operations to get "iterator" which fulfil the criteria and other operations to retrieve the detailed information of the files from the "iterator").

#### 6.3.1.2 Input parameters

Parameter Name	Qualifier	Information type	Comment
managementDataType	M	AvailableFileDescriptor. managementDataType	It specifies the type of the management data stored in the file.
beginTime	M	The IRPManager wants a list of the available file(s) whose ready time(s) are later or equal to this time. This parameter is expressed in UTC time.	This parameter indicates date and time. If this parameter is empty, no beginTime-restriction should be applied on the ready time.
endTime	M	The IRPManager wants to list information about the available file(s) whose ready time(s) are earlier than this time. This parameter is expressed in UTC time.	This parameter indicates date and time. If this parameter is empty, no endTime-restriction should be applied on the ready time.

#### 6.3.1.3 Output parameters

Parameter Name	Qualifier	Matching Information	Comment
fileInfoList	M	LIST of STRUCT < AvailableFileDescriptor.fileLocation, AvailableFileDescriptor.fileSize AvailableFileDescriptor.fileReadyTime AvailableFileDescriptor.fileExpirationTime AvailableFileDescriptor,fileCompression, AvailableFileDescriptor.fileFormat, >	The output parameter specifies the required file information.
status	M	ENUM (Success, Failure)	

#### 6.3.1.4 Pre-condition

validTimes

Assertion Name	Definition
validTimes	The beginTime is before the invocation time of the operation and the endTime is after beginTime.

#### 6.3.1.5 Post-condition

requiredFileInfoIsReturned

Assertion Name	Definition
requiredFileInfoIsReturned	The required file information is returned.



### 6.3.1.6 Exceptions

Exception Name	Definition
invalidTimes	<b>Condition:</b> (validTimes) not verified. <b>Returned information:</b> output parameter status is set to Failure. <b>Exit state:</b> Entry State.

## 6.4 FileTransferIRPOperations\_2 Interface

### 6.4.1 Operation fileDownloadIndication (O)

#### 6.4.1.1 Definition

This operation allows IRPManager to indicate IRPAgent about completion of the file exchange procedure and related file descriptive information when IRPManager finish downloading one or more files to IRPAgent.

#### 6.4.1.2 Input parameters

Parameter Name	Qualifier	Information type	Comment
fileInfoList	M	LIST of STRUCT < AvailableFileDescriptor.fileLocation, AvailableFileDescriptor.fileSize AvailableFileDescriptor.fileReadyTime AvailableFileDescriptor.fileExpirationTime AvailableFileDescriptor.fileCompression, AvailableFileDescriptor.fileFormat, >	It carries the information of the files downloaded to the IRPAgent.

#### 6.4.1.3 Output parameters

Parameter Name	Qualifier	Matching Information	Comment
status	M	ENUM (Success, Failure)	

#### 6.4.1.4 Pre-condition

validFileInfoList

Assertion Name	Definition
validFileInfoList	The fileInfoList is valid.

#### 6.4.1.5 Post-condition

validFileSize

Assertion Name	Definition
validFileSize	The downloaded file exist and the size of it is greater than zero.

### 6.4.1.6 Exceptions

Exception Name	Definition
InvalidFileInfoList	<b>Condition:</b> (validfileInfoList) not verified. <b>Returned information:</b> output parameter status is set to Failure. <b>Exit state:</b> Entry State.

## 6.5 FileTransferIRPNotifications\_1 Interface

### 6.5.1 Notification notifyFileReady (M)

#### 6.5.1.1 Definition

After the management data files have been prepared ready in the IRPAgent, IRPAgent will emit notification to subscribed IRPManager(s) to notify the availability of the file(s).

#### 6.5.1.2 Input Parameters

Parameter Name	Qualifier	Matching Information	Comment
objectClass	M, Y	FTIRP.objectClass	Notification header - see [4]. It shall carry the FTIRP class name.
objectInstance	M, Y	FTIRP.objectInstance	Notification header - see [4]. It shall carry the DN of the FTIRP.
notificationId	M, N	--	Notification header - see [4].
eventTime	M, Y	--	Notification header - see [4].
systemDN	C, Y	--	Notification header - see [4].
notificationType	M, Y	"notifyFileReady "	Notification header - see [4].
fileInfoList	M, N	See clause 6.3.1.3 (output parameters of listAvailableFiles operation).	It specifies the information of the available file.
additionalText	O, N	String	It carries vendor-specific semantics not defined in the present document.

#### 6.5.1.3 Triggering Event

##### 6.5.1.3.1 From-state

*filesAreReadyAndClosed*

Assertion Name	Definition
filesAreReadyAndClosed	IRPAgent has stored the result data into one or more files which corresponds to management operations.

##### 6.5.1.3.2 To-state

*newNotificationReported*

Assertion Name	Definition
newNotificationReported	The 'notifyFileReady ' notification is emitted to the subscribed IRPManager(s). Based on the information contained in the notification, the IRPManager can get the file(s) through file transfer mechanism.

## 6.5.2 Notification notifyFilePreparationError (M)

### 6.5.2.1 Definition

The subscribed IRPManagers are notified regarding the occurrence of an error during the preparation of the file. This notification is an event and will not be treated as alarms defined in Alarm IRP IS (3GPP TS 32.111-2 [3]).

### 6.5.2.2 Input Parameters

Parameter Name	Qualifier	Matching Information	Comment
objectClass	M, Y	FTIRP.objectClass	See Table 6.5.1.2.
objectInstance	M, Y	FTIRP.objectInstance	See Table 6.5.1.2.
notificationId	M, N	--	See Table 6.5.1.2.
eventTime	M, Y	--	See Table 6.5.1.2.
systemDN	C, Y	--	See Table 6.5.1.2.
notificationType	M, Y	"notifyFilePreparationError"	See Table 6.5.1.2.
fileInfoList	M, N	See clause 6.3.1.3 (output parameters of listAvailableFiles operation).	If file is kept, this parameter identifies the file whose preparation provoked an error. If file is not generated, this parameter is empty.
reason	M, N	--	The detailed reason is given, including <ul style="list-style-type: none"> <li>- errorInPreparation</li> <li>- hardDiskFull</li> <li>- hardDiskFailure</li> <li>- tooManyFiles</li> <li>- collectionTimeOut</li> <li>- incompleteTruncatedFile</li> <li>- corruptedFile</li> <li>- lowMemory</li> <li>- dataNotAvailable</li> </ul>
additionalText	O, N	--	See Table 6.5.1.2.

### 6.5.2.3 Triggering Event

#### 6.5.2.3.1 From-state

*errorInPreparation OR hardDiskFull OR hardDiskFailure OR tooManyFiles OR collectionTimeOut OR incompleteTruncatedFile OR corruptedFile OR lowMemory OR dataNotAvailable*

Assertion Name	Definition
errorInPreparation	There is unspecified error when IRPAgent prepares the files.
hardDiskFull	The file system is full and no more files can be opened.
hardDiskFailure	The hard disk has failed and normal input/output cannot be performed.
tooManyFiles	The file system lacks resource to open a new file to capture management data.
collectionTimeOut	The collection time of management data into files takes too long.
incompleteTruncatedFile	The file is truncated for unspecified reason. The suspect flag should be set in the files.
corruptedFile	The file is corrupted for unspecified reason. The suspect flag should be set in the files.
lowMemory	The system lacks sufficient memory to open a new file to capture management data.
dataNotAvailable	Management data is not available when the collected management object(s) is being read.

#### 6.5.2.3.2 To-state

*fileIsKept OR fileNotGenerated*

Assertion Name	Definition
fileIsKept	The file, whose preparation provokes an error, is kept. And the file naming convention, expiration date, available to be listed, etc. should be treated the same as and be consistent with case when file is prepared successful.
fileNotGenerated	No file was generated and fileInfoList indicates "no file".

---

## Annex A (normative): File Naming Convention

The following convention shall be applied for file naming:

<managementData\_type><file\_ready\_date><file\_ready\_time><file\_expiration\_delta\_time>  
[<specificIRP\_extension>][<separator><RC>]

- 1) The managementData\_type field is the type of the management data contained in the file, the value of managementData\_type field including

"PM" for performance data files,

"CM" for configuration files (except inventory),

"IM" for inventory files,

"TE" for test files,

"CT" for call trace files,

"NL" for notification log files,

"CG" for charging files,

"OT" for other files.

- 2) The file\_ready\_date field is of the form YYYYMMDD, where:

- YYYY is the year in four-digit notation;
- MM is the month in two digit notation (01 - 12);
- DD is the day in two digit notation (01 - 31).

The file\_ready\_date is the date when the file was last closed and made available for upload and the file content will not be changed.

- 3) The file\_ready\_time field is of the form HHMMshhmm, where:

- HH is the two digit hour of the day (local time), based on 24 hour clock (00 - 23);
- MM is the two digit minute of the hour (local time, 00 - 59);
- s is the sign of the local time differential from UTC (+ or -), in case the time differential to UTC is 0 then the sign may be arbitrarily set to "+" or "-";
- hh is the two digit number of hours of the local time differential from UTC (00 - 23);
- mm is the two digit number of minutes of the local time differential from UTC (00 - 59).

The file\_ready\_time is the time when the file was last closed and made available for upload and the file content will not be changed.

- 4) To reduce length of the file name, the file\_expiration\_delta\_time field could be a delta time interval from file ready time. The unit is hour.
- 5) The specificIRP\_extension field is used for other IRPs to extend the extra file naming convention which is not covered by the basic file naming convention defined in FileTransferIRP.
- 6) The RC parameter is a running count, starting with the value of "1", and shall be appended only if the filename is not unique, i.e. more than one file is generated and all other parameters of the file name are identical.
- 7) The separator field is "\_-", which is an underscore character (\_), followed by a minus character (-), followed by an underscore character (\_).

## Annex B (informative): Change history

Change history								
Date	TSG #	TSG Doc.	CR	Rev	Subject/Comment	Cat	Old	New
Dec 2003	SA_22	SP-030637	--	--	Submitted to TSG SA#22 for Information	--	1.0.0	
Jun 2004	SA_24	SP-040244	--	--	Submitted to TSG SA#24 for Approval	--	2.0.0	6.0.0
Jun 2005	SA_28	SP-050292	--	--	Apply Generic System Context	--	6.0.0	6.1.0
Mar 2006	SA_31	SP-060089	0002	--	Correct ambiguity of object class and object instance usage in notification	F	6.1.0	6.2.0
Jun 2007	SA_36	--	--	--	Automatic upgrade to Rel-7 (no CR) at freeze of Rel-7. Deleted reference to CMIP SS, discontinued from R7 onwards.	--	6.2.0	7.0.0
Mar 2009	SA_43	SP-090207	0003	--	Include reference to SOAP Solution Set specification	D	7.0.0	8.0.0
Dec 2009	-	-	-	-	Update to Rel-9 version (MCC)	-	8.0.0	9.0.0
Mar 2011	-	-	-	-	Update to Rel-10 version (MCC)	-	9.0.0	10.0.0
2012-09	-	-	-	-	Update to Rel-11 version (MCC)		10.0.0	<b>11.0.0</b>
2014-10	-	-	-	-	Update to Rel-12 version (MCC)		11.0.0	<b>12.0.0</b>
2016-01	-	-	-	-	Update to Rel-13 version (MCC)		12.0.0	<b>13.0.0</b>
2017-03	SA#75	-	-	-	Promotion to Release 14 without technical change		13.0.0	<b>14.0.0</b>

---

# History

<b>Document history</b>		
V14.0.0	April 2017	Publication