

ETSI TS 132 396 V15.0.0 (2018-07)



**Digital cellular telecommunications system (Phase 2+) (GSM);
Universal Mobile Telecommunications System (UMTS);
LTE;
Telecommunication management;
Delta synchronization Integration Reference Point (IRP);
Solution Set (SS) definitions
(3GPP TS 32.396 version 15.0.0 Release 15)**



Reference

RTS/TSGS-0532396vf00

Keywords

GSM,LTE,UMTS

ETSI

650 Route des Lucioles
F-06921 Sophia Antipolis Cedex - FRANCE

Tel.: +33 4 92 94 42 00 Fax: +33 4 93 65 47 16

Siret N° 348 623 562 00017 - NAF 742 C
Association à but non lucratif enregistrée à la
Sous-Préfecture de Grasse (06) N° 7803/88

Important notice

The present document can be downloaded from:

<http://www.etsi.org/standards-search>

The present document may be made available in electronic versions and/or in print. The content of any electronic and/or print versions of the present document shall not be modified without the prior written authorization of ETSI. In case of any existing or perceived difference in contents between such versions and/or in print, the only prevailing document is the print of the Portable Document Format (PDF) version kept on a specific network drive within ETSI Secretariat.

Users of the present document should be aware that the document may be subject to revision or change of status.

Information on the current status of this and other ETSI documents is available at

<https://portal.etsi.org/TB/ETSIDeliverableStatus.aspx>

If you find errors in the present document, please send your comment to one of the following services:

<https://portal.etsi.org/People/CommiteeSupportStaff.aspx>

Copyright Notification

No part may be reproduced or utilized in any form or by any means, electronic or mechanical, including photocopying and microfilm except as authorized by written permission of ETSI.

The content of the PDF version shall not be modified without the written authorization of ETSI.

The copyright and the foregoing restriction extend to reproduction in all media.

© ETSI 2018.

All rights reserved.

DECT™, **PLUGTESTS™**, **UMTS™** and the ETSI logo are trademarks of ETSI registered for the benefit of its Members.

3GPP™ and **LTE™** are trademarks of ETSI registered for the benefit of its Members and of the 3GPP Organizational Partners.

oneM2M logo is protected for the benefit of its Members.

GSM® and the GSM logo are trademarks registered and owned by the GSM Association.

Intellectual Property Rights

Essential patents

IPRs essential or potentially essential to normative deliverables may have been declared to ETSI. The information pertaining to these essential IPRs, if any, is publicly available for **ETSI members and non-members**, and can be found in ETSI SR 000 314: *"Intellectual Property Rights (IPRs); Essential, or potentially Essential, IPRs notified to ETSI in respect of ETSI standards"*, which is available from the ETSI Secretariat. Latest updates are available on the ETSI Web server (<https://ipr.etsi.org/>).

Pursuant to the ETSI IPR Policy, no investigation, including IPR searches, has been carried out by ETSI. No guarantee can be given as to the existence of other IPRs not referenced in ETSI SR 000 314 (or the updates on the ETSI Web server) which are, or may be, or may become, essential to the present document.

Trademarks

The present document may include trademarks and/or tradenames which are asserted and/or registered by their owners. ETSI claims no ownership of these except for any which are indicated as being the property of ETSI, and conveys no right to use or reproduce any trademark and/or tradename. Mention of those trademarks in the present document does not constitute an endorsement by ETSI of products, services or organizations associated with those trademarks.

Foreword

This Technical Specification (TS) has been produced by ETSI 3rd Generation Partnership Project (3GPP).

The present document may refer to technical specifications or reports using their 3GPP identities, UMTS identities or GSM identities. These should be interpreted as being references to the corresponding ETSI deliverables.

The cross reference between GSM, UMTS, 3GPP and ETSI identities can be found under <http://webapp.etsi.org/key/queryform.asp>.

Modal verbs terminology

In the present document "**shall**", "**shall not**", "**should**", "**should not**", "**may**", "**need not**", "**will**", "**will not**", "**can**" and "**cannot**" are to be interpreted as described in clause 3.2 of the [ETSI Drafting Rules](#) (Verbal forms for the expression of provisions).

"**must**" and "**must not**" are **NOT** allowed in ETSI deliverables except when used in direct citation.

Contents

Intellectual Property Rights	2
Foreword.....	2
Modal verbs terminology.....	2
Foreword.....	5
Introduction	5
1 Scope	6
2 References	6
3 Definitions and abbreviations.....	7
3.1 Definitions	7
3.2 Abbreviations	8
4 Solution Set definitions	8
Annex A (normative): CORBA Solution Set	9
A.1 Architectural features	9
A.1.1 Syntax for Distinguished Names	9
A.1.2 Notification Services	9
A.1.3 Push and Pull Style.....	9
A.1.4 Support multiple notifications in one push operation.....	9
A.1.5 Delta Synchronization Notification Interface.....	9
A.1.5.1 Method push (M).....	9
A.2 Mapping	10
A.2.1 General mapping	10
A.2.2 Operation and notification mapping	10
A.2.3 Operation parameter mapping	10
A.2.4 Notification parameter mapping	13
A.3 Solution Set definitions	18
A.3.1 IDL definition structure.....	18
A.3.2 IDL specification (file name "DeltaSynchronizationConstDefs.idl").....	19
A.3.3 IDL specification (file name "DeltaSynchronizationSystem.idl").....	24
A.3.4 IDL specification (file name "DeltaSynchronizationNotifications.idl").....	27
Annex B (normative): XML definitions	29
B.1 Architectural Features	29
B.1.1 Syntax for Distinguished Names	29
B.1.2 Notification Services	29
B.1.3 IOC definitions	29
B.2 Mapping	29
B.3 Solution Set definitions	29
B.3.1 XML definition structure.....	29
B.3.1.1 Global structure	30
B.3.1.2 XML elements fileHeader and fileFooter	30
B.3.1.2.1 XML elements fileHeaderForDeltaSynchForCM/AlarmData	30
B.3.1.2.2 XML element fileFooter	31
B.3.1.3 Delta synchronisation IRP specific XML elements	32
B.3.1.4 Delta synchronisation IRP XML File Name Conventions	32
B.3.2 Graphical Representation	33
B.3.3 XML Schema	36
B.3.3.1 XML Schema "deltaSynchGeneric.xsd"	36
B.3.3.2 XML Schema "deltaSynchForCMDData.xsd"	37
B.3.3.3 XML Schema "deltaSynchForAlarms.xsd"	38

Annex C (normative): SOAP Solution Set	39
C.1 Architectural features	39
C.1.1 Syntax for Distinguished Names	39
C.1.2 Notification Services	39
C.1.3 Supported W3C specifications	39
C.1.4 Prefixes and namespaces	39
C.2 Mapping	40
C.2.1 Operation and notification mapping	40
C.2.2 Operation parameter mapping	40
C.2.3 Notification parameter mapping.....	41
C.3 Solution Set definitions	41
C.3.1 WSDL definition structure	41
C.3.2 Graphical Representation	41
C.3.3 WSDL specification “DeltaSynchIRPSYSTEM.wsdl”	42
Annex D (informative): Change history	49
History	50

Foreword

This Technical Specification has been produced by the 3rd Generation Partnership Project (3GPP).

The contents of the present document are subject to continuing work within the TSG and may change following formal TSG approval. Should the TSG modify the contents of the present document, it will be re-released by the TSG with an identifying change of release date and an increase in version number as follows:

Version x.y.z

where:

- x the first digit:
 - 1 presented to TSG for information;
 - 2 presented to TSG for approval;
 - 3 or greater indicates TSG approved document under change control.
- y the second digit is incremented for all changes of substance, i.e. technical enhancements, corrections, updates, etc.
- z the third digit is incremented when editorial only changes have been incorporated in the document.

Introduction

The present document is part of a TS-family covering the 3rd Generation Partnership Project; Technical Specification Group Services and System Aspects; Telecommunication management; Communication Surveillance management Integration Reference Point (IRP), as identified below:

32.391: "Delta Synchronization Integration Reference Point (IRP); Requirements"

32.392: "Delta Synchronization Integration Reference Point (IRP): Information Service (IS)"

32.396: "Delta Synchronization Integration Reference Point (IRP): Solution Set definitions"

The Itf-N interface is built up by a number of IRPs and a related Name Convention, which realise the functional capabilities over this interface. The basic structure of the IRPs is defined in 3GPP TS 32.101 [2] and 3GPP TS 32.102 [3].

IRPManagers (typically Network Management Systems) and IRPAgents (typically EMs or NEs) synchronize their data concerning alarms or configuration data. In certain scenarios this synchronization is lost or not done. This IRP provides functionality to significantly reduces the amount of data which needs to be transferred in order to re-establish synchronization.

1 Scope

The present document specifies the Solution Set definitions for the IRP whose semantics is specified in Delta Synchronization IRP IS (3GPP TS 32.392 [5]).

This Solution Set specification is related to 3GPP TS 32.392 V14.0.X [5].

2 References

The following documents contain provisions which, through reference in this text, constitute provisions of the present document.

- References are either specific (identified by date of publication, edition number, version number, etc.) or non-specific.
- For a specific reference, subsequent revisions do not apply.
- For a non-specific reference, the latest version applies. In the case of a reference to a 3GPP document (including a GSM document), a non-specific reference implicitly refers to the latest version of that document *in the same Release as the present document*.

- [1] 3GPP TR 21.905: "Vocabulary for 3GPP Specifications".
- [2] 3GPP TS 32.101: "Telecommunication management; Principles and high level requirements".
- [3] 3GPP TS 32.102: "Telecommunication management; Architecture".
- [4] 3GPP TS 32.150: "Telecommunication management; Integration Reference Point (IRP) Concept and definitions".
- [5] 3GPP TS 32.392: "Telecommunication management; Delta Synchronization Integration Reference Point (IRP): Information Service (IS)".
- [6] 3GPP TS 32.391: "Configuration Management (CM); Delta Synchronization Integration Reference Point (IRP): Requirements".
- [7] 3GPP TS 32.302: "Telecommunication management; Configuration Management (CM); Notification Integration Reference Point (IRP): Information Service (IS)".
- [8] 3GPP TS 32.622: "Telecommunication management; Configuration Management (CM); Generic network resources Integration Reference Point (IRP): Network Resource Model (NRM)".
- [9] 3GPP TS 32.312: "Telecommunication management; Generic Integration Reference Point (IRP) management; Information Service (IS)".
- [10] 3GPP TS 32.602: "Telecommunication management; Configuration Management (CM); Basic CM Integration Reference Point (IRP) management; Information Service (IS)".
- [11] 3GPP TS 32.306: "Telecommunication management; Configuration Management (CM); Notification Integration Reference Point (IRP): Solution Set definitions".
- [12] OMG TC Document telecom/98-11-01: "OMG Notification Service".
<http://www.omg.org/technology/documents/>
- [13] 3GPP TS 32.342: "Telecommunication management; File Transfer (FT) Integration Reference Point (IRP): Information Service (IS)".
- [14] W3C REC-xml-20001006: "Extensible Markup Language (XML) 1.0 (Second Edition)".
- [15] W3C REC-xmlschema-0-20010502: "XML Schema Part 0: Primer".
- [16] W3C REC-xmlschema-1-20010502: "XML Schema Part 1: Structures".
- [17] W3C REC-xmlschema-2-20010502: "XML Schema Part 2: Datatypes".

- [18] W3C REC-xml-names-19990114: "Namespaces in XML"
- [19] 3GPP TS 32.111-6: "Telecommunication management; Fault Management; Part 5: Alarm Integration Reference Point (IRP): Solution Set definitions".
- [20] 3GPP TS 32.616: "Telecommunication management; Configuration Management (CM); Bulk CM Integration Reference Point (IRP): Solution Set definitions".
- [21] 3GPP TS 32.300: "Telecommunication management; Configuration Management (CM); Name convention for Managed Objects".
- [22] W3C SOAP 1.1 specification (<http://www.w3.org/TR/2000/NOTE-SOAP-20000508/>)
- [23] W3C XPath 1.0 specification (<http://www.w3.org/TR/1999/REC-xpath-19991116>)
- [24] W3C WSDL 1.1 specification (<http://www.w3.org/TR/2001/NOTE-wsdl-20010315>)
- [25] W3C SOAP 1.2 specification (<http://www.w3.org/TR/soap12-part1/>)
- [26] 3GPP TS 32.311: "Telecommunication management; Generic Integration Reference Point (IRP): Requirements".

3 Definitions and abbreviations

3.1 Definitions

For the purposes of the present document, the terms and definitions given in TR 21.905 [1], 3GPP TS 32.101 [2], 3GPP TS 32.102 [3], 3GPP TS 32.150 [4] apply. A term defined in the present document takes precedence over the definition of the same term, if any, in TR 21.905 [1].

IRP document version number string (or "IRPVersion"): see 3GPP TS 32.311 [26].

IRP: See 3GPP TS 32.101 [2].

IRPAgent: See 3GPP TS 32.102 [3].

IRPManager: See 3GPP TS 32.102 [3].

Changed alarm: See 3GPP TS 32.391 [6].

Changed instance: See 3GPP TS 32.391 [6].

Delta Synchronisation: See 3GPP TS 32.391 [6].

Delta Synchronisation Point: See 3GPP TS 32.391 [6].

Full Synchronisation: See 3GPP TS 32.391 [6].

XML file: file containing an XML document

XML document: composed of the succession of an optional XML declaration followed by a root XML element [14].

XML declaration: it specifies the version of XML being used, see [14].

XML element: has a type, is identified by a name, may have a set of XML attribute specifications and is either composed of the succession of an XML start-tag followed by the XML content of the XML element followed by an XML end-tag, or composed simply of an XML empty-element tag; each XML element may contain other XML elements, see [14].

empty XML element: having an empty XML content; an empty XML element still possibly has a set of XML attribute specifications; an empty XML element is either composed of the succession of an XML start-tag directly followed by an XML end-tag, or composed simply of an XML empty-element tag, see [14].

XML content (of an XML element): empty if the XML element is simply composed of an XML empty-element tag; otherwise the part, possibly empty, of the XML element between its XML start-tag and its XML end-tag, see [14].

XML start-tag: the beginning of a non-empty XML element is marked by an XML start-tag containing the name and the set of XML attribute specifications of the XML element, see [14].

XML end-tag: the end of a non-empty XML element is marked by an XML end-tag containing the name of the XML element, see [14].

XML empty-element tag: composed simply of an empty-element tag containing the name and the set of XML attribute specifications of the XML element, see [14].

XML attribute specification: has a name and a value, see [14].

DTD: defines structure and content constraints to be respected by an XML document to be valid with regard to this DTD, see [14].

XML schema: more powerful than a DTD, an XML schema defines structure and content constraints to be respected by an XML document to conform with this XML schema; through the use of XML namespaces several XML schemas can be used together by a single XML document; an XML schema is itself also an XML document that shall conform with the XML schema for XML schemas, see [15], [16] and [17].

XML namespace: enables qualifying element and attribute names used in XML documents by associating them with namespaces identified by different XML schemas, see [15], [16] and [17].

XML complex type: defined in an XML schema; cannot be directly used in an XML document; can be the concrete type or the derivation base type for an XML element type or for another XML complex type; ultimately defines constraints for an XML element on its XML attribute specifications and/or its XML content, see [15], [16] and [17].

XML element type: declared by an XML schema; can be directly used in an XML document; as the concrete type of an XML element, directly or indirectly defines constraints on its XML attribute specifications and/or its XML content; can also be the concrete type or the derivation base type for another XML element type, see [15], [16] and [17].

3.2 Abbreviations

For the purposes of the present document, the abbreviations given in TR 21.905 [1], in 3GPP TS 32.101 [2], 3GPP TS 32.102 [3], 3GPP TS 32.150 [4], and the following apply. An abbreviation defined in the present document takes precedence over the definition of the same abbreviation, if any, in TR 21.905 [1].

EM	Element Manager
NM	Network Management
IRP	Integration Reference Point
Itf-N	Interface N
NE	Network Element
SS	Solution Set
IS	Information Service
XML	eXtensible Mark-up Language

4 Solution Set definitions

This specification defines the following 3GPP Delta Synchronization IRP Solution Set definitions:

Annex A provides the CORBA Solution Set.

Annex B provides the XML Definitions.

Annex C provides the SOAP Solution Set.

Annex A (normative): CORBA Solution Set

This annex contains the CORBA Solution Set for the IRP whose semantics is specified in Delta Synchronization IRP: Information Service (3GPP TS 32.392 [5]).

A.1 Architectural features

The overall architectural feature of Delta Synchronization IRP is specified in 3GPP TS 32.392 [5].

A.1.1 Syntax for Distinguished Names

The syntax of a Distinguished Name is defined in 3GPP TS 32.300 [21].

A.1.2 Notification Services

In implementations of CORBA SS, IRPAgent conveys FT Information to IRPManager via OMG Notification Service (OMG Notification Service [12]).

A necessary and sufficient sub set of OMG Notification Services shall be used to support DeltaSynchronizationNotifications notifications as specified in 3GPP TS 32.392 [5].

A.1.3 Push and Pull Style

OMG Notification Service defines two styles of interaction. One is called push style. In this style, IRPAgent pushes notifications to IRPManager as soon as they are available. The other is called pull style. In this style, IRPAgent keeps the notifications till IRPManager requests for them.

This CORBA SS specifies that support of Push style is Mandatory (M) and that support of Pull style is Optional (O).

A.1.4 Support multiple notifications in one push operation

For efficiency reasons, IRPAgent may send multiple notifications using one single push operation. To pack multiple notifications into one push operation, IRPAgent may wait and not invoke the push operation as soon as notifications are available. To avoid IRPAgent to wait for an extended period of time that is objectionable to IRPManager, IRPAgent shall implement an IRPAgent wide timer configurable by administrator. On expiration of this timer, IRPAgent shall invoke push if there is at least one notification to be conveyed to IRPManager. This timer is re-started after each push invocation.

A.1.5 Delta Synchronization Notification Interface

OMG CORBA Notification push operation is used to realise the notification of Delta Synchronization IRP Notifications. All the notifications in this interface are implemented using this push_structured_event method.

A.1.5.1 Method `push` (M)

```
module CosNotifyComm {
...
  Interface SequencePushConsumer : NotifyPublish {
    void push_structured_events(
      in CosNotification::EventBatch notifications)
      raises( CosEventComm::Disconnected);
...
  }; // SequencePushConsumer
...
}; // CosNotifyComm
```

NOTE 1: The `push_structured_events` method takes an input parameter of type `EventBatch` as defined in the `OMG CosNotification` module (OMG Notification Service [10]). This data type is the same as a sequence of Structured Events. Upon invocation, this parameter will contain a sequence of Structured Events being delivered to `IRPManager` by `IRPAgent` to which it is connected.

NOTE 2: The maximum number of events that will be transmitted within a single invocation of this operation is controlled by `IRPAgent` wide configuration parameter.

NOTE 3: The amount of time the supplier (`IRPAgent`) of a sequence of Structured Events will accumulate individual events into the sequence before invoking this operation is controlled by `IRPAgent` wide configuration parameter as well.

NOTE 4: `IRPAgent` may push `EventBatch` with only one Structured Event.

A.2 Mapping

A.2.1 General mapping

Not applicable.

A.2.2 Operation and notification mapping

The Delta Synchronization IS defines semantics of operations visible across the Itf-N. Table A.2.2-1 indicates mapping of these operations and notifications to their equivalents defined in this SS.

Table A.2.2-1: Mapping from IS Operation to SS equivalents

IS Operation / Notification (3GPP TS 32.392)	SS Method	Qualifier
<code>manageDeltaSynchronization</code>	<code>manageDeltaSynchronization</code>	M
<code>getAvailableDeltaSynchPoints</code>	<code>getAvailableDeltaSynchPoints</code>	O
<code>triggerDeltaSynchOfCMDData</code>	<code>triggerDeltaSynchOfCMDData</code>	O
<code>triggerDeltaSynchOfAlarms</code>	<code>triggerDeltaSynchOfAlarms</code>	O
<code>notifyStatusOfDeltaSynchronization</code>	<code>notifyStatusOfDeltaSynchronization</code>	M
<code>notifyNewDeltaSynchPoint</code>	<code>notifyNewDeltaSynchPoint</code>	O

A.2.3 Operation parameter mapping

The Delta Synchronization IS defines semantics of parameters carried in operations across the Itf-N. The following tables indicate the mapping of these parameters, as per operation, to their equivalents defined in this SS.

Table A.2.3-1: Mapping from IS `manageDeltaSynchronization` parameters to SS equivalents

IS Operation parameter	SS Method parameter	Qualifier
<code>managerReference</code>	<code>DeltaSynchronizationConstDefs::ManagerReference</code>	M
<code>manageDeltaSynchForAlarmData</code>	<code>DeltaSynchronizationConstDefs::ManageDeltaSynchForXDataConditional</code>	CM
<code>manageDeltaSynchForCMDData</code>	<code>DeltaSynchronizationConstDefs::ManageDeltaSynchForXDataConditional</code>	CM
<code>status</code>	Exceptions: <code>DeltaSynchronizationConstDefs::ManageDeltaSynchronization</code> , <code>GenericIRPManagementSystem::ParameterNotSupported</code> , <code>GenericIRPManagementSystem::InvalidParameter</code> , <code>GenericIRPManagementSystem::ValueNotSupported</code> , <code>GenericIRPManagementSystem::OperationNotSupported</code>	M

Table A.2.3-2: Mapping from IS `getAvailableDeltaSynchPoints` parameters to SS equivalents

IS Operation parameter	SS Method parameter	Qualifier
managerReference	DeltaSynchronizationConstDefs::ManagerReferenceOpt	O
synchPointsForCMDDataRequested	DeltaSynchronizationConstDefs::SynchPointsRequestedConditional	CM
synchPointsForAlarmDataRequested	DeltaSynchronizationConstDefs::SynchPointsRequestedConditional	CM
synchPointListForAlarms	DeltaSynchronizationConstDefs::SynchPointListConditional	CM
synchPointListForCMDData	DeltaSynchronizationConstDefs::SynchPointListConditional	CM
status	Exceptions: DeltaSynchronizationConstDefs::DeltaSynchNotSupportedForCMDData, DeltaSynchronizationConstDefs::DeltaSynchNotSupportedForAlarmData, DeltaSynchronizationConstDefs::DeltaSynchNotActive, DeltaSynchronizationConstDefs::DeltaSynchForCMDDataDeactivated, DeltaSynchronizationConstDefs::DeltaSynchForAlarmDataDeactivated, GenericIRPManagementSystem::ParameterNotSupported, GenericIRPManagementSystem::InvalidParameter, GenericIRPManagementSystem::ValueNotSupported, GenericIRPManagementSystem::OperationNotSupported	M

Table A.2.3-3: Mapping from IS `triggerDeltaSynchOfCMDData` parameters to SS equivalents

IS Operation parameter	SS Method parameter	Qualifier
managerReference	DeltaSynchronizationConstDefs::ManagerReferenceOpt	O
dataRequested	DeltaSynchronizationConstDefs::CMDDataRequestedOpt	O
baseMOInstance	KernelCmConstDefs::DNOpt	O
scope	KernelCmConstDefs::ScopeTypeOpt	O
synchPoint	DeltaSynchronizationConstDefs::SynchPoint	M
deltaLists	DeltaSynchronizationConstDefs::DeltaListsConditional	CM
newSynchPoint	DeltaSynchronizationConstDefs::SynchPointConditional	CM
status	Exceptions: DeltaSynchronizationConstDefs::TriggerDeltaSynchOfCMDData, DeltaSynchronizationConstDefs::SynchronizationPointTooLongAgo, DeltaSynchronizationConstDefs::TooManyChangesFullSynchronizationRecommended, DeltaSynchronizationConstDefs::SynchPointUnknown, DeltaSynchronizationConstDefs::DeltaSynchNotSupportedForCMDData, DeltaSynchronizationConstDefs::DeltaSynchForCMDDataDeactivated, DeltaSynchronizationConstDefs::DeltaSynchNotActive, GenericIRPManagementSystem::ParameterNotSupported, GenericIRPManagementSystem::InvalidParameter, GenericIRPManagementSystem::ValueNotSupported, GenericIRPManagementSystem::OperationNotSupported	M

Table A.2.3-4: Mapping from IS triggerDeltaSynchOfAlarms parameters to SS equivalents

IS Operation parameter	SS Method parameter	Qualifier
managerReference	DeltaSynchronizationConstDefs::ManagerReference	M
dataRequested	DeltaSynchronizationConstDefs::AlarmDataRequested	M
baseMOInstance	KernelCmConstDefs::DN	O
scope	KernelCmConstDefs::ScopeTypeOpt	O
synchPoint	DeltaSynchronizationConstDefs::SynchPoint	M
deltaLists	DeltaSynchronizationConstDefs::DeltaListsConditional	CM
newSynchPoint	DeltaSynchronizationConstDefs::SynchPointConditional	CM
status	Exceptions: DeltaSynchronizationConstDefs::TriggerDeltaSynchOfAlarms, DeltaSynchronizationConstDefs::SynchronizationPointTooLongAgo, DeltaSynchronizationConstDefs::TooManyChangesFullSynchronizationRecommended DeltaSynchronizationConstDefs::SynchPointUnknown, DeltaSynchronizationConstDefs::DeltaSynchNotSupportedForAlarms, DeltaSynchronizationConstDefs::DeltaSynchForAlarmsNotActive, DeltaSynchronizationConstDefs::DeltaSynchNotActive, GenericIRPManagementSystem::ParameterNotSupported, GenericIRPManagementSystem::InvalidParameter, GenericIRPManagementSystem::ValueNotSupported, GenericIRPManagementSystem::OperationNotSupported	M

A.2.4 Notification parameter mapping

The delta synchronization Information Service defines semantics of parameters carried in notifications. The following table indicates the mapping of these parameters to their OMG CORBA Structured Event (defined in OMG Notification Service [12]) equivalents. The composition of OMG Structured Event, as defined in the OMG Notification Service [12], is:

```
Header
  Fixed Header
    domain_name
    type_name
    event_name
  Variable Header
Body
  filterable_body_fields
  remaining_body
```

The following tables list all OMG Structured Event attributes in the second column. The first column identifies the delta synchronization Information Service defined notification parameters.

Table A.2.4-1: Mapping for notifyStatusOfDeltaSynchronization

IS Parameters	OMG CORBA Structured Event attribute	Qualifier	Comment
There is no corresponding IS attribute.	domain_name	M	It carries the IRP document version number string. See clause 3.1. It indicates the syntax and semantics of the Structured Event as defined by the present document.
notificationType	type_name	M	This is the NotifyDeltaSynchOfInstancesDeactivated of module DeltaSynchronizationNotifications.
There is no corresponding IS attribute.	event_name	M	It carries no information.
There is no corresponding IS attribute.	Variable Header		
objectClass, objectInstance	One NV pair of filterable_body_fields	M	NV stands for name-value pair. Order arrangement of NV pairs is not significant. The name of NV-pair is always encoded in string. Name of this NV pair is the MANAGED_OBJECT_INSTANCE of interface AttributeNameValue of module NotificationIRPConstDefs. Value of NV pair is a string. See corresponding table in Notification IRP: CORBA SS (3GPP TS 32.306 [11]).
notificationId	One NV pair of remaining_body	M	Name of NV pair is the NOTIFICATION_ID of interface AttributeNameValue of module NotificationIRPConstDefs. Value of NV pair is a long. See corresponding table in Notification IRP: CORBA SS (3GPP TS 32.306 [11]).
eventTime	One NV pair of filterable_body_fields	M	Name of NV pair is the EVENT_TIME of interface AttributeNameValue of module NotificationIRPConstDefs. Value of NV pair is IRPTime. See corresponding table in Notification IRP: CORBA SS (3GPP TS 32.306 [11]).
systemDN	One NV pair of filterable_body_fields	M	Name of NV pair is the SYSTEM_DN of interface AttributeNameValue of module NotificationIRPConstDefs. Value of NV pair is a string. See corresponding table in Notification IRP: CORBA SS (3GPP TS 32.306 [11]).
managerReference	One NV pair of remaining_body	M	Name of NV pair is the MANAGER_REFERENCE of interface notifyDeltaSynchOfInstancesDeactivated of module DeltaSynchronizationNotifications. Value of NV pair is ManagerReference of module DeltaSynchronizationConstDefs.
deltaSynchStatusForCMDData	One NV pair of remaining_body	M	Name of NV pair is the DELTA_SYNCH_STATUS_FOR_CMDATA of interface notifyDeltaSynchOfInstancesDeactivated of module DeltaSynchronizationNotifications. Value of NV pair is DeltaSynchStatus of module DeltaSynchronizationConstDefs.
deltaSynchStatusForAlarmData	One NV pair of remaining_body	M	Name of NV pair is the DELTA_SYNCH_STATUS_FOR_ALARM_DATA of interface notifyDeltaSynchOfInstancesDeactivated of module DeltaSynchronizationNotifications. Value of NV pair is DeltaSynchStatus of module DeltaSynchronizationConstDefs.

Table A.2.4-2: Mapping for `notifyNewDeltaSynchPoint`

IS Parameters	OMG CORBA Structured Event attribute	Qualifier	Comment
There is no corresponding IS attribute.	domain_name	M	It carries the IRP document version number string. See subclause 3.1 It indicates the syntax and semantics of the Structured Event as defined by the present document.
notificationType	type_name	M	This is the NotifyDeltaSynchOfAlarmsDeactivated of module DeltaSynchronizationNotifications.
There is no corresponding IS attribute.	event_name	M	It carries no information.
There is no corresponding IS attribute.	Variable Header		
objectClass, objectInstance	One NV pair of filterable_body_fields	M	NV stands for name-value pair. Order arrangement of NV pairs is not significant. The name of NV-pair is always encoded in string. Name of this NV pair is the MANAGED_OBJECT_INSTANCE of interface AttributeNameValue of module NotificationIRPConstDefs. Value of NV pair is a string. See corresponding table in Notification IRP: CORBA SS (3GPP TS 32.306 [11]).
notificationId	One NV pair of remaining_body	M	Name of NV pair is the NOTIFICATION_ID of interface AttributeNameValue of module NotificationIRPConstDefs. Value of NV pair is a long. See corresponding table in Notification IRP: CORBA SS (3GPP TS 32.306 [11]).
eventTime	One NV pair of filterable_body_fields	M	Name of NV pair is the EVENT_TIME of interface AttributeNameValue of module NotificationIRPConstDefs. Value of NV pair is IRPTime. See corresponding table in Notification IRP: CORBA SS (3GPP TS 32.306 [11]).
systemDN	One NV pair of filterable_body_fields	M	Name of NV pair is the SYSTEM_DN of interface AttributeNameValue of module NotificationIRPConstDefs. Value of NV pair is a string. See corresponding table in Notification IRP: CORBA SS (3GPP TS 32.306 [11]).
newSynchPoint	One NV pair of remaining_body	M	Name of NV pair is the NEW_DELTA_SYNCH_POINT of interface notifyDeltaSynchOfAlarmsDeactivated of module DeltaSynchronizationNotifications. Value of NV pair is SynchPoint of module DeltaSynchronizationConstDefs.
requestedSynchPoint	One NV pair of remaining_body	M	Name of NV pair is the REQUESTED_SYNCH_POINT of interface notifyDeltaSynchOfAlarmsDeactivated of module DeltaSynchronizationNotifications. Value of NV pair is SynchPoint of module DeltaSynchronizationConstDefs.
deltaSynchPointType	One NV pair of remaining_body	M	Name of NV pair is the DELTA_SYNCH_POINT_TYPE of interface notifyDeltaSynchOfAlarmsDeactivated of module DeltaSynchronizationNotifications. Value of NV pair is DeltaSynchPointType of module DeltaSynchronizationConstDefs.
triggeredByAgentOrManager	One NV pair of remaining_body	M	Name of NV pair is the TRIGGERED_BY_AGENT_OR_MANAGER of interface notifyDeltaSynchOfAlarmsDeactivated of module DeltaSynchronizationNotifications. Value of NV pair is TriggeredByAgentOrManager of module DeltaSynchronizationConstDefs.

agentOrManagerReference	One NV pair of remaining_body	M	Name of NV pair is the AGENT_OR_MANAGER_REFERENCE of interface notifyDeltaSynchOfAlarmsDeactivated of module DeltaSynchronizationNotifications. Value of NV pair is AgentOrManagerReference of module DeltaSynchronizationConstDefs.
-------------------------	-------------------------------	---	---

A.3 Solution Set definitions

A.3.1 IDL definition structure

Clause A.3.2 defines the constants and types used by the Delta Synchronization IRP.

Clause A.3.3 defines the operations which are performed by the Delta Synchronization IRP agent.

Clause A.3.4 defines the notifications which are emitted by the Delta Synchronization IRP agent.

A.3.2 IDL specification (file name "DeltaSynchronizationConstDefs.idl")

```
// File: DeltaSynchronizationConstDefs.idl
#ifndef _DELTA_SYNCHRONIZATION_CONST_DEFS_IDL_
#define _DELTA_SYNCHRONIZATION_CONST_DEFS_IDL_

#include <TimeBase.idl>

#include <DeltaSynchronizationConstDefs.idl>
#include <GenericIRPManagementConstDefs.idl>
#include <KernelCmConstDefs.idl>
#include <FileTransferIRPConstDefs.idl>
#include <AlarmIRPConstDefs.idl>

//FileTransferIRPConstDefs::FileLocation value;

// This statement must appear after all include statements
#pragma prefix "3gppsa5.org"

/* ## Module: DeltaSynchronizationConstDefs */

module DeltaSynchronizationConstDefs
{
/*****
/* definition of types used in several operations for Delta Synchronization: */
*****/

/* types used in several operations: */

typedef string ManagerReference;

typedef string AgentOrManagerReference;

/*
ManagerReferenceConditional is a type carrying an optional parameter.
The boolean shall be TRUE, if the condition described in TS 32.392 is fulfilled. In this case the
value is present. Otherwise the value is be absent.
*/
union ManagerReferenceConditional switch (boolean)
{
    case TRUE: ManagerReference value;
};

/*
ManagerReferenceOpt is a type carrying an optional parameter.
The boolean shall be TRUE, if the operation request uses this parameter. In this case the value is
present. Otherwise the value is absent.
*/
union ManagerReferenceOpt switch (boolean)
{
    case TRUE: ManagerReference value;
};

enum ManageDeltaSynchForXData {ACTIVATE, DEACTIVATE};

/*
ManageDeltaSynchForXDataConditional is a type carrying a conditional parameter.
The boolean shall be TRUE, if the condition described in TS 32.392 is fulfilled. In this case the
value is present. Otherwise the value is absent.
*/
union ManageDeltaSynchForXDataConditional switch (boolean)
{
    case TRUE: ManageDeltaSynchForXData value;
};

typedef TimeBase::UtcT SynchPoint;

/*
SynchPointConditional is a type carrying a conditional parameter.

```

The boolean shall be TRUE, if the condition described in TS 32.392 is fulfilled. In this case the value is present. Otherwise the value is absent.

```
*/
union SynchPointConditional switch (boolean)
{
    case TRUE: SynchPoint value;
};
```

/*
SynchPointOpt is a type carrying an optional parameter.
The boolean shall be TRUE, if the operation request uses this parameter. In this case the value is present. Otherwise the value is absent.

```
*/
union SynchPointOpt switch (boolean)
{
    case TRUE: SynchPoint value;
};
```

/*
ScopeTypeOpt is a type carrying an optional parameter.
The boolean shall be TRUE, if the operation request uses this parameter. In this case the value is present. Otherwise the value is absent.

```
*/
union ScopeTypeOpt switch (boolean)
{
    case TRUE: KernelCmConstDefs::ScopePara value;
};
```

/*
BaseMOInstanceOpt is a type carrying an optional parameter.
The boolean shall be TRUE, if the operation request uses this parameter. In this case the value is present. Otherwise the value is absent.

```
*/
union BaseMOInstanceOpt switch (boolean)
{
    case TRUE: GenericIRPManagementConstDefs::DN value;
};
```

```
enum Status {SUCCESS, FAILURE};
```

```
/* types used in operation manageDeltaSynchronization */
```

```
enum ActivatedStatus {ACTIVATED, DEACTIVATED };
typedef ActivatedStatus ManageDeltaSynchMode;
```

```
/* types used in operation getAvailableDeltaSynchPoints */
```

```
typedef boolean SynchPointsRequested;
```

/*
SynchPointsRequestedConditional is a type carrying a conditional parameter.
The boolean shall be TRUE, if the condition described in TS 32.392 is fulfilled. Otherwise the value may be absent.

```
*/
union SynchPointsRequestedConditional switch (boolean)
{
    case TRUE: SynchPointsRequested value;
};
```

```
typedef sequence <SynchPoint> SynchPointList;
```

/*
SynchPointListConditional is a type carrying an optional parameter.
The boolean shall be TRUE, if the condition described in TS 32.392 is fulfilled. In this case the value is present. Otherwise the value is be absent.

```
*/
union SynchPointListConditional switch (boolean)
{
    case TRUE: SynchPointList value;
};
```

```

};

/*****
/* types used in operation triggerDeltaSynchOfCMDData and
/* in operation triggerDeltaSynchOfAlarmData
*****/

/*
AttributeListConditional is a type carrying a conditional parameter.
The boolean shall be TRUE, if the operation's dnsOnly=FALSE. In this case the value is present.
Otherwise the value is absent.
*/
union AttributeListConditional switch (boolean)
{
case TRUE: GenericIRPManagementConstDefs::MOAttributeSet value;
};

struct ListedInstance
{
GenericIRPManagementConstDefs::DN moInstance; /* DN is a string; */
AttributeListConditional attributeList;
};

typedef sequence <ListedInstance> ListOfInstances;

struct DeltaListsWithRealLists
{
TimeBase::UtcT startTime;
TimeBase::UtcT endTime;
ListOfInstances listOfCreatedInstances;
ListOfInstances listOfChangedInstances;
ListOfInstances listOfDeletedInstances;
};

struct AlarmDeltaListsWithRealLists
{
TimeBase::UtcT startTime;
TimeBase::UtcT endTime;
AlarmIRPConstDefs::AlarmInformationSeq listOfNewAlarms;
AlarmIRPConstDefs::AlarmInformationSeq listOfChangedAlarms;
AlarmIRPConstDefs::AlarmInformationIdSeq listOfDeletedAlarms;
};

typedef sequence <FileTransferIRPConstDefs::FileLocation> FileLocationList;

struct DeltaListsWithFileReferences
{
TimeBase::UtcT startTime;
TimeBase::UtcT endTime;
FileLocationList fileList;
/* if several files are used, then they shall be processed by the IRPmanager in sequence, i.e. first
file first, second file as second, ... */
};

enum DeltaListContentChoice {REAL_LISTS, FILE_REFERENCES};

//The CmDeltaList may contain a list of ListOfInstances or a list of filenames
union CmDeltaLists switch (DeltaListContentChoice)
{
case REAL_LISTS: DeltaListsWithRealLists deltaListRealLists;
case FILE_REFERENCES: DeltaListsWithFileReferences deltaListFileReferences;
};

//The AlarmDeltaLists may contain a list of ListOfInstances or a list of filenames
union AlarmDeltaLists switch (DeltaListContentChoice)
{
case REAL_LISTS: AlarmDeltaListsWithRealLists deltaListRealLists;
case FILE_REFERENCES: DeltaListsWithFileReferences deltaListFileReferences;
};

```

```

/*
CmDeltaListsConditional is a type carrying a conditional parameter.
The boolean shall be TRUE, if the condition described in TS 32.392 is fulfilled. In this case
the value is present. Otherwise the value is absent.
*/
union CmDeltaListsConditional switch (boolean)
{
    case TRUE: CmDeltaLists value;
};

/*
AlarmDeltaListsConditional is a type carrying a conditional parameter.
The boolean shall be TRUE, if the condition described in TS 32.392 is fulfilled. In this case
the value is present. Otherwise the value is absent.
*/
union AlarmDeltaListsConditional switch (boolean)
{
    case TRUE: AlarmDeltaLists value;
};

/*****
/* types used in operation triggerDeltaSynchOfAlarmData */
*****/

enum AlarmDataRequested { ALARM_IDS_ONLY, COMPLETE_ALARM_INFORMATION };

/*
AlarmDataRequestedOpt is a type carrying an optional parameter.
The boolean shall be TRUE, if the operation request uses this parameter. In this case the value
is present. Otherwise the value is absent.
*/
union AlarmDataRequestedOpt switch (boolean)
{
    case TRUE: AlarmDataRequested value;
};

/*****
/* types used in operation triggerDeltaSynchOfCMDData */
*****/

enum CMDDataRequested { DNS_ONLY, COMPLETE_DATA_SET };

/*
CMDDataRequestedOpt is a type carrying an optional parameter.
The boolean shall be TRUE, if the operation request uses this parameter. In this case the value
is present. Otherwise the value is absent.
*/
union CMDDataRequestedOpt switch (boolean)
{
    case TRUE: CMDDataRequested value;
};

/*****
/* definition of types in notifications for Delta Synchronization */
*****/

enum DeltaSynchPointType { DELTA_SYNCH_POINT_FOR_ALARM, DELTA_SYNCH_POINT_FOR_CM_DATA };

typedef ActivatedStatus DeltaSynchStatus;

enum TriggeredBy { IRP_AGENT, IRP_MANAGER };

/*****
/* Definition of parameters specified in notifications for Delta Synchronization */
*****/

interface AttributeNameValue
{
    const string MANAGER_REFERENCE = "MANAGER_REFERENCE";
    const string AGENT_OR_MANAGER_REFERENCE = "AGENT_OR_MANAGER_REFERENCE";
    const string DELTA_SYNCH_STATUS_FOR_CMDATA = "DELTA_SYNCH_STATUS_FOR_CMDATA";
    const string DELTA_SYNCH_STATUS_FOR_ALARM_DATA = "DELTA_SYNCH_STATUS_FOR_ALARM_DATA";
    const string NEW_DELTA_SYNCH_POINT = "NEW_DELTA_SYNCH_POINT";
};

```

```
const string DELTA_SYNCH_POINT_TYPE = "DELTA_SYNCH_POINT_TYPE";  
const string REQUESTED_SYNCH_POINT = "REQUESTED_SYNCH_POINT";  
const string TRIGGERED_BY_AGENT_OR_MANAGER = "TRIGGERED_BY_AGENT_OR_MANAGER";  
};
```

```
};
```

```
#endif // _DELTA_SYNCHRONIZATION_CONST_DEFS_IDL_
```

A.3.3 IDL specification (file name "DeltaSynchronizationSystem.idl")

```
//File: DeltaSynchronizationSystem.idl
#ifndef _DELTA_SYNCHRONIZATION_SYSTEM_IDL_
#define _DELTA_SYNCHRONIZATION_SYSTEM_IDL_

#include <KernelCmConstDefs.idl>
#include <DeltaSynchronizationConstDefs.idl>
#include <GenericIRPManagementSystem.idl>
#include <AlarmIRPConstDefs.idl>
#include <AlarmIRPSystem.idl>
#include <NotificationLogIRPSystem.idl>

// This statement must appear after all include statements
#pragma prefix "3gppsa5.org"

/* ## Module: DeltaSynchronizationSystem */

module DeltaSynchronizationSystem
{
    /*
    If the system fails to complete an operation, then it can provide a reason
    to qualify the exception. The semantics carried in this reason are outside
    the scope of the present document.
    */

    exception ManageDeltaSynchronization { string reason; };
    exception GetAvailableDeltaSynchPoints { string reason; };
    exception TriggerDeltaSynchOfCMDData { string reason; };
    exception TriggerDeltaSynchOfAlarms { string reason; };
    exception SynchronizationPointTooLongAgo { string reason; };
    exception TooManyChangesFullSynchronizationRecommended { string reason; };
    exception DeltaSynchNotSupportedForCMDData { string reason; };
    exception DeltaSynchNotSupportedForAlarmData { string reason; };
    exception DeltaSynchNotActive { string reason; };
    exception DeltaSynchForCMDDataDeactivated { string reason; };
    exception DeltaSynchForAlarmDataDeactivated { string reason; };
    exception SynchPointTooLongAgo { string reason; };
    exception SynchPointUnknown { string reason; };
    exception DeltaSynchNotSupportedForAlarms { string reason; };
    exception DeltaSynchForAlarmsNotActive { string reason; };

    interface DeltaSynchGenericParts
    {
        DeltaSynchronizationConstDefs::Status manageDeltaSynchronization
        /* for the purpose of this operation see 3GPP TS 32.392 */
        (
            in DeltaSynchronizationConstDefs::ManagerReference managerReference,
            in DeltaSynchronizationConstDefs::ManageDeltaSynchForXDataConditional
                manageDeltaSynchForAlarmData,
            in DeltaSynchronizationConstDefs::ManageDeltaSynchForXDataConditional
                manageDeltaSynchForCMDData
        )
        raises
        (
            ManageDeltaSynchronization,
            GenericIRPManagementSystem::ParameterNotSupported,
            GenericIRPManagementSystem::InvalidParameter,
            GenericIRPManagementSystem::ValueNotSupported,
            GenericIRPManagementSystem::OperationNotSupported
        );

        DeltaSynchronizationConstDefs::Status getAvailableDeltaSynchPoints
        /* for the purpose of this operation see 3GPP TS 32.392 */
        (
            in DeltaSynchronizationConstDefs::ManagerReferenceOpt managerReference,
            in DeltaSynchronizationConstDefs::SynchPointsRequestedConditional
                synchPointsForCMDDataRequested,
            in DeltaSynchronizationConstDefs::SynchPointsRequestedConditional
                synchPointsForAlarmDataRequested,
            out DeltaSynchronizationConstDefs::SynchPointListConditional synchPointListForAlarms,

```

```

        out DeltaSynchronizationConstDefs::SynchPointListConditional synchPointListForCMDData
    )
    raises
    (
        GetAvailableDeltaSynchPoints,
        DeltaSynchNotSupportedForCMDData,
        DeltaSynchNotSupportedForAlarmData,
        DeltaSynchNotActive,
        DeltaSynchForCMDDataDeactivated,
        DeltaSynchForAlarmDataDeactivated,
        GenericIRPManagementSystem::ParameterNotSupported,
        GenericIRPManagementSystem::InvalidParameter,
        GenericIRPManagementSystem::ValueNotSupported,
        GenericIRPManagementSystem::OperationNotSupported
    );
};

```

```

interface DeltaSynchOfCMDData
{
    DeltaSynchronizationConstDefs::Status triggerDeltaSynchOfCMDData
    /* for the purpose of this operation see 3GPP TS 32.392 */
    (
        in DeltaSynchronizationConstDefs::ManagerReferenceOpt managerReference,
        in DeltaSynchronizationConstDefs::CMDDataRequestedOpt cmDataRequested,
        in DeltaSynchronizationConstDefs::BaseMOInstanceOpt baseMOInstance,
        in DeltaSynchronizationConstDefs::ScopeTypeOpt scope,
        in DeltaSynchronizationConstDefs::SynchPoint synchPoint,
        out DeltaSynchronizationConstDefs::CmDeltaListsConditional deltaLists,
        out DeltaSynchronizationConstDefs::SynchPointConditional newSynchPoint
    )
    raises
    (
        TriggerDeltaSynchOfCMDData,
        SynchronizationPointTooLongAgo,
        TooManyChangesFullSynchronizationRecommended,
        SynchPointUnknown,
        DeltaSynchNotSupportedForCMDData,
        DeltaSynchForCMDDataDeactivated,
        DeltaSynchNotActive,
        GenericIRPManagementSystem::ParameterNotSupported,
        GenericIRPManagementSystem::InvalidParameter,
        GenericIRPManagementSystem::ValueNotSupported,
        GenericIRPManagementSystem::OperationNotSupported
    );
};

```

```

interface DeltaSynchOfAlarmData
{
    DeltaSynchronizationConstDefs::Status triggerDeltaSynchOfAlarms
    /* for the purpose of this operation see 3GPP TS 32.392 */
    (
        in DeltaSynchronizationConstDefs::ManagerReferenceOpt managerReference,
        in DeltaSynchronizationConstDefs::AlarmDataRequestedOpt alarmDataRequested,
        in DeltaSynchronizationConstDefs::BaseMOInstanceOpt baseMOInstance,
        in DeltaSynchronizationConstDefs::ScopeTypeOpt scope,
        in DeltaSynchronizationConstDefs::SynchPoint synchPoint,
        out DeltaSynchronizationConstDefs::AlarmDeltaListsConditional deltaLists,
        out DeltaSynchronizationConstDefs::SynchPointConditional newSynchPoint
    )
    raises
    (
        TriggerDeltaSynchOfAlarms,
        SynchronizationPointTooLongAgo,
        TooManyChangesFullSynchronizationRecommended,
        SynchPointUnknown,
        DeltaSynchNotSupportedForAlarms,
        DeltaSynchForAlarmsNotActive,
        DeltaSynchNotActive,
        GenericIRPManagementSystem::ParameterNotSupported,

```

```
GenericIRPManagementSystem::InvalidParameter,  
GenericIRPManagementSystem::ValueNotSupported,  
GenericIRPManagementSystem::OperationNotSupported  
);  
  
};  
  
interface DeltaSynchIRPSystem : DeltaSynchGenericParts, DeltaSynchOfCMDData,  
    DeltaSynchOfAlarmData, GenericIRPManagementSystem::GenericIRPManagement{};  
  
};  
#endif // _DELTA_SYNCHRONIZATION_SYSTEM_IDL_
```

A.3.4 IDL specification (file name "DeltaSynchronizationNotifications.idl")

```
//File: DeltaSynchronizationNotifications.idl
#ifndef _DELTA_SYNCHRONIZATION_NOTIFICATIONS_IDL_
#define _DELTA_SYNCHRONIZATION_NOTIFICATIONS_IDL_

#include <DeltaSynchronizationConstDefs.idl>
#include <NotificationIRPNotifications.idl>

// This statement must appear after all include statements
#pragma prefix "3gppsa5.org"

/* ## Module: DeltaSynchronizationNotifications
This contains the specification of notifications of Delta Synchronization.
=====
*/
module DeltaSynchronizationNotifications
{

    /* Constant definitions for the NotifyDeltaSynchOfInstancesDeactivated notification */

    interface notifyDeltaSynchOfInstancesDeactivated: NotificationIRPNotifications::Notify
    {
        const string EVENT_TYPE = "notifyStatusOfDeltaSynchronization";

        /**
         * This constant defines the name of the ManagerReference property,
         * which is transported in the filterable_body fields.
         * The data type for the value of this property is
         * DeltaSynchronizationConstDefs::ManagerReferenceConditional.
         */
        const string MANAGER_REFERENCE =
            DeltaSynchronizationConstDefs::AttributeNameValue::MANAGER_REFERENCE;

        /**
         * This constant defines the name of the DeltaSynchStatusForCMDData property,
         * which is transported in the filterable_body fields.
         * The data type for the value of this property is
         * DeltaSynchronizationConstDefs::DeltaSynchStatus.
         */
        const string DELTA_SYNCH_STATUS_FOR_CMDDATA =
            DeltaSynchronizationConstDefs::AttributeNameValue::DELTA_SYNCH_STATUS_FOR_CMDDATA;

        /**
         * This constant defines the name of the DeltaSynchStatusForAlarmData property,
         * which is transported in the filterable_body fields.
         * The data type for the value of this property is
         * DeltaSynchronizationConstDefs::DeltaSynchStatus.
         */
        const string DELTA_SYNCH_STATUS_FOR_ALARM_CMDDATA =
            DeltaSynchronizationConstDefs::AttributeNameValue::DELTA_SYNCH_STATUS_FOR_ALARM_DATA;
    };

    /* Constant definitions for the notifyNewDeltaSynchPoint notification */

    interface notifyNewDeltaSynchPoint: NotificationIRPNotifications::Notify
    {
        const string EVENT_TYPE = "notifyNewDeltaSynchPoint";

        /**
         * This constant defines the name of the AgentOrManagerReference property,
         * which is transported in the filterable_body fields.
         * The data type for the value of this property is
         * DeltaSynchronizationConstDefs::AgentOrManagerReference.
         */
        const string AGENT_OR_MANAGER_REFERENCE =
            DeltaSynchronizationConstDefs::AttributeNameValue::AGENT_OR_MANAGER_REFERENCE;

        /**
         * This constant defines the name of the NewDeltaSynchPoint property,
         * which is transported in the filterable_body fields.
         * The data type for the value of this property is

```

```
* DeltaSynchronizationConstDefs::SynchPoint.
*/
const string NEW_DELTA_SYNCH_POINT =
    DeltaSynchronizationConstDefs::AttributeNameValue::NEW_DELTA_SYNCH_POINT;

/**
 * This constant defines the name of the RequestedSynchPoint property,
 * which is transported in the filterable_body fields.
 * The data type for the value of this property is
 * DeltaSynchronizationConstDefs::SynchPoint.
 */
const string REQUESTED_SYNCH_POINT =
    DeltaSynchronizationConstDefs::AttributeNameValue::REQUESTED_SYNCH_POINT;

/**
 * This constant defines the name of the DeltaSynchPointType property,
 * which is transported in the filterable_body fields.
 * The data type for the value of this property is
 * DeltaSynchronizationConstDefs::DeltaSynchPointType.
 */
const string DELTA_SYNCH_POINT_TYPE =
    DeltaSynchronizationConstDefs::AttributeNameValue::DELTA_SYNCH_POINT_TYPE;

/**
 * This constant defines the name of the TriggeredByAgentOrManager property,
 * which is transported in the filterable_body fields.
 * The data type for the value of this property is
 * DeltaSynchronizationConstDefs::TriggeredBy.
 */
const string TRIGGERED_BY_AGENT_OR_MANAGER =
    DeltaSynchronizationConstDefs::AttributeNameValue::TRIGGERED_BY_AGENT_OR_MANAGER;

};

};

#endif // _DELTA_SYNCHRONIZATION_NOTIFICATIONS_IDL_
```

Annex B (normative): XML definitions

This annex contains the XML Definitions for the Delta Synchronisation IRP for the IRP whose semantics is specified in Delta Synchronisation IRP: Information Service (3GPP TS 32.392 [5]).

This XML Definitions specification defines the XML syntax of the Delta Synchronisation IRP XML Data File.

B.1 Architectural Features

The overall architectural feature of Delta Synchronisation IRP is specified in 3G TS 32.392 [5]. This clause specifies features that are specific to the XML definitions.

B.1.1 Syntax for Distinguished Names

The syntax of a Distinguished Name is defined in 3GPP TS 32.300 [21].

B.1.2 Notification Services

This annex defines the XML syntax of Delta Synchronisation IRP notifications that is to be used for the Delta Synchronisation IRP SOAP Solution Set and in conjunction with Notification Log IRP XML Definitions for Notification Log IRP XML Data File and the NL IRP XML Notification Format.

B.1.3 IOC definitions

This annex defines the XML syntax for the IOC definitions of the Delta Synchronisation IRP IS [5], which are used by the XML definitions for the Delta Synchronisation IRP notifications and the Delta Synchronisation IRP IS operations.

B.2 Mapping

Not present in the current version of this specification.

B.3 Solution Set definitions

B.3.1 XML definition structure

The present document defines the delta synchronizatiron-specific XML schema and element types in `deltaSynchForCMDData.xsd` / `deltaSynchForAlarms.xsd` which shall be used for the files of which the locations can be supplied as an option in output of operation `triggerDeltaSynchOfCMDData` or `triggerDeltaSynchOfAlarms` defined in 3GPP TS 32.392 [5].

The present schema re-uses the structure and content of 3GPP TS 32.616 [20] for delta synchronization for CM data and those of 3GPP TS 32.111-6 [19] for delta synchronization for alarm data. The differences or additions are listed here:

For delta synchronization for CM data:

The `modifier` XML attribute specification shall be used as follows:

- `Create` for all created NRM instances
- `Update` for all modified NRM instances
- `Delete` for all deleted NRM instances

For delta synchronization for alarm data:

- Created alarms shall be indicated by content XML elements of `type="xa:NotifyNewAlarm"`

- Changed alarms shall be indicated by content XML elements of type="xa:NotifyChangedAlarm" or of type="xa:NotifyClearedAlarm" or of type="xa:NotifyComments"

Deleted alarms shall be indicated by content XML elements of type="xa:NotifyAckStateChanged"

B.3.1.1 Global structure

See 3GPP TS 32.616 [20]

The following XML namespaces are potentially used in delta synchronisation XML files:

- delta synchronisation for CM data files are associated with XML schema deltaSynchForCMDData.xsd;
- delta synchronisation for alarm data files are associated with XML schema deltaSynchForAlarmData.xsd;

B.3.1.2 XML elements fileHeader and fileFooter

B.3.1.2.1 XML elements fileHeaderForDeltaSynchForCM/AlarmData

See 3GPP TS 32.616 [20]

The file header defined there is extended as follows (new parts marked by underlining>):
For delta synchronization of CM data:

```

<element name="fileHeaderDeltaSynchForCMDData">
  <complexType>
    <attribute name="fileFormatVersion" type="string" use="required"/>
    <attribute name="senderName" type="string" use="optional"/>
    <attribute name="vendorName" type="string" use="optional"/>
    <!-- The content of the following element is a copy of the original
         request/response parameters -->
    <element name="inAndOutputParameter" minOccurs="0" maxOccurs="1">
      <complexType>
        <sequence>
          <attribute name="managerReference" type="string" use="optional"/>
          <attribute name="dataRequested" type="dsa:AlarmDataRequested" use="required"/>
          <attribute name="startSynchronizationPoint" type="dateTime" use="required"/>
          <attribute name="newSynchronizationPoint" type="dateTime" use="required"/>
        </sequence>
      </complexType>
    </element>
  </complexType>
</element>
<element name="fileHeaderDeltaSynchForCMDData">
  <complexType>
    <sequence>
      <element name="fileHeader">
        <complexType>
          <attribute name="fileFormatVersion" type="string" use="required"/>
          <attribute name="senderName" type="string" use="optional"/>
          <attribute name="vendorName" type="string" use="optional"/>
        </complexType>
      </element>
      <!-- The content of the following element is a copy of the original
           request/response parameters -->
      <element name="inAndOutputParameter" minOccurs="0" maxOccurs="1">
        <complexType>
          <attribute name="dataRequested" type="dsc:CMDDataRequested" use="required"/>
          <attribute name="startSynchronizationPoint" type="dateTime" use="required"/>
          <attribute name="newSynchronizationPoint" type="dateTime" use="required"/>
          <attribute name="managerReference" type="string" use="optional"/>
        </complexType>
      </element>
      <element name="scope" type="nk:ScopeType" minOccurs="0"/>
    </sequence>
  </complexType>
</element>

```

For delta synchronization of alarm data:

```

<element name="fileHeaderDeltaSynchForCMDData">
  <complexType>
    <attribute name="fileFormatVersion" type="string" use="required"/>
    <attribute name="senderName" type="string" use="optional"/>
    <attribute name="vendorName" type="string" use="optional"/>
    <!-- The content of the following element is a copy of the original

```

```

    request/response parameters -->
<element name="inAndOutputParameter" minOccurs="0" maxOccurs="1">
  <complexType>
    <sequence>
      <attribute name="managerReference" type="string" use="optional"/>
      <attribute name="dataRequested" type="dsa:AlarmDataRequested" use="required"/>
      <attribute name="startSynchronizationPoint" type="dateTime" use="required"/>
      <attribute name="newSynchronizationPoint" type="dateTime" use="required"/>
    </sequence>
  </complexType>
</element>
</complexType>
</element>
<element name="fileHeaderDeltaSynchForAlarms">
  <complexType>
    <sequence>
      <element name="fileHeader">
        <complexType>
          <attribute name="fileFormatVersion" type="string" use="required"/>
          <attribute name="senderName" type="string" use="optional"/>
          <attribute name="vendorName" type="string" use="optional"/>
        </complexType>
      </element>
      <!-- The content of the following element is a copy of the original
           request/response parameters -->
      <element name="inAndOutputParameter" minOccurs="0" maxOccurs="1">
        <complexType>
          <attribute name="dataRequested" type="dsa:AlarmDataRequested" use="required"/>
          <attribute name="startSynchronizationPoint" type="dateTime" use="required"/>
          <attribute name="newSynchronizationPoint" type="dateTime" use="required"/>
          <attribute name="managerReference" type="string" use="optional"/>
        </complexType>
      </element>
      <element name="scope" type="nk:ScopeType" minOccurs="0"/>
    </sequence>
  </complexType>
</element>

```

B.3.1.2.2 XML element fileFooter

See 3GPP TS 32.616 [20]

B.3.1.3 Delta synchronisation IRP specific XML elements

For delta synchronization of CM data: Currently none, except those in clause Annex B.3.1.2.

For delta synchronization of alarm data:

```
<element name="deltaAlarm" type="dsa:DeltaAlarm maxOccurs="unbounded" />
```

of type

```
<complexType name="DeltaAlarm">  
  <choice>  
    <element ref="xa:NotifyNewAlarm" />  
    <element ref="xa:NotifyChangedAlarm" />  
    <element ref="xa:NotifyClearedAlarm" />  
    <element ref="xa:NotifyComments" />  
    <element ref="xa:NotifyAckStateChanged" />  
  </choice>  
</complexType>
```

B.3.1.4 Delta synchronisation IRP XML File Name Conventions

For NL IRP XML File Name Conventions the generic file name definitions as specified by the FT IRP apply (see [13])

B.3.2 Graphical Representation

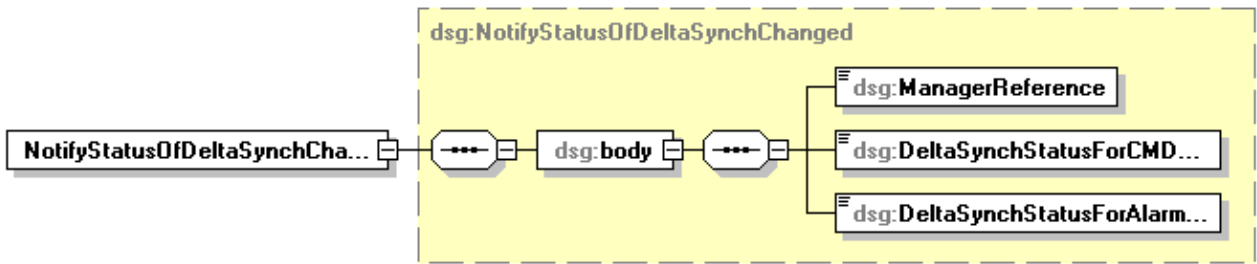

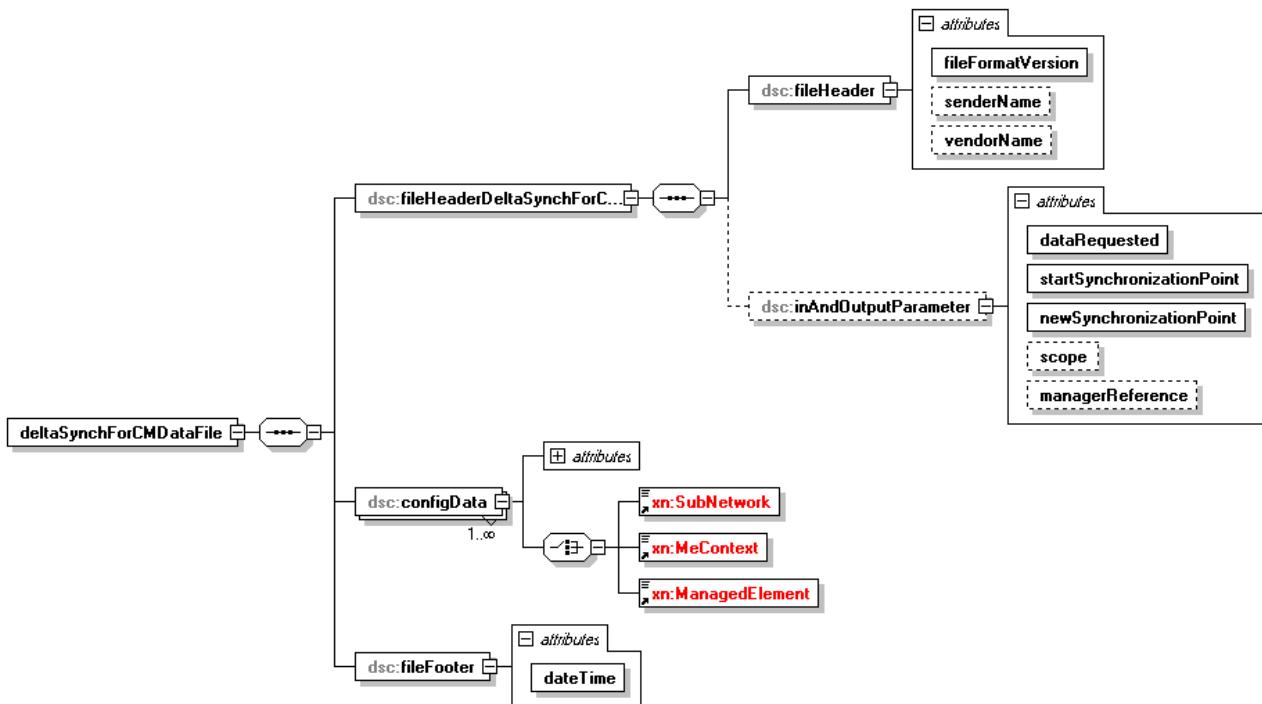
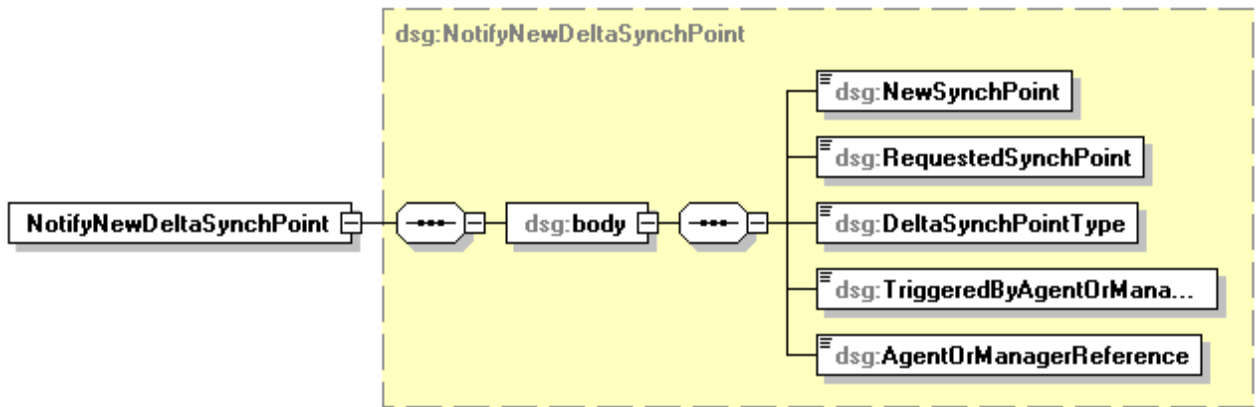

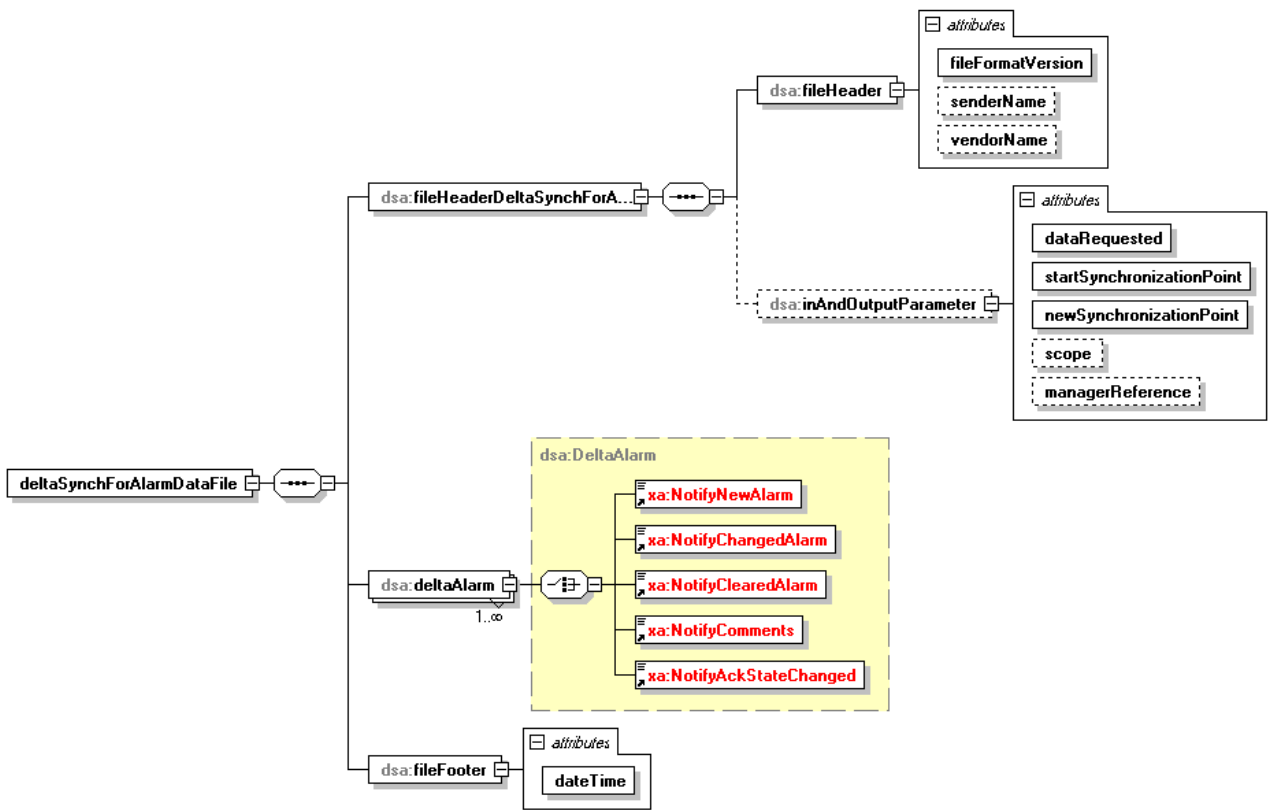

B.3.3 XML Schema

B.3.3.1 XML Schema "deltaSynchGeneric.xsd"

```

<?xml version="1.0" encoding="UTF-8"?>
<!--
  3GPP TS 32.396 Delta Synchronisation IRP
  Delta synchronization specific data file XML schemas
  deltaSynchGeneric.xsd
-->
<schema xmlns="http://www.w3.org/2001/XMLSchema"
  xmlns:dsg="http://www.3gpp.org/ftp/specs/archive/32_series/32.396#deltaSynchGeneric"
  xmlns:xe="http://www.3gpp.org/ftp/specs/archive/32_series/32.306#notification"
  targetNamespace="http://www.3gpp.org/ftp/specs/archive/32_series/32.396#deltaSynchGeneric"
  elementFormDefault="qualified">
  <import namespace="http://www.3gpp.org/ftp/specs/archive/32_series/32.306#notification"/>
  <!-- XML types specific for delta synchronization generic part -->
  <simpleType name="DeltaSynchStatus">
    <restriction base="string">
      <enumeration value="Activated"/>
      <enumeration value="Deactivated"/>
    </restriction>
  </simpleType>
  <complexType name="NotifyStatusOfDeltaSynchChanged">
    <complexContent>
      <extension base="xe:Notification">
        <sequence>
          <element name="body">
            <complexType>
              <sequence>
                <element name="ManagerReference" type="string"/>
                <element name="DeltaSynchStatusForCMDData"
type="dsg:DeltaSynchStatus"/>
                <element name="DeltaSynchStatusForAlarmData"
type="dsg:DeltaSynchStatus"/>
              </sequence>
            </complexType>
          </element>
        </sequence>
      </extension>
    </complexContent>
  </complexType>
  <element name="NotifyStatusOfDeltaSynchChanged" type="dsg:NotifyStatusOfDeltaSynchChanged"/>
  <simpleType name="DeltaSynchPointType">
    <restriction base="string">
      <enumeration value="DeltaSynchPointForAlarm"/>
      <enumeration value="DeltaSynchPointForCMDData"/>
    </restriction>
  </simpleType>
  <simpleType name="TriggeredByAgentOrManager">
    <restriction base="string">
      <enumeration value="IRPAgent"/>
      <enumeration value="IRPManager"/>
    </restriction>
  </simpleType>
  <complexType name="NotifyNewDeltaSynchPoint">
    <complexContent>
      <extension base="xe:Notification">
        <sequence>
          <element name="body">
            <complexType>
              <sequence>
                <element name="NewSynchPoint" type="dateTime"/>
                <element name="RequestedSynchPoint" type="dateTime"/>
                <element name="DeltaSynchPointType" type="dsg:DeltaSynchPointType"/>
                <element name="TriggeredByAgentOrManager"
type="dsg:TriggeredByAgentOrManager"/>
                <element name="AgentOrManagerReference" type="string"/>
              </sequence>
            </complexType>
          </element>
        </sequence>
      </extension>
    </complexContent>
  </complexType>
  <element name="NotifyNewDeltaSynchPoint" type="dsg:NotifyNewDeltaSynchPoint"/>
</schema>

```

B.3.3.2 XML Schema "deltaSynchForCMDData.xsd"

```

<?xml version="1.0" encoding="UTF-8"?>
<!--
3GPP TS 32.396 Delta Synchronisation IRP
Delta synchronization specific data file XML schemas for CM data XML schema
deltaSynchForCMDData.xsd
-->
<schema xmlns="http://www.w3.org/2001/XMLSchema"
xmlns:dsc="http://www.3gpp.org/ftp/specs/archive/32_series/32.396#deltaSynchForCMDData"
xmlns:xn="http://www.3gpp.org/ftp/specs/archive/32_series/32.626#genericNrm"
xmlns:nk="http://www.3gpp.org/ftp/specs/archive/32_series/32.666#kernelNtf"
targetNamespace="http://www.3gpp.org/ftp/specs/archive/32_series/32.396#deltaSynchForCMDData"
elementFormDefault="qualified">
  <import namespace="http://www.3gpp.org/ftp/specs/archive/32_series/32.626#genericNrm"/>
  <import namespace="http://www.3gpp.org/ftp/specs/archive/32_series/32.666#kernelNtf"/>
  <!-- XML types specific for delta synchronization of CM data -->
  <simpleType name="CMDDataRequested">
    <restriction base="string">
      <enumeration value="DNsOnly"/>
      <enumeration value="CompleteDataSet"/>
    </restriction>
  </simpleType>
  <!--Delta synchronization for CM data file root XML element -->
  <element name="deltaSynchForCMDDataFile">
    <complexType>
      <sequence>
        <element name="fileHeaderDeltaSynchForCMDData">
          <complexType>
            <sequence>
              <element name="fileHeader">
                <complexType>
                  <attribute name="fileFormatVersion" type="string"
use="required"/>
                  <attribute name="senderName" type="string" use="optional"/>
                  <attribute name="vendorName" type="string" use="optional"/>
                </complexType>
              </element>
              <!-- The content of the following element is a copy of the original
request/response parameters -->
              <element name="inAndOutputParameter" minOccurs="0">
                <complexType>
                  <attribute name="dataRequested" type="dsc:CMDDataRequested"
use="required"/>
                  <attribute name="startSynchronizationPoint" type="dateTime"
use="required"/>
                  <attribute name="newSynchronizationPoint" type="dateTime"
use="required"/>
                  <attribute name="managerReference" type="string"
use="optional"/>
                </complexType>
              </element>
              <element name="scope" type="nk:ScopeType" minOccurs="0"/>
            </sequence>
          </complexType>
        </element>
        <element name="configData" maxOccurs="unbounded">
          <complexType>
            <choice>
              <element ref="xn:SubNetwork"/>
              <element ref="xn:MeContext"/>
              <element ref="xn:ManagedElement"/>
            </choice>
            <attribute name="dnPrefix" type="string" use="optional"/>
          </complexType>
        </element>
        <element name="fileFooter">
          <complexType>
            <attribute name="dateTime" type="dateTime" use="required"/>
          </complexType>
        </element>
      </sequence>
    </complexType>
  </element>
</schema>

```

B.3.3.3 XML Schema "deltaSynchForAlarms.xsd"

```

<?xml version="1.0" encoding="UTF-8"?>
<!--
3GPP TS 32.396 Delta Synchronisation IRP
Delta synchronization specific data file XML schemas for alarm data XML schema
deltaSynchForAlarmData.xsd
-->
<schema xmlns="http://www.w3.org/2001/XMLSchema"
xmlns:dsa="http://www.3gpp.org/ftp/specs/archive/32_series/32.396#deltaSynchForAlarms"
xmlns:nk="http://www.3gpp.org/ftp/specs/archive/32_series/32.666#kernelNtf"
xmlns:xa="http://www.3gpp.org/ftp/specs/archive/32_series/32.111-6#alarmIRPNotif"
targetNamespace="http://www.3gpp.org/ftp/specs/archive/32_series/32.396#deltaSynchForAlarms"
elementFormDefault="qualified">
  <import namespace="http://www.3gpp.org/ftp/specs/archive/32_series/32.111-6#alarmIRPNotif"/>
  <import namespace="http://www.3gpp.org/ftp/specs/archive/32_series/32.666#kernelNtf"/>
  <!-- XML types specific for delta synchronization of alarm data -->
  <simpleType name="AlarmDataRequested">
    <restriction base="string">
      <enumeration value="AlarmIdsOnly"/>
      <enumeration value="CompleteAlarmInformation"/>
    </restriction>
  </simpleType>
  <complexType name="DeltaAlarm">
    <choice>
      <element ref="xa:NotifyNewAlarm"/>
      <element ref="xa:NotifyChangedAlarm"/>
      <element ref="xa:NotifyClearedAlarm"/>
      <element ref="xa:NotifyComments"/>
      <element ref="xa:NotifyAckStateChanged"/>
    </choice>
  </complexType>
  <!--Delta synchronization for alarm data file root XML element -->
  <element name="deltaSynchForAlarmDataFile">
    <complexType>
      <sequence>
        <element name="fileHeaderDeltaSynchForAlarms">
          <complexType>
            <sequence>
              <element name="fileHeader">
                <complexType>
                  <attribute name="fileFormatVersion" type="string"
use="required"/>
                  <attribute name="senderName" type="string" use="optional"/>
                  <attribute name="vendorName" type="string" use="optional"/>
                </complexType>
              </element>
              <!-- The content of the following element is a copy of the original
request/response parameters -->
              <element name="inAndOutputParameter" minOccurs="0">
                <complexType>
                  <attribute name="dataRequested" type="dsa:AlarmDataRequested"
use="required"/>
                  <attribute name="startSynchronizationPoint" type="dateTime"
use="required"/>
                  <attribute name="newSynchronizationPoint" type="dateTime"
use="required"/>
                  <attribute name="managerReference" type="string"
use="optional"/>
                </complexType>
              </element>
              <element name="scope" type="nk:ScopeType" minOccurs="0"/>
            </sequence>
          </complexType>
        </element>
        <element name="deltaAlarm" type="dsa:DeltaAlarm" maxOccurs="unbounded"/>
        <element name="fileFooter">
          <complexType>
            <attribute name="dateTime" type="dateTime" use="required"/>
          </complexType>
        </element>
      </sequence>
    </complexType>
  </element>
</schema>

```

Annex C (normative): SOAP Solution Set

This annex specifies the SOAP Solution Set for the IRP whose semantics are specified in Delta Synchronisation IRP: Information Service (3GPP TS 32.392 [5]).

C.1 Architectural features

The overall architectural feature of Delta Synchronisation IRP is specified in 3GPP TS 32.392 [5]. This clause specifies features that are specific to the SOAP solution set..

C.1.1 Syntax for Distinguished Names

The syntax of a Distinguished Name is defined in 3GPP TS 32.300[21].

C.1.2 Notification Services

Relevant definitions are imported from the Delta Synchronisation IRP XML definitions in Annex B.

C.1.3 Supported W3C specifications

The SOAP 1.1 specification [22] and WSDL 1.1 specification [24] are supported.

The SOAP 1.2 specification [25] is supported optionally.

This specification uses "document" style in WSDL file.

This specification uses "literal" encoding style in WSDL file.

The filter language used in the SS is the XPath Language (see W3C XPath 1.0 specification [23]). IRPAgents may throw a FilterComplexityLimit fault when a given filter is too complex.

Relevant definitions are imported from the Delta Synchronisation IRP XML definitions of Annex B

C.1.4 Prefixes and namespaces

This specification uses a number of namespace prefixes throughout that are listed in Table C.1.4..

Table C.1.4: Prefixes and Namespaces used in this specification

PREFIX	NAMESPACE
(no prefix)	http://schemas.xmlsoap.org/wsdl/
soap	http://schemas.xmlsoap.org/wsdl/soap/
deltaSynchIRPSyste m	http://www.3gpp.org/ftp/specs/archive/32_series/32.396#DeltaSynchIRPSystem
deltaSynchIRPData	http://www.3gpp.org/ftp/specs/archive/32_series/32.396#DeltaSynchIRPData
xn	http://www.3gpp.org/ftp/specs/archive/32_series/32.626#genericNrm
genericIRPSystem	http://www.3gpp.org/ftp/specs/archive/32_series/32.316#GenericIRPSystem
ntfIRPNtfSystem	http://www.3gpp.org/ftp/specs/archive/32_series/32.306#notification/NotificationIRPNtfSyste m

C.2 Mapping

C.2.1 Operation and notification mapping

The Delta Synchronisation IRP IS (3GPP TS 32.392 [5]) defines semantics of operation and notification visible across the Itf-N. Table C.2.1 indicates mapping of these operations and notifications to their equivalents defined in this SS.

Table C.2.1: Mapping from IS Operation to SS Equivalents

IS Operation / Notification (3GPP TS 32.392)	SS Method	SS Port	Qualifier
manageDeltaSynchronization	manageDeltaSynchronization	DeltaSynchGenericPartsPort	M
getAvailableDeltaSynchPoints	getAvailableDeltaSynchPoints	DeltaSynchGenericPartsPort	O
triggerDeltaSynchOfCMDData	triggerDeltaSynchOfCMDData	DeltaSynchOfCMDDataPort	O
triggerDeltaSynchOfAlarms	triggerDeltaSynchOfAlarms	DeltaSynchOfAlarmDataPort	O
notifyStatusOfDeltaSynchronization	notify (note 1)	NotificationIRPNtfPort	M
notifyNewDeltaSynchPoint	notify (note 1)	NotificationIRPNtfPort	O
NOTE 1: The IS equivalent maps to an XML definition specified in Annex B, and this being an input parameter to the operation notify under the port type ntfIRPNtfSystem:NotificationIRPNtf and under the binding ntfIRPNtfSystem:NotificationIRPNtf of 3GPP TS 32.306 [11].			

C.2.2 Operation parameter mapping

The Delta Synchronisation IRP IS (3GPP TS 32.392 [5]) defines semantics of parameters carried in the operations. The tables below show the mapping of these parameters, as per operation, to their equivalents defined in this SS.

Table C.2.2.1: Mapping from IS manageDeltaSynchronization parameters to SS equivalents

IS Operation parameter	SS Method parameter	Qualifier
managerReference	managerReference	M
manageDeltaSynchForAlarmData	manageDeltaSynchForAlarmData	CM
manageDeltaSynchForCMDData	manageDeltaSynchForCMDData	CM
status	status	M

Table C.2.2.2: Mapping from IS getAvailableDeltaSynchPoints parameters to SS equivalents

IS Operation parameter	SS Method parameter	Qualifier
managerReference	managerReference	O
synchPointsForCMDDataRequested	synchPointsForCMDDataRequested	CM
synchPointsForAlarmDataRequested	synchPointsForAlarmDataRequested	CM
synchPointListForAlarms	synchPointListForAlarms	CM
synchPointListForCMDData	synchPointListForCMDData	CM
status	status	M

Table C.2.2.3: Mapping from IS triggerDeltaSynchOfCMDData parameters to SS equivalents

IS Operation parameter	SS Method parameter	Qualifier
managerReference	managerReference	O
dataRequested	dataRequested	O
baseMOInstance	baseMOInstance	O
scope	scope	O
synchPoint	synchPoint	M
deltaLists	deltaLists	CM
newSynchPoint	newSynchPoint	CM
status	status	M

Table C.2.2.4: Mapping from IS triggerDeltaSynchOfAlarms parameters to SS equivalents

IS Operation parameter	SS Method parameter	Qualifier
managerReference	managerReference	M
dataRequested	dataRequested	M
baseMOInstance	baseMOInstance	O
scope	scope	O
synchPoint	synchPoint	M
deltaLists	deltaLists	CM
newSynchPoint	newSynchPoint	CM
status	status	M

C.2.3 Notification parameter mapping

The Delta Synchronisation IRP Notifications are defined in Annex B.

C.3 Solution Set definitions

C.3.1 WSDL definition structure

Clause C.3.2 provides a graphical representation of the Partial Suspension of Itf-N IRP service.

Clause C.3.3 defines the services which are supported the Partial Suspension of Itf-N IRP agent.

C.3.2 Graphical Representation

The WSDL structure is depicted in Figure C.3.2 below, depicting port type, binding and service. The port type contains port type operations, which again contains input, output and fault messages. The binding contains binding operations, which have the same name as the port type operations. The binding connects to a port inside the service.

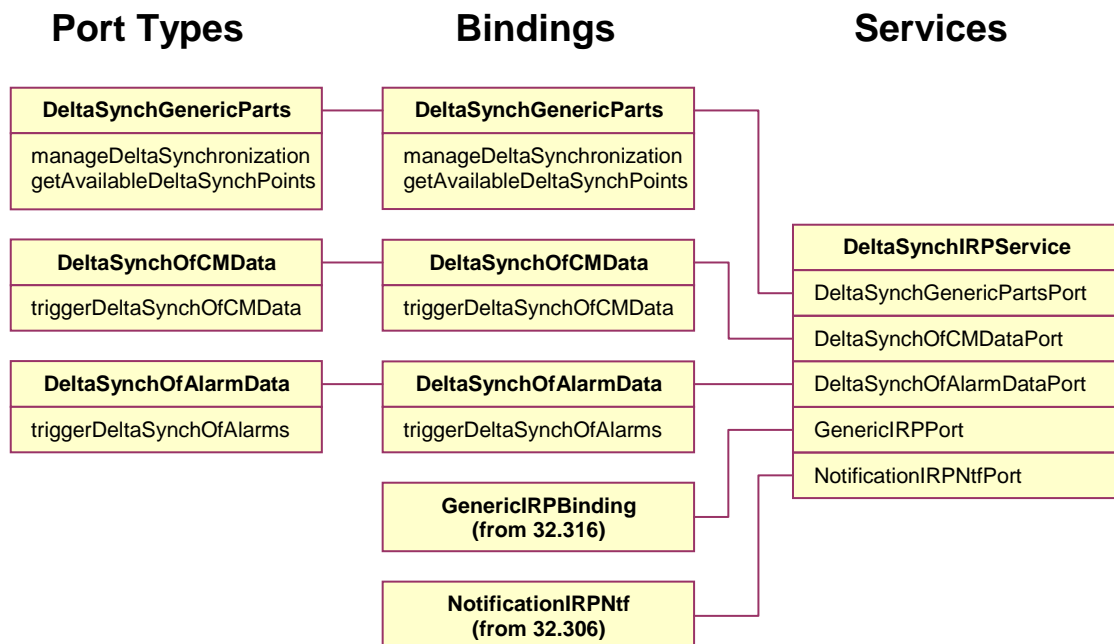

Figure C.3.2: Delta Synchronisation IRP SOAP Solution Set WSDL structure

C.3.3 WSDL specification "DeltaSynchIRPSystem.wsdl"

```

<?xml version="1.0" encoding="UTF-8"?>
<!--
3GPP TS 32.396 Delta Synchronization IRP SOAP Solution Set
-->
<definitions xmlns="http://schemas.xmlsoap.org/wsdl/"
xmlns:soap="http://schemas.xmlsoap.org/wsdl/soap/"
xmlns:deltaSynchIRPSystem="http://www.3gpp.org/ftp/specs/archive/32_series/32.396#DeltaSynchIRPSyste
m"
xmlns:deltaSynchIRPData="http://www.3gpp.org/ftp/specs/archive/32_series/32.396#DeltaSynchIRPData"
xmlns:xn="http://www.3gpp.org/ftp/specs/archive/32_series/32.626#genericNrm"
xmlns:genericIRPSystem="http://www.3gpp.org/ftp/specs/archive/32_series/32.316#GenericIRPSystem"
xmlns:ntfIRPntfSystem="http://www.3gpp.org/ftp/specs/archive/32_series/32.306#NotificationIRPntfSyst
em"
targetNamespace="http://www.3gpp.org/ftp/specs/archive/32_series/32.396#DeltaSynchIRPSystem">
  <import namespace="http://www.3gpp.org/ftp/specs/archive/32_series/32.316#GenericIRPSystem"/>
  <import
namespace="http://www.3gpp.org/ftp/specs/archive/32_series/32.306#NotificationIRPntfSystem"/>
  <types>
    <schema
targetNamespace="http://www.3gpp.org/ftp/specs/archive/32_series/32.396#DeltaSynchIRPData"
xmlns="http://www.w3.org/2001/XMLSchema"
xmlns:nk="http://www.3gpp.org/ftp/specs/archive/32_series/32.666#kernelNtf"
xmlns:xai="http://www.3gpp.org/ftp/specs/archive/32_series/32.111-6#alarmIRPIOCs">
      <!-- listOfInstances Type -->
      <complexType name="listOfInstances">
        <choice>
          <sequence minOccurs="0" maxOccurs="unbounded">
            <element name="MOInstance" type="xn:dn" minOccurs="0"/>
            <element name="attributeList" minOccurs="0">
              <complexType>
                <sequence maxOccurs="unbounded">
                  <element name="attributeName" type="string"/>
                  <element name="attributeValue" type="string" minOccurs="0"/>
                </sequence>
              </complexType>
            </element>
          </sequence>
          <sequence minOccurs="0" maxOccurs="unbounded">
            <element name="fileReference" type="xn:dn"/>
          </sequence>
        </choice>
      </complexType>
      <!-- listOfAlarms Type -->
      <complexType name="listOfAlarms">
        <choice>
          <sequence>
            <element name="alarmIdList">
              <complexType>
                <sequence minOccurs="0" maxOccurs="unbounded">
                  <element ref="xai:alarmId"/>
                </sequence>
              </complexType>
            </element>
          </sequence>
          <sequence>
            <element name="alarmInformationList">
              <complexType>
                <sequence minOccurs="0" maxOccurs="unbounded">
                  <choice>
                    <element name="nonSecurityAlarm" type="xai:NonSecurityAlarm"/>
                    <element name="securityAlarm" type="xai:SecurityAlarm"/>
                  </choice>
                </sequence>
              </complexType>
            </element>
          </sequence>
          <sequence minOccurs="0" maxOccurs="unbounded">
            <element name="fileReference" type="xn:dn"/>
          </sequence>
        </choice>
      </complexType>
      <!-- manageDeltaSynchronization Request -->
      <element name="manageDeltaSynchronizationRequest">
        <complexType>
          <sequence>

```

```

<element name="managerReference" type="string"/>
<element name="manageDeltaSynchForAlarmData" minOccurs="0">
  <simpleType>
    <restriction base="string">
      <enumeration value="Activate"/>
      <enumeration value="Deactivate"/>
    </restriction>
  </simpleType>
</element>
<element name="manageDeltaSynchForCMDData" minOccurs="0">
  <simpleType>
    <restriction base="string">
      <enumeration value="Activate"/>
      <enumeration value="Deactivate"/>
    </restriction>
  </simpleType>
</element>
</sequence>
</complexType>
</element>
<!-- manageDeltaSynchronization Response -->
<element name="manageDeltaSynchronizationResponse">
  <complexType>
    <sequence>
      <element name="status">
        <simpleType>
          <restriction base="string">
            <enumeration value="Success"/>
            <enumeration value="Failure"/>
          </restriction>
        </simpleType>
      </element>
      <element name="failureReason" minOccurs="0">
        <simpleType>
          <restriction base="string">
            <enumeration value="DeltaSynchNotSupportedForCMDData"/>
            <enumeration value="DeltaSynchNotSupportedForAlarmData"/>
            <enumeration value="operation_failed"/>
            <enumeration value="operation_failed_invalid_input_parameter"/>
            <enumeration value="operation_failed_internal_problem"/>
          </restriction>
        </simpleType>
      </element>
    </sequence>
  </complexType>
</element>
<!-- manageDeltaSynchronization Fault -->
<element name="manageDeltaSynchronizationFault">
  <simpleType>
    <restriction base="string">
      <enumeration value="OperationFailed"/>
    </restriction>
  </simpleType>
</element>
<!-- getAvailableDeltaSynchPoints Request -->
<element name="getAvailableDeltaSynchPointsRequest">
  <complexType>
    <sequence>
      <element name="managerReference" type="string" minOccurs="0"/>
      <element name="synchPointsForCMDDataRequested" minOccurs="0"/>
      <element name="synchPointsForAlarmDataRequested" minOccurs="0"/>
    </sequence>
  </complexType>
</element>
<!-- getAvailableDeltaSynchPoints Response -->
<element name="getAvailableDeltaSynchPointsResponse">
  <complexType>
    <sequence>
      <element name="synchPointListForAlarms" minOccurs="0">
        <complexType>
          <sequence minOccurs="0" maxOccurs="unbounded">
            <element name="synchPoint" type="dateTime"/>
          </sequence>
        </complexType>
      </element>
      <element name="synchPointListForCMDData" minOccurs="0">
        <complexType>
          <sequence minOccurs="0" maxOccurs="unbounded">

```

```

        <element name="synchPoint" type="dateTime"/>
    </sequence>
</complexType>
</element>
<element name="status">
    <simpleType>
        <restriction base="string">
            <enumeration value="Success"/>
            <enumeration value="Failure"/>
        </restriction>
    </simpleType>
</element>
<element name="failureReason" minOccurs="0">
    <simpleType>
        <restriction base="string">
            <enumeration value="DeltaSynchNotSupportedForCMDData"/>
            <enumeration value="DeltaSynchNotSupportedForAlarmData"/>
            <enumeration value="DeltaSynchNotActive"/>
            <enumeration value="DeltaSynchForCMDDataDeactivated"/>
            <enumeration value="DeltaSynchForAlarmDataDeactivated"/>
            <enumeration value="operation_failed"/>
            <enumeration value="operation_failed_invalid_input_parameter"/>
            <enumeration value="operation_failed_internal_problem"/>
        </restriction>
    </simpleType>
</element>
</sequence>
</complexType>
</element>
<!-- getAvailableDeltaSynchPoints Fault -->
<element name="getAvailableDeltaSynchPointsFault">
    <simpleType>
        <restriction base="string">
            <enumeration value="OperationFailed"/>
        </restriction>
    </simpleType>
</element>
<!-- triggerDeltaSynchOfCMDData Request -->
<element name="triggerDeltaSynchOfCMDDataRequest">
    <complexType>
        <sequence>
            <element name="managerReference" type="string" minOccurs="0"/>
            <element name="cmDataRequested">
                <simpleType>
                    <restriction base="string">
                        <enumeration value="DNsOnly"/>
                        <enumeration value="CompleteDataSet"/>
                    </restriction>
                </simpleType>
            </element>
            <element name="baseMOInstance" type="xn:dn" minOccurs="0"/>
            <element name="scope" type="nk:ScopeType" minOccurs="0"/>
            <element name="synchPoint" type="dateTime"/>
        </sequence>
    </complexType>
</element>
<!-- triggerDeltaSynchOfCMDData Response -->
<element name="triggerDeltaSynchOfCMDDataResponse">
    <complexType>
        <sequence>
            <element name="deltaLists" minOccurs="0">
                <complexType>
                    <sequence>
                        <element name="startTime" type="dateTime"/>
                        <element name="endTime" type="dateTime"/>
                        <element name="listOfCreatedInstances" type="deltaSynchIRPData:listOfInstances"/>
                        <element name="listOfChangedInstances" type="deltaSynchIRPData:listOfInstances"/>
                        <element name="listOfDeletedInstances" type="deltaSynchIRPData:listOfInstances"/>
                    </sequence>
                </complexType>
            </element>
            <element name="newSynchPoint" type="dateTime" minOccurs="0"/>
            <element name="status">
                <simpleType>
                    <restriction base="string">
                        <enumeration value="Success"/>
                        <enumeration value="Failure"/>
                    </restriction>
                </simpleType>
            </element>
        </sequence>
    </complexType>
</element>

```

```

    </simpleType>
  </element>
  <element name="failureReason" minOccurs="0">
    <simpleType>
      <restriction base="string">
        <enumeration value="SynchrPointTooLongAgo"/>
        <enumeration value="TooManyChangesFullSynchronizationRecommended"/>
        <enumeration value="SynchrPointUnknown"/>
        <enumeration value="DeltaSynchrNotSupportedForCMDData"/>
        <enumeration value="DeltaSynchrForCMDDataDeactivated"/>
        <enumeration value="operation_failed"/>
        <enumeration value="operation_failed_invalid_input_parameter"/>
        <enumeration
value="operation_failed_unsupported_optional_input_parameter_managerReference"/>
        <enumeration
value="operation_failed_unsupported_optional_input_parameter_baseMOInstance"/>
        <enumeration value="operation_failed_unsupported_optional_input_parameter_scope"/>
        <enumeration value="operation_failed_internal_problem"/>
      </restriction>
    </simpleType>
  </element>
</sequence>
</complexType>
</element>
<!-- triggerDeltaSynchrOfCMDData Fault -->
<element name="triggerDeltaSynchrOfCMDDataFault">
  <simpleType>
    <restriction base="string">
      <enumeration value="OperationFailed"/>
    </restriction>
  </simpleType>
</element>
<!-- triggerDeltaSynchrOfAlarms Request -->
<element name="triggerDeltaSynchrOfAlarmsRequest">
  <complexType>
    <sequence>
      <element name="managerReference" type="string" minOccurs="0"/>
      <element name="alarmDataRequested">
        <simpleType>
          <restriction base="string">
            <enumeration value="AlarmIdsOnly"/>
            <enumeration value="CompleteAlarmInformation"/>
          </restriction>
        </simpleType>
      </element>
      <element name="baseMOInstance" type="xn:dn" minOccurs="0"/>
      <element name="scope" type="nk:ScopeType" minOccurs="0"/>
      <element name="synchrPoint" type="dateTime"/>
    </sequence>
  </complexType>
</element>
<!-- triggerDeltaSynchrOfAlarms Response -->
<element name="triggerDeltaSynchrOfAlarmsResponse">
  <complexType>
    <sequence>
      <element name="deltaLists" minOccurs="0">
        <complexType>
          <sequence>
            <element name="startTime" type="dateTime"/>
            <element name="endTime" type="dateTime"/>
            <element name="listOfNewAlarms" type="deltaSynchrIRPData:listOfAlarms"/>
            <element name="listOfChangedAlarms" type="deltaSynchrIRPData:listOfAlarms"/>
            <element name="listOfDeletedAlarms" type="deltaSynchrIRPData:listOfAlarms"/>
          </sequence>
        </complexType>
      </element>
      <element name="newSynchrPoint" type="dateTime"/>
      <element name="status">
        <simpleType>
          <restriction base="string">
            <enumeration value="Success"/>
            <enumeration value="Failure"/>
          </restriction>
        </simpleType>
      </element>
      <element name="failureReason" minOccurs="0">
        <simpleType>
          <restriction base="string">

```

```

        <enumeration value="SynchrPointTooLongAgo" />
        <enumeration value="TooManyChangesFullSynchronizationRecommended" />
        <enumeration value="SynchrPointUnknown" />
        <enumeration value="DeltaSynchNotSupportedForAlarmData" />
        <enumeration value="DeltaSynchForAlarmsNotActive" />
        <enumeration value="operation_failed" />
        <enumeration value="operation_failed_invalid_input_parameter" />
        <enumeration
value="operation_failed_unsupported_optional_input_parameter_managerReference" />
        <enumeration
value="operation_failed_unsupported_optional_input_parameter_baseMOInstance" />
        <enumeration value="operation_failed_unsupported_optional_input_parameter_scope" />
        <enumeration value="operation_failed_internal_problem" />
    </restriction>
</simpleType>
</element>
</sequence>
</complexType>
</element>
<!-- triggerDeltaSynchOfAlarms Fault -->
<element name="triggerDeltaSynchOfAlarmsFault">
    <simpleType>
        <restriction base="string">
            <enumeration value="OperationFailed" />
        </restriction>
    </simpleType>
</element>
</schema>
</types>
<message name="manageDeltaSynchronizationRequest">
    <part name="parameter" element="deltaSynchIRPData:manageDeltaSynchronizationRequest" />
</message>
<message name="manageDeltaSynchronizationResponse">
    <part name="parameter" element="deltaSynchIRPData:manageDeltaSynchronizationResponse" />
</message>
<message name="manageDeltaSynchronizationFault">
    <part name="parameter" element="deltaSynchIRPData:manageDeltaSynchronizationFault" />
</message>
<message name="getAvailableDeltaSynchPointsRequest">
    <part name="parameter" element="deltaSynchIRPData:getAvailableDeltaSynchPointsRequest" />
</message>
<message name="getAvailableDeltaSynchPointsResponse">
    <part name="parameter" element="deltaSynchIRPData:getAvailableDeltaSynchPointsResponse" />
</message>
<message name="getAvailableDeltaSynchPointsFault">
    <part name="parameter" element="deltaSynchIRPData:getAvailableDeltaSynchPointsFault" />
</message>
<message name="triggerDeltaSynchOfCMDDataRequest">
    <part name="parameter" element="deltaSynchIRPData:triggerDeltaSynchOfCMDDataRequest" />
</message>
<message name="triggerDeltaSynchOfCMDDataResponse">
    <part name="parameter" element="deltaSynchIRPData:triggerDeltaSynchOfCMDDataResponse" />
</message>
<message name="triggerDeltaSynchOfCMDDataFault">
    <part name="parameter" element="deltaSynchIRPData:triggerDeltaSynchOfCMDDataFault" />
</message>
<message name="triggerDeltaSynchOfAlarmsRequest">
    <part name="parameter" element="deltaSynchIRPData:triggerDeltaSynchOfAlarmsRequest" />
</message>
<message name="triggerDeltaSynchOfAlarmsResponse">
    <part name="parameter" element="deltaSynchIRPData:triggerDeltaSynchOfAlarmsResponse" />
</message>
<message name="triggerDeltaSynchOfAlarmsFault">
    <part name="parameter" element="deltaSynchIRPData:triggerDeltaSynchOfAlarmsFault" />
</message>
<portType name="DeltaSynchGenericParts">
    <operation name="manageDeltaSynchronization">
        <input message="deltaSynchIRPSystem:manageDeltaSynchronizationRequest" />
        <output message="deltaSynchIRPSystem:manageDeltaSynchronizationResponse" />
        <fault name="manageDeltaSynchronizationFault"
message="deltaSynchIRPSystem:manageDeltaSynchronizationFault" />
    </operation>
    <operation name="getAvailableDeltaSynchPoints">
        <input message="deltaSynchIRPSystem:getAvailableDeltaSynchPointsRequest" />
        <output message="deltaSynchIRPSystem:getAvailableDeltaSynchPointsResponse" />
        <fault name="getAvailableDeltaSynchPointsFault "
message="deltaSynchIRPSystem:getAvailableDeltaSynchPointsFault" />
    </operation>

```

```

</portType>
<portType name="DeltaSynchOfCMDData">
  <operation name="triggerDeltaSynchOfCMDData">
    <input message="deltaSynchIRPSystem:triggerDeltaSynchOfCMDDataRequest"/>
    <output message="deltaSynchIRPSystem:triggerDeltaSynchOfCMDDataResponse"/>
    <fault name="triggerDeltaSynchOfCMDDataFault"
message="deltaSynchIRPSystem:triggerDeltaSynchOfCMDDataFault"/>
  </operation>
</portType>
<portType name="DeltaSynchOfAlarmData">
  <operation name="triggerDeltaSynchOfAlarms">
    <input message="deltaSynchIRPSystem:triggerDeltaSynchOfAlarmsRequest"/>
    <output message="deltaSynchIRPSystem:triggerDeltaSynchOfAlarmsResponse"/>
    <fault name="triggerDeltaSynchOfAlarmsFault"
message="deltaSynchIRPSystem:triggerDeltaSynchOfAlarmsFault"/>
  </operation>
</portType>
<binding name="DeltaSynchGenericParts" type="deltaSynchIRPSystem:DeltaSynchGenericParts">
  <soap:binding style="document" transport="http://schemas.xmlsoap.org/soap/http"/>
  <operation name="manageDeltaSynchronization">
    <soap:operation
soapAction="http://www.3gpp.org/ftp/specs/archive/32_series/32.396#manageDeltaSynchronization"
style="document"/>
    <input>
      <soap:body use="literal"/>
    </input>
    <output>
      <soap:body use="literal"/>
    </output>
    <fault name="manageDeltaSynchronizationFault">
      <soap:fault name="manageDeltaSynchronizationFault" use="literal"/>
    </fault>
  </operation>
  <operation name="getAvailableDeltaSynchPoints">
    <soap:operation
soapAction="http://www.3gpp.org/ftp/specs/archive/32_series/32.396#getAvailableDeltaSynchPoints"
style="document"/>
    <input>
      <soap:body use="literal"/>
    </input>
    <output>
      <soap:body use="literal"/>
    </output>
    <fault name="getAvailableDeltaSynchPointsFault">
      <soap:fault name="getAvailableDeltaSynchPointsFault" use="literal"/>
    </fault>
  </operation>
</binding>
<binding name="DeltaSynchOfCMDData" type="deltaSynchIRPSystem:DeltaSynchOfCMDData">
  <soap:binding style="document" transport="http://schemas.xmlsoap.org/soap/http"/>
  <operation name="triggerDeltaSynchOfCMDData">
    <soap:operation
soapAction="http://www.3gpp.org/ftp/specs/archive/32_series/32.396#triggerDeltaSynchOfCMDData"
style="document"/>
    <input>
      <soap:body use="literal"/>
    </input>
    <output>
      <soap:body use="literal"/>
    </output>
    <fault name="triggerDeltaSynchOfCMDDataFault">
      <soap:fault name="triggerDeltaSynchOfCMDDataFault" use="literal"/>
    </fault>
  </operation>
</binding>
<binding name="DeltaSynchOfAlarmData" type="deltaSynchIRPSystem:DeltaSynchOfAlarmData">
  <soap:binding style="document" transport="http://schemas.xmlsoap.org/soap/http"/>
  <operation name="triggerDeltaSynchOfAlarms">
    <soap:operation
soapAction="http://www.3gpp.org/ftp/specs/archive/32_series/32.396#triggerDeltaSynchOfAlarms"
style="document"/>
    <input>
      <soap:body use="literal"/>
    </input>
    <output>
      <soap:body use="literal"/>
    </output>
    <fault name="triggerDeltaSynchOfAlarmsFault">

```



```
        <soap:fault name="triggerDeltaSynchOfAlarmsFault" use="literal"/>
      </fault>
    </operation>
  </binding>
  <service name="DeltaSynchIRPService">
    <port name="DeltaSynchGenericPartsPort" binding="deltaSynchIRPSystem:DeltaSynchGenericParts">
      <soap:address
location="http://www.3gpp.org/ftp/specs/archive/32_series/32.396#DeltaSynchGenericParts"/>
    </port>
    <port name="DeltaSynchOfCMDDataPort" binding="deltaSynchIRPSystem:DeltaSynchOfCMDData">
      <soap:address
location="http://www.3gpp.org/ftp/specs/archive/32_series/32.396#DeltaSynchOfCMDData"/>
    </port>
    <port name="DeltaSynchOfAlarmDataPort" binding="deltaSynchIRPSystem:DeltaSynchOfAlarmData">
      <soap:address
location="http://www.3gpp.org/ftp/specs/archive/32_series/32.396#DeltaSynchOfAlarmData"/>
    </port>
    <port name="GenericIRPPort" binding="genericIRPSystem:GenericIRPBinding">
      <soap:address location="http://www.3gpp.org/ftp/specs/archive/32_series/32.316#GenericIRP"/>
    </port>
    <port name="NotificationIRPNtfPort" binding="ntfIRPNtfSystem:NotificationIRPNtf">
      <soap:address
location="http://www.3gpp.org/ftp/specs/archive/32_series/32.306#NotificationIRPNtf"/>
    </port>
  </service>
</definitions>
```

Annex D (informative): Change history

Change history							
Date	Meeting	TDoc	CR	Rev	Cat	Subject/Comment	New version
2010-09	SA#49	SP-100507	--	--		Presentation to SA for Information and Approval	1.0.0
2010-10	--	--	--	--		Publication	10.0.0
2010-12	SA#50	SP-100831	001	1		Correcting IDL syntax errors	10.1.0
2011-12	SA#54	SP-110717	002	2		Correct syntax errors in XML schemas and WSDL	10.2.0
2012-09	SA#57	-	-	-		Automatic upgrade from previous Release version 10.2.0	11.0.0
2014-09	SA#65	SP-140559	003	-		Update the link from Solution Set to Information Service due to the end of Release 12	12.0.0
2016-01	-	-	-	-		Update to Rel-13 version (MCC)	13.0.0
2016-06	SA#72	SP-160407	0004	-	F	Update the link from IRP Solution Set to IRP Information Service	13.1.0
2017-03	SA#75	-	-	-		Promotion to Release 14 without technical change	14.0.0
2017-06	SA#76	SP-170502	0005	-	F	Update the link from IRP Solution Set to IRP Information Service	14.1.0
2018-06	-	-	-	-	-	Update to Rel-15 version (MCC)	15.0.0

History

Document history		
V15.0.0	July 2018	Publication