

ETSI TS 132 423 V10.10.0 (2020-08)



**Digital cellular telecommunications system (Phase 2+) (GSM);
Universal Mobile Telecommunications System (UMTS);
LTE;
Telecommunication management;
Subscriber and equipment trace;
Trace data definition and management
(3GPP TS 32.423 version 10.10.0 Release 10)**



Reference

RTS/TSGS-0532423vaa0

Keywords

GSM,LTE,UMTS

ETSI

650 Route des Lucioles
F-06921 Sophia Antipolis Cedex - FRANCE

Tel.: +33 4 92 94 42 00 Fax: +33 4 93 65 47 16

Siret N° 348 623 562 00017 - NAF 742 C
Association à but non lucratif enregistrée à la
Sous-Préfecture de Grasse (06) N° 7803/88

Important notice

The present document can be downloaded from:

<http://www.etsi.org/standards-search>

The present document may be made available in electronic versions and/or in print. The content of any electronic and/or print versions of the present document shall not be modified without the prior written authorization of ETSI. In case of any existing or perceived difference in contents between such versions and/or in print, the prevailing version of an ETSI deliverable is the one made publicly available in PDF format at www.etsi.org/deliver.

Users of the present document should be aware that the document may be subject to revision or change of status.

Information on the current status of this and other ETSI documents is available at

<https://portal.etsi.org/TB/ETSIDeliverableStatus.aspx>

If you find errors in the present document, please send your comment to one of the following services:

<https://portal.etsi.org/People/CommitteeSupportStaff.aspx>

Copyright Notification

No part may be reproduced or utilized in any form or by any means, electronic or mechanical, including photocopying and microfilm except as authorized by written permission of ETSI.

The content of the PDF version shall not be modified without the written authorization of ETSI.

The copyright and the foregoing restriction extend to reproduction in all media.

© ETSI 2020.

All rights reserved.

DECT™, **PLUGTESTS™**, **UMTS™** and the ETSI logo are trademarks of ETSI registered for the benefit of its Members.

3GPP™ and **LTE™** are trademarks of ETSI registered for the benefit of its Members and of the 3GPP Organizational Partners.

oneM2M™ logo is a trademark of ETSI registered for the benefit of its Members and of the oneM2M Partners.

GSM® and the GSM logo are trademarks registered and owned by the GSM Association.

Intellectual Property Rights

Essential patents

IPRs essential or potentially essential to normative deliverables may have been declared to ETSI. The information pertaining to these essential IPRs, if any, is publicly available for **ETSI members and non-members**, and can be found in ETSI SR 000 314: *"Intellectual Property Rights (IPRs); Essential, or potentially Essential, IPRs notified to ETSI in respect of ETSI standards"*, which is available from the ETSI Secretariat. Latest updates are available on the ETSI Web server (<https://ipr.etsi.org/>).

Pursuant to the ETSI IPR Policy, no investigation, including IPR searches, has been carried out by ETSI. No guarantee can be given as to the existence of other IPRs not referenced in ETSI SR 000 314 (or the updates on the ETSI Web server) which are, or may be, or may become, essential to the present document.

Trademarks

The present document may include trademarks and/or tradenames which are asserted and/or registered by their owners. ETSI claims no ownership of these except for any which are indicated as being the property of ETSI, and conveys no right to use or reproduce any trademark and/or tradename. Mention of those trademarks in the present document does not constitute an endorsement by ETSI of products, services or organizations associated with those trademarks.

Legal Notice

This Technical Specification (TS) has been produced by ETSI 3rd Generation Partnership Project (3GPP).

The present document may refer to technical specifications or reports using their 3GPP identities. These shall be interpreted as being references to the corresponding ETSI deliverables.

The cross reference between 3GPP and ETSI identities can be found under <http://webapp.etsi.org/key/queryform.asp>.

Modal verbs terminology

In the present document "**shall**", "**shall not**", "**should**", "**should not**", "**may**", "**need not**", "**will**", "**will not**", "**can**" and "**cannot**" are to be interpreted as described in clause 3.2 of the [ETSI Drafting Rules](#) (Verbal forms for the expression of provisions).

"**must**" and "**must not**" are **NOT** allowed in ETSI deliverables except when used in direct citation.

Contents

Intellectual Property Rights	2
Legal Notice	2
Modal verbs terminology.....	2
Foreword.....	5
Introduction	5
1 Scope	6
2 References	6
3 Definitions, symbols and abbreviations	7
3.1 Definitions	7
3.2 Symbols.....	8
3.3 Abbreviations	8
4 Trace Record Contents	9
4.1 General	9
4.2 MSC Server Trace Record Content	10
4.3 MGW Trace Record Content.....	17
4.4 SGSN Trace Record Content.....	18
4.5 GGSN Trace Record Content.....	27
4.6 UTRAN Trace Record Content	31
4.7 Void.....	38
4.8 Void.....	38
4.9 HSS Trace Record Content	39
4.10 BM-SC Trace Record Content	43
4.11 PGW Trace Record Content	44
4.12 MME Trace Record Content	49
4.13 E-UTRAN Trace Record Content	58
4.14 SGW Trace Record Content.....	62
4.15 EIR Trace Record Content	67
Annex A (normative): Trace Report File Format	68
A.1 Parameter description and mapping table.....	69
A.2 XML file format definition.....	72
A.2.1 XML trace/MDT file diagram	72
A.2.2 Trace data file XML schema	73
Annex B (normative): Trace Report File Conventions and Transfer Procedure.....	76
B.1 File naming convention.....	76
B.2 File transfer	77
Annex C (informative): Trace Functional Architecture: Reporting.....	78
C.1 Figure of Trace Reporting	78
Annex D (informative): Examples of trace files.....	80
D.1 Examples of trace XML file	80
D.1.1 Example of XML trace file with the maximum level of details	80
D.1.2 Example of XML trace file with the minimum level of details	81
D.1.3 Example of XML trace file for IMSI information from the MME	81
D.1.4 Example of MDT XML file	82
Annex E (informative): Void	83

Annex F (informative): **Change history**84
History85

Foreword

This Technical Specification has been produced by the 3rd Generation Partnership Project (3GPP).

The contents of the present document are subject to continuing work within the TSG and may change following formal TSG approval. Should the TSG modify the contents of the present document, it will be re-released by the TSG with an identifying change of release date and an increase in version number as follows:

Version x.y.z

where:

- x the first digit:
 - 1 presented to TSG for information;
 - 2 presented to TSG for approval;
 - 3 or greater indicates TSG approved document under change control.
- y the second digit is incremented for all changes of substance, i.e. technical enhancements, corrections, updates, etc.
- z the third digit is incremented when editorial only changes have been incorporated in the document.

Introduction

The present document is part of a TS-family covering the 3rd Generation Partnership Project; Technical Specification Group Services and System Aspects; Telecommunication management, as identified below:

TS 32.421: "Subscriber and equipment trace; Trace concepts and requirements";

TS 32.422: "Subscriber and equipment trace; Trace control and configuration management";

TS 32.423: "Subscriber and equipment trace; Trace data definition and management";

Subscriber and MS Trace provide very detailed information at call level on one or more specific mobile(s). This data is an additional source of information to Performance Measurements and allows going further in monitoring and optimisation operations.

Contrary to Performance Measurements, which are a permanent source of information, Trace is activated on user demand for a limited period of time for specific analysis purpose

Trace plays a major role in activities such as determination of the root cause of a malfunctioning mobile, advanced troubleshooting, optimisation of resource usage and quality, RF coverage control and capacity improvement, dropped call analysis, Core Network and UTRAN end to end 3G procedure validation.

The capability to log data on any interface at call level for a specific user (e.g. IMSI) or mobile type (e.g. IMEI or IMEISV) allows getting information which cannot be deduced from Performance Measurements such as perception of end-user QoS during his call (e.g. requested QoS vs. provided QoS), correlation between protocol messages and RF measurements, or interoperability with specific mobile vendors.

Moreover, Performance Measurements provide values aggregated on an observation period, Subscriber and Equipment Trace give instantaneous values for a specific event (e.g. call, location update, etc.).

If Performance Measurements are mandatory for daily operations, future network planning and primary trouble shooting, Subscriber and MS Trace is the easy way to go deeper into investigation and 3G network optimisation.

In order to produce this data, Subscriber and MS trace are carried out in the NEs, which comprise the network. The data can then be transferred to an external system (e.g. an Operations System (OS) in TMN terminology, for further evaluation).

1 Scope

The present document describes Trace data definition and management. It covers the trace records content, their format and transfer.

The objectives of the present document are:

- To provide the descriptions for a standard set of Trace data;
- To define the common format of trace records; and
- To define a method for Trace results reporting across the management interfaces.

Clause 4 details the various Trace records content, Annex A provides Trace report file format, Annex B provides the trace report file conventions and transfer procedure, Annex C provides the trace reporting functional architecture and Annex D provides some trace files examples. Trace concepts and requirements are covered in TS 32.421 [2] while Trace control and configuration management are described in 3GPP TS 32.422 [3].

The definition of Trace data is intended to result in comparability of Trace data produced in a multi-vendor wireless UMTS and/or EPS network.

The following is beyond the scope of the present document, and therefore the present document does not describe:

- Any notification mechanisms or IRPs for trace. Only file transfer mechanism is specified for trace data transfer;
- Any data compression mechanisms for trace data transfer;
- Any Trace capability limitations (e.g. maximum number of simultaneous traced mobiles for a given NE).

2 References

The following documents contain provisions, which, through reference in this text, constitute provisions of the present document.

- References are either specific (identified by date of publication, edition number, version number, etc.) or non-specific.
- For a specific reference, subsequent revisions do not apply.
- For a non-specific reference, the latest version applies. In the case of a reference to a 3GPP document (including a GSM document), a non-specific reference implicitly refers to the latest version of that document *in the same Release as the present document*.

- [1] 3GPP TS 32.101: "Telecommunication management; Principles and high level requirements".
- [2] 3GPP TS 32.421: "Telecommunication management; Subscriber and equipment trace: Trace concepts and requirements."
- [3] 3GPP TS 32.422: "Telecommunication management; Subscriber and equipment trace: Trace control and configuration management".
- [4] 3GPP TR 21.905: "Vocabulary for 3GPP Specifications".
- [5] W3C Recommendation "Extensible Markup Language (XML) 1.0" (Second Edition, 6 October 2000) <http://www.w3.org/TR/2000/REC-xml-20001006>
- [6] W3C Recommendation "Namespaces in XML" (14 January 1999) <http://www.w3.org/TR/1999/REC-xml-names-19990114>
- [7] W3C Recommendation "XML Schema Part 0: Primer" (2 May 2001) <http://www.w3.org/TR/2001/REC-xmlschema-0-20010502>
- [8] W3C Recommendation "XML Schema Part 1: Structures" (2 May 2001) <http://www.w3.org/TR/2001/REC-xmlschema-1-20010502>

- [9] W3C Recommendation "XML Schema Part 2: Datatypes" (2 May 2001)
<http://www.w3.org/TR/2001/REC-xmlschema-2-20010502>
- [10] International Standard ISO 8601: 1988 (E) "Representations of dates and times" (1988-06-15)
<http://www.iso.ch/markete/8601.pdf>
- [11] 3GPP TS 32.300: "Telecommunication management; Configuration Management (CM); Name convention for Managed Objects".
- [12] 3GPP TS 32.622: "Telecommunication management; Configuration Management (CM); Generic network resources Integration Reference Point (IRP): Network Resource Model (NRM)".
- [13] 3GPP TS 29.274: "3GPP Evolved Packet System (EPS); Evolved General Packet Radio Service (GPRS) Tunnelling Protocol for Control plane (GTPv2-C); Stage 3"
- [14] 3GPP TS 29.212: "Policy and Charging Control over Gx reference point"
- [15] 3GPP TS 29.273: "Evolved Packet System (EPS); 3GPP EPS AAA interfaces"

3 Definitions, symbols and abbreviations

3.1 Definitions

For the purposes of the present document, the terms and definitions given in 3GPP TS 32.421 [2] and 3GPP TS 32.422 [3] apply.







Minimum Level of detail: Allows for retrieval of a decoded subset of the IEs contained in the signalling interface messages.

Medium Level of detail: Allows for retrieval of the decoded subset of the IEs contained in the signalling interface messages in the Minimum Level plus a selected set of decoded radio measurement IEs.

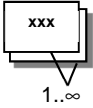
Maximum Level of detail: Allows for retrieval of signalling interface messages within the Trace Scope in encoded format.

3.2 Symbols

For the purposes of the present document, the following symbols apply:

	: Element named xxx The maximum number of occurrence is 1
	: Element named xxx The maximum number of occurrence is unbounded
	: Global element
	The XML element has a value part
	: Required element
	: Optional element
	: Sequence
	: Choice

3.3 Abbreviations

For the purposes of the present document, the abbreviations given in 3GPP TR 21.905 [4] and 3GPP TS 32.101 [1] apply.

4 Trace Record Contents

4.1 General

The trace reference, trace type and operation system identification are all provided on trace activation.

Each record may contain an MSC Server, MGW, SGSN, GGSN, S-CSCF, P-CSCF, UTRAN, HSS, MME, Serving GW, or E-UTRAN event record. A key is included in the table indicating whether or not the field is mandatory.

The following table shows the template for trace record description for minimum and medium trace depth:

Interface name	Protocol name	IE name	Message name(s)	Trace depth		Notes
				Min	Med	

Interface name: Contains the name of the interface, where the IE is available.

Protocol name: Contains the protocol name on the interface, where the IE is available.

IE name: The name of the Information Element, which should be decoded.

Message name(s): The name of the message(s), where the IE is included.

Trace depth: Shows in which trace depth the IE should be recorded. It also classifies whether the IE is mandatory in the trace record or not (M, O or X: meaning described in the previous table)

M	Mandatory	This field must be in the trace record if it is available, i.e. if the message appears during the trace recording session and the IE is present in the message.
O	Optional	This field is optional and its support is a matter for agreement between equipment manufacturer and network operator.
X	Not applicable	This field is not required in this instance.
CM	Conditional Mandatory	This field must be in the trace record if it is available and the condition is met.

NOTE: Any kind of comments related to the IE can be made here. Also this is the placeholder for referencing the relevant 3GPP specifications, which define the IE.

4.2 MSC Server Trace Record Content

The following table shows the trace record content for MSC Server.
The trace record is the same for management based activation and for signalling based activation.
For MSC Server, the Minimum level of detail shall be supported.

Interface name	Prot. name	IE name	Message name(s)	Trace depth		Notes
				Min	Med	
lu, A	CC	Facility	ALERTING CALL PROCEEDING CONNECT DISCONNECT FACILITY RELEASE RELEASE COMPLETE SETUP	M	M	TS 24.008 TS 24.080
		Bearer capability	CALL CONFIRMED CALL PROCEEDING EMERGENCY SETUP MODIFY MODIFY COMPLETE MODIFY REJECT SETUP	M	M	TS 24.008
		Cause	CALL CONFIRMED CONGESTION CONTROL DISCONNECT HOLD REJECT MODIFY REJECT RELEASE RELEASE COMPLETE RETRIEVE REJECT START DTMF REJECT STATUS	M	M	TS 24.008
		Connected number	CONNECT	M	M	TS 24.008
		Calling party BCD number	SETUP	M	M	TS 24.008
		Called party BCD number	SETUP	M	M	TS 24.008
		Redirecting party BCD number	SETUP	M	M	TS 24.008
lu, A	MM	Reject cause	AUTHENTICATION FAILURE CM SERVICE REJECT ABORT LOCATION UPDATING REJECT MM STATUS	M	M	TS 24.008
		Location area identification	CM RE-ESTABLISHMENT REQUEST LOCATION UPDATING ACCEPT LOCATION UPDATING REQUEST TMSI REALLOCATION COMMAND	M	M	TS 24.008
		Mobile identity	CM RE-ESTABLISHMENT REQUEST CM SERVICE REQUEST IDENTITY REQUEST IDENTITY RESPONSE IMSI DETACH INDICATION LOCATION UPDATING ACCEPT LOCATION UPDATING REQUEST TMSI REALLOCATION COMMAND	M	M	TS 24.008
		CM service type	CM SERVICE REQUEST	M	M	TS 24.008
		Location updating type	LOCATION UPDATING REQUEST	M	M	TS 24.008
		Facility	FACILITY REGISTER RELEASE COMPLETE	M	M	TS 24.008

		Cause	RELEASE COMPLETE	M	M	TS 24.008
Iu, A	SMS	TP-Originating-Address	SMS-DELIVER	M	M	TS 23.040
		TP-Service-Centre- Time-Stamp	SMS-DELIVER SMS-SUBMIT-REPORT SMS-STATUS-REPORT	M	M	TS 23.040
		TP-Failure-Cause	SMS-DELIVER-REPORT SMS-SUBMIT-REPORT	M	M	TS 23.040
		TP-Destination-Address	SMS-SUBMIT SMS-COMMAND	M	M	TS 23.040
		TP-Recipient-Address	SMS-STATUS-REPORT	M	M	TS 23.040
		A	BSSMAP	Channel Type	ASSIGNMENT REQUEST HANDOVER REQUEST	M
Circuit	ASSIGNMENT REQUEST			M	M	TS 48.008
Cell Identifier (Serving)	ASSIGNMENT COMPLETE HANDOVER REQUEST HANDOVER COMMAND HANDOVER PERFORMED PERFORM LOCATION REQUEST			M	M	TS 48.008
Chosen Channel	ASSIGNMENT COMPLETE HANDOVER REQUEST ACKNOWLEDGE HANDOVER PERFORMED			M	M	TS 48.008
Speech version (chosen)	ASSIGNMENT COMPLETE HANDOVER REQUEST HANDOVER REQUIRED HANDOVER REQUEST ACKNOWLEDGE HANDOVER PERFORMED			M	M	TS 48.008
Cause	ASSIGNMENT FAILURE HANDOVER REQUEST HANDOVER REQUIRED HANDOVER FAILURE CLEAR REQUEST CLEAR COMMAND HANDOVER PERFORMED HANDOVER REQUIRED REJECT			M	M	TS 48.008
RR Cause	ASSIGNMENT FAILURE HANDOVER COMPLETE HANDOVER FAILURE			M	M	TS 48.008
Cell Identifier (target)	HANDOVER REQUEST			M	M	TS 48.008
Current Channel type 1	HANDOVER REQUEST HANDOVER REQUIRED			M	M	TS 48.008
Cell Identifier List (Preferred)	HANDOVER REQUIRED PAGING			M	M	TS 48.008
IMSI	PAGING COMMON ID			M	M	TS 48.008
Location Type	PERFORM LOCATION REQUEST			M	M	TS 48.008
Location Estimate	PERFORM LOCATION RESPONSE			M	M	TS 48.008
LCS Cause	PERFORM LOCATION RESPONSE PERFORM LOCATION ABORT			M	M	TS 48.008

B	MAP	SS-Code	MAP_REGISTER_SS MAP_ERASE_SS MAP_ACTIVATE_SS MAP_DEACTIVATE_SS MAP_INTERROGATE_SS MAP_REGISTER_PASSWORD MAP_REGISTER_CC_ENTRY MAP_ERASE_CC_ENTRY	M	M	TS 29.002
		Forwarded-to number with subaddress	MAP_REGISTER_SS	M	M	TS 29.002
		Basic service	MAP_REGISTER_SS MAP_ERASE_SS MAP_ACTIVATE_SS MAP_DEACTIVATE_SS MAP_INTERROGATE_SS	M	M	TS 29.002
		SM RP DA	MAP-SEND-INFO-FOR-MT-SMS	M	M	TS 29.002
		Service Centre Address	MAP-SEND-INFO-FOR-MO-SMS	M	M	TS 29.002
		Alert Reason	MAP-READY-FOR-SM	M	M	TS 29.002
		Abort reason	Abort	M	M	TS 29.002 TS 23.018
C	MAP	MSISDN	Complete Call Process Access Request ack Process Call Waiting Send Info For Incoming Call ack MAP-SEND-INFO-FOR-MT-SMS MAP-SEND-INFO-FOR-MO-SMS	M	M	TS 29.002 TS 23.018
		IMEI(SV)	Complete Call Page MS ack Process Access Request Process Access Request ack Provide IMEI ack Search For MS ack	M	M	TS 29.002 TS 23.018
		PLMN bearer capability	Complete Call Process Call Waiting	M	M	TS 29.002 TS 23.018
		ISDN bearer capability	Complete Call Process Call Waiting	M	M	TS 29.002 TS 23.018
		IMSI	Page MS Process Access Request Process Access Request ack Provide IMSI ack Search For MS Send Info For Incoming Call ack MAP-SEND-INFO-FOR-MT-SMS	M	M	TS 29.002 TS 23.018
		Location area ID / Current location area ID	Page MS Page MS ack Process Access Request Search For MS ack	M	M	TS 29.002 TS 23.018
		Page type	Page MS Search For MS	M	M	TS 29.002 TS 23.018
		Serving cell ID	Page MS ack Process Access Request Search For MS ack	M	M	TS 29.002 TS 23.018

		Service area ID	Page MS ack Process Access Request Search For MS ack	M	M	TS 29.002 TS 23.018
		CM service type	Process Access Request	M	M	TS 29.002 TS 23.018
		MSRN	Send Info For Incoming Call	M	M	TS 29.002 TS 23.018
		Bearer service	Send Info For Incoming Call Send Info For Outgoing Call	M	M	TS 29.002 TS 23.018
		Teleservice	Send Info For Incoming Call Send Info For Outgoing Call	M	M	TS 29.002 TS 23.018
		Dialled number	Send Info For Incoming Call	M	M	TS 29.002 TS 23.018
		Number of forwarding	Send Info For Incoming Call	M	M	TS 29.002 TS 23.018
		Forwarded-to number	Send Info For Incoming Call ack	M	M	TS 29.002 TS 23.018
		Forwarding reason	Send Info For Incoming Call ack	M	M	TS 29.002 TS 23.018
		Called number	Send Info For Outgoing Call	M	M	TS 29.002 TS 23.018
		MSISDN	Send Routeing Info	M	M	TS 29.002 TS 23.018
		User error	Every message where it appears	M	M	TS 29.002
		Provider error	Every message where it appears	M	M	TS 29.002
		Service Centre Address	MAP-SEND-ROUTING-INFO-FOR-SM MAP-REPORT-SM-DELIVERY-STATUS MAP-ALERT-SERVICE-CENTRE	M	M	TS 29.002
		SM Delivery Outcome	MAP-REPORT-SM-DELIVERY-STATUS	M	M	TS 29.002
		MSISdn-Alert	MAP-ALERT-SERVICE-CENTRE MAP-INFORM-SERVICE-CEN	M	M	TS 29.002
		Number of forwarding	Send Routeing Info	M	M	TS 29.002 TS 23.018
		ISDN BC	Send Routeing Info	M	M	TS 29.002 TS 23.018
		IMSI	Send Routeing Info ack	M	M	TS 29.002 TS 23.018
		Roaming number	Send Routeing Info ack	M	M	TS 29.002 TS 23.018
		Forwarded-to number	Send Routeing Info ack	M	M	TS 29.002 TS 23.018
		Forwarding reason	Send Routeing Info ack	M	M	TS 29.002 TS 23.018
		MSISDN	Send Routeing Info ack MAP_SEND_ROUTING_INFO_FOR_SM	M	M	TS 29.002 TS 23.018
		User error	Every message where it appears	M	M	TS 29.002
		Provider error	Every message where it appears	M	M	TS 29.002
D	MAP	HLR number	MAP_RESTORE_DATA	M	M	TS 29.002
		MS Not Reachable Flag	MAP_RESTORE_DATA	M	M	TS 29.002

		SS-Code	MAP_REGISTER_SS MAP_ERASE_SS MAP_ACTIVATE_SS MAP_DEACTIVATE_SS MAP_INTERROGATE_SS MAP_REGISTER_PASSWORD MAP_REGISTER_CC_ENTRY MAP_ERASE_CC_ENTRY	M	M	TS 29.002
		Forwarded-to number with subaddress	MAP_REGISTER_SS	M	M	TS 29.002
		Basic service	MAP_REGISTER_SS MAP_ERASE_SS MAP_ACTIVATE_SS MAP_DEACTIVATE_SS MAP_INTERROGATE_SS	M	M	TS 29.002
		Alert Reason	MAP-READY-FOR-SM	M	M	TS 29.002
		MSC Address	MAP_UPDATE_LOCATION	M	M	TS 29.002
		IMSI	Provide Roaming Number Provide Subscriber Info MAP_UPDATE_LOCATION MAP_CANCEL_LOCATION MAP_PURGE_MS MAP-INSERT-SUBSCRIBER-DATA MAP-DELETE-SUBSCRIBER-DATA MAP_RESTORE_DATA	M	M	TS 29.002 TS 23.018
		MSISDN	Provide Roaming Number MAP-INSERT-SUBSCRIBER-DATA	M	M	TS 29.002 TS 23.018
		PLMN bearer capability	Provide Roaming Number	M	M	TS 29.002 TS 23.018
		ISDN BC	Provide Roaming Number	M	M	TS 29.002 TS 23.018
		Roaming number	Provide Roaming Number ack	M	M	TS 29.002 TS 23.018
		Service area ID	Provide Subscriber Info ack	M	M	TS 29.002 TS 23.018
		Cell ID	Provide Subscriber Info ack	M	M	TS 29.002 TS 23.018
		IMEI(SV)	Provide Subscriber Info ack	M	M	TS 29.002 TS 23.018
		User error	Every message where it appears	M	M	TS 29.002
		Provider error	Every message where it appears	M	M	TS 29.002
F	MAP	IMEI(SV)	MAP_CHECK_IMEI	M	M	TS 29.002 TS 23.018
		Equipment status	MAP_CHECK_IMEI	M	M	TS 29.002 TS 23.018
		User error	Every message where it appears	M	M	TS 29.002
		Provider error	Every message where it appears	M	M	TS 29.002
E	MAP	Target Cell Id	MAP_PREPARE_HANDOVER MAP_PREPARE_SUBSEQUENT_HANDOVER	M	M	TS 29.002
		Target RNC Id	MAP_PREPARE_HANDOVER MAP_PREPARE_SUBSEQUENT_HANDOVER	M	M	TS 29.002
		IMSI	MAP_PREPARE_HANDOVER	M	M	TS 29.002

		RAB ID/ Selected RAB id	MAP_PREPARE_HANOVER MAP_PROCESS_ACCESS_SIGNALLING MAP_PREPARE_SUBSEQUENT_HANOVER	M	M	TS 29.002
		Handover Number	MAP_PREPARE_HANOVER MAP_SEND_HANOVER_REPORT	M	M	TS 29.002
		User error	Every message where it appears	M	M	TS 29.002
		Provider error	Every message where it appears	M	M	TS 29.002
		Iu-Selected Codec	MAP_PREPARE_HANOVER MAP_PROCESS_ACCESS_SIGNALLING MAP_FORWARD_ACCESS_SIGNALLING	M	M	TS 29.002
		Iu-Currently Used Codec	MAP_PREPARE_HANOVER MAP_FORWARD_ACCESS_SIGNALLING	M	M	TS 29.002
		Iu-Supported Codecs List	MAP_PREPARE_HANOVER MAP_FORWARD_ACCESS_SIGNALLING	M	M	TS 29.002
		Iu-Available Codecs List	MAP_PREPARE_HANOVER MAP_PROCESS_ACCESS_SIGNALLING	M	M	TS 29.002
		Target MSC Number	MAP_PREPARE_SUBSEQUENT_HANOVER	M	M	TS 29.002
G	MAP	IMSI	MAP_SEND_IDENTIFICATION	M	M	TS 29.002
		MSC Number	MAP_SEND_IDENTIFICATION	M	M	TS 29.002
		User error	Every message where it appears	M	M	TS 29.002
		Provider error	Every message where it appears	M	M	TS 29.002
Mc	Megaco	Context	Every procedure where it appears	M	M	TS 23.205
		Bearer Termination 1	Every procedure where it appears	M	M	TS 23.205
		Bearer Termination 2	Every procedure where it appears	M	M	TS 23.205
		Bearer Characteristics	Establish Bearer	M	M	TS 23.205
		Destination Binding Reference	Establish Bearer	M	M	TS 23.205
		Sender Binding Reference	Prepare Bearer	M	M	TS 23.205
		Codec	Prepare Bearer Modify Bearer Characteristics	M	M	TS 23.205
		Release Cause	Release Bearer Bearer Released	M	M	TS 23.205
Iu	RANAP	RAB ID	RAB ASSIGNMENT REQUEST RAB ASSIGNMENT RESPONSE RAB RELEASE REQUEST IU RELEASE COMPLETE RELOCATION REQUEST RELOCATION REQUEST ACKNOWLEDGE RELOCATION COMMAND	M	M	TS 25.413
		Cause	RAB ASSIGNMENT REQUEST RAB ASSIGNMENT RESPONSE RAB RELEASE REQUEST IU RELEASE REQUEST IU RELEASE COMMAND RELOCATION REQUIRED RELOCATION REQUEST RELOCATION REQUEST ACKNOWLEDGE RELOCATION PREPARATION FAILURE RELOCATION FAILURE RELOCATION CANCEL SECURITY MODE REJECT LOCATION REPORT ERROR INDICATION	M	M	TS 25.413

	Source ID	RELOCATION REQUIRED	M	M	TS 25.413
	Target ID	RELOCATION REQUIRED	M	M	TS 25.413
	Paging Cause	PAGING	M	M	TS 25.413
	Permanent NAS UE Identity	COMMON ID PAGING RELOCATION REQUEST	M	M	TS 25.413
	Area Identity	LOCATION REPORT	M	M	TS 25.413
	Last Known Service Area	LOCATION REPORT	M	M	TS 25.413
	LAI	INITIAL UE MESSAGE DIRECT TRANSFER	M	M	TS 25.413
	SAI	INITIAL UE MESSAGE DIRECT TRANSFER	M	M	TS 25.413
	Global RNC-ID	ERROR INDICATION	M	M	TS 25.413

4.3 MGW Trace Record Content

The following table describes the trace record content for minimum and medium trace depth for Megaco protocol in the Media GateWay (MGW).

Interface name	Prot. name	IE name	Procedure name(s)	Trace depth		Notes
				Min	Med	
Mc	Megaco	Context	Every procedure where it appears	M	M	TS 23.205
		Bearer Termination 1	Every procedure where it appears	M	M	TS 23.205
		Bearer Termination 2	Every procedure where it appears	M	M	TS 23.205
		Bearer Characteristics	Establish Bearer	M	M	TS 23.205
		Destination Binding Reference	Establish Bearer	M	M	TS 23.205
		Destination Bearer Address	Establish Bearer	M	M	TS 23.205
		Sender Binding Reference	Prepare Bearer	M	M	TS 23.205
		Sender Bearer Address	Prepare Bearer	M	M	TS 23.205
		Codec	Prepare Bearer Modify Bearer Characteristics	M	M	TS 23.205
	Release Cause	Release Bearer Bearer Released	M	M	TS 23.205	
Iu-UP, Nb-UP		Error Cause value	Every NACK message	M	M	TS 25.415
Iu-UP, Nb-UP		RFCI indicators	Rate control procedure	M	M	TS 25.415
Iu-UP, Nb-UP		Local_Channel_Type	TFO_TRANS	M	M	TS 28.062
Iu-UP, Nb-UP		Indication whether <ENQUIRY> character is received by the CTM receiver	CTM availability negotiation	M	M	TS 26.226

4.4 SGSN Trace Record Content

The following table shows the trace record content for SGSN.

The trace record is the same for management based activation and for signalling based activation.

For SGSN, the Minimum level of detail shall be supported.

Interface name	Prot. name	IE name	Message name(s)	Trace depth		Notes
				Min	Med	
lu	SM	Requested QoS/Requested new QoS	ACTIVATE PDP CONTEXT REQUEST ACTIVATE SECONDARY PDP CONTEXT REQUEST MODIFY PDP CONTEXT REQUEST	M	M	TS 24.008
		Requested PDP address	ACTIVATE PDP CONTEXT REQUEST	M	M	TS 24.008
		Access point name	ACTIVATE PDP CONTEXT REQUEST REQUEST PDP CONTEXT ACTIVATION	M	M	TS 24.008 TS 23.003
		Negotiated QoS/New QoS	ACTIVATE PDP CONTEXT ACCEPT ACTIVATE SECONDARY PDP CONTEXT ACCEPT MODIFY PDP CONTEXT REQUEST MODIFY PDP CONTEXT ACCEPT	M	M	TS 24.008
		PDP Address	ACTIVATE PDP CONTEXT ACCEPT MODIFY PDP CONTEXT REQUEST	M	M	TS 24.008
		SM cause	ACTIVATE PDP CONTEXT REJECT ACTIVATE SECONDARY PDP CONTEXT REJECT REQUEST PDP CONTEXT ACTIVATION REJECT MODIFY PDP CONTEXT REJECT DEACTIVATE PDP CONTEXT REQUEST SM STATUS	M	M	TS 24.008
		Offered PDP address	REQUEST PDP CONTEXT ACTIVATION	M	M	TS 24.008
lu	MM	MS network capability	ATTACH REQUEST ROUTING AREA UPDATE REQUEST	M	M	TS 24.008
		Attach type	ATTACH REQUEST	M	M	TS 24.008
		IMSI	ATTACH REQUEST	M	M	TS 24.008
		MS Radio Access capability	ATTACH REQUEST ROUTING AREA UPDATE REQUEST	M	M	TS 24.008
		Attach result	ATTACH ACCEPT	M	M	TS 24.008
		Routing area identification	ATTACH ACCEPT ROUTING AREA UPDATE REQUEST ROUTING AREA UPDATE ACCEPT	M	M	TS 24.008
		GMM cause	ATTACH ACCEPT ATTACH REJECT DETACH REQUEST AUTHENTICATION AND CIPHERING FAILURE ROUTING AREA UPDATE ACCEPT ROUTING AREA UPDATE REJECT GMM STATUS	M	M	TS 24.008
		Detach type	DETACH REQUEST	M	M	TS 24.008
		Mobile identity	AUTHENTICATION AND CIPHERING RESPONSE IDENTITY RESPONSE ROUTING AREA UPDATE ACCEPT	M	M	TS 24.008
		Update type	ROUTING AREA UPDATE REQUEST	M	M	TS 24.008
Update result	ROUTING AREA UPDATE ACCEPT	M	M	TS 24.008		
lu	SMS	TP-Originating-Address	SMS-DELIVER	M	M	TS 23.040
		TP-Service-Centre-Time-Stamp	SMS-DELIVER SMS-SUBMIT-REPORT SMS-STATUS-REPORT	M	M	TS 23.040
		TP-Failure-Cause	SMS-DELIVER-REPORT SMS-SUBMIT-REPORT	M	M	TS 23.040
		TP-Destination-Address	SMS-SUBMIT SMS-COMMAND	M	M	TS 23.040

		TP-Recipient-Address	SMS-STATUS-REPORT	M	M	TS 23.040
Gn	GTP	IMSI	CREATE PDP CONTEXT REQUEST UPDATE PDP CONTEXT REQUEST PDU NOTIFICATION REQUEST IDENTIFICATION RESPONSE SGSN CONTEXT REQUEST FORWARD RELOCATION REQUEST RELOCATION CANCEL REQUEST MBMS NOTIFICATION REQUEST CREATE MBMS CONTEXT REQUEST UPDATE MBMS CONTEXT REQUEST DELETE MBMS CONTEXT REQUEST	M	M	TS 29.060
		RAI	CREATE PDP CONTEXT REQUEST UPDATE PDP CONTEXT REQUEST IDENTIFICATION REQUEST SGSN CONTEXT REQUEST CREATE MBMS CONTEXT REQUEST UPDATE MBMS CONTEXT REQUEST	M	M	TS 29.060
		End User Address	CREATE PDP CONTEXT REQUEST CREATE PDP CONTEXT RESPONSE UPDATE PDP CONTEXT REQUEST PDU NOTIFICATION REQUEST PDU NOTIFICATION REJECT REQUEST MBMS NOTIFICATION REQUEST MBMS NOTIFICATION REJECT REQUEST CREATE MBMS CONTEXT REQUEST DELETE MBMS CONTEXT REQUEST MBMS REGISTRATION REQUEST MBMS DE-REGISTRATION REQUEST MBMS SESSION START REQUEST MBMS SESSION STOP REQUEST	M	M	TS 29.060
		Access Point Name	CREATE PDP CONTEXT REQUEST PDU NOTIFICATION REQUEST PDU NOTIFICATION REJECT REQUEST MBMS NOTIFICATION REQUEST MBMS NOTIFICATION REJECT REQUEST CREATE MBMS CONTEXT REQUEST DELETE MBMS CONTEXT REQUEST MBMS REGISTRATION REQUEST MBMS DE-REGISTRATION REQUEST MBMS SESSION START REQUEST MBMS SESSION STOP REQUEST	M	M	TS 29.060
		SGSN Address for signalling	CREATE PDP CONTEXT REQUEST UPDATE PDP CONTEXT REQUEST IDENTIFICATION REQUEST SGSN CONTEXT REQUEST SGSN CONTEXT RESPONSE FORWARD RELOCATION REQUEST FORWARD RELOCATION RESPONSE CREATE MBMS CONTEXT REQUEST UPDATE MBMS CONTEXT REQUEST	M	M	TS 29.060

	SGSN Address for user traffic	CREATE PDP CONTEXT REQUEST UPDATE PDP CONTEXT REQUEST SGSN CONTEXT ACKNOWLEDGE MBMS SESSION START RESPONSE	M	M	TS 29.060
	MSISDN	CREATE PDP CONTEXT REQUEST CREATE MBMS CONTEXT REQUEST	M	M	TS 29.060
	Quality of Service Profile	CREATE PDP CONTEXT REQUEST CREATE PDP CONTEXT RESPONSE UPDATE PDP CONTEXT REQUEST UPDATE PDP CONTEXT RESPONSE MBMS SESSION START REQUEST	M	M	TS 29.060
	RAT Type	CREATE PDP CONTEXT REQUEST UPDATE PDP CONTEXT REQUEST	M	M	TS 29.060
	IMEI(SV)	CREATE PDP CONTEXT REQUEST	M	M	TS 29.060
	User Location Information	CREATE PDP CONTEXT REQUEST UPDATE PDP CONTEXT REQUEST	M	M	TS 29.060
	Cause	CREATE PDP CONTEXT RESPONSE UPDATE PDP CONTEXT RESPONSE DELETE PDP CONTEXT RESPONSE PDU NOTIFICATION RESPONSE PDU NOTIFICATION REJECT REQUEST PDU NOTIFICATION REJECT RESPONSE IDENTIFICATION RESPONSE SGSN CONTEXT RESPONSE SGSN CONTEXT ACKNOWLEDGE FORWARD RELOCATION RESPONSE RELOCATION CANCEL RESPONSE FORWARD RELOCATION COMPLETE ACKNOWLEDGE FORWARD SRNS CONTEXT ACKNOWLEDGE MBMS NOTIFICATION RESPONSE MBMS NOTIFICATION REJECT REQUEST MBMS NOTIFICATION REJECT RESPONSE CREATE MBMS CONTEXT RESPONSE UPDATE MBMS CONTEXT RESPONSE DELETE MBMS CONTEXT RESPONSE MBMS REGISTRATION RESPONSE MBMS DE-REGISTRATION RESPONSE MBMS SESSION START RESPONSE MBMS SESSION STOP RESPONSE	M	M	TS 29.060
	GGSN Address for Control Plane	CREATE PDP CONTEXT RESPONSE UPDATE PDP CONTEXT RESPONSE PDU NOTIFICATION REQUEST MBMS NOTIFICATION REQUEST CREATE MBMS CONTEXT RESPONSE UPDATE MBMS CONTEXT RESPONSE	M	M	TS 29.060
	GGSN Address for user traffic	CREATE PDP CONTEXT RESPONSE UPDATE PDP CONTEXT RESPONSE	M	M	TS 29.060
	GSN Address	ERROR INDICATION	M	M	TS 29.060
	SGSN Number	SGSN CONTEXT REQUEST FORWARD RELOCATION RESPONSE	M	M	TS 29.060
	MBMS UE Context	SGSN CONTEXT RESPONSE FORWARD RELOCATION REQUEST	M	M	TS 29.060

Gs	BSSAP+	RANAP Cause	FORWARD RELOCATION REQUEST FORWARD RELOCATION RESPONSE	M	M	TS 29.060
		Target Identification	FORWARD RELOCATION REQUEST	M	M	TS 29.060
		IMSI	BSSAP+-ALERT-ACK BSSAP+-ALERT-REJECT BSSAP+-ALERT-REQUEST BSSAP+-DOWNLINK-TUNNEL-REQUEST BSSAP+-GPRS-DETACH-ACK BSSAP+-GPRS-DETACH-INDICATION BSSAP+-IMSI-DETACH-ACK BSSAP+-IMSI-DETACH-INDICATION BSSAP+-LOCATION-UPDATE-ACCEPT BSSAP+-LOCATION-UPDATE-REJECT BSSAP+-LOCATION-UPDATE-REQUEST BSSAP+-MOBILE-STATUS BSSAP+-MS-ACTIVITY-INDICATION BSSAP+-MS-UNREACHABLE BSSAP+-PAGING-REJECT BSSAP+-PAGING-REQUEST BSSAP+-TMSI-REALLOCATION-COMPLETE BSSAP+-UPLINK-TUNNEL-REQUEST	M	M	TS 29.018
		Gs Cause	BSSAP+-ALERT-REJECT BSSAP+-MOBILE-STATUS BSSAP+-MS-UNREACHABLE BSSAP+-PAGING-REJECT	M	M	TS 29.018
		VLR number	BSSAP+-DOWNLINK-TUNNEL-REQUEST BSSAP+-PAGING-REQUEST BSSAP+-RESET-ACK BSSAP+-RESET-INDICATION	M	M	TS 29.018
		SGSN number	BSSAP+-GPRS-DETACH-INDICATION BSSAP+-IMSI-DETACH-INDICATION BSSAP+-LOCATION-UPDATE-REQUEST BSSAP+-RESET-ACK BSSAP+-RESET-INDICATION BSSAP+-UPLINK-TUNNEL-REQUEST	M	M	TS 29.018
		IMSI detach from GPRS service type	BSSAP+-GPRS-DETACH-INDICATION	M	M	TS 29.018
		Cell global identity/ New CGI	BSSAP+-GPRS-DETACH-INDICATION BSSAP+-IMSI-DETACH-INDICATION BSSAP+-LOCATION-UPDATE-REQUEST BSSAP+-MS-ACTIVITY-INDICATION BSSAP+-TMSI-REALLOCATION-COMPLETE	M	M	TS 29.018
		Service area identification /New SAI	BSSAP+-GPRS-DETACH-INDICATION BSSAP+-IMSI-DETACH-INDICATION BSSAP+-LOCATION-UPDATE-REQUEST BSSAP+-MS-ACTIVITY-INDICATION BSSAP+-TMSI-REALLOCATION-COMPLETE	M	M	TS 29.018
		Detach type	BSSAP+-IMSI-DETACH-INDICATION	M	M	TS 29.018
		Reject cause	BSSAP+-LOCATION-UPDATE-REJECT	M	M	TS 29.018
		Update type	BSSAP+-LOCATION-UPDATE-REQUEST	M	M	TS 29.018
		LAI/Old LAI	BSSAP+-LOCATION-UPDATE-ACCEPT BSSAP+-LOCATION-UPDATE-REQUEST BSSAP+-PAGING-REQUEST	M	M	TS 29.018
IMEISV	BSSAP+-LOCATION-UPDATE-REQUEST	M	M	TS 29.018		

		Erroneous message	BSSAP+-MOBILE-STATUS	M	M	TS 29.018
Gr	MAP	IMSI	MAP_CANCEL_LOCATION MAP_PURGE_MS MAP_UPDATE_GPRS_LOCATION MAP_NOTE_MM_EVENT MAP-INSERT-SUBSCRIBER-DATA MAP-DELETE-SUBSCRIBER-DATA MAP-READY-FOR-SM	M	M	TS 29.002
		Cancellation Type	MAP_CANCEL_LOCATION	M	M	TS 29.002
		User error	Every message where it appears	M	M	TS 29.002
		Provider error	Every message where it appears	M	M	TS 29.002
		Location Information for GPRS	MAP_NOTE_MM_EVENT	M	M	TS 29.002
		MSISDN	MAP-INSERT-SUBSCRIBER-DATA	M	M	TS 29.002
		Alert Reason	MAP-READY-FOR-SM	M	M	TS 29.002
Gd	MAP	SM RP OA	MAP-MO-FORWARD-SHORT-MESSAGE MAP-MT-FORWARD-SHORT-MESSAGE	M	M	TS 29.002
		SM RP DA	MAP-MO-FORWARD-SHORT-MESSAGE MAP-MT-FORWARD-SHORT-MESSAGE	M	M	TS 29.002
		IMSI	MAP-MO-FORWARD-SHORT-MESSAGE	M	M	TS 29.002
		More Messages To Send	MAP-MT-FORWARD-SHORT-MESSAGE	M	M	TS 29.002
Gf	MAP	IMEI(SV)	MAP_CHECK_IMEI	M	M	TS 29.002
		Equipment status	MAP_CHECK_IMEI	M	M	TS 29.002
		User error	Every message where it appears	M	M	TS 29.002
		Provider error	Every message where it appears	M	M	TS 29.002
Iu	RANAP	RAB ID	RAB ASSIGNMENT REQUEST RAB ASSIGNMENT RESPONSE RAB RELEASE REQUEST IU RELEASE COMPLETE RELOCATION REQUEST RELOCATION REQUEST ACKNOWLEDGE RELOCATION COMMAND	M	M	TS 25.413
		Cause	RAB ASSIGNMENT REQUEST RAB ASSIGNMENT RESPONSE RAB RELEASE REQUEST IU RELEASE REQUEST IU RELEASE COMMAND RELOCATION REQUIRED RELOCATION REQUEST RELOCATION REQUEST ACKNOWLEDGE RELOCATION PREPARATION FAILURE RELOCATION FAILURE RELOCATION CANCEL SECURITY MODE REJECT LOCATION REPORT ERROR INDICATION	M	M	TS 25.413
		Source ID	RELOCATION REQUIRED	M	M	TS 25.413
		Target ID	RELOCATION REQUIRED	M	M	TS 25.413
		Paging Cause	PAGING	M	M	TS 25.413
		Permanent NAS UE Identity	COMMON ID PAGING RELOCATION REQUEST	M	M	TS 25.413
		Area Identity	LOCATION REPORT	M	M	TS 25.413

		Last Known Service Area	LOCATION REPORT	M	M	TS 25.413
		RAC	INITIAL UE MESSAGE DIRECT TRANSFER	M	M	TS 25.413
		SAI	INITIAL UE MESSAGE DIRECT TRANSFER	M	M	TS 25.413
		Global RNC-ID	ERROR INDICATION	M	M	TS 25.413
S3	GTPv2C	IMSI	DETACH NOTIFICATION CS PAGING INDICATON RELOCATION CANCEL Request IDENTIFICATION RESPONSE CONTEXT RESPONSE CONTEXT REQUEST FORWARD RELOCATION REQUEST	M	M	TS 29.274
		TMSI	CS PAGING INDICATON	M	M	TS 29.274
		GUTI	CONTEXT REQUEST IDENTIFICATION Request	M	M	TS 29.274
		RAI	IDENTIFICATION Request CONTEXT REQUEST	M	M	TS 29.274
		P-TMSI	IDENTIFICATION Request CONTEXT REQUEST	M	M	TS 29.274
		Indication	FORWARD RELOCATION COMPLETE NOTIFICATION FORWARD RELOCATION REQUEST	M	M	TS 29.274
		BSSGP Cause	FORWARD RELOCATION RESPONSE FORWARD RELOCATION REQUEST	M	M	TS 29.274
		RANAP Cause	FORWARD RELOCATION RESPONSE FORWARD RELOCATION REQUEST	M	M	TS 29.274
		eNodeB Cause	FORWARD RELOCATION RESPONSE	M	M	TS 29.274
		RAT Type	CONTEXT REQUEST	M	M	TS 29.274
		Target Identification	FORWARD RELOCATION REQUEST	M	M	TS 29.274
		Cause	RELOCATION CANCEL RESPONSE FORWARD SRNS CONTEXT ACKNOWLEDGE IDENTIFICATION RESPONSE CONTEXT ACKNOWLEDGE CONTEXT RESPONSE FORWARD RELOCATION COMPLETE ACKNOWLEDGE FORWARD RELOCATION RESPONSE DETACH NOTIFICATION DETACH aCKNOWLEDGE	M	M	TS 29.274
		RAN Cause	FORWARD RELOCATION REQUES	M	M	TS 29.274
		Selected PLMN ID	FORWARD RELOCATION REQUEST	M	M	TS 29.274
S4	GTPV2C	Traffic Aggregate Description (TAD)	Bearer Resource Command	M	M	TS 25.413
		Linked Bearer Identity (LBI)	Bearer Resource Command Create Bearer Request Delete Bearer Response	M	M	TS 25.413
		Linked EPS Bearer ID	Bearer Resource Failure Indication Delete Session Request Delete Bearer Request	M	M	TS 25.413

		Cause	Bearer Resource Failure Indication Create Session Response Create Bearer Response Modify Bearer Response Delete Session Response Delete Bearer Response Downlink Data Notification Acknowledgement Downlink Data Notification Failure Indication Update Bearer Response Create Indirect Data Forwarding Tunnel Response Update Bearer Complete	M	M	TS 25.413
		Bearer Contexts to be modified	Modify Bearer Request	M	M	TS 25.413
		Bearer Contexts to be removed	Modify Bearer Request	M	M	TS 25.413
		IMSI	Create Session Request Update Bearer Request	M	M	TS 25.413
		MSISDN	Create Session Request Modify Bearer Response	M	M	TS 25.413
		Serving Network	Create Session Request	M	M	TS 25.413
		Access Point Name (APN)	Create Session Request	M	M	TS 25.413
		PDN Type	Create Session Request	M	M	TS 25.413
		Bearer Contexts	Create Session Request Create Bearer Request Create Bearer Response Delete Bearer Request Delete Bearer Response Update Bearer Request Update Bearer Response Create Indirect Data Forwarding Tunnel Request Create Indirect Data Forwarding Tunnel Response Update Bearer Complete	M	M	TS 25.413
		RAT Type	Create Session Request Modify Bearer Request	M	M	TS 25.413
		Bearer Contexts created	Create Session Response	M	M	TS 25.413
		Bearer Contexts marked for removal	Create Session Response	M	M	TS 25.413
		Bearer Contexts modified	Modify Bearer Response	M	M	TS 25.413
		Bearer Contexts marked for removal	Modify Bearer Response	M	M	TS 25.413
S6d	Diameter	User Name	NOTIFY REQUEST AUTHENTICATION INFORMATION REQUEST DELETE SUBSCRIBER DATA REQUEST INSERT SUBSCRIBER DATA REQUEST PURGE UE REQUEST CANCEL LOCATION REQUEST UPDATE LOCATION REQUEST	M	M	TS 29.272
		Terminal Information	NOTIFY REQUEST UPDATE LOCATION REQUEST	M	M	TS 29.272
		Result	NOTIFY ANSWER AUTHENTICATION INFORMATION ANSWER DELETE SUBSCRIBER DATA ANSWER INSERT SUBSCRIBER DATA ANSWER PURGE UE ANSWER CANCEL LOCATION ANSWER UPDATE LOCATION ANSWER	M	M	TS 29.272

		RAT Type	UPDATE LOCATION REQUEST	M	M	TS 29.272
		APN	NOTIFY REQUEST	M	M	TS 29.272
		Visited PLMN Id	AUTHENTICATION INFORMATION REQUEST UPDATE LOCATION REQUEST	M	M	TS 29.272
S13'	Diameter	Terminal Information	ME Identity Check Request	M	M	TS 29.272
		Result	ME Identity Check Answer	M	M	TS 29.272

4.5 GGSN Trace Record Content

The following table describes the trace record content for minimum and medium trace depth for GGSN. The record content is same for management based activation and for signalling based activation. For GGSN, the Minimum level of detail shall be supported.

Interface name	Prot. Name	IE name	MESSAGE NAME(S)	Trace depth		Notes
				Min	Med	
Gn	GTP	IMSI	CREATE PDP CONTEXT REQUEST UPDATE PDP CONTEXT REQUEST PDU NOTIFICATION REQUEST SEND ROUTEING INFORMATION FOR GPRS REQUEST SEND ROUTEING INFORMATION FOR GPRS RESPONSE FAILURE REPORT REQUEST NOTE MS PRESENT REQUEST MBMS NOTIFICATION REQUEST CREATE MBMS CONTEXT REQUEST UPDATE MBMS CONTEXT REQUEST DELETE MBMS CONTEXT REQUEST	M	M	TS 29.060
		RAI	CREATE PDP CONTEXT REQUEST UPDATE PDP CONTEXT REQUEST CREATE MBMS CONTEXT REQUEST UPDATE MBMS CONTEXT REQUEST	M	M	TS 29.060
		End User Address	CREATE PDP CONTEXT REQUEST CREATE PDP CONTEXT RESPONSE UPDATE PDP CONTEXT REQUEST PDU NOTIFICATION REQUEST PDU NOTIFICATION REJECT REQUEST MBMS NOTIFICATION REQUEST MBMS NOTIFICATION REJECT REQUEST CREATE MBMS CONTEXT REQUEST DELETE MBMS CONTEXT REQUEST MBMS REGISTRATION REQUEST MBMS DE-REGISTRATION REQUEST MBMS SESSION START REQUEST MBMS SESSION STOP REQUEST	M	M	TS 29.060
		Access Point Name	CREATE PDP CONTEXT REQUEST PDU NOTIFICATION REQUEST PDU NOTIFICATION REJECT REQUEST MBMS NOTIFICATION REQUEST MBMS NOTIFICATION REJECT REQUEST CREATE MBMS CONTEXT REQUEST DELETE MBMS CONTEXT REQUEST MBMS REGISTRATION REQUEST MBMS DE-REGISTRATION REQUEST MBMS SESSION START REQUEST MBMS SESSION STOP REQUEST	M	M	TS 29.060
		SGSN Address for signalling	CREATE PDP CONTEXT REQUEST UPDATE PDP CONTEXT REQUEST CREATE MBMS CONTEXT REQUEST UPDATE MBMS CONTEXT REQUEST	M	M	TS 29.060
		SGSN Address for user traffic	CREATE PDP CONTEXT REQUEST UPDATE PDP CONTEXT REQUEST MBMS SESSION START RESPONSE	M	M	TS 29.060
		MSISDN	CREATE PDP CONTEXT REQUEST CREATE MBMS CONTEXT REQUEST	M	M	TS 29.060

		Quality of Service Profile	CREATE PDP CONTEXT REQUEST CREATE PDP CONTEXT RESPONSE UPDATE PDP CONTEXT REQUEST UPDATE PDP CONTEXT RESPONSE MBMS SESSION START REQUEST	M	M	TS 29.060
		RAT Type	CREATE PDP CONTEXT REQUEST UPDATE PDP CONTEXT REQUEST	M	M	TS 29.060
		IMEI(SV)	CREATE PDP CONTEXT REQUEST	M	M	TS 29.060
		User Location Information	CREATE PDP CONTEXT REQUEST UPDATE PDP CONTEXT REQUEST	M	M	TS 29.060
		Cause	CREATE PDP CONTEXT RESPONSE UPDATE PDP CONTEXT RESPONSE DELETE PDP CONTEXT RESPONSE PDU NOTIFICATION RESPONSE PDU NOTIFICATION REJECT REQUEST PDU NOTIFICATION REJECT RESPONSE SEND ROUTEING INFORMATION FOR GPRS RESPONSE FAILURE REPORT RESPONSE NOTE MS GPRS PRESENT RESPONSE MBMS NOTIFICATION RESPONSE MBMS NOTIFICATION REJECT REQUEST MBMS NOTIFICATION REJECT RESPONSE CREATE MBMS CONTEXT RESPONSE UPDATE MBMS CONTEXT RESPONSE DELETE MBMS CONTEXT RESPONSE MBMS REGISTRATION RESPONSE MBMS DE-REGISTRATION RESPONSE MBMS SESSION START RESPONSE MBMS SESSION STOP RESPONSE	M	M	TS 29.060
		GGSN Address for Control Plane	CREATE PDP CONTEXT RESPONSE UPDATE PDP CONTEXT RESPONSE PDU NOTIFICATION REQUEST MBMS NOTIFICATION REQUEST CREATE MBMS CONTEXT RESPONSE UPDATE MBMS CONTEXT RESPONSE	M	M	TS 29.060
		GGSN Address for user traffic	CREATE PDP CONTEXT RESPONSE UPDATE PDP CONTEXT RESPONSE	M	M	TS 29.060
		MAP Cause	SEND ROUTEING INFORMATION FOR GPRS RESPONSE FAILURE REPORT RESPONSE	M	M	TS 29.060
		GSN Address	SEND ROUTEING INFORMATION FOR GPRS RESPONSE NOTE MS PRESENT REQUEST	M	M	TS 29.060
Gmb	Diameter Gmb	IMSI	MBMS AUTHORIZATION REQUEST (AAR) MBMS AUTHORIZATION RESPONSE (AAA)	M	M	TS 29.061
		RAI	MBMS AUTHORIZATION REQUEST (AAR)	M	M	TS 29.061
		Access Point Name	MBMS AUTHORIZATION REQUEST (AAR)	M	M	TS 29.061
		MSISDN	MBMS AUTHORIZATION REQUEST (AAR)	M	M	TS 29.061
		IMEI(SV)	MBMS AUTHORIZATION REQUEST (AAR)	M	M	TS 29.061
		IP Multicast Address	MBMS AUTHORIZATION REQUEST (AAR)	M	M	TS 29.061
		TMGI	MBMS AUTHORIZATION RESPONSE (AAA)	M	M	TS 29.061

	Result-Code	MBMS AUTHORIZATION RESPONSE (AAA) MBMS USER DEACTIVATION RESPONSE (STA) MBMS SESSION START-STOP INDICATION RESPONSE (RAA) MBMS SERVICE TERMINATION ANSWER (ASR)	M	M	TS 29.061
	Experimental-Result	MBMS AUTHORIZATION RESPONSE (AAA) MBMS SESSION START-STOP INDICATION RESPONSE (RAA)	M	M	TS 29.061
	Error-Reporting-Host	MBMS AUTHORIZATION RESPONSE (AAA) MBMS USER DEACTIVATION RESPONSE (STA) MBMS SESSION START-STOP INDICATION RESPONSE (RAA) MBMS SERVICE TERMINATION ANSWER (ASR)	M	M	TS 29.061

4.6 UTRAN Trace Record Content

For RNC, the Maximum level of detail shall be supported.

Table 4.6.1 : UTRAN Trace Record Content

Interface (specific messages)	Format	Level of details			Description
		Min	Med	Max	
RRC (without rrc dedicated measurements)	Decoded	M	M	O	Message name
		O	O	O	Record extensions
		M	M	X	rnclD of traced RNC
		M	M	X	Dedicated IE extracted from RRC messages between the traced RNC and the UE. A subset of IEs as given in the table 4.6.2. is provided.
	ASN.1	X	X	M	Raw Uu Messages: RRC messages between the traced RNC and the UE. The encoded content of the message is provided
Iub (without nbap dedicated measurements)	Decoded	M	M	O	Message name
		O	O	O	Record extensions
		M	M	X	rnclD of traced RNC cld
		M	M	X	rbld + Dedicated IE extracted from NBAP messages send/received inside traced UEs communication context. A subset of IEs as given in the table 4.6.2.is provided
	ASN.1	X	X	M	Raw Iub Messages: NBAP messages between the traced RNC and the NodeB or cell. The encoded content of the message is provided
Iu	Decoded	M	M	O	Message name
		O	O	O	Record extensions
		M	M	X	rnclD of traced RNC CoreNetworkID CN Domain Indicator
		M	M	X	rabld + Dedicated IE extracted from RANAP messages between the traced RNC and Core Network. A subset of IEs as given in the table 4.6.2. is provided.
	ASN.1	X	X	M	Raw Iu Messages RANAP: messages between the traced RNC and Core Network The encoded content of the message is provided
Iur	Decoded	M	M	O	Message name
		O	O	O	Record extensions
		M	M	X	rnclD of traced RNC rnclD of neighbouring RNC
		M	M	X	rlld + Dedicated IE extracted from RNSAP messages between the traced RNC and the neighbouring RNC. A subset of IEs as given in the table 4.6.2.is provided
	ASN.1	X	X	M	Raw Iur Messages: RNSAP messages between the traced RNC and the neighbouring RNC. The encoded content of the message is provided
nbap (only dedicated measurements)	Decoded	X	M	X	Iub IEs from NBAP measurement reports messages
	ASN.1	X	X	M	NBAP measurement reports messages
rrc (only dedicated measurements)	Decoded	X	M	X	Uu IEs from RRC measurement reports messages
	ASN.1	X	X	M	RRC measurement reports messages

Definitions:

- rncID of traced RNC: The id of the RNC traced, e.g. the RNC which handles the connection of the traced MS, during the Trace Recording Session.
- rncID of neighbouring RNC: The ids of all Neighbouring RNC involved in the Iur procedures during the Trace Recording Session.
- cId: RNSAP messages
The cIds of all cells involved in the Iub and Iur procedures during the Trace Recording Session. The cId is provided with each NBAP and
for which the cId is relevant.
- rabId: Specific recorded IE that contains the RAB identifier.
- rliId: Specific recorded IE that contains the Radio Link identifier
- rbiId: Specific recorded IE that contains the Radio Bearer identifier
- Message name: Name of the protocol message
- Record extensions: A set of manufacturer specific extensions to the record
- Decoded: Some IEs shall be decoded (cf. detailed list in table 4.6.2. depending on trace depth)
- ASN.1: Messages in encoded format

Table 4.6.2 : trace record description for minimum and medium trace depth

Interface name	Prot. name	IE name	Message name(s)	Trace depth		Notes
				Min	Med	
Uu	RRC	RAB info type	RADIO BEARER SETUP HO TO UTRAN COMMAND RADIO BEARER RELEASE RADIO BEARER RECONFIGURATION	M	M	TS 25.331
		RB info type	RADIO BEARER RECONFIGURATION RADIO BEARER RELEASE RADIO BEARER SETUP HO TO UTRAN COMMAND	M	M	TS 25.331
		URA identity	RADIO BEARER SETUP RADIO BEARER RELEASE URA UPDATE CONFIRM RADIO BEARER RECONFIGURATION	M	M	TS 25.331
		CN domain	SIGNALLING CONNECTION RELEASE INITIAL DIRECT TRANSFER DL DIRECT TRANSFER UL DIRECT TRANSFER	M	M	TS 25.331
		Logical channel priority	RADIO BEARER SETUP	M	M	TS 25.331
		RRC state indicator	RADIO BEARER SETUP PHYSICAL CHANNEL RECONFIGURATION TRANSPORT CHANNEL RECONFIGURATION RADIO BEARER RECONFIGURATION CELL UPDATE CONFIRM URA UPDATE CONFIRM	M	M	TS 25.331
		Primary CPICH scrambling code of added cell	ACTIVE SET UPDATE	O	O	TS 25.331
		Primary CPICH scrambling code of removed cell	ACTIVE SET UPDATE	O	O	TS 25.331
		Target cell identity	CELL CHANGE ORDER	M	M	TS 25.331
		Cell synchronisation information	RRC/MEASUREMENT REPORT for measurement = intra frequency	X	M	TS 25.331
		Cell parameters Id	RRC/MEASUREMENT REPORT for measurement = intra frequency	O	O	TS 25.331
		Timeslot list	RRC/MEASUREMENT REPORT for measurement = intra frequency	X	O	TS 25.331
		CPICH Ec/No	RRC/MEASUREMENT REPORT for measurement = intra frequency	X	O	TS 25.331
		CPICH RSCP	RRC/MEASUREMENT REPORT for measurement = intra frequency	X	O	TS 25.331
PCCPCH RSCP	RRC/MEASUREMENT REPORT for measurement = intra frequency	X	O	TS 25.331		

	Pathloss	RRC/MEASUREMENT REPORT for measurement = intra frequency	X	M	TS 25.331
	UARFCN uplink (Nu)	RRC/MEASUREMENT REPORT for measurement = inter frequency	X	O	TS 25.331
	UARFCN downlink (Nd)	RRC/MEASUREMENT REPORT for measurement = inter frequency	X	O	TS 25.331
	UARFCN (Nt)	RRC/MEASUREMENT REPORT for measurement = inter frequency	X	O	TS 25.331
	Cell synchronisation information	RRC/MEASUREMENT REPORT for measurement = inter frequency	X	M	TS 25.331
	CPICH Ec/No	RRC/MEASUREMENT REPORT for measurement = inter frequency	X	O	TS 25.331
	CPICH RSCP	RRC/MEASUREMENT REPORT for measurement = inter frequency	X	O	TS 25.331
	PCCPCH RSCP	RRC/MEASUREMENT REPORT for measurement = inter frequency	X	O	TS 25.331
	Pathloss	RRC/MEASUREMENT REPORT for measurement = inter frequency	X	M	TS 25.331
	Cell parameters Id	RRC/MEASUREMENT REPORT for measurement = inter frequency	O	O	TS 25.331
	Timeslot list	RRC/MEASUREMENT REPORT for measurement = inter frequency	X	O	TS 25.331
	BCCH ARFCN	RRC/MEASUREMENT REPORT for measurement = inter RAT	X	M	TS 25.331
	GSM Carrier RSSI	RRC/MEASUREMENT REPORT for measurement = inter RAT	X	M	TS 25.331
	RLC buffer Payload	RRC/MEASUREMENT REPORT for measurement = traffic volume	X	M	TS 25.331
	Average RLC buffer payload	RRC/MEASUREMENT REPORT for measurement = traffic volume	X	M	TS 25.331
	Variance of RLC buffer payload	RRC/MEASUREMENT REPORT for measurement = traffic volume	X	M	TS 25.331

lub	NBAP	RL identity	RADIO LINK SETUP REQUEST RADIO LINK RECONFIGURATION PREPARE RADIO LINK RECONFIGURATION REQUEST RADIO LINK RECONFIGURATION READY RADIO LINK RECONFIGURATION FAILURE RADIO LINK RECONFIGURATION RESPONSE RADIO LINK ADDITION REQUEST RADIO LINK RECONFIGURATION REQUEST RADIO LINK SETUP RESPONSE RADIO LINK SETUP FAILURE RADIO LINK ADDITION RESPONSE RADIO LINK ADDITION FAILURE RADIO LINK DELETION REQUEST	M	M	TS 25.433
		RL info type	RADIO LINK SETUP FAILURE RADIO LINK ADDITION FAILURE RADIO LINK RECONFIGURATION FAILURE	M	M	TS 25.433
		C-ID	RADIO LINK SETUP REQUEST RADIO LINK ADDITION REQUEST	M	M	TS 25.433
		UL Scrambling Code	RADIO LINK SETUP REQUEST RADIO LINK RECONFIGURATION PREPARE	O	O	TS 25.433
		UL Timeslot information	RADIO LINK SETUP REQUEST RADIO LINK RECONFIGURATION PREPARE	O	O	TS 25.433
		UL SIR target	RADIO LINK SETUP REQUEST RADIO LINK RECONFIGURATION PREPARE	M	M	TS 25.433
		Minimum UL channelization length	RADIO LINK SETUP REQUEST RADIO LINK RECONFIGURATION PREPARE	O	O	TS 25.433
		Initial DL transmission Power	RADIO LINK SETUP REQUEST RADIO LINK ADDITION REQUEST	M	M	TS 25.433
		Maximum DL transmission Power	RADIO LINK SETUP REQUEST RADIO LINK RECONFIGURATION PREPARE RADIO LINK ADDITION REQUEST RADIO LINK RECONFIGURATION REQUEST	M	M	TS 25.433
		Minimum DL transmission Power	RADIO LINK SETUP REQUEST RADIO LINK ADDITION REQUEST RADIO LINK RECONFIGURATION PREPARE RADIO LINK RECONFIGURATION REQUEST	M	M	TS 25.433
		DL scrambling code	RADIO LINK SETUP REQUEST RADIO LINK ADDITION REQUEST RADIO LINK RECONFIGURATION PREPARE RADIO LINK RECONFIGURATION REQUEST	O	O	TS 25.433
		DL Code information	RADIO LINK SETUP REQUEST RADIO LINK ADDITION REQUEST RADIO LINK RECONFIGURATION PREPARE RADIO LINK RECONFIGURATION REQUEST	O	O	TS 25.433

		DL Timeslot information	RADIO LINK SETUP REQUEST RADIO LINK RECONFIGURATION PREPARE RADIO LINK RECONFIGURATION REQUEST	O	O	TS25.433
		Puncture limit	RADIO LINK SETUP REQUEST RADIO LINK RECONFIGURATION PREPARE	M	M	TS 25.433
		UL Time Slot ISCP Info	RADIO LINK SETUP RESPONSE RADIO LINK ADDITION RESPONSE	O	O	TS 25.433
		Received total wide band power	RADIO LINK SETUP RESPONSE RADIO LINK SETUP FAILURE RADIO LINK ADDITION RESPONSE RADIO LINK ADDITION FAILURE	O	O	TS 25.433
lu	RANAP	RAB identity	All messages where it is present	M	M	TS 25.413
		RAB info type	RAB ASSIGNMENT REQUEST RELOCATION REQUEST RAB MODIFY REQUEST RAB ASSIGNMENT RESPONSE	M	M	TS 25.413
		RAB parameters	RAB ASSIGNMENT REQUEST RELOCATION REQUEST	M	M	TS 25.413
		Assigned RAB parameters values	RAB ASSIGNMENT RESPONSE	M	M	TS 25.413
		Requested RAB parameters values	RAB MODIFY REQUEST	M	M	TS 25.413
		Source ID	RELOCATION REQUIRED	M	M	TS 25.413
		Target ID	RELOCATION REQUIRED	M	M	TS 25.413
		LAI	DIRECT TRANSFER	M	M	TS 25.413
		RAC	DIRECT TRANSFER	M	M	TS 25.413
SAI	DIRECT TRANSFER	M	M	TS 25.413		
lur	RNSAP	RL id identity	RADIO LINK SETUP REQUEST RADIO LINK RECONFIGURATION PREPARE RADIO LINK RECONFIGURATION REQUEST RADIO LINK RECONFIGURATION READY RADIO LINK RECONFIGURATION FAILURE RADIO LINK RECONFIGURATION RESPONSE RADIO LINK ADDITION REQUEST RADIO LINK RECONFIGURATION REQUEST RADIO LINK SETUP RESPONSE RADIO LINK SETUP FAILURE RADIO LINK ADDITION RESPONSE RADIO LINK ADDITION FAILURE RADIO LINK DELETION REQUEST	M	M	TS 25.423
		C-ID	RADIO LINK SETUP REQUEST RADIO LINK ADDITION REQUEST	M	M	TS 25.423

	RL info type	RADIO LINK SETUP FAILURE RADIO LINK ADDITION FAILURE RADIO LINK SETUP FAILURE RADIO LINK RECONFIGURATION FAILURE	M	M	TS 25.423
	UL Scrambling Code	RADIO LINK SETUP REQUEST RADIO LINK RECONFIGURATION PREPARE	O	O	TS 25.423
	UL Timeslot information	RADIO LINK SETUP REQUEST RADIO LINK RECONFIGURATION PREPARE	O	O	TS25.423
	UL SIR target	RADIO LINK SETUP REQUEST RADIO LINK RECONFIGURATION PREPARE	M	M	TS 25.423
	Minimum UL channelization length	RADIO LINK SETUP REQUEST RADIO LINK RECONFIGURATION PREPARE	O	O	TS 25.423
	Initial DL transmission Power	RADIO LINK SETUP REQUEST RADIO LINK ADDITION REQUEST	M	M	TS 25.423
	Maximum DL transmission Power	RADIO LINK SETUP REQUEST RADIO LINK RECONFIGURATION PREPARE RADIO LINK ADDITION REQUEST RADIO LINK RECONFIGURATION REQUEST	M	M	TS 25.423
	Minimum DL transmission Power	RADIO LINK SETUP REQUEST RADIO LINK ADDITION REQUEST RADIO LINK RECONFIGURATION PREPARE RADIO LINK RECONFIGURATION REQUEST	M	M	TS 25.423
	DL scrambling code	RADIO LINK SETUP REQUEST RADIO LINK ADDITION REQUEST RADIO LINK RECONFIGURATION PREPARE RADIO LINK RECONFIGURATION REQUEST	O	O	TS 25.423
	DL channelization code	RADIO LINK SETUP REQUEST RADIO LINK ADDITION REQUEST RADIO LINK RECONFIGURATION PREPARE RADIO LINK RECONFIGURATION REQUEST	O	O	TS 25.423
	DL Timeslot information	RADIO LINK SETUP REQUEST RADIO LINK RECONFIGURATION PREPARE RADIO LINK RECONFIGURATION REQUEST	O	O	TS 25.423
	Puncture limit	RADIO LINK SETUP REQUEST RADIO LINK RECONFIGURATION PREPARE	M	M	TS 25.423
	UL Time Slot ISCP Info	RADIO LINK SETUP RESPONSE RADIO LINK ADDITION RESPONSE	O	O	TS 25.423
	Received total wide band power	RADIO LINK SETUP RESPONSE RADIO LINK SETUP FAILURE RADIO LINK ADDITION RESPONSE RADIO LINK ADDITION FAILURE	O	O	TS 25.423

Constraints:

The following optional IE names shall be supported for corresponding modes as described below:

For FDD mode:

- Primary CPICH scrambling code of added cell
- Primary CPICH scrambling code of removed cell
- CPICH Ec/No
- CPICH RSCP
- UL Scrambling Code
- Minimum UL channelization length
- UARFCN downlink (Nd)
- UARFCN uplink (Nu)
- DL Scrambling Code
- DL Code information
- DL channelization code
- Received total wide band power

For TDD mode :

- PCCPCH RSCP
- Cell parameters Id
- UARFCN (Nt)
- Timeslot list
- UL Timeslot information
- DL Timeslot information
- UL Time Slot ISCP Info

4.7 Void

4.8 Void

4.9 HSS Trace Record Content

The following table contains the Trace record description for the minimum and medium trace depth for MAP and Diameter protocol for the C, D, Gr, Gc,Cx, Sh and S6a interfaces in the HSS.

The trace record is the same for management based activation and for signalling based activation.

Interface name	Prot. name	IE name	Message name(s)	Trace depth		Notes
				Min	Med	
D	MAP	IMSI	MAP_UPDATE_LOCATION MAP_CANCEL_LOCATION MAP_PURGE_MS MAP-INSERT-SUBSCRIBER-DATA MAP_RESTORE_DATA MAP-SEND-IMSI MAP-READY-FOR-SM	M	M	TS 29.002
		MSC Address	MAP_UPDATE_LOCATION	M	M	TS 29.002
		VLR number	MAP_UPDATE_LOCATION MAP_PURGE_MS	M	M	TS 29.002
		User error	Every message where it appears	M	M	TS 29.002
		Provider error	Every message where it appears	M	M	TS 29.002
		SGSN number	MAP_PURGE_MS	M	M	TS 29.002
		MSISDN	MAP-INSERT-SUBSCRIBER-DATA MAP-SEND-IMSI	M	M	TS 29.002
		MS Not Reachable Flag	MAP_RESTORE_DATA	M	M	TS 29.002
		SS-Code	MAP_REGISTER_SS MAP_ERASE_SS MAP_ACTIVATE_SS MAP_DEACTIVATE_SS MAP_INTERROGATE_SS MAP_REGISTER_PASSWORD MAP_REGISTER_CC_ENTRY MAP_ERASE_CC_ENTRY	M	M	TS 29.002
		Forwarded-to number with subaddress	MAP_REGISTER_SS	M	M	TS 29.002
		Alert Reason	MAP-READY-FOR-SM	M	M	TS 29.002
		Basic service	MAP_REGISTER_SS MAP_ERASE_SS MAP_ACTIVATE_SS MAP_DEACTIVATE_SS MAP_INTERROGATE_SS	M	M	TS 29.002
		C	MAP	Service Centre Address	MAP-SEND-ROUTING-INFO-FOR-SM	M
Network Node Number	MAP-SEND-ROUTING-INFO-FOR-SM			M	M	TS 29.002
GPRS Node Indicator	MAP-SEND-ROUTING-INFO-FOR-SM			M	M	TS 29.002
User error	Every message where it appears			M	M	TS 29.002
Provider error	Every message where it appears			M	M	TS 29.002
MSISDN	MAP-SEND-ROUTING-INFO-FOR-SM Send Routeing Info ack			M	M	TS 29.002
Number of forwarding	Send Routeing Info			M	M	TS 29.002 TS 23.018
IMSI	Send Routeing Info ack			M	M	TS 29.002 TS 23.018
Roaming number	Send Routeing Info ack			M	M	TS 29.002 TS 23.018

		Forwarded-to number	Send Routing Info ack	M	M	TS 29.002 TS 23.018
		Forwarding reason	Send Routing Info ack	M	M	TS 29.002 TS 23.018
		Additional Number	MAP-SEND-ROUTING-INFO-FOR-SM	M	M	TS 29.002
Gr	MAP	SGSN address	MAP_UPDATE_GPRS_LOCATION	M	M	TS 29.002
		IMSI	MAP_CANCEL_LOCATION MAP_PURGE_MS MAP_UPDATE_GPRS_LOCATION MAP-INSERT-SUBSCRIBER-DATA MAP-READY-FOR-SM	M	M	TS 29.002
		SGSN number	MAP_UPDATE_GPRS_LOCATION MAP_PURGE_MS	M	M	TS 29.002
		Alert Reason	MAP-READY-FOR-SM	M	M	TS 29.002
		User error	Every message where it appears	M	M	TS 29.002
		Provider error	Every message where it appears	M	M	TS 29.002
		Gc	MAP	IMSI	MAP_SEND_ROUTING_INFO_FOR_GPRS MAP_FAILURE_REPORT MAP_NOTE_MS_PRESENT_FOR_GPRS	M
SGSN address	MAP_SEND_ROUTING_INFO_FOR_GPRS MAP_NOTE_MS_PRESENT_FOR_GPRS			M	M	TS 29.002
GGSN address	MAP_SEND_ROUTING_INFO_FOR_GPRS MAP_FAILURE_REPORT MAP_NOTE_MS_PRESENT_FOR_GPRS			M	M	TS 29.002
Mobile Not Reachable Reason	MAP_SEND_ROUTING_INFO_FOR_GPRS			M	M	TS 29.002
User error	Every message where it appears			M	M	TS 29.002
Provider error	Every message where it appears			M	M	TS 29.002
Cx	Diameter	Public User Identity	USER-AUTHORIZATION-REQUEST MULTIMEDIA-AUTH-REQUEST LOCATION INFO REQUEST	M	M	TS 29.228
		Private User Identity	USER-AUTHORIZATION-REQUEST MULTIMEDIA-AUTH-REQUEST REGISTRATION-TERMINATION-REQUEST PUSH-PROFILE-REQUEST	M	M	TS 29.228
		Visited Network Identifier	USER-AUTHORIZATION-REQUEST	M	M	TS 29.228
		S-CSCF Name	SERVER-ASSIGNMENT-REQUEST MULTIMEDIA-AUTH-REQUEST	M	M	TS 29.228
		Server Assignment Type	SERVER-ASSIGNMENT-REQUEST	M	M	TS 29.228
		User Data Already Available	SERVER-ASSIGNMENT-REQUEST	M	M	TS 29.228
		Reason for de-registration	REGISTRATION-TERMINATION-REQUEST	M	M	TS 29.228
		Routing Information	REGISTRATION-TERMINATION-REQUEST PUSH-PROFILE-REQUEST	M	M	TS 29.228
		Number Authentication Items	MULTIMEDIA-AUTH-REQUEST	M	M	TS 29.228

		Authentication Data	MULTIMEDIA-AUTH-REQUEST	M	M	TS 29.228
		Authentication Scheme	MULTIMEDIA-AUTH-REQUEST	M	M	TS 29.228
		Registration result	SERVER-ASSIGNMENT-ANSWER	M	M	TS 29.228
		Result	USER-AUTHORIZATION-ANSWER REGISTRATION-TERMINATION-ANSWER LOCATION INFO ANSWER PUSH-PROFILE-ANSWER MULTIMEDIA-AUTH-ANSWER	M	M	TS 29.228
Sh	Diameter	User Identity	USER-DATA-REQUEST PROFILE-UPDATE-REQUEST SUBSCRIBE-NOTIFICATIONS-REQUEST PUSH-NOTIFICATION-REQUEST	M	M	TS 29.328
		Requested data	USER-DATA-REQUEST PROFILE-UPDATE-REQUEST SUBSCRIBE-NOTIFICATIONS-REQUEST	M	M	TS 29.328
		Application Server Identity	USER-DATA-REQUEST PROFILE-UPDATE-REQUEST SUBSCRIBE-NOTIFICATIONS-REQUEST	M	M	TS 29.328
		Data	PROFILE-UPDATE-REQUEST PUSH-NOTIFICATION-REQUEST	M	M	TS 29.328
		Subscription request type	SUBSCRIBE-NOTIFICATIONS-REQUEST	M	M	TS 29.328
		Result	USER-DATA-ANSWER PROFILE-UPDATE-ANSWER SUBSCRIBE-NOTIFICATIONS-ANSWER PUSH-NOTIFICATION-ANSWER	M	M	TS 29.328
S6a	Diameter	User Name	NOTIFY REQUEST AUTHENTICATION INFORMATION REQUEST DELETE SUBSCRIBER DATA REQUEST INSERT SUBSCRIBER DATA REQUEST PURGE UE REQUEST CANCEL LOCATION REQUEST UPDATE LOCATION REQUEST	M	M	TS 29.272
		Terminal Information	NOTIFY REQUEST UPDATE LOCATION REQUEST	M	M	TS 29.272
		Result	NOTIFY ANSWER AUTHENTICATION INFORMATION ANSWER DELETE SUBSCRIBER DATA ANSWER INSERT SUBSCRIBER DATA ANSWER PURGE UE ANSWER CANCEL LOCATION ANSWER UPDATE LOCATION ANSWER	M	M	TS 29.272
		RAT Type	UPDATE LOCATION REQUEST	M	M	TS 29.272
		APN	NOTIFY REQUEST			

	Visited PLMN Id	AUTHENTICATION INFORMATION REQUEST UPDATE LOCATION REQUEST	M	M	TS 29.272
--	-----------------	---	----------	----------	-----------

4.10 BM-SC Trace Record Content

The following table describes the trace record content for minimum and medium trace depth for BM-SC.

The record content is same for management based activation and for signalling based activation.

For BM-SC, the Minimum level of detail shall be supported.

Interface name	Prot. name	IE name	Message name(s)	Trace depth		Notes
				Min	Med	
Gmb	Diameter Gmb	IMSI	MBMS AUTHORIZATION REQUEST (AAR) MBMS AUTHORIZATION RESPONSE (AAA)	M	M	TS 29.061
		RAI	MBMS AUTHORIZATION REQUEST (AAR)	M	M	TS 29.061
		Access Point Name	MBMS AUTHORIZATION REQUEST (AAR)	M	M	TS 29.061
		MSISDN	MBMS AUTHORIZATION REQUEST (AAR)	M	M	TS 29.061
		IMEI(SV)	MBMS AUTHORIZATION REQUEST (AAR)	M	M	TS 29.061
		IP Multicast Address	MBMS AUTHORIZATION REQUEST (AAR)	M	M	TS 29.061
		TMGI	MBMS AUTHORIZATION RESPONSE (AAA)	M	M	TS 29.061
		Result-Code	MBMS AUTHORIZATION RESPONSE (AAA) MBMS USER DEACTIVATION RESPONSE (STA) MBMS SESSION START-STOP INDICATION RESPONSE (RAA) MBMS SERVICE TERMINATION ANSWER (ASR)	M	M	TS 29.061
		Experimental-Result	MBMS AUTHORIZATION RESPONSE (AAA) MBMS SESSION START-STOP INDICATION RESPONSE (RAA)	M	M	TS 29.061
		Error-Reporting-Host	MBMS AUTHORIZATION RESPONSE (AAA) MBMS USER DEACTIVATION RESPONSE (STA) MBMS SESSION START-STOP INDICATION RESPONSE (RAA) MBMS SERVICE TERMINATION ANSWER (ASR)	M	M	TS 29.061

4.11 PGW Trace Record Content

The following table shows the trace record content for PGW.

The trace record is the same for management based activation and for signalling based activation.

PGW shall support at least one of the following trace depth levels – Maximum, Medium or Minimum.

Table 4.11.1 : PGW Trace Record Content

Interface (specific messages)	Format	Level of details			Description
		Min	Med	Max	
S2a/S2b	Decoded	M	M	O	Message name
		O	O	O	Record extensions
		M	M	X	SGSNID of connected SGSN PGW ID of the traced PGW
		M	M	X	Dedicated IE extracted from S2a/S2b messages between the traced PGW and the SGSN. A subset of IEs as given in the table 4.11.2. is provided.
	Encoded*	X	X	M	Raw Messages: S2a/S2b messages between the traced PGW and the SGSN. The encoded content of the message is provided.
S5/S8	Decoded	M	M	O	Message name
		O	O	O	Record extensions
		M	M	X	SGW ID of the connected SGW PGW of the traced PGW
		M	M	X	IE extracted from S5/S8 messages between the traced PGW and SGW. A subset of IEs as given in the table 4.11.2. is provided.
	Encoded*	X	X	M	Raw S5/S8 Messages: messages between the traced PGW and SGW. The encoded content of the message is provided
S6b	Decoded	M	M	O	Message name
		O	O	O	Record extensions
		M	M	X	PGWID of the traced PGW
		M	M	X	Dedicated IE extracted from S6b messages between the traced PGW and the AAA. A subset of IEs as given in the table 4.11.2.is provided
	Encoded*	X	X	M	Raw S6b messages between the traced PGW and the AAA. The encoded content of the message is provided
Gx	Decoded	M	M	O	Message name
		O	O	O	Record extensions
		M	M	X	PCRF ID of the connected PCRF PGW ID of the traced PGW
		M	M	X	Dedicated IE extracted from Gx messages between the traced PGW and another PCRF. A subset of IEs as given in the table 4.11.2.is provided
	Encoded*	X	X	M	Raw Gx messages between the traced PGW and another PCRF. The encoded content of the message is provided

Encoded* - the messages are left encoded in the format it was received.

Table 4.11.2 : PGW trace record description for minimum and medium trace depth

Interface name	Prot. name	IE name	Message name(s)	Trace depth		Notes
				Min	Med	
S2a/S2b	PMIP					
S5/S8	GTPv2C	IMSI	Create Session Request Update Bearer Request	M	M	TS 29.274
		MSISDN	Create Session Request Modify Bearer Response	M	M	TS 29.274
		Serving Network	Create Session Request Modify Bearer Request	M	M	TS 29.274
		Access Point Name (APN)	Create Session Request	M	M	TS 29.274
		PDN Type	Create Session Request	M	M	TS 29.274
		Bearer Contexts	Create Session Request Create Bearer Request Create Bearer Response Delete Bearer Request Delete Bearer Response Modify Bearer Command Modify Bearer Failure Indication Update Bearer Request Update Bearer Response Delete Bearer Command Delete Bearer Failure Indication	M	M	TS 29.274

		Cause	Create Session Response Create Bearer Response Bearer Resource Failure Indication Modify Bearer Response Delete Session Response Delete Bearer Response Modify Bearer Failure Indication Update Bearer Response Delete Bearer Failure Indication	M	M	TS 29.274
		Bearer Contexts created	Create Session Response	M	M	TS 29.274
		Bearer Contexts marked for removal	Create Session Response	M	M	TS 29.274
		APN Restriction	Create Session Response	M	M	TS 29.274
		Linked Bearer Identity (LBI)	Create Bearer Request Bearer Resource Command Delete Bearer Response	M	M	TS 29.274
		Traffic Aggregate Description (TAD)	Bearer Resource Command	M	M	TS 29.274
		Linked EPS Bearer ID	Bearer Resource Failure Indication Delete Session Request Delete Bearer Request	M	M	TS 29.274
		RAT Type	Create Session Request Modify Bearer Request	M	M	TS 29.274
		Bearer Contexts to be modified	Modify Bearer Request	M	M	TS 29.274
		Bearer Contexts to be removed	Modify Bearer Request	M	M	TS 29.274
		Bearer Contexts modified		M	M	TS 29.274
		Bearer Contexts marked for removal		M	M	TS 29.274
S6b	Diameter	MIP Subscriber Profile	AAR AAA	M	M	TS 29.273
		APN	AAR	M	M	TS 29.273
		QoS capabilities	AAR	M	M	TS 29.273
		Result Code	AAA	M	M	TS 29.273
		QoS resources	AAA	M	M	TS 29.273

		3GPP AAA Server Name	AAA	M	M	TS 29.273
S2c	DSMIP					
Gx	Diameter	Bearer-Identifier	CCR	M	M	TS 29.212
		Bearer-Operation	CCR	M	M	TS 29.212
		IP-CAN-Type	CCR	M	M	TS 29.212
		RAT-Type	CCR	M	M	TS 29.212
		QoS-Information	CCR CCA RAR	M	M	TS 29.212
		QoS-Negotiation	CCR	M	M	TS 29.212
		QoS-Upgrade	CCR	M	M	TS 29.212
		Default-EPS-Bearer-QoS	CCR CCA RAR	M	M	TS 29.212
		Supported-Features	CCR CCA RAR RAA	M	M	TS 29.212
		Event-Trigger	CCR CCA RAR	M	M	TS 29.212
		Result Code	RAA	M	M	TS 29.212

	Origin-Realm	CCR CCA RAR RAA	M	M	TS 29.212
	Destination-Realm	CCR RAR	M	M	TS 29.212
SGi					

4.12 MME Trace Record Content

The following table shows the trace record content for MME.

The trace record is the same for management based activation and for signalling based activation.

MME shall support at least one of the following trace depth levels – Maximum, Medium or Minimum.

Table 4.12.1 : MME Trace Record Content

Interface (specific messages)	Format	Level of details			Description
		Min	Med	Max	
S1	Decoded	M	M	O	Message name
		O	O	O	Record extensions
		M	M	X	eNBID of connected eNB MME ID of the traced MME
		M	M	X	Dedicated IE extracted from S1 messages between the traced eNB and the MME. A subset of IEs as given in the table 4.12.2. is provided.
	ASN.1	X	X	M	Raw Messages: S1 messages between the traced eNB and the MME. The encoded content of the message is provided.
S1 NAS PDU IE	3GPP TS 24.301, sections 8 and 9	X	X	M	Hexdata dump of the decrypted NAS message formatted according to 3GPP TS 24.301, sections 8 and 9, recorded as a separate message entry in the call trace file
S3	Decoded	M	M	O	Message name
		O	O	O	Record extensions
		M	M	X	SGSN ID of the connected SGSN MME ID of the traced MME
		M	M	X	IE extracted from S3 messages between the traced MME and SGSN. A subset of IEs as given in the table 4.12.2. is provided.
	Encoded *	X	X	M	Raw S3 Messages: messages between the traced MME and SGSN. The encoded content of the message is provided
S11	Decoded	M	M	O	Message name
		O	O	O	Record extensions
		M	M	X	SGW ID of the connected SGW MME ID of the traced MME
		M	M	X	Dedicated IE extracted from S11 messages between the traced SGW and the MME. A subset of IEs as given in the table 4.12.2.is provided
	Encoded *	X	X	M	Raw S11 messages between the traced SGW and the MME. The encoded content of the message is provided
S6a	Decoded	M	M	O	Message name
		O	O	O	Record extensions
		M	M	X	HSS ID of the connected HSS MME ID of the traced MME
		M	M	X	Dedicated IE extracted from S6a messages between the traced HSS and the MME. A subset of IEs as given in the table 4.12.2.is provided
	Encoded *	X	X	M	Raw S6a messages between the traced HSS and the MME. The encoded content of the message is provided
S10	Decoded	M	M	O	Message name
		O	O	O	Record extensions
		M	M	X	MME ID of the connected MME MME ID of the traced MME
		M	M	X	Dedicated IE extracted from S10 messages between the traced MME and another MME. A subset of IEs as given in the table 4.12.2.is provided
	Encoded *	X	X	M	Raw S10 messages between the traced MME and another MME. The encoded content of the message is provided

Encoded* - the messages are left encoded in the format it was received.

Table 4.12.2 : MME trace record description for minimum and medium trace depth

Interface name	Prot. name	IE name	Message name(s)	Trace depth		Notes
				Min	Med	
S1	MM	EPS attach type	ATTACH REQUEST	M	M	TS 24.301
		GUTI	ATTACH REQUEST ATTACH ACCEPT TRACKING AREA UPDATE REQUEST TRACKING AREA UPDATE ACCEPT DETACH REQUEST GUTI REALLOCATION COMMAND	M	M	TS 24.301
		IMSI	ATTACH REQUEST DETACH REQUEST	M	M	TS 24.301
		Old P-TMSI	ATTACH REQUEST TRACKING AREA UPDATE REQUEST	M	M	TS 24.301
		M-TMSI		M	M	TS 24.301
		Last visited registered TAI	ATTACH REQUEST TRACKING AREA UPDATE REQUEST	M	M	TS 24.301
		UE network capability	ATTACH REQUEST TRACKING AREA UPDATE REQUEST	M	M	TS 24.301
		MS network capability	ATTACH REQUEST	M	M	TS 24.301
		LAI	ATTACH REQUEST ATTACH ACCEPT TRACKING AREA UPDATE REQUEST TRACKING AREA UPDATE ACCEPT	M	M	TS 24.301
		EPS attach result	ATTACH ACCEPT	M	M	TS 24.301
		EMM cause	ATTACH ACCEPT ATTACH REJECT TRACKING AREA UPDATE ACCEPT TRACKING AREA UPDATE REJECT DETACH REQUEST AUTHENTICATION FAILURE SERVICE REJECT SECURITY MODE REJECT EMM STATUS	M	M	TS 24.301
		EPS bearer context status	TRACKING AREA UPDATE REQUEST TRACKING AREA UPDATE ACCEPT	M	M	TS 24.301
		Detach type	DETACH REQUEST	M	M	TS 24.301
		EPS update type	TRACKING AREA UPDATE REQUEST	M	M	TS 24.301
		EPS update result	TRACKING AREA UPDATE ACCEPT	M	M	TS 24.301
		Identity type	IDENTITY REQUEST	M	M	TS 24.301
		Mobile identity	IDENTITY RESPONSE	M	M	TS 24.301
		IMEISV request	SECURITY MODE COMMAND	M	M	TS 24.301
		IMEISV	SECURITY MODE COMPLETE	M	M	TS 24.301
		Selected NAS security algorithms	SECURITY MODE COMMAND	M	M	TS 24.301
		UE security capability	SECURITY MODE COMMAND	M	M	TS 24.301
		Equivalent PLMNs list	ATTACH ACCEPT TRACKING AREA UPDATE ACCEPT	M	M	TS 24.301
		TAI list	ATTACH ACCEPT TRACKING AREA UPDATE ACCEPT GUTI REALLOCATION COMMAND	M	M	TS 24.301

S1	SM	EPS bearer identity	PDN CONNECTIVITY REQUEST PDN CONNECTIVITY REJECT PDN DISCONNECT REQUEST PDN DISCONNECT REJECT ACTIVATE DEFAULT EPS BEARER CONTEXT REQUEST ACTIVATE DEFAULT EPS BEARER CONTEXT ACCEPT ACTIVATE DEFAULT EPS BEARER CONTEXT REJECT ACTIVATE DEDICATED EPS BEARER CONTEXT REQUEST ACTIVATE DEDICATED EPS BEARER CONTEXT ACCEPT ACTIVATE DEDICATED EPS BEARER CONTEXT REJECT ESM STATUS DEACTIVATE EPS BEARER CONTEXT REQUEST DEACTIVATE EPS BEARER CONTEXT ACCEPT MODIFY EPS BEARER CONTEXT REQUEST MODIFY EPS BEARER CONTEXT ACCEPT MODIFY EPS BEARER CONTEXT REJECT BEARER RESOURCE ALLOCATION REQUEST BEARER RESOURCE ALLOCATION REJECT BEARER RESOURCE MODIFICATION REQUEST BEARER RESOURCE MODIFICATION REJECT	M	M	TS 24.301
		Linked EPS bearer identity	PDN DISCONNECT REQUEST ACTIVATE DEDICATED EPS BEARER CONTEXT REQUEST BEARER RESOURCE ALLOCATION REQUEST BEARER RESOURCE MODIFICATION REQUEST	M	M	TS 24.301
		Procedure Transaction Identity	PDN CONNECTIVITY REQUEST PDN CONNECTIVITY REJECT PDN DISCONNECT REQUEST PDN DISCONNECT REJECT ACTIVATE DEFAULT EPS BEARER CONTEXT REQUEST ACTIVATE DEFAULT EPS BEARER CONTEXT ACCEPT ACTIVATE DEFAULT EPS BEARER CONTEXT REJECT ACTIVATE DEDICATED EPS BEARER CONTEXT REQUEST ACTIVATE DEDICATED EPS BEARER CONTEXT ACCEPT ACTIVATE DEDICATED EPS BEARER CONTEXT REJECT ESM STATUS DEACTIVATE EPS BEARER CONTEXT REQUEST DEACTIVATE EPS BEARER CONTEXT ACCEPT MODIFY EPS BEARER CONTEXT REQUEST MODIFY EPS BEARER CONTEXT ACCEPT MODIFY EPS BEARER CONTEXT REJECT BEARER RESOURCE ALLOCATION REQUEST BEARER RESOURCE ALLOCATION REJECT BEARER RESOURCE MODIFICATION REQUEST BEARER RESOURCE MODIFICATION REJECT	M	M	TS 24.301
		Request type	PDN CONNECTIVITY REQUEST	M	M	TS 24.301
		APN	PDN CONNECTIVITY REQUEST ACTIVATE DEFAULT EPS BEARER CONTEXT REQUEST	M	M	TS 24.301
		EPS QoS	ACTIVATE DEFAULT EPS BEARER CONTEXT REQUEST ACTIVATE DEDICATED EPS BEARER CONTEXT REQUEST MODIFY EPS BEARER CONTEXT REQUEST	M	M	TS 24.301
		Negotiated QoS/New QoS	ACTIVATE DEFAULT EPS BEARER CONTEXT REQUEST ACTIVATE DEDICATED EPS BEARER CONTEXT REQUEST MODIFY EPS BEARER CONTEXT REQUEST	M	M	TS 24.301

		PDN address	ACTIVATE DEFAULT EPS BEARER CONTEXT REQUEST	M	M	TS 24.301
		APN-AMBR	ACTIVATE DEFAULT EPS BEARER CONTEXT REQUEST MODIFY EPS BEARER CONTEXT REQUEST	M	M	TS 24.301
		ESM cause	PDN CONNECTIVITY REJECT PDN DISCONNECT REJECT ACTIVATE DEFAULT EPS BEARER CONTEXT REQUEST ACTIVATE DEFAULT EPS BEARER CONTEXT REJECT ACTIVATE DEDICATED EPS BEARER CONTEXT REJECT ESM STATUS DEACTIVATE EPS BEARER CONTEXT REQUEST MODIFY EPS BEARER CONTEXT REJECT BEARER RESOURCE ALLOCATION REJECT BEARER RESOURCE MODIFICATION REQUEST BEARER RESOURCE MODIFICATION REJECT	M	M	TS 24.301
		Traffic flow template	ACTIVATE DEDICATED EPS BEARER CONTEXT REQUEST MODIFY EPS BEARER CONTEXT REQUEST	M	M	TS 24.301
		Traffic flow aggregate	BEARER RESOURCE ALLOCATION REQUEST BEARER RESOURCE MODIFICATION REQUEST	M	M	TS 24.301
		Required traffic flow QoS	BEARER RESOURCE ALLOCATION REQUEST BEARER RESOURCE MODIFICATION REQUEST	M	M	TS 24.301
		PDN type	PDN CONNECTIVITY REQUEST	M	M	TS 24.301
		S3	GTPv2-C	IMSI	DETACH NOTIFICATION CS PAGING INDICATON	M
TMSI	CS PAGING INDICATON			M	M	TS 29.274
Cause	DETACH NOTIFICATION DETACH ACKNOWLEDGE			M	M	TS 29.274
S3/S10	GTPv2-C	IMSI	RELOCATION CANCEL REQUEST IDENTIFICATION RESPONSE CONTEXT RESPONSE CONTEXT REQUEST FORWARD RELOCATION REQUEST	M	M	TS 29.274
		GUTI	CONTEXT REQUEST IDENTIFICATION REQUEST	M	M	TS 29.274
		RAI	IDENTIFICATION REQUEST CONTEXT REQUEST	M	M	TS 29.274
		P-TMSI	IDENTIFICATION REQUEST CONTEXT REQUEST	M	M	TS 29.274
		Indication	FORWARD RELOCATION COMPLETE NOTIFICATION FORWARD RELOCATION REQUEST	M	M	TS 29.274
		BSSGP Cause	FORWARD RELOCATION RESPONSE FORWARD RELOCATION REQUEST	M	M	TS 29.274
		RANAP Cause	FORWARD RELOCATION RESPONSE FORWARD RELOCATION REQUEST	M	M	TS 29.274
		eNodeB Cause	FORWARD RELOCATION RESPONSE	M	M	TS 29.274
		RAT Type	CONTEXT REQUEST	M	M	TS 29.274
Target Identification	FORWARD RELOCATION REQUEST	M	M	TS 29.274		

		Cause	RELOCATION CANCEL RESPONSE FORWARD SRNS CONTEXT ACKNOWLEDGE IDENTIFICATION RESPONSE CONTEXT ACKNOWLEDGE CONTEXT RESPONSE FORWARD RELOCATION COMPLETE ACKNOWLEDGE FORWARD RELOCATION RESPONSE	M	M	TS 29.274
		RAN Cause	FORWARD RELOCATION REQUEST	M	M	TS 29.274
		Selected PLMN ID	FORWARD RELOCATION REQUEST	M	M	TS 29.274
S6a	Diameter	User Name	NOTIFY REQUEST AUTHENTICATION INFORMATION REQUEST DELETE SUBSCRIBER DATA REQUEST INSERT SUBSCRIBER DATA REQUEST PURGE UE REQUEST CANCEL LOCATION REQUEST UPDATE LOCATION REQUEST	M	M	TS 29.272
		Terminal Information	NOTIFY REQUEST UPDATE LOCATION REQUEST	M	M	TS 29.272
		Result	NOTIFY ANSWER AUTHENTICATION INFORMATION ANSWER DELETE SUBSCRIBER DATA ANSWER INSERT SUBSCRIBER DATA ANSWER PURGE UE ANSWER CANCEL LOCATION ANSWER UPDATE LOCATION ANSWER	M	M	TS 29.272
		RAT Type	UPDATE LOCATION REQUEST	M	M	TS 29.272
		APN	NOTIFY REQUEST			
		Visited PLMN Id	AUTHENTICATION INFORMATION REQUEST UPDATE LOCATION REQUEST	M	M	TS 29.272
S11	GTPv2-C	IMSI	CREATE SESSION REQUEST CHANGE NOTIFICATION REQUEST CHANGE NOTIFICATION RESPONSE SUSPEND NOTIFICATION SUSPEND ACKNOWLEDGE RESUME NOTIFICATION RESUME ACKNOWLEDGE	M	M	TS 29.274
		APN	CREATE SESSION REQUEST	M	M	TS 29.274
		Indication Flags	MODIFY BEARER REQUEST DELETE SESSION REQUEST	M	M	TS 29.274
		EPS Bearer ID	CREATE SESSION RESPONSE CREATE BEARER RESPONSE MODIFY BEARER REQUEST MODIFY BEARER RESPONSE DELETE BEARER REQUEST DELETE BEARER RESPONSE UPDATE USER PLANE RESPONSE MODIFY BEARER COMMAND MODIFY BEARER FAILURE INDICATION UPDATE BEARER RESPONSE DELETE BEARER FAILURE INDICATION CREATE INDIRECT DATA FORWARDING TUNNEL RESPONSE UPDATE BEARER COMPLETE	M	M	TS 29.274

		MME-CSID	CREATE SESSION REQUEST CREATE BEARER RESPONSE DELETE BEARER RESPONSE	M	M	TS 29.274
		SGW-CSID	CREATE SESSION REQUEST CREATE SESSION RESPONSE CREATE BEARER REQUEST CREATE BEARER RESPONSE DELETE BEARER REQUEST DELETE BEARER RESPONSE	M	M	TS 29.274
		MSISDN	CREATE SESSION REQUEST MODIFY BEARER RESPONSE	M	M	TS 29.274
		Bearer Level QoS	CREATE SESSION REQUEST CREATE BEARER REQUEST MODIFY BEARER REQUEST MODIFY BEARER RESPONSE MODIFY BEARER COMMAND UPDATE BEARER REQUEST	M	M	TS 29.274
		RAT Type	CREATE SESSION REQUEST MODIFY BEARER REQUEST CHANGE NOTIFICATION REQUEST	M	M	TS 29.274
		MEI	CREATE SESSION REQUEST MODIFY BEARER REQUEST	M	M	TS 29.274
		Cause	CREATE SESSION RESPONSE CREATE BEARER RESPONSE BEARER RESOURCE FAILURE INDICATION MODIFY BEARER RESPONSE DELETE SESSION RESPONSE DELETE BEARER RESPONSE DOWNLINK DATA NOTIFICATION ACKNOWLEDGEMENT DOWNLINK DATA NOTIFICATION INDICATION UPDATE USER PLANE RESPONSE MODIFY BEARER FAILURE INDICATION UPDATE BEARER RESPONSE DELETE BEARER FAILURE INDICATION CREATE INDIRECT DATA FORWARDING TUNNEL RESPONSE UPDATE BEARER COMPLETE CHANGE NOTIFICATION RESPONSE CREATE FORWARDING TUNNEL RESPONSE	M	M	TS 29.274
		PGW-CSID	CREATE BEARER REQUEST DELETE BEARER REQUEST	M	M	TS 29.274
S1	S1AP	E-RAB ID	All messages where it is present	M	M	TS 36.413
		E-RAB Level QoS Parameters	E-RAB SETUP REQUEST E-RAB MODIFY REQUEST INITIAL CONTEXT SETUP REQUEST	M	M	TS 36.413

		Cause	INITIAL CONTEXT SETUP FAILURE UE CONTEXT RELEASE REQUEST UE CONTEXT RELEASE COMMAND UE CONTEXT MODIFICATION FAILURE HANDOVER REQUIRED HANDOVER PREPARATION FAILURE HANDOVER REQUEST HANDOVER FAILURE HANDOVER CANCEL PATH SWITCH REQUEST FAILURE NAS NON DELIVERY INDICATION	M	M	TS 36.413
		Handover Type	HANDOVER REQUIRED HANDOVER COMMAND HANDOVER REQUEST	M	M	TS 36.413
		E-UTRAN CGI	HANDOVER NOTIFY PATH SWITCH REQUEST INITIAL UE MESSAGE UPLINK NAS TRANSPORT	M	M	TS 36.413
		TAI	HANDOVER NOTIFY PATH SWITCH REQUEST UPLINK NAS TRANSPORT PAGING	M	M	TS 36.413
		Target ID	HANDOVER REQUIRED	M	M	TS 36.413
		CDMA2000 HO Status	DOWNLINK S1 CDMA2000 TUNNELING	M	M	TS 36.413
		CDMA2000 RAT Type	DOWNLINK S1 CDMA2000 TUNNELING UPLINK S1 CDMA2000 TUNNELING	M	M	TS 36.413
		CDMA2000 Sector ID	UPLINK S1 CDMA2000 TUNNELING	M	M	TS 36.413
		CDMA2000 HO Required Indication	UPLINK S1 CDMA2000 TUNNELING	M	M	TS 36.413
		S13	Diameter	Terminal Information	ME Identity Check Request	M
Result	ME Identity Check Answer			M	M	TS 29.272

4.13 E-UTRAN Trace Record Content

For eNB, the Maximum level of detail shall be supported.

Table 4.13.1 : E-UTRAN Trace Record Content

Interface (specific messages)	Format	Level of details			Description
		Min	Med	Max	
RRC (without rrc dedicated measurements)	Decoded	M	M	O	Message name
		O	O	O	Record extensions
		M	M	X	eNBID of traced eNB
		M	M	X	Dedicated IE extracted from RRC messages between the traced eNB and the UE. A subset of IEs as given in the table 4.13.2. is provided.
	ASN.1	X	X	M	Raw Uu Messages: RRC messages between the traced eNB and the UE. The encoded content of the message is provided
S1	Decoded	M	M	O	Message name
		O	O	O	Record extensions
		M	M	X	eNBID of traced eNB MME ID of the connected MME
		M	M	X	E-RabId + Dedicated IE extracted from S1AP messages between the traced eNB and Core Network. A subset of IEs as given in the table 4.13.2. is provided.
	ASN.1	X	X	M	Raw S1 Messages S1AP: messages between the traced eNB and Core Network The encoded content of the message is provided
X2	Decoded	M	M	O	Message name
		O	O	O	Record extensions
		M	M	X	eNBID of traced eNB eNBID of neighbouring eNB
		M	M	X	Dedicated IE extracted from X2AP messages between the traced eNB and the neighbouring eNB. A subset of IEs as given in the table 4.13.2.is provided
	ASN.1	X	X	M	Raw X2 Messages:X2AP messages between the traced eNB and the neighbouring eNB. The encoded content of the message is provided
RRC (only dedicated measurements)	Decoded	X	M	X	Uu IEs from RRC measurement reports messages
	ASN.1	X	X	M	RRC measurement reports messages

NOTE: For the security keys in IEs or part of IEs that are containing security keys used by the eNB (e.g. K_{eNB}), the value 0 shall be written in the trace file.

Definitions:

- eNBID of traced eNB: The id of the eNB traced, e.g. the eNB which handles the connection of the traced MS, during the Trace Recording Session.
- eNBID of neighbouring eNB: The ids of all Neighbouring eNB involved in the X2 procedures during the Trace Recording Session.
- cell Id: The cell Ids of the cells involved in the X2 procedures during the Trace Recording Session. The cell Ids is provided with each X2AP messages for which the cId is relevant.
- E-RABId: Specific recorded IE that contains the E-RAB identifier.
- Message name: Name of the protocol message
- Record extensions: A set of manufacturer specific extensions to the record
- Decoded: Some IEs shall be decoded (cf. detailed list in table 4.6.2. depending on trace depth)
- ASN.1: Messages in encoded format

Table 4.13.2 : trace record description for minimum and medium trace depth

Interface name	Prot. name	IE name	Message name(s)	Trace depth		Notes
				Min	Med	
Uu	RRC	Cs fallback indicator	MOBILITY FROM EUTRA COMMAND	M	M	TS 36.331
		CN domain	PAGING	O	O	TS 36.331
		S-TMSI	PAGING	O	O	TS 36.331
		ReestablishmentCause	RRC CONNECTION REESTABLISHMENT REQUEST	M	M	TS 36.331
		Wait time	RRC CONNECTION REJECT	CM	CM	TS 36.331
		Release Cause	RRC CONNECTION RELEASE	M	M	TS 36.331
		Redirection Information	RRC CONNECTION RELEASE	M	M	TS 36.331
		Establishment Cause	RRC CONNECTION REQUEST	CM	CM	TS 36.331
		Selected PLMN-Identity	RRC CONNECTION SETUP COMPLETE	CM	CM	TS 36.331
		RegisteredMME	RRC CONNECTION SETUP COMPLETE	CM	CM	TS 36.331
		Rat-Type	UE CAPABILITY INFORMATION	M	M	TS 36.331
		Measured Results	MEASUREMENT REPORT	X	M	TS 36.331
		CDMA2000-Type	HANDOVER FROM EUTRA PREPARATION REQUEST UL HANDOVER PREPARATION TRANSFER	M	M	TS 36.331
		Target RAT Type	MOBILITY FROM EUTRA COMMAND	M	M	TS 36.331
S1	S1AP	E-RAB ID	All messages where it is present	M	M	TS 36.413
		E-RAB Level QoS Parameters	E-RAB SETUP REQUEST E-RAB MODIFY REQUEST INITIAL CONTEXT SETUP REQUEST	M	M	TS 36.413
		Cause	INITIAL CONTEXT SETUP FAILURE UE CONTEXT RELEASE REQUEST UE CONTEXT RELEASE COMMAND UE CONTEXT MODIFICATION FAILURE HANDOVER REQUIRED HANDOVER PREPARATION FAILURE HANDOVER REQUEST HANDOVER FAILURE HANDOVER CANCEL PATH SWITCH REQUEST FAILURE NAS NON DELIVERY INDICATION	M	M	TS 36.413
		Handover Type	HANDOVER REQUIRED HANDOVER COMMAND HANDOVER REQUEST	M	M	TS 36.413

		E-UTRAN CGI	HANDOVER NOTIFY PATH SWITCH REQUEST INITIAL UE MESSAGE UPLINK NAS TRANSPORT	CM	CM	TS 36.413
		TAI	HANDOVER NOTIFY PATH SWITCH REQUEST UPLINK NAS TRANSPORT	M	M	TS 36.413
		Target ID	HANDOVER REQUIRED	M	M	TS 36.413
		CDMA2000 HO Status	DOWNLINK S1 CDMA2000 TUNNELING	M	M	TS 36.413
		CDMA2000 RAT Type	DOWNLINK S1 CDMA2000 TUNNELING UPLINK S1 CDMA2000 TUNNELING	M	M	TS 36.413
		CDMA2000 Sector ID	UPLINK S1 CDMA2000 TUNNELING	M	M	TS 36.413
		CDMA2000 HO Required Indication	UPLINK S1 CDMA2000 TUNNELING	M	M	TS 36.413
X2	X2AP	E-RAB id	All messages where it is present	M	M	TS 36.423
		E-RAB Level QoS	HANDOVER REQUEST	M	M	TS 36.423
		Cause	HANDOVER REQUEST HANDOVER PREPARATION FAILURE HANDOVER CANCEL	M	M	TS 36.423
		Target Cell ID	HANDOVER REQUEST	M	M	TS 36.423
		GUMMEI	HANDOVER REQUEST	M	M	TS 36.423
		UE History Information	HANDOVER REQUEST	M	M	TS 36.423

Constraints:

The condition for capturing the following Information Element is that Cell Traffic Trace is used:

- Wait time from RRC protocol
- Establishment Cause from RRC protocol
- Selected PLMN-Identity from RRC protocol
- RegisteredMME from RRC protocol
- E-UTRAN CGI from S1 interface from the following messages: Initial UE message, Handover Notify

4.14 SGW Trace Record Content

The following table shows the trace record content for SGW.

The trace record is the same for management based activation and for signalling based activation.

SGW shall support at least one of the following trace depth levels – Maximum, Medium or Minimum.

Table 4.14.1 : SGW Trace Record Content

Interface (specific messages)	Format	Level of details			Description
		Min	Med	Max	
S11	Decoded	M	M	O	Message name
		O	O	O	Record extensions
		M	M	X	MME ID of the connected MME SGW ID of the traced SGW
		M	M	X	Dedicated IE extracted from S11 messages between the traced MME and the SGW. A subset of IEs as given in the table 4.14.2.is provided
	Encoded*	X	X	M	Raw S11 messages between the traced MME and the SGW. The encoded content of the message is provided
S5/S8	Decoded	M	M	O	Message name
		O	O	O	Record extensions
		M	M	X	PGW ID of the connected PGW SGW of the traced SGW
		M	M	X	IE extracted from S5/S8 messages between the traced SGW and PGW. A subset of IEs as given in the table 4.14.2. is provided.
	Encoded*	X	X	M	Raw S5/S8 Messages: messages between the traced SGW and PGW. The encoded content of the message is provided
S4	Decoded	M	M	O	Message name
		O	O	O	Record extensions
		M	M	X	SGSNID of the connected SGSN SGWID of the traced SGW
		M	M	X	Dedicated IE extracted from S4 messages between the traced SGW and the SGSN. A subset of IEs as given in the table 4.14.2.is provided
	Encoded*	X	X	M	Raw S4 messages between the traced PGW and the AAA. The encoded content of the message is provided
Gxc	Decoded	M	M	O	Message name
		O	O	O	Record extensions
		M	M	X	PCRF ID of the connected PCRF SGW ID of the traced SGW
		M	M	X	Dedicated IE extracted from Gx messages between the traced SGW and another PCRF. A subset of IEs as given in the table 4.14.2.is provided
	Encoded*	X	X	M	Raw Gx messages between the traced SGW and another PCRF. The encoded content of the message is provided

Encoded* - the messages are left encoded in the format it was received.

Table 4.14.2 : SGW trace record description for minimum and medium trace depth

Interface name	Prot. name	IE name	Message name(s)	Trace depth		Notes
				Min	Med	
S11	GTPv2C	IMSI	Create Session Request Suspend Notification Suspend Acknowledge Resume Notification Resume Acknowledge	M	M	TS 29.274
		MSISDN	Create Session Request Modify Bearer Response	M	M	TS 29.274
		RAT type	Create Session Request Modify Bearer Request	M	M	TS 29.274
		Serving Network	Create Session Request Modify Bearer Request	M	M	TS 29.274
		Access Point Name (APN)	Create Session Request	M	M	TS 29.274
		PDN Type	Create Session Request	M	M	TS 29.274
		Bearer Contexts	Create Session Request Create Bearer Request Create Bearer Response Delete Bearer Request Delete Bearer Response Modify Bearer Command Modify Bearer Failure Indication Update Bearer Request Update Bearer Response Delete Bearer Command Delete Bearer Failure Indication Create Indirect Data Forwarding Tunnel Request Create Indirect Data Forwarding Tunnel Response Update Bearer Complete	M	M	TS 29.274
		Cause	Create Session Response Create Bearer Response Bearer Resource Failure Indication Modify Bearer Response Delete Session Response Downlink Data Notification Acknowledgement Downlink Data Notification Failure Indication Modify Bearer Failure Indication Update Bearer Response Delete Bearer Failure Indication Create Indirect Data Forwarding Tunnel Response Update Bearer Complete	M	M	TS 29.274
		Bearer Contexts created	Create Session Response	M	M	TS 29.274
		APN Restriction	Create Session Response	M	M	TS 29.274
		Linked Bearer Identity (LBI)	Create Bearer Request Bearer Resource Command Delete Session Request Delete Bearer Request Delete Bearer Response	M	M	TS 29.274
		Traffic Aggregate Description (TAD)	Bearer Resource Command	M	M	TS 29.274
		Linked EPS Bearer ID	Bearer Resource Command	M	M	TS 29.274
		Bearer Contexts to be removed	Modify Bearer Request	M	M	TS 29.274
		Bearer Contexts modified	Modify Bearer Response	M	M	TS 29.274
Bearer Contexts marked for removal	Modify Bearer Response Update User Plane Response	M	M	TS 29.274		

		Bearer Contexts to be updated	Update User Plane Request	M	M	TS 29.274
		Bearer Contexts to be removed	Update User Plane Request	M	M	TS 29.274
		Bearer Contexts updated	Update User Plane Response	M	M	TS 29.274
		Bearer Contexts to be modified	Modify Bearer Request	M	M	TS 29.274
S4	GTPv2C	Traffic Aggregate Description (TAD)	Bearer Resource Command	M	M	TS 29.274
		Linked Bearer Identity (LBI)	Bearer Resource Command Create Bearer Request Delete Bearer Response	M	M	TS 29.274
		Linked EPS Bearer ID	Bearer Resource Failure Indication Delete Session Request Delete Bearer Request	M	M	TS 29.274
		Cause	Bearer Resource Failure Indication Create Session Response Create Bearer Response Modify Bearer Response Delete Session Response Delete Bearer Response Downlink Data Notification Acknowledgement Downlink Data Notification Failure Indication Update Bearer Response Create Indirect Data Forwarding Tunnel Response Update Bearer Complete	M	M	TS 29.274
		Bearer Contexts to be modified	Modify Bearer Request	M	M	TS 29.274
		Bearer Contexts to be removed	Modify Bearer Request	M	M	TS 29.274
		IMSI	Create Session Request Update Bearer Request	M	M	TS 29.274
		MSISDN	Create Session Request Modify Bearer Response	M	M	TS 29.274
		Serving Network	Create Session Request	M	M	TS 29.274
		Access Point Name (APN)	Create Session Request	M	M	TS 29.274
		PDN Type	Create Session Request	M	M	TS 29.274
		Bearer Contexts	Create Session Request Create Bearer Request Create Bearer Response Delete Bearer Request Delete Bearer Response Update Bearer Request Update Bearer Response Create Indirect Data Forwarding Tunnel Request Create Indirect Data Forwarding Tunnel Response Update Bearer Complete	M	M	TS 29.274
		RAT Type	Create Session Request Modify Bearer Request	M	M	TS 29.274
		Bearer Contexts created	Create Session Response	M	M	TS 29.274
		Bearer Contexts marked for removal	Create Session Response	M	M	TS 29.274
		Bearer Contexts modified	Modify Bearer Response	M	M	TS 29.274
		Bearer Contexts marked for removal	Modify Bearer Response	M	M	TS 29.274
S5/S8	GTPv2C	IMSI	Create Session Request Update Bearer Request	M	M	TS 29.274

		MSISDN	Create Session Request Modify Bearer Response	M	M	TS 29.274
		Serving Network	Create Session Request Modify Bearer Request	M	M	TS 29.274
		Access Point Name (APN)	Create Session Request	M	M	TS 29.274
		PDN Type	Create Session Request	M	M	TS 29.274
		Bearer Contexts	Create Session Request Create Bearer Request Create Bearer Response Delete Bearer Request Delete Bearer Response Modify Bearer Command Modify Bearer Failure Indication Update Bearer Request Update Bearer Response Delete Bearer Command Delete Bearer Failure Indication	M	M	TS 29.274
		Cause	Create Session Response Create Bearer Response Bearer Resource Failure Indication Modify Bearer Response Delete Session Response Delete Bearer Response Modify Bearer Failure Indication Update Bearer Response Delete Bearer Failure Indication	M	M	TS 29.274
		Bearer Contexts created	Create Session Response	M	M	TS 29.274
		Bearer Contexts marked for removal	Create Session Response	M	M	TS 29.274
		APN Restriction	Create Session Response	M	M	TS 29.274
		Linked Bearer Identity (LBI)	Create Bearer Request Bearer Resource Command Delete Bearer Response	M	M	TS 29.274
		Traffic Aggregate Description (TAD)	Bearer Resource Command	M	M	TS 29.274
		Linked EPS Bearer ID	Bearer Resource Failure Indication Delete Session Request Delete Bearer Request	M	M	TS 29.274
		RAT Type	Create Session Request Modify Bearer Request	M	M	TS 29.274
		Bearer Contexts to be modified	Modify Bearer Request	M	M	TS 29.274
		Bearer Contexts to be removed	Modify Bearer Request	M	M	TS 29.274
		Bearer Contexts modified		M	M	TS 29.274
		Bearer Contexts marked for removal		M	M	TS 29.274
Gxc	Diameter	IP-CAN-Type	CCR	M	M	TS 29.212
		RAT-Type	CCR	M	M	TS 29.212
		QoS-Information	CCR CCA RAR	M	M	TS 29.212
		QoS-Negotiation	CCR	M	M	TS 29.212
		QoS-Rule-Report	CCR RAA	M	M	TS 29.212
		Default-EPS-Bearer-QoS	CCR CCA RAR	M	M	TS 29.212

	Supported-Features	CCR CCA RAR RAA	M	M	TS 29.212
	Event-Trigger	CCR CCA RAR	M	M	TS 29.212
	Result Code	RAA	M	M	TS 29.212
	Origin-Realm	CCR CCA RAR RAA	M	M	TS 29.212
	QoS-Rule-Remove	RAR CAA	M	M	TS 29.212
	QoS-Rule-Install	RAR CAA	M	M	TS 29.212
	Destination-Realm	CCR RAR	M	M	TS 29.212

4.15 EIR Trace Record Content

The following table contains the Trace record description for the minimum and medium trace depth for MAP(F), S13, S13', MAP(Gf) interfaces in the EIR.

The trace record is the same for management based activation and for signalling based activation.

Interface name	Prot. name	IE name	Message name(s)	Trace depth		Notes
				Min	Med	
F	MAP	IMEI(SV)	MAP_CHECK_IMEI	M	M	TS 29.002 TS 23.018
		Equipment status	MAP_CHECK_IMEI	M	M	TS 29.002 TS 23.018
		User error	Every message where it appears	M	M	TS 29.002
		Provider error	Every message where it appears	M	M	TS 29.002
S13/S13'	Diameter	Terminal Information	ME Identity Check Request	M	M	TS 29.272
		Result	ME Identity Check Answer	M	M	TS 29.272
Gf	MAP	IMEI(SV)	MAP_CHECK_IMEI	M	M	TS 29.002
		Equipment status	MAP_CHECK_IMEI	M	M	TS 29.002
		User error	Every message where it appears	M	M	TS 29.002
		Provider error	Every message where it appears	M	M	TS 29.002

Annex A (normative): Trace Report File Format

This annex describes the format of trace or MDT result files. Those files are to be transferred from the network (NEs or EM) to the NM.

The following conditions have been considered for the definition of this file format:

- The trace data volume and trace duration is not predictable. Depending on the data retrieval and storage mechanisms, several consecutive trace result files could be generated for a single traced call. The file naming convention shall allow rebuilding the temporal file sequences.
- Since the files are transferred via a machine-machine interface, the files should be machine-readable using standard tools.
- The file format should be independent from the data transfer protocol used to carry the file from one system to another.
- The file format should be generic across UMTS and EPS systems.
- The file format should be flexible enough to support further trace data types and decoded IEs, as well as vendor specific trace data.

A.1 Parameter description and mapping table

The following table describes the XML trace file parameters.

Table : XML trace file parameters

XML element / XML attribute specification	Description
traceCollecFile	This is the top-level element. It identifies the file as a collection of trace or MDT data. This element includes: <ul style="list-style-type: none"> - a file header (element "fileHeader") - the collection of trace data items (elements "traceRecSession").
fileHeader	This is the trace file header element. This element includes: <ul style="list-style-type: none"> - a version indicator (attribute specification "fileFormatVersion") - the vendor name of the sending network node (attribute specification "vendorName") - the name of the sending network node (attribute specification "fileSender elementDn") - the type of the sending network node (attribute specification "fileSender elementType") - a time stamp (attribute specification "traceCollec beginTime").
fileHeader fileFormatVersion	This attribute specification identifies the file format version applied by the sender. The format version defined in the present document shall be the abridged number and version of this 3GPP document (see below). The abridged number and version of a 3GPP document is constructed from its version specific full reference "3GPP [...] (YYYY-mm)" by: <ul style="list-style-type: none"> - removing the leading "3GPP TS" - removing everything including and after the version third digit, representing editorial only changes, together with its preceding dot character - from the resulting string, removing leading and trailing white space, replacing every multi character white space by a single space character and changing the case of all characters to uppercase.
fileHeader vendorName	Optional attribute specification that has the following value part: vendor of the equipment that provided the trace file.
fileSender elementDn	Optional attribute specification that uniquely identifies the NE or EM that assembled this trace file, according to the definitions in 3GPP TS 32.300 [11].
fileSender elementType	Optional attribute specification that identifies type of the network node that generated the file. For MDT case, this attribute only has the type of "RNC" or "eNodeB".
traceCollec beginTime	This attribute specification contains a timestamp that refers to the start of the first trace data that is stored in this file. It is a complete timestamp including day, time and delta UTC hour. E.g. "2001-09-11T09:30:47-05:00".
traceRecSession	Optional element that contains the traced data associated to a Trace Recording Session. It includes: <ul style="list-style-type: none"> - the DN prefix (attribute specification "dnPrefix") - the trace session identifier (element specification "traceSessionRef") - the trace recording session identifier (attribute specification "traceRecSessionRef") - the start time of the call (attribute specification "stime") - the ue identifier (element "ue") - the traced messages (elements "msg") for trace or the UE measurements (elements "meas") for MDT
traceRecSession dnPrefix	Optional attribute specification that provides the DN prefix (see 3GPP TS 32.300 [11]).
traceSessionRef	This element provides a unique trace session identifier as described in 3GPP TS 32.421 [2]. Trace Reference is composed of MCC digits, MNC digits, and Trace ID where: <ul style="list-style-type: none"> - MCC is in BCD format, 3 digits in length (element specification "MCC")h - MNC is in BCD format, 1 to 3 digits in length, with no filler digit for MNCs less than 3 digits (element specification "MNC") - Trace ID is in hexadecimal format, 6 digits in length, hex letters (A thru F) are capitalized (element specification "TRACE_ID").
traceRecSession traceRecSessionRef	Attribute specification that provides a unique trace recording session identifier as described in 3GPP TS 32.421 [2] and 3GPP TS 32.422 [3]. Trace Recording Session Reference is represented in hexadecimal format. No filler digits for hex numbers of less than four digits. All hex letters (A thru F) are capitalized.
traceRecSession stime	Optional attribute specification that provides the start time of the call.

XML element / XML attribute specification	Description
ue	This element gives the ue identifier provided in trace activation messages. It includes: <ul style="list-style-type: none"> - the ue identifier type (attribute specification "idType") - the ue identifier value (attribute specification "idValue") This element shall not be present in the Trace record of E-UTRAN.
ue idType	Attribute specification that provides the ue identifier type (IMSI, IMEI (SV), TAC, or Public User Identity). For management based MDT, IMSI or IMEI(SV) can not be selected as ue idType.
ue idValue	Attribute specification that provides the ue identifier value, represented in decimal. This attribute is optional for management based MDT.
msg	This element contains the information associated to a traced message. This element will not be included if the file is from the MME for retrieving the IMSI/IMEI (SV) information. It includes: <ul style="list-style-type: none"> - the function name associated to the traced message (attribute specification "function") - the time difference with attribute specification "traceCollect beginTime" (attribute specification "changeTime") - a boolean value that indicates if the message is vendor specific (attribute specification "vendorSpecific") - the protocol message name (attribute specification "name") - the NE initiator of the protocol message (element "initiator") - the NE target(s) of the protocol message (element "target") - the encoded protocol message (element "rawMsg") - the traced IEs, either simple (elements "ie") or complex (elements "ieGroup"), in any order This element is trace specific and not used for MDT.
msg function	Attribute specification that provides the function name associated to the traced message (e.g. luu, lu CS, lub, Intra frequency measurement, Gb, ...). This attribute is trace specific and not used for MDT.
msg changeTime	Attribute specification that provides the time difference with attribute specification "traceCollect beginTime". It is expressed in number of seconds and milliseconds (nbsec.ms). This attribute is trace specific and not used for MDT.
msg vendorSpecific	Attribute specification whose value part is a boolean value that indicates if the message is vendor specific (true) or not (false). This attribute is trace specific and not used for MDT.
msg name	Attribute specification that provides the protocol message name. This attribute is trace specific and not used for MDT.
initiator	Optional element that identifies the NE initiator of the protocol message. Each includes: <ul style="list-style-type: none"> - the type of the network node that initiate the message (attribute specification "type") - the LDN of NE initiator of the protocol message (element's content). The element's content may be empty in case the initiator is the sender or the mobile This element is trace specific and not used for MDT.
initiator type	Optional attribute specification that provides the type of the network node that initiate the message, e.g. "RNC", "SGSN". This element is trace specific and not used for MDT.
target	Optional element that identifies the NE target(s) of the protocol message. It includes: <ul style="list-style-type: none"> - the type of the network node that receive the message (attribute specification "type") - the LDN or IP Address of NE target of the protocol message (element's content). The element's content may be empty in case the target is the sender or the mobile This element is trace specific and not used for MDT.
target type	Optional attribute specification that provides the type of the network node that receive the message, e.g. "RNC", "SGSN". This element is trace specific and not used for MDT.
NumOfTargets	Optional attribute specification that provides the number of targets that the message is sent to. This is populated ONLY if the Target is not explicitly specified and is useful when there are a large number of targets that the message is sent to. This attribute is trace specific and not used for MDT.
rawMsg	Optional element that contains the encoded protocol message. It includes: <ul style="list-style-type: none"> - the protocol name associated to the event (attribute specification "protocol") - the protocol version (attribute specification "version") - the hexadecimal encoded form of the message (element's content) This element is available only if the trace depth is maximum. This attribute is trace specific and not used for MDT.
rawMsg protocol	Attribute specification that provides the protocol name associated to the event (e.g. "Ranap"). This attribute is trace specific and not used for MDT.
rawMsg version	Attribute specification that provides the protocol version. This attribute is trace specific and not used for MDT.

XML element / XML attribute specification	Description
ieGroup	Optional element that contains a complex traced IE, i.e. an IE that contains other traced IEs. It includes: <ul style="list-style-type: none"> - the IE group name (attribute specification "name") - the IE group value (attribute specification "value") - zero or more traced IEs, either simple (elements "ie") or complex (elements "ieGroup"), in any order This element is available only if the trace depth is medium or minimum. This attribute is trace specific and not used for MDT.
ieGroup name	Optional attribute specification that provides the IE group name (e.g. "RAB parameters").
ieGroup value	Optional attribute specification that provides the IE group value when it exists (e.g. "RAB identifier"). This attribute is trace specific and not used for MDT.
ie	Optional element that contains a simple traced IE, i.e. an IE decoded from the traced message. It includes: <ul style="list-style-type: none"> - the IE name (attribute specification "name") - the IE value (element's content) This element is available only if the trace depth is medium or minimum. This attribute is trace specific and not used for MDT.
ie name	Attribute specification that provides the IE name (e.g. "Minimum DL Power"). This attribute is trace specific and not used for MDT.
meas	This element contains the information associated to a UE measurement in MDT task. It includes: <ul style="list-style-type: none"> - the measurement name (attribute specification "meas name") - the measurement value (element's content) This element is MDT specific and not used for trace.
meas name	Attribute specification that provides the IE name. This attribute is MDT specific and not used for trace.
meas changeTime	Attribute specification that provides the time difference with attribute specification "traceCollec beginTime". It is expressed in number of seconds and milliseconds (nbsec.ms). This attribute is MDT specific and not used for trace.
meas vendorSpecific	Attribute specification whose value part is a boolean value that indicates if the measurement is vendor specific (true) or not (false). The vendor specific measurements are taken at eNB or RNC. This attribute is MDT specific and not used for trace.
target cell	Attribute identifies the serving cell that the UE measurement is taken. This attribute is MDT specific and not used for trace.
UE location	Optional attribute that identifies the UE location information when the measurement is taken, can be either GNSS location information or RF fingerprints. This attribute is MDT specific and not used for trace.

A.2 XML file format definition

For encoding of the information content, XML (see Extensible Markup Language (XML) 1.0, W3C Recommendation [5]) will be used. The XML schema contains the mark-up declarations that provide a grammar for the trace file format. The XML schema is defined below.

A.2.1 XML trace/MDT file diagram

The following figure describes the XML element structure of a trace/MDT XML file.

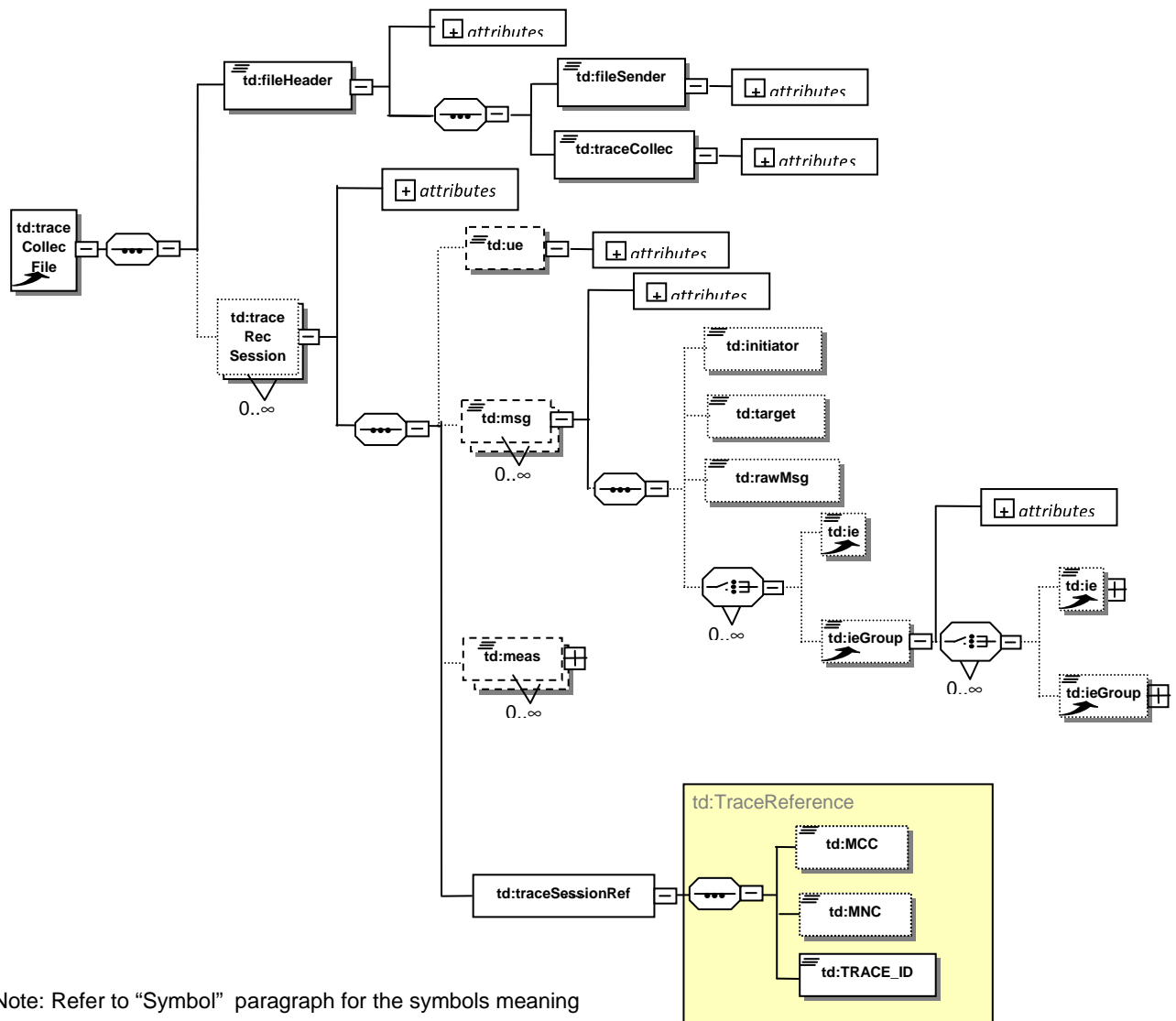

Note: Refer to “Symbol” paragraph for the symbols meaning

Figure : XML trace/MDT file diagram

NOTE: In case a trace only recording session, the elements/attributes (such as “meas”) which are specific to MDT but not used for trace should be excluded from the file; In case a MDT only recording session, the elements/attributes (such as “msg”) which are specific to trace but not used for MDT should be excluded from the file; In case of a combined trace and MDT recording session, all the elements/attributes are included in the file.

A.2.2 Trace data file XML schema

The following XML schema traceData.xsd is the schema for trace or MDT data XML files:

```
<?xml version="1.0" encoding="UTF-8"?>
<!--
 3GPP TS 32.423 Subscriber and Equipment Trace or MDT data definition and management
 Trace data file XML schema
 traceData.xsd
-->
<schema
  targetNamespace=
"http://www.3gpp.org/ftp/specs/archive/32_series/32.423#traceData"
  elementFormDefault="qualified"
  xmlns="http://www.w3.org/2001/XMLSchema"
  xmlns:td=
"http://www.3gpp.org/ftp/specs/archive/32_series/32.423#traceData"
>
<!-- XML types specific for Trace data file -->
<complexType name="TraceReference">
  <sequence>
    <element name="MCC" type="td:MCCType"/>
    <element name="MNC" type="td:MNCType"/>
    <element name="TRACE_ID" type="td:Trace_IDType"/>
  </sequence>
</complexType>
<simpleType name="MCCType">
  <restriction base="string">
    <pattern value="\d{3}"/>
  </restriction>
</simpleType>
<simpleType name="MNCType">
  <restriction base="positiveInteger">
    <maxExclusive value="1000"/>
  </restriction>
</simpleType>
<simpleType name="Trace_IDType">
  <restriction base="hexBinary">
    <length value="3"/>
  </restriction>
</simpleType>
<!-- Trace data file root XML element -->
<element name="traceCollecFile">
  <complexType>
    <sequence>
      <element name="fileHeader">
        <complexType>
          <sequence>
            <element name="fileSender">
              <complexType>
                <attribute name="elementDn" type="string" use="optional"/>
                <attribute name="elementType" type="string" use="optional"/>
              </complexType>
            </element>
            <element name="traceCollec">
              <complexType>
                <attribute name="beginTime" type="dateTime" use="required"/>
              </complexType>
            </element>
          </sequence>
          <attribute name="fileFormatVersion" type="string" use="required"/>
          <attribute name="vendorName" type="string" use="optional"/>
        </complexType>
      </element>
      <element name="traceRecSession" minOccurs="0" maxOccurs="unbounded">
        <complexType>
          <sequence>
            <element name="ue" minOccurs="0">
              <complexType>
                <attribute name="idType" type="string" use="required" />
                <attribute name="idValue" type="long" use="required"/>
              </complexType>
            </element>
            <!-- Element specific to trace data file -->
            <element name="msg" minOccurs="0" maxOccurs="unbounded">
              <complexType>
                <sequence>
```

```

        <element name="initiator" minOccurs="0">
            <complexType>
                <simpleContent>
                    <extension base="string">
                        <attribute name="type" type="NCName"
use="optional"/>
                    </extension>
                </simpleContent>
            </complexType>
        </element>
        <element name="target" minOccurs="0" maxOccurs="unbounded">
            <complexType>
                <simpleContent>
                    <extension base="string">
                        <attribute name="type" type="NCName"
use="optional"/>
                    </extension>
                </simpleContent>
            </complexType>
        </element>
        <element name="rawMsg" minOccurs="0">
            <complexType>
                <simpleContent>
                    <extension base="hexBinary">
                        <attribute name="protocol" type="string"
use="required"/>
                        <attribute name="version" type="string"
use="required"/>
                        <attribute name="NumOfTargets" type="integer"
use="optional"/>
                    </extension>
                </simpleContent>
            </complexType>
        </element>
        <choice minOccurs="0" maxOccurs="unbounded">
            <element ref="td:ie"/>
            <element ref="td:ieGroup"/>
        </choice>
    </sequence>
    <attribute name="function" type="string" use="required"/>
    <attribute name="name" type="string" use="required"/>
    <attribute name="changeTime" type="float" use="required"/>
    <attribute name="vendorSpecific" type="boolean" use="required"/>
</complexType>
</element>
<!-- Element specific to MDT data file -->
<element name="meas" minOccurs="0" maxOccurs="unbounded">
    <complexType>
        <simpleContent>
            <extension base="string">
                <attribute name="name" type="string" use="required"/>
                <attribute name="changeTime"
type="float" use="required"/>
                <attribute name="vendorSpecific" type="boolean" use="required"/>
                <attribute name="targetCell" type="string" use="required"/>
                <attribute name="ueLocation" type="string" use="required"/>
            </extension>
        </simpleContent>
    </complexType>
</element>
    <element name="traceSessionRef" type="td:TraceReference"/>
</sequence>
<attribute name="dnPrefix" type="string" use="optional"/>
<attribute name="traceRecSessionRef" type="long" use="required"/>
<attribute name="stime" type="dateTime" use="optional"/>
</complexType>
</element>
</sequence>
</complexType>
</element>
<!-- Additional supporting XML elements -->
<element name="ieGroup">
    <complexType>
        <choice minOccurs="0" maxOccurs="unbounded">
            <element ref="td:ie"/>
            <element ref="td:ieGroup"/>
        </choice>
        <attribute name="name" type="string" use="optional"/>
    </complexType>
</element>

```

```
        <attribute name="value" type="string" use="optional"/>
      </complexType>
    </element>
    <element name="ie">
      <complexType>
        <simpleContent>
          <extension base="string">
            <attribute name="name" type="string" use="required"/>
          </extension>
        </simpleContent>
      </complexType>
    </element>
  </schema>
```

Annex B (normative): Trace Report File Conventions and Transfer Procedure

This annex describes naming conventions of files containing trace results and the procedure to transfer these files from the network to the NM.

B.1 File naming convention

The following convention shall be applied for trace result file naming:

<Type><Startdate>.<Starttime>-<SenderType>.<SenderName>.[<TraceReference>].[<TraceRecordingSessionRef>]

- 1) The Type field indicates if the file contains trace data for single or multiple calls, where:
 - "A" means single Trace Recording Session, single sender NE
 - "B" means multiple Trace Recording Sessions, single sender NE
 - "C" means IMSI/IMEI (SV) information for cell traffic trace or IMEI-TAC if area based MDT trace is involved (3GPP TS 32.422 [3] clause 4.4)
- 2) The Startdate field indicates the date of the first record in the trace file. The Startdate field is of the form YYYYMMDD, where:
 - YYYY is the year in four-digit notation;
 - MM is the month in two digit notation (01 - 12);
 - DD is the day in two digit notation (01 - 31).
- 3) The Starttime field indicates the time of the first record in the trace file. The Starttime field is of the form HHMMshhmm, where:
 - HH is the two digit hour of the day (local time), based on 24 hour clock (00 - 23);
 - MM is the two digit minute of the hour (local time),
 - s is the sign of the local time differential from UTC (+ or -), in case the time differential to UTC is 0 then the sign may be arbitrarily set to "+" or "-";
 - hh is the two digit number of hours of the local time differential from UTC (00-23);
 - mm is the two digit number of minutes of the local time differential from UTC (00-59).
- 4) SenderType field is the type of NE defined by IOC attribute managedElementType in 3GPP TS 32.622 [12] that recorded and sent the trace file; SenderName field is the identifier of the NE that recorded and sent the trace file.
- 5) TraceRecordingSessionReference field is set only if the type field is A, and is represented in hexa-decimal format. TraceRecordingSessionReference is a 4 digit hexadecimal number and will not include filler digits for values less than 4 digits in length. All hexadecimal letters (A thru F) are capitalized.
- 6) TraceReference field is set if the type field is A. For type B the Trace Reference is optional and will be used when one trace file is created per trace session with multiple trace recording session. Trace Reference is represented in hexadecimal format. Trace Reference as defined in 3GPP TS 32.422 [1] is composed of PLMN ID (MCC, MNC) and Trace ID. The PLMN identity consists of 3 digits for MCC followed by either - a filler digit plus 2 digits from MNC (in case of 2 digit MNC) or 3 digits from MNC (in case of a 3 digit MNC). MCC and MNC are in BCD format.

Example: If MCC: 405, MNC: 139

octet 1: 0x04 (MCC digit 2, MCC digit 1)

octet 2: 0x15 (MNC digit 1, MCC digit 3)

octet 3: 0x93 (MNC digit 3, MNC digit 2)

Also if the MNC is 2 digits (MCC: 405 and MNC 39)

octet 1: 0x04 (MCC digit 2, MCC digit 1)

octet 2: 0xF5 (MNC digit 1, MCC digit 3)

octet 3: 0x93 (MNC digit 3, MNC digit 2)

7) Trace Reference is set if the type field is C.

See bullet 6 above for details regarding the representation of the Trace Reference. Some examples describing file naming convention:

1) file name: A20090928.2315+0200-MME.MME5. 13F23200056.125,

meaning: file produced by MME<MME5> on September 28, 2009, first trace record at 23:15 local with a time differential of +2 hours against UTC. The file contains trace data for the Trace Session with the Trace reference 13F23200056 (where MCC is 312, MNC is 23, and Trace ID is 000056, all in hexadecimal format) and for the Trace Recording Session with the reference 125.

2) file name: B20030115.1700-0300-RNC.RNC02,

meaning: file produced by RNC<RNC02> on January 15, 2003, first trace record at 17:00 local with a time differential of -3 hours against UTC. The file contains trace data for several Trace Recording Sessions.

3) file name: B20030115.1700-0300-RNC.RNC02. 4358070034D7,

meaning: file produced by RNC<RNC02> on January 15, 2003, first trace record at 17:00 local with a time differential of -3 hours against UTC. The file contains trace 4358070034D7 (where MCC is 348, MNC is 570, and Trace ID is 0034D7) data for Trace reference and several Trace Recording Sessions.

4) file name C20030115.1700-0300-MME.MME02. 26F452550021

Meaning: file produced by MME<MME02> on January 15, 2003, first trace record at 17:00 local with a time differential of -3 hours against UTC. The file contains IMSI/IMEI (SV) or IMEI-TAC information for one or more UEs traced at eNB with Trace Reference 26F452550021 (where MCC is 624, MNC is 25, and Trace ID is 550021).

B.2 File transfer

- Data retrieval and storage mechanisms are vendor specific.
- There is no constraint on data retrieval periodicity.

Annex C (informative): Trace Functional Architecture: Reporting

C.1 Figure of Trace Reporting

The following represents the trace reporting procedures.

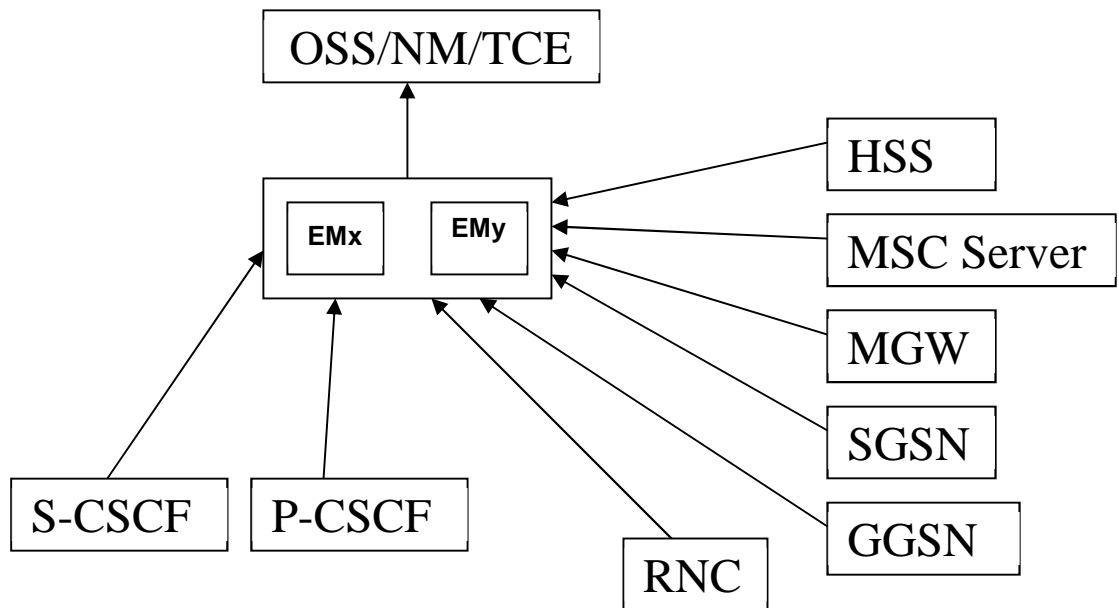

Figure C.1.1: Trace Reporting in System context A

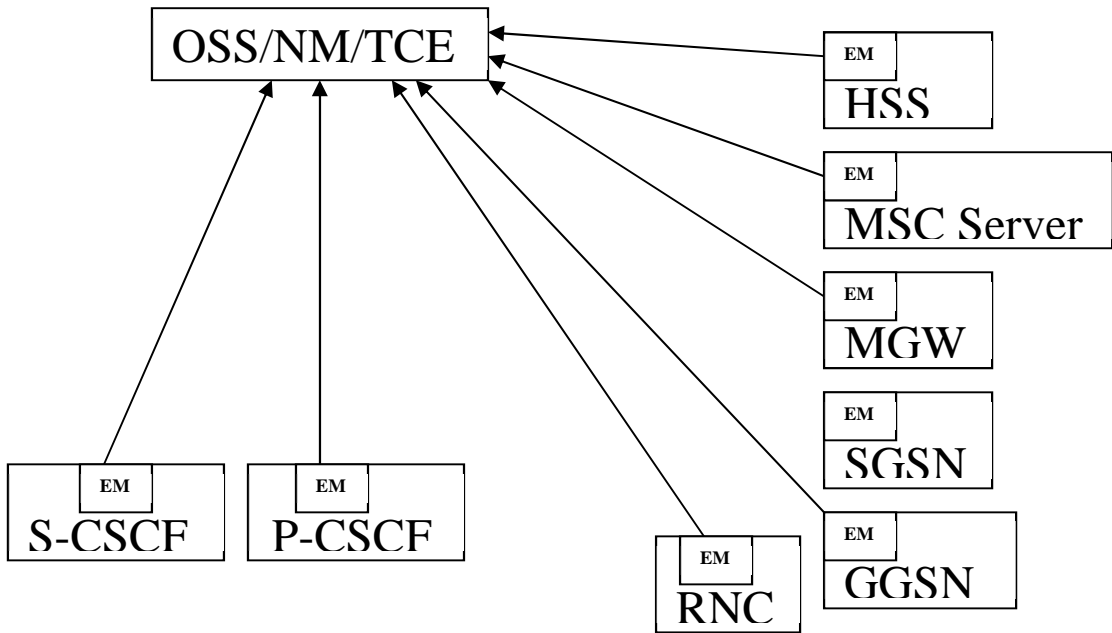

Figure C.1.2: Trace Reporting in System Context B

Annex D (informative): Examples of trace files

D.1 Examples of trace XML file

D.1.1 Example of XML trace file with the maximum level of details

```
<?xml version="1.0" encoding="UTF-8"?>
<traceCollecFile xmlns="http://www.3gpp.org/ftp/specs/archive/32_series/32.423#traceData"
xmlns:xsi="http://www.w3.org/2001/XMLSchema-instance"
xsi:schemaLocation="http://www.3gpp.org/ftp/specs/archive/32_series/32.423#traceData
http://www.3gpp.org/ftp/specs/archive/32_series/32423#traceData">
<fileHeader fileFormatVersion="32.423 V6.0" vendorName="Company NN">
  <fileSender elementDn="DC=a1.companyNN.com,SubNetwork=1, ManagedElement=RNC-1"
elementType="RNC"/>
  <traceCollec beginTime="2001-09-11T09:30:47-05:00"/>
</fileHeader>
<traceRecSession dnPrefix="DC=a1.companyNN.com,SubNetwork=1" traceRecSessionRef="1" stime="2001-
09-11T09:30:47-05:00">
  <ue idType="IMSI" idValue="32795"/>
  <msg function="Iub" name="Radio LinkSetup Request" changeTime="0.005"
vendorSpecific="false">
    <target type="Cell">SubNetwork=1,ManagedElement=Cell-1</target>
    <rawMsg protocol="Nbap" version="001">A9FD64E12C</rawMsg>
  </msg>
  <traceSessionRef>
    <MCC>460</MCC>
    <MNC>10</MNC>
    <TRACE_ID>000122</TRACE_ID>
  </traceSessionRef>
</traceRecSession>
</traceCollecFile>
```

An additional example added;

```
<?xml version="1.0" encoding="UTF-8"?>
<traceCollecFile xmlns="http://www.3gpp.org/ftp/specs/archive/32_series/32.423#traceData"
xmlns:xsi="http://www.w3.org/2001/XMLSchema-instance"
xsi:schemaLocation="http://www.3gpp.org/ftp/specs/archive/32_series/32.423#traceData
http://www.3gpp.org/ftp/specs/archive/32_series/32423#traceData">
<fileHeader fileFormatVersion="32.423 V9.0" vendorName="Company NN">
  <fileSender elementDn="DC=a1.companyNN.com,SubNetwork=1, ManagedElement=MME-1 "
elementType="MME"/>
  <traceCollec beginTime="2001-09-11T09:30:47-05:00"/>
</fileHeader>
<traceRecSession dnPrefix="DC=a1.companyNN.com,SubNetwork=1" traceRecSessionRef="2" stime="2001-
09-11T09:30:47-05:00">
  <ue idType="IMSI" idValue="32795"/>
  <msg function="S1AP" name="Handover Request" changeTime="0.005" vendorSpecific="false">
    <target type="Cell">SubNetwork=1,ManagedElement=Cell-1</target>
    <target type="Cell">SubNetwork=1,ManagedElement=Cell-2</target>
    <target type="Cell">123.222.213.5 </target>
    <rawMsg protocol="S1AP" version="001" NumOfTargets="3">A9FD64E12C</rawMsg>
  </msg>
  <traceSessionRef>
    <MCC>460</MCC>
    <MNC>10</MNC>
    <TRACE_ID>000122</TRACE_ID>
  </traceSessionRef>
</traceRecSession>
</traceCollecFile >
```

D.1.2 Example of XML trace file with the minimum level of details

```

<?xml version="1.0" encoding="UTF-8"?>
<traceCollecFile xmlns="http://www.3gpp.org/ftp/specs/archive/32_series/32.423#traceData"
xmlns:xsi="http://www.w3.org/2001/XMLSchema-instance"
xsi:schemaLocation="http://www.3gpp.org/ftp/specs/archive/32_series/32.423#traceData
http://www.3gpp.org/ftp/specs/archive/32_series/32.423#traceData">
  <fileHeader fileFormatVersion="32.423 V6.0" vendorName="Company NN">
    <fileSender elementDn="DC=al.companyNN.com,SubNetwork=1, ManagedElement=RNC-1"
elementType="RNC"/>
    <traceCollec beginTime="2001-09-11T09:30:47-05:00"/>
  </fileHeader>
  <traceRecSession dnPrefix="DC=al.companyNN.com,SubNetwork=1" traceRecSessionRef="1" stime="2001-
09-11T09:30:47-05:00">
    <ue idType="IMSI" idValue="32795"/>
    <msg function="Iub" name="Radio Link Setup Request" changeTime="0.005"
vendorSpecific="false">
      <target type="Cell">SubNetwork=1,ManagedElement=Cell-1</target>
      <ie name="UL Scrambling Code">54</ie>
      <ie name="UL SIR Target">17.3</ie>
      <ie name="Min UL Channelisation Code Length">8</ie>
      <ie name="Poncture Limit">2</ie>
      <ieGroup name="RadioLink" value="1">
        <ie name="DL Scrambling Code">1</ie>
        <ie name="DL Channelisation Code Number">15</ie>
        <ie name="Maximum DL Power">9.3</ie>
        <ie name="Minimum DL Power">-10.1</ie>
      </ieGroup>
    </msg>
    <msg function="IuPs" name="RAB Assignment Response" changeTime="0.010"
vendorSpecific="false">
      <ieGroup name="RAB" value="1">
        <ieGroup name="RAB Failed To Setup Or Modify">
          <ie name="cause">2</ie>
        </ieGroup>
      </ieGroup>
    </msg>
    <traceSessionRef>
      <MCC>460</MCC>
      <MNC>10</MNC>
      <TRACE_ID>000123</TRACE_ID>
    </traceSessionRef>
  </traceRecSession>
</traceCollecFile>

```

D.1.3 Example of XML trace file for IMSI information from the MME

```

<?xml version="1.0" encoding="UTF-8"?>
<traceCollecFile xmlns=http://www.3gpp.org/ftp/specs/archive/32_series/32.423#traceData
xmlns:xsi="http://www.w3.org/2001/XMLSchema-instance"
xsi:schemaLocation="http://www.3gpp.org/ftp/specs/archive/32_series/32.423#traceData
http://www.3gpp.org/ftp/specs/archive/32_series/32423#traceData">
<fileHeader fileFormatVersion="32.423 V8.0" vendorName="Company NN">
  <fileSender elementDn="DC=al.companyNN.com,SubNetwork=1, ManagedElement=MME"
elementType="MME"/>
  <traceCollec beginTime="2001-09-11T09:30:47-05:00"/>
</fileHeader>
<traceRecSession dnPrefix="DC=al.companyNN.com,SubNetwork=1" traceRecSessionRef="1" stime="2001-09-
11T09:30:47-05:00">
  <ue idType="IMSI" idValue="32795"/>
  <traceSessionRef>
    <MCC>460</MCC>
    <MNC>10</MNC>
    <TRACE_ID>000130</TRACE_ID>
  </traceSessionRef>
</traceRecSession>
<traceRecSession dnPrefix="DC=al.companyNN.com,SubNetwork=1" traceRecSessionRef="2" stime="2001-09-
11T09:30:47-05:00">
  <ue idType="IMSI" idValue="12345"/>
  <traceSessionRef>
    <MCC>460</MCC>
    <MNC>10</MNC>
    <TRACE_ID>000130</TRACE_ID>
  </traceSessionRef>
</traceRecSession>
</traceCollecFile>

```

D.1.4 Example of MDT XML file

```
<?xml version="1.0" encoding="UTF-8"?>
<traceCollecFile xmlns="http://www.3gpp.org/ftp/specs/archive/32_series/32.423#traceData"
xmlns:xsi="http://www.w3.org/2001/XMLSchema-instance"
xsi:schemaLocation="http://www.3gpp.org/ftp/specs/archive/32_series/32.423#traceData
http://www.3gpp.org/ftp/specs/archive/32_series/32.423#traceData">
  <fileHeader fileFormatVersion="32.423 V6.0" vendorName="Company NN">
    <fileSender elementDn="DC=a1.companyNN.com,SubNetwork=1, ManagedElement=RNC-1"
elementType="RNC" />
    <traceCollec beginTime="2001-09-11T09:30:47-05:00" />
  </fileHeader>
  <traceRecSession dnPrefix="DC=a1.companyNN.com,SubNetwork=1" traceRecSessionRef="1",
stime="2001-09-11T09:30:47-05:00">
    <ue idType="IMSI" idValue="32795" />
    <meas name="RSRP" changeTime="0.005" vendorSpecific="false" targetCell="Cell-1"> 97 </meas>
    <meas name="RSRQ" changeTime="0.010" vendorSpecific="false" targetCell="Cell-2"> 34 </meas>
    <meas name="Power Headroom" changeTime="0.015" vendorSpecific="false" targetCell="Cell-1"> 5
  </meas>
  <traceSessionRef>
    <MCC>460</MCC>
    <MNC>10</MNC>
    <TRACE_ID>000150</TRACE_ID>
  </traceSessionRef>
</traceRecSession>
</traceCollecFile>
```

Annex E (informative):
Void

Annex F (informative): Change history

Change history								
Date	TSG #	TSG Doc.	CR	Rev	Subject/Comment	Cat	Old	New
Sep 2005	SA_29	SP-050623	0004	1	Clarify Trace Messages for FDD and TDD modes	B	6.2.0	7.0.0
Dec 2005	SA_30	SP-050690	0007	--	Differentiate Trace Contents for FDD and TDD	B	7.0.0	7.1.0
Dec 2005	SA_30	SP-050709	0008	--	Remove SFN-SFN observed time difference - Align with 25.331	A	7.0.0	7.1.0
Dec 2005	SA_30	SP-050709	0009	--	Correction to name space URI	A	7.0.0	7.1.0
Jun 2006	SA_32	SP-060258	0011	--	Correction for compilation errors of schema and addition of the missing link	A	7.1.0	7.2.0
Sep 2006	SA_33	SP-060533	0013	--	Correct UTRA Carrier RSSI for trace contents- Align with RAN2's 25.331	A	7.2.0	7.3.0
Sep 2006	SA_33	SP-060533	0015	--	Correct CFN-SFN observed time difference for trace IE - Align with RAN2's 25.331	A	7.2.0	7.3.0
Sep 2006	SA_33	SP-060552	0016	--	Add Trace IEs to differentiate UARFCN for FDD and TDD - Align with RAN2's 25.331	C	7.2.0	7.3.0
Sep 2006	SA_33	SP-060552	0018	--	Correction in XML schema and examples	F	7.2.0	7.3.0
Dec 2006	SA_34	SP-060728	0019	--	Correct the errors in figure and examples	F	7.3.0	7.4.0
Mar 2009	SA_43	SP-090207	0020	--	Constraint of the presence for the "ue" element	F	7.4.0	8.0.0
Mar 2009	SA_43	SP-090207	0021	--	Adding PGW trace record content	B	7.4.0	8.0.0
Mar 2009	SA_43	SP-090207	0022	--	Alignment with 32.421 and 32.422. Introduction medium and minimum trace dept IEs for the GTP and S1AP protocols in MME	B	7.4.0	8.0.0
Mar 2009	SA_43	SP-090207	0023	--	Alignment with 32.421 and 32.422. Introduction of E-UTRAN	B	7.4.0	8.0.0
Jun 2009	SA_44	SP-090289	0024	--	Alignment with 32.421 and 32.422 - Introduction medium and minimum trace depth IEs in MME.	F	8.0.0	8.1.0
Jun 2009	SA_44	SP-090289	0025	--	Add missing SGW Trace Record content	F	8.0.0	8.1.0
Jun 2009	SA_44	SP-090289	0026	--	Add missing PGW Trace Record content for Gx and S6b interfaces	F	8.0.0	8.1.0
Jun 2009	SA_44	SP-090289	0027	--	Alignment with 32.421 and 32.422 - Introduction medium and minimum trace dept IEs for NAS in MME.	F	8.0.0	8.1.0
Sep 2009	SA_45	SP-090534	0028	--	Correction in TS 32.423 Trace Depth requirements for MME, SGW and PGW	F	8.1.0	8.2.0
Sep 2009	SA_45	SP-090534	0030	--	Unable to uniquely identify file name when one file per UE trace	F	8.1.0	8.2.0
Sep 2009	SA_45	SP-090534	0031	--	Added a file format and example for sending the IMSI/IMEI (SV) information from the MME	F	8.1.0	8.2.0
Sep 2009	SA-45	SP-090542	0029	--	Correction on XML file format for Trace failure notification	F	8.2.0	9.0.0
Dec 2009	SA-46	SP-090719	0032	--	Clarify Trace Reference and Trace Recording Session Reference format	F	9.0.0	9.1.0
Jan 2010	--	--	--	--	Removal of track changes	--	9.1.0	9.1.1
Mar 2010	SA-47	SP-100034	0034	--	Align with 32.421 and 33.401	A	9.1.1	9.2.0
Sep 2010	SA-49	SP-100487	0039	--	Correcting references	A	9.2.0	9.3.0
Sep 2010	SA-49	SP-100489	0036	--	Add Diameter in HSS Trace Record Content	B	9.2.0	9.3.0
Sep 2010	SA-49	SP-100488	0035	--	Correct call trace file format to allow multiple targets	F	9.3.0	10.0.0
Dec 2010	SA-50	SP-100833	0040	1	Add trace Record Content in MME trace and SGSN trace - Align with 32.421 and 32.422	C	10.0.0	10.1.0
Dec 2010	SA-50	SP-100858	0042	--	Correcting the Trace Reference definition - Align with RAN3 TS 36.423, 36.413	A	10.0.0	10.1.0
Dec 2010	SA-50	SP-100833	0043	--	Adding the S6a trace interface for HSS	B	10.0.0	10.1.0
Dec 2010	SA-50	SP-100833	0044	--	Correcting the Identification of IMS Subscriber Tracing - Align with 32.421	F	10.0.0	10.1.0
Dec 2010	SA-50	SP-100831	0047	--	Add missing interfaces S3, S4 and S6d trace record contents of SGSN - Align with 32.422	A	10.0.0	10.1.0
Mar 2011	SA-51	SP-110095	0049	-	Addition of trace Record Content of EIR Trace	B	10.1.0	10.2.0
May 2011	SA-52	SP-110292	0050	1	Applying trace data file to MDT data format	B	10.2.0	10.3.0
Dec 2011	SA-54	SP-110715	0054	--	Correcting the description of meas vendorSpecific attribute in the XML trace file	F	10.3.0	10.4.0
March 2012	SA-55	SP-120044	0060	--	Modify E-UTRAN Trace Record Content	A	10.4.0	10.5.0
March 2012	SA-55	SP-120053	0057	1	Correct IMSI retrieval file to include MDT anonymization info	F	10.4.0	10.5.0
June 2013	SA-60	SP-130265	0071	1	Correct trace file name format	A	10.5.0	10.6.0
Sept-2013	SA-61	SP-130432	0074	2	Correction on some inconsistent definitons for trace data file parameters	F	10.6.0	10.7.0
March-2014	SA-63				This version is identical to the previous version due to no implementation error.		10.7.0	10.8.0
April-2014					Correction in history table		10.8.0	10.8.1
Jun-2014	SA-64	SP-140330	0078	2	Corrections of Trace Session identifier	A	10.8.1	10.9.0

Change history							
Date	Meeting	TDoc	CR	Rev	Cat	Subject/Comment	New version
2020-07	SA#88e	SP-200488	0106	-	A	clean up of the editor notes	10.10.0

History

Document history		
V10.2.0	April 2011	Publication
V10.3.0	June 2011	Publication
V10.4.0	January 2012	Publication
V10.5.0	March 2012	Publication
V10.6.0	July 2013	Publication
V10.7.0	October 2013	Publication
V10.8.1	April 2014	Publication
V10.9.0	July 2014	Publication
V10.10.0	August 2020	Publication