



**Digital cellular telecommunications system (Phase 2+) (GSM);  
Universal Mobile Telecommunications System (UMTS);  
LTE;  
Telecommunication management;  
Trace Management Integration Reference Point (IRP);  
Information Service (IS)  
(3GPP TS 32.442 version 16.0.0 Release 16)**



---

Reference

RTS/TSGS-0532442vg00

---

Keywords

GSM,LTE,UMTS

**ETSI**

650 Route des Lucioles  
F-06921 Sophia Antipolis Cedex - FRANCE

Tel.: +33 4 92 94 42 00 Fax: +33 4 93 65 47 16

Siret N° 348 623 562 00017 - NAF 742 C  
Association à but non lucratif enregistrée à la  
Sous-Préfecture de Grasse (06) N° 7803/88

---

**Important notice**

The present document can be downloaded from:

<http://www.etsi.org/standards-search>

The present document may be made available in electronic versions and/or in print. The content of any electronic and/or print versions of the present document shall not be modified without the prior written authorization of ETSI. In case of any existing or perceived difference in contents between such versions and/or in print, the prevailing version of an ETSI deliverable is the one made publicly available in PDF format at [www.etsi.org/deliver](http://www.etsi.org/deliver).

Users of the present document should be aware that the document may be subject to revision or change of status.

Information on the current status of this and other ETSI documents is available at

<https://portal.etsi.org/TB/ETSIDeliverableStatus.aspx>

If you find errors in the present document, please send your comment to one of the following services:

<https://portal.etsi.org/People/CommitteeSupportStaff.aspx>

---

**Copyright Notification**

No part may be reproduced or utilized in any form or by any means, electronic or mechanical, including photocopying and microfilm except as authorized by written permission of ETSI.

The content of the PDF version shall not be modified without the written authorization of ETSI.

The copyright and the foregoing restriction extend to reproduction in all media.

© ETSI 2020.

All rights reserved.

**DECT™**, **PLUGTESTS™**, **UMTS™** and the ETSI logo are trademarks of ETSI registered for the benefit of its Members.

**3GPP™** and **LTE™** are trademarks of ETSI registered for the benefit of its Members and of the 3GPP Organizational Partners.

**oneM2M™** logo is a trademark of ETSI registered for the benefit of its Members and of the oneM2M Partners.

**GSM®** and the GSM logo are trademarks registered and owned by the GSM Association.

---

## Intellectual Property Rights

### Essential patents

IPRs essential or potentially essential to normative deliverables may have been declared to ETSI. The information pertaining to these essential IPRs, if any, is publicly available for **ETSI members and non-members**, and can be found in ETSI SR 000 314: "*Intellectual Property Rights (IPRs); Essential, or potentially Essential, IPRs notified to ETSI in respect of ETSI standards*", which is available from the ETSI Secretariat. Latest updates are available on the ETSI Web server (<https://ipr.etsi.org/>).

Pursuant to the ETSI IPR Policy, no investigation, including IPR searches, has been carried out by ETSI. No guarantee can be given as to the existence of other IPRs not referenced in ETSI SR 000 314 (or the updates on the ETSI Web server) which are, or may be, or may become, essential to the present document.

### Trademarks

The present document may include trademarks and/or tradenames which are asserted and/or registered by their owners. ETSI claims no ownership of these except for any which are indicated as being the property of ETSI, and conveys no right to use or reproduce any trademark and/or tradename. Mention of those trademarks in the present document does not constitute an endorsement by ETSI of products, services or organizations associated with those trademarks.

---

## Legal Notice

This Technical Specification (TS) has been produced by ETSI 3rd Generation Partnership Project (3GPP).

The present document may refer to technical specifications or reports using their 3GPP identities. These shall be interpreted as being references to the corresponding ETSI deliverables.

The cross reference between 3GPP and ETSI identities can be found under <http://webapp.etsi.org/key/queryform.asp>.

---

## Modal verbs terminology

In the present document "**shall**", "**shall not**", "**should**", "**should not**", "**may**", "**need not**", "**will**", "**will not**", "**can**" and "**cannot**" are to be interpreted as described in clause 3.2 of the [ETSI Drafting Rules](#) (Verbal forms for the expression of provisions).

"**must**" and "**must not**" are **NOT** allowed in ETSI deliverables except when used in direct citation.

# Contents

Intellectual Property Rights .....	2
Legal Notice .....	2
Modal verbs terminology.....	2
Foreword.....	5
Introduction .....	5
1 Scope .....	6
2 References .....	6
3 Definitions and abbreviations.....	7
3.1 Definitions .....	7
3.2 Abbreviations .....	7
4 System Overview .....	7
4.1 System context .....	7
4.2 Compliance rules.....	8
5 Information Object Classes .....	8
5.1 Imported information entities and local labels .....	8
5.2 Class diagram .....	8
5.2.1 Attributes and relationships .....	8
5.2.2 Inheritance .....	10
5.3 Information object class definitions .....	10
5.3.1 TraceJob .....	10
5.3.1.1 Definition .....	10
5.3.1.2 Attributes.....	12
5.3.1.3 Attribute constraints .....	12
5.3.2 TraceRecord.....	14
5.3.2.1 Definition.....	14
5.3.2.2 Attributes.....	14
5.3.3 TraceIRP .....	14
5.3.3.1 Definition .....	14
5.3.4 ManagedEntity .....	14
5.3.4.1 Definition .....	14
5.4 Information relationship definitions .....	15
5.4.1 relation-traceIRP-traceJob (M).....	15
5.4.1.1 Definition .....	15
5.4.1.2 Roles .....	15
5.4.2 relation-traceJob-managedEntity (M).....	15
5.4.2.1 Definition .....	15
5.4.2.2 Roles .....	15
5.4.3 relation-traceJob-traceRecord (M).....	15
5.4.3.1 Definition .....	15
5.4.3.2 Roles .....	15
5.5 Information attribute definitions.....	16
5.5.1 Definition and legal values .....	16
6 Interface Definition .....	20
6.1 Class diagram representing interfaces .....	20
6.2 Generic rules .....	20
6.3 TraceIRPManagement (M).....	21
6.3.1 Operation activateTraceJob (M).....	21
6.3.1.1 Definition .....	21
6.3.1.2 Input parameters.....	22
6.3.1.3 Output parameters .....	25
6.3.1.4 Pre-condition.....	25

6.3.1.5	Post-condition .....	26
6.3.1.6	Exceptions .....	26
6.3.1.7	Constraints .....	26
6.3.2	Operation deactivateTraceJob (M) .....	27
6.3.2.1	Definition .....	27
6.3.2.2	Input parameters .....	27
6.3.2.3	Output parameters .....	27
6.3.2.4	Pre-condition .....	27
6.3.2.4	Post-condition .....	27
6.3.2.6	Exceptions .....	28
6.3.3	Operation listTraceJob (M) .....	28
6.3.3.1	Definition .....	28
6.3.3.2	Input parameters .....	28
6.3.3.3	Output parameters .....	29
6.3.3.4	Pre-condition .....	30
6.3.3.5	Post-condition .....	30
6.3.3.6	Exceptions .....	30
6.3.3.7	Constraints .....	30
6.3.4	Operation listActivatedTraceJobs (M) .....	31
6.3.4.1	Definition .....	31
6.3.4.2	Input parameters .....	31
6.3.4.3	Output parameters .....	31
6.3.5	Notification notifyTraceRecordingSessionFailure (O) .....	31
6.3.5.1	Definition .....	31
6.3.5.2	Input parameters .....	31
6.3.5.3	Triggering event .....	31
6.3.5.3.1	From state .....	31
6.3.5.3.2	To state .....	32
6.3.6	Notification notifyTraceSessionLocalActivation (M) .....	32
6.3.6.1	Definition .....	32
6.3.6.2	Input parameters .....	32
6.3.6.3	Triggering event .....	32
6.3.6.3.1	From state .....	32
6.3.6.3.2	To state .....	32
6.3.7	Notification notifyTraceSessionIdentities (CM) .....	33
6.3.7.1	Definition .....	33
6.3.7.2	Input parameters .....	33
6.3.7.3	Triggering event .....	33
6.3.7.3.1	From state .....	33
6.3.7.3.2	To state .....	33
6.3.7.4	Constraint .....	33
<b>Annex A (informative):</b>	<b>Change history .....</b>	<b>34</b>
History .....		35

---

# Foreword

This Technical Specification has been produced by the 3<sup>rd</sup> Generation Partnership Project (3GPP).

The contents of the present document are subject to continuing work within the TSG and may change following formal TSG approval. Should the TSG modify the contents of the present document, it will be re-released by the TSG with an identifying change of release date and an increase in version number as follows:

Version x.y.z

where:

- x the first digit:
  - 1 presented to TSG for information;
  - 2 presented to TSG for approval;
  - 3 or greater indicates TSG approved document under change control.
- y the second digit is incremented for all changes of substance, i.e. technical enhancements, corrections, updates, etc.
- z the third digit is incremented when editorial only changes have been incorporated in the document.

---

# Introduction

The present document is part of a TS-family covering the 3<sup>rd</sup> Generation Partnership Project; Technical Specification Group Services and System Aspects; Telecommunication management; as identified below:

32.441 "Trace Management Integration Reference Point (IRP): Requirements".

**32.442 "Trace Management Integration Reference Point (IRP): Information Service (IS)".**

32.443 "Trace Management Integration Reference Point (IRP): Common Object Request Broker Architecture (CORBA) Solution Set (SS)".

32.445 "Trace Management Integration Reference Point (IRP): eXtensible Markup Language (XML) file format definition".

The present document is part of a TS-family which describes the information service necessary for the Telecommunication Management (TM) of 3G systems. The TM principles and TM architecture are specified in 3GPP TS 32.101 [1] and 3GPP TS 32.102 [2].

Trace provides very detailed information on call level for a specific subscriber or MS. This data is an additional information source to Performance Measurements and allows deeper investigations in problems solving or in case of optimization.

---

# 1 Scope

The present document describes the mechanism used for control and configuration of the Trace, Minimization of Drive Test (MDT) and Radio Link Failure (RLF) reporting functionality through Itf-N. This specification is applicable to UMTS networks and EPS networks. GSM Trace is outside of the scope of this specification.

The conditions for supporting Network Sharing are stated in 3GPP TS 32.441 [13].

---

# 2 References

The following documents contain provisions which, through reference in this text, constitute provisions of the present document.

- References are either specific (identified by date of publication, edition number, version number, etc.) or non-specific.
- For a specific reference, subsequent revisions do not apply.
- For a non-specific reference, the latest version applies. In the case of a reference to a 3GPP document (including a GSM document), a non-specific reference implicitly refers to the latest version of that document *in the same Release as the present document*.

- [1] 3GPP TS 32.101: "Telecommunication management; Principles and high level requirements".
- [2] 3GPP TS 32.102: "Telecommunication management; Architecture".
- [3] 3GPP TS 32.150: "Telecommunication management; Integration Reference Point (IRP) Concept and definitions".
- [4] Void.
- [5] 3GPP TS 32.622: "Telecommunication management; Configuration Management (CM); Generic network resources Integration Reference Point (IRP); Network Resource Model (NRM)".
- [6] 3GPP TS 32.302: "Telecommunication management; Configuration Management (CM); Notification Integration Reference Point (IRP): Information Service (IS)".
- [7] 3GPP TS 32.342: " Telecommunication management; File Transfer (FT) Integration Reference Point (IRP): Information Service (IS)".
- [8] 3GPP TS 32.312: "Telecommunication management; Generic Integration Reference Point (IRP) management: Information Service (IS)".
- [9] 3GPP TS 32.422: "Telecommunication management; Subscriber and equipment trace; Trace control and configuration management".
- [10] 3GPP TS 32.602: "Telecommunication management; Configuration Management (CM); Basic CM Integration Reference Point (IRP): Information Service (IS)".
- [11] 3GPP TS 25.331: "Radio Resource Control (RRC); Protocol specification"
- [12] 3GPP TS 36.331: "Evolved Universal Terrestrial Radio Access (E-UTRA); Radio Resource Control (RRC); Protocol specification".
- [13] 3GPP TS 32.441: "Trace Management Integration Reference Point (IRP): Requirements".
- [14] 3GPP TS 36.300: "Evolved Universal Terrestrial Radio Access (E-UTRA) and Evolved Universal Terrestrial Radio Access Network (E-UTRAN); Overall description; Stage 2".

## 3 Definitions and abbreviations

### 3.1 Definitions

For the purposes of the present document, the terms and definitions given in 3GPP TS 32.101 [1], 3GPP TS 32.102 [2], 3GPP TS 32.150 [3] and the following apply:

**IRPAgent:** See 3GPP TS 32.102 [2].

**IRPManager:** See 3GPP TS 32.102 [2].

**MBSFN Area:** See 3GPP TS 36.300 [14]

**MBSFN Area Reserved Cell:** See 3GPP TS 36.300 [14]

### 3.2 Abbreviations

For the purposes of the present document, the abbreviations given in 3GPP TS 32.101 [1], 3GPP TS 32.102 [2], 3GPP TS 32.150 [3] and the following apply:

IOC	Information Object Class
IRP	Integration Reference Point
IS	Information Service
MBMS	Multimedia Broadcast Multicast Services
MBSFN	MBMS over a Single Frequency Network
MDT	Minimization of Drive Tests
OMG	Object Management Group
RCEF	RRC Connection Establishment Failure
RLF	Radio Link Failure
UML	Unified Modelling Language (OMG)

## 4 System Overview

### 4.1 System context

The general definition of the System Context for the present IRP is found in 3GPP TS 32.150 [3] subclause 4.7.

In addition, the set of related IRP(s) relevant to the present IRP is shown in the two diagrams below.

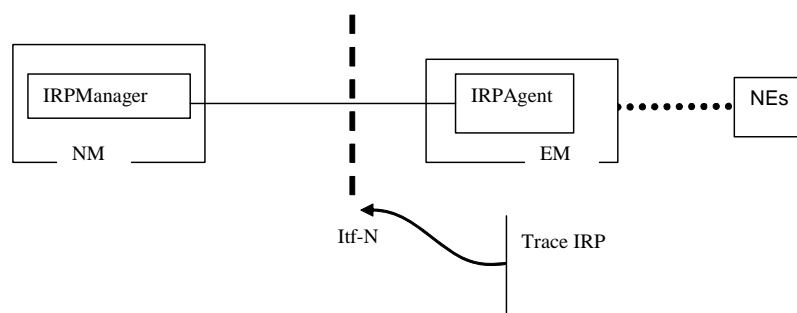

**Figure 4.1.1: System Context A**



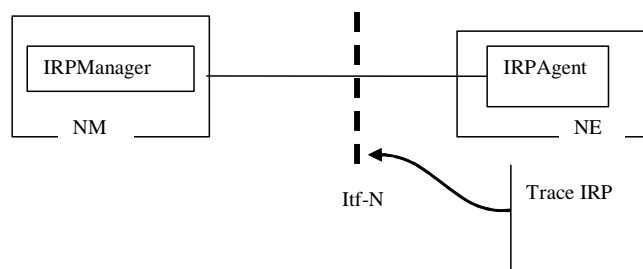

Figure 4.1.2: System Context B

## 4.2 Compliance rules

For general definitions of compliance rules related to qualifiers (Mandatory/Optional/Conditional) for *operations*, *notifications* and *parameters* (of operations and notifications) please refer to 3GPP TS 32.150 [3].

# 5 Information Object Classes

## 5.1 Imported information entities and local labels

Label reference	Local label
3GPP TS 32.622 [5], information object class, Top	Top
3GPP TS 32.622 [5], information object class, IRPAgent	IRPAgent
3GPP TS 32.622 [5], information object class, GenericIRP	GenericIRP
3GPP TS 32.302 [6], information object class, NotificationIRP	NotificationIRP
3GPP TS 32.342 [7], information object class, FileTransferIRP	FileTransferIRP
3GPP TS 32.602 [10], information object class, ManagedEntity	ManagedEntity

## 5.2 Class diagram

### 5.2.1 Attributes and relationships

This clause introduces the set of Information Object Classes (IOCs) that encapsulate information within the IRPAgent. The intent is to identify the information required for the TraceIRP implementation of its operations and notification emission. This clause provides the overview of all support object classes in UML. Subsequent clauses provide more detailed specification of various aspects of these support object classes.

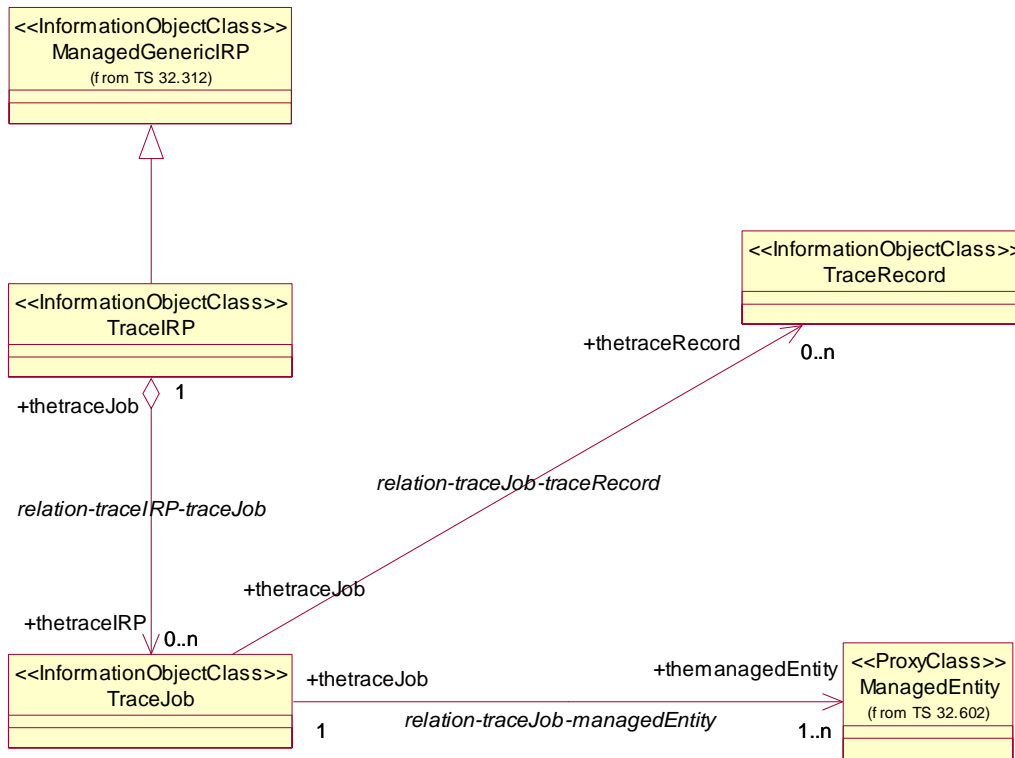

Figure 5.2.1: Information Object Class (IOC) UML diagram

## 5.2.2 Inheritance

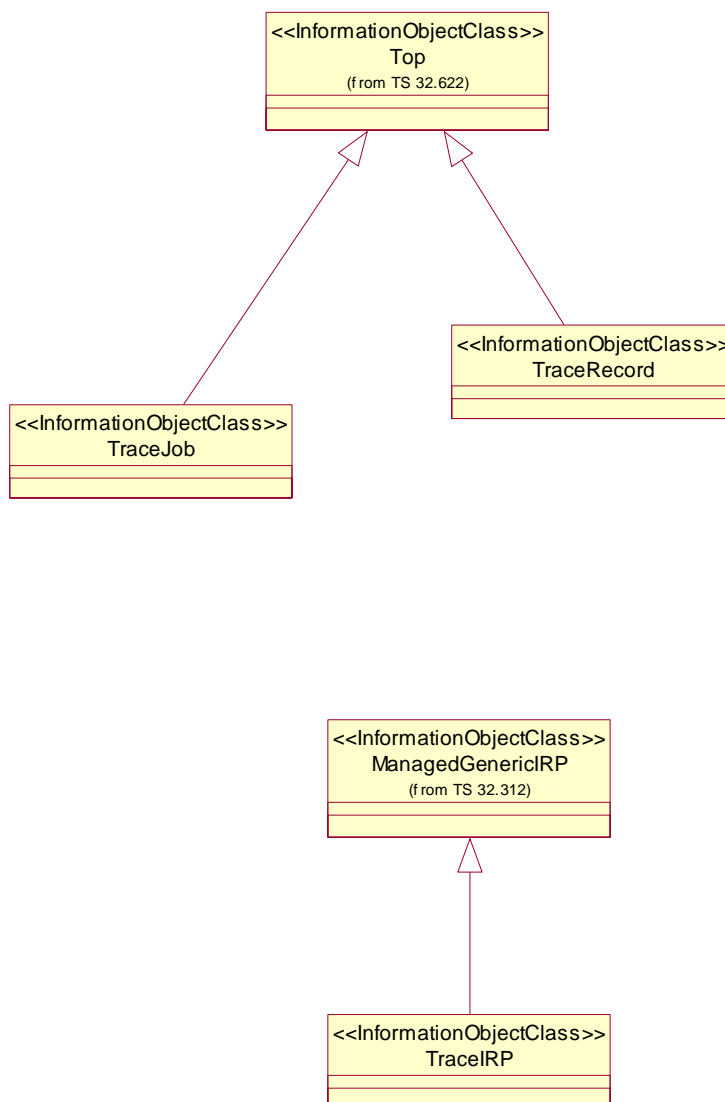

Figure 5.2.2: Information Object Class Inheritance UML Diagram

## 5.3 Information object class definitions

### 5.3.1 TraceJob

#### 5.3.1.1 Definition

It represents a task that controls the Trace Sessions and collects the trace data (i.e. collects the `TraceRecord` of multiple `ManagedEntity` instances). The `TraceReference` is a unique ID, which identifies the Trace Session that has been created by the `TraceJob` and activated to one or multiple `ManagedEntity` instance(s).

It represents also the task that controls the UE based network performance measurements.

When a `TraceJob` is created the following attributes cannot be modified via the Itf-N:

- TraceReference
- ListOfInterfaces
- ListofNeTypes
- TraceDepth
- TraceTarget
- TriggeringEvent
- JobType
- areaScope
- ListOfMeasurements
- ReportingTrigger
- ReportInterval
- ReportAmount
- EventThreshold
- LoggingInterval
- LoggingDuration
- IPAddressOfTCE
- AnonymizationofMMDTData
- MeasurementPeriodLTE
- MeasurementPeriodUMTS
- CollectionPeriodRrmUmts
- CollectionPeriodRrmLte
- PositioningMethod
- MeasurementQuantity
- PLMNTarget
- MBSFNAreaList

If for any reason the TraceIRP determines that a Trace Session has been activated in its ManagedEntity(ies) the TraceIRP shall emit the "noitfyTraceSessionLocalActivation" notification to the subscribed IRPManagers to inform the active Trace Sessions. The IRPManagers can decide whether they deactivate the Trace Session or keep the Trace Session active. (E.g. if the TraceReference is colliding with an existing TraceJob's TraceReference, the IRPManager may decide to immediately deactivate the Trace Session in that ManagedEntity.)

The TraceJob shall use its information to activate and configure Trace Session(s) in the requested ManagedEntity instance(s). When the TraceIRP determines that there are available TraceRecord files, it shall emit a notification to all subscribed IRPManagers informing the availability of the files. The method and the notification of the available files is described in the File Transfer IRP (3GPP TS 32.342 [7]).

If a TraceJob receives an indication from one of its ManagedEntity that starting a Trace Recording Session is failed for any reason, the "notifyTraceRecordingSessionFailure" notification may be emitted to inform all subscribed IRPManagers that there was a Trace Recording Session that was not started in the ManagedEntity.

### 5.3.1.2 Attributes

Attribute name	Support Qualifier
traceReference	M
listOfInterfaces	O
listOfNeTypes	CM
traceDepth	CM
traceTarget	M
triggeringEvent	CM
traceCollectionEntityAddress	M
jobType	M
listOfMeasurements	CM
reportingTrigger	CM
reportInterval	CM
reportAmount	CM
eventThreshold	CM
loggingInterval	CM
loggingDuration	CM
areaScope	CM
anonymizationOfMDTData	CM
measurementPeriodLTE	CM
measurementPeriodUMTS	CM
collectionPeriodRrmUmts	CM
collectionPeriodRrmLte	CM
positioningMethod	CM
measurementQuantity	CM
pLMNTarget	CM
mBSFNAreaList	CM

### 5.3.1.3 Attribute constraints

The `listOfNeTypes` attributes shall be present only for Signalling Based Activation.

The `traceTarget` shall be public ID in case of a Management Based Activation is done to an `ScscfFunction`.

The `TraceTarget` shall be `cell` only in case of the UTRAN cell traffic trace function.

The `TraceTarget` shall be `E-UtranCell` only in case of E-UTRAN cell traffic trace function. The `traceTarget` shall be either IMSI or IMEI(SV) if the Trace Session is activated to any of the following `ManagedEntity(ies)`:

- `HssFunction`
- `MscServerFunction`
- `SgsnFunction`
- `GgsnFunction`
- `BmscFunction`
- `RncFunction`
- `MmeFunction`

The `traceTarget` shall be IMSI if the Trace Session is activated to a `ManagedEntity` playing a role of `ServingGWFunction`.

In case of subscription based MDT, the `traceTarget` attribute shall be able to carry (IMSI or IMEI(SV)), the `areaScope` attribute shall be able to carry a list of (`cell` or `EUtranCell` or `TA/LA/RA`).

In case of area based Immediate MDT, the `traceTarget` attribute shall be null value, the `areaScope` attribute shall carry a list of (`Utrancell` or `E-UtranCell`).

In case of area based Logged MDT, the `traceTarget` attribute shall carry an eNodeBs or a RNC. The Logged MDT should be initiated on the specified eNodeB/RNC in `TraceTarget`. The `areaScope` attribute shall carry a list of (Utrancell or E-UtranCell or TA/LA/RA)..

In case of RLF reporting, or RCEF reporting, the `traceTarget` attribute shall be null value, the `areaScope` attribute shall carry one or list of eNBs.

- `traceTarget`: This attribute shall be present if Trace or MDT RLF or RCEF reporting is supported.
- `areaScope`: This attribute shall be present if MDT is supported.
- `triggeringEvent`: This attribute shall be present only if Trace is supported.
- `listOfMeasurements`: This attribute shall be present only if MDT is supported and the `JobType` attribute is set to `ImmediateMDT`.
- `reportingTrigger`: This attribute shall be present only if MDT is supported and the `JobType` attribute is set to `ImmediateMDT` and the `ListOfMeasurements` attribute is configured for M1 (for both UMTS and LTE) or M2 (only for UMTS).
- `reportInterval`: This attribute shall be present only if MDT is supported and the `JobType` attribute is set to `ImmediateMDT` and the `ReportingTrigger` is configured for `PeriodicMeasurements`
- `reportAmount`: This attribute shall be present only if MDT is supported and the `JobType` attribute is set to `ImmediateMDT` and the `ReportingTrigger` attribute is configured for `PeriodicMeasurements`.
- `eventThreshold`: This attribute shall be present only if MDT is supported and the `JobType` attribute is set to `ImmediateMDT` and the `ReportTrigger` attribute is configured for `A2EventReporting` in LTE or `1F/1IEventReporting` in UMTS.
- `loggingInterval`: This attribute shall be present only if MDT is supported and the `JobType` attribute is set to `LoggedMDT` or `Logged MBSFN MDT`.
- `loggingDuration`: This attribute shall be present only if MDT is supported and the `JobType` attribute is set to `LoggedMDT` or `Logged MBSFN MDT`.
- `anonymizationOfMDTData`: This attribute shall be present only if MDT is supported and the `mdtAreaScope` attribute is present.
- `measurementPeriodLTE`: This attribute shall be present only if MDT is supported and the `JobType` attribute is set to `Immediate MDT` or `combine Trace and Immediate MDT` and the `listOfMeasurements` parameter for LTE has either M4 or M5 measurement set.
- `measurementPeriodUMTS`: This attribute shall be present only if MDT is supported and the `JobType` attribute is set to `Immediate MDT` or `combine Trace and Immediate MDT` and the `listOfMeasurements` parameter for UMTS has M6 or M7 measurements set.
- `collectionPeriodRrmUmts`: This attribute shall be present only if MDT is supported and the `JobType` attribute is set to `Immediate MDT` or `combine Trace and Immediate MDT` and the `listOfMeasurements` parameter has any of M3, M4, M5 measurement set in case of UMTS.
- `collectionPeriodRrmLte`: This attribute shall be present only if MDT is supported and the `JobType` attribute is set to `Immediate MDT` or `combine Trace and Immediate MDT` and the `listOfMeasurements` parameter has any of M2, M3 measurement set in case of LTE.
- `positioningMethod`: This attribute shall be present only if MDT is supported and the `JobType` attribute is set to `Immediate MDT` or `combine Trace and Immediate MDT`.
- `measurementQuantity`: This attribute shall be present only if MDT is supported and the `JobType` attribute is set to `Immediate MDT` or `combined Trace and Immediate MDT` and the `reportingTrigger` parameter is set to `event 1F`.

- `plMNTarget`: This attribute shall be present for management based activation when several PLMNs are supported in the RAN.
- `mBSFNAreaList`: This attribute shall be present only if Logged MBSFN MDT is supported and the `JobType` attribute is set to `Logged MBSFN MDT`. This is applicable only for eUTRAN.

## 5.3.2 TraceRecord

### 5.3.2.1 Definition

`TraceRecord` is the representation of the files containing the logged information from the Trace Recording Sessions.

### 5.3.2.2 Attributes

Attribute name	Visibility	Support Qualifier	Read Qualifier	Write Qualifier
<code>fileName</code>	+	M	M	-

## 5.3.3 TraceIRP

### 5.3.3.1 Definition

`TraceIRP` is the representation of the trace management capabilities specified by the present document. This IOC inherits from `ManagedGenericIRP` IOC specified in 3GPP TS 32.312 [8].

## 5.3.4 ManagedEntity

### 5.3.4.1 Definition

In case of Signalling Based Activation the `ManagedEntity` represents the role that can be played by an instance of one of the following IOCs:

- `HssFunction`
- `MscServerFunction`
- `SgsnFunction`
- `MmeFunction`

In case of Management Based Activation the `ManagedEntity` represents the role that can be played by an instance of the following IOCs:

- `HssFunction`
- `MscServerFunction`
- `SgsnFunction`
- `GgsnFunction`
- `BmscFunction`
- `RncFunction`
- `CscfFunction`
- `MmeFunction`
- `ServingGWFunction`

In case of Cell Traffic Trace the `ManagedEntity` represents the role that can be played by an instance of the following IOCs:

- `UtranCell`
- `E-UtranCell`

## 5.4 Information relationship definitions

### 5.4.1 `relation-traceIRP-traceJob` (M)

#### 5.4.1.1 Definition

This represents the relationship between `TraceIRP` and the `TraceJob`.

#### 5.4.1.2 Roles

Name	Definition
<code>theTraceIRP</code>	It represents the <code>TraceIRP</code>
<code>theTraceJobList</code>	It represents the <code>TraceJobList</code>

### 5.4.2 `relation-traceJob-managedEntity` (M)

#### 5.4.2.1 Definition

This represents the relationship between `TraceJob` and the `ManagedEntity`.

#### 5.4.2.2 Roles

Name	Definition
<code>theManagedEntity</code>	The <code>ManagedEntity</code> , when playing this role, represents the actual network resource instance, where a <code>Trace Session</code> is activated.
<code>theTraceJob</code>	It represents the <code>TraceJob</code>

### 5.4.3 `relation-traceJob-traceRecord` (M)

#### 5.4.3.1 Definition

This represents the relationship between `TraceJob` and the `TraceRecord`.

#### 5.4.3.2 Roles

Name	Definition
<code>theTraceJob</code>	It represents the <code>TraceJob</code>
<code>theTraceRecord</code>	It represents the <code>TraceRecord</code> .



## 5.5 Information attribute definitions

### 5.5.1 Definition and legal values

Attribute Name	Definition	Legal Values
anonymizationOfMDTData	It specifies the level of anonymization for an area based MDT.	See 3GPP TS 32.422 [9]
areaScope	It specifies MDT area scope when activates an MDT job. For RLF and RCEF reporting it specifies the eNB or list of eNBs where the RLF or RCEF reports should be collected.	List of cells/TA/LA/RA for subscription based MDT or area based Logged MDT.  List of cells for area based Immediate MDT.  Cell, TA, LA, RA are mutually exclusive. One or list of eNBs for RLF and RCEFreporting
collectionPeriodRrmLte	It specifies the collection period for collecting RRM configured measurement samples for M2, M3 in LTE. The attribute is applicable only for Immediate MDT. In case this attribute is not used, it carries a null semantic.	See 3GPP TS 32.422 [9]
collectionPeriodRrmUmts	It specifies the collection period for collecting RRM configured measurement samples for M3, M4, M5 in UMTS. The attribute is applicable only for Immediate MDT. In case this attribute is not used, it carries a null semantic.	See 3GPP TS 32.422 [9]
eventThreshold	It specifies the threshold which should trigger the reporting in case A2 event reporting in LTE or 1F/1I event in UMTS. The attribute is applicable only for Immediate MDT and when reportingTrigger is configured for A2 event in LTE or 1F event or 1I event in UMTS. In case this attribute is not used, it carries a null semantic.	See 3GPP TS 32.422 [9] , 3GPP TS 25.331 [11] , 3GPP TS 36.331 [12]
jobType	It specifies the MDT mode and it specifies also whether the TraceJob represents only MDT, Logged MBSFN MDT, Trace or a combined Trace and MDT job. The attribute is applicable for Trace, MDT, RCEF and RLF reporting.	See 3GPP TS 32.422 [9]
listOfInterfaces	It specifies the interfaces that need to be traced in the given ManagedEntityFunction.The attribute is applicable only for Trace. In case this attribute is not used, it carries a null semantic.	See 3GPP TS 32.422 [9]
listOfMeasurements	It specifies the UE measurements that shall be collected in an Immediate MDT job. The attribute is applicable only for Immediate MDT. In case this attribute is not used, it carries a null semantic.	See 3GPP TS 32.422 [9]
listOfNETypes	It specifies in which type of ManagedFunction the trace should be activated. The attribute is applicable only for Trace with Signalling Based Trace activation. In case this attribute is not used, it carries a null semantic.	See 3GPP TS 32.422 [9]
loggingDuration	It specifies how long the MDT configuration is valid at the UE in case of Logged MDT. The attribute is applicable only for Logged MDT and Logged MBSFN MDT. In case this attribute is not used, it carries a null semantic.	See 3GPP TS 32.422 [9]
loggingInterval	It specifies the periodicity for Logged MDT. The attribute is applicable only for Logged MDT and Logged MBSFN MDT. In case this attribute is not used, it carries a null semantic .	See 3GPP TS 32.422 [9], 3GPP TS 25.331 [11] , 3GPP TS 36.331 [12]
measurementPeriodLTE	It specifies the measurement period for the Data Volume and Scheduled IP throughput measurements for MDT taken by the eNB. The attribute is applicable only for Immediate MDT. In case this attribute is not used, it carries a null semantic.	See 3GPP TS 32.422 [9]

Attribute Name	Definition	Legal Values
measurementPeriodUMTS	It specifies the measurement period for the Data Volume and Throughput measurements for MDT taken by RNC. The attribute is applicable only for Immediate MDT. In case this attribute is not used, it carries a null semantic.	See 3GPP TS 32.422 [9]
measurementQuantity	It specifies the measurements that are collected in an MDT job for a UMTS MDT configured for event triggered reporting.	See 3GPP TS 32.422 [9]
pLMNTarget	It specifies which PLMN that the subscriber of the session to be recorded uses as selected PLMN.	See 3GPP TS 32.422 [9]
positionigMethod	It specifies what positioning method should be used in the MDT job.	See 3GPP TS 32.422 [9]
reportAmount	It specifies the number of measurement reports that shall be taken for periodic reporting while the UE is in connected. The attribute is applicable only for Immediate MDT and when reportingTrigger is configured for periodical measurements. In case this attribute is not used, it carries a null semantic.	See 3GPP TS 32.422 [9]
reportInterval	It specifies the interval between the periodical measurements that shall be taken when the UE is in connected mode. The attribute is applicable only for Immediate MDT and when reportingTrigger is configured for periodical measurements. In case this attribute is not used, it carries a null semantic.	See 3GPP TS 32.422 [9]
reportingTrigger	It specifies whether periodic or event based measurements should be collected. The attribute is applicable only for Immediate MDT and when the listOfMeasurements is configured for M1 (for both UMTS and LTE) or M2 (only for UMTS). In case this attribute is not used, it carries a null semantic.	See 3GPP TS 32.422 [9]
traceCollectionEntityAddress	It specifies the address of the Trace Collection Entity within an IRPManager. The attribute is applicable for both Trace and MDT	See 3GPP TS 32.422 [9]
traceDepth	It specifies the trace depth of the ManagedEntityFunction instances. The attribute is applicable only for Trace. In case this attribute is not used, it carries a null semantic.	See 3GPP TS 32.422 [9]
traceReference	A globally unique identifier, which uniquely identifies the Trace Session that is created by the TraceJob. In case of shared network, it is the MCC and MNC of the Participating Operator that request the trace session that shall be provided. The attribute is applicable for both Trace and MDT.	See 3GPP TS 32.422 [9]
traceTarget	It specifies the target object of the Trace and MDT. The attribute is applicable for both Trace and MDT. This attribute includes the ID type of the target and the ID value.	The ID type may be IMSI or IMEI or IMEISV or Public ID or Private ID or a Cell or an eNB or a RNC. The ID value can be a string.  If the ID type is a Cell, the ID value can be identified by its DN id.  IMSI, IMEI, IMEISV, Public ID, cell, eNB and RNC are mutually exclusive.
triggeringEvent	It specifies the triggering event parameter of the trace session. The attribute is applicable only for Trace. In case this attribute is not used, it carries a null semantic.	See 3GPP TS 32.422 [9]

Attribute Name	Definition	Legal Values
mBSFNAreaList	The MBSFN Area consists of a MBSFN Area ID and Carrier Frequency (EARFCN). The target MBSFN area List can have up to 8 entries. This parameter is applicable only if the job type is Logged MBSFN MDT.	See 3GPP TS 32.422 [9]

## 6 Interface Definition

### 6.1 Class diagram representing interfaces

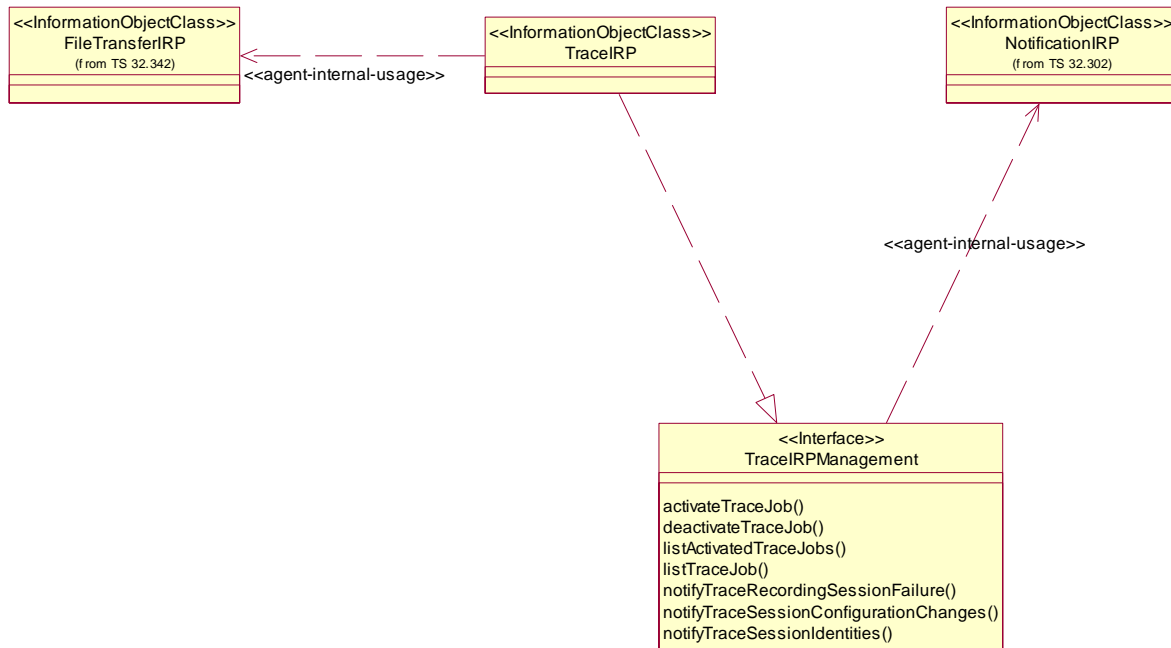

Figure 6.1: Class Diagram

### 6.2 Generic rules

- **Rule 1:** each operation with at least one input parameter supports a pre-condition `valid_input_parameter` which indicates that all input parameters shall be valid with regards to their information type. Additionally, each such operation supports an exception `operation_failed_invalid_input_parameter` which is raised when pre-condition `valid_input_parameter` is false. The exception has the same entry and exit state.
- **Rule 2:** each operation with at least one optional input parameter supports a set of pre-conditions `supported_optional_input_parameter_xxx` where "xxx" is the name of the optional input parameter and the pre-condition indicates that the operation supports the named optional input parameter. Additionally, each such operation supports an exception `operation_failed_unsupported_optional_input_parameter_xxx` which is raised when (a) the pre-condition `supported_optional_input_parameter_xxx` is false and (b) the named optional input parameter is carrying information. The exception has the same entry and exit state.
- **Rule 3:** each operation shall support a generic exception `operation_failed_internal_problem` which is raised when an internal problem occurs and that the operation cannot be completed. The exception has the same entry and exit state.

NOTE: These rules are mapped at the solution set level. Pre-conditions and exceptions, generated by these rules, need not appear explicitly in the present document.

## 6.3 TraceIRPManagement (M)

### 6.3.1 Operation activateTraceJob (M)

#### 6.3.1.1 Definition

This operation support IRPManager 's request to create a TraceJob through Itf-N.

Once the TraceJob has been created, the attributes of the TraceJob will not be modified during the lifetime of the TraceJob.

One TraceJob can manage Trace Sessions in one or more ManagedEntity.

### 6.3.1.2 Input parameters

Parameter Name	Qualifier	Information type	Comment
iOCInstance	M	ManagedEntity.objectInstance	It specifies the DN of ManagedEntity instance where Trace Session is to be activated.
listOfInterfaces	O	TraceJob.listOfInterfaces	
listOfNeTypes	CM	TraceJob.listOfNeTypes	It specifies the type of ManagedFunctions.
traceDepth	M	TraceJob.traceDepth	It shows the traceDepth set to the Trace Session.
traceReference	M	TraceJob.traceReference	It identifies the TraceSession.
traceTarget	M	TraceJob.traceTarget	IMSI or IMEI or IMEISV or Public ID or Private ID or a Cell(identified by its DN id) or an eNB or a RNC. IMSI, IMEI, IMEISV, Public ID, Cell, eNB and RNC are mutually exclusive.
triggeringEvent	CO	TraceJob.triggeringEvent	
traceCollectionEntityAddress	CM,CO	TraceJob.traceCollectionEntityAddress	It specifies the address to the Trace Collection Entity that is associated to the TraceJob. See 3GPP TS 32.442 [9].
jobType	M	TraceJob.jobType	It specifies the type of the TraceJob
areaScope	CM	TraceJob.areaScope	It specifies MDT area (Cells/TA/RA/LA) where the Logged MDT measurements or Logged MBSFN MDT shall be collected. It specifies one or list of eNBs where the RLF or RCEF reports shall be collected. It specifies MDT area (list of cells) where the Immediate MDT measurements shall be collected.
listOfMeasurements	CM	TraceJob.listOfMeasurements	It specifies the measurements to be collected from the UE
reportingTrigger	CM	TraceJob.reportingTrigger	It specifies the reporting trigger (event based reporting or periodic reporting) in the UE.
reportInterval	CM	TraceJob.reportInterval	It specifies the interval between the periodical measurements to be taken by the UE.



Parameter Name	Qualifier	Information type	Comment
reportAmount	CM	TraceJob.reportAmount	It specifies the number of measurement reports to be taken in periodical reporting in the UE
eventThreshold	CM	TraceJob.eventThreshold	It specifies the threshold triggering the reporting in case of A2 event reporting in LTE or 1F/1I event reporting in UMTS.
loggingInterval	CM	TraceJob.loggingInterval	It specifies the periodicity of Logged MDT or Logged MBSFN MDT.
loggingDuration	CM	TraceJob.loggingDuration	It specifies the duration of the Logged MDT or Logged MBSFN MDT at the UE.
anonymizationOfMDTData	CM	TraceJob.anonymizationOfMDTData	It specifies the anonymization level of an area based MDT.
measurementPeriodLTE	CM	TraceJob.measurementPeriodLTE	It specifies the measurement period for the Data Volume and Scheduled IP Throughput measurements in the eNB within an Immediate MDT job.
measurementPeriodUMTS	CM	TraceJob.measurementPeriodUMTS	It specifies the measurement period for the Data Volume and Throughput measurements in the RNC within an Immediate MDT job.
collectionPeriodRrmUmts	CM	TraceJob.collectionPeriodRrmUmts	It specifies the collection period for M3, M4, M5 in UMTS within an Immediate MDT job.
collectionPeriodRrmLte	CM	TraceJob.collectionPeriodRrmLte	It specifies the collection period for M2, M3 in LTE within an Immediate MDT job.
positioningMethod	CO	TraceJob.positioningMethod	It specifies the positioning method to be used for the Immediate MDT job.
measurementQuantity	CM	TraceJob.measurementQuantity	It specifies which measurement should be collected in an event triggered measurement collection.
pLMNTarget	CM	TraceJob.pLMNTarget	It specifies which PLMN that the subscriber of the session to be recorded uses as selected PLMN.

Parameter Name	Qualifier	Information type	Comment
mBSFNAreaList	CM	TraceJob. mBSFNAreaList	It specifies MBSFN Area(s) for MBSFN MDT measurement logging.

### 6.3.1.3 Output parameters

Parameter Name	Qualifier	Matching Information	Comment
status	M	ENUM (Success, Failure, PartialSuccess)	
unsupportedList	M	List of <ManagedEntity, TraceDepth, ListOfInterfaces, TraceTarget, areaScope, listOfMeasurements, reportingTrigger, reportInterval, reportAmount, eventThreshold, loggingInterval, loggingDuration, anonymizationOfMDTData, measurementPeriodLTE, measurementPeriodUMTS, positioningMethod, measurementQuantity reason, pLMNTarget)	It specifies what attributes are not supported when a Trace Session is activated. The list can contain one or all of the elements and relevant only for error cases.

### 6.3.1.4 Pre-condition

validTraceReference AND validTraceDepth AND validTraceTarget

Assertion Name	Definition
validTraceDepth	The traceDepth input parameter is valid.
validTraceReference	The traceReference given is not matching to any existing traceReference value in the activated TraceJobs.
validTraceTarget	The traceTarget input parameter is valid.

### 6.3.1.5 Post-condition

traceSessionActivated

Assertion Name	Definition
traceSessionActivated	The Trace Session identified by the traceReference is activated in the given ManagedEntity instances.

### 6.3.1.6 Exceptions

Exception Name	Definition
invalidTraceDepth	<b>Condition:</b> (validTraceDepth) is false. <b>Returned Information:</b> output parameter status is set to "Failure". <b>Exit state:</b> Entry State.
invalidTraceTarget	<b>Condition:</b> (validTraceTarget) is false. <b>Returned Information:</b> output parameter status is set to "Failure". <b>Exit state:</b> Entry State.
notuniqueTraceReference	<b>Condition:</b> (validTraceReference) is false. <b>Returned Information:</b> output parameter status is set to "Failure". <b>Exit state:</b> Entry State.
pLMNTargetNotSupported	<b>Condition:</b> (validPLMNTarget) is false. <b>Returned Information:</b> output parameter status is set to "Failure". <b>Exit state:</b> Entry State.

### 6.3.1.7 Constraints

Name	Definition
listOfNeTypes	It is a Signalling Based Activated trace that is requested.
traceCollectionEntityAddress CM, CO qualifier	Mandatory when tracing in EPS is supported; Mandatory when MDT is supported; Optional when tracing in UMTS is supported.
areaScope	MDT is supported or RLF or RCEF reporting is supported
listOfMeasurements	MDT is supported
reportingTrigger	MDT is supported
reportInterval	MDT is supported
reportAmount	MDT is supported
eventThreshold	MDT is supported
loggingInterval	MDT is supported
loggingDuration	MDT is supported
listOfMeasurements	MDT is supported
traceDepth	Trace is supported
triggeringEvent	Trace is supported
anonymizationOfMDTData	MDT is supported
measurementPeriodLTE	MDT is supported
measurementPeriodUMTS	MDT is supported
collectionPeriodRrmUmts	MDT is supported
collectionPeriodRrmLte	MDT is supported
positioningMethod	MDT is supported

pLMNTarget	Several PLMNs are supported in the RAN and a Management Based Activation Trace Session is requested.
mBSFNAreaList	Logged MBSFN MDT is supported

## 6.3.2 Operation deactivateTraceJob (M)

### 6.3.2.1 Definition

This operation supports IPRManager's request to stop a TraceJob through Itf-N. When this operation is received in the TraceIRP the TraceJob shall deactivate the requested Trace Session in the requested ManagedEntity instances.

### 6.3.2.2 Input parameters

Parameter Name	Qualifier	Information type	Comment
traceReference	M	TraceJob.traceReference	This is a unique ID of the TraceJob
traceTarget	M	TraceJob.traceTarget	(IMSI or IMEI or IMEISV or Public ID or Private ID or a Cell(identified by its DN id) or an eNB or a RNC. IMSI, IMEI, IMEISV,Public ID, Cell, eNB and RNC are mutually exclusive.

### 6.3.2.3 Output parameters

Parameter Name	Qualifier	Matching Information	Comment
status	M	ENUM (Success, Failure)	The operation may fail because of a specified or an unspecified reason.
traceRecordingSessionReference	CM		This would indicate if a Trace Recording Session is ongoing when the deactivation command has been given.

### 6.3.2.4 Pre-condition

validTraceReference

Assertion Name	Definition
validTraceReference	The TraceReference input parameter is valid, which means that the TraceIRP is aware of such TraceJob, which has this traceReference value and is aware of the ManagedEntity holding such Trace Session.

### 6.3.2.4 Post-condition

TraceSessionisdeactivated

Assertion Name	Definition
TraceSessionisdeactivate	The Trace Session identified by the traceReference is deactivated in the requested ManagedEntity instance and the TraceJob is stopped.

### 6.3.2.6 Exceptions

Exception Name	Definition
notuniqueTraceReference	<b>Condition:</b> (validTraceReference) is false. <b>Returned Information:</b> output parameter status is set to "Failure". <b>Exit state:</b> Entry State.

## 6.3.3 Operation listTraceJob (M)

### 6.3.3.1 Definition

This operation support IPRManager 's request to list the parameters of a specific TraceJob through Itf-N.

### 6.3.3.2 Input parameters

Parameter Name	Qualifier	Information type	Comment
traceReference	M	TraceJob.traceReference	It specifies the Trace Session that is requested for interrogation.

## 6.3.3.3 Output parameters

Parameter Name	Qualifier	Matching Information	Comment
iOCInstance	M	ManagedElement.objectInstance	It specifies the DN of ManagedElement instance where a Trace Session is activated.
listOfInterfaces	O	TraceJob.listOfInterfaces	It specifies the list of interfaces trace control and configuration parameter that is associated with the TraceJob. See 3GPP TS 32.422 [9]
Status	M	ENUM (Success, Failure)	The operation may fail because of a specified or an unspecified reason.
traceDepth	M	TraceJob.traceDepth	It shows the traceDepth trace control and configuration parameter that is associated to the TraceJob.
traceRecordingSessionReference	CM		This would indicate if a Trace Recording Session is ongoing when the deactivation command has been given.
traceTarget	M	TraceJob.traceTarget	IMSI or IMEI or IMEISV or Public ID or Private ID or a Cell (identified by its DN id) or an eNB or a RNC. IMSI, IMEI, IMEISV, Public ID, Cell, eNB and RNC are mutually exclusive.
triggeringEvent	CO	TraceJob.triggeringEvent	It specifies the triggering event trace control and configuration parameter that is associated to the TraceJob. See 3GPP TS 32.422 [9].
traceCollectionEntityAddress	CM,CO	TraceJob.traceCollectionEntityAddress	It specifies the address to the Trace Collection Entity that is associated to the TraceJob. See 3GPP TS 32.422 [9].
jobType	M	TraceJob.jobType	It specifies the type of the TraceJob. It can be one of the following: Trace, MDT data collection, Trace and MDT data collection, RLF reporting, RCEF reporting.
areaScope	CM	TraceJob.areaScope	It specifies MDT area (Cells/TA/RA/LA) where the Logged MDT measurements shall be collected. It specifies one or list of eNBs where the RLF reports, or RCEF reports shall be collected. It specifies MDT area (list of cells) where the Immediate MDT measurements shall be collected.
listOfMeasurements	CM	TraceJob.listofMeasurements	It specifies the measurements to be collected from the UE
reportingTrigger	CM	TraceJob.reportingTrigger	It specifies the reporting trigger (event based reporting or periodic reporting) in the UE.
reportInterval	CM	TraceJob.reportInterval	It specifies the interval between the periodical measurements to be taken by the UE.
reportAmount	CM	TraceJob.reportAmount	It specifies the number of measurement reports to be taken in periodical reporting in the UE
eventThreshold	CM	TraceJob.eventThreshold	It specifies the threshold triggering the reporting in case of A2 event reporting in LTE or 1F/1I event reporting in UMTS in LTE or 1F/1I event reporting in UMTS..
loggingInterval	CM	TraceJob.loggingInterval	It specifies the periodicity of the logging for downlink pilot strength measurement in Logged MDT.
loggingDuration	CM	TraceJob.loggingDuration	It specifies the duration of the Logged MDT at the UE.
anonymizationOfMDTData	CM	TraceJob.anonymizationOfMDTData	It specifies the anonymization level of an area based MDT.
measurementPeriodLTE	CM	TraceJob.measurementPeriodLTE	It specifies the measurement period for the Data Volume and Scheduled IP Throughput measurements in the eNB within an Immediate MDT job.
measurementPeriodUMTS	CM	TraceJob.measurementPeriodUMTS	It specifies the measurement period for the Data Volume and Throughput measurements in the RNC within an Immediate MDT job.
collectionPeriodRrmUmts	CM	TraceJob.collectionPeriodRrmUmts	It specifies the collection period for M3, M4, M5 in UMTS within an Immediate MDT job.
collectionPeriodRrmLte	CM	TraceJob.collectionPeriodRrmLte	It specifies the collection period for M2, M3 in LTE within an Immediate MDT job.
positioningMethod	CO	TraceJob.positioningMethod	It specifies the positioning method to be used for the Immediate MDT job.
measurementQuantity	CM	TraceJob.measurementQuantity	It specifies which measurement should be collected in an event triggered measurement collection.
pLMNTarget	CM	TraceJob.pLMNTarget	It specifies which PLMN that the subscriber of the session to be recorded uses as selected PLMN.
mBSFNAreaList	CM	TraceJob.mBSFNAreaList	It specifies MBSFN Area(s) for MBSFN MDT measurement logging.

### 6.3.3.4 Pre-condition

validTraceReference

Assertion Name	Definition
validTraceReference	The traceReference input parameter is valid, which means that the TraceIRP is aware of such TraceJob, which has this traceReference value and is aware of the ManagedEntity holding such Trace Session.

### 6.3.3.5 Post-condition

TraceSessionFound

Assertion Name	Definition
TraceSessionFound	The TraceIRP has found the requested TraceJob with the traceReference and can read the configured parameters.

### 6.3.3.6 Exceptions

Exception Name	Definition
notuniqueTraceReference	<b>Condition:</b> (validTraceReference) is false. <b>Returned Information:</b> output parameter status is set to "Failure". <b>Exit state:</b> Entry State.

### 6.3.3.7 Constraints

Name	Definition
traceCollectionEntityAddress CM,CO qualifier	Mandatory when tracing in EPS is supported; Mandatory when MDT is supported; Optional when tracing in UMTS is supported.
anonymizationOfMDTData	MDT is supported
areaScope	MDT is supported or RLF reporting is supported
listOfMeasurements	MDT is supported
reportingTrigger	MDT is supported
reportInterval	MDT is supported
reportAmount	MDT is supported
eventThreshold	MDT is supported
loggingInterval	MDT is supported
loggingDuration	MDT is supported
traceDepth	Trace is supported
triggeringEvent	Trace is supported
measurementPeriodLTE	MDT is supported
measurementPeriodUMTS	MDT is supported
collectionPeriodRrmUmts	MDT is supported

collectionPeriodRrmLte	MDT is supported
positioningMethod	MDT is supported
measurementQuantity	MDT is supported
pLMNTarget	Several PLMNs are supported in the RAN and a Management Based Activation Trace Session is activated.
mBSFNAreaList	Logged MBSFN MDT is supported

## 6.3.4 Operation listActivatedTraceJobs (M)

### 6.3.4.1 Definition

This operation support IRPManager 's request to list all the activated TraceJobs through Itf-N.

### 6.3.4.2 Input parameters

No input parameters for this operation.

### 6.3.4.3 Output parameters

Parameter Name	Qualifier	Matching Information	Comment
traceReferenceList	M	List of < TraceJob.traceReference.objectinstance >	The TraceReferenceList provides the identification of each activated Trace Session. If no TraceReference can be found, then this list is empty and status is "Success"
status	M	ENUM (Success, Failure)	The operation may fail because of a specified or an unspecified reason.

## 6.3.5 Notification notifyTraceRecordingSessionFailure (O)

### 6.3.5.1 Definition

The TraceIRP notifies all subscribed IRPManagers and the Trace Collection Entity (if its address is provided) if a Trace Recording Session in a ManagedEntity has not been started due to any problem.

### 6.3.5.2 Input parameters

Parameter Name	Qualifiers	Matching Information	Comment
objectClass	M,Y	TraceIRP.objectClass	Notification header
objectInstance	M,Y	TraceIRP.objectInstance	Notification header
eventTime	M,Y	--	Notification header
notificationType	M,Y	"notifyTraceRecordingSessionFailure"	Notification header
systemDN	M,Y	--	Notification header
notificationID	O,Y	--	Notification header
traceRecordingSessionReference	O,N	--	The Trace Recording Session Reference may be visible only in signalling based activation.
traceReference	M,Y	TraceJob.traceReference	
reason	O,N	--	

### 6.3.5.3 Triggering event

#### 6.3.5.3.1 From state

internalProblemInManagedEntity



Assertion Name	Definition
internalProblemInManagedEntity	Because of an internal problem the ManagedEntity cannot start a Trace Recording Session.

### 6.3.5.3.2 To state

newNotificationReported

Assertion Name	Definition
newNotificationReported	The " notifyTraceRecordingSessionFailure " notification is emitted to the subscribed IRPManager(s).

## 6.3.6 Notification notifyTraceSessionLocalActivation (M)

### 6.3.6.1 Definition

The TraceIRP notifies all subscribed IRPManagers if a Trace Session is configured by the Element Manager.

### 6.3.6.2 Input parameters

Parameter Name	Qualifiers	Matching Information	Comment
objectClass	M,Y	TraceIRP.objectClass	Notification header
objectInstance	M,Y	TraceIRP.objectInstance	Notification header
eventTime	M,Y	--	Notification header
notificationType	M,Y	"notifyTraceSessionLocalActivation"	Notification header
systemDN	M,Y	--	Notification header
notificationID	O,Y	--	Notification header
traceReference	M,Y	TraceJob.traceReference	
traceTarget	M,Y	TraceJob.traceTarget	
iOCInstance	M,Y	ManagedEntity.objectInstance	

### 6.3.6.3 Triggering event

#### 6.3.6.3.1 From state

unknownTraceReference

Assertion Name	Definition
unknownTraceReference	The TraceIRP has detected a traceReference associated to a Trace Session in a ManagedEntity that is not initiated via the Itf-N.

#### 6.3.6.3.2 To state

newNotificationReported

Assertion Name	Definition
newNotificationReported	The " notifyTraceSessionLocalActivation " notification is emitted to the subscribed IRPManager(s).

## 6.3.7 Notification notifyTraceSessionIdentities (CM)

### 6.3.7.1 Definition

The TraceIRP or the MmeFunction notifies the Trace Collection Entity about the identities of the subscriber and Equipment in case of tracing a session in E-UTRAN only.

### 6.3.7.2 Input parameters

Parameter Name	Qualifiers	Matching Information	Comment
objectClass	M,Y	TraceIRP.objectClass, or MmeFunction.objectClass	Notification header
objectInstance	M,Y	TraceIRP.objectInstance, or MmeFunction.objectClass	Notification header
eventTime	M,Y	--	Notification header
notificationType	M,Y	"notifyTraceSessionIds"	Notification header
systemDN	M,Y	--	Notification header
notificationID	O,Y	--	Notification header
traceReference	M,Y	TraceJob.traceReference	
traceRecordingSessionReference	M,Y	TraceJob.traceRecordingSessionReference	
traceTarget	M,Y	TraceJob.traceTarget	

### 6.3.7.3 Triggering event

#### 6.3.7.3.1 From state

FFS

Assertion Name	Definition
FFS	FFS

#### 6.3.7.3.2 To state

FFS

Assertion Name	Definition
FFS	FFS

### 6.3.7.4 Constraint

Name	Definition
notifyTraceSessionIdentities Notification CM qualifier	Tracing is performed only in E-UTRAN

## Annex A (informative): Change history

Change history								
Date	TSG #	TSG Doc.	CR	Rev	Subject/Comment	Cat	Old	New
Apr 2007	S5_52	S5-070445	--	--	Submitted by SA5 prior SA#36 for Information with the intention to get SA#36 Rel-7 Approval for this TS and the CORBA Solution Set TS 32.443	--	1.0.0	
Jun 2007	SP-36	SP-070288	--	--	Submitted to SA#36 for Approval	--	1.0.0	7.0.0
Mar 2008	SP-39	SP-080058	0001	--	Standardize the DN id of UTRAN cell as the identification for the trace target in case of cell traffic trace	F	7.0.0	7.1.0
Dec 2008	SP-42	SP-080846	0002	--	Introducing EPS in Subscriber and Equipment Trace	C	7.1.0	8.0.0
Dec 2009	--	--	--	--	Upgrade to Release 9	--	8.0.0	9.0.0
Jan 2010	--	--	--	--	Removal of track changes and correction of change history	--	9.0.0	9.0.1
Dec 2010	SP-50	SP-100833	003	1	Correcting the Identification of IMS Subscriber Tracing - Align with 32.421	F	9.0.1	10.0.0
Mar 2011	SP-51	SP-110102	004	-	Adding Minimization of Drive Tests (MDT) to Trace IRP	B	10.0.0	10.1.0
May 2011	SP-52	SP-110292	007	1	Add areascopes parameter as a MDT configuration	F	10.1.0	10.2.0
May 2011	SP-52	SP-110286	008	1	Modify the definition of traceTarget	C	10.2.0	11.0.0
Dec 2011	SP-54	SP-110716	013	1	Add RLF reporting configuration -Align with 32.422	B	11.0.0	11.1.0
Dec 2011	SP-54	SP-110715	015	2	Support multiple cells in area based MDT	A	11.0.0	11.1.0
Dec 2011	SP-54	SP-110715	017	2	Add TCE address for UTRAN MDT activation	A	11.0.0	11.1.0
March 2012	SP-55	SP-120053	020	1	Inconsistency correction on trace target -Align with 32.422	A	11.1.0	11.2.0
June-2012	SP-56	SP-120368	0215	--	Alignment of the Anonymization parameter with TS 32.422	A	11.2.0	11.3.0
Sep-2012	SP-57	SP-120571	0216	1	Adding new MDT configuration parameters to align with TS 37.320 and TS 32.422	B	11.3.0	11.4.0
Sep-2012	SP-57	SP-120571	0219	1	Add missing threshold parameter for UMTS event triggered measurements	A	11.3.0	11.4.0
Dec-2012	SP-58	SP-120795	0217	2	Add RCEF reporting	B	11.4.0	11.5.0
		SP-120795	0222	3	Correction on scope, references and abbreviations	F		
		SP-120794	0226	1	Correction of UMTS M2 reporting trigger configuration -Align with 32.422	A		
		SP-120796	0227	1	Introducing common MDT measurement period attribute in Trace IRP	B		
		SP-120796	0228	1	Addition of Network Sharing	C		
		SP-120795	0229	1	Add measurement M7	B		
Mar-2013	SP-59	SP-130057	0231	1	Editorial corrections in 32.442	F	11.5.0	11.6.0
Sep-2014	SP-65	SP-140558	0232	-	Addition of missing parameters relating to RCEF	F	11.6.0	11.7.0
Oct 2014					Automatic upgrade (MCC)		11.7.0	12.0.0
Dec 2014	SP-66	SP-140800	0237	-	Clarify the Trace Reference for shared networks	B	12.0.0	12.1.0
Jun 2015	SP-68	SP-150315	0238	2	Multi-Broadcast Single Frequency Network (MBSFN) Minimization of Drive Tests (MDT) enhancement.	B	12.1.0	13.0.0

Change history							
Date	Meeting	Tdoc	CR	Rev	Cat	Subject/Comment	New version
2016-12						Correction of LTE logo (MCC)	13.0.1
2017-04	SA#75	-	-	-	-	Promotion to Release 14 without technical change	14.0.0
2018-06	-	-	-	-	-	Update to Rel-15 version (MCC)	15.0.0
2020-07	-	-	-	-	-	Update to Rel-16 version (MCC)	16.0.0

---

# History

<b>Document history</b>		
V16.0.0	August 2020	Publication