

ETSI TS 133 105 V15.0.0 (2018-07)



**Universal Mobile Telecommunications System (UMTS);  
LTE;  
3G Security;  
Cryptographic algorithm requirements  
(3GPP TS 33.105 version 15.0.0 Release 15)**



---

**Reference**

RTS/TSGS-0333105vf00

---

**Keywords**

LTE,SECURITY,UMTS

**ETSI**

---

650 Route des Lucioles  
F-06921 Sophia Antipolis Cedex - FRANCE

Tel.: +33 4 92 94 42 00 Fax: +33 4 93 65 47 16

Siret N° 348 623 562 00017 - NAF 742 C  
Association à but non lucratif enregistrée à la  
Sous-Préfecture de Grasse (06) N° 7803/88

---

**Important notice**

The present document can be downloaded from:

<http://www.etsi.org/standards-search>

The present document may be made available in electronic versions and/or in print. The content of any electronic and/or print versions of the present document shall not be modified without the prior written authorization of ETSI. In case of any existing or perceived difference in contents between such versions and/or in print, the only prevailing document is the print of the Portable Document Format (PDF) version kept on a specific network drive within ETSI Secretariat.

Users of the present document should be aware that the document may be subject to revision or change of status.

Information on the current status of this and other ETSI documents is available at

<https://portal.etsi.org/TB/ETSIDeliverableStatus.aspx>

If you find errors in the present document, please send your comment to one of the following services:

<https://portal.etsi.org/People/CommiteeSupportStaff.aspx>

---

**Copyright Notification**

No part may be reproduced or utilized in any form or by any means, electronic or mechanical, including photocopying and microfilm except as authorized by written permission of ETSI.

The content of the PDF version shall not be modified without the written authorization of ETSI.

The copyright and the foregoing restriction extend to reproduction in all media.

© ETSI 2018.

All rights reserved.

**DECT™**, **PLUGTESTS™**, **UMTS™** and the ETSI logo are trademarks of ETSI registered for the benefit of its Members.  
**3GPP™** and **LTE™** are trademarks of ETSI registered for the benefit of its Members and  
of the 3GPP Organizational Partners.

**oneM2M** logo is protected for the benefit of its Members.

**GSM®** and the GSM logo are trademarks registered and owned by the GSM Association.

---

# Intellectual Property Rights

## Essential patents

IPRs essential or potentially essential to normative deliverables may have been declared to ETSI. The information pertaining to these essential IPRs, if any, is publicly available for **ETSI members and non-members**, and can be found in ETSI SR 000 314: *"Intellectual Property Rights (IPRs); Essential, or potentially Essential, IPRs notified to ETSI in respect of ETSI standards"*, which is available from the ETSI Secretariat. Latest updates are available on the ETSI Web server (<https://ipr.etsi.org/>).

Pursuant to the ETSI IPR Policy, no investigation, including IPR searches, has been carried out by ETSI. No guarantee can be given as to the existence of other IPRs not referenced in ETSI SR 000 314 (or the updates on the ETSI Web server) which are, or may be, or may become, essential to the present document.

## Trademarks

The present document may include trademarks and/or tradenames which are asserted and/or registered by their owners. ETSI claims no ownership of these except for any which are indicated as being the property of ETSI, and conveys no right to use or reproduce any trademark and/or tradename. Mention of those trademarks in the present document does not constitute an endorsement by ETSI of products, services or organizations associated with those trademarks.

---

# Foreword

This Technical Specification (TS) has been produced by ETSI 3rd Generation Partnership Project (3GPP).

The present document may refer to technical specifications or reports using their 3GPP identities, UMTS identities or GSM identities. These should be interpreted as being references to the corresponding ETSI deliverables.

The cross reference between GSM, UMTS, 3GPP and ETSI identities can be found under <http://webapp.etsi.org/key/queryform.asp>.

---

# Modal verbs terminology

In the present document "**shall**", "**shall not**", "**should**", "**should not**", "**may**", "**need not**", "**will**", "**will not**", "**can**" and "**cannot**" are to be interpreted as described in clause 3.2 of the [ETSI Drafting Rules](#) (Verbal forms for the expression of provisions).

"**must**" and "**must not**" are **NOT** allowed in ETSI deliverables except when used in direct citation.

# Contents

Intellectual Property Rights .....	2
Foreword.....	2
Modal verbs terminology.....	2
Foreword.....	5
1 Scope .....	6
2 References .....	6
3 Definitions, symbols, abbreviations and conventions .....	6
3.1 Definitions .....	6
3.2 Symbols.....	7
3.3 Abbreviations .....	7
3.4 Conventions.....	7
4 General algorithm requirements .....	8
4.1 Resilience .....	8
4.2 World-wide availability and use.....	8
5 Functional algorithm requirements .....	8
5.1 Authentication and key agreement .....	8
5.1.1 Overview .....	8
5.1.1.1 Generation of quintets in the AuC .....	8
5.1.1.2 Authentication and key derivation in the USIM.....	9
5.1.1.3 Generation of re-synchronisation token in the USIM .....	9
5.1.1.4 Re-synchronisation in the HLR/AuC .....	10
5.1.2 Use .....	10
5.1.3 Allocation .....	10
5.1.4 Extent of standardisation .....	10
5.1.5 Implementation and operational considerations.....	11
5.1.6 Type of algorithm .....	11
5.1.6.1 f0 .....	11
5.1.6.2 f1 .....	11
5.1.6.3 f1* .....	11
5.1.6.4 f2 .....	11
5.1.6.5 f3 .....	11
5.1.6.6 f4 .....	11
5.1.6.7 f5 .....	11
5.1.6.8 f5* .....	12
5.1.7 Interface .....	12
5.1.7.1 K.....	12
5.1.7.2 RAND .....	12
5.1.7.3 SQN.....	12
5.1.7.4 AMF.....	12
5.1.7.6 MAC-A (equivalent for XMAC-A) .....	12
5.1.7.7 MAC-S (equivalent for XMAC-S).....	13
5.1.7.8 RES (or XRES) .....	13
5.1.7.9 CK.....	13
5.1.7.10 IK .....	13
5.1.7.11 AK.....	13
5.2 Data confidentiality .....	13
5.2.1 Overview .....	13
5.2.2 Use .....	14
5.2.3 Allocation .....	14
5.2.4 Extent of standardisation .....	14
5.2.5 Implementation and operational considerations.....	14
5.2.6 Type of algorithm .....	15
5.2.7 Interfaces to the algorithm .....	15
5.2.7.1 CK.....	15

5.2.7.2	COUNT-C .....	15
5.2.7.3	BEARER .....	16
5.2.7.4	DIRECTION .....	16
5.2.7.5	LENGTH .....	16
5.2.7.6	KEYSTREAM .....	16
5.2.7.7	PLAINTEXT .....	16
5.2.7.8	CIPHERTEXT .....	17
5.3	Data integrity .....	17
5.3.1	Overview .....	17
5.3.2	Use .....	17
5.3.3	Allocation .....	18
5.3.4	Extent of standardisation .....	18
5.3.5	Implementation and operational considerations.....	18
5.3.6	Type of algorithm .....	18
5.3.7	Interface .....	18
5.3.7.1	IK .....	18
5.3.7.2	COUNT-I .....	18
5.3.7.3	FRESH .....	18
5.3.7.4	MESSAGE .....	18
5.3.7.5	DIRECTION .....	19
5.3.7.6	MAC-I (and equivalently XMAC-I) .....	19
6	Use of the algorithm specifications .....	19
6.1	Ownership .....	19
6.2	Design authority .....	19
6.3	Users of the specification .....	19
6.4	Licensing .....	19
6.5	Management of the specification.....	19
7	Algorithm specification and test data requirements .....	20
7.1	Specification of the algorithm .....	20
7.2	Implementors test data.....	20
7.3	Design conformance test data.....	20
7.4	Format and handling of deliverables .....	20
8	Quality assurance requirements.....	20
8.1	Quality assurance for the algorithm .....	20
8.2	Quality assurance for the specification and test data.....	21
8.3	Design and evaluation report.....	21
9	Summary of the design authority deliverables .....	21
<b>Annex A (informative):</b>	<b>Void .....</b>	<b>22</b>
<b>Annex B (informative):</b>	<b>Change history .....</b>	<b>23</b>
History .....		24

---

# Foreword

This Technical Specification has been produced by the 3<sup>rd</sup> Generation Partnership Project (3GPP).

The contents of the present document are subject to continuing work within the TSG and may change following formal TSG approval. Should the TSG modify the contents of the present document, it will be re-released by the TSG with an identifying change of release date and an increase in version number as follows:

Version x.y.z

where:

- x the first digit:
  - 1 presented to TSG for information;
  - 2 presented to TSG for approval;
  - 3 or greater indicates TSG approved document under change control.
- y the second digit is incremented for all changes of substance, i.e. technical enhancements, corrections, updates, etc.
- z the third digit is incremented when editorial only changes have been incorporated in the document.

---

# 1 Scope

This specification constitutes a requirements specification for the security functions which may be used to provide the network access security features defined in [1].

The specification covers the intended use of the functions, the technical requirements on the functions and the requirements as regards standardization.

For those functions that require standardization, it also covers the intended use of the algorithm specification, the requirements on test data, and quality assurance requirements on both the algorithm and its documentation.

---

# 2 References

The following documents contain provisions which, through reference in this text, constitute provisions of the present document.

- References are either specific (identified by date of publication, edition number, version number, etc.) or non-specific.
- For a specific reference, subsequent revisions do not apply.
- For a non-specific reference, the latest version applies. In the case of a reference to a 3GPP document (including a GSM document), a non-specific reference implicitly refers to the latest version of that document *in the same Release as the present document*.

- [1] 3G TS 33.102: "3rd Generation Partnership Project (3GPP); Technical Specification Group (TSG) SA; 3G Security; Security Architecture".
- [2] Wassenaar Arrangement, December 1998.
- [3] ISO/IEC 9797: "Information technology - Security techniques - Data integrity mechanism using a cryptographic check function employing a block cipher algorithm".

---

# 3 Definitions, symbols, abbreviations and conventions

## 3.1 Definitions

For the purposes of the present document, the following definitions apply:

**Confidentiality:** The property that information is not made available or disclosed to unauthorised individuals, entities or processes.

**Data integrity:** The property that data has not been altered in an unauthorised manner.

**Data origin authentication:** The corroboration that the source of data received is as claimed.

**Entity authentication:** The provision of assurance of the claimed identity of an entity.

**Key freshness:** A key is fresh if it can be guaranteed to be new, as opposed to an old key being reused through actions of either an adversary or authorised party.

## 3.2 Symbols

For the purposes of the present document, the following symbols apply:

	Concatenation
$\oplus$	Exclusive or
f0	random challenge generating function
f1	network authentication function
f1*	the re-synchronisation message authentication function;
f2	user authentication function
f3	cipher key derivation function
f4	integrity key derivation function
f5	anonymity key derivation function for normal operation
f5*	anonymity key derivation function for re-synchronisation
f8	UMTS encryption algorithm
f9	UMTS integrity algorithm

## 3.3 Abbreviations

For the purposes of the present document, the following abbreviations apply:

3GPP	3rd Generation Partnership Project
AK	Anonymity key
AuC	Authentication Centre
AUTN	Authentication token
COUNT-C	Time variant parameter for synchronisation of ciphering
COUNT-I	Time variant parameter for synchronisation of data integrity
CK	Cipher key
IK	Integrity key
IMSI	International Mobile Subscriber Identity
IPR	Intellectual Property Right
MAC	Medium access control (sublayer of Layer 2 in RAN)
MAC	Message authentication code
MAC-A	MAC used for authentication and key agreement
MAC-I	MAC used for data integrity of signalling messages
PDU	Protocol data unit
RAND	Random challenge
RES	User response
RLC	Radio link control (sublayer of Layer 2 in RAN)
RNC	Radio network controller
SDU	Signalling data unit
SQN	Sequence number
UE	User equipment
USIM	User Services Identity Module
XMAC-A	Expected MAC used for authentication and key agreement
XMAC-I	Expected MAC used for data integrity of signalling messages
XRES	Expected user response

## 3.4 Conventions

All data variables in this specification are presented with the most significant substring on the left hand side and the least significant substring on the right hand side. A substring may be a bit, byte or other arbitrary length bitstring. Where a variable is broken down into a number of substrings, the leftmost (most significant) substring is numbered 0, the next most significant is numbered 1, and so on through to the least significant.



---

## 4 General algorithm requirements

### 4.1 Resilience

The functions should be designed with a view to its continued use for a period of at least 20 years. Successful attacks with a work load significantly less than exhaustive key search through the effective key space should be impossible.

The designers of above functions should design algorithms to a strength that reflects the above qualitative requirements.

### 4.2 World-wide availability and use

Legal restrictions on the use or export of equipment containing cryptographic functions may prevent the use of such equipment in certain countries.

It is the intention that UE and USIMs which embody such algorithms should be free from restrictions on export or use, in order to allow the free circulation of 3G terminals. Network equipment, including RNC and AuC, may be expected to come under more stringent restrictions. It is the intention is that RNC and AuC which embody such algorithms should be exportable under the conditions of the Wassenaar Arrangement [2].

---

## 5 Functional algorithm requirements

### 5.1 Authentication and key agreement

#### 5.1.1 Overview

The mechanism for authentication and key agreement described in clause 6.3 of [1] requires the following cryptographic functions:

f0	the random challenge generating function;
f1	the network authentication function;
f1*	the re-synchronisation message authentication function;
f2	the user authentication function;
f3	the cipher key derivation function;
f4	the integrity key derivation function;
f5	the anonymity key derivation function for normal operation;
f5*	the anonymity key derivation function for re-synchronisation.

#### 5.1.1.1 Generation of quintets in the AuC

To generate a quintet the HLR/AuC:

- computes a message authentication code for authentication  $MAC-A = f1_K(SQN \parallel RAND \parallel AMF)$ , an expected response  $XRES = f2_K(RAND)$ , a cipher key  $CK = f3_K(RAND)$  and an integrity key  $IK = f4_K(RAND)$  where  $f4$  is a key generating function.
- If SQN is to be concealed, in addition the HLR/AuC computes an anonymity key  $AK = f5_K(RAND)$  and computes the concealed sequence number  $SQN \oplus AK = SQN \text{ xor } AK$ . Concealment of the sequence number is optional.
- Finally, the HLR/AuC assembles the authentication token  $AUTN = SQN [\oplus AK] \parallel AMF \parallel MAC-A$  and the quintet  $Q = (RAND, XRES, CK, IK, AUTN)$ .

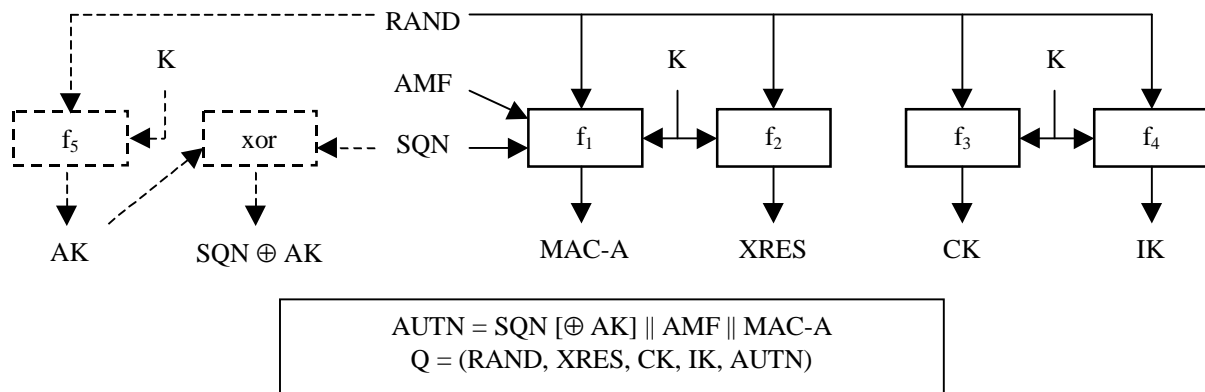

Figure 1: Generation of quintets in the AuC

5.1.1.2 Authentication and key derivation in the USIM

Upon receipt of a (RAND, AUTN) pair the USIM acts as follows:

- If the sequence number is concealed, the USIM computes the anonymity key  $AK = f_{5K}(RAND)$  and retrieves the unconcealed sequence number  $SQN = (SQN \oplus AK) \text{ xor } AK$ .

The USIM computes  $XMAC-A = f_{1K}(SQN || RAND || AMF)$ , the response  $RES = f_{2K}(RAND)$ , the cipher key  $CK = f_{3K}(RAND)$  and the integrity key  $IK = f_{4K}(RAND)$ .

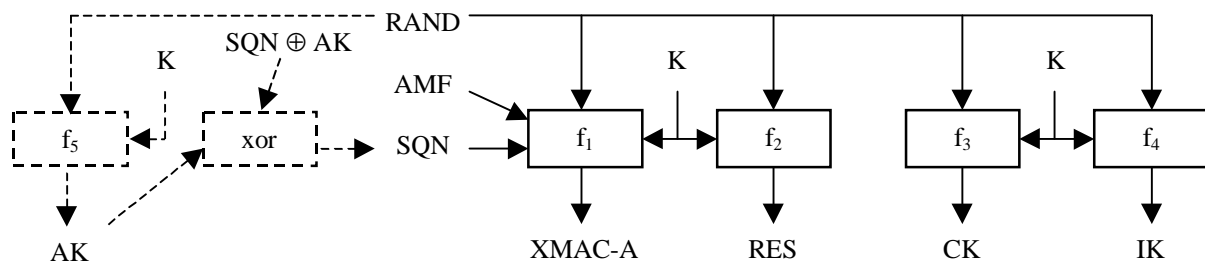

Figure 2: Authentication and key derivation in the USIM

5.1.1.3 Generation of re-synchronisation token in the USIM

Upon the assertion of a synchronisation failure, the USIM generates a re-synchronisation token as follows:

- The USIM computes  $MAC-S = f_{1K}(SQN_{MS} || RAND || AMF^*)$ , whereby  $AMF^*$  is a default value for AMF used in re-synchronisation.
- If  $SQN_{MS}$  is to be concealed with an anonymity key AK, the USIM computes  $AK = f_{5K}(RAND)$ , and the concealed counter value is then computed as  $SQN_{MS} \oplus AK$ .
- The re-synchronisation token is constructed as  $AUTS = SQN_{MS} [\oplus AK] || MAC-S$ .

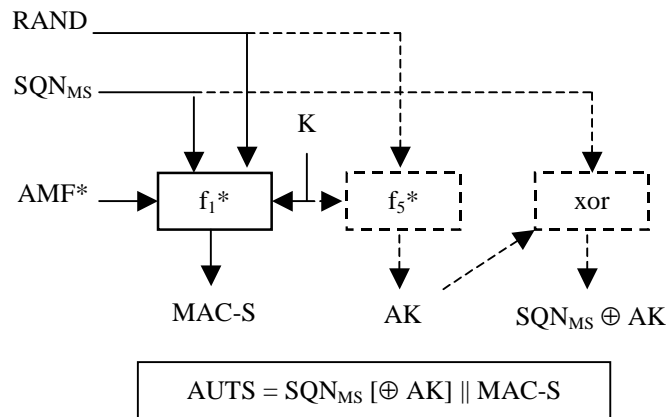

Figure 3: Generation of re-synchronisation token in the USIM

### 5.1.1.4 Re-synchronisation in the HLR/AuC

Upon receipt of an indication of synchronisation failure and a (AUTS, RAND) pair, the HLR/AuC may perform the following cryptographic functions:

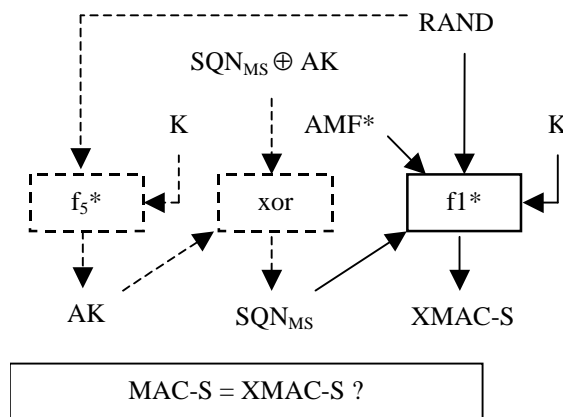

Figure 4: Re-synchronisation in the HLR/AuC

- a) If  $SQN_{MS}$  is concealed with an anonymity key  $AK$ , the HLR/AuC computes  $AK = f5^*_K(RAND)$  and retrieves the unconcealed counter value as  $SQN_{MS} = (SQN_{MS} \oplus AK) \text{ xor } AK$ .
- b) If  $SQN$  generated from  $SQN_{HE}$  would not be acceptable, then the HLR/AuC computes  $XMAC-S = f1^*_K(SQN_{MS} || RAND || AMF^*)$ , whereby  $AMF^*$  is a default value for  $AMF$  used in re-synchronisation.

### 5.1.2 Use

The functions  $f0$ — $f5$  shall only be used to provide mutual entity authentication between USIM and AuC, derive keys to protect user and signalling data transmitted over the radio access link and conceal the sequence number to protect user identity confidentiality. The function  $f1^*$  shall only be used to provide data origin authentication for the synchronisation failure information sent by the USIM to the AuC. The function  $f5^*$  shall only be used to provide user identity confidentiality during re-synchronisation.

### 5.1.3 Allocation

The functions  $f1$ — $f5$ ,  $f1^*$  and  $f5^*$  are allocated to the Authentication Centre (AuC) and the USIM. The function  $f0$  is allocated to the AuC.

### 5.1.4 Extent of standardisation

The functions  $f0$ — $f5$ ,  $f1^*$  and  $f5^*$  are proprietary to the home environment. Examples of the functions  $f1$ ,  $f1^*$  and  $f2$  are CBC-MACs or H-MACs [3].

## 5.1.5 Implementation and operational considerations

The functions  $f1$ — $f5$ ,  $f1^*$  and  $f5^*$  shall be designed so that they can be implemented on an IC card equipped with a 8-bit microprocessor running at 3 MHz with 8 kbyte ROM and 300byte RAM and produce AK, XMAC-A, RES, CK and IK in less than 500 ms execution time.

### 5.1.6 Type of algorithm

#### 5.1.6.1 $f0$

$f0$ : the random challenge generating function

$f0$ : (internal state)  $\rightarrow$  RAND

$f0$  should be (pseudo) random number generating function.

#### 5.1.6.2 $f1$

$f1$ : the network authentication function

$f1$ : (K; SQN, RAND, AMF)  $\rightarrow$  MAC-A (or XMAC-A)

$f1$  should be a MAC function. In particular, it shall be computationally infeasible to derive K from knowledge of RAND, SQN, AMF and MAC-A (or XMAC-A).

#### 5.1.6.3 $f1^*$

$f1^*$ : the re-synchronisation message authentication function

$f1^*$ : (K; SQN, RAND, AMF)  $\rightarrow$  MAC-S (or XMAC-S)

$f1$  should be a MAC function. In particular, it shall be computationally infeasible to derive K from knowledge of RAND, SQN, AMF and MAC-S (or XMAC-S).

#### 5.1.6.4 $f2$

$f2$ : the user authentication function

$f2$ : (K; RAND)  $\rightarrow$  RES (or XRES)

$f2$  should be a MAC function. In particular, it shall be computationally infeasible to derive K from knowledge of RAND and RES (or XRES).

#### 5.1.6.5 $f3$

$f3$ : the cipher key derivation function

$f3$ : (K; RAND)  $\rightarrow$  CK

$f3$  should be a key derivation function. In particular, it shall be computationally infeasible to derive K from knowledge of RAND and CK.

#### 5.1.6.6 $f4$

$f4$ : the integrity key derivation function

$f4$ : (K; RAND)  $\rightarrow$  IK

$f4$  should be a key derivation function. In particular, it shall be computationally infeasible to derive K from knowledge of RAND and IK.

#### 5.1.6.7 $f5$

$f5$ : the anonymity key derivation function for normal operation

$f5$ : (K; RAND)  $\rightarrow$  AK

f5 should be a key derivation function. In particular, it shall be computationally infeasible to derive K from knowledge of RAND and AK.

The use of f5 is optional.

#### 5.1.6.8 f5\*

f5\*: the anonymity key derivation function for re-synchronisation

f5\*: (K; RAND)  $\rightarrow$  AK

f5\* should be a key derivation function. In particular, it shall be computationally infeasible to derive K from knowledge of RAND and AK.

The use of f5\* is optional.

### 5.1.7 Interface

#### 5.1.7.1 K

K: the subscriber authentication key

K[0], K[1], ..., K[127]

The length of K is 128 bits. The subscriber authentication key K is a long term secret key stored in the USIM and the AuC.

#### 5.1.7.2 RAND

RAND: the random challenge

RAND[0], RAND[1], ..., RAND[127]

The length of RAND is 128 bits.

#### 5.1.7.3 SQN

SQN: the sequence number

SQN[0], SQN[1], ..., SQN[47]

The length of SQN is 48 bits. The AuC should include a fresh sequence number in each authentication token. The verification of the freshness of the sequence number by the USIM constitutes to entity authentication of the network to the user.

#### 5.1.7.4 AMF

AMF: the authentication management field

AMF[0], AMF[1], ..., AMF[15]

The length of AMF is 16 bits. The use of AMF is not standardised. Example uses of the AMF are provided in annex F of TS 33.102.

#### 5.1.7.6 MAC-A (equivalent for XMAC-A)

MAC-A: the message authentication code used for authentication of the network to the user

MAC-A[0], MAC-A[1], ..., MAC-A[63]

The length of MAC-A is 64 bits. MAC-A authenticates the data integrity and the data origin of RAND, SQN and AMF. The verification of MAC-A by the USIM constitutes to entity authentication of the network to the user.

### 5.1.7.7 MAC-S (equivalent for XMAC-S)

MAC-S: the message authentication code used to provide data origin authentication for the synchronisation failure information sent by the USIM to the AuC.

MAC-S[0], MAC-S[1], ..., MAC-S[63]

The length of MAC-S is 64 bits. MAC-S authenticates the data integrity and the data origin of RAND, SQN and AMF. MAC-S is generated by the USIM and verified by the AuC.

### 5.1.7.8 RES (or XRES)

RES: the user response

RES[0], RES[1], ..., RES[n-1]

The length n of RES and XRES is at most 128 bits and at least 32 bits, and shall be a multiple of 8 bits. RES and XRES constitute to entity authentication of the user to the network.

### 5.1.7.9 CK

CK: the cipher key

CK[0], CK[1], ..., CK[127]

The length of CK is 128 bits. In case the effective key length should need to be made smaller than 128 bits, the most significant bits of CK shall carry the effective key information, whereas the remaining, least significant bits shall be set zero.

### 5.1.7.10 IK

IK: the integrity key

IK[0], IK[1], ..., IK[127]

The length of IK is 128 bits. In case the effective key length should need to be made smaller than 128 bits, the most significant bits of IK shall carry the effective key information, whereas the remaining, least significant bits shall be set zero.

### 5.1.7.11 AK

AK: the anonymity key

AK[0], AK[1], ..., AK[47]

The length of AK is 48 bits. It equals the length of SQN.

## 5.2 Data confidentiality

### 5.2.1 Overview

The mechanism for data confidentiality of user data and signalling data that is described in 6.6 of [1] requires the following cryptographic function:

f8 UMTS encryption algorithm.

Figure 5 illustrates the use of f8 to encrypt plaintext by applying a keystream using a bitwise XOR operation. The plaintext may be recovered by generating the same keystream using the same input parameters and applying it to the ciphertext using a bitwise XOR operation.

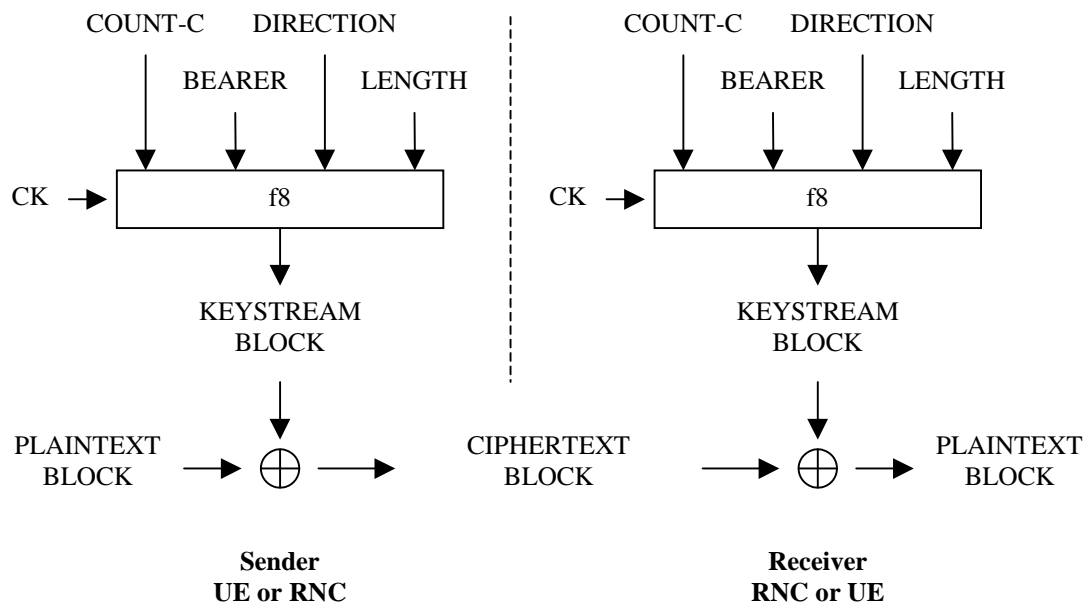

**Figure 5: Ciphering user and signalling data transmitted over the radio access link**

The input parameters to the algorithm are the Cipher Key (CK), a time dependent input (COUNT-C), the bearer identity (BEARER), the direction of transmission (DIRECTION) and the length of the keystream required (LENGTH). Based on these input parameters the algorithm generates the output keystream block (KEYSTREAM) which is used to encrypt the input plaintext block (PLAINTEXT) to produce the output ciphertext block (CIPHERTEXT).

The input parameter LENGTH shall affect only the length of the KEYSTREAM BLOCK, not the actual bits in it.

## 5.2.2 Use

The function f8 shall only be used to protect the confidentiality of user data and signalling data sent over the radio access link between UE and RNC.

## 5.2.3 Allocation

The function f8 is allocated to the UE and the RNC.

Encryption will be applied in the Medium Access Control (MAC) sublayer and in the Radio Link Control (RLC) sublayer of the data link layer (Layer 2).

## 5.2.4 Extent of standardisation

The function f8 shall be fully standardized.

## 5.2.5 Implementation and operational considerations

The algorithm should be designed to accommodate a range of implementation options including hardware and software implementations. For hardware implementations, it should be possible to implement one instance of the algorithm using less than 10,000 gates (working assumption).

A wide range of UE with different bearer capabilities is expected, so the encryption throughput requirements on the algorithm will vary depending on the implementation. However, based on the likely maximum user traffic data rates, it

must be possible to implement the algorithm to achieve an encryption speed in the order of 2Mbit/s on the downlink and on the uplink.

1. RLC-transparent mode:
  - New keystream block required every physical layer frame (10ms)
  - Maximum number of bits per physical layer frame of 20000 bits
  - Minimum number of bits per physical layer frame of 1 bit
  - Granularity of 1 bit on all possible intermediate values.
2. For UM RLC mode:
  - New keystream block required per UMD PDU
  - Maximum number of bits in UMD PDU is 5000 bits
  - Minimum number of bits in UMD PDU is 16 bits
  - Granularity of 8 bit on all possible intermediate values.
3. For AM RLC mode:
  - New keystream block required per AMD PDU
  - Maximum number of bits in AMD PDU is 5000 bits
  - Minimum number of bits in AMD PDU is 24 bits
  - Granularity of 8 bit on all possible intermediate values.

The encryption throughput requirements should be met based on clock speeds upwards of 20MHz (typical clock speeds are expected to be much greater than this).

## 5.2.6 Type of algorithm

The function  $f_8$  should be a symmetric synchronous stream cipher.

## 5.2.7 Interfaces to the algorithm

### 5.2.7.1 CK

CK: the cipher key

$CK[0], CK[1], \dots, CK[127]$

The length of CK is 128 bits. In case the effective key length  $k$  is smaller than 128 bits, the most significant bits of CK shall carry the effective key information, whereas the remaining, least significant bits shall repeat the effective key information:

$CK[n] = CK[n \bmod k]$ , for all  $n$ , such that  $k \leq n < 128$ .

### 5.2.7.2 COUNT-C

COUNT-C: the cipher sequence number.

$COUNT-C[0], COUNT-C[1], \dots, COUNT-C[31]$

The length of the COUNT-C parameter is 32 bits.

Synchronisation of the keystream is based on the use of a physical layer (Layer 1) frame counter combined with a hyperframe counter introduced to avoid re-use of the keystream. This allows the keystream to be synchronised every 10ms physical layer frame. The exact structure of the COUNT-C is specified in TS 33.102.



### 5.2.7.3 BEARER

BEARER: the radio bearer identifier.

BEARER[0], BEARER[1], ..., BEARER[4]

The length of BEARER is 5 bits.

The same cipher key may be used for different radio bearers simultaneously associated with a single user which are multiplexed onto a single 10ms physical layer frame. To avoid using the same keystream to encrypt more than one bearer, the algorithm shall generate the keystream based on the identity of the radio bearer.

### 5.2.7.4 DIRECTION

DIRECTION: the direction of transmission of the bearer to be encrypted.

DIRECTION[0]

The length of DIRECTION is 1 bit.

The same cipher key may be used for uplink and downlink channels simultaneously associated with a UE, which are multiplexed onto a single 10ms physical layer frame. To avoid using the same keystream to encrypt both uplink and downlink transmissions, the algorithm shall generate the keystream based on the direction of transmission.

The value of the DIRECTION is 0 for messages from UE to RNC and 1 for messages from RNC to UE.

An explicit direction value is required in preference to splitting the keystream segment into uplink and downlink portions to allow for asymmetric bearer services.

### 5.2.7.5 LENGTH

LENGTH: the required length of keystream.

LENGTH[0], LENGTH[1], ..., LENGTH[15]

The length of LENGTH is 16 bits.

For a given bearer and transmission direction the length of the plaintext block that is transmitted during a single physical layer frame may vary. The algorithm shall generate a keystream block of variable length based on the value of the length parameter.

The input parameter LENGTH shall affect only the length of the KEYSTREAM BLOCK, not the actual bits in it.

The maximum RLC PDU / MAC SDU size is 5000 bits. The range of values of the length parameter will depend not only on the RLC PDU / MAC SDU size but also the number of RLC PDUs / MAC SDUs which may be sent in a single physical layer 10ms frame for a given bearer and transmission direction.

Not all values between the maximum and minimum values shall be required but it is expected that the ability to produce length values of whole numbers of octets between a minimum and a maximum value will be required.

### 5.2.7.6 KEYSTREAM

KEYSTREAM: the output keystream.

KS [0], KS [1], ..., KS [LENGTH-1]

The length of a keystream block equals the value of the input parameter LENGTH.

### 5.2.7.7 PLAINTEXT

PLAINTEXT: the plaintext.

PT[0], PT[1], ..., PT[LENGTH-1]

The length of a keystream block equals the value of the input parameter LENGTH.

This plaintext block consists of the payload of the particular RLC PDUs / MAC SDUs to be encrypted for a given bearer and transmission direction. It may consist of user traffic or signalling data:

- For RLC UM mode, the plaintext block is the UMD PDU excluding the first octet, i.e. excluding the RLC UM PDU header (see TS 25.322 [19]).
- For RLC AM mode, the plaintext block is the AMD PDU excluding the two first octets, i.e. excluding the RLC AM PDU header (see TS 25.322 [19]).
- For RLC TM on DCH, the plaintext block consists of all the MAC SDUs containing data for one and the same radio bearer and sent in one Transmission Time Interval. In this case, the CFN part of COUNT-C for the plaintext block is the CFN for the first radio frame of the Transmission Time Interval containing the plaintext block. (see TS 25.321 [18]).

### 5.2.7.8 CIPHERTEXT

CIPHERTEXT: the ciphertext.

CT[0], CT[1], ..., CT[LENGTH-1]

The length of a keystream block equals the value of the input parameter LENGTH.

## 5.3 Data integrity

### 5.3.1 Overview

The mechanism for data integrity of signalling data that is described in 6.6 of [1] requires the following cryptographic function:

f9 UMTS integrity algorithm.

Figure 6 illustrates the use of the function f9 to derive a MAC-I from a signalling message.

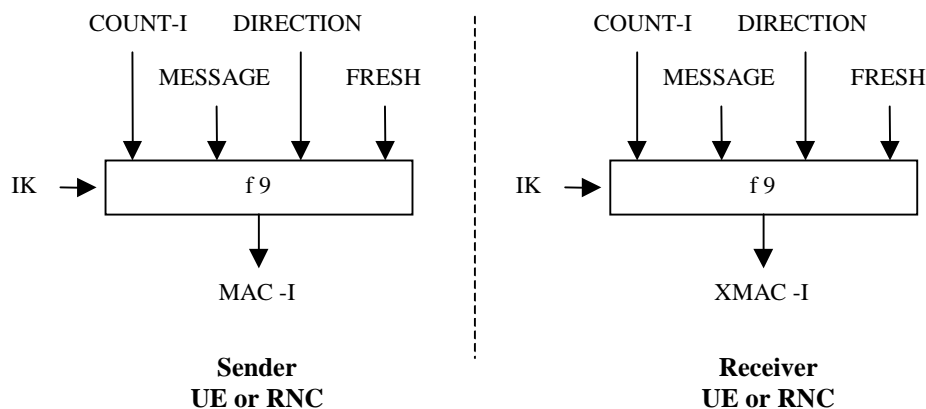

**Figure 6: Derivation of MAC-I (or XMAC-I) on a signalling message**

The input parameters to the algorithm are the Integrity Key (IK), a time dependent input (COUNT-I), a random value generated by the network side (FRESH), the direction bit (DIRECTION) and the signalling data (MESSAGE). Based on these input parameters the user computes with the function f9 the message authentication code for data integrity (MAC-I) which is appended to the message when sent over the radio access link. The receiver computes XMAC-I on the messages received in the same way as the sender computed MAC-I on the message sent.

### 5.3.2 Use

The MAC function f9 shall be used to authenticate the data integrity and data origin of signalling data transmitted between UE and RNC.

### 5.3.3 Allocation

The MAC function f9 is allocated to the UE and the RNC.

Integrity protection shall be applied at the RRC layer.

### 5.3.4 Extent of standardisation

The function f9 is fully standardized.

### 5.3.5 Implementation and operational considerations

The algorithm should be designed to accommodate a range of implementation options including hardware and software implementations.

### 5.3.6 Type of algorithm

The function f9 shall be a MAC function.

### 5.3.7 Interface

#### 5.3.7.1 IK

IK: the integrity key

IK[0], IK[1], ..., IK[127]

The length of IK is 128 bits.

#### 5.3.7.2 COUNT-I

COUNT-I: a frame dependent input.

COUNT-I[0], COUNT-I[1], ..., COUNT-I[31]

The length of COUNT-I is 32 bits.

The input parameter COUNT-I protects against replay during a connection. It is a value incremented by one for each integrity protected message. COUNT-I consists of two parts: the HYPERFRAME NUMBER (HFN) as the most significant part and a RRC Sequence Number as the least significant part. The initial value of the hyperframe number is sent by the user to the network at connection set-up. The user stores the greatest used hyperframe number from the previous connection and increments it by one. In this way the user is assured that no COUNT-I value is re-used (by the network) with the same integrity key.

#### 5.3.7.3 FRESH

FRESH: a random number generated by the RNC.

FRESH[0], FRESH[1], ..., FRESH[31]

The length of FRESH is 32 bits.

The same integrity key may be used for several consecutive connections. This FRESH value is an input to the algorithm in order to assure the network side that the user is not replaying old MAC-Is.

#### 5.3.7.4 MESSAGE

MESSAGE: the signalling data.

MESSAGE[0], MESSAGE[1], ..., MESSAGE[X-1]

The length of MESSAGE is X.

### 5.3.7.5 DIRECTION

DIRECTION: the direction of transmission of signalling messages (user to network or network to users).

DIRECTION[0]

The length of DIRECTION is 1 bit.

The same integrity key may be used for uplink and downlink channels simultaneously associated with a UE.

The value of the DIRECTION is 0 for messages from UE to RNC and 1 for messages from RNC to UE.

### 5.3.7.6 MAC-I (and equivalently XMAC-I)

MAC-I: the message authentication code for data integrity authentication

MAC-I[0], MAC-I[1], ..., MAC-I[31]

The length of MAC-I is 32 bits.

---

## 6 Use of the algorithm specifications

The purpose of this clause is to address ownership of the algorithm specification, to define which types of organisation are entitled to use the algorithm specification, and to outline how and under what conditions such organisations may obtain the specification.

### 6.1 Ownership

For those functions which require to be fully standardized, all copyright on the algorithm and test data specifications shall be owned jointly by the 3GPP partner organisations.

### 6.2 Design authority

The design authority for the algorithms that require standardisation shall be ETSI SAGE. It is expected that the project team assembled by SAGE will draw on appropriate expertise within the 3GPP partner organisations in addition to its normal resource pool.

### 6.3 Users of the specification

For those functions which require to be fully standardized, the algorithm specification shall be published as a 3GPP specification. It will be used by those who need the algorithm specification to build equipments or components which embody the algorithm.

### 6.4 Licensing

For those functions which require to be fully standardized, the use of the algorithm shall be subject to a license agreement which restricts the use of the algorithm as described in 5.3.2 and 5.4.2.

Users of the algorithm, and users of the algorithm specification, shall be required to sign the licence agreement. Appropriate licence agreements shall be drawn up by the 3GPP partner organisations.

Licences shall be royalty free. In addition, the licence agreement shall require users of the specification not to attempt to patent the algorithm or otherwise register an Intellectual Property Right (IPR) relating to the algorithm or its use.

### 6.5 Management of the specification

For those functions which require to be fully standardized, the algorithm specifications shall be published as a 3GPP specification. The algorithms will thus be open for public evaluation. It is recognised that this will leave the algorithms open to public criticism during the commercial operation of the system. The process of responding to public criticism will need to be handled carefully by an appropriate 3GPP body.

---

## 7 Algorithm specification and test data requirements

For those functions that require standardization, the design authority should provide four separate deliverables: a specification of the algorithm, a set of design conformance test data, a set of algorithm input/output test data and a design and evaluation report. Requirements on the specification and test data deliverables are given in this clause, those on the design and evaluation report in 9.3.

### 7.1 Specification of the algorithm

An unambiguous specification of the algorithm needs to be provided which is suitable for use by implementers of the algorithm.

The specification shall include an annex which provides simulation code for the algorithm written in ANSI C. The specification may also include an annex containing illustrations of functional elements of the algorithm.

### 7.2 Implementors test data

The implementors test data is required to assist implementors of the algorithm in their realisation of the algorithm specification.

This set of test data, as well as including algorithm input and output data, shall include details of the internal state of the algorithm at various stages in its execution. Sufficient detail shall be provided to enable implementors to readily identify the likely location of any errors in their implementation.

Final validation of the implementation shall be performed using the design conformance test data (see subclause 7.3).

### 7.3 Design conformance test data

Design conformance test data is required to allow implementors of the algorithm to validate their implementations, and manufacturers to validate embodiments of the algorithm (e.g. in ASICs or FPGAs).

The test data set shall be presented as input/output test data, allowing the realisation to be tested as a 'black box'. (i.e. the test data shall consist solely of data passed across the interfaces to the algorithm.)

The design conformance test data shall be designed to give a high degree of confidence in the correctness of any implementation of the algorithm. The set of test data shall ensure that all elements of the algorithm are fully exercised.

### 7.4 Format and handling of deliverables

The specification of the algorithm shall be produced on paper, and published as a 3GPP specification.

The algorithm input/output test data shall be produced on paper and on magnetic disc, and published by 3GPP. The document and disc shall be provided to 3GPP partner organisations.

---

## 8 Quality assurance requirements

This clause advises the design authority on measures needed to provide users of the algorithm with confidence that it is fit for purpose, and users of the algorithm specification and test data assurance that appropriate quality control has been exercised in their production.

The measures shall be recorded by the design authority in a design and evaluation report which shall be published as a 3GPP specification.

### 8.1 Quality assurance for the algorithm

Prior to its release to 3GPP, the algorithm needs to be approved as meeting the functional requirements specified in clause 7 by all members of the design authority.

## 8.2 Quality assurance for the specification and test data

Prior to delivery of the algorithm specification, two independent simulations of the algorithm needs to be made using the specification, and confirmed against test data designed to allow verification of significant points in the execution of the algorithm.

Design conformance and algorithm input/output test data needs to be generated using a simulation of the algorithm produced from the specification and confirmed as above. The simulation used to produce this test data needs to be identified in the test data deliverables and retained by the design authority.

## 8.3 Design and evaluation report

The design and evaluation report is intended to provide evidence to potential users of the algorithm, specification and test data that appropriate and adequate quality control has been applied to their production. The report shall explain the following:

- the algorithm and test data design criteria;
- the algorithm evaluation criteria;
- the methodology used to design and evaluate the algorithm;
- the extent of the mathematical analysis and statistical testing applied to the algorithm;
- the principal conclusions of the algorithm evaluation;
- the quality control applied to the production of the algorithm specification and test data.

The report shall confirm that all members of the design authority have approved the algorithm, specification and test data.

The report shall contain key conclusions from the commissioned closed evaluation of the algorithm.

---

# 9 Summary of the design authority deliverables

For those cryptographic functions that require standardisation, the design authority shall deliver:

- Specification of the algorithm;
- Implementors test data;
- Design conformance test data;
- Design and evaluation report.

All these documents shall be delivered to 3GPP for subsequent publication.

## Annex A (informative): Void

Void.

## Annex B (informative): Change history

Change history					
TSG SA #	Version	CR	Tdoc SA	New Version	Subject/Comment
SP-24	4.1.0	021	SP-040371	4.2.0	Correction of inconsistencies in AK computation for re-synchronisation
SP-24	4.2.0	-	-	5.0.0	Creation of Release 5 version from version 4.2.0
SP-24	4.2.0	-	-	6.0.0	Creation of Release 6 version from version 4.2.0
2007-06	6.0.0	-	-	7.0.0	Update to Rel-7 version (MCC)
2008-12	7.0.0	-	-	8.0.0	Update to Rel-8 version (MCC)
2009-12	8.0.0	-	-	9.0.0	Update to Rel-9 version (MCC)
SP-51	9.0.0	-	-	10.0.0	Updated to Release 10
2012-09	-	-	-	<b>11.0.0</b>	Update to Rel-11 version (MCC)
2014-09	-	-	-	<b>12.0.0</b>	Update to Rel-12 version (MCC)
2016-01	-	-	-	<b>13.0.0</b>	Update to Rel-13 version (MCC)
2017-03	-	-	-	<b>14.0.0</b>	Update to Rel-14 version (MCC)

Change history							
Date	Meeting	TDoc	CR	Rev	Cat	Subject/Comment	New version
2018-06	-	-	-	-	-	Update to Rel-15 version (MCC)	<b>15.0.0</b>



---

# History

<b>Document history</b>		
V15.0.0	July 2018	Publication