

ETSI TS 133 127 V17.6.0 (2022-09)



**Digital cellular telecommunications system (Phase 2+) (GSM);  
Universal Mobile Telecommunications System (UMTS);  
LTE;  
5G;  
Lawful Interception (LI) architecture and functions  
(3GPP TS 33.127 version 17.6.0 Release 17)**



---

**Reference**

RTS/TSGS-0333127vh60

---

**Keywords**

5G,GSM,LTE,SECURITY,UMTS

**ETSI**

650 Route des Lucioles  
F-06921 Sophia Antipolis Cedex - FRANCE

Tel.: +33 4 92 94 42 00 Fax: +33 4 93 65 47 16

Siret N° 348 623 562 00017 - APE 7112B  
Association à but non lucratif enregistrée à la  
Sous-Préfecture de Grasse (06) N° w061004871

---

**Important notice**

The present document can be downloaded from:

<http://www.etsi.org/standards-search>

The present document may be made available in electronic versions and/or in print. The content of any electronic and/or print versions of the present document shall not be modified without the prior written authorization of ETSI. In case of any existing or perceived difference in contents between such versions and/or in print, the prevailing version of an ETSI deliverable is the one made publicly available in PDF format at [www.etsi.org/deliver](http://www.etsi.org/deliver).

Users of the present document should be aware that the document may be subject to revision or change of status.

Information on the current status of this and other ETSI documents is available at

<https://portal.etsi.org/TB/ETSIDeliverableStatus.aspx>

If you find errors in the present document, please send your comment to one of the following services:

<https://portal.etsi.org/People/CommitteeSupportStaff.aspx>

If you find a security vulnerability in the present document, please report it through our  
Coordinated Vulnerability Disclosure Program:

<https://www.etsi.org/standards/coordinated-vulnerability-disclosure>

---

**Notice of disclaimer & limitation of liability**

The information provided in the present deliverable is directed solely to professionals who have the appropriate degree of experience to understand and interpret its content in accordance with generally accepted engineering or other professional standard and applicable regulations.

No recommendation as to products and services or vendors is made or should be implied.

No representation or warranty is made that this deliverable is technically accurate or sufficient or conforms to any law and/or governmental rule and/or regulation and further, no representation or warranty is made of merchantability or fitness for any particular purpose or against infringement of intellectual property rights.

In no event shall ETSI be held liable for loss of profits or any other incidental or consequential damages.

Any software contained in this deliverable is provided "AS IS" with no warranties, express or implied, including but not limited to, the warranties of merchantability, fitness for a particular purpose and non-infringement of intellectual property rights and ETSI shall not be held liable in any event for any damages whatsoever (including, without limitation, damages for loss of profits, business interruption, loss of information, or any other pecuniary loss) arising out of or related to the use of or inability to use the software.

---

**Copyright Notification**

No part may be reproduced or utilized in any form or by any means, electronic or mechanical, including photocopying and microfilm except as authorized by written permission of ETSI.

The content of the PDF version shall not be modified without the written authorization of ETSI.

The copyright and the foregoing restriction extend to reproduction in all media.

© ETSI 2022.  
All rights reserved.

---

# Intellectual Property Rights

## Essential patents

IPRs essential or potentially essential to normative deliverables may have been declared to ETSI. The declarations pertaining to these essential IPRs, if any, are publicly available for **ETSI members and non-members**, and can be found in ETSI SR 000 314: "*Intellectual Property Rights (IPRs); Essential, or potentially Essential, IPRs notified to ETSI in respect of ETSI standards*", which is available from the ETSI Secretariat. Latest updates are available on the ETSI Web server (<https://ipr.etsi.org/>).

Pursuant to the ETSI Directives including the ETSI IPR Policy, no investigation regarding the essentiality of IPRs, including IPR searches, has been carried out by ETSI. No guarantee can be given as to the existence of other IPRs not referenced in ETSI SR 000 314 (or the updates on the ETSI Web server) which are, or may be, or may become, essential to the present document.

## Trademarks

The present document may include trademarks and/or tradenames which are asserted and/or registered by their owners. ETSI claims no ownership of these except for any which are indicated as being the property of ETSI, and conveys no right to use or reproduce any trademark and/or tradename. Mention of those trademarks in the present document does not constitute an endorsement by ETSI of products, services or organizations associated with those trademarks.

**DECT™**, **PLUGTESTS™**, **UMTS™** and the ETSI logo are trademarks of ETSI registered for the benefit of its Members. **3GPP™** and **LTE™** are trademarks of ETSI registered for the benefit of its Members and of the 3GPP Organizational Partners. **oneM2M™** logo is a trademark of ETSI registered for the benefit of its Members and of the oneM2M Partners. **GSM®** and the GSM logo are trademarks registered and owned by the GSM Association.

---

# Legal Notice

This Technical Specification (TS) has been produced by ETSI 3rd Generation Partnership Project (3GPP).

The present document may refer to technical specifications or reports using their 3GPP identities. These shall be interpreted as being references to the corresponding ETSI deliverables.

The cross reference between 3GPP and ETSI identities can be found under <http://webapp.etsi.org/key/queryform.asp>.

---

# Modal verbs terminology

In the present document "**shall**", "**shall not**", "**should**", "**should not**", "**may**", "**need not**", "**will**", "**will not**", "**can**" and "**cannot**" are to be interpreted as described in clause 3.2 of the [ETSI Drafting Rules](#) (Verbal forms for the expression of provisions).

"**must**" and "**must not**" are **NOT** allowed in ETSI deliverables except when used in direct citation.

# Contents

Intellectual Property Rights .....	2
Legal Notice .....	2
Modal verbs terminology.....	2
Foreword.....	11
Introduction .....	11
1 Scope .....	12
2 References .....	12
3 Definitions, symbols and abbreviations .....	14
3.1 Definitions .....	14
3.2 Symbols.....	15
3.3 Abbreviations .....	15
4 Requirements realisation .....	17
5 Functional architecture .....	17
5.1 General .....	17
5.2 High-level generic LI architecture.....	18
5.3 Functional entities .....	19
5.3.1 Law Enforcement Agency (LEA).....	19
5.3.2 Point of Interception (POI) .....	19
5.3.2.1 General .....	19
5.3.2.2 Directly provisioned and triggered POIs.....	19
5.3.2.3 IRI-POIs and CC-POIs.....	19
5.3.2.4 Failure handling .....	19
5.3.3 Triggering Function .....	19
5.3.4 Mediation and Delivery Function (MDF).....	20
5.3.5 Administration Function (ADMF).....	20
5.3.5.1 General .....	20
5.3.5.2 LICF .....	21
5.3.5.3 LIPF .....	21
5.3.5.4 IQF .....	22
5.3.5.5 LI Function Selection.....	22
5.3.6 System Information Retrieval Function (SIRF).....	22
5.3.7 LEMF – Law Enforcement Monitoring Facility .....	23
5.4 LI interfaces.....	23
5.4.1 General.....	23
5.4.2 Interface LI_SI.....	24
5.4.3 Interface LI_HI1 .....	24
5.4.4 Interface LI_X1 .....	25
5.4.4.1 General .....	25
5.4.4.2 LIPF and POI .....	25
5.4.4.3 LIPF and TF .....	25
5.4.4.4 LIPF and MDF2/MDF3 .....	25
5.4.5 Interface LI_X2 .....	26
5.4.6 Interface LI_X3 .....	26
5.4.7 Interface LI_T .....	26
5.4.7.1 General .....	26
5.4.7.2 Interface LI_T2 .....	26
5.4.7.3 Interface LI_T3 .....	27
5.4.8 Interface LI_HI2 .....	27
5.4.9 Interface LI_HI3 .....	27
5.4.10 Interface LI_HI4 .....	27
5.4.10.1 General .....	27
5.4.10.2 LI operation notification .....	27

5.4.10.3	Contents of the notification .....	27
5.4.11	Interface LI_ADMF .....	28
5.4.12	Interface LI_MDF .....	28
5.4.13	Interface LI_IQF .....	28
5.4.14	Interface LI_XQR .....	28
5.4.15	Interface LI_HIQR .....	28
5.4.16	Interface LI_XER .....	29
5.4.17	Interface LI_XEM1 .....	29
5.5	LI service discovery .....	29
5.6	LI in a virtualised environment .....	30
5.6.1	General .....	30
5.6.2	Virtualised deployment architecture .....	30
5.6.3	LI function instantiation and lifecycle management procedures .....	32
5.6.3.1	Controller virtualisation layer and MANO procedures .....	32
5.6.3.1.1	Responsibilities .....	32
5.6.3.1.2	General procedures .....	32
5.6.3.1.3	Instantiation .....	32
5.6.3.1.4	Modification .....	33
5.6.3.1.5	Termination .....	33
5.6.3.1.6	Direct instantiation of LI Functions by ADMF .....	33
5.6.3.2	LI_X0 procedures .....	33
5.6.3.3	Exception Procedures .....	35
5.7	Identifier association and reporting .....	36
5.7.1	General .....	36
5.7.2	Functional entities .....	37
5.7.2.1	Identity Query Function (IQF) .....	37
5.7.2.2	Identity Event Function (IEF) .....	38
5.7.2.3	Identity Caching Function (ICF) .....	38
6	Network layer based interception .....	39
6.1	General .....	39
6.2	5G .....	39
6.2.1	General .....	39
6.2.2	LI at AMF .....	40
6.2.2.1	Architecture .....	40
6.2.2.2	Target identities .....	41
6.2.2.3	Identity privacy .....	42
6.2.2.4	IRI events .....	42
6.2.2.5	Common IRI parameters .....	43
6.2.2.6	Specific IRI parameters .....	43
6.2.2.7	Network topologies .....	44
6.2.2A	Identifier Reporting for AMF .....	44
6.2.2A.1	General .....	44
6.2.2A.2	IEF Events .....	44
6.2.2A.3	IEF Event parameters .....	44
6.2.2A.4	Network topologies .....	45
6.2.3	LI for SMF/UPF .....	45
6.2.3.1	Architecture .....	45
6.2.3.2	Target identities .....	47
6.2.3.3	IRI events .....	47
6.2.3.4	Common IRI parameters .....	48
6.2.3.5	Specific IRI parameters .....	48
6.2.3.6	Network topologies .....	48
6.2.3.7	Multi-Access PDU (MA PDU) Session Specific .....	49
6.2.3.8	LI state transfers in SMF sets .....	50
6.2.3.9	Interface LI_ST .....	51
6.2.4	LI at UDM for 5G .....	51
6.2.5	LI at SMSF .....	51
6.2.5.1	Architecture .....	51
6.2.5.2	Target identities .....	52
6.2.5.3	IRI events .....	53
6.2.5.4	Common IRI parameters .....	53

6.2.5.5	Specific IRI parameters.....	53
6.2.5.6	Network topologies.....	53
6.2.6	LI support at NRF.....	53
6.2.6.1	Architecture.....	53
6.2.6.2	LI_SI notifications.....	54
6.2.6.3	LI_SI parameters.....	54
6.2.7	External data storage.....	55
6.2.7.1	UDSF or UDR.....	55
6.2.7.2	LI State Storage Function (LISSF).....	55
6.3	EPC.....	55
6.3.1	General.....	55
6.3.2	LI at the MME.....	56
6.3.2.1	Architecture.....	56
6.3.2.2	Target identities.....	57
6.3.2.3	IRI events.....	57
6.3.2.3.1	Option A.....	57
6.3.2.3.2	Option B.....	58
6.3.2.4	Common IRI parameters.....	58
6.3.2.5	Specific IRI parameters.....	58
6.3.2.5.1	Option A.....	58
6.3.2.5.2	Option B.....	59
6.3.2.6	Network topologies.....	59
6.3.3	LI at SGW/PGW.....	60
6.3.3.1	Architecture.....	60
6.3.3.1.1	General.....	60
6.3.3.1.2	Non-CUPS architecture.....	61
6.3.3.1.3	EPS CUPS Architecture.....	62
6.3.3.2	Target identities.....	63
6.3.3.3	IRI events.....	64
6.3.3.3.1	Option A.....	64
6.3.3.3.2	Option B.....	65
6.3.3.4	Common IRI parameters.....	65
6.3.3.5	Specific IRI parameters.....	65
6.3.3.6	Network topologies.....	65
6.3.3.6.1	Network topologies without EPC/5GC interworking.....	65
6.3.3.6.2	Network topologies with EPC/5GC interworking.....	65
6.3.3.7	EPC-5GC Interworking via SMF+PGW-C and UPF+PGW-U.....	66
6.3.4	LI at ePDG.....	66
6.3.4.1	Architecture.....	66
6.3.4.2	Target identities.....	68
6.3.4.3	IRI events.....	68
6.3.4.4	Common IRI parameters.....	68
6.3.4.5	Specific IRI parameters.....	68
6.3.4.6	Network topologies.....	68
6.4	3G.....	68
6.5	VoNR.....	68
6.6	4G/5G Interworking.....	69
7	Service layer based interception.....	69
7.1	General.....	69
7.2	Central subscriber management.....	69
7.2.1	General.....	69
7.2.2	LI at UDM.....	70
7.2.2.1	Architecture.....	70
7.2.2.2	Target identities.....	71
7.2.2.3	Identity privacy.....	71
7.2.2.4	IRI events.....	71
7.2.2.5	Common IRI parameters.....	72
7.2.2.6	Specific IRI parameters.....	72
7.2.2.7	Network topologies.....	72
7.2.3	LI at HSS.....	72
7.2.3.1	Architecture.....	72

7.2.3.2	Target identities.....	73
7.2.3.3	IRI events .....	74
7.2.3.4	Common IRI parameters .....	74
7.2.3.5	Specific IRI parameters.....	74
7.2.3.6	Network topologies .....	74
7.3	Location.....	74
7.3.1	General.....	74
7.3.2	Service usage location reporting .....	74
7.3.2.1	General .....	74
7.3.2.2	Embedded location reporting .....	74
7.3.2.3	Separated location reporting.....	75
7.3.3	Lawful Access Location Services (LALS) .....	75
7.3.3.1	General .....	75
7.3.3.2	Target positioning .....	76
7.3.3.2.1	General .....	76
7.3.3.2.2	Immediate location provision .....	76
7.3.3.2.3	Periodic location provision.....	77
7.3.3.3	Triggered location .....	77
7.3.3.4	LI_X2 interface for target positioning and triggered location.....	78
7.3.4	Cell database information reporting.....	78
7.4	IMS.....	79
7.4.1	General.....	79
7.4.2	Architecture .....	80
7.4.2.1	Overview .....	80
7.4.2.2	Target identities.....	81
7.4.2.3	Target identification .....	82
7.4.3	IRI-POI .....	82
7.4.3.1	General .....	82
7.4.3.2	IRI events .....	82
7.4.3.3	Common IRI parameters .....	83
7.4.3.4	Specific IRI parameters.....	83
7.4.4	CC-TF and CC-POI .....	83
7.4.4.1	General .....	83
7.4.4.2	CC intercept trigger.....	83
7.4.4.3	Common CC parameters .....	84
7.4.5	Correlation of xCC and xIRI.....	84
7.4.6	Network topologies.....	84
7.4.6.1	General.....	84
7.4.6.2	IMS Network Functions providing the IRI-POI.....	85
7.4.6.3	IMS Network Functions providing the CC-TF and CC-POI functions .....	87
7.4.7	Roaming cases .....	88
7.4.7.1	Media unavailable in a roaming case .....	88
7.4.7.2	S8HR.....	88
7.4.7.2.1	Background .....	88
7.4.7.2.2	LI architecture .....	89
7.4.7.2.3	S8HR LI Process .....	89
7.4.7.2.4	CC intercept trigger .....	89
7.4.7.2.5	S8HR LI and Target UE Mobility .....	90
7.4.7.3	N9HR .....	90
7.4.7.3.1	Background .....	90
7.4.7.3.2	LI architecture .....	90
7.4.7.3.3	N9HR LI Process.....	90
7.4.7.3.4	CC intercept trigger .....	91
7.4.7.3.5	N9HR LI and Target UE Mobility.....	91
7.4.7.4	LI in VPLMN with home-routed roaming architecture.....	91
7.4.7.4.1	Background .....	91
7.4.7.4.2	LI architecture .....	92
7.4.7.4.3	Target identifiers .....	92
7.4.7.4.4	Target identification .....	92
7.4.7.4.5	IRI events .....	92
7.4.7.4.6	IRI parameters .....	92
7.4.7.4.7	CC intercept trigger .....	93

7.4.7.4.8	CC parameters .....	93
7.4.7.4.9	Correlation of xCC and xIRI .....	93
7.4.7.4.10	LI specific functions and interfaces .....	93
7.4.7.4.11	LI Process .....	94
7.4.7.4.12	Target UE Mobility .....	95
7.5	MMS .....	95
7.5.1	Overview .....	95
7.5.2	LI at MMS Proxy-Relay .....	95
7.5.2.1	Architecture .....	95
7.5.2.2	Target Identities .....	95
7.5.2.3	IRI Events .....	96
7.5.2.4	Common IRI parameters .....	96
7.5.2.5	Specific IRI parameters .....	96
7.5.2.6	CC .....	96
7.5.2.7	Network Topologies .....	96
7.6	PTC service .....	96
7.6.1	General .....	96
7.6.2	Target identities .....	97
7.6.3	IRI events .....	97
7.6.4	Common IRI parameters .....	98
7.6.5	Specific IRI parameters .....	98
7.6.6	Common CC parameters .....	98
7.6.7	Specific CC parameters .....	98
7.6.8	Network topologies .....	98
7.7	Identity Caching Function .....	98
7.7.1	General .....	98
7.7.2	ICF Query Identities .....	98
7.7.3	ICF Response parameters .....	99
7.7.4	Network topologies .....	99
7.8	Non-IP data delivery (NIDD) in 5GS .....	99
7.8.1	Background .....	99
7.8.1.1	General .....	99
7.8.1.2	NIDD in non-roaming situation .....	100
7.8.1.2.1	Delivery using NEF .....	100
7.8.1.2.2	Delivery using UPF via a PtP N6 tunnel .....	100
7.8.1.3	NIDD in roaming situation .....	100
7.8.1.3.1	Delivery using NEF .....	100
7.8.1.3.2	Delivery using UPF via a PtP N6 tunnel .....	101
7.8.2	LI for NIDD .....	101
7.8.2.1	LI for NIDD using NEF .....	101
7.8.2.1.1	General .....	101
7.8.2.1.2	Architecture for NIDD using NEF in the VPLMN .....	101
7.8.2.1.3	Target identifiers .....	102
7.8.2.1.4	IRI events .....	102
7.8.2.2	LI for NIDD using a PtP N6 tunnel .....	103
7.9	LI at NEF .....	103
7.9.1	General .....	103
7.9.2	LI for NIDD using NEF .....	103
7.9.2.1	Architecture .....	103
7.9.2.2	Target Identities .....	104
7.9.2.3	IRI events .....	104
7.9.3	LI for device triggering .....	105
7.9.3.1	Background .....	105
7.9.3.2	Architecture .....	105
7.9.3.3	Target identities .....	106
7.9.3.4	IRI events .....	106
7.9.4	LI for MSISDN-less MO SMS .....	106
7.9.4.1	Background .....	106
7.9.4.2	Architecture .....	107
7.9.4.3	Target identities .....	107
7.9.4.4	IRI events .....	107
7.9.5	LI for parameter provisioning .....	107



7.9.5.1	Background .....	107
7.9.5.2	Architecture.....	108
7.9.5.3	Target identities.....	108
7.9.5.4	IRI events .....	108
7.10	Non-IP data delivery (NIDD) in EPS .....	108
7.10.1	Background.....	108
7.10.1.1	General .....	108
7.10.1.2	NIDD in non-roaming situation .....	108
7.10.1.2.1	Delivery using SCEF .....	108
7.10.1.2.2	Delivery using a PtP SGI tunnel .....	109
7.10.1.3	NIDD in roaming situation.....	109
7.10.1.3.1	Delivery using SCEF .....	109
7.10.1.3.2	Delivery using a PtP SGI tunnel .....	109
7.10.2	LI for NIDD.....	110
7.10.2.1	LI for NIDD using SCEF .....	110
7.10.2.2	LI for NIDD using a PtP SGI tunnel .....	110
7.11	LI at SCEF.....	110
7.11.1	General.....	110
7.11.2	LI for NIDD using SCEF.....	111
7.11.2.1	Architecture.....	111
7.11.2.2	Target Identities .....	111
7.11.2.3	IRI events .....	112
7.11.3	LI for device triggering.....	112
7.11.3.1	Background .....	112
7.11.3.2	Architecture.....	113
7.11.3.3	Target identities.....	113
7.11.3.4	IRI events .....	113
7.11.4	LI for MSISDN-less MO SMS .....	114
7.11.4.1	Background .....	114
7.11.4.2	Architecture.....	114
7.11.4.3	Target identities.....	114
7.11.4.4	IRI events .....	114
7.11.5	LI for parameter provisioning.....	114
7.11.5.1	Background .....	114
7.11.5.2	Architecture.....	115
7.11.5.3	Target identities.....	115
7.11.5.4	IRI events .....	115
7.12	Data .....	115
7.12.1	General.....	115
7.12.2	Packet header information reporting.....	115
7.12.2.1	General .....	115
7.12.2.2	Report types .....	115
7.12.2.3	Implementation approaches.....	116
7.13	RCS .....	116
7.13.1	Background.....	116
7.13.2	Architecture .....	117
7.13.2.1	Overview.....	117
7.13.2.2	Deployment options .....	118
7.13.2.2.1	Implementations without a third party registration to the RCS Server .....	118
7.13.2.2.2	Implementations that have a Localisation Function .....	119
7.13.3	Target identities .....	119
7.13.4	IRI events.....	120
7.13.4.1	General RCS IRI events .....	120
7.13.4.2	RCS events for topologies without a third party registration to the RCS Server .....	121
7.13.4.3	RCS events for topologies utilising a Localisation Function .....	122
7.14	STIR/SHAKEN and RCD/eCNAM .....	122
7.14.1	General.....	122
7.14.2	Architecture .....	122
7.14.3	IRI events.....	123
7.15	LI for services encrypted by CSP-provided keys .....	124
7.15.1	Background.....	124
7.15.1.1	General .....	124

7.15.1.2	LI requirements - overview .....	124
7.15.2	Architecture .....	125
7.15.3	LI for specific services.....	126
7.15.3.1	LI for general AKMA-based service.....	126
7.15.3.1.1	Background .....	126
7.15.3.1.2	LI architecture .....	127
7.15.3.1.3	Target identities .....	128
7.15.3.1.3.1	Provisioning .....	128
7.15.3.1.3.2	Triggering .....	128
7.15.3.1.4	IRI events .....	128
7.15.3.1.5	Common IRI parameters .....	129
7.15.3.1.6	Specific IRI parameters .....	129
7.15.3.1.7	Network topologies .....	130
7.15.3.1.8	Provision of CC .....	131
8	LI security and deployment considerations .....	131
8.1	Introduction .....	131
8.2	Architectural alternatives .....	131
8.2.1	Full target list at every POI node .....	131
8.2.2	Full target list only in LICF .....	131
8.2.3	Provisioning for registered users .....	131
8.3	LI key management at ADMF.....	132
8.3.1	General.....	132
8.3.2	Key management .....	132
8.4	Virtualised LI security.....	132
8.4.1	General.....	132
8.4.2	NFVI and host requirements.....	132
8.4.3	Virtualised LI function implementation.....	132
8.4.4	Container based deployments .....	133
8.5	Points of Interception .....	133
8.6	Deployment considerations .....	134
8.6.1	General.....	134
8.6.2	CC-PAG.....	134
<b>Annex A (informative): 5G LI network topology views.....</b>		<b>136</b>
A.1	Non-roaming scenario .....	136
A.1.1	General .....	136
A.1.2	Service-based representation with point-to-point LI system .....	136
A.2	Interworking with EPC/E-UTRAN .....	137
A.2.1	General .....	137
A.2.2	Topology view for a non-roaming scenario .....	138
A.3	Multiple DN connections in a PDU session.....	140
A.3.1	General .....	140
A.3.2	Topology view for a non-roaming scenario .....	140
A.4	Non-3GPP access in a non-roaming scenario .....	142
A.4.1	General .....	142
A.4.2	Topology view.....	143
<b>Annex B (normative): ADMF functionality.....</b>		<b>147</b>
<b>Annex C (informative): LEA initiated suspend and resume .....</b>		<b>148</b>
<b>Annex D (informative): Additional RCS specific LI details .....</b>		<b>149</b>
D.1	General .....	149
D.2	LI for Registration and Deregistration .....	149
D.2.1	Background .....	149
D.2.2	Architecture .....	149
D.3	LI for capability discovery .....	150

D.3.1	Background .....	150
D.3.2	Architecture .....	150
D.4	LI for standalone messaging.....	151
D.4.1	Background .....	151
D.4.2	Architecture .....	151
D.5	LI for chat.....	151
D.5.1	Background .....	151
D.5.2	Architecture.....	151
D.6	LI for file transfer .....	152
D.6.1	Background .....	152
D.6.2	Architecture.....	152
<b>Annex E (informative): STIR/SHAKEN operation.....</b>		<b>153</b>
E.1	General .....	153
E.2	STIR/SHAKEN .....	153
E.2.1	STIR/SHAKEN for telephony.....	153
E.2.2	STIR/SHAKEN for intra-network telephony .....	154
E.2.3	STIR/SHAKEN for messaging.....	154
E.2.4	Out of band SHAKEN.....	155
E.2.5	STIR/SHAKEN and forwarded calls.....	156
E.3	Enhanced caller data.....	156
E.3.1	General .....	156
E.3.2	RCD.....	156
E.3.3	eCNAM .....	156
E.4	STIR/SHAKEN call flow example .....	157
<b>Annex Z (informative): Change history .....</b>		<b>159</b>
History .....		161

---

## Foreword

This Technical Specification has been produced by the 3rd Generation Partnership Project (3GPP).

The contents of the present document are subject to continuing work within the TSG and may change following formal TSG approval. Should the TSG modify the contents of the present document, it will be re-released by the TSG with an identifying change of release date and an increase in version number as follows:

Version x.y.z

where:

- x the first digit:
  - 1 presented to TSG for information;
  - 2 presented to TSG for approval;
  - 3 or greater indicates TSG approved document under change control.
- y the second digit is incremented for all changes of substance, i.e. technical enhancements, corrections, updates, etc.
- z the third digit is incremented when editorial only changes have been incorporated in the document.

---

## Introduction

The present document has been produced by the 3GPP TSG SA to standardise Lawful Interception of telecommunications. The present document specifies the architecture and functions required to support Lawful Interception in 3GPP networks. Lawful Interception shall always be done in accordance with the applicable national or regional laws and technical regulations. Such national laws and regulations define the extent to which functional capabilities in the present document are applicable in specific jurisdictions.

---

# 1 Scope

The present document specifies both the architectural and functional system requirements for Lawful Interception (LI) in 3GPP networks. The present document provides an LI architecture supporting both network layer based and service layer based Interception.

National regulations determine the specific set of LI functional capabilities that are applicable to a specific 3GPP operator deployment.

---

# 2 References

The following documents contain provisions which, through reference in this text, constitute provisions of the present document.

- References are either specific (identified by date of publication, edition number, version number, etc.) or non-specific.
- For a specific reference, subsequent revisions do not apply.
- For a non-specific reference, the latest version applies. In the case of a reference to a 3GPP document (including a GSM document), a non-specific reference implicitly refers to the latest version of that document *in the same Release as the present document*.

- [1] 3GPP TR 21.905: "Vocabulary for 3GPP Specifications".
- [2] 3GPP TS 23.501: "System Architecture for the 5G System".
- [3] 3GPP TS 33.126: "Lawful interception requirements".
- [4] 3GPP TS 23.502: "Procedures for the 5G System; Stage 2".
- [5] 3GPP TS 23.271: "Functional stage 2 description of Location Services (LCS)".
- [6] OMA-TS-MLP-V3\_5-20181211-C: "Open Mobile Alliance; Mobile Location Protocol, Candidate Version 3.5", [https://www.openmobilealliance.org/release/MLS/V1\\_4-20181211-C/OMA-TS-MLP-V3\\_5-20181211-C.pdf](https://www.openmobilealliance.org/release/MLS/V1_4-20181211-C/OMA-TS-MLP-V3_5-20181211-C.pdf).
- [7] ETSI TS 103 120: "Lawful Interception (LI); Interface for warrant information".
- [8] ETSI TS 103 221-1: "Lawful Interception (LI); Internal Network Interfaces; Part 1: X1".
- [9] 3GPP TS 33.501: "Security Architecture and Procedures for the 5G System".
- [10] ETSI GR NFV-SEC 011: "Network Functions Virtualisation (NFV); Security; Report on NFV LI Architecture".
- [11] 3GPP TS 33.107: "3G Security; Lawful interception architecture and functions".
- [12] 3GPP TS 23.214: "Architecture enhancements for control and user plane separation of EPC nodes; Stage 2".
- [13] 3GPP TS 23.228: "IP Multimedia Subsystem (IMS); Stage 2".
- [14] 3GPP TS 38.413: "NG-RAN; NG Application Protocol (NGAP)".
- [15] 3GPP TS 33.128: "Protocol and Procedures for Lawful Interception; Stage 3".
- [16] ETSI TS 103 221-2: " Lawful Interception (LI); Internal Network Interfaces; Part 2: X2/X3".
- [17] MMS Architecture OMA-AD-MMS-V1\_3-20110913-A.
- [18] Multimedia Messaging Service Encapsulation Protocol OMA-TS-MMS\_ENC-V1\_3-20110913-A.
- [19] 3GPP TS 22.140: "Multimedia Messaging Service (MMS); Stage 1".

- [20] ETSI GS NFV-IFA 026: "Network Functions Virtualisation (NFV) Release 3; Management and Orchestration; Architecture enhancement for Security Management Specification".
- [21] 3GPP TS 33.108: "Handover Interface for Lawful Interception (LI)".
- [22] 3GPP TS 23.401: "General Packet Radio Service (GPRS) enhancements for Evolved Universal Terrestrial Radio Access Network (E-UTRAN) access".
- [23] 3GPP TS 23.402: "Architecture enhancements for non-3GPP accesses".
- [24] 3GPP TS 23.280: "Common functional architecture to support mission critical services; Stage 2".
- [25] OMA-AD-PoC-V2\_1-20110802-A: "Push to talk over Cellular (PoC) Architecture".
- [26] GSMA IR.92: "IMS Profile for Voice and SMS".
- [27] GSMA NG.114: "IMS Profile for Voice, Video and Messaging over 5GS".
- [28] 3GPP TS 24.147: "Conferencing using the IP Multimedia (IM) Core Network (CN) subsystem; Stage 3".
- [29] ETSI GS NFV-SEC 012: "Network Functions Virtualisation (NFV) Release 3; Security; System architecture specification for execution of sensitive NFV components".
- [30] 3GPP TS 23.273: "5G System (5GS) Location Services (LCS); Stage 2".
- [31] 3GPP TS 29.522: "5G System; Network Exposure Function Northbound APIs; Stage3".
- [32] 3GPP TS 29.122: "T8 reference point for Northbound APIs".
- [33] 3GPP TS 23.682: "Architecture enhancements to facilitate communications with packet data networks and applications".
- [34] OMA-AD-CPM-V2\_2-20170926-C: "Open Mobile Alliance, OMA Converged IP Messaging System Description", [http://www.openmobilealliance.org/release/CPM/V2\\_2-20200907-C/OMA-AD-CPM-V2\\_2-20170926-C.pdf](http://www.openmobilealliance.org/release/CPM/V2_2-20200907-C/OMA-AD-CPM-V2_2-20170926-C.pdf).
- [35] GSMA RCC.07: "Rich Communication Suite – Advanced Communications Services and Client Specification".
- [36] IETF RFC 4975: "The Message Session Relay Protocol (MSRP)".
- [37] IETF RFC 6714: "Connection Establishment for Media Anchoring (CEMA) for the Message Session Relay Protocol (MSRP)".
- [38] IETF RFC 3862: "Common Presence and Instant Messaging (CPIM): Message Format".
- [39] 3GPP TS 24.229: "IP Multimedia call control protocol based on Session Initiation Protocol (SIP) and Session Description Protocol (SDP); Stage 3".
- [40] IETF RFC 8224: "Authenticated Identity Management in the Session Initiation Protocol (SIP)".
- [41] IETF RFC 8946: "Personal Assertion Token (PASSporT) Extension for Diverted Calls".
- [42] IETF draft-ietf-stir-passport-rcd-12, "PASSporT Extension for Rich Call Data".

NOTE: The above document cannot be formally referenced until it is published as an RFC.

- [43] IETF RFC 7095: "jCard: The JSON Format for vCard".
- [44] 3GPP TS 24.196: "Enhanced Calling Name (eCNAM)".
- [45] IETF RFC 8816: "Secure Telephone Identity Revisited (STIR) Out-of-Band Architecture and Use Cases".
- [46] IETF draft-ietf-stir-passport-messaging-00, "Messaging Use Cases and Extensions for STIR".

NOTE: The above document cannot be formally referenced until it is published as an RFC.

- [47] 3GPP TS 33.535: "Authentication and Key Management for Applications (AKMA) based on 3GPP credentials in the 5G System (5GS)".
- [48] 3GPP TS 33.220: "Generic Authentication Architecture (GAA); Generic Bootstrapping Architecture (GBA)".
- [49] 3GPP TS 33.222: "Generic Authentication Architecture (GAA); Access to network application functions using Hypertext Transfer Protocol over Transport Layer Security (HTTPS)".
- [50] 3GPP TS 23.040: "Technical realization of the Short Message Service (SMS)".

---

## 3 Definitions, symbols and abbreviations

### 3.1 Definitions

For the purposes of the present document, the terms and definitions given in 3GPP TR 21.905 [1] and the following apply. A term defined in the present document takes precedence over the definition of the same term, if any, in 3GPP TR 21.905 [1].

**Content of Communication (CC):** The content of communication as forwarded from the Mediation and Delivery Function 3 (over the LI\_HI3 interface) to the Law Enforcement Monitoring Facility.

**Control Plane (CP) Entity:** The network elements or network functions responsible for handling the Control Plane Functions. These include the SGW and PGW in EPS without CUPS, the SGW-C and PGW-C in EPS with CUPS and the SMF in 5GS.

**CUPS:** As defined in 3GPP TS 23.214 [12], represents PLMN with architecture enhancements for control and user plane separation of EPC nodes.

**Intercept Related Information (IRI):** The intercept related information as forwarded from the Mediation and Delivery Function 2 (over the LI\_HI2 interface) to the Law Enforcement Monitoring Facility.

**IRI event:** The network procedure or event that created an xIRI in the Point Of Interception.

**LI component:** The function and equipment involved in handling the Lawful Interception functionality in the CSP's network.

**Lawful Interception Identifier (LIID):** Unique identifier that associates a warrant to Lawful Interception Product delivered by the CSP to the LEA.

**LI system:** The collection of all LI components involved in handling the Lawful Interception functionality in the CSP's network.

**Non-3GPP Access Entity (N3A Entity):** The network functions responsible for interworking between 3GPP Core Network Functions and Non-3GPP access networks. These include TWIF, TNGF, N3IWF and W-AGF.

**Non-local ID:** An identity assigned and managed at a different CSP than the CSP performing LI.

**Provisioning:** The action taken by the CSP to provide its Lawful Interception functions information that identifies the target and the specific communication services of interest to the LEA, sourced from the LEA provided warrant.

**Triggering:** The action taken by a dedicated function (Triggering Function) to provide another dedicated function (Triggered POI), that Provisioning could not directly be applied to, with information that identifies the specific target communication to be intercepted.

**User Plane (UP) Entity:** The network elements or network functions responsible for handling the User Plane Functions. These include the SGW and PGW in EPS without CUPS, the SGW-U and PGW-U in EPS with CUPS and the UPF in 5GS.

**Warrant:** The formal mechanism to require Lawful Interception from a LEA served to the CSP on a single target identifier. Depending on jurisdiction also known as: intercept request, intercept order, lawful order, court order, lawful order or judicial order (in association with supporting legislation).

**xCC:** The content of communication as forwarded from the Point Of Interception (over the LI\_X3) interface to the Mediation and Delivery Function 3.

**xIRI:** The intercept related information as forwarded from the Point Of Interception (over the LI\_X2) interface to the Mediation and Delivery Function 2.

## 3.2 Symbols

## 3.3 Abbreviations

For the purposes of the present document, the abbreviations given in 3GPP TR 21.905 [1] and the following apply. An abbreviation defined in the present document takes precedence over the definition of the same abbreviation, if any, in 3GPP TR 21.905 [1].

5GC	5G Core Network
5GS	5G System
AAAnF	AKMA Anchor Function
ADMF	LI Administration Function
AF	Application Function
AF_ID	Application Function Identity
AKA	Authentication and Key Agreement
A-KID	AKMA Key IDentifier
AKMA	Authentication and Key Management for Applications
AMF	Access and Mobility Management Function
AS	Application Server
AUSF	Authentication Server Function
BBIFF	Bearer Binding Intercept and Forward Function
BSS	Business Support System
CAG	Closed Access Group
CC	Content of Communication
CP	Control Plane
CPIM	Common Presence and Instant Messaging
CPS	Call Placement Service
CSI	Cell Supplemental Information
CSP	Communication Service Provider
CUPS	Control and User Plane Separation
DN	Data Network
DNAI	Data Network Access Identifier
DoNAS	Data over NAS
EAP	Extensible Authentication Protocol
eCNAM	Enhanced Calling Name
E-CSCF	Emergency – Call Session Control Function
GPSI	Generic Public Subscription Identifier
HMEE	Hardware Mediated Execution Enclave
HR	Home Routed
IBCF	Interconnection Border Control Functions
ICF	Identity Caching Function
IEF	Identity Event Function
IMS-AGW	IMS Access Gateway
IM-MGW	IM Media Gateway
IP	Interception Product
IQF	Identity Query Function
IRI	Intercept Related Information
K <sub>AF</sub>	AKMA Application Key
K <sub>AKMA</sub>	AKMA Anchor Key
KID	Key IDentifier



K <sub>LI</sub>	Decryption key(s) for services encrypted by CSP-provided keys
KSF	Key Server Function
LALS	Lawful Access Location Services
LBO	Local Break Out
LEA	Law Enforcement Agency
LEMF	Law Enforcement Monitoring Facility
LI	Lawful Interception
LI CA	Lawful Interception Certificate Authority
LICF	Lawful Interception Control Function
LI_HI1	Lawful Interception Handover Interface 1
LI_HI2	Lawful Interception Handover Interface 2
LI_HI3	Lawful Interception Handover Interface 3
LI_HI4	Lawful Interception Handover Interface 4
LI_HIQR	Lawful Interception Handover Interface Query Response
LIID	Lawful Interception Identifier
LIPF	Lawful Interception Provisioning Function
LIR	Location Immediate Request
LI_SI	Lawful Interception System Information Interface
LISSF	Lawful Interception State Storage Function
LI_ST	Lawful Interception State Transfer Interface
LI_T1	Lawful Interception Internal Triggering Interface 1
LI_T2	Lawful Interception Internal Triggering Interface 2
LI_T3	Lawful Interception Internal Triggering Interface 3
LI_X0	Lawful Interception Internal Interface 0
LI_X1	Lawful Interception Internal Interface 1
LI_X2	Lawful Interception Internal Interface 2
LI_X3	Lawful Interception Internal Interface 3
LI_X3A	Lawful Interception Internal Interface 3 Aggregator
LI_XEM1	Lawful Interception Internal Interface Event Management Interface 1
LI_XER	Lawful Interception Internal Interface Event Record
LI_XQR	Lawful Interception Internal Interface Query Response
LMF	Location Management Function
LMISF	LI Mirror IMS State Function
LMISF-CC	LMISF for the handling of CC
LMISF-IRI	LMISF for the handling of IRI
LTF	Location Triggering Function
MA	Multi-Access
MANO	Management and Orchestration
MDF	Mediation and Delivery Function
MDF2	Mediation and Delivery Function 2
MDF3	Mediation and Delivery Function 3
MRFP	Multimedia Resource Function Processor
MSRP	Message Session Relay Protocol
N3A	Non-3GPP Access
N3IWF	Non 3GPP Inter Working Function
N9HR	N9 Home Routed
NAS	Non-Access Stratum
NEF	Network Exposure Function
NFV	Network Function Virtualisation
NFVI	Network Function Virtualisation Infrastructure
NFVO	Network Function Virtualisation Orchestrator
NIDD	Non-IP Data Delivery
NPLI	Network Provided Location Information
NR	New Radio
NRF	Network Repository Function
NSSF	Network Slice Selection Function
OSS	Operations Support System
PAG	POI Aggregator
PCF	Policy Control Function
P-CSCF	Proxy - Call Session Control Function
PEI	Permanent Equipment Identifier
PGW	PDN Gateway

PGW-C	PDN Gateway Control Plane
PGW-U	PDN Gateway User Plane
POI	Point Of Interception
PLMN	Public Land Mobile Network
PTC	Push to Talk over Cellular
RCD	Rich Call Data
RCS	Rich Communication Suite
S8HR	S8 Home Routed
SCEF	Service Capability Exposure Function
SCS	Service Capability Server
SGW	Serving Gateway
SGW-C	Serving Gateway Control Plane
SGW-U	Serving Gateway User Plane
SHAKEN	Signature-based Handling of Asserted information using toKENS
SIRF	System Information Retrieval Function
S-CSCF	Serving - Call Session Control Function
SIP	Session Initiation Protocol
SMF	Session Management Function
SMSF	SMS-Function
STF	Security Terminating Function
STIR	Secure Telephony Identity Revisited
SUCI	Subscriber Concealed Identifier
SUPI	Subscriber Permanent Identifier
TF	Triggering Function
TLS	Transport Layer Security
TNGF	Trusted Non-3GPP Gateway Function
TrGW	Transit Gateway
TWIF	Trusted WLAN Interworking Function
UDM	Unified Data Management
UDR	Unified Data Repository
UDSF	Unstructured Data Storage Function
UPF	User Plane Function
VNF	Virtual Network Function
VNFC	Virtual Network Function Component
W-AFG	Wireline Access Gateway Function
xCC	LI_X3 Communications Content
xIRI	LI_X2 Intercept Related Information

---

## 4 Requirements realisation

The LI architecture set out in the present document is designed to allow CSP deployments to meet the set of LI requirements described in TS 33.126 [3] that are determined to be applicable by the relevant national regulation for that deployment. For more details on the relationship between LI requirements and national legislation, see TS 33.126 [3] clause 4.

A CSP may deploy different network technologies or services considered in the present document. A CSP should consider each of these network technologies or services separately with respect to the present document, bearing in mind that a different subset of LI requirements may apply according to relevant national legislation, and that a warrant may require the CSP to intercept multiple network technologies or services.

---

## 5 Functional architecture

### 5.1 General

The following clauses describe the high-level functional architecture for LI for 3GPP-defined services and network technologies. It describes the architectural elements necessary for LI, their roles and responsibilities, and the interfaces and interactions between them.

Clauses 6 and 7 of the present document describe how the LI for various 3GPP-defined network technologies and services are realised within the generic LI architecture, including associations of LI architectural elements with the network functions involved.

Not all LI architectural elements and interfaces are used in all network technologies and services.

## 5.2 High-level generic LI architecture

The overall conceptual view of LI architecture is shown in figure 5.2-1 below.

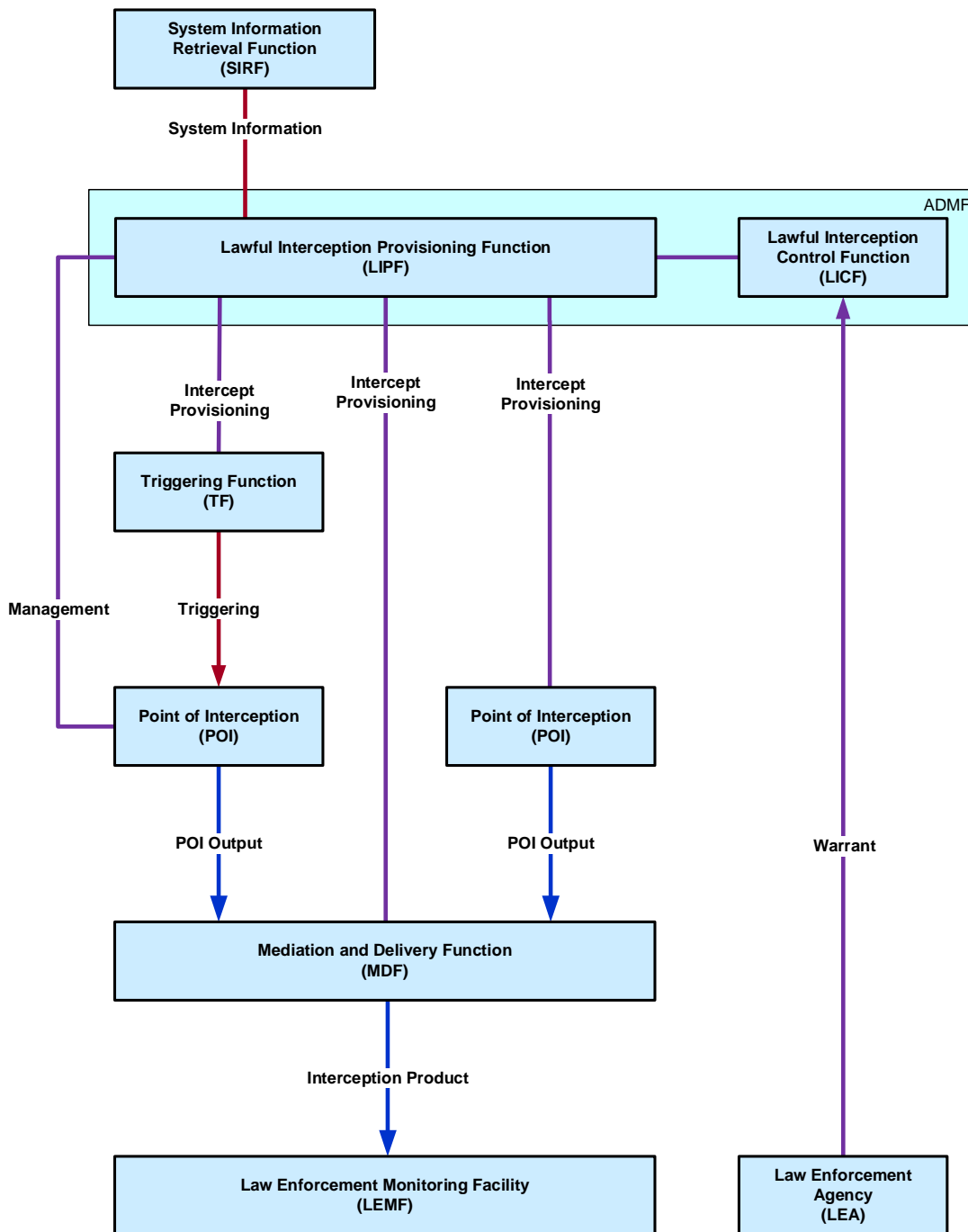

Figure 5.2-1: A high-level generic view of LI architecture

The functional entities of the architecture are described in more detail in clause 5.3 below. Details of the specific interfaces between these entities are described in clause 5.4.

## 5.3 Functional entities

### 5.3.1 Law Enforcement Agency (LEA)

In general the LEA is responsible for submitting the warrant to the CSPs, although in some countries the warrant may be provided by a different legal entity (e.g. judiciary).

### 5.3.2 Point of Interception (POI)

#### 5.3.2.1 General

The **Point of Interception (POI)** detects the target communication, derives the intercept related information or communications content from the target communications and delivers the POI output as xIRI to the MDF2 or as xCC to the MDF3. The output of a POI is determined by the type of the NF associated with the POI. A POI may be embedded within a Network Function (NF) or separate from a NF with which it is associated.

Multiple POIs may have to be involved in executing a warrant.

#### 5.3.2.2 Directly provisioned and triggered POIs

POIs are divided into two categories:

- Directly provisioned POIs are provisioned by the LIPF.
- Triggered POIs are triggered by a Triggering Function (TF) (see clause 5.3.3).

The directly provisioned POIs detect the target's communications that need to be intercepted, and then derive the intercept related information or communication contents from that target communications depending on the POI type (see clause 5.3.2.3). The triggered POIs detect the target communications based on the trigger received from an associated Triggering Function and then derives the intercept related information or communication contents of target communications depending on the POI type (see clause 5.3.2.3).

#### 5.3.2.3 IRI-POIs and CC-POIs

POIs are divided into two types for each category based on the type of data they send to the MDF (see clause 5.3.4):

- IRI-POI delivers xIRI to the MDF2.
- CC-POI delivers xCC to the MDF3.

Both IRI-POIs and CC-POIs are either directly provisioned or triggered (see clause 5.3.2.2).

In the present document, an xIRI is identified with the event that has caused its generation within the IRI-POI.

#### 5.3.2.4 Failure handling

In case a network procedure involving the target UE and requiring the generation of an xIRI fails, the IRI-POI shall be able to report the failure reason available from the involved network protocol.

### 5.3.3 Triggering Function

The **Triggering Function (TF)** is provisioned by the LIPF and is responsible for triggering triggered POIs in response to network and service events matching the criteria provisioned by the LIPF. The Triggering Function detects the target communications and sends a trigger to the associated triggered POI.

As a part of this triggering, the Triggering Function shall send all necessary interception rules (i.e. rules that allow the POIs to detect the target communications), forwarding rules (i.e. MDF2, MDF3 address), target identity, and the correlation information.

A Triggering Function may interact with other POIs to obtain correlation information. Details of this interface are not specified by the present document.

The Triggering Function that triggers CC-POI is referred to as a CC-TF and the Triggering Function that triggers an IRI-POI is referred to as IRI-TF.

### 5.3.4 Mediation and Delivery Function (MDF)

The **Mediation and Delivery Function (MDF)** delivers the Interception Product to the Law Enforcement Monitoring Facility (LEMF).

Two variations of MDF are defined: MDF2 and MDF3.

MDF2 generates the IRI messages from the xIRI and sends them to one or more LEMFs. The MDF3 generates the CC from the xCC and delivers it to one or more intercepting LEMFs. An overview of this is shown in figure 5.3-2 below.

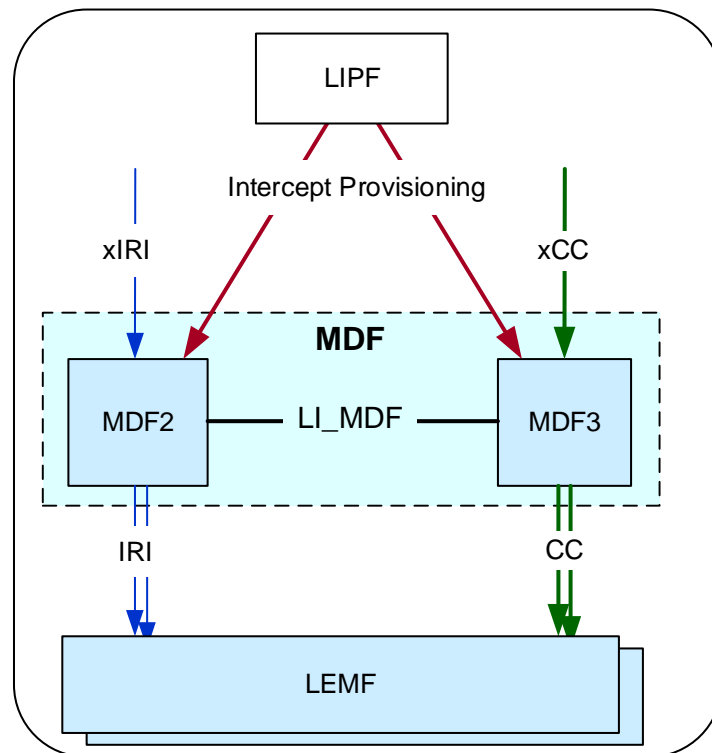

**Figure 5.3-2: MDF2 and MDF3**

The MDF2 and MDF3 are provisioned by the LIPF with the intercept information necessary to deliver the IRI and/or CC to one or more LEMFs.

The LI\_MDF interface between MDF2 and MDF3 (shown in figure 5.3-2) allows the MDF3 and MDF2 to exchange information between the two.

### 5.3.5 Administration Function (ADMF)

#### 5.3.5.1 General

The Administration Function (ADMF) provides the CSP's administrative and management functions for the LI capability. This includes overall responsibility for the provisioning/activating, modifying, and de-activating/de-provisioning the Point(s) Of Interception (POI), Triggering Functions (TF), and the Mediation and Delivery Functions

(MDF). The ADMF is also responsible managing the Identifier Event Functions (IEF) and Identifier Caching Function (ICF).

The ADMF includes four logical sub-functions:

- Lawful Interception Control Function (LICF).
- Lawful Interception Provisioning Function (LIPF).
- Identifier Query Function (IQF).
- Certificate Authority (CA).

Within one ADMF there is one LICF, one IQF and at least one, but possibly multiple LIPFs.

The LICF and LIPF communicate via the internal LI\_ADMF interface, the details of which are outside the scope of the present document.

The ADMF contains the issuing Certificate Authority (CA) for all LI components (POIs, MDFs etc.). Further details are defined in clause 8.3.

The IQF is used for handling identifier association requests. Further details are defined in clause 5.7.

**NOTE:** It is assumed that the LICF and IQF are always implemented on dedicated LI infrastructure which is only accessible to CSP personnel explicitly authorised to handle LI. However, the LIPF is assumed in some scenarios (e.g. virtualisation) to be implemented within the main CSP network infrastructure environment, although still only accessible to LI authorised CSP personnel.

For further details on the roles and responsibilities of the ADMF refer to Annex B.

### 5.3.5.2 LICF

The LICF controls the management of the end-to-end life cycle of a warrant. The LICF contains the master record of all sensitive information and LI configuration data. The LICF is ultimately responsible for all decisions within the overall LI system. The LICF, via the LIPF acting as its proxy is responsible for auditing other LI components (POIs, MDFs etc.). The LICF is responsible for communication with administrative LEA systems (LI\_HI1).

The LICF provides the intercept information derived from the warrant for provisioning at the POI, TF, MDF2 and MDF3. With the exception of the communication with the LEA, all other communication between the LICF and any other entities shall be proxied by the LIPF.

The LICF also maintains and authorises the master list of POIs, IEFs, ICF, TFs and MDFs. In dynamic networks the LIPF is responsible for providing the LICF with any necessary updates to the POI, TF, IEF, ICF and MDF list.

The LICF is responsible for management and audit of the IEF(s) and ICF proxied by the LIPF.

The LICF shall support activating and deactivating of IEF identifier association reporting capabilities on a per IEF basis proxied by the LIPF.

The LICF shall provide the IQF with information relating to IEFs and ICF necessary for the IQF to handle queries from the LEA and obtain answers to such queries.

If the LICF deactivates event record reporting to an IEF, the LICF shall also instruct the ICF to immediately delete all cached identifier associations which the ICF had received from that IEF.

The LICF shall ensure that the ICF is always activated before IEFs and de-activated after IEFs to ensure that data loss does not occur due to an IEF sending events before an ICF is configured to receive them.

### 5.3.5.3 LIPF

The LIPF provisions all the applicable POIs, TFs and MDFs.

The role of the LIPF varies depending on implementation of network functions and of the ADMF itself (e.g. virtual or non-virtual).

In its simplest form, the LIPF is the secure proxy used by the LICF to communicate with POIs, TFs, MDFs or other infrastructure required to operate LI within the CSP network. In this scenario the LIPF does not store target information and simply routes LI\_X1 messages from and to the LICF.

In scenarios where the ADMF is required to take an active role in POI triggering, the LIPF is responsible for receiving triggering information (e.g. from an IRI-TF) and forwarding the trigger to the appropriate POI.

For directly provisioned POIs, TFs and MDFs, the LIPF will forward all LI administration instructions from the LICF to the intended destination POI, TF or MDF.

In SBA as defined in TS 23.501 [2] or virtualised deployments, the LIPF is responsible for identifying changes to NFs, POIs, and TFs and MDFs through interaction with the SIRF or underlying virtualisation infrastructure. The LIPF shall notify the LICF of changes affecting the number of active NFs/POIs and TFs or other information which the LICF requires to maintain the master POI/TF and MDF list.

While the LIPF is assumed to be stateful with respect to dynamic interceptions it is managing, it shall not hold the full static target or other historic LI data. If the LIPF is deployed in a virtualised environment, the LIPF shall not store LI information in persistent storage and shall rely on the LICF to manage re-synchronisation in the case of LIPF restart.

#### 5.3.5.4 IQF

The IQF is the function responsible for receiving and responding to dedicated LEA real-time queries for identifier associations. Further details of the IQF are defined in clause 5.7.2.1.

#### 5.3.5.5 LI Function Selection

The LICF and LIPF shall support selective management and provisioning of groups of POIs, TFs and IEFs, based on the warrant parameters (e.g., service scope, target identities), the target UE type and profile (e.g. a smartphone, a CIoT device) and the CSP's network deployment architecture and services implementation (e.g. Slicing, MEC and URLLC enablers, etc.), with the purpose of optimizing the LI system operation and avoiding its over-provisioning. This selective management and provisioning shall apply independently of architectural alternatives in clause 8.2.

The selective management and provisioning of LI functions may be supported by ADMF's GUI configuration capabilities, as well as by ADMF's ability to obtain and use the CSP network data to drive its provisioning decisions.

The following are examples of the ADMF's configuration capabilities:

- Single or multiple POIs or TFs or IEFs.
- Groups of one or more POIs, TFs, and IEFs of a specific parent NF type.
- POIs, TFs, and IEFs associated with NFs in a specific slice.
- POIs, TFs, and IEFs independently where they are contained in the same parent NF.
- Enabling only specific services or features of POIs (individually and in groups).

Selective provisioning shall be supported on a per warrant basis.

**NOTE:** The criteria by which the CSP decides which POIs, IEFs and TFs to select is outside the scope of the present document except where the ADMF is able to make selections using information provided by the SIRF (e.g. all POIs and TFs in a slice).

### 5.3.6 System Information Retrieval Function (SIRF)

The **System Information Retrieval Function (SIRF)** is responsible for providing the LIPF with the system related information for NFs that are known by the SIRF (e.g. service topology). The information provided shall allow the LIPF/LICF to perform the necessary operations to establish and maintain interception of the target service (e.g. provisioning POIs, TFs and MDFs over LI\_X1). LIPF/LICF knowledge of POI, TF and MDF existence is provided directly by interactions between the LIPF/LICF and the underlying CSP management systems that instantiate NFs (as defined in clause 5.5). The NRF/SIRF are not involved in this step of NF/POI or MDF instantiation.

While the LIPF is responsible for interactions with the SIRF, the LIPF will forward applicable information to the LICF. Details of LIPF vs LICF responsibilities in managing and maintaining interception are defined in clause 5.3.2.

As described in clause 5.6 of the present document, the OSS/BSS is responsible for managing the number of NFs within the network including the NF within which the SIRQ is implemented. Therefore, the SIRQ is not responsible for notifying the LIPF that a new NF, POI, TF or MDF has been instantiated (in virtualised networks) or connected to the network using manual processes (legacy networks). The LIPF is notified of these events directly by the relevant CSP management system as described in clause 5.6, prior to any interaction with the SIRQ. When the SIRQ subsequently notifies the LIPF that, for example an NF associated with a POI has now been registered with the SIRQ, the LIPF knows that an NF and POI which it has already configured for LI usage is ready for live user traffic service.

**NOTE:** The SIRQ will only become aware of the existence of NFs after they are commissioned for use within the network and are ready for service usage (NFs are authorised, instantiated and configured for network connectivity before the SIRQ will become aware of them). By this stage the NF may be only several milliseconds away from live user traffic handling. This is too late to check whether the LI components are functional and therefore the SIRQ is not involved in NF instantiation reporting to the LIPF.

In virtualised networks where selective per POI provisioning of target identifiers is not required, or only limited network static network slicing is in use, implementation of the SIRQ is not required to allow the LIPF and LICF to meet LI requirements.

### 5.3.7 LEMF – Law Enforcement Monitoring Facility

The **Law Enforcement Monitoring Facility (LEMf)** receives the Interception Product. The **LEMf** is out of scope of the present document.

## 5.4 LI interfaces

### 5.4.1 General

A high-level LI architecture diagram showing key point-to-point LI interfaces is shown in figure 5.4-1 below.



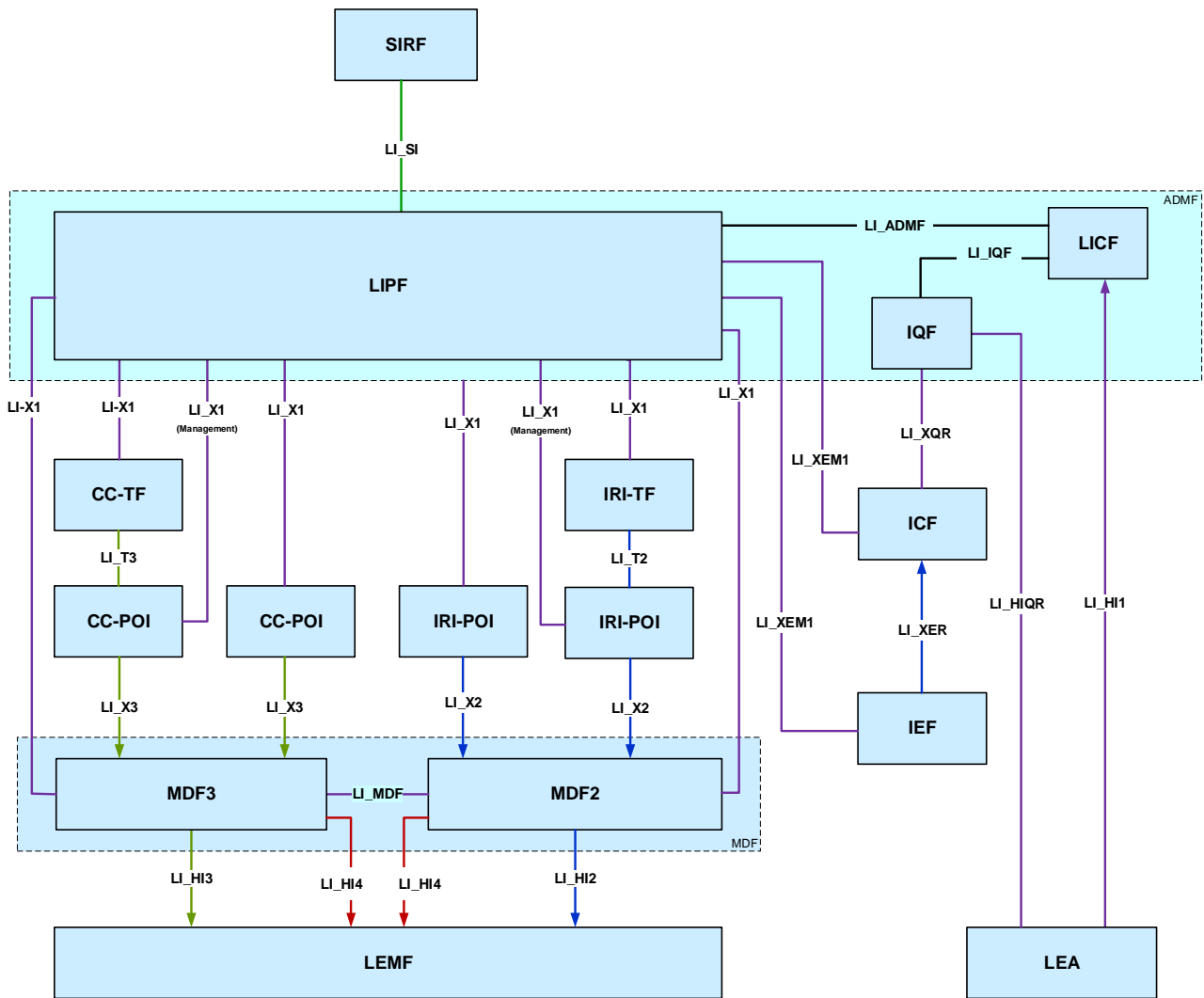

Figure 5.4-1: High-level architecture diagram with key point-to-point LI interfaces

### 5.4.2 Interface LI\_SI

LI\_SI is an interface between the SIRF and LIPF. SIRF uses this interface to provide the system information to the LIPF. The LIPF may request the SIRF for such information before sending the intercept provisioning information to the POIs. The SIRF may also notify the LIPF whenever the status of a system function changes (e.g. removed from service, migrating to another location, etc.).

### 5.4.3 Interface LI\_HI1

LI\_HI1 is used to send warrant and other interception request information from the LEA to the CSP. This interface may be electronic or may be an offline manual process depending on national warranty processes.

The following are some of the information elements sent over this interface:

- Target identifier: used to identify the communications to be intercepted.
- Type of intercept: used to indicate whether IRI only, CC only, or both IRI and CC, is to be delivered to the LEMF.
- Service scoping: used to identify the service (e.g. voice, packet data, messaging, target positioning) to be intercepted.
- Filtering criteria: used to provide additional specificity for the interception (e.g. for bandwidth optimization).
- LEMF address: used to deliver the Interception Product.

- Lawful Interception Identifier (LIID) used to associate the issued warrant with the Interception Product.

LI\_HI1 interfaces shall support the use of ETSI TS 103 120 [7] for communication of warrant information between the LEA and CSP. However, default configurations, information element formats and other parameters as defined in the present document shall apply regardless of generic default options specified in ETSI TS 103 120 [7].

## 5.4.4 Interface LI\_X1

### 5.4.4.1 General

LI\_X1 interfaces are used to manage the POIs and TFs and to provision LI target information on the POIs and TFs in order to intercept target communications. LI\_X1 interfaces are also used to manage and provision MDFs with the necessary information to deliver those communications in the correct format to LEMFs.

LI\_X1 interfaces shall support the use of ETSI TS 103 221-1 [8] for transport of X1 messages / information. However, the requirements specified in the present document shall apply regardless of generic default options specified in TS 103 221-1 [8].

### 5.4.4.2 LIPF and POI

The following are examples of some of the information that may be passed over LI\_X1 to the POI as a part of intercept provisioning:

- Information necessary to associate multiple xIRI/xCC at MDF2/MDF3.
- Target identifier.
- Type of intercept (IRI only; CC only; or IRI and CC).
- Service scoping.
- Further filtering criteria.
- Address of MDF2 or MDF3.

The exact nature of the information passed depends on the role of the POI.

The LI\_X1 interface between the LIPF (in the ADMF) and a Triggered POI shall be used only for audit and management purposes, and not for provisioning purposes.

### 5.4.4.3 LIPF and TF

The following are examples of some of the information that may be passed over LI\_X1 to the TF as a part of intercept provisioning:

- Information necessary to associate multiple xIRI/xCC at MDF2/MDF3.
- Target identifier.
- Type of intercept (IRI only; CC only; or IRI and CC).
- Service scoping.
- Further filtering criteria.
- Address of MDF2 or MDF3.

The exact nature of the information passed depends on the role of the TF.

### 5.4.4.4 LIPF and MDF2/MDF3

The following are examples of some of the information that may be passed over LI\_X1 to the MDF2/MDF3 as a part of intercept provisioning:

Information necessary used to associate multiple xIRI/xCC at MDF2/MDF3.

- Target identifier.
- Lawful Interception identifier.
- Type of intercept (IRI only; CC only; or IRI and CC).
- Service scoping.
- Further filtering criteria.
- LEMF address.

The exact nature of the information passed depends on the role of the MDF.

### 5.4.5 Interface LI\_X2

The LI\_X2 interfaces are used to pass xIRI from IRI-POIs to the MDF2.

The following are some of the information passed over this interface to the MDF2 as a part of xIRI:

- Target identifier.
- Time stamp.
- Correlation information.
- IRI event resulting in xIRI.

### 5.4.6 Interface LI\_X3

LI\_X3 interfaces are used to pass real-time content of communications (i.e. xCC) and associated metadata from CC-POIs to MDF3.

The following are some of the information passed over this interface to the MDF3 as a part of xCC:

- Target identifier.
- Time stamp.
- Correlation information.
- User plane packets.

### 5.4.7 Interface LI\_T

#### 5.4.7.1 General

The LI\_T interface is used to pass the triggering information from the Triggering Function to the POI. Depending on the POI type, two types of LI\_T are defined:

- LI\_T2.
- LI\_T3.

LI\_T2 is used when POI output is sent over LI\_X2 and LI\_T3 is used when POI output is sent over LI\_X3.

#### 5.4.7.2 Interface LI\_T2

The LI\_T2 interface is from IRI-TF to IRI-POI.

The following are some of the information passed over this interface to the IRI-POI:

- Target identifier.
- IRI interception rules.
- MDF2 address.
- Correlation information.

The IRI interception rules allow the IRI-POI to detect the target communication information to be intercepted.

### 5.4.7.3 Interface LI\_T3

LI\_T3 interface is from CC-TF to CC-POI.

The following are some of the information passed over this interface to CC-POI:

- Target identifier.
- CC interception rules.
- MDF3 address.
- Correlation information.

The CC interception rules allow the CC-POI to detect the target communication information to be intercepted.

### 5.4.8 Interface LI\_HI2

LI\_HI2 is used to send IRI from the MDF2 to the LEMF. This interface is defined in TS 33.128 [15].

### 5.4.9 Interface LI\_HI3

LI\_HI3 is used to send CC from the MDF3 to the LEMF. This interface is defined in TS 33.128 [15].

### 5.4.10 Interface LI\_HI4

#### 5.4.10.1 General

LI\_HI4 is used by the MDF2 and MDF3 to report to the LEMF that the MDF2/3 have been provisioned as expected. This capability is mandatory to support but optional to use (subject to relevant national agreement) at both MDF2 and MDF3.

NOTE: It is FFS if/how LI\_HI4 interface could be used to report network topology information.

#### 5.4.10.2 LI operation notification

The MDF2 and MDF3 shall support reporting to the LEMF changes to provisioning, including:

- Activation of LI.
- Modification of active LI.
- Deactivation of LI.

NOTE: A mechanism may be needed at the CSP to prevent duplicate notifications being raised in the case of LI being provisioned across multiple MDFs. Such a mechanism is for FFS.

#### 5.4.10.3 Contents of the notification

Each notification shall include at least the following:

- The type of notification (e.g. activation, deactivation).
- Relevant related information (LIID, time of change).

#### 5.4.11 Interface LI\_ADMF

LI\_ADMF is an interface between LICF and LIPF and is used by the LICF to send the intercept provisioning information to the LIPF. Further details about this interface is outside the scope of the present document.

#### 5.4.12 Interface LI\_MDF

LI\_MDF is an interface between MDF2 and MDF3 and is used for MDF2 and MDF3 to interact with each other in the generation of IRI and CC. Further details about this interface is outside the scope of the present document.

#### 5.4.13 Interface LI\_IQF

LI\_IQF is an interface between LICF and IQF and is used by the LICF to send management information related to IEFs and ICF, to the IQF. Further details about this interface is outside the scope of the present document.

#### 5.4.14 Interface LI\_XQR

The LI\_XQR interface is used by the IQF to send identifier association queries to the ICF and from the ICF to return identities associations to the IQF in response.

The following are examples of some of the information that may be passed over LI\_XQR from the IQF to the ICF:

- Information relating to the type of query.
- Temporary or permanent identifier provided by the LEA.
- Other information associated with identifier required for localisation provided by the LEA.
  - Cell identity.
  - Tracking area identifier.
- Time that identifier provided by the LEA was observed by the LEA.
- Location information request from the LEA.

The following are examples of some of the information that may be passed over LI\_XQR from the ICF to the IQF:

- Information relating to the type of query being responded to.
- Temporary and permanent identifiers corresponding to identifier provided by LEA.
- Identifier association validity start and end times.
- Location information for the target, if requested by the LEA.

NOTE: The location information returned in the IQF response is the information associated at the time of the specific identifier association caching at the ICF.

#### 5.4.15 Interface LI\_HIQR

The LI\_HIQR interface is used by the LEA to send identifier association queries to the IQF and from the IQF to return identities associations to the LEA in response.

The following are examples of some of the information that may be passed over LI\_HIQR from LEA to the IQF:

- Information relating to the type of query.
- Warrant/authorisation identifier.

- Temporary or permanent identifier provided by the LEA.
- Other information associated with identifier required for localisation provided by LEA.
  - Cell identity.
  - Tracking area identifier.
- Time that identifier provided by LEA was observed by the LEA.
- Location information request.

The following are examples of some of the information that may be passed over LI\_HIQR from IQF to the LEA:

- Information relating to the type of query being responded to.
- Warrant/authorisation identifier.
- Temporary and permanent identifiers corresponding to identifier provided by LEA.
- Identifier association validity start and end times.
- Location information for the target, if requested by the LEA.

#### 5.4.16 Interface LI\_XER

The LI\_XER interface is used by the IEF to send identifier association events to the ICF.

The following are examples of some of the information that may be passed over LI\_XER from the IEF to the ICF:

- Permanent identifier and temporary identifier association.
- Permanent identifier and temporary identifier excommunication / de-association.
- Time stamp of association observation.
- Location information.

#### 5.4.17 Interface LI\_XEM1

The LI\_XEM1 interface is used by the LICF (proxied by the LIPF) to manage and control the activation state of the IEF(s) and ICF.

LI\_XEM1 interfaces shall support the use of ETSI TS 103 221-1 [8] for transport of XEM1 messages / information. However, the requirements specified in the present document shall apply regardless of generic default options specified in [8].

### 5.5 LI service discovery

In SBA as defined in TS 23.501 [2] the NRF is a central repository of discoverable NFs. For NFs to be discoverable, they need to have been previously instantiated and undergone a degree of configuration (function identity allocated, IP addresses, certificates, network connectivity to NRF, etc.).

LI functions (e.g. ADMF, POIs and MDFs) exist within a separate security domain to the main network NF to which they are embedded. Furthermore, as with legacy networks, LI functions associated with NFs shall be configured and tested before the associated NF is allowed to enter active network user service (i.e. LI shall be configured and tested before an NF can handle live user traffic).

In the present document, all LI functions have dedicated LI\_X interfaces and discovery of LI functions by the LIPF shall happen as part of the NF / LI function instantiation phase. POIs, TFs and MDFs shall not be subject to or within the scope of NRF service discovery as defined in TS 23.501 [2]. The SIRF is used to provide the LIPF with NF discovery information which shall be used to identify which NFs are applicable to intercept specific user sessions, as described in clause 5.3.6. However, the SIRF is not involved directly in LI service discovery.

The SIRF may be used to inform the LIPF that an NF has been registered / deregistered with the NRF and is now ready for use in a network user service. The LIPF is assumed to already have knowledge of which POIs and TFs are associated with which NFs.

POIs, TFs and MDFs may be discovered in virtualised deployments using the approach described in clause 5.6. The exact mechanisms for achieving this are out of scope of the present document.

## 5.6 LI in a virtualised environment

### 5.6.1 General

Virtualisation is one of the 3GPP network deployment options for NFs containing LI functions as described in the present document. In virtualised deployments, many of the initial deployment and configuration actions performed manually in non-virtualised deployments need to be automated and occur in near real-time. This clause outlines the basic architecture enhancements to support virtualised LI in 3GPP networks. Security aspects relating to virtualisation are described in clause 8.

The architecture enhancements in this clause are intended to apply to any virtualised 2G, 3G, 4G, 5G scenario including IMS that needs to support LI. Where legacy network functions defined in TS 33.107 [11] are virtualised, the architecture in figure 5.6-1 shall be applied, with legacy TS 33.107 [11] reference points and functional elements substituted for their equivalent in the present document (e.g. POI is equivalent to ICE and LI\_X2 is equivalent to X2 in TS 33.107 [11]).

### 5.6.2 Virtualised deployment architecture

Figure 5.6-1 shows the necessary extensions to the basic LI architecture described in clause 5.2 required to support real-time deployment of virtualised LI functions. Figure 5.6-1 is a simplified version of the virtual LI function deployment procedures.

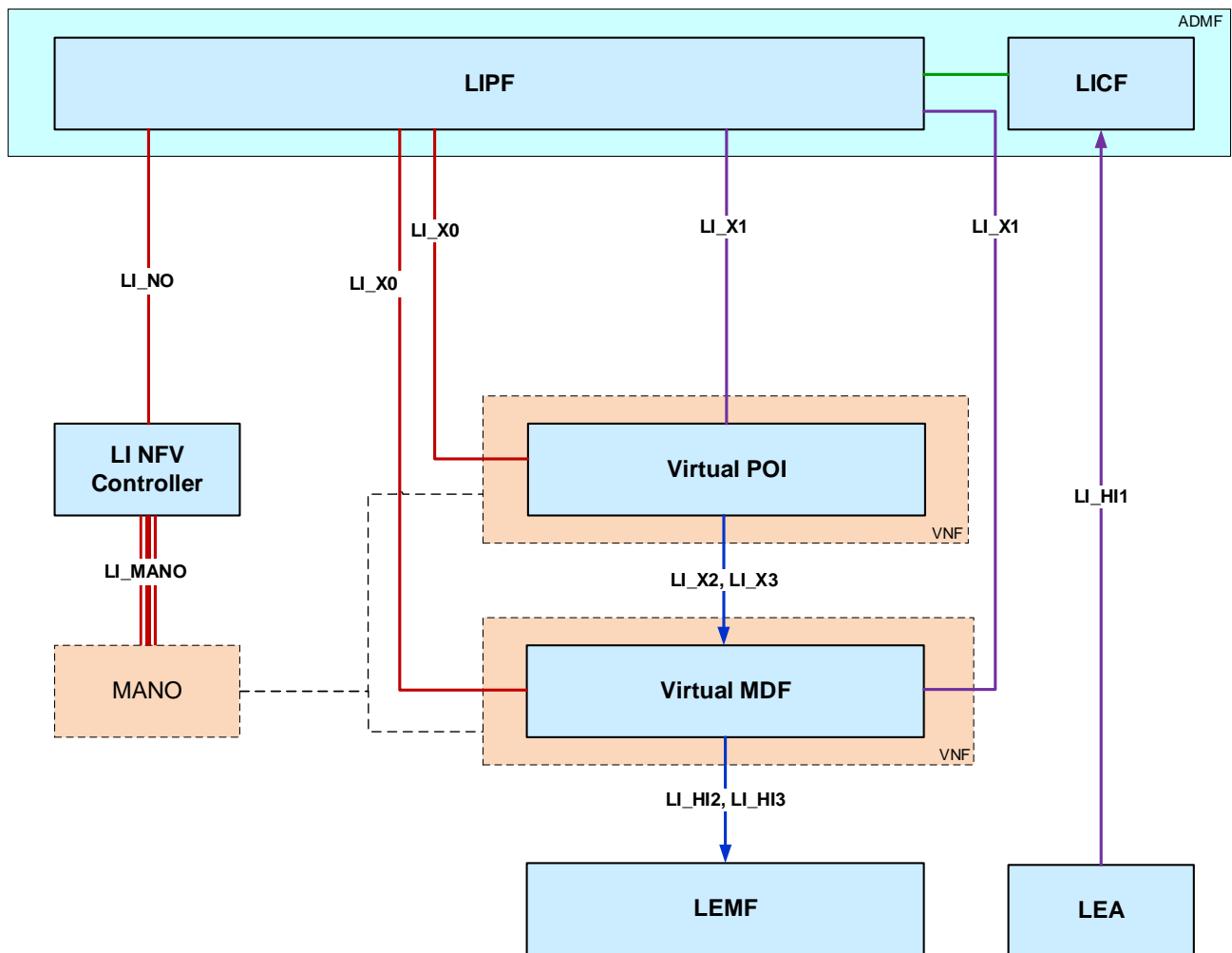

**Figure 5.6-1: Simplified virtualised LI system with provisioning infrastructure for a direct provisioned POI**

Figure 5.6-1 shows the LI NFV controller and NFV Management and Orchestration functions (MANO), together with two logical interfaces:

- LI\_NO: This interface allows to exchange correlation and notification information between the LI application/service and NFV layer about related VNF and VNFC lifecycle management; it also allows to configure optional virtual deployment parameters. In addition, in case of LI functions not instantiated by OSS/BSS (see clause 5.6.3.1.6 of the present document) this interface shall support LI function instantiation requests from the ADMF.
- LI\_MANO: This interface allows to notify the LI NFV controller about VNF/VNFC lifecycle management and enforce virtual deployment LI security policy.

These two interfaces are assumed to be already setup between the involved functional entities via a mutual authenticated and encrypted dedicated connection.

The procedures in clause 5.6.3 assume that the LIPF, LICF and NFV LI Controller already exist before creation of any other LI functions.

The OSS/BSS is responsible for controlling the number of 3GPP VNFs and service chains within the network. The OSS/BSS instructs NFV MANO to instantiate, scale or terminate one or more VNFs. NFV MANO is also able to instantiate and terminate VNF sub-components (VNFCs) dynamically without input from the OSS/BSS in order to maintain performance and resilience requirements. This is especially likely in container-based implementations.

To ensure that all LI related aspects, if applicable, are considered within that VNF, NFV MANO notifies the LI NFV Controller about the VNF and VNFC instantiation, scaling and termination. In case where a VNF, about to be instantiated, is expected to have LI specific functionalities such as POI, TF or MDF, the LI NFV controller notifies the



LIPF about those LI specific functionalities within the VNF. The LIPF would forward that notification to the LICF, which in turn, validate/verify/authorize (via LIPF, of course) that POI/TF/MDF for LI over LI\_X0. If the VNF does not contain an LI function then the LI NFV Controller may still notify the LIPF/LICF.

LI NFV Controller shall be configurable to apply default LI policy and configuration to LI VNFCs without explicit authorisation from the LIPF/LICF, depending on network performance and LI security requirements. The LI NFV Controller shall be able to apply policy on a per instantiation basis or apply a static configuration policy to NFV MANO, which NFV MANO is able to use to automatically instantiate LI components using this default configuration.

In most deployments some default LI configuration information will need to be provided as part of the VNF image packages and package descriptor files. Such LI information needs to be adequately protected within NFV MANO and software catalogues.

Where explicit authorisation of LI components is required, the LIPF would notifies the LI NFV Controller that the LI specific functions are authorized/verified and the LI NFV Controller notifies NFV MANO.

**NOTE:** In figure 5.6.1, LI\_MANO is shown as a combined representation of the up to three separate NFV MANO interfaces provided by ETSI GS NFV IFA 026 [20]. Since the exact number of interfaces required depends on the vendor implementation of the NFVI / NFV MANO and whether a combined single NFVO interface is supported by NFV MANO, the present document treats this a single logical interface labelled as LI\_MANO for 3GPP LI purposes.

## 5.6.3 LI function instantiation and lifecycle management procedures

### 5.6.3.1 Controller virtualisation layer and MANO procedures

#### 5.6.3.1.1 Responsibilities

The 5G NRF is not involved in the discovery of LI functions, as described in clause 5.3.6. NFs containing LI functions shall only be discoverable by the NRF / SIRF once all LI initialisation steps in this clause have been completed and the OSS/BSS/ MANO informed that LI operation is ready. The process by which the NRF / SIRF is notified by the OSS/BSS/MANO is out of scope of the present document.

#### 5.6.3.1.2 General procedures

When the 3GPP network OSS/BSS makes a request to NFV MANO to instantiate, modify or terminate a 3GPP NF, NFV MANO shall notify the LI NFV Controller of the request over LI\_MANO using procedures as described in ETSI GS NFV-IFA 026 [20] or equivalent. The NFV LI Controller shall be able to send all applicable NF changes to the LIPF over LI\_NO, so that the LICF is able to maintain an understanding of network topology. In 5G, the LICF in the ADMF (via the LIPF) also maintains understanding of active use of NF via the NRF / SIRF.

In addition, NFV MANO is required to send notifications of non-OSS/BSS triggered (e.g. NFV MANO automated VNF relocation, or software image update) as described in ETSI GS NFV IFA 026 [20]. The LI NFV Controller shall also be able to provide applicable notifications to the LICF in the ADMF (via the LIPF) of such changes.

**NOTE:** The precise list of information required for the ADMF to maintain understanding of network topology is implementation specific and therefore outside the scope of the present document.

In deployments where the implementation supports data centre / location verification for NFs being instantiated or modified, subject to operator policy the LI NFV Controller shall not allow instantiation or modification of LI functions or associated NFs which do not comply with LI location constraints set by the LICF in the ADMF (via the LIPF).

#### 5.6.3.1.3 Instantiation

Where an NF being instantiated contains one or more LI functions (e.g. POI, TF, MDF) the LI NFV Controller shall handle any necessary steps to allow the LI functions to be instantiated by NFV MANO and the LI functions to be added to the LI environment, so that initial contact between the LI functions and the LIPF in the ADMF can be established. The LI NFV Controller shall provide details of the new LI functions to the LICF in the ADMF (via the LIPF), including the identity of the new LI functions, so that the LICF is aware of the existence of the LI functions.

In deployments where ADMF (LICF) signing of LI function software images has been implemented, the LI NFV Controller shall provide the signatures to the LICF in the ADMF (via the LIPF) for verification and shall only authorise NFV MANO to continue instantiation of the LI function if the LICF has successfully verified the signatures.

NOTE: Once this instantiation step is completed an LI function is considered ready for configuration by the ADMF (LIPF) but is not ready to become a live LI function.

#### 5.6.3.1.4 Modification

When an NF containing LI functions is being modified (e.g. scaled or relocated) the LI NFV Controller shall manage the necessary interactions with NFV MANO (using the procedures in ETSI GS NFV-IFA 026 [20] or equivalent) to allow the LI functions to also be modified in alignment with changes to their parent NF. The LI NFV Controller shall notify the LICF in the ADMF via the LIPF over LI\_NO, of the subsequent modifications. Where the modifications result in a new LI function being instantiated (e.g. where a scale up exceeds the existing capabilities of the existing LI functions and a new VNFC is instantiated), the LI NFV Controller shall notify the LICF about the existence of the new LI function and indicate to which existing NF the new LI function is associated.

#### 5.6.3.1.5 Termination

When an NF containing LI functions is terminated, the LI NFV Controller shall manage the necessary interactions with NFV MANO (using the procedures in ETSI GS NFV IFA 026 [20] or equivalent) and notify the LICF via the LIPF that the LI functions have been removed from the system. The LICF in the ADMF shall ensure that certificates associated with those LI functions are appropriately revoked.

#### 5.6.3.1.6 Direct instantiation of LI Functions by ADMF

Procedures in clauses 5.6.3.1.3, 5.6.3.1.4 and 5.6.3.1.5 are based on the OSS/BSS being responsible for creating all LI functions as part of normal network operations (e.g. LI functions are embedded VNFC within a VNFs or are instantiated as part of network service descriptors where a whole slice or large set of VNFs are instantiated together as part of a complete network service).

In some scenarios, the ADMF needs to create specific virtualised LI functions (e.g. MDF) within the NFVI used to host other operator NFs but for security reasons requires that the OSS/BSS does not manage or have knowledge of these. In this scenario, the LICF, instructs the LI NFV Controller via LIPF over LI\_NO to request NFV MANO via LI\_MANO to instantiate an LI specific image. This LI VNF may either be inserted as part of an existing network service chain or create a new LI specific service chain.

In such scenarios, the ADMF shall play the role of the OSS/BSS and the LI\_NO interface shall support the related operations; the LIPF should implement the equivalent logic of OSS/BSS for these operations.

NOTE: It is assumed that any required LI VNF or VNFC images are available within NFV MANO image software catalogue and the images are not sent over the LI\_NO or LI\_MANO interfaces.

#### 5.6.3.2 LI\_X0 procedures

Only once an LI function has been instantiated and the LIPF in the ADMF informed of that NF's existence, can that NF be managed by the LIPF in the ADMF over LI\_X0. Such notification is achieved as described in clause 5.6.3.1 over LI\_NO and LI\_MANO and occurs prior to any SIRF/NRF (or equivalent) NF discovery processes.

The LI\_X0 interface is used to manage LI functions after instantiation such they are made ready for LI use and subsequent provisioning over LI\_X1.

After a VNF is instantiated (e.g. using the procedures in ETSI GR NFV-SEC 011 [10] and ETSI NFV-IFA 026 [20] or equivalent), it is necessary to automatically configure the LI functions (e.g. POI, TF, MDF) before use (i.e. to initialise it to a state where it can accept LI\_X1 messages). To achieve this the LI Function shall after instantiation and initial network configuration by NFV MANO (e.g. allocation of network IP address and FQDN) contact the LIPF over the LI\_X0 interface and LIPF will notify the LICF that a new potential LI function has contacted the LIPF. The LIPF shall only accept incoming connections from new LI functions that have previously been notified to the LIPF/LICF by the LI NFV controller over LI\_NO. The LI\_NO interface shall carry information to allow the LIPF to associate a VNF instance with the LI application instance running in it.

The LICF in the ADMF, through the LIPF, shall verify the authenticity of the LI function over LI\_X0 in order to verify that the new LI function has been instantiated from a valid software image. If the LI function software image has been partly encrypted as described in ETSI GR NFV-SEC 011 [10], then once the LICF has verified the integrity of the LI function it shall provide any necessary keys to the LIPF to decrypt the LI function to complete instantiation of that LI function.

Once a trust relationship has been established between the LICF and new LI function, the LIPF shall issue the LI function with an LI identity (e.g. POI CSCF number 42 or LI System FQDN) and provide the other necessary certificates and configuration information to allow the new LI function to be configured for LI use on LI\_X1. The LICF is responsible for providing necessary information and policy rules necessary for the LIPF to perform configuration of LI functions over LI\_X0. For the purposes of instantiation IEFs and ICF follow the same instantiation flow as POIs except that the LIPF has a more limited role in managing these functions after instantiation over LI\_XEM1 compared to POIs as neither of these types of LI functions are subject to LI provisioning.

In the case of triggered POIs which are not directly provisioned by the LIPF in the ADMF over LI\_X1, the LIPF is still responsible for LI\_X0 configuration of the POI including identity manage and all necessary identity / communication certificates in order to allow the POIs and TF to communicate over LI\_X1, LI\_T2 and LI\_T3. The same applies to virtualised MDFs or CC-PAG.

Once an LI function directly associated with or embedded in an NF has been made fully ready for provisioning over LI\_X1 using LI\_X0, the LICF in the ADMF via the LIPF shall notify the LI NFV Controller that the LI function is ready for service and NFV MANO may advise the OSS/BSS that the NF associated with the LI functions is ready for service and discovery by the NRF. For MDFs, CC-PAGs, or non-embedded POIs the LICF may still need to provide a ready for service indication to NFV MANO / OSS / BSS depending on the implementation scenario.

**NOTE:** The full procedure for notifying the OSS/BSS that LI is ready and that the NF can be notified to the NRF (in the case of 5G SBA) is out of scope of the present document and is left to operator deployment choice.

During normal system operation LI\_X0 shall be used by the LIPF in the ADMF to maintain the LI function throughout the LI function's lifecycle, except as a result of scaling or other changes applied by NFV MANO (such changes are first managed by the NFV LI Controller through LI\_NO and LI\_MANO and any necessary LI\_X1/LI\_X2/LI\_X3 level re-configuration then applied over LI\_X0). In-life certificate updates, identity changes, LI\_X1/2/3 credential changes and other similar configuration changes shall be supported by both the LIPF in the ADMF and LI functions over LI\_X0.

Figure 5.6-2 shows an example of what the procedures described in this clause look like when instantiating a new NF and associated LI functions.

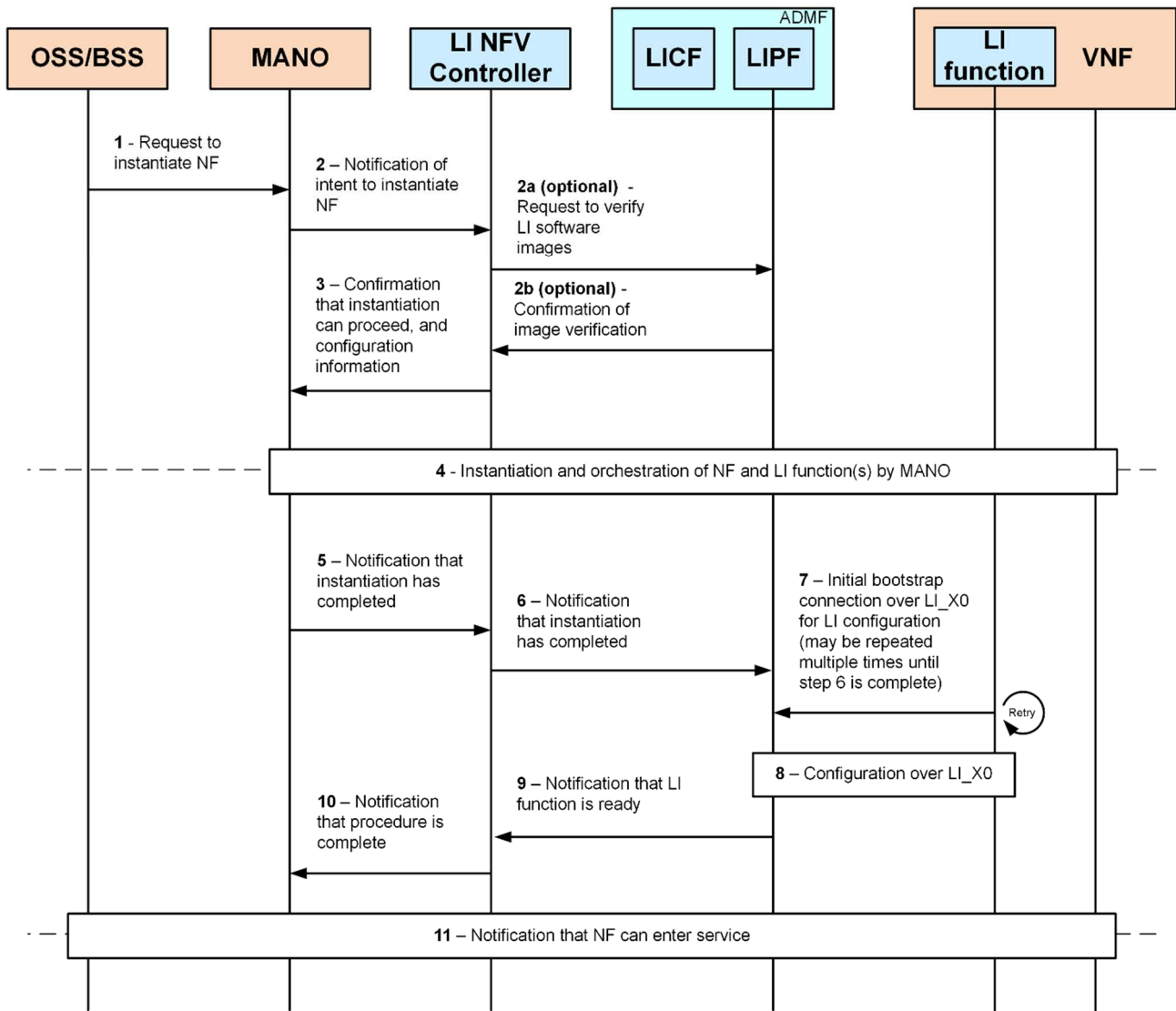

Figure 5.6-2: Example simplified flow-diagram for OSS / BSS originated LI instantiation procedures

### 5.6.3.3 Exception Procedures

If during normal LI system operation the ADMF (LIPF or LICF) detects or is informed of abnormal LI function behaviour, then subject to operator policy the LICF in the ADMF via the LIPF shall be able via the LI NFV Controller over LI\_NO and LI\_MANO to request immediate termination or quarantine of the LI function to NFV MANO as defined in ETSI GS NFV-IFA 026 [20]. For this purpose, the LI NFV Controller acts as a Semi-Active SM as described in ETSI GS NFV-IFA 026 [20].

If during normal operation the LICF in the ADMF via the LIPF is notified of a NF modification or instantiation event which does not comply with operator LI policy (e.g. NF location is not within allowed locations or LI functionality is not authorised for a given deployment scenario) the LICF via the LIPF shall be able to deny NFV MANO and the OSS/BSS authorisation to complete the system change. The ADMF shall be able to delegate responsibility for real-time termination handling to the NFV LI Controller. The NFV LI Controller shall be responsible for reporting detected events and subsequent actions taken by LI NFV Controller and NFV MANO to the LICF via the LIPF over LI\_NO.

## 5.7 Identifier association and reporting

### 5.7.1 General

3GPP networks use temporary identifiers in place of permanent identifiers to ensure that identities which are visible on exposed interfaces (e.g. RAN) cannot be used to track or degrade the privacy of a subscriber. For LI purposes, CSPs are required to be able to provide real-time association between temporary and permanent identifiers where the use of such identifier associations impact the ability of the LEA to uniquely identify the UE, subscriber or true permanent identifiers associated with a service.

The present document defines two sets of capabilities which allow CSPs to report such association to LEAs:

- Real-time reporting of associations as observed by POIs as part of network access, target communications and service usage.
- Dedicated real-time query, lookup and reporting of identifier associations.

For real-time reporting based on POI observation, associations are reported through a combination of dedicated event records sent from the POI to the MDF over LI\_X2 and through inclusion of specific parameters in other communications service records reported over LI\_X2.

For dedicated query, lookup and reporting, figure 5.7-1 shows the high-level architecture used to support identifier association query and response requirements. The Identifier Event Function (IEF) provides the Identifier Caching Function (ICF) with the events necessary to answer the identifier association queries from the IQF. LEAs are able to issue real-time queries to the Identifier Query Function (IQF), which in turn queries the ICF.

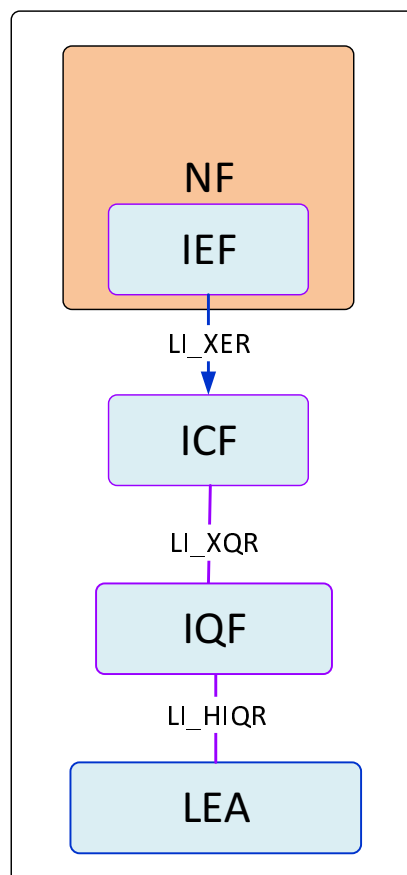

**Figure 5.7-1 High-level identifier retrieval via Query and Response.**

The IQF and ICF shall support the following query types:

- Single query and response.

- Single query and response followed by triggered real-time reporting of any subsequent changes reported to the ICF (see NOTE 2).

Within the present document, only a single ICF for all IEFs is supported.

Within the present document, interfaces and generic functionality for dedicated identifier query and response are defined in this clause, while specific instances of the IEFs are defined within clause 6 and the ICF in clause 7.

For each request over LI\_HIQR, the LEA shall provide a legal warrant/authorisation unique identifier. In addition, depending on the scenario, the LEA needs to provide, the observed identity (temporary or permanent), along with the serving cell identity, tracking area identifier, and time of observation by LEA.

The IQF shall obtain in real-time the identifier associations which match the LEA query from the ICF and provide a response to the LEA over LI\_HIQR.

In some cases, it may not be possible to establish a single unique identifier association given the information provided by the LEA. IQF handling in such a scenario is subject to the authorisation in the warrant and is outside the scope of the present document.

NOTE 1: If the LEA is unable to provide the tracking area associated with an observed temporary identifier this may prevent the CSP from uniquely associating the identifier to the correct UE.

NOTE 2: Single query and response followed by triggered real-time reporting of any subsequent changes detected by the IEF is only applicable to queries based on a permanent identifier where the changes reported are new temporary identifiers to which that permanent identifier has been associated.

NOTE 3: The terms identifier and identity are used interchangeably in clause 5.7. This also applies to the naming of functions like IQF.

## 5.7.2 Functional entities

### 5.7.2.1 Identity Query Function (IQF)

The IQF is the function responsible for receiving and responding to dedicated LEA real-time queries for identifier associations. The IQF is a sub-function of the ADMF.

On receiving a valid query, the IQF shall query the ICF in order to obtain the required mapped identities. The IQF shall be able to support both association from permanent identifiers to temporary identifiers and from temporary identifiers to permanent identifiers.

NOTE 1: Only queries based on applicable subscription permanent identifiers or associated temporary identifiers are supported by the present document. Queries based on ME hardware identifiers or communications services identifiers (e.g. E.164 numbers) are not supported by the IQF.

NOTE 2: A specific query response to the LEA may require both permanent and temporary identifiers to be returned in a single response for a given query. For example, if an LEA queries using a temporary identifier, then it may be necessary to respond with a permanent identifier, plus other associated temporary identifiers in order to fulfil the query.

The IQF shall only support queries that are received from the LEA within the caching duration and shall reject any queries from the LEA which fall outside those time limits.

NOTE 3: It may not always be possible for the CSP to provide an answer due to association information no longer being available in the network. The IQF shall provide support for multiple LEA scenarios. The IQF shall be able to support different query constraints for different LEAs.

NOTE 4: Since IEF event generation and ICF temporary caching applies to all UEs served by the parent NF, any multiple LEA scenarios or differences in requirements are handled by the IQF only and no specific support is provided by IEF or ICF.

The IQF shall support both query and response types as defined in clause 5.7.1.

### 5.7.2.2 Identity Event Function (IEF)

The IEF is the function responsible for observing and detecting identifier association changes within its parent NF and providing those changes in the form of event records to the ICF over LI\_XER.

IEFs may be co-located with POIs but may also be placed in other NFs where the NFs handling identifier association do not otherwise support POI functionality.

The IEF shall be able to provide event records to the ICF when associations are updated. Association events include both allocation or deallocation events for temporary identifiers managed by the IEF's parent NF and for identifier associations which are registered or deregistered in the IEF's parent NF but the identifier allocation is not controlled by that NF.

The IEF shall support activation and deactivation of IEF association reporting capabilities, as controlled by the LICF (proxied by the LIPF) over the LI\_XEM1 interface.

When IEF reporting capabilities are activated, the IEF shall obtain the current allocation and registration state of all UEs known to the parent NF, (where that information has been retained in the NF as part of normal network operations) and send this as a series of allocation/registration events to the ICF.

**NOTE:** The IEF can only report on associations that occurred before activation of the IEF if those associations remain valid for UEs which are still served by the parent NF (some allocations may not be retained by the parent NF). Therefore, not all UE identifier associations may be available at IEF activation (e.g. due to NF or UE mobility) and therefore ICF caching may be incomplete until network reauthentication timers or similar reallocation timers have refreshed all served UEs as part of normal network operation. Such incomplete data will result in no matching identifier responses from the ICF.

When IEF reporting capabilities are deactivated, the IEF shall immediately stop sending event records to the ICF.

### 5.7.2.3 Identity Caching Function (ICF)

The ICF is the LI function responsible for caching of identifier associations provided by the IEF in event records received over the LI\_XER and answering queries from the IQF received over LI\_XQR. The ICF shall support association queries from both temporary identities to permanent identities and from permanent identities to temporary identities.

The ICF shall store identifier associations received from the IEF and hold them indefinitely as active associations until:

- A new association event is received which updates a previous association.
- A disassociation event is received for a stored association.
- A CSP defined maximum age is reached.

Upon receiving a disassociation event or a new association event from the IEF, the ICF shall match any corresponding identifier associations, mark them for deletion and begin the cache time for that association. After being marked for deletion, associations shall be deleted and purged irrecoverably from the ICF once their cache time limit is reached.

**NOTE:** The cache time limit after which automatic deletion should occur is outside the scope of the present document. However, this CSP determined value needs to be no shorter than the maximum allowed query delay (i.e., the time from the identity observation by the LEA to the query reception by the CSP). Otherwise, this value needs to be as short as possible.

The ICF shall support both query and response types as defined in clause 5.7.1. For the on-going triggered response query type, after sending the initial response, the ICF shall send a further response each time the permanent identifier provided in the initial query is associated or de-associated with a temporary identifier until the IQF deprovisions the query in the ICF.

The ICF shall support immediate deletion of identifier associations received in events for one or more IEF(s) when requested to do so by the LICF (proxied by the LIPF) over LI\_XEM1.

# 6 Network layer based interception

## 6.1 General

Clause 6 gives details for the configuration of the high-level LI architecture for network layer based interception. It defines aspects of the LI configuration specific to each network under consideration (e.g. 5G), while aspects concerning services delivered over this network are considered in clause 7.

## 6.2 5G

### 6.2.1 General

Figure 6.2-1 depicts the 5G EPC-anchored LI architecture. The network functions are depicted in grey, while the LI elements are depicted in blue.

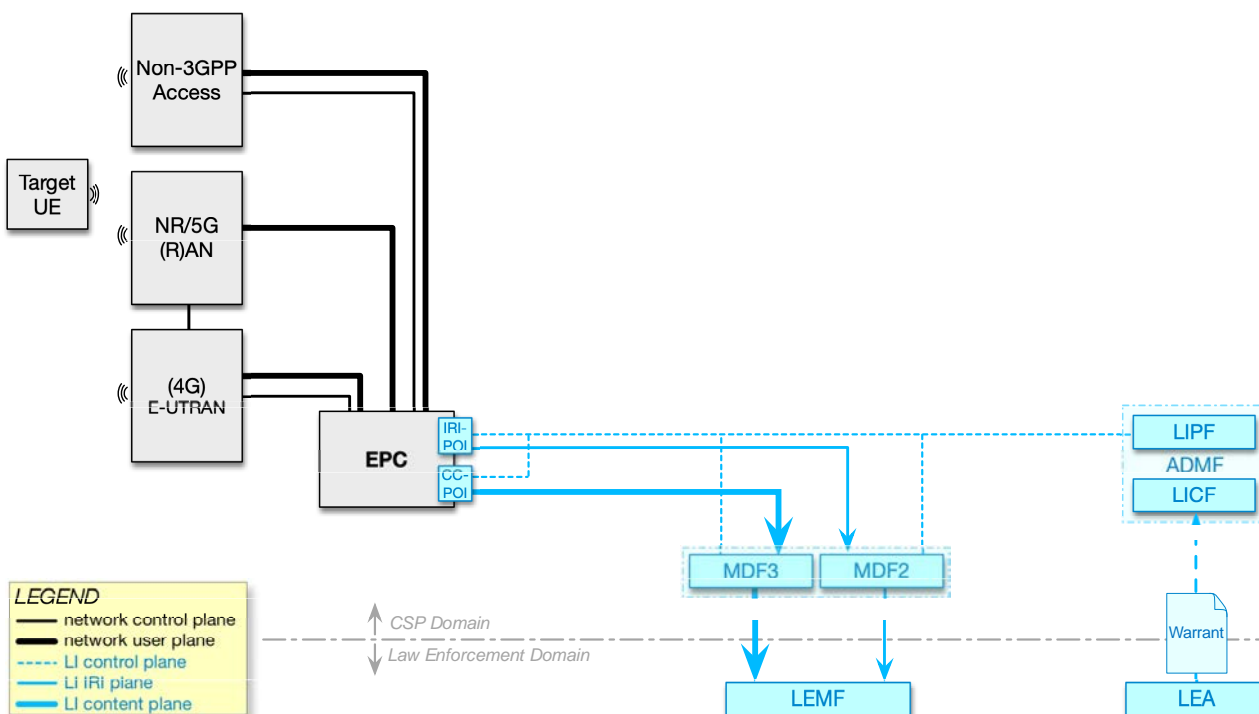
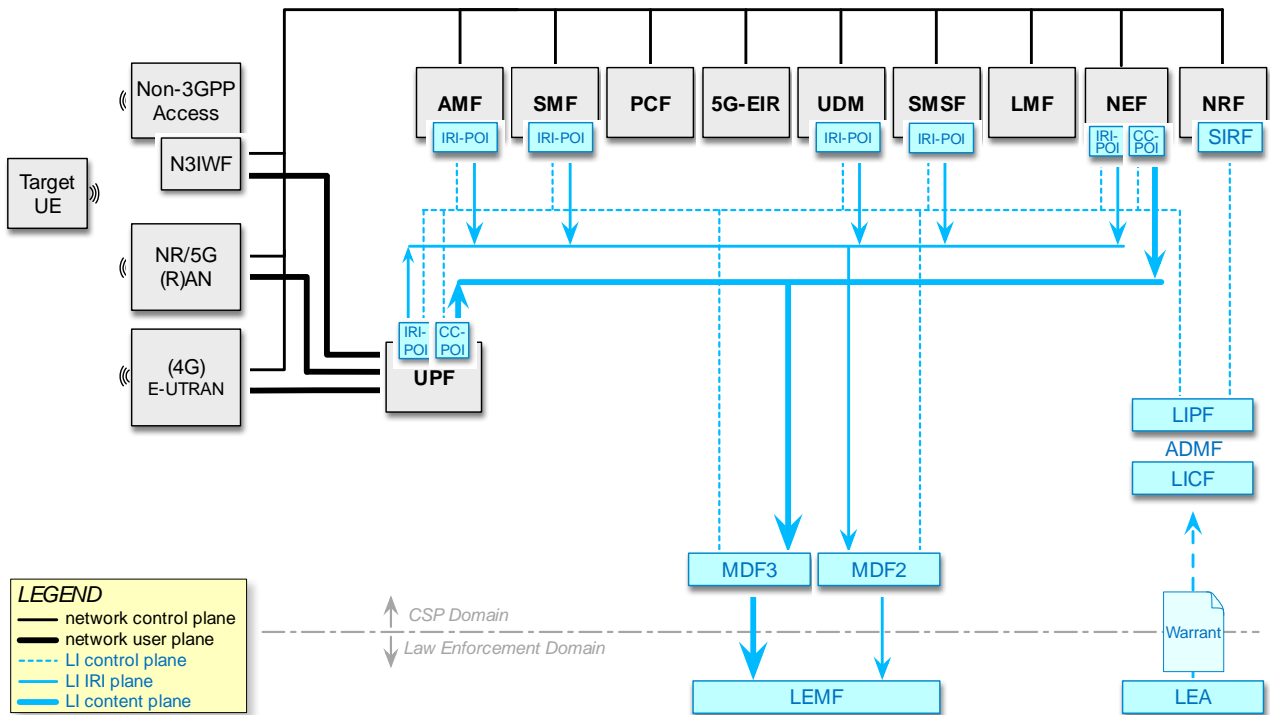

Figure 6.2-1: 5G EPC-anchored LI architecture



Figure 6.2-2 depicts the 5G core-anchored LI architecture. The network functions are depicted in grey, while the LI elements are depicted in blue.



**Figure 6.2-2: 5G core-anchored LI architecture**

NOTE: A CC-POI may also be present in the SMF for roaming NIDD interception, which is not shown in figure 6.2-2.

## 6.2.2 LI at AMF

### 6.2.2.1 Architecture

In the 5GC network, the AMF handles the access and mobility functions as well as provides or facilitates UE location information delivery to other NFs in the course of location-related service operations, such as LCS or Location Reporting. The AMF shall have LI capabilities to generate the target UE's network access, registration, connection management, and location update related xIRI. Extending the generic LI architecture presented in clause 5, figure 6.2-3 below gives a reference point representation of the LI architecture with AMF as a CP NF providing the IRI-POI functions.

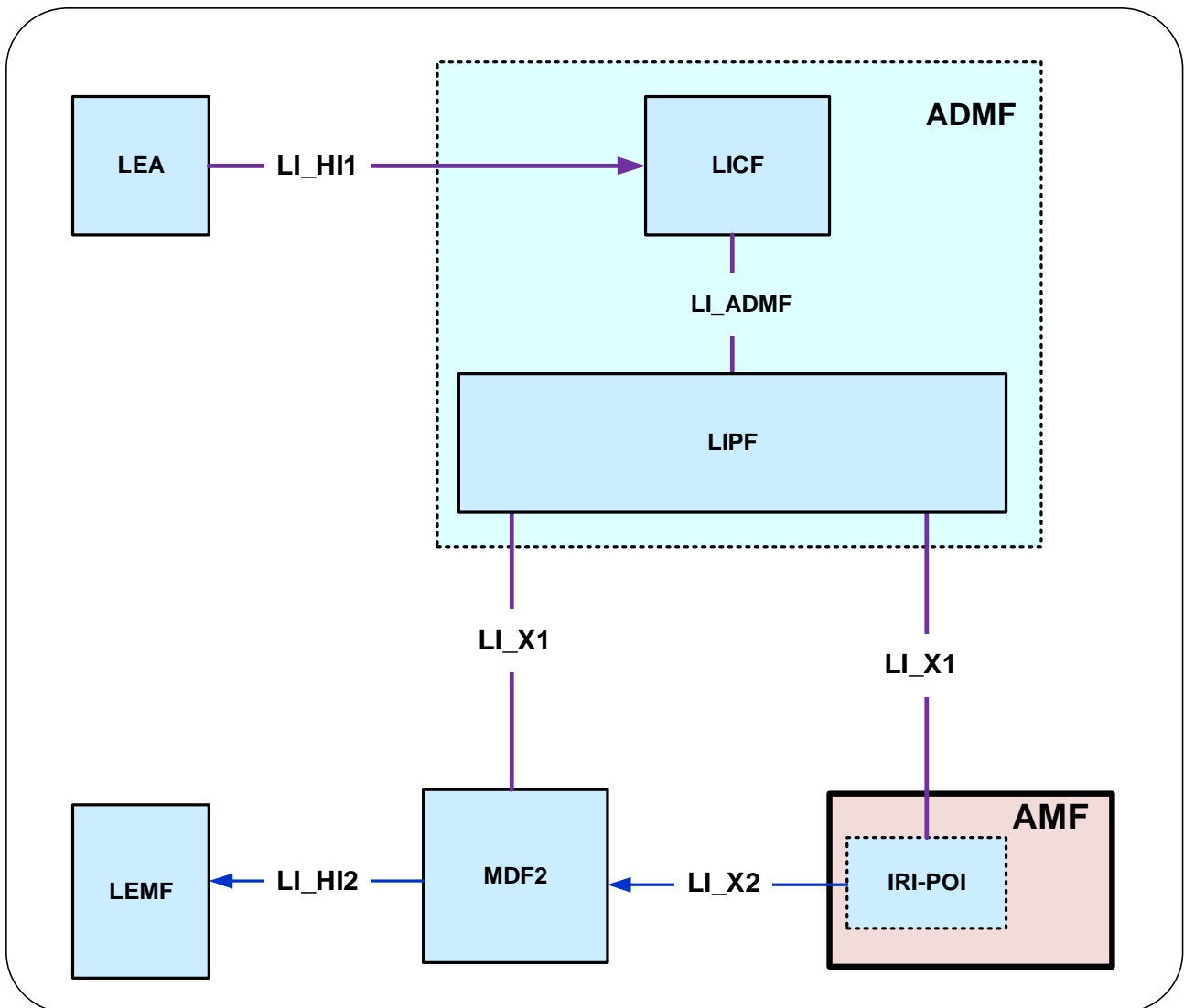

**Figure 6.2-3: LI architecture for LI at AMF**

The LICF present in the ADMF receives the warrant from an LEA, derives the intercept information from the warrant and provides the same to the LIPF.

The LIPF present in the ADMF provisions the IRI-POI (over LI\_X1) present in the AMF and the MDF2. The LIPF may interact with the SIRF (over LI\_SI) present in the NRF to discover the AMFs in the network.

The IRI-POI present in the AMF detects the target UE's access and mobility related functions (network access, registration and connection management), generates and delivers the xIRI to the MDF2 over LI\_X2. The MDF2 delivers the IRI messages as part of the Interception Product to the LEMF over LI\_HI2.

### 6.2.2.2 Target identities

The LIPF present in the ADMF provisions the intercept information associated with the following target identities to the IRI-POI present in the AMF:

- SUPI.
- PEI.
- GPSI.

The interception performed on the above three identities are mutually independent, even though, an xIRI may contain the information about the other identities when available.

### 6.2.2.3 Identity privacy

TS 33.501 [9] defines the ability to prevent the SUPI being exposed over the 5G RAN through the use of SUCI. Where SUPI privacy is implemented by both the UDM and UE, the SUPI is not sent in the clear over the RAN. Therefore, AMF has to rely on the UDM to provide the SUPI as part of the registration procedure as defined in TS 33.501 [9].

If the AMF receives a SUCI from the UE then the AMF shall ensure for every registration (including re-registration) that SUPI has been provided by the UDM to the AMF and that the SUCI to SUPI mapping has been verified as defined in TS 33.501 [9]. This shall be performed regardless of whether the SUPI is a target of interception.

The AMF IRI-POI shall provide both the SUPI and the current SUCI in all applicable events defined in clause 6.2.2.4.

### 6.2.2.4 IRI events

The IRI-POI present in the AMF shall generate xIRI, when it detects the following specific events or information:

- Registration.
- Deregistration.
- Location update.
- Identifier association.
- Start of interception with already registered UE.
- Unsuccessful communication related attempt.
- Positioning info transfer.

NOTE: AMF reporting of UE state changes other than registration or deregistration is not supported in the present document.

The registration xIRI is generated when the IRI-POI present in an AMF detects that a target UE has successfully registered to the 5GS via 3GPP NG-RAN or non-3GPP access. The registration xIRI describes the type of registration performed (e.g. initial registration, periodic registration, registration mobility update) and the access type (e.g. 3GPP, non-3GPP). Unsuccessful registration shall be reported only if the target UE has been successfully authenticated.

The deregistration xIRI is generated when the IRI-POI present in an AMF detects that a target UE has deregistered from the 5GS. The deregistration xIRI shall indicate whether it was a UE-initiated or a network-initiated deregistration.

The location update xIRI is generated each time the IRI-POI present in an AMF detects that the target's UE location is updated due to target UE mobility (e.g. in case of Xn based inter NG-RAN handover) or when the AMF observes target UE location information during some service operation (e.g., LCS, Location Reporting, or emergency services). The generation of such xIRI may be omitted if the updated UE location information is already included in other xIRIs (e.g. mobility registration) provided by the IRI-POI present in the same AMF. If the information in the AMF received over N2 (TS 38.413 [14]) includes one or more cell IDs, then all cell IDs shall be reported to the LEMF whenever location reporting is triggered at the AMF.

The identifier association xIRI is generated each time the IRI-POI in the AMF detects a SUCI or 5G-GUTI allocation change for a SUPI associated with the target UE.

The start of interception with already registered UE xIRI is generated when the IRI-POI present in an AMF detects that interception is activated on the target UE that has already been registered in the 5GS.

When additional warrants are activated on a target UE, MDF2 shall be able to generate and deliver the start of interception with already registered UE related IRI messages to the LEMF associated with the warrants without receiving the corresponding start of interception with already registered UE xIRI.

The unsuccessful communication related attempt xIRI is generated when the IRI-POI present in an AMF detects that a target UE initiated communication procedure (e.g. session establishment, SMS) is rejected or not accepted by the AMF before the proper NF handling the communication attempt itself is involved. The unsuccessful communications related attempt xIRI is also generated when the IRI-POI present in the AMF detects that a PDU session modification request to convert a single access PDU session to a Multi-Access PDU (MA PDU) session is not accepted by the AMF and therefore not forwarded to the SMF.

The IRI-POI in the AMF shall support per target selective activation or deactivation of reporting of identifier association xIRI independently of activation of LI for all other events. When identifier association xIRI only reporting is activated, the IRI-POI in the AMF shall also generate location update xIRI.

The positioning info transfer xIRI is generated when the IRI-POI present in the AMF detects one the the following events:

- network-based or network-assisted positioning requests, responses or reports related to a target UE are being exchanged between LMF and NG-RAN via the AMF.
- UE-based or UE-assisted positioning requests, responses or reports related to a target UE are being exchanged between LMF and the target UE via the AMF.

NOTE: The activation and invocation of the positioning info transfer capability exclusively for LALS is not supported in the current version of the specification. Instead, the capability is invoked whenever any LCS operation (including LALS) is performed on the target.

### 6.2.2.5 Common IRI parameters

The list of xIRI parameters are specified in TS 33.128 [15]. All xIRI shall include the following:

- Target identity.
- Time stamp.
- Location information.
- Correlation information.

### 6.2.2.6 Specific IRI parameters

The list of parameters in each xIRI are defined in TS 33.128 [15]. The following give a summary.

The registration xIRI shall include the following:

- Registration type information.
- Access type information.
- Requested slice information.

The deregistration xIRI shall include the following:

- UE initiated de-registration.
- Access type information.
- Network initiated de-registration.

The location update xIRI shall include the following:

- Location of the target UE (see clause 7.3).

The identifier association xIRI shall include the following:

- Subscription permanent identifier.
- Temporary identifier association (i.e. SUCI or 5G-GUTI).
- Association change type indication.

The start of interception with already registered UE xIRI shall include the following:

- Access type information.
- Requested slice information.

The unsuccessful communication attempt xIRI shall include the following:

- Rejected type of communication attempt.
- Access type information.
- Failure reason.

When the access type is non-3GPP, the IP address used by the UE to reach the N3A Entity shall be reported. The port shall also be reported if available.

### 6.2.2.7 Network topologies

The AMF shall provide the IRI-POI functions in the following network topology cases:

- Non-roaming case.
- Roaming case, in VPLMN.
- Roaming case, in HPLMN for non-3GPP access.

In a roaming case, it is possible that the target UE may use non-3GPP access with the N3A Entity present in the HPLMN.

## 6.2.2A Identifier Reporting for AMF

### 6.2.2A.1 General

The AMF shall provide IEF capabilities. The IEF present in the AMF shall support LI\_XEM1 interface and upon activation shall provide IEF events to the ICF over LI\_XER interface.

The IEF shall not generate events prior to UEs being successfully registered by the AMF onto the network.

### 6.2.2A.2 IEF Events

The IEF present in the AMF shall generate report records, when it detects the following specific events or information for any UE:

- Association of a 5G-GUTI to a SUPI (this may also include SUCI to SUPI association).
- De-association of a 5G-GUTI from a SUPI.

NOTE1: The de-association event is only generated if a new 5G-GUTI is not allocated to a SUPI to update a previous association (e.g. at inter-AMF handover).

NOTE 2: For SUCIs seen during registration, they shall only be reported if UE registration is successfully completed.

The association event shall be generated by the IEF in the AMF whenever the AMF initiates any action or procedure for which a new allocated 5G-GUTI is sent to the UE regardless of whether the action or procedure is completed successfully.

### 6.2.2A.3 IEF Event parameters

The list of event parameters is specified in TS 33.128 [15]. Each event shall include at the minimum the following information:

- Subscription permanent identifier.
- Observed temporary identifier(s).
- Cell identity (see clause 7.3).
- Time stamp of event.

- AMF identifier (including Region and Set Identifiers).
- Tracking area identifier.
- Registration area (including tracking area identifier list).

The following additional information shall be included if it is available in the AMF when the event is reported to the ICF:

- Permanent equipment identifier.

#### 6.2.2A.4 Network topologies

Since the IEF generates events independently of network topology for individual service usage UEs, no specific network topology handling is provided by the IEF. The IQF shall be responsible for handling any network topology requirements that may be applied by the LEA in an individual warrant.

### 6.2.3 LI for SMF/UPF

#### 6.2.3.1 Architecture

In the 5GC network, user plane functions are separated from the control plane functions. The SMF that handles control plane actions (e.g. establishing, modifying, deleting) for the PDU sessions shall include an IRI-POI that has the LI capability to generate the related xIRI. The UPF that handles the user plane data shall include a CC-POI that has the capability to duplicate the user plane packets from the PDU sessions based on the interception rules received from the SMF. Figure 6.2-4 shows the LI architecture for SMF/UPF based interception.

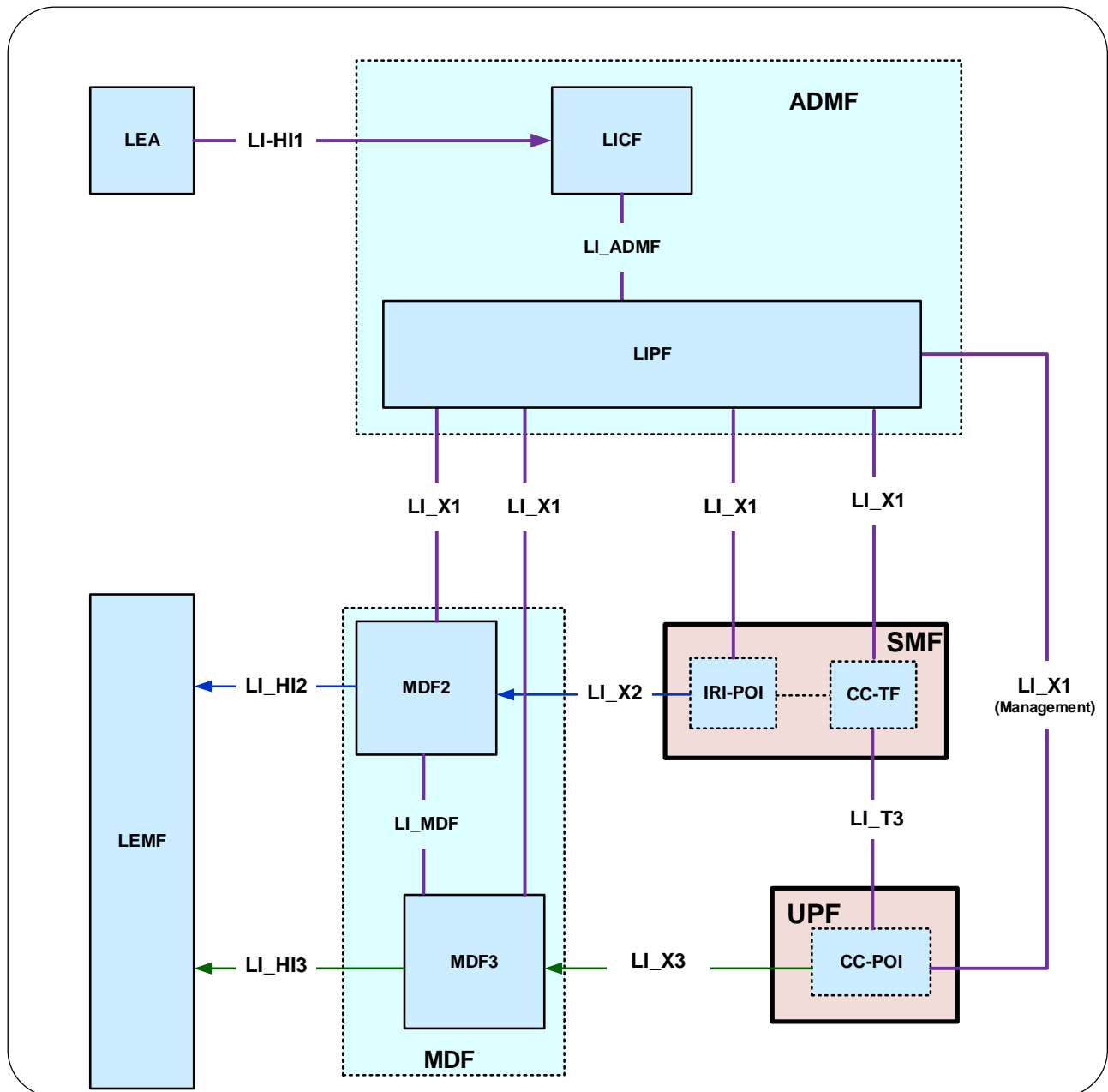

Figure 6.2-4: LI architecture showing LI at SMF/UPF

The LICF present in the ADMF receives the warrant from an LEA, derives the intercept information from the warrant and provides it to the LIPF.

The LIPF present in the ADMF provisions IRI-POI (present in the SMF), MDF2 and MDF3 over the LI\_X1 interfaces. To enable the interception of the target's user plane packets (e.g. when the warrant requires the interception of communication contents), the CC-TF present in the SMF is also provisioned with the intercept data.

NOTE 1: The IRI-POI and CC-TF represented in figure 6.2-4 are logical functions and require correlation information be shared between them; they may be handled by the same process within the SMF.

The LIPF may interact with the SIRF (over LI\_SI) present in the NRF to discover the SMFs and UPFs in the network. The IRI-POI present in the SMF detects the PDU session establishment, modification, and deletion related events, generates and delivers the related xIRI to the MDF2 over LI\_X2. The MDF2 delivers the IRI messages to the LEMF over LI\_HI2.

When interception of communication contents is required, the CC-TF present in the SMF sends a trigger to the CC-POI present in the UPF over the LI\_T3 interface. The CC-POI in the UPF shall present itself as the same CC-POI to all the

CC-TFs in the same SMF set, such that a CC-TF is capable of modifying or deactivating a task activated/modified in the CC-POI by a different CC-TF in the same SMF set.

The trigger sent from the CC-TF to CC-POI includes the following information:

- User plane packet detection rules.
- Target identity.
- Correlation information.
- MDF3 address.

NOTE 2: When LI\_T3 is used, the LI\_X1 between LIPF and CC-POI present in the UPF is used to monitor the user plane data.

The CC-POI present in the UPF generates the xCC from the user plane packets and delivers the xCC (that includes the correlation number and the target identity) to the MDF3. The MDF3 delivers the CC to the LEMF over LI\_HI3.

A warrant that does not require the interception of communication contents, may require IRI messages that have to be derived from the user plane packets. To support the generation of related xIRI (i.e. that requires access to the user plane packets), the present document supports two implementation approaches as described in clause 7.12.2. When approach 1 from clause 7.12.2 is used, the IRI-POI in the UPF shall present itself as the same IRI-POI to all the IRI-TFs in the same SMF set, such that an IRI-TF is capable of modifying or deactivating a task activated/modified in the IRI-POI by a different IRI-TF in the same SMF set.

Clause 8.6.2 defines a CC-PAG (CC-POI Aggregator) as an architectural extension option that is located between the MDF3 and CC-POI and performs the function of aggregating the xCC from different CC-POIs towards the MDF3.

### 6.2.3.2 Target identities

The LIPF provisions the intercept related information associated with the following target identities to the IRI-POI present in the SMF:

- SUPI.
- PEI.
- GPSI.

The interception performed on the above three identities are mutually independent, even though, an xIRI may contain the information about the other identities when available.

### 6.2.3.3 IRI events

The IRI-POI present in the SMF shall generate xIRI, when it detects the following specific events or information:

- PDU session establishment.
- PDU session modification.
- PDU session release.
- Start of interception with an established PDU session.

The PDU session establishment xIRI is generated when the IRI-POI present in the SMF detects that a PDU session has been established for the target UE.

The PDU session modification xIRI is generated when the IRI-POI present in the SMF detects that a PDU session is modified for the target UE.

The PDU session release xIRI is generated when the IRI-POI present in the SMF detects that a PDU session is released for the target UE.

The start of interception with an established PDU session xIRI is generated when the IRI-POI present in a SMF detects that interception is activated on the target UE that has an already established PDU session in the 5GS. When a target UE



has multiple PDU sessions, this xIRI shall be sent for each PDU session with a different value of correlation information.

When additional warrants are activated on a target UE, MDF2 shall be able to generate and deliver the start of interception with an established PDU session related IRI messages to the LEMF associated with the warrants without receiving the corresponding start of interception with an established PDU session xIRI.

When the warrant requires the packet header information reporting, the following xIRI shall be generated:

- Packet header information report (see clause 7.12.2).

The generation of packet header information reporting can be done by either the IRI-POI present in the UPF or the MDF2.

#### 6.2.3.4 Common IRI parameters

The list of xIRI parameters are specified in TS 33.128 [15]. Each xIRI shall include at the minimum the following information:

- Target identity.
- Time stamp.
- Correlation information.
- Location information.
- Session related information.

#### 6.2.3.5 Specific IRI parameters

The parameters in each xIRI are defined in TS 33.128 [15].

#### 6.2.3.6 Network topologies

The SMF shall provide the IRI-POI functions in the following network topology cases:

- Non-roaming case.
- Roaming case, in VPLMN.
- Roaming case, in HPLMN.
- Non-3GPP access case, in the PLMN where N3A Entity resides.

When the target UE has multiple PDU sessions active, the generation and delivery of xCC for each PDU session shall be done independently, each with separate correlation information.

When a target UE's PDU session involves multiple Data Network (DN) connections (i.e. multiple connections to the same DN as described in clause A.3 of the present document), the generation and delivery of xCC shall be done in such a way that:

- All applicable user plane packets are captured and delivered.
- Duplicate delivery of CC is suppressed to the extent possible.
- Each user plane packet is delivered with the associated DN Access Identifier (DNAI).

A PDU session may involve more than one UPFs. In that case, the CC-TF present in the SMF shall determine which UPF(s) is (are) more suitable to provide the CC-POI functions adhering to the above requirements. Furthermore, independent of which UPF is used to generate the xCC, the CC delivered from the MDF3 shall be correlated to the IRI messages related to the PDU session.

### 6.2.3.7 Multi-Access PDU (MA PDU) Session Specific

The IRI-POI present in the SMF shall generate xIRI, for MA PDU sessions when it detects events or information as in clause 6.2.3.3, with the following clarifications.

The PDU session establishment xIRI:

- When a UE request for an MA PDU session is received at the SMF (for one or more access types).
- When a UE request for a single access PDU session is received at the SMF with an upgrade indicator to an MA PDU and the SMF chooses to establish an MA PDU session.

The PDU session modification xIRI:

- When an MA PDU Session is modified by releasing or adding an access type.
- When a UE request for a mid-session upgrade to MA PDU session is received at the SMF.

The PDU session release xIRI:

- When the entire PDU session is released.

Each user plane packet of the MA PDU session should be able to be associated to the access type.

6.2.3.8 LI state transfers in SMF sets

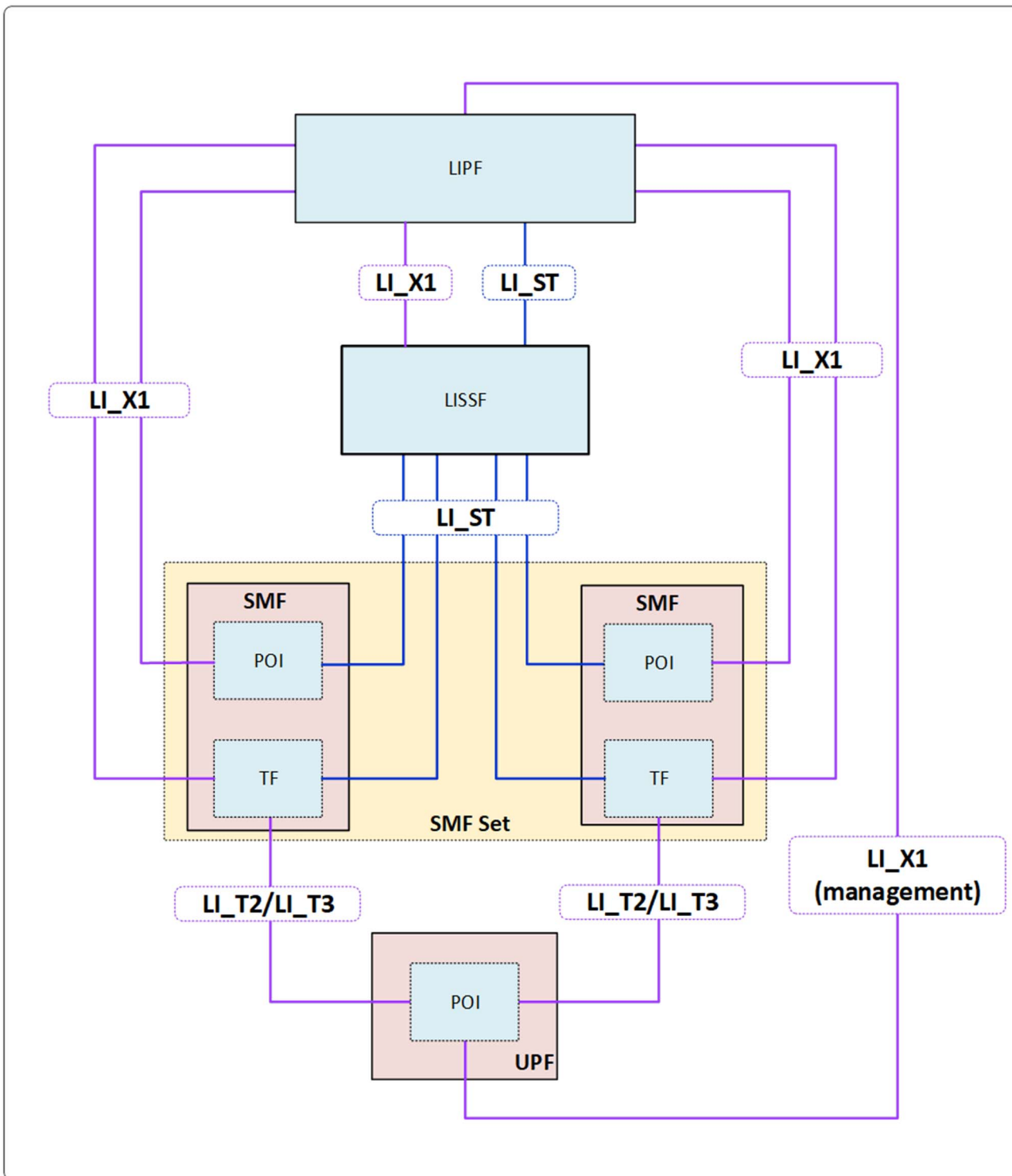

**Figure 6.2-4A: LI architecture diagram for SMF/UPF interception when using SMF sets and LISSF**

If an SMF belongs to an SMF set, then the TF present in the SMF shall have the ability to modify or stop the interceptions in the POIs present in the UPF irrespective of which TF present in an SMF from that SMF set had previously initiated the interception. A TF in one SMF of an SMF set may initiate the interception at a POI present in the UPF, the TF present in another SMF of the SMF set may make changes to the interception in that POI, and a TF in a different SMF of the SMF set may stop the interception in that POI.

In order to allow the TFs present in different SMFs of an SMF set to manage the interceptions at the POI present in an UPF, a new LI function referred to as LI State Storage Function (LISSF) is introduced. The TF that initiates the

interception at a POI present in the UPF stores the related necessary information (e.g. correlation information) in case a different TF has to manage the interception at that POI. This necessary related information is referred to as LI state information (see TS 33.128 [15] for the details).

If an SMF belongs to an SMF set, then the POI present in the SMF shall have the ability to continue the interception using the same correlation information or stop the interception even when the SMF that manages the PDU session changes.

In order to allow the POIs present in different SMFs of an SMF set to continue the interception by maintaining a continuity, the LISSF mentioned above is used by storing the LI state information. When required, the POI present in the SMF of an SMF set stores the LI state information in the LISSF. The POI present in another SMF of the same SMF can retrieve the LI state information from that LISSF to provide a continued interception.

When an SMF in an SMF set requests SM context information related to a target from a UDSF or receives SM context information from another SMF, the TF and POI within the SMF shall retrieve also the relevant LI state information from the shared LISSF.

If the implementation of the SMF set does not ensure that active SM contexts are always present in some SMF of the SMF set, the TF shall also retrieve the relevant LI state information when an existing task is deactivated by the LIPF.

NOTE: The race conditions between the LI\_X1, LI\_ST operations, and network events are possible and need to be accounted for in the implementation.

### 6.2.3.9 Interface LI\_ST

LI\_ST is an interface between the LISSF and the LIPF and between the LISSF and other LI functions. It is used for transferring LI state information. The LI functions may request, store or erase LI state information from the LISSF using this interface. LI functions need to be authorized by the LIPF to have access to a specific instance of the LISSF before using the LI\_ST interface.

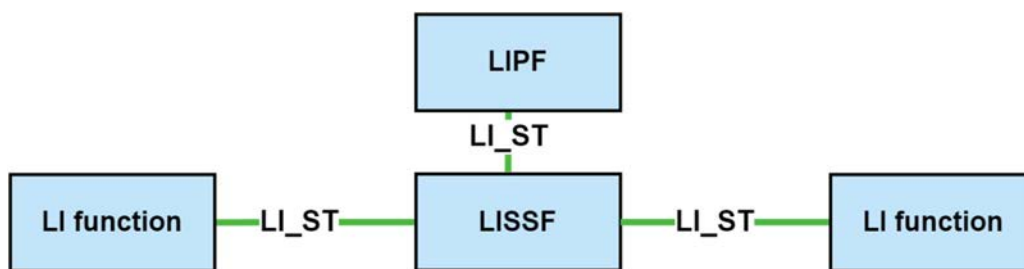

Figure 6.2-4B: Use of the LI\_ST interface in the LI architecture.

## 6.2.4 LI at UDM for 5G

In 5G packet core network, the UDM provides the unified data management for UE. The UDM shall have LI capabilities to generate the target UE's service area registration related xIRI. See clause 7.2.2 for the details.

## 6.2.5 LI at SMSF

### 6.2.5.1 Architecture

In the 5GC network, the SMSF provides functionalities to support the SMS over NAS. The SMSF shall have LI capabilities to generate xIRIs when SMS related to the target UE are handled. Extending the generic LI architecture presented in clause 5, figure 6.2-5 below gives a reference point representation of the LI architecture with SMSF as a CP NF providing the IRI-POI functions.

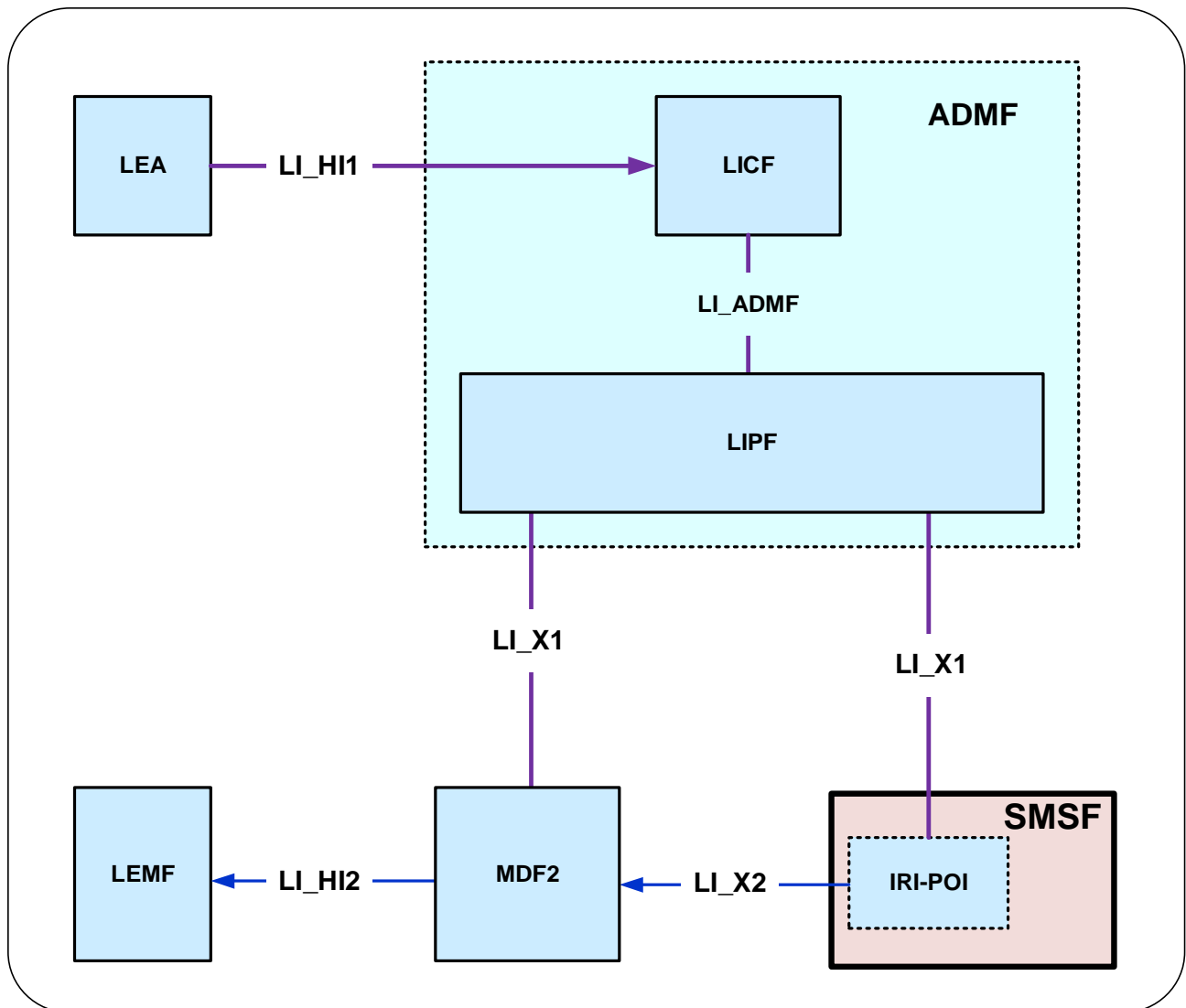

**Figure 6.2-5: LI architecture for LI at SMSF**

The LICF present in the ADMF receives the warrant from an LEA, derives the intercept information from the warrant and provides the same to the LIPF.

The LIPF present in the ADMF provisions the IRI-POI present in the SMSF and the MDF2 over LI\_X1 interfaces. The LIPF may interact with the SIRF (over LI\_SI) present in the NRF to discover the SMSFs in the network.

The IRI-POI present in the SMSF detects the target UE's SMS, generates and delivers the xIRI to the MDF2 over LI\_X2. The xIRI will contain the SMS payload. The MDF2 shall support the capability to deliver the IRI messages including the SMS payload as part of the Interception Product to the LEMF over LI\_HI2.

National regulations may require that the MDF2 remove information regarded as content from the payload in case of an IRI only warrant.

### 6.2.5.2 Target identities

The LIPF present in the ADMF provisions the intercept information associated with the following target identities to the IRI-POI present in the SMSF:

- SUPI.
- PEI.
- GPSI.

The interception performed on the above three identities are mutually independent, even though, an xIRI may contain the information about the other identities when available.

### 6.2.5.3 IRI events

The IRI-POI present in the SMSF shall generate xIRI, when it detects the following specific events or information:

- SMS message.

The SMS message xIRI is generated when the IRI-POI present in an SMSF detects that an SMS message for the target UE is handled.

### 6.2.5.4 Common IRI parameters

The list of xIRI parameters are specified in TS 33.128 [15]. The xIRIs shall include at the minimum the following information:

- Target identity.
- Time stamp.
- Location information.
- SMS message direction (mobile originated, mobile terminated).
- SMS message payload.

### 6.2.5.5 Specific IRI parameters

The parameters in each xIRI are defined in TS 33.128 [15].

### 6.2.5.6 Network topologies

The SMSF shall provide the IRI-POI functions in the following network topology cases:

- Non-roaming case.
- Roaming case, in VPLMN.

NOTE: SMS message delivery over non-3GPP access with N3A Entity in the HPLMN is considered a non-roaming case.

## 6.2.6 LI support at NRF

### 6.2.6.1 Architecture

In 5G, network functions that support SBA register with the NRF after instantiation. The NRF thus provides the network repository functions and is aware of all the NFs that have been instantiated. The present document refers to this as system information.

The SIRF present in the NRF provides the system information to LIPF present in the ADMF, in order for the LIPF to establish which NFs (and therefore POIs) are applicable to a specific target user's services. LI function service discovery is described in clause 5.5.

An architecture diagram depicting this LI at NRF is shown in figure 6.2-6 below.

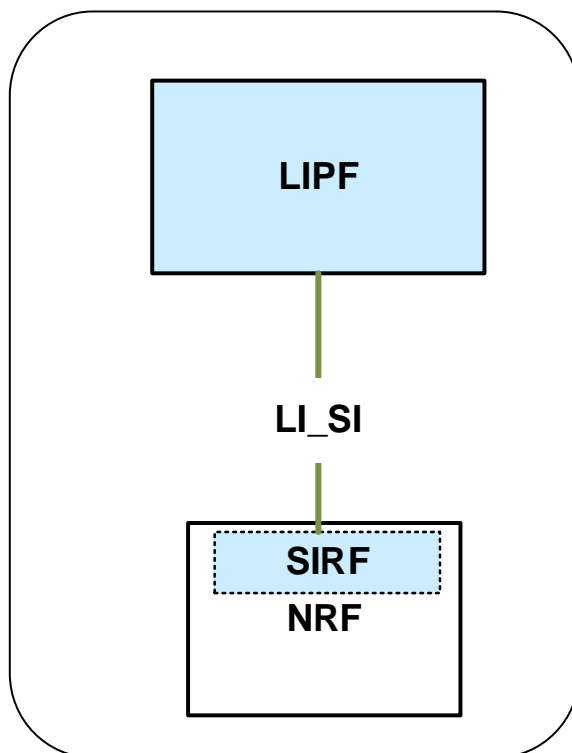

**Figure 6.2-6: LI Architecture depicting NRF as an SIRF**

Figure 6.2-6 shows the architecture illustrating the SIRF functions within the NRF.

The LIPF present in the ADMF interacts with the SIRF (over LI\_SI) present in the NRF to obtain the system information.

#### 6.2.6.2 LI\_SI notifications

The SIRF present in the NRF shall generate notifications over LI\_SI when the SIRF detects the following specific events or information:

- NF service registration.
- NF service update.
- NF service deregistration.
- NF service chain change.

The NF service chain change notification shall be generated whenever an NF is added to or removed from a service chain in response to NF discovery and selection events.

#### 6.2.6.3 LI\_SI parameters

The notifications reported over LI\_SI by the SIRF shall include the following information elements:

- Event type (as defined in clause 6.2.6.2).
- NF details, including appropriate information elements defined in TS 23.501 [2] clause 6.2.6.

## 6.2.7 External data storage

### 6.2.7.1 UDSF or UDR

The UDSF or UDR as defined in TS 23.501 [2] are used to externally store data relating to one or more NFs, separating the compute and storage elements of an NF. Where the NF contains a POI the following restrictions on the use of the UDSF/UDR shall apply:

- The UDSF/UDR shall be subject to the same location, geographic, security and other physical environment constraints as the NF POI for which it is storing data.
- No LI specific POI data (e.g. target list) shall be stored in the UDSF/UDR unless storage is directly under the control of the POI within the NF.
- LI data stored in a UDSF/UDR shall only be accessible by the specific individual POI for which the UDSF/UDR is storing data and that data shall not be shared between POIs unless specifically authorised by the LICF within the ADMF.
- By default, LI data shall not be stored in a UDSF/UDR which is shared by multiple NFs unless specifically authorised by the LICF.
- Any storage of LI data outside of the POI in the UDSF/UDR shall be auditable by the LICF.
- The interface between the POI/NF and the UDSF/UDR shall be protected such that an attacker cannot identify targeted users based on observation of this interface. (i.e. access to the UDSF/UDR shall be identical for both intercepted and non-intercepted user communications).
- The use and placement of a UDSF/UDR within an NF/POI design shall not introduce additional interception delay compared with non-separated compute and storage.
- Where the POI requires access to NF data that is stored in the UDSF/UDR, non-LI network functions and processes or non-LI authorised personnel shall not be able to detect POI access to that data in the UDSF/UDR.
- The POI and LICF/MDF shall be responsible for managing encryption of LI data stored in the UDSF/UDR for the POI in addition to any default encryption applied by the NF.

The above requirements shall apply when the UDSF/UDR provide data storage for TF/NF.

### 6.2.7.2 LI State Storage Function (LISSF)

The LISSF is a function that makes it possible for other LI functions to share information with each other. There can be multiple instances of the LISSF in the network being handled by the same ADMF. The LISSF can be implemented as a separate function or within the ADMF. The LISSF may be used to transfer LI state information between LI functions. The following restrictions on the use of the LISSF shall apply:

- The LISSF shall be subject to the same location, geographic, security and other physical environment constraints as the LI functions for which it is storing data.
- LI state information stored in an LISSF shall only be accessible by the LI functions specifically authorised by the LICF.
- Other than the time required to acquire the LI state information, the use and placement of an LISSF within the LI architecture shall not introduce additional delay.
- The LISSF shall be directly under the control of the ADMF, and it shall be directly accessible and auditable by the LICF.

## 6.3 EPC

### 6.3.1 General

The present document specifies three options for EPC interception capabilities:



- Option A. Perform LI on the events specified in the current document in clauses 6.3.2.3.1, 6.3.3.3 and 6.3.4.3 using the capabilities specified below for stage 2 and in TS 33.128 [15] for stage 3.
- Option B. Perform LI on the events specified in TS 33.107 [11] clause 12 and clause 18.2.4 using the capabilities specified below in the present document for stage 2 and in TS 33.128 [15] for stage 3.
- Option C. Use TS 33.107 [11] and TS 33.108 [21] natively as defined in those documents.

For implementations that include EPS/5GS interworking, Option A shall be used.

For virtualised 4G implementations from Release 15 onwards (including combined 4G / 5G scenarios), 4G shall be virtualised based on the architecture in clause 5.6. For such implementations the LI architecture for 4G / LTE shall be implemented using an ADMF as defined in the present document (including LIPF and LICF split). However, equivalent reference points as specified in TS 33.107 [11] shall be used where appropriate (e.g. X2 is equivalent to LI\_X2 in the present document and MDF is equivalent to MF/DF). Security and audit requirements as defined in clause 8 of the present document shall be applied to such 4G scenarios.

## 6.3.2 LI at the MME

### 6.3.2.1 Architecture

In the EPC network, the MME handles the mobility management and connection management as specified in TS 23.401 [22]. The MME shall have LI capabilities to generate the target UE's network access, registration and connection management related xIRI. Extending the generic LI architecture presented in clause 5, figure 6.3-1 below gives a reference point representation of the LI architecture with MME as a CP Network Element providing the IRI-POI functions.

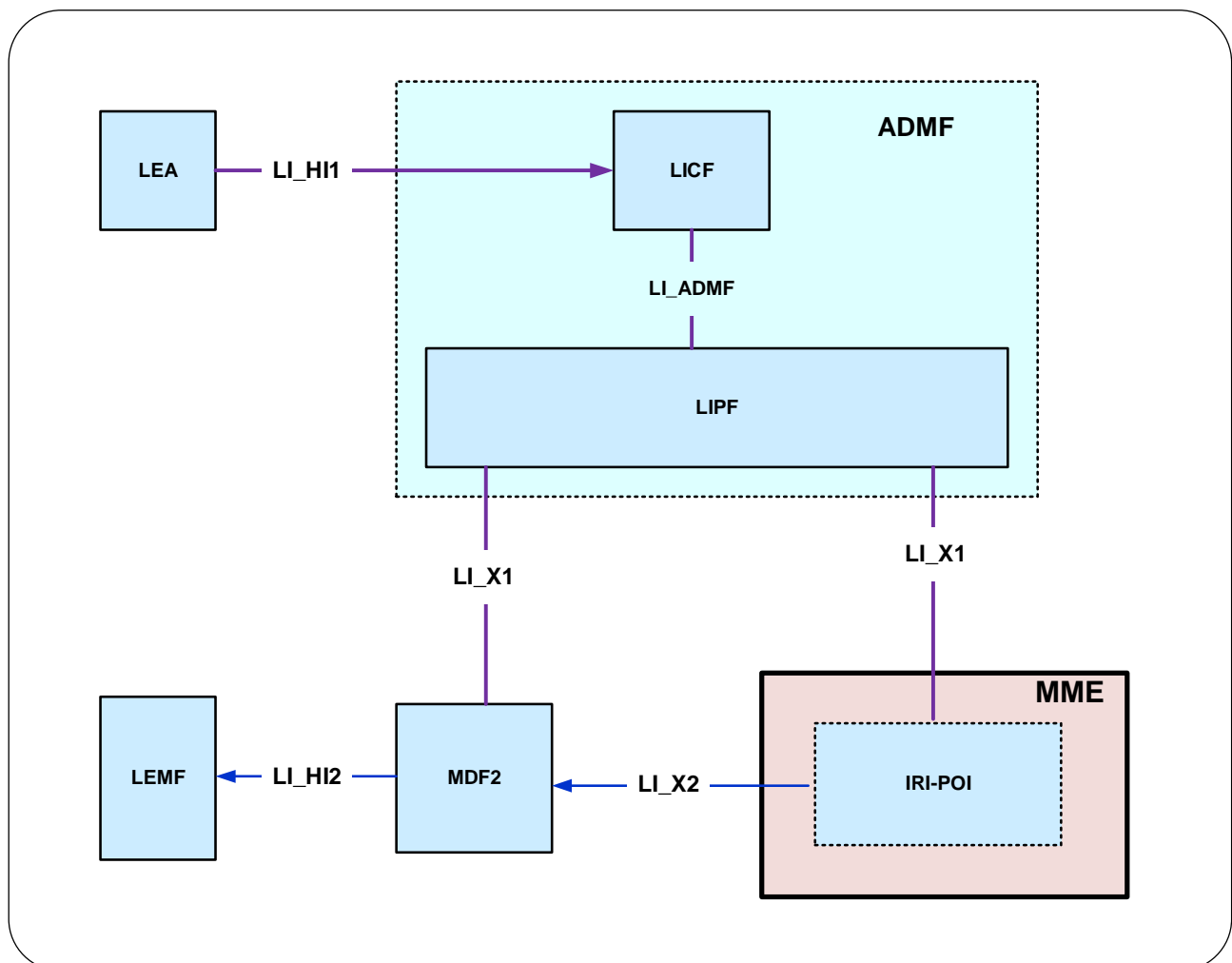

Figure 6.3-1: LI architecture for LI at MME

The LICF present in the ADMF receives the warrant from an LEA, derives the intercept information from the warrant and provides the same to the LIPF.

The LIPF present in the ADMF provisions the IRI-POI (over LI\_X1) present in the MME and the MDF2.

The IRI-POI present in the MME detects the target UE's access and mobility related functions (network access, registration and connection management), generates and delivers the xIRI to the MDF2 over LI\_X2. The MDF2 delivers the IRI messages as part of the Interception Product to the LEMF over LI\_HI2.

### 6.3.2.2 Target identities

The LIPF provisions the IRI-POI present in the MME with the following target identities:

- IMSI.
- MSISDN.
- IMEI.

The interception performed on the above three identities are mutually independent, even though, an xIRI may contain the information about the other identities when available.

### 6.3.2.3 IRI events

#### 6.3.2.3.1 Option A

The IRI-POI present in the MME shall generate xIRI, when it detects the following specific events or information:

- Attach.
- Detach.
- Tracking Area/EPS Location Update.
- Start of interception with EPS attached UE.
- Unsuccessful communication related attempt.
- Identifier association.
- Positioning info transfer.

The attach xIRI is generated when the IRI-POI present in an MME detects that a target UE has performed an E-UTRAN attach procedure including via a HeNB. The attach xIRI describes the type of attach performed. Unsuccessful registration shall be reported only if the target UE has been successfully authenticated.

The detach xIRI is generated when the IRI-POI present in an MME detects that a target UE has detached from the EPS including via a HeNB. The detach xIRI shall indicate whether it was a UE-initiated or a network-initiated detach.

The tracking area/EPS location update xIRI is generated each time the IRI-POI present in an MME detects that the target UE location is updated due to target UE mobility (e.g. in case of X2 based handover, S1 based handover) or when the MME observes target UE location information during some service operation (e.g., periodic Tracking Area Update, UE triggered Service Request). If the information in the MME received over S1 (TS 36.413 [14]) includes one or more cell IDs, then all cell IDs shall be reported to the LEMF whenever location reporting is triggered at the MME.

The start of interception with EPS attached UE xIRI is generated when the IRI-POI present in an MME detects that interception is activated on a target UE that is already attached to the EPS. If there are multiple PDN connections active for the target, then a start of interception with EPS attached UE xIRI is generated for each of them.

When additional warrants are activated on a target UE, MDF2 shall be able to generate and deliver the start of interception with E-UTRAN attached UE related IRI messages to the LEMF associated with the warrants without receiving the corresponding start of interception with already registered UE xIRI.

The unsuccessful communication related attempt xIRI is generated when the IRI-POI present in an MME detects that a target UE initiated communication procedure (e.g. service request, SMS) is rejected or not accepted by the MME before the proper NF handling the communication attempt itself is involved.

The identifier association xIRI is generated each time the IRI-POI in the MME detects a GUTI allocation change for an IMSI associated with the target UE.

The IRI-POI in the MME shall support per target selective activation or deactivation of reporting of only identifier association xIRI independently of activation of LI for all other events. When identifier association xIRI only reporting is activated, the IRI-POI in the MME shall also generate Tracking Area/EPS Location Update xIRI.

The positioning info transfer xIRI is generated when the IRI-POI present in the MME detects one the following events:

- network-based or network-assisted positioning requests, responses or reports related to a target UE are being exchanged between E-SMSC and eNB via the MME.
- UE-based or UE-assisted positioning requests, responses or reports related to a target UE are being exchanged between E-SMLC and the target UE via the MME.

NOTE: The activation and invocation of the positioning info transfer capability exclusively for LALS is not supported in the current version of the specification. Instead, the capability is invoked whenever any LCS operation (including LALS) is performed on the target.

#### 6.3.2.3.2 Option B

The IRI-POI present in the MME shall generate xIRI, when it detects the applicable events specified in TS 33.107 [11].

In addition to the events specified in TS 33.107 [11] the MME shall generate xIRI, when it detects the following additional event:

- Identifier association.

The identifier association xIRI is generated each time the IRI-POI in the MME detects a GUTI allocation change for an IMSI associated with the target UE.

The IRI-POI in the MME shall support per target selective activation or deactivation of reporting of only identifier association xIRI independently of activation of LI for all other events. When identifier association xIRI only reporting is activated, the IRI-POI in the MME shall also generate Tracking Area/EPS Location Update xIRI.

#### 6.3.2.4 Common IRI parameters

The list of xIRI parameters are specified in TS 33.128 [15]. All xIRI shall include the following:

- Target identity.
- Time stamp.
- Location information.
- Correlation information.

#### 6.3.2.5 Specific IRI parameters

##### 6.3.2.5.1 Option A

The list of parameters in each xIRI are defined in TS 33.128 [15]. The following give a summary.

The attach xIRI shall include the following:

- Attach type information.
- Access type information.
- HeNB information.

The detach xIRI shall include the following:

- Detach Direction.
- Detach type information.
- HeNB information.

The tracking area/EPS location update xIRI shall include the following:

- Location of the target (see clause 7.3).
- HeNB information.

The start of interception with EPS attached UE xIRI shall include the following:

- Attach type information.
- Access type information.
- PDN connection information.

The unsuccessful communication attempt xIRI shall include the following:

- Rejected type of communication attempt.
- Access type information.
- Failure reason.

The identifier association xIRI shall include the following:

- IMSI.
- IMEI.
- Temporary identifier association (i.e. GUTI).
- Association change type indication.

#### 6.3.2.5.2 Option B

The list of parameters in each xIRI are defined in TS 33.128 [15], for events which are imported from TS 33.107 [11] clause 12.2.1.2.

The identifier association xIRI shall include the following:

- IMSI.
- IMEI.
- Temporary identifier association (i.e. GUTI).
- Association change type indication.

#### 6.3.2.6 Network topologies

The MME shall provide the IRI-POI functions in the following network topology cases:

- Non-roaming case.
- Roaming case, in VPLMN.

## 6.3.3 LI at SGW/PGW

### 6.3.3.1 Architecture

#### 6.3.3.1.1 General

In the EPC network, the SGW is the gateway which terminates the user plane interface as specified in TS 23.401 [22]. The PGW is the gateway which terminates the SGi interface towards the PDN as specified in TS 23.401 [22]. Additionally, the PGW is the user plane anchor for mobility between 3GPP access and non-3GPP access as specified in TS 23.402 [23].

NOTE : The present document supports LI for non-3GPP accesses connected to EPC using GTP-based S2a or GTP-based S2b as specified by TS 23.402 [23]. Other scenarios are covered by TS 33.107 [11].

The SGW and PGW shall include an IRI-POI that has the LI capabilities to generate the target UE's bearer related and a CC-POI that has the LI capabilities to duplicate the user plane packets from the EPS bearers related to a target UE.

As defined in TS 23.214 [75], the SGW and PGW may have separated control plane and user plane functions (CUPS). The control plane (CP) functions (SGW-C and PGW-C) provide the traffic forwarding rules (referred to as Forward Action Rules in TS 23.214 [75]) to the user plane (UP) functions (SGW-U and PGW-U). The UP functions forward the user plane traffic as per the Forward Action Rules.

In the following clauses, EPS architecture that does not separate the control plane and user plane functions of the SGW/PGW is referred to as non-CUPS EPS.

The LI architecture for non-CUPS EPS is defined in clause 6.3.3.1.2. For non-CUPS EPS architecture, the SGW and PGW function as both CP Entities and the UP Entities.

The LI architecture for CUPS EPS is defined in clause 6.3.3.1.3. For CUPS EPS architecture:

- The CP Entities are the SGW-C and the PGW-C.
- The UP Entities are the SGW-U and the PGW-U.

When CUPS architecture is used, unless otherwise specified, the term SGW/PGW refers to both the SGW-U/PGW-U and the SGW-C/PGW-C.

When CUPS architecture is used:

- The LI functions present in the SGW-C/PGW-C are:
  - The IRI-POI.
  - The IRI-TF.
  - The CC-TF.
- The LI functions present in the SGW-U/PGW-U are:
  - The CC-POI.
  - The IRI-POI.

When EPC-5GC interworking architecture is used and the PGW-C and PGW-U are part of combined SMF+PGW-C and UPF+PGW-U respectively:

- The LI functions present in the SMF+PGW-C are:
  - The IRI-POI.
  - The CC-TF.
  - The IRI-TF.
- The LI functions present in the UPF+PGW-U are:

- The CC-POI.
- The IRI-POI.

6.3.3.1.2 Non-CUPS architecture

Figure 6.3-2 shows the LI architecture for non-CUPS SGW/PGW based interception.

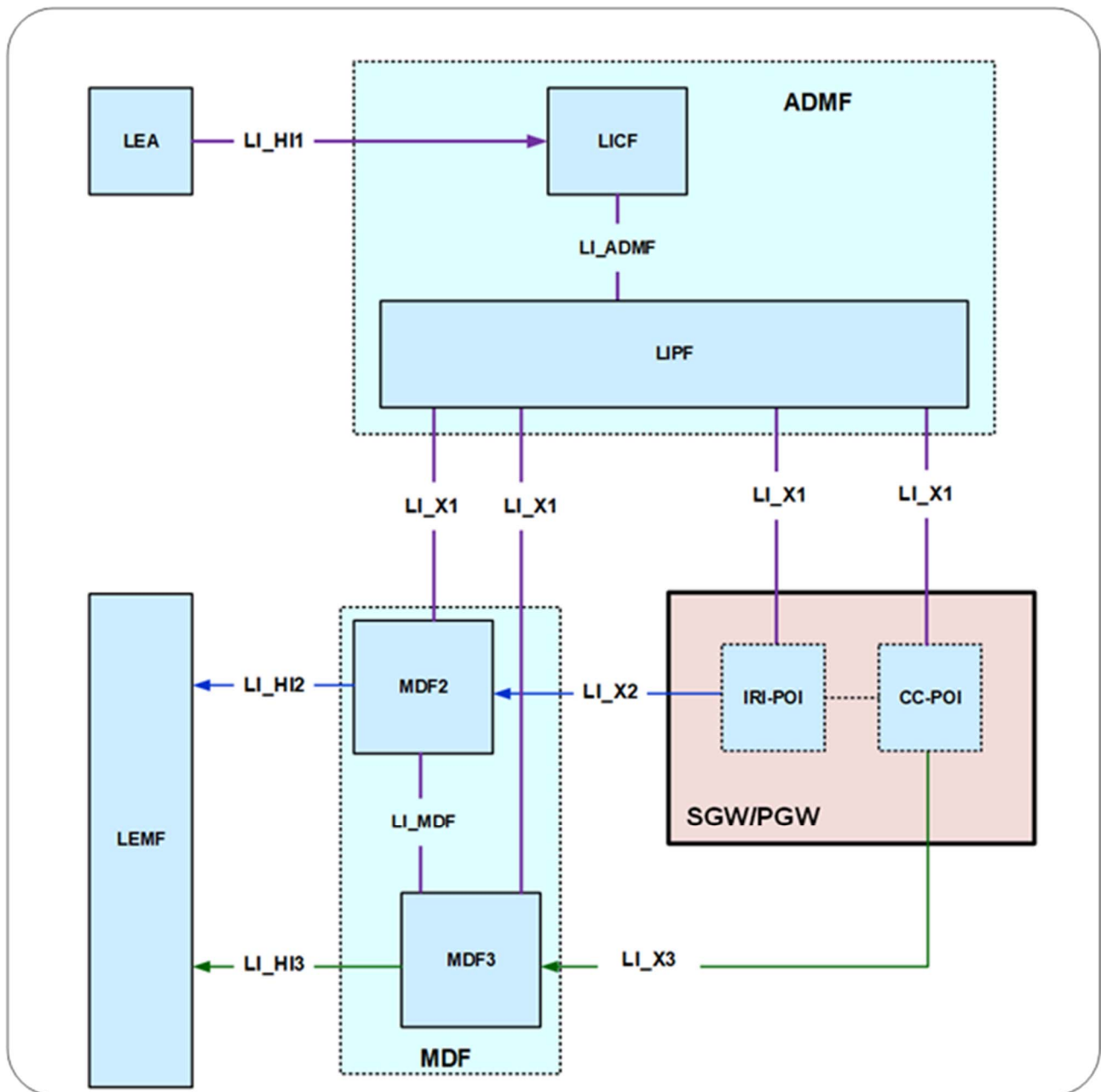

Figure 6.3-2: LI architecture for LI at non-CUPS SGW/PGW

The LICF present in the ADMF receives the warrant from an LEA, derives the intercept information from the warrant and provides the same to the LIPF.

The LIPF present in the ADMF provisions IRI-POI present in the SGW/PGW, MDF2 and MDF3 over the LI\_X1 interfaces. To enable the interception of the target's user plane packets (e.g. when the warrant requires the interception of communication contents), the CC-POI present in the SGW/PGW is also provisioned with the intercept data.

NOTE: The IRI-POI and CC-POI represented in figure 6.3-2 are logical functions and require correlation information be shared between them; they may be handled by the same process within the SGW/PGW.

The IRI-POI present in the SGW/PGW detects the target UE's bearer activation, modification and deactivation, generates and delivers the xIRI to the MDF2 over LI\_X2. The MDF2 delivers the IRI messages to the LEMF over LI\_HI2.

The CC-POI present in the SGW/PGW generates the xCC from the user plane packets and delivers the xCC (that includes the correlation number and the target identity) to the MDF3. The MDF3 delivers the CC to the LEMF over LI\_HI3.

A warrant that does not require the interception of communication contents, may require IRI messages that have to be derived from the user plane packets. To support the generation of related xIRI (i.e. that requires access to the user plane packets), the present document supports two implementation approaches described in clause 7.12.2

### 6.3.3.1.3 EPS CUPS Architecture

Figure 6.3-3 shows the LI architecture for EPS CUPS SGW/PGW based interception.

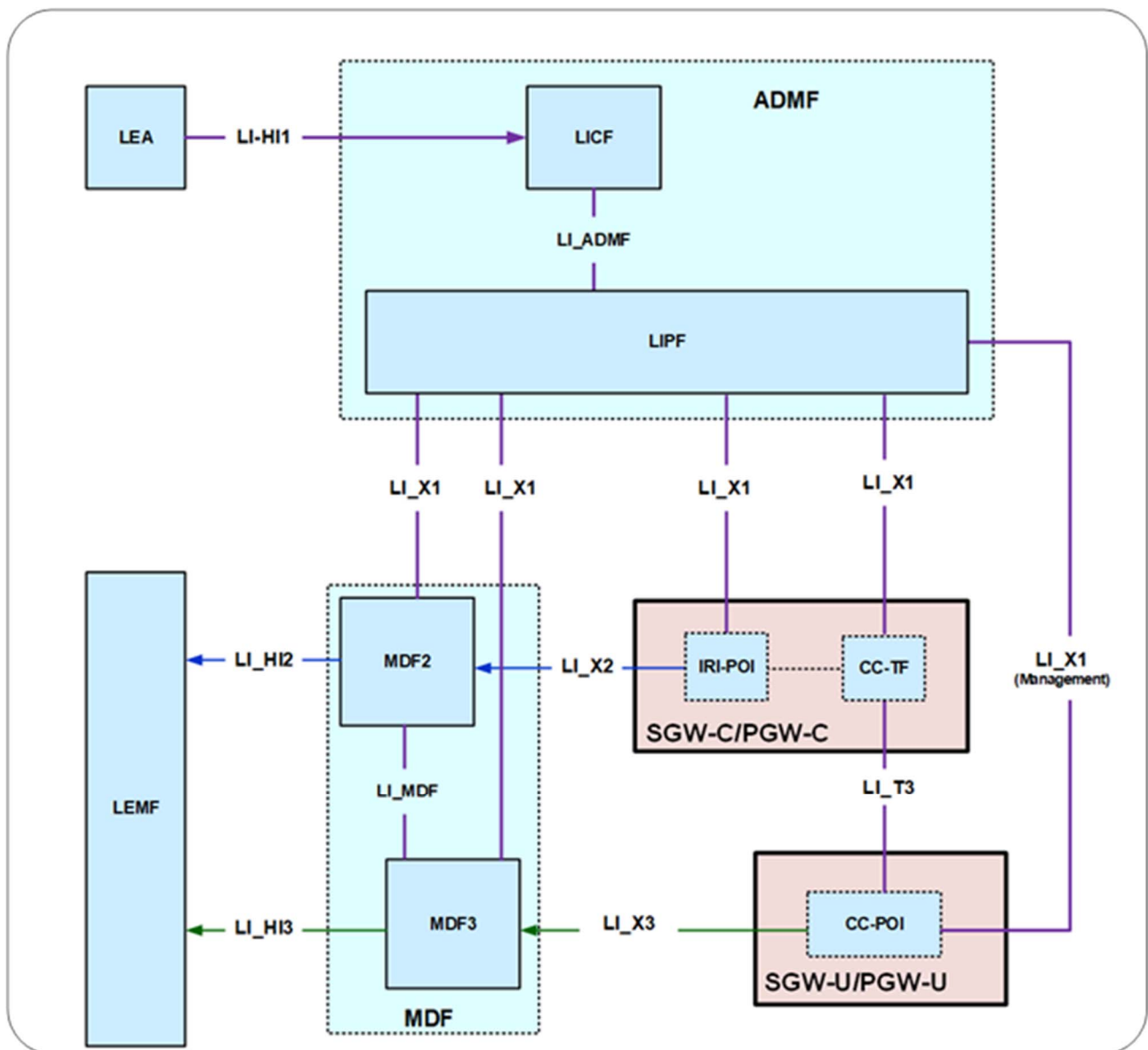

Figure 6.3-3: LI architecture for LI at EPS CUPS SGW/PGW

The LICF present in the ADMF receives the warrant from an LEA, derives the intercept information from the warrant and provides the same to the LIPF.

The LIPF present in the ADMF provisions IRI-POI present in the SGW-C/PGW-C and the MDF2 over the LI\_X1 interfaces. To enable the interception of the target's user plane packets (e.g. when the warrant requires the interception of communication contents), the CC-TF present in the SGW-C/PGW-C is also provisioned with the intercept data.

NOTE: The IRI-POI and CC-TF represented in figure 6.3-3 are logical functions and require correlation information be shared between them; they may be handled by the same process within the SGW-C/PGW-C.

When PGW-C and PGW-U (represented in figure 6.3-3) are part of combined SMF+PGW-C and UPF+PGW-U respectively in the EPC-5GC interworking architectures as shown in clause A.2.2, figure A.2-1 of the present document, the SMF+PGW-C and UPF+PGW-U shall exhibit the LI functions as described in clause 6.3.3.3.1.

The IRI-POI present in the SGW-C/PGW-C detects the target UE's bearer activation, modification and deactivation and generates and delivers the xIRI to the MDF2 over LI\_X2. The MDF2 delivers the IRI messages to the LEMF over LI\_HI2.

The CC-TF present in the SGW-C/PGW-C detects the target UE's bearer activation, modification and deactivation and provisions the CC-POI in the SGW-U/PGW-U.

The CC-POI present in the SGW-U/PGW-U generates the xCC from the user plane packets and delivers the xCC (that includes the correlation number and the target identity) to the MDF3. The MDF3 delivers the CC to the LEMF over LI\_HI3.

A warrant that does not require the interception of communication contents, may require IRI messages that have to be derived from the user plane packets. To support the generation of related xIRI (i.e. that requires access to the user plane packets), the present document supports two implementation approaches described in clause 7.12.2.

### 6.3.3.2 Target identities

The LI functions in the SGW/PGW shall support the following target identities for provisioning:

- IMSI.
- MSISDN.
- IMEI.

Interception performed on the above three identities are mutually independent, even though, an xIRI may contain the information about the other identities when available.

In the case of EPC-5GC interworking via combined SMF+PGW-C and UPF+PGW-U, the LI functions in the SMF+PGW-C shall support the following target identities:

- SUPI.
- IMSI.
- GPSI.
- MSISDN.
- PEI.
- IMEI.

Interception performed on the above identities may be mutually independent. Details for how the above identities are related are specified in TS 33.128 [15]. An xIRI may contain information about the other identities when available.



### 6.3.3.3 IRI events

#### 6.3.3.3.1 Option A

##### 6.3.3.3.1.1 General

When Option A described in clause 6.3.1 is used, xIRI provided by the IRI-POI in the SMF+PGW-C based on the events specified in TS 33.107 [11] shall not be generated; the IRI-POI in the SMF+PGW-C shall generate xIRI when it detects the following specific events or information specified in TS 33.128 [15]:

- PDN connection establishment.
- PDN connection modification.
- PDN connection release.
- Start of interception with an established PDN connection.
- Unsuccessful procedure.

When EPC/5GC interworking architecture is used, the xIRI for the events listed above are described in clause 6.3.3.3.1.2.

##### 6.3.3.3.1.2 xIRI records for architectures with EPC/5GC interworking

For the interception of home routed roaming sessions in the visited network, the POIs and TFs shall be present in the SGW and the SMF in the VPLMN and the xIRI records described in the present clause and clause 6.2.3.3 shall be generated.

For all other cases, the POIs and TFs shall be present in the SMF+PGW-C and SMF+PGW-U as described in clause 6.3.3.6.2 and the following events shall be generated.

The PDU session establishment xIRI is generated when the IRI-POI present in the SMF+PGW-C detects that a PDU session with mapped EBIs has been established for the target UE or that a PDN connection has been established for the target UE.

The PDU session modification xIRI is generated when the IRI-POI present in the SMF+PGW-C detects that a PDU session or EBIs are modified for the target UE or when a target UE's PDN connection from EPC is migrated to the 5GS or when a dedicated EPS bearer is activated or deactivated for the target UE.

The PDU session release xIRI is generated when the IRI-POI present in the SMF+PGW-C detects that a PDU session is released or when the default EBI for a PDN connection is deactivated for the target UE.

The start of interception with an established PDU Session xIRI is generated when the IRI-POI present in a SMF+PGW-C detects that interception is activated on the target UE that has an already established PDU session in the 5GS that has a mapped to PDN connection or an already established PDN connection in EPS. When a target UE has multiple 5GC PDU sessions mapped to multiple PDN connections in EPC or when a target UE has multiple PDN connections in EPC, this xIRI shall be sent for each PDU session and each PDN connection with different correlation information values.

When xIRIs are generated due to the detection of a PDU session with mapped EBIs, no separate xIRIs shall be generated for the same events for the corresponding PDN connection.

When additional warrants are activated on a target UE, MDF2 shall be able to generate and deliver the start of interception with an established PDU session related IRI messages to the LEMF associated with the warrants without receiving the corresponding start of interception with an established PDU session xIRI.

When the warrant requires the packet header information reporting, the following xIRI shall be generated:

- Packet header information report (see clause 7.12.2).

The generation of packet header information reporting can be done by either the IRI-POI present in the UPF+PGW-U or the MDF2.

#### 6.3.3.3.2 Option B

The IRI-POI present in the SGW/PGW shall generate xIRI, when it detects the applicable events specified in TS 33.107 [11].

#### 6.3.3.4 Common IRI parameters

The list of xIRI parameters are specified in TS 33.128 [15]. All xIRI shall include the following:

- Target identity.
- Time stamp.
- Correlation information.
- Location information.
- Session related information.

#### 6.3.3.5 Specific IRI parameters

The parameters in each xIRI are defined in TS 33.128 [15].

#### 6.3.3.6 Network topologies

##### 6.3.3.6.1 Network topologies without EPC/5GC interworking

The SGW shall provide the IRI-POI and CC-POI functions (and the IRI-TF and CC-TF in CUPS architecture) in the following network topology cases:

- Based on the deployment option, in a non-roaming case for E-UTRAN.
- Home Routed Roaming case, in VPLMN.
- Based on the deployment option, Local Breakout Roaming case in VPLMN.

The PGW shall provide the IRI-POI and CC-POI functions (and the IRI-TF and CC-TF in CUPS architecture) in the following network topology cases:

- Based on the deployment option, in a non-roaming case for E-UTRAN.
- Home Routed Roaming case, in HPLMN.
- Non-3GPP access case, in the HPLMN.
- Based on the deployment option, Local Breakout Roaming case in VPLMN.

For the case of access to EPC via E-UTRAN, in case of non-roaming, at least one between SGW and PGW shall provide the IRI-POI and CC-POI (and the IRI-TF and CC-TF in CUPS architecture).

For the case of access to EPC via E-UTRAN, in case of Local Breakout Roaming, at least one between SGW and PGW shall provide the IRI-POI and CC-POI (and the IRI-TF and CC-TF in CUPS architecture).

When the target UE has multiple bearers active, the generation and delivery of xCC for each bearer shall be done independently, each with separate correlation information.

##### 6.3.3.6.2 Network topologies with EPC/5GC interworking

The SMF+PGW-C shall provide the IRI-POI, the IRI-TF and the CC-TF and the UPF+PGW-U shall provide the IRI-POI and CC-POI in the following network topology cases:

- In the non-roaming case.
- Roaming with local breakout case, in VPLMN.

- Home Routed Roaming case, in HPLMN.
- Non-3GPP access case, in the HPLMN.
- Local Breakout Roaming with Non-3GPP access case, in the VPLMN.

The SGW shall provide the IRI-POI and CC-POI functions (and the IRI-TF and CC-TF in CUPS architecture) in the following network topology cases:

- Home Routed Roaming case, in the VPLMN.

When the target UE has multiple bearers active, the generation and delivery of xCC for each bearer shall be done independently, each with separate correlation information.

### 6.3.3.7 EPC-5GC Interworking via SMF+PGW-C and UPF+PGW-U

In the case of interworking between EPC and 5GC via combined nodes (e.g. SMF+PGW-C, UPF+PGW-U) as defined in TS 23.501 [2] clause 5.17, all of the requirements found in clause 6.2.3 (LI for SMF/UPF) and clause 6.3.3 (LI at the SGW/PGW) of the present document apply with the following modifications:

- PDN Connection context information present in the combined SMF+PGW-C shall be reported via the mechanisms defined in TS 33.128 [15] clause 6.2.3.
- User identifiers that are EPC specific but known in the combined SMF+PGW-C are reported as supplemental user IDs per TS 33.128 [15] clause 6.2.3.

## 6.3.4 LI at ePDG

### 6.3.4.1 Architecture

In the EPC network, the ePDG is the gateway which allows interworking between non-3GPP access and 3GPP network. The ePDG functionalities are specified in TS 23.402 [23].

NOTE 1: The present document supports LI for non-3GPP accesses connected to EPC using GTP-based S2a or GTP-based S2b as specified in TS 23.402 [23]. Other scenarios are covered by TS 33.107 [11].

The ePDG shall include an IRI-POI that has the LI capabilities to generate the target UE's bearer related xIRI.

In addition, the ePDG shall include a CC-POI that has the LI capabilities to duplicate the user plane packets from the EPS bearers related to a target UE.

Figure 6.3-4 shows the LI architecture for ePDG based interception.

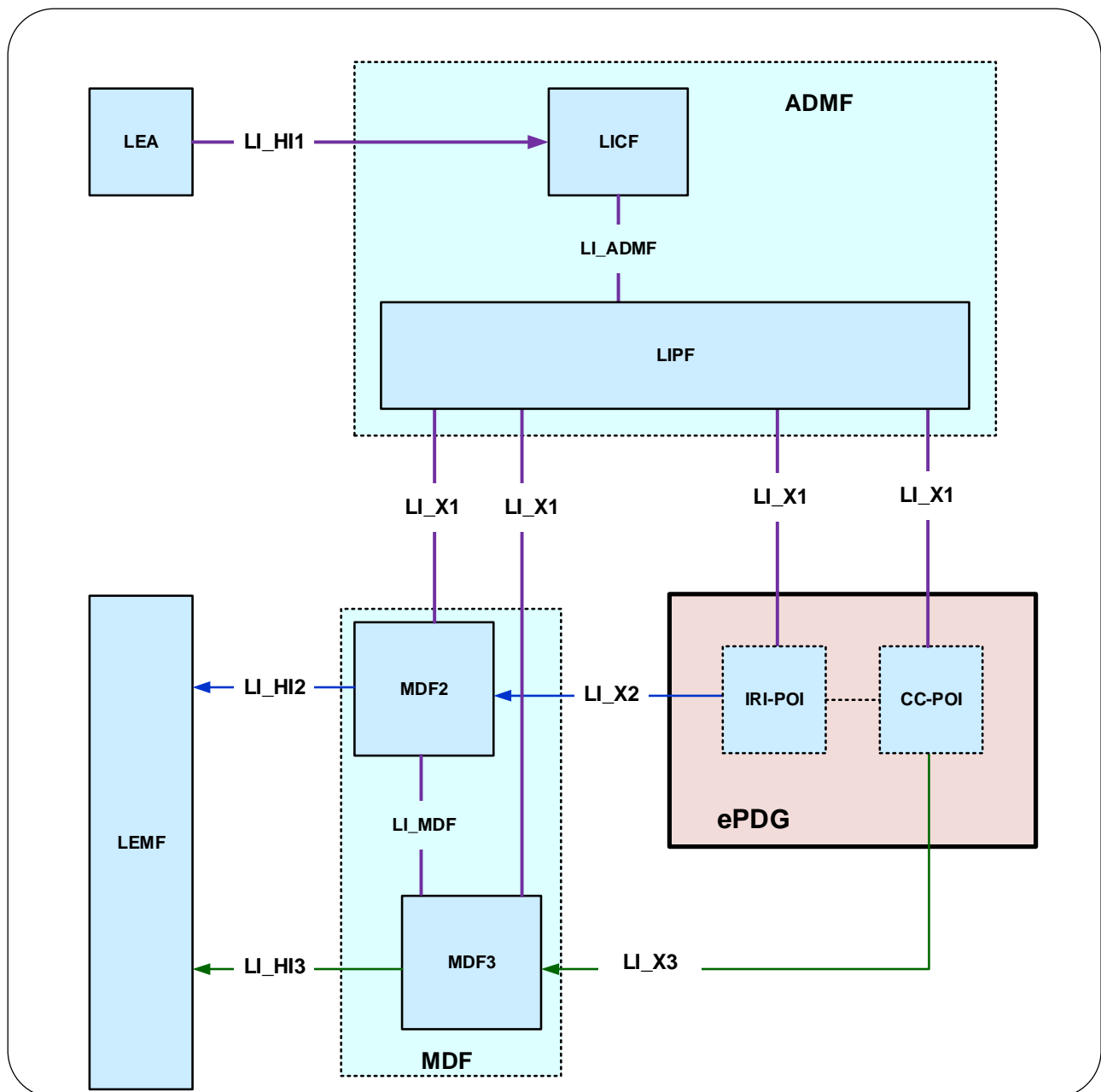

**Figure 6.3-4: LI architecture for LI at ePDG**

The LICF present in the ADMF receives the warrant from an LEA, derives the intercept information from the warrant and provides the same to the LIPF.

The LIPF present in the ADMF provisions IRI-POI present in the ePDG, MDF2 and MDF3 over the LI\_X1 interfaces. To enable the interception of the target's user plane packets (e.g. when the warrant requires the interception of communication contents), the CC-POI present in the ePDG is also provisioned with the intercept data.

NOTE 2: The IRI-POI and CC-POI represented in figure 6.3-3 are logical functions and require correlation information be shared between them; they may be handled by the same process within the ePDG.

The IRI-POI present in the ePDG detects the target UE's bearer activation, modification and deactivation, generates and delivers the xIRI to the MDF2 over LI\_X2. The MDF2 delivers the IRI messages to the LEMF over LI\_HI2.

The CC-POI present in the ePDG generates the xCC from the user plane packets and delivers the xCC (that includes the correlation number and the target identity) to the MDF3. The MDF3 delivers the CC to the LEMF over LI\_HI3.

#### 6.3.4.2 Target identities

The target identities which the LIPF present in the ADMF provisions to the IRI-POI and CC-POI present in the ePDG are specified in TS 33.107 [11].

#### 6.3.4.3 IRI events

The IRI-POI present in the ePDG shall generate xIRI, when it detects the applicable events specified in TS 33.107 [11].

#### 6.3.4.4 Common IRI parameters

The list of xIRI parameters are specified in TS 33.128 [15]. Each xIRI shall include at the minimum the following information:

- Target identity.
- Time stamp.
- Correlation information.
- Location information.
- Bearer related information.

#### 6.3.4.5 Specific IRI parameters

The parameters in each xIRI are defined in TS 33.128 [15].

#### 6.3.4.6 Network topologies

The ePDG shall provide the IRI-POI and CC-POI functions in the following network topology cases:

- Roaming case, in VPLMN.

### 6.4 3G

The present document does not specify LI functionality for 3G / UMTS. LI capabilities for 3G / UMTS for this release are specified in TS 33.107 [11].

### 6.5 VoNR

Voice over NR as defined in TS 23.501 [2] and TS 23.502 [4] is intended to provide equivalent functionality to VoLTE in 4G.

LI requirements for VoNR based on IMS are defined in clause 7.4 of the present document.

## 6.6 4G/5G Interworking

Figure 6.6-1 depicts interworking between EPC and the 5G architecture. The network functions are depicted in grey, while the LI elements are depicted in blue.

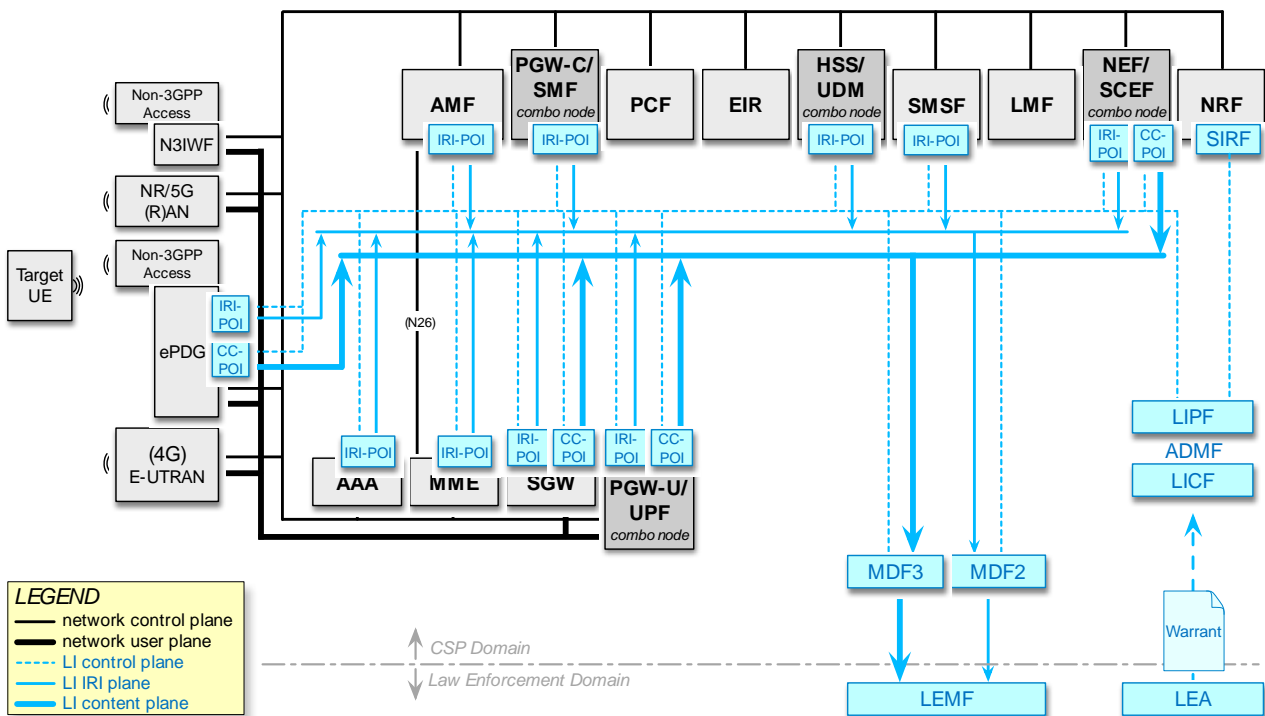

**Figure 6.6-1: EPC/5G Interworking LI architecture**

NOTE: A CC-POI may also be present in the MME and SMF for roaming NIDD interception, which are not shown in figure 6.6-1.

## 7 Service layer based interception

### 7.1 General

Clause 7 provides details for the configuration of the high-level LI architecture for service layer based interception and for network function which are not specific to a single access type or network service (e.g. subscription management functions). It defines aspects of the LI configuration specific to each service under consideration, while aspects concerning network over which the service is delivered (e.g. 5G) are considered in clause 6.

### 7.2 Central subscriber management

#### 7.2.1 General

Clause 7.2 provides LI architecture and requirements for the CSP 3GPP subscriber database LI reporting. Central subscriber databases are common for all CSP network services, including both the network layer and the service layer. This clause 7.2 provides requirements for both user session related interception events and requirements for reporting of changes to the subscriber information held within the 3GPP subscriber databases, which may or may not be directly related to service usage.

## 7.2.2 LI at UDM

### 7.2.2.1 Architecture

The UDM provides the unified data management for UE. The UDM shall have LI capabilities to generate the target UE's serving system (e.g. VPLMN Id or AMF Id related xIRI). Extending the generic LI architecture presented in clause 5, figure 7.2-1 below gives a reference point representation the LI architecture with UDM as a CP NF providing the IRI-POI functions.

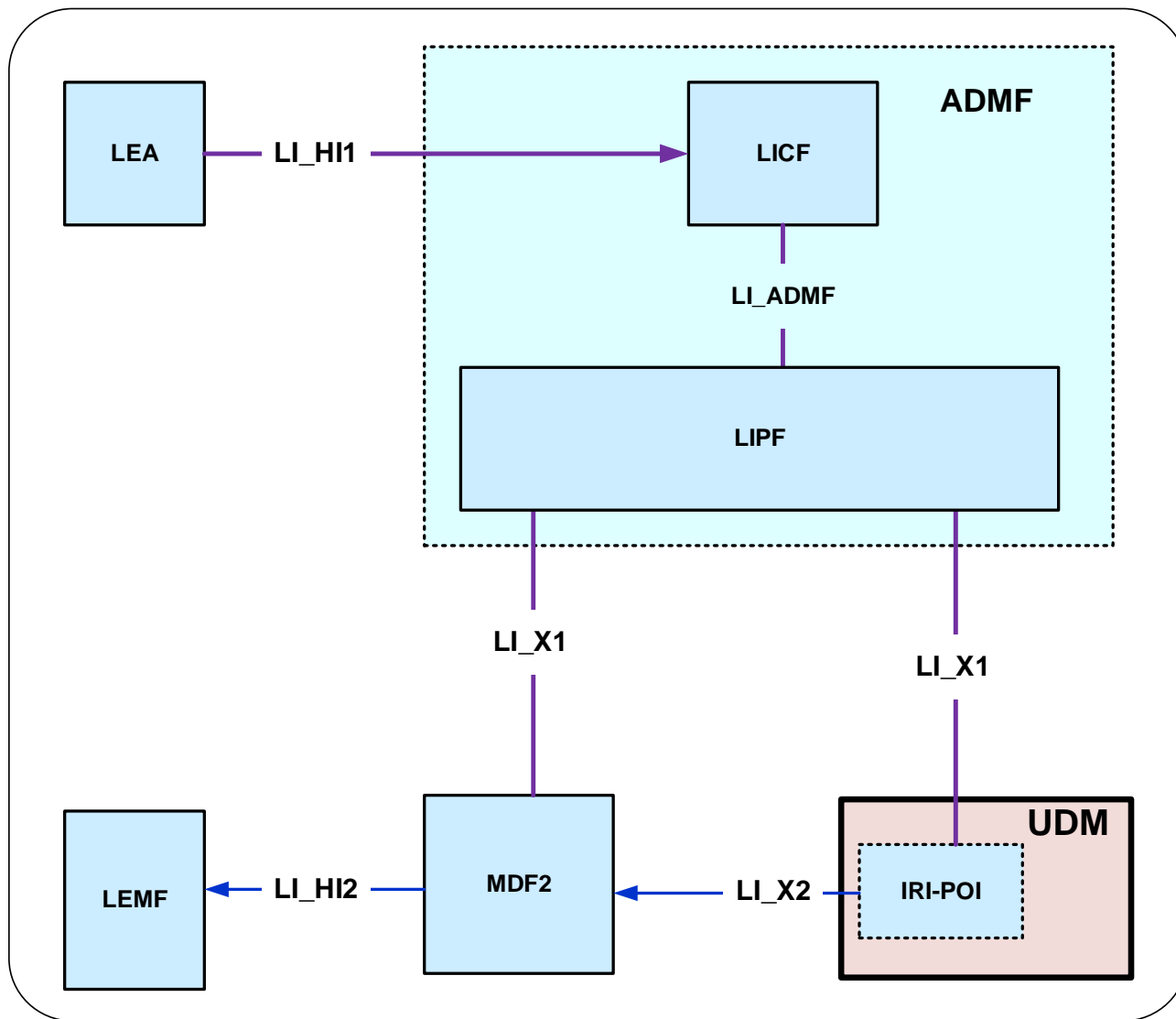

Figure 7.2-1: LI architecture for LI at UDM

The LICF present in the ADMF receives the warrant from an LEA, derives the intercept information from the warrant and provides it to the LIPF.

The LIPF present in the ADMF provisions IRI-POI (over LI\_X1) present in the UDM and MDF2. The LIPF may interact with the SIRF (over LI\_SI) present in the NRF to discover the UDM in the network.

The IRI-POI present in the UDM detects the target UE's service area registration and subscription related functions, generates and delivers the xIRI to the MDF2 over LI\_X2. The MDF2 generates and delivers the IRI messages based on received xIRI to the LEMF over LI\_H2.

### 7.2.2.2 Target identities

The LIPF present in the ADMF provisions the intercept information associated with the following target identities to the IRI-POI present in the UDM:

- SUPI.
- PEI.
- GPSI.
- IMPU/IMPI.

The interception performed on the above identities are mutually independent, even though, an xIRI may contain the information about the other identities when available.

### 7.2.2.3 Identity privacy

TS 33.501 [9] defines the ability to prevent the SUPI being exposed over the 5G RAN through the use of SUCI. Where SUPI privacy is implemented by both the UDM and UE, the SUPI is not sent in the clear over the RAN. Therefore, the UDM shall ensure that the SUPI is provided to the serving AMF in both initial registration and re-registration procedures as defined in TS 33.501 [9].

### 7.2.2.4 IRI events

The IRI-POI present in the UDM shall generate xIRI, when the UDM detects the following specific events or information:

- Serving system.
- Subscriber record change.
- Cancel location.
- Location information request.
- Location information result.
- UE information response.
- UE authentication response.

A serving system xIRI is generated when the IRI-POI present in the UDM detects the target UE registration or re-registration related notifications. The AMF Id or the MME Id, or the VPLMN Id (when the other two are not known) is used as the serving system identifier in a serving system xIRI.

**NOTE:** The serving system xIRI may carry the information of one or more serving systems based on the target UE's network connectivity.

A subscriber record change xIRI is generated when the IRI-POI present in the UDM detects that the associated GPSI, or SUPI, or PEI is changed. In addition, a subscriber record change xIRI is generated when the associated GPSI or, SUPI, or PEI is de-provisioned. A subscriber record change xIRI is also generated when the target UE's user service identifiers are modified (e.g. subscribed S-NSSAIs, subscribed CAG).

A cancel location xIRI is generated when the IRI-POI present in the UDM detects that a de-registration notification is sent, or received, by the UDM.

A location information request xIRI is generated when the IRI-POI present in the UDM detects that the UDM received a query for the location information of the target UE from a different PLMN (e.g. inbound SMS routing) with a known PLMN Id.

A location information result xIRI is generated when the IRI-POI in the UDM detects that the UDM received a LocationInfoRequest from an NF service consumer (i.e. HSS) and responds with a LocationInfoResult to the NF service consumer.



A UE information response xIRI is generated when the IRI-POI present in the UDM detects that the UDM received a ProvideUeInfo request and returns a UeInfo response.

A UE authentication response xIRI is generated when the IRI-POI present in the UDM detects that the UDM received an authentication info request from the HSS or AUSF and an authentication info result is sent.

### 7.2.2.5 Common IRI parameters

The list of xIRI parameters are specified in TS 33.128 [15]. All xIRIs shall include the following information:

- Target identity.
- Time stamp.

### 7.2.2.6 Specific IRI parameters

The parameters in each xIRI are defined in TS 33.128 [15].

### 7.2.2.7 Network topologies

The UDM shall provide the IRI-POI functions in the following network topology cases:

- Non-roaming case.
- Roaming case, in HPLMN.

## 7.2.3 LI at HSS

### 7.2.3.1 Architecture

The [HSS](#) contains the subscription-related information for all users served by the CSP. The HSS provides the support functions in the mobility management, session setup, user authentication and access authorization.

The HSS shall have LI capabilities to generate the xIRIs as described in clause 7.2.3.3. The present document specifies two options for HSS LI capabilities:

1. Use TS 33.107 [11] and TS 33.108 [21] natively as defined in those documents.
2. Use the capabilities specified below in the present document for stage 2 and in TS 33.128 [15] for stage 3.

Extending the generic LI architecture presented in clause 5, figure 7.2-2 below gives a reference point representation the LI architecture with HSS as a CP NF providing the IRI-POI functions.

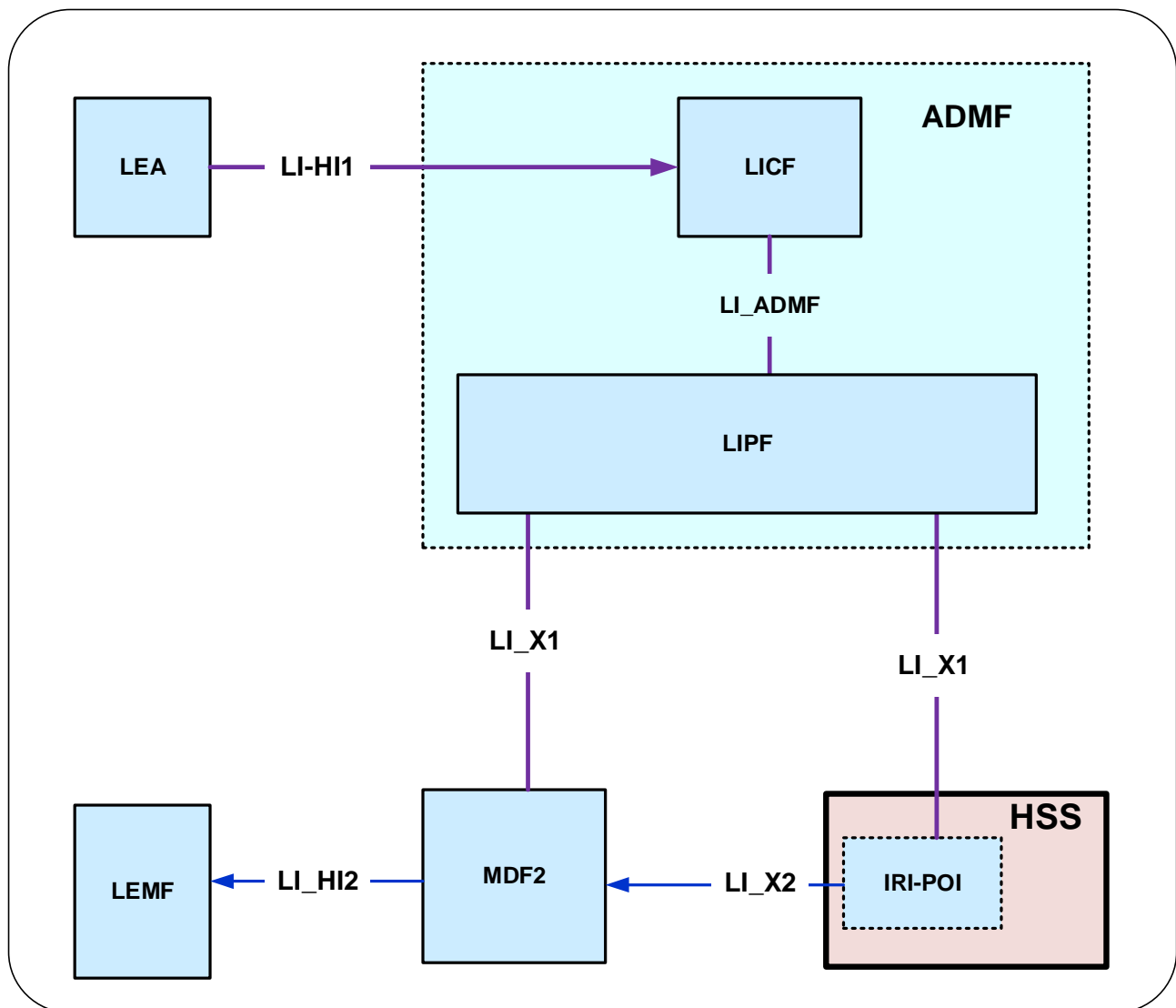

**Figure 7.2-2: LI architecture for LI at HSS**

The LICF present in the ADMF receives the warrant from an LEA, derives the intercept information from the warrant and provides it to the LIPF.

The LIPF present in the ADMF provisions IRI-POI (over LI\_X1) present in the HSS and MDF2.

The IRI-POI present in the HSS detects the target UE's service area registration and subscription related functions, generates and delivers the xIRI to the MDF2 over LI\_X2. The MDF2 generates and delivers the IRI messages based on received xIRI to the LEMF over LI\_H2.

The HSS shall provide the IRI-POI functions independent of the services on which the interception is active.

When multiple intercepts are active, IRI-POI functions in the HSS may send one xIRI which can then be distributed to the LEMFs associated with those multiple intercepts from the MDF2.

### 7.2.3.2 Target identities

The LIPF present in the ADMF provisions the intercept information associated with the following target identities to the IRI-POI present in the HSS:

- IMSI.
- IMEI.
- MSISDN.

- IMPU/IMPI.

The interception performed on the above identities are mutually independent, even though, an xIRI may contain the information about the other identities when available.

### 7.2.3.3 IRI events

The IRI-POI present in the HSS shall generate xIRI, when it detects the applicable events specified in TS 33.107 [11].

### 7.2.3.4 Common IRI parameters

The list of xIRI parameters are specified in TS 33.128 [15]. All xIRIs shall include the following information:

- Target identity.
- Time stamp.

### 7.2.3.5 Specific IRI parameters

The parameters in each xIRI are defined in TS 33.128 [15].

### 7.2.3.6 Network topologies

The HSS shall provide the IRI-POI functions in the following network topology cases:

- Non-roaming case.
- Roaming case, in HPLMN.

## 7.3 Location

### 7.3.1 General

This clause provides location reporting functionality for both UE location obtained as part of normal network access or user service usage and location actively triggered through location based services or other LALS reporting.

In addition, clause 7.3.4 describes Cell Supplemental Information (CSI) (e.g., civic address, geographical coordinates, or operator specific information) derived from CSP databases.

For all UE locations obtained, generated or reported to the MDF2, the POI shall report the time at which the location was established by the location source (e.g. AMF, MME or HSS/UDM) and provide this to the MDF along with the location information.

For all UE locations obtained, generated or reported to the ICF, the IEF shall report the time at which the location was established by the location source (e.g. AMF) and provide this to the ICF along with the location information.

### 7.3.2 Service usage location reporting

#### 7.3.2.1 General

This clause specifies requirements relating to location reporting that is obtained as part of target user usage of network services. Only location reporting that is available as part of the network service being used by the target user is specified in this clause.

#### 7.3.2.2 Embedded location reporting

This clause defines requirements for reporting of location when location is provided as part of other associated interception information sent from the POI to the MDF2.

Location shall be available at the start and end of a user communication. In addition, where available, a POI shall be able to provide location updates to the MDF2 (e.g. due to UE mobility at the AMF or MME).

The following information shall be transferred from the POI to the MDF2 as part of POI events for which location reporting is required:

- Target location(s).
- Date/time of UE location(s) (if target location provided).
- Source location information (if target location provided).

### 7.3.2.3 Separated location reporting

This clause defines a dedicated location reporting event when location cannot be reported (or is not available) at the same time as the POI output event for which the location was required is sent to the MDF2. The event shall also be used when an updated location becomes available and no other suitable POI output event message is triggered (e.g. mid-session location update).

Location reporting availability shall be the same as for embedded location reporting in clause 7.3.2.2.

The following information needs to be transferred from the POI to the MDF2 in order to enable a MDF2 to perform its functionality:

- Target identity.
- Event date/time.
- Target location(s).
- Date/time of UE location(s).
- Nature and identity of the POI.
- Location source(s).

## 7.3.3 Lawful Access Location Services (LALS)

### 7.3.3.1 General

LALS provides lawful access to the target's location. LALS is based on the Location Services (LCS) capabilities defined in TS 23.271 [5], TS 23.273 [30] and inOMA MLP [6]. The 5G Core Network support of LCS is described in TS 23.501 [2] clause 4.4.4 and TS 23.502 [4] clause 4.13.5.

LALS shall adhere to the requirements in TS 33.126 [3] clauses 6.6 (Security) and 6.3 (Detect and Capture). The LCS supporting LALS shall be able to provide priority to LALS requests. The subscriber location privacy settings shall be overridden for LALS by setting the privacy override indicator to "override" in the LI LCS client profile in the GMLC (see TS 23.273 [30] clause 5.4.4).

For inbound roaming targets, the VPLMN LCS functional entities fulfilling LALS requests, by default, shall not communicate with the target's HPLMN, as it may cause detectability issues, but rather the GMLC shall be able to determine the serving AMF/MME from which it can acquire the inbound roaming target's location. Detectability issues may also exist when LALS is invoked for outbound roaming targets. This means by default, the GMLC shall refrain from performing the positioning of an outbound roaming target.

NOTE 0: The visited GMLC may send the location request to all the AMF/MME of the VPLMN. If the visited GMLC has knowledge of the last AMF/MME serving the target UE, it may use that one in the first attempt.

Depending on national requirements and LCS capabilities of the CSP, the location information provided by LALS may vary in location information types (mobile network cell ID, location shape and geo-coordinates, civic address, or a combination of those), in the set of additional location parameters (map data, motion state, speed, etc.), as well as in the accuracy of provided location information.

NOTE 1: The accuracy of positioning is, usually, a trade-off for the location acquisition delay. It also depends on other positioning technology specific factors.

The parameters controlling the LALS output are either delivered per warrant over the LI\_X1 interface from the ADMF to the LI-LCS Client, or to the Location Triggering Function (LTF, see clause 7.3.3.3), or are pre-configured in the LI-LCS Client. The LI-LCS Client is a special type of IRI-POI in the CSP network fulfilling the role of the LCS client for LALS purposes. As such, the LI-LCS client shall support all the requirements and interfaces in accordance with 3GPP TS 23.273 [30] for an LCS client.

NOTE 2: The LI-LCS Client profile at GMLC is to be provisioned and accessed by authorized personnel only. The mechanism of this functionality is outside the scope of the present document.

There are two types of the location interception defined in the present document: target positioning and triggered location.

Target positioning determines the target's location independently of the services used by the target.

Triggered location determines the LALS based location of the target when specific network or service events related to the target occur.

The warrant for target positioning and for triggered location of the same target may be independent of each other and may be overlapping in time or combined in a single intercept warrant by the LEA.

There may be multiple active LALS warrants from different LEAs at any given time.

### 7.3.3.2 Target positioning

#### 7.3.3.2.1 General

As required by TS 33.126 [3] R6.3 – 370, the location provision variants supported in the current document are immediate location and periodic location.

The LI-LCS client shall include an IRI-POI that has the LI capabilities to generate the target UE's location related xIRI.

Figure 7.3-1 shows the architecture for LALS where the LI-LCS client provides the target's location and associated information towards the MDF2 over the LI\_X2 interface as per the ADMF request for target positioning delivered over LI\_X1 interface.

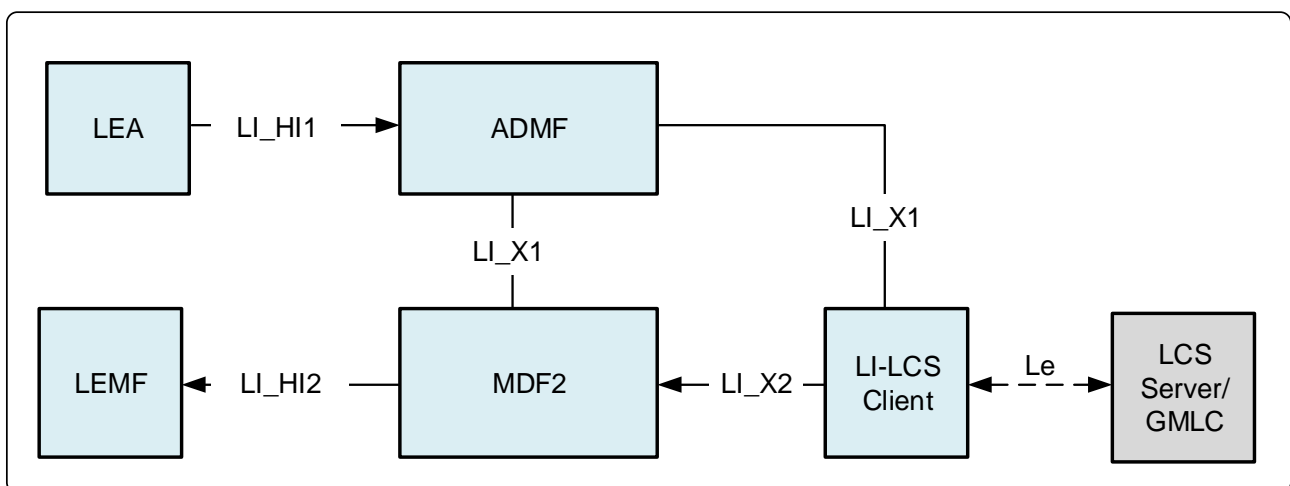

Figure 7.3-1: LALS model for target positioning

NOTE: The Le interface is specified in OMA MLP [6].

#### 7.3.3.2.2 Immediate location provision

The request for immediate location provision is delivered to the LI-LCS client over the LI\_X1 interface. Upon receiving the request, the LI-LCS client initiates a Location Immediate Request (LIR, see TS 23.271 [5]) to the LCS

Server/GMLC supporting LALS over the Le interface and reports the acquired location to the MDF2 over LI\_X2.

While waiting for a response to an LIR from the LCS Server/GMLC, the LI-LCS client may receive and process additional LIRs from the ADMF over the LI\_X1.

NOTE: The LCS Server/GMLC supporting LALS can be optimized to provide the same single location estimation in response to multiple positioning requests arriving in temporal proximity of each other.

The resulting immediate location information shall be delivered by the LI-LCS client as xIRI over LI\_X2 to the MDF2. The MDF2 generates and delivers the IRI messages based on received xIRI to the LEMF over LI\_H2.

### 7.3.3.2.3 Periodic location provision

The request for periodic location provision is delivered to the LI-LCS client over the LI\_X1 interface.

The request for periodic location from the ADMF to the LI-LCS client may include a set of parameters defining the duration of reporting, report periodicity, etc. The description of the service response parameters is provided in clause 7.3.3.4. The periodic location result shall be delivered by the LI-LCS client as xIRI over LI\_X2 to the MDF2. The MDF2 generates and delivers the IRI messages based on received xIRI to the LEMF over LI\_H2.

The periodicity of the LALS reports shall be controlled by the LI-LCS client. The LI-LCS client shall issue a series of Location Immediate Requests (LIR, see TS 23.271 [5]) at required time intervals.

### 7.3.3.3 Triggered location

The Triggered location is the capability of providing LALS based location information when specific network or service events related to the target occur. While IRI generated by the event that also triggers the LALS may have the location information included (in the form of cell ID), LALS may provide additional location parameters, such as the target geo-location, velocity, etc. (see TS 33.126 [3] R6.3 – 270). The triggered location reporting utilizes the immediate location variant.

The LALS triggered location architecture in figures 7.3-2 and 7.3-3 depicts the Location Triggering Function (LTF). The LTF is an IRI-TF and resides in the same NF (e.g. AMF) that has the IRI-POI or in an MDF2. The LTF is responsible for triggering the IRI-POI in the LI-LCS Client when a specific event related to the target is observed at the co-located IRI-POI or received at the MDF2 in which the LTF is residing.

Figure 7.3-2 depicts the architecture of Triggered Location for IRI acquisition and delivery for the case when the LTF is residing in the same NF that has the IRI-POI reporting IRI events for the target.

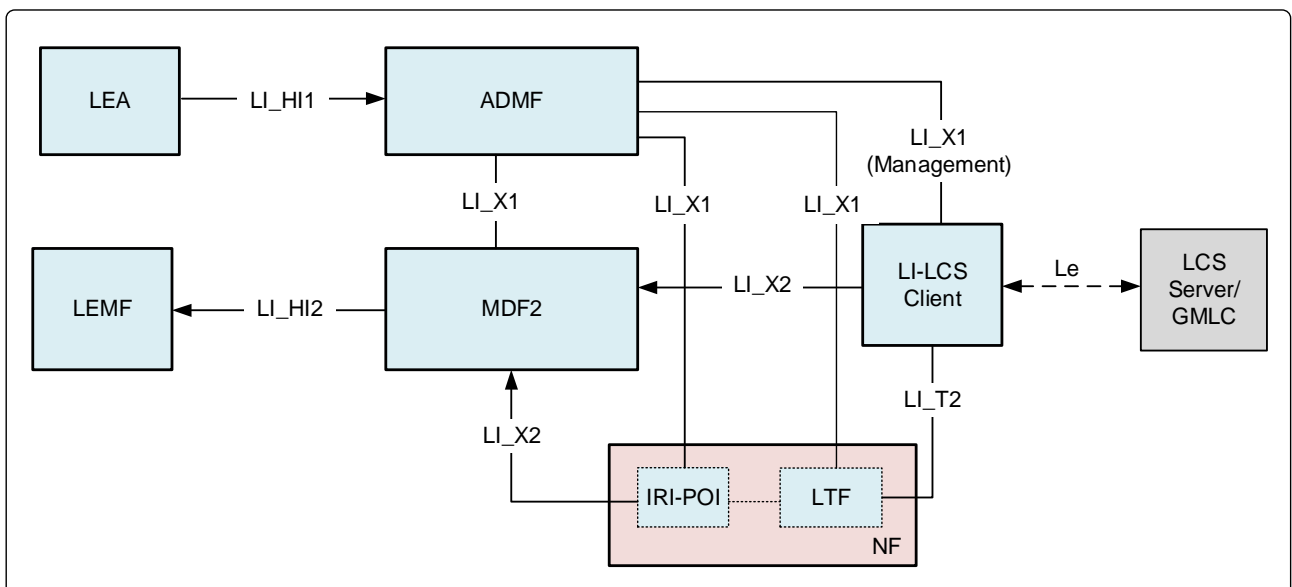
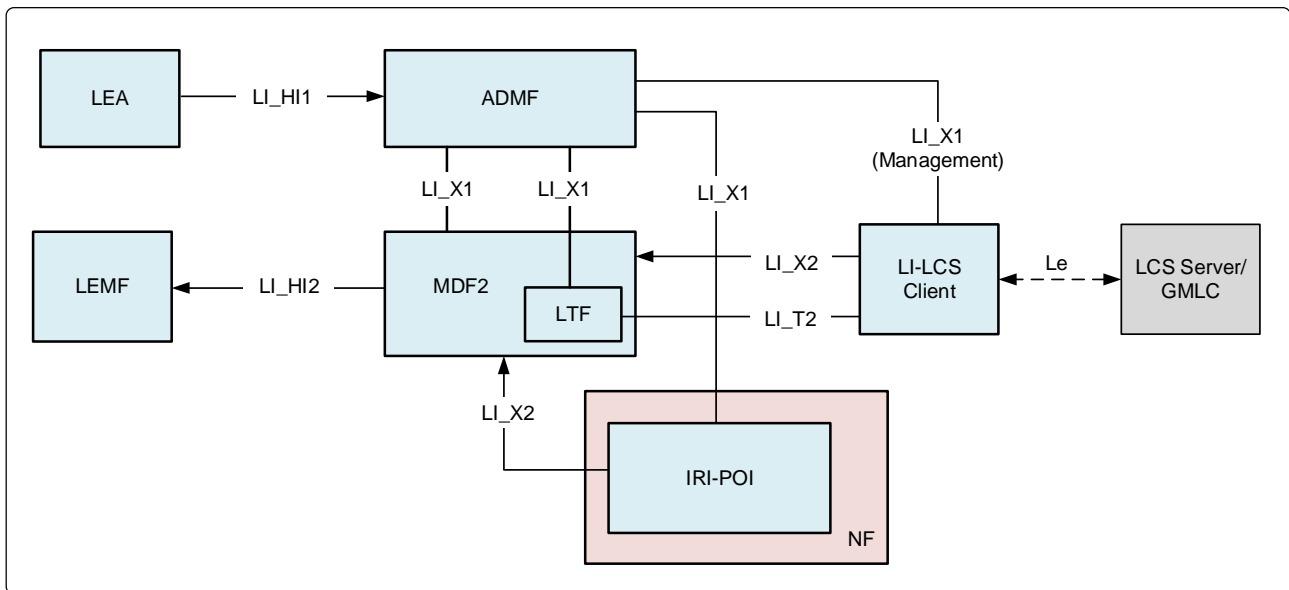

Figure 7.3-2: LALS model for triggered location (POI/LTF option)

NOTE 1: The IRI-POI and LTF represented in figure 7.3-2 are logical functions and require correlation information be shared between them; they may be handled by the same process within the NF.

Figure 7.3-3 depicts the architecture of triggered location acquisition and delivery for the case when the LTF is embedded into an MDF2.



**Figure 7.3-3: LALS Model for triggered location (MDF/LTF option)**

In case of triggered location, the LTF (present in either an NF hosting an IRI-POI or in a MDF2) is provisioned by the ADMF over LI\_X1 interface.

As part of this request, the ADMF provides the address for the LTF to reach the LI-LCS client for use on the LI\_T2 interface. The IRI-POI (s) or the MDF2 then arm the LTF(s).

The LTF triggers the LI-LCS client over the LI\_T2 interface.

The LALS result is delivered to MDF2 from the LI-LCS Client as xIRI over the LI\_X2 interface asynchronously with the associated IRI events delivered by the IRI-POI. To enable correlation between the LALS reports and the associated IRI events, the LTF shall include the correlation information of the IRI event, if provided by the IRI-POI, into the LI\_T2 trigger.

NOTE 2: The IRI events may contain the location information obtained by other means, e.g. NPLI. The LALS reports are augmenting that information with extra details and accuracy.

#### 7.3.3.4 LI\_X2 interface for target positioning and triggered location

The following information needs to be delivered from the LI-LCS Client to MDF2 in order to enable the MDF2 to format and deliver LALS intercept product to LEMF:

- Target identity.
- Target reported location(s).
- Date/time(s) location(s) established by reporting function.
- Additional location parameters based on operator policy.
- Correlation information.

### 7.3.4 Cell database information reporting

When a cell identity is provided for the target's location in an IRI message, the CSP may also provide CSI for the reported cell identity. The MDF2 may retrieve CSI by access to a CSP maintained database (referred to as CSP Cell Database) as shown in figure 7.3.4-1. The CSP delivers the CSI either via the IRI message generated from the corresponding xIRI, or asynchronously in a stand-alone Cell Site Report (CSR) IRI message.

The following information shall be delivered when CSI is provided in IRI message or a MDF2 generated CSR:

- LIID.
- Cell identity.
- Date/time(s) established by MDF2.
- Cell supplemental information.

Cell supplemental information (CSI) shall include the physical location (e.g. geographical coordinates) information for the reported cell. If the reported cell is not fixed to a permanent location, the report should indicate the cell mobility type (e.g. nomadic cell, vehicle-mounted cell) as well as the time period of the location validity.

If CSI for a cell identity has been previously reported to the LEMF for the current interception, CSI may be omitted, if allowed by the warrant.

If the CSP does not support CSR or CSI, the database can be provided by non-real-time means.

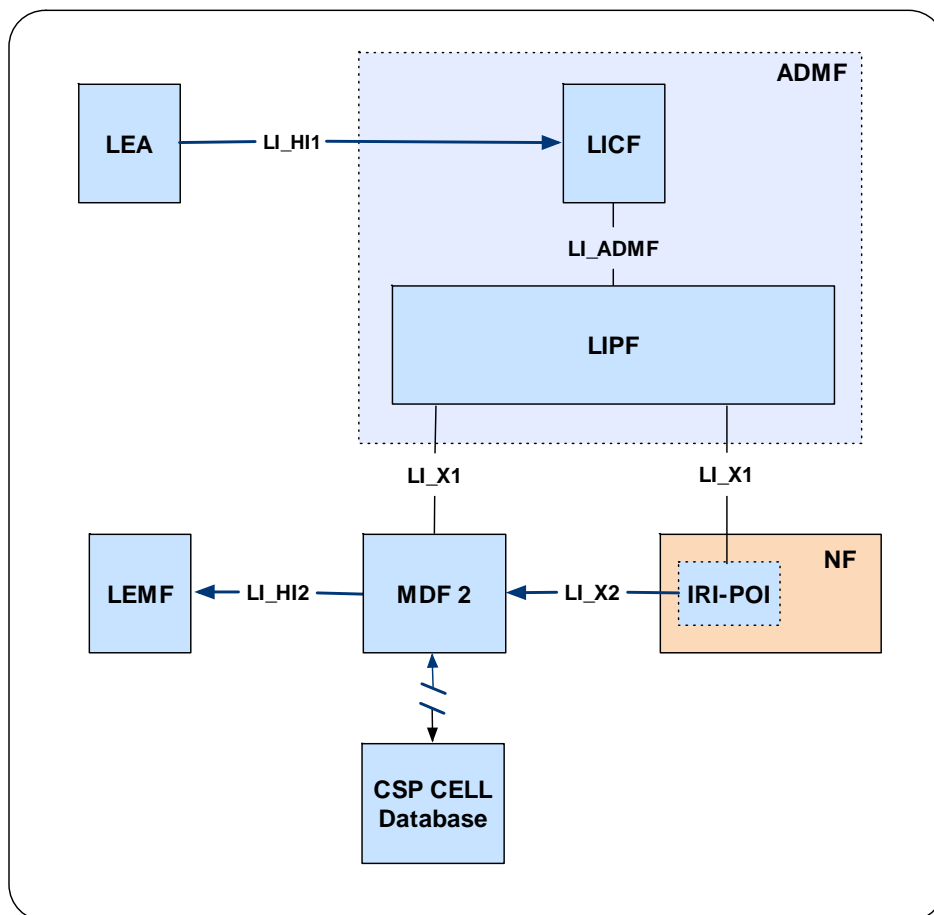

Figure 7.3.4-1: CSP cell database

## 7.4 IMS

### 7.4.1 General

Figure 7.4-1 depicts the EPS/5GS-Anchored IMS High Level LI Architecture.



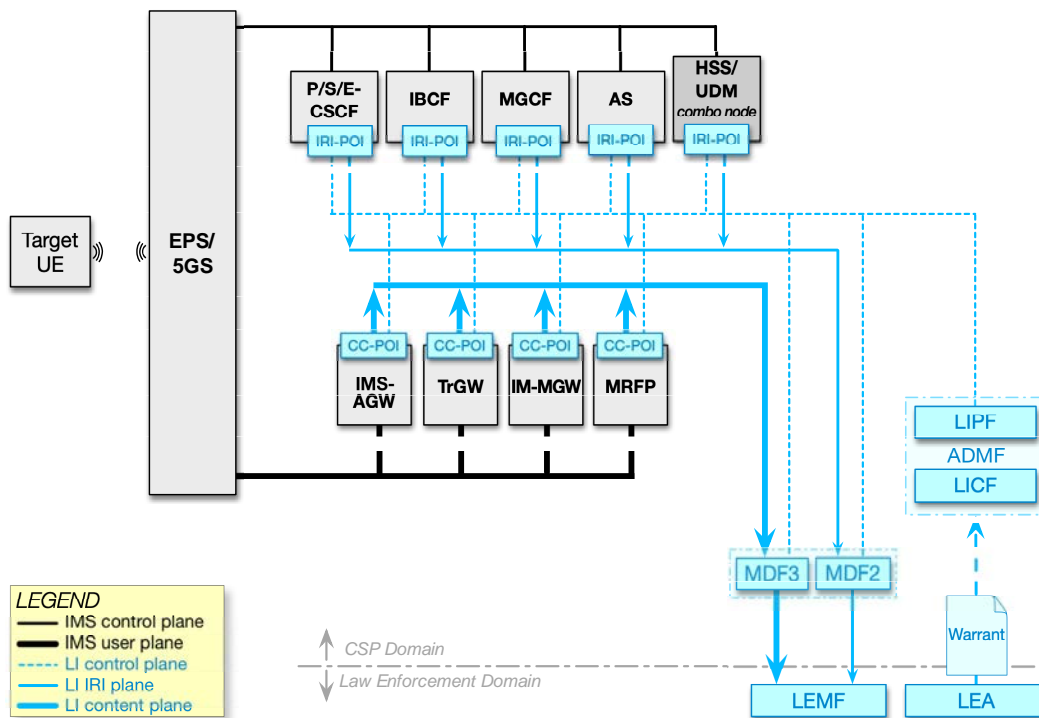

Figure 7.4-1: EPS/5GS-Anchored IMS High Level LI Architecture

## 7.4.2 Architecture

### 7.4.2.1 Overview

The capabilities defined in this clause apply to the interception of IMS-based services. The target of interception can be a subscriber of the CSP, an inbound roamer or a non-local ID.

The network function involved in providing the interception of IMS-based services are determined based on the deployment option, the network configuration, LI service scope and the IMS session including the roaming scenarios. The IRI-POI functions are provided by the network functions that handle the SIP messages (those network functions are referred to as IMS Signalling Functions) and the triggered CC-POI functions are provided by the network functions that handle the media (these network functions are referred to as IMS Media Functions). The CC-TF functions are also provided by the network functions that handle the SIP messages (referred to as IMS Signalling Functions) and manage the IMS Media Functions. The network functions that provide the CC-TF functions can be different from the network functions that provide the IRI-POI functions.

An architecture depicting the LI for IMS is depicted in figure 7.4-2 below.

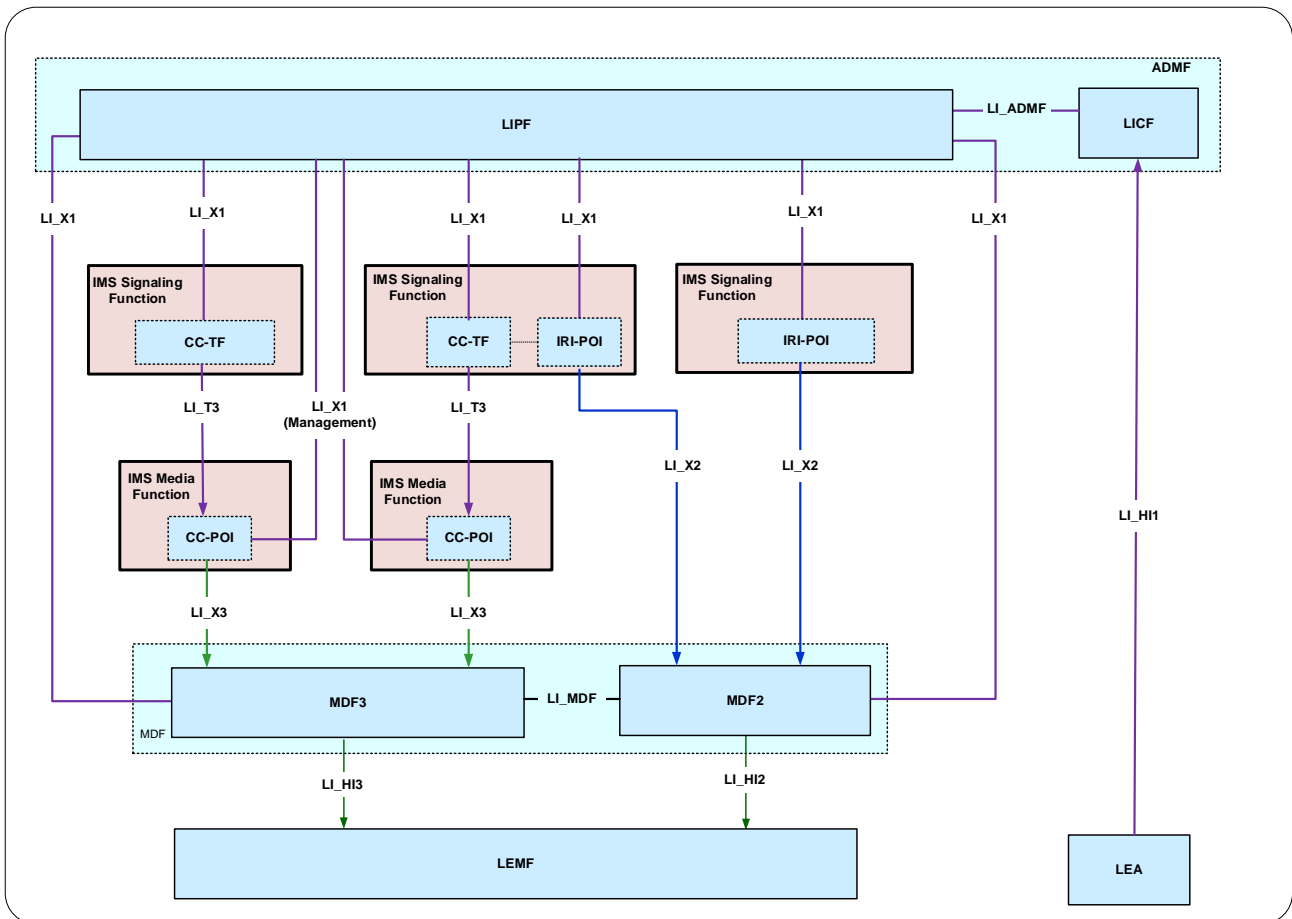

**Figure 7.4-2: IMS LI architecture**

The LICF present in the ADMF receives the warrant from an LEA, derives the intercept information from the warrant and provides it to the LIPF. The LIPF present in the ADMF provisions IRI-POI, CC-TF, MDF2 and MDF3 over the LI\_X1 interfaces.

The CC-TF sends the CC intercept trigger to the CC-POI over LI\_T3 interface. The IRI-POI generates the xIRI and delivers the same to the MDF2 over LI\_X2 interface. The CC-POI generates the xCC and delivers the same to the MDF3 over LI\_X3 interface.

The MDF2 generates IRI messages from the received xIRI and delivers those IRI messages to the LEMF over LI\_HI2 interface. The MDF3 generates the CC from the received xCC and delivers that CC to the LEMF over LI\_HI3 interface.

The network configuration and IMS service scenarios including the roaming scenarios determine the network functions that provide the IRI-POI, CC-TF and CC-POI functions. The network function that provides the IRI-POI or CC-TF is referred to as IMS Signalling Function in figure 7.4-2 and the network function that provides the CC-POI functions is referred to as IMS Media Function in figure 7.4-1.

**NOTE:** The details of correlation between the xIRI and the xCC when IRI-POI and CC-TF are not co-located is not defined in the present document. The IRI-POI and CC-TF are logical functions and they may be handled by the same process when they are co-located in the same IMS Signalling Function.

### 7.4.2.2 Target identities

The LIPF provisions the intercept related information associated with the following target identities to the IRI-POI and CC-TF present in the IMS Signalling Functions:

- IMPU.
- IMPI.
- PEI (IMEI only).

- IMEI.

The IRI-POI and CC-TF shall also support interception of non-local identities in any of the IMPU formats (SIP URI, TEL URI as well as the E.164 number in a SIP URI or TEL URI). In case a PBX is connected to a PLMN, the interception of targets that are served by PBX may be treated as non-local identities in the connected PLMN.

NOTE It is assumed that GPSI/MSISDN is mapped to IMPU, and SUPI/IMSI is mapped to IMPI.

### 7.4.2.3 Target identification

Depending on the session direction, different SIP parameters are used to identify the target subscriber.

Further details on the use of SIP parameters in identifying a target is described in TS 33.128 [15].

## 7.4.3 IRI-POI

### 7.4.3.1 General

The IRI-POI detects the SIP messages that are related to a target subscriber and then generates and delivers the related xIRI to the MDF2 over LL\_X2.

The following IMS Network Functions (i.e. IMS Signalling Functions) that handle SIP signalling for IMS sessions may provide the IRI-POI functions:

- S-CSCF.
- E-CSCF.
- P-CSCF.
- IBCF.
- MGCF.
- Conference AS/MRFC.
- Telephony AS.
- PTC server.

Clause 7.4.6 gives more information from network topology/session perspective how different IMS Network Functions are to be used in providing the IRI-POI functions. The Telephony AS is one of the IMS Network Functions that provides the IRI-POI for STIR/SHAKEN and RCD/eCNAM (see clause 7.14.2).

### 7.4.3.2 IRI events

The IRI-POI present in the IMS Signalling Function generates the following xIRI:

- Encapsulated SIP message.
- CC unavailable in serving PLMN.
- Start of interception with an established IMS session.

The encapsulated SIP message xIRI is generated and delivered to the MDF2 when the IRI-POI in the IMS Signalling Function detects that a SIP message is received from, or sent to, a target or processed on behalf of a target at the IMS Signalling Function.

The CC unavailable in PLMN xIRI is generated and delivered to the MDF2 for the session scenarios where access to the target media is not available to the CSP (see clause 7.4.7.1).

The start of interception with an established IMS session xIRI is generated when an interception is activated on an established IMS session. To support the possibility of generating such an xIRI, the IMS Signalling Function shall store and maintain the session related information including the media information for the life of all IMS sessions.

### 7.4.3.3 Common IRI parameters

The list of parameters in each xIRI are defined in TS 33.128 [15]. Each xIRI shall include at the minimum the following information:

- Target identity.
- Additional identities associated with the target as observed by the IRI-POI.
- Time stamp.
- Correlation information.

### 7.4.3.4 Specific IRI parameters

The parameters in each xIRI are defined in TS 33.128 [15].

## 7.4.4 CC-TF and CC-POI

### 7.4.4.1 General

The CC-TF detects the SIP messages that are related a target and then generates and sends a trigger to the CC-POI over the LI\_T3 reference point.

The CC-POI based on the trigger detects the media to be intercepted, generates the xCC and delivers the same to the MDF3.

The following IMS Network Functions (i.e. IMS Media Functions and IMS Signalling Functions) may provide the CC-POI and CC-TF functions:

- IMS-AGW with CC-TF in P-CSCF.
- TrGW with CC-TF in IBCF.
- IM-MGW with CC-TF in MGCF.
- MRFP with CC-TF in AS/MRFC (see NOTE 3).
- MRFP with CC-TF in Conference AS/MRFC (see NOTE 2).
- PTC Server with CC-TF in PTC Server (see NOTE 1).

Clause 7.4.6 gives more information from network topology/session perspective how different IMS Network Functions are to be used in providing the CC-TF/CC-POI functions.

NOTE 1: The PTC Server provides the IRI-POI and CC-POI functions, accordingly, PTC Server itself is the CC-TF.

NOTE 2: Conference AS, MRFC and MRFP together are referred to as Conference Server. Conference AS/MRFC provide the conference focus functions as defined in TS 24.147 [28].

NOTE 3: When music tone or announcement is given to the calling user prior to answer on an incoming call to the target.

### 7.4.4.2 CC intercept trigger

The CC-TF shall send CC intercept trigger to the CC-POI over LI\_T3. The CC intercept trigger, at the minimum, shall consist of the following:

- Correlation Identifier.
- Media Identifier (e.g. SDP information).

The Correlation Identifier is used to correlate the xCC with the corresponding xIRI and is delivered from the CC-POI over the LI\_X3 interface to the MDF3.

The Media Identifier is used to identify the media packets that have to be intercepted.

#### 7.4.4.3 Common CC parameters

For the delivery of intercepted media packets, the following information shall be passed from the CC-POI to the MDF3 in addition to the intercepted media packets:

- Target identity.
- Correlation identifier
- Time stamp.
- Direction (indicates media is from or to the target).

#### 7.4.5 Correlation of xCC and xIRI

The IRI messages derived from the xIRI and CC derived from xCC for a session shall be correlated to each other using the correlation information received in the xIRI and xCC. The details of this are specified in TS 33.128 [15].

#### 7.4.6 Network topologies

##### 7.4.6.1 General

The IMS Network Functions that provide the IRI-POI, CC-TF and CC-POI functions can vary based on the network topology and session scenarios such as:

- Network topologies:
  - Non-roaming.
  - Roaming case with Local Break Out (LBO), VPLMN.
  - Roaming case with LBO, HPLMN.
  - Roaming case with Home Routed (HR), VPLMN.
  - Roaming case with HR, in HPLMN.
- Session types:
  - Normal sessions.
  - Emergency sessions.
  - Redirected sessions.
  - IMS specific services such as conferencing, PTC, music, announcements.
  - SMS over IMS.
- Target type:
  - Non-local ID target.

A deployment option within the CSP may also have a role in selection of the Network Functions. In the case of roaming case, the interception performed in the VPLMN and HPLMN are based on separate independent warrants.

More detailed description of these scenarios is given in TS 33.128 [15].

### 7.4.6.2 IMS Network Functions providing the IRI-POI

The IMS Network Functions that handle the target side of the session provide the IRI-POI functions except when the alternate option is used for the non-local ID target. When the alternate option is used for the non-local ID target, the IMS network function that handles the session-leg of the local served user connected directly to the non-local ID target.

Table 7.4.6.2-1 below identifies the IMS Network Functions in providing the IRI-POI functions in a non-roaming case for various session scenarios.

**Table 7.4.6.2-1: IMS Network Functions providing the IRI-POI functions (non-roaming case)**

Session type/target type	Default	Alternative option
Normal sessions	S-CSCF	P-CSCF
SMS over IMS	S-CSCF	P-CSCF
Emergency sessions	E-CSCF	P-CSCF (NOTE 1)
SMS over IMS to emergency services	E-CSCF	P-CSCF (NOTE1)
Redirected sessions: intra-PLMN	S-CSCF	P-CSCF
Redirected sessions: inter-PLMN (CS domain)	S-CSCF	MGCF
Redirected sessions: inter-PLMN (IMS domain)	S-CSCF	IBCF
Conference (NOTE 2)	Conf-AS/MRFC	-
PTC	PTC-Server	-
Non-local ID in CS domain (NOTE 3, NOTE 3A)	MGCF	S-CSCF
Non-local ID in IMS domain (NOTE 3, NOTE 3A)	IBCF	S-CSCF
Non-local ID for SMS over IMS (NOTE 3)	S-CSCF	P-CSCF (NOTE 3A)

NOTE 1: For originated emergency sessions (or SMS over IMS to emergency services centre) handled in the fixed networks, where S-CSCF is also part of an emergency session, the S-CSCF based IRI-POI as a deployment option may also be considered.

NOTE 2: A conference ID can also be a target. Conf-AS stands for conference AS (see NOTE 2 in clause 7.4.4.1). When a normal session is extended to a conference session, the IMS signalling functions that provide the IRI-POI functions prior to the conference may continue to provide the IRI-POI functions in addition to the conference AS/MRFC.

NOTE 3: Non-roaming means that the local served user is non-roaming.

NOTE 3A: The default/alternate option used when the target is non-local ID is mutually independent of default/alternate option used when the target is local served user.

Table 7.4.6.2-2 below identifies the IMS Network Functions in providing the IRI-POI functions in a roaming case for various session scenarios.

**Table 7.4.6.2-2: IMS Network Functions providing the IRI-POI functions (roaming case)**

Session type/target type	Local Breakout (LBO)				Home Routed (HR)			
	HPLMN		VPLMN		HPLMN		VPLMN	
	Default	Alternate Option	Default	Alternate Option	Default	Alternate Option	Default	Alternate Option

Normal sessions	S-CSCF	IBCF	P-CSCF	-	S-CSCF	P-CSCF	N9HR/S8HR	-
SMS over IMS	S-CSCF	IBCF	P-CSCF	-	S-CSCF	P-CSCF	N9HR/S8HR	-
Emergency sessions/SMS over IMS	-	-	E-CSCF	P-CSCF	-	-	E-CSCF	P-CSCF
SMS over IMS to emergency services	-	-	E-CSCF	P-CSCF	-	-	E-CSCF	P-CSCF
Redirected sessions	S-CSCF	See table 7.4.6.2-3	-	-	S-CSCF	See table 7.4.6.2-3	-	-
Conference (NOTE 2)	Conf-AS/MRFC	-	-	-	Conf-AS/MRFC	-	-	-
PTC	PTC-Server	-	-	-	PTC-Server	-	-	-
Non-local ID (E.164) in CS domain (NOTE 3A, NOTE 4, NOTE 4A)	MGCF	S-CSCF	P-CSCF	IBCF (NOTE 4B)	MGCF	S-CSCF (NOTE 3A)	N9HR/S8HR	-
Non-local ID in SIP/IMS domain (NOTE 3A, NOTE 4, NOTE 4A)	IBCF	S-CSCF	P-CSCF	IBCF (NOTE 4B)	IBCF	S-CSCF (NOTE 3A)	N9HR/S8HR	-
Non-local ID for SMS over IMS (NOTE 4)	S-CSCF	IBCF	P-CSCF	-	S-CSCF	P-CSCF	N9HR/S8HR	-

NOTE 4: For roaming, this means the local served user is roaming. Also, see NOTE 3.

NOTE 4A: The default/alternate options used in the HPLMN and default/alternate options used in the VPLMN are mutually independent.

NOTE 4B: This alternate option may be used only in the VPLMN for IMS sessions with home-routed media.

The interception capabilities for normal sessions as defined in tables 7.4.6.2-1 (non-roaming) and 7.4.6.2-2 (roaming) shall be used for the cases where the Conf-AS and the PTSC-Server are not under the control of CSP serving the warrant.

**Table 7.4.6.2-3: Extension of table 7.4.6.2-2**

Session type/target type		Local Breakout (LBO)	Home Routed (HR)
Redirected sessions: Intra-PLMN	Redirected-to party non-roaming	P-CSCF	P-CSCF
	Redirected-to party is roaming	IBCF	P-CSCF
Redirected sessions Inter-PLMN	Redirected-to party in CS domain	MGCF	MGCF
	Redirected-to party in IMS domain	IBCF	IBCF

Table 7.4.6.2-3 shows the IMS Network Functions that provide the IRI-POI functions in the HPLMN for redirected sessions in a roaming case when the alternate option is used to provide the IRI-POI functions for the normal case.

NOTE 5: For the redirected do not answer related sessions, the IMS Network Functions that provide the IRI-POI functions prior to the redirection are as illustrated in table 7.4.6.2-2 (normal case) and after the redirection are as illustrated in table 7.4.6.2-3.

The IMS Network Functions that provide the IRI-POI for STIR/SHAKEN and RCD/eCNAM are listed in clause 7.14.2.

### 7.4.6.3 IMS Network Functions providing the CC-TF and CC-POI functions

The IMS Network Functions that handle the target side (including the non-local ID target) of the session provide the CC-TF and CC-POI functions. For redirected scenarios, the IMS Network Functions that handle the redirected-to-user side of the session provide the CC-TF and CC-POI functions.

Table 7.4.6.3-1 provides the IMS Network Functions that provide the CC-TF functions when the CC-POI functions are provided by the IMS Media Functions as indicated (also see clause 7.4.4.1).

**Table 7.4.6.3-1: Mapping between the IMS Network Functions providing the CC-TF and the CC-POI functions**

CC-POI	CC-TF
PGW (NOTE 1)	P-CSCF
PGW-U (NOTE 1)	P-CSCF
IMS-AGW	P-CSCF
MRFP	AS/MRFC
MRFP	Conference AS/MRFC
PTC-Server	PTC-Server
TrGW	IBCF
IM-MGW	MGCF

NOTE 1: This is defined in TS 33.107 [11] and outside the scope of the present document.

Table 7.4.6.3-2 below identifies the IMS Media Functions that provide the CC-POI functions in a non-roaming case for session scenarios (PGW and PGW-U based options are not shown in the table).

**Table 7.4.6.3-2: IMS Media Functions providing the CC-POI functions (non-roaming case)**

Session type/target type	CC-POI
Normal sessions	IMS-AGW
Emergency sessions	IMS-AGW
Redirected sessions: intra-PLMN	IMS-AGW
Redirected sessions: inter-PLMN (CS domain)	IM-MGW
Redirected sessions: inter-PLMN (IMS-domain)	TrGW
Music, announcement	MRFP
Conference (NOTE 4)	MRFP
PTC	PTC- Server
Non-local ID in CS domain (NOTE 2)	IM-MGW
Non-local ID in IMS domain (NOTE 2)	TrGW

NOTE 2: Non-roaming means that the local served user is non-roaming.

Table 7.4.6.3-3 below identifies the IMS Media Functions that provide the CC-POI functions in a roaming case for various session scenarios (PGW and PGW-U based options are not shown in the table).

**Table 7.4.6.3-3: IMS Media Functions providing the CC-POI functions (roaming case)**

Session type/target type	Local Breakout (LBO)			Home Routed (HR)	
	HPLMN	VPLMN		HPLMN	VPLMN
		Default	Alternate Option		



Normal sessions		TrGW	IMS-AGW	-	IMS-AGW	N9HR/ S8HR
Emergency sessions		-	IMS-AGW	-	-	IMS-AGW
Redirected sessions: intra-PLMN	Redirected-to-party non-roaming	IMS-AGW	-	-	IMS-AGW	-
	Redirected-to-party roaming	TrGW	-	-	IMS-AGW	-
Redirected sessions: inter-PLMN	Redirected-to-party in CS domain	IM-MGW	-	-	IM-MGW	-
	Redirected-to-party in IMS domain	TrGW	-	-	TrGW	-
Conference (NOTE 4)		MRFP	-	-	MRFP	-
Music, announcement		MRFP	-	-	MRFP	-
PTC		PTC-Server	-	-	PTC-Server	-
Non-local ID in CS domain (NOTE 3)		IM-MGW	IMS-AGW	TrGW (NOTE 5)	IM-MGW	N9HR/ S8HR
Non-local ID in IMS domain (NOTE 3)		TrGW	IMS-AGW	TrGW (NOTE 5)	TrGW	N9HR/S8HR

NOTE 3: Roaming means that the local served user is roaming.

NOTE 4: When a normal session is extended to a conference session, the IMS-AGW that provides the CC-POI functions prior to the conference may continue to provide the CC-POI functions as an alternate, or in addition, to the MRFP. In that case, the P-CSCF provides the CC-TF functions for the CC-POI in the IMS-AGW.

NOTE 5: This is applicable only for IMS sessions with home-routed media with a TrGW present in the VPLMN.

## 7.4.7 Roaming cases

### 7.4.7.1 Media unavailable in a roaming case

For roaming targets, depending on the roaming architecture deployed, media of the target may not enter the HPLMN for certain session scenarios. In such situations, the HPLMN served with the warrant shall be able to do the following:

- Perform the interception without the CC and report to the LEMF that the CC is unavailable due to target's roaming situation. Note that the Serving System message (reported by the UDM/HSS) also indicates to the LEMF that the target is roaming.
- When a new warrant is activated on a target with an ongoing IMS session with the CC not available, the HPLMN serving the new warrant shall report the CC unavailability indication to the LEMF associated with the new warrant.

See TS 33.128 [15] for the method used to report the CC unavailability indication.

### 7.4.7.2 S8HR

#### 7.4.7.2.1 Background

The term S8HR is used to denote the home-routed roaming architecture for VoEPS UEs. Within the VPLMN with S8HR, the IMS signalling messages are carried over the GTP tunnel that corresponds to the IMS signalling bearer and the media packets are carried over the GTP tunnel that corresponds to the media bearer. (i.e. a dedicated EPS Bearer is used to carry the media packets). The EPS Bearer ID of the IMS signalling bearer is always linked to the dedicated EPS Bearer used as a media bearer.

The SGW/PGW within the EPC may implement control plane and user plane functions in a combined form or in a separated form. In a separated form, the SGW-C/PGW-C provides the control plane functions and SGW-U/PGW-U provides the user plane functions.

NOTE: With S8HR, the PGW (or PGW-C/PGW-U) resides in the HPLMN.

#### 7.4.7.2.2 LI architecture

The present document specifies two options for implementing the LI functions for voice services with S8HR as the roaming architecture:

1. Use the capabilities specified below in the present document for stage 2 and in TS 33.128 [15] for stage 3.
2. Use the capabilities defined in TS 33.107 [11] and TS 33.108 [21] natively as defined in those documents.

According to the present document, to provide the lawful interception of voice services in the VPLMN with S8HR, the architecture presented in figure 7.4.7.4-1 is used with SGW-C providing the BBIFF-C and SGW-U providing the BBIFF-U functions.

NOTE 1: The overall architecture and functions related to the lawful interception of voice services of inbound roaming targets with S8HR as the roaming architecture is also referred in the present document as S8HR LI.

NOTE 2: The LI functions for SGW in a combined form can be visualized presuming that SGW-C and SGW-U are provided by the same network function. In this mode, the BBIFF-C and BBIFF-U functions are provided by BBIFF.

S8HR LI solution requires that Access Point Name (APN) can be identified as being used for S8HR and therefore can be used to identify that the EPS Bearers are used for inbound roamers with S8HR.

#### 7.4.7.2.3 S8HR LI Process

For the describing the S8HR LI process, the following terms apply:

- The packet data connection representing the IMS signalling channel referenced in clause 7.4.7.4.11 is referred to as IMS signalling bearer. This is also referred to as the default bearer and uses the QCI value of 5, GSMA IR.92 [26].
- The packet data connection representing the IMS media channel referenced in clause 7.4.7.4.11 is referred to as IMS media bearer. This is a dedicated bearer and uses the QCI value of 1 for voice media, GSMA IR.92 [26].
- The IMS signalling bearer and IMS media bearers are on separate GTP tunnels but are linked.

The S8HR LI process follows the steps described in clause 7.4.7.4.11 with the following specific aspects that apply to S8HR:

- The LIPF configures the BBIFF-C present in the SGW-C to notify the LMISF-IRI whenever an IMS signalling bearer or an IMS media bearer is created, modified, or deleted for S8HR inbound roaming UEs (i.e. the UEs that use S8HR APN).
- The BBIFF-C present in the SGW-C notifies the LMISF-IRI whenever it detects that such an IMS signalling bearer or an IMS media bearer is created, modified, or deleted.
- When the LMISF-IRI detects that IMS voice media interception is required, the LMISF-IRI instructs the BBIFF-C present in the SGW-C to deliver the user plane packets from the related IMS voice media bearer to the LMISF-CC.

NOTE 1: The LMISF-IRI includes the target UE location (when required) in the xIRI based on the UE location that it receives within the messages that denote the creation, modification, or deletion of IMS signalling or media bearers.

NOTE 2: When a target UE is involved in more than one IMS session, the release of an IMS session will not result in the BBIFF-U stopping the delivery of the user plane packets from the IMS media bearer since the IMS media bearer may still be active for that target UE.

#### 7.4.7.2.4 CC intercept trigger

The CC-POI and IRI-POI functions are provided by the embedded functions LMISF-CC and LMISF-IRI within the LMISF. As such the only interaction required between the two is to establish the correlation between the xCC and xIRI at an IMS session-leg level.

The LMISF-IRI instructs the BBIFF-C present in the SGW-C to deliver the user plane packets (to LMISF-CC) from the IMS media bearer linked to the IMS signalling bearer when it determines that an IMS session is associated with a target and requires CC interception. The BBIFF-C forwards the instruction along with the linked IMS signalling bearer information to BBIFF-U present in the SGW-U.

#### 7.4.7.2.5 S8HR LI and Target UE Mobility

During a session that involves the target UE, the SGW-C/SGW-U associated with the BBIFF-C/BBIFF U can change.

To support the continued interception of IMS sessions, the BBIFF-C in the new SGW-C notifies the LMISF-IRI that a BBIFF relocation has occurred.

The LMISF-IRI provides the functions described in clause 7.4.7.4.12 to support the continued and correlated interception for the CC.

NOTE: The LMISF should not disrupt the ongoing interception, if an IMS signalling bearer deletion notification is received from the BBIFF-C present in the old SGW-C.

#### 7.4.7.3 N9HR

##### 7.4.7.3.1 Background

The term N9HR is used to denote the home-routed roaming architecture for Vo5GS UEs. Within the VPLMN with N9HR, the IMS signalling messages and media packets are carried over the GTP tunnel that corresponds to the PDU session established for the UE for IMS based services.

The IMS signalling packets and the media packets are on separate Quality of Service (QoS) Flows with specific 5QI values (5QI = 5 for IMS signalling and 5QI = 1 for voice, GSMA NG.114 [27]). The H-SMF in the HPLMN assigns a separate QoS Flow Index (QFI) for IMS signalling related packets and IMS voice related packets. The UPF in the VPLMN can isolate the IMS signalling and media related packets from user plane packets based on the QFI value.

##### 7.4.7.3.2 LI architecture

To provide the lawful interception of voice services in the VPLMN with N9HR, the architecture presented in figure 7.4.7.4-1 is used with SMF providing the BBIFF-C and UPF providing the BBIFF-U functions.

NOTE: The overall architecture and functions related to the lawful interception of voice services of inbound roaming targets with N9HR as the roaming architecture is also referred in the present document as N9HR LI.

N9HR LI requires that a Data Network Name (DNN) can be identified as being used for N9HR and therefore can be used to identify that PDU sessions are used for inbound roamers with N9HR.

The BBIFF-C and BBIFF-U functions are provided by adopting a subset of LI functions defined for LI at SMF/UPF as defined in clause 6.2.3 and TS 33.128 [15].

##### 7.4.7.3.3 N9HR LI Process

For the purposes of describing the N9HR LI process, the following terms apply:

- The packet data connection representing the IMS signalling channel referenced in clause 7.4.7.4.11 is referred to as PDU session with IMS signalling related QoS flow.
- The packet data connection representing the IMS media channel referenced in clause 7.4.7.4.11 is referred to as PDU session with IMS media related QoS flow.

The IMS signalling and the IMS voice media are on the same PDU session.

NOTE 1: The QoS flow associated with the IMS signalling related user plane packets have the 5QI value 5, GSMA NG.114 [27] and such user plane packets can be identified at the BBIFF-U in UPF with the assigned QFI value.

NOTE 2: The QoS flow associated with the IMS voice media related user plane packets have the 5QI value 1, GSMA NG.114 [27] and such user plane packets can be identified at the BBIFF-U in UPF with the assigned QFI value.

The N9HR LI process follows the steps described in clause 7.4.7.4.11 with the following specific aspects that apply to N9HR:

- The LIPF configures the BBIFF-C present in the SMF to notify the LMISF-IRI whenever a PDU session is created, modified, or deleted for inbound roaming UEs with an N9HR DNN.
- The BBIFF-C present in the SMF notifies the LMISF-IRI whenever it detects that a PDU session is created, modified, or deleted for inbound roaming UEs with N9HR DNN. The UE location information and the PDU session ID is included in such notifications.
- When the LMISF-IRI determines that IMS voice media interception is required, the LMISF-IRI instructs the BBIFF-C present in the SMF with the PDU session information that the IMS voice media related user plane packets from that PDU session are to be delivered to LMISF-CC.

NOTE 3: The LMISF-IRI includes the target UE location (when required) in the xIRI based on the UE location that it receives within the messages that denote the creation, modification, or deletion of the PDU session.

NOTE 4: When a target UE is involved in more than one IMS session, the release of an IMS session will not result in the BBIFF-U stopping delivery of IMS media related user plane packets since the IMS media related QoS Flow may still be active within the PDU session.

#### 7.4.7.3.4 CC intercept trigger

The CC-POI and IRI-POI functions are provided by the embedded functions LMISF-CC and LMISF-IRI within the LMISF. As such the only interaction required between the two is to establish the correlation between the xCC and xIRI at an IMS session-leg level.

The LMISF instructs the BBIFF-C present in the SMF to deliver to (to LMISF-CC) the IMS voice media related user plane packets from the PDU session associated with the intercepted IMS session. The BBIFF-C present in the SMF forwards the instruction along with the PDU session information to BBIFF-U present in the UPF.

#### 7.4.7.3.5 N9HR LI and Target UE Mobility

During a session that involves the target UE, the SMF that has the BBIFF-C, or the UPF that has the BBIFF-U can change.

To support the continued interception of IMS sessions, the BBIFF-C in the new SMF notifies the LMISF-IRI that a BBIFF (i.e., SMF or UPF) relocation has occurred.

The LMISF-IRI provides the functions described in clause 7.4.7.4.12 to support the continued and correlated interception of CC.

NOTE: The LMISF should not disrupt the ongoing interception, if a PDU session deletion related notification is received from the BBIFF-C present in the old SMF.

#### 7.4.7.4 LI in VPLMN with home-routed roaming architecture

##### 7.4.7.4.1 Background

With home-routed roaming architecture, all the IMS Signalling Functions and IMS Media Functions reside in the HPLMN. National regulations may still require the VPLMN to have the capabilities to perform the lawful interception of voice services involving the inbound roaming targets. The LI capabilities provided in the VPLMN with home-routed roaming architecture shall be to the same extent as the LI capabilities provided in the VPLMN with LBO approach as the roaming architecture.

The IMS signalling messages are exchanged between the UE and the P-CSCF (in HPLMN) and the media is exchanged between the UE and the IMS-AGW (in HPLMN).

#### 7.4.7.4.2 LI architecture

To provide the lawful interception of voice services in the VPLMN with home-routed roaming architecture, new LI-specific functions are introduced to examine the packets that flow through the VPLMN packet core network functions in order to generate IRI and CC when the communication involves an inbound roaming target.

Figure 7.4.7.4-1 shown below illustrates a generic LI architecture for home-routed roaming architecture in the VPLMN.

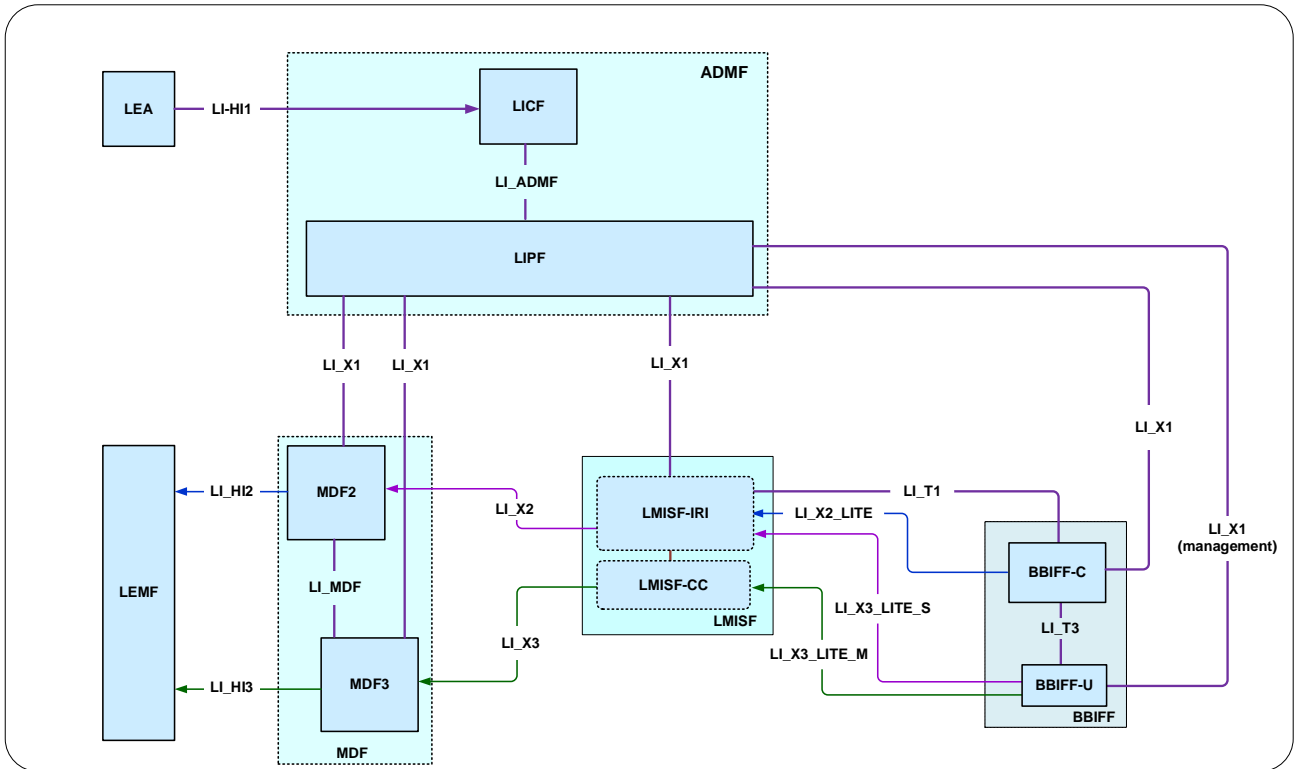

**Figure 7.4.7.4-1: VPLMN generic LI architecture for home-routed roaming**

NOTE: See clause 7.4.7.4.10 for brief descriptions of the LI functions and interfaces depicted in figure 7.4.7.4-1.

#### 7.4.7.4.3 Target identifiers

The target identifiers used for inbound roaming UEs are same as the identifiers used for IMS sessions in the VPLMN with LBO as the roaming architecture. See clause 7.4.2.2 for further details.

#### 7.4.7.4.4 Target identification

Depending on the session direction, different SIP parameters are used to identify the target. The SIP parameters used to identify the target can be different from the SIP parameters used to identify a target at the P-CSCF (with LBO as the roaming architecture).

Further details on the use of SIP parameters in identifying a target are described in TS 33.128 [15].

#### 7.4.7.4.5 IRI events

The IRI events are same as the xIRI defined for IMS sessions in the VPLMN with LBO as the roaming architecture. See clause 7.4.3.2 for details.

#### 7.4.7.4.6 IRI parameters

The IRI parameters are the same as those defined for IMS sessions in the VPLMN with LBO as the roaming architecture. See clauses 7.4.3.3 and 7.4.3.4 for details.

#### 7.4.7.4.7 CC intercept trigger

The LMISF-IRI instructs the BBIFF-C (over the LI\_T1 interface) to deliver the IMS media packets when it determines that an IMS session is associated with a target and requires CC interception. The BBIFF-C forwards the instruction to BBIFF-U over the LI\_T3 interface.

#### 7.4.7.4.8 CC parameters

The CC parameters are the same as those defined for IMS sessions in the VPLMN with LBO as the roaming architecture. See clause 7.4.4.3 for details.

#### 7.4.7.4.9 Correlation of xCC and xIRI

The LMISF assigns the correlation number for an IMS session and uses the same correlation number in the associated xIRI and xCC. The interaction between the LMISF-IRI that generates the xIRI and LMISF-CC that generates the xCC is an internal function of LMISF.

#### 7.4.7.4.10 LI specific functions and interfaces

The additional LI specific functions and interfaces introduced to support the LI with home-routed roaming architecture shown in figure 7.4.7.4-1 are listed below:

- LMISF (LI Mirror IMS State Function): A logical LI specific function that provides the IMS state function for LI purposes. The LMISF provides the IRI-POI and CC-POI functions. The LMISF also initiates the required trigger for IMS media interception. The LMISF may be viewed as consisting of two embedded functions: 1) LMISF-IRI (handling the IMS signalling related LI functions, i.e. IRI-POI), 2) LMISF-CC (handling the IMS media related LI functions, i.e. CC-POI). The interface between the two embedded functions is not defined.

NOTE 1: The present document assumes one LMISF per VPLMN for a given roaming agreement.

NOTE 2: The term LMISF is used when a description applies to LMISF-IRI or LMISF-CC.

- BBIFF (Bearer Binding Intercept and Forward Function): Binds the IMS signalling and media to the LMISF for interception purpose. The BBIFF may be split into two BBIFF-C and BBIFF-U, with the former present in the NF that provides the control plane related functions and the latter present in the NF that provides the user plane related functions associated with the inbound roaming UEs.
- LI\_X2\_LITE: Used to carry the control plane information (e.g. packet data connection related notifications, UE location) from BBIFF-C to LMISF-IRI.
- LI\_X3\_LITE\_S: Used to forward the IMS signalling related user plane packets of inbound roaming UEs from BBIFF-U to the LMISF-IRI.
- LI\_X3\_LITE\_M: Used to forward the IMS media related user plane packets of inbound roaming target UE from BBIFF-U to the LMISF-CC.
- LI\_T1: Used to instruct the BBIFF-C that user plane packets of the associated IMS media need to be captured and delivered to the LMISF-CC.
- LI\_T3: Used to instruct the BBIFF-U to capture and deliver the selective user plane packets of inbound roaming UEs to the LMISF.

The user plane packets reported by BBIFF-U include the IMS signalling related packets and IMS media related packets. A condition required for this LI architecture is that LMISF shall have access to the IMS signalling messages and the IMS media packets in an unencrypted form.

NOTE 3: The LI functions available within the VPLMN network functions that have access to the packet data connections that carry the IMS signalling and IMS media may be used to provide the BBIFF-C, BBIFF-U functions.

#### 7.4.7.4.11 LI Process

The following steps happen for all home-routed inbound roaming UEs irrespective of whether those UEs are associated with a target:

- The LIPF configures the BBIFF-C (over LI\_X1 interface) to notify the LMISF-IRI whenever home-routed inbound roaming UEs establish, modify or delete the IMS signalling and the IMS media channels. The UE exchanges the IMS signalling messages with the P-CSCF residing in the HPLMN over the IMS signalling channel and IMS media with the IMS-AGW residing in the HPLMN over the IMS media channel. The LIPF also provides the same information to LMISF-IRI (over LI\_X1 interface) in order to let it know the notifications to be expected from the BBIFF-C.

NOTE 1: The term *channel* is a generic term used in this description to represent IMS signalling or media related packet data connection within a PDN (Packet Data Network) connection.

- The BBIFF-C notifies the LMISF-IRI (over LI\_X2\_LITE interface) whenever the IMS signalling channel or the IMS media channel is established, modified or deleted for home-routed inbound roaming UEs. The UE location information is included in such notifications. The BBIFF-C instructs the BBIFF-U (over LI\_T3 interface) to deliver the appropriate IMS signalling related user plane packets to the LMISF-IRI.
- The BBIFF-U delivers the IMS signalling related user plane packets to the LMISF-IRI (over the LI\_X3\_LITE\_S interface).

The following steps are performed for the target UEs:

- The LIPF provisions the LMISF-IRI, MDF2 and MDF3 (over LI\_X1 interface) with the IMS target information.
- When the received user plane packets from the BBIFF-U represent IMS signalling messages associated with a target, the LMISF-IRI generates the xIRI and delivers them to the MDF2 over the LI\_X2 interface.
- Upon identifying that IMS signalling messages are associated with a target that requires CC interception, the LMISF-IRI instructs the BBIFF-C (over LI\_T1 interface) that the user plane packets that represent associated IMS media (i.e. from the IMS media channel associated with the IMS signalling channel) are to be delivered to LMISF-CC.
- The BBIFF-C instructs the BBIFF-U (over LI\_T3 interface) to deliver user plane packets that represent the associated IMS media to the LMISF-CC.
- The BBIFF-U delivers the indicated user plane packets that represent the IMS media to the LMISF-CC (over LI\_X3\_LITE\_M interface). The LMISF-CC generates xCC from the received IMS media related user plane packets and delivers them to the MDF3 over LI\_X3 interface along with the information that correlates the xCC with the xIRI.

NOTE 2: LMISF-CC interacts with the LMISF-IRI to correlate the xCC with the xIRI.

- When all IMS sessions for a target UE have ended, LMISF-IRI instructs the BBIFF-C (over LI\_T1 interface) to stop the delivery of IMS media related user plane packets. Upon receiving such a notification, the BBIFF-C instructs the BBIFF-U (over LI\_T3 interface) to stop the delivery of the IMS media related user plane packets to the LMISF-CC.

NOTE 3: In the above steps, BBIFF-C and BBIFF-U functions are not aware of any IMS target information (i.e. SIP URI or TEL URI).

NOTE 4: The LMISF-IRI includes the target UE location (when required) in the xIRI based on the UE location that it receives from the BBIFF-C.

The LMISF-IRI stores the IMS signalling messages received from the BBIFF-U for a potential future LI activation (i.e. mid-call interception). Furthermore, the xCC generated from the IMS media related user plane packets may be associated with different session-legs, and hence may have different correlation numbers.

When the inbound roaming UE deregisters for the IMS signalling (i.e. with HPLMN), the LMISIF shall ensure that deregistration is mirrored in its own maintained state for that UE.

#### 7.4.7.4.12 Target UE Mobility

During a session that involves the target UE, the network function associated with the BBIFF-C, or the BBIFF U can change. The lawful interception of IMS sessions involving a target shall continue when such a relocation happens. The xIRI and xCC delivered before and after the relocation shall be correlated.

To support the continued interception of IMS sessions, the BBIFF-C in the new network function notifies the LMISF-IRI (over LI\_X2\_LITE interface) that a BBIFF relocation has occurred.

The LMISF-IRI provides the following functions to support the continued and correlated interception of CC:

- When a notification is received from the BBIFF-C that a BBIFF relocation has occurred, examine to see whether any IMS session is setup for the UE and is being intercepted.
- If an intercepted IMS session is setup, examine to see whether a CC interception for that IMS session is required.
- If the intercepted IMS session requires CC interception, inform the new BBIFF-C (over the LI\_T1 interface) with an instruction that the user plane packets that represent associated IMS media are to be delivered to LMISF-CC.

Further handling of CC interception is as defined in clause 7.4.7.4.11.

## 7.5 MMS

### 7.5.1 Overview

MMS service is defined in TS 22.140 [19], OMA's MMS Architecture OMA-AD-MMS-V1\_3-20110913-A [17], and OMA's Multimedia Messaging Service Encapsulation Protocol OMA-TS-MMS\_ENC-V1\_3-20110913-A [18].

In a 3GPP network, the MMS Proxy-Relay handles the MMS related functions. More specifically, the MMS Proxy-Relay is responsible for:

- 1) receiving an MMS from a served UE and forwarding that to the MMS Proxy-Relay of the destination UE;
- 2) receiving an MMS from an originating MMS Proxy-Relay and forwarding this MMS or a notification of it to its served UE;
- 3) receiving a request for retrieval of an MMS from a served UE and delivering that MMS to the served UE;
- 4) providing the served UE with delivery status and read reports of served UE originated MM;
- 5) providing an MMS/Relay of another UE with delivery status and read reports of MMS received for the served UE.

### 7.5.2 LI at MMS Proxy-Relay

#### 7.5.2.1 Architecture

The MMS Proxy-Relay shall have LI capabilities to generate the target UE's MMS related xIRI and xCC.

The IRI-POI present in the MMS Proxy-Relay detects the MMS related events, generates and delivers the related xIRI to the MDF2 over LI\_X2. The MDF2 delivers the IRI messages to the LEMF over LI\_HI2.

When interception of communication contents is required, the CC-POI present in the MMS Proxy-Relay generates the xCC from the MMS messages and delivers the xCC (that includes the correlation number and the target identity) to the MDF3. The MDF3 delivers the CC to the LEMF over LI\_HI3.

#### 7.5.2.2 Target Identities

The LIPF provisions the intercept related information associated with the following target identities to the IRI-POI/CC-POI present in the MMS Proxy-Relay:



- Email Address.
- GPSI.
- IMPI.
- IMPU.
- IMSI.
- SUPI.

The interception performed on the above identities are mutually independent, even though, an xIRI may contain the information about the other identities when available. The IRI-POI and CC-POI present in the MMS Proxy-Relay shall also support interception of non-local identities in any of the IMPU formats (SIP URI, TEL URI as well as the E.164 number in a SIP URI or TEL URI), GPSI formats (E.164 number, external identifier) and email address.

### 7.5.2.3 IRI Events

The IRI-POI present in the MMS Proxy-Relay shall generate xIRI, when it detects the following specific events or information:

- An MMS message is sent by the target or sent to the target.

### 7.5.2.4 Common IRI parameters

The list of xIRI parameters are specified in TS 33.128 [15]. Each xIRI shall include at the minimum the following information:

- Target identity.
- Time stamp.
- Correlation information (when xCC is also reported).
- MMS related information.

### 7.5.2.5 Specific IRI parameters

The parameters in each xIRI are defined in TS 33.128 [15].

### 7.5.2.6 CC

The MMS xCC is generated when the CC-POI in the MMS Proxy-Relay detects that CC related to an MMS message is either received from the target, sent to the target, or stored on behalf of the target.

### 7.5.2.7 Network Topologies

LI at the MMS Proxy-Relay is only applicable at the HPLMN.

## 7.6 PTC service

### 7.6.1 General

In the present clause, "PTC" will be used to reference events or services that occur in either of two different architectures unless specified otherwise, e.g., Mission Critical Push To Talk (MCPTT) or Push to talk over Cellular (PoC).

The following servers support PTC architecture:

- MCPTT servers (Including Common services core as defined in TS 23.280 [24]).

- PoC servers (Including Shared XDMS as defined in OMA-AD-PoC-V2\_1-20110802-A [25]).

The PTC server will be used to represent the MCPTT server or PoC server for group communication services.

If two or more different parties involved in a PTC communication are each a target of interception, each interception shall operate independently of the others and the results of each intercept shall be delivered to the respective LEMF in accordance with the applicable warrant.

## 7.6.2 Target identities

A provisioned target identity can be the following:

- MCPTT ID.
- Instance Identifier URN.
- IMPU.
- IMPI.
- PTC Chat GroupID.

The interception performed on the above identities are mutually independent, even though, an xIRI may contain the information about the other identities when available.

## 7.6.3 IRI events

The IRI-POI present in the PTC Server shall generate xIRI when it detects the following specific events or information:

- PTC service registration.
- PTC session initiation.
- PTC session abandon.
- PTC session start.
- PTC session end.
- PTC start of interception.
- PTC pre-established Session.
- PTC instant personal alert.
- PTC party join.
- PTC party drop.
- PTC party hold.
- PTC media modification.
- PTC group advertisement.
- PTC floor control.
- PTC target presence.
- PTC associate presence.
- PTC list management.
- PTC access policy.

The events above trigger the transmission of information from the IRI-POI to the MDF2.

## 7.6.4 Common IRI parameters

Each xIRI shall include at the minimum the following information:

- Target identity.
- Time stamp.
- Correlation information.
- Location information (if required and available).
- PTC related information (e.g., PTC group ID, PTC party).
- Encryption parameters (if required and available).
- Direction (floor control source or destination port).

## 7.6.5 Specific IRI parameters

The parameters in each xIRI are defined in TS 33.128 [15].

## 7.6.6 Common CC parameters

In addition to the intercepted content of communications, the following information needs to be transferred from the CC-POI to the MDF3 in order to allow the MDF3 to perform its functionality:

- Target identity.
- Correlation information.
- Time stamp.
- Identity of source of media (communications content) for group call.

## 7.6.7 Specific CC parameters

The parameters in xCC are defined in TS 33.128 [15].

## 7.6.8 Network topologies

The PTC server resides in the home network and shall provide IRI-POI and CC-POI functionality.

# 7.7 Identity Caching Function

## 7.7.1 General

The ICF is responsible for receiving identity caching events from all IEFs in the network over the LI\_XER interface and handling queries from the IQF over the LI\_XQR interface to the IQF as defined in clause 5.7.

The temporary cache duration shall be configurable by the LICF on a per CSP network basis.

NOTE: The terms identifier and identity are used interchangeably in clause 7.7. This also applies to the naming of functions like IQF.

## 7.7.2 ICF Query Identities

The IQF present in the ADMF shall be able to query the records held by the ICF using one of the following target identifiers:

- SUPI.
- SUCI.
- 5G-S-TMSI.
- 5G-GUTI.

NOTE: Targeting based on GPSI, PEI, IMS identifiers or other legacy identifiers (e.g. MSISDN) is not supported by the present document.

The list of event parameters is specified in TS 33.128 [15]. Each event shall include at the minimum the following information:

- Query target identifier.
- Time of target identifier observation.

For queries based on temporary identifiers the following additional information shall be included:

- Tracking area identifier.
- Cell identity.

### 7.7.3 ICF Response parameters

The list of event parameters is specified in TS 33.128 [15]. Each event shall include at the minimum the following information:

- Subscription permanent identifier.
- Related temporary identifier(s).
- Start of validity timestamp(s).
- End of validity timestamp(s).

The following additional information shall be included if it was available in the IEF records provided to the ICF:

- Permanent equipment identifier (PEI).
- Generic Public Subscription Identifier (GPSI).

The following additional information shall be included when available and if requested in the IQF to ICF query:

- Location information (i.e. Cell identity and tracking area identifier).

### 7.7.4 Network topologies

Since the ICF caches events independently of network topology for individual service usage UEs, no specific network topology handling is provided by the ICF. The IQF shall be responsible for handling any network topology requirements that may be applied by the LEA in an individual warrant.

## 7.8 Non-IP data delivery (NIDD) in 5GS

### 7.8.1 Background

#### 7.8.1.1 General

Functions for NIDD (Non-IP Data Delivery) may be used to handle Mobile Originated (MO) and Mobile Terminated (MT) communication for unstructured data (also referred to as Non-IP). Such delivery to an AF is accomplished by one of the following two mechanisms (see TS 23.501 [2] clause 5.31.5):

- Delivery using NEF.
- Delivery using UPF via a Point-to-Point (PtP) N6 tunnel.

If the subscription includes a "NEF Identity for NIDD" corresponding to the DNN and S-NSSAI information, then the SMF selects that NEF as the anchor of this PDU session, otherwise, the SMF selects a UPF as the anchor of this PDU session. If NEF is used, the NIDD traffic is forwarded by NEF to the AF. If UPF is used, the NIDD traffic is forwarded by UPF to the AF.

NIDD applies to non-roaming and roaming with home-routed roaming architecture.

## 7.8.1.2 NIDD in non-roaming situation

### 7.8.1.2.1 Delivery using NEF

Figure 7.8-1 presents the architecture for delivery of NIDD using NEF in non-roaming scenario. NIDD using NEF requires a control plane PDU session. The PDU session is established between UE and NEF via AMF and SMF. The user traffic is exchanged with DoNAS (Data over NAS) between UE and AMF, then over N11 interface between AMF and SMF, then over N29 interface between SMF and NEF and finally over N33 interface between NEF and AF (see TS 23.502 [4] clause 4.25).

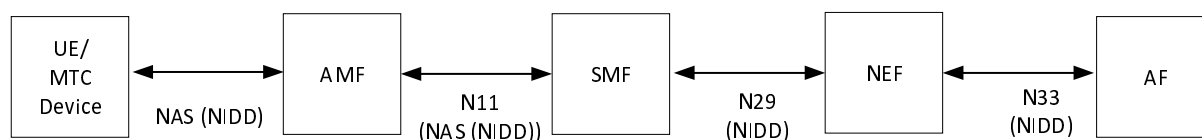

**Figure 7.8-1: 5GS Architecture for NIDD using NEF**

### 7.8.1.2.2 Delivery using UPF via a PtP N6 tunnel

Figure 7.8-2 shows the architecture for delivery of NIDD using UPF via a PtP N6 tunnel in non-roaming scenario. The user traffic is exchanged with DoNAS between UE and AMF, over N11 interface between AMF and SMF, over N4 interface between SMF and UPF and finally over PtP N6 tunnel between UPF and AF. The tunnel is typically a UDP/IP tunnel.

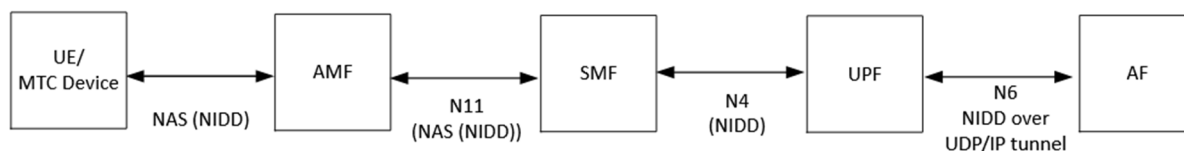
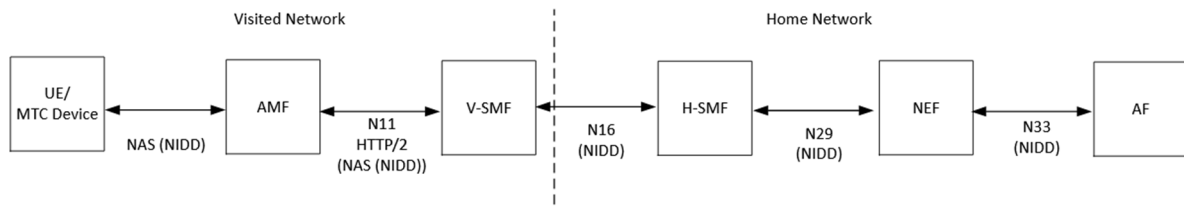

**Figure 7.8-2: 5GS Architecture for NIDD using a PtP N6 tunnel**

## 7.8.1.3 NIDD in roaming situation

### 7.8.1.3.1 Delivery using NEF

In roaming scenario, the PDU session for NIDD using NEF is established between the UE and NEF via V-AMF, V-SMF and H-SMF. The user traffic is exchanged with DoNAS between UE and AMF, then over N11 interface between AMF and V-SMF, over N16 interface between V-SMF and H-SMF and over N29 interface between SMF and NEF and finally over N33 interface between NEF and AF. Figure 7.8-3 shows the architecture for delivery of NIDD using NEF in roaming situation.



**Figure 7.8-3: 5GS Architecture for NIDD using NEF in roaming situation**

### 7.8.1.3.2 Delivery using UPF via a PtP N6 tunnel

In roaming scenario, the user traffic is exchanged with DoNAS between UE and AMF, over N11 interface between AMF and V-SMF, over N4 interface between V-SMF and V-UPF, over N9 between V-UPF and H-UPF and finally over PtP N6 tunnel between H-UPF and AF (figure 7.8-4).

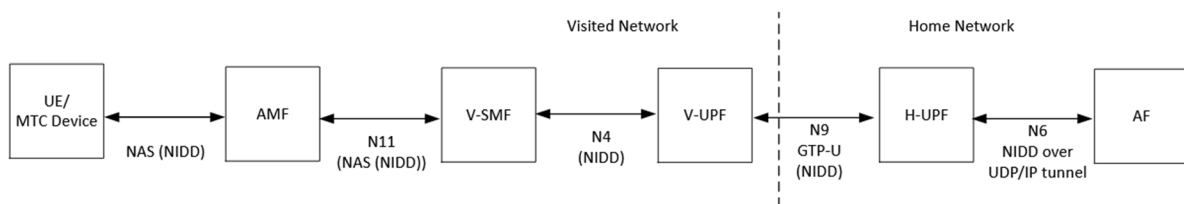

**Figure 7.8-4: 5GS Architecture of NIDD using a PtP N6 tunnel in roaming situation**

## 7.8.2 LI for NIDD

### 7.8.2.1 LI for NIDD using NEF

#### 7.8.2.1.1 General

In non-roaming scenario, only NEF will provide IRI-POI and CC-POI.

In roaming scenario, V-SMF shall provide the IRI-POI and CC-POI functions for the visited network while NEF in the home network provides IRI-POI and CC-POI.

**NOTE:** Only home-routed mode applies.

LI for NIDD using NEF in the VPLMN is described in clause 7.8.2.1.2. LI for NIDD using NEF in the HPLMN is described in clause 7.9.2.1.

Packet header reporting, non-3GPP access and MA-PDU session are not applicable to NIDD.

#### 7.8.2.1.2 Architecture for NIDD using NEF in the VPLMN

This clause describes the LI for NIDD using NEF in the VPLMN. The access method for the delivery of xCC related to NIDD using NEF is based on duplication of packets without modification of the packets at the V-SMF (in case of roaming) and NEF in the home network. The duplicated packets with additional information in a header are sent to MDF3 via LI\_X3 for further delivery to the LEMF via LI\_HI3. Figure 7.8-5 gives a reference point representation of the LI architecture with V-SMF as a CP NF and UP NF providing the IRI-POI and CC-POI functions for NIDD using NEF in the visited network.

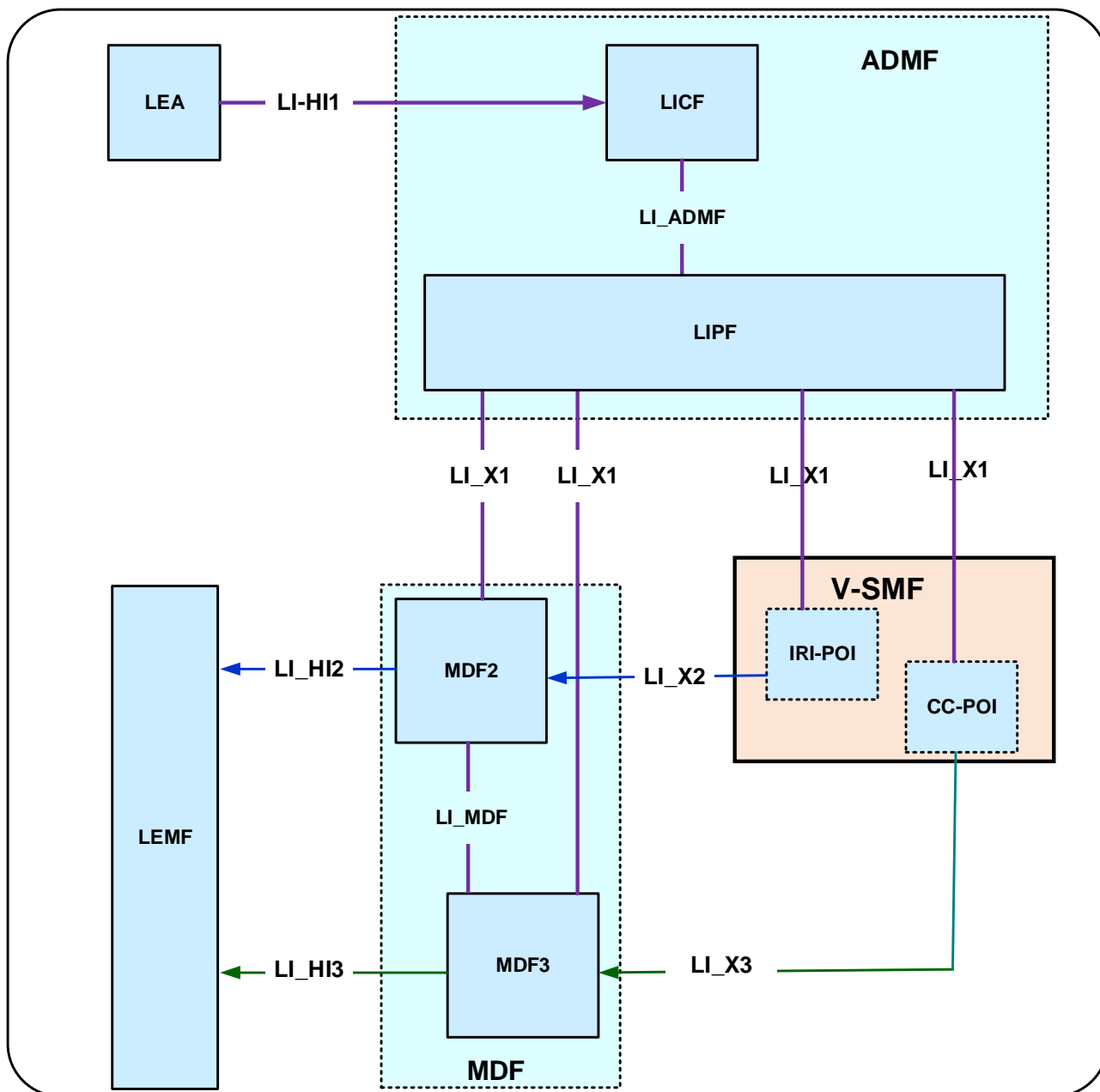

Figure 7.8-5: LI architecture for NIDD using NEF showing LI at V-SMF

7.8.2.1.3 Target identifiers

The LIPF present in the ADMF provisions the intercept information associated with the following target identities to the IRI-POI present in the AMF:

- SUPI.
- PEI.
- GPSI.

The interception performed on the above three identities are mutually independent, even though, an xIRI may contain the information about the other identities when available.

7.8.2.1.4 IRI events

The IRI-POI present in the V-SMF handles the same records included in xIRIs for NIDD using NEF as those identified in clause 6.2.3.3:

- PDU session establishment.
- PDU session modification.
- PDU session release.
- Start of interception with established PDU session.
- Unsuccessful procedure.

For NIDD using NEF with or without roaming situation, the IRI-POI present in the H-SMF shall avoid generating xIRIs since NEF always provides the xIRIs for the home network.

### 7.8.2.2 LI for NIDD using a PtP N6 tunnel

In non-roaming scenario, the SMF will provide an IRI POI while UPF shall include a CC-POI.

In roaming scenario, V-SMF and H-SMF shall provide the IRI-POI and V-UPF and H-UPF shall include the CC-POI function as shown in figure 6.2-4 which also concerns IRI-POI and CC-POI functions for IP-based and Ethernet-based PDU sessions.

NOTE: Only home-routed mode applies.

The LI architecture for SMF/UPF for NIDD using a PtP N6 tunnel is the same as presented in figure 6.2-4.

However, the user plane packets between UE and UPF flow through the SMF as shown in figures 7.8-2 and 7.8-4.

The same xIRIs defined in clause 6.2.3.3. for PDU sessions of IP or Ethernet type and the same xCC are also considered for PDU sessions for NIDD using a PtP N6 tunnel, considering unstructured payload format.

## 7.9 LI at NEF

### 7.9.1 General

The present document specifies NEF as POI for:

- NIDD.
- Device triggering.
- MSISDN-less MO SMS.
- Parameter provisioning.

### 7.9.2 LI for NIDD using NEF

#### 7.9.2.1 Architecture

The NEF shall provide both IRI-POI and CC-POI functions. Figure 7.9-1 gives a reference point representation of the LI architecture with NEF as a CP NF and UP NF providing the IRI-POI and CC-POI functions. NEF is the anchor point for PDU session establishment and NIDD traffic. The NIDD traffic is forwarded by NEF to the AF over the N33 interface.



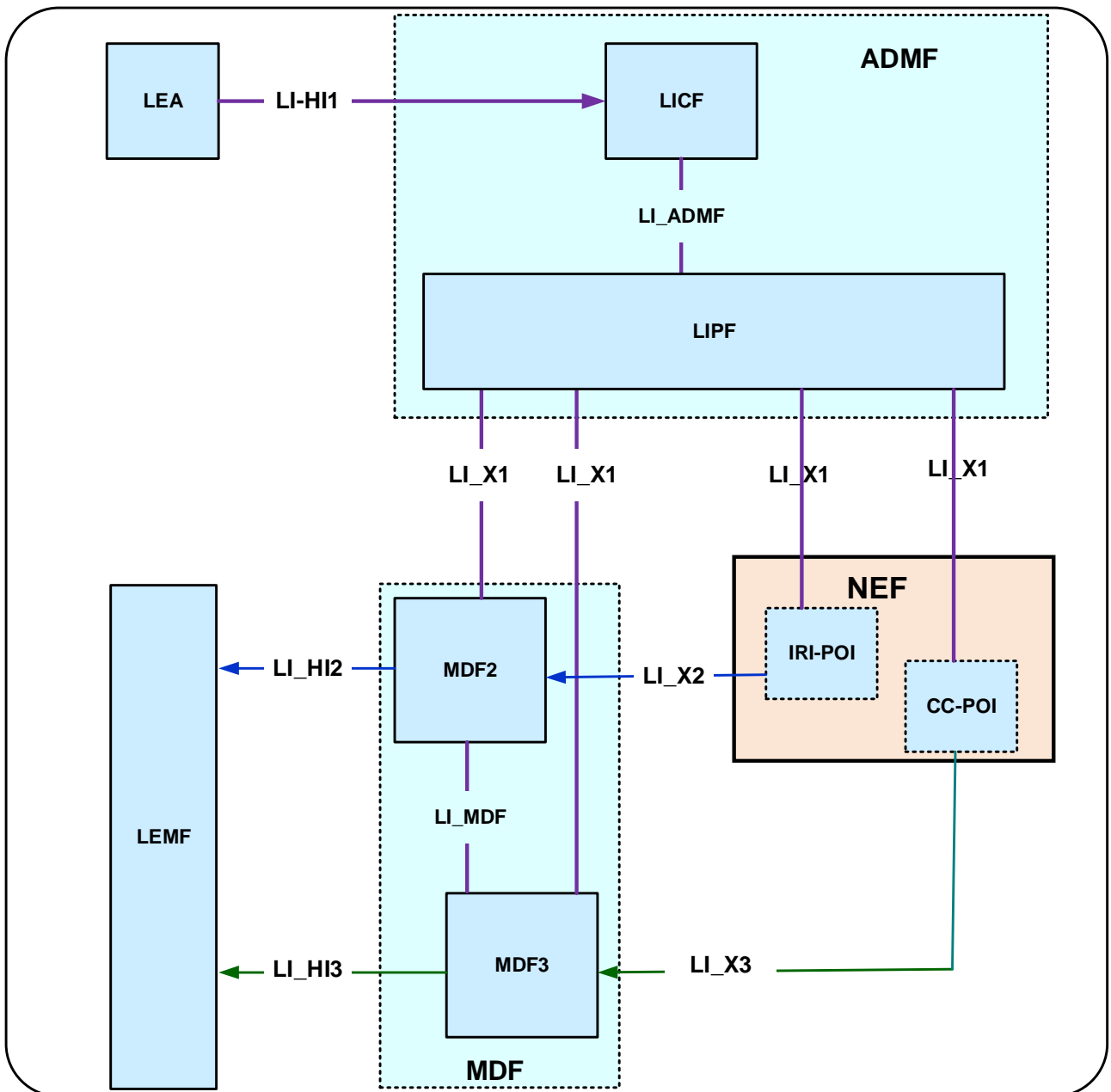

Figure 7.9-1: LI architecture for NIDD using NEF showing LI at NEF

### 7.9.2.2 Target Identities

The LIPF present in the ADMF provisions the intercept information associated with the following target identities to the IRI-POI present in the NEF:

- SUPI.
- GPSI.

The interception performed on the above two identities are mutually independent, even though, an xIRI may contain the information about the other identities when available.

### 7.9.2.3 IRI events

NEF handles xIRIs including the following records for NIDD using NEF in both roaming and non-roaming situations:

- PDU session establishment.

- PDU session modification.
- PDU session release.
- Start of interception with established PDU session.
- Unsuccessful procedure.

The PDU session establishment xIRI is generated when the IRI-POI present in the NEF detects that a PDU session for NIDD using NEF has been established for the target UE. The NEF plays the role of anchor point for that PDU session.

The PDU session modification xIRI is generated when the IRI-POI present in the NEF detects that a PDU session for NIDD using NEF is modified for the target UE.

The PDU session release xIRI is generated when the IRI-POI present in the NEF detects that a PDU session for NIDD using NEF is released for the target UE.

The start of interception with an established PDU session xIRI is generated when the IRI-POI present in the NEF detects that interception is activated on the target UE that has an already established PDU session for NIDD using NEF in the 5GS. When a target UE has multiple PDU sessions, this xIRI shall be sent for each PDU session with a different value of correlation information.

When additional warrants are activated on a target UE, MDF2 shall be able to generate and deliver the start of interception with an established PDU session related IRI messages to the LEMF associated with the warrants without receiving the corresponding start of interception with an established PDU session xIRI.

The unsuccessful procedure xIRI is generated when the IRI-POI present in the NEF detects an unsuccessful procedure for PDU session establishment, modification or release.

NEF handles xCC for NIDD using NEF if CC is requested.

## 7.9.3 LI for device triggering

### 7.9.3.1 Background

Device triggering is the means by which an AF sends information to the UE via the NEF to trigger the UE to perform application specific actions that include initiating communication with the AF (see TS 23.502 [4] clause 4.13.2 and TS 29.522 [31] clause 4.4.3).

The device trigger request is authorized by NEF by submitting the GPSI of the UE to the UDM. After successful authorization, NEF forwards the Device trigger request with the SUPI of the UE to the corresponding SMS-SC to be delivered to that UE. The 5GS architecture for Device triggering is presented in figure 7.9-2.

The device trigger may be recalled or replaced by the AF if the UE is not reachable at the time the AF has delivered the device trigger to the UE.

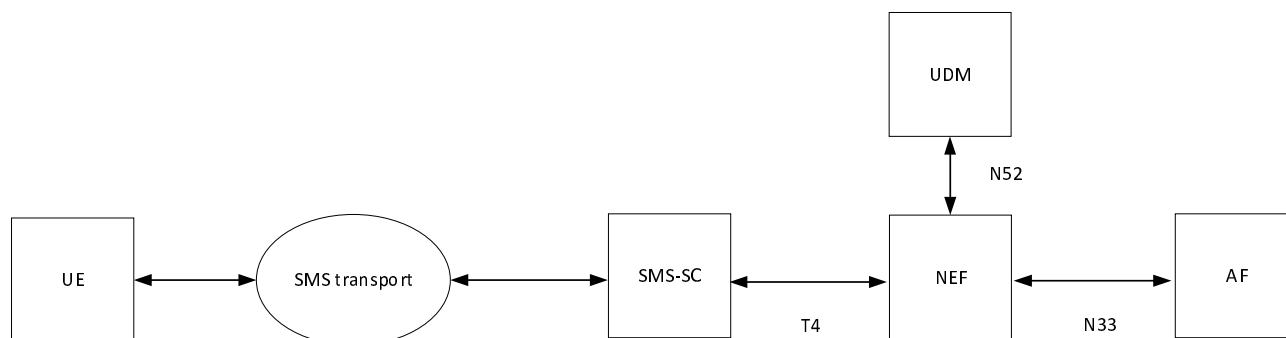

Figure 7.9-2: 5GS architecture for device triggering

### 7.9.3.2 Architecture

Figure 7.9-1 without the CC-POI in NEF provides the architecture for LI for device triggering.

### 7.9.3.3 Target identities

The LIPF present in the ADMF provisions the intercept information associated with the following target identities to the IRI-POI present in the NEF:

- SUPI.
- GPSI.

The interception performed on the above two identities are mutually independent, even though, an xIRI may contain the information about the other identities when available.

### 7.9.3.4 IRI events

The IRI-POI present in the NEF shall generate xIRI, when it detects the following specific events or information related to the device triggering service:

- Device trigger.
- Device trigger replacement.
- Device trigger cancellation.
- Device trigger report notification.

The device trigger xIRI is generated when the IRI-POI present in the NEF detects that a device trigger has been received from an AF and is delivered to the SMS-SC for the target UE.

The device trigger replacement xIRI is generated when the IRI-POI present in the NEF detects that a device trigger replacement has been received from an AF and delivered to the SMS-SC to replace previously submitted device trigger message which is not yet delivered to the target UE.

The device trigger cancellation xIRI is generated when the IRI-POI in the NEF detects that a device trigger cancellation has been received from an AF and delivered to the SMS-SC to recall previously submitted device trigger which is not yet delivered to the target UE.

The device trigger report notification xIRI is generated when the IRI-POI present in the NEF detects that a device trigger report is returned to the AF with a cause value indicating the trigger delivery outcome (e.g. succeeded, unknown or failed and the reason for the failure).

## 7.9.4 LI for MSISDN-less MO SMS

### 7.9.4.1 Background

An MSISDN-less MO SMS is sent by a UE without MSISDN as originator and received by a third party application as destination (i.e. AF) via SMS-SC and NEF as presented in figure 7.9-3. MSISDN-less means that the GPSI of the UE is not an MSISDN but an External Identifier which form is username@realm. MSISDN-less MO-SMS service allows MSISDN-less UE to send small data to an AF using SMS-MO. The SMS-MO received by the SMS-SC through MO submission procedure as defined in TS 23.040 [50], is directly forwarded to the NEF for further transfer to the recipient AF (see TS 23.502 [4] clause 4.13.7 and TS 29.522 [31] clause 4.4.10).

The NEF queries the UDM with the SUPI of the UE, obtains the corresponding GPSI of the UE sending the SMS, and forwards it to the AF including the GPSI (i.e. external identifier) of the originating UE.

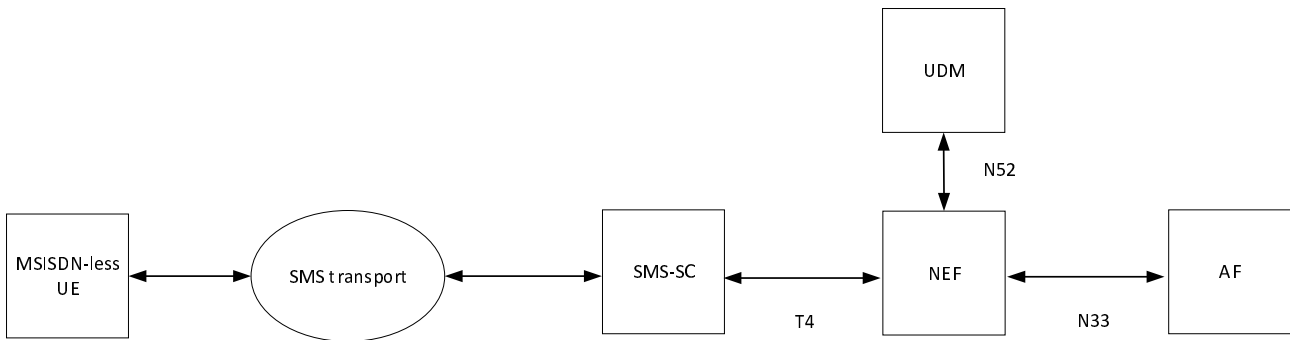

Figure 7.9-3: 5GS architecture for MSISDN-less MO SMS

7.9.4.2 Architecture

Figure 7.9-1 without the CC-POI in NEF provides the architecture for LI for MSISDN-less MO SMS.

7.9.4.3 Target identities

The LIPF present in the ADMF provisions the intercept information associated with the following target identities to the IRI-POI present in the NEF:

- SUPI.
- GPSI.

The interception performed on the above two identities are mutually independent, even though, an xIRI may contain the information about the other identities when available.

7.9.4.4 IRI events

The IRI-POI present in the NEF shall generate xIRI, when it detects the following specific events or information related to the MSISDN-less MO SMS:

- MSISDN-less MO SMS.

The MSISDN-less MO SMS xIRI is generated when the IRI-POI present in the NEF detects that a MSISDN-less MO SMS has been received from a target UE by the NEF and is delivered to the recipient AF.

7.9.5 LI for parameter provisioning

7.9.5.1 Background

Parameter provisioning is a capability exposed by NEF to AF (see TS 23.502 [4] clause 4.15.6 and TS 29.522 [31] clause 4.4.11). The AF can use this capability to tell the network when a device is expected to communicate. The core network can then use this information to create assistance information for the RAN. The RAN may then use the assistance information to minimize UE state transitions. The AF provides the Expected UE behaviour data specified in TS 29.503 [25] to NEF, and NEF updates the UE subscription data via UDM as described in figure 7.9-4. Each parameter within the Expected UE Behaviour shall have an associating validity time. The validity time indicates when the Expected UE Behaviour parameter expires. The validity time may be set to indicate that the particular Expected UE Behaviour parameter has no expiration time.

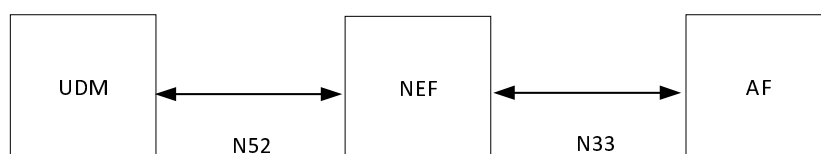

Figure 7.9-4: 5GS architecture for Parameter provisioning

### 7.9.5.2 Architecture

Figure 7.9-1 without the CC-POI in NEF provides the architecture for LI for parameter provisioning.

### 7.9.5.3 Target identities

The LIPF present in the ADMF provisions the intercept information associated with the following target identities to the IRI-POI present in the NEF:

- GPSI.

### 7.9.5.4 IRI events

The IRI-POI present in the NEF shall generate xIRI, when it detects the following specific events or information related to parameter provisioning:

- Expected UE behaviour update.

The expected UE behaviour update xIRI is generated when the IRI-POI present in the NEF detects that an AF sent a request to create, update, delete or get expected UE behaviour data related to the target UE and the NEF updates or gets these data from the UE subscription profile via UDM.

## 7.10 Non-IP data delivery (NIDD) in EPS

### 7.10.1 Background

#### 7.10.1.1 General

Functions for NIDD (Non-IP Data Delivery) may be used to handle Mobile Originated (MO) and Mobile Terminated (MT) communication for unstructured data (also referred to as Non-IP). Such delivery to the SCS/AS (Service Capability Server/ Application Server) is accomplished by one of the following two mechanisms as defined in TS 23.682 [33] clause 4.5.14:

- Delivery using SCEF.
- Delivery using a Point-to-Point (PtP) SGi tunnel.

If the subscription includes a "SCEF Identity for NIDD" corresponding with the APN information, then the MME selects that SCEF and uses the T6a interface to that SCEF, otherwise, the MME selects a SGW and PGW which handle this PDN connection. The PDN GW shares a SGi tunnel with the SCS/AS for the NIDD traffic exchange. If SCEF is used, the NIDD traffic is forwarded by SCEF to the SCS/AS. NIDD applies to non-roaming and roaming with home-routed roaming architecture.

#### 7.10.1.2 NIDD in non-roaming situation

##### 7.10.1.2.1 Delivery using SCEF

Figure 7.10-1 presents the architecture for delivery of NIDD using SCEF in non-roaming scenario. NIDD using SCEF requires a control plane PDN connection. The PDN connection is established between UE and SCEF via MME. The user traffic (i.e. NIDD traffic) is exchanged with DoNAS (Data over NAS) between UE and MME, then over T6a interface between MME and SCEF and finally over T8 interface between SCEF and SCS/AS.



**Figure 7.10-1: EPS Architecture for NIDD using SCEF**

7.10.1.2.2 Delivery using a PtP SGi tunnel

Figure 7.10-2 shows the architecture for delivery of NIDD using a PtP SGi tunnel in non-roaming scenario. The user traffic is exchanged with DoNAS between UE and MME, over S11 interface between MME and SGW, over S5 interface between SGW and PGW and finally over a PtP SGi tunnel between PGW and AF. The tunnel is typically a UDP/IP tunnel.

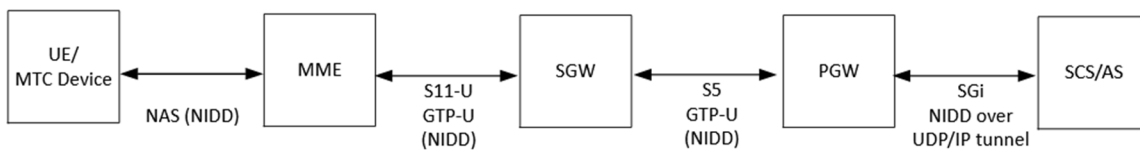
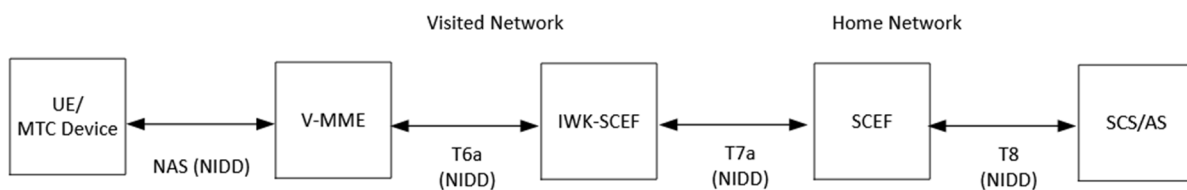

**Figure 7.10-2: EPS Architecture for NIDD using a PtP SGi tunnel**

7.10.1.3 NIDD in roaming situation

7.10.1.3.1 Delivery using SCEF

In roaming scenario, the PDN connection for NIDD using SCEF is established between UE and SCEF via V-MME and IWK-SCEF in the visited network and SCEF in the home network. The user traffic is exchanged with DoNAS between UE and V-MME, over T6a interface between V-MME and IWK-SCEF, over T7a interface between IWK-SCEF and SCEF and finally over T8 interface between SCEF and SCS/AS. Figure 7.10-3 shows the architecture for delivery of NIDD using SCEF in roaming situation.



**Figure 7.10-3: EPS Architecture for NIDD using SCEF in roaming situation**

7.10.1.3.2 Delivery using a PtP SGi tunnel

In roaming scenario, the PDN connection for NIDD using PtP SGi tunnel is established between UE and PGW via V-MME and V-SMF in the visited network and PGW in the home network. The user traffic is exchanged with DoNAS between UE and V-MME, over S11 interface between V-MME and V-SGW, over S8 interface between V-SGW and home PGW and finally over a PtP SGi tunnel between PGW and SCS/AS (figure 7.10-4).

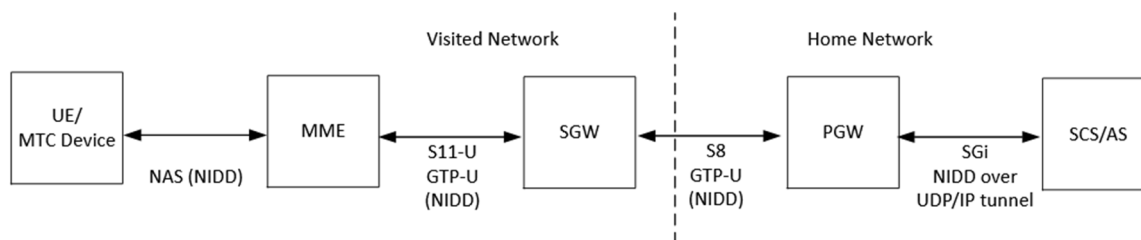

**Figure 7.10-4: EPS Architecture for NIDD using a PtP SGi tunnel in roaming situation**

## 7.10.2 LI for NIDD

### 7.10.2.1 LI for NIDD using SCEF

In non-roaming scenario, only SCEF will provide IRI-POI and CC-POI.

In roaming scenario, IWK-SCEF shall provide the IRI-POI and CC-POI functions for the visited network while SCEF in the home network provides IRI-POI and CC-POI.

NOTE: Only home-routed mode applies.

LI for NIDD using SCEF or IWK-SCEF is described in clause 7.10.2.2.

Packet header reporting and non-3GPP access are not applicable to NIDD.

### 7.10.2.2 LI for NIDD using a PtP SGi tunnel

In non-roaming scenario, the PGW provides an IRI-POI and a CC-POI. Although SGW provides an IRI POI and a CC-POI for IP and Ethernet-based PDN connections, PGW terminates the PtP SGi tunnel with the SCS/AS and has the same capabilities as SCEF for NIDD.

In roaming scenario, V-SGW and H-PGW shall provide the IRI-POI and CC-POI functions as shown in figure 6.3-2 which also concerns IRI-POI and CC-POI functions for IP and Ethernet-based PDN connections.

NOTE: Only home-routed mode applies for NIDD using a PtP SGi tunnel.

The LI architecture for NIDD using a PtP SGi tunnel is the same as presented in figure 6.3-2.

However, the user plane packets between UE and PGW flow through the MME and SGW as shown in figures 7.10-2 and 7.10-4.

The same xIRIs as specified in clause 6.3.3.3 for PDN connections of IP or Ethernet type and the same xCC are also considered for PDN connections for NIDD using a PtP SGi tunnel, considering unstructured payload format.

## 7.11 LI at SCEF

### 7.11.1 General

The present document specifies SCEF as POI for:

- NIDD.
- Device triggering.
- MSISDN-less MO SMS.
- Parameter provisioning.

## 7.11.2 LI for NIDD using SCEF

### 7.11.2.1 Architecture

The SCEF in the home network and the IWK-SCEF in the visited network shall provide both IRI-POI and CC-POI functions. Figure 7.11-1 gives a reference point representation of the LI architecture with SCEF as a CP NF and UP NF providing the IRI-POI and CC-POI functions for NIDD using SCEF. SCEF is the anchor point for PDN connection establishment and NIDD traffic.

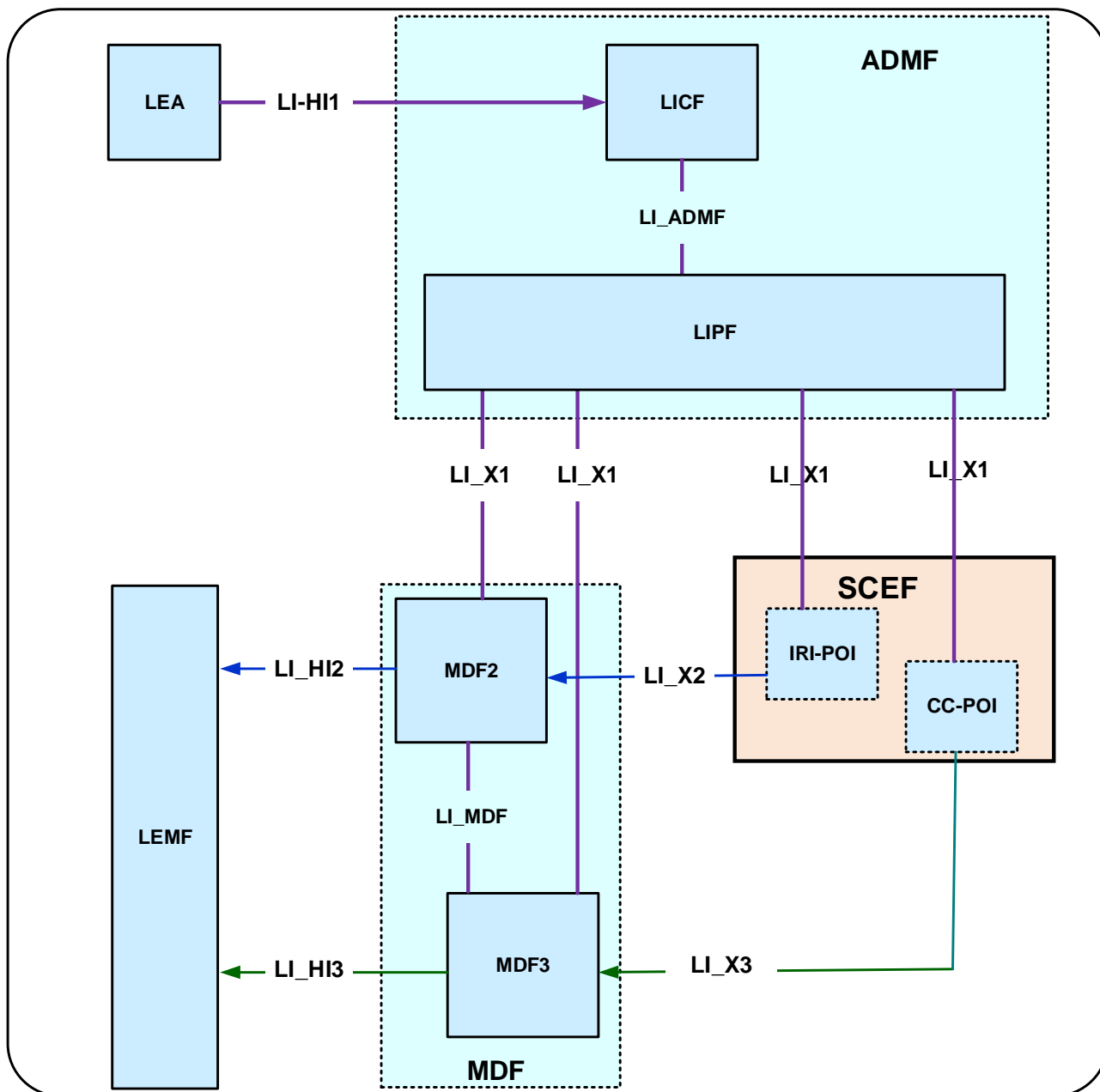

Figure 7.11-1: LI architecture for NIDD using SCEF showing LI at SCEF/IWK-SCEF

### 7.11.2.2 Target Identities

The LIPF present in the ADMF provisions the intercept information associated with the following target identities to the IRI-POI present in the SCEF:

- IMSI.



- MSISDN.
- External Identifier.

The interception performed on the above three identities are mutually independent, even though, an xIRI may contain the information about the other identities when available.

### 7.11.2.3 IRI events

The IRI-POI in the SCEF/IWK-SCEF shall generate xIRI when it detects the following specific events or information in both roaming and non-roaming situations:

- PDN connection establishment.
- PDN connection update.
- PDN connection release.
- Start of interception with established PDN connection.
- Unsuccessful procedure.

The PDN connection establishment xIRI is generated when the IRI-POI present in the SCEF/IWK-SCEF detects that a PDN connection for NIDD using SCEF has been established for the target UE. The SCEF plays the role of anchor point for that PDN connection.

The PDN connection update xIRI is generated when the IRI-POI present in the SCEF/IWK-SCEF detects that a PDN connection for NIDD using SCEF is modified for the target UE.

The PDN connection release xIRI is generated when the IRI-POI present in the SCEF/IWK-SCEF detects that a PDN connection for NIDD using SCEF is released for the target UE.

The start of interception with an established PDN connection xIRI is generated when the IRI-POI present in a SCEF/IWK-SCEF detects that interception is activated on the target UE that has an already established PDN connection for NIDD using SCEF in the EPS. When a target UE has multiple PDN connections, this xIRI shall be sent for each PDN connection with a different value of correlation information.

When additional warrants are activated on a target UE, MDF2 shall be able to generate and deliver the start of interception with an established PDN connection related IRI messages to the LEMF associated with the warrants without receiving the corresponding start of interception with an established PDN connection xIRI.

The unsuccessful procedure xIRI is generated when the IRI-POI present in the SCEF/IWK-SCEF detects an unsuccessful procedure for PDN connection establishment, update, release or data delivery, data reception.

SCEF/IWK-SCEF generates xCC for NIDD using SCEF if CC is requested.

## 7.11.3 LI for device triggering

### 7.11.3.1 Background

Device triggering is the means by which an SCS/AS sends information to the UE via the SCEF to trigger the UE to perform application specific actions that include initiating communication with the SCS/AS (see TS 23.682 [33] clause 5.2 and TS 29.122 [32] clause 4.4.6).

The device trigger request is authorized by SCEF by submitting the MSISDN or External Identifier of the UE to the HSS. After successful authorization, SCEF forwards the Device trigger request with the IMSI of the UE to the corresponding SMS-SC to be delivered to that UE. The EPS architecture for NIDD is presented in figure 7.11-2.

The device trigger may be recalled or replaced by the SCS/AS if the UE is not reachable at the time the SCS/AS has delivered the device trigger to the UE.

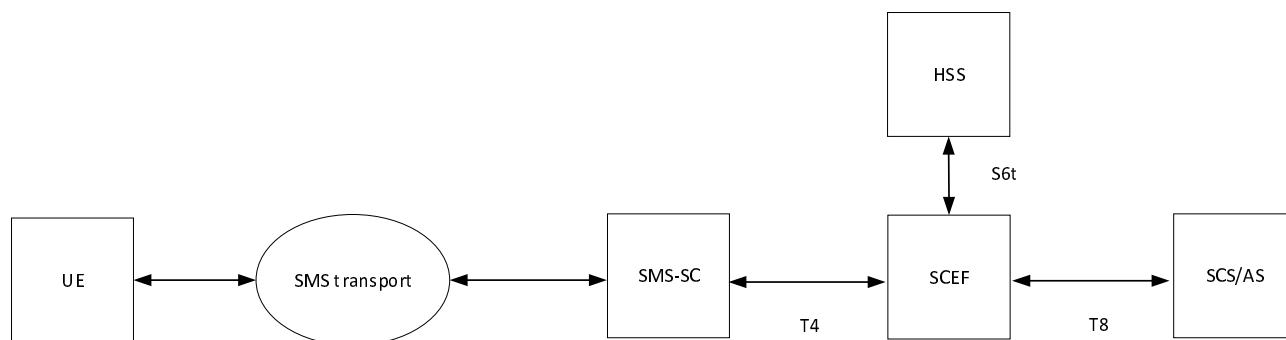

**Figure 7.11-2: EPS architecture for device triggering**

### 7.11.3.2 Architecture

The figure 7.11-1 without the CC-POI in SCEF provides the architecture for LI for device triggering.

### 7.11.3.3 Target identities

The LIPF present in the ADMF provisions the intercept information associated with the following target identities to the IRI-POI present in the SCEF:

- IMSI.
- MSISDN.
- External Identifier.

The interception performed on the above three identities are mutually independent, even though, an xIRI may contain the information about the other identities when available.

### 7.11.3.4 IRI events

The IRI-POI present in the SCEF shall generate xIRI, when it detects the following specific events or information related to the device triggering service:

- Device trigger.
- Device trigger replacement.
- Device trigger cancellation.
- Device trigger report notification.

The device trigger xIRI is generated when the IRI-POI present in the SCEF detects that a device trigger has been received from an SCS/AS and is delivered to the SMS-SC for the target UE.

The device trigger replacement xIRI is generated when the IRI-POI present in the SCEF detects that a device trigger replacement has been received from an SCS/AS and delivered to the SMS-SC to replace previously submitted device trigger message which is not yet delivered to the target UE.

The device trigger cancellation xIRI is generated when the IRI-POI in the SCEF detects that a device trigger cancellation has been received from an SCS/AS and delivered to the SMS-SC to recall previously submitted device trigger which is not yet delivered to the target UE.

The device trigger report notification xIRI is generated when the IRI-POI present in the SCEF detects that a device trigger report is returned to the SCS/AS with a cause value indicating the trigger delivery outcome (e.g. succeeded, unknown or failed and the reason for the failure).

## 7.11.4 LI for MSISDN-less MO SMS

### 7.11.4.1 Background

An MSISDN-less MO SMS is sent by a UE without MSISDN as originator and received by a third party application as destination (i.e. SCS/AS) via SMS-SC and SCEF. MSISDN-less means that the UE has a subscription without MSISDN but an External Identifier which form is username@realm. MSISDN-less MO-SMS service allows MSISDN-less UE to send small data to an SCS/AS using SMS-MO. The SMS-MO received by the SMS-SC through MO submission procedure as defined in TS 23.040 [50], is directly forwarded to the SCEF for further transfer to the recipient SCS/AS (see TS 23.682 [33] clause 5.15).

The SCEF queries the HSS with the IMSI of the UE, obtains the corresponding External Identifier of the UE sending the SMS, and forwards the SMS to the SCS/AS including the External Identifier of the originating UE.

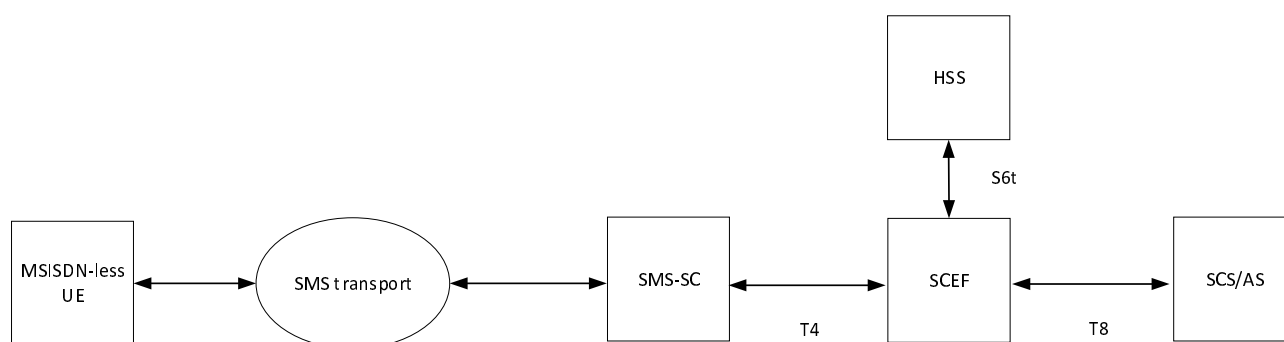

**Figure 7.11-3: EPS architecture for MSISDN-less MO SMS**

### 7.11.4.2 Architecture

Figure 7.11-1 without the CC-POI in SCEF provides the architecture for LI for MSISDN-less MO SMS.

### 7.11.4.3 Target identities

The LIPF present in the ADMF provisions the intercept information associated with the following target identities to the IRI-POI present in the SCEF:

- IMSI.
- External Identifier

The interception performed on the above two identities are mutually independent, even though, an xIRI may contain the information about the other identities when available.

### 7.11.4.4 IRI events

The IRI-POI present in the SCEF shall generate xIRI, when it detects the following specific events or information related to the MSISDN-less MO SMS:

- MSISDN-less MO SMS.

The MSISDN-less MO SMS xIRI is generated when the IRI-POI present in the SCEF detects that a MSISDN-less MO SMS has been received from a target UE by the SCEF and is delivered to the recipient SCS/AS.

## 7.11.5 LI for parameter provisioning

### 7.11.5.1 Background

Parameter provisioning is a capability exposed by SCEF to SCS/AS (see TS 23.682 [33] clause 5.10). The SCS/AS can use this capability to tell the network when a device is expected to communicate. The core network can then use this

information to create assistance information for the RAN. The RAN may then use the assistance information to minimize UE state transitions. The SCS/AS provides the communication pattern parameters to SCEF, and SCEF updates the UE subscription data via HSS. The parameters shall have a validity time. The validity time indicates when the communication pattern parameters expire. The validity time may be set to indicate that the communication pattern parameters have no expiration time.

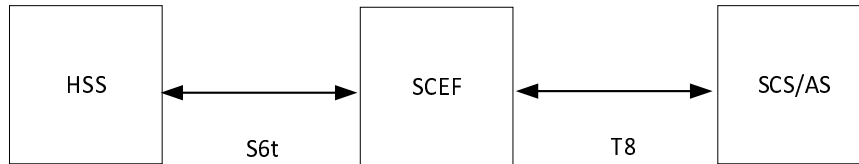

**Figure 7.11-4: EPS architecture for Parameter Provisioning**

### 7.11.5.2 Architecture

Figure 7.11-1 without the CC-POI in SCEF provides the architecture for LI for parameter provisioning.

### 7.11.5.3 Target identities

The LIPF present in the ADMF provisions the intercept information associated with the following target identities to the IRI-POI present in the SCEF:

- MSISDN.
- External Identifier.

### 7.11.5.4 IRI events

The IRI-POI present in the SCEF shall generate xIRI, when it detects the following specific events or information related to Parameter provisioning:

- Communication pattern update.

The communication pattern update xIRI is generated when the IRI-POI present in the SCEF detects that an SCS/AS sent a request to create, update, delete or get communication pattern data related to the target UE and the SCEF updates or gets these data from the UE subscription profile via HSS.

## 7.12 Data

### 7.12.1 General

This clause provides additional details on LI architecture, requirements and functionality for data services.

### 7.12.2 Packet header information reporting

#### 7.12.2.1 General

A warrant that does not require the interception of communication contents, may require IRI messages that have to be derived from the user plane packets. One report type that requires such a capability is the packet header information report.

#### 7.12.2.2 Report types

Depending on the requirements of the warrant, packet header information reporting may be done either in per-packet form, as one or more Packet Data Header Reports (PDHR), or in summary form, as one or more Packet Data Header Summary Reports (PDSR).

### 7.12.2.3 Implementation approaches

To support the generation of related xIRI (i.e. that requires access to the user plane packets), the present document supports two implementation approaches:

- In approach 1, xIRI (that includes the correlation number and the target identity) is generated by the IRI-POI in the UP Entity. The IRI-POI generates the xIRI from the user plane packets and sends it to the MDF2. The MDF2 generates the IRI messages and sends them to the LEMF.
- In approach 2, xCC is generated by the CC-POI in the UP Entity as if the warrant involves the interception of communication contents. To enable this, the CC-POI is presumed to be present and provisioned in the UP Entity even when the warrant does not require the interception of communication contents. The CC-POI generates the xCC and sends it to the MDF3. The MDF3 (based on the provisioned intercept information) does not generate and deliver the CC to the LEMF. Instead, the MDF3 forwards the xCC to the MDF2 over LI\_MDF interface. The MDF2 then generates the IRI messages from xCC and delivers those IRI messages to the LEMF.

In 5GS and CUPS EPS, the POI in the UP Entity requires a trigger to enable it to detect the user plane packets. The corresponding Triggering Function (IRI-TF or CC-TF) resides in the CP Entity that has the IRI-POI for the generation of other xIRI. The trigger sent by the IRI-TF or CC-TF to the corresponding POI includes the following:

- User plane packet detection rules.
- Target identity.
- Correlation information.
- MDF2 (in approach 1) or MDF3 (in approach 2) address.

## 7.13 RCS

### 7.13.1 Background

Rich Communication Suite (RCS) is the platform that enables the delivery of communication experiences beyond voice and SMS, providing consumers with a number of services related to:

- Capability discovery for enhanced contacts information.
- Standalone messaging:
  - Pager mode.
  - Large message mode.
- Chat:
  - 1-to-1.
  - Group chat.
- File URL transfer for enhanced messaging.
- Upload and download of files through HTTP Content Server.

RCS also covers additional services related to enriched calls. LI for these additional services is not defined in the present document.

As RCS requires the IMS to enable communication between RCS clients, the LI capabilities, requirements and architecture build on those defined for IMS in clause 7.4.

For additional details on LI for specific RCS services, see Annex D.

## 7.13.2 Architecture

### 7.13.2.1 Overview

The capabilities defined in this clause and the following subclauses apply to the LI for RCS. The LI architecture and functionality for RCS builds on the LI capabilities defined for IMS (see clause 7.4). When LI for RCS is required, the LI functions in IMS are provisioned as described in clause 7.4.

The network functions involved in providing the interception of RCS events are determined based on the deployment option, the network configuration, LI service scope and the RCS communication type. In general, the LI functions involved in the interception of RCS events are located either in the IMS core or in RCS specific network functions.

Additional topology options for RCS are described in clause 7.13.2.2.

The present document refers to any server that provides support, services or functions for RCS as an RCS Server. In general, RCS Servers are IMS Application Servers. The HTTP Content Server supports file upload, URI generation, and file download to allow for the transfer of files over RCS.

The following sub-clauses contain general stage 2 details for LI for RCS.

The RCS Servers shall have LI capabilities to generate xIRI records and xCC when RCS events related to the target UE are handled. The HTTP Content Server shall have LI capabilities to generate xIRI records and xCC when the target UE uploads or downloads a file and when any user downloads a file previously uploaded by a target. If an IRI-TF or CC-TF is required, the relevant RCS Server shall have the CC-TF. The figure 7.13.2-1 gives a reference point representation of the LI architecture for RCS interception.

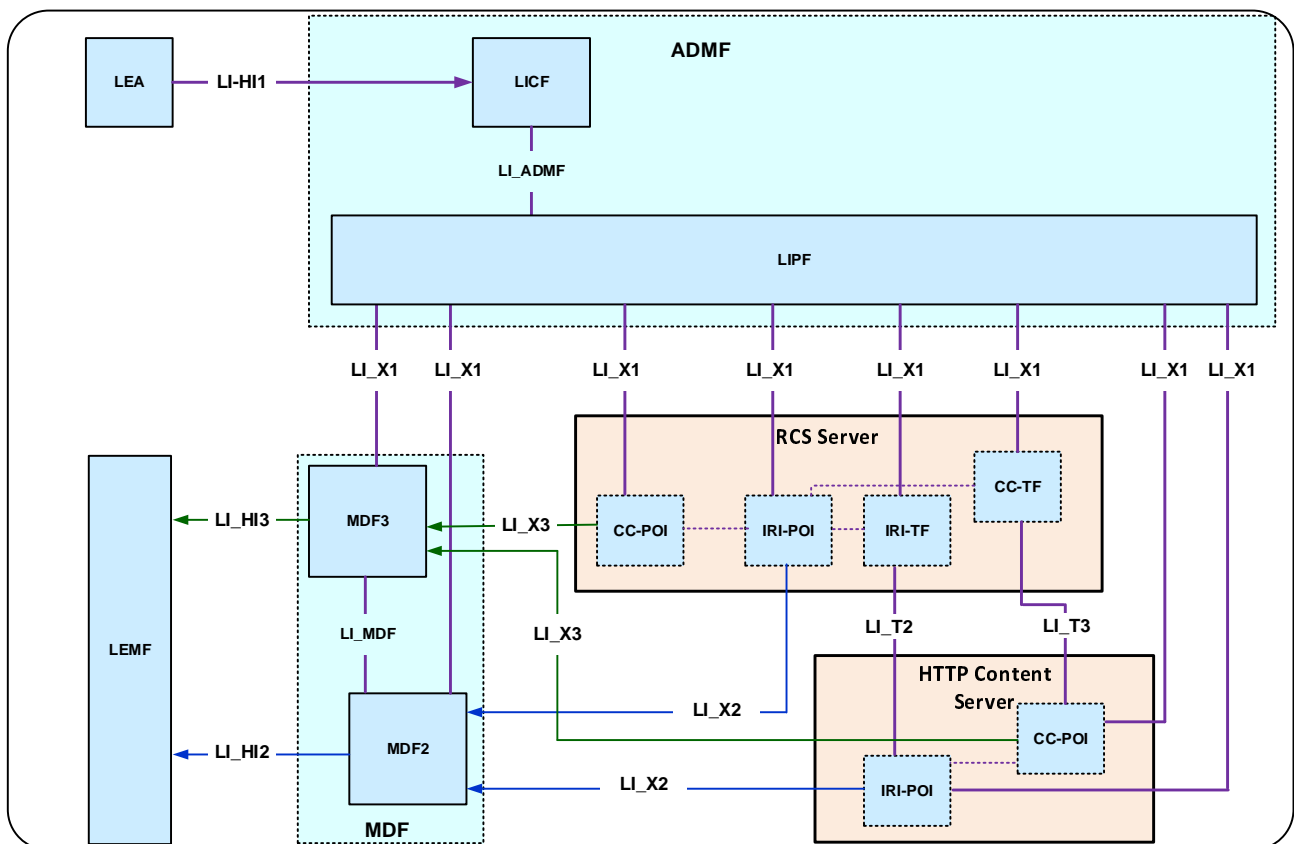

Figure 7.13.2-1: LI architecture for RCS services

The LICF present in the ADMF receives the warrant from an LEA, derives the intercept information from the warrant and provides it to the LIPF.

The LIPF present in the ADMF provisions the IRI-POI present in each RCS Server, the IRI-TF in the relevant RCS Servers, the MDF2 and the MDF3 over the LI\_X1 interfaces.

If the authentication method used to authenticate at the HTTP Content Server uses a permanent identifier, the LIPF present in the ADMF also provisions the IRI-POI in the HTTP Content Server.

To enable the interception of the target's message contents (e.g. when the warrant requires the interception of communication contents), the CC-POI in each RCS Server and the CC-TF present in the relevant RCS Servers are also provisioned with the intercept data.

If the authentication method used to authenticate at the HTTP Content Server uses a permanent identifier and the interception of the target's communication contents is required, the LIPF present in the ADMF also provisions the CC-POI in the HTTP Content Server.

NOTE 1: The IRI-POI, CC-POI, IRI-TF and CC-TF represented in figure 7.13.2-1 are logical functions and require correlation information be shared between them; they may be handled by the same process within the NF.

NOTE 2: The details on which RCS Servers require IRI-POIs, CC-POIs, and IRI-TFs or CC-TFs is dependent on implementation.

The IRI-POI present in the relevant RCS Server detects RCS registration and deregistration; session establishment, modification, and deletion; and message related events, generates and delivers the related xIRI to the MDF2 over LI\_X2. The MDF2 delivers the IRI messages to the LEMF over LI\_HI2.

When the IRI-TF present in the RCS Server detects a URI for file transfer, the IRI-TF present in the RCS Server sends a trigger to the IRI-POI in the HTTP Content Server over the LI\_T2 interface.

The IRI-POI present in the HTTP Content Server detects file uploads or downloads, generates and delivers the related xIRI to the MDF2 over LI\_X2. The MDF2 delivers the IRI messages to the LEMF over LI\_HI2.

When interception of communication contents is required, the CC-POI present in the relevant RCS Server generates the xCC from RCS messages and delivers the xCC (that includes the correlation number and the target identity) to the MDF3. The MDF3 delivers the CC to the LEMF over LI\_HI3.

When interception of communication contents is required, the CC-TF present in the RCS Servers sends a trigger to the CC-POI present in the HTTP Content Server over the LI\_T3 interface.

The trigger sent from the IRI-TF to the IRI-POI or the CC-TF to the CC-POI includes the following information:

- File detection rules.
- Target identity.
- Correlation information.
- MDF3 address.

The CC-POI present in the HTTP Content Server generates the xCC from the uploaded file and delivers the xCC (that includes the correlation number and the target identity) to the MDF3. The MDF3 delivers the CC to the LEMF over LI\_HI3.

## 7.13.2.2 Deployment options

### 7.13.2.2.1 Implementations without a third party registration to the RCS Server

As a deployment option, the S-CSCF may not perform a third party registration with the RCS Server. In this case, in addition to the architecture information in clause 7.13.2.1, the IRI-POI present in the IMS Signalling Function detects RCS registration and deregistration, generates and delivers the related xIRI to the MDF2 over LI\_X2.

NOTE: The method used within the IRI-POI present in the IMS Signalling Function to determine that the third party registration to the RCS Server is deployed is outside the scope of the present document.

### 7.13.2.2.2 Implementations that have a Localisation Function

As a deployment option, the terminating CSP may utilize a Localisation Function which retrieves objects from the originating HTTP Content Server and makes the same available to the terminating user.

If the CSP implements a Localisation Function, in addition to the architecture information in clause 7.13.2.1, the following requirements apply.

The LI architecture for the Localisation Function is the same as the LI architecture for the HTTP Content Server depicted in figure 7.13.2-1. In other words, the Localisation Function also has:

- An IRI-POI with:
  - An LI\_T2 interface to the IRI-TF in the RCS Server.
  - An LI\_X1 interface to the LIPF.
  - An LI\_X2 interface to the MDF2.
- A CC-POI with:
  - An LI\_T3 interface to the CC-TF in the RCS Server.
  - An LI\_X1 interface to the LIPF.
  - An LI\_X3 interface to the MDF3.

When the IRI-TF present in the RCS Server detects a URI for an incoming file transfer, the IRI-TF present in the RCS Server sends a trigger to the IRI-POI in the Localisation Function over the LI\_T2 interface. When interception of communication contents is required, the CC-TF present in the RCS Servers sends a trigger to the CC-POI present in the Localisation Function over the LI\_T3 interface. The trigger sent from the TF to the POI includes the following information:

- File detection rules.
- Target identity.
- Correlation information.
- MDF2 (for xIRI) or MDF3 (for xCC) address.

If the authentication method used to authenticate at the Localisation Function uses a permanent identifier (see clause 7.13.3), the LIPF present in the ADMF also provisions the IRI-POI in the Localisation Function.

In both cases, the IRI-POI present in the Localisation Function detects file uploads or downloads, generates and delivers the related xIRI to the MDF2 over LI\_X2. The MDF2 delivers the IRI messages to the LEMF over LI\_HI2.

If the authentication method used to authenticate at the file localisation sever uses a permanent identifier and the interception of the target's communication contents is required, the LIPF present in the ADMF also provisions the CC-POI in the Localisation Function.

If the interception of communications content is required, the CC-POI present in the Localisation Function generates the xCC from the uploaded file and delivers the xCC (that includes the correlation number and the target identity) to the MDF3. The MDF3 delivers the CC to the LEMF over LI\_HI3.

## 7.13.3 Target identities

The LIPF present in the ADMF provisions the intercept information associated with the following target identities to the IRI-POI, IRI-TF, CC-POI and CC-TF present in the RCS Server:

- IMPU.
- IMPI.
- IMEI.



In addition to the target identifiers listed above, the LIPF present in the ADMF provisions the intercept information associated with the following target identities to the IRI-POI and CC-POI present in the HTTP Content Server and the IRI-POI and CC-POI present in the Localisation Function:

- IMSI.
- SUPI.
- GPSI.
- Email Address.

The interception performed on identities above are mutually independent, even though an xIRI may contain the information about the other identities when available. The IRI-POI and CC-POI present in the RCS Servers and HTTP Content Servers shall also support interception of non-local identities in any of the IMPU formats (SIP URI, TEL URI as well as the E.164 number in a SIP URI or TEL URI), GPSI formats (E.164 number, external identifier) and email address.

## 7.13.4 IRI events

### 7.13.4.1 General RCS IRI events

As described in clause 7.13.2, the term RCS Server in the present document refers to any server performing support, services or functions for RCS. In most deployments there will be more than one RCS Server, and the events listed below shall be intercepted in the server responsible for performing the functions described by the event.

The IRI-POI present in the RCS Servers shall generate xIRI when it detects the following specific events or information:

- Registration.
- Deregistration.
- Capability discovery.
- RCS message.
- RCS message report.
- Session establishment.
- Session modification.
- Session release.
- Group chat establishment.
- Group chat modification.
- Group chat release.
- Start of interception with already registered UE.
- Start of interception with already established session.
- Unsuccessful procedure.

The IRI-POI present in the HTTP Content Server shall generate xIRI when it detects the following specific events or information:

- File upload.
- File download.
- Unsuccessful procedure.

The registration xIRI is generated when the IRI-POI present in an RCS Server detects that a target UE has been registered for RCS services.

The deregistration xIRI is generated when the IRI-POI present in an RCS Server detects that a target UE has been deregistered from RCS services.

The capability discovery xIRI is generated when the IRI-POI present in the RCS Server detects that a target UE has updated the target UE's RCS capabilities. This xIRI is also generated when a target UE gets information about the capabilities and state of another RCS user.

The RCS message xIRI is generated when the IRI-POI present in an RCS Server detects that a target UE sends or receives an RCS message.

The RCS message report xIRI is generated when the IRI-POI present in an RCS Server detects that a target UE sends or receives a response to an RCS message.

The session establishment xIRI is generated when the IRI-POI present in an RCS Server detects that an RCS session has been created for a target UE.

The session modification xIRI is generated when the IRI-POI present in an RCS Server detects that an RCS session has been modified for a target UE.

The session release xIRI is generated when the IRI-POI present in an RCS Server detects that an RCS session has been released for a target UE.

The group chat establishment xIRI is generated when the IRI-POI present in an RCS Server detects that the target UE has joined an RCS group chat session.

The group chat modification xIRI is generated when the IRI-POI present in an RCS Server detects that a group chat session the target UE is participating in is modified.

The group chat release xIRI is generated when the IRI-POI present in an RCS Server detects that the target UE leaves a group chat session.

The start of interception with already registered UE xIRI is generated when the IRI-POI present in an RCS Server detects that interception is activated on the target UE that is already registered for RCS services.

The start of interception with an established RCS session xIRI is generated when the IRI-POI present in an RCS Server detects that interception is activated on a target UE that has an already established RCS session. When a target UE has multiple RCS sessions, this xIRI shall be sent for each RCS session with a different value of correlation information.

When additional warrants are activated on a target UE, MDF2 shall be able to generate and deliver the start of interception with already registered UE and start of interception with already established RCS session related IRI messages to the LEMF associated with the warrants without receiving the corresponding xIRI.

The file upload xIRI shall be generated when the IRI-POI in the HTTP Content Server detects that a target UE has uploaded a file or when any UE has uploaded a file destined for the target UE.

The file download xIRI shall be generated when the IRI-POI in the HTTP Content Server detects that a target UE has downloaded a file or when any UE has downloaded a file previously uploaded by a target UE.

The unsuccessful procedure xIRI is generated when the IRI-POI present in an RCS Server or HTTP Content Server detects that a target UE initiated communication procedure (e.g. session establishment, RCS Message) is rejected or not accepted by the RCS Server before the proper NF handling of the procedure itself is involved. The unsuccessful procedure xIRI is also generated when the IRI-POI present in the RCS Server or HTTP Content Server detects that any request from the target UE is not accepted by the RCS Server or HTTP Content Server.

#### 7.13.4.2 RCS events for topologies without a third party registration to the RCS Server

The events specified in clause 7.13.4.1 apply with the following changes:

Rather than the IRI-POI present in the RCS Servers, the IRI-POI present in the IMS Signalling Function shall generate xIRI when it detects the following specific events or information:

- Registration.

- Deregistration.

The registration xIRI is generated when the IRI-POI present in the IMS Signalling Function detects that a target UE has been registered for RCS services.

The deregistration xIRI is generated when the IRI-POI present in the IMS Signalling Function detects that a target UE has been deregistered from RCS services.

### 7.13.4.3 RCS events for topologies utilising a Localisation Function

The events specified in clause 7.13.4.1 apply with the following changes:

In addition to the IRI-POI present in the HTTP Content Server (as described in clause 7.13.4.1), the IRI-POI present in the Localisation Function shall generate xIRI when it detects the following specific events or information:

- File upload.
- File download.
- Unsuccessful procedure.

The file upload xIRI shall be generated when the IRI-POI in Localisation Function detects that a target UE has uploaded a file or when any UE has uploaded a file destined for the target UE.

The file download xIRI shall be generated when the IRI-POI in the Localisation Function detects that a target UE has downloaded a file or when any UE has downloaded a file previously uploaded by a target UE.

The unsuccessful procedure xIRI is generated when the IRI-POI present in the Localisation Function detects that any request from the target UE is not accepted by the Localisation Function.

## 7.14 STIR/SHAKEN and RCD/eCNAM

### 7.14.1 General

Annex E provides detailed description of STIR SHAKEN and RCD/eCNAM procedures.

### 7.14.2 Architecture

The IMS Signaling Function that interacts with the AS for verification or the LMISF-IRI (inbound roaming with HR) or P-CSCF (inbound roaming with LBO) shall provide the IRI-POI functions for STIR/SHAKEN and RCD/eCNAM. In addition, at the originating side of the session, the IMS Signaling Function that interacts with the AS for signing shall provide the IRI-POI functions for STIR/SHAKEN and RCD.

Depending on the deployment, the IMS signaling function that interacts with the AS for signing is either the Telephony AS or the Egress IBCF (see figure E.2.1-1). Similarly, depending on the deployment, the IMS signaling function that interacts with the AS for verification is either the Telephony AS or the Ingress IBCF (see figure E.2.1-1).

Accordingly, the table 7.14.2-1 identifies the IRI-POIs for STIR/SHAKEN and RCD while table 7.14.2-2 identifies the IRI-POIs for eCNAM.

**Table 7.14.2-1: IMS Network Functions providing the IRI-POI functions for STIR/SHAKEN and RCD**

Target/session scenarios		Originating end		Terminating end	
		Option 1	Option 2	Option 1	Option 2
UE is the target	Non-roaming UE/outbound roaming UE	Telephony AS	Egress IBCF	Telephony AS	Ingress IBCF
	Inbound roaming UE (HR)	n/a	n/a	LMISF-IRI	LMISF-IRI
	Inbound roaming UE (LBO)	n/a	n/a	P-CSCF	P-CSCF
	Emergency session	Egress IBCF	Egress IBCF	n/a	n/a
From target non-local ID	Non-roaming UE/Outbound roaming UE	n/a	n/a	Telephony AS	Ingress IBCF
	Inbound roaming UE (HR)	n/a	n/a	LMISF-IRI	LMISF-IRI
	Inbound roaming UE (LBO)	n/a	n/a	P-CSCF	P-CSCF
To target non-local ID	Non-roaming UE/Outbound roaming UE	Telephony AS	Egress IBCF	n/a	n/a
	Inbound roaming UE (HR)	n/a	n/a	n/a	n/a
	Inbound roaming UE (LBO)	n/a	n/a	n/a	n/a

**Table 7.14.2-2: IMS Network Functions providing the IRI-POI functions for eCNAM**

Target/session scenarios		Originating end		Terminating end	
		Option 1	Option 2	Option 1	Option 2
UE is the target	Non-roaming UE	n/a	n/a	Telephony AS	Ingress IBCF
	Inbound roaming UE (HR)	n/a	n/a	LMISF-IRI	LMISF-IRI
	Inbound roaming UE (LBO)	n/a	n/a	P-CSCF	P-CSCF
	Emergency session	n/a	n/a	n/a	n/a
From target non-local ID	Non-roaming UE	n/a	n/a	Telephony AS	Ingress IBCF
	Inbound roaming UE (HR)	n/a	n/a	LMISF-IRI	LMISF-IRI
	Inbound roaming UE (LBO)	n/a	n/a	P-CSCF	P-CSCF
To target non-local ID	Non-roaming UE	n/a	n/a	n/a	n/a
	Inbound roaming UE (HR)	n/a	n/a	n/a	n/a
	Inbound roaming UE (LBO)	n/a	n/a	n/a	n/a

NOTE: In the tables option 1 and option 2 indicate the deployment options of IMS Signaling Function that interacts with the AS for signing or AS for verification. Such deployment options can be mutually independent in the originating CSP or the terminating CSP. For emergency sessions, Egress IBCF interacts with the AS for signing.

### 7.14.3 IRI events

The IRI-POI present in the IMS network functions listed in table 7.14.2-1 and 7.14.2-2 shall generate xIRI when it detects the following specific events or information:

- Signature generation.
- Signature validation.

The Signature generation xIRI is generated when the IRI-POI present in the Telephony AS for non-roaming UE or outbound roaming UE (HR) or in the egress IBCF detects that the Telephony AS or egress IBCF has sent a signing request (HTTP POST request) to the AS for signing and received a signing response (HTTP 200 OK) containing the Identity header. This interaction occurs when the Telephony AS or egress IBCF has received a SIP INVITE request or SIP MESSAGE request from a UE. The xIRI shall contain the identity token which also includes the signed RCD information if RCD is supported, and the initial caller number if changes occur on that number.

The Signature validation xIRI is generated when:

- The IRI-POI present in the Telephony AS or ingress IBCF has sent a verification request (HTTP POST request) containing the Identity token to the AS for verification and received a verification response (200 OK) containing the verification outcome (validation passed / validation failed / no validation). The xIRI shall contain the calling party identity, the identity token, the verification outcome, and the RCD or eCNAM related information if RCD or eCNAM is supported.

- The IRI-POI present in the P-CSCF for inbound roaming UE (LBO) or LMSIF-IRI for inbound roaming UE (HR) receives a SIP INVITE or a SIP MESSAGE request including appropriate SIP headers containing the verification outcome and RCS or eCNAM related information if RCS or eCNAM is supported.

These xIRIs should be correlated by MDF2 with the xIRIs related to IMS session establishment or SMS over IP delivery. The correlation identifier found in the STIR/SHAKEN xIRIs and IMS xIRIs should help the MDF2 performing the correlation procedure and generated IRIs with both sets of data for delivery to LEMF.

## 7.15 LI for services encrypted by CSP-provided keys

### 7.15.1 Background

#### 7.15.1.1 General

3GPP standards have defined frameworks for encrypting application layer traffic based on cryptographic keys derived from USIM (or equivalents such as eSIM). These frameworks can be characterized by a Key Server Function (KSF), located at the home CSP and having a connection to the AAA infrastructure (typically the AUSF). The KSF reuses the basic network layer authentication service (native 5G AKA or EAP-AKA') to obtain a derived anchor key. From this anchor key, the KSF can derive one or more service specific keys, which can be provided to various application functions. Such an application function provides, besides the application specific functionality, a Security Termination Function (STF) endpoint for the security with the UE. The KSF uses a 5G native identifier space for subscribers such as SUPI, whereas the STF could in principle use any identifier type to identify its users. Additionally, while the KSF is always located in HPLMN, the STF can be located either in HPLMN, in VPLMN, or even outside a PLMN, e.g. at an enterprise.

In 5G context, the principles laid out above are currently realized by the Authentication and Key Management for Applications (AKMA) based on 3GPP credentials in the 5G System as defined in TS 33.535 [47] and also by legacy frameworks such as the Generic Bootstrapping Architecture (GBA), TS 33.220 [48], which is currently undergoing specification for use in the 5GS.

**NOTE :** The terms KSF and STF above are defined for use in the present document, and will in general be realised by network functions specific to a given key management protocol or framework. See clause 7.15.3.1.1 for an example of how these terms are mapped to functions defined by the AKMA framework.

#### 7.15.1.2 LI requirements - overview

This clause specifies a common LI architecture for a general CSP-provided key management solution in support of encryption, implemented by generic KSF and STF functionality as defined in clause 7.15.1.1.

When encryption keys are provided by a CSP, lawful interception for a target's communication may be done in one of the two ways: (i) decrypt intercepted communication traffic before delivering IRIs and CCs to the LEA, or, (ii) provide to the LEA the decryption keys and other information necessary to enable the decryption of communication traffic. To fully enable decryption of communication traffic, LI functions are in general required both at the KSF and at the STF as illustrated by the following examples.

**EXAMPLE 1:** In most situations, after STF has obtained encryption key from KSF, the STF has all the necessary information to decrypt the communication traffic without the additional help of KSF. In this situation, an LI function within the STF can decrypt the target's communication and does not need to provide, explicit encryption-related xIRI. However, the STF can also have access to xIRI which is not related to encryption, but which is still application specific, and which also can be of relevance to include as part of IRI.

**EXAMPLE 2:** In some situations, STF may not know whether communication traffic is that of a target since it could use a user identifier space which is independent from the 5G identifiers used for LI provisioning. In this situation, the LI function in KSF will have to provide intercept triggers to the LI function in the STF in order to identify the target communication traffic. Moreover, even if decrypted xCC is provided by the STF, the KSF can still typically report xIRI relating to key management (e.g. request for keys from other STFs, expiry of keys etc) which are of relevance for LI. For a third example of applicability of LI at the KSF, refer to NOTE 3 below.

As mentioned, the physical/jurisdictional location of KSF and STF can differ depending on the scenario which can have bearing on LI requirements.

NOTE 1: When a warrant is served to a PLMN that has neither the STF nor the KSF, handling of LI aspects specifically related to the encrypted communication traffic of a target is outside the scope of the present document.

NOTE 2: For roaming situations, where LI providing unencrypted communication in the VPLMN is required, the STF would need to be located in the VPLMN and the STF would also need to use 5G native user identifiers which enable LI provisioning in the VPLMN (since LI can not rely on triggering from HPLMN in this case). However, such roaming scenarios are outside the scope of the present document.

NOTE 3: When a warrant is issued to a HPLMN that has the KSF, but not the STF, then the LI function in that KSF can still provide encryption related keys and related events to the LEMF. LI at the STF is however then outside the scope of the present document.

To summarize, with respect to the LI at KSF and STF, three specific type of xIRIs are identified:

1. xIRI from KSF consisting of key management information such as decryption keys and thereto related information.
2. xIRI from STF consisting of other encryption related parameters, referred to as auxiliary security parameters.
3. xIRI from STF which are application specific but not pertaining to encryption.

### 7.15.2 Architecture

Figure 7.15.2-1 shows the general LI architecture where an IRI-POI in the KSF provides the xIRIs that include key management related information such as the decryption keys to the MDF2 over the LI\_X2 interface. The STF can provide xIRI and xCC for the target's communication traffic, as described in more detail below. Figure 7.15.2-1 shows the case where STF is assumed to provide services based on 5G-native identifier, e.g. SUPI, enabling the STF to be provisioned over LI\_X1.

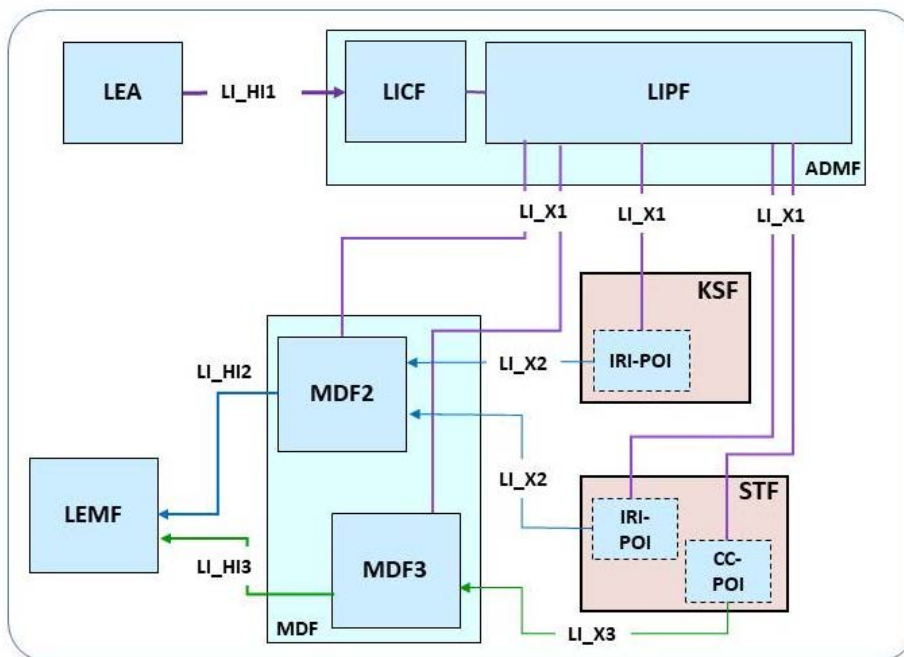

NOTE: If the STF is located outside the PLMN (not shown), the LI\_X2 from IRI-POI in KSF can be used to provide IRI with key management information such as decryption keys via MDF2.

**Figure 7.15.2-1: General architecture, STF using 5G native identifiers.**

If the STF instead provides services based on some other user identifier space, the STF POIs are assumed to be triggered by IRI-TF and CC-TF in the KSF, as shown in figure 7.15.2-2. The triggering is based on the KSF detecting requests from the STF for cryptographic keys associated with a target UE. When the key management service of the

KSF is based on target specific key identifiers (KID) known both at KSF and STF, such KID can serve as basis for mapping STF-identifiers to 5G-native identifiers at the KSF. The IRI-TF or CC-TF present in the KSF send the triggers to the IRI-POI or CC-POI present in the STF to indicate that the communication traffic is that of a target. The IRI-POI and CC-POI are then enabled for delivery of xIRI and the xCC with communication traffic of the target in a decrypted form as laid out above.

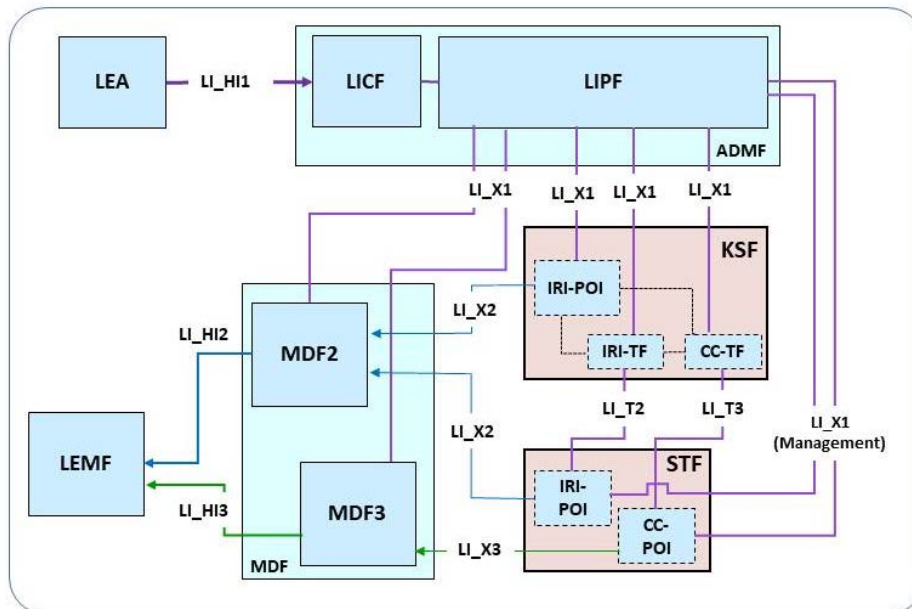

**Figure 7.15.2-2: General architecture, STF not relying on 5G native identifiers.**

The IRI-POI present in the KSF is provisioned by the LIPF over LI\_X1 and is responsible for providing key management related information in the form of xIRI. The key management related information can comprise information about requesting, creating, changing, or deleting encryption keys, and most importantly, can comprise decryption keys. Such decryption keys are generically denoted  $K_{LI}$  and may comprise one or more cryptographic keys.

The IRI-POI in the STF is responsible for providing xIRI with auxiliary security parameters necessary to decrypt xCC which has been encrypted using the keys provided by the KSF. In addition, application specific (not encryption related) xIRI for the target's communication traffic. In more detail, the auxiliary security parameters can typically include:

- Additional cryptographic keys.
- Selected protocols / cipher-suites / cryptographic algorithms for UE-STF traffic encryption.
- Parameters for key derivation (e.g. nonces).
- Other cryptographic state information (e.g. counters).

Similarly, the CC-POI in the STF is responsible for providing the xCC for the target's communication traffic in a decrypted form.

The remainder of the present clause provides details of IRI-intercept and, as applicable, CC-intercept of specific services encrypted by CSP-provided keys.

## 7.15.3 LI for specific services

### 7.15.3.1 LI for general AKMA-based service

#### 7.15.3.1.1 Background

In the specific case of AKMA (see TS 33.535 [47]), the KSF of the general architecture described above corresponds to the AAnF (AKMA Anchor Function). The STF corresponds to the AKMA Application Function (AF), identified by an application identifier AKMA AF\_ID. Key requests from external AFs are routed to AAnF via the NEF.

An AKMA Anchor Key is provided to the AAnF and is referred to as  $K_{AKMA}$ . The Anchor Key Identifier (A-KID) is used to identify the key  $K_{AKMA}$ . A-KID can by TS 33.535 [47] be assumed to be globally unique. The AAnF derives, from the anchor key, one or more application-dependent keys referred to as  $K_{AF}$  and provides the same to the AF.

The A-KID (and the associated  $K_{AKMA}$ ) of a specific UE can be modified by running 5G primary authentication. The A-KID can also become invalid at the AAnF due to specific AKMA Context Removal request from some duly authorized NF.

7.15.3.1.2 LI architecture

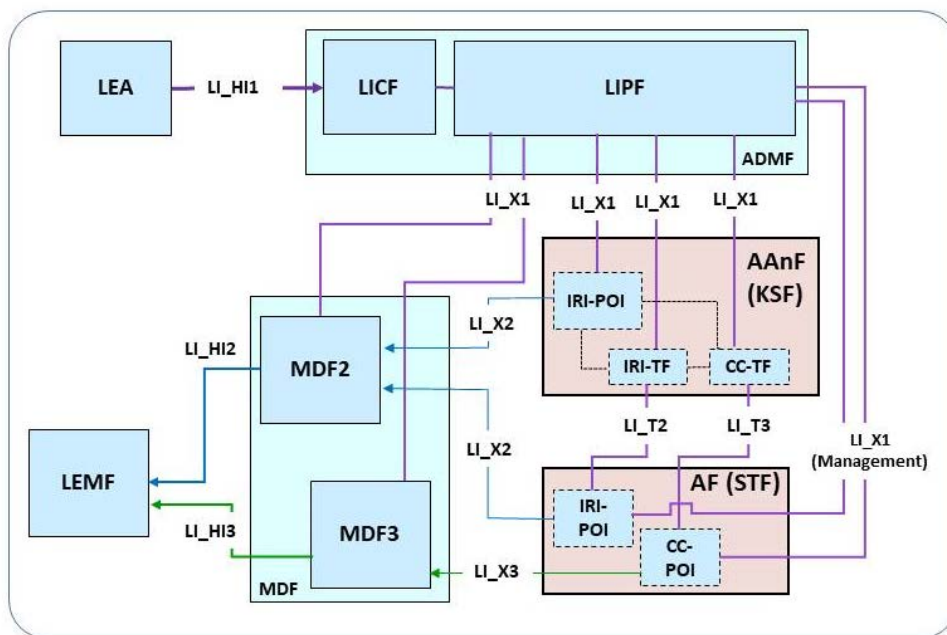

NOTE: If the AF is located outside the PLMN (not shown) the LI\_T2 and LI\_T3 interfaces are not used but LI\_X2 from IRI-POI in AAnF can still be used to provide IRI with key management information such as decryption keys via MDF2.

Figure 7.15.3.1-1: General AKMA LI Architecture

Table 7.15.3.1-1: Mapping functions between the general architecture and AKMA

Function in the general architecture of 7.15.2	Corresponding AKMA function	Reference
KSF	AAnF	TS 33.535 [47] clause 4.2.1
STF	AF	TS 33.535 [47] clause 4.2.2

The LIPF present in the ADMF provisions the IRI-POI present in the AAnF and the MDF2/MDF3 over LI\_X1 interfaces. The LIPF may interact with the SIRF (over LI\_SI) to find the correct instances of these functions. Depending on the warrant received from LEA, provisioning could be restricted to only specific services/AFs or could be general.

The LIPF also provisions IRI-TF and CC-TF present in the AAnF. The IRI-TF and CC-TF are capable of mapping AKMA key identifiers (A-KID) to/from SUPI. When a UE presents A-KID to the AAnF, via the AF, the IRI-TF and CC-TF present in the AAnF trigger the IRI-POI and CC-POI present in the AF respectively when LI is active on the SUPI associated with the A-KID.

The AAnF only provides xIRI comprising key management events (creation, modification, deletion, etc, of encryption keys), as well as cryptographic keys themselves ( $K_{AKMA}$  and/or  $K_{AF}$ ) and key identifiers (A-KID). The AF can provide both xIRI and xCC. The xIRI from the AF can comprise both auxiliary security parameters ( $Ua^*$  security protocol parameters, see below) and any other application specific information as set out in the general case described in clause 7.15.2.



Providing decrypted xCC depends on details of the security protocol used between the target UE and AF. This protocol is in AKMA referred to as the Ua\* security protocol. Below, the generic term "Ua\* security protocol parameters" is used to denote the complete set of auxiliary security parameters, besides the AKMA-related key material itself, necessary to decrypt the application traffic.

EXAMPLE: The Ua\* security protocol can be a profile of TLS version 1.2.

3GPP-defined Ua\* security protocols and protocol identifiers are defined in annex B of TS 33.535 [47] and currently cross-reference protocols defined in TS 33.222 [49].

**Table 7.15.3.1-2: Mapping xIRI between the general architecture and AKMA**

IRI-parameter in the general architecture of 7.15.2	Corresponding AKMA IRI	Reference
$K_{LI}$	$K_{AKMA}$ and/or $K_{AF}$	TS 33.535 [47] clause 6.1, 6.2
Key identifier, KID	A-KID	TS 33.535 [47] clause 4.4.2
auxiliary security parameters	Ua* security protocol parameters	TS 33.535 [47] clause 4.4.1

### 7.15.3.1.3 Target identities

#### 7.15.3.1.3.1 Provisioning

The LIPF present in the ADMF provisions the intercept information associated with the following target identity to the IRI-POI, IRI-TF and CC-TF present in the AAnF:

- SUPI.

#### 7.15.3.1.3.2 Triggering

To support LI in AKMA AFs not using SUPI identifiers, the triggering functions of the AAnF shall maintain a mapping from valid AKMA key identifiers (A-KID) to the SUPI.

An initial trigger for a new Task shall be issued to POIs of AFs matching the scope of the warrant when an A-KID for a target is first created. Since all such AFs might not be known in advance, this triggering can alternatively be performed dynamically, when a previously unknown AF requests key material related to a specific A-KID, from the AAnF.

Each time the A-KID of a target changes (due to primary authentication), the TF shall issue a new Task to the AF POI containing the new A-KID.

#### 7.15.3.1.4 IRI events

The IRI-POI present in the AAnF shall generate xIRI when it detects the following specific events or information related to an LI target:

- Anchor key register: AAnF receives AKMA-related key material from AUSF. This event can occur each time a target UE performs successful primary authentication to 5GC and then overwrites previous AKMA parameters stored at the AAnF.
- AKMA application key get: AAnF receives request for AKMA-related key material from a network-internal AF, or, from a network-external AF (via NEF).
- Start of intercept with established AKMA key material: AAnF detects that interception is activated on a target UE that has already established AKMA key material.
- AKMA context removal: An NF requests AAnF to remove AKMA-related key material.

The conditions under which the IRI-POI present in the AF generates xIRI is application-specific, but shall include at least the following events relating to xIRI with auxiliary security parameter:

- Application key refresh: AF performs local  $K_{AF}$  refresh with the target UE.

- Start of intercept with established AKMA application key: the AF detects that interception is activated on a target UE that already has an established  $K_{AF}$ .
- Auxiliary security parameter establishment: establishment or update of "Ua\* security protocol parameters" between the UE and the AF (e.g. nonces, selected security algorithms, etc.).
- Application key removal: the AF terminates the connection and does not make further use of  $K_{AF}$ .

### 7.15.3.1.5 Common IRI parameters

All xIRI shall include at least the following information:

- Target identity.
- Additional identities associated with the target as observed by the IRI-POI.

NOTE: This applies mainly for the AF.

- Time stamp.
- Correlation information.

### 7.15.3.1.6 Specific IRI parameters

Additionally, to the common IRI parameters, the following xIRI shall be provided by the IRI-POI of the AAnF for the specific IRI events.

The Anchor key register shall include:

- A-KID, Anchor key identity of the currently valid anchor key associated with the event, see TS 33.535 [47].
- The AKMA anchor key  $K_{AKMA}$  itself as defined in TS 33.535 [47], unless LI has been provisioned only for specific services or specific AFs.

The AKMA application key get shall include:

- Type: internal or external AF.
- AKMA AF\_ID (Application Function Identity), of the requesting application function. AF\_ID has format AF\_ID = FQDN of the AF || Ua\* security protocol identifier, as defined in TS 33.535 [47].
- A-KID.
- $K_{AF}$ , the Application Function specific key delivered to the requesting application function, as defined in TS 33.535 [47].
- $K_{AF}$  Expiration Time, the expiry time of  $K_{AF}$ , as defined in TS 33.535 [47].

NOTE 1: If the TLS-based Ua\* security protocols of annex B in TS 33.535 [47] is used between a target UE and STF, it could likely be the case that  $K_{AF}$  itself is insufficient as decryption key for xCC. Further key material only available as part of the "Ua\* security protocol parameters" element of xIRI obtained from the STF, see below, are then likely also needed.

- The Start of intercept with established AKMA key material shall include: A-KID (currently valid).

NOTE 2: While a new primary authentication overwrites old AKMA contexts ( $K_{AKMA}$  and A-KID), the expiry time of earlier application specific keys ( $K_{AF}$ ), derived from an old AKMA context (with an old A-KID) could still lie in the future when the Start of intercept with established AKMA key material occurs.

- The AKMA anchor key  $K_{AKMA}$  associated with currently valid A-KID, unless provisioning has been made service- or AF-specific.
- The set of all (AKMA AF\_ID,  $K_{AF}$ ,  $K_{AF}$  Expiration Time)-tuples associated with the target and satisfying all of:
  - Being available at AAnF,

- AF\_ID is within scope of previous LI-provisioning, and
- $K_{AF}$  Expiration Time has not yet been passed.

The AKMA context removal xIRI shall include:

- A-KID.
- NF identity, of the NF requesting the removal.

Additionally, to the common IRI parameters, the following xIRI shall be provided by the IRI-POI of an AF for the specific IRI events:

- Application key refresh:AKMA AF\_ID.
- A-KID.
- New  $K_{AF}$ .
- The set of "Ua\* security protocol parameters", if updated alongside  $K_{AF}$ .
- Start of intercept with established AKMA application key:The FQDN part of the AKMA AF\_ID.

NOTE 3: Since a given application function could have several parallel secured sessions with a target UE, the FQDN part of AF\_ID is reported separately, while details of each session, e.g. "Ua\* security protocol parameters", is reported in the information elements below.

- A-KID (currently valid).
- The set of all (A-KID,  $K_{AF}$ ,  $K_{AF}$  expiry, "Ua\* security protocol parameters")-tuples where A-KID is associated with the target and satisfying all of:
  - Being available in the AF and not having expired, and
  - The "Ua\* security protocol parameters" are associated with the specific A-KID /  $K_{AF}$ .

Auxiliary security parameter establishment:

- AKMA AF\_ID.
- A-KID associated with the "Ua\* security protocol parameters" being established or updated (i.e with  $K_{AF}$ ).
- $K_{AF}$  associated with the "Ua\* security protocol parameters" being established or updated.
- The actual set of "Ua\* security protocol parameters" associated with the event.

Application key removal:

- AKMA AF\_ID.
- A-KID.
- Cause (reason for removal, e.g. key expiration).

For both Start of intercept with established application key and Auxiliary security parameter establishment, if other cryptographic key material (besides  $K_{AF}$ ) is required to decrypt xCC, then it shall be ensured that all such key material is included as part of "Ua\* security protocol parameters".

**EXAMPLE:** One example when  $K_{AF}$  alone is insufficient is when the Ua\* security protocol deploys a separate "base secret" (e.g. from a stand-alone Diffie-Hellman key exchange), which is used by UE/AF when producing traffic encryption keys. In such case, also this base secret is needed for decryption.

### 7.15.3.1.7 Network topologies

The AAnF shall provide the IRI-POI, IRI-TF, and CC-TF functions, and the network-internal AF shall provide the IRI-POI function in the following network topology cases:

- Non-roaming case.

NOTE: Handling of AKMA-based services in the roaming case is currently not defined in TS 33.535 [47].

### 7.15.3.1.8 Provision of CC

Since AKMA is a non-service specific framework, interception of (decrypted) xCC at an AF for AKMA-secured services is not specified in further detail as part of clause 7.15.3.1. Non-service specific intercept of encrypted UP traffic could in some cases however be accomplished by combining the IRI-intercept (in particular, intercepted key material) of clauses 7.15.3.1.3 to 7.15.3.1.6 with the general solution for network layer xCC-intercept at the UPF as defined in clause 6.2.3.

---

## 8 LI security and deployment considerations

### 8.1 Introduction

The most sensitive information in the LI system is the target list. This is the list of all the subjects in the network currently under surveillance, whether active, suspended or in any other state. The security measures used by the carrier to prevent unauthorized access to this list is not subject to standardization, but the architectural choices made in the design of the LI system do impact the security of the target list directly.

Since completeness of the interception product is a legal requirement in most jurisdictions, the LI system shall ensure that no events that are lawfully authorized for interception are missed (or collected in error). To ensure that no events are missed there are two architectural alternatives.

### 8.2 Architectural alternatives

#### 8.2.1 Full target list at every POI node

A carrier may choose to deploy the full target list at all POIs, such that when a UE arrives in the network and commences registration, the POI is fully armed and in position to recognize if the target identifier is in the target list. The choice to push the full list to every node is the simplest, and arguably the riskiest, since the compromise of any node will leak the complete target list.

#### 8.2.2 Full target list only in LICF

A Communication Service Provider (CSP) may choose to selectively distribute specific target identifiers to specific POIs, rather than distributing the full target list to all POIs. This choice introduces a race condition. When the UE appears, the POI shall query the ADMF/LICF to find out if the user identifier is part of the target list. As the registration sequence progresses, the NF POI is waiting for a response from the ADMF/LICF. When the reply arrives, the POI can take action if the reply is positive. If the reply is negative, the POI's involvement ends.

If the reply is positive, depending on how long the POI-(ADMF/LICF)-POI round trip for the query/reply took, it is possible that some reportable events are missed. To mitigate this there are two further alternatives:

- 1) the carrier may choose to delay completion of the registration for all users for the time it takes the ADMF/LICF to answer, thus inducing a registration delay in all registrations, whether the user is a target or not, or
- 2) the carrier may choose to cache the reportable registration events while the POI-(ADMF/LICF)-POI query is running, and either report them if the answer is positive, or delete them if the answer is negative.

These are choices at the discretion of the CSP, but the trade-off cannot be avoided.

#### 8.2.3 Provisioning for registered users

When a new target is provisioned in the LI system, after the target is already registered in the CSP network, the CSP will be faced with the race condition consequences of the implementation choice made as described in clauses 8.2.1 and

8.2.2. The ADMF has a choice to either wholesale pre-arm every POI with the new target (and expect every POI to immediately start interception on the new target, as in clause 8.2.1), or, the ADMF can poll every serving UDM POI for all target UEs, and arm the associated POI (and start interception, as in clause 8.1.2) *only* if a target UE is discovered to be served by that particular NF. The second approach would take comparatively longer and would be expected to miss more of the on-going target interactions with the network than the first approach.

## 8.3 LI key management at ADMF

### 8.3.1 General

The ADMF is responsible for overall management of the LI system as defined in clause 5.3.2.4. The ADMF is responsible for creating and managing intermediate, client and root certificates used for both identity verification and establishing encrypted communications between LI components.

NOTE: The exact mechanism for installation of certificates in POIs, MDFs or other LI components (manual or automated) is outside the scope of the present document.

### 8.3.2 Key management

The ADMF shall implement an LI Certificate Authority (LI CA) which shall be used as the issuing CA for all LI components.

By default, the LI CA shall be a sub-CA of the CSP root CA, and may issue intermediate certificates.

The LI CA shall be responsible for creating, maintaining and revoking all identity verification and encryption certificates and root keys used by LI components communicating on LI\_X interfaces. It may also be responsible for issuing certificates and root keys for LI\_HI interfaces if these are not issued by the LEA/LEMF.

For virtualised implementations, the LICF shall support automated certificate enrolment for POIs, TFs and MDFs. For non-virtualised deployments, support for automatic certificate enrolment is optional.

The LICF shall maintain a list of all valid LI components for which the LI CA has generated certificates. The LICF shall instruct the LI CA to revoke any certificate belonging to LI components that are removed from the system (e.g. de-instantiated).

The LI CA shall provide a single certificate for each LI component. The LI component shall generate individual session keys for each LI\_X link.

## 8.4 Virtualised LI security

### 8.4.1 General

This clause provides requirements and deployment constraints relating to the virtualisation of LI in 3GPP networks.

### 8.4.2 NFVI and host requirements

NFVIs hosting LI functions defined in the present document, shall provide functionality for protecting sensitive functions as defined in ETSI GS NFV-SEC 012 [29] or equivalent specification.

### 8.4.3 Virtualised LI function implementation

LI functions as defined in the present document when virtualised shall include the use of one or more HMEEs as defined in ETSI GS NFV-SEC 012 [29] or equivalent specification, to protect as a minimum:

- LI target lists.
- Any LI dynamic selectors used internally within the NF to select target communications to be intercepted.
- Any cryptographic keys and LI\_X1/LI\_X2/LI\_X3 end points.

During runtime, NFs containing LI functions should not share NFVI hosts with any other NF, VNF or VNFC.

During runtime, NFs containing LI functions shall not share NFVI hosts with any other NF, VNF or VNFC which does not contain other authorised LI functions.

The NF runtime restriction requirements do not prevent hosts being used for different NFs over the lifetime of the NFVI, following termination of the previous VNF instances. However, both where hosts are newly allocated for LI use and when subsequently released, host memory and storage secure erase procedures as defined in ETSI GS NFV-SEC 012 [29] or equivalent specification shall be used.

## 8.4.4 Container based deployments

Where containers are used for implementing LI functionality, and when images corresponding to those containers are required to be stored at runtime in a system wide container cache, the LI Controller shall ensure that each time the container image is retrieved from the cache, the integrity of the image is validated. In addition, when the image is no longer required by a live running Network Function, the image is erased from the cache.

## 8.5 Points of Interception

CSPs use a wide range of 3GPP NFs to provide services to users. In order to intercept a service, POIs are associated with specific NFs, as depicted in Figure 8.5-1. The manner the POI obtains the required information from the NF depends on the service and can range from something as simple as a copy-and-forward mechanism, to sophisticated isolation and filtering. The POI may be embedded in the NF or external to the NF, connected to its interfaces. The choice of one, the other, or both approaches is service specific.

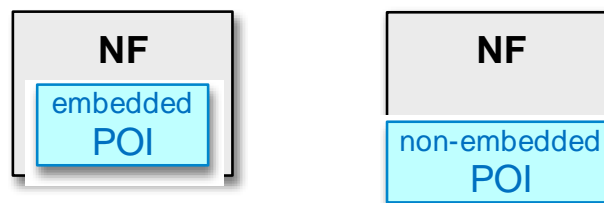

**Figure 8.5-1: Embedded vs. external POIs**

In figures 8.5-2 and 8.5-3 the POI will be depicted straddling the edge of the NF to simultaneously indicate both approaches.

Figure 8.5-2 shows the basic job of a POI: to obtain the state, or communicated user data, of the intercepted service. As the NF changes state, or as additional user data is generated or forwarded, in the course of providing the service, the appropriate interceptable events or real-time content are transferred into the POI.

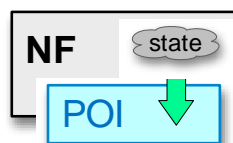

**Figure 8.5-2: POI state capture**

Although the POI has access to service state in the NF and information flows in and out of the NF, the NF shall not be able to access data in the POI, for obvious security reasons, as depicted in figure 8.5-3. If the POI is embedded, LI data leakage from the POI back into the non-secure area of the NF shall be prohibited. If the POI is not embedded, the implementation shall prohibit LI data leakage back into the NF.

The same requirements apply to TFs.

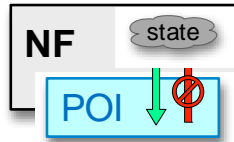

**Figure 8.5-3: POI state capture security**

Generally, embedded POIs have full access to the state machine of the service they intercept, while external POIs have to infer the state of the intercepted service from the events detected on the interfaces or externally applied traffic filtering criteria.

## 8.6 Deployment considerations

### 8.6.1 General

This clause provides deployment considerations for Lawful Interception.

### 8.6.2 CC-PAG

This clause introduces CC-PAG (CC-POI Aggregator) as an architectural extension that is located between the MDF3 and CC-POI. The CC-PAG performs the function of aggregating the xCC from different CC-POIs towards the MDF3 and is shown in Figure 8.6-1.

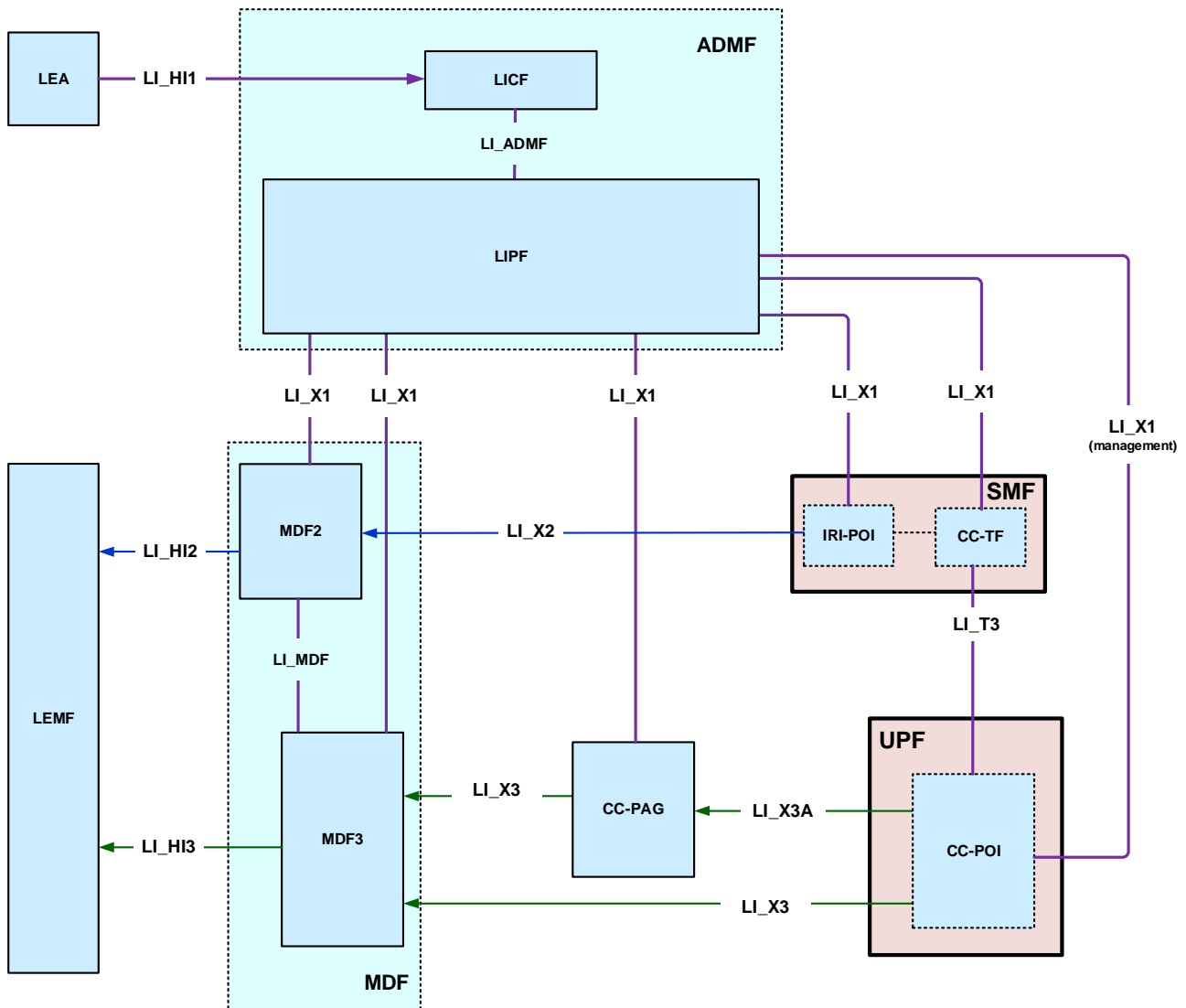

**Figure 8.6-1: LI architecture showing CC-PAG.**

NOTE: The IRI-POI and CC-TF represented in figure 8.6-1 are logical functions and require correlation information be shared between them; they may be handled by the same process within the SMF.

The CC-PAG is an optional LI function and may be deployed in networks that need aggregation of xCC from potentially large number of different CC-POIs towards the MDF3. The CC-PAG may be deployed closer to the UPFs, to reduce the impact of latencies, packet drops, and buffering on UPFs for lawful interception of highspeed user plane traffic. The system resources such as hardware interfaces, CPUs and memory for the CC-PAG node may be tuned to balance the forwarding/reception capabilities of CC-POI and MDF3.

As shown in figure 8.6-1, the CC-POI is triggered by the CC-TF to deliver the xCC (on a per flow basis) to the CC-PAG (via LI\_X3A interface) or to the MDF3 (via LI\_X3 interface as described in clause 6.2.3).

In the option where CC-PAG is involved, the LIPF configures the CC-PAG with the appropriate MDF3 address. The CC-PAG address is provided to the CC-POI using one of the two methods:

- 1) pre-provisioned (e.g. by LIPF over LI\_X0 interface) while instructed to use the pre-provisioned address over LI\_X1;
- 2) as a part of the CC intercept trigger by the CC-TF which in turn is provisioned by the LIPF over LI\_X1.

The CC-PAG aggregates the xCC received from different CC-POIs before forwarding the same to the MDF3. The xCC is not modified. The LI\_X3A interface is the same as LI\_X3 interface on the application level but may be used with other transport protocol options as described in ETSI TS 103 221-2 [16].



---

## Annex A (informative): 5G LI network topology views

### A.1 Non-roaming scenario

#### A.1.1 General

In a non-roaming scenario, the POIs present in the following NFs provide the LI functions:

- AMF.
- UDM.
- SMF.
- UPF.
- SMSF.
- NEF.

For the interception of PDU sessions, the EPC CUPS LI model is not extended to 5G where SMF and UPF are involved in delivering the xIRI and xCC associated with the PDU sessions.

NOTE: The above list of NFs that provide the POI functions may have to be expanded once a deployment scenario for such a case is defined in the normative part of the present document.

#### A.1.2 Service-based representation with point-to-point LI system

The overall network configuration for 5G in a non-roaming scenario with the LI aspects is shown in figure A.1-1 using the service-based representation (as shown in TS 23.501 [2]) with the use of point-to-point LI system.

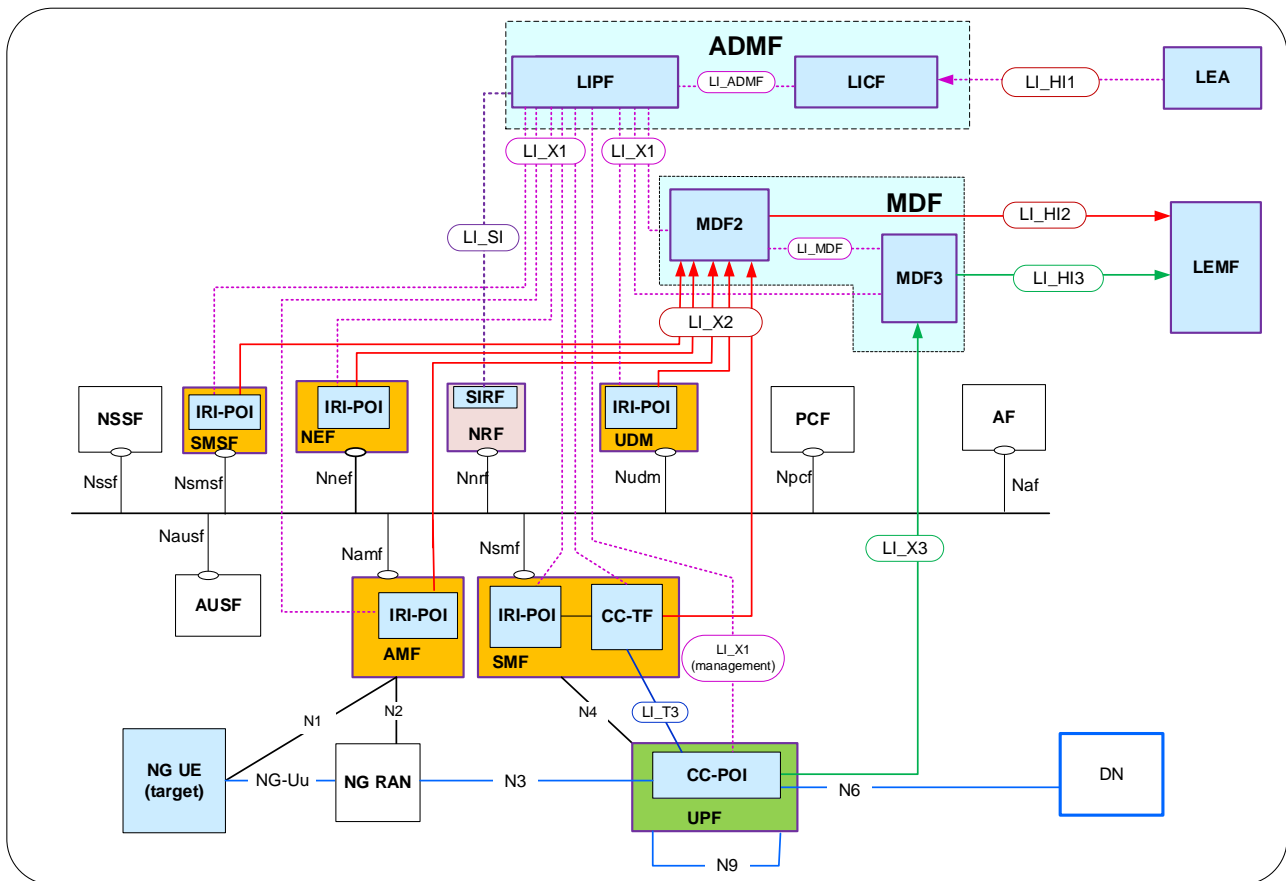

**Figure A.1-1: Network topology showing LI for 5G (service-based representation) with point-to-point LI system**

Figure A.1-1 shows the network topology of 5G system in a service-based representation; however, all the LI-related interfaces remain to be point-to-point.

The IRI-POIs present in the AMF, UDM SMF and SMSF deliver the xIRI to the MDF2 and CC-POI present in the UPF delivers the xCC to the MDF3. The MDF3 address to CC-POI present in UPF is provided by the CC-TF present in the SMF over LI\_T3 reference point.

The LIPF present in the ADMF provisions the IRI-POIs and the CC-TF present in the NFs with the intercept related data. The LI\_X1 interfaces between the LIPF and the UPF is to monitor the user plane data.

**NOTE:** The CC-POI present in the NEF is not shown in figure A.1-1 but will be present if intercept of those services is supported.

## A.2 Interworking with EPC/E-UTRAN

### A.2.1 General

In EPC/E-UTRAN, the NFs that provide the POI functions are:

- MME.
- SGW.
- PGW (optional).
- HSS.
- SCEF.

In a 5GS, the NFs that provide the POI functions are:

- AMF.
- SMF/UPF.
- UDM.
- SMSF.
- NEF.

In an interworking scenario between the EPC and the 5GS, the AMF in 5GS and MME in EPC provide the IRI-POI functions for the related attach/registration related aspects. When the network topology includes SMF + PGW-C and UPF + PGW-U as the interworking NFs, it is recommended that these provide the POI functions for the PDU sessions as the target communication traffic coming from either of the two interworking networks pass through these NFs. In that case, the interception at the SGW and UPF (if present between the NG-RAN and the UPF + PGW-U) is not required unless the condition specified in the NOTE in clause A.2.2 applies.

In a non-roaming scenario, the IRI-POI present in the HSS + UDM also provide the LI functions. The IRI-POI present in the SMSF provides the LI functions for the SMS-related IRI events.

## A.2.2 Topology view for a non-roaming scenario

The overall network configuration for interworking between EPC-EUTRAN and 5GS in non-roaming scenario with the LI aspects is shown in figure A.2-1.

The 5G core system is shown using the service-based representation (as shown in TS 23.501 [2]) with the use of point-to-point LI system.

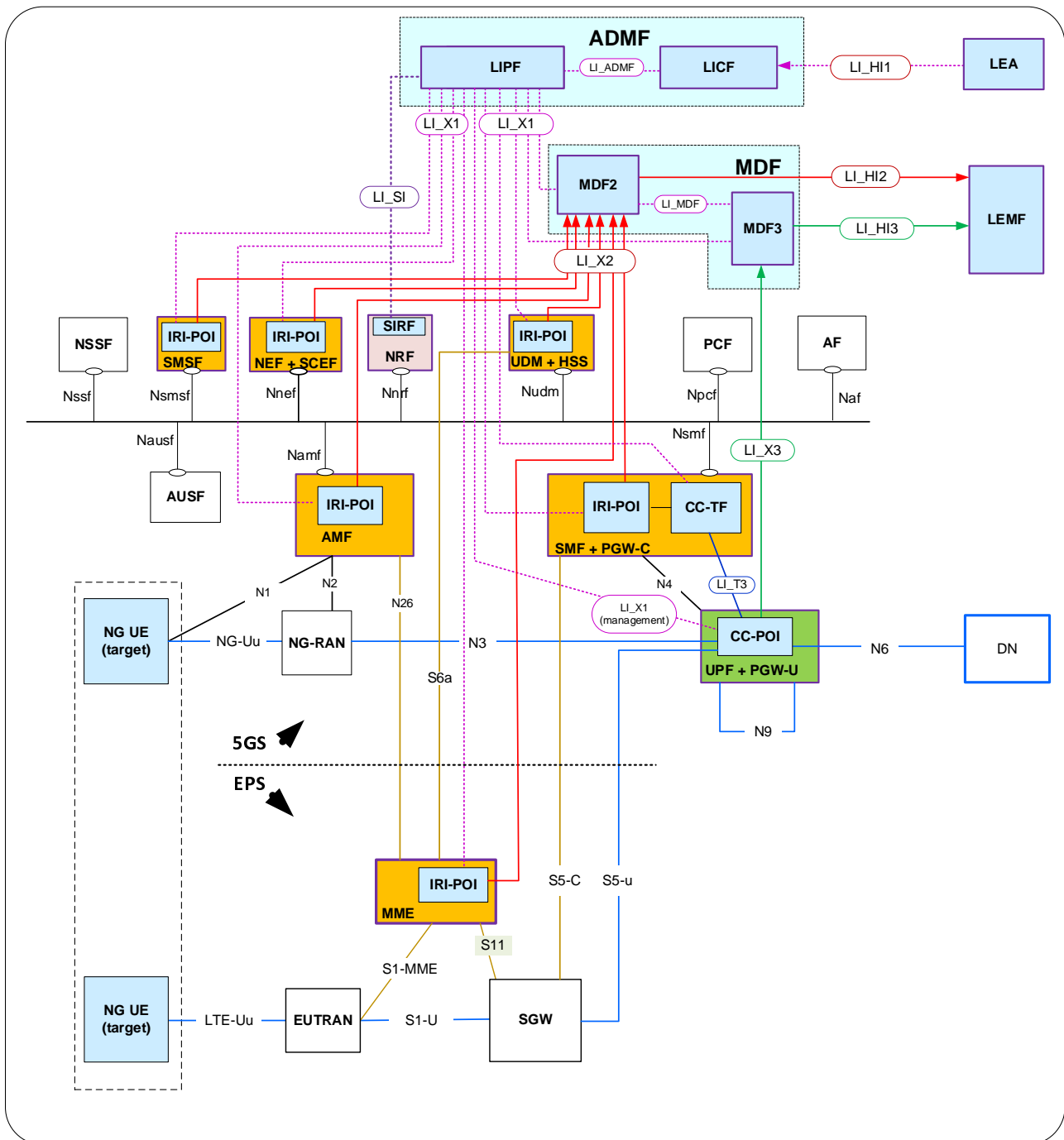

**Figure A.2-1: Network topology showing LI for interworking with EPC/E-UTRAN**

Figure A.2-1 shows the network topology of 5G system in a service-based representation, however, all the LI-related interfaces remain to be point-to-point.

The IRI-POIs present in the AMF, MME, UDM, SMSF and SMF + PGW-C deliver the xIRI to the MDF2 and CC-POI present in the UPF + PGW-U delivers the xCC to the MDF3. The MDF3 address to CC-POI present in UPF + PGW-U is provided by the CC-TF present in the SMF over LI\_T3 reference point.

The LIPF present in the ADMF provisions the IRI-POIs and the CC-TF present in the NFs with the intercept related data. The LI\_X1 interfaces between the LIPF and the UPF + PGW-U is to monitor the user plane data.

NOTE 1: TS 23.501 [2] notes that there can another UPF between the NG-RAN and PGW-U + UPF. In that case, the other UPF may also provide the CC-POI functions for any user plane packets that do not reach the PGW-U + UPF.

NOTE 2: The IRI-POIs and CC-POIs present in the NEF and the SCEF are shown as a combined function, but could be deployed as separate NEF and SCEF.

---

## A.3 Multiple DN connections in a PDU session

### A.3.1 General

According to TS 23.501 [2], a PDU session can involve multiple UPFs, but regardless of how many UPFs are involved in the session, the session only connects to a single DN through one or more DN connections (i.e. connections to the same DN).

When a PDU session involves multiple UPFs, the interception of user plane packets can be done in two ways:

- At one UPF (branching UPF) through which all the user plane packets pass through.
- At anchor UPFs.

When the second approach is chosen with branching UPF being one of the anchor UPFs, redundant delivery of CC should be avoided.

In a non-roaming scenario, the IRI-POI present in UDM also provide the LI functions.

### A.3.2 Topology view for a non-roaming scenario

The overall network configurations to illustrate the LI with multiple DN connections (to the same DN) in a PDU session is illustrated in figure A.3-1 and A.3-2.

The 5G core system is shown using the service-based representation (as shown in TS 23.501 [2]) with the use of point-to-point LI system.

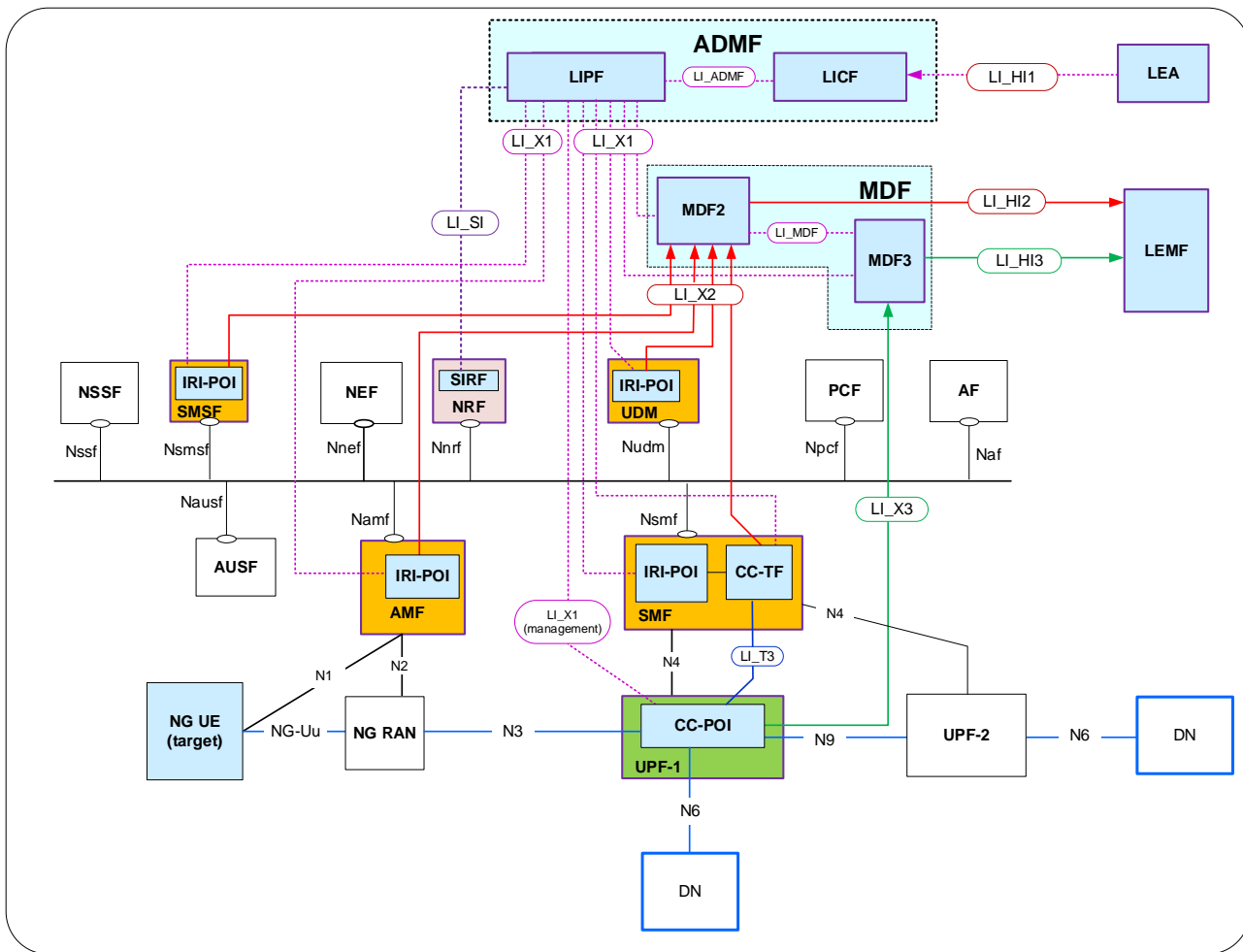

**Figure A.3-1: Network topology showing CC-POI at one UPF**

The IRI-POIs present in the AMF, MME, UDM, SMSF and SMF deliver the xIRI to the MDF2 and CC-POI present in the branching UPF (shown as UPF-1) on the common path to both DN connections delivers the xCC to the MDF3. The MDF3 address to CC-POI present in UPF-1 is provided by the CC-TF present in the SMF over LI\_T3 reference point. In this view, all user plane packets pass through UPF-1.

The LIPF present in the ADMF provisions the IRI-POIs and the CC-TF present in the NFs with the intercept related data. The LI\_X1 interfaces between the LIPF and the UPF is to monitor the user plane data.

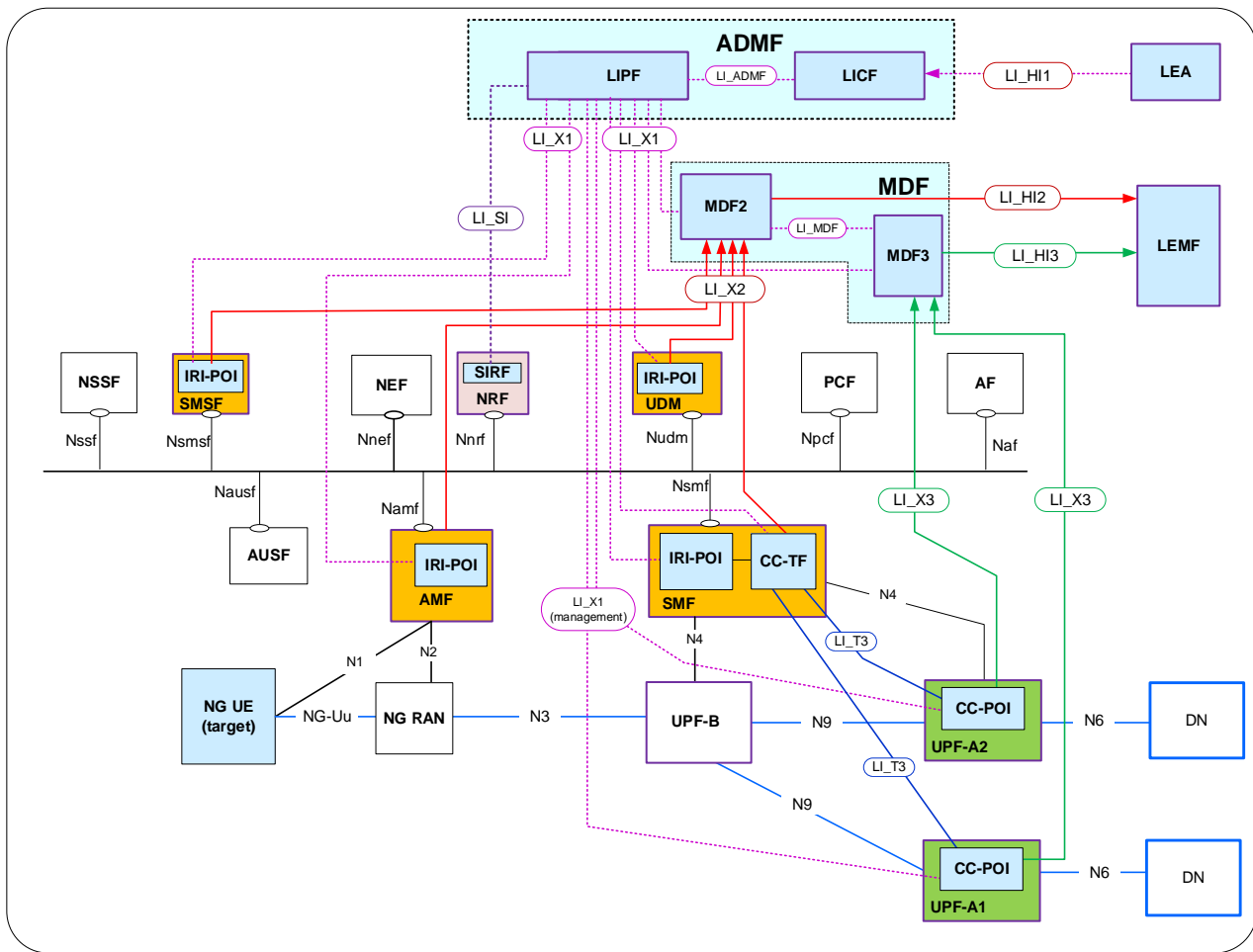

**Figure A.3-2: Network topology showing CC-POI at two UPFs**

The IRI-POIs present in the AMF, MME, UDM, SMSF and SMF deliver the xIRI to the MDF2. In this example, there is a branching UPF (UPF-B), an anchor UPF for the DN (UPF-A1) and another anchor UPF for the same DN (UPF-A2). The second approach (i.e. CC interception at the anchor UPFs) mentioned in A.3.1 is used to provide the CC interception. The UPF-A1 delivers the xCC generated from the user plane packets that flow from UE to the DN via UPF-A1 to the MDF3. The CC-POI present in the UPF-A2 delivers the xCC generated from the user plane packets that flow UE to the DN via UPF-A2 to the MDF3. The MDF3 address in the CC-POIs present in UPF-1 and UPF-2 are provided by the CC-TF present in the SMF over LI\_T3 reference point.

The LIPF present in the ADMF provisions the IRI-POIs and the CC-TF present in the NFs with the intercept related data. The LI\_X1 interfaces between the LIPF and the UPFs are to monitor the user plane data.

**NOTE:** In some cases, the branching UPF may be merged with one of the anchor UPFs. In this case care needs to be taken to avoid duplication of xCC e.g. by intercepting only on the external N6 interface of each anchor UPF.

## A.4 Non-3GPP access in a non-roaming scenario

### A.4.1 General

When the target UE is connected to the 5G core network via non-3GPP access, the POIs present in the following NFs of the PLMN where the N3A Entity resides provide the LI functions:

- AMF.
- SMF.

- UPF.
- SMSF.

When the PLMN that has the N3A Entity is the HPLMN, as illustrated in clause A.1, the IRI-POI present in the UDM also provide the LI functions.

When the PLMN that has N3A Entity is different from the PLMN that provides the 3GPP access to the target UE, two different AMFs are involved in handling the target UE's registration accepts (this is not illustrated in this clause). In this case, depending on the operator policy, the SMSF present in either of the two networks may perform the routing of SMS messages to and from the target UE.

The PLMN that provides the 3GPP access can be a VPLMN and PLMN where the N3A Entity resides can be the HPLMN. In this case, the AMF in the HPLMN provides the IRI-POI functions for non-3GPP access related registration events when the target UE is roaming. The SMSF present in the HPLMN may have to provide the IRI-POI functions for the SMS related messages routed via non-3GPP access network.

## A.4.2 Topology view

The overall network configuration for non-3GPP access in a non-roaming scenario with the LI aspects is shown in figures A.4-1, A.4-2 and A.4-3. In these views, the target UE is not connected to a 3GPP access network.

The 5G core system is shown in the following figures the service-based representation (as shown in TS 23.501 [2]) with the use of point-to-point LI system.



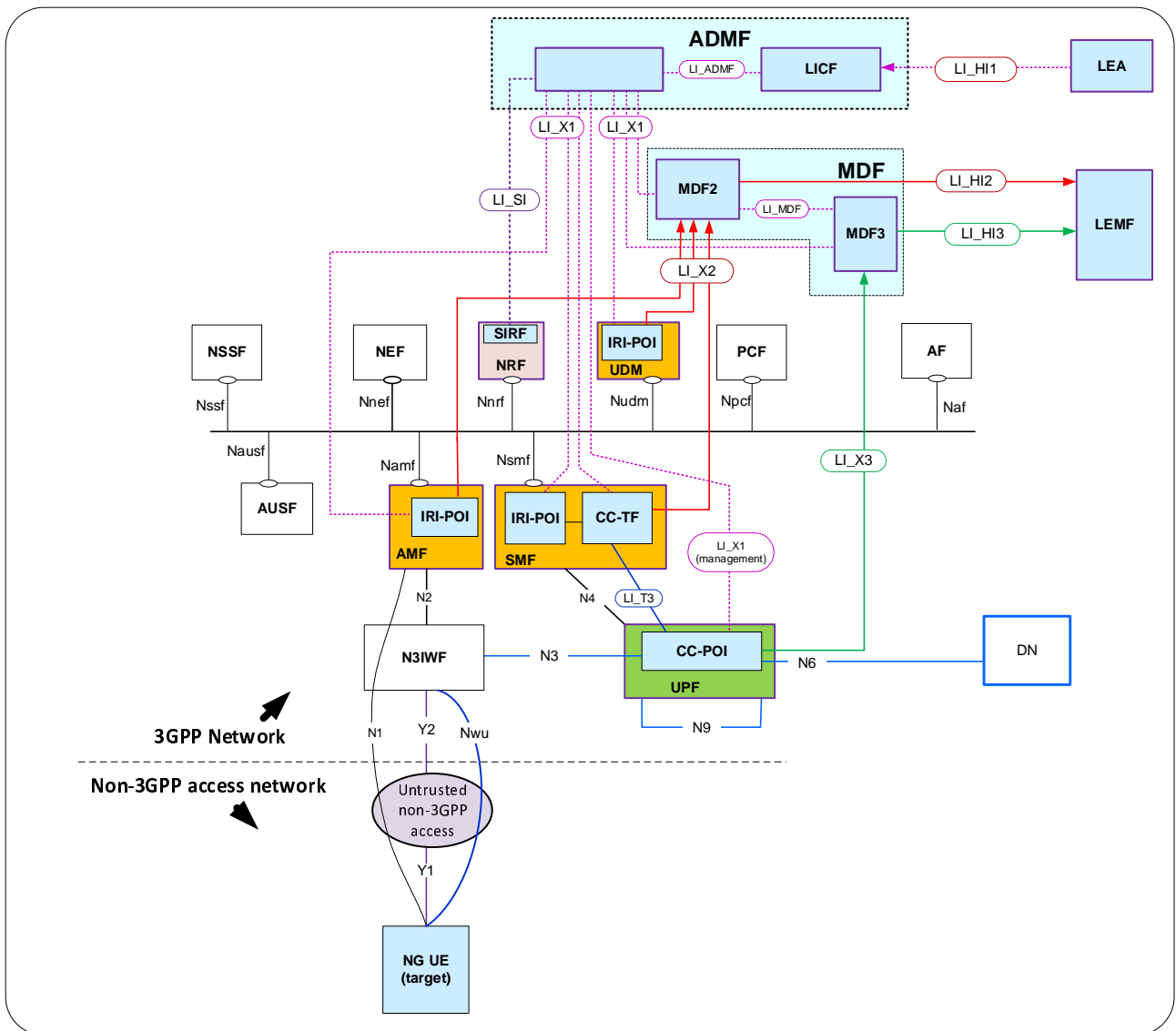

Figure A.4-1: Network topology showing LI for non-3GPP access to 5G via N3IWF

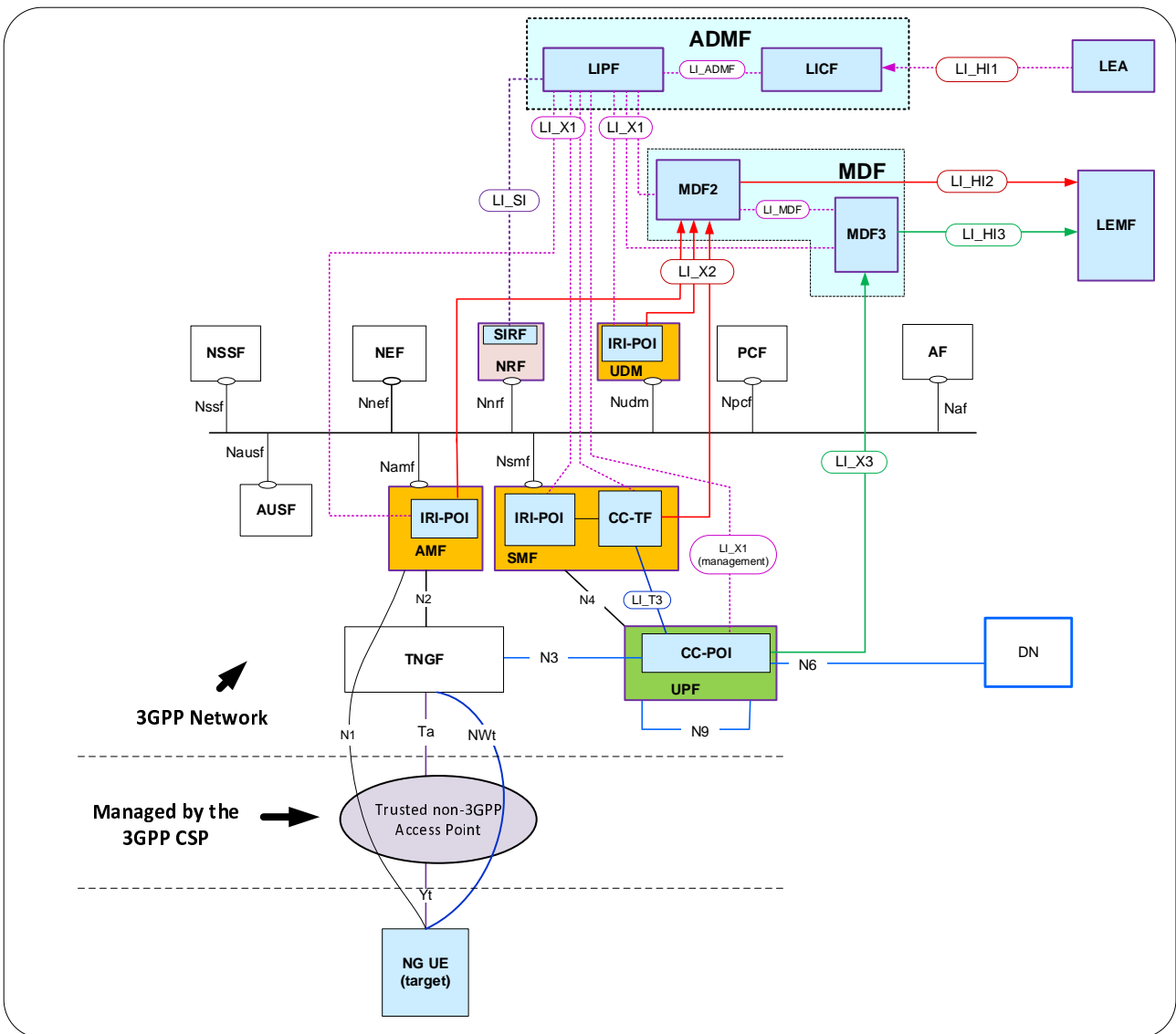
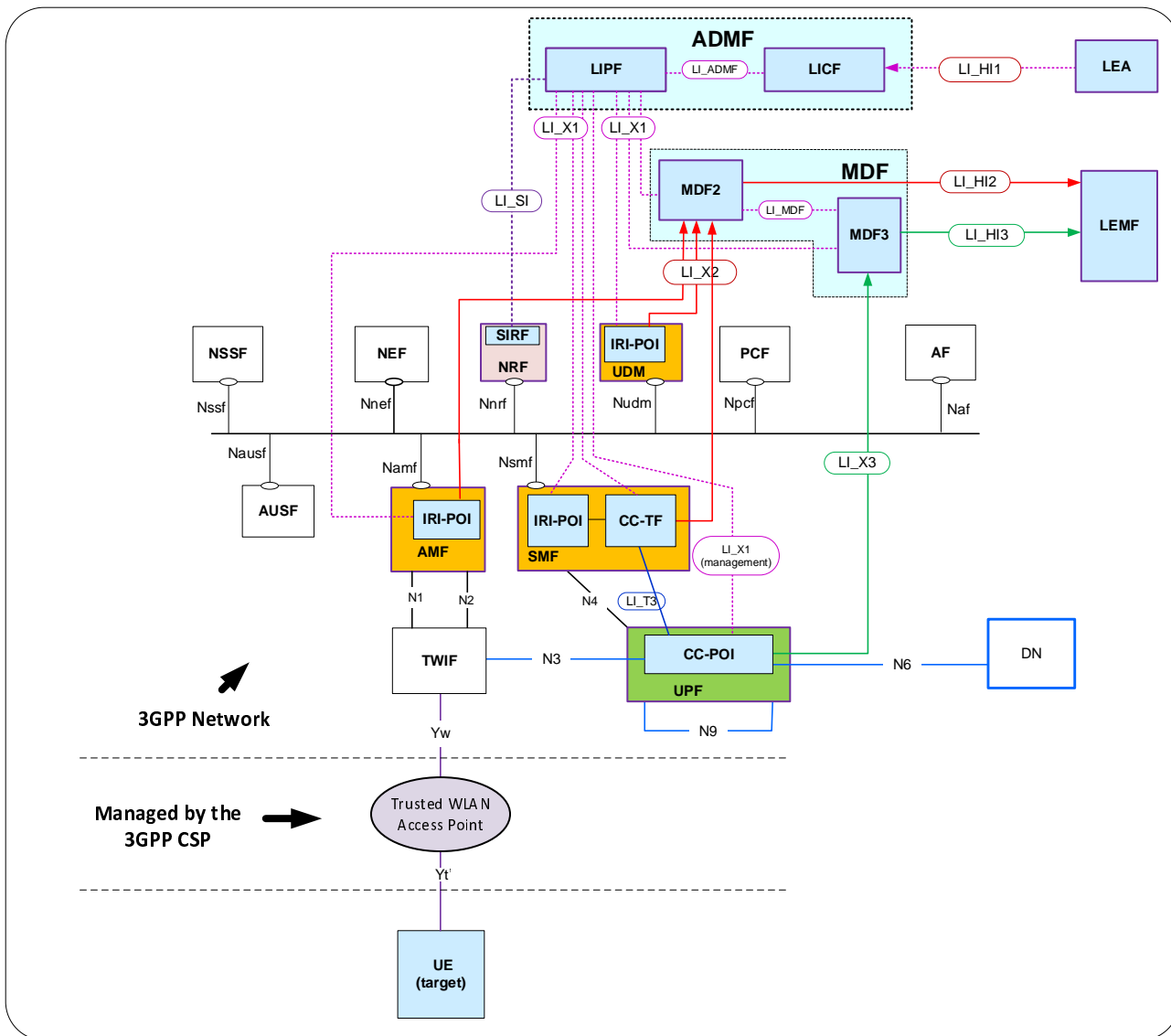

Figure A.4-2: Network topology showing LI for non-3GPP access to 5G via TNGF



**Figure A.4-3: Network topology showing LI for non-3GPP access to 5G via TWIF**

The IRI-POIs present in the AMF, UDM, SMSF and SMF deliver the xIRI to the MDF2 and CC-POI present in the UPF delivers the xCC to the MDF3. The MDF3 address to CC-POI present in UPF is provided by the CC-TF present in the SMF over LI\_T3 reference point.

The LIPF present in the ADMF provisions the IRI-POIs and the CC-TF present in the NFs with the intercept related data. The LI\_X1 interfaces between the LIPF and the UPF is to monitor the user plane data.

---

## Annex B (normative): ADMF functionality

The Administration Function (ADMF) provides the CSP's administrative and management functions for the LI capability.

The ADMF's primary roles and responsibilities include:

- The logical point of contact from the LEA to the CSP via LI\_HI1 for Lawfully authorised requests (e.g. warrant).
- Maintaining the CSP / LEA mutually agreed unique Lawful Interception IDentifier (LIID) for the warrant which is used for all corresponding LI\_HI2, LI\_HI3, and LI\_HI4 communications for warrant correlation.
- CSP administration and local management of the warrant including start/stop times, filter criteria, LEA policy toggles, etc.
- Deriving internal information (ID mappings, potential POIs, etc.) from the warrant.
- For virtualised instances, verifying the authenticity/integrity of CSP LI functions (e.g. LI function's software image) prior to instantiation, see e.g. ETSI NFV-SEC 011 [10] or equivalent.
- When required, providing keys to newly instantiated LI functions to enable decryption of LI specific software.
- LI functions physical location policy control ensuring LI functions are within the legal location policy of the warrant.
- LI Certificate Authority (LI CA, sub-CA of the CSP root CA) for issuing certificates to LI functions as part of their LI provisioning via LI\_X0 interface, see clause 5.6.3.2.
- Provisioning of all required and valid LI functions instantiated by the CSP network.
- Maintaining the master list of all authorised and provisioned LI functions.
- Managing the termination of LI instances across all impacted LI functions when the warrant expires or the LEA specifically requests termination of a LI instance.
- Certificate revoking when the LI function is terminated or the LI function is de-instantiated.
- Maintaining the status of the warrant execution within the CSP (e.g. accepted, pending/provisioning, active, suspended, de-provisioned, etc.).
- As agreed between the LEA and CSP, reporting warrant execution status changes to the LEA as well as responds to warrant audit requests from the LEA.
- Keeping records of the CSP's management of LI related activities (e.g. log files).

Refer to clause 5.4 LI interfaces, and figures 5.4-1 and 5.6-1 for details on specific interfaces between the ADMF and other network functions.

---

## Annex C (informative): LEA initiated suspend and resume

This annex presents a means within current ETSI and 3GPP specifications to support the temporary suspension (suspend) and subsequent resuming (resume) of a Lawful Intercept. Temporary suspension of LI is either directly initiated by the LEA or automatically initiated based on predefined criteria/policy between the LEA and CSP as part of the warrant. This clause only addresses the case of LEA initiated temporary suspension of the delivery of LI product to the LEA.

The underlying baseline is that a Lawful Intercept has been fully authorised and established between the LEA and the CSP via LI\_HI with an agreed LIID to map the warrant to the CSP provided LI product via LI\_HI2, LI\_HI3 and LI\_HI4.

The LEA may request that this active LI instance be temporarily suspended. This means, at a minimum, that the CSP no longer delivers (or buffers) LI product to the LEA.

LEA initiated LI suspension may involve the following steps:

- The LEA, via LI\_HI1, sends an Update Request, referencing the intercept, with the DesiredStatus of Suspended; reference ETSI TS 103 120 [7].
- The ADMF, via LI\_X1, deactivates/deprovisions the required LI Functions, reference ETSI TS 103 221-1 [8]. These LI Functions then locally fully delete the active intercept as required and hence stops any subsequent LI\_HI2/3 delivery.
- The ADMF should maintain all the intercept warrant information of the original intercept, with the status advanced to Suspended.
- The MDFs for which the intercept instance has been de-activated send an LI\_HI4 deactivation notification to the LEMF.
- The ADMF sends an Update Response message to the LEA, via LI\_HI1, with a status of Suspended.

To resume the LI product delivery, this may involve the following steps:

- The LEA sends the CSP, via LI\_H1, an Update Request, referencing the original intercept, with the DesiredStatus of Active. This is equivalent to the initial LI activation but without having to repeat all the warrant information in the original intercept request, and the existing LIID is maintained. Sessions that were active before the intercept suspension that are still active when resumed, or new sessions initiated while the intercept is resumed, are handled as per mid-call intercept activation.
- The ADMF, via LI\_X1, re-provisions the de-activated LI Functions just as for a new intercept to re-instantiate the intercept.

NOTE: This implies all LI Product deliveries will restart just as for a new intercept; e.g. PDU sequence numbers will restart at zero, etc.

- The re-provisioned MDFs send an LI\_HI4 activation notification to the LEMF.
- The ADMF sends an Update Response message to the LEA, via LI\_HI1, with a status of Active.

If the intercept (warrant) timespan expires or the LEA directly requests intercept deactivation while the intercept is in a suspended state, all remaining LI Functions are deactivated/deprovisioned and the rest of LI instance is taken down as per usual warrant deactivation.

---

## Annex D (informative): Additional RCS specific LI details

### D.1 General

The following sub-clauses provide additional details for LI for RCS. Unless specified, the details provided in clause 7.13 apply to all of the following sub-clauses. In general, the specific architecture is used as an example, the location of the POIs may need to be adjusted based on implementation.

The current document defines LI for the following RCS services at the RCS Servers:

- Capability discovery: This service enhances service usability by allowing a user to understand the subset of RCS services available to access and/or communicate with the user's contacts, at certain points in time.
- Pager mode standalone messaging: This service allows delivering one standalone message which does not exceed 1300 bytes in size to one or several recipients. No SIP session is established to deliver that message. The message is carried in a SIP MESSAGE request.
- Large message mode standalone messaging: This service allows delivering one standalone message which is larger than 1300 bytes in size to one or more recipients. A SIP session is established for the delivery of one message only. The message is carried on the user plane.
- 1-to-1 chat: This service allows establishing a SIP session between two participants. This session is used to exchange user plane messages. Unlike large message mode standalone messaging, there is no limit to the number of messages being exchanged.
- Group chat: This service allows establishing a SIP session between several participants. This session is used to exchange user plane messages.
- File URL transfer: Delivery of the URL of a file being uploaded to the HTTP Content Server. The delivery of the URL of the file is performed either by pager mode standalone messaging, large message mode standalone messaging, 1-to-1 chat or group chat.

The current document defines LI for the following RCS services at the HTTP Content Servers:

- File upload. A target UE uploads a file to the HTTP Content Server. If the upload procedure is successful, the target UE is provided with a file transfer message body containing file metadata including the file download URL by the HTTP Content Server.
- File download. A target UE downloads a file or any UE downloads a file uploaded by a target from the HTTP Content Server using a download URL. The URL may have been received via one of the RCS messaging services.

---

## D.2 LI for Registration and Deregistration

### D.2.1 Background

RCS Registration is usually handled by the IMS automatically when a user that is authorised RCS Services registers to the IMS with a UE that supports RCS Services.

### D.2.2 Architecture

The figure 7.13.2-1 without the CC-POI in the RCS Server provides the architecture for LI for capability discovery.

In a normal deployment, the S-CSCF, a Presence Server or Messaging Server may perform the function of the RCS Server in figure 7.13.2-1.

---

## D.3 LI for capability discovery

### D.3.1 Background

The capability or service discovery mechanism in RCS is a process which enhances service usability by allowing a RCS user to exchange its own RCS service capabilities and to understand the RCS service capabilities of another RCS user, at certain points in time.

When available, the RCS specification provides two alternative mechanisms to perform the capability discovery:

- SIP OPTIONS exchange: The SIP OPTIONS end-to-end message is used by one RCS user (e.g., User A) to query the capabilities (services which the other user has available) of the other RCS user (e.g., User B). The SIP OPTIONS message passes the information about which capabilities are supported by User A and the response contains information about which capabilities are supported by User B. Using this method, both users get updated information in a single transaction.
- Presence: In this case, instead of performing an end-to-end transaction, the capabilities are queried against a presence server which is part of the RCS Server as defined in GSMA RCC.07 [35] clause 2.6.1.2.

When the SIP OPTIONS request is used, user A includes user A's RCS capabilities and the IMPU of user B. The response is any of the following:

- SIP 200 OK including at least, one of the tags assigned to the RCS Services. User B is an RCS user. The capabilities returned in the SIP 200 OK response are considered as the current communication options with user B.
- SIP 200 OK not including any of the tags used by RCS services. User B is registered to IMS, but not with an RCS client. User B is not an RCS user. Only the non-RCS communication services (e.g. voice calls, SMS, MMS, etc.) are indicated as available.
- SIP 480 TEMPORARY UNAVAILABLE or 408 REQUEST TIMEOUT returned by the network if user B is an IMS (and potentially thus an RCS) user, but is currently not registered.
- 404 Not Found or 604 Does Not Exist Anywhere. User B is not considered as an IMS user nor an RCS user. Only the non-RCS communication services (e.g., voice calls, SMS, MMS, etc.) are indicated as available.

When presence is used:

- After user A has registered to IMS, User A publishes their RCS capabilities in a Presence document that is published by using the SIP PUBLISH request. If changes are required in the published capabilities (e.g., due to RAT change), a new PUBLISH request is sent. When the client/device is switched off, the published capabilities are removed from the presence server before deregistering from IMS by sending another PUBLISH request.
- When User A wants to use RCS, User A requests the RCS capabilities of user B by sending SIP SUBSCRIBE requests. The Presence server of User B sends a SIP NOTIFY request to User A containing the RCS capabilities of User B.

### D.3.2 Architecture

The figure 7.13.2-1 without the CC-POI in the RCS Server provides the architecture for LI for capability discovery.

In a normal deployment, if SIP OPTIONS are used for capability discovery, the Messaging Server performs the function of the RCS Server in figure 7.13.2-1.

In a normal deployment, if presence is used for capability discovery, the presence server and S-CSCF performs the function of the RCS Server in figure 7.13.2-1.

---

## D.4 LI for standalone messaging

### D.4.1 Background

Standalone messaging is based on the OMA CPM Pager Mode and Large Message Mode mechanisms as described in OMA CPM [34].

When the size of a message does not exceed 1300 bytes, it can be sent as a pager mode standalone message carried directly within the body of a SIP MESSAGE. It may be sent to one or many destinations. Using the SIP MESSAGE method, the message body is CPIM-formatted message as specified in RFC 3862 [38]. The SIP/IP Core provides the routing between the RCS Server and RCS Clients without establishing a SIP session.

The origination of the pager mode standalone message may request to receive a disposition status notification when the message is delivered and/or displayed to the destination of the message. If sent, these messages will follow the reverse path indicated in the message they relate to. These messages may be used for 1-to-1 or 1-to-many pager mode messaging and the notification details are carried within the body of a SIP MESSAGE.

If a standalone message is larger than 1300 bytes, large message mode is used. In large message mode, the contents of the message are not inserted into the SIP message but carried using MSRP as defined in RFC 4975 [36] and RFC 6714 [37]. A SIP session is established between the interested parties (sender and all receivers) with MSRP as the media Stream. The CPIM-formatted messages are then transmitted using MSRP data chunks.

Large Message Mode SIP sessions should not be confused with a chat session as no chat session is established. The SIP session is only used to transmit exactly one large message after which the SIP session is torn down. If delivery and/or display notifications need to be returned by the recipient(s), these notifications are CPIM-formatted messages carried within MSRP data chunks inside the SIP session or within SIP MESSAGEs delivered outside the SIP session as pager mode messages.

### D.4.2 Architecture

The figure 7.13.2-1 provides the architecture for LI for pager mode standalone messaging.

In a normal deployment, the P-CSCF or S-CSCF perform the function of the RCS Server in figure 7.13.2-1.

---

## D.5 LI for chat

### D.5.1 Background

The RCS 1-to-1 chat service and group chat service use SIP procedures for the setup of chat sessions and MSRP for the exchange of user messages as defined in RCC.07 [35] clause 3.2.3. Each MSRP SEND request containing a user message contains a request to receive a delivery notification and possibly a display notification. The client therefore always includes the header field for delivery notification when sending a message. The notifications may be delivered within the 1-to-1 chat session as MSRP SEND requests or outside the 1-to-1 chat session as a pager mode message delivery notification. Multimedia content is not permitted in user messages. Only text/plain user messages can be exchanged.

For the establishment of a group chat session, an RCS user selects at least 2 contacts capable of the chat service. Only ad-hoc groups are authorized. An ad-hoc group is a list of addresses created by the target dynamically. Pre-defined group are not permitted. Extending of a 1-to-1 chat to a group chat is not applicable for the current version of the RCS specification. Users may dynamically add additional participants to a group chat, if they are capable to support chat service.

### D.5.2 Architecture

The figure 7.13.2-1 provides the architecture for LI for 1-to-1 chat.



---

## D.6 LI for file transfer

### D.6.1 Background

When an RCS user desires to send a file to one or more other RCS users, the file URL transfer service is used. The user first uploads the file to a HTTP Content Server, and then uses pager mode standalone messaging, large message mode standalone messaging, 1-to-1 Chat or group chat procedures described in sections D.4 and D.5 respectively to send the URL of the file to the recipient(s).

When using pager mode standalone messaging, the originating client sends the URL of the file in a SIP MESSAGE as a CPIM-formatted message. When using large message mode standalone messaging, 1-to-1 chat or group chat the originating client sends the URIL of the file in MSRP data chunk.

The originating client may request delivery and/or display notification to the recipient(s).

If the recipients send status notification(s), they are sent as CPIM-formatted messages and may be delivered by the recipient in a SIP MESSAGE when using pager mode standalone messaging and in an MSRP data chunk when using large message mode standalone messaging, 1-to-1 chat or group chat.

### D.6.2 Architecture

The figure 7.13.2-1 provides the architecture for LI for file transfer.

# Annex E (informative): STIR/SHAKEN operation

## E.1 General

This annex defines STIR (Secure Telephony Identity Revisited), SHAKEN (Secure Handling of Asserted information using toKENs), eCNAM (Enhanced Calling Name) and RCD (Rich Call Data) and their application to different call scenarios.

## E.2 STIR/SHAKEN

### E.2.1 STIR/SHAKEN for telephony

STIR (Secure Telephony Identity Revisited) and SHAKEN (Secure Handling of Asserted information using toKENs) are the frameworks to prevent the completion of illegally spoofed telephony sessions. Call spoofing is when a session originator changes the calling number to hide or change which calling number is shown on the telephony session display.

STIR provides the ability within SIP to authenticate caller ID, and SHAKEN defines the end-to-end architecture to implement caller ID authentication using STIR in the telephone network.

STIR/SHAKEN uses digital certificates, based on common public key cryptography techniques, to ensure the calling number of a telephony session is secure. Each telephone service provider obtains its digital certificates from a trusted certificate authority. The certificate technology enables verifying that the calling number is accurate and has not been spoofed.

Figure E.2.1-1 below depicts the SHAKEN reference architecture as specified in 3GPP TS 24.229 [39] when using end-to-end SIP signalling.

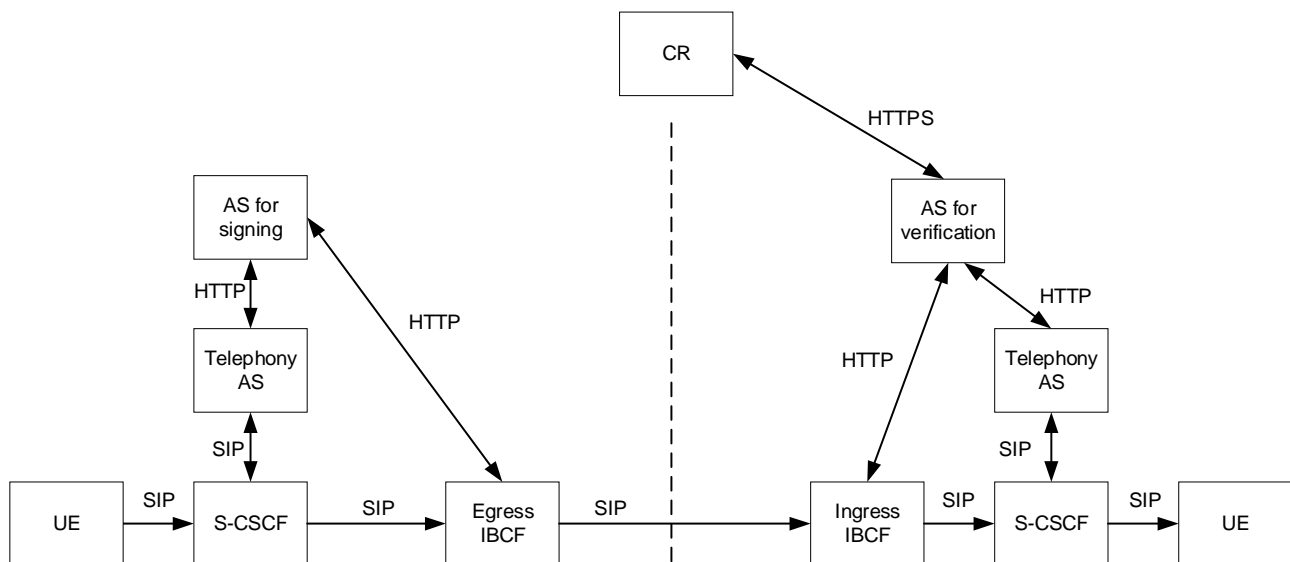

**Figure E.2.1-1: SHAKEN reference architecture for end-to-end SIP signaling**

It is based on IMS architecture. The "application server (AS) for signing" is an HTTP-based application server that performs the function of the authentication service defined in RFC 8224 [40] for originating number identity and in RFC 8946 [41] for diverting number identity. The "AS for verification" is an HTTP-based application server that performs the function of the verification service defined in RFC 8224 [40] and in RFC 8946 [41]. Certificate Repository (CR) represents the publicly accessible store for public key certificates.

Either the Telephony AS or IBCF in the originating service provider's network invokes the AS for signing which creates a digital signature for the call called a PASSporT (Personal Assertion Token) assigned to a SIP Identity header. The IBCF or Telephony AS in the terminating service provider's network invokes the AS for verification which verifies the digital signature of the call. The AS includes a VERSTAT parameter in the P-Asserted-Identity or From header of the SIP INVITE request, with possible values of TN-Validation-Passed, TN-Validation-Failed or No-TN-Validation.

A SIP INVITE request might have one Identity added by an authentication service at the originating administrative domain and then other Identity header fields added by some further intermediaries. The presence of multiple Identity header fields within a SIP INVITE request raises the prospect that a verification service could receive a message containing both valid and invalid Identity header fields. As a guideline, RFC 8224 [40] recommends that only if a verifier determines that all Identity header fields within a message are invalid should the request be considered to have an invalid identity. If at least one Identity header field value is valid and from a trusted source, then relying parties can use that header for authorization decisions regardless of whether other untrusted or invalid Identity headers appear in a request.

## E.2.2 STIR/SHAKEN for intra-network telephony

Some telecommunication regulation authorities may force CSPs implementing STIR/SHAKEN even for intra-network voice sessions. Figure E.2.2-1 depicts the SHAKEN reference architecture for such scenario when using end-to-end SIP signalling. The Telephony AS is the default approach to provide STIR/SHAKEN capabilities, i.e. is capable of invoking the AS for signing on the originating side and AS for verification on the terminating side.

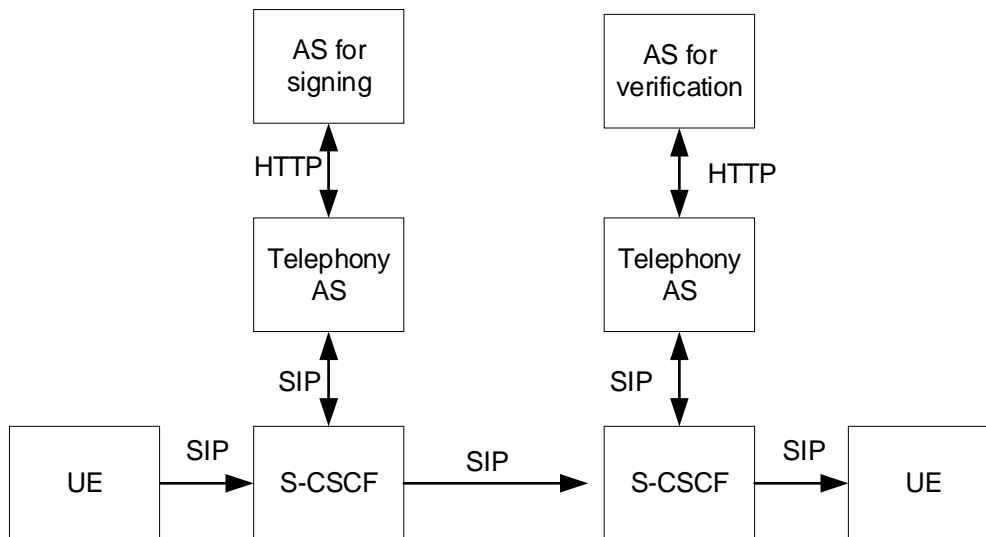

Figure E.2.2-1: SHAKEN reference architecture for intra-network telephony

## E.2.3 STIR/SHAKEN for messaging

STIR/SHAKEN could apply to providing protection for textual and multimedia messaging as specified in an IETF draft *draft-ietf-stir-messaging-00* [46].

A PASSporT could be used to securely negotiate a session over which messages will be exchanged; this is applicable for example to the following RCS services: large message mode standalone messaging, 1-to-1 chat and group chat where messages are exchanged using MSRP (Message Session Relay Protocol) after the SIP session is established. In these scenarios, usage of STIR/SHAKEN is very similar to that for voice sessions.

In sessionless scenarios such as RCS pager mode standalone messaging service, a PASSporT could be generated on a per-message (i.e. SIP MESSAGE) basis with its own built-in message security. An Identity header could be added to any SIP MESSAGE request, but without some extension to the PASSporT claims, the PASSporT would offer no protection to the message content. In IETF draft-ietf-stir-messaging-00 [46], PASSporT provides its own integrity check for message contents as part of its assertions through a new claim which is here defined to provide a hash over message contents. A new "msg" PASSporT Type is defined for that purpose. A new optional claim "msgi" provides a digest over a MIME body (i.e. body of the SIP MESSAGE). The PASSporT is conveyed in an Identity header field in

the SIP MESSAGE request. The authentication and verification service procedures for populating that PASSporT follow the same procedures as for a voice session, with the addition of the "msgi" claim.

## E.2.4 Out of band SHAKEN

In today's PSTN, and for the foreseeable future, the Identity header may fail to arrive at the terminating service provider's network for verification by their AS for verification because the call is not transmitted using SIP end to end. However, Out-of-Band SHAKEN remedies this problem. A possible scenario is described in figure E.2.4-1.

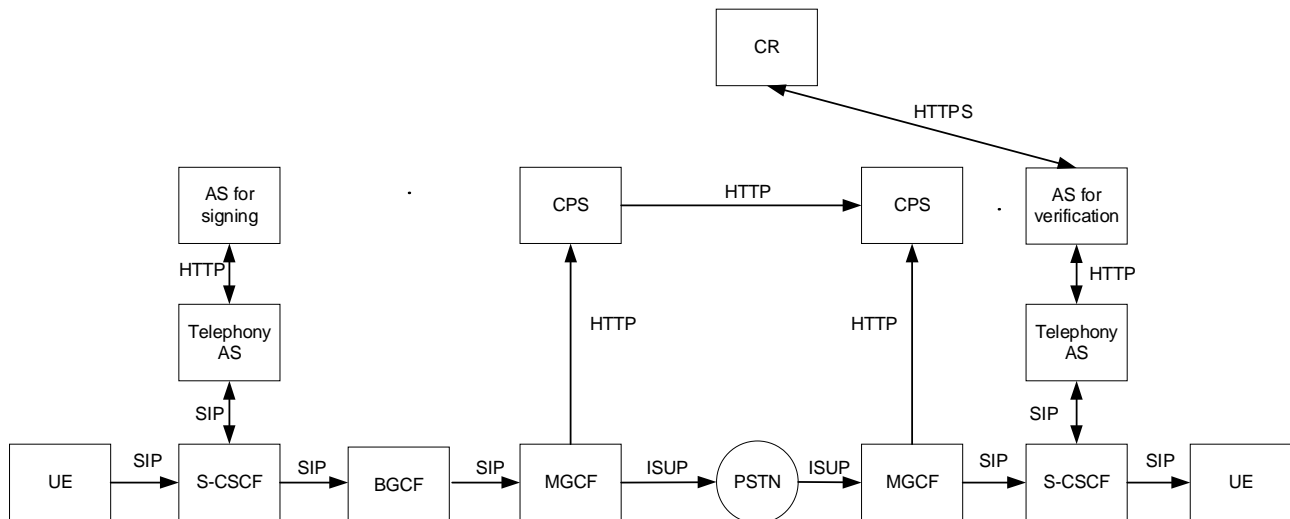

**Figure E.2.4-1: Out of band SHAKEN reference architecture for non end-to-end SIP signaling**

With this solution, the identity token is sent to the terminating service provider separately, out-of-band, through implementation of a Call Placement Service (CPS). All other SHAKEN steps for authentication, use of certificates and verification remain the same. CPS as defined in RFC 8816 [45] permits the identity token to be stored during call processing and retrieved for verification purposes when a session is not using end-to-end SIP signaling, i.e. a leg in the session is using circuit switching and ISUP signaling.

Out-of-Band SHAKEN is used when a service provider wants to use STIR/SHAKEN for a call sent or received across a non-SIP network segment. For example, Out-of-Band SHAKEN would be used in the following situations:

- A service provider originating a call using TDM signaling would generate the applicable PASSporTs using their AS for signing and publish them to a CPS.
- An Intermediate Service Provider converting a session from SIP to TDM would publish all PASSporTs received in SIP signaling for that call to a CPS.
- An Intermediate Service Provider converting a call from TDM to SIP would retrieve all PASSporTs for that call from a CPS and insert them into the SIP signaling for that call.
- A service provider terminating a call using TDM signaling would retrieve all PASSporTs for that call from a CPS and verify the call using their AS for verification.

Service providers originating, transiting, or terminating calls using only SIP signaling do not use Out-of-Band SHAKEN. They use PASSporTs in SIP signaling. Intermediate providers transiting calls with TDM signaling only do not use Out-of-Band SHAKEN. An upstream provider would have already published PASSporTs for those calls to a CPS. There is no need for an all-TDM intermediate provider to do anything as shown in figure E.3.4-2. The interworking function (IWF) is the interface to the AS for signing at the originating side and the interface to the AS for verification at the terminated side.

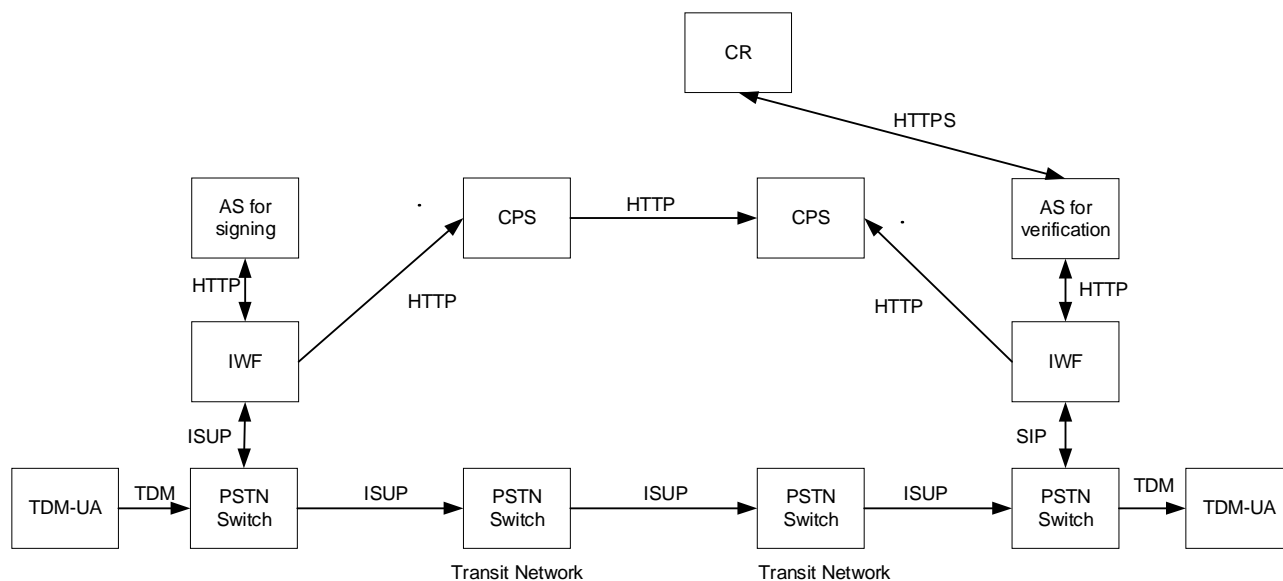

Figure E.2.4-2: Out of band SHAKEN reference architecture for end-to-end TDM signaling

## E.2.5 STIR/SHAKEN and forwarded calls

In case of call forwarding, the original called party number is not the number to which a call is delivered. The SIP headers such as "History-Info", "Diversion" and "To" do not provide any cryptographic assurance of secure redirection. RFC 8946 [41] extends the SIP identity token (i.e. PASSporT) with an explicit indication that the original called number no longer reflects the destination to which a call is intended to be delivered via a "div" parameter. It indicates a previous destination for a session during its routing process. When a retargeting entity receives a call signed with the SIP Identity token, it may act as an authentication service and create a new SIP Identity token containing the "div" parameter to attach to the session.

## E.3 Enhanced caller data

### E.3.1 General

Two approaches, namely Rich Call Data (RCD) and eCNAM (Enhanced Calling Name) build on STIR/SHAKEN to provide additional caller information rendered to the callee during alerting to encourage the callee to answer the session.

### E.3.2 RCD

RCD is described in an IETF draft draft-ietf-stir-passport-rcd-12 [42]. RCD is of two main categories. The first data is a more traditional set of information about a caller associated with "display-name", typically a textual description of the caller in the SIP INVITE. The second category is a set of RCD that is defined as part of the jCard (JSON format for vCard) as specified in RFC 7095 [43]. RCD is inserted in the SIP Identity header token and is digitally signed. If a session is not authenticated and signed then RCD cannot be used. While RCD can be provided by an originating authentication service, an intermediary in the session path could also acquire RCD by querying a third-party service. Such a service effectively acts as a STIR authentication service, generating its own Identity token including RCD, and that token could be attached to a SIP session by either the originating or terminating side.

### E.3.3 eCNAM

The Enhanced Calling Name (eCNAM) service defined in TS 24.196 [44] provides the terminating user with a name that identifies the originating user, and metadata about that originating user (e.g. address, language, etc.), like with RCD. eCNAM data is managed by the originating network and stored in an authoritative database. To enable the terminating network to retrieve eCNAM data, the terminating service provider queries the database using the calling telephone number as the key, to obtain calling display name and other metadata.

In both RCD and eCNAM the terminating network shall populate the received name and received metadata elements in appropriate SIP headers in the INVITE request being forwarded to the terminating UE.

## E.4 STIR/SHAKEN call flow example

The following procedure explains STIR/SHAKEN operation when SIP signaling is carried end-to-end between an originating and terminating service provider as illustrated in figure E.4.1-1.

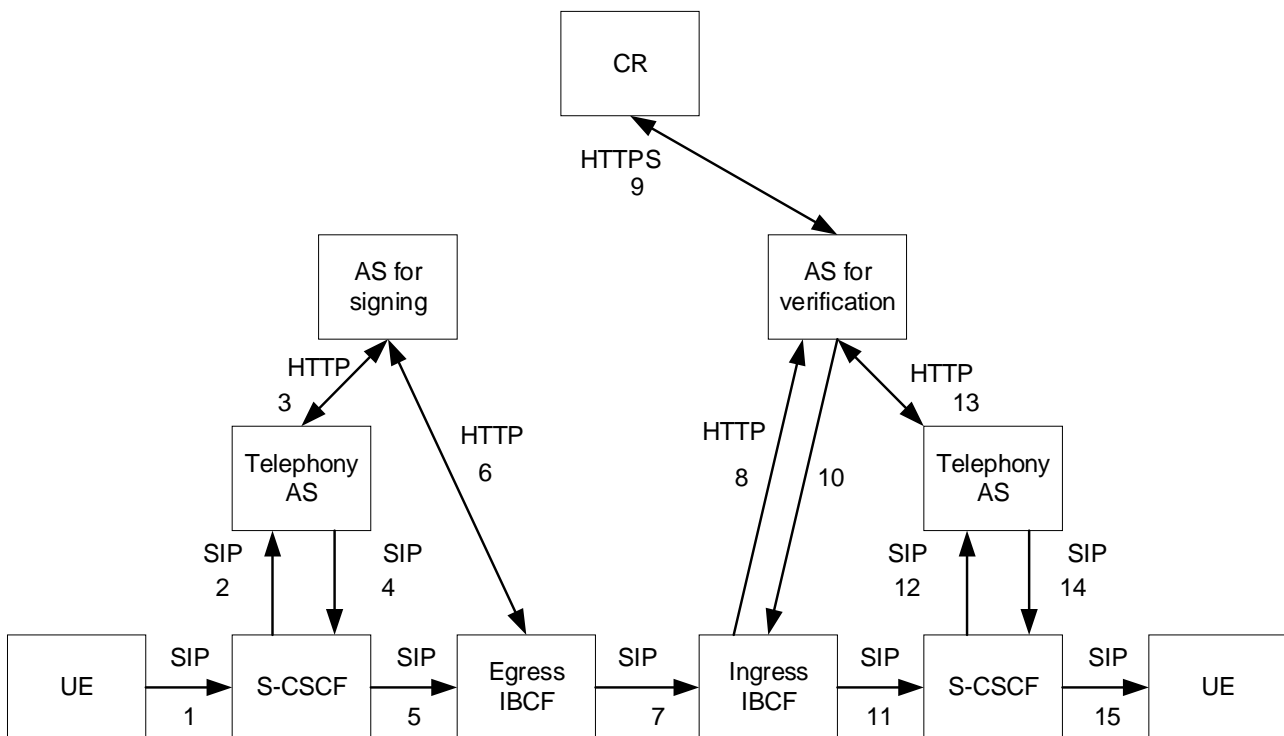

**Figure E.4.1-1: SHAKEN reference call flow using end-to-end SIP signaling**

1. The originating UE, which first successfully registers to IMS creates a SIP INVITE request.
2. The S-CSCF of the originating service provider passes the SIP INVITE request to the Telephony AS.
3. The Telephony AS runs the telephony services related to the originating user and:
  - May send a signing request (HTTP POST request) to the AS for signing. AS for signing using its private key generates an Identity header as defined in RFC 8224 [40] using the Caller ID to attest for the validity of the calling number. The AS for signing returns the signing response (HTTP 200 OK) containing the Identity header to telephony AS. The Telephony AS signs the SIP INVITE request with the SIP Identity header. The Telephony AS also obtains Identity header for each diverting identity as defined in RFC 8946 [41].
  - May not sign the SIP INVITE request with the SIP Identity header if it knows the egress IBCF supports invoking the AS for signing for providing an Identity header field.
4. The Telephony AS passes the SIP INVITE request back to the S-CSCF.
5. The S-CSCF, through standard resolution, routes the telephony session to the egress IBCF.
6. If the egress IBCF does not find an Identity header field in the received SIP INVITE request, the IBCF sends a signing request (HTTP POST request) to the AS for signing. When the response to the request is received, the IBCF shall include the value of the "identity" claim in an Identity header field in the SIP INVITE request. If the SIP INVITE request contains one or more History-Info header fields, that determine that one or several diversions have occurred, the IBCF sends a signing request for each of the identities to be signed if no

corresponding Identity header fields are found in the SIP INVITE request. The IBCF shall include the value of the "identity" claim in an Identity header field in the SIP INVITE request.

7. The SIP INVITE request is routed over the NNI through the standard inter-domain routing configuration. The terminating service provider ingress IBCF receives the SIP INVITE request containing one or more Identity header fields over the NNI.
8. The IBCF uses the identity header fields to build and send a verification request (HTTPS POST request) to the AS for verification related to the originating identity and forwarding identities if the IBCF supports invoking the AS for verification.
9. The AS for verification uses the "x5u" key in the Identity header field to determine the CR Uniform Resource Identifier (URI) and makes an HTTPS request to the CR. The AS for verification validates the certificate and then extracts the public key. It uses the public key to verify the signature in the Identity header field, which validates the Caller ID used when signing the SIP INVITE request on the originating service provider's AS for signing.
10. The AS for verification returns a verification response (200 OK) to the ingress IBCF which adds the verification result (TN-Validation-Passed, TN-Validation-Failed, No-TN-Validation) as a VERSTAT parameter to the P-Asserted-Identity or From header in the SIP INVITE request. The TN-Validation-Failed result is associated with a failure response code to identify the specific error. The standard does not propose any authorization policy to follow based on the presence of a valid Identity header field, the presence of an invalid Identity header field or the absence of an Identity header field. However, it is anticipated that local policies could involve making different forwarding decisions or changing how the user is alerted or how identity is rendered in UE implementations.
11. The ingress IBCF passes the SIP INVITE request to the terminating S-CSCF.
12. The terminating S-CSCF passes the SIP INVITE request to the terminating Telephony AS.
13. If the verification has not been performed by the ingress IBCF, the Telephony AS runs the verification procedure toward the AS for verification before running the telephony services related to the terminating identity.
14. If the validation is successful, the SIP INVITE request is passed back to the terminating S-CSCF which continues to set up the session to the terminating UE.
15. The terminating UE receives the SIP INVITE request and normal SIP processing of the session continues.

## Annex Z (informative): Change history

Change history							
Date	Meeting	TDoc	CR	Rev	Cat	Subject/Comment	New version
2018-12	SA#82	SP-180991				Release 15 draft Approved at TSG SA#82	15.0.0
2019-03	SA#83	SP-190042	0001	1	F	LI Support for VoNR in R15	15.1.0
2019-03	SA#83	SP-190042	0003	1	F	Virtualised EPC Clarification	15.1.0
2019-03	SA#83	SP-190042	0006	-	F	Non-3GPP Access IP Address	15.1.0
2019-06	SA#84	SP-190343	0014	1	B	SecondaryCellGroupPSCell Reporting	15.2.0
2019-06	SA#84	SP-190345	0015	1	F	Missing references	15.2.0
2019-06	SA#84	SP-190344	0010	1	F	Usage of LIID and other parameters	16.0.0
2019-06	SA#84	SP-190344	0011	1	B	Coverage of subscriber de-provisioning while under a warrant	16.0.0
2019-06	SA#84	SP-190346	0019	2	C	Introducing CC POI Aggregator for 5GC LI	16.0.0
2019-09	SA#85	SP-190635	0028	1	F	Minor corrections to TS 33.127	16.1.0
2019-09	SA#85	SP-190635	0029	1	F	Editorial fixes to pass consistency check	16.1.0
2019-09	SA#85	SP-190635	0030	1	F	Fix pic for CC POI Aggregator for 5GC LI	16.1.0
2019-09	SA#85	SP-190635	0032	2	C	Introductory clause for IMS from the pCR	16.1.0
2019-09	SA#85	SP-190635	0033	1	F	Additional text to the IMS clause	16.1.0
2019-09	SA#85	SP-190635	0034	1	B	Updated architecture figures	16.1.0
2019-09	SA#85	SP-190635	0035	1	B	IMS Architecture Figures	16.1.0
2019-09	SA#85	SP-190635	0036	1	F	Support for MMS	16.1.0
2019-09	SA#85	SP-190661	0038	1	A	Removal of notes on LI_X2 and LI_X3	16.1.0
2019-09	SA#85	SP-190662	0040	3	C	LI Virtualisation Procedures	16.1.0
2019-09	SA#85	SP-190662	0044	1	B	LI in VPLMN with home routed roaming scenario	16.1.0
2019-12	SA#86	SP-190985	0047	1	B	Porting LI for EPC into TS 33.127	16.2.0
2019-12	SA#86	SP-190985	0049	1	B	Support for PTC Stage 2	16.2.0
2019-12	SA#86	SP-190985	0056	1	D	Editorial name change for ETSI TS 103 221-x references	16.2.0
2020-03	SA#87	SP-200031	0057	1	F	LI in VPLMN with home routed roaming scenario – updates to the common part	16.3.0
2020-03	SA#87	SP-200031	0058	1	F	LI in VPLMN with home routed roaming scenario – S8HR LI	16.3.0
2020-03	SA#87	SP-200031	0059	1	F	LI in VPLMN with home routed roaming scenario – N9HR LI	16.3.0
2020-03	SA#87	SP-200031	0060	2	C	ADMF descriptive details	16.3.0
2020-03	SA#87	SP-200031	0061	2	B	Support of manual LI Suspend and Resume	16.3.0
2020-03	SA#87	SP-200030	0063	-	A	Correction of the MLP reference	16.3.0
2020-03	SA#87	SP-200031	0064	1	F	MMS Stage 2	16.3.0
2020-03	SA#87	SP-200031	0065	1	F	CC-PAG provisioning and deployment corrections	16.3.0
2020-07	SA#88-e	SP-200407	0069	-	F	Fixing the typos	16.4.0
2020-07	SA#88-e	SP-200407	0070	1	F	Clarifications on the NFs that provide POI/TF functions for conferencing	16.4.0
2020-07	SA#88-e	SP-200407	0072	2	C	Virtualisation details	16.4.0
2020-07	SA#88-e	SP-200407	0073	-	F	Fixing the incorrect internal references	16.4.0
2020-07	SA#88-e	SP-200407	0074	-	F	Clarification to the IMS clause for the legacy CC-POI functions	16.4.0
2020-09	SA#89-e	SP-200807	0076	-	F	Correction on LI_X3_LITE_M interface	16.5.0
2020-09	SA#89-e	SP-200807	0078	1	F	Porting of HSS LI stage 2 from TS 33.107 to TS 33.127	16.5.0
2020-09	SA#89-e	SP-200807	0079	1	F	Clarification on the LI architecture	16.5.0
2020-09	SA#89-e	SP-200807	0086	1	F	One PDU session connects to only one DN	16.5.0
2020-09	SA#89-e	SP-200807	0088	1	F	MA-PDU LI at the SMF	16.5.0
2020-09	SA#89-e	SP-200807	0089	1	F	Addition of DNAI to SA PDU Reporting	16.5.0
2020-09	SA#89-e	SP-200807	0090	1	F	MA-PDU LI requirements at the AMF	16.5.0
2020-09	SA#89-e	SP-200807	0091	1	F	Clarification of LMF and GMLC Event Reporting at the AMF	16.5.0
2020-12	SA#90-e	SP-200940	0092	-	F	Missing functional requirements on logging at ADMF	16.6.0
2020-12	SA#90-e	SP-200940	0094	1	C	ADMF LI Function Targeting	16.6.0
2020-12	SA#90-e	SP-200940	0095	1	F	Corrections to specify non-local ID as a target type rather than as target identifier	16.6.0
2020-12	SA#90-e	SP-200940	0096	1	B	Enhancement for Subscriber Record Change	16.6.0
2020-12	SA#90-e	SP-200940	0097	3	B	Identifier Association	16.6.0
2020-12	SA#90-e	SP-200940	0098	1	F	Corrections to the architecture for SMF/UPF	16.6.0
2020-12	SA#90-e	SP-200940	0099	-	F	Changes to the architecture in the EPC clause	16.6.0
2020-12	SA#90-e	SP-200940	0100	-	F	Changes to the architecture diagrams in the LALS clause	16.6.0
2021-03	SA#91-e	SP-210031	0102	2	F	GUTI allocation procedure reporting correction	16.7.0
2021-03	SA#91-e	SP-210031	0110	1	F	IMS LI: Alternate option has potentially missing IRI-POI for certain scenarios	16.7.0
2021-03	SA#91-e	SP-210031	0111	1	F	IMS LI: Independent default/alternate option for non-local ID targets	16.7.0
2021-03	SA#91-e	SP-210031	0112	1	F	IMS LI: Separate LI_X1 to CC-TF and IRI-POI when in the same NF	16.7.0
2021-03	SA#91-e	SP-210032	0107	1	C	Clarification on ID Mapping Location Delivery	17.0.0
2021-03	SA#91-e	SP-210032	0109	1	F	Port of EPC MME Target Identifiers	17.0.0
2021-06	SA#92-e	SP-210303	0113	-	F	LALS: Correcting the diagrams	17.1.0



Change history							
Date	Meeting	TDoc	CR	Rev	Cat	Subject/Comment	New version
2021-06	SA#92-e	SP-210302	0115	-	A	UDM: Stage 2 and stage 3 are not aligned	17.1.0
2021-06	SA#92-e	SP-210303	0118	1	F	IMS: clarifying the introductory sentence for accuracy	17.1.0
2021-06	SA#92-e	SP-210303	0119	1	B	IMS: Addressing the interception due to the application of special media	17.1.0
2021-06	SA#92-e	SP-210303	0120	1	B	IMS: SMS over IMS in stage 2	17.1.0
2021-06	SA#92-e	SP-210303	0122	3	C	IMS: Removing IBCF from the alternate option for non-local ID in the VPLMN	17.1.0
2021-06	SA#92-e	SP-210303	0123	1	C	Port of EPC MME LI	17.1.0
2021-06	SA#92-e	SP-210303	0125	1	C	LALS Updates 127	17.1.0
2021-06	SA#92-e	SP-210303	0127	2	B	LI for NEF Services (NIDD included)	17.1.0
2021-06	SA#92-e	SP-210303	0128	2	B	LI for SCEF services	17.1.0
2021-06	SA#92-e	SP-210302	0130	1	A	Addition of TWIF and TNGF as Non-3GPP Accesses	17.1.0
2021-06	SA#92-e	SP-210303	0132	2	B	Correction to LI Architecture for the SGW/PGW	17.1.0
2021-06	SA#92-e	SP-210303	0133	1	F	Changes to align stage 2 and stage 3 PTC service	17.1.0
2021-06	SA#92-e	SP-210302	0134	-	A	LI state transfers in SMF sets	17.1.0
2021-09	SA#93-e	SP-210829	0135	4	B	stage 2 of RCS	17.2.0
2021-09	SA#93-e	SP-210829	0136	5	B	STIR/SHAKEN/eCNAM/RCD in Stage 2	17.2.0
2021-09	SA#93-e	SP-210828	0138	-	A	Correction of Caching Duration Setting Guidance	17.2.0
2021-09	SA#93-e	SP-210829	0139	-	C	Clarification of Non-3GPP access reporting	17.2.0
2021-09	SA#93-e	SP-210829	0140	1	B	CR adding LI for AKMA (stage 2)	17.2.0
2021-09	SA#93-e	SP-210829	0141	1	C	Annex A.1 and A.2 Corrections for 33.127	17.2.0
2021-09	SA#93-e	SP-210829	0142	1	F	Changes to align stage 2 and stage 3 PTC service	17.2.0
2021-09	SA#93-e	SP-210829	0144	1	F	Update of stage 2 language for packet header information reporting	17.2.0
2021-09	SA#93-e	SP-210829	0145	1	F	Changes to 5G core-anchored LI architecture figure	17.2.0
2021-09	SA#93-e	SP-210829	0146	1	F	Changes to EPC/5G Interworking LI architecture figure	17.2.0
2021-09	SA#93-e	SP-210829	0148	-	F	Correction of LI architecture for LI at the ePDG	17.2.0
2021-12	SA#94-e	SP-211409	0152	-	F	Wrong stage 2 normative text of identifier association xIRI for the IRI-POI in the AMF and MME	17.3.0
2021-12	SA#94-e	SP-211409	0153	1	B	LI for EPC-5GC Interworking Stage 2	17.3.0
2021-12	SA#94-e	SP-211409	0154	1	F	IMS stage 2 clarification due to STIR/SHAKEN and RCD/eCNAM	17.3.0
2021-12	SA#94-e	SP-211409	0155	-	F	IMS stage 2 clarification on PBX target identities	17.3.0
2021-12	SA#94-e	SP-211409	0156	-	C	GPSI for AIC - State 2	17.3.0
2022-03	SA#95-e	SP-220258	0157	1	B	Enhancements to LI at the UDM Stage 2	17.4.0
2022-03	SA#95-e	SP-220258	0159	1	C	Updates to Stage 2 RCS Topologies and IMS utilisation	17.4.0
2022-03	SA#95-e	SP-220258	0160	2	C	Measurement Report with LI/LALS in EPC	17.4.0
2022-03	SA#95-e	SP-220258	0161	2	C	Measurement Report with LI/LALS in 5GC	17.4.0
2022-03	SA#95-e	SP-220258	0162	1	C	Enhancement of LI/LALS system in VPLMN	17.4.0
2022-03	SA#95-e	SP-220258	0163	1	F	Corrections and Editorial changes	17.4.0
2022-06	SA#96	SP-220386	0165	1	F	Inconsistent use of IEF, ICF and IQF terminology	17.5.0
2022-06	SA#96	SP-220386	0168	-	D	Correction and homogenization of terms designating UE	17.5.0
2022-06	SA#96	SP-220386	0170	1	C	Corrections to LI for combined SMF+PGW-C	17.5.0
2022-06	SA#96	SP-220386	0171	-	F	Correction of IMEI Target Identifier description	17.5.0
2022-06	SA#96	SP-220386	0172	-	F	Clarification of Location Translation Stage 2	17.5.0
2022-09	SA#97-e	SP-220755	0177	-	F	Corrections to LI at UDM	17.6.0
2022-09	SA#97-e	SP-220755	0179	1	B	Support of location information request for both T2P and P2T requests in alignment with TS 33.128	17.6.0

---

# History

<b>Document history</b>		
V17.4.0	May 2022	Publication
V17.5.0	July 2022	Publication
V17.6.0	September 2022	Publication