

ETSI TS 133 401 V16.3.0 (2020-08)



**Digital cellular telecommunications system (Phase 2+) (GSM);
Universal Mobile Telecommunications System (UMTS);
LTE;
3GPP System Architecture Evolution (SAE);
Security architecture
(3GPP TS 33.401 version 16.3.0 Release 16)**



Reference

RTS/TSGS-0333401vg30

Keywords

GSM,LTE,SECURITY,UMTS

ETSI

650 Route des Lucioles
F-06921 Sophia Antipolis Cedex - FRANCE

Tel.: +33 4 92 94 42 00 Fax: +33 4 93 65 47 16

Siret N° 348 623 562 00017 - NAF 742 C
Association à but non lucratif enregistrée à la
Sous-Préfecture de Grasse (06) N° 7803/88

Important notice

The present document can be downloaded from:

<http://www.etsi.org/standards-search>

The present document may be made available in electronic versions and/or in print. The content of any electronic and/or print versions of the present document shall not be modified without the prior written authorization of ETSI. In case of any existing or perceived difference in contents between such versions and/or in print, the prevailing version of an ETSI deliverable is the one made publicly available in PDF format at www.etsi.org/deliver.

Users of the present document should be aware that the document may be subject to revision or change of status.

Information on the current status of this and other ETSI documents is available at

<https://portal.etsi.org/TB/ETSIDeliverableStatus.aspx>

If you find errors in the present document, please send your comment to one of the following services:

<https://portal.etsi.org/People/CommiteeSupportStaff.aspx>

Copyright Notification

No part may be reproduced or utilized in any form or by any means, electronic or mechanical, including photocopying and microfilm except as authorized by written permission of ETSI.

The content of the PDF version shall not be modified without the written authorization of ETSI.

The copyright and the foregoing restriction extend to reproduction in all media.

© ETSI 2020.

All rights reserved.

DECT™, **PLUGTESTS™**, **UMTS™** and the ETSI logo are trademarks of ETSI registered for the benefit of its Members.

3GPP™ and **LTE™** are trademarks of ETSI registered for the benefit of its Members and of the 3GPP Organizational Partners.

oneM2M™ logo is a trademark of ETSI registered for the benefit of its Members and of the oneM2M Partners.

GSM® and the GSM logo are trademarks registered and owned by the GSM Association.

Intellectual Property Rights

Essential patents

IPRs essential or potentially essential to normative deliverables may have been declared to ETSI. The information pertaining to these essential IPRs, if any, is publicly available for **ETSI members and non-members**, and can be found in ETSI SR 000 314: "*Intellectual Property Rights (IPRs); Essential, or potentially Essential, IPRs notified to ETSI in respect of ETSI standards*", which is available from the ETSI Secretariat. Latest updates are available on the ETSI Web server (<https://ipr.etsi.org/>).

Pursuant to the ETSI IPR Policy, no investigation, including IPR searches, has been carried out by ETSI. No guarantee can be given as to the existence of other IPRs not referenced in ETSI SR 000 314 (or the updates on the ETSI Web server) which are, or may be, or may become, essential to the present document.

Trademarks

The present document may include trademarks and/or tradenames which are asserted and/or registered by their owners. ETSI claims no ownership of these except for any which are indicated as being the property of ETSI, and conveys no right to use or reproduce any trademark and/or tradename. Mention of those trademarks in the present document does not constitute an endorsement by ETSI of products, services or organizations associated with those trademarks.

Legal Notice

This Technical Specification (TS) has been produced by ETSI 3rd Generation Partnership Project (3GPP).

The present document may refer to technical specifications or reports using their 3GPP identities. These shall be interpreted as being references to the corresponding ETSI deliverables.

The cross reference between 3GPP and ETSI identities can be found under <http://webapp.etsi.org/key/queryform.asp>.

Modal verbs terminology

In the present document "**shall**", "**shall not**", "**should**", "**should not**", "**may**", "**need not**", "**will**", "**will not**", "**can**" and "**cannot**" are to be interpreted as described in clause 3.2 of the [ETSI Drafting Rules](#) (Verbal forms for the expression of provisions).

"**must**" and "**must not**" are **NOT** allowed in ETSI deliverables except when used in direct citation.

Contents

Intellectual Property Rights	2
Legal Notice	2
Modal verbs terminology.....	2
Foreword.....	10
1 Scope	11
2 References	11
3 Definitions, symbols and abbreviations	13
3.1 Definitions	13
3.2 Symbols.....	15
3.3 Abbreviations	15
3.4 Conventions.....	17
4 Overview of Security Architecture.....	17
5 Security Features	18
5.1 User-to-Network security	18
5.1.0 General.....	18
5.1.1 User identity and device confidentiality	18
5.1.2 Entity authentication	18
5.1.3 User data and signalling data confidentiality	18
5.1.3.1 Ciphering requirements.....	18
5.1.3.2 Algorithm Identifier Values	19
5.1.4 User data and signalling data integrity.....	19
5.1.4.1 Integrity requirements	19
5.1.4.2 Algorithm Identifier Values	20
5.2 Security visibility and configurability	20
5.3 Security requirements on eNodeB.....	20
5.3.1 General.....	20
5.3.2 Requirements for eNB setup and configuration.....	20
5.3.3 Requirements for key management inside eNB.....	21
5.3.4 Requirements for handling User plane data for the eNB	21
5.3.4a Requirements for handling Control plane data for the eNB.....	21
5.3.5 Requirements for secure environment of the eNB	22
5.4 Void.....	22
6 Security Procedures between UE and EPC Network Elements	22
6.0 General	22
6.1 Authentication and key agreement	22
6.1.1 AKA procedure.....	22
6.1.2 Distribution of authentication data from HSS to serving network.....	24
6.1.3 User identification by a permanent identity	24
6.1.4 Distribution of IMSI and authentication data within one serving network domain	25
6.1.5 Distribution of IMSI and authentication data between different serving network domains.....	26
6.1.6 Distribution of IMSI and UMTS authentication vectors between MMEs or between MME and SGSN	26
6.2 EPS key hierarchy	27
6.3 EPS key identification	29
6.4 Handling of EPS security contexts	30
6.5 Handling of NAS COUNTs.....	31
7 Security procedures between UE and EPS access network elements	32
7.0 General	32
7.1 Mechanism for user identity confidentiality.....	32
7.2 Handling of user-related keys in E-UTRAN	32
7.2.1 E-UTRAN key setting during AKA	32
7.2.2 E-UTRAN key identification.....	32

7.2.3	E-UTRAN key lifetimes	33
7.2.4	Security mode command procedure and algorithm negotiation.....	33
7.2.4.1	Requirements for algorithm selection	33
7.2.4.2	Procedures for AS algorithm selection.....	34
7.2.4.2.1	Initial AS security context establishment	34
7.2.4.2.2	X2-handover	34
7.2.4.2.3	S1-handover.....	34
7.2.4.2.4	Intra-eNB handover	34
7.2.4.3	Procedures for NAS algorithm selection.....	34
7.2.4.3.1	Initial NAS security context establishment	34
7.2.4.3.2	MME change	35
7.2.4.4	NAS security mode command procedure.....	35
7.2.4.5	AS security mode command procedure.....	36
7.2.4a	Algorithm negotiation for unauthenticated UEs in LSM	37
7.2.5	Key handling at state transitions to and away from EMM-DEREGISTERED	38
7.2.5.1	Transition to EMM-DEREGISTERED.....	38
7.2.5.2	Transition away from EMM-DEREGISTERED.....	39
7.2.5.2.1	General	39
7.2.5.2.2	With existing native EPS NAS security context.....	39
7.2.5.2.3	With run of EPS AKA	40
7.2.6	Key handling in ECM-IDLE to ECM-CONNECTED and ECM-CONNECTED to ECM-IDLE transitions.....	40
7.2.6.1	ECM-IDLE to ECM-CONNECTED transition.....	40
7.2.6.2	Establishment of keys for cryptographically protected radio bearers	40
7.2.6.3	ECM-CONNECTED to ECM-IDLE transition.....	41
7.2.7	Key handling for the TAU procedure when registered in E-UTRAN	41
7.2.8	Key handling in handover.....	42
7.2.8.1	General	42
7.2.8.1.1	Access stratum.....	42
7.2.8.1.2	Non access stratum	43
7.2.8.2	Void.....	43
7.2.8.3	Key derivations for context modification procedure.....	43
7.2.8.4	Key derivations during handovers.....	44
7.2.8.4.1	Intra-eNB Handover	44
7.2.8.4.2	X2-handover	44
7.2.8.4.3	S1-Handover.....	44
7.2.8.4.4	UE handling.....	45
7.2.9	Key-change-on-the fly	45
7.2.9.1	General	45
7.2.9.2	K _{eNB} re-keying.....	45
7.2.9.3	KeNB refresh	46
7.2.9.4	NAS key re-keying.....	46
7.2.10	Rules on Concurrent Running of Security Procedures	47
7.2.11	Suspend and resume of RRC connection	48
7.2.11.1	General	48
7.2.11.2	RRC connection suspend	48
7.2.11.3	RRC connection resume to a new eNB	48
7.2.11.4	RRC connection resume to the same eNB	50
7.3	UP security mechanisms	50
7.3.1	UP confidentiality mechanisms	50
7.3.2	UP integrity mechanisms	50
7.4	RRC security mechanisms.....	51
7.4.1	RRC integrity mechanisms	51
7.4.2	RRC confidentiality mechanisms	51
7.4.3	K _{eNB} * and Token Preparation for the RRCConnectionRe-establishment Procedure	51
7.4.4	RRCConnectionRe-establishment Procedure for Control Plane CIoT EPS optimisation.....	52
7.4.5	RRC UE capability transfer procedure	53
7.5	Signalling procedure for periodic local authentication.....	53
8	Security mechanisms for non-access stratum signalling and data via MME	54
8.0	General	54
8.1	NAS integrity mechanisms.....	54

8.1.1	NAS input parameters and mechanism.....	54
8.1.2	NAS integrity activation.....	55
8.2	NAS confidentiality mechanisms.....	55
9	Security interworking between E-UTRAN and UTRAN.....	56
9.1	RAU and TAU procedures.....	56
9.1.1	RAU procedures in UTRAN.....	56
9.1.2	TAU procedures in E-UTRAN.....	57
9.2	Handover.....	58
9.2.1	From E-UTRAN to UTRAN.....	58
9.2.2	From UTRAN to E-UTRAN.....	59
9.2.2.1	Procedure.....	59
9.2.2.2	Derivation of NAS keys and K_{eNB} during Handover from UTRAN to E-UTRAN.....	64
9.3	Recommendations on AKA at IRAT-mobility to E-UTRAN.....	64
9.4	Attach procedures.....	65
9.4.1	Attach in UTRAN.....	65
10	Security interworking between E-UTRAN and GERAN.....	65
10.1	General.....	65
10.2	RAU and TAU procedures.....	66
10.2.1	RAU procedures in GERAN.....	66
10.2.2	TAU procedures in E-UTRAN.....	66
10.3	Handover.....	66
10.3.1	From E-UTRAN to GERAN.....	66
10.3.2	From GERAN to E-UTRAN.....	66
10.3.2.1	Procedures.....	66
10.4	Recommendations on AKA at IRAT-mobility to E-UTRAN.....	66
10.5	Attach procedures.....	67
10.5.1	Attach in GERAN.....	67
11	Network Domain Control Plane protection.....	67
12	Backhaul link user plane protection.....	67
13	Management plane protection over the S1 interface.....	68
14	SRVCC between E-UTRAN and Circuit Switched UTRAN/GERAN.....	69
14.1	From E-UTRAN to Circuit Switched UTRAN/GERAN.....	69
14.2	Emergency call in SRVCC from E-UTRAN to circuit switched UTRAN/GERAN.....	70
14.3	SRVCC from circuit switched UTRAN/GERAN to E-UTRAN.....	70
14.3.1	Procedure.....	70
15	Security Aspects of IMS Emergency Session Handling.....	73
15.1	General.....	73
15.2	Security procedures and their applicability.....	74
15.2.1	Authenticated IMS Emergency Sessions.....	74
15.2.1.1	General.....	74
15.2.1.2	UE and MME share a current security context.....	74
15.2.2	Unauthenticated IMS Emergency Sessions.....	75
15.2.2.1	General.....	75
15.2.2.2	UE and MME share no security context.....	76
15.2.3	Void.....	77
15.2.4	Key generation procedures for unauthenticated IMS Emergency Sessions.....	77
15.2.4.1	General.....	77
15.2.4.2	Handover.....	77
16	Void.....	77
Annex A (normative): Key derivation functions.....		78
A.1	KDF interface and input parameter construction.....	78
A.1.1	General.....	78
A.1.2	FC value allocations.....	78
A.2	K_{ASME} derivation function.....	78

A.3	K_{eNB} derivation function	79
A.4	NH derivation function.....	79
A.5	K_{eNB}^* derivation function	79
A.6	Void.....	79
A.7	Algorithm key derivation functions	80
A.8	K_{ASME} to CK' , IK' derivation at handover.....	80
A.9	NAS token derivation for inter-RAT mobility	81
A.10	K'_{ASME} from CK , IK derivation during handover.....	81
A.11	K'_{ASME} from CK , IK derivation during idle mode mobility	81
A.12	$K_{ASME(SRVCC)}$ to CK_{SRVCC} , IK_{SRVCC} derivation.....	82
A.13	K_{ASME} to CK' , IK' derivation at idle mobility	82
A.14	(Void)	82
A.15	Derivation of $S-K_{eNB}$ or $S-K_{gNB}$ for dual connectivity.....	82
A.16	Derivation of LWIP-PSK	82
A.17	Derivation of K_n for IOPS subscriber key separation.....	83
A.18	Derivation of $S-K_{WT}$ for LWA	83
A.19	Key derivation function for key used in algorithms between UE and SgNB.....	83
Annex B (normative): Algorithms for ciphering and integrity protection		84
B.0	Null ciphering and integrity protection algorithms	84
B.1	128-bit ciphering algorithm.....	84
B.1.1	Inputs and outputs	84
B.1.2	128-EEA1	85
B.1.3	128-EEA2.....	85
B.1.4	128-EEA3.....	85
B.2	128-Bit integrity algorithm.....	86
B.2.1	Inputs and outputs	86
B.2.2	128-EIA1	86
B.2.3	128-EIA2.....	86
B.2.4	128-EIA3.....	87
Annex C (informative): Algorithm test data		88
C.1	128-EEA2.....	88
C.1.1	Test Set 1	88
C.1.2	Test Set 2.....	89
C.1.3	Test Set 3.....	90
C.1.4	Test Set 4.....	90
C.1.5	Test Set 5.....	91
C.1.6	Test Set 6.....	92
C.2	128-EIA2.....	95
C.2.1	Test Set 1	96
C.2.2	Test Set 2.....	97
C.2.3	Test Set 3.....	98
C.2.4	Test Set 4.....	99
C.2.5	Test Set 5.....	100
C.2.6	Test Set 6.....	101
C.2.7	Test Set 7.....	103
C.2.8	Test Set 8.....	105

C.3	128-EEA1	117
C.4	128-EIA1	117
C.4.1	Test Set 1	117
C.4.2	Test Set 2	118
C.4.3	Test Set 3	118
C.4.4	Test Set 4	118
C.4.5	Test Set 5	119
C.4.6	Test Set 6	119
C.4.7	Test Set 7	119
Annex D (normative): Security for Relay Node Architectures.....		122
D.1	Introduction	122
D.2	Solution	122
D.2.1	General	122
D.2.2	Security Procedures	122
D.2.3	USIM Binding Aspects	125
D.2.4	Enrolment procedures for RNs	125
D.2.5	Secure management procedures for RNs	126
D.2.6	Certificate and subscription handling	126
D.3	Secure channel profiles	128
D.3.1	General	128
D.3.2	APDU secure channel profile	128
D.3.3	Key agreement based on certificate exchange	128
D.3.3.1	TLS profile	128
D.3.3.2	Common profile for RN and UICC certificate	128
D.3.3.3	RN certificate profile	129
D.3.3.4	UICC certificate profile	129
D.3.4	Key agreement for pre-shared key (psk) case	129
D.3.5	Identities used in key agreement	130
Annex E (normative): Dual connectivity.....		131
E.1	Introduction	131
E.1.1	General	131
E.1.2	Dual Connectivity architecture with an SeNB	131
E.1.3	Dual Connectivity architecture with an SgNB	132
E.2	Dual connectivity offload architecture between eNBs	133
E.2.1	Protection of the X2 reference point	133
E.2.2	Addition and modification of DRB in SeNB	133
E.2.3	Activation of encryption/decryption	134
E.2.4	Derivation of keys for the DRBs in the SeNB	135
E.2.4.1	SCG Counter maintenance	135
E.2.4.2	Security key derivation	135
E.2.4.3	Negotiation of security algorithms	136
E.2.5	S-K _{eNB} update	136
E.2.5.1	S-K _{eNB} update triggers	136
E.2.5.2	S-K _{eNB} update procedure	136
E.2.6	Handover procedures	136
E.2.7	Periodic local authentication procedure	136
E.2.8	Radio link failure recovery	137
E.2.9	Avoiding key stream reuse caused by DRB type change	137
E.3	Dual connectivity architecture between a MeNB and a SgNB	137
E.3.1	Protection of the X2 reference point	137
E.3.2	Addition and modification of DRBs and/or SRB in SgNB	137
E.3.3	Activation of encryption/decryption of DRBs and encryption/decryption/integrity protection of SRB	138
E.3.4	Derivation of keys for RBs with PDCP in the SgNB	139
E.3.4.1	SCG Counter maintenance	139
E.3.4.2	Security key derivation	139

E.3.4.3	Negotiation of security algorithms.....	140
E.3.5	S-K _{gNB} update.....	141
E.3.5.1	S-K _{gNB} update triggers	141
E.3.5.2	S-K _{gNB} update procedure	141
E.3.6	Handover procedures.....	141
E.3.7	Periodic local authentication procedure	141
E.3.8	Radio link failure recovery	142
E.3.9	Avoiding key stream reuse caused by DRB type change	142
E.3.10	Protection of the traffic between the UE and SgNB.....	142
E.3.10.1	General.....	142
E.3.10.2	Creating the mapped UE NR security capabilities.....	142

Annex F (informative): Isolated E-UTRAN Operation for Public Safety.....143

F.1	General Description.....	143
F.2	IOPS security solution.....	143
F.3	Security Considerations.....	144
F.3.1	Malicious switching of USIM applications.....	144
F.3.2	Compromise of local HSSs	144
F.4	Mitigation of compromise of a local HSS.....	144
F.4.0	Introduction	144
F.4.1	'Subscriber key separation' mechanism	144
F.4.2	Key derivation mechanism for 'subscriber key separation'.....	145
F.5	Actions in case of compromise of a local HSS	146

Annex G (normative): LTE - WLAN aggregation147

G.1	Introduction	147
G.2	LTE-WLAN aggregation security.....	148
G.2.1	Protection of the WLAN Link between the UE and the WT.....	148
G.2.2	Protection of the Xw interface.....	148
G.2.3	Addition, modification and release of DRBs in LWA	148
G.2.4	Derivation of keys for the DRBs in LWA.....	149
G.2.4.1	WT Counter maintenance	149
G.2.4.2	Security key derivation	149
G.2.5	Security key update	149
G.2.5.1	Security key update triggers.....	149
G.2.5.2	Security key update procedures	150
G.2.6	Handover procedures.....	150
G.2.7	Periodic local authentication procedure	150
G.2.8	LTE and WLAN link failure	150
G.3	Method for installing PMK	150

Annex H (normative): LTE-WLAN RAN level integration using IPsec tunnelling153

H.1	General	153
H.2	Security of LTE-WLAN integration using IPsec Tunnelling.....	154
H.2.1	eNB to UE interaction for setting up the LWIP offload.....	154
H.2.2	UE to LWIP-SeGW interaction for setting up the LWIP offload.....	155
H.2.3	eNB to LWIP-SeGW interaction for setting the LWIP offload.....	155
H.3	Addition and modification of DRB in LTE-WLAN integration	156
H.4	Security Key for IKEv2 handshake.....	156
H.4.0	LWIP counter maintenance	156
H.4.1	Security Key (LWIP-PSK) Derivation	156
H.4.2	Security key (LWIP-PSK) update	156
H.5	Handover procedures.....	157
H.6	LWIP radio link failure	157

Annex I (normative):	Hash functions.....	158
I.1	General	158
I.2	HASH _{MME} and HASH _{UE}	158
I.3	Void.....	158
Annex J (normative):	Restricted Local Operator Services (RLOS).....	159
J.1	Restricted Local Operator Services (RLOS)	159
J.1.1	General.....	159
J.1.2	Algorithm negotiation for unauthenticated UEs in LSM	159
J.1.3	Additional UE behaviour for RLOS connections	159
J.2	Recommendations for RLOS	160
J.3	MCC whitelist for RLOS	160
Annex K (normative):	Security for Integrated Access and Backhaul (IAB) in EN-DC.....	161
K.1	General	161
K.2	IAB-node integration procedure.....	161
K.2.1	Authentication and Authorization of IAB-node	161
Annex L (informative):	Security Aspects of DNS and ICMP.....	163
L.1	General	163
Annex M (normative):	Protection of management traffic between IAB-node and OAM.....	164
Annex N (informative):	Change history	165
History		173

Foreword

This Technical Specification has been produced by the 3rd Generation Partnership Project (3GPP).

The contents of the present document are subject to continuing work within the TSG and may change following formal TSG approval. Should the TSG modify the contents of the present document, it will be re-released by the TSG with an identifying change of release date and an increase in version number as follows:

Version x.y.z

where:

- x the first digit:
 - 1 presented to TSG for information;
 - 2 presented to TSG for approval;
 - 3 or greater indicates TSG approved document under change control.
- y the second digit is incremented for all changes of substance, i.e. technical enhancements, corrections, updates, etc.
- z the third digit is incremented when editorial only changes have been incorporated in the document.

1 Scope

The present document specifies the security architecture, i.e., the security features and the security mechanisms for the Evolved Packet System and the Evolved Packet Core, and the security procedures performed within the evolved Packet System (EPS) including the Evolved Packet Core (EPC) and the Evolved UTRAN (E-UTRAN).

2 References

The following documents contain provisions which, through reference in this text, constitute provisions of the present document.

- References are either specific (identified by date of publication, edition number, version number, etc.) or non-specific.
- For a specific reference, subsequent revisions do not apply.
- For a non-specific reference, the latest version applies. In the case of a reference to a 3GPP document (including a GSM document), a non-specific reference implicitly refers to the latest version of that document *in the same Release as the present document*.

- [1] 3GPP TR 21.905: "Vocabulary for 3GPP Specifications".
- [2] 3GPP TS 23.401: "General Packet Radio Service (GPRS) enhancements for Evolved Universal Terrestrial Radio Access Network (E-UTRAN) access".
- [3] 3GPP TS 23.003: "Numbering, addressing and identification".
- [4] 3GPP TS 33.102: "3G security; Security architecture".
- [5] 3GPP TS 33.210: "3G security; Network Domain Security (NDS); IP network layer security".
- [6] 3GPP TS 33.310: "Network Domain Security (NDS); Authentication Framework (AF)".
- [7] IETF RFC 4303: "IP Encapsulating Security Payload (ESP)".
- [8] 3GPP TS 33.220: "Generic Authentication Architecture (GAA); Generic bootstrapping architecture".
- [9] 3GPP TS 24.301: "Non-Access-Stratum (NAS) protocol for Evolved Packet System (EPS); Stage 3".
- [10] – [11] Void.
- [12] 3GPP TS 36.323: "Evolved Universal Terrestrial Radio Access (E-UTRA); Packet Data Convergence Protocol (PDCP) specification"
- [13] 3GPP TS 31.102: "Characteristics of the Universal Subscriber Identity Module (USIM) application".
- [14] 3GPP TS 35.215: "Confidentiality and Integrity Algorithms UEA2 & UIA2; Document 1: UEA2 and UIA2 specifications"
- [15] NIST: "Advanced Encryption Standard (AES) (FIPS PUB 197) "
- [16] NIST Special Publication 800-38A (2001): "Recommendation for Block Cipher Modes of Operation".
- [17] NIST Special Publication 800-38B (2001): "Recommendation for Block Cipher Modes of Operation: The CMAC Mode for Authentication".
- [18] – [20] Void.

- [21] 3GPP TS 36.331: "Evolved Universal Terrestrial Radio Access (E-UTRA) Radio Resource Control (RRC); Protocol specification".
- [22] 3GPP TS 23.216: "Single Radio Voice Call Continuity (SRVCC); Stage 2".
- [23] 3GPP TS 22.101: "3rd Generation Partnership Project; Technical Specification Group Services and System Aspects; Service aspects; Service principles".
- [24] 3GPP TS 25.331: "3rd Generation Partnership Project; Technical Specification Group Radio Access Network; Radio Resource Control (RRC); Protocol Specification".
- [25] 3GPP TS 44.060: "3rd Generation Partnership Project; Technical Specification Group GSM/EDGE Radio Access Network; General Packet Radio Service (GPRS); Mobile Station (MS) - Base Station System (BSS) interface; Radio Link Control/Medium Access Control (RLC/MAC) protocol".
- [26] 3GPP TS 23.122: "3rd Generation Partnership Project; Technical Specification Group Core Network and Terminals; Non-Access-Stratum (NAS) functions related to Mobile Station (MS) in idle mode".
- [27] 3GPP TS 33.320: "3rd Generation Partnership Project; Technical Specification Group Services and System Aspects; Security of Home Node B (HNB) / Home evolved Node B (HeNB)".
- [28] (void)
- [29] ETSI TS 102 484 V10.0.0: "Smart Cards; Secure channel between a UICC and an end-point terminal".
- [30] 3GPP TS 36.300: "Evolved Universal Terrestrial Radio Access (E-UTRA) and Evolved Universal Terrestrial Radio Access Network (E-UTRAN); Overall description; Stage 2".
- [31] 3GPP TS 31.116 "Remote APDU Structure for (Universal) Subscriber Identity Module (U)SIM Toolkit applications".
- [32] ETSI TS 102 221 V9.2.0: "Smart Cards; UICC-Terminal interface; Physical and logical characteristics".
- [33] 3GPP TS 35.221: "Confidentiality and Integrity Algorithms EEA3 & EIA3; Document 1: EEA3 and EIA3 specifications".
- [34] RFC 4301: "Security Architecture for the Internet Protocol".
- [35] 3GPP TS 22.346: "Isolated Evolved Universal Terrestrial Radio Access Network (E-UTRAN) operation for public safety; Stage 1".
- [36] 3GPP TS 33.210: "3G security; Network Domain Security (NDS); IP network layer security".
- [37] 3GPP TS.33.310: "Network Domain Security (NDS); Authentication Framework (AF)".
- [38] IETF RFC 7296: " Internet Key Exchange Protocol Version 2 (IKEv2)".
- [39] IEEE 802.11, Part 11: "Wireless LAN Medium Access Control (MAC) and Physical Layer (PHY) specifications, IEEE Std.".
- [40] 3GPP TS 36.463: "Evolved Universal Terrestrial Radio Access Network (E-UTRAN) and Wireless LAN (WLAN); Xw application protocol (XwAP)".
- [41] 3GPP TS 33.402: "3GPP System Architecture Evolution (SAE); Security aspects of non-3GPP accesses".
- [42] 3GPP TS 36.413: "Evolved Universal Terrestrial Radio Access Network (E-UTRAN); S1 Application Protocol (S1AP)".
- [43] 3GPP TS 33.501: "Security architecture and procedures for 5G system".
- [44] 3GPP TS 38.300: "NR; Overall description; Stage-2".

- [45] 3GPP TS 36.423: "Evolved Universal Terrestrial Radio Access Network (E-UTRAN); X2 Application Protocol (X2AP)".

3 Definitions, symbols and abbreviations

3.1 Definitions

For the purposes of the present document, the terms and definitions given in TR 21.905 [1], in TS 33.102 [4] and the following apply. A term defined in the present document takes precedence over the definition of the same term, if any, in TR 21.905 [1].

Access Security Management Entity: entity which receives the top-level keys in an access network from the HSS. For E-UTRAN access networks, the role of the ASME is assumed by the MME

Activation of security context: the process of taking into use a security context.

Authentication data: Data that is part of a security context or of authentication vectors.

Chaining of K_{eNB} : derivation of a new K_{eNB} from another K_{eNB} (i.e., at cell handover)

Current EPS security context: The security context which has been activated most recently. Note that a current EPS security context originating from either a mapped or native EPS security context may exist simultaneously with a native non-current EPS security context.

ECM-CONNECTED state: This is as defined in TS 23.401 [2]. The term ECM-CONNECTED state corresponds to the term EMM-CONNECTED mode used in TS 24.301 [9].

ECM-IDLE state: As defined in TS 23.401 [2]. The term ECM-IDLE state corresponds to the term EMM-IDLE mode used in TS 24.301 [9].

EPS-Authentication Vector: K_{ASME} , RAND, AUTN, XRES

EPS security context: A state that is established locally at the UE and a serving network domain. At both ends "EPS security context data" is stored, that consists of the EPS NAS security context, and the EPS AS security context.

NOTE 1: An EPS security context has type "mapped", "full native" or "partial native". Its state can either be "current" or "non-current". A context can be of one type only and be in one state at a time. The state of a particular context type can change over time. A partial native context can be transformed into a full native. No other type transformations are possible.

EPS AS security context: the cryptographic keys at AS level with their identifiers, the Next Hop parameter NH, the Next Hop Chaining Counter parameter NCC used for next hop access key derivation, the identifiers of the selected AS level cryptographic algorithms, counters used for replay protection and SCG Counter used as freshness input into S- K_{eNB} derivations. Note that the EPS AS security context only exists when cryptographically protected radio bearers are established and is otherwise void.

NOTE 2: NH and NCC need to be stored also at the MME during connected mode.

EPS AS Secondary Cell security context: This context consists of the cryptographic keys for S_{eNB} (K_{UPenc}), the identifier of the selected AS SC level cryptographic algorithm and counters used for replay protection.

EPS NAS security context: This context consists of K_{ASME} with the associated key set identifier, the UE security capabilities, and the uplink and downlink NAS COUNT values. In particular, separate pairs of NAS COUNT values are used for each EPS NAS security contexts, respectively. The distinction between native and mapped EPS security contexts also applies to EPS NAS security contexts. The EPS NAS security context is called "full" if it additionally contains the keys K_{NASint} and K_{NASenc} and the identifiers of the selected NAS integrity and encryption algorithms.

Full native EPS security context: A native EPS security context for which the EPS NAS security context is full according to the above definition. A full native EPS security context is either in state "current" or state "non-current".

Forward security: In the context of K_{eNB} key derivation, forward security refers to the property that, for an eNB with knowledge of a K_{eNB} , shared with a UE, it shall be computationally infeasible to predict any future K_{eNB} , that will be used

between the same UE and another eNB. More specifically, n hop forward security refers to the property that an eNB is unable to compute keys that will be used between a UE and another eNB to which the UE is connected after n or more handovers (n=1 or 2).

IAB-node: As defined in TS 23.401 [2].

IAB-donor: As defined in TS 23.401 [2].

Legacy security context: A security context which has been established according to TS 33.102 [4].

Mapped security context: Security context created by converting the current security context in the source system to a security context for the target system in inter-system mobility, e.g., UMTS keys created from EPS keys. The EPS NAS security context of a mapped security context is full and current.

Native EPS security context: An EPS security context whose K_{ASME} was created by a run of EPS AKA.

Non-current EPS security context: A native EPS security context that is not the current one. A non-current EPS security context may be stored along with a current EPS security context in the UE and the MME. A non-current EPS security context does not contain an EPS AS security context. A non-current EPS security context is either of type "full native" or of type "partial native".

Partial native EPS security context: A partial native EPS security context consists of K_{ASME} with the associated key set identifier, the UE security capabilities, and the uplink and downlink NAS COUNT values, which are initially set to zero before the first NAS SMC procedure for this security context. A partial native EPS security context is created by an EPS AKA, for which no corresponding successful NAS SMC has been run. A partial native context is always in state "non-current".

Re-derivation of NAS keys: derivation of new NAS keys from the same K_{ASME} but including different algorithms (and no freshness parameter)

Refresh of K_{eNB} : derivation of a new K_{eNB} from the same K_{ASME} and including a freshness parameter

Re-keying of K_{eNB} : derivation of a new K_{eNB} from a new K_{ASME} in ECM-CONNECTED (i.e., . to activate a partial native EPS security context, or to re-activate a non-current full EPS security context)

Re-keying of NAS keys: derivation of new NAS keys from a new K_{ASME}

UE security capabilities: The set of identifiers corresponding to the ciphering and integrity algorithms implemented in the UE. This includes capabilities for EPS AS and NAS, and includes capabilities for UTRAN and GERAN if these access types are supported by the UE.

UE EPS security capabilities: The UE security capabilities for EPS AS and NAS.

User plane: Within the context of TS 33.401, this means the data path between UE and Serving Gateway that does NOT go via the MME.

(User) Data via MME: User Data sent to or from the UE that uses an RRC connection established using the Control Plane CIoT EPS optimisation specified in TS 23.401[2].

IOPS-capable eNB: an eNB that has the capability of IOPS mode operation, which provides local IP connectivity and Public Safety services to IOPS-enabled UEs via a Local EPC when the eNB has lost backhaul to the Macro EPC or it has no backhaul to the Macro EPC.

IOPS network: an IOPS network consists of one or more eNBs operating in IOPS mode and connected to a Local EPC.

Local EPC: a Local EPC is an entity which provides functionality that eNBs in IOPS mode of operation use, instead of the Macro EPC, in order to support Public Safety services.

Macro EPC: the EPC which serves an eNB when it is not in IOPS mode of operation.

Nomadic EPS: a deployable system which has the capability to provide radio access (via deployable IOPS-capable eNB(s)), local IP connectivity and Public Safety services to IOPS-enabled UEs in the absence of normal EPS.**IOPS-enabled UE:** is an UE that is configured to use networks operating in IOPS mode.

3.2 Symbols

For the purposes of the present document, the following symbols apply:

	Concatenation
⊕	Bitwise Exclusive Or (XOR) operation

3.3 Abbreviations

For the purposes of the present document, the abbreviations given in TR 21.905 [1] and the following apply. An abbreviation defined in the present document takes precedence over the definition of the same abbreviation, if any, in TR 21.905 [1].

AES	Advanced Encryption Standard
AK	Anonymity Key
AKA	Authentication and Key Agreement
AMF	Authentication Management Field
AN	Access Network
AS	Access Stratum
AUTN	Authentication token
AV	Authentication Vector
ASME	Access Security Management Entity
Cell-ID	Cell Identity as used in TS 36.331 [21]
CHO	Conditional Handover
CK	Cipher Key
CKSN	Cipher Key Sequence Number
C-RNTI	Cell RNTI as used in TS 36.331 [21]
CRL	Certificate Revocation List
DeNB	Donor eNB
DoS	Denial of Service
DSCP	Differentiated Services Code Point
EARFCN-DL	E-UTRA Absolute Radio Frequency Channel Number-Down Link
ECM	EPS Connection Management
EDT	Early Data Transmission
EEA	EPS Encryption Algorithm
EIA	EPS Integrity Algorithm
eKSI	Key Set Identifier in E-UTRAN
EMM	EPS Mobility Management
eNB	Evolved Node-B
EPC	Evolved Packet Core
EPS	Evolved Packet System
EPS-AV	EPS authentication vector
E-UTRAN	Evolved UTRAN
gNB	Next Generation Node-B
GERAN	GSM EDGE Radio Access Network
GUTI	Globally Unique Temporary Identity
HE	Home Environment
HFN	Hyper Frame Number
HO	Hand Over
HSS	Home Subscriber Server
IAB	Integrated Access and Backhaul
IK	Integrity Key
IKE	Internet Key Exchange
IMEI	International Mobile Station Equipment Identity
IMEISV	International Mobile Station Equipment Identity and Software Version number
IMSI	International Mobile Subscriber Identity
IOPS	Isolated E-UTRAN Operation for Public Safety
IRAT	Inter-Radio Access Technology
ISR	Idle Mode Signaling Reduction
KDF	Key Derivation Function

KSI	Key Set Identifier
LWIP	LTE WLAN RAN Level Integration using IPSec
LSB	Least Significant Bit
LSM	Limited Service Mode
LWA	LTE-WLAN Aggregation
MAC-I	Message Authentication Code for Integrity (terminology of TS36.323 [12])
MACT	Message Authentication Code T used in AES CMAC calculation
MeNB	Master eNB
ME	Mobile Equipment
MME	Mobility Management Entity
MME-RN	MME serving the RN
MS	Mobile Station
MSC	Mobile Switching Center
MSIN	Mobile Station Identification Number
NAS	Non Access Stratum
NAS-MAC	Message Authentication Code for NAS for Integrity (called MAC in TS24.301 [9])
NASDVM	Non Access Stratum - Data via MME
NCC	Next hop Chaining Counter
NH	Next Hop
OCSP	Online Certificate Status Protocol
OTA	Over-The-Air (update of UICCs)
PCI	Physical Cell Identity as used in TS 36.331 [21]
PDCP	Packet Data Convergence Protocol
PLMN	Public Land Mobile Network
PRNG	Pseudo Random Number Generator
PSK	Pre-shared Key
P-TMSI	Packet- Temporary Mobile Subscriber Identity
RAND	RANdOm number
RAU	Routing Area Update
RLOS	Restricted Local Operator Services
RN	Relay Node
RRC	Radio Resource Control
SCG	Secondary Cell Group
SEG	Security Gateway
SGSN	Serving GPRS Support Node
SIM	Subscriber Identity Module
SMC	Security Mode Command
SeNB	Secondary eNB
SgNB	Secondary gNB
SN	Serving Network
SN id	Serving Network identity
SQN	Sequence Number
SRB	Source Route Bridge
SRVCC	Single Radio Voice Call Continuity
S-TMSI	S-Temporary Mobile Subscriber Identity
TAI	Tracking Area Identity
TAU	Tracking Area Update
UE	User Equipment
UEA	UMTS Encryption Algorithm
UIA	UMTS Integrity Algorithm
UICC	Universal Integrated Circuit Card
UMTS	Universal Mobile Telecommunication System
UP	User Plane
USIM	Universal Subscriber Identity Module
UTRAN	Universal Terrestrial Radio Access Network
WT	WLAN Termination as used in TS 36.300 [30]
XRES	Expected Response

3.4 Conventions

All data variables in the present document are presented with the most significant substring on the left hand side and the least significant substring on the right hand side. A substring may be a bit, byte or other arbitrary length bitstring.

Where a variable is broken down into a number of substrings, the leftmost (most significant) substring is numbered 0, the next most significant is numbered 1, and so on through to the least significant.

4 Overview of Security Architecture

Figure 4-1 gives an overview of the complete security architecture.

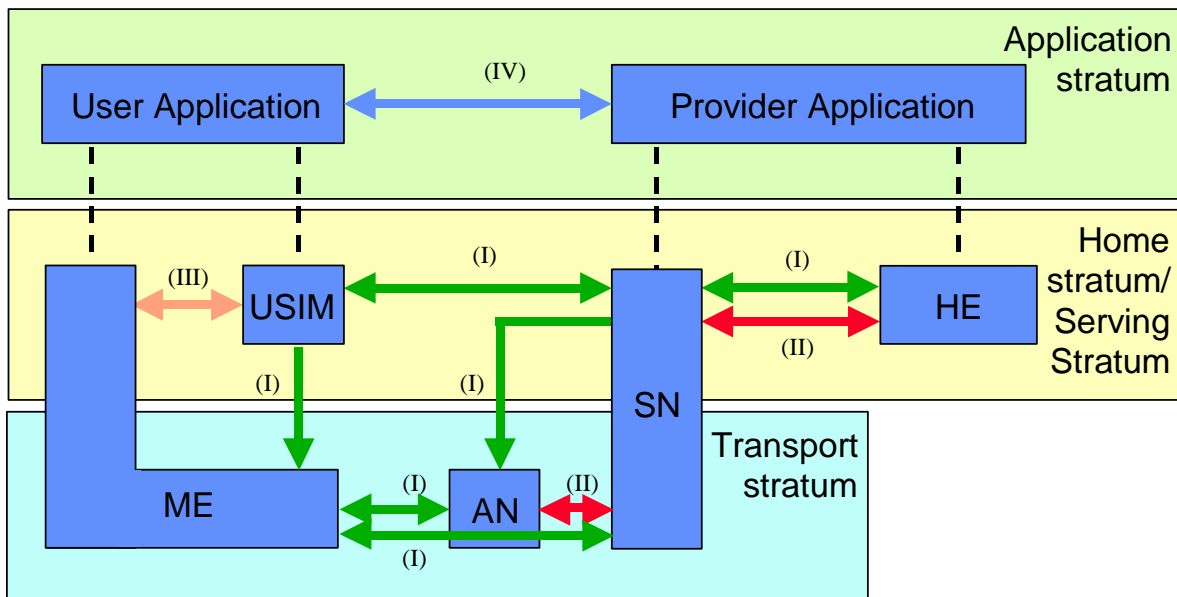

Figure 4-1: Overview of the security architecture

Five security feature groups are defined. Each of these feature groups meets certain threats and accomplishes certain security objectives:

- **Network access security (I):** the set of security features that provide users with secure access to services, and which in particular protect against attacks on the (radio) access link.
- **Network domain security (II):** the set of security features that enable nodes to securely exchange signalling data, user data (between AN and SN and within AN), and protect against attacks on the wireline network.
- **User domain security (III):** the set of security features that secure access to mobile stations.
- **Application domain security (IV):** the set of security features that enable applications in the user and in the provider domain to securely exchange messages.
- **Visibility and configurability of security (V):** the set of features that enables the user to inform himself whether a security feature is in operation or not and whether the use and provision of services should depend on the security feature.

NOTE 1: Relay nodes are not explicitly shown in Figure 4-1. They combine the functionalities of ME and AN in a way described in 3GPP TS 36.300 [30]. The present document describes how to apply security features to relay nodes.

NOTE 2: There is an option for some uplink and downlink user data to be sent via the MME. This is referred to as "data via MME" and within the context of TS 33.401 the abbreviation NASDVM is used.

5 Security Features

5.1 User-to-Network security

5.1.0 General

The statements relating to eNBs in clause 5.1 apply also to RNs regarding the security between a UE and a relay node.

The statements relating to UEs in clause 5.1 apply also to RNs regarding the security between a relay node and a Donor eNB and between a relay node and its MME unless stated otherwise.

5.1.1 User identity and device confidentiality

User identity confidentiality is as defined by TS 33.102 [4] subclause 5.1.1

From subscriber's privacy point of view, the MSIN, the IMEI, and the IMEISV should be confidentiality protected.

The UE shall provide its equipment identifier IMEI or IMEISV to the network, if the network asks for it in an integrity-protected request.

The IMEI and IMEISV shall be securely stored in the terminal.

The UE shall not send IMEI or IMEISV to the network on a network request before the NAS security has been activated.

NOTE 1: When the UE has no IMSI, no valid GUTI, or no valid P-TMSI during emergency attach, the IMEI is included before the NAS security has been activated.

The IMEI or IMEISV shall be sent in the NAS protocol.

NOTE 2: In some cases, e.g., the very first attach procedure, MSIN has to be sent to network in cleartext. When NAS confidentiality protection is beyond an operator option, IMEI and IMEISV can not be confidentiality protected.

5.1.2 Entity authentication

Entity authentication is as defined by TS 33.102 [4] subclause 5.1.2

5.1.3 User data and signalling data confidentiality

5.1.3.1 Ciphering requirements

Ciphering may be provided to RRC-signalling to prevent UE tracking based on cell level measurement reports, handover message mapping, or cell level identity chaining. RRC signalling confidentiality is an operator option.

All S1 and X2 messages carried between RN and DeNB shall be confidentiality-protected.

NOTE 0: Encryption is subject to national regulation.

Synchronization of the input parameters for ciphering shall be ensured for the protocols involved in the ciphering.

The NAS signalling may be confidentiality protected. NAS signalling confidentiality is an operator option.

NOTE 1: RRC and NAS signalling confidentiality protection is recommended to be used.

When authentication of the credentials on the UICC during Emergency Calling in Limited Service Mode, as defined in the TS 23.401 [2], can not be successfully performed, the confidentiality protection of the RRC and NAS signaling, and user plane shall be omitted (see clause 15). This shall be accomplished by the network by selecting EEA0 for confidentiality protection of NAS, RRC and user plane.

User plane confidentiality protection over the access stratum shall be done at PDCP layer and is an operator option.

NOTE 2: User plane confidentiality protection is recommended to be used.

NOTE 3: Confidentiality protection for RRC and UP is applied at the PDCP layer, and no layers below PDCP are confidentiality protected. Confidentiality protection for NAS is provided by the NAS protocol.

User data sent via MME may be confidentiality protected

NOTE 4: Confidentiality protection of user data sent via MME is recommended to be used.

5.1.3.2 Algorithm Identifier Values

All algorithms specified in this subclause are algorithms with a 128-bit input key except Null ciphering algorithm.

NOTE: Deviations from the above requirement have to be indicated explicitly in the algorithm identifier list below.

Each EPS Encryption Algorithm (EEA) will be assigned a 4-bit identifier. Currently, the following values have been defined for NAS, RRC and UP ciphering:

"0000 ₂ "	EEA0	Null ciphering algorithm
"0001 ₂ "	128-EEA1	SNOW 3G based algorithm
"0010 ₂ "	128-EEA2	AES based algorithm
"0011 ₂ "	128-EEA3	ZUC based algorithm

The remaining values have been reserved for future use.

UEs and eNBs shall implement EEA0, 128-EEA1 and 128-EEA2 for both RRC signalling ciphering and UP ciphering. UEs and eNBs may implement 128-EEA3 for both RRC signalling ciphering and UP ciphering.

UEs and MMEs shall implement EEA0, 128-EEA1 and 128-EEA2 for NAS signalling ciphering. UEs and MMEs may implement 128-EEA3 for NAS signalling ciphering.

5.1.4 User data and signalling data integrity

5.1.4.1 Integrity requirements

Synchronization of the input parameters for integrity protection shall be ensured for the protocols involved in the integrity protection.

Integrity protection, and replay protection, shall be provided to NAS and RRC-signalling.

All NAS signaling messages except those explicitly listed in TS 24.301 [9] as exceptions shall be integrity-protected. All RRC signaling messages except those explicitly listed in TS 36.331 [21] as exceptions shall be integrity-protected.

When authentication of the credentials on the UICC during Emergency Calling in Limited Service Mode, as defined in the TS 23.401 [2], can not be successfully performed, the integrity and replay protection of the RRC and NAS signaling shall be omitted (see clause 15). This shall be accomplished by the network by selecting EIA0 for integrity protection of NAS and RRC. EIA0 shall only be used for unauthenticated emergency calls.

User plane packets between the eNB and the UE shall not be integrity protected on the Uu interface. User plane packets between the RN and the UE shall not be integrity protected. All user plane packets carrying S1 and X2 messages between RN and DeNB shall be integrity-protected. Integrity protection for all other user plane packets between RN and DeNB may be supported.

All user data packets sent via the MME shall be integrity protected.

5.1.4.2 Algorithm Identifier Values

All algorithms specified in this subclause are algorithms with a 128-bit input key.

NOTE: Deviations from the above requirement have to be indicated explicitly in the algorithm identifier list below.

Each EPS Integrity Algorithm (EIA) will be assigned a 4-bit identifier. Currently, the following values have been defined:

"0000 ₂ "	EIA0	Null Integrity Protection algorithm
"0001 ₂ "	128-EIA1	SNOW 3G based algorithm
"0010 ₂ "	128-EIA2	AES based algorithm
"0011 ₂ "	128-EIA3	ZUC based algorithm

The remaining values have been reserved for future use.

UEs and eNBs shall implement 128-EIA1 and 128-EIA2 for RRC signalling integrity protection. UEs and eNBs may implement 128-EIA3 for RRC signalling integrity protection.

UEs and MMEs shall implement 128-EIA1 and 128-EIA2 for NAS signalling integrity protection. UEs and MMEs may implement 128-EIA3 for NAS signalling integrity protection.

UEs shall implement EIA0 for integrity protection of NAS and RRC signalling. As specified in clause 5.1.4.1 of this specification, EIA0 is only allowed for unauthenticated emergency calls. EIA0 shall not be used for integrity protection between RN and DeNB.

Implementation of EIA0 in MMEs, RNs and eNBs is optional, EIA0, if implemented, shall be disabled in MMEs, RNs and eNBs in the deployments where support of unauthenticated emergency calling is not a regulatory requirement.

5.2 Security visibility and configurability

Although in general the security features should be transparent to the user, for certain events and according to the user's concern, greater user visibility of the operation of following security feature shall be provided:

- indication of access network encryption: the property that the user is informed whether the confidentiality of user data is protected on the radio access link, in particular when non-ciphered calls are set-up;

The ciphering indicator feature is specified in 3GPP TS 22.101 [23].

Configurability is the property that the user can configure whether the use or the provision of a service should depend on whether a security feature is in operation. A service can only be used if all security features, which are relevant to that service and which are required by the configurations of the user, are in operation. The following configurability features are suggested:

- enabling/disabling user-USIM authentication: the user should be able to control the operation of user-USIM authentication, e.g., for some events, services or use.

5.3 Security requirements on eNodeB

5.3.1 General

The security requirements given in this section apply to all types of eNodeBs. More stringent requirements for specific types of eNodeBs may be defined in other 3GPP specifications.

5.3.2 Requirements for eNB setup and configuration

Setting up and configuring eNBs shall be authenticated and authorized so that attackers shall not be able to modify the eNB settings and software configurations via local or remote access.

1. The support of security associations is required between the Evolved Packet Core (EPC) and the eNB and between adjacent eNBs, connected via X2. These security association establishments shall be mutually authenticated and used for user and control plane communication between the entities. However, in cases when a DeNB acts as proxy for control or user plane messages to and from a RN, hop-by-hop security associations shall be used for user and control plane. The security associations shall be realized according to clauses 11 and 12 of the present document except for the Un interface between RN and DeNB. The decision on whether or not to use the certificate enrolment mechanism specified in TS 33.310 [6] for eNB is left to operators.
2. Communication between the O&M systems and the eNB shall be confidentiality, integrity and replay protected from unauthorized parties. The support of security associations is required between the eNB and an entity in the Evolved Packet Core (EPC) or in an O&M domain trusted by the operator. These security association establishments shall be mutually authenticated. The security associations shall be realized according to clause 13 for eNBs and clause D.2.5 for RNs.
3. The eNB shall be able to ensure that software/data change attempts are authorized
4. The eNB shall use authorized data/software.
5. Sensitive parts of the boot-up process shall be executed with the help of the secure environment.
6. Confidentiality of software transfer towards the eNB shall be ensured.
7. Integrity protection of software transfer towards the eNB shall be ensured.

5.3.3 Requirements for key management inside eNB

The EPC provides subscriber specific session keying material for the eNBs, which also hold long term keys used for authentication and security association setup purposes. Protecting all these keys is important.

1. Keys stored inside eNBs shall never leave a secure environment within the eNB except when done in accordance with this or other 3GPP specifications.

5.3.4 Requirements for handling User plane data for the eNB

It is eNB's task to cipher and decipher user plane packets between the Uu reference point and the S1/X2 reference points and to handle integrity protection for user plane packets for the S1/X2 reference points.

1. User plane data ciphering/deciphering and integrity handling shall take place inside the secure environment where the related keys are stored.
2. The transport of user data over S1-U and X2-U shall be integrity, confidentiality and replay-protected from unauthorized parties. If this is to be accomplished by cryptographic means, clause 12 shall be applied except for the Un interface between RN and DeNB.

NOTE: The use of cryptographic protection on S1-U and X2-U is an operator's decision. In case the eNB has been placed in a physically secured environment then the 'secure environment' may include other nodes and links beside the eNB.

5.3.4a Requirements for handling Control plane data for the eNB

It is eNB's task to provide confidentiality and integrity protection for control plane packets on the S1/X2 reference points.

1. Control plane data ciphering/deciphering and integrity handling shall take place inside the secure environment where the related keys are stored.
2. The transport of control plane data over S1-MME and X2-C shall be integrity-, confidentiality- and replay-protected from unauthorized parties. If this is to be accomplished by cryptographic means, clause 11 shall be applied except for the Un interface between RN and DeNB.

NOTE: The use of cryptographic protection on S1-MME and X2-C is an operator's decision. In case the eNB has been placed in a physically secured environment then the 'secure environment' may include other nodes and links beside the eNB.

5.3.5 Requirements for secure environment of the eNB

The secure environment is logically defined within the eNB and is a composition of functions for the support of sensitive operations.

1. The secure environment shall support secure storage of sensitive data, e.g. long term cryptographic secrets and vital configuration data.
2. The secure environment shall support the execution of sensitive functions, e.g. en-/decryption of user data and the basic steps within protocols which use long term secrets (e.g. in authentication protocols).
3. Sensitive data used within the secure environment shall not be exposed to external entities.
4. The secure environment shall support the execution of sensitive parts of the boot process.
5. The secure environment's integrity shall be assured.
6. Only authorised access shall be granted to the secure environment, i.e. to data stored and used within, and to functions executed within.

5.4 Void

6 Security Procedures between UE and EPC Network Elements

6.0 General

The statements relating to eNBs in clause 6 apply also to RNs regarding the security between a UE and a relay node.

The statements relating to UEs and MEs in clause 6 apply also to RNs regarding the security between a relay node and a Donor eNB and between a relay node and its MME unless stated otherwise.

6.1 Authentication and key agreement

6.1.1 AKA procedure

NOTE 1: Authentication data in this subclause stands for EPS Authentication vector(s).

EPS AKA is the authentication and key agreement procedure that shall be used over E-UTRAN.

A Rel-99 or later USIM application on a UICC shall be sufficient for accessing E-UTRAN, provided the USIM application does not make use of the separation bit of the AMF in a way described in TS 33.102 [4] Annex F. Access to E-UTRAN with a 2G SIM or a SIM application on a UICC shall not be granted.

An ME that has E-UTRAN radio capability shall support the USIM-ME interface as specified in TS 31.102 [13]

EPS AKA shall produce keying material forming a basis for user plane (UP), RRC, and NAS ciphering keys as well as RRC and NAS integrity protection keys.

NOTE 2: Key derivation requirements of AS and NAS keys can be found in subclause 7.2.1.

The MME sends to the USIM via ME the random challenge RAND and an authentication token AUTN for network authentication from the selected authentication vector. It also includes a KSI_{ASME} for the ME which will be used to identify the K_{ASME} (and further keys derived from the K_{ASME}) that results from the EPS AKA procedure.

At receipt of this message, the USIM shall verify the freshness of the authentication vector by checking whether AUTN can be accepted as described in TS 33.102[4]. If so, the USIM computes a response RES. USIM shall compute CK and IK which are sent to the ME. If the USIM computes a Kc (i.e. GPRS Kc) from CK and IK using conversion function c3

as described in TS 33.102 [4], and sends it to the ME, then the ME shall ignore such GPRS Kc and not store the GPRS Kc on USIM or in ME. If the verification fails, the USIM indicates to the ME the reason for failure and in the case of a synchronisation failure passes the AUTS parameter (see TS 33.102 [4]).

An ME accessing E-UTRAN shall check during authentication that the "separation bit" in the AMF field of AUTN is set to 1. The "separation bit" is bit 0 of the AMF field of AUTN.

NOTE 3: This separation bit in the AMF can not be used anymore for operator specific purposes as described by TS 33.102 [4], Annex F.

NOTE 4: If the keys CK, IK resulting from an EPS AKA run were stored in the fields already available on the USIM for storing keys CK and IK this could lead to overwriting keys resulting from an earlier run of UMTS AKA. This would lead to problems when EPS security context and UMTS security context were held simultaneously (as is the case when security context is stored e.g. for the purposes of Idle Mode Signaling Reduction). Therefore, "plastic roaming" where a UICC is inserted into another ME will necessitate an EPS AKA authentication run if the USIM does not support EMM parameters storage.

UE shall respond with User authentication response message including RES in case of successful AUTN verification and successful AMF verification as described above. In this case the ME shall compute K_{ASME} from CK, IK, and serving network's identity (SN id) using the KDF as specified in clause A.2. SN id binding implicitly authenticates the serving network's identity when the derived keys from K_{ASME} are successfully used.

NOTE 5: This does not preclude a USIM (see TS 31.102 [13]) in later releases having the capability of deriving K_{ASME} .

Otherwise UE shall send an authentication failure message with a CAUSE value indicating the reason for failure. In case of a synchronisation failure of AUTN (as described in TS 33.102 [4]), the UE also includes AUTS that was provided by the USIM. Upon receipt of an authentication failure message, the MME may initiate further identity requests and authentications towards the UE. (see TS 24.301 [9]).

The MME checks that the RES equals XRES. If so the authentication is successful. If not, depending on type of identity used by the UE in the initial NAS message, the MME may initiate further identity requests or send an authentication reject message towards the UE (see TS 24.301 [9]).

Figure 6.1.1-1 describes EPS AKA procedure, which is based on UMTS AKA (see TS 33.102[4]). The following keys are shared between UE and HSS:

- **K** is the permanent key stored on the USIM on a UICC and in the Authentication Centre AuC.
- **CK, IK** is the pair of keys derived in the AuC and on the USIM during an AKA run. CK, IK shall be handled differently depending on whether they are used in an EPS security context or a legacy security context, as described in subclause 6.1.2.

As a result of the authentication and key agreement, an intermediate key K_{ASME} shall be shared between UE and MME i.e. the ASME for EPS.

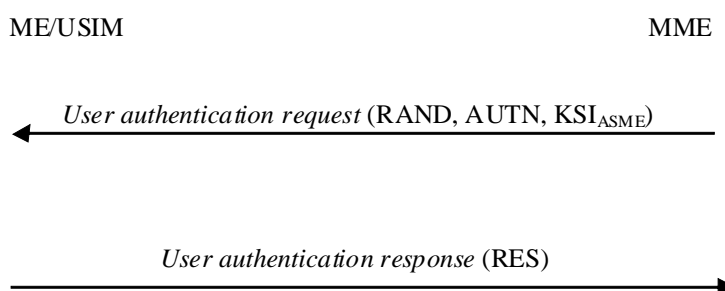

Figure 6.1.1-1: Successful EPS AKA authentication

6.1.2 Distribution of authentication data from HSS to serving network

NOTE 1: Authentication data in this subclause stands for EPS Authentication vector(s).

The purpose of this procedure is to provide the MME with one or more EPS authentication vectors (RAND, AUTN, XRES, K_{ASME}) from the user's HE (HSS) to perform user authentication. Each EPS authentication vector can be used to authenticate the UE.

NOTE 2: It is recommended that the MME fetch only one EPS authentication vector at a time as the need to perform AKA runs has been reduced in EPS through the use of a more elaborate key hierarchy. In particular, service requests can be authenticated using a stored K_{ASME} without the need to perform AKA. Furthermore, the sequence number management schemes in TS 33.102, Annex C [4], designed to avoid re-synchronisation problems caused by interleaving use of batches of authentication vectors, are only optional. Re-synchronisation problems in EPS can be avoided, independently of the sequence number management scheme, by immediately using an authentication vector retrieved from the HSS in an authentication procedure between UE and MME.

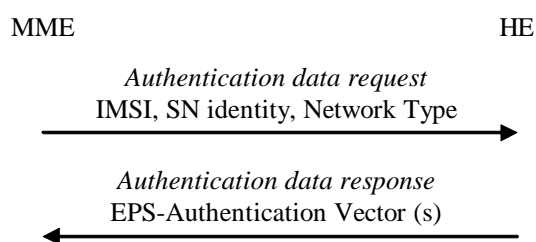

Figure 6.1.2-1: Distribution of authentication data from HE to MME

An EPS authentication vector is derived from the authentication vector defined in TS 33.102 [4] clause 6.3.2. To derive the key K_{ASME} in the HE, the KDF as specified in clause A.2 is used which shall contain following mandatory input parameters: CK, IK and SN identity.

If the Network Type equals E-UTRAN then the "separation bit" in the AMF field of AUTN shall be set to 1 to indicate to the UE that the authentication vector is only usable for AKA in an EPS context, if the "separation bit" is set to 0, the vector is usable in a non-EPS context only (e.g. GSM, UMTS). For authentication vectors with the "separation bit" set to 1, the secret keys CK and IK generated during AKA shall never leave the HSS.

The MME invokes the procedures by requesting authentication vectors from the HE (Home environment).

The *authentication data request* shall include the IMSI, the Serving Network identity i.e. MCC + MNC, and the Network Type (i.e. E-UTRAN). In the case of a synchronisation failure, the MME shall also include RAND and AUTS. In this case the HE checks the AUTS parameter before sending new authentication vectors to the MME (see TS 33.102 [4]).

Upon the receipt of the *authentication data request* from the MME, the HE may have pre-computed the required number of EPS authentication vectors and retrieve them from the HSS database or may compute them on demand.

NOTE 3: For K_{ASME} the possibilities for pre-computation are restricted due to the PLMN-binding.

NOTE 4: The HSS needs to ensure that the MME requesting the authentication data is entitled to use the SN id used to calculate K_{ASME} . The exact details of how to achieve this are not covered in this specification.

The HE sends an authentication response back to the MME that contains the requested information. If multiple EPS authentication vectors had been requested then they are ordered based on their sequence numbers. The MME shall be aware of the order of the EPS authentication vectors and shall use that the EPS authentication vectors in order.

6.1.3 User identification by a permanent identity

The user identification mechanism should be invoked by the serving network whenever the user cannot be identified by means of a temporary identity (GUTI). In particular, it should be used when the serving network cannot retrieve the IMSI based on the GUTI by which the user identifies itself on the radio path.

The mechanism described in figure 6.1.3-1 allows the identification of a user on the radio path by means of the permanent subscriber identity (IMSI).

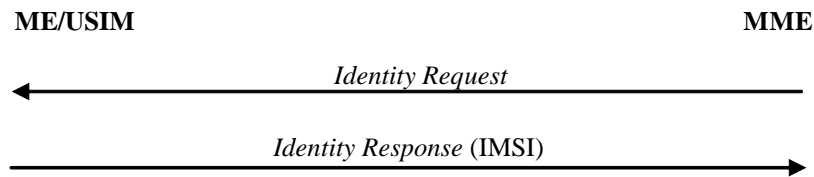

Figure 6.1.3-1: User identity query

The mechanism is initiated by the MME that requests the user to send its permanent identity. The user's response contains the IMSI in cleartext. This represents a breach in the provision of user identity confidentiality.

6.1.4 Distribution of IMSI and authentication data within one serving network domain

NOTE 1: Authentication data in this subclause stands for EPS security contexts and EPS authentication vector(s).

The purpose of this procedure is to provide a newly visited MME with authentication data from a previously visited MME within the same serving network domain.

NOTE 2: The following procedure in this clause is based on TAU procedure and it can also be applied for Attach procedure where all the corresponding texts for "TAU" in the following procedure should be replaced with "Attach".

The procedure is shown in Figure 6.1.4-1

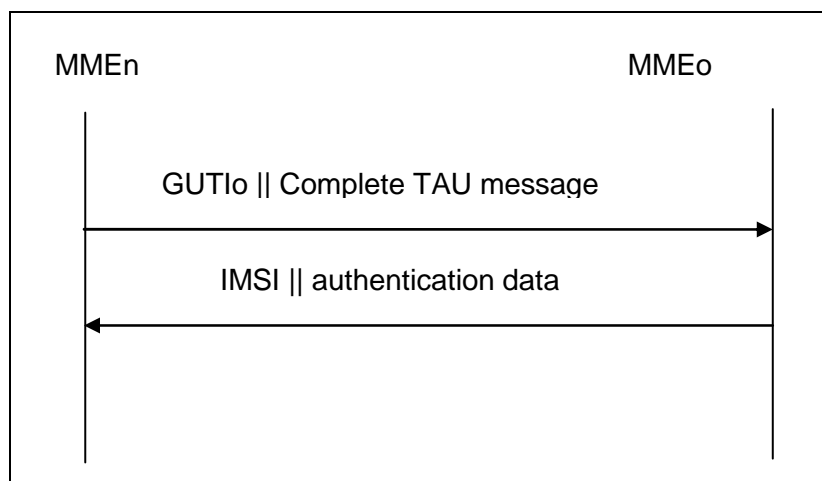

Figure 6.1.4-1: Distribution of IMSI and authentication data within one serving domain

The procedure shall be invoked by the newly visited MMEn after the receipt of a Tracking Area update request from the user wherein the user is identified by means of a temporary user identity GUTIo and the Tracking area identity TAIo under the jurisdiction of a previously visited MMEo that belongs to the same serving network domain as the newly visited MMEn.

The protocol steps are as follows:

- a) The MMEn sends a message to the MMEo, this message contains GUTIo and the received TAU message.
- b) The MMEo searches the user data in the database and checks the integrity protection on the TAU message.

If the user is found and the integrity check succeeds, the MMEo shall send a response back that:

- i) shall include the IMSI,

- ii) may include a number of unused EPS-authentication vectors ordered on a first-in / first-out basis, and
- iii) may include any EPS security contexts it holds

The MMEo subsequently deletes the EPS-authentication vectors and any EPS security contexts which have been sent.

If the user cannot be identified or the integrity check fails, then the MMEo shall send a response indicating that the user identity cannot be retrieved.

- c) If the MMEn receives a response with an IMSI, it creates an entry and stores any EPS-authentication vectors and any EPS security context that may be included.

If the MMEn receives a response indicating that the user could not be identified, it shall initiate the user identification procedure described in clause 6.1.3 during the Initial E-UTRAN Attach procedure, or it shall reject the TAU Request message initiated by UE during the TAU procedure (see clause 4.4.4.3 in TS24.301[9]).

The same procedure does not apply to distribution of EPS authentication data between MME and SGSN in the same serving network domain, i.e. EPS authentication data shall not be forwarded from an MME towards an SGSN.

NOTE 3: This is due to the fact that EPS authentication data does not contain CK and IK and, hence, is not useful for the SGSN.

6.1.5 Distribution of IMSI and authentication data between different serving network domains

NOTE 1: Authentication data in this subclause stands for EPS security contexts and EPS authentication vector(s).

In general, the distribution of IMSI and authentication data between MMEs belonging to different serving network domains shall be performed as described for the distribution of IMSI and authentication data within the same service network domain in subclause 6.1.4. In particular, the current EPS security context data may be transferred between MMEs belonging to different serving network domains. However, there is the following restriction:

- Unused EPS authentication vectors, or non-current EPS security contexts, shall not be distributed between MMEs belonging to different serving domains (PLMNs).

The same procedure does not apply to distribution of EPS authentication data between MME and SGSN in different serving network domains, i.e. EPS authentication data shall not be forwarded from an MME towards an SGSN.

NOTE 2: This is due to the fact that EPS authentication data does not contain CK and IK and, hence, is not useful for the SGSN.

6.1.6 Distribution of IMSI and UMTS authentication vectors between MMEs or between MME and SGSN

This subclause applies to both distribution of UMTS authentication vectors within one serving network domain and distribution of UMTS authentication vectors between different serving network domains. The following rules apply to the distribution of UMTS authentication vectors between two MMEs, and between an SGSN and an MME:

- a) MME to MME

UMTS authentication vectors that were previously received from an SGSN shall not be forwarded between MME's.

- b) SGSN to MME

An SGSN may forward unused UMTS authentication vectors to an MME, only if MME and SGSN are in the same serving network domain.

- c) MME to SGSN

UMTS AVs which were previously stored in the MME may be forwarded back towards the same SGSN.

UMTS AVs which were previously stored in the MME shall not be forwarded towards other SGSNs.

6.2 EPS key hierarchy

Requirements on EPC and E-UTRAN related to keys:

- The EPC and E-UTRAN shall allow for use of encryption and integrity protection algorithms for AS and NAS protection having keys of length 128 bits and for future use the network interfaces shall be prepared to support 256 bit keys.
- The keys used for UP, NAS and AS protection shall be dependent on the algorithm with which they are used.

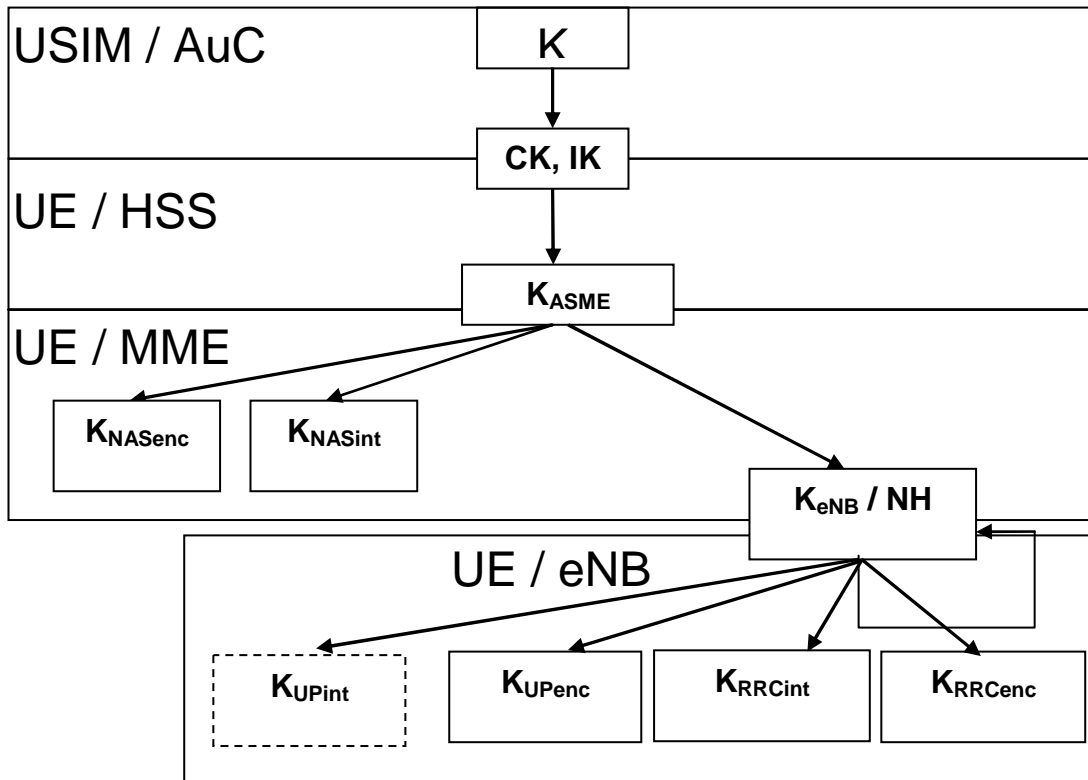

Figure 6.2-1: Key hierarchy in E-UTRAN

The key hierarchy (see Figure 6.2-1) includes following keys: K_{eNB} , K_{NASint} , K_{NASenc} , K_{UPenc} , K_{RRCint} , K_{RRCenc} and K_{UPint}

- K_{eNB} is a key derived by ME and MME from K_{ASME} or by ME and target eNB.

Keys for NAS traffic:

- K_{NASint} is a key, which shall only be used for the protection of NAS traffic with a particular integrity algorithm. This key is derived by ME and MME from K_{ASME} , as well as an identifier for the integrity algorithm using the KDF as specified in clause A.7.
- K_{NASenc} is a key, which shall only be used for the protection of NAS traffic with a particular encryption algorithm. This key is derived by ME and MME from K_{ASME} , as well as an identifier for the encryption algorithm using the KDF as specified in clause A.7.

Keys for UP traffic:

- K_{UPenc} is a key, which shall only be used for the protection of UP traffic with a particular encryption algorithm. This key is derived by ME and eNB from K_{eNB} , as well as an identifier for the encryption algorithm using the KDF as specified in clause A.7.
- K_{UPint} is a key, which shall only be used for the protection of UP traffic between RN and DeNB with a particular integrity algorithm. This key is derived by RN and DeNB from K_{eNB} , as well as an identifier for the integrity algorithm using the KDF as specified in clause A.7.

Keys for RRC traffic:

- K_{RRCint} is a key, which shall only be used for the protection of RRC traffic with a particular integrity algorithm. K_{RRCint} is derived by ME and eNB from K_{eNB} , as well as an identifier for the integrity algorithm using the KDF as specified in clause A.7.
- K_{RRCenc} is a key, which shall only be used for the protection of RRC traffic with a particular encryption algorithm. K_{RRCenc} is derived by ME and eNB from K_{eNB} as well as an identifier for the encryption algorithm using the KDF as specified in clause A.7.

Intermediate keys:

- NH is a key derived by ME and MME to provide forward security as described in clause 7.2.8.
- K_{eNB}^* is a key derived by ME and eNB when performing an horizontal or vertical key derivation as specified in clause 7.2.8 using a KDF as specified in clause A5.

Figure 6.2-2 shows the dependencies between the different keys, and how they are derived from the network nodes point of view. Figure 6.2-3 shows the corresponding relations and derivations as performed in the ME. Two dashed inputs to a KDF means one of the inputs is used depending on the circumstances of the key derivation.

NOTE: Figures 6.2-2 and 6.2-3 do not cover the derivations at IRAT mobility (see clauses 9 and 10).

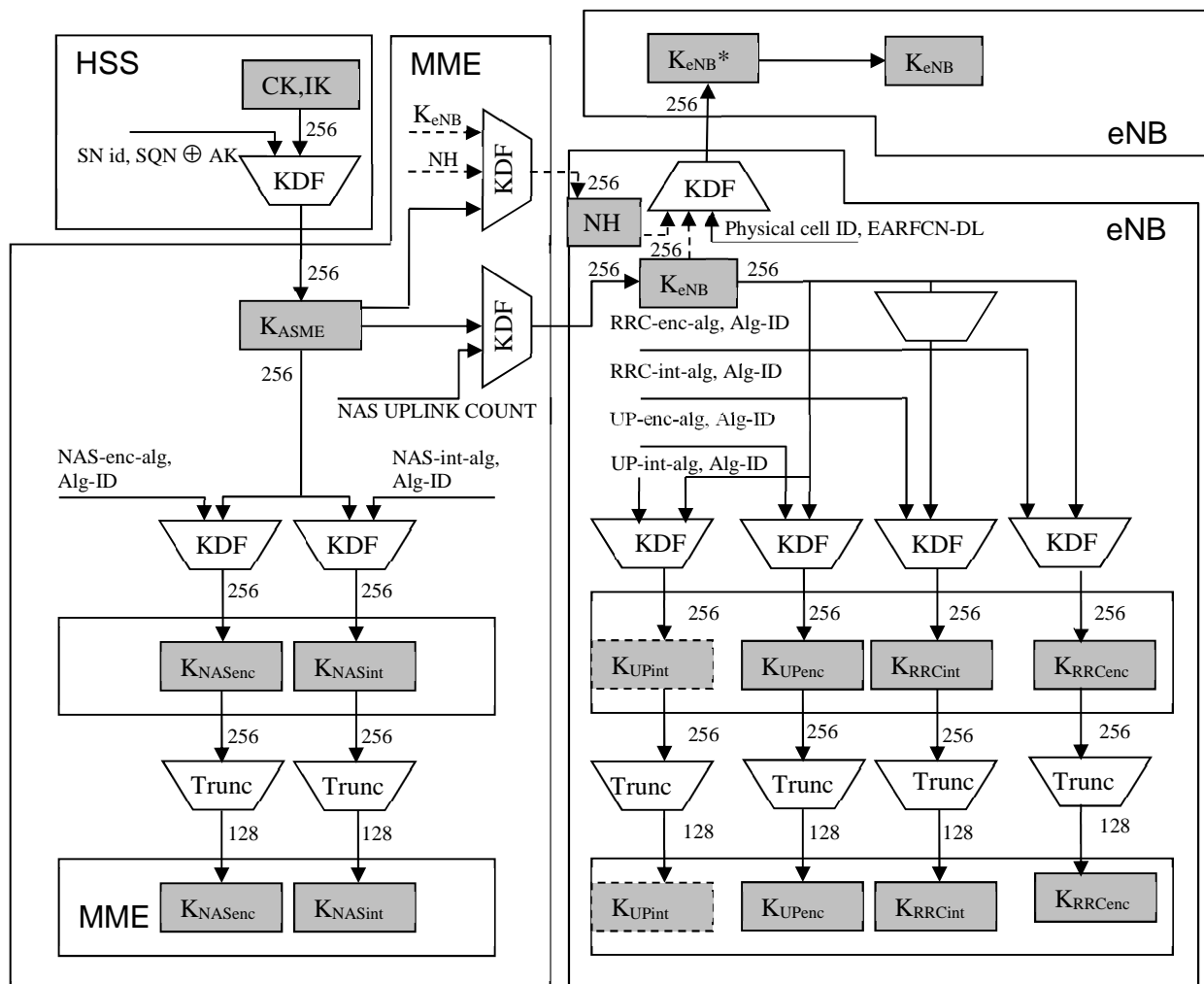

Figure 6.2-2: Key distribution and key derivation scheme for EPS (in particular E-UTRAN) for network nodes.

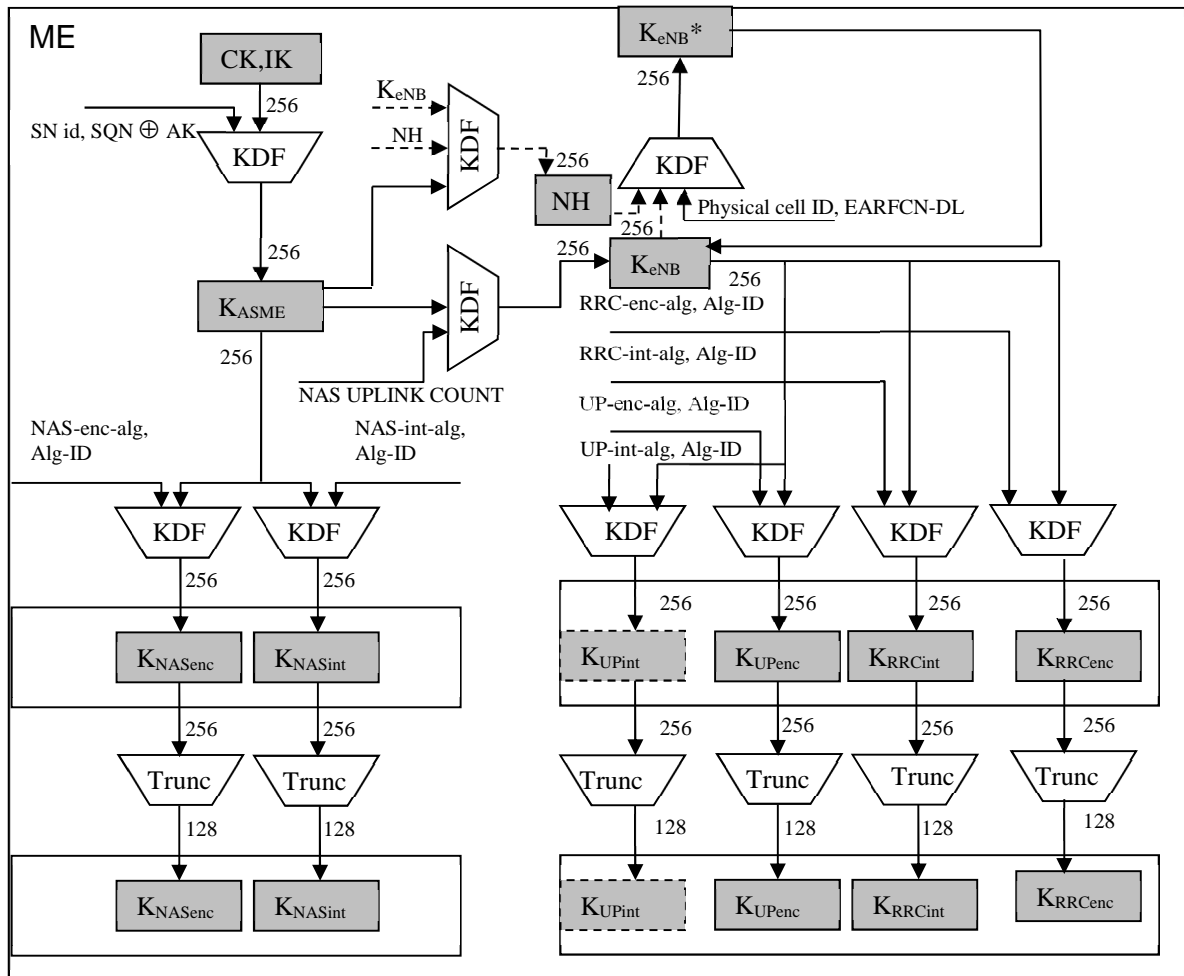

Figure 6.2-3: Key derivation scheme for EPS (in particular E-UTRAN) for the ME.

As the figures 6.2-2 and 6.2-3 show, the length of K_{ASME}, K_{eNB} and NH is 256 bits, 256-bit NAS, UP and RRC keys are always derived from K_{ASME} and K_{eNB} respectively. In case the encryption or integrity algorithm used to protect NAS, UP or RRC requires a 128-bit key as input, the key is truncated and the 128 least significant bits are used. Figures 6.2-2 and 6.2-3 illustrate the truncation to 128 bits keys.

The function Trunc takes as input a 256-bit string, and returns a truncated output as defined in Annex A.7.

6.3 EPS key identification

The key K_{ASME} shall be identified by the key set identifier eKSI. eKSI may be either of type KSI_{ASME} or of type KSI_{SGSN}. An eKSI shall be stored in the UE and the MME together with K_{ASME} and the temporary identifier GUTI, if available.

NOTE 1: The GUTI points to the MME where the K_{ASME} is stored.

The key set identifier KSI_{ASME} is a parameter which is associated with the K_{ASME} derived during EPS AKA authentication. The key set identifier KSI_{ASME} is allocated by the MME and sent with the authentication request message to the mobile station where it is stored together with the K_{ASME}. The purpose of the KSI_{ASME} is to make it possible for the UE and the MME to identify a native K_{ASME} without invoking the authentication procedure. This is used to allow re-use of the K_{ASME} during subsequent connection set-ups.

The key set identifier KSI_{SGSN} is a parameter which is associated with the mapped K_{ASME} derived from UMTS keys during inter-RAT mobility, cf. clauses 9 and 10 of the present specification. The key set identifier KSI_{SGSN} is generated in both the UE and the MME respectively when deriving the mapped K_{ASME} during idle procedures in E-UTRAN and during handover from GERAN/UTRAN to E-UTRAN. The KSI_{SGSN} is stored together with the mapped K_{ASME}.

The purpose of the KSI_{SGSN} is to make it possible for the UE and the MME to indicate the use of the mapped K_{ASME} in inter-RAT mobility procedures (for details cf. clauses 9 and 10).

The format of eKSI shall allow a recipient of such a parameter to distinguish whether the parameter is of type 'KSI_{ASME}' or of type 'KSI_{SGSN}'. The format shall further contain a value field. KSI_{ASME} and KSI_{SGSN} have the same format. The value fields of KSI_{ASME} and KSI_{SGSN} are three bits each. Seven values are used to identify the key set. A value of '111' is used by the UE to indicate that a valid K_{ASME} is not available for use. Format of eKSI is described in [9].

The value '111' in the other direction from network to mobile station is reserved.

NOTE 2: In addition to EPS security contexts, the UE may also cache UMTS security contexts. These UMTS security contexts are identified by the KSI, as defined in TS 33.102 [4].

6.4 Handling of EPS security contexts

Any EPS security context shall be deleted from the ME if:

- a) the UICC is removed from the ME when the ME is in power on state;
- b) the ME is powered up and the ME discovers that a UICC different from the one which was used to create the EPS security context has been inserted to the ME;
- c) the ME is powered up and the ME discovers that no UICC has been inserted to the ME.

K_{ASME} shall never be transferred from the EPC to an entity outside the EPC, with the exception of the following scenario(s):

- interworking from EPS to 5G as described in clause 8.2 and 8.4 of TS 33.501 [43].

Both the ME and MME shall be capable of storing one non-current EPS security context and one current EPS security context in volatile memory. In addition, while connected to E-UTRAN the ME and MME shall be capable of storing in volatile memory the NCC, NH and the related K_{ASME} used to compute keying material for the current EPS AS security context.

Any successful run of an EPS AKA creates, by the definition in clause 3, a partial native EPS security context. This context shall overwrite any existing non-current EPS security context.

UE shall use its current EPS security context to protect the TAU Request or Attach Request. However, there may be cases in which this EPS security context is not the current one in the MME. In such cases, if the MME receives a TAU Request or Attach Request protected with a non-current full EPS security context, then this context becomes the current EPS security context and the MME shall delete any existing current EPS security context.

After a successful run of a NAS SMC relating to the eKSI associated with an EPS security context, this context becomes the current EPS security context and shall overwrite any existing current EPS security context.

NOTE 1: The ME ensures that, whenever the native EPS NAS security context stored on the USIM (if supported by USIM) or in non-volatile memory of the ME is marked as valid during the process of changing state to EMM-DEREGISTERED, it is consistent with the security context stored in the volatile memory of the ME. This is described in clause 7.2.5.

The rules for handling security contexts after a handover to E-UTRAN are given in clause 9.2.2.1.

The full native EPS NAS security context (except for K_{NASenc} and K_{NASint}) shall be stored on the USIM (if the USIM supports EMM parameters storage) or in the non-volatile memory of the ME (if the USIM does not support EMM parameters storage) only during the process of transitioning to EMM-DEREGISTERED state or when an attempt to transition away from EMM-DEREGISTERED state fails, as described in clause 7.2.5. The ME shall under no other circumstances store the EPS NAS security context parameters on the USIM or non-volatile ME memory.

NOTE 2: Only native EPS NAS security context is stored in the EMM parameters file on the USIM or in non-volatile ME memory. A mapped EPS NAS security context is never stored in these two places.

6.5 Handling of NAS COUNTs

Each separate K_{ASME} has a distinct pair of NAS COUNTs, one NAS COUNT for uplink and one NAS COUNT for downlink, associated with it.

It is essential that the NAS COUNTs for a particular K_{ASME} are not reset to the start values (that is the NAS COUNTs only have their start value when a new K_{ASME} is created). This prevents the security issue of using the same NAS COUNTs with the same NAS keys, e.g. key stream re-use, in the case a UE moves back and forth between two MMEs and the same NAS keys are re-derived.

The NAS COUNTs shall only be set to the start value in the following cases:

- for a partial native EPS NAS security context created by a successful AKA run,

NOTE: The NAS COUNTs are not actually needed at the UE for a native context until it has successfully received the first NAS Security Mode Command for that security context. The NAS COUNTs are not needed at the MME until it sends the first NAS Security Mode Command for that security context. Before the MME sends the first NAS Security Mode Command for a given partial native security context, the MME sets the NAS COUNTs for the security context to 0. After the NAS SMC message is sent for that partial native security context the NAS COUNTs for that partial native context are increased for each following sent NAS message as specified in TS 24.301.

- or for an EPS NAS security context created through a context mapping during a handover from UTRAN/GERAN to E-UTRAN,
- or for an EPS NAS security context created through a context mapping during idle mode mobility from UTRAN/GERAN to E-UTRAN.

The NAS COUNTs shall not be reset during idle mode mobility or handover for an already existing native EPS NAS security context.

The start value of NAS COUNT shall be zero (0).

7 Security procedures between UE and EPS access network elements

7.0 General

The statements relating to eNBs in clause 7 apply also to RNs regarding the security between a UE and a relay node.

The statements relating to UEs in clause 7 apply also to RNs regarding the security between a relay node and a Donor eNB and between a relay node and its MME unless stated otherwise.

7.1 Mechanism for user identity confidentiality

The MME shall allocate a GUTI to a UE in order to support the subscriber identity confidentiality. The GUTI is defined in TS 23.003 [3].

S-TMSI, the shortened form of the GUTI, is used to support the subscriber identity confidentiality with more efficient radio signalling procedures (e.g. paging and Service Request). A new GUTI shall be sent to the UE only after a successful activation of NAS security.

7.2 Handling of user-related keys in E-UTRAN

7.2.1 E-UTRAN key setting during AKA

Authentication and key setting are triggered by the authentication procedure. Authentication and key setting may be initiated by the network as often as the network operator wishes. Key setting can occur as soon as the identity of the mobile subscriber (i.e. GUTI or IMSI) is known by the MME. A successful run of AKA results in a new K_{ASME} that is stored in the UE and MME.

NAS keys, K_{eNB} and the RRC and UP keys are derived from K_{ASME} using the KDFs specified in Annex A.

The NAS keys derived from the new K_{ASME} are taken in use in the MME and the UE by means of the NAS security mode set-up procedure (see subclause 7.2.4.4). The AS keys are taken into use with the AS security mode set-up procedure (see subclause 7.2.4.5) or with the key change on the fly procedure (see subclause 7.2.9.2).

7.2.2 E-UTRAN key identification

Clause 6.3 of this specification states how the key K_{ASME} is identified, namely by the key set identifier eKSI. Keys K_{NASenc} and K_{NASint} in the E-UTRAN key hierarchy specified in clause 6.2, which are derived from K_{ASME} , can be uniquely identified by eKSI together with those parameters from the set {algorithm distinguisher, algorithm identifier}, which are used to derive these keys from K_{ASME} according to Annex A.

The initial K_{eNB} can be uniquely determined by the key set identifier, i.e. eKSI, together with the uplink NAS COUNT are used to derive it. The intermediate key NH as defined in clause 7 can be uniquely determined by the key set identifier, i.e. eKSI, together with the initial K_{eNB} derived from the current NAS security context for use during the ongoing CONNECTED state and a counter counting how many NH-derivations have already been performed from this initial K_{eNB} . according to Annex A.4. The next hop chaining count, NCC, represents the 3 least significant bits of this counter.

Intermediate key K_{eNB}^* , defined in clause 7, as well as keys non-initial K_{eNB} , K_{RRCint} , K_{RRCenc} , K_{UPint} , and K_{UPenc} in the E-UTRAN key hierarchy specified in clause 6.2 can be uniquely identified by eKSI together with those parameters from the set {Initial K_{eNB} or NH, algorithm distinguisher, algorithm identifier, and sequence of PCIs and EARFCN-DLs used in horizontal key derivations from the initial K_{eNB} or NH}, which are used to derive these keys from K_{ASME} according to clause 7 and clause A.7.

It is specified in the remainder of clause 7, as well as in clause 9 and 10, which of the above parameters need to be included in a security-relevant message to allow the entity receiving the message to uniquely identify a certain key.

7.2.3 E-UTRAN key lifetimes

All E-UTRAN keys are derived based on a K_{ASME} . The key hierarchy which is described in clause 6.2 does not allow direct update to RRC and UP keys, but fresh RRC and UP keys are derived based on a fresh K_{eNB} , which is bound to certain dynamic parameters (like PCI) or fresh key derivation parameter(s) in state transitions (like NAS uplink COUNT). This results as fresh RRC and UP keys in the eNB between inter-eNB handovers and state transitions (see subclauses 7.2.6 to 7.2.8). The handling (creation, modification and update) of the E-UTRAN keys in the various state transitions is described in clauses 7.2.5, 7.2.6, 7.2.7 and 7.2.8.

K_{ASME} shall be created only by running a successful AKA or by the inter-RAT procedures towards E-UTRAN (cf clauses 9 and 10). In case the UE does not have a valid K_{ASME} , a KSI_{ASME} with value "111" shall be sent by the UE to the network, which can initiate (re-)authentication procedure to get a new K_{ASME} based on a successful AKA authentication.

7.2.4 Security mode command procedure and algorithm negotiation

7.2.4.1 Requirements for algorithm selection

- a) An active UE and a serving network shall agree upon algorithms for
 - RRC ciphering and RRC integrity protection (to be used between UE and eNB)
 - UP ciphering (to be used between UE and eNB)
 - NAS ciphering and NAS integrity protection (to be used between UE and MME)An active RN and a network serving the RN shall additionally agree upon algorithms for UP integrity.
- b) The serving network shall select the algorithms to use dependent on
 - the UE security capabilities of the UE,
 - the configured allowed list of security capabilities of the currently serving network entity
- c) The same set of ciphering and integrity algorithms shall be supported by the UE both for AS and NAS level.
- d) Each selected algorithm shall be acknowledged to the UE in an integrity protected way such that the UE is ensured that the algorithm selection was not manipulated, i.e. that the UE security capabilities were not bidden down.
- e) The UE security capabilities the ME sent to the network shall be repeated in an integrity protected NAS level message to the ME such that "bidding down attacks" against the UE's security capabilities can be detected by the ME. The UE security capabilities apply to both AS and NAS level security.
- f) Separate AS and NAS level security mode command procedures are required. AS level security mode command procedure shall configure AS security (RRC and UP) and NAS level security mode command procedure shall configure NAS security.
 - a) Both integrity protection and ciphering for RRC shall be activated within the same AS SMC procedure, but not necessarily within the same message.
 - b) User plane ciphering shall be activated at the same time as RRC ciphering.
 - c) User plane integrity shall be activated at the same time as RRC ciphering. User plane integrity shall be applied to a data radio bearer if integrity protection is configured for that data radio bearer at the time of data radio bearer set-up.

- g) It shall be possible that the selected AS and NAS algorithms are different at a given point of time.

7.2.4.2 Procedures for AS algorithm selection

7.2.4.2.1 Initial AS security context establishment

Each eNB shall be configured via network management with lists of algorithms which are allowed for usage. There shall be one list for integrity algorithms, and one for ciphering algorithms. These lists shall be ordered according to a priority decided by the operator. When AS security context is established in the eNB, the MME shall send the UE EPS security capabilities to the eNB. The eNB shall choose the ciphering algorithm which has the highest priority from its configured list and is also present in the UE EPS security capabilities. The eNB shall choose the integrity algorithm which has the highest priority from its configured list and is also present in the UE EPS security capabilities. The chosen algorithms shall be indicated to the UE in the AS SMC. The ciphering algorithm is used for ciphering of the user plane and RRC traffic. The integrity algorithm is used for integrity protection of the RRC traffic, and, if applicable, for the integrity protection of user plane traffic between RN and DeNB.

7.2.4.2.2 X2-handover

At handover from a source eNB over X2 to a target eNB, the source eNB shall include the UE EPS security capabilities and ciphering and integrity algorithms used in the source cell in the handover request message. The target eNB shall select the algorithm with highest priority from the UE EPS security capabilities according to the prioritized locally configured list of algorithms (this applies for both integrity and ciphering algorithms). The chosen algorithms shall be indicated to the UE in the handover command if the target eNB selects different algorithms compared to the source eNB. If the UE does not receive any selection of integrity and ciphering algorithms it continues to use the same algorithms as before the handover (see TS 36.331 [21]). In the path-switch message, the target eNB shall send the UE EPS security capabilities received from the source eNB to the MME. The MME shall verify that the UE EPS security capabilities received from the eNB are the same as the UE EPS security capabilities that the MME has stored. If there is a mismatch, the MME may log the event and may take additional measures, such as raising an alarm.

NOTE: Transferring the ciphering and integrity algorithms used in the source cell to the target eNB in the handover request message is for the target eNB to decipher and integrity verify the RRCReestablishmentComplete message on SRB1 in the potential RRCConnectionRe-establishment procedure. The information is also used by the target eNB to decide if it is necessary to include a new selection of security algorithms in the handover command.

7.2.4.2.3 S1-handover

At handover from a source eNB to a target eNB over S1 (possibly including an MME change and hence a transfer of the UE security capabilities from source MME to target MME), the target MME shall send the UE EPS security capabilities to the target eNB in the S1 AP HANDOVER REQUEST message. The target eNB shall select the algorithm with highest priority from the UE EPS security capabilities according to the prioritized locally configured list of algorithms (this applies for both integrity and ciphering algorithms). The chosen algorithms shall be indicated to the UE in the handover command if the target eNB selects different algorithms compared to the source eNB. If the UE does not receive any selection of integrity and ciphering algorithms it continues to use the same algorithms as before the handover (see TS 36.331 [21]).

7.2.4.2.4 Intra-eNB handover

It is not required to change the AS security algorithm during intra-eNB handover. If the UE does not receive any selection of new AS security algorithms during an intra-eNB handover, the UE continues to use the same algorithms as before the handover (see TS 36.331 [21]).

7.2.4.3 Procedures for NAS algorithm selection

7.2.4.3.1 Initial NAS security context establishment

Each MME shall be configured via network management with lists of algorithms which are allowed for usage. There shall be one list for NAS integrity algorithms, and one for NAS ciphering algorithms. These lists shall be ordered according to a priority decided by the operator.

To establish the NAS security context, the MME shall choose one NAS ciphering algorithm and one NAS integrity protection algorithm. The MME shall then initiate a NAS security mode command procedure, and include the chosen algorithms and UE security capabilities (to detect modification of the UE security capabilities by an attacker) in the message to the UE (see clause 7.2.4.4). The MME shall select the NAS algorithms which have the highest priority according to the ordered lists.

7.2.4.3.2 MME change

In case there is change of MMEs and algorithms to be used for NAS, the target MME shall initiate a NAS security mode command procedure and include the chosen algorithms and the UE security capabilities (to detect modification of the UE security capabilities by an attacker) in the message to the UE (see clause 7.2.4.4). The MME shall select the NAS algorithms which have the highest priority according to the ordered lists (see 7.2.4.3.1).

NOTE: After an S1-handover with MME change a TAU procedure is executed. The same is true for an inter-RAT handover to E-UTRAN and for both inter- and intra-RAT idle mode mobility resulting in a change of MMEs.

7.2.4.4 NAS security mode command procedure

The NAS SMC procedure consists of a roundtrip of messages between MME and UE. The MME sends the NAS Security Mode Command to the UE and the UE replies with the NAS Security Mode Complete message. The primary purpose of the NAS SMC procedure is to securely establish a NAS security context between the UE and MME.

NOTE 1: The NAS SMC procedure is designed such that it protects the establishment of the NAS security against a man-in-the-middle attack where the attacker modifies the IEs containing the UE security capabilities provided by the UE in the Attach or TAU Request. It works as follows: if the method completes successfully, the UE is attached to the network knowing that no bidding down attack has happened. In case a bidding down attack was attempted, the verification of the NAS SMC will fail and the UE replies with a reject message.

The NAS Security Mode Command message from MME to UE shall contain the replayed UE security capabilities, the selected NAS algorithms, the eKSI for identifying K_{ASME} , and both $NONCE_{UE}$ and $NONCE_{MME}$ in the case of creating a mapped context in idle mobility (see clause 9.1.2). The replayed UE security capabilities shall include the UE NR security capabilities if the MME understands the UE NR security capabilities and received them from the UE. In the case of sending a NAS Security Mode Command during an Attach or TAU procedure (i.e. after receiving the Attach/TAU Request but before sending a response to that message) where the relevant Request message either did not have an integrity protection or did not successfully pass its integrity protection, the MME shall calculate a $HASH_{MME}$ of the entire plain Request message and include the $HASH_{MME}$ in the NAS security mode command message. The MME shall calculate $HASH_{MME}$ as described in Annex I.2. This message shall be integrity protected (but not ciphered) with NAS integrity key based on K_{ASME} indicated by the eKSI in the message (see figure 7.2.4.4-1).

The UE shall verify the integrity of the NAS Security Mode Command message. This includes ensuring that the UE security capabilities sent by the MME match the ones stored in the UE to ensure that these were not modified by an attacker. If the UE NR security capabilities are not included, the UE shall not consider this a mismatch of security capabilities. The verification also includes checking the integrity protection using the indicated NAS integrity algorithm and the NAS integrity key based on K_{ASME} indicated by the eKSI. In addition, when creating a mapped context for the case described in clause 9.1.2, the UE shall ensure the received $NONCE_{UE}$ is the same as the $NONCE_{UE}$ sent in the TAU Request and also calculate K'_{ASME} from CK, IK and the two nonces (see Annex A.11).

In addition if the NAS Security Mode Command message includes a $HASH_{MME}$, the UE shall compare $HASH_{UE}$ with $HASH_{MME}$. The UE shall calculate $HASH_{UE}$ as described in Annex I.2 from the entire plain Attach Request or TAU Request that it sends.

NOTE 2: The UE could calculate the $HASH_{UE}$ after it sends the Attach Request or TAU Request and before it receives the NAS Security Mode Command message. Alternatively, the UE could calculate the $HASH_{UE}$ after successfully verifying a NAS security mode command message that includes a $HASH_{MME}$.

If the MME receives no response to a NAS Security Mode Command that included nonces to create a mapped context and it wishes to try again to create the mapped context, the MME shall use the same values of $NONCE_{UE}$ and $NONCE_{MME}$.

If the UE receives a re-transmitted NAS Security Mode Command, i.e. one containing the nonces, after it has successfully received a previous one (and hence created a mapped EPS NAS security context), the UE shall process the

message as above, except that it is not required to re-generate the K'_{ASME} or check the $NONCE_{UE}$ if it does not re-generate the K'_{ASME} .

If the checks of the NAS Security Mode Command pass the UE shall respond with a NAS Security Mode Complete.

The UE shall delete $NONCE_{UE}$ once the TAU procedure is complete.

If successfully verified, the UE shall start NAS integrity protection and ciphering/deciphering with this security context and sends the NAS security mode complete message to MME ciphered and integrity protected. The NAS Security Mode Complete message shall include IMEISV in case MME requested it in the NAS Security Mode Command message. In addition if $HASH_{UE}$ and $HASH_{MME}$ are different, the UE shall include the complete Attach/TAU Request message (that the UE previously sent) in the NAS Security Mode Complete message.

NOTE3 : A failed Hash comparison does not affect the security establishment as the UE has still checked the UE security capabilities that the MME sent in the NAS Security Mode Command message.

The MME shall de-cipher and check the integrity protection on the NAS Security Mode Complete using the keys and algorithms indicated in the NAS Security Mode Command. NAS downlink ciphering at the MME with this security context shall start after receiving the NAS Security Mode Complete message. NAS uplink deciphering at the MME with this context starts after sending the NAS Security Mode Command message. If the NAS Security Mode Complete message contains an Attach/TAU Request message, the MME shall complete the on-going Attach/TAU procedure by considering the contained Attach/TAU Request message as the message that triggered the procedure.

If any verification of the NAS Security Mode Command is not successful in the ME, the ME shall reply with a NAS Security Mode Reject message (see TS 24.301 [9]). The NAS Security Mode Reject message and all following NAS messages shall be protected with the EPS NAS security context, i.e., the EPS NAS security context used prior to the NAS Security Mode Command that failed (until a new EPS NAS security context is established, e.g., via a new NAS security mode command procedure). If no EPS NAS security context existed prior to the NAS Security Mode Command, the NAS Security Mode Reject message cannot be protected.

NOTE 4: If the uplink NAS COUNT will wrap around by sending the Security Mode Reject message, the UE releases the NAS connection as specified in TS 24.301 [9] instead of sending the Security Mode Reject message.

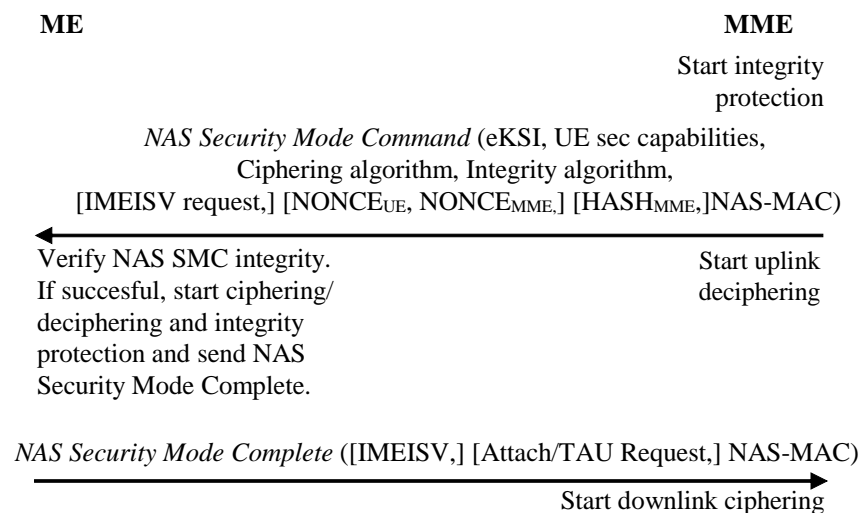

Figure 7.2.4.4-1: NAS Security Mode Command procedure

7.2.4.5 AS security mode command procedure

The AS SMC procedure consists of a roundtrip of messages between eNB and UE. The eNB sends the AS security mode command to the UE and the UE replies with the AS security mode complete message. See figure 7.2.4.5-1.

The AS security mode command message from eNB to UE shall contain the selected AS algorithms. This message shall be integrity protected with RRC integrity key based on the current K_{ASME} .

The AS security mode complete message from UE to eNB shall be integrity protected with the selected RRC algorithm indicated in the AS security mode command message and RRC integrity key based on the current K_{ASME} .

RRC and UP downlink ciphering (encryption) at the eNB shall start after sending the AS security mode command message. RRC and UP uplink deciphering (decryption) at the eNB shall start after receiving and successful verification of the AS security mode complete message.

RRC and UP uplink ciphering (encryption) at the UE shall start after sending the AS security mode complete message. RRC and UP downlink deciphering (decryption) at the UE shall start after receiving and successful verification of the AS security mode command message.

If any control of the AS security mode command is not successful in the ME, the ME shall reply with an unprotected security mode failure message (see TS 36.331[21]).

AS security mode command always changes the AS keys.

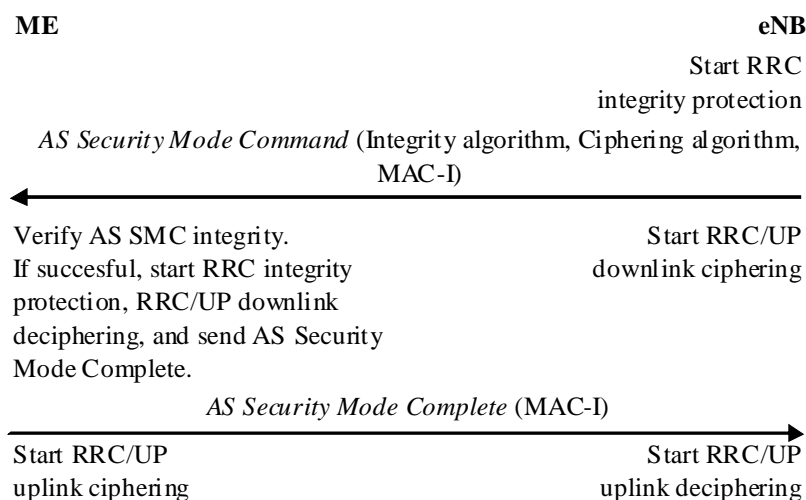

Figure 7.2.4.5-1: AS security setup

7.2.4a Algorithm negotiation for unauthenticated UEs in LSM

UEs that are in limited service mode (LSM) and that cannot be authenticated by the MME (for whatever reason) may still be allowed to establish emergency calls by sending the emergency attach request message. It shall be possible to configure whether the MME allows unauthenticated UEs in LSM to establish bearers for emergency calls or not. If an MME allows unauthenticated UEs in LSM to establish bearers for an emergency call, the MME shall for the NAS protocol use EIA0 and EEA0 as the integrity and ciphering algorithm respectively.

If the MME allows an unauthenticated UE in LSM to establish bearers for emergency calls after it has received the emergency attach request message from the UE, the MME shall:

- Select EIA0 and EEA0, regardless of the supported algorithms announced previously by the UE as the NAS algorithms and signal this to the UE via the NAS security mode command procedure when activating the EPS NAS security context.
- Set the UE EPS security capabilities to only contain EIA0 and EEA0 when sending these to the eNB in the following messages:
 - S1 UE INITIAL CONTEXT SETUP
 - S1 UE CONTEXT MODIFICATION REQUEST
 - S1 HANDOVER REQUEST

NOTE 1: As a result of that the MME only sends a UE EPS security capability containing EIA0 and EEA0 to the eNB when selecting EIA0 for NAS integrity protection is that the eNB is only capable of selecting EIA0 for AS integrity protection and EEA0 for AS confidentiality protection. That is, if EIA0 is used for NAS integrity protection, then EIA0 will always be used for AS integrity protection.

The rules for when the MME shall select EIA0 for NAS integrity protection, and when the UE shall accept a NAS security mode command selecting EIA0 for NAS integrity protection depends on whether the UE and MME can be certain that no EPS NAS security context can be established. The rules for determining this is defined in clause 15 of this specification. If the MME has selected EIA0 as the NAS integrity protection algorithm, the UE shall accept selection of EIA0 as the AS integrity protection algorithm. Selection of AS integrity protection algorithm happens via the AS security mode command procedure or via a handover command. The UE shall under no other circumstances accept selection of EIA0 as the AS integrity protection algorithm.

NOTE 2: A Rel-8 eNB that is the target eNB of a handover, where EIA0 is the only integrity protection algorithm in the UE's EPS security capabilities, rejects the handover since the eNB does not support EIA0.

7.2.5 Key handling at state transitions to and away from EMM-DEREGISTERED

7.2.5.1 Transition to EMM-DEREGISTERED

There are different reasons for transition to the EMM-DEREGISTERED state. If a NAS messages leads to state transition to EMM-DEREGISTERED, it shall be security protected by the current EPS NAS security context (mapped or native), if such exists in the UE or MME.

NOTE: The present specification only considers the states EMM-DEREGISTERED and EMM-REGISTERED and transitions between these two states. Other specifications define additional EMM states (see, e.g., TS 24.301 [9]).

On transitioning to EMM-DEREGISTERED, the UE and MME shall do the following:

1. If they have a full non-current native EPS NAS security context and a current mapped EPS NAS security context, then they shall make the non-current native EPS NAS security context the current one.
2. They shall delete any mapped or partial EPS NAS security contexts they hold.

Handling of the remaining authentication data for each of these cases are given below:

1. Attach reject: All authentication data shall be removed from the UE and MME
2. Detach:
 - a. UE-initiated
 - i. If the reason is switch off then all the remaining authentication data shall be removed from the UE and MME with the exception of:
 - the current native EPS NAS security context (as in clause 6.1.1), which should remain stored in the MME and UE, and
 - any unused authentication vectors, which may remain stored in the MME.
 - ii. If the reason is not switch off then MME and UE shall keep all the remaining authentication data.
 - b. MME-initiated
 - i. Explicit: all the remaining authentication data shall be kept in the UE and MME if the detach type is re-attach.
 - ii. Implicit: all the remaining authentication data shall be kept in the UE and MME.
 - c. HSS-initiated: If the message is "subscription withdrawn" then all the remaining authentication data shall be removed from the UE and MME.
3. TAU reject: There are various reasons for TAU reject. The action to be taken shall be as given in TS 24.301.

Storage of the full native EPS NAS security context, excluding the UE security capabilities and the keys K_{NASint} and K_{NASenc} , in the UE when the UE transitions to EMM-DEREGISTERED state is done as follows:

- a) If the ME does not have a full native EPS NAS security context in volatile memory, any existing native EPS NAS security context stored on the UICC or in non-volatile memory of the ME shall be marked as invalid.
- b) If the USIM supports EMM parameters storage, then the ME shall store the full native EPS NAS security context parameters on the USIM (except for K_{NASenc} and K_{NASint}), mark the native EPS NAS security context on the USIM as valid, and not keep any native EPS NAS security context in non-volatile ME memory.
- c) If the USIM does not support EMM parameters storage, then the ME shall store the full native EPS NAS security context (except for K_{NASenc} and K_{NASint}) in a non-volatile part of its memory, and mark the native EPS NAS security context in its non-volatile memory as valid.

For the case that the MME or the UE enter EMM-DEREGISTERED state without using any of the above procedures, the handling of the remaining authentication data shall be as specified in TS 24.301 [9].

7.2.5.2 Transition away from EMM-DEREGISTERED

7.2.5.2.1 General

When starting the transition away from EMM-DEREGISTERED state with the intent to eventually transitioning to EMM-REGISTERED state, if no current EPS NAS security context is available in the ME, the ME shall retrieve native EPS NAS security context stored on the USIM if the USIM supports EMM parameters storage and if the stored native EPS NAS security context on the USIM is marked as valid. If the USIM does not support EMM parameters storage the ME shall retrieve stored native EPS NAS security context from its non-volatile memory if the native EPS NAS security context is marked as valid. The ME shall derive the K_{NASint} and K_{NASenc} after retrieving the stored EPS NAS security context; see clause A.7 on NAS key derivation. The retrieved native EPS NAS security context with the derived K_{NASint} and K_{NASenc} shall then become the current EPS NAS security context.

When the ME is transitioning away from EMM-DEREGISTERED state with the intent to eventually transitioning to EMM-REGISTERED state, if the USIM supports EMM parameters storage, the ME shall mark the stored EPS NAS security context on the USIM as invalid. If the USIM does not support EMM parameters storage, the ME shall mark the stored EPS NAS security context in its non-volatile memory as invalid.

If the ME uses an EPS NAS security context to protect NAS messages, the NAS COUNT values are updated in the volatile memory of the ME. If the attempt to transition away from EMM-DEREGISTERED state with the intent to eventually transitioning to EMM-REGISTERED state fails, the ME shall store the (possibly updated) EPS NAS security context on the USIM or non-volatile ME memory and mark it as valid.

NOTE: The present specification only considers the states EMM-DEREGISTERED and EMM-REGISTERED and transitions between these two states. Other specifications define additional EMM states (see, e.g., TS 24.301 [9]).

When the UE transits from EMM-DEREGISTERED to EMM-REGISTERED/ECM-CONNECTED, there are two cases to consider, either a full native EPS NAS security context exists, or it does not.

7.2.5.2.2 With existing native EPS NAS security context

The UE shall transmit a NAS Attach Request message. This message is integrity protected and for the case that the EPS NAS security context used by the UE is non-current in the MME, the rules in clause 6.4 apply. Furthermore provided there is no NAS SMC procedure before the AS SMC the NAS COUNT of the Attach Request message shall be used to derive the K_{eNB} with the KDF as specified in clause A.3. As a result of the NAS Attach Request, the eNB shall send an AS SMC to the UE to activate AS security. The K_{eNB} used, is derived in the current EPS NAS security context.

When the UE receives the AS SMC without having received a NAS Security Mode Command after the Attach Request, it shall use the NAS COUNT of the Attach Request message (i.e. the uplink NAS COUNT) that triggered the AS SMC to be sent as freshness parameter in the derivation of the K_{eNB} . From this K_{eNB} the RRC protection keys and the UP protection keys shall be derived as described in subclause 7.2.1.

The same procedure for refreshing K_{eNB} can be used regardless of the fact if the UE is connecting to the same MME to which it was connected previously or to a different MME. In case UE connects to a different MME and this MME

selects different NAS algorithms, the NAS keys have to be re-derived in the MME with the new algorithm IDs as input using the KDF as specified in clause A.7.

In addition, there is a need for the MME to send a NAS SMC to the UE to indicate the change of NAS algorithms and to take the re-derived NAS keys into use. The UE shall assure that the NAS keys used to verify the integrity of the NAS SMC are derived using the algorithm ID specified in the NAS SMC. The NAS SMC Command and NAS SMC Complete messages are protected with the new NAS keys.

If there is a NAS Security Mode Command after the Attach Request but before the AS SMC, the UE and MME use the NAS COUNT of the most recent NAS Security Mode Complete (i.e. the uplink NAS COUNT) and the related K_{ASME} as the parameter in the derivation of the K_{eNB} . From this K_{eNB} the RRC protection keys and the UP protection keys are derived as described in subclause 7.2.1.

7.2.5.2.3 With run of EPS AKA

If in the process described in clause 7.2.5.2.2, there is no full native EPS NAS security context available in the MME (i.e. either the UE has sent an unprotected Attach Request message or the UE has protected the Attach Request message with a current native EPS security context which no longer is stored in the MME) an EPS AKA run is required. If there is a full native EPS NAS security context available in the MME, then the MME may (according to MME policy) decide to run a new EPS AKA and a NAS SMC procedure (which activates the new EPS NAS security context based on the K_{ASME} derived during the EPS AKA run) after the Attach Request but before the corresponding AS SMC. The NAS (uplink and downlink) COUNTs are set to start values, and the start value of the uplink NAS COUNT shall be used as freshness parameter in the K_{eNB} derivation from the fresh K_{ASME} (after AKA) when UE receives AS SMC the K_{eNB} is derived from the current EPS NAS security context, i.e., the fresh K_{ASME} is used to derive the K_{eNB} . The KDF as specified in clause A.3 shall be used to derive the K_{eNB} .

NOTE: Using the start value for the uplink NAS COUNT in this case cannot lead to the same combination of K_{ASME} and NAS COUNT being used twice. This is guaranteed by the fact that the first integrity protected NAS message the UE sends to the MME after AKA is the NAS SMC complete message.

The NAS SMC complete message shall include the start value of the uplink NAS COUNT that is used as freshness parameter in the K_{eNB} derivation and the K_{ASME} is fresh. After an AKA, a NAS SMC needs to be sent from the MME to the UE in order to take the new NAS keys into use. Both NAS SMC and NAS SMC Complete messages are protected with the new NAS keys.

7.2.6 Key handling in ECM-IDLE to ECM-CONNECTED and ECM-CONNECTED to ECM-IDLE transitions

7.2.6.1 ECM-IDLE to ECM-CONNECTED transition

The UE sends an initial NAS message to initiate transition from ECM-IDLE to ECM-CONNECTED state [9]. On transitions to ECM-CONNECTED, the MME should be able to check whether a new authentication is required, e.g. because of prior inter-provider handover.

When cryptographic protection for radio bearers is established RRC protection keys and UP protection keys shall be generated as described in subclause 7.2.1 while K_{ASME} is assumed to be already available in the MME.

The initial NAS message shall be integrity protected by the current EPS NAS security context if such exists. If no current EPS NAS security context exists the ME shall signal "no key available" in the initial NAS message.

K_{ASME} may have been established in the MME as a result of an AKA run, or as a result of a security context transfer from another MME during handover or idle mode mobility. When the eNB releases the RRC connection the UE and the eNB shall delete the keys they store such that state in the network for ECM-IDLE state UEs will only be maintained in the MME.

7.2.6.2 Establishment of keys for cryptographically protected radio bearers

The procedure the UE uses to establish cryptographic protection for radio bearers is initiated by an (extended) NAS Service Request message or TAU Request message with the active flag set from the UE to the MME. The MME may initiate the procedure to establish cryptographic protection for radio bearers when the "active flag" is not set in the TAU request and there is pending downlink UP data or pending downlink signalling.

Upon receipt of the NAS message, if the MME does not require a NAS SMC procedure before initiating the S1-AP procedure INITIAL CONTEXT SETUP, the MME shall derive key K_{eNB} as specified in subclause A.3 using the NAS COUNT [9] corresponding to the NAS message and the K_{ASME} of the current EPS NAS security context. The MME shall further initialize the value of the Next hop Chaining Counter (NCC) to zero. The MME shall further derive a next hop parameter NH as specified in subclause A.4 using the newly derived K_{eNB} and the K_{ASME} as basis for the derivation. The MME shall further set the the value of the Next hop Chaining Counter (NCC) to one. This fresh {NH, NCC=1} pair shall be stored in the MME and shall be used for the next forward security key derivation. The MME shall communicate the K_{eNB} to the serving eNB in the S1-AP procedure INITIAL CONTEXT SETUP. The UE shall derive the K_{eNB} from the K_{ASME} of the current EPS NAS security context.

As a result of the (extended) NAS Service Request or TAU procedure, radio bearers are established, and the eNB sends an AS SMC to the UE. When the UE receives the AS SMC without having received a NAS Security Mode Command, it shall use the NAS uplink COUNT of the NAS message that triggered the AS SMC as freshness parameter in the derivation of the K_{eNB} . The KDF as specified in Annex A.3 shall be used for the K_{eNB} derivation using the K_{ASME} of the current EPS NAS security context. The UE shall further derive the NH parameter from the newly derived K_{eNB} and the K_{ASME} in the same way as the MME. From the K_{eNB} the RRC protection keys and the UP protection keys are derived by the UE and the eNB as described in subclause 6.2.

NOTE: At the UE, the NH derivation associated with NCC=1 could be delayed until the first handover performing vertical key derivation.

If the NAS procedure establishing radio bearers contains an EPS AKA run (which is optional), the NAS uplink and downlink COUNT for the new K_{ASME} shall be set to the start values (i.e. zero). If the NAS procedure establishing radio bearers contains a NAS SMC (which is optional), the value of the uplink NAS COUNT from the most recent NAS Security Mode Complete shall be used as freshness parameter in the K_{eNB} derivation from fresh K_{ASME} of the current EPS NAS security context when executing an AS SMC. The KDF as specified in Annex A.3 shall be used for the K_{eNB} derivation also in this case.

The case that the UE is using Control Plane CIoT EPS optimisation to send data over NAS and S1-U bearers are established (due to either a request from the UE or decided by the MME - see 5.3.4B.3 of TS 23.401 [2]) works as follows. The UE and MME shall always use the value of the uplink NAS COUNT from the Control Plane Service Request that was sent to transition the UE from idle to active as freshness parameter in the derivation of the K_{eNB} unless there has been a subsequent NAS Security Mode Complete. If there was a subsequent NAS Security Mode Complete, then the UE and MME use the value of the uplink NAS COUNT from the latest NAS Security Mode Complete message as freshness parameter in the derivation of the K_{eNB} .

7.2.6.3 ECM-CONNECTED to ECM-IDLE transition

On ECM-CONNECTED to ECM-IDLE transitions the eNB does no longer need to store state information about the corresponding UE.

In particular, on ECM-CONNECTED to ECM-IDLE transitions:

- The eNB and the UE shall release all radio bearers and delete the AS security context.
- MME and the UE shall keep the EPS NAS security context stored with the following exception: if there is a new and an old K_{ASME} according to rules 3, 4, 8 or 9 in clause 7.2.10 of this specification then the MME and the UE shall delete the old K_{ASME} and the corresponding eKSI. The MME shall delete NH and NCC.

7.2.7 Key handling for the TAU procedure when registered in E-UTRAN

Before the UE can initiate the TAU procedure, the UE needs to transition to ECM-CONNECTED state. The UE shall use the current EPS security context to protect the TAU Request and include the corresponding GUTI and eKSI value. The TAU Request shall be integrity-protected, but not confidentiality-protected. UE shall use the current EPS security context algorithms to protect the TAU Request message. For the case that this security context is non-current in the MME, the rules in clause 6.4 apply.

If the "active flag" is set in the TAU request message or the MME chooses to establish radio bearers when there is pending downlink UP data or pending downlink signalling, radio bearers will be established as part of the TAU procedure and a K_{eNB} derivation is necessary. If there was no subsequent NAS SMC, the uplink NAS COUNT of the TAU request message sent from the UE to the MME is used as freshness parameter in the K_{eNB} derivation using the KDF as specified in clause A.3. The TAU request shall be integrity protected.

In the case an AKA is run successfully, the uplink and downlink NAS COUNT shall be set to the start values (i.e. zero).

In the case source and target MME use different NAS algorithms, the target MME re-derives the NAS keys from K_{ASME} with the new algorithm identities as input and provides the new algorithm identifiers within a NAS SMC. The UE shall assure that the NAS keys used to verify the integrity of the NAS SMC are derived using the algorithm identity specified in the NAS SMC.

If there is a NAS Security Mode Command after the TAU Request but before the AS SMC, the UE and MME use the NAS COUNT of the most recent NAS Security Mode Complete (i.e. the uplink NAS COUNT) and the related K_{ASME} as the parameter in the derivation of the K_{eNB} . From this K_{eNB} the RRC protection keys and the UP protection keys are derived as described in subclause 7.2.1.

7.2.8 Key handling in handover

7.2.8.1 General

7.2.8.1.1 Access stratum

The general principle of key handling at handovers is depicted in Figure 7.2.8.1-1.

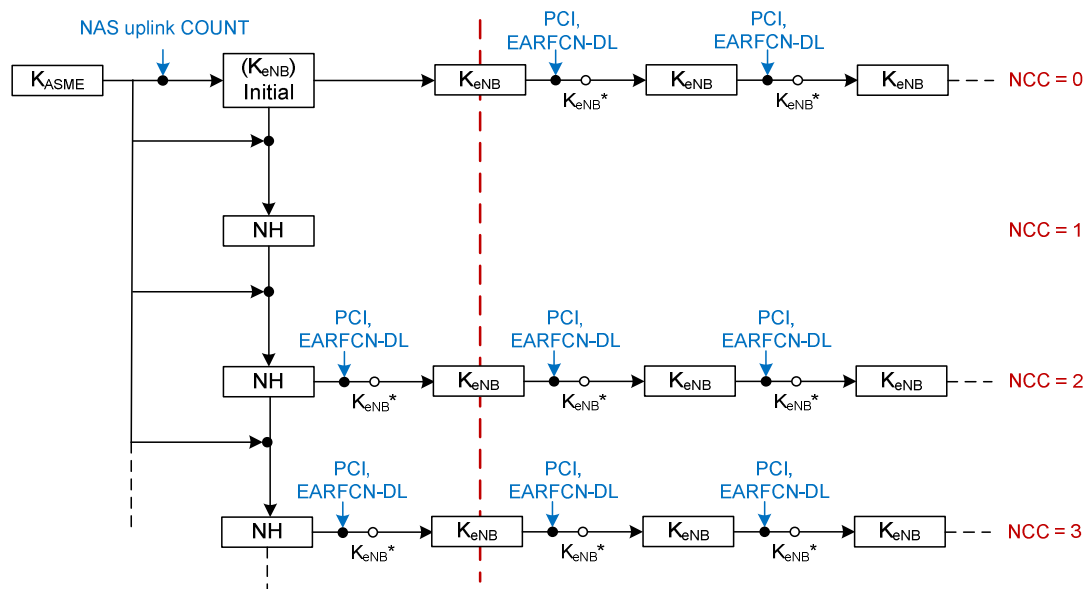

Figure 7.2.8.1-1 Model for the handover key chaining

The following is an outline of the key handling model to clarify the intended structure of the key derivations. The detailed specification is provided in subclauses 7.2.8.3 and 7.2.8.4.

Whenever an initial AS security context needs to be established between UE and eNB, MME and the UE shall derive a K_{eNB} and a Next Hop parameter (NH). The K_{eNB} and the NH are derived from the K_{ASME} . A NH Chaining Counter (NCC) is associated with each K_{eNB} and NH parameter. Every K_{eNB} is associated with the NCC corresponding to the NH value from which it was derived. At initial setup, the K_{eNB} is derived directly from K_{ASME} , and is then considered to be associated with a virtual NH parameter with NCC value equal to zero. At initial setup, the derived NH value is associated with the NCC value one.

NOTE 1: At the UE, the NH derivation associated with NCC=1 could be delayed until the first handover performing vertical key derivation.

Whether the MME sends the K_{eNB} key or the {NH, NCC} pair to the serving eNB is described in detail in subclauses 7.2.8.3 and 7.2.8.4. The MME shall not send the NH value to eNB at the initial connection setup. The eNB shall initialize the NCC value to zero after receiving S1-AP Initial Context Setup Request message.

NOTE 2: Since the MME does not send the NH value to eNB at the initial connection setup, the NH value associated with the NCC value one can not be used in the next X2 handover or the next intra-eNB handover, for the next X2 handover or the next intra-eNB handover the horizontal key derivation (see Figure 7.2.8.1-1) will apply.

NOTE 3: One of the rules specified for the MME in subclause 7.2.8.4 of this specification states that the MME always computes a fresh {NH, NCC} pair that is given to the target eNB. An implication of this is that the first {NH, NCC} pair will never be used to derive a K_{eNB} . It only serves as an initial value for the NH chain.

The UE and the eNB use the K_{eNB} to secure the communication between each other. On handovers, the basis for the K_{eNB} that will be used between the UE and the target eNB, called K_{eNB}^* , is derived from either the currently active K_{eNB} or from the NH parameter. If K_{eNB}^* is derived from the currently active K_{eNB} this is referred to as a horizontal key derivation (see Figure 7.2.8.1-1) and if the K_{eNB}^* is derived from the NH parameter the derivation is referred to as a vertical key derivation (see Figure 7.2.8.1-1). On handovers with vertical key derivation the NH is further bound to the target PCI and its frequency EARFCN-DL before it is taken into use as the K_{eNB} in the target eNB. On handovers with horizontal key derivation the currently active K_{eNB} is further bound to the target PCI and its frequency EARFCN-DL before it is taken into use as the K_{eNB} in the target eNB.

As NH parameters are only computable by the UE and the MME, it is arranged so that NH parameters are provided to eNBs from the MME in such a way that forward security can be achieved.

7.2.8.1.2 Non access stratum

A NAS aspect that needs to be considered is possible NAS algorithm change at MME change that could occur at a handover. At an eNB handover with MME relocation, there is the possibility that the source MME and the target MME do not support the same set of NAS algorithms or have different priorities regarding the use of NAS algorithms. In this case, the target MME re-derives the NAS keys from K_{ASME} using the NAS algorithm identities as input to the NAS key derivation functions (see clause A.7) and sends NAS SMC. All inputs, in particular the K_{ASME} , will be the same in the re-derivation except for the NAS algorithm identity.

In case the target MME decides to use NAS algorithms different from the ones used by the source MME, a NAS SMC including eKSI (new or current value depending on whether AKA was run or not) shall be sent from the MME to the UE.

This NAS Key and algorithm handling also applies to other MME changes e.g. TAU with MME changes.

NOTE: It is per operator's policy how to configure selection of handover types. Depending on an operator's security requirements, the operator can decide whether to have X2 or S1 handovers for a particular eNB according to the security characteristics of a particular eNB.

7.2.8.2 Void

7.2.8.3 Key derivations for context modification procedure

As outlined in subclause 7.2.8.1, whenever a fresh K_{eNB} is calculated from the K_{ASME} (as described in Annex A.3), the MME shall transfer the K_{eNB} to the serving eNB in a message modifying the security context in the eNB. The MME and the UE shall also compute the NH parameter from the K_{ASME} and the fresh K_{eNB} as described in Annex A.4 according to the rules in clause 7.2.9.2. An NCC value 1 is associated with the NH parameter derived from the fresh K_{eNB} and NCC value 0 with the K_{eNB} . The UE shall compute K_{eNB} and NH in the same way as the MME. From the newly computed K_{eNB} , the eNB and the UE shall compute the temporary K_{eNB}^* and then the final K_{eNB} from that K_{eNB}^* as described in clause 7.2.9.2.

NOTE 1: Since MME does not send the NH value to eNB in S1 UE CONTEXT MODIFICATION REQUEST, the NH value associated with the NCC value one can not be used in the next X2 handover or the next intra-eNB handover. So for the next X2 handover or the next intra-eNB handover the horizontal key derivation (see Figure 7.2.8.1-1) will apply.

NOTE 2: One of the rules specified for the MME in subclause 7.2.8.4 of this specification states that the MME always computes a fresh {NH, NCC} pair that is given to the target eNB. An implication of this is that the first {NH, NCC} pair, i.e., the one with NCC equal to 1 will never be used to derive a K_{eNB} . It only serves as an initial value for the NH chain.

NOTE 3: At the UE, the NH derivation associated with NCC=1 could be delayed until the first handover performing vertical key derivation.

7.2.8.4 Key derivations during handovers

7.2.8.4.1 Intra-eNB Handover

When the eNB decides to perform an intra-eNB handover it shall derive K_{eNB}^* as in Annex A.5 using target PCI, its frequency EARFCN-DL, and either NH or the current K_{eNB} depending on the following criteria: the eNB shall use the NH for deriving K_{eNB}^* if an unused {NH, NCC} pair is available in the eNB (this is referred to as a vertical key derivation), otherwise if no unused {NH, NCC} pair is available in the eNB, the eNB shall derive K_{eNB}^* from the current K_{eNB} (this is referred to as a horizontal key derivation).

The eNB shall use the K_{eNB}^* as the K_{eNB} after handover. The eNB shall send the NCC used for K_{eNB}^* derivation to UE in HO Command message.

NOTE: The key derivation mechanism described in this clause is also applicable to CHO defined in TS 36.300[30].

7.2.8.4.2 X2-handover

As in intra-eNB handovers, for X2 handovers the source eNB shall perform a vertical key derivation in case it has an unused {NH, NCC} pair. The source eNB shall first compute K_{eNB}^* from target PCI, its frequency EARFCN-DL, and either from currently active K_{eNB} in case of horizontal key derivation or from the NH in case of vertical key derivation as described in Annex A.5.

Next the source eNB shall forward the { K_{eNB}^* , NCC} pair to the target eNB. The target eNB shall use the received K_{eNB}^* directly as K_{eNB} to be used with the UE. The target eNB shall associate the NCC value received from source eNB with the K_{eNB} . The target eNB shall include the received NCC into the prepared HO Command message, which is sent back to the source eNB in a transparent container and forwarded to the UE by source eNB.

When the target eNB has completed the handover signaling with the UE, it shall send a S1 PATH SWITCH REQUEST to the MME. Upon reception of the S1 PATH SWITCH REQUEST, the MME shall increase its locally kept NCC value by one and compute a new fresh NH by using the K_{ASME} and its locally kept NH value as input to the function defined in Annex A.4. The MME shall then send the newly computed {NH, NCC} pair to the target eNB in the S1 PATH SWITCH REQUEST ACKNOWLEDGE message. The target eNB shall store the received {NH, NCC} pair for further handovers and remove other existing unused stored {NH, NCC} pairs if any.

NOTE 1: Because the path switch message is transmitted after the radio link handover, it can only be used to provide keying material for the next handover procedure and target eNB. Thus, for X2-handovers key separation happens only after two hops because the source eNB knows the target eNB keys. The target eNB can immediately initiate an intra-cell handover to take the new NH into use once the new NH has arrived in the S1 PATH SWITCH REQUEST ACKNOWLEDGE.

NOTE 2: The key derivation mechanism described in this clause is also applicable to CHO defined in TS 36.300[30].

7.2.8.4.3 S1-Handover

Upon reception of the HANDOVER REQUIRED message the source MME shall increase its locally kept NCC value by one and compute a fresh NH from its stored data using the function defined in Annex A.4. The source MME shall store that fresh pair and send it to the target MME in the S10 FORWARD RELOCATION REQUEST message. The S10 FORWARD RELOCATION REQUEST message shall in addition contain the K_{ASME} that is currently used to compute {NH, NCC} pairs and its corresponding eKSI.

The target MME shall store locally the {NH, NCC} pair received from the source MME.

The target MME shall then send the received {NH, NCC} pair to the target eNB within the S1 HANDOVER REQUEST.

Upon receipt of the S1 HANDOVER REQUEST from the target MME, the target eNB shall compute the K_{eNB} to be used with the UE by performing the key derivation defined in Annex A.5 with the fresh {NH, NCC} pair in the S1 HANDOVER REQUEST and the target PCI and its frequency EARFCN-DL. The target eNB shall associate the NCC

value received from MME with the K_{eNB} . The target eNB shall include the NCC value from the received {NH, NCC} pair into the HO Command to the UE and remove any existing unused stored {NH, NCC} pairs.

NOTE: The source MME may be the same as the target MME in the description in this subclause. If so the single MME performs the roles of both the source and target MME, i.e. the MME calculates and stores the fresh {NH, NCC} pair and sends this to the target eNB.

For S1-handover, the source eNB shall include AS algorithms used in the source cell (ciphering and integrity algorithms) in the source to target transparent container that shall be sent to the target eNB. The AS algorithms used by in the source cell are provided to the target eNB so that it can decipher and integrity verify the RRCReestablishmentComplete message on SRB1 in the potential RRCConnectionRe-establishment procedure.

7.2.8.4.4 UE handling

The UE behaviour is the same regardless if the handover is S1, X2 or intra-eNB. The UE behaviour is also same in case of Conditional Handover, as specified in TS 36.300 [30], i.e., the UE shall use the parameters of the selected target cell in K_{eNB}^* derivations.

If the NCC value the UE received in the HO Command message from target eNB via source eNB is equal to the NCC value associated with the currently active K_{eNB} , the UE shall derive the K_{eNB}^* from the currently active K_{eNB} and the target PCI and its frequency EARFCN-DL using the function defined in Annex A.5.

If the UE received an NCC value that was different from the NCC associated with the currently active K_{eNB} , the UE shall first synchronize the locally kept NH parameter by computing the function defined in Annex A.4 iteratively (and increasing the NCC value until it matches the NCC value received from the source eNB via the HO command message. When the NCC values match, the UE shall compute the K_{eNB}^* from the synchronized NH parameter and the target PCI and its frequency EARFCN-DL using the function defined in Annex A.5.

The UE shall use the K_{eNB}^* as the K_{eNB} when communicating with the target eNB.

7.2.9 Key-change-on-the fly

7.2.9.1 General

Key-change-on-the fly consists of re-keying or key-refresh.

Key refresh shall be possible for K_{eNB} , $K_{RRC-enc}$, $K_{RRC-int}$, K_{UP-int} , and K_{UP-enc} and shall be initiated by the eNB when a PDCP COUNTs is about to be re-used with the same Radio Bearer identity and with the same K_{eNB} . The procedure is described in clause 7.2.9.3.

Re-keying shall be possible for the K_{eNB} , $K_{RRC-enc}$, $K_{RRC-int}$, K_{UP-int} , and K_{UP-enc} . This re-keying shall be initiated by the MME when an EPS AS security context different from the currently active one shall be activated. The procedures for doing this are described in clause 7.2.9.2.

Re-keying shall be possible for $K_{NAS-enc}$ and $K_{NAS-int}$. Re-keying of $K_{NAS-enc}$ and $K_{NAS-int}$ shall be initiated by the MME when a EPS NAS security context different from the currently active one shall be activated. The procedures for doing this are described in clause 7.2.9.4.

Re-keying of the entire EPS key hierarchy including K_{ASME} shall be achieved by first re-keying K_{ASME} , then $K_{NAS-enc}$ and $K_{NAS-int}$, followed by re-keying of the K_{eNB} and derived keys. For NAS key change-on-on-the fly, activation of NAS keys is accomplished by a NAS SMC procedure.

AS Key change on-the-fly is accomplished using a procedure based on intra-cell handover. The following AS key changes on-the-fly shall be possible: local K_{eNB} refresh (performed when PDCP COUNTs are about to wrap around), K_{eNB} re-keying performed after an AKA run, activation of a native context after handover from UTRAN or GERAN.

7.2.9.2 K_{eNB} re-keying

The K_{eNB} re-keying procedure is initiated by the MME. It may be used under the following conditions:

- after a successful AKA run with the UE as part of activating a partial native EPS security context, or

- as part of re-activating a non-current full native EPS security context after handover from GERAN or UTRAN according to subclauses 9.2.2.1 and 10.3.2, or
- to create a new K_{eNB} from the current K_{ASME}

NOTE 1: To perform a key change on-the-fly of the entire key hierarchy, the MME has to change the EPS NAS security context before changing the AS security context..

In order to be able to re-key the K_{eNB} , the MME requires a fresh uplink NAS COUNT from a successful NAS SMC procedure with the UE. In the case of creating a new K_{eNB} from the current K_{ASME} a NAS SMC procedure shall be run first to provide this fresh uplink NAS COUNT. This NAS SMC procedure does not have to change other parameters in the current EPS NAS security context. The MME derives the new K_{eNB} using the key derivation function as specified in Annex A.3 using the K_{ASME} and the uplink NAS COUNT used in the most recent NAS Security Mode Complete message. The K_{eNB} is sent to the eNB in an S1 AP UE CONTEXT MODIFICATION REQUEST message triggering the eNB to perform the re-keying. The eNB runs the key-change-on-the-fly procedure with the UE. During this procedure the eNB shall indicate to the UE that a key change on-the-fly is taking place. The procedure used is based on an intra-cell handover, and hence the same K_{eNB} derivation steps shall be taken as in a normal handover procedure.

When the UE receives an indication that the procedure is a key change on-the-fly procedure, the UE shall derive a temporary K_{eNB} by applying the key derivation function as specified in Annex A.3 using the K_{ASME} from the current EPS NAS security context and the uplink NAS COUNT in the most recent NAS Security Mode Complete message.

From this temporary K_{eNB} the UE shall derive the K_{eNB}^* as normal (see clause A.5). The eNB shall take the K_{eNB} it received from the MME, which is equal to the temporary K_{eNB} , as basis for its K_{eNB}^* derivations. From this step onwards, the key derivations continue as in a normal handover.

If the AS level re-keying fails, then the MME shall complete another NAS security mode procedure before initiating a new AS level re-keying. This ensures that a fresh K_{eNB} is used.

The NH parameter shall be handled according to the following rules:

- UE and MME shall use NH derived from old K_{ASME} before the context modification is complete, i.e. for the UE when it sends the RRC Connection Reconfiguration Complete, and for the MME when it receives the UE CONTEXT MODIFICATION RESPONSE. In particular, the MME shall send an NH derived from old K_{ASME} in the S1AP HANDOVER RESOURCE ALLOCATION, S10 FORWARD RELOCATION, and S1AP PATH SWITCH REQUEST ACKNOWLEDGE messages before the context modification is complete.
- The eNB shall delete any old NH upon completion of the context modification.
- The UE and MME shall delete any old NH upon completion of the context modification. After the completion of the context modification, the UE and the MME shall derive any new NH parameters from the K_{eNB} calculated from the uplink NAS COUNT and the K_{ASME} used to calculate that K_{eNB} according to Annex A.4.

7.2.9.3 KeNB refresh

This procedure is based on an intra-cell handover. The K_{eNB} chaining that is performed during a handover ensures that the K_{eNB} is re-freshed w.r.t. the RRC and UP COUNT after the procedure.

7.2.9.4 NAS key re-keying

After an AKA has taken place, new NAS keys from a new K_{ASME} shall be derived, according to Annex A.7.

To re-activate a non-current full native EPS security context after handover from GERAN or UTRAN, cf. clause 9.2.2 B step 7, the UE and the MME take the NAS keys into use by running a NAS SMC procedure according to clause 7.2.4.5.

MME shall activate fresh NAS keys from an EPS AKA run or activate native security context with sufficiently low NAS COUNT values before the NAS uplink or downlink COUNT wraps around with the current security context.

7.2.10 Rules on Concurrent Running of Security Procedures

Concurrent runs of security procedures may, in certain situations, lead to mismatches between security contexts in the network and the UE. In order to avoid such mismatches, the following rules shall be adhered to:

1. MME shall not initiate any of the S1 procedures Initial Context Setup or UE Context Modification including a new K_{eNB} towards a UE if a NAS Security Mode Command procedure is ongoing with the UE.
2. The MME shall not initiate a NAS Security Mode Command towards a UE if one of the S1 procedures Initial Context Setup or UE Context Modification including a new K_{eNB} is ongoing with the UE.
3. When the UE has cryptographically protected radio bearers established and the MME has initiated a NAS SMC procedure in order to take a new K_{ASME} into use, the MME shall continue to include AS security context parameters based on the old K_{ASME} in the HANDOVER REQUEST or PATH SWITCH REQUEST ACKNOWLEDGE message, until the MME takes a K_{eNB} derived from the new K_{ASME} into use by means of a UE Context Modification procedure.
4. When the UE has cryptographically protected radio bearers established and has received a NAS SMC message in order to take a new K_{ASME} into use, the UE shall continue to use AS security context parameters based on the old K_{ASME} in handover until the network indicates in an RRCConnectionReconfiguration procedure to take a K_{eNB} derived from the new K_{ASME} into use.
5. The source eNB shall reject an S1 UE Context Modification Request when the eNB has initiated, but not yet completed, an inter-eNB handover. When a RRCConnectionReconfiguration procedure triggered by a UE Context Modification is ongoing the source eNB shall wait for the completion of this procedure before initiating any further handover procedure.
6. When the MME has initiated a NAS SMC procedure in order to take a new K_{ASME} into use and receives a request for an inter-MME handover or an inter-RAT handover from the serving eNB, the MME shall wait for the completion of the NAS SMC procedure before sending an S10 FORWARD RELOCATION message or initiating an inter-RAT handover.
7. When the MME has initiated a UE Context Modification procedure in order to take a new K_{eNB} into use and receives a request for an inter-MME handover from the serving eNB, the MME shall wait for the (successful or unsuccessful) completion of the UE Context Modification procedure before sending an S10 FORWARD RELOCATION message.
8. When the MME has successfully performed a NAS SMC procedure taking a new K_{ASME} into use, but has not yet successfully performed a UE Context Modification procedure, which takes a K_{eNB} derived from the new K_{ASME} into use, the MME shall include both the old K_{ASME} with the corresponding eKSI, NH, and NCC, and a full EPS NAS security context based on the new K_{ASME} in the S10 FORWARD RELOCATION message.
9. When an MME receives a S10 FORWARD RELOCATION message including both the old K_{ASME} with the corresponding eKSI, NH, and NCC, and a full EPS NAS security context based on the new K_{ASME} the MME shall use the new K_{ASME} in NAS procedures, but shall continue to include AS security context parameters based on the old K_{ASME} in the HANDOVER REQUEST or PATH SWITCH REQUEST ACKNOWLEDGE message until the completion of a UE Context Modification procedure, which takes a K_{eNB} derived from the new K_{ASME} into use.
10. Once the source MME has sent an S10 FORWARD RELOCATION message to the target MME at an inter-MME handover, the source MME shall not send any downlink NAS messages to the UE until it is aware that the handover has either failed or has been cancelled.

7.2.11 Suspend and resume of RRC connection

7.2.11.1 General

The purpose of this procedure is to allow the eNB to suspend an RRC connection to be resumed by the UE at a later time. The UE may resume the RRC connection in the same or different eNB than where the suspend took place. The UE and eNB store the AS security context at suspend and reactivate the AS security context at resume.

The UE and the eNB may also use EDT (Early Data Transmission) feature in this procedure, as defined in TS 36.331 [21].

7.2.11.2 RRC connection suspend

When the eNB initiates the RRC Connection Suspend procedure it sends S1-AP UE Context Suspend Request message to the MME. Upon reception of the S1-AP UE Context Suspend Request message the MME shall check its local policy. If the local policy indicates that a new NH derivation is needed, the MME shall increase its locally kept NCC value by one and compute a fresh NH from its stored data using the function defined in Annex A.4. The MME shall store that fresh {NH, NCC} pair and send it to the eNB in the S1-AP UE Context Suspend Response message.

Upon receipt of the S1-AP UE Context Suspend Response message from the MME and if the message includes a {NH, NCC} pair, the eNB shall store the fresh {NH, NCC} pair in the S1-AP UE Context Suspend Response message and remove any existing unused stored {NH, NCC} pairs.

The eNB shall include a Resume ID, to be used for context identification and re-establishment, in the RRC Connection Suspend message sent from the eNB to the UE. The RRC Connection Suspend message is protected in PDCP layer using the current AS security context. The eNB shall store the Resume ID together with the UE context including the AS security context. The UE ID part of the Resume ID assigned by the eNB shall be different in consecutive suspends of the same UE. This is to avoid tracking of UEs based on the Resume ID.

If the eNB has a fresh {NH, NCC} pair, the eNB shall keep K_{RRCint} and delete other keys of the AS security context, i.e. keys K_{eNB} , K_{RRCenc} , K_{UPenc} shall be deleted after sending the RRC Connection Suspend message to the UE. Otherwise, if a fresh {NH, NCC} pair was not received from the MME the eNB shall keep the AS keys.

When the UE receives the RRC Connection Suspend message from the eNB, then the UE shall store the Resume ID together with the current UE context including the AS security context until the UE decides to resume the RRC connection.

When the EDT feature is used, the subsequent handling shall apply to the RRC Connection Suspend procedure. If the eNB has a fresh and unused pair of {NH, NCC}, then the eNB shall include the fresh NCC in the RRC Connection Suspend message. The eNB shall keep the current K_{RRCint} , but delete other current AS keys K_{eNB} , K_{RRCenc} , and K_{UPenc} . Otherwise, if the eNB does not have a fresh and unused pair of {NH, NCC}, then the eNB shall include the same NCC value associated with the current K_{eNB} in the RRC Connection Suspend message. In this case, the eNB shall keep the current K_{RRCint} and the current K_{eNB} , but delete other current AS keys K_{RRCenc} , and K_{UPenc} .

When the UE receives the RRC Connection Suspend message including an NCC value, then the UE shall take the received NCC value for use in the next resume. NCC received in RRC Connection Suspend message shall only be used for initiating EDT resume.

7.2.11.3 RRC connection resume to a new eNB

When the UE decides to resume the RRC connection, the UE sends the RRC Connection Resume Request message on SRB0 and hence it is not integrity protected. The UE shall include information to be used for context identification and re-establishment in the RRC Connection Resume Request message: the Resume ID and a ShortResumeMAC-I. The ShortResumeMAC-I is a message authentication token, which shall be calculated with the following inputs: source C-RNTI, source PCI, resume constant and target Cell-ID as defined by *VarShortResumeMAC-Input* in TS 36.331 [21] and using the stored K_{RRCint} used with the source eNB where the UE was suspended.

The Resume ID was assigned to the UE in the cell where the UE was suspended (the source cell). The source PCI and source C-RNTI are associated with the cell where the UE was suspended. The target Cell-ID is the identity of the target cell where the UE sends the RRC Connection Resume Request message. The resume constant allows differentiation of *VarShortResumeMAC* from *VarShortMAC*. The integrity algorithm shall be the negotiated EIA-algorithm from the stored AS security context from the source eNB.

- KEY shall be set to K_{RRCint} of the source cell;
- all BEARER bits shall be set to 1;
- DIRECTION bit shall be set to 1;
- all COUNT bits shall be set to 1.

The ShortResumeMAC-I shall be the 16 least significant bits of the output of the used integrity algorithm.

The target eNB extracts the Resume ID and ShortResumeMAC-I from the RRC Connection Resume Request. The target eNB contacts the source eNB based on the information in the Resume ID by sending a Retrieve UE Context Request message on X2 interface including the Resume ID, the ShortResumeMAC-I and Cell-ID of target cell, in order to retrieve the UE context including the AS security context.

The source eNB retrieves the stored UE context including the AS security context from its database identified by the Resume ID and the source eNB calculates and verifies the ShortResumeMAC-I (calculating it in the same way as described above). If the check of the ShortResumeMAC-I is successful, then the source eNB shall derive a new K_{eNB}^* as described in Annex A.5 based on the target PCI and target EARFCN-DL. The source eNB can obtain the target PCI and target EARFCN-DL from a cell configuration database by means of the target Cell-ID. If the source eNB has a fresh {NH, NCC} pair from the MME then that pair shall be used and the fresh NH shall be used as in the new K_{eNB}^* derivation. The source eNB responds with a Retrieve UE Context Response message to the target eNB on X2 interface including the UE context including the AS security context. The AS security context sent to the target eNB shall include the new derived K_{eNB}^* , the NCC associated to the K_{eNB}^* , the UE EPS security capabilities including the security algorithms supported by the UE and ciphering and integrity algorithms used in the source cell. The target eNB shall check if it supports the ciphering and integrity algorithms used in the source cell. If this is not the case, the target eNB shall send an appropriate error message to the UE. If the check is successful the target eNB derives new AS keys (RRC integrity key, RRC encryption key and UP keys) corresponding to the algorithms from the received K_{eNB}^* , reset all PDCP COUNTs to 0 and activates the new keys in PDCP layer. The target eNB responds with a RRC Connection Resume message including the NCC received from source eNB to the UE on SRB1, integrity protected in PDCP layer using the new AS keys. The RRC Connection Resume message may include RRC connection reconfiguration parameters as defined in TS 36.300 [30].

When the UE receives the RRC Connection Resume message, then the UE shall check if the received NCC value is different from the current NCC value stored in the UE itself. If the NCC values differ then the UE needs to synchronize its locally kept NH as defined in Annex A.4. The UE then calculates a new K_{eNB}^* from either the new NH (if a new NCC value was received) or the current K_{eNB}^* , using the target cell's PCI and its frequency EARFCN-DL in the target cell. The UE performs then further derivation of the AS keys (RRC integrity key, RRC encryption key and UP keys) from the new derived K_{eNB}^* . The UE checks the integrity of the RRC Connection Resume message by verifying the MAC-I. If the verification of the MAC-I is successful, then the UE resets all PDCP COUNTs to 0 and activates the new AS keys in PDCP layer and then sends the RRC Connection Resume Complete message both integrity protected and ciphered to the target eNB on SRB1.

Security is fully resumed on UE side after reception and processing of RRC connection resume message. The UE can receive data on DRB(s) after having received and processed RRC connection resume message. UL data on DRB(s) can be sent after RRC Connection Resume Complete message.

After a successful resume the target eNB shall perform Path Switch procedure as is done in case of X2-handover.

When EDT feature is used, the following handling shall apply to the RRC Connection Resume procedure. For protection of the UL EDT data in the RRC Connection Resume Request message and all other RRC messages following the RRC Connection Resume Request message except RRC Connection Reject, the UE and the source eNB shall derive a new K_{eNB}^* . This new K_{eNB}^* shall be derived using the target PCI, target EARFCN-DL and the K_{eNB}/NH based on either a horizontal key derivation or a vertical key derivation (as defined in Clause 7.2.8.1.1 and Annex A.5) according to the NCC value sent to the UE in the RRC Connection Suspend message. The UE and the target eNB shall further derive new AS keys K_{RRCint} , K_{RRCenc} , and K_{UPenc} from the newly derived K_{eNB}^* . The UE and the target eNB shall use the newly derived K_{UPenc} for ciphering/deciphering of the UL EDT data in PDCP layer in the RRC Connection Resume Request message, and user DL data (if included) in PDCP layer in the RRC Connection Suspend or RRC Connection Resume message. The calculation and verification of the ShortResumeMAC-I shall use the (old) K_{RRCint} used in the source cell.

NOTE 1: Void.

NOTE 2: Void.

Further, in case of EDT, the RRC Connection Resume message sent by the target eNB to the UE shall be both integrity protected and ciphered in PDCP layer using the new AS keys (K_{RRCint} , K_{RRCenc}) derived from the new K_{eNB}^* . In this case, the UE shall ignore the NCC value in RRC Connection Resume message and shall not change its K_{eNB} . The UE may receive an RRC Connection Reject message with suspend indication, instead of RRC Connection Resume message. In that case, for the next resume to any target eNB, the UE shall start with the same AS security context as it had when it was suspended originally, i.e., same K_{eNB}/NH shall act as base key for derivation of new K_{eNB}^* .

7.2.11.4 RRC connection resume to the same eNB

The target eNB may be the same as the source eNB in the description in the previous subclause. If so the single eNB performs the roles of both the source and target eNB. In particular, a new K_{eNB}^* shall be derived even if the UE is resuming to the same cell from where it was suspended. However, there is the following difference.

After a successful resume the eNB shall send S1-AP UE Context Resume Request message to the MME. Upon reception of the S1-AP UE Context Resume Request message the MME shall check its local policy. If the local policy in the MME indicates that a new NH derivation is needed, the MME shall increase its locally kept NCC value by one and compute a fresh NH from its stored data using the function defined in Annex A.4. The MME shall store that fresh pair and send it to the eNB in the S1-AP UE Context Resume Response message.

Upon receipt of the S1-AP UE Context Resume Response message from the MME and if the message includes a {NH, NCC} pair, the eNB shall store the fresh {NH, NCC} pair in the S1-AP UE Context Resume Response message and remove any existing unused stored {NH, NCC} pairs. The {NH, NCC} pair may be used in the next suspend/resume or X2-handover procedures.

When EDT feature is used, the single eNB performs the roles of both the source and target eNB as described in Clause 7.2.11.3.

7.3 UP security mechanisms

7.3.1 UP confidentiality mechanisms

The user plane data is ciphered by the PDCP protocol between the UE and the eNB as specified in TS 36.323 [12].

The use and mode of operation of the 128-EEA algorithms are specified in Annex B.

The input parameters to the 128-bit EEA algorithms as described in Annex B are an 128-bit cipher key K_{UPenc} as KEY, a 5-bit bearer identity BEARER which value is assigned as specified by TS 36.323 [12], the 1-bit direction of transmission DIRECTION, the length of the keystream required LENGTH and a bearer specific, time and direction dependent 32-bit input COUNT which corresponds to the 32-bit PDCP COUNT.

7.3.2 UP integrity mechanisms

This subclause applies only to the user plane on the Un interface between RN and DeNB:

The user plane data is integrity-protected by the PDCP protocol between the RN and the DeNB as specified in TS 36.323 [12]. Replay protection shall be activated when integrity protection is activated. Replay protection shall ensure that the receiver only accepts each particular incoming PDCP COUNT value once using the same AS security context.

The use and mode of operation of the 128-EIA algorithms are specified in Annex B.

The input parameters to the 128-bit EIA algorithms as described in Annex B are a 128-bit integrity key K_{UPint} as KEY, a 5-bit bearer identity BEARER which value is assigned as specified by TS 36.323 [12], the 1-bit direction of transmission DIRECTION, and a bearer specific, time and direction dependent 32-bit input COUNT which corresponds to the 32-bit PDCP COUNT.

The supervision of failed UP integrity checks shall be performed both in the RN and the DeNB. In case of failed integrity check (i.e. faulty or missing MAC-I) is detected after the start of integrity protection, the concerned message shall be discarded. This can happen on the DeNB side or on the RN side.

NOTE: The handling of UP integrity check failures by an RN is an implementation issue. TS 36.323 [12] intentionally does not mandate any action for a failed integrity check (not even sending an indication of failure to higher layers). Consequently, depending on the implementation, the message failing integrity check is, or is not, silently discarded. This is in contrast to the handling of a failed RRC integrity check by a UE, cf. the NOTE in clause 7.4.1 of the present document.

7.4 RRC security mechanisms

7.4.1 RRC integrity mechanisms

RRC integrity protection shall be provided by the PDCP layer between UE and eNB and no layers below PDCP shall be integrity protected. Replay protection shall be activated when integrity protection is activated (except for when the selected integrity protection algorithm is EIA0, see Annex B). Replay protection shall ensure that the receiver only accepts each particular incoming PDCP COUNT value once using the same AS security context.

The use and mode of operation of the 128-EIA algorithms are specified in Annex B.

The input parameters to the 128-bit EIA algorithms as described in Annex B are an 128-bit integrity key K_{RRCint} as KEY, a 5-bit bearer identity BEARER which value is assigned as specified by TS 36.323 [12], the 1-bit direction of transmission DIRECTION and a bearer specific, time and direction dependent 32-bit input COUNT which corresponds to the 32-bit PDCP COUNT.

The supervision of failed RRC integrity checks shall be performed both in the ME and the eNB. In case of failed integrity check (i.e. faulty or missing MAC-I) is detected after the start of integrity protection, the concerned message shall be discarded. This can happen on the eNB side or on the ME side.

NOTE: This text does not imply that the concerned message is silently discarded. In fact, TS 36.331 [21] specifies that the UE shall trigger a recovery procedure upon detection of a failed RRC integrity check. When the cause for integrity protection failure is not a context mismatch, such as a key or HFN mismatch, the run of a recovery procedure unnecessarily adds load to the system. However, in the absence of a means for the UE to reliably detect the cause of an integrity protection failure and the fact that the only identified consequence of an active attack is limited to non-persistent DoS effects, priority was given to a procedure allowing recovery from the deadlock caused by a context mismatch.

7.4.2 RRC confidentiality mechanisms

RRC confidentiality protection is provided by the PDCP layer between UE and eNB.

The use and mode of operation of the 128-EEA algorithms are specified in Annex B.

The input parameters to the 128-bit EEA algorithms as described in Annex B are an 128-bit cipher Key K_{RRCenc} as KEY, a 5-bit bearer identity BEARER which corresponds to the radio bearer identity, the 1-bit direction of transmission DIRECTION, the length of the keystream required LENGTH and a bearer specific, time and direction dependent 32-bit input COUNT which corresponds to the 32-bit PDCP COUNT.

7.4.3 K_{eNB}^* and Token Preparation for the RRCConnectionRe-establishment Procedure

The K_{eNB}^* and token calculation at handover preparation are cell specific instead of eNB specific. At potential RRC Connection re-establishment (e.g. in handover failure case), the UE may select a cell different from the target cell to initiate the re-establishment procedure. To ensure that the UE RRCConnectionRe-establishment attempt is successful when the UE selects another cell under the control of the target eNB at handover preparation, the serving eNB could prepare multiple K_{eNB}^* s and tokens for multiple cells which are under the control of the target eNB. The serving eNB may prepare cells belonging to the serving eNB itself.

The preparation of these cells includes sending security context containing K_{eNB}^* s and tokens for each cell to be prepared, as well as the corresponding NCC, the UE EPS security capabilities, and the security algorithms used in the source cell for computing the token, to the target eNB. The source eNB shall derive the K_{eNB}^* s as described in Annex A.5 based on the corresponding target cell's physical cell ID and frequency EARFCN-DL.

In order to calculate the token, the source eNB shall use the negotiated EIA-algorithm from the AS Security context from the source eNB with the following inputs: source C-RNTI, source PCI and target Cell-ID as defined by *VarShortMAC-Input* in TS 36.331 [21], where source PCI and source C-RNTI are associated with the cell the UE last had an active RRC connection with and target Cell-ID is the identity of the target cell where the *RRCCConnectionReestablishmentRequest* is sent to.

- KEY shall be set to K_{RRCint} of the source cell;
- all BEARER bits shall be set to 1;
- DIRECTION bit shall be set to 1;
- all COUNT bits shall be set to 1.

The token shall be the 16 least significant bits of the output of the used integrity algorithm.

To avoid that the UE cannot perform the RRC re-establishment procedure if there is a failure during a handover or a connection re-establishment, the UE shall keep the K_{eNB} used in the source cell until the handover or a connection re-establishment has completed successfully or until the UE has deleted the K_{eNB} due to other rules in this specification (e.g., due to transitioning to ECM-IDLE).

For X2 handover, the target eNB shall use these received multiple K_{eNB} 's. But for S1 handover, the target eNB discards the multiple K_{eNB} 's received from the source eNB, and derives the K_{eNB} 's as described in Annex A.5 based on the received fresh {NH, NCC} pair from MME for forward security purpose.

When an *RRCCConnectionReestablishmentRequest* is initiated by the UE, the *RRCCConnectionReestablishmentRequest* shall contain the token corresponding to the cell the UE tries to reconnect to. This message is transmitted over SRB0 and hence not integrity protected.

The target eNB receiving the *RRCCConnectionReestablishmentRequest* shall respond with an *RRCCConnectionReestablishment* message containing the NCC received during the preparation phase if the token is valid, otherwise the target eNB shall reply with an *RRCCConnectionReestablishmentReject* message. The *RRCCConnectionReestablishment* and *RRCCConnectionReestablishmentReject* messages are also sent on SRB0 and hence not integrity protected. Next the target eNB and UE shall do the following: The UE shall firstly synchronize the locally kept NH parameter as defined in Annex A.4 if the received NCC value is different from the current NCC value in the UE itself. Then the UE shall derive K_{eNB} * as described in Annex A.5 based on the selected cell's physical cell ID and its frequency EARFCN-DL. The UE shall use this K_{eNB} * as K_{eNB} . The eNB uses the K_{eNB} * corresponding to the selected cell as K_{eNB} . Then, UE and eNB shall derive and activate keys for integrity protection and verification from this K_{eNB} and the AS algorithms (ciphering and integrity algorithms) obtained during handover preparation procedures which were used in source eNB. Even if the AS algorithms used by the source eNB do not match with the target eNB local algorithm priority list the source eNB selected AS algorithms shall take precedence when running the *RRCCConnectionRe-establishment* procedure. The target eNB and UE should refresh the selected AS algorithms and the AS keys based on local prioritized algorithms after the *RRCCConnectionRe-establishment* procedure.

NOTE: When the AS algorithms transferred by source eNB are not supported by the target eNB, the target eNB will fail to decipher or integrity verify the *RRCCReestablishmentComplete* message on SRB1. As a result, the *RRCCConnectionRe-establishment* procedure will fail.

The UE shall respond with an *RRCCReestablishmentComplete* on SRB1, integrity protected and ciphered using these new keys. The *RRCCConnectionReconfiguration* procedure used to re-establish the remaining radio bearers shall only include integrity protected and ciphered messages.

7.4.4 RRCCConnectionRe-establishment Procedure for Control Plane CIoT EPS optimisation

If the UE experience a RLF when using Control Plane CIoT EPS optimisation only, the AS layer of the UE may trigger an *RRCCConnectionReestablishment* procedure. As there is no AS security available, this procedure can not be protected as described in subclause 7.4.3.

In order to protect the re-establishment procedure, the AS part of the UE triggers the NAS part of the UE to provide the *UL_NAS_MAC* and *XDL_NAS_MAC*. These parameter are used to show that the UE is requesting the re-establishment and that the UE is talking to a genuine network respectively.

The UE calculates a UL_NAS_MAC and XDL_NAS_MAC by using the currently used NAS integrity algorithm with the following inputs, K_{NASint} as the key, the uplink NAS COUNT that would be used for the next uplink NAS message, the DIRECTION bit set to 0 and the target Cell-ID as the message to be protected to calculate NAS-MAC (see Annex B.2.1).

The uplink NAS COUNT is increased by the UE in exactly the same way as if it had sent a NAS message. The first 16 bits of NAS-MAC form UL_NAS_MAC and the last 16 bits form XDL_NAS_MAC, which is stored by the UE.

The UE shall send the RRCConnectionReestablishmentRequest message to the target eNB and shall include S-TMSI, the 5 least significant bits (LSB) of the NAS COUNT that was used to calculate NAS-MAC and UL_NAS_MAC in the message.

The target eNB recognises the RRCConnectionReestablishmentRequest message sent by a UE relates to the Control Plane CIoT EPS optimisation based on the presence of the S-TMSI in the message. The target eNB shall send the S-TMSI, LSB of NAS COUNT, UL_NAS_MAC and target Cell-ID in the eNB CP Relocation Indication message to the MME that is serving the UE (this can be determined by the S-TMSI).

The MME uses LSB of NAS COUNT to estimate the full uplink NAS COUNT and calculates XNAS-MAC (see Annex B.2.1) using the same inputs (i.e. estimated uplink NAS COUNT, DIRECTION bit set to 0 and the target Cell-ID as the message) as the UE used for calculating NAS-MAC. The MME then compares the received UL_NAS_MAC with the first 16 bits of XNAS-MAC and if these are equal the network is sure that the genuine UE sent the RRCConnectionReestablishmentRequest message. The stored uplink NAS COUNT in the MME is set as though the MME received a successfully protected NAS message using that NAS COUNT.

The MME shall set DL_NAS_MAC to the last 16 bits of already calculated XNAS-MAC and send DL_NAS_MAC to the target eNB in the Connection Establishment Indication message. The target eNB shall send the DL_NAS_MAC to the UE in the RRCConnectionReestablishment message. The UE shall check that the received DL_NAS_MAC equal to the stored XDL_NAS_MAC. If so, the UE shall complete the re-establishment procedure.

7.4.5 RRC UE capability transfer procedure

The network should activate AS security (i.e., perform a successful AS SMC procedure) before running the RRC UE capability transfer procedure.

With the exception of unauthenticated emergency calls and the UEs using Control plane CIoT optimization, if the network had acquired UE capabilities using RRC UE capability transfer procedure before AS security activation, then the network shall not store them locally for later use and shall not send them to other network entities. In that case, the network shall re-run the RRC UE capability transfer procedure after a successful AS SMC procedure.

NOTE 1: For UEs without AS security (e.g., UEs using Control Plane CIoT optimization), RRC UE radio capability transfer procedure cannot be protected.

7.5 Signalling procedure for periodic local authentication

The following procedure is used optionally by the eNB to periodically perform a local authentication. At the same time, the amount of data sent during the AS connection is periodically checked by the eNB and the UE for both up and down streams. If UE receives the Counter Check request, it shall respond with Counter Check Response message.

The eNB is monitoring the PDCP COUNT values associated to each radio bearer. The procedure is triggered whenever any of these values reaches a critical checking value. The granularity of these checking values and the values themselves are defined by the visited network. All messages in the procedure are integrity protected.

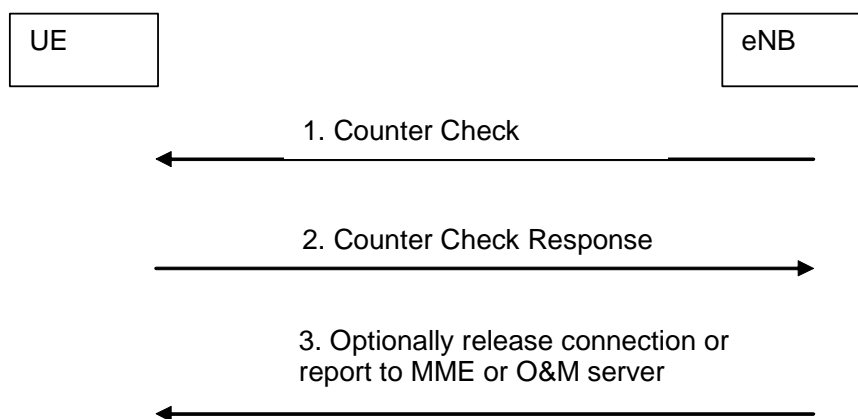

Figure 7.5-1: eNB periodic local authentication procedure

1. When a checking value is reached (e.g. the value in some fixed bit position in the hyperframe number is changed), a Counter Check message is sent by the eNB. The Counter Check message contains the most significant parts of the PDCP COUNT values (which reflect amount of data sent and received) from each active radio bearer.
2. The UE compares the PDCP COUNT values received in the Counter Check message with the values of its radio bearers. Different UE PDCP COUNT values are included within the Counter Check Response message.
3. If the eNB receives a counter check response message that does not contain any PDCP COUNT values, the procedure ends. If the eNB receives a counter check response that contains one or several PDCP COUNT values, the eNB may release the connection or report the difference of the PDCP COUNT values for the serving MME or O&M server for further traffic analysis for e.g. detecting the attacker.

8 Security mechanisms for non-access stratum signalling and data via MME

8.0 General

The statements relating to UEs in clause 8 apply also to RNs regarding the security between a relay node and its MME.

Clause 8 also applies to the security procedures for data sent via the MME.

8.1 NAS integrity mechanisms

Integrity protection for NAS signalling messages shall be provided as part of the NAS protocol.

8.1.1 NAS input parameters and mechanism

Input parameters to the NAS 128-bit integrity algorithms as described in Annex B are an 128-bit integrity key K_{NASint} as KEY, an 5-bit bearer identity BEARER which shall equal the constant value 0x00, the direction of transmission DIRECTION, and a bearer specific, time and direction dependent 32-bit input COUNT which is constructed as follows:

COUNT := 0x00 || NAS OVERFLOW || NAS SQN

Where

- the leftmost 8 bits are padding bits including all zeros.
- NAS OVERFLOW is a 16-bit value which is incremented each time the NAS SQN is incremented from the maximum value.

- NAS SQN is the 8-bit sequence number carried within each NAS message.

NOTE: The BEARER identity is not necessary since there is only one NAS signalling connection per pair of MME and UE, but is included as a constant value so that the input parameters for AS and NAS will be the same, which simplifies specification and implementation work.

The use and mode of operation of the 128-bit integrity algorithms are specified in Annex B.

The supervision of failed NAS integrity checks shall be performed both in the ME and the MME. In case of failed integrity check (i.e. faulty or missing NAS-MAC) is detected after the start of NAS integrity protection, the concerned message shall be discarded except for some NAS messages specified in TS 24.301 [9]. For those exceptions the MME shall take the actions specified in TS 24.301 [9] when receiving a NAS message with faulty or missing NAS-MAC. Discarding NAS messages can happen on the MME side or on the ME side.

8.1.2 NAS integrity activation

NAS integrity shall be activated using the NAS SMC procedure or after a handover to E-UTRAN from UTRAN/GERAN. Replay protection shall be activated when integrity protection is activated (except for when the selected integrity protection algorithm is EIA0, see Annex B). Replay protection shall ensure that the receiver only accepts each particular incoming NAS COUNT value once using the same NAS security context. Once NAS integrity has been activated, NAS messages without integrity protection shall not be accepted by the UE or MME. Before NAS integrity has been activated, NAS messages without integrity protection shall only be accepted by the UE or MME in certain cases where it is not possible to apply integrity protection as specified in TS 24.301 [9]. While some NAS messages such as reject messages need to be accepted by the UE without integrity protection, the MME shall only send a reject message that causes the CSG list on the UE to be modified after the start of NAS security. The UE shall discard any message modifying the CSG list if it is not integrity protected.

NAS integrity stays activated until the EPS security context is deleted in either the UE or MME. In particular the NAS service request shall always be integrity protected and the NAS attach request message shall be integrity protected if the EPS security context is not deleted while UE is in EMM-DEREGISTERED. The length of the NAS-MAC is 32 bit. The full NAS-MAC shall be appended to all integrity protected messages except for the NAS service request. Only the 16 least significant bits of the 32 bit NAS-MAC shall be appended to the NAS service request message.

The use and mode of operation of the 128-EIA algorithms are specified in Annex B.

8.2 NAS confidentiality mechanisms

The input parameters for the NAS 128-bit ciphering algorithms shall be the same as the ones used for NAS integrity protection as described in clause 8.1, with the exception that a different key, K_{NASenc} , is used as KEY, and there is an additional input parameter, namely the length of the key stream to be generated by the encryption algorithms.

If UE in EMM-IDLE mode uses Control Plane CIoT EPS optimisation for data transport, an initial plain NAS message including user data needs to be partially ciphered (see subclause 4.4.5 of TS 24.301 [9]) with the same encryption algorithm that was agreed during the NAS SMC exchange. In this case the length of the key stream is set to the length of the part of the initial plain NAS message that is to be ciphered.

The use and mode of operation of the 128-bit ciphering algorithms are specified in Annex B.

NOTE: In the context of the present subclause, a message is considered ciphered also when the NULL encryption algorithm EEA0 is applied.

9 Security interworking between E-UTRAN and UTRAN

9.1 RAU and TAU procedures

9.1.1 RAU procedures in UTRAN

This subclause covers both the cases of idle mode mobility from E-UTRAN to UTRAN and of Idle Mode Signaling Reduction (ISR), as defined in TS 23.401 [2].

NOTE 1: TS 23.401 states conditions under which a valid P-TMSI or a P-TMSI that is mapped from a valid GUTI ("mapped GUTI") is inserted in the Information Element "old P-TMSI" in the Routing Area Update Request. It depends on the old P-TMSI which security context can be taken into use after completion of the Routing Area Update procedure.

Use of an existing UMTS security context

If the UE sends the RAU Request with the "old P-TMSI" Information Element including a valid P-TMSI it shall also include the KSI relating to this P-TMSI. This KSI is associated with the UMTS security context stored on the UE, and it indicates this fact to the SGSN. In this case the UE shall include P-TMSI signature into the RAU Request if a P-TMSI signature was assigned by the old SGSN. If the network does not have a valid security context for this KSI it shall run AKA. In case of an SGSN change keys from the old SGSN shall overwrite keys in the new SGSN if any.

NOTE 2: if the UE has a valid UMTS security context then this context is stored on the USIM according to TS 33.102 [4].

Mapping of EPS security context to UMTS security context

If the UE sends the RAU Request with the "old P-TMSI" Information Element including mapped GUTI it shall also include the KSI equal to the value of the eKSI associated with the current EPS security context (cf. clause 3). The UE shall include a truncated NAS-token, as defined in this clause further below, into the P-TMSI signature IE. The MME shall transfer UE's UTRAN and GERAN security capabilities and CK' || IK' with KSI equal to the value of the eKSI associated with the current EPS security context to SGSN with Context Response/SGSN Context Response message. The MME and UE shall derive CK' and IK' from the K_{ASME} and the NAS uplink COUNT value corresponding to the truncated NAS-token received by the MME from SGSN as specified in clause A.13. Keys CK' and IK' and KSI sent from the MME shall replace all the UTRAN PS key parameters CK, IK, s KSI in the target SGSN if any. Keys CK' and IK' and the KSI shall replace all the currently stored UTRAN PS key parameters CK, IK, KSI values on both USIM and ME. The handling of $START_{PS}$ shall comply with the rules in 3GPP TS 25.331 [24]. The UE may set the $START_{PS}$ value to 0 if it is done before establishment of the RRC connection.

The ME shall use CK' and IK' to derive the GPRS Kc using the c3 function specified in 3GPP TS 33.102 [4]. The ME shall assign the eKSI value (associated with CK' and IK') to the GPRS CKSN. The ME shall update the USIM and ME with the new GPRS Kc and GPRS CKSN.

NOTE 3: The new derived security context (including CK' and IK') replacing the old stored values in the USIM is for allowing to reuse the derived security context without invoking the authentication procedure in the subsequent connection set-ups, and also for avoiding that one KSI indicates to two different key sets and consequently leads to security context desynchronization.

NOTE 4: An operator concerned about the security of keys received from another operator may want to enforce a policy in SGSN to run a UMTS AKA as soon as possible after the run of an idle mode mobility procedure. An example of ensuring this is the deletion of the mapped UMTS security context in the SGSN after the completion of the idle mode mobility procedure.

NOTE 5: Due to replacing all the UTRAN PS key parameters CK, IK, KSI with CK', IK' and eKSI on USIM and in ME, a new GPRS Kc needs to be derived from the new UTRAN PS key parameters CK and IK (i.e. CK' and IK'), which is part of the new UMTS security context as well, as any old GPRS Kc stored on USIM and in ME belongs to an old UMTS security context and can no longer be taken into use.

SGSN shall include the allowed security algorithm and transfer them to RNC. An SMC shall be sent to the UE containing the selected algorithms.

The 16 least significant bits available in the P-TMSI signature field shall be filled with the truncated NAS-token according to 3GPP TS 23.003 [3]. The truncated NAS-token is defined as the 16 least significant bits of the NAS-token.

The NAS-token is derived as specified in Annex A.9. The UE shall use the uplink NAS COUNT value that it would use in the next NAS message to calculate the NAS-token and increase the stored uplink NAS COUNT value by 1.

SGSN shall forward the P-TMSI signature including the truncated NAS token to the old MME, which compares the received bits of the truncated NAS-token with the corresponding bits of a NAS-token generated in the MME, for the UE identified within the context request. If they match, the context request message is authenticated and authorized and MME shall provide the needed information for the SGSN. Old MME shall respond with an appropriate error cause if it does not match the value stored in the old MME. This should initiate the security functions in the new SGSN.

To avoid possible race condition problems, the MME shall compare the received truncated NAS-token with the 16 least significant bits of NAS-tokens generated from the current NAS uplink COUNT value up to current NAS uplink COUNT value +L, i.e. the interval [current NAS uplink COUNT, current NAS uplink COUNT+L]. A suitable value for the parameter L can be configured by the network operator. MME shall not accept the same NAS-token for the same UE twice except in retransmission cases happening for the same mobility event. If the MME finds a match, it shall set the stored uplink NAS COUNT value as though it had successfully received an integrity protected NAS message with the uplink NAS COUNT value that created the match.

9.1.2 TAU procedures in E-UTRAN

This subclause covers both the cases of idle mode mobility from UTRAN to E-UTRAN and of Idle Mode Signaling Reduction, as defined in TS 23.401 [2].

The TAU Request and ATTACH Request message shall include the UE security capabilities. The MME shall store these UE security capabilities for future use. The MME shall not make use of any UE security capabilities received from the SGSN.

In this procedure, the START values shall be kept in the volatile memory of the ME, cf. also clause 6.8.11 of TS 33.102 [4].

NOTE 1: TS 23.401 states conditions under which a valid GUTI or a GUTI that is mapped from a valid P-TMSI is inserted in the Information Element "old GUTI" in the Tracking Area Update Request. The value in the "old" GUTI IE informs the MME, which SGSN/MME to fetch the UE context from.

Case 1: P-TMSI not included in "old GUTI" IE in TAU Request

This case is identical to that described in clause 7.2.7.

Case 2: Mapped P-TMSI included in "old GUTI" IE in TAU Request

The UE shall include in the TAU Request:

- the KSI with corresponding P-TMSI and old RAI to point to the right source SGSN and key set there. This allows the UE and MME to generate the mapped EPS NAS security context, as described below, if current EPS NAS security context is not available in the UE and network. The KSI shall correspond to the set of keys most recently generated (either by a successful UMTS AKA run in UTRAN (which may or may not yet have been taken into use by the UE and SGSN) or a UMTS security context mapped from an EPS NAS security context during a previous visit in UTRAN).
- a P-TMSI signature, if the UE was previously connected to UTRAN where the SGSN assigned a P-TMSI signature to the UE
- a 32bit NONCE_{UE} (see clause A.11 for requirements on the randomness of NONCE_{UE}).

If the UE has a current EPS NAS security context, then it shall include the corresponding eKSI value and if it exists, the corresponding GUTI, in the TAU Request. If the UE includes the eKSI, but not the corresponding GUTI, the MME may treat the TAU request as if the EPS NAS security context did not exist. The TAU Request shall be integrity-protected, but not confidentiality-protected. The UE shall use the current EPS NAS security context algorithms to protect the TAU Request message.

NOTE 2: The current EPS NAS security context may be of type "mapped", and hence the value of the eKSI be of type "KSI_{SGSN}". This value of KSI_{SGSN} may be different from the KSI pointing to the set of keys most recently generated in UTRAN as an UMTS AKA run may have happened in UTRAN after the current mapped EPS NAS security context indicated by the eKSI with the value KSI_{SGSN} was generated

NOTE 3: The UE has a current EPS NAS security context in the following scenario: a UE established a current EPS NAS security context during a previous visit to EPS, then moves to UTRAN/GERAN from E-UTRAN and storing the current EPS NAS security context. When the UE moves back to E-UTRAN there is a current EPS NAS security context.

If a current EPS NAS security context is not available in the UE, the UE shall send the TAU request unprotected.

If the MME received a P-TMSI signature from the UE, the MME shall include that P-TMSI signature in the Context Request message sent to the SGSN. The SGSN shall transfer CK || IK to MME in the Context Response/SGSN Context Response message. In case the MM context in the Context Response/SGSN Context Response indicates GSM security mode, the MME shall abort the procedure.

In case the TAU Request was protected and the MME has the indicated EPS NAS security context it shall verify the TAU Request message. If it is successful, the UE and the MME share a current EPS NAS security context. In case the TAU Request had the active flag set or the MME chooses to establish radio bearers when there is pending downlink UP data or pending downlink signalling, K_{eNB} is calculated as described in clause 7.2.7.

If the MME wants to change the algorithms, the MME shall use a NAS security mode procedure (see clause 7.2.4.4).

If the MME does not have the EPS NAS security context indicated by the eKSI by the UE in the TAU request, or the TAU request was received unprotected, the MME shall create a new mapped EPS NAS security context (that shall become the current EPS NAS security context). In this case, the MME shall generate a 32bit NONCE_{MME} (see clause A.10 for requirements on the randomness of NONCE_{MME}), and use the received NONCE_{UE} with the NONCE_{MME} to generate a fresh mapped K'_{ASME} from CK and IK, where CK, IK were identified by the KSI and P-TMSI in the TAU Request. See Annex A.11 for more information on how to derive the fresh K'_{ASME} . The MME initiates a NAS Security mode command procedure with the UE as described in clause 7.2.4.4 including the KSI_{SGSN}, NONCE_{UE}, and NONCE_{MME} in the NAS Security mode command. The uplink and downlink NAS COUNT for mapped EPS NAS security context shall be set to start value (i.e., 0) when new mapped EPS NAS security context is created in UE and MME.

If the TAU Request had the active flag set or the MME chooses to establish radio bearers when there is pending downlink UP data or pending downlink signalling, the uplink NAS Count which is set to zero shall be used to derive the K_{eNB} in MME and UE as specified in clause A.3. MME shall deliver the K_{eNB} to the target eNB on the S1 interface.

The TAU Accept shall be protected using the current EPS NAS security context.

9.2 Handover

9.2.1 From E-UTRAN to UTRAN

NAS and AS security shall always be activated before handover from E-UTRAN to UTRAN can take place. Consequently the source system in the handover shall always send a key set to the target system during handover. The security policy of the target PLMN determines the selected algorithms to be used within the UTRAN HO command.

NOTE : The security activation in target system is not the same as handover within E-UTRAN. Only the ciphering algorithm is indicated within the UTRAN HO command. The confidentiality protection begins immediately upon UE reception of the UTRAN HO command while the integrity protection in UTRAN is activated by SMC procedure following the handover from E-UTRAN to UTRAN. Further details are in 3GPP TS 25.331 [24].

The MME shall select the current NAS downlink COUNT value to use in the handover and then increase the stored NAS downlink COUNT value by 1.

NOTE 0: Increasing the NAS downlink COUNT by 1 is to ensure that a fresh NAS downlink COUNT is used for any future purposes.

UE and MME shall derive a confidentiality key CK', and an integrity key IK' from the K_{ASME} and the selected NAS downlink COUNT value of the current EPS key security context with the help of a one-way key derivation function KDF as specified in clause A.8.

Whether UTRAN PS key ciphering is considered active in the target UTRAN after handover from E-UTRAN shall be determined according to the principles for handover to UTRAN in TS 25.331 [24].

UE and MME shall assign the value of eKSI to KSI. MME shall transfer CK' || IK' with KSI to SGSN. The target SGSN shall replace all stored parameters CK, IK, KSI, if any, with CK', IK', KSI received from the MME. The UE shall replace all stored parameters CK, IK, KSI, if any, with CK', IK', KSI in both ME and USIM. START_{PS} shall comply with the rules in 3GPP TS 25.331 [24]. The ME shall use CK' and IK' to derive the GPRS Kc using the c3 function specified in 3GPP TS 33.102 [4]. The ME shall assign the eKSI value (associated with CK' and IK') to the GPRS CKSN. The ME shall update the USIM and ME with the GPRS Kc and GPRS CKSN.

NOTE 1: The new mapped UMTS security context (including CK', and IK') replacing the stored values in the USIM and ME, is for allowing to reuse the mapped UMTS security context without invoking the authentication procedure in subsequent connection set-ups, and also for avoiding that one KSI value gets associated with two different key sets and consequently leads to UMTS security context desynchronization.

NOTE 2: An operator concerned about the security of keys received from an E-UTRAN of another operator may want to enforce a policy in SGSN to run a UMTS AKA as soon as possible after the handover. One example of ensuring this is the deletion of the mapped UMTS security context in the SGSN after the UE has left active state in UMTS.

NOTE 3: Due to replacing all the UTRAN PS key parameters CK, IK, KSI with CK', IK' and eKSI on USIM and in ME, a new GPRS Kc needs to be derived from the new UTRAN PS key parameters CK and IK (i.e. CK' and IK'), which is part of the new UMTS security context as well, as any old GPRS Kc stored on USIM and in ME, belongs to an old UMTS security context and can no longer be taken into use.

After HO from E-UTRAN to UTRAN the current EPS NAS security context shall (if it is kept) be considered as the current one in E-UTRAN in the UE and the MME.

MME shall also provide at least the 4 LSB of the selected NAS downlink COUNT value to the source eNB, which then shall include the bits in the MobilityFromE-UTRANCommand to the UE. The UE shall use the received 4 LSB and its stored NAS downlink COUNT to estimate the NAS downlink COUNT selected by the MME.

NOTE 4: It is left to the implementation how to estimate the NAS downlink COUNT.

The UE shall ensure that the estimated NAS downlink COUNT has not been used to calculate a CK' and IK' in a previous successful or unsuccessful PS or SRVCC handover. If the estimated NAS downlink COUNT is greater than all the estimated NAS downlink COUNTs either used by the UE for key derivation in a handover or received in a NAS message that passed its integrity check, the UE shall update its stored NAS downlink COUNT as though it has successfully integrity checked a NAS message with that estimated NAS downlink COUNT. In particular, the stored NAS downlink COUNT shall never be decreased.

MME shall transfer the UE security capabilities to the SGSN. The selection of the algorithms in the target system proceeds as described in TS 33.102 [4] for UTRAN.

If the handover is not completed successfully, the new mapped UMTS security context can not be used in the future. The SGSN shall delete the new mapped UMTS security context and the stored UMTS security context which has the same KSI as the new mapped UMTS security context.

9.2.2 From UTRAN to E-UTRAN

9.2.2.1 Procedure

The procedure for handover from UTRAN to E-UTRAN, as far as relevant for security, proceeds in the following two consecutive steps:

A) Handover signalling using the mapped EPS security context (cf. also Figure 9.2.2.1-1);

B) Subsequent NAS signalling to determine whether a native EPS security context can be taken in use (not shown in Figure 9.2.2.1-1).

In this procedure, the START values shall be kept in the volatile memory of the ME, cf. also clause 6.8.11 of TS 33.102 [4].

The activation of NAS and AS security in E-UTRAN, and selection of the key set from the source system for the handover shall be according to following principles:

- i) As described for inter-SGSN PS handover cases in TS 33.102 [4], the source SGSN shall select the key set most recently generated (either by a successful UMTS AKA run in UTRAN (which may or may not yet have been taken into use by the UE and SGSN) or a UMTS security context mapped from an EPS security context during a previous visit to UTRAN) and transfer this key set to the MME in the Forward Relocation Request.

NOTE 0: The MME is considered as a target SGSN in case of Gn/Gp interface.

- ii) Activation of AS security (for details cf. TS 36.331 [21]):

The E-UTRAN HO command received at the UE shall activate AS security.

The HO Complete received at the eNB shall activate AS security.

- iii) Activation of NAS security (for details cf. TS 24.301 [9]):

The E-UTRAN HO command received at the UE shall activate NAS security.

The HO Notify received at the MME shall activate NAS security. In case the MME does not have the UE security capabilities stored from a previous visit, then no NAS message shall be sent or accepted by the MME other than a TAU request before a successful check of the UE security capabilities in the TAU request was performed by the MME.

- iv) Both AS and NAS ciphering and integrity protection algorithms shall be selected according to the policy of the target PLMN.

The above four principles consequentially always activate ciphering (potentially NULL ciphering) in E-UTRAN even if it was not active in the source system.

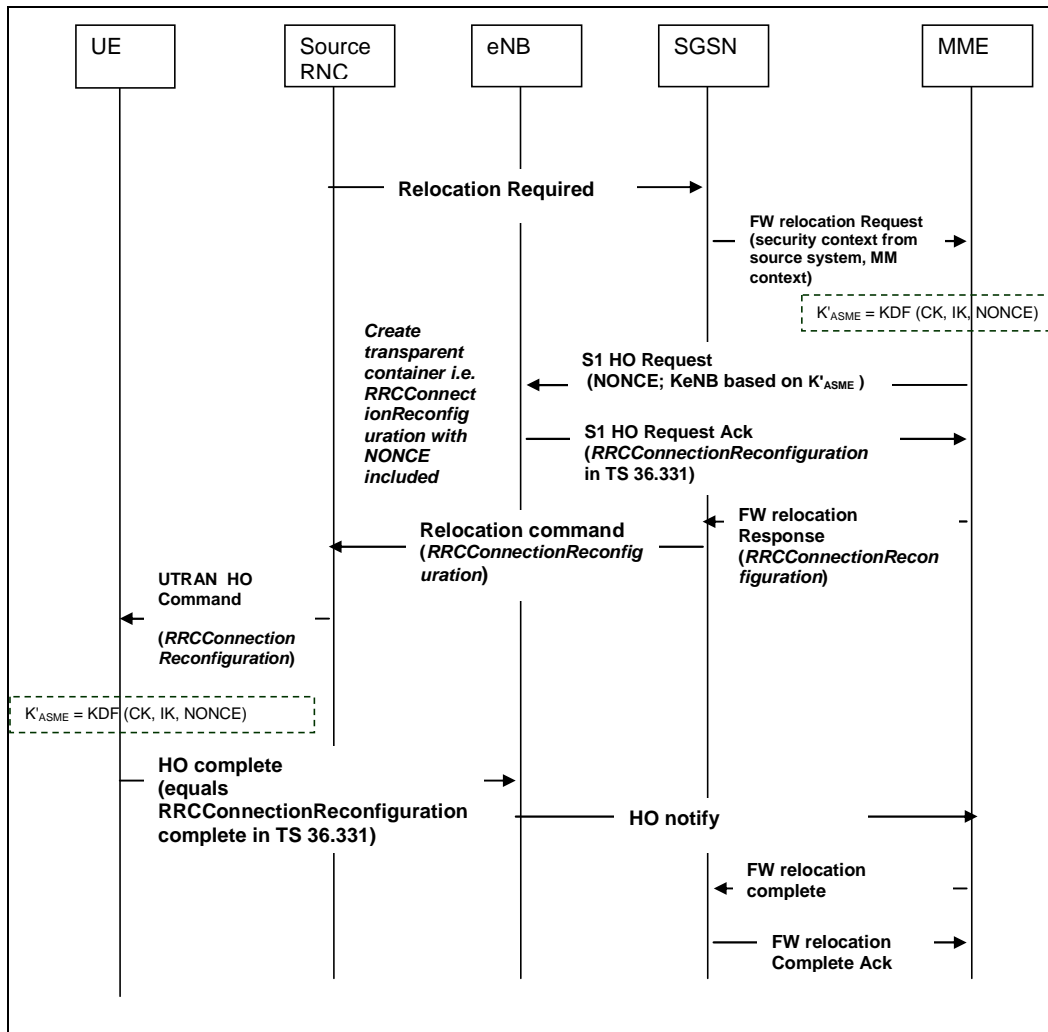

Figure 9.2.2.1-1: Handover from UTRAN to E-UTRAN

A) Handover signalling in case of successful handover

Before attempting a handover for a UE, the source RNC may check if the UE is authenticated using UMTS AKA. If the UE is not authenticated using UMTS AKA and the UE does not have an ongoing emergency call, then the source RNC may decide not to perform a handover to E-UTRAN (to avoid triggering unnecessary handover attempts to E-UTRAN which will be rejected by the target MME). The check can be performed by analysing the active CK and IK as follows:

- If the 64 most significant bits of the CK are not identical to the 64 least significant bits of the CK, the RNC can deduce that the UE was authenticated via UMTS AKA. (The bits are identical if the CK is derived from a Kc via the c4 key conversion function [4], and it is very unlikely that they are equal for a CK derived from UMTS AKA.)
- If the 64 most significant bits of the CK are identical to the 64 list significant bits of the CK, the RNC can further check if the IK fulfils the equation given by the c5 key conversion function [4]. If the IK does not fulfil this equation, the RNC can deduce that the UE was authenticated with UMTS AKA, and if the IK does, then the RNC can deduce that the UE was authenticated using GSM AKA.

If the source RNC does not conclude that the UE is authenticated using UMTS AKA, the source RNC may select an appropriate network for the UE at the handover decision stage and may send a Relocation Required message to the SGSN. This message does not contain any security-relevant parameters.

1. The SGSN shall transfer MM context (including CK and IK (or the Kc), KSI and the UE security capabilities) to MME in the Forward relocation request message. In case the MM context in the Forward relocation request message indicates GSM security mode(i.e., it contains a Kc), the MME shall abort the non-emergency call procedure. The UE security capabilities, including the UE EPS security capabilities, were sent by the UE to the SGSN via the UE Network Capability IE, in Attach Request and RAU Request. It is possible that an SGSN

does not forward the UE EPS security capabilities to the MME. When the MME does not receive UE EPS security capabilities from the SGSN, the MME shall assume that the following default set of EPS security algorithms is supported by the UE (and shall set the UE EPS security capabilities in the mapped EPS NAS security context according to this default set):

- a. EEA0, 128-EEA1 and 128-EEA2 for NAS signalling ciphering, RRC signalling ciphering and UP ciphering;
- b. 128-EIA1 and 128-EIA2 for NAS signalling integrity protection and RRC signalling integrity protection.

NOTE 1: When an EPS algorithm is specified which is not part of the default set, the MME cannot assume that a UE handing over from GERAN/UTRAN to E-UTRAN will support that algorithm in the case that the SGSN does not support transfer of the UE's EPS security capabilities to the MME. In this case the MME will select one of the algorithms from the default set instead at handover, and can then switch to the algorithm that is not part of the default set after the MME has received the UE EPS security capabilities from the UE in the Tracking Area Update request. If the operator requires that an algorithm that is not part of the default set has to be taken into use immediately after handover from GERAN/UTRAN to E-UTRAN, then the operator has to upgrade the SGSNs to support transfer of the UE EPS security capabilities to the MME.

NOTE 1a: If the UE has an unauthenticated IMS Emergency Service without integrity protection ongoing before the IRAT handover to LTE, the SGSN must be Rel-9 + and thus be able to forward the UE EPS security capabilities including EIA0 to the MME. In this case the MME would select EIA0 algorithm.

2. The MME shall create a $\text{NONCE}_{\text{MME}}$ to be used in the K'_{ASME} derivation (see clause A.10 for requirements on the randomness of $\text{NONCE}_{\text{MME}}$). MME shall derive K'_{ASME} from CK and IK with the help of a one-way key derivation function as defined in clause A.10 and associate it with a Key Set Identifier KSI_{SGSN} . The value field of the KSI_{SGSN} shall be derived by assigning the KSI corresponding to the set of keys most recently generated (either by a successful UMTS AKA run in UTRAN (which may or may not yet have been taken into use by the UE and the SGSN) or a UMTS security context mapped from an EPS security context during a previous visit in UTRAN). MME shall derive K_{eNB} from K'_{ASME} using the key derivation function defined in clause A.3. The uplink and downlink NAS COUNT values for the mapped EPS security context shall be set to start value (i.e. 0) in the MME.
3. MME shall select the NAS security algorithms (including ciphering and integrity protection) which have the highest priority from its configured list and are also present in the UE EPS security capabilities, MME shall derive the NAS keys from K'_{ASME} using the algorithm types and algorithm IDs as input to the NAS key derivation functions (see Annex A.7), MME shall include KSI_{SGSN} , $\text{NONCE}_{\text{MME}}$, the selected NAS security algorithms in the NAS Security Transparent Container IE of S1 HO Request message to the target eNB. MME further shall include K_{eNB} and the UE EPS security capabilities, either the capabilities received from the SGSN or, in the absence of these, the default set of EPS security algorithms, in the S1 HO Request message to the target eNB.
4. The target eNB shall select the AS algorithms (including ciphering for both RRC and UP, and integrity protection for RRC) which have the highest priority from its configured list and is also present in the UE EPS security capabilities. The target eNB shall create a transparent container (RRCConnectionReconfiguration) including the selected RRC, UP algorithms and the NAS Security Transparent Container IE, and send it in the S1 HO Request Ack message towards the MME. The eNB shall derive the RRC and UP from K_{eNB} using the key derivation function defined in clause A.7.

NOTE 2: This transparent container is not protected by the target eNB.

5. MME shall include the transparent container received from the target eNB in the FW Relocation Response message sent to SGSN.
6. SGSN shall include the transparent container in the relocation command sent to the RNC.
7. The RNC shall include the transparent container in the UTRAN HO command sent to the UE.

NOTE 3: The UTRAN HO command is integrity protected and optionally ciphered as specified by TS 33.102 [4].

8. The UE shall derive K'_{ASME} , associate it with KSI_{SGSN} and derive K_{eNB} in the same way the MME did in step 2. The UE shall also derive the NAS key as the MME did in step 3 and the RRC and UP keys as the eNB did in

step 4. The UE shall send a RRCConnectionReconfiguration Complete messages to the eNB. The uplink and downlink NAS COUNT values for the mapped EPS security context shall be set to start value (i.e. 0) in the UE.

9. The mapped EPS security context shall become the current (cf. subclause 3.1) EPS security context at AS and NAS level and overwrite any existing current mapped EPS security context. If the current EPS security context is of type native, then it shall become the non-current native EPS security context and overwrite any existing non-current EPS security context. The HO Complete messages and all following AS messages in E-UTRAN shall be ciphered and integrity protected according to the policy of the target PLMN.

If the handover is not completed successfully, the new mapped EPS security context can not be used in the future. The MME shall delete the new mapped EPS security context.

B) Subsequent NAS signalling

In order to prevent that successful bidding down on the UE security capabilities in a previous RAT have an effect on the selection of EPS security algorithm for NAS and AS, the UE security capabilities shall be included in the TAU request after IRAT-HO and be verified by the MME.

NOTE 4: Any TAU request following the handover will be integrity protected. Details are described in subclause 9.2.2.1

In any case UE security capability information received from the UE overwrites any capabilities received with the context transfer as specified in TS 23.401 [2].

It can happen that the MME receives different UE EPS security capabilities in the TAU Request from the already stored UE EPS security capabilities in MME (received from the source SGSN or the default UE EPS security capabilities when MME uses the default set of EPS security algorithms for the UE according to A) step 1 above). If it happens, the MME shall perform as follows:

- In case the TAU Request contains a higher priority NAS algorithm (according to the priority list stored in the MME), the MME run a NAS security mode command procedure to change the NAS algorithms according to subclause 7.2.4.4.
- MME shall send an S1 CONTEXT MODIFICATION REQUEST message to inform the eNB about the correct UE EPS security capabilities.

The eNB shall trigger a change of AS algorithms if the received UE EPS security capabilities from the S1 CONTEXT MODIFICATION REQUEST message would contain higher priority AS algorithm (according to the priority list stored in the eNB).

- 1 If the MME has native security context for the UE and does not receive a TAU request within a certain period after the HO it shall assume that UE and MME share a native security context.

NOTE 5: A TAU procedure following handover from UTRAN to E-UTRAN is mandatory if the Tracking Area has changed, but optional otherwise, cf. TS 23.401[2].

- 2 When the UE sends a TAU request it shall protect the request using the mapped EPS security context identified by KSI_{SGSN} . The UE shall also include KSI_{ASME} in the TAU request if and only if it has native EPS security context. The KSI_{ASME} shall be accompanied by a GUTI. When the MME receives a TAU request with a KSI_{ASME} and GUTI corresponding to the non-current native EPS security context stored on that MME it knows that UE and MME share a non-current native EPS security context.
- 3 Void.
- 4 When the MME receives a TAU request without a KSI_{ASME} it shall delete any non-current native EPS security context for any GUTI it may have for the user who sent the TAU request.
- 5 If the MME shares the non-current native EPS security context indexed by the KSI_{ASME} and GUTI from the TAU Request with the UE, the MME may run a NAS security mode command procedure with the UE to activate the non-current native EPS NAS security context according to clause 7.2.9.4. The MME may in addition change the K_{eNB} on the fly according to clause 7.2.9.2. In case the GUTI received in the TAU Request message pointed to a different MME, the allocation of a new GUTI, replacing the received GUTI, and the association of this new GUTI with KSI_{ASME} is required.

6 Void.

NOTE 6: The TAU Request is integrity protected with the mapped EPS security context even if the UE and the MME share a non-current native EPS security context since the UE cannot know for sure if the MME still has the non-current native EPS security context at the time of sending the TAU Request.

- 7 When the MME knows, after having completed the TAU procedure in the preceding steps, that it shares a non-current native EPS security context with the UE, the MME may (depending on configured policy and if the MME did not do it already in step 5) activate this non-current native EPS security context. This activation may occur in three ways:
- a When the UE has cryptographically protected radio bearers established: the MME shall initiate a key change on the fly procedure according to subclause 7.2.9 for the entire EPS key hierarchy.
 - b After the next transition to ECM-IDLE state following the handover from UTRAN: Upon receiving the first message from the UE after the UE has gone to ECM-IDLE state the MME shall use the procedures defined in subclauses 7.2.4.4 and 7.2.4.5 to activate the non-current native EPS security context if such exists.
 - c At the next transition to EMM-DEREGISTERED (see clause 7.2.5.1).
- 8 If a non-current native EPS security context has been established, then the UE and the MME shall delete the mapped EPS security context and set the non-current native EPS security context to the current EPS security context.
- 9 If the SN id changed during the IRAT handover, the MME shall delay authenticating the UE until after the network has concluded that the UE has received the TAU Accept message which contains the current SN id. Doing this ensures that the UE and the MME use the same SN id in the KASME derivation.

NOTE 7: The run of a NAS SMC procedure ensures that the uplink NAS COUNT has increased since the last time a K_{eNB} was derived from the K_{ASME} .

NOTE 8: For the handling of native and mapped EPS NAS security contexts after a state transition to EMM-DEREGISTERED cf. subclause 7.2.5.1.

9.2.2.2 Derivation of NAS keys and K_{eNB} during Handover from UTRAN to E-UTRAN

MME and UE shall derive the NAS keys from the mapped key K'_{ASME} as specified in clause A.7.

The MME and UE shall derive K_{eNB} by applying the KDF defined in Annex A.3 using the mapped key K'_{ASME} and $2^{32}-1$ as the value of the uplink NAS COUNT parameter.

NOTE: The MME and UE only uses the $2^{32}-1$ as the value of the uplink NAS COUNT for the purpose of deriving K_{eNB} and do not actually set the uplink NAS COUNT to $2^{32}-1$. The reason for choosing such a value not in the normal NAS COUNT range, i.e., $[0, 2^{24}-1]$ is to avoid any possibility that the value may be used to derive the same K_{eNB} again.

9.3 Recommendations on AKA at IRAT-mobility to E-UTRAN

After a handover from GERAN or UTRAN into E-UTRAN, it is strongly recommended to run an AKA and perform a key change on-the-fly of the entire key hierarchy as soon as possible after the handover if there is no native security context in E-UTRAN.

When a UE moves in IDLE mode from GERAN or UTRAN into E-UTRAN, it is strongly recommended to run an AKA if there is no native security context in E-UTRAN, either after the TAU procedure that establishes an EPS security context in the MME and UE, or when the UE establishes cryptographically protected radio bearers.

9.4 Attach procedures

9.4.1 Attach in UTRAN

This subclause covers the case that the UE includes a mapped GUTI into the "old P-TMSI" Information Element of the Attach Request.

NOTE 1: TS 23.060 states conditions under which a valid P-TMSI or a P-TMSI that is mapped from a valid GUTI ("mapped GUTI") is inserted in the Information Element "old P-TMSI" in the Attach Request.

If the UE has a current EPS NAS security context, it shall include a truncated NAS-token, as defined in subclause 9.1.1, into the P-TMSI signature IE of the Attach Request. It shall also include the KSI equal to the value of the eKSI associated with the current EPS security context.

If the UE does not have a current EPS NAS security context, the UE shall set the truncated NAS-token to all zero and the KSI to '111' to indicate the UE has no keys available.

The SGSN shall forward the P-TMSI signature including the truncated NAS-token to the old MME. The MME may check a non-zero NAS-token as described in subclause 9.1.1. If successful, the MME responds with an Identification Response to the SGSN. If unsuccessful the MME responds with an appropriate error cause which should initiate the security functions in the SGSN.

If P-TMSI Signature includes an all zero NAS-token or the MME chooses not to check the NAS-token, the MME may respond with an Identification Response that does not include keys.

If needed, the MME and UE shall derive CK' and IK' from the K_{ASME} as in subclause 9.1.1. Keys CK' and IK' and KSI sent from the MME shall replace all the UTRAN PS key parameters CK, IK and KSI in the target SGSN if any. Keys CK' and IK' and the KSI shall replace all the currently stored UTRAN PS key parameters CK, IK, KSI values on both the USIM and ME. The handling of $START_{PS}$ shall comply with the rules in 3GPP TS 25.331 [24]. The UE may set the $START_{PS}$ value to 0 if it is done before establishment of the RRC connection.

The ME shall use CK' and IK' to derive the GPRS Kc using the c3 function specified in 3GPP TS 33.102 [4]. The ME shall assign the eKSI value (associated with CK' and IK') to the GPRS CKSN. The ME shall update the USIM and ME with the GPRS Kc and GPRS CKSN.

NOTE 2: Due to replacing all the UTRAN PS key parameters CK, IK, KSI with CK', IK' and eKSI on USIM and in ME, a new GPRS Kc needs to be derived from the new UTRAN PS key parameters CK and IK (i.e. CK' and IK'), which is part of the new UMTS security context as well, as any old GPRS Kc stored on USIM and in ME belongs to an old UMTS security context and can no longer be taken into use.

10 Security interworking between E-UTRAN and GERAN

10.1 General

An SGSN supporting interworking between E-UTRAN and GERAN is capable of handling UMTS security contexts and supports the key conversion function c3 specified in TS 33.102 [4]. Such a SGSN is, according to TS 33.102, required to ensure that the UE is authenticated using UMTS AKA, if the UE supports UMTS AKA. Furthermore, the UE must have a USIM to be able to access EPS, except for unauthenticated emergency calls if allowed by regulations. Hence, UMTS AKA is used when the UE is authenticated to the SGSN supporting interworking between E-UTRAN and GERAN even when attached to GERAN, and UMTS security contexts are available. The security procedures for interworking between E-UTRAN and GERAN are therefore quite similar to those between E-UTRAN and UTRAN.

10.2 RAU and TAU procedures

10.2.1 RAU procedures in GERAN

This subclause covers both the cases of idle mode mobility from E-UTRAN to GERAN and of Idle Mode Signaling Reduction, as defined in TS 23.401 [2].

As the target SGSN and UE are capable of handling UMTS security contexts clause 9.1.1 applies here with the following changes

- the target SGSN shall derive GPRS cipher key K_c from CK' and IK' with the help of the key conversion function $c3$ defined by TS 33.102 [4], and the target SGSN and UE shall derive GPRS K_{C128} as defined by TS 33.102 [4] from CK' and IK' when the new encryption algorithm selected by the target SGSN requires K_{C128} ; the target SGSN and UE shall assign the eKSI value (associated with the CK' and IK') to the GPRS CKSN associated with the GPRS K_{C128} .
- the target SGSN shall select the encryption algorithm to use in GERAN.

10.2.2 TAU procedures in E-UTRAN

This subclause covers both the cases of idle mode mobility from GERAN to E-UTRAN and of Idle Mode Signaling Reduction, as defined in TS 23.401 [2].

As the SGSN shares a UMTS security context with the UE clause 9.1.2 applies here without changes.

10.3 Handover

10.3.1 From E-UTRAN to GERAN

As the target SGSN and the UE are capable of handling UMTS security contexts clause 9.2.1 applies here with the following changes:

- the target SGSN shall derive GPRS cipher key K_c from CK' and IK' with the help of the key conversion function $c3$ as defined by TS 33.102 [4], and target SGSN and UE shall derive GPRS K_{C128} as defined by TS 33.102 [4] from CK' and IK' when the new encryption algorithm selected by the target SGSN requires K_{C128} . The target SGSN and UE shall assign the eKSI value (associated with the CK' and IK') to the GPRS CKSN associated with the GPRS K_{C128} .
- the target SGSN shall select the encryption algorithm to use in GERAN after handover.
- Whether ciphering is considered active in the target GERAN after handover from E-UTRAN shall be determined according to the principles for handover to GERAN in TS 44.060 [25].

10.3.2 From GERAN to E-UTRAN

10.3.2.1 Procedures

As the SGSN shares a UMTS security context with the UE clause 9.2.2 applies here without changes.

10.4 Recommendations on AKA at IRAT-mobility to E-UTRAN

See recommendation provided by subclause 9.3.

10.5 Attach procedures

10.5.1 Attach in GERAN

As the SGSN is capable of handling UMTS security contexts clause 9.1.1 applies here with the following changes

- the SGSN and UE shall derive GSM cipher key K_c as defined by TS 33.102 [4] from CK' and IK' , and the SGSN and UE shall derive K_{C128} as defined by TS 33.102 [4] from CK' and IK' when the new encryption algorithm selected by the target SGSN requires K_{C128} ;
- SGSN shall select the encryption algorithm to use in GERAN.

11 Network Domain Control Plane protection

The protection of IP based control plane signalling for EPS and E-UTRAN shall be done according to NDS/IP as specified in TS 33.210 [5]. S3, S6a and S10 interfaces carry subscriber specific sensitive data, e.g. cryptographic keys. Thus in addition to the mandatory integrity protection according to NDS/IP, traffic on these interfaces shall be confidentiality-protected according to NDS/IP.

In order to protect the S1 and X2 control plane as required by clause 5.3.4a, it is required to implement IPsec ESP according to RFC 4303 [7] as specified by TS 33.210 [5]. For both S1-MME and X2-C, IKEv2 certificates based authentication according to TS 33.310 [6] shall be implemented. For S1-MME and X2-C, tunnel mode IPsec is mandatory to implement on the eNB. On the core network side a SEG may be used to terminate the IPsec tunnel.

NOTE 1: In case control plane interfaces are trusted (e.g. physically protected), there is no need to use protection according to TS 33.210 [5] and TS 33.310 [6].

Transport mode IPsec is optional for implementation on the X2-C and S1-MME.

NOTE 2: Transport mode can be used for reducing the protocol overhead added by IPsec.

If the sender of IPsec traffic uses DiffServ Code Points (DSCPs) to distinguish different QoS classes, either by copying DSCP from the inner IP header or directly setting the encapsulating IP header's DSCP, the resulting traffic may be reordered to the point where the receiving node's anti-replay check discards the packet. If different DSCPs are used on the encapsulating IP header, then to avoid packet discard under one IKE SA and with the same set of traffic selectors, distinct Child-SAs should be established for each of the traffic classes (using the DSCPs as classifiers) as is specified in RFC 4301 [34].

Other 3GPP specifications may specify other IKEv2 and certificate profiles and IPsec implementation details for specific types of eNBs. The provisions in such other 3GPP specifications shall take precedence over the provisions in the present clause for those specific eNB types only if explicitly listed here. In particular, the provisions for HeNBs specified in TS 33.320 [27] shall take precedence over the provisions in this clause.

12 Backhaul link user plane protection

The protection of user plane data between the eNB and the UE by user specific security associations is covered by clause 5.1.3 and 5.1.4.

In order to protect the S1 and X2 user plane as required by clause 5.3.4, it is required to implement IPsec ESP according to RFC 4303 [7] as profiled by TS 33.210 [5], with confidentiality, integrity and replay protection.

On the X2-U and S1-U, transport mode IPsec is optional for implementation.

NOTE 1: Transport mode can be used for reducing the protocol overhead added by IPsec.

Tunnel mode IPsec is mandatory to implement on the eNB for X2-U and S1-U. On the core network side a SEG may be used to terminate the IPsec tunnel..

If the sender of IPsec traffic uses DiffServ Code Points (DSCPs) to distinguish different QoS classes, either by copying DSCP from the inner IP header or directly setting the encapsulating IP header's DSCP, the resulting traffic may be reordered to the point where the receiving node's anti-replay check discards the packet. If different DSCPs are used on the encapsulating IP header, then to avoid packet discard under one IKE SA and with the same set of traffic selectors, distinct Child-SAs should be established for each of the traffic classes (using the DSCPs as classifiers) as is specified in RFC 4301 [34].

For both S1 and X2 user plane, IKEv2 with certificates based authentication shall be implemented. The certificates shall be implemented according to the profile described by TS 33.310 [6]. IKEv2 shall be implemented conforming to the IKEv2 profile described in TS 33.310 [6]. Other 3GPP specifications may specify other IKEv2 and certificate profiles and IPsec implementation details for specific types of eNBs. The provisions in such other 3GPP specifications shall take precedence over the provisions in the present clause for those specific eNB types only if explicitly listed here. In particular, the provisions for HeNBs specified in TS 33.320 [27] shall take precedence over the provisions in this clause.

NOTE 2: In case S1 and X2 user plane interfaces are trusted (e.g. physically protected), the use of IPsec/IKEv2 based protection is not needed.

13 Management plane protection over the S1 interface

For the management plane protection of relay nodes the provisions in clause D.2.5 apply instead of the provisions given in this clause.

For management plane protection the requirements in clause 5.3.2 apply.

In order to achieve such protection, IPsec ESP according to RFC 4303 [7] as profiled by TS 33.210 [5] shall be implemented for all O&M related traffic, i.e. the management plane, with confidentiality, integrity and replay protection.

Tunnel mode IPsec shall be implemented on the eNB for supporting the management plane. On the core network side a SEG may be used to terminate the IPsec tunnel. If no SEG is used, the IPsec tunnel may be terminated in the element manager.

If the sender of IPsec traffic uses DiffServ Code Points (DSCPs) to distinguish different QoS classes, either by copying DSCP from the inner IP header or directly setting the encapsulating IP header's DSCP, the resulting traffic may be reordered to the point where the receiving node's anti-replay check discards the packet. If different DSCPs are used on the encapsulating header, then to avoid packet discard under one IKE SA and with the same set of traffic selectors, distinct Child-SAs should be established for each of the traffic classes (using the DSCPs as classifiers) as is specified in RFC 4301 [34].

For the management plane, IKEv2 with certificates based authentication shall be implemented on the eNB. The certificates shall be implemented according to the profile described by TS 33.310 [6]. IKEv2 shall be implemented conforming to the IKEv2 profile described in TS 33.310 [6]. Other 3GPP specifications may specify other IKEv2 and certificate profiles and IPsec implementation details for specific types of eNBs.

Other 3GPP specifications may specify other security mechanisms and certificate profiles for specific types of eNBs for the case when the management traffic is not carried over the same backhaul link as S1 traffic. If other security mechanisms are specified, they shall provide mutual authentication based on certificates, as well as confidentiality, integrity and replay protection. These functions shall have at least equal strength as that provided by the use of IKEv2/IPsec.

The provisions in such other 3GPP specifications shall take precedence over the provisions in the present clause for those specific eNB types only if explicitly listed here. In particular, the provisions for HeNBs specified in TS 33.320 [27] shall take precedence over the provisions in this clause.

NOTE 1: X2 does not carry management plane traffic.

NOTE 2: In case the S1 management plane interfaces are trusted (e.g. physically protected), the use of protection based on IPsec/IKEv2 or equivalent mechanisms is not needed

14 SRVCC between E-UTRAN and Circuit Switched UTRAN/GERAN

14.1 From E-UTRAN to Circuit Switched UTRAN/GERAN

Single Radio Voice Call Continuity (SRVCC) is specified in 3GPP TS 23.216 [22].

The MME shall select the current NAS downlink COUNT value to use in the handover and then increase the stored NAS downlink COUNT value by 1.

NOTE 0: Increasing the NAS downlink COUNT by 1 is to ensure that a fresh NAS downlink COUNT is used for any future purposes.

The MME and the UE shall derive a confidentiality key CK_{SRVCC} , and an integrity key IK_{SRVCC} from K_{ASME} of the current EPS security context and the selected NAS downlink COUNT with the help of a one-way key derivation function KDF as specified in clause A.12.

The KDF returns a 256-bit output, where the 128 most significant bits are identified with CK_{SRVCC} and the 128 least significant bits are identified with IK_{SRVCC} .

The MME shall also provide the 4 LSB of the selected NAS downlink COUNT value to the source eNB, which then includes the bits to the HO Command to the UE. The UE shall use the received 4 LSB and its stored NAS downlink COUNT to estimate the NAS downlink COUNT selected by the MME.

NOTE 1: It is left to the implementation how to estimate the NAS downlink COUNT.

The UE shall ensure that the estimated NAS downlink COUNT has not been used to calculate a CK' and IK' in a previous successful or unsuccessful PS or SRVCC handover. If the estimated NAS downlink COUNT is greater than all the estimated NAS downlink COUNTs either used by the UE for key derivation in a handover or received in a NAS message that passed its integrity check, the UE shall update its stored NAS downlink COUNT as though it has successfully integrity checked a NAS message with that estimated NAS downlink COUNT. In particular, the stored NAS downlink COUNT shall never be decreased.

UE and MME shall assign the value of eKSI to KSI. MME shall transfer CK_{SRVCC} , IK_{SRVCC} with KSI and the UE security capability to the MSC server enhanced for SRVCC. The MSC server enhanced for SRVCC shall replace all the stored UTRAN CS key parameters CK, IK, KSI, if any, with CK_{SRVCC} , IK_{SRVCC} , KSI received from the MME when the SRVCC handover is successful. The UE shall replace all the stored UTRAN CS key parameters CK, IK, KSI, if any, with CK_{SRVCC} , IK_{SRVCC} , KSI in both ME and USIM. $START_{CS}$ shall comply with the rules in 3GPP TS 25.331 [24].

The ME shall use CK_{SRVCC} and IK_{SRVCC} to derive the GSM CS Kc using the c3 function specified in 3GPP TS 33.102 [4]. The ME shall assign the eKSI value (associated with CK_{SRVCC} and IK_{SRVCC}) to the GSM CS CKSN (associated with the GSM CS Kc). The ME shall update the USIM and ME with the GSM CS Kc and GSM CS CKSN.

NOTE 2: The new derived security context (including CK_{SRVCC} , IK_{SRVCC} , and KSI) replacing the stored values in the USIM is for allowing to reuse the derived security context without invoking the authentication procedure in subsequent connection set-ups, and also for avoiding that one KSI value indicates to two different key sets and consequently leads to security context desynchronization.

NOTE 3: An operator concerned about the security of keys received from an E-UTRAN of another operator may want to enforce a policy in the MSC server enhanced for SRVCC to run a UMTS AKA as soon as possible after the handover. One example of ensuring this is the deletion of the mapped UMTS security context in the enhanced MSC server after the UE has left active state.

NOTE 4: Due to replacing all the UTRAN CS key parameters CK, IK, KSI with CK_{SRVCC} , IK_{SRVCC} and KSI on USIM and in ME, a new GSM CS Kc needs to be derived from the new UTRAN CS key parameters CK and IK (i.e. CK_{SRVCC} and IK_{SRVCC}), which is part of the new UMTS security context as well, as any old GSM CS Kc stored on USIM and in ME, belongs to an old UMTS security context and can no longer be taken into use.

If the SRVCC is from E-UTRAN to GERAN, the above description in this section applies as well for the MME, the enhanced MSC server and the UE. The enhanced MSC server shall in addition derive GSM CS cipher key Kc from CK_{SRVCC} and IK_{SRVCC} with the help of the key conversion function c3 as specified in TS 33.102 [4], and assign the value

of eKSI to GSM CS CKSN associated with the GSM CS Kc, and the target MSC server and UE shall compute the 128-bit GSM CS cipher key K_{C128} as specified in TS 33.102 [4] when the new encryption algorithm selected by the target BSS requires K_{C128} . The UE and the enhanced MSC Server shall assign the value of eKSI to GSM CS CKSN associated with the GSM CS Kc.

Non-voice bearers may be handed over during the SRVCC handover operation. For this case, key derivation for non-voice bearers is specified in clause 9.2.1 and 10.3.1 of the present specification. If non-voice bearers are not handed over during the SRVCC handover operation and if the UE subsequently resumes PS services in UTRAN/GERAN, key derivation for the PS domain is specified in clause 9.1.1 and 10.2.1 of the present specification.

If the SRVCC handover is not completed successfully, the new mapped CK_{SRVCC} , IK_{SRVCC} and KSI_{SRVCC} can not be used in the future. The MSC server enhanced for SRVCC shall delete the new mapped CK_{SRVCC} , IK_{SRVCC} and KSI_{SRVCC} and the stored parameters CK_{CS} and IK_{CS} which has the same KSI as the new mapped CK_{SRVCC} , IK_{SRVCC} (if such exist).

14.2 Emergency call in SRVCC from E-UTRAN to circuit switched UTRAN/GERAN

If the SRVCC is for an emergency call and the session in EUTRAN complies with clause 15.2.1, the security procedure in clause 14.1 shall be applied.

If the SRVCC is for an emergency call and the session in EUTRAN complies with clause 15.2.2, the security procedure in clause 14.1 shall not be applied, i.e., no key derivation is needed.

14.3 SRVCC from circuit switched UTRAN/GERAN to E-UTRAN

14.3.1 Procedure

The procedure for SRVCC handover from UTRAN/GERAN CS to E-UTRAN, as far as relevant for security, proceeds as described below.

The activation of NAS and AS security in E-UTRAN, and selection of the key set from the source system for the handover shall be according to following principles:

- i) The source MSC server enhanced for SRVCC shall select the key set most recently generated. This key set may have been generated by either a successful UMTS AKA run in UTRAN or from a UMTS security context mapped from an EPS security context during a previous visit to UTRAN. The UE and source MSC server enhanced for SRVCC may or may not have taken the key set into use. The MSC server enhanced for SRVCC shall transfer this key set to the MME in the CS to PS HO request.

- ii) Activation of AS security in the UE (for details cf. TS 36.331 [21]):

The CS to PS HO command received at the UE shall activate AS security in the UE.

The CS to PS HO Confirmation received at the eNB shall activate AS security in the eNB.

- iii) Activation of NAS security (for details cf. TS 24.301 [9]):

The CS to PS HO request received at the UE shall activate NAS security in the UE.

The Handover Notify received at the MME shall activate NAS security in the MME. In case the MME does not have the UE security capabilities stored from a previous visit, then the MME shall only accept TAU requests from this UE, and shall not send any messages to this UE, until the MME has successfully checked the UE security capabilities received in a TAU request from this UE.

- iv) Both AS and NAS ciphering and integrity protection algorithms shall be selected according to the policy of the target PLMN.

The above four principles consequentially always activate ciphering (potentially NULL ciphering) in E-UTRAN even if it was not active in the source system.

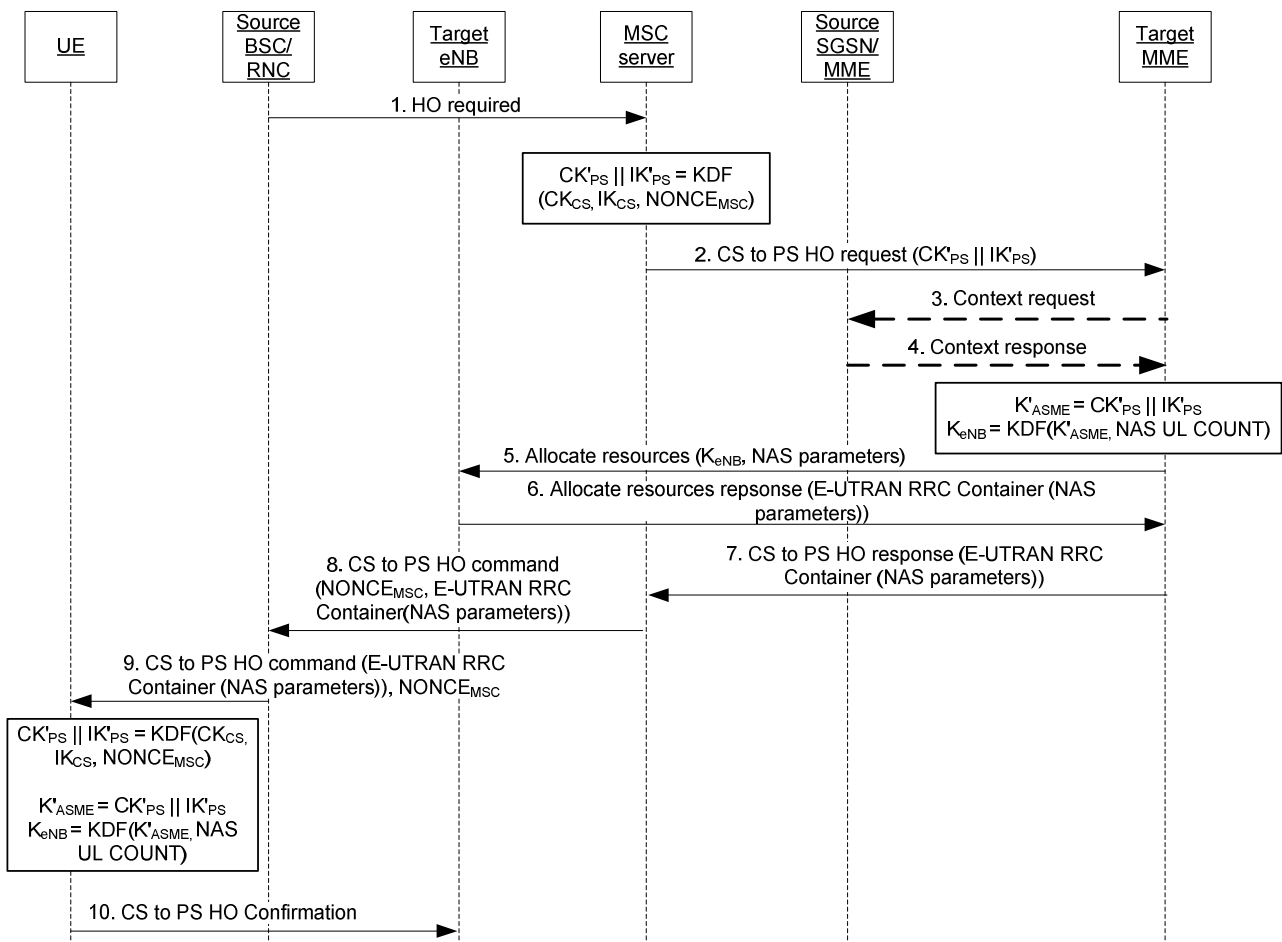

Figure 14.3.1-1: SRVCC handover from UTRAN/GERAN to E-UTRAN. Key derivations in the figure are only shown for UMTS subscribers.

Handover signalling in case of successful handover

Before attempting a handover for a UE, the source RNC/BSC may check if the UE is authenticated using UMTS AKA as described in clause 9.2.2.1 of the present document, and may avoid doing a SRVCC handover to E-UTRAN in case the UE is not authenticated using UMTS AKA and does not have an ongoing emergency call.

NOTE 1: The numbering in the following refers to the signalling numbering in Figure 14.3.1-1.

1. The source BSC/RNC sends HO required to the source MSC server enhanced for SRVCC.
2. For UMTS and GSM subscribers, the source MSC server enhanced for SRVCC shall generate a NONCE_{MSC}.

For UMTS subscribers, the source MSC server enhanced for SRVCC shall derive CK'_{PS} and IK'_{PS} from the NONCE_{MSC} and the latest CK_{CS} and IK_{CS} using the key derivation function as specified in annex B.6 of TS 33.102 [2]. The source MSC server enhanced for SRVCC shall further set the KSI'_{PS} equal to the KSI_{CS} associated with the latest key set as specified for SRVCC from UTRAN/GERAN to HSPA in TS 33.102 [2].

For GSM subscribers, the source MSC server enhanced for SRVCC shall derive GPRS Kc' from the NONCE_{MSC} and the latest GSM Kc using the key derivation function as specified in annex B.7 of TS 33.102 [2]. The source MSC server enhanced for SRVCC shall further set the CKSN'_{PS} equal to the CKSN_{CS} associated with the latest key set as specified for SRVCC from UTRAN/GERAN to HSPA in TS 33.102 [2].

For UMTS subscribers, the MSC server enhanced for SRVCC shall transfer the CK'_{PS}/IK'_{PS} and the KSI'_{PS}, to the target MME in the CS to PS handover request.

For GSM subscribers, the MSC server enhanced for SRVCC shall transfer the GPRS Kc' and the CKSN'_{PS}, to the target MME in the CS to PS handover request.

NOTE 2: The MSC server enhanced for SRVCC does not include any authentication vectors in the CS to PS HO request, since this could result in that authentication vectors intended for use only in the CS domain would end up being used in a PS domain by accident.

NOTE 3: The MSC server enhanced for SRVCC does not include any UE security capability information in the CS to PS HO request, since the target MME either has this information available, or will retrieve the information from the old SGSN. Further, the MSC may not have access to the complete UE security capabilities.

If the MME receives a GPRS Kc' from the source MSC server enhanced for SRVCC in the CS to PS HO request, the MME shall reject the request.

3 and 4. The MME shall discard any CK, IK, Kc, CKSN and KSI retrieved from the old SGSN in a context request procedure

The MME shall create a mapped EPS security context by setting the K'_{ASME} of the mapped EPS security context equal to the concatenation $CK'_{PS} || IK'_{PS}$, where the CK'_{PS} and IK'_{PS} were received in the CS to PS handover request. The MME shall further associate the K'_{ASME} with a KSI_{SGSN} . The value of the KSI_{SGSN} shall be the same as the value of the KSI'_{PS} received in the CS to PS handover request.

NOTE 4: The naming of the KSI_{SGSN} hints at that this identifier is somehow related to an SGSN. However, in this case it is related to the MSC server enhanced for SRVCC. Even though KSI_{MSC} could have been a more appropriate name here, the name KSI_{SGSN} is kept to avoid introducing a new name for the same entity.

The MME shall derive K_{eNB} by applying the KDF as defined in Annex A. 3 using the mapped key K'_{ASME} and $2^{32}-1$ as the value of the uplink NAS COUNT parameter. The uplink and downlink NAS COUNT values for the mapped EPS security context shall be set to start value (i.e. 0) in the MME.

If the MME does not have access to the UE EPS security capabilities the MME shall assume that the default set of EPS security algorithms defined in clause 9.2.2.1 of the present document is supported by the UE (and the MME shall set the UE EPS security capabilities in the mapped EPS security context according to this default set). The same considerations regarding security algorithm selection using the default set as noted in clause 9.2.2.1 of the present document applies here. If the security context information received from the old SGSN contains EPS security capabilities or the MME already have access to EPS security capabilities for the UE, the MME shall populate the mapped EPS security context with these EPS security capabilities instead of falling back to the default set of security algorithms.

If the MME received any authentication vectors from the old SGSN, the MME shall process these authentication vectors according to clause 6.1.6 of the present document.

5. MME shall select the NAS security algorithms (including ciphering and integrity protection) which have the highest priority from its configured list and are also present in the UE EPS security capabilities. MME shall derive the NAS keys from K'_{ASME} using the algorithm types and algorithm IDs as input to the NAS key derivation functions (see Annex A.7). MME generates $NONCE_{MME}$. MME shall include KSI_{SGSN} , $NONCE_{MME}$ and the selected NAS security algorithms in the NAS Security Transparent Container IE of Allocate resources message to the target eNB. MME shall further include K_{eNB} and the UE EPS security capabilities from the mapped EPS security context in the Allocate resources message to the target eNB.
6. The target eNB shall select the AS algorithms (including ciphering for both RRC and UP, and integrity protection for RRC) which have the highest priority from its configured list and is also present in the UE EPS security capabilities. The target eNB creates a target to source transparent container that contains a handover command (the target to source transparent container is denoted "E-UTRAN RRC container" in Figure 14.3.1-1). The handover command includes the selected RRC, UP algorithms and the NAS Security Transparent Container IE, and the eNB sends the target to source transparent container in the Allocate resources Ack message towards the MME. The eNB shall derive the keys for RRC and UP protection from the received K_{eNB} using the key derivation function defined in clause A.7.

NOTE 5: The handover command in the target to source transparent container is not security protected by the target eNB.

7. MME shall include the target to source transparent container received from the target eNB in the CS to PS HO Response message sent to source MSC server enhanced for SRVCC.
8. Source MSC server enhanced for SRVCC shall include the $NONCE_{MSC}$ and the target to source transparent container in the relocation command sent to the BSC/RNC in the CS to PS HO command.

9. The RNC/BSC shall include the $NONCE_{MSC}$ and the transparent container in the CS to PS HO command sent to the UE.

NOTE 6: The CS to PS HO command is integrity protected and optionally ciphered in UTRAN. It is optionally ciphered in GERAN as specified by TS 33.102 [4].

10. For UMTS subscribers the ME shall silently discard the $NONCE_{MME}$ received in received in the NAS Security Transparent Container. The ME shall further derive K'_{ASME} , associate it with KSI_{SGSN} received in the NAS Security Transparent Container IE and derive NAS keys and K_{eNB} following the same key derivations as the MSC and MME performed in steps 2, 3 and 4. The ME shall also derive the RRC and UP keys as the eNB did in (see description for message 6 above). The UE sends a CS to PS HO Confirmation message to the target eNB. The ME shall set the uplink and downlink NAS COUNT values for the mapped EPS security context to start value (i.e. 0)

NOTE 7: Since the MME denies access to E-UTRAN for GSM subscribers, the UE never has to perform any key derivations for GSM subscribers..

The mapped EPS security context established as above shall become the current (cf. subclause 3.1) EPS security context at AS and NAS level. The MME and ME shall overwrite any existing current mapped EPS security context with the newly created one. If the current EPS security context is of type native, then it shall become the non-current native EPS security context. The MME and ME shall in this case also overwrite any existing non-current EPS security context with this current native EPS security context. The CS to PS HO Confirmation messages and all following AS messages in E-UTRAN shall be ciphered and integrity protected according to the policy of the target PLMN.

If the SRVCC handover is not completed successfully, the new mapped EPS security context cannot be used in the future. The MME and the ME shall in this case delete the new mapped EPS security context.

The text regarding subsequent NAS signalling in bullet B) in clause 9.2.2.1 of the present specification applies also after an SRVCC handover from GERAN/UTRAN to E-UTRAN.

In SRVCC handover from GERAN/UTRAN to E-UTRAN, the $START_{PS}$ and $START_{CS}$ values used in UTRAN shall be kept in the volatile memory of the ME, cf. also clause 6.8.11 of TS 33.102 [4].

15 Security Aspects of IMS Emergency Session Handling

15.1 General

Support for IMS Emergency Sessions is defined in the TS 23.401 [2]. Limited service state of a UE is defined in TS 23.122 [26]. IMS Emergency Sessions can be made by normally attached UEs or UEs attached for EPS emergency bearer services. IMS Emergency Services can be authenticated or unauthenticated as defined in clauses below. It depends on the serving network policy if unauthenticated IMS Emergency Sessions are allowed. Any behaviour not explicitly specified as being special to IMS Emergency Sessions is handled in accordance to normal procedures.

The E-UTRAN Initial Attach procedure, with Attach Type "Emergency", is used by UEs that need to receive EPS emergency bearer services but cannot receive normal services from the network.

For an Initial Attach with Attach Type "Emergency" the UE includes the IMSI in the Attach request if the UE does not have a valid GUTI. The UE shall include the IMEI when the UE has no IMSI, no valid GUTI according to [2].

When involved in an Attach for EPS emergency bearer services the MME applies the parameters from MME Emergency Configuration Data for the EPS emergency bearer establishment. Any potentially stored IMSI related subscription data is ignored by the MME according to [2].

When involved in an Attach for EPS emergency bearer services the MME does not send any Notify Request to an HSS.

A UE attached for EPS emergency bearer services using NULL algorithms shall keep the NULL algorithms and corresponding NAS COUNTs when in EMM-IDLE mode so that it is reachable for subsequent IMS Emergency Sessions without the need to attach for EPS emergency bearer services again. The NULL algorithms shall be de-

selected and corresponding NAS COUNTs shall be removed when the UE goes to EMM-DEREGISTERED state or when another EPS NAS security context is activated.

The MME or UE shall always release any established non-emergency bearers, when the authentication fails in the UE or in the MME.

15.2 Security procedures and their applicability

15.2.1 Authenticated IMS Emergency Sessions

15.2.1.1 General

UEs that are not in limited service state, shall initiate normal initial attach when not already attached to receive EPS emergency bearer services.

The security mode control procedure shall be applied as part of EPS emergency bearer establishment as defined in TS 23.401 [2]. Thus, integrity protection (and optionally ciphering) shall be applied as for normal EPS bearers. If authentication fails for any reason, the handling of the EPS emergency bearer services shall be handled as specified in clauses 15.2.1 and 15.2.2 below. Once the IMS Emergency Session is in progress with NAS and AS integrity protection (and optionally ciphering) applied, failure of integrity checking or ciphering (for both NAS and AS) is an unusual circumstance and shall be treated as in the case of a normal EPS bearer.

15.2.1.2 UE and MME share a current security context

If the UE already has a current EPS security context and attempts to set up an IMS Emergency Session, the UE shall use this EPS security context to protect NAS, RRC and UP traffic. If the MME successfully validates a request for EPS emergency bearer services using the current EPS security context, the MME should accept this request. A request for EPS emergency bearer services is defined to be, for the purposes of this document, an Attach request message for EPS emergency bearer services or a PDN Connectivity request message for EPS emergency bearer services.

NOTE 1: It is defined in TS 23.401 [2] and TS 24.301 [9] how Attach requests and/or PDN Connectivity requests are used to set up EPS emergency bearer services.

If the authentication fails during a normal Attach procedure, or a Service request procedure, while the UE is in normal service mode, and the UE intends to set up an IMS Emergency Session, the UE shall retry by sending an Attach request for EPS emergency bearer services.

If the MME attempts to authenticate the UE after receiving a request for EPS emergency bearer services which was integrity protected by the current EPS NAS security context and the authentication failed and if the serving network policy does not allow unauthenticated IMS Emergency Sessions, the UE and MME shall proceed as for set up of normal EPS bearers as described in clause 6.1.1.

If the MME attempts to authenticate the UE after receiving a request for EPS emergency bearer services which was integrity protected by the current EPS NAS security context and the authentication failed and the serving network policy allows unauthenticated IMS Emergency Sessions, then the UE and the MME behaviours are described in the paragraph below.

If the authentication failure is detected in the UE or in the MME during an attach procedure for EPS emergency bearer services or a PDN connectivity request procedure for EPS emergency bearer services, and the related signalling messages were correctly integrity-protected by the current EPS security context, the set up of the EPS emergency bearers shall then proceed in one of two ways:

- a) The set-up proceeds according to clause 15.2.2. In this case, there is no need for the UE to re-attach, and the MME requests the use of the NULL ciphering and integrity algorithms in the same way as described in clause 15.2.2.2 for the case that UE and MME share no EPS security context.

NOTE 2: If the authentication failure is detected in the MME then the UE is not aware of the failure in the MME, but still needs to be prepared, according to the conditions specified in TS 24.301, to accept a NAS SMC from the MME requesting the use of the NULL ciphering and integrity algorithms.

- b) Or else, if the serving network policy allows unauthenticated IMS Emergency Sessions and MME continues using the current security context, the use of the EPS emergency bearers may proceed as described below for the case of an AKA run while a PDN connection for emergency bearer services exists.

NOTE 3: Regardless of if the authentication failed in the UE or in the MME, the MME can assume that the UE will accept that NULL integrity and ciphering algorithms are selected in the security mode control procedure.

If AKA is run while a PDN connection for emergency bearer services exists, the MME and UE shall behave as follows:

UE behavior:

- Upon successful authentication verification in the UE, the UE shall send RES to the MME.

NOTE 4: If the authentication failure is detected in the MME, the UE is not aware of the failure in the MME if the MME continues to use the current security context with the UE. The UE consider itself to be in normal service, if it was normal attached before the PDN connectivity request procedure for EPS emergency bearer services was initiated, until the MME releases the non-emergency bearers established with the UE.

- Alternatively, upon authentication verification failure in the UE, the UE shall send an Authentication Failure message to the MME. The UE shall continue using the current EPS security context. If the UE receives a NAS security mode command selecting NULL integrity and ciphering algorithms, the UE shall accept this as long as the IMS Emergency session progresses.

MME behavior:

- If the serving network policy requires IMS Emergency Sessions to be authenticated, the MME shall, after the unsuccessful comparison of RES to XRES, i.e. AKA failure, proceed as if the request for EPS emergency bearers was a request for normal EPS bearer services. The MME should not send an Authentication Reject message if authentication failed in the MME and the serving network policy allows unauthenticated IMS Emergency Sessions. If the MME does not send an Authentication Reject message it shall continue using the current security context with the UE.
- After receiving both, the EC Indication and the Authentication Failure message, the MME shall continue using the current security context with the UE for establishing an EPS emergency bearer.

NOTE : In the case that NAS COUNT values are about to wrap around, and AKA fails, or if the MME is unable to fetch new authentication vectors, the handling of the EPS emergency bears are as described by TS 24.301 [9].

15.2.2 Unauthenticated IMS Emergency Sessions

15.2.2.1 General

Authentication may fail for a UE attached for EPS emergency bearer services just as for a UE attached for normal EPS bearer services when the UE tries to establish an IMS Emergency Session.

As defined in TS 23.401 [2] and as a serving network option, IMS Emergency Sessions may be established in limited service state without the network having to authenticate the UE or apply ciphering or integrity protection for either AS or NAS.

The following are the only identified cases where the "security procedure not applied" option may be used:

- a) Authentication is impossible because the USIM is absent;
- b) Authentication is impossible because the serving network cannot obtain authentication vectors due to a network failure;
- c) Authentication is impossible because the USIM is in limited service mode in the serving network (e.g. there is no roaming agreement or the IMSI is barred, etc.);
- d) Authentication is possible but the serving network cannot successfully authenticate the USIM.

If the ME receives a NAS SMC selecting EIA0 (NULL integrity) for integrity protection, and EEA0 (NULL ciphering) for encryption protection, then:

- the ME shall mark any stored native EPS NAS security context on the USIM /non-volatile ME memory as invalid; and
- the ME shall not update the USIM/non-volatile ME memory with the current EPS NAS security context.

These two rules override all other rules regarding updating the EPS NAS security context on the USIM/non-volatile ME memory, in this specification.

If EIA0 is used, and the NAS COUNT values wrap around, and a new K_{ASME} has not been established before the NAS COUNT wrap around, the NAS connection shall be kept.

NOTE: For unauthenticated emergency calls, EIA0, i.e., null integrity algorithm, is used for integrity protection. Additionally, as the NAS COUNT values are allowed to wrap around, the initialization of the NAS COUNT values are not crucial. Uplink and downlink NAS COUNT are incremented for NAS message that use EIA0, as for any other NAS messages.

Since a UE with a 2G SIM cannot be authenticated via EPS AKA, it shall be considered by the MME to be unauthenticated in E-UTRAN. A UE with a 2G SIM shall at an IRAT handover to E-UTRAN when an IMS Emergency Service is active, be considered by the MME to be unauthenticated. In such a scenario, EIA0 shall be used in E-UTRAN after handover if the target network policy allows unauthenticated IMS Emergency Sessions.

A handover from E-UTRAN to another RAT, of an unauthenticated IMS Emergency Session, shall result in an unauthenticated IMS Emergency Session or a circuit switched emergency call (depending on if it is a PS handover or SRVCC) in the other RAT.

15.2.2.2 UE and MME share no security context

If the MME attempts to authenticate the UE after receiving the EPS emergency bearer setup request and the authentication failed and if the serving network policy does not allow unauthenticated IMS Emergency Sessions, the UE and MME shall proceed as for normal EPS bearer setup requests as described in clause 6.1.1.

If the UE is not yet authenticated and while the UE is trying to setup an IMS Emergency Session, the authentication failed in the UE, the UE shall wait for a NAS SMC command to set up an unauthenticated emergency bearer. If the serving network policy supports unauthenticated IMS Emergency Sessions, only then the MME shall support unauthenticated EPS emergency bearer setup. In this case, the behaviours of the UE and the MME are as described below.

The confluence of EPS emergency bearer setup and authentication failure means that the UE is considered by the MME and UE itself to be in LSM even though the UE could have been in normal service mode before the EPS emergency bearer setup.

UE behavior:

After sending EC Indication to the serving network the UE shall know of its own intent to establish an IMS Emergency Session.

- The UE will proceed as specified for the non-emergency case in clauses 6 and 7 of this specification except that the UE shall accept a NAS SMC selecting EEA0 and EIA0 algorithms from the MME.

NOTE: In case of authentication success the MME will send a NAS SMC selecting algorithms as defined in clause 7 of this specification, i.e. with a non-NULL integrity algorithm, and the UE will accept it.

MME behavior:

After receiving EC Indication from the UE, the MME knows of that UE's intent to establish an IMS Emergency Session.

- If the MME cannot identify the subscriber, or cannot obtain authentication vectors, the MME shall send NAS SMC with NULL algorithms to the UE regardless of the supported algorithms announced previously by the UE.

NOTE: The case where the MME cannot obtain authentication vectors includes also all the cases where IMSI is required by the MME (see TS 23.401[2], clause 4.3.12.1).

- After the unsuccessful comparison of RES to XRES, i.e. AKA failure, the MME shall send NAS SMC with NULL algorithms to the UE regardless of the supported algorithms announced previously by the UE.

- After the receiving of both, the EC Indication and the Authentication Failure messages, the MME shall send NAS SMC with NULL algorithms to the UE regardless of the supported algorithms announced previously by the UE.

If the serving network policy does not allow unauthenticated IMS Emergency Sessions, the MME shall reject the unauthenticated EPS emergency bearer setup request from the UE.

15.2.3 Void

15.2.4 Key generation procedures for unauthenticated IMS Emergency Sessions

15.2.4.1 General

An unauthenticated UE does not share a complete EPS NAS security context with the network. Since there has been no successful EPS AKA run, the UE and the MME does not share a K_{ASME} . When the UE and the MME does not share a K_{ASME} the only possibility for an MME that allows unauthenticated IMS Emergency Sessions is to run with the NULL integrity algorithm EIA0 and the NULL ciphering algorithm EEA0. These algorithms are not affected by the choice of key. Therefore the UE and the MME independently generate a K_{ASME} in an implementation defined way and populate the EPS NAS security context with this K_{ASME} to be used when activating an EPS NAS security context for which no successful EPS AKA run has been made. After this EPS NAS security context is activated all key derivations proceed as if they were based on a K_{ASME} generated from an EPS AKA run.

Even if no confidentiality or integrity protection is provided by EIA0 and EEA0, the UE and network treat the EPS security context with the independently generated K_{ASME} as if it contained a normally generated K_{ASME} and hence share an EPS security context (see TS 24.301[9]).

15.2.4.2 Handover

When UE attempts to make X2/S1 handover, UE and eNB derive and transfer the keys as normal to re-use the normal handover mechanism. Since the derived keys have no ability to affect the output of the NULL algorithms it is irrelevant that the network and the UE derive different keys. Furthermore, section 7.2.4a describes how the algorithm selection is handled for unauthenticated emergency call. This implies that source eNB will forward UE EPS security capability which contains EIA0 and EEA0 only to target eNB. So the target eNB can only select EIA0 for integrity protection and EEA0 for confidential protection. If the UE does not receive any selection of new AS security algorithms during an intra-eNB handover, the UE continues to use the same algorithms as before the handover (see TS 36.331 [21]).

NOTE: If the target eNB is a Rel-8 eNB, it can't support EIA0 and EEA0. The handover will be rejected because of the failure of algorithm negotiation.

16 Void

Annex A (normative): Key derivation functions

A.1 KDF interface and input parameter construction

A.1.1 General

All key derivations (including input parameter encoding) for EPS shall be performed using the key derivation function (KDF) specified in TS 33.220 [8]. This clause specifies how to construct the input string, *S*, to the KDF (which is input together with the relevant key). For each of the distinct usages of the KDF, the input parameters *S* are specified below.

A.1.2 FC value allocations

The FC number space used is controlled by TS 33.220 [8], FC values allocated for this specification are in range of 0x10 – 0x1F.

A.2 K_{ASME} derivation function

When deriving a K_{ASME} from CK, IK and SN id when producing authentication vectors, and when the UE computes K_{ASME} during AKA, the following parameters shall be used to form the input *S* to the KDF.

- FC = 0x10,
- P0 = SN id,
- L0 = length of SN id (i.e. 0x00 0x03),
- P1 = SQN \oplus AK
- L1 = length of SQN \oplus AK (i.e. 0x00 0x06)

The exclusive or of the Sequence Number (SQN) and the Anonymity Key (AK) is sent to the UE as a part of the Authentication Token (AUTN), see TS 33.102. If AK is not used, AK shall be treated in accordance with TS 33.102, i.e. as 000...0.

The SN id consists of MCC and MNC, and shall be encoded as an octet string according to Figure A.2-1.

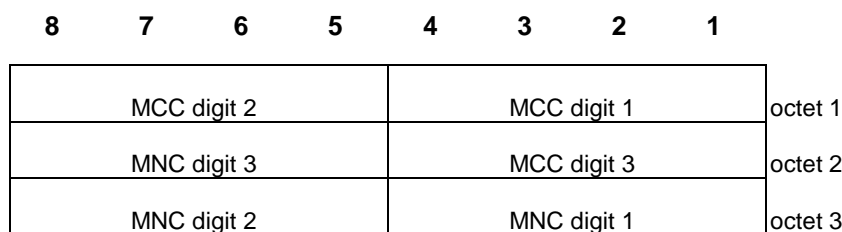

Figure A.2-1 Encoding of SN id as an octet string

The coding of the digits of MCC and MNC shall be done according to TS 24.301 [9].

The input key *Key* shall be equal to the concatenation CK || IK of CK and IK.

A.3 K_{eNB} derivation function

When deriving a K_{eNB} from K_{ASME} and the uplink NAS COUNT in the UE and the MME the following parameters shall be used to form the input S to the KDF.

- FC = 0x11,
- P0 = Uplink NAS COUNT,
- L0 = length of uplink NAS COUNT (i.e. 0x00 0x04)

The input key shall be the 256-bit K_{ASME} .

This function is applied when cryptographically protected E-UTRAN radio bearers are established and when a key change on-the-fly is performed.

A.4 NH derivation function

When deriving a NH from K_{ASME} the following parameters shall be used to form the input S to the KDF.

- FC = 0x12
- P0 = SYNC-input
- L0 = length of SYNC-input (i.e. 0x00 0x20)

The SYNC-input parameter shall be the newly derived K_{eNB} for the initial NH derivation, and the previous NH for all subsequent derivations. This results in a NH chain, where the next NH is always fresh and derived from the previous NH.

The input key shall be the 256-bit K_{ASME} .

A.5 K_{eNB}^* derivation function

When deriving a K_{eNB}^* from current K_{eNB} or from fresh NH and the target physical cell ID in the UE and eNB as specified in clause 7.2.8 for handover purposes the following parameters shall be used to form the input S to the KDF.

- FC = 0x13
- P0 = PCI (target physical cell id)
- L0 = length of PCI (i.e. 0x00 0x02)
- P1 = EARFCN-DL (target physical cell downlink frequency)
- L1 length of EARFCN-DL (i.e. L1 = 0x00 0x02 if EARFCN-DL is between 0 and 65535, and L1 = 0x00 0x03 if EARFCN-DL is between 65536 and 262143)

NOTE: The length of EARFCN-DL cannot be generally set to 3 bytes for backward compatibility reasons: A Rel-8 entity (UE or eNB) would always assume an input parameter length of 2 bytes for the EARFCN-DL. This would lead to different derived keys if another entity assumed an input parameter length of 3 bytes for the EARFCN-DL.

The input key shall be the 256-bit NH when the index in the handover increases, otherwise the current 256-bit K_{eNB} .

A.6 Void

A.7 Algorithm key derivation functions

When deriving keys for NAS integrity and NAS encryption algorithms from K_{ASME} and algorithm types and algorithm IDs, and keys for RRC integrity, UP integrity in the case of relay nodes, and RRC/UP encryption algorithms from K_{eNB} , in the UE, MME and eNB the following parameters shall be used to form the string S.

- FC = 0x15
- P0 = algorithm type distinguisher
- L0 = length of algorithm type distinguisher (i.e. 0x00 0x01)
- P1 = algorithm identity
- L1 = length of algorithm identity (i.e. 0x00 0x01)

The algorithm type distinguisher shall be NAS-enc-alg for NAS encryption algorithms and NAS-int-alg for NAS integrity protection algorithms. The algorithm type distinguisher shall be RRC-enc-alg for RRC encryption algorithms, RRC-int-alg for RRC integrity protection algorithms, UP-enc-alg for UP encryption algorithms and, in the case of relay nodes, UP-int-alg for UP integrity protection algorithms (see table A.7-1). The values 0x07 to 0xf0 are reserved for future use, and the values 0xf1 to 0xff are reserved for private use.

Table A.7-1: Algorithm type distinguishers

Algorithm distinguisher	Value
NAS-enc-alg	0x01
NAS-int-alg	0x02
RRC-enc-alg	0x03
RRC-int-alg	0x04
UP-enc-alg	0x05
UP-int-alg	0x06

The algorithm identity (as specified in clause 5) shall be put in the four least significant bits of the octet. The two least significant bits of the four most significant bits are reserved for future use, and the two most significant bits of the most significant nibble are reserved for private use. The entire four most significant bits shall be set to all zeros.

For NAS algorithm key derivations, the input key shall be the 256-bit K_{ASME} , and for UP and RRC algorithm key derivations, the input key shall be the 256-bit K_{eNB} .

For an algorithm key of length n bits, where n is less or equal to 256, the n least significant bits of the 256 bits of the KDF output shall be used as the algorithm key.

A.8 K_{ASME} to CK', IK' derivation at handover

This input string is used when there is a need to derive CK' || IK' from K_{ASME} during mapping of security contexts from E-UTRAN to GERAN/UTRAN at handover. K_{ASME} is a 256-bit entity, and so is the concatenation of CK and IK (which are 128 bits each). The following input parameters shall be used.

- FC = 0x16
- P0 = NAS downlink COUNT value
- L0 = length of NAS downlink COUNT value (i.e. 0x00 0x04)

The input key shall be K_{ASME} .

A.9 NAS token derivation for inter-RAT mobility

The NAS-token used to ensure that a RAU is originating from the correct UE during IDLE mode mobility from E-UTRAN to UTRAN and GERAN, shall use the following input parameters.

- FC = 0x17
- P0 = Uplink NAS COUNT
- L0 = length of uplink NAS COUNT (i.e. 0x00 0x04)

The input key shall be the 256-bit K_{ASME} .

A.10 K'_{ASME} from CK, IK derivation during handover

This input string is used when there is a need to derive a K'_{ASME} from concatenation of CK and IK and a $NONCE_{MME}$ during mapping of security contexts between GERAN/UTRAN and E-UTRAN during handover to E-UTRAN.

K'_{ASME} is a 256-bit value. The $NONCE_{MME}$ is a 32-bit value. The following input parameters shall be used.

- FC = 0x18
- P0 = $NONCE_{MME}$
- L0 = length of $NONCE_{MME}$ (i.e. 0x00 0x04)

The input key shall be the concatenation of CK || IK.

The generation of $NONCE_{MME}$ shall be sufficiently random such that both the probability of the MME generating equal values of $NONCE_{MME}$ and the probability of an attacker being able to predict future values of $NONCE_{MME}$ over the duration of practical eavesdropping attacks on a particular user are extremely low.

NOTE: A well-seeded strong PRNG would meet this requirement. A true RNG is not required.

A.11 K'_{ASME} from CK, IK derivation during idle mode mobility

This input string is used when there is a need to derive a K'_{ASME} from CK || IK, $NONCE_{UE}$, and $NONCE_{MME}$ during mapping of security contexts from GERAN/UTRAN to E-UTRAN. K'_{ASME} is a 256-bit entity, and so is the concatenation of CK and IK (which are 128 bits each). The following input parameters shall be used, where $NONCE_{UE}$ are 32 bits long.

- FC = 0x19,
- P0 = $NONCE_{UE}$
- L0 = length of the $NONCE_{UE}$ (i.e. 0x00 0x04)
- P1 = $NONCE_{MME}$
- L1 = length of the $NONCE_{MME}$ (i.e. 0x00 0x04)

The input key shall be the concatenation of CK || IK.

The generation of $NONCE_{UE}$ shall be sufficiently random such that both the probability of the UE generating equal values of $NONCE_{UE}$ and the probability of an attacker being able to predict future values of $NONCE_{UE}$ over the duration of practical eavesdropping attacks on a particular user are extremely low.

NOTE: A well-seeded strong PRNG would meet this requirement. A true RNG is not required.

The generation of $NONCE_{MME}$ shall be as defined in clause A.10.

A.12 $K_{ASME}(\text{_SRVCC})$ to CK_{SRVCC} , IK_{SRVCC} derivation

This input string is used when there is a need to derive $CK_{SRVCC} || IK_{SRVCC}$ used in CS domain either from K_{ASME} during mapping of security contexts between E-UTRAN and GERAN/UTRAN or from K_{ASME_SRVCC} at SRVCC from 5G to UTRAN CS (see Annex J of TS 33.501[43]). K_{ASME} and K_{ASME_SRVCC} are 256-bit elements, and so is the concatenation of CK_{SRVCC} and IK_{SRVCC} (which are 128 bits each).

- FC = 0x1A
- P0 = NAS downlink COUNT value
- L0 = length of NAS downlink COUNT value (i.e. 0x00 0x04)

The input key shall be K_{ASME} or K_{ASME_SRVCC} .

A.13 K_{ASME} to CK' , IK' derivation at idle mobility

This input string is used when there is a need to derive $CK' || IK'$ from K_{ASME} during mapping of security contexts from E-UTRAN to GERAN/UTRAN at idle mobility. K_{ASME} is a 256-bit entity, and so is the concatenation of CK and IK (which are 128 bits each). The following input parameters shall be used.

- FC = 0x1B
- P0 = NAS uplink COUNT value
- L0 = length of NAS uplink COUNT value (i.e. 0x00 0x04)

The input key shall be K_{ASME} .

A.14 (Void)

A.15 Derivation of $S\text{-}K_{eNB}$ or $S\text{-}K_{gNB}$ for dual connectivity

This input string is used when the MeNB and UE derive $S\text{-}K_{eNB}$ or $S\text{-}K_{gNB}$ from K_{eNB} during dual connectivity. The following input parameters shall be used:

- FC = 0x1C
- P0 = Value of the SCG Counter as a non-negative integer
- L0 = length of the SCG Counter value (i.e. 0x00 0x02)

The input key shall be K_{eNB} of the MeNB.

A.16 Derivation of LWIP-PSK

This input string is used when the eNB and UE derive LWIP-PSK from K_{eNB} during LTE WLAN integration using IPsec. The following input parameters shall be used:

- FC = 0x1E
- P0 = Value of the LWIP Counter as a non-negative integer
- L0 = length of the LWIP Counter value (i.e. 0x00 0x02)

The input key shall be K_{eNB} of the eNB.

A.17 Derivation of K_n for IOPS subscriber key separation

This key derivation is for use with the IOPS subscriber key separation mechanism described in Annex F of the present specification.

The input key 'Key' is equal to MK. The following parameters are used to form the input S to the KDF:

- FC = 0x1D
- P0 = $f(n)$
- L0 = length of $f(n)$
- P1 = IMSI
- L1 = length of IMSI

Here $f(n)$ is proprietary, cf. Annex F of the present specification.

A.18 Derivation of $S-K_{WT}$ for LWA

This input string is used when the eNB and UE derive $S-K_{WT}$ from K_{eNB} during LTE WLAN Aggregation. The following input parameters shall be used:

- FC = 0x1F
- P0 = Value of the WT Counter as a non-negative integer
- L0 = length of the WT Counter value (i.e. 0x00 0x02)

The input key shall be K_{eNB} of the eNB.

A.19 Key derivation function for key used in algorithms between UE and SgNB

When deriving ciphering and integrity keys from $S-K_{gNB}$ in the SgNB and UE, the UE and SgNB shall use the KDF given in Annex A.8 of TS 33.501 [43] with $S-K_{gNB}$ as the input key.f

Annex B (normative): Algorithms for ciphering and integrity protection

B.0 Null ciphering and integrity protection algorithms

The EEA0 algorithm shall be implemented such that it has the same effect as if it generates a KEYSTREAM of all zeroes (see subclause B.1.1). The length of the KEYSTREAM generated shall be equal to the LENGTH input parameter. The generated KEYSTREAM requires no other input parameters but the LENGTH. Apart from this, all processing performed in association with ciphering shall be exactly the same as with any of the ciphering algorithms specified in this Annex.

The EIA0 algorithm shall be implemented in such way that it shall generate a 32 bit MAC-I/NAS-MAC and XMAC-I/XNAS-MAC of all zeroes (see subclause B.2.1). Replay protection shall not be activated when EIA0 is activated. All processing performed in association with integrity (except for replay protection) shall be exactly the same as with any of the integrity algorithms specified in this annex except that the receiver does not check the received MAC.

NOTE 1: The reason for mentioning the replay protection here is that replay protection is associated with integrity.

EIA0 shall be used only for emergency calling for unauthenticated UEs in LSM.

NOTE 2: a UE with a 2G SIM is considered to be in LSM in E-UTRAN.

NOTE 3: EEA0 and EIA0 provide no security.

B.1 128-bit ciphering algorithm

B.1.1 Inputs and outputs

The input parameters to the ciphering algorithm are a 128-bit cipher key named KEY, a 32-bit COUNT, a 5-bit bearer identity BEARER, the 1-bit direction of the transmission i.e. DIRECTION, and the length of the keystream required i.e. LENGTH. The DIRECTION bit shall be 0 for uplink and 1 for downlink.

Figure B.1-1 illustrates the use of the ciphering algorithm EEA to encrypt plaintext by applying a keystream using a bit per bit binary addition of the plaintext and the keystream. The plaintext may be recovered by generating the same keystream using the same input parameters and applying a bit per bit binary addition with the ciphertext.

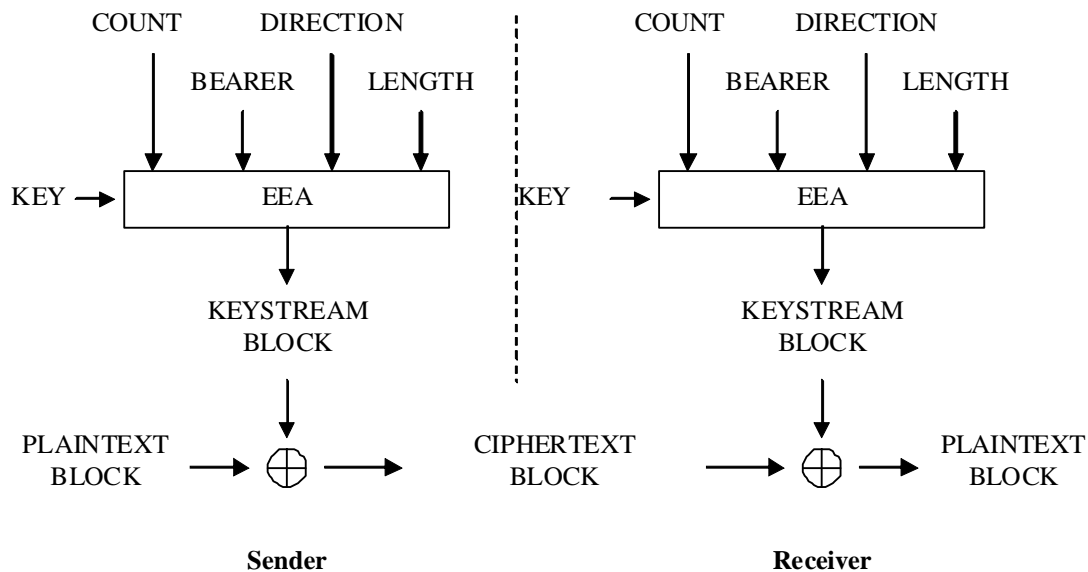

Figure B.1-1: Ciphering of data

Based on the input parameters the algorithm generates the output keystream block KEYSTREAM which is used to encrypt the input plaintext block PLAINTEXT to produce the output ciphertext block CIPHERTEXT.

The input parameter LENGTH shall affect only the length of the KEYSTREAM BLOCK, not the actual bits in it.

B.1.2 128-EEA1

128-EEA1 is based on SNOW 3G and is identical to UEA2 as specified in [14]. The used IV is constructed the same way as in subclause 3.4 of that TS.

B.1.3 128-EEA2

128-EEA2 is based on 128-bit AES [15] in CTR mode [16]

The sequence of 128-bit counter blocks needed for CTR mode $T_1, T_2, \dots, T_i, \dots$ shall be constructed as follows:

The most significant 64 bits of T_1 consist of COUNT[0] .. COUNT[31] | BEARER[0] .. BEARER[4] | DIRECTION | 0^{26} (i.e. 26 zero bits). These are written from most significant on the left to least significant on the right, so for example COUNT[0] is the most significant bit of T_1 .

The least significant 64 bits of T_1 are all 0.

Subsequent counter blocks are then obtained by applying the standard integer incrementing function (according to Appendix B1 in [16]) mod 2^{64} to the least significant 64 bits of the previous counter block.

B.1.4 128-EEA3

128-EEA3 is based on ZUC and specified in [33].

B.2 128-Bit integrity algorithm

B.2.1 Inputs and outputs

The input parameters to the integrity algorithm are a 128-bit integrity key named KEY, a 32-bit COUNT, a 5-bit bearer identity called BEARER, the 1-bit direction of the transmission i.e. DIRECTION, and the message itself i.e. MESSAGE. The DIRECTION bit shall be 0 for uplink and 1 for downlink. The bit length of the MESSAGE is LENGTH.

Figure B.2-1 illustrates the use of the integrity algorithm EIA to authenticate the integrity of messages.

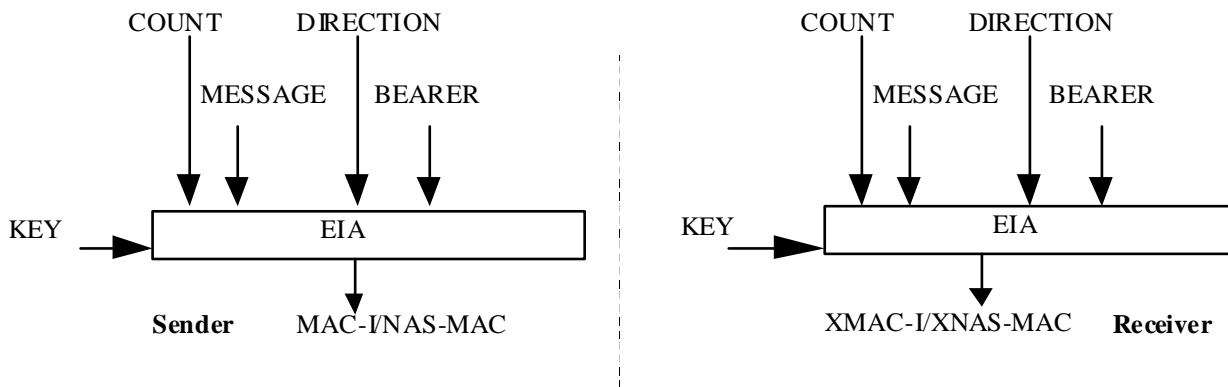

Figure B.2-1: Derivation of MAC-I/NAS-MAC (or XMAC-I/XNAS-MAC)

Based on these input parameters the sender computes a 32-bit message authentication code (MAC-I/NAS-MAC) using the integrity algorithm EIA. The message authentication code is then appended to the message when sent. For integrity protection algorithms other than EIA0 the receiver computes the expected message authentication code (XMAC-I/XNAS-MAC) on the message received in the same way as the sender computed its message authentication code on the message sent and verifies the data integrity of the message by comparing it to the received message authentication code, i.e. MAC-I/NAS-MAC.

B.2.2 128-EIA1

128-EIA1 is based on SNOW 3G and is implemented in the same way as UIA2 as specified in [14]. The used IV is constructed the same way as in subclause 4.4 of that TS, with the only difference being that FRESH [0], ... FRESH [31] shall be replaced by BEARER[0] ... BEARER[4] | 0²⁷ (i.e. 27 zero bits)

B.2.3 128-EIA2

128-EIA2 is based on 128-bit AES [15] in CMAC mode [17].

The bit length of MESSAGE is BLENGTH.

The input to CMAC mode is a bit string M of length Mlen (see [17, section 5.5]). M is constructed as follows:

$M_0 \dots M_{31} = \text{COUNT}[0] \dots \text{COUNT}[31]$

$M_{32} \dots M_{36} = \text{BEARER}[0] \dots \text{BEARER}[4]$

$M_{37} = \text{DIRECTION}$

$M_{38} \dots M_{63} = 0^{26}$ (i.e. 26 zero bits)

$M_{64} \dots M_{\text{BLENGTH}+63} = \text{MESSAGE}[0] \dots \text{MESSAGE}[\text{BLENGTH}-1]$

and so $M_{\text{len}} = \text{BLENGTH} + 64$.

AES in CMAC mode is used with these inputs to produce a Message Authentication Code T (MACT) of length $Tlen = 32$. T is used directly as the 128-EIA2 output MACT[0] .. MACT[31], with MACT[0] being the most significant bit of T.

B.2.4 128-EIA3

128-EIA3 is based on ZUC and specified in [33].

Annex C (informative): Algorithm test data

C.1 128-EEA2

This section includes six test data sets; all are presented in hex, while the first is also presented in binary. Some intermediate computational values are included to assist implementers in tracing bugs. Some notation is taken from the specification of CTR mode [16].

Bit ordering should be largely self explanatory, but in particular:

- The 5-bit BEARER is written in hex in a "right aligned" form, i.e. as a two-hex-digit value in the range 00 to 1F inclusive, with BEARER [0] as the msb of the first digit.
- Similarly the single DIRECTION bit is written in hex in "right aligned" form, i.e. the DIRECTION bit is the lsb of the hex digit.
- Where the length of plaintext and ciphertext is not a multiple of 32 bits, they are written in hex in a "left aligned" form, i.e. the least significant few bits of the last word will be zero.

C.1.1 Test Set 1

Key = (hex) d3c5d592 327fb11c 4035c668 0af8c6d1

Key = (bin) 11010011 11000101 11010101 10010010 00110010 01111111 10110001 00011100
01000000 00110101 11000110 01101000 00001010 11111000 11000110 11010001

Count = (hex) 398a59b4

Count = (bin) 00111001 10001010 01011001 10110100

Bearer = (hex) 15

Bearer = (bin) 10101

Direction = (hex) 1

Direction = (bin) 1

Length = 253 bits

Plaintext = (hex) 981ba682 4c1bfb1a b4854720 29b71d80 8ce33e2c c3c0b5fc 1f3de8a6 dc66b1f0

Plaintext = (bin) 10011000 00011011 10100110 10000010 01001100 00011011 11111011 00011010
10110100 10000101 01000111 00100000 00101001 10110111 00011101 10000000
10001100 11100011 00111110 00101100 11000011 11000000 10110101 11111100
00011111 00111101 11101000 10100110 11011100 01100110 10110001 11110

Counter block T1 = (hex) 398a59b4 ac000000 00000000 00000000

Counter block T1 = (bin) 00111001 10001010 01011001 10110100 10101100 00000000 00000000 00000000
00000000 00000000 00000000 00000000 00000000 00000000 00000000 00000000

Keystream block 1 = (hex) 71e57e24 710ea81e 6398b52b da5f3f94

Keystream block 1 = (bin) 01110001 11100101 01111110 00100100 01110001 00001110 10101000 00011110
 01100011 10011000 10110101 00101011 11011010 01011111 00111111 10010100

Counter block T2 = (hex) 398a59b4 ac000000 00000000 00000001

Counter block T2 = (bin) 00111001 10001010 01011001 10110100 10101100 00000000 00000000 00000000
 00000000 00000000 00000000 00000000 00000000 00000000 00000000 00000001

Keystream block 2 = (hex) 3eede9f6 11328620 231f3f1b 328b3f88

Keystream block 2 = (bin) 00111110 11101101 11101001 11110110 00010001 00110010 10000110 00100000
 00100011 00011111 00111111 00011011 00110010 10001011 00111111 10001000

Ciphertext = (hex) e9fed8a6 3d155304 d71df20b f3e82214 b20ed7da d2f233dc 3c22d7bd eed8e78

Ciphertext = (bin) 11101001 11111110 11011000 10100110 00111101 00010101 01010011 00000100
 11010111 00011101 11110010 00001011 11110011 11101000 00100010 00010100
 10110010 00001110 11010111 11011010 11010010 11110010 00110011 11011100
 00111100 00100010 11010111 10111101 11101110 11101101 10001110 011111

C.1.2 Test Set 2

Key = 2bd6459f 82c440e0 952c4910 4805ff48

Count = c675a64b

Bearer = 0c

Direction = 1

Length = 798 bits

Plaintext = 7ec61272 743bf161 4726446a 6c38ced1 66f6ca76 eb543004 4286346c ef130f92
 922b0345 0d3a9975 e5bd2ea0 eb55ad8e 1b199e3e c4316020 e9a1b285 e7627953
 59b7bdfd 39bef4b2 484583d5 afe082ae e638bf5f d5a60619 3901a08f 4ab41aab
 9b134880

Counter block T1 = c675a64b 64000000 00000000 00000000

Keystream block 1 = 27a77221 27fdbabd e67d5d34 44bd9d78

Counter block T2 = c675a64b 64000000 00000000 00000001

Keystream block 2 = 7695ef70 3d743aa3 d242fc6a 268a0b5d

Counter block T3 = c675a64b 64000000 00000000 00000002

Keystream block 3 = b66ecf15 b626681d 412b5dd3 a55db6d9

Counter block T4 = c675a64b 64000000 00000000 00000003

Keystream block 4 = f83d506c 9df187ad a578c902 ee14296f

Counter block T5 = c675a64b 64000000 00000000 00000004

Keystream block 5 = 50f44f36 635604e0 8ff25047 8c750516

Counter block T6 = c675a64b 64000000 00000000 00000005

Keystream block 6 = 735839e3 7ebe8579 7be34641 08f730bc

Counter block T7 = c675a64b 64000000 00000000 00000006

Keystream block 7 = 8b4f1b53 87da3277 a56f567d 8066fce2

Ciphertext = 59616053 53c64bdc a15b195e 288553a9 10632506 d6200aa7 90c4c806 c99904cf

2445cc50 bb1cf168 a4967373 4e081b57 e324ce52 59c0e78d 4cd97b87 0976503c

0943f2cb 5ae8f052 c7b7d392 239587b8 956086bc ab188360 42e2e6ce 42432a17

105c53d0

C.1.3 Test Set 3

Key = 0a8b6bd8 d9b08b08 d64e32d1 817777fb

Count = 544d49cd

Bearer = 04

Direction = 0

Length = 310 bits

Plaintext = fd40a41d 370a1f65 74509568 7d47ba1d 36d2349e 23f64439 2c8ea9c4 9d40c132

71aff264 d0f24800

Counter block T1 = 544d49cd 20000000 00000000 00000000

Keystream block 1 = 8835a92a 83b1bdc1 aa8ba14b 2691367b

Counter block T2 = 544d49cd 20000000 00000000 00000001

Keystream block 2 = 737eee32 87777c9a 9c4ad826 3a44db65

Counter block T3 = 544d49cd 20000000 00000000 00000002

Keystream block 3 = 158c20f6 a275b8f5 0e8ae073 997c58ed

Ciphertext = 75750d37 b4bba2a4 dedb3423 5bd68c66 45acdaac a48138a3 b0c471e2 a7041a57

6423d292 7287f000

C.1.4 Test Set 4

Key = aa1f95ae a533bcb3 2eb63bf5 2d8f831a

Count = 72d8c671

Bearer = 10

Direction = 1

Length = 1022 bits

Plaintext = fb1b96c5 c8badfb2 e8e8edfd e78e57f2 ad81e741 03fc430a 534dcc37 afcec70e
1517bb06 f27219da e49022dd c47a068d e4c9496a 951a6b09 edbdc864 c7adbd74
0ac50c02 2f3082ba fd22d781 97c5d508 b977bca1 3f32e652 e74ba728 576077ce
628c535e 87dc6077 ba07d290 68590c8c b5f1088e 082cfa0e c961302d 69cf3d44

Counter block T1 = 72d8c671 84000000 00000000 00000000

Keystream block 1 = 24afd669 7bcdeafb 0728abd5 49368fe7

Counter block T2 = 72d8c671 84000000 00000000 00000001

Keystream block 2 = cff4c44a df954e9e e34041a2 5d428c58

Counter block T3 = 72d8c671 84000000 00000000 00000002

Keystream block 3 = 2568dbf2 3827f27c 857b98af 68fa8925

Counter block T4 = 72d8c671 84000000 00000000 00000003

Keystream block 4 = 20576f12 1bca2154 8dd17c7c 19d93aff

Counter block T5 = 72d8c671 84000000 00000000 00000004

Keystream block 5 = 90e7f4ed 0669897e 16751e7b 6001c02c

Counter block T6 = 72d8c671 84000000 00000000 00000005

Keystream block 6 = 11f20436 a370d97d 68c5a2ba fee7e5cf

Counter block T7 = 72d8c671 84000000 00000000 00000006

Keystream block 7 = dcf3aa29 fdca4acf aaf961b4 d22dc84d

Counter block T8 = 72d8c671 84000000 00000000 00000007

Keystream block 8 = e31145b7 015ef36b f3a20e77 36e2b523

Ciphertext = dfb440ac b3773549 efc04628 aeb8d815 6275230b dc690d94 b00d8d95 f28c4b56

307f60f4 ca55eba6 61ebba72 ac808fa8 c49e2678 8ed04a5d 606cb418 de74878b
9a22f8ef 29590bc4 eb57c9fa f7c41524 a885b897 9c423f2f 8f8e0592 a9879201
be7ff977 7a162ab8 10feb324 ba74c4c1 56e04d39 09720965 3ac33e5a 5f2d8864

C.1.5 Test Set 5

Key = 9618ae46 891f8657 8eebe90e f7a1202e

Count = c675a64b

Bearer = 0c

Direction = 1

Length = 1245 bits

Plaintext = 8daa17b1 ae050529 c6827f28 c0ef6a12 42e93f8b 314fb18a 77f790ae 049fedd6

12267fec aefc4501 74d76d9f 9aa7755a 30cd90a9 a5874bf4 8eaf70ee a3a62a25
 0a8b6bd8 d9b08b08 d64e32d1 817777fb 544d49cd 49720e21 9dbf8bbe d33904e1
 fd40a41d 370a1f65 74509568 7d47ba1d 36d2349e 23f64439 2c8ea9c4 9d40c132
 71aff264 d0f24841 d6465f09 96ff84e6 5fc517c5 3efc3363 c38492a8

Counter block T1 = c675a64b 64000000 00000000 00000000

Keystream block 1 = 1c369b82 78628c59 fb87dfff 0e6dc8bc

Counter block T2 = c675a64b 64000000 00000000 00000001

Keystream block 2 = eea7d8e7 3e0211da 44a91a2a e3169673

Counter block T3 = c675a64b 64000000 00000000 00000002

Keystream block 3 = cd094951 ffc2780d f1afaa3f 665736ba

Counter block T4 = c675a64b 64000000 00000000 00000003

Keystream block 4 = 0a6e3336 1f2a36e1 30a83f44 fe3603d2

Counter block T5 = c675a64b 64000000 00000000 00000004

Keystream block 5 = 153f3c6e 9e33cc1c 66afbdc0 febd679c

Counter block T6 = c675a64b 64000000 00000000 00000005

Keystream block 6 = 2d0840a1 c52d3c4a 356982e0 61a53ad7

Counter block T7 = c675a64b 64000000 00000000 00000006

Keystream block 7 = 3264f90b 15a0e1f7 6b25f3ac 8891feef

Counter block T8 = c675a64b 64000000 00000000 00000007

Keystream block 8 = c72e3a58 a72bf62a 65fadfe6 7f49e86f

Counter block T9 = c675a64b 64000000 00000000 00000008

Keystream block 9 = 5650cdf1 b2c13995 4d522303 627993f9

Counter block T10 = c675a64b 64000000 00000000 00000009

Keystream block 10 = 7d081374 f517153b e1bafb97 3f9dd804

Ciphertext = 919c8c33 d6678970 3d05a0d7 ce82a2ae ac4ee76c 0f4da050 335e8a84 e7897ba5

df2f36bd 513e3d0c 8578c7a0 fcf043e0 3aa3a39f baad7d15 be074faa 5d9029f7
 1fb457b6 47834714 b0e18f11 7fca1067 7945096c 8c5f326b a8d6095e b29c3e36
 cf245d16 22aafe92 1f7566c4 f5d644f2 f1fc0ec6 84ddb213 49747622 e209295d
 27ff3f95 623371d4 9b147c0a f486171f 22cd04b1 cbeb2658 223e6938

C.1.6 Test Set 6

Key = 54f4e2e0 4c83786e ec8fb5ab e8e36566

Count = aca4f50f

Bearer = 0b

Direction = 0

Length = 3861 bits

Plaintext = 40981ba6 824c1bfb 4286b299 783daf44 2c099f7a b0f58d5c 8e46b104 f08f01b4
1ab48547 2029b71d 36bd1a3d 90dc3a41 b46d5167 2ac4c966 3a2be063 da4bc8d2
808ce33e 2cccbfc6 34e1b259 060876a0 fbb5a437 ebcc8d31 c19e4454 318745e3
fa16bb11 adae2488 79fe52db 2543e53c f445d3d8 28ce0bf5 c560593d 97278a59
762dd0c2 c9cd68d4 496a7925 08614014 b13b6aa5 1128c18c d6a90b87 978c2ff1
cabe7d9f 898a411b fdb84f68 f6727b14 99cdd30d f0443ab4 a6665333 0bcba110
5e4cec03 4c73e605 b4310eaa adcf5b0 ca27ffd8 9d144df4 79275942 7c9cc1f8
cd8c8720 2364b8a6 87954cb0 5a8d4e2d 99e73db1 60deb180 ad0841e9 6741a5d5
9fe4189f 15420026 fe4cd121 04932fb3 8f735340 438aaf7e ca6fd5cf d3a195ce
5abe6527 2af607ad a1be65a6 b4c9c069 3234092c 4d018f17 56c6db9d c8a6d80b
88813861 6b681262 f954d0e7 71174878 0d92291d 86299972 db741cfa 4f37b8b5
6cdb18a7 ca8218e8 6e4b4b71 6a4d0437 1fbec262 fc5ad0b3 819b187b 97e55b1a
4d7c19ee 24c8b4d7 723cfedf 045b8aca e4869517 d80e5061 5d9035d5 d9c5a40a
f602280b 542597b0 cb18619e eb359257 59d195e1 00e8e4aa 0c38a3c2 abe0f3d8
ff04f3c3 3c295069 c23694b5 bbeacdd5 42e28e8a 94edb911 9f412d05 4be1fa72
00b09000

Counter block T1 = aca4f50f 58000000 00000000 00000000

Keystream block 1 = 1c2f37c8 5ecb94ee 2467b0ca d7fecb8d

Counter block T2 = aca4f50f 58000000 00000000 00000001

Keystream block 2 = d65d92eb fd4cc1e2 6c336195 8c29aeb9

Counter block T3 = aca4f50f 58000000 00000000 00000002

Keystream block 3 = 6d1831a8 1b97ad6f 1d93ef80 8d97b46b

Counter block T4 = aca4f50f 58000000 00000000 00000003

Keystream block 4 = 116f1fa6 124ee978 41e59943 748ddd5b

Counter block T5 = aca4f50f 58000000 00000000 00000004

Keystream block 5 = dffad96b 48107b02 b6435c44 8df6bae4

Counter block T6 = aca4f50f 58000000 00000000 00000005

Keystream block 6 = 63590c08 50b9749a 929049fb 8f596a46

Counter block T7 = aca4f50f 58000000 00000000 00000006

Keystream block 7 = 734d3988 b6cc534d 501ea089 b83c9c5c

Counter block T8 = aca4f50f 58000000 00000000 00000007

Keystream block 8 = 9facb4de 01a3e60f 58144b8b 81b206ec
Counter block T9 = aca4f50f 58000000 00000000 00000008
Keystream block 9 = 15eba802 e1e8abd9 43840ee1 c9279262
Counter block T10 = aca4f50f 58000000 00000000 00000009
Keystream block 10 = e52928bf 91a5d242 1eb062cb e22178df
Counter block T11 = aca4f50f 58000000 00000000 0000000a
Keystream block 11 = 5129400b 020be828 8183657f ef5c59d6
Counter block T12 = aca4f50f 58000000 00000000 0000000b
Keystream block 12 = 9f52addc e66ecef8 78ce4453 3dae4917
Counter block T13 = aca4f50f 58000000 00000000 0000000c
Keystream block 13 = 900c24e3 91ee8591 685f3fbf 922e40ec
Counter block T14 = aca4f50f 58000000 00000000 0000000d
Keystream block 14 = 8d884ac7 bb03a3f8 271cd7b3 d1e9b515
Counter block T15 = aca4f50f 58000000 00000000 0000000e
Keystream block 15 = f9b25b07 60a82c6f 1774bd4d 7ccf1dec
Counter block T16 = aca4f50f 58000000 00000000 0000000f
Keystream block 16 = e1399a88 a0604f6b 6097da9f b3ddb5c0
Counter block T17 = aca4f50f 58000000 00000000 00000010
Keystream block 17 = 561ad7cf f0798b74 fa971c1f e91517e6
Counter block T18 = aca4f50f 58000000 00000000 00000011
Keystream block 18 = 55cf8f89 08bb4c66 c87abd4a 8f2a0b9c
Counter block T19 = aca4f50f 58000000 00000000 00000012
Keystream block 19 = f33ff05d 3bde2054 d904f3a9 a08e5172
Counter block T20 = aca4f50f 58000000 00000000 00000013
Keystream block 20 = 034f5c3d b6cdf0a6 6c078846 bc83c91c
Counter block T21 = aca4f50f 58000000 00000000 00000014
Keystream block 21 = 6c0726d8 8353ed9d 3dbfa7b2 2687709d
Counter block T22 = aca4f50f 58000000 00000000 00000015
Keystream block 22 = 74b698ea 0d1783ab d0df36fd c82cca6e
Counter block T23 = aca4f50f 58000000 00000000 00000016
Keystream block 23 = 32348e64 fe86518e b5477cbb 97578dd2
Counter block T24 = aca4f50f 58000000 00000000 00000017
Keystream block 24 = 7bd4f7e2 173eb542 a047f1b0 1f3d008c
Counter block T25 = aca4f50f 58000000 00000000 00000018
Keystream block 25 = 825fd522 f0e0b3b0 ccd4106d 39ddd88c

Counter block T26 = aca4f50f 58000000 00000000 00000019
Keystream block 26 = f930dc26 db0e6bce d465d457 b82fe7c2
Counter block T27 = aca4f50f 58000000 00000000 0000001a
Keystream block 27 = bc90c3f4 abc1072d 0f74300c 13106527
Counter block T28 = aca4f50f 58000000 00000000 0000001b
Keystream block 28 = 39da03e3 c5bf5152 b809045f ee778e01
Counter block T29 = aca4f50f 58000000 00000000 0000001c
Keystream block 29 = 3b1f75fe 95c81280 c2165b65 cf3c5fae
Counter block T30 = aca4f50f 58000000 00000000 0000001d
Keystream block 30 = 385138f8 c9f7d62e 07f8e4df e379d08d
Counter block T31 = aca4f50f 58000000 00000000 0000001e
Keystream block 31 = 06c8b899 06c71bb9 2e834ee7 e81cd109

Ciphertext = 5cb72c6e dc878f15 66e10253 afc364c9 fa540d91 4db94cbe e275d091 7ca6af0d

77acb4ef 3bbe1a72 2b2ef5bd 1d4b8e2a a5024ec1 388a201e 7bce7920 aec61589
5f763a55 64dcc4c4 82a2ee1d 8bfec44 98eca83f bb75f9ab 530e0daf bede2fa5
895b8299 1b6277c5 29e0f252 9d7f7960 6be96706 296dedfa 9d7412b6 16958cb5
63c678c0 2825c30d 0aee77c4 c146d276 5412421a 808d13ce c819694c 75ad572e
9b973d94 8b81a933 7c3b2a17 192e22c2 069f7ed1 162af44c dea81760 3665e807
ce40c8e0 dd9d6394 dc6e3115 3fe1955c 47afb51f 2617ee0c 5e3b8ef1 ad7574ed
343edc27 43cc94c9 90e1f1fd 264253c1 78dea739 c0befeeb cd9f9b76 d49c1015
c9fecf50 e53b8b52 04dbcd3e ed863855 dabcdcc9 4b31e318 02156885 5c8b9e52
a981957a 112827f9 78ba960f 1447911b 317b5511 fbcc7fb1 3ac153db 74251117
e4861eb9 e83bffff c4eb7755 579038e5 7924b1f7 8b3e1ad9 0bab2a07 871b72db
5eef96c3 34044966 db0c37ca fd1a89e5 646a3580 eb6465f1 21dce9cb 88d85b96
cf23cccc d4280767 bee8eeb2 3d865246 1db64931 03003baf 89f5e182 61ea43c8
4a92ebff ffe4909d c46c5192 f825f770 600b9602 c557b5f8 b431a79d 45977dd9
c41b863d a9e142e9 0020cfd0 74d6927b 7ab3b672 5d1a6f3f 98b9c9da a8982aff
06782800

C.2 128-EIA2

This section includes eight test data sets; all are presented in hex, while the first is also presented in binary. Many intermediate computational values are included to assist implementers in tracing bugs. Some notation is taken from the specification of CMAC mode [17].

Bit ordering should be largely self explanatory, but in particular:

- The 5-bit BEARER is written in hex in a "right aligned" form, i.e. as a two-hex-digit value in the range 00 to 1F inclusive, with BEARER [0] as the msb of the first digit.
- Similarly the single DIRECTION bit is written in hex in "right aligned" form, i.e. the DIRECTION bit is the lsb of the hex digit.
- Where the length of the message, or of a message sub-block, is not a multiple of 32 bits, it is written in hex in a "left aligned" form, i.e. the least significant few bits of the last word will be zero.

NOTE: This section provides both byte aligned and non byte aligned test data sets. For EPS implementation verification, byte alignment test data sets (2, 5 and 8) can be used, as EPS RRC and EPS NAS messages are byte aligned. The non byte aligned test data sets may be used to verify implementations that support non byte aligned messages.

C.2.1 Test Set 1

Count-I = (hex) 38a6f056

Count-I = (bin) 00111000 10100110 11110000 01010110

Bearer = (hex) 18

Bearer = (bin) 11000

Direction = (hex) 0

Direction = (bin) 0

IK = (hex) 2bd6459f 82c5b300 952c4910 4881ff48

IK = (bin) 00101011 11010110 01000101 10011111 10000010 11000101 10110011 00000000
10010101 00101100 01001001 00010000 01001000 10000001 11111111 01001000

Length = 58 bits

Message = (hex) 33323462 63393840

Message = (bin) 00110011 00110010 00110100 01100010 01100011 00111001 00111000 01

CMAC(K, M):

K = (hex) 2bd6459f 82c5b300 952c4910 4881ff48

K = (bin) 00101011 11010110 01000101 10011111 10000010 11000101 10110011 00000000
10010101 00101100 01001001 00010000 01001000 10000001 11111111 01001000

Mlen = 122

M = (hex) 38a6f056 c0000000 33323462 63393840

M = (bin) 00111000 10100110 11110000 01010110 11000000 00000000 00000000 00000000
00110011 00110010 00110100 01100010 01100011 00111001 00111000 01

Subkey Generation:

L = (hex) 6e426138 5adfc1fc b7c85f0c 469fb20c

L = (bin) 01101110 01000010 01100001 00111000 01011010 11011111 11000001 11111100
10110111 11001000 01011111 00001100 01000110 10011111 10110010 00001100

K1 = (hex) dc84c270 b5bf83f9 6f90be18 8d3f6418
 K1 = (bin) 11011100 10000100 11000010 01110000 10110101 10111111 10000011 11111001
 01101111 10010000 10111110 00011000 10001101 00111111 01100100 00011000
 K2 = (hex) b90984e1 6b7f07f2 df217c31 1a7ec8b7
 K2 = (bin) 10111001 00001001 10000100 11100001 01101011 01111111 00000111 11110010
 11011111 00100001 01111100 00110001 00011010 01111110 11001000 10110111

MAC Generation:

n = 1
 Mn* = (hex) 38a6f056 c0000000 33323462 63393840
 Mn* = (bin) 00111000 10100110 11110000 01010110 11000000 00000000 00000000 00000000
 00110011 00110010 00110100 01100010 01100011 00111001 00111000 01
 Mn = (hex) 81af74b7 ab7f07f2 ec134853 7947f0d7
 Mn = (bin) 10000001 10101111 01110100 10110111 10101011 01111111 00000111 11110010
 11101100 00010011 01001000 01010011 01111001 01000111 11110000 11010111
 C0 = (hex) 00000000 00000000 00000000 00000000
 C0 = (bin) 00000000 00000000 00000000 00000000 00000000 00000000 00000000 00000000
 00000000 00000000 00000000 00000000 00000000 00000000 00000000 00000000
 M1 = (hex) 81af74b7 ab7f07f2 ec134853 7947f0d7
 M1 = (bin) 10000001 10101111 01110100 10110111 10101011 01111111 00000111 11110010
 11101100 00010011 01001000 01010011 01111001 01000111 11110000 11010111
 C1 = (hex) 118c6eb8 b775144b 0b831110 54c96eb6
 C1 = (bin) 00010001 10001100 01101110 10111000 10110111 01110101 00010100 01001011
 00001011 10000011 00010001 00010000 01010100 11001001 01101110 10110110

MACT = (hex) 118c6eb8

MACT = (bin) 00010001 10001100 01101110 10111000

C.2.2 Test Set 2

Count-I = 398a59b4

Bearer = 1a

Direction = 1

IK = d3c5d592 327fb11c 4035c668 0af8c6d1

Length = 64 bits

Message = 484583d5 afe082ae

CMAC(K, M):

K = d3c5d592 327fb11c 4035c668 0af8c6d1

Mlen = 128

M = 398a59b4 d4000000 484583d5 afe082ae

Subkey Generation:

L = 9b71f299 132915d3 605211b5 e5df8632

K1 = 36e3e532 26522ba6 c0a4236b cbbf0ce3

K2 = 6dc7ca64 4ca4574d 814846d7 977e19c6

MAC Generation:

n = 1

Mn* = 398a59b4 d4000000 484583d5 afe082ae

Mn = 0f69bc86 f2522ba6 88e1a0be 645f8e4d

C0 = 00000000 00000000 00000000 00000000

M1 = 0f69bc86 f2522ba6 88e1a0be 645f8e4d

C1 = b93787e6 493ff113 ad73d3e0 1e826d73

MACT = b93787e6

C.2.3 Test Set 3

Count-I = 36af6144

Bearer = 18

Direction = 1

IK = 7e5e9443 1e11d738 28d739cc 6ced4573

Length = 254 bits

Message = b3d3c917 0a4e1632 f60f8610 13d22d84 b726b6a2 78d802d1 eeaf1321 ba5929dc

CMAC(K, M):

K = 7e5e9443 1e11d738 28d739cc 6ced4573

Mlen = 318

M = 36af6144 c4000000 b3d3c917 0a4e1632 f60f8610 13d22d84 b726b6a2 78d802d1
eeaf1321 ba5929dc

Subkey Generation:

L = d78b4628 35781e79 d2255f8d 309a60ef
 K1 = af168c50 6af03cf3 a44abf1a 6134c159
 K2 = 5e2d18a0 d5e079e7 48957e34 c2698235

MAC Generation:

n = 3
 Mn* = eeaf1321 ba5929dc
 Mn = b0820b81 6fb95039 48957e34 c2698235
 C0 = 00000000 00000000 00000000 00000000
 M1 = 36af6144 c4000000 b3d3c917 0a4e1632
 C1 = 3bb0e1d8 2cb96273 64a7cf3d a52eed15
 M2 = f60f8610 13d22d84 b726b6a2 78d802d1
 C2 = e3a6446d fae7f10f e3e3320d a8e49955
 M3 = b0820b81 6fb95039 48957e34 c2698235
 C3 = 1f60b01d e05aa666 3bda32c6 1771e70b

MACT = 1f60b01d

C.2.4 Test Set 4

Count-I = c7590ea9

Bearer = 17

Direction = 0

IK = d3419be8 21087acd 02123a92 48033359

Length = 511 bits

Message = bbb05703 8809496b cff86d6f bc8ce5b1 35a06b16 6054f2d5 65be8ace 75dc851e
 0bcdd8f0 7141c495 872fb5d8 c0c66a8b 6da55666 3e4e4612 05d84580 bee5bc7e

CMAC(K, M):

K = d3419be8 21087acd 02123a92 48033359

Mlen = 575

M = c7590ea9 b8000000 bbb05703 8809496b cff86d6f bc8ce5b1 35a06b16 6054f2d5
 65be8ace 75dc851e 0bcdd8f0 7141c495 872fb5d8 c0c66a8b 6da55666 3e4e4612
 05d84580 bee5bc7e

Subkey Generation:

L = 054dd008 2d9ecd21 a3f32b0a a7369be4
K1 = 0a9ba010 5b3d9a43 47e65615 4e6d37c8
K2 = 15374020 b67b3486 8fccac2a 9cda6f90

MAC Generation:

n = 5
Mn* = 05d84580 bee5bc7e
Mn = 10ef05a0 089e88f9 8fccac2a 9cda6f90
C0 = 00000000 00000000 00000000 00000000
M1 = c7590ea9 b8000000 bbb05703 8809496b
C1 = cb36ed77 e49bd772 ac410f25 eea31084
M2 = cff86d6f bc8ce5b1 35a06b16 6054f2d5
C2 = e44baf91 d48ba92c 542f3b14 a8a496d9
M3 = 65be8ace 75dc851e 0bccd8f0 7141c495
C3 = c3542869 eed00692 e3b4ef1a 6b324aaf
M4 = 872fb5d8 c0c66a8b 6da55666 3e4e4612
C4 = 5054d998 92675b0f 989d3b0f 3c043c4e
M5 = 10ef05a0 089e88f9 8fccac2a 9cda6f90
C5 = 6846a2f0 a0b6be7a 4fb26a15 7e914c53

MACT = 6846a2f0

C.2.5 Test Set 5

Count-I = 36af6144

Bearer = 0f

Direction = 1

IK = 83fd23a2 44a74cf3 58da3019 f1722635

Length = 768 bits

Message = 35c68716 633c66fb 750c2668 65d53c11 ea05b1e9 fa49c839 8d48e1ef a5909d39
47902837 f5ae96d5 a05bc8d6 1ca8dbef 1b13a4b4 abfe4fb1 006045b6 74bb5472
9304c382 be53a5af 05556176 f6eaa2ef 1d05e4b0 83181ee6 74cda5a4 85f74d7a

CMAC(K, M):

K = 83fd23a2 44a74cf3 58da3019 f1722635

Mlen = 832

M = 36af6144 7c000000 35c68716 633c66fb 750c2668 65d53c11 ea05b1e9 fa49c839
8d48e1ef a5909d39 47902837 f5ae96d5 a05bc8d6 1ca8dbef 1b13a4b4 abfe4fb1
006045b6 74bb5472 9304c382 be53a5af 05556176 f6eaa2ef 1d05e4b0 83181ee6
74cda5a4 85f74d7a

Subkey Generation:

L = 9df61c57 3c86acac 704db9d5 b0dea444
K1 = 3bec38ae 790d5958 e09b73ab 61bd480f
K2 = 77d8715c f21ab2b1 c136e756 c37a901e

MAC Generation:

n = 7
Mn* = 74cda5a4 85f74d7a
Mn = 0315d4f8 77edffcb 4136e756 c37a901e
C0 = 00000000 00000000 00000000 00000000
M1 = 36af6144 7c000000 35c68716 633c66fb
C1 = 57c5a916 e19d7747 c2a69283 5eed0015
M2 = 750c2668 65d53c11 ea05b1e9 fa49c839
C2 = 7937651c b2c34e23 646b4396 f77bca0d
M3 = 8d48e1ef a5909d39 47902837 f5ae96d5
C3 = dfa3c570 d7b4dd08 2533b643 f82f646c
M4 = a05bc8d6 1ca8dbef 1b13a4b4 abfe4fb1
C4 = 7a8e64c0 eb34df52 e4236368 0f019ddd
M5 = 006045b6 74bb5472 9304c382 be53a5af
C5 = 3f5f08a2 5a6a8ba8 9a5dd816 626a26ef
M6 = 05556176 f6eaa2ef 1d05e4b0 83181ee6
C6 = 9fe7991a 50c5f542 e0bf0da0 9dec1456
M7 = 0315d4f8 77edffcb 4136e756 c37a901e
C7 = e657e182 5298f2fa ee2ca1e0 7373bc7e

MACT = e657e182

C.2.6 Test Set 6

Count-I = 36af6144

Bearer = 18

Direction = 0

IK = 6832a65c ff447362 1ebdd4ba 26a921fe

Length = 383 bits

Message = d3c53839 62682071 77656676 20323837 63624098 1ba6824c 1bfb1ab4 85472029
b71d808c e33e2cc3 c0b5fc1f 3de8a6dc

CMAC(K, M):

K = 6832a65c ff447362 1ebdd4ba 26a921fe

Mlen = 447

M = 36af6144 c0000000 d3c53839 62682071 77656676 20323837 63624098 1ba6824c
1bfb1ab4 85472029 b71d808c e33e2cc3 c0b5fc1f 3de8a6dc

Subkey Generation:

L = e50123c3 87e13fd6 8d8bf0d0 a4581685

K1 = ca024787 0fc27fad 1b17e1a1 48b02d8d

K2 = 94048f0e 1f84ff5a 362fc342 91605b9d

MAC Generation:

n = 4

Mn* = c0b5fc1f 3de8a6dc

Mn = 54b17311 226c5987 362fc342 91605b9d

C0 = 00000000 00000000 00000000 00000000

M1 = 36af6144 c0000000 d3c53839 62682071

C1 = 263dd98f beccb69a 428e92d4 21fbed9e

M2 = 77656676 20323837 63624098 1ba6824c

C2 = 1838cb78 cb2d32dc ec486c79 d9007a19

M3 = 1bfb1ab4 85472029 b71d808c e33e2cc3

C3 = 5ebf1009 f663be7b 68373072 4c20271f

M4 = 54b17311 226c5987 362fc342 91605b9d

C4 = f0668c1e 4197300b 1243f834 25d06c25

MACT = f0668c1e

C.2.7 Test Set 7

Count-I = 7827fab2

Bearer = 05

Direction = 1

IK = 5d0a80d8 134ae196 77824b67 1e838af4

Length = 2558 bits

Message = 70dedf2d c42c5cbd 3a96f8a0 b11418b3 608d5733 604a2cd3 6aabc70c e3193bb5

153be2d3 c06dfdb2 d16e9c35 7158be6a 41d6b861 e491db3f bfeb518e fcf048d7
d5895373 0ff30c9e c470ffcd 663dc342 01c36add c0111c35 b38afee7 cfdb582e
3731f8b4 baa8d1a8 9c06e811 99a97162 27be344e fcb436dd d0f096c0 64c3b5e2
c399993f c77394f9 e09720a8 11850ef2 3b2ee05d 9e617360 9d86e1c0 c18ea51a
012a00bb 413b9cb8 188a703c d6bae31c c67b34b1 b00019e6 a2b2a690 f02671fe
7c9ef8de c0094e53 3763478d 58d2c5f5 b827a014 8c5948a9 6931acf8 4f465a64
e62ce740 07e991e3 7ea823fa 0fb21923 b79905b7 33b631e6 c7d6860a 3831ac35
1a9c730c 52ff72d9 d308eedb ab21fde1 43a0ea17 e23edc1f 74cbb363 8a2033aa
a15464ea a733385d bbeb6fd7 3509b857 e6a419dc a1d8907a f977fbac 4dfa35ec

CMAC(K, M):

K = 5d0a80d8 134ae196 77824b67 1e838af4

Mlen = 2622

M = 7827fab2 2c000000 70dedf2d c42c5cbd 3a96f8a0 b11418b3 608d5733 604a2cd3
6aabc70c e3193bb5 153be2d3 c06dfdb2 d16e9c35 7158be6a 41d6b861 e491db3f
bfeb518e fcf048d7 d5895373 0ff30c9e c470ffcd 663dc342 01c36add c0111c35
b38afee7 cfdb582e 3731f8b4 baa8d1a8 9c06e811 99a97162 27be344e fcb436dd
d0f096c0 64c3b5e2 c399993f c77394f9 e09720a8 11850ef2 3b2ee05d 9e617360
9d86e1c0 c18ea51a 012a00bb 413b9cb8 188a703c d6bae31c c67b34b1 b00019e6
a2b2a690 f02671fe 7c9ef8de c0094e53 3763478d 58d2c5f5 b827a014 8c5948a9
6931acf8 4f465a64 e62ce740 07e991e3 7ea823fa 0fb21923 b79905b7 33b631e6
c7d6860a 3831ac35 1a9c730c 52ff72d9 d308eedb ab21fde1 43a0ea17 e23edc1f
74cbb363 8a2033aa a15464ea a733385d bbeb6fd7 3509b857 e6a419dc a1d8907a
f977fbac 4dfa35ec

Subkey Generation:

L = 9832e229 fbb93970 bcf7b282 3ee4fe5d

K1 = 3065c453 f77272e1 79ef6504 7dc9fc3d

K2 = 60cb88a7 eee4e5c2 f3deca08 fb93f87a

MAC Generation:

n = 21

Mn* = f977fbac 4dfa35ec

Mn = 99bc730b a31ed02c f3deca08 fb93f87a

C0 = 00000000 00000000 00000000 00000000

M1 = 7827fab2 2c000000 70dedf2d c42c5cbd

C1 = 6c9b07c0 35b7a016 3aad1405 1f57f3e0

M2 = 3a96f8a0 b11418b3 608d5733 604a2cd3

C2 = ec9c6b75 1d027216 3412fad4 f01cebba

M3 = 6aabc70c e3193bb5 153be2d3 c06dfdb2

C3 = 3c83db67 ff87c86b 57ae4742 42c9816b

M4 = d16e9c35 7158be6a 41d6b861 e491db3f

C4 = e6e894ee 7e148494 44afcb75 9752e555

M5 = bfeb518e fcf048d7 d5895373 0ff30c9e

C5 = cbf27df1 0fd514f0 489dd303 d2dbee51

M6 = c470ffcd 663dc342 01c36add c0111c35

C6 = 6989143a 39de09ab 2680fe6c 41f0a7c1

M7 = b38afee7 cfdb582e 3731f8b4 baa8d1a8

C7 = fe4049fa 655ee010 49299c58 c91024ff

M8 = 9c06e811 99a97162 27be344e fcb436dd

C8 = 1e9dab32 48d5ee47 c7e3a420 6f18b17b

M9 = d0f096c0 64c3b5e2 c399993f c77394f9

C9 = 9da578a5 00a0c7f1 e825a4ca 71557055

M10 = e09720a8 11850ef2 3b2ee05d 9e617360

C10 = 4141c882 a23da353 2b11642a 85fea2bf

M11 = 9d86e1c0 c18ea51a 012a00bb 413b9cb8

C11 = 18467572 0bdfcb5b 6bb71899 a6cafcc7

M12 = 188a703c d6bae31c c67b34b1 b00019e6

C12 = 156a70e5 af77f9a4 74d08303 e8c0412a

M13 = a2b2a690 f02671fe 7c9ef8de c0094e53

C13 = dba504a1 26fa047f 8b8c295f 73e90a5c

M14 = 3763478d 58d2c5f5 b827a014 8c5948a9

C14 = ab1a2703 3472acc8 e36c221b b7a0e530
M15 = 6931acf8 4f465a64 e62ce740 07e991e3
C15 = 04ceffcd e7618885 43c7e837 0f3bce6d
M16 = 7ea823fa 0fb21923 b79905b7 33b631e6
C16 = 215ec3bf 5f3a303e 53db5269 e6c99fc2
M17 = c7d6860a 3831ac35 1a9c730c 52ff72d9
C17 = 8622e51b 45a660f3 d98fcf74 e5cc36b3
M18 = d308eedb ab21fde1 43a0ea17 e23edc1f
C18 = 6e998fa6 196d5a4c 1ded2973 c09c0f8c
M19 = 74cbb363 8a2033aa a15464ea a733385d
C19 = 1710bc91 22e54289 244a87ce 23438f41
M20 = bbeb6fd7 3509b857 e6a419dc a1d8907a
C20 = 3e18b029 a8ef18da b9968614 96552fd7
M21 = 99bc730b a31ed02c f3deca08 fb93f87a
C21 = f4cc8fa3 59e6e2e7 6e09c45d 6ea5e0de

MACT = f4cc8fa3

C.2.8 Test Set 8

Count-I = 296f393c

Bearer = 0b

Direction = 1

IK = b3120ffd b2cf6af4 e73eaf2e f4ebec69

Length = 16448 bits

Message = 00000000 00000000 01010101 01010101 e0958045 f3a0bba4 e3968346 f0a3b8a7
c02a018a e6407652 26b987c9 13e6cbf0 83570016 cf83efbc 61c08251 3e21561a
427c009d 28c298ef ace78ed6 d56c2d45 05ad032e 9c04dc60 e73a8169 6da665c6
c48603a5 7b45ab33 221585e6 8ee31691 87fb0239 528632dd 656c807e a3248b7b
46d002b2 b5c7458e b85b9ce9 5879e034 0859055e 3b0abb3c eace8719 caa80265
c97205d5 dc4bcc90 2fe18396 29ed7132 8a0f0449 f588557e 6898860e 042aecdb
4b2404c2 12c9222d a5bf8a89 ef679787 0cf50771 a60f66a2 ee628536 57addf04
cdde07fa 414e11f1 2b4d81b9 b4e8ac53 8ea30666 688d881f 6c348421 992f31b9
4f8806ed 8fccff4c 9123b896 42527ad6 13b109bf 75167485 f1268bf8 84b4cd23
d29a0934 925703d6 34098f77 67f1be74 91e708a8 bb949a38 73708aef 4a36239e
50cc0823 5cd5ed6b be578668 a17b58c1 171d0b90 e813a9e4 f58a89d7 19b11042

d6360b1b 0f52deb7 30a58d58 faf46315 954b0a87 26914759 77dc88c0 d733feff
54600a0c c1d0300a aae9457 2c6e95b0 1ae90de0 4f1dce47 f87e8fa7 bebf77e1
dbc20d6b a85cb914 3d518b28 5dfa04b6 98bf0cf7 819f20fa 7a288eb0 703d995c
59940c7c 66de57a9 b70f8237 9b70e203 1e450fcf d2181326 fcd28d88 23baaa80
df6e0f44 35596475 39fd8907 c0ffd9d7 9c130ed8 1c9afd9b 7e848c9f ed38443d
5d380e53 fdbb8ac8 c3d3f068 76054f12 2461107d e92fea09 c6f6923a 188d53af
e54a10f6 0e6e9d5a 03d996b5 fbc820f8 a637116a 27ad04b4 44a0932d d60fbd12
671c11e1 c0ec73e7 89879faa 3d42c64d 20cd1252 742a3768 c25a9015 85888ece
e1e612d9 936b403b 0775949a 66cdfd99 a29b1345 baa8d9d5 400c9102 4b0a6073
63b013ce 5de9ae86 9d3b8d95 b0570b3c 2d391422 d32450cb cfae9665 2286e96d
ec1214a9 34652798 0a8192ea c1c39a3a af6f1535 1da6be76 4df89772 ec0407d0
6e4415be fae7c925 80df9bf5 07497c8f 2995160d 4e218daa cb02944a bf83340c
e8be1686 a960faf9 0e2d90c5 5cc6475b abc3171a 80a36317 4954955d 7101dab1
6ae81791 67e21444 b443a9ea aa7c91de 36d118c3 9d389f8d d4469a84 6c9a262b
f7fa1848 7a79e8de 11699e0b 8fdf557c b48719d4 53ba7130 56109b93 a218c896
75ac195f b4fb0663 9b379714 4955b3c9 327d1aec 003d42ec d0ea98ab f19ffb4a
f3561a67 e77c35bf 15c59c24 12da881d b02b1bfb cebfac51 52bc99bc 3f1d15f7
71001b70 29fedb02 8f8b852b c4407eb8 3f891c9c a733254f dd1e9edb 56919ce9
fea21c17 4072521c 18319a54 b5d4efbe bddf1d8b 69b1cbf2 5f489fcc 98137254
7cf41d00 8ef0bca1 926f934b 735e090b 3b251eb3 3a36f82e d9b29cf4 cb944188
fa0e1e38 dd778f7d 1c9d987b 28d132df b9731fa4 f4b41693 5be49de3 0516af35
78581f2f 13f561c0 66336194 1eab249a 4bc123f8 d15cd711 a956a1bf 20fe6eb7
8aea2373 361da042 6c79a530 c3bb1de0 c99722ef 1fde39ac 2b00a0a8 ee7c800a
08bc2264 f89f4eff e627ac2f 0531fb55 4f6d21d7 4c590a70 adfaa390 bdfbb3d6
8e46215c ab187d23 68d5a71f 5ebec081 cd3b20c0 82dbe4cd 2faca287 73795d6b
0c10204b 659a939e f29bbe10 88243624 429927a7 eb576dd3 a00ea5e0 1af5d475
83b2272c 0c161a80 6521a16f f9b0a722 c0cf26b0 25d5836e 2258a4f7 d4773ac8
01e4263b c294f43d ef7fa870 3f3a4197 46352588 7652b0b2 a4a2a7cf 87f00914
871e2503 9113c7e1 618da340 64b57a43 c463249f b8d05e0f 26f4a6d8 4972e7a9
05482414 5f91295c db39a6f 920facc6 59712b46 a54ba295 bbe6a901 54e91b33
985a2bcd 420ad5c6 7ec9ad8e b7ac6864 db272a51 6bc94c28 39b0a816 9a6bf58e
1a0c2ada 8c883b7b f497a491 71268ed1 5ddd2969 384e7ff4 bf4aab2e c9ecc652
9cf629e2 df0f08a7 7a65afa1 2aa9b505 df8b287e f6cc9149 3d1caa39 076e28ef
1ea028f5 118de61a e02bb6ae fc3343a0 50292f19 9f401857 b2bead5e 6ee2a1f1
91022f92 78016f04 7791a9d1 8da7d2a6 d27f2e0e 51c2f6ea 30e8ac49 a0604f4c

13542e85 b68381b9 fdcfa0ce 4b2d3413 54852d36 0245c536 b612af71 f3e77c90
95ae2dbd e504b265 733dabfe 10a20fc7 d6d32c21 ccc72b8b 3444ae66 3d65922d
17f82caa 2b865cd8 8913d291 a6589902 6ea13284 39723c19 8c36b0c3 c8d085bf
af8a320f de334b4a 4919b44c 2b95f6e8 ecf73393 f7f0d2a4 0e60b1d4 06526b02
2ddc3318 10b1a5f7 c347bd53 ed1f105d 6a0d30ab a477e178 889ab2ec 55d558de
ab263020 4336962b 4db5b663 b6902b89 e85b31bc 6af50fc5 0accb3fb 9b57b663
29703137 8db47896 d7fbaf6c 600add2c 67f936db 037986db 856eb49c f2db3f7d
a6d23650 e438f188 4041b013 119e4c2a e5af37cc cdfb6866 0738b58b 3c59d1c0
24843747 2aba1f35 ca1fb90c d714aa9f 635534f4 9e7c5bba 81c2b6b3 6fdee21c
a27e347f 793d2ce9 44edb23c 8c9b914b e10335e3 50feb507 0394b7a4 a15c0ca1
20283568 b7bfc254 fe838b13 7a2147ce 7c113a3a 4d65499d 9e86b87d bcc7f03b
bd3a3ab1 aa243ece 5ba9bcf2 5f82836c fe473b2d 83e7a720 1cd0b96a 72451e86
3f6c3ba6 64a6d073 d1f7b5ed 990865d9 78bd3815 d06094fc 9a2aba52 21c22d5a
b996389e 3721e3af 5f05bedd c2875e0d faeb3902 1ee27a41 187cbb45 ef40c3e7
3bc03989 f9a30d12 c54ba7d2 141da8a8 75493e65 776ef35f 97debc22 86cc4af9
b4623eee 902f840c 52f1b8ad 658939ae f71f3f72 b9ec1de2 1588bd35 484ea444
36343ff9 5ead6ab1 d8afb1b2 a303df1b 71e53c4a ea6b2e3e 9372be0d 1bc99798
b0ce3cc1 0d2a596d 565dba82 f88ce4cf f3b33d5d 24e9c083 1124bf1a d54b7925
32983dd6 c3a8b7d0

CMAC(K, M):

K = b3120ffd b2cf6af4 e73eaf2e f4ebec69

Mlen = 16512

M = 296f393c 5c000000 00000000 00000000 01010101 01010101 e0958045 f3a0bba4
e3968346 f0a3b8a7 c02a018a e6407652 26b987c9 13e6cbf0 83570016 cf83efbc
61c08251 3e21561a 427c009d 28c298ef ace78ed6 d56c2d45 05ad032e 9c04dc60
e73a8169 6da665c6 c48603a5 7b45ab33 221585e6 8ee31691 87fb0239 528632dd
656c807e a3248b7b 46d002b2 b5c7458e b85b9ce9 5879e034 0859055e 3b0abb3
eace8719 caa80265 c97205d5 dc4bcc90 2fe18396 29ed7132 8a0f0449 f588557e
6898860e 042aec8d 4b2404c2 12c9222d a5bf8a89 ef679787 0cf50771 a60f66a2
ee628536 57addf04 cdde07fa 414e11f1 2b4d81b9 b4e8ac53 8ea30666 688d881f
6c348421 992f31b9 4f8806ed 8fccff4c 9123b896 42527ad6 13b109bf 75167485
f1268bf8 84b4cd23 d29a0934 925703d6 34098f77 67f1be74 91e708a8 bb949a38
73708aef 4a36239e 50cc0823 5cd5ed6b be578668 a17b58c1 171d0b90 e813a9e4
f58a89d7 19b11042 d6360b1b 0f52deb7 30a58d58 faf46315 954b0a87 26914759

77dc88c0 d733feff 54600a0c c1d0300a aueb9457 2c6e95b0 1ae90de0 4f1dce47
f87e8fa7 bebf77e1 dbc20d6b a85cb914 3d518b28 5dfa04b6 98bf0cf7 819f20fa
7a288eb0 703d995c 59940c7c 66de57a9 b70f8237 9b70e203 1e450fcf d2181326
fcd28d88 23baaa80 df6e0f44 35596475 39fd8907 c0ffd9d7 9c130ed8 1c9afd9b
7e848c9f ed38443d 5d380e53 fdbb8ac8 c3d3f068 76054f12 2461107d e92fea09
c6f6923a 188d53af e54a10f6 0e6e9d5a 03d996b5 fbc820f8 a637116a 27ad04b4
44a0932d d60fbd12 671c11e1 c0ec73e7 89879faa 3d42c64d 20cd1252 742a3768
c25a9015 85888ece e1e612d9 936b403b 0775949a 66cdfd99 a29b1345 baa8d9d5
400c9102 4b0a6073 63b013ce 5de9ae86 9d3b8d95 b0570b3c 2d391422 d32450cb
cfae9665 2286e96d ec1214a9 34652798 0a8192ea c1c39a3a af6f1535 1da6be76
4df89772 ec0407d0 6e4415be fae7c925 80df9bf5 07497c8f 2995160d 4e218daa
cb02944a bf83340c e8be1686 a960faf9 0e2d90c5 5cc6475b abc3171a 80a36317
4954955d 7101dab1 6ae81791 67e21444 b443a9ea aa7c91de 36d118c3 9d389f8d
d4469a84 6c9a262b f7fa1848 7a79e8de 11699e0b 8fdf557c b48719d4 53ba7130
56109b93 a218c896 75ac195f b4fb0663 9b379714 4955b3c9 327d1aec 003d42ec
d0ea98ab f19ffb4a f3561a67 e77c35bf 15c59c24 12da881d b02b1bfb cebfac51
52bc99bc 3f1d15f7 71001b70 29fedb02 8f8b852b c4407eb8 3f891c9c a733254f
dd1e9edb 56919ce9 fea21c17 4072521c 18319a54 b5d4efbe bddf1d8b 69b1cbf2
5f489fcc 98137254 7cf41d00 8ef0bca1 926f934b 735e090b 3b251eb3 3a36f82e
d9b29cf4 cb944188 fa0e1e38 dd778f7d 1c9d987b 28d132df b9731fa4 f4b41693
5be49de3 0516af35 78581f2f 13f561c0 66336194 1eab249a 4bc123f8 d15cd711
a956a1bf 20fe6eb7 8aea2373 361da042 6c79a530 c3bb1de0 c99722ef 1fde39ac
2b00a0a8 ee7c800a 08bc2264 f89f4eff e627ac2f 0531fb55 4f6d21d7 4c590a70
adfaa390 bdfbb3d6 8e46215c ab187d23 68d5a71f 5ebec081 cd3b20c0 82dbe4cd
2faca287 73795d6b 0c10204b 659a939e f29bbe10 88243624 429927a7 eb576dd3
a00ea5e0 1af5d475 83b2272c 0c161a80 6521a16f f9b0a722 c0cf26b0 25d5836e
2258a4f7 d4773ac8 01e4263b c294f43d ef7fa870 3f3a4197 46352588 7652b0b2
a4a2a7cf 87f00914 871e2503 9113c7e1 618da340 64b57a43 c463249f b8d05e0f
26f4a6d8 4972e7a9 05482414 5f91295c dbec39a6f 920facc6 59712b46 a54ba295
bbe6a901 54e91b33 985a2bcd 420ad5c6 7ec9ad8e b7ac6864 db272a51 6bc94c28
39b0a816 9a6bf58e 1a0c2ada 8c883b7b f497a491 71268ed1 5ddd2969 384e7ff4
bf4aab2e c9ecc652 9cf629e2 df0f08a7 7a65afa1 2aa9b505 df8b287e f6cc9149
3d1caa39 076e28ef 1ea028f5 118de61a e02bb6ae fc3343a0 50292f19 9f401857
b2bead5e 6ee2a1f1 91022f92 78016f04 7791a9d1 8da7d2a6 d27f2e0e 51c2f6ea
30e8ac49 a0604f4c 13542e85 b68381b9 fdcfa0ce 4b2d3413 54852d36 0245c536

b612af71 f3e77c90 95ae2dbd e504b265 733dabfe 10a20fc7 d6d32c21 ccc72b8b
 3444ae66 3d65922d 17f82caa 2b865cd8 8913d291 a6589902 6ea13284 39723c19
 8c36b0c3 c8d085bf af8a320f de334b4a 4919b44c 2b95f6e8 ecf73393 f7f0d2a4
 0e60b1d4 06526b02 2ddc3318 10b1a5f7 c347bd53 ed1f105d 6a0d30ab a477e178
 889ab2ec 55d558de ab263020 4336962b 4db5b663 b6902b89 e85b31bc 6af50fc5
 0accb3fb 9b57b663 29703137 8db47896 d7fbaf6c 600add2c 67f936db 037986db
 856eb49c f2db3f7d a6d23650 e438f188 4041b013 119e4c2a e5af37cc cdfb6866
 0738b58b 3c59d1c0 24843747 2aba1f35 ca1fb90c d714aa9f 635534f4 9e7c5bba
 81c2b6b3 6fdee21c a27e347f 793d2ce9 44edb23c 8c9b914b e10335e3 50feb507
 0394b7a4 a15c0ca1 20283568 b7bfc254 fe838b13 7a2147ce 7c113a3a 4d65499d
 9e86b87d bcc7f03b bd3a3ab1 aa243ece 5ba9bcf2 5f82836c fe473b2d 83e7a720
 1cd0b96a 72451e86 3f6c3ba6 64a6d073 d1f7b5ed 990865d9 78bd3815 d06094fc
 9a2aba52 21c22d5a b996389e 3721e3af 5f05bedd c2875e0d faeb3902 1ee27a41
 187cbb45 ef40c3e7 3bc03989 f9a30d12 c54ba7d2 141da8a8 75493e65 776ef35f
 97debc22 86cc4af9 b4623eee 902f840c 52f1b8ad 658939ae f71f3f72 b9ec1de2
 1588bd35 484ea444 36343ff9 5ead6ab1 d8afb1b2 a303df1b 71e53c4a ea6b2e3e
 9372be0d 1bc99798 b0ce3cc1 0d2a596d 565dba82 f88ce4cf f3b33d5d 24e9c083
 1124bf1a d54b7925 32983dd6 c3a8b7d0

Subkey Generation:

L = 2c645dcd 72114961 d8b9c864 7aac2c5b
 K1 = 58c8bb9a e42292c3 b17390c8 f55858b6
 K2 = b1917735 c8452587 62e72191 eab0b16c

MAC Generation:

n = 129
 Mn* = 1124bf1a d54b7925 32983dd6 c3a8b7d0
 Mn = 49ec0480 3169ebe6 83ebad1e 36f0ef66
 C0 = 00000000 00000000 00000000 00000000
 M1 = 296f393c 5c000000 00000000 00000000
 C1 = 2c174eee b856df54 a2e3ce41 116181e0
 M2 = 01010101 01010101 e0958045 f3a0bba4
 C2 = 7a923db9 b053f844 9e706b27 378aeae0
 M3 = e3968346 f0a3b8a7 c02a018a e6407652
 C3 = 59d30ebc 8eb2314c 74fe3a04 1a248463

M4 = 26b987c9 13e6cbf0 83570016 cf83efbc
C4 = 78db898b 6396784c 34f8edbd e7a747c5
M5 = 61c08251 3e21561a 427c009d 28c298ef
C5 = 7c29e481 44ac6afa 3aca8a4a 7208ce99
M6 = ace78ed6 d56c2d45 05ad032e 9c04dc60
C6 = 7220fde3 3a769298 c9406349 6ad867d3
M7 = e73a8169 6da665c6 c48603a5 7b45ab33
C7 = 46e63f6e c6529a3b 2a7aa97c 0e280443
M8 = 221585e6 8ee31691 87fb0239 528632dd
C8 = 79803306 ad490c46 3d971205 dc99a211
M9 = 656c807e a3248b7b 46d002b2 b5c7458e
C9 = 4d74cec4 f07795ab f6127db4 529dfb57
M10 = b85b9ce9 5879e034 0859055e 3b0abbc3
C10 = a6eb9d1e 93820f49 d9c5f9e1 760cb686
M11 = eace8719 caa80265 c97205d5 dc4bcc90
C11 = 8f95155b d32ad9a3 463e905d 7ba480ee
M12 = 2fe18396 29ed7132 8a0f0449 f588557e
C12 = 6f120bf0 e6f4c66f a5c67815 65133712
M13 = 6898860e 042aecd8 4b2404c2 12c9222d
C13 = db74500e 895db74a ef3b3b87 25087f2b
M14 = a5bf8a89 ef679787 0cf50771 a60f66a2
C14 = f5879d17 7c0ddf7d 5772993a c137aeab
M15 = ee628536 57addf04 cdde07fa 414e11f1
C15 = b18a88a1 bceb93e0 a4b7ae95 4479bbfe
M16 = 2b4d81b9 b4e8ac53 8ea30666 688d881f
C16 = 7d75c4a5 e87bff2f 07471eb4 46fcd73
M17 = 6c348421 992f31b9 4f8806ed 8fccff4c
C17 = b3456ccb e8f3e8d7 33568c84 f89d2145
M18 = 9123b896 42527ad6 13b109bf 75167485
C18 = b5363e85 edabc25d bd1a400d 5952742e
M19 = f1268bf8 84b4cd23 d29a0934 925703d6
C19 = 55abea1b 574ea033 45df9cd1 46f1c8e9
M20 = 34098f77 67f1be74 91e708a8 bb949a38
C20 = 8efc00fd 5d245efc de807875 cd46423d
M21 = 73708aef 4a36239e 50cc0823 5cd5ed6b

C21 = aa07abd7 b26d40b0 53945cfa 6aafab45
M22 = be578668 a17b58c1 171d0b90 e813a9e4
C22 = 4739c2bb 17ae5960 7ac250e2 c4c172fa
M23 = f58a89d7 19b11042 d6360b1b 0f52deb7
C23 = eda48d2b 146feccf 11c45d3b 2aac4c37
M24 = 30a58d58 faf46315 954b0a87 26914759
C24 = 4dbbb4e3 9e344d41 d05ca472 50186527
M25 = 77dc88c0 d733feff 54600a0c c1d0300a
C25 = ecda3d93 5776d708 42c9c5da 9a09dbe3
M26 = aueb9457 2c6e95b0 1ae90de0 4f1dce47
C26 = 58a010aa f0149da7 5dfe9049 4676b663
M27 = f87e8fa7 bebf77e1 dbc20d6b a85cb914
C27 = d611b8cb bb9fb2ac f82aa88b fd6aab42
M28 = 3d518b28 5dfa04b6 98bf0cf7 819f20fa
C28 = a23131a6 d7352c69 e9790a6b 26b0292a
M29 = 7a288eb0 703d995c 59940c7c 66de57a9
C29 = 9026e0dd c60dc7fe 3ff024e4 5c853be8
M30 = b70f8237 9b70e203 1e450fcf d2181326
C30 = af09e79e 54d8c2e1 85b08d12 d638d687
M31 = fcd28d88 23baaa80 df6e0f44 35596475
C31 = f7bc7632 8b116b03 f5d1fd78 3f4d866d
M32 = 39fd8907 c0ffd9d7 9c130ed8 1c9afd9b
C32 = 0c2a4710 a2362a1f 7967fd45 1a7d188d
M33 = 7e848c9f ed38443d 5d380e53 fbdb8ac8
C33 = df3fc64e ff5998be 926a71d8 7836cf38
M34 = c3d3f068 76054f12 2461107d e92fea09
C34 = 11133bc0 6cdef5b2 0ba5cf12 b293ea83
M35 = c6f6923a 188d53af e54a10f6 0e6e9d5a
C35 = fe95113c c42ac4c4 bd53dfcb 41d01f1a
M36 = 03d996b5 fbc820f8 a637116a 27ad04b4
C36 = fbd5a26b 824d7a62 bdcad592 0ef8d4c8
M37 = 44a0932d d60fbd12 671c11e1 c0ec73e7
C37 = e75a94c8 e5b631b8 6e0f1153 f88b87aa
M38 = 89879faa 3d42c64d 20cd1252 742a3768
C38 = 773a8452 8fb77154 baaa0445 d517de8f

M39 = c25a9015 85888ece e1e612d9 936b403b
C39 = b53b90f0 6dce6530 593171f8 42eb5ab7
M40 = 0775949a 66cdfd99 a29b1345 baa8d9d5
C40 = 2d211e99 76cad436 d37bb281 74fd9aaf
M41 = 400c9102 4b0a6073 63b013ce 5de9ae86
C41 = 71f3983e 65f0af4d 028c1308 6488de12
M42 = 9d3b8d95 b0570b3c 2d391422 d32450cb
C42 = 0d292597 f79f9c95 f213724a 55e54437
M43 = cfae9665 2286e96d ec1214a9 34652798
C43 = 9b3ba456 072cdaa2 5bc5dae7 ab5e5c36
M44 = 0a8192ea c1c39a3a af6f1535 1da6be76
C44 = 0a3b8e65 0bf406a9 267783f1 69979a3e
M45 = 4df89772 ec0407d0 6e4415be fae7c925
C45 = 6a6cb8da bfaca611 7b7f1996 b83d4c92
M46 = 80df9bf5 07497c8f 2995160d 4e218daa
C46 = 6ed66263 70b356c4 bea4e69b fa281190
M47 = cb02944a bf83340c e8be1686 a960faf9
C47 = 65cf4cda 156b2025 b5b43852 022b0211
M48 = 0e2d90c5 5cc6475b abc3171a 80a36317
C48 = 96cff0a9 6e209fd5 065c9f34 e0edc899
M49 = 4954955d 7101dab1 6ae81791 67e21444
C49 = 61158848 8fb6a12b a2a155bc fa279420
M50 = b443a9ea aa7c91de 36d118c3 9d389f8d
C50 = 79a1892a 63751231 f45163bb cb8a7729
M51 = d4469a84 6c9a262b f7fa1848 7a79e8de
C51 = 25c71838 32d36692 22379a7b a086716c
M52 = 11699e0b 8fdf557c b48719d4 53ba7130
C52 = 466dbaf4 10f27161 202bd3e2 ce7fc5f3
M53 = 56109b93 a218c896 75ac195f b4fb0663
C53 = adcb04f6 86696807 38756fa3 7a350ccc
M54 = 9b379714 4955b3c9 327d1aec 003d42ec
C54 = 802a2d59 0b3a457a f449ba39 f8bad584
M55 = d0ea98ab f19ffb4a f3561a67 e77c35bf
C55 = b6bbd86d 5e708389 d18413f9 ddd9a92a
M56 = 15c59c24 12da881d b02b1bfb cebfac51

C56 = ff010e37 0ad1420e df6a5276 81b9f685
M57 = 52bc99bc 3f1d15f7 71001b70 29fedb02
C57 = a7af152e b0c0dc25 d96c9792 672c098e
M58 = 8f8b852b c4407eb8 3f891c9c a733254f
C58 = 957bc801 eaabe60c 27193122 a94cccb8
M59 = dd1e9edb 56919ce9 fea21c17 4072521c
C59 = 3b6d3712 3ea45568 15a4c417 3f903fc3
M60 = 18319a54 b5d4efbe bddf1d8b 69b1cbf2
C60 = 656e7869 42ef502b f5838dc4 44a89253
M61 = 5f489fcc 98137254 7cf41d00 8ef0bca1
C61 = 934b5a02 5051d909 a9d84ab2 547853c6
M62 = 926f934b 735e090b 3b251eb3 3a36f82e
C62 = b667b4da 06f5670f c014bb27 09e6e18c
M63 = d9b29cf4 cb944188 fa0e1e38 dd778f7d
C63 = 88033db1 446aaa10 a348ddaa d7d80d16
M64 = 1c9d987b 28d132df b9731fa4 f4b41693
C64 = 52d29028 818fae29 dad8c1fb 124d173f
M65 = 5be49de3 0516af35 78581f2f 13f561c0
C65 = b6131b03 2cc9c6ae 96051b5d 68aa7659
M66 = 66336194 1eab249a 4bc123f8 d15cd711
C66 = 58fbdb68 61d57ded 89977624 977ce584
M67 = a956a1bf 20fe6eb7 8aea2373 361da042
C67 = b9929b5e 371a0fb6 357c864d 4ea36d30
M68 = 6c79a530 c3bb1de0 c99722ef 1fde39ac
C68 = 198a06eb 2c013cab eadb6627 d555e3a6
M69 = 2b00a0a8 ee7c800a 08bc2264 f89f4eff
C69 = d1f0a42a b3045545 8e69a513 14825bfc
M70 = e627ac2f 0531fb55 4f6d21d7 4c590a70
C70 = 6b8c1b1a 03286dde f4ecf569 66f264d0
M71 = adfaa390 bdfbb3d6 8e46215c ab187d23
C71 = 082fe1f5 61373b7b 048b92ed 3b36c1d5
M72 = 68d5a71f 5ebec081 cd3b20c0 82dbe4cd
C72 = cd304dc4 682e63df 49b7da3b 1e780f3a
M73 = 2faca287 73795d6b 0c10204b 659a939e
C73 = 596f4ba2 4a20bb10 a9fa3124 6a7488b9

M74 = f29bbe10 88243624 429927a7 eb576dd3
C74 = 776ca237 97bc8e6b bca6eafd 8409dfe3
M75 = a00ea5e0 1af5d475 83b2272c 0c161a80
C75 = 828637a1 8145e141 83f331c6 606b7d86
M76 = 6521a16f f9b0a722 c0cf26b0 25d5836e
C76 = d7791efa bc262f54 835ec67c 7a224aff
M77 = 2258a4f7 d4773ac8 01e4263b c294f43d
C77 = af53bb31 351481e9 7a71d208 f603161e
M78 = ef7fa870 3f3a4197 46352588 7652b0b2
C78 = d4022c6e 13ea8576 e2828b8a 71889135
M79 = a4a2a7cf 87f00914 871e2503 9113c7e1
C79 = 934e9389 7d051877 7e33d2b5 51d450ba
M80 = 618da340 64b57a43 c463249f b8d05e0f
C80 = 0d505c6e 3820f48f 2d9d7965 7fda8c62
M81 = 26f4a6d8 4972e7a9 05482414 5f91295c
C81 = 7e83e4a2 e028cb71 aa4d49c3 77cb6878
M82 = dbec39a6f 920facc6 59712b46 a54ba295
C82 = e60a012c 3604a26b fcbd8bb8 ada3fa25
M83 = bbe6a901 54e91b33 985a2bcd 420ad5c6
C83 = 3b571f1e 45fc0552 6ac062f6 e38133b9
M84 = 7ec9ad8e b7ac6864 db272a51 6bc94c28
C84 = 64c12b59 f3f996cf aa4600f0 bbe782c7
M85 = 39b0a816 9a6bf58e 1a0c2ada 8c883b7b
C85 = 6d697d70 41a532be 99db1d5e 1802416e
M86 = f497a491 71268ed1 5ddd2969 384e7ff4
C86 = e13200d9 02b60040 c8d432e3 c6476faf
M87 = bf4aab2e c9ecc652 9cf629e2 df0f08a7
C87 = bb96999a e4f1f5cb 9f6c2787 1215a092
M88 = 7a65afa1 2aa9b505 df8b287e f6cc9149
C88 = f2ede003 89c33765 4d195eeb ceda25e7
M89 = 3d1caa39 076e28ef 1ea028f5 118de61a
C89 = bfa3ef0f 3171e7fa 90b5b1b8 e1a002d6
M90 = e02bb6ae fc3343a0 50292f19 9f401857
C90 = 56e2b617 3161c6c2 1e122148 86ecd966
M91 = b2bead5e 6ee2a1f1 91022f92 78016f04

C91 = d3a15f8e 6390dafa fc41cab0 472a7670
M92 = 7791a9d1 8da7d2a6 d27f2e0e 51c2f6ea
C92 = 5b666f14 2c224401 655c48e8 d1b2c12e
M93 = 30e8ac49 a0604f4c 13542e85 b68381b9
C93 = 4413e8b8 94bee1f2 05e193ee b695ab3d
M94 = fdcfa0ce 4b2d3413 54852d36 0245c536
C94 = 7e0693cb ed077fa8 2944064c ffc7d5d6
M95 = b612af71 f3e77c90 95ae2dbd e504b265
C95 = d25164b5 d9efcd07 17be88f0 17990efd
M96 = 733dabfe 10a20fc7 d6d32c21 ccc72b8b
C96 = 9e2abf1e 5f8ebdf4 2fb41ae7 d4eb6973
M97 = 3444ae66 3d65922d 17f82caa 2b865cd8
C97 = d7fe8071 8577524b 01297cf3 ae68a829
M98 = 8913d291 a6589902 6ea13284 39723c19
C98 = 0c6be895 d9e858a7 e2500452 42e2686e
M99 = 8c36b0c3 c8d085bf af8a320f de334b4a
C99 = 3629aeb3 673b422d 4aea4a5c 5a935941
M100 = 4919b44c 2b95f6e8 ecf73393 f7f0d2a4
C100 = 6cc0142b e8455f69 67284dc0 dd708f02
M101 = 0e60b1d4 06526b02 2ddc3318 10b1a5f7
C101 = d2839043 25718658 fac2fb23 59d3994f
M102 = c347bd53 ed1f105d 6a0d30ab a477e178
C102 = a5b5a2bf 19ec33b3 d2296d4a 3735981e
M103 = 889ab2ec 55d558de ab263020 4336962b
C103 = e97eb2ee e9769c3d ea6ad1bb ea079a88
M104 = 4db5b663 b6902b89 e85b31bc 6af50fc5
C104 = 042f1f1c 59a41204 1484dd2b 426eb392
M105 = 0accb3fb 9b57b663 29703137 8db47896
C105 = 45e15f74 bb550567 a80a5dac acc18ebb
M106 = d7fbaf6c 600add2c 67f936db 037986db
C106 = 9e285b68 8a3338f8 dc2e12de d3a89153
M107 = 856eb49c f2db3f7d a6d23650 e438f188
C107 = 48f6e6c3 0b1448b7 a94983d3 1416029d
M108 = 4041b013 119e4c2a e5af37cc cdfb6866
C108 = a4645c35 b9a4f509 89704523 0e98fac1

M109 = 0738b58b 3c59d1c0 24843747 2aba1f35
C109 = f8ec48ec 33ad7364 20ea077f 16be98b8
M110 = ca1fb90c d714aa9f 635534f4 9e7c5bba
C110 = 8de31e96 1bb879e2 ca169749 51afab6f
M111 = 81c2b6b3 6fdee21c a27e347f 793d2ce9
C111 = f602eab6 e1373191 fc30b633 8cd82741
M112 = 44edb23c 8c9b914b e10335e3 50feb507
C112 = 762c51e6 d30a4eab 869c8827 0d698121
M113 = 0394b7a4 a15c0ca1 20283568 b7bfc254
C113 = e1db681b 5fb862fc b1c3747f ab057c1c
M114 = fe838b13 7a2147ce 7c113a3a 4d65499d
C114 = e77d4ba4 812e0730 4eb1ee0e c233685d
M115 = 9e86b87d bcc7f03b bd3a3ab1 aa243ece
C115 = 177fd714 1f206a6f 06940efd a023309f
M116 = 5ba9bcf2 5f82836c fe473b2d 83e7a720
C116 = c738f59b 0715dded 2efe635d a073b5a3
M117 = 1cd0b96a 72451e86 3f6c3ba6 64a6d073
C117 = c99dbfa3 ebd3f018 bba8b961 96818130
M118 = d1f7b5ed 990865d9 78bd3815 d06094fc
C118 = eebd79e4 c7378d33 3941a3c5 45ee8d37
M119 = 9a2aba52 21c22d5a b996389e 3721e3af
C119 = dbdce382 e9abef5d 39f309ad a6ce7e8c
M120 = 5f05bedd c2875e0d faeb3902 1ee27a41
C120 = 7f851259 1a77d8a5 2f146735 6ebec181
M121 = 187cbb45 ef40c3e7 3bc03989 f9a30d12
C121 = 8e423a41 34eca7b9 f8a1c48e 6fbc50ec
M122 = c54ba7d2 141da8a8 75493e65 776ef35f
C122 = b6e40968 80bfc03f c7aa655b c0e12a25
M123 = 97debc22 86cc4af9 b4623eee 902f840c
C123 = 3a1a64aa b9addbd6 eb3ad3b1 1f2fe168
M124 = 52f1b8ad 658939ae f71f3f72 b9ec1de2
C124 = 1559a703 6187d461 52dbf04d 4bac3ca0
M125 = 1588bd35 484ea444 36343ff9 5ead6ab1
C125 = 16136377 e935b0fd e2c2ab4e 1718b30e
M126 = d8afb1b2 a303df1b 71e53c4a ea6b2e3e

C126 = 995211d4 8695b1a2 a59b377d d2829f31
 M127 = 9372be0d 1bc99798 b0ce3cc1 0d2a596d
 C127 = e8c5844a c73c27d1 3b0b6df9 3142fdaa
 M128 = 565dba82 f88ce4cf f3b33d5d 24e9c083
 C128 = 64c755f6 43c48ee6 1e5af291 ea4df86f
 M129 = 49ec0480 3169ebe6 83ebad1e 36f0ef66
 C129 = ebd5ccb0 b61ca905 29138303 f3377d22

MACT = ebd5ccb0

C.3 128-EEA1

No new test data are provided for 128-EEA1, because the test data for UEA2 can be reused directly – there is an exact, one-to-one mapping between UEA2 inputs and 128-EEA1 inputs.

C.4 128-EIA1

This section includes seven test data sets; all are presented in hex, while the first is also presented in binary

Bit ordering should be largely self explanatory, but in particular:

- The 5-bit BEARER is written in hex in a "right aligned" form, i.e. as a two-hex-digit value in the range 00 to 1F inclusive, with BEARER [0] as the msb of the first digit.
- Similarly the single DIRECTION bit is written in hex in "right aligned" form, i.e. the DIRECTION bit is the lsb of the hex digit.
- Where the length of the message, or of a message sub-block, is not a multiple of 32 bits, it is written in hex in a "left aligned" form, i.e. the least significant few bits of the last word will be zero.

NOTE: This section provides both byte aligned and non byte aligned test data sets. For EPS implementation verification, byte alignment test data sets (1, 4 and 7) can be used, as EPS RRC and EPS NAS messages are byte aligned. The non byte aligned test data sets may be used to verify implementations that support non byte aligned messages.

C.4.1 Test Set 1

Count-I = (hex) 38a6f056

Count-I = (bin) 00111000 10100110 11110000 01010110

Bearer = (hex) 1f

Bearer = (bin) 11111

Direction = (hex) 0

Direction = (bin) 0

IK = (hex) 2bd6459f 82c5b300 952c4910 4881ff48

IK = (bin) 00101011 11010110 01000101 10011111 10000010 11000101 10110011 00000000

10010101 00101100 01001001 00010000 01001000 10000001 11111111 01001000

Length = 88 bits

Message = (hex) 33323462 63393861 37347900 00000000

Message = (bin) 00110011 00110010 00110100 01100010 01100011 00111001 00111000 01100001
00110111 00110100 01111001

MACT = (hex) 731f1165

MACT = (bin) 01110011 00011111 00010001 01100101

C.4.2 Test Set 2

Count-I = 36af6144

Bearer = 18

Direction = 1

IK = 7e5e9443 1e11d738 28d739cc 6ced4573

Length = 254 bits

Message = b3d3c917 0a4e1632 f60f8610 13d22d84 b726b6a2 78d802d1 eef1321 ba5929dc

MACT = e3259f6f

C.4.3 Test Set 3

Count-I = c7590ea9

Bearer = 17

Direction = 0

IK = d3419be8 21087acd 02123a92 48033359

Length = 511 bits

Message = bbb05703 8809496b cff86d6f bc8ce5b1 35a06b16 6054f2d5 65be8ace 75dc851e
0bcdd8f0 7141c495 872fb5d8 c0c66a8b 6da55666 3e4e4612 05d84580 bee5bc7e

MACT = 9a16c77d

C.4.4 Test Set 4

Count-I = 36af6144

Bearer = 0f

Direction = 1

IK = 83fd23a2 44a74cf3 58da3019 f1722635

Length = 768 bits

Message = 35c68716 633c66fb 750c2668 65d53c11 ea05b1e9 fa49c839 8d48e1ef a5909d39
47902837 f5ae96d5 a05bc8d6 1ca8dbef 1b13a4b4 abfe4fb1 006045b6 74bb5472
9304c382 be53a5af 05556176 f6eaa2ef 1d05e4b0 83181ee6 74cda5a4 85f74d7a

MACT = bba74492

C.4.5 Test Set 5

Count-I = 36af6144

Bearer = 18

Direction = 0

IK = 6832a65c ff447362 1ebdd4ba 26a921fe

Length = 383 bits

Message = d3c53839 62682071 77656676 20323837 63624098 1ba6824c 1bfb1ab4 85472029
b71d808c e33e2cc3 c0b5fc1f 3de8a6dc

MACT = 4145e4b0

C.4.6 Test Set 6

Count-I = 7827fab2

Bearer = 05

Direction = 1

IK = 5d0a80d8 134ae196 77824b67 1e838af4

Length = 2558 bits

Message = 70dedf2d c42c5cbd 3a96f8a0 b11418b3 608d5733 604a2cd3 6aabc70c e3193bb5
153be2d3 c06dfdb2 d16e9c35 7158be6a 41d6b861 e491db3f bfeb518e fcf048d7
d5895373 0ff30c9e c470ffcd 663dc342 01c36add c0111c35 b38afee7 cfdb582e
3731f8b4 baa8d1a8 9c06e811 99a97162 27be344e fcb436dd d0f096c0 64c3b5e2
c399993f c77394f9 e09720a8 11850ef2 3b2ee05d 9e617360 9d86e1c0 c18ea51a
012a00bb 413b9cb8 188a703c d6bae31c c67b34b1 b00019e6 a2b2a690 f02671fe
7c9ef8de c0094e53 3763478d 58d2c5f5 b827a014 8c5948a9 6931acf8 4f465a64
e62ce740 07e991e3 7ea823fa 0fb21923 b79905b7 33b631e6 c7d6860a 3831ac35
1a9c730c 52ff72d9 d308eedb ab21fde1 43a0ea17 e23edc1f 74cbb363 8a2033aa
a15464ea a733385d bbeb6fd7 3509b857 e6a419dc a1d8907a f977fbac 4dfa35ec

MACT = 0fa2b1ee

C.4.7 Test Set 7

Count-I = 296f393c

Bearer = 0b

Direction = 1

IK = b3120ffd b2cf6af4 e73eaf2e f4ebec69

Length = 16448 bits

Message = 00000000 00000000 01010101 01010101 e0958045 f3a0bba4 e3968346 f0a3b8a7

c02a018a e6407652 26b987c9 13e6cbf0 83570016 cf83efbc 61c08251 3e21561a
427c009d 28c298ef ace78ed6 d56c2d45 05ad032e 9c04dc60 e73a8169 6da665c6
c48603a5 7b45ab33 221585e6 8ee31691 87fb0239 528632dd 656c807e a3248b7b
46d002b2 b5c7458e b85b9ce9 5879e034 0859055e 3b0abbc3 eace8719 caa80265
c97205d5 dc4bcc90 2fe18396 29ed7132 8a0f0449 f588557e 6898860e 042aecd8
4b2404c2 12c9222d a5bf8a89 ef679787 0cf50771 a60f66a2 ee628536 57addf04
cdde07fa 414e11f1 2b4d81b9 b4e8ac53 8ea30666 688d881f 6c348421 992f31b9
4f8806ed 8fccff4c 9123b896 42527ad6 13b109bf 75167485 f1268bf8 84b4cd23
d29a0934 925703d6 34098f77 67f1be74 91e708a8 bb949a38 73708aef 4a36239e
50cc0823 5cd5ed6b be578668 a17b58c1 171d0b90 e813a9e4 f58a89d7 19b11042
d6360b1b 0f52deb7 30a58d58 faf46315 954b0a87 26914759 77dc88c0 d733feff
54600a0c c1d0300a aae9457 2c6e95b0 1ae90de0 4f1dce47 f87e8fa7 bebf77e1
dbc20d6b a85cb914 3d518b28 5dfa04b6 98bf0cf7 819f20fa 7a288eb0 703d995c
59940c7c 66de57a9 b70f8237 9b70e203 1e450fcf d2181326 fcd28d88 23baaa80
df6e0f44 35596475 39fd8907 c0ffd9d7 9c130ed8 1c9afd9b 7e848c9f ed38443d
5d380e53 fbdb8ac8 c3d3f068 76054f12 2461107d e92fea09 c6f6923a 188d53af
e54a10f6 0e6e9d5a 03d996b5 fbc820f8 a637116a 27ad04b4 44a0932d d60fbd12
671c11e1 c0ec73e7 89879faa 3d42c64d 20cd1252 742a3768 c25a9015 85888ece
e1e612d9 936b403b 0775949a 66cdfd99 a29b1345 baa8d9d5 400c9102 4b0a6073
63b013ce 5de9ae86 9d3b8d95 b0570b3c 2d391422 d32450cb cfae9665 2286e96d
ec1214a9 34652798 0a8192ea c1c39a3a af6f1535 1da6be76 4df89772 ec0407d0
6e4415be fae7c925 80df9bf5 07497c8f 2995160d 4e218daa cb02944a bf83340c
e8be1686 a960faf9 0e2d90c5 5cc6475b abc3171a 80a36317 4954955d 7101dab1
6ae81791 67e21444 b443a9ea aa7c91de 36d118c3 9d389f8d d4469a84 6c9a262b
f7fa1848 7a79e8de 11699e0b 8fdf557c b48719d4 53ba7130 56109b93 a218c896
75ac195f b4fb0663 9b379714 4955b3c9 327d1aec 003d42ec d0ea98ab f19ffb4a
f3561a67 e77c35bf 15c59c24 12da881d b02b1bfb cebfac51 52bc99bc 3f1d15f7
71001b70 29fedb02 8f8b852b c4407eb8 3f891c9c a733254f dd1e9edb 56919ce9
fea21c17 4072521c 18319a54 b5d4efbe bddf1d8b 69b1cbf2 5f489fcc 98137254
7cf41d00 8ef0bca1 926f934b 735e090b 3b251eb3 3a36f82e d9b29cf4 cb944188
fa0e1e38 dd778f7d 1c9d987b 28d132df b9731fa4 f4b41693 5be49de3 0516af35
78581f2f 13f561c0 66336194 1eab249a 4bc123f8 d15cd711 a956a1bf 20fe6eb7
8aea2373 361da042 6c79a530 c3bb1de0 c99722ef 1fde39ac 2b00a0a8 ee7c800a

08bc2264 f89f4eff e627ac2f 0531fb55 4f6d21d7 4c590a70 adfaa390 bdfbb3d6
8e46215c ab187d23 68d5a71f 5ebec081 cd3b20c0 82dbe4cd 2faca287 73795d6b
0c10204b 659a939e f29bbe10 88243624 429927a7 eb576dd3 a00ea5e0 1af5d475
83b2272c 0c161a80 6521a16f f9b0a722 c0cf26b0 25d5836e 2258a4f7 d4773ac8
01e4263b c294f43d ef7fa870 3f3a4197 46352588 7652b0b2 a4a2a7cf 87f00914
871e2503 9113c7e1 618da340 64b57a43 c463249f b8d05e0f 26f4a6d8 4972e7a9
05482414 5f91295c dbc39a6f 920facc6 59712b46 a54ba295 bbe6a901 54e91b33
985a2bcd 420ad5c6 7ec9ad8e b7ac6864 db272a51 6bc94c28 39b0a816 9a6bf58e
1a0c2ada 8c883b7b f497a491 71268ed1 5ddd2969 384e7ff4 bf4aab2e c9ecc652
9cf629e2 df0f08a7 7a65afa1 2aa9b505 df8b287e f6cc9149 3d1caa39 076e28ef
1ea028f5 118de61a e02bb6ae fc3343a0 50292f19 9f401857 b2bead5e 6ee2a1f1
91022f92 78016f04 7791a9d1 8da7d2a6 d27f2e0e 51c2f6ea 30e8ac49 a0604f4c
13542e85 b68381b9 fdcfa0ce 4b2d3413 54852d36 0245c536 b612af71 f3e77c90
95ae2dbd e504b265 733dabfe 10a20fc7 d6d32c21 ccc72b8b 3444ae66 3d65922d
17f82caa 2b865cd8 8913d291 a6589902 6ea13284 39723c19 8c36b0c3 c8d085bf
af8a320f de334b4a 4919b44c 2b95f6e8 ecf73393 f7f0d2a4 0e60b1d4 06526b02
2ddc3318 10b1a5f7 c347bd53 ed1f105d 6a0d30ab a477e178 889ab2ec 55d558de
ab263020 4336962b 4db5b663 b6902b89 e85b31bc 6af50fc5 0accb3fb 9b57b663
29703137 8db47896 d7fbaf6c 600add2c 67f936db 037986db 856eb49c f2db3f7d
a6d23650 e438f188 4041b013 119e4c2a e5af37cc cdfb6866 0738b58b 3c59d1c0
24843747 2aba1f35 ca1fb90c d714aa9f 635534f4 9e7c5bba 81c2b6b3 6fdee21c
a27e347f 793d2ce9 44edb23c 8c9b914b e10335e3 50feb507 0394b7a4 a15c0ca1
20283568 b7bfc254 fe838b13 7a2147ce 7c113a3a 4d65499d 9e86b87d bcc7f03b
bd3a3ab1 aa243ece 5ba9bcf2 5f82836c fe473b2d 83e7a720 1cd0b96a 72451e86
3f6c3ba6 64a6d073 d1f7b5ed 990865d9 78bd3815 d06094fc 9a2aba52 21c22d5a
b996389e 3721e3af 5f05bedd c2875e0d faeb3902 1ee27a41 187cbb45 ef40c3e7
3bc03989 f9a30d12 c54ba7d2 141da8a8 75493e65 776ef35f 97debc22 86cc4af9
b4623eee 902f840c 52f1b8ad 658939ae f71f3f72 b9ec1de2 1588bd35 484ea444
36343ff9 5ead6ab1 d8afb1b2 a303df1b 71e53c4a ea6b2e3e 9372be0d 1bc99798
b0ce3cc1 0d2a596d 565dba82 f88ce4cf f3b33d5d 24e9c083 1124bf1a d54b7925
32983dd6 c3a8b7d0

MACT = abf3e651

Annex D (normative): Security for Relay Node Architectures

D.1 Introduction

This Annex provides the security procedures applied to relay nodes. Security requirements and security features applied to relay nodes can be found in the main body of the present specification.

The overall stage 2 description for relay nodes can be found in 3GPP TS 23.401 [2] and 3GPP TS 36.300 [30].

D.2 Solution

D.2.1 General

The basic idea of the solution for relay node security presented in this Annex is realizing a one-to-one binding of an RN and a USIM called USIM-RN. Such a one-to-one binding is realized in this solution either by using symmetric pre-shared keys (psk) or by certificates. In the psk case, the binding needs to be pre-established in the UICC and in the RN prior to deployment; in the certificate case, the binding needs to be pre-established only in the UICC prior to deployment. The use of certificates has the advantage that there is a standardized procedure for enrolling the private key corresponding to the certificate in the secure environment of the RN while the use of a psk requires manual operation for establishing the psk. A further advantage is that the name (identity) in the certificate can be given at time of enrolment, and does not have to be pre-established. On the other hand, the use of a psk has the advantage that no PKI is required and the procedure after pre-establishment of the psk is simpler. When using certificates for this one-to-one binding, a part of the usual certificate handling is replaced by subscription handling, as explained in Annex D.2.6.

The certificate-based procedures are mandatory to support.

The pre-shared-key-based procedures are mandatory to support.

NOTE 1: The provisioning of pre-shared keys is out of the scope of this document.

When using certificates the UICC inserted in the RN shall contain two USIMs: a USIM-RN which shall perform any communication only via a secure channel, and a USIM-INI communicating with the RN without secure channel and used for initial IP connectivity purposes prior to RN attachment. The UICC shall establish a secure channel only with a particular relay node, as detailed in the procedures described in D.2.2. The UICC verifies this relay node by means of data pre-established in the UICC.

When using psk only the USIM-RN is required. This USIM-RN shall perform any communication only via a secure channel.

NOTE 2: USIM-INI and USIM-RN are described in TS 31.102 [3].

D.2.2 Security Procedures

The start-up of an RN shall proceed in the following steps, which are arranged in three phases. The Preparation Phase and Phase II procedures are the same for the certificate-based and the PSK-based case. Phase I procedures differ between the certificate-based case and the pre-shared key based case. If one of the steps fails in any of the involved entities the procedure shall be aborted by that entity, and the steps that follow the failed step shall not be executed (but the sending of failure messages is possible).

Preparation Phase:

The RN platform secure environment shall perform an integrity check of the RN platform. This shall include checking the integrity of the sensitive parts of the boot process and proceeding with the boot process only if the integrity checks of all these parts are successful.

Phase I: Procedures prior to the RN attach procedure (certificate-based case)

For the certificate-based case, the RN may skip Phase I attachment if the RN has an operator certificate available and a valid CRL list (if needed).

NOTE0: There may be reasons to perform Phase I attachment even if operator certificate and valid CRL are available.

Ec1. Void.

Ec2. The RN shall attach as a UE using USIM-INI if step Ec3 needs to be performed.

Ec3. The RN shall obtain an operator certificate through the enrolment procedure defined in TS 33.310 [6] unless an operator certificate is already available. Details can be found in clause D.2.4. The RN may optionally establish a secure connection to an OAM server. Details can be found in clause D.2.5. The RN shall retrieve a CRL from a suitable server if no valid CRL is available locally in the RN and the RN supports and is configured to perform CRL checks. For revocation checking of UICC certificates see clause D.2.6. For the handling of CRLs for UICC certificates see also clause D.3.3.4.

Ec4. After completing step Ec3, the RN shall detach from the network and de-activate the USIM-INI if it attached in step Ec2. If the UICC needs to be configured over the air (OTA) this may also be done in this step.

Ec5. The RN platform secure environment and the UICC shall establish a Secure Channel between RN and USIM-RN according to ETSI TS 102 484 [29] clause 7 "Secured APDU" with TLS handshake. This TLS handshake shall be initiated by the RN and use certificates on both sides. The RN shall either use a pre-established certificate or the certificate enrolled in step Ec3. The UICC shall verify that this certificate belongs to the relay node the USIM-RN is bound to. The UICC shall be pre-provisioned with an operator root certificate to verify the RN certificate. The UICC certificate shall be pre-installed in the UICC by the operator. The RN shall be provisioned with a root certificate to verify the UICC certificate.

Ec6. A certificate validation client on the UICC shall verify the signatures in the RN certificate chain up to the root certificate. The check of revocation status and expiry time shall be omitted. A certificate validation client on the RN shall check the verification of the signatures in the UICC certificate chain up to the root certificate as well as the expiry time. The revocation status of the UICC certificate should be checked by means of CRLs. Furthermore, the requirements in clause D.2.3 on 'USIM Binding Aspects' shall apply.

NOTE 1: The root certificate, and potentially other data required, that need to be stored in the UICC could be provisioned in the UICC during its personalization. The operator provides to smart card manufacturer a list of data (e.g. IMSI, key K, etc) to be provisioned in the UICC during its personalization phase, before issuance of the UICC. The root certificate, and potentially other data, could be provided by the operator as part of the data to be personalized in the UICC by the smart card manufacturer. In the field, the root certificate, and potentially other data, could also be updated by OTA means, if needed.

The private key corresponding to the RN certificate and the root certificate used to verify the UICC certificate shall be stored in the secure environment of the RN platform validated in the Preparation Phase, and the TLS connection as well as the secure channel with the UICC shall terminate there. From the completion of this step onwards, all communication between the USIM-RN and the RN shall be protected by the Secure Channel.

The USIM-RN shall not engage in any communication with any entity prior to the the completion of establishment of the Secure Channel according to steps Ec5 and Ec6 other than messages for establishing the Secure Channel according to ETSI TS 102 484 [29] clause 7 "Secured APDU".

NOTE 2: Certificate use restriction may be made possible e.g. through a suitable name structure, or a particular intermediate CA in the verification path, or policy information terms, e.g. by a suitable object identifier (OID) in the certificate policies extension.

NOTE 3: ETSI TS 102 484 [29] states in clause 6.2.2: "The UICC may present a self-signed certificate. The terminal or terminal application should temporarily accept such a certificate during the TLS handshake protocol, if it is able to establish by other means (e.g. successful network authentication) that the handshake protocol is conducted with an authentic UICC." Similar considerations apply when the method in ETSI TS 102 484 [29] in clause 7 "Secured APDU" with TLS handshake is used as is the case in the present document. And in the present solution for relay node security, the RN indeed verifies the authenticity of the USIM-RN by means of a successful RN attach procedure. However, the use of a self-signed UICC certificate, or no UICC certificate at all, is not allowed here as this would weaken the protection against certain attacks, cf. clause D.2.6.

NOTE 4: It is proposed here that the RN assumes the role of TLS client in line with ETSI TS 102 484 [29], clause 7, on "Secured APDU" with TLS handshake.

NOTE 5: One may want to limit the lifetime of a secure channel between USIM-RN and RN for security reasons. Suitable counters providing such a limit include a transaction counter, cf. clause 5 of ETSI TS 102 484 [29]. Details can be found in stage 3 specifications.

NOTE 6: Having two USIMs on one UICC is a standard feature available today (but only one USIM can be active at a time in current 3GPP specifications).

NOTE 7: The RN could distinguish a USIM-RN from a USIM-UNI e.g. by the use of so-called "Application Identifiers (AID)" for UICC applications.

Phase I: Procedures prior to the RN attach procedure (pre-shared key based case)

For the psk-based case, there may be some cases when skipping of Phase I attachment is possible. Such cases are outside the scope of the present document.

Ep1. Void.

Ep2. The RN platform secure environment and the UICC shall establish a Secure Channel between RN and USIM-RN according to ETSI TS 102 484 [29] clause 7 "Secured APDU" using a pre-shared key. Furthermore, the requirements in clause D.2.3 on 'USIM Binding Aspects' shall apply.

The pre-shared key shall be stored in the secure environment of the RN platform validated in the Preparation Phase, and the secure channel with the UICC shall terminate there. From the completion of this step onwards, all communication between the USIM-RN and the RN shall be protected by the Secure Channel.

The USIM-RN shall not engage in any communication with any entity prior to the completion of the establishment of the Secure Channel according to step Ep2 other than messages for establishing the Secure Channel according to ETSI TS 102 484 [29] clause 7 "Secured APDU".

Ep3. The RN may optionally establish a secure connection to an OAM server. Details can be found in clause D.2.5.

Ep4. The RN shall detach from to the network if it attached for performing step Ep3.

NOTE 8: The use of the pre-shared key variant requires that the RN is configured with this pre-shared key e.g. in the factory, or at the operator's premises or in the field during RN installation. The corresponding procedures are out of scope of the present document. For the UICC, the regular personalization procedures are expected to apply.

NOTE 9: One may want to limit the lifetime of a secure channel between USIM-RN and RN for security reasons. Suitable counters providing such a limit include a record counter, cf. clause 6.4 of ETSI TS 102 484 [29], or a transaction counter, cf. clause 5 of ETSI TS 102 484 [29]. Details can be found in stage 3 specifications.

Phase II: RN attach procedure (pre-shared key case and certificate-based case)

It is required that a secure channel between RN and USIM-RN exists throughout the execution of phase II.

The RN shall perform the RN attach procedure for EPS as defined in TS 36.300 [30], using the USIM-RN. In addition, the following security-related steps shall be performed:

A1. If the USIM-RN is not already active the RN shall activate it and shall establish a new secure channel according to Ec5, Ec6 in the certificate-based case and Ep2 in the pre-shared key based case respectively. The RN shall use the IMSI (or a related GUTI) pertaining to the USIM-RN in the RN attach procedure.

NOTE 10: In the certificate-based case this IMSI differs from the one pertaining to the USIM-INI, therefore the network can distinguish the handling of the two USIMs.

A2. The S1 Initial UE message shall indicate that the attachment is for an RN. Upon receipt of this message the MME-RN shall run EPS AKA with the RN and the USIM-RN. The RN shall accept only authentication responses and keys in an RN attach procedure that were received from the USIM-RN over the Secure Channel.

A3. The MME-RN shall check from the RN-specific subscription data received from the HSS that the USIM-RN is permitted for use in RN attach procedures. When this is not the case, but the S1 Initial UE message indicated that the attachment is for an RN, the MME-RN shall reject the Attach request and indicate to the DeNB that the set-up has failed.

A4. The MME-RN and RN shall establish NAS security. Upon receipt of the S1 INITIAL CONTEXT SETUP message the DeNB and the RN shall set up AS security over Un as specified in the present document.

A5. The RN may establish a secure connection to an OAM server in this phase to complete the configuration. Details can be found in clause D.2.5.

The RN start-up is now complete from a security point of view, and UEs can start attaching to the RN.

D.2.3 USIM Binding Aspects

There shall be a one-to-one association between the USIM-RN and the RN.

In the pre-shared key case, this one-to-one association is ensured by the fact that the key that is pre-shared between the USIM-RN and the RN shall not be available in any other entity.

In the certificate-based case, this one-to-one association is ensured by the following requirements:

- The UICC shall verify the RN identity, represented by the RN identity in the certificate, through the TLS handshake as part of the secure channel set-up, and shall check whether it coincides with the locally stored identity of the RN authorized to set up a secure channel with the USIM-RN;
- the identity in an RN certificate shall be unique;
- a particular RN identity shall be available in only one UICC.

The procedures for managing the binding between USIM-RN and the RN are out of scope of the present document.

The UICC may know the identity of the RN authorized to set up a secure channel with the USIM-RN by configuration. The standard secure OTA mechanisms (TS 31.116 [31]) can be used to update the configuration of UICC and renew the stored identities if required.

NOTE: The RN identity is contained in the subject name of the RN certificate. It is described in detail in clause D.3.3 of the present document and in TS 31.102 [13].

D.2.4 Enrolment procedures for RNs

This subclause applies only to the certificate-based case.

The RN may enroll a device certificate as with macro eNBs according to TS 33.310 [6] prior to the RN attach procedure with the DeNB. This certificate may then be used for establishing the secure channel between RN and USIM-RN.

The certificate enrolment procedure does not rely on the security at the AS level, but is secured at the application layer. It can be therefore executed before security on the Un interface has been established. However, the RN requires IP connectivity for the enrolment procedure to be able to reach the Registration Authority RA.

The IP connectivity required for enrolment may be established in the following ways:

- (1) The RN may use offline means for enrolment purposes. No USIM is required.

- (2) The RN may attach to an eNB like a normal UE using a USIM, called USIM-INI, different from the one used in the RN attach procedure to the DeNB, called USIM-RN. No secure channel between RN and USIM-INI is required.

In both cases, the network shall ensure that the destinations the RN can reach are restricted to only the PDN(s) where the RA (Registration Authority for the certificate enrolment) and other servers to be contacted during phase I, e.g. the OAM server are located. In case (2) this shall be ensured by restricting IP traffic originating from the RN and sent only to certain destinations (APNs). The restrictions are assumed to be part of the profile relating to the subscription associated with the USIM-INI.

D.2.5 Secure management procedures for RNs

The requirements on communication between the OAM systems and the eNB from clause 5.3.2 shall apply for relay nodes in both phases I and II. The mechanisms used to fulfil these requirements shall include applying security association(s) that extend between the RN and an entity in the Evolved Packet Core (EPC) or in an OAM domain trusted by the operator.

NOTE 1: No mechanisms used to fulfil these requirements are mandated in the present document. But example mechanisms are given in NOTE 3 below. NOTE 3 is followed by normative text, which applies if the example mechanisms are used.

NOTE 2: In case of offline configuration of the RN, the security measures used to fulfil the requirements from clause 5.3.2 are out of scope of the present document.

NOTE 3: Examples for mechanisms to secure OAM communication to and from RNs are:

- *end-to-end security* terminated within or just in front of the OAM server;
- *hop-by-hop security via SEG in EPC* which is particularly suited for multiple management connections to separate OAM servers located within one "management domain".

If IKEv2/IPsec or TLS with authentication based on certificates is used for the security association(s), the protocol profiles for IPsec in TS 33.210 [5] and for IKEv2 and TLS in TS 33.310 [6] and the certificate profiles given in TS 33.310 [6] should be followed.

NOTE 4: As the USIM-INI can be accessed by any UE, an attacker can use the USIM-INI to connect to the APN used for OAM in phase I. In case of end-to-end security the OAM server itself has to be secured accordingly. In the hop-by-hop case the SEG can defend against attacks (e.g. DoS attacks) carried out via this channel.

The RN requires IP connectivity for the management procedure to be able to reach the OAM server.

For the pre-shared key case in Phase I, IP connectivity can be established after step Ep2 with the RN attaching to an eNB like a normal UE using the USIM-RN.

For the certificate-based case in Phase I, IP connectivity established for enrolment purposes according to clause D.2.4 may be re-used, or, if not available, it may be established in the same ways as described in clause D.2.4.

Restrictions on the destinations the RN can reach shall apply if the communication with the OAM server prior to the RN attach procedure is based on USIM-INI. They shall be realized in the same way as described in clause D.2.4.

D.2.6 Certificate and subscription handling

Whenever the operator intends to prevent the RN from attaching to the network the operator shall bar the subscription relating to the USIM-RN in the HSS.

In the certificate-based case the barring of the subscription relating to the USIM-RN shall be performed also whenever the RN certificate has to be revoked, or whenever the UICC certificate has to be revoked and the RN is not configured to always check the UICC certificate against a CRL, cf. below.

In the pre-shared key case, the barring of the subscription relating to the USIM-RN may be performed also whenever the operator sees a risk that the pre-shared key between the USIM-RN and RN has been compromised.

NOTE 0: In the certificate-based case, checking the UICC certificate against a CRL and barring the subscription relating to the USIM-RN are not equivalent. The former could prevent the following attack while the latter could not: an attacker in possession of a compromised private key relating to the UICC certificate could get stolen RNs to work in his own network as then the attacker could use a fake UICC, with subscription data generated by himself, towards the RN to set up a secure channel. Subscription barring would not be effective in the attacker's network while the CRL check by the RN would ensure that the RN cannot attach as an RN to a network other than the one of the operator who provisioned the root certificate in the RN. If the operator deems the risk of such an attack low he may configure his RNs to not use CRL checks against UICC certificates.

NOTE 0a: In the pre-shared key case, the proprietary measures may need to consider the attack described in the preceding NOTE 0.

The remainder of this subclause applies only to the certificate-based case.

As described in clause D.2.2, step Ec6, the certificate validation client on the UICC verifies the signatures in the RN certificate chain up to the root certificate, but omits the check of revocation status and expiry time. To achieve the same effect as checking RN certificate's revocation status and expiry time, the associated USIM-RN subscription shall be barred in the HSS. This process is called 'invalidation' in this document and is explained further below.

A certificate validation client on the RN shall check the verification of the signatures in the UICC certificate chain up to the root certificate as well as the expiry time. The revocation status of the UICC certificate should be checked by means of the CRL obtained by the RN in clause D.2.2, step Ec3. The CRL check is optional to support by the RN.

Further considerations on RN certificate and USIM-RN subscription handling:

By using the one-to-one binding of RN and USIM-RN, a part of the usual certificate handling is replaced by subscription handling, as explained below:

Binding in network: The one-to-one binding of RN and USIM-RN shall be expressed by a one-to-one mapping of the RN identity in any certificate issued to the RN and the IMSI in the USIM-RN. The operator shall maintain a table with this mapping (the "mapping table").

Binding in UICC: cf. clause D.2.3.

Lifetime: The subscription shall have a limit on its lifetime. When the lifetime of the subscription is exceeded the subscription shall be barred in the HSS. The lifetime shall not be greater than the lifetime of the RN certificate. The latter is not checked in the UICC, cf. clause D.2.2.

RN Certificate revocation and invalidation: Whenever the operator decides that the RN certificate shall no longer be used for setting up a secure channel with the USIM-RN the operator does not use CRLs or OCSP, but shall retrieve the IMSI associated with the subject name in the RN certificate and bar the subscription corresponding to the IMSI in the HSS. The certificate shall also be revoked, but the operator does not need to use CRLs or OCSP in this context. This implies that no new certificate shall be issued for the same RN identity from that point onwards. In case the RN certificate is also used for other purposes, e.g. for protecting an OAM connection, then, additionally, the usual PKI revocation procedures apply.

RN compromise: If the operator has reason to believe that an RN has been compromised the RN certificate shall be invalidated and revoked as described above.

RN Certificate renewal: This process may be used as normal as long as the RN identity in the RN certificate remains the same.

NOTE 1: Certificate renewal with private key change may be useful even if the UICC does not check the expiry time of the certificate as, in this way, the use of the private key can be limited if desired.

RN Certificate expiry:

NOTE 2: As the UICC has no clock it cannot check the expiry time and, hence, the RN could also use an expired certificate in the secure channel set-up. As the certificate is only checked by the UICC for RN platform authentication in the secure channel set-up this is not a problem as long as the corresponding private key has not left the secure environment of the RN. More generally, if there is a risk that it has been compromised the operator will bar the corresponding subscription in the HSS. The use of the certificate is limited by the lifetime of the subscription bound to the RN. However, a UICC can be re-used with a different RN after having been re-configured with a different RN identity.

D.3 Secure channel profiles

D.3.1 General

The clause D.3 profiles the algorithms to be used on the APDU secure channel, cf. ETSI TS 102 484 [29]. In addition it specifies the profiles for the different key agreement methods.

For the case when certificates are used for key agreement, the profiles are given for the TLS handshake used to provide key material for the Master SA of the secure channel between USIM-RN and RN, and for the certificates used in UICC and RN for mutual authentication during TLS handshake. For the psk case requirements on the key agreement with pre-shared keys are given.

D.3.2 APDU secure channel profile

For communication between the USIM-RN and the RN a secure channel according to the APDU secure channel as specified in ETSI TS 102 484 [29] shall be used. Further detailing of the secure channel is given in TS 31.102 [13].

For encryption, AES-CBC as specified in ETSI TS 102 484 [29] shall be mandatory to support. Other encryption algorithms specified in ETSI TS 102 484 [29] may be supported. The algorithm "3DES - outer CBC using 2 keys" shall not be used.

NOTE 1: The algorithm "3DES - outer CBC using 2 keys" is outdated.

For integrity protection, AES-CMAC as specified in ETSI TS 102 484 [29] shall be mandatory to support. Other integrity protection algorithms specified in ETSI TS 102 484 [29] shall not be used.

NOTE 2: The algorithm CRC32 is for redundancy check only, and not a cryptographic checksum. The algorithm "ANSI Retail MAC" is not fit for long-term usage in the scope of the present document.

D.3.3 Key agreement based on certificate exchange

D.3.3.1 TLS profile

The key agreement for the certificate exchange case shall follow the mechanism "Certificate exchange" as specified in ETSI TS 102 484 [29].

During key agreement based on certificate exchange a TLS handshake is used to provide key material for the Master SA of the APDU secure channel between USIM-RN and RN.

The TLS profile shall follow the profile given in Annex E of TS 33.310 [6] with the following restrictions and extensions:

- the support of the ciphersuite mandatory for TLS 1.1 as described in TS 33.310 [6] is not required;
- the support of fallback to TLS 1.0 as described in TS 33.310 [6] is not required;
- neither UICC nor RN shall use TLS session resumption.

D.3.3.2 Common profile for RN and UICC certificate

The certificate profile for both RN and UICC certificates shall follow the TLS entity certificate profile given in clause 6.1.3a of TS 33.310 [6] with the following restrictions and extensions:

- the support of the SHA-1 algorithm for use before signing the certificate as described in TS 33.310 [6] is not required;
- the support of public key length of 1024-bit is not required;

- only the subject name format with "(C=<country>), O=<Organization Name>, CN=<Some distinguishing name>" is mandatory to support.

D.3.3.3 RN certificate profile

The RN certificate is used as client certificate in the TLS handshake between RN and UICC.

The certificate profile for the RN certificate shall follow clause D.3.3.2 of the present document with the following restrictions and extensions:

- the subject name shall be unique within all subject names issued by CAs under the same root CA;
- the subject name may additionally contain the attribute "serialNumber=<serial number>";
- the support of the countryName (C) and serialNumber attributes in the subject name is mandatory;

NOTE 1: The usage of the countryName (C) and serialNumber attributes can support the operator in generating a unique identity for an RN.

- the CRL distribution point is not used if the RN certificate is only used in the setup of the secure channel with the UICC. Therefore the CRL distribution point is optional in this case.

NOTE 2: It may be desired to deploy the same RN certificate also for RN platform authentication to other network elements of the operator, e.g. if TLS with mutual authentication is used for an OAM connection. The profile given above is intended to allow such usage. Regarding the implementation of certificate handling in the UICC it should be noted that for this additional usage of the RN certificate the existence of additional fields in the certificate is possible, e.g. of the subjectAltName and/or the CRL distribution point, which are not relevant for the secure channel between RN and UICC.

D.3.3.4 UICC certificate profile

The UICC certificate is used as server certificate in the TLS handshake between RN and UICC.

The certificate profile for the UICC certificate shall follow clause D.3.3.2 of the present document with the following additional provisions:

- the CRL distribution point in the UICC certificate is optional.

NOTE 1: The CRL distribution point and the support for CRL infrastructure for the UICC certificate is only needed if the revocation check of the UICC certificate is performed during setup of the secure channel (cf. clause D.2.6).

NOTE 2: In common TLS usage, the RN learns the UICC certificate only during TLS handshake, when the IP connectivity to the core network using USIM-INI may no longer be available. Thus the CRL distribution point for CRLs having UICC certificates in scope would be known too late to allow the RN to retrieve an up-to-date CRL from the network. By reading the UICC certificate from the UICC before the establishment of the secure channel starts, the RN may learn the CRL distribution point while it still has IP connectivity based on USIM-INI, cf. step Ec3 in clause D.2.2. For access to the UICC certificate see the definition of the EF for UICC certificate in TS 31.102 [13].

D.3.4 Key agreement for pre-shared key (psk) case

The key agreement for the psk case shall follow the mechanism "Strong Pre-shared Keys - Proprietary Pre-agreed keys" as specified in ETSI TS 102 484 [29]. The pre-shared key shall be used directly to derive a Master secret for the Master SA.

NOTE: The above requirement includes that the pre-shared key fulfills the requirements for WeakKey=0 as specified in clause 7.2 of ETSI TS 102 484 [29].

D.3.5 Identities used in key agreement

The key agreement mechanisms specified in ETSI TS 102 484 [29] produce a value `Ks_Local_Ref`, which is a reference to `Ks_local`. It is transferred from the RN to the UICC during the Master SA setup and is used as input to the derivation of the 256 bit Master secret (MS) of the Master SA in the certificate exchange case.

`Ks_Local_Ref` is specified in ETSI TS 102 484 [29] as the concatenation of identities as follows:

$$\text{Ks_Local_Ref} = \text{Terminal_ID} \parallel \text{Terminal_appli_ID} \parallel \text{UICC_ID} \parallel \text{UICC_appli_ID}.$$

The identities used in the scope of the present document for `Ks_Local_Ref` are specified as follows:

- `UICC_ID`: This unique identifier for the UICC shall be the ICCID for the UICC as specified in ETSI TS 102 221 [32].

NOTE: The `UICC_ID` may be read by the RN from the UICC before establishment of the secure channel.

- `UICC_appli_ID`: This unique identifier for the UICC application that hosts the UICC endpoint shall be the USIM-RN AID as specified in TS 31.102 [13].
- `Terminal_ID`: This unique identifier for the RN shall be the subject name of the RN certificate as specified in clause D.3.3.3. In the psk case, where no certificate is used, the same definition as for the certificate exchange case shall apply.
- `Terminal_appli_ID`: This unique identifier for the application that hosts the RN side endpoint shall be set to the UTF-8 encoded string "Relay_Node_appli".

Annex E (normative): Dual connectivity

E.1 Introduction

E.1.1 General

This clause describes the security functions necessary to support a UE that is simultaneously connected to more than one eNB for the architectures for dual connectivity as described in TS 36.300 [30]. The security functions are described in the context of the functions controlling the dual connectivity.

E.1.2 Dual Connectivity architecture with an SeNB

For dual connectivity architecture, which hosts PDCP in MeNB the security functions described for the single connectivity mode in this specification are sufficient. The reason for that they are sufficient, is that the end-point for the encryption remains in the MeNB. That is, from a security point of view, the PDCP packets are still processed in the same locations in the architecture; they have only travelled a different path via the SeNB.

The remainder of the present subclause deals with dual connectivity between an MeNB and an SeNB with the architecture as shown in Figure E.1. 2-1.

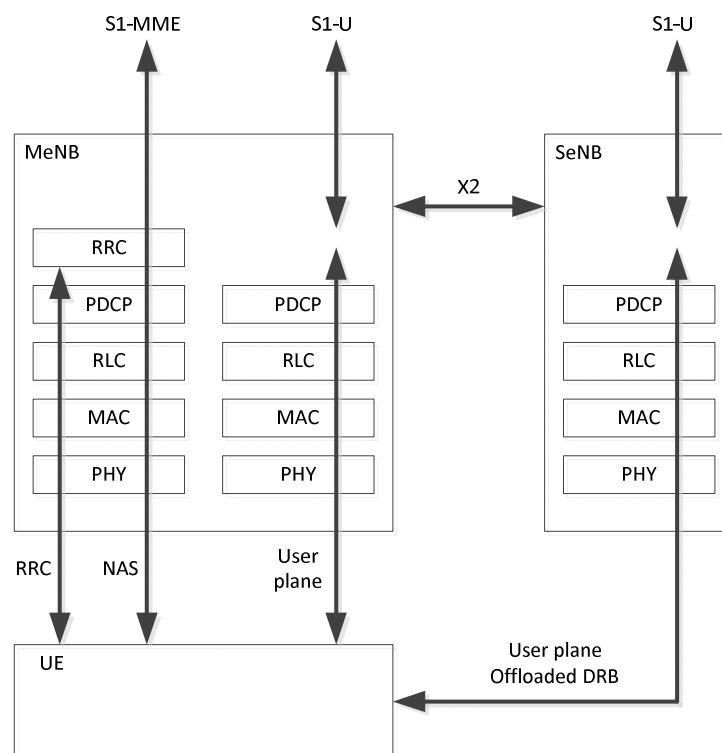

Figure E.1.2-1: Dual Connectivity architecture with an SeNB

When the MeNB establishes security between an SeNB and the UE for the first time for a given AS security context shared between the MeNB and the UE, the MeNB generates the $S-K_{eNB}$ for the SeNB and sends it to the SeNB over the X2-C. To generate the $S-K_{eNB}$, the MeNB associates a counter, called an SCG Counter, with the current AS security context. The SCG Counter is used as freshness input into $S-K_{eNB}$ derivations as described in the clause E.2.4, and guarantees, together with the other provisions in the present clause E, that the K_{UPenc} derived from the same $S-K_{eNB}$ is not re-used with the same input parameters as defined in Annex B of the present specification. The latter would result in

key-stream re-use. The MeNB sends the value of the SCG Counter to the UE over the RRC signalling path when it is required to generate a new $S-K_{eNB}$.

The communication established between the SeNB and the UE is protected at the PDCP layer using the AS Secondary Cell security context, or AS SC security context for short. The AS SC security context includes parameters as the AS security context described in clause 7 of the present specification, the $S-K_{eNB}$ replaces the K_{eNB} . The UE and the SeNB derives the K_{UPenc} from the $S-K_{eNB}$ as described in clause A.7, cf. also E.2.4.2.

E.1.3 Dual Connectivity architecture with an SgNB

Annex E.3 describes the security functions necessary to support a UE that is simultaneously connected to eNB as master and gNB as secondary for EN-DC dual connectivity. The description in Annex E.3 is focused on the difference from dual connectivity in E-UTRAN described in Annex E.2. The major differences are

- with dual connectivity between an MeNB and an SgNB compared to between an MeNB and an SeNB is that in the former case a RRC signalling connection is allowed between the UE and the SgNB. Such a RRC signalling connection shall be integrity protected in addition to the ciphered with the chosen ciphering algorithm;
- EPS bearers from the core network to the SgNB may be Split across the radio resources of both MeNB and SgNB (as well as being Non-Split and only using radio resources of the SgNB); and
- for bearers whose PDCP terminates in the MeNB, the security functions described for the single connectivity mode in this specification shall be used, while for bearers whose PDCP terminates in the SgNB, the security algorithm given in subclause E.3.10.1 with key derived as given in clause A.19 shall be used.

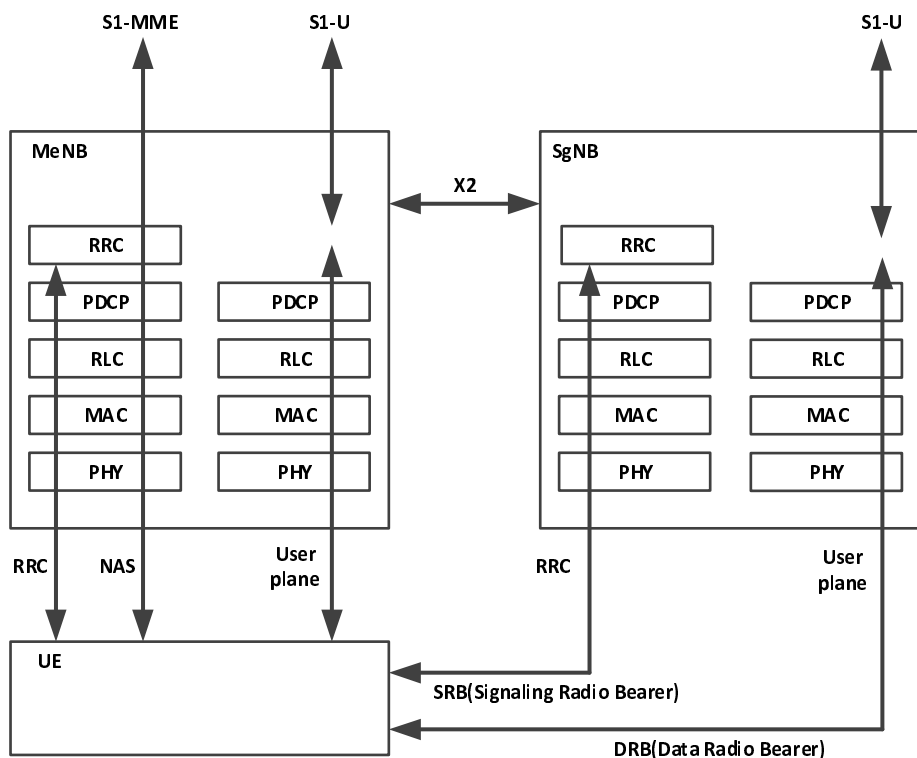

Figure E.1.3-1 Offload architecture for EN-DC

When the MeNB establishes security between a SgNB and the UE for the first time for a given AS security context shared between the MeNB and the UE, the MeNB generates the $S-K_{gNB}$ (exactly as it would generate an $S-K_{eNB}$) for the SgNB and sends it to the SgNB over the X2-C. The SCG Counter is also used as freshness input into $S-K_{gNB}$ derivations as described in the clause E.2.4, and guarantees, together with the other provisions in the present clause E, that the integrity and ciphering keys used at the SgNB derived from the same $S-K_{gNB}$ are not re-used with the same input parameters to avoid in key-stream re-use and provide replay protection. The MeNB sends the value of the SCG Counter to the UE over the LTE RRC signalling path when it is required to generate a new $S-K_{gNB}$.

The communication established between the SgNB and the UE is protected at the PDCP layer using the SgNB Secondary Cell security context, or SgNB SC security context for short. The SgNB SC security context includes $S\text{-}K_{\text{gNB}}$, the key used as input to the UP confidentiality algorithm, $K_{\text{SgNB-UP-enc}}$, the key used as the input to the RRC confidentiality algorithm, $K_{\text{SgNB-RRC-enc}}$, the key used as the input for the RRC integrity algorithm, $K_{\text{SgNB-RRC-int}}$, the identifiers of the selected cryptographic algorithms and counters used for replay protection. Although the SgNB may support the UP integrity protection algorithms and the capability of activating the UP integrity protection using the RRC protocol between the UE and the SgNB, the UP integrity protection is not activated. The UE and the SgNB derives the integrity and ciphering keys from the $S\text{-}K_{\text{gNB}}$ as described in clause A.19, cf. also E.3.4.2.

E.2 Dual connectivity offload architecture between eNBs

E.2.1 Protection of the X2 reference point

The control plane signalling between MeNB and SeNB, that includes the transfer of the $S\text{-}K_{\text{eNB}}$ from the MeNB to the SeNB, over the X2 reference point shall be confidentiality and integrity protected using X2-C security protection as described in clause 5.3.4a and clause 11 of the present specification. Any user plane data between MeNB and SeNB over X2 reference point shall be confidentiality and integrity protected using X2-U security protection as described in clause 5.3.4 and clause 12 of the present specification.

E.2.2 Addition and modification of DRB in SeNB

When executing the SeNB Addition procedure (i.e. the initial offload of one or more radio bearers to the SeNB), or the SeNB Modification procedure requiring an update of $S\text{-}K_{\text{eNB}}$, the MeNB shall derive an $S\text{-}K_{\text{eNB}}$ as defined in clause E.2.4, which results in a fresh $S\text{-}K_{\text{eNB}}$. The MeNB shall forward the generated $S\text{-}K_{\text{eNB}}$ to the SeNB during the SeNB Addition procedure or SeNB Modification procedure requiring key update.

Note: Refer to TS 36.300 [30] for definition of the SeNB Addition and SeNB Modification procedures.

The SeNB shall derive a key K_{UPenc} from the received $S\text{-}K_{\text{eNB}}$ as defined in clause E.2.4 of the present specification and use it for all radio bearers that were being added.

At any point of time, the same K_{UPenc} is used for encrypting all radio bearers between the SeNB and the UE. Once the K_{UPenc} has been derived from the $S\text{-}K_{\text{eNB}}$, the SeNB and UE may delete the $S\text{-}K_{\text{eNB}}$.

The MeNB shall provide the value of the SCG Counter used in the derivation of the $S\text{-}K_{\text{eNB}}$ to the UE in the SeNB Addition procedure adding the radio bearer(s) in the UE. The UE shall derive the $S\text{-}K_{\text{eNB}}$ and K_{UPenc} as described in clause E.2.4.

When executing the procedure for adding subsequent radio bearer(s) to the same SeNB, the MeNB shall, for each new radio bearer, assign a radio bearer identity that has not previously been used since the last $S\text{-}K_{\text{eNB}}$ change.

If the MeNB cannot allocate an unused radio bearer identity for a new radio bearer in the SeNB, due to radio bearer identity space exhaustion, the MeNB shall increment the SCG Counter and compute a fresh $S\text{-}K_{\text{eNB}}$, and then shall perform a SeNB Modification procedure to update the $S\text{-}K_{\text{eNB}}$. The MeNB may choose to update the $S\text{-}K_{\text{eNB}}$ instead of assigning a new radio bearer identity even when the latter would have been possible.

If the SeNB receives a new $S\text{-}K_{\text{eNB}}$ from the MeNB during the SeNB Modification procedure, the SeNB shall use the K_{UPenc} derived from the new $S\text{-}K_{\text{eNB}}$ as encryption key for all the radio bearer (s).

If the UE receives a new SCG Counter in SeNB Addition/Modification procedure, then the UE shall use the K_{UPenc} derived from the new $S\text{-}K_{\text{eNB}}$, as the encryption key for all the radio bearer(s) established with the SeNB.

When the last radio bearer on the SeNB is released, the SeNB Release procedure is performed; the SeNB and the UE shall delete the K_{UPenc} . The SeNB and UE shall also delete the $S\text{-}K_{\text{eNB}}$, if it was not deleted earlier.

E.2.3 Activation of encryption/decryption

The DRB offload procedure with activation of encryption/decryption follows the steps outlined on the Figure E.2.3-1.

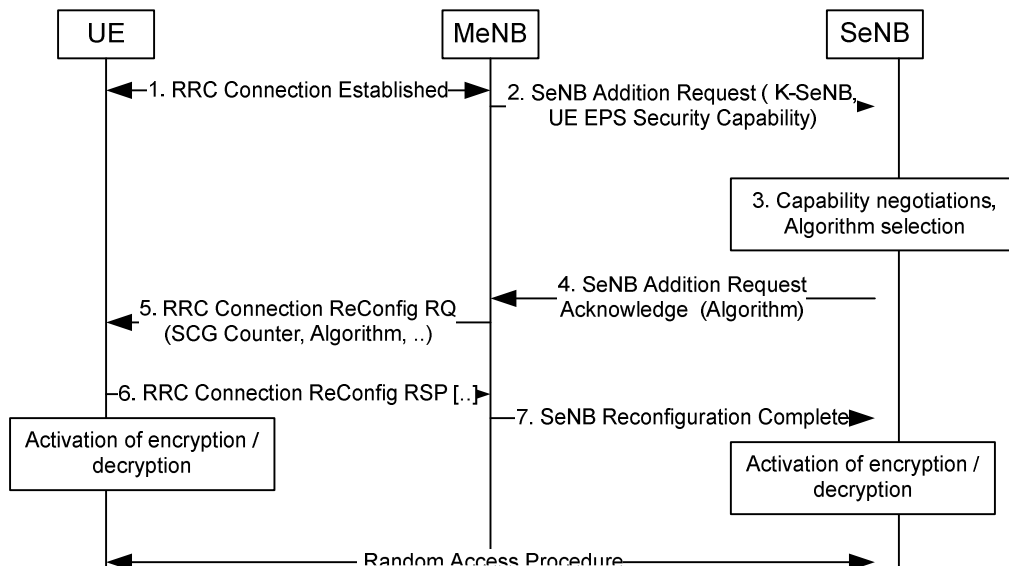

Figure E.2.3-1. SeNB encryption/decryption activation

1. The UE and the MeNB establish the RRC connection.
2. The MeNB decides to offload the DRB(s) to the SeNB. The MeNB sends SeNB Addition Request to the SeNB over the X2-C to negotiate the available resources, configuration, and algorithms at the SeNB. The MeNB computes and delivers the $S\text{-}K_{eNB}$ to the SeNB as necessary. UE EPS security capability should also be sent to SeNB.
3. The SeNB allocates the necessary resources and chooses the ciphering algorithm which has the highest priority from its configured list and is also present in the UE EPS security capability.
4. The SeNB sends SeNB Addition Request Acknowledge to the MeNB indicating availability of requested resources and the identifiers for the selected algorithm to serve the requested DRB for the UE.
5. The MeNB sends the RRC Connection Reconfiguration Request to the UE instructing it to configure a new DRB for the SeNB. The MeNB shall include the SCG Counter parameter to indicate that the UE shall compute the $S\text{-}K_{eNB}$ for the SeNB and the K_{UPenc} associated with the assigned bearer. The MeNB forwards the UE configuration parameters (which contains the algorithm identifier received from the SeNB in step 4) to the UE (see section E.2.4.3 for further details).

NOTE: Since the message is sent over the RRC connection between the MeNB and the UE, it is integrity protected using the K_{RRCint} of the MeNB. Hence the SCG Counter cannot be tampered with, and the UE can assume that it is fresh.

6. The UE accepts the RRC Connection Reconfiguration Command and shall compute the $S\text{-}K_{eNB}$ for the SeNB. The UE shall also compute the K_{UPenc} for the associated assigned DRB on the SeNB. The UE sends the RRC Reconfiguration Complete to the MeNB. The UE activates encryption/decryption once $S\text{-}K_{eNB}$ and K_{UPenc} are derived.
7. MeNB sends SeNB Reconfiguration Complete to the SeNB over the X2-C to inform SeNB configuration result. On receipt of this message, SeNB may activate encryption/decryption with UE. If SeNB does not activate encryption/decryption with the UE at this stage, SeNB shall activate encryption/decryption upon receiving the Random Access request from the UE.

E.2.4 Derivation of keys for the DRBs in the SeNB

E.2.4.1 SCG Counter maintenance

The MeNB shall associate a 16-bit counter, SCG Counter, with the EPS AS security context.

The SCG Counter is used when computing the $S\text{-}K_{eNB}$. The UE and the MeNB shall treat the SCG Counter as a fresh input to $S\text{-}K_{eNB}$ derivation. That is, the UE assumes that the MeNB provides a fresh SCG Counter each time and does not need to verify the freshness of the SCG Counter.

NOTE: An attacker cannot, over the air modify the SCG Counter and force re-use of the same SCG Counter. The reason for this is that the SCG Counter is delivered over the RRC connection between the MeNB and the UE, and this connection is both integrity protected and protected from replay.

The MeNB maintains the value of the counter SCG Counter for a duration of the current AS security context between UE and MeNB. The UE does not need to maintain the SCG Counter after it has computed the $S\text{-}K_{eNB}$ since the MeNB provides the UE with the current SCG Counter value when the UE needs to compute a new $S\text{-}K_{eNB}$.

The MeNB that supports the DRB offload shall set the SCG Counter to '0' when the K_{eNB} in the associated AS security context is established. The MeNB shall set the SCG Counter to '1' after the first calculated $S\text{-}K_{eNB}$, and monotonically increment it for each additional calculated $S\text{-}K_{eNB}$. The SCG Counter value '0' is hence used to calculate the first $S\text{-}K_{eNB}$.

If the MeNB decides to turn off the offload connection and later decides to re-start the offloading to the same SeNB, the SCG Counter value shall keep increasing, thus keeping the computed $S\text{-}K_{eNB}$ fresh.

The MeNB shall refresh the K_{eNB} of the AS security context associated with the SCG Counter before the SCG Counter wraps around. Re-freshing the K_{eNB} is done using intra cell handover as described in clause 7.2.9.3 of the present specification. When this K_{eNB} is refreshed, the SCG Counter is reset to '0' as defined above.

E.2.4.2 Security key derivation

The UE and MeNB shall derive the security key $S\text{-}K_{eNB}$ of the target SeNB as defined in Annex A.15 of the present specification.

The addition to the LTE key hierarchy with derivation of the $S\text{-}K_{eNB}$ is shown on Figure E.2.4.2-1.

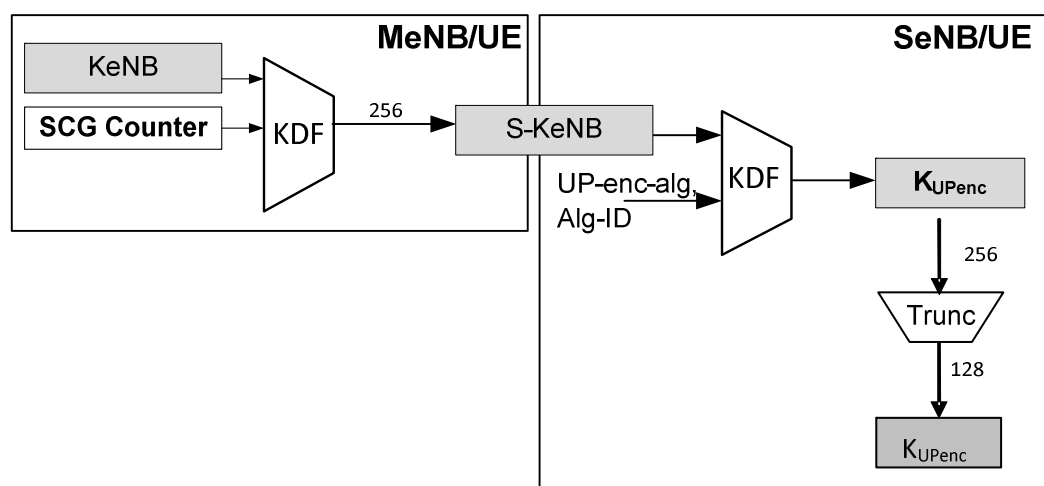

Figure E.2.4.2-1 Addition to the Key Hierarchy for the SeNB

The SeNB and the UE shall further derive the ciphering key K_{UPenc} for ciphering of the User Plane over the DRB. This derivation is performed according to Annex A.7 using the $S-K_{eNB}$ as the input key and the input string S formed using the IDs of the SeNB selected algorithm to the KDF.

NOTE: In the present specification, only a user plane encryption key is required between UE and SeNB. But the key derivation procedure permits deriving further keys according to Annex A.7 if this should be desired in the future.

E.2.4.3 Negotiation of security algorithms

When establishing one or more DRBs for a UE at the SeNB, as shown on Figure E.2.3-1, the MeNB shall forward the UE EPS security capabilities associated with the UE in the SeNB Addition/Modification procedure.

Upon receipt of this message, the SeNB shall identify the AS encryption algorithm with highest priority in the locally configured priority list of AS encryption algorithms that is also present in the received UE EPS security capabilities and include an indicator for the locally identified AS encryption algorithm in SeNB Addition/Modification Request Acknowledge.

The MeNB shall forward the indication to the UE during the RRCConnectionReconfiguration procedure that establishes the SCG DRBs in the UE. The UE shall use the indicated encryption algorithm for the SCG DRBs.

NOTE: The UE uses one encryption algorithm for encryption of SRB and any potential DRB(s) established with MeNB, and a same or different encryption algorithm for encryption of DRB(s) established with SeNB.

E.2.5 $S-K_{eNB}$ update

E.2.5.1 $S-K_{eNB}$ update triggers

The system supports update of the $S-K_{eNB}$. The MeNB may update the $S-K_{eNB}$ for any reason by using the $S-K_{eNB}$ update procedure defined in clause E.2.5.2 of the current specification. The SeNB shall request the MeNB to update the $S-K_{eNB}$ over the X2-C, when uplink or downlink PDCP COUNTs are about to wrap around for any of the DRBs.

If the MeNB re-keys its currently active K_{eNB} in an AS security context the MeNB shall update any $S-K_{eNB}$ associated with that AS security context. This retains the two-hop security property for X2-handovers.

E.2.5.2 $S-K_{eNB}$ update procedure

If the MeNB receives a request for $S-K_{eNB}$ update from the SeNB or decides on its own to perform $S-K_{eNB}$ update (see clause E.2.5.1), the MeNB shall compute a fresh $S-K_{eNB}$ and increment the SCG Counter, as defined in clause E.2.4. Then the MeNB shall perform a SeNB Modification procedure to deliver the fresh $S-K_{eNB}$ to the SeNB. The MeNB shall provide the value of the SCG Counter used in the derivation of the $S-K_{eNB}$ to the UE in an integrity protected RRC procedure. The UE shall derive the $S-K_{eNB}$ and K_{UPenc} as described in clause E.2.4.

Whenever the UE or SeNB start using a fresh $S-K_{eNB}$, they shall re-calculate the K_{UPenc} from the fresh $S-K_{eNB}$.

E.2.6 Handover procedures

During S1 and X2 handover, the offloaded DRB connection between the UE and the SeNB is released, and the AS SC security context at SeNB and UE can be deleted since it shall not be used again.

E.2.7 Periodic local authentication procedure

SeNB may request the MeNB to execute a counter check procedure specified in clause 7.5 of this specification to verify the value of the PDCP COUNT(s) associated with DRB(s) offloaded to the SeNB. To accomplish this, the SeNB shall communicate this request, including the expected values of PDCP COUNT(s) and associated radio bearer identities (which are identified by E-RAB Id(s) in X2AP), to the MeNB over the X2-C.

If the MeNB receives a RRC counter check response from the UE that contains one or several PDCP COUNT values (possibly associated with both MeNB and SeNB), the MeNB may release the connection or report the difference of the PDCP COUNT values to the serving MME or O&M server for further traffic analysis for e.g. detecting the attacker.

E.2.8 Radio link failure recovery

Since the MeNB holds the control plane functions even in dual connectivity, the UE runs the RRC re-establishment procedure with the MeNB as specified in clause 7.4.3 of the present specification.

NOTE: During the RRC re-establishment procedure, the DRB(s) offloaded between the UE and the SeNB is (are) released. If MeNB still want to offload DRB(s) to SeNB, SeNB addition is performed as specified in E.2.2.

E.2.9 Avoiding key stream reuse caused by DRB type change

When a MCG DRB changes to SCG DRB and then changes back to MCG DRB, the key stream reuse is possible. MeNB shall implement a mechanism to prevent key stream reuse.

E.3 Dual connectivity architecture between a MeNB and a SgNB

E.3.1 Protection of the X2 reference point

The protection of X2 interface shall use the X2-C security and X2-U security as described in subclause E.2.1 of the present document.

E.3.2 Addition and modification of DRBs and/or SRB in SgNB

The $S-K_{eNB}$ that is used for dual connectivity between eNBs (see subclause E.2.3) is also used as the root for the security context at the SgNB. When used in the contexts of dual connectivity with an SgNB, the key shall be called an $S-K_{gNB}$, i.e. the MeNB generates and forwards an $S-K_{gNB}$ to the SgNB during the SgNB Addition procedure or SgNB Modification procedure requiring key update.

NOTE 1: Refer to TS 36.300 [30] for definition of the SgNB Addition and SgNB Modification procedures.

Similarly, the MeNB handles the SCG Counter due to interactions with a SgNB as described in subclause E.2.2 for interactions with SeNBs, i.e. this is a single shared SCG Counter for SeNBs and SgNBs and provides the same value of SCG Counter used to the UE and ensure that fresh radio bearer identities are used or the $S-K_{gNB}$ is refreshed.

When the SgNB receives an $S-K_{gNB}$ in a SgNB Addition/Modification procedure, the SgNB shall derive and store $K_{SgNB-UP-enc}$ as well as $K_{SgNB-RRC-int}$ and $K_{SgNB-RRC-enc}$ if an SRB is to be added as described in subclause E.3.4.2 from the received $S-K_{gNB}$. These freshly derived keys are then used to protect all the radio bearer(s) that use the PDCP of the SgNB. Any previous such keys shall be deleted. If all the keys were derived, then the $S-K_{gNB}$ may be deleted.

NOTE 2: The UP integrity protection is not activated in SgNB when connected to EPC.

If the UE receives a new SCG Counter in SgNB Addition/Modification procedure, then the UE shall derive a new $S-K_{gNB}$ from this SCG Counter and use $K_{SgNB-UP-enc}$, $K_{SgNB-RRC-int}$ and $K_{SgNB-RRC-enc}$ derived from the new $S-K_{gNB}$, as the keys to protect all the radio bearer(s) using the PDCP of the SgNB. If all the keys were derived, then the $S-K_{gNB}$ may be deleted in the UE.

When the SgNB Release procedure releases the last radio bearer on the SgNB, the SgNB and the UE shall delete the $K_{SgNB-UP-enc}$, $K_{SgNB-RRC-int}$ and $K_{SgNB-RRC-enc}$. The SgNB and UE shall also delete the $S-K_{gNB}$, if it was not deleted earlier.

E.3.3 Activation of encryption/decryption of DRBs and encryption/decryption/integrity protection of SRB

The dual connectivity procedure with activation of encryption/decryption of Split and/or Non-Split SgNB terminated DRB(s) (i.e. a DRB for which PDCP is located in the SgNB) and/or activation of encryption/decryption and integrity protection of an SgNB terminated SRB (i.e. a SRB for which PDCP is located in the SgNB) follows the steps outlined on the Figure E.3.3-1.

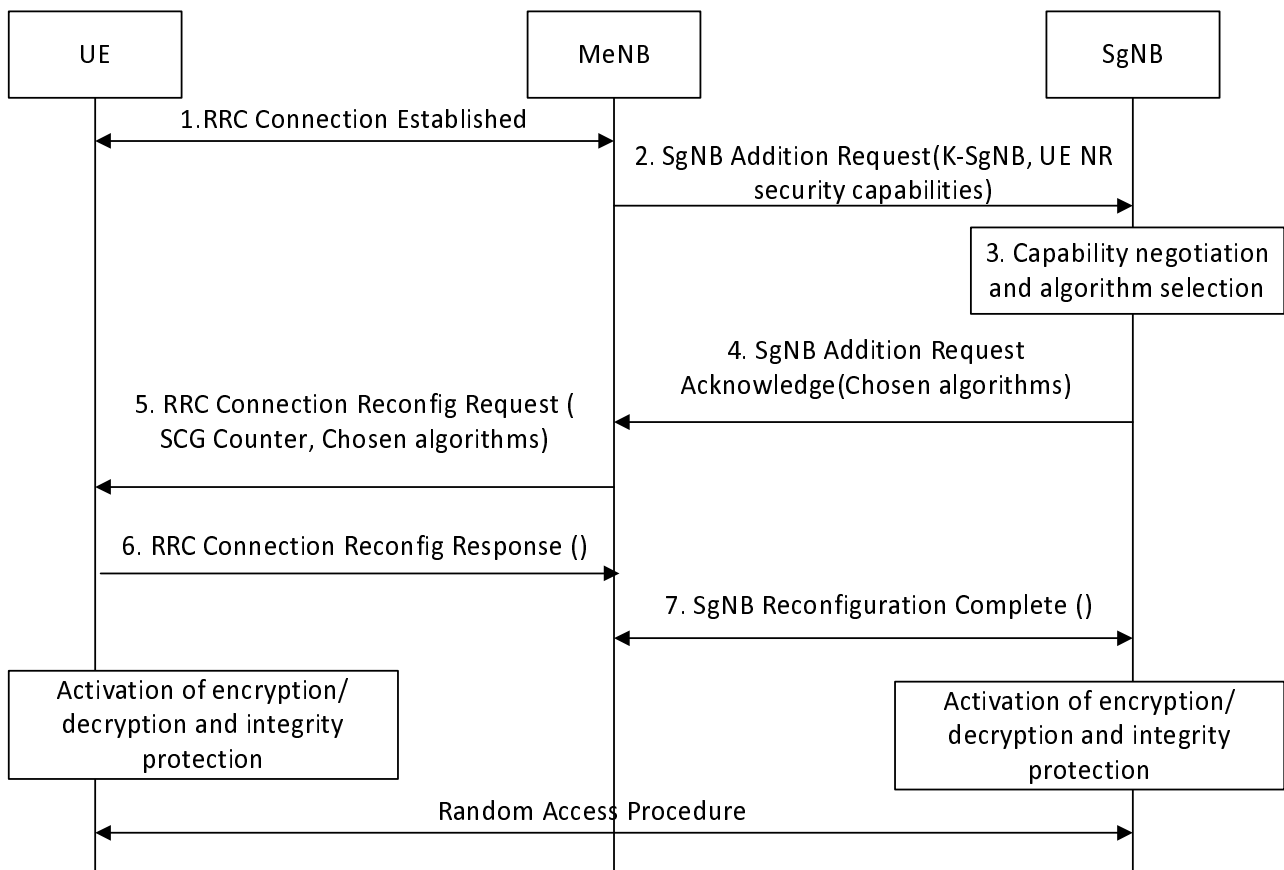

Figure E.3.3-1. SgNB encryption/decryption and integrity protection activation

1. The UE and the MeNB establish the RRC connection.
2. Before the MeNB decides to use dual connectivity for some DRB(s) and/or an SRB with the SgNB, the MeNB shall check whether the UE has NR capability and is authorized to access NR. The MeNB sends SgNB Addition Request to the SgNB over the X2-C to negotiate the available resources, configuration, and algorithms at the SgNB. When connected to EPC, the MeNB shall indicate to the SgNB that UP integrity protection shall not be activated. The MeNB computes and delivers the $S\text{-}K_{\text{SgNB}}$ to the SgNB if a new key is needed. The UE NR security capability shall also be sent to SgNB.

NOTE 1: Void.

NOTE 2: The UP integrity protection is not activated in SgNB when connected to EPC.

3. The SgNB allocates the necessary resources and chooses the ciphering algorithm for the DRB(s) and SRB and integrity algorithm if an SRB is to be established which has the highest priority from its configured list and is also present in the UE NR security capability. If a new $S\text{-}K_{\text{SgNB}}$ was delivered to the SgNB, then the SgNB calculates $K_{\text{SgNB-UP-enc}}$ as well as $K_{\text{SgNB-RRC-int}}$ and $K_{\text{SgNB-RRC-enc}}$ if an SRB is to be established.
4. The SgNB sends SgNB Addition Request Acknowledge to the MeNB indicating availability of requested resources and the identifiers for the selected algorithm(s) to serve the requested DRBs and/or SRB for the UE.

5. The MeNB sends the RRC Connection Reconfiguration Request to the UE instructing it to configure the new DRBs and/or SRB for the SgNB. The MeNB shall include the SCG Counter parameter to indicate that the UE shall compute the $S\text{-}K_{\text{gNB}}$ for the SgNB if a new key is needed. The MeNB forwards the UE configuration parameters (which contains the algorithm identifier(s) received from the SgNB in step 4) to the UE (see section E.3.4.3 for further details).

NOTE 3: Since the message is sent over the RRC connection between the MeNB and the UE, it is integrity protected using the K_{RRCint} of the MeNB. Hence the SCG Counter cannot be tampered with, and the UE can assume that it is fresh.

6. The UE accepts the RRC Connection Reconfiguration Command. The UE shall compute the $S\text{-}K_{\text{gNB}}$ for the SgNB if an SCG Counter parameter was included. The UE shall also compute $K_{\text{SgNB-UP-enc}}$ as well as $K_{\text{SgNB-RRC-int}}$ and $K_{\text{SgNB-RRC-enc}}$ for the associated assigned DRBs and/or SRB. The UE sends the RRC Reconfiguration Complete to the MeNB. The UE activates the chosen encryption/decryption and integrity protection at this point.
7. MeNB sends SgNB Reconfiguration Complete to the SgNB over the X2-C to inform the SgNB of the configuration result. On receipt of this message, SgNB may activate the chosen encryption/decryption and integrity protection with UE. If SgNB does not activate encryption/decryption and integrity protection with the UE at this stage, SgNB shall activate encryption/decryption and integrity protection upon receiving the Random Access request from the UE.

E.3.4 Derivation of keys for RBs with PDCP in the SgNB

E.3.4.1 SCG Counter maintenance

The same SCG Counter is used for both SeNB and SgNB and the handling for SgNBs follow the procedures for SeNB given in E.2.4.1.

E.3.4.2 Security key derivation

The UE and MeNB shall derive the security key $S\text{-}K_{\text{gNB}}$ of the target SgNB as defined in Annex A.15 of the present specification. $K_{\text{SgNB-UP-enc}}$, $K_{\text{SgNB-RRC-int}}$ and $K_{\text{SgNB-RRC-enc}}$ are derived from the $S\text{-}K_{\text{gNB}}$ both at the SgNB side and the UE side as shown on Figure E.3.4.2-1 using the function given in Annex A.19.

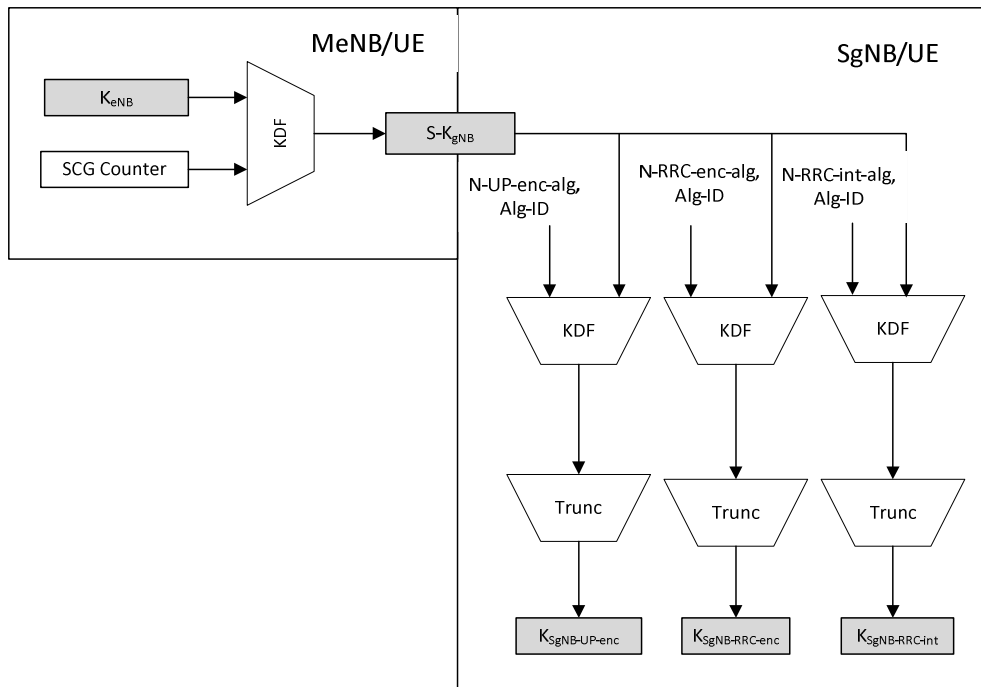

Figure E.3.4.2-1 Addition to the Key Hierarchy for the SgNB

E.3.4.3 Negotiation of security algorithms

The UE NR security capabilities shall be indicated to the network using a new IE so that the support of EPS and NR algorithms can evolve independently. The UE shall send the UE NR security capabilities to the MME in Attach Request and (when possibly changing MME) TAU Request. To enable the usage of NR EN-DC with an MME that does not understand the UE NR security capabilities in the new IE, such an MME will drop the UE NR security capabilities and never save them in its UE context. An eNB that does not receive the UE NR security capabilities shall use the E-UTRAN security capabilities algorithms to create the supported UE NR security capabilities (see Annex E.10.3.2 for more details).

An MME that has the UE NR security capabilities shall send the UE NR security capabilities to the eNB in the S1-Initial Context Set-up message.

At S1-handover if the target MME receives the UE NR security capabilities from the source MME, the target MME shall send the UE NR security capabilities to the target eNB in the S1-AP Handover Request

At X2 handover, if the source eNB has the UE NR security capabilities, the source eNB shall send the UE NR security capabilities to the target eNB. These UE NR security capabilities should be the same as received from the MME on the S1 interface.

After a handover, it is possible that an eNB may have not received the UE NR security capabilities as the UE may have just been handed over from an eNB or MME that does not support the UE NR security capabilities. To overcome such a possible problem, the eNB shall create the UE NR security capabilities from the supported E-UTRAN security algorithms. To do this, the eNB shall use the mapping between the E-UTRAN security algorithms and NR security algorithms as per Annex E.3.10.2. When adding SgNB while establishing an EN-DC connection, the MeNB shall send these created UE NR security capabilities to the SgNB. Other than for adding an SgNB, the created UE NR security capabilities shall not be sent from the MeNB.

A target eNB that has received the UE NR security capabilities during handover shall include the UE NR security capabilities in the S1-PATH SWITCH-REQUEST message.

If an MME does not receive the UE NR security capabilities in the S1-PATH-SWITCH-REQUEST message from the target eNB to which the UE is connected to, or if an MME becomes aware that the eNB doesn't know the UE NR

security capabilities after an S1-handover, the MME should send the UE NR security capabilities to the target eNB via the PATH SWITCH REQUEST ACKNOWLEDGE message as specified in TS 36.413 [42], and the the target eNB shall store the UE NR security capabilities in the UE context.

When establishing one or more DRBs and/or a SRB for a UE at the SgNB, as shown on Figure E.3.3-1, the MeNB shall send the UE NR security capabilities associated with the UE in the SgNB Addition/Modification procedure. Upon receipt of this message, the SgNB shall identify the needed algorithm(s) with highest priority in the locally configured priority list of algorithms that is also present in the received UE NR security capabilities and include an indicator for the locally identified algorithm(s) in SgNB Addition/Modification Request Acknowledge.

The MeNB shall forward the indication to the UE during the RRCConnectionReconfiguration procedure that establishes the SgNB terminated DRBs and/or SgNB terminated SRB in the UE. The UE shall use the indicated encryption algorithms for the SgNB terminated DRBs and/or SgNB terminated SRB and the indicated integrity algorithm for the SgNB terminated SRB.

NOTE: The UP integrity protection is not activated in SgNB when connected to EPC.

E.3.5 S-K_{gNB} update

E.3.5.1 S-K_{gNB} update triggers

The system supports update of the S-K_{gNB}. The MeNB may update the S-K_{gNB} for any reason by using the S-K_{gNB} update procedure defined in clause E.3.5.2 of the current specification. The SgNB shall request the MeNB to update the S-K_{gNB} over the X2-C, when uplink or downlink PDCP COUNTs are about to wrap around for any of the SgNB terminated DRBs or SgNB terminated SRB.

If the MeNB re-keys its currently active K_{eNB} in an AS security context the MeNB shall update any S-K_{gNB} associated with that AS security context. This retains the two-hop security property for X2-handovers.

E.3.5.2 S-K_{gNB} update procedure

If the MeNB receives a request for S-K_{gNB} update from the SgNB or decides on its own to perform S-K_{gNB} update (see clause E.3.5.1), the MeNB shall compute a fresh S-K_{gNB} and increment the SCG Counter, as defined in clause E.2.4. Then the MeNB shall perform a SgNB Modification procedure to deliver the fresh S-K_{gNB} to the SgNB. The MeNB shall provide the value of the SCG Counter used in the derivation of the S-K_{gNB} to the UE in an integrity protected RRC procedure. The UE shall derive the S-K_{gNB} as described in clause E.2.4.

Whenever the UE or SgNB start using a fresh S-K_{gNB}, they shall re-calculate K_{SgNB-UP-enc}, K_{SgNB-RRC-int} and K_{SgNB-RRC-enc} from the fresh S-K_{gNB}.

E.3.6 Handover procedures

During S1 and X2 handover, the DRB connection between the UE and the SgNB shall be released, and the AS SC security context at SgNB and UE shall be deleted since it shall not be used again.

E.3.7 Periodic local authentication procedure

SgNB may request the MeNB to execute a counter check procedure specified in clause 7.5 of this specification to verify the value of the PDCP COUNT(s) associated with DRB(s) offloaded to the SgNB. To accomplish this, the SgNB shall communicate this request, including the expected values of PDCP COUNT(s) and associated radio bearer identities (which are identified by E-RAB Id(s) in X2AP), to the MeNB over the X2-C.

If the MeNB receives a RRC counter check response from the UE that contains one or several PDCP COUNT values (possibly associated with both MeNB and SgNB), the MeNB may release the connection or report the difference of the PDCP COUNT values to the serving MME or O&M server for further traffic analysis for e.g. detecting the attacker.

E.3.8 Radio link failure recovery

Since the MeNB holds the control plane functions even in dual connectivity, the UE runs the RRC re-establishment procedure with the MeNB as specified in clause 7.4.3 of the present specification.

NOTE: During the RRC re-establishment procedure, the DRB(s) offloaded between the UE and the SgNB is (are) released. If MeNB still want to offload DRB(s) to SgNB, SgNB addition is performed as specified in E.3.2.

E.3.9 Avoiding key stream reuse caused by DRB type change

When a DRB changes from a MeNB terminated DRB (i.e. a DRB for which PDCP is located in the MeNB) to a SgNB terminated DRB and then changes back to a MeNB terminated DRB, then key stream reuse is possible. MeNB shall implement a mechanism to prevent key stream reuse.

E.3.10 Protection of the traffic between the UE and SgNB

E.3.10.1 General

The ciphering protection shall be applied between the UE and gNB at the PDCP layer. The integrity protection shall be applied to the SRB between the UE and gNB at the PDCP layer.

The inputs to the integrity and ciphering algorithms are the same as the input for the algorithms in LTE. Both the UE and SgNB shall support the following algorithms described in Annex D of TS 33.501 [43].

NEA0 (which is the same as EEA0) for both RRC and UP confidentiality.

128-NEA1 (which is the same as 128-EEA1) for both RRC and UP confidentiality.

128-NEA2 (which is the same as 128-EEA2) for both RRC and UP confidentiality.

128-NIA1 (which is the same as 128-EIA1) for RRC integrity protection.

128-NIA2 (which is the same as 128-EIA2) for RRC integrity protection.

Both the UE and SgNB may support the following algorithms described in Annex D of TS 33.501 [43].

128-NEA3 (which is the same as 128-EEA3) for both RRC and UP confidentiality.

128-NIA3 (which is the same as 128-EIA3) for RRC integrity protection .

The UE and SgNB shall not use NIA0 (which is the same as EIA0) between the UE and SgNB.

NOTE 1: UP integrity algorithms are supported by 5G-CN capable UEs but are not used when the UEs are accessing EPC.

NOTE 2: The UP integrity protection is not activated in SgNB when connected to EPC. The UE that can only access the EPC, and the SgNB that is only connected to EPC does not need to support UP integrity algorithms.

E.3.10.2 Creating the mapped UE NR security capabilities

The MeNB that does not have the UE NR security capabilities shall create them as follow:

- Set the support of NEA0, 128-NEA1, 128-NEA2, 128-NEA3, 128-NIA1, 128-NIA2, 128-NIA3 to the same as EEA0, 128-EEA1, 128-EEA2, 128-EEA3, 128-EIA1, 128-EIA2, 128-EIA3 respectively; and
- Set the rest of the bits to 0.

This mapping of E-UTRAN security algorithms support to NR security algorithms support means that for the purposes of dual connectivity to SgNB, the UE shall have the same support for 128-NEA1 as 128-EEA1, 128-NEA2 as 128-EEA2, 128-NEA3 as 128-EEA3, 128-NIA1 as 128-EIA1, 128-NIA2 as 128-EIA2 and 128-NIA3 as 128-EIA3.

Annex F (informative): Isolated E-UTRAN Operation for Public Safety

F.1 General Description

Isolated E-UTRAN Operation for Public Safety (IOPS) provides the ability to maintain a level of communications for Public Safety users, via an IOPS-capable eNB (or set of connected IOPS-capable eNBs), following the loss of backhaul communications.

The Isolated E-UTRAN mode of operation is also applicable to the formation of a Nomadic EPS deployment, i.e. a deployment of one or more standalone IOPS-capable eNBs, creating a serving radio access network without backhaul communications and also providing local IP connectivity and services to Public Safety users in the absence of normal EPS infrastructure availability.

3GPP TS 22.346 [35] lists the general requirements for LTE networks in Isolated E-UTRAN Operation for Public Safety (IOPS). A description of the architectural concept of IOPS is given in informative Annex K of 3GPP TS 23.401 [2].

This annex provides security guidelines for the operation of Public Safety networks in the no backhaul (to Macro EPC) scenario using the Local EPC approach [2].

The Local EPC approach assumes that an IOPS network can comprise either:

- A Local EPC and a single isolated IOPS-capable eNB (or a deployable IOPS-capable eNB), which may be co-located or have connectivity to the Local EPC; or
- A Local EPC and two or more IOPS-capable eNBs (or deployable IOPS-capable eNBs), which have connectivity to a single Local EPC.

A Local EPC includes at least MME, SGW/PGW and HSS functionality.

The Public Safety network operator dedicates a PLMN identity to IOPS mode of operation which is broadcast in System Information by the eNB when IOPS mode is in operation. Only authorized IOPS-enabled UEs can access a PLMN indicated as an IOPS PLMN.

F.2 IOPS security solution

The security features and procedures described in this specification can be used to provide a security solution for an IOPS network based upon the Local EPC approach.

In order to ensure that support for IOPS does not compromise the security of normal operation, when operating in IOPS mode the AKA procedure (subclause 6.1 of this specification) is performed between a USIM application dedicated exclusively for IOPS operation on a UICC, present in IOPS-enabled UEs, and the Local HSS (contained in the Local EPC). The same applies in the event of a loss of backhaul communications and a transition of the IOPS-capable eNB to support Isolated E-UTRAN operation for a population of IOPS-enabled UEs.

The USIM application dedicated exclusively for IOPS operation uses a distinct set of security credentials separate from those used for 'normal' operation. These credentials are configured in the Local HSS and in the UICC prior to the commencement of IOPS operation.

The USIM application dedicated exclusively for IOPS operation, in an IOPS-enabled UE, has a distinct set of security credentials which contains at least:

- A permanent key K (uniquely assigned for IOPS operation).
- The PLMN identity assigned for IOPS network operation.
- An IMSI (uniquely assigned for IOPS operation).
- Access Class status of 11 or 15 (subject to regional/national regulatory requirements and operator policy).

These credentials are provisioned in all Local HSSs within the Local EPCs supporting IOPS operation where the Public Safety authority requires that the UE be provided service in the event of a loss of backhaul communication.

Storage of the IOPS network security credential set in the Local HSS is only performed for UEs authorised for operation in the IOPS network. Administrative provisioning is used to keep up to date security credentials for all authorised UEs at the Local HSSs within the Local EPCs. Updates are provided within a security context that already exists between the EPC and eNBs in the 'normal' network.

This solution provides integrity and confidentiality for IOPS networks and maintains commonality with the procedures defined in this specification. Furthermore, the approach is aligned with the implementation and deployment guidelines for IOPS as defined in 3GPP TS 23.401 [2].

F.3 Security Considerations

F.3.1 Malicious switching of USIM applications

The use of a distinct set of security credentials counteracts the possibility that malicious switching of USIM applications would permit unauthorised access to an IOPS network or to a normal PLMN. eNBs operating in IOPS mode and Local EPCs support Network Domain Control Plane protection (clause 11) and backhaul link user plane protection (clause 12) as appropriate.

F.3.2 Compromise of local HSSs

Subscriber credentials are provisioned in all Local HSSs within the Local EPCs supporting IOPS operation where the Public Safety authority requires that the UE be provided service in the event of a loss of backhaul communication. If one of these local HSSs was compromised by an attacker, either in the form that the attacker could obtain the subscriber credentials or that the attacker could control the interface to the local HSS, and if, for any given subscriber, the credentials in the local HSSs were the same, this would imply that, for all subscribers whose credentials were stored in the compromised local HSS, the USIMs out in the field would have to be swapped and the subscriber credentials would have to be re-provisioned in all local HSS.

The following subclause F.4 describes a mechanism, termed 'subscriber key separation' that would mitigate the effects of a compromise of a local HSS, as described in the preceding paragraph

NOTE 0: Void.

NOTE 1: Void

NOTE 2: Void.

F.4 Mitigation of compromise of a local HSS

F.4.0 Introduction

The text in the present subclause is informative as the described mechanism is completely transparent to MEs, eNBs, MMEs, and, for local HSSs, requires only configuration changes in the local Authentication Centres. The corresponding configuration capability is already available in AuCs today. The mechanism does require functional changes to UICCs, but not to the UICC-ME interface. As both UICC and local Authentication Centre are under the control of one operator, the configuration in the local Authentication Centre and the functional changes to UICCs can be implemented without any normative changes to existing 3GPP specifications. However, normative changes to UICC specifications are not precluded by the present text.

F.4.1 'Subscriber key separation' mechanism

Subscriber key handling:

For each subscriber, there is a subscriber master key MK for IOPS purposes. This master key MK is stored in the UICC, but not in any local HSS. Assume that there are N local HSSs, HSS_1, ..., HSS_N. As part of the provisioning process for local HSS_n ($1 \leq n \leq N$), a key K_n is derived from MK using a suitable representation of n as input, so that all K_n are different and the knowledge of K_n does neither allow inferring knowledge about MK nor about any K_m with m different from n. An example of a suitable key derivation function is given further below in subclause F.4.2. Each local HSS_n is then provisioned with the subscriber key K_n.

Identification of a local HSS:

A local HSS is identified by a number n between 1 and N. We assume here that $N < 256$. If this assumption does not hold then a grouping into subclasses is used, as described in the next subclause. The number n is represented by 8 bits, bit "0" to bit "7". The representation of n draws on the proprietary part of the Authentication Management Field (AMF), cf. Annex H of 3GPP TS 33.102 [4], in the following way:

Bits "0" to "7" of n: The IOPS operator chooses a subset of the proprietary bits "8" to "15" of the AMF to be used in order to address his N local HSSs, and then informs the UICC vendor of his choice of AMF bits. Bits that are not in this subset are set to zero in the representation of n. For a given local HSS, the IOPS operator selects a specific combination of the chosen AMF bits, which is the same for all subscribers, and maps them to the bit position k-8 in the representation of n when k is the position of the bit in the AMF. It needs to be ensured by agreement between local HSS vendor and UICC vendor (following operator requirements) that the AMF bits chosen for IOPS purposes are not used for any other purpose.

An example of the use of these AMF bits for IOPS purposes is as follows: Assume that there are 50 local HSSs (i.e. $N=50$) and the IOPS operator uses bit 10 of the AMF for a proprietary purpose. By way of example, bit "9" and bits "11" to "15" of the AMF are chosen for IOPS purposes, which would allow addressing 64 local HSSs.

Grouping into Subclasses:

Let us assume that the maximum number of local HSSs that can be uniquely addressed through the use of the selected AMF bits is L. (If all 8 bits are used, $L=256$). In case the number N of local HSSs is greater than or equal to L then the local HSSs can be grouped into M subclasses where $M < L$. In each subclass, the subscriber credential K_n would be the same for a given subscriber. In this way, the impact of a compromise of one local HSS would be limited to the local HSSs in one subclass, and only the local HSSs of this subclass would need to be reconfigured. I.e. this would greatly reduce the impact of a compromise from N local HSSs to N/M local HSSs. There would still be no need for exchanging the UICCs.

NOTE: If the available bits of the AMF are not sufficient to assign a unique ID to an IOPS operator's local HSSs, the representation of n may draw on an additional source: the IND part of the sequence number SQN, as described in Annex C.1 of TS 33.102. It is recommended to only draw on the bits in the AMF, and not use the IND part of the sequence number SQN, if the available AMF bits suffice to identify the local HSSs.

Authentication Procedure:

The run of an EPS AKA procedure in the presence of the subscriber key separation mechanism is identical to that without the presence of the mechanism, except for the operation of the USIM application on the UICC dedicated to IOPS. The modified operation is described as follows: whenever the UICC receives an AUTHENTICATE command from the ME that is destined towards the USIM dedicated to IOPS, the USIM dedicated to IOPS first checks the AMF bits chosen for IOPS purposes and determines whether the local HSS uses the subscriber key separation mechanism and, if so, what is the number n of the local HSS. The USIM dedicated to IOPS then proceeds to derive K_n from MK. The key K_n then takes the role of the permanent subscriber key K, and EPS AKA proceeds as described in the present specification and in 3GPP TS 31.102 [4], with K_n replacing K in all computations.

F.4.2 Key derivation mechanism for 'subscriber key separation'

The key derivation (including input parameter encoding) for deriving K_n from MK is performed using the key derivation function (KDF) specified in Annex A.17 of the present specification.

One of the input parameters f(n) to the KDF in Annex A.17 is obtained by applying a function f to n. The function f is realised as a table in the IOPS dedicated USIM. The parameter P0 in Annex A.17 corresponds to the value indexed by n in the table. The table in the USIM needs to be updated by OTA (Over-The-Air) means in case a local HSS is compromised, cf. clause F.5.

An example realisation of a function f could take the following form: $f(n) = n \parallel m$, where m is an 8-bit representation of a number between 0 and 255 and $n \parallel m$ is the concatenation of the bit representations of n and m . Initially, all m values are set to zero. When there is a need to update the table, due to a compromise of the local HSS with number n , then the value m for this n will be increased by 1. So, over time, the m -values for different n may differ. This table allows a UE to calculate the key K_n as the UE moves from one local HSS to another. If a local HSS is compromised, its keys cannot be updated until OTA communications with the macro-HSS are resumed. In that case, the UEs can be notified to update the relevant m value in their tables; the UEs can then re-calculate the new key for any compromised HSS without the necessity for OTA updates of the whole table. The circumstances in which the whole table is re-initialized will be determined by the individual operator.

NOTE: The advantage of using $f(n)$, instead of n directly, as input to the KDF is that n can be re-allocated after a compromise of a local HSS once the table has been updated. The update of the table would mean a modification of the value in the table that is indexed by n .

F.5 Actions in case of compromise of a local HSS

In case of a compromise of one local HSS, other local HSSs are not affected (because they have a different set of secrets and it is assumed that an attacker knowing K_n cannot use this information to retrieve the corresponding IOPS master subscriber key). Furthermore, there is no need for swapping all USIMs, only the compromised local HSS (or the local HSSs in the subclass sharing the same subscriber key, cf. NOTE above) needs to be newly provisioned with keys derived from the MK and a newly provisioned value in the table of the IOPS dedicated USIM.

Action can, of course, only be taken, after the compromise of a local HSS was detected. But even before detection of the compromise, the subscriber key separation mechanism ensures that the attacker can neither use the compromised key K_n to impersonate the subscriber towards another local IOPS network nor impersonate another local IOPS network towards the subscriber. Therefore, the mechanism is useful even before new provisioning has taken place. But the attacker can impersonate the local IOPS network towards the subscriber until revocation has taken place.

NOTE 1: Sequence number handling: One of the tasks of a USIM application is handling sequence numbers for the AKA protocol (cf. TS 33.401, which refers to TS 33.102 for this purpose). Often, an array is used as specified in TS 33.102, Annex C. The USIM dedicated exclusively for IOPS may use the same array for all keys K_n and increase a sequence number as if the authentication challenge came from a single HSS (instead of from several local HSSs as in the present use case). Protection against replay of challenges continues to be guaranteed as the USIM then records all sequence numbers sent by any of the local HSSs that have been successfully used.

NOTE 2: Re-synchronisation: When a UE moves from one local HSS to the next one, it could happen that the second local HSS generates authentication vectors with a sequence number that is too low as seen from the USIM with the added functions. This would then result in a re-synchronisation procedure that would be successful as the AUTS parameter in the re-synchronisation procedure causes the local HSS to update its sequence number and consequently generate an authentication vector that will be accepted by the USIM. This would then result in a successful Attach procedure, albeit at the expense of some added delay. If the delay is a concern and re-synchronisation procedures may be frequent due to frequent movements of UEs between local HSSs then this problem could be almost completely solved by using the IND value of the sequence number, cf. Annex C of 3GPP TS 33.102 [4], to distinguish among local HSSs, i.e. set up the local HSSs such that they use only particular IND.

Annex G (normative): LTE - WLAN aggregation

G.1 Introduction

This clause describes the security functions necessary to support an UE that is simultaneously connected to an eNB and a WT for LTE-WLAN Aggregation as described in TS 36.300 [30].

The LWA architecture is shown in Figure G.1-1.

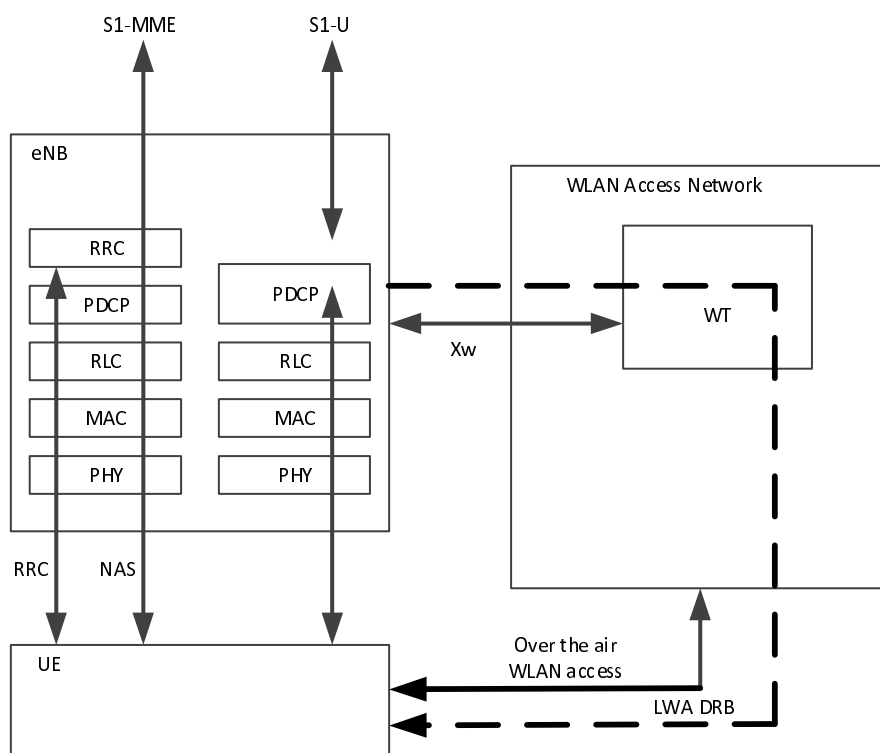

Figure G.1-1 LWA architecture

For LTE-WLAN Aggregation the end-points of encryption remain at the respective PDCP layers of the eNB and the UE, even though the PDCP packets traverse a different path via the WLAN Access Network. The WT is the termination point of the WLAN Access Network facing the eNB.

The UE-WT link needs to be secured to protect the PDCP and the WLAN signalling in the eNB from possible attacks.

Security requirements for this protection are given below.

- 1) The UE-WT link shall be integrity and confidentiality protected.
- 2) Xw interface: Control plane (Xw-C) and User plane (Xw-U) need to be integrity protected. User plane (Xw-U) encryption between eNB and WT may NOT be needed since PDCP packets are already encrypted.

Sub clauses below describe how these requirements are met.

G.2 LTE-WLAN aggregation security

G.2.1 Protection of the WLAN Link between the UE and the WT

The WLAN communication established between the WLAN AP and the UE shall be protected using the IEEE 802.11[39] security mechanisms. The security key for protecting the over the air WLAN link is computed from the current UE – eNB security context. Security protection within the WLAN network between WT and WLAN AP is out of scope for 3GPP.

When the eNB initially establishes LWA with the UE through a WT for a given AS security context shared between the MeNB and the UE, the eNB generates the $S-K_{WT}$ for the WT and sends it to the WT over the Xw. The same $S-K_{WT}$ is also generated by the UE.

To generate the $S-K_{WT}$, the eNB shall use a counter, called a WT Counter. The WT Counter shall be incremented for every new computation of the $S-K_{WT}$ as described in the clause G.2.4. The WT Counter is used as freshness input into $S-K_{WT}$ derivation as described in the clause G.2.4, and guarantees, together with the other provisions in the present clause G, that the same $S-K_{WT}$ is not re-used with the same input parameters as defined in Annex B of the present specification. The latter would result in key-stream re-use. The eNB shall send the value of the WT Counter to the UE over the RRC signalling path when it is required to generate a new $S-K_{WT}$.

To establish WLAN security, the UE and WT shall use the key $S-K_{WT}$ as equivalent to either the PMK or PSK defined in IEEE 802.11 specification.

To use $S-K_{WT}$ as PMK, the UE shall initialize the PMKSA described in [39] section 11.5.1.1.2 with PMKID set to Truncate-128(HMAC-SHA-256(PMK, "PMK Name" || AA || SPA)), where AA = WLAN AP MAC address and SPA = UE MAC address and start the 4-way handshake on the WLAN link between the UE and the WLAN AP by sending association request with PMKID Information Element included in the request. In case PMKID is not found at the WLAN AP (e.g, AP is not collocated with the WT or AP does not support receipt of $S-K_{WT}$ from WT and initialization of PMKSA), the AP may start EAP authentication by sending EAP Identity Request. A method for the UE and the WT to install PMK and initialize PMKSA from $S-K_{WT}$ at such a WLAN AP is described in clause G.3.

To use $S-K_{WT}$ as PSK, the WT should support PSK AKMs suites 2 and 6 described in [39] clause 9.4.2.25.3. The UE should use the PSK to start the 4-way handshake.

NOTE: The combination of UE WLAN MAC address and exposure of the IMSI in the same context could impact user privacy. It is left to the implementation to mitigate the UE privacy risk, subject to regional/national regulatory requirements.

G.2.2 Protection of the Xw interface

The control plane signalling between eNB and WT over the Xw interface, that includes the transfer of the $S-K_{WT}$ and the MAC address (i.e. the UE Identity as described in TS 36.463 [40]) used to identify the $S-K_{WT}$ in the the WT from the eNB to the WT, shall be confidentiality and integrity protected using security protection as described in clause 5.3.4a and clause 11 of the present specification. Any user plane data between eNB and WT over Xw interface shall be allowed only for authenticated UEs.

G.2.3 Addition, modification and release of DRBs in LWA

When executing the WT Addition procedure (i.e. the initial offload of one or more radio bearers to the WT), or the WT Modification procedure requiring an update of $S-K_{WT}$, the eNB shall derive an $S-K_{WT}$ as defined in clause G.2.4. The eNB shall forward the generated $S-K_{WT}$ to the WT during the WT Addition procedure or WT Modification procedure requiring key update. When offloading additional bearers to a WT after the initial offload, the $S-K_{WT}$ does not need to be refreshed.

NOTE: Refer to TS 36.300 [30] for definition of the LWA procedures.

The UE shall derive the $S-K_{WT}$ as described in clause G.2.4.

eNB releases the LWA through a WT Release procedure. Upon LWA Release Request message to WT and Release LWA Configuration message to UE from eNB, both UE and WT shall release the WLAN path and delete the S-K_{WT} key and the subsequent keys derived.

G.2.4 Derivation of keys for the DRBs in LWA

G.2.4.1 WT Counter maintenance

The eNB shall associate a 16-bit counter, WT Counter, with the EPS AS security context.

The WT Counter is used when computing the S-K_{WT}. The UE and the eNB shall treat the WT Counter as a fresh input to S-K_{WT} derivation. That is, the UE assumes that the eNB provides a fresh WT Counter for each S-K_{WT} derivation and does not need to verify the freshness of the WT Counter.

NOTE: The value of the WT Counter is integrity and replay protected when sent over the air in the RRC signaling, and so force re-use of the same WT Counter and computation of the same S-K_{WT} is prevented. The eNB maintains the value of the counter WT Counter for a duration of the current AS security context between UE and eNB. The UE does not need to maintain the WT Counter after it has computed the S-K_{WT} since the eNB provides the UE with the current WT Counter value when the UE needs to compute a new S-K_{WT}.

The eNB that supports the LWA DRB offload shall initialize the WT Counter to '0' when the K_{eNB} in the associated AS security context is established. The eNB shall set the WT Counter to '1' after the first calculated S-K_{WT}, and monotonically increment it for each additional calculated S-K_{WT}. The WT Counter value '0' is hence used to calculate the first S-K_{WT}.

If the eNB decides to turn off the LWA offload connection and later decides to re-start the offloading to the same WT, the WT Counter value shall keep increasing, thus keeping the computed S-K_{WT} fresh.

The eNB shall refresh the K_{eNB} of the AS security context associated with the WT Counter before the WT Counter wraps around. Re-freshing the K_{eNB} is done using intra cell handover procedure as described in clause 7.2.9.3 of the present specification. When this K_{eNB} is refreshed, the WT Counter is reset to '0' as defined above.

G.2.4.2 Security key derivation

The UE and eNB shall derive the security key S-K_{WT} of the target WT as defined in Annex A.18 of the present specification.

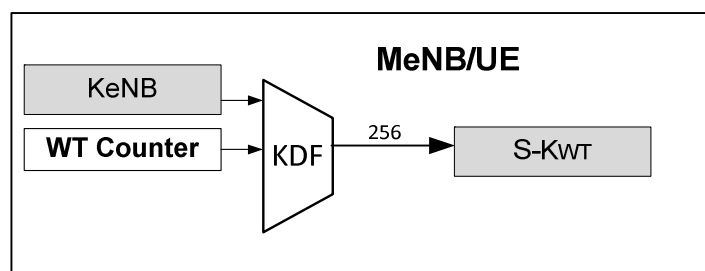

Figure G.2.4.2-1 S-K_{WT} computation

G.2.5 Security key update

G.2.5.1 Security key update triggers

The system supports update of the S-K_{WT}. The eNB may update the S-K_{WT} for any reason by using the S-K_{WT} update procedure defined in clause G.2. 5.2 of the current specification. If the eNB re-keys its currently active K_{eNB} in an AS security context, the eNB may update any S-K_{WT} associated with that AS security context.

G.2.5.2 Security key update procedures

If the eNB decides to perform S-K_{WT} update (see clause G.2.5.1), the eNB shall increment the WT Counter and compute a fresh S-K_{WT}, as defined in clause G.2.4. Then the eNB shall perform a WT Modification procedure to deliver the fresh S-K_{WT} to the WT. The eNB shall provide the value of the WT Counter used in the derivation of the S-K_{WT} to the UE in an integrity protected RRC message. The UE shall derive the S-K_{WT} as described in clause G.2.4.

The UE and WT shall start using a fresh S-K_{WT} when subsequent WLAN authentication is triggered. If there are multiple S-K_{WT} keys at the UE and the WT, the latest S-K_{WT} shall be used. Whenever the UE or WT start using a fresh S-K_{WT} as PMK they shall refresh the IEEE 802.11 security.

NOTE: In certain abnormal scenarios (e.g., the eNB detects there is mismatch in the PDCP Count when performing Counter Check procedure), the eNB can force the WLAN authentication of the UE by performing the WT Release procedure first and then the WT Addition procedure (see clause G.2.3).

G.2.6 Handover procedures

During S1 and X2 handover, when the LWA DRB connection between the UE and the WT is released, the UE shall delete the S-K_{WT} and further keys derived based on it.

During or after handover where the LWA configuration is retained through the same WT as explained in clause 10.1.2.2 of TS 36.300[30], the UE may keep two sets of PDCP keys corresponding to the old PDCP and new PDCP, until an end marker packet is received from the source eNB.

After the UE receives the "end-marker packet", any received PDCP PDUs whose COUNT value is larger than the COUNT value corresponding to the Sequence Number in the "end-marker packet" shall be discarded.

G.2.7 Periodic local authentication procedure

The eNB terminates the PDCP for control plane and user plane for the UE. Hence, the periodic local authentication procedure can be performed between UE and eNB as described in clause 7.5 also for the case the PDCP packets that traverse the WLAN link.

G.2.8 LTE and WLAN link failure

Connectivity can fail on the WLAN side as well as on the LTE side. In both cases, when WLAN or LTE link failure is discovered, the UE shall delete the S-K_{WT}, the eNB shall indicate to the WT to delete the S-K_{WT}.

G.3 Method for installing PMK

An existing IEEE 802.1x compliant AP may not support receiving S-K_{WT} from WT and using it as the PMK. In order to support LWA with existing WLAN deployments with such APs, the UE and the WT may leverage the existing EAP authentication procedures at the AP to install PMK and create PMKSA. A 3GPP vendor specific EAP authentication method for LWA, herein after referred to as EAP-LWA, is described in this clause.

NOTE: In order to use EAP-LWA as a vendor specific EAP method, the existing 3GPP Vendor-Id of 10415 registered with IANA under the SMI Private Enterprise Code registry is used. The Vendor-Type ID is specified in Annex C of TS 33.402 [41].

In this method, the WT maintains an association of the current UEs instructed to use LWA offloading by an eNB, and the assigned S-K_{WT} for that UE. A new UE identity called the LWA-ID is used to identify the UE to the WT and is derived as shown in step 3 of figure G.1-1 and is known by the UE and WT. If the WLAN AP does not have the PMK (S-K_{WT}), upon receipt of EAP-Identity Request message from the WLAN AP, the UE sends an EAP-Identity Response message to the AP with an NAI with realm portion including the identifier of the WT where the S-K_{WT} can be found and the LWA-ID as the user portion of the NAI. The AP routes the EAP-Identity Response message to the WT identified by the realm. Upon receipt and successful identification of the UE, the WT initiates EAP-Request Challenge to the UE to perform successful EAP authentication between the UE and WLAN AP and the installation of the PMK at the WLAN AP.

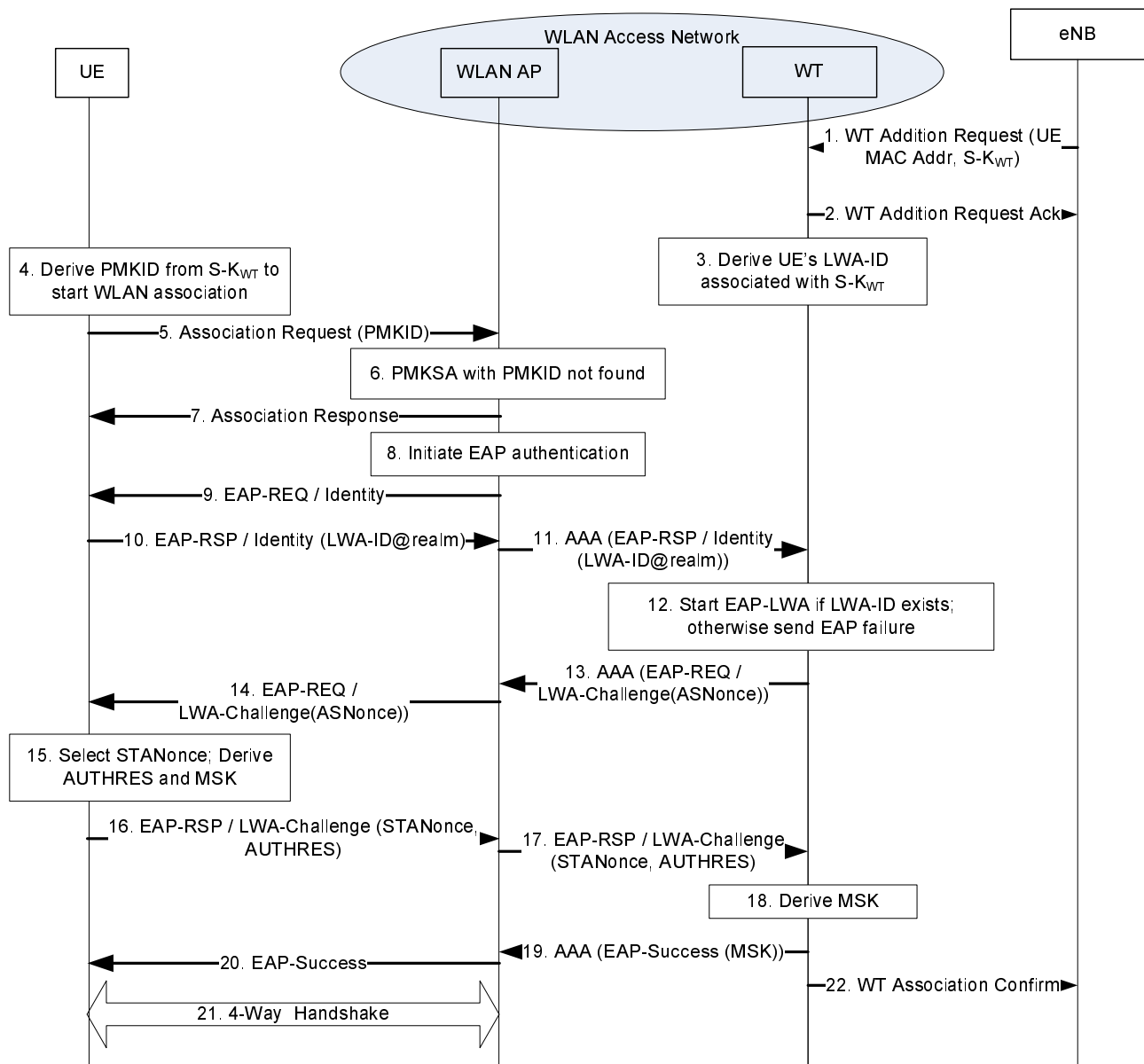

Figure G.1-1: 3GPP vendor specific EAP-LWA method

- 1) When eNB wants to start LWA for the UE, it sends WT Addition Request to the WT. This request includes the UE MAC address and the $S-K_{WT}$.
- 2) WT acknowledges the receipt of WT Addition request.
- 3) WT sets LWA-ID to $\text{SHA256}(S-K_{WT}, \text{UE MAC addr}, \text{"LWA Identity"})$ and associates with the received $S-K_{WT}$.
- 4) After receiving command from eNB to start LWA and deriving $S-K_{WT}$, the UE derives PMKID as specified in clause G.2.1.
- 5) UE includes the PMKID in the WLAN Association Request.
- 6) The PMKSA associated with PMKID is not found at the WLAN AP.
- 7) The WLAN AP responds with WLAN Association Response, omitting the PMKID that is not found at the AP.
- 8) WLAN AP initiates EAP authentication.
- 9) WLAN AP sends EAP-Identity Request message.

- 10) The UE responds with EAP-Identity Response message with the LWA-ID@realm as the UE identity for EAP-LWA. The LWA-ID and realm are set as follows:

LWA-ID = SHA256 (S-K_{WT}, UE MAC addr, "LWA Identity");

realm = lwa.wtid<WTID>.mnc<MNC>.mcc<MCC>.3gppnetwork.org;

WTID = E-UTRAN Cell Identity (ECI) of eNB;

MNC = MNC of Serving Network PLMN Identity;

MCC = MCC of Serving Network PLMN Identity.

- 11) WLAN AP uses the realm and routes the EAP-Identity response to WT as AAA message.
- 12) WT uses LWA-ID to locate the S-K_{WT}. If LWA-ID is not found, the WT sends EAP-Failure message, terminating the WLAN association.
- 13) WT initiates EAP-LWA, by sending AAA EAP-Request/LWA-Challenge message, by including a 128-bit random nonce, ASNonce.
- 14) AP forwards the EAP-Request/LWA-Challenge message to the UE.
- 15) UE selects a 128-bit random nonce, STANonce, and derives AUTHRES and MSK as follows:
- AUTHRES = SHA256 (S-K_{WT}, ASNonce, STANonce, "LWA AUTHRES");
- MSK = SHA256 (S-K_{WT}, ASNonce, STANonce, "LWA MSK Key Derivation").
- 16) UE sends EAP-Response/LWA-Challenge message with STANonce and AUTHRES.
- 17) WLAN AP forwards the EAP-Response/LWA-Challenge AAA message to WT.
- 18) WT derives AUTHRES and MSK as specified in step 15) and compares it with the received AUTHRES. If they are same, EAP-LWA authentication is successful, and proceeds to step 19). Otherwise EAP-Failure message is sent, terminating WLAN association procedure.
- 19) WT sends EAP-Success with MSK as AAA message to WLAN AP.
- 20) WLAN AP sends EAP-Success.
- 21) Upon receiving EAP-Success, the UE and WLAN AP perform 4-way handshake and complete WLAN association.
- 22) WT sends WT Association Confirm message to the eNB, confirming successful WLAN association of the UE. Note that WT may send this message anytime after step 19).

Annex H (normative): LTE-WLAN RAN level integration using IPsec tunnelling

H.1 General

This clause describes the security functions necessary to support LTE-WLAN integration using IPsec tunnelling as described in TS 36.300 [30].

The LTE-WLAN integration architecture is shown in Figure H.1-1 and the protocol stack in Figure H.1-2.

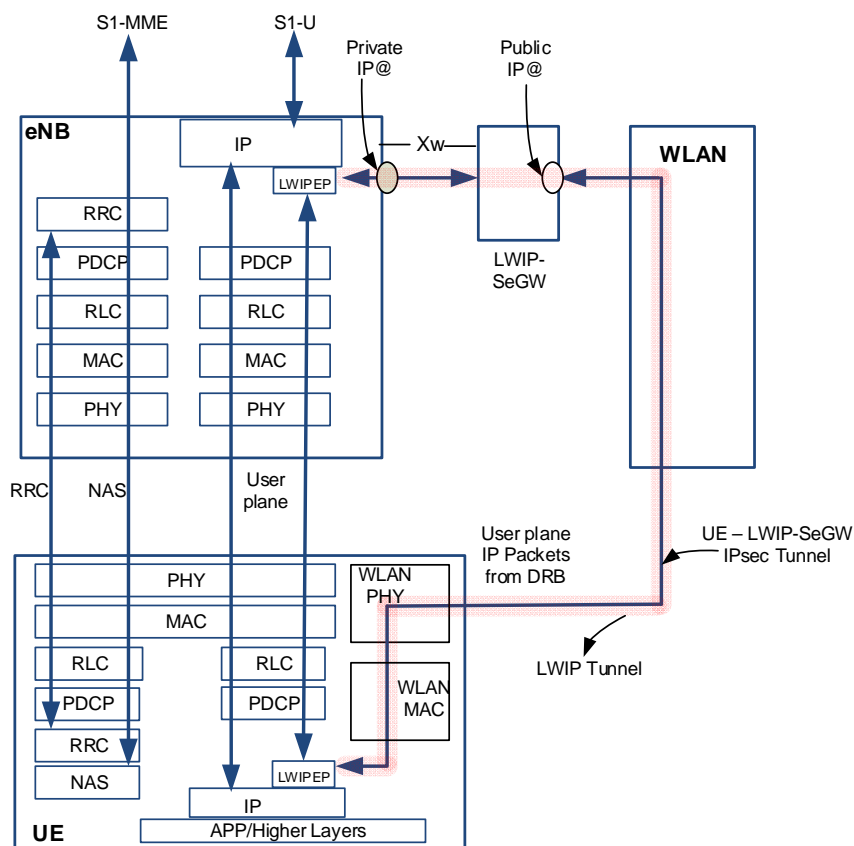

Figure H.1-1 LTE-WLAN integration architecture using IPsec tunnelling

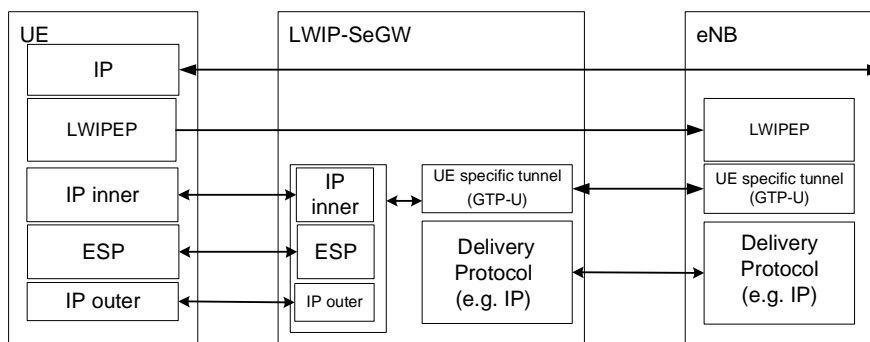

Figure H.1-2 LTE-WLAN integration using IPsec tunnelling protocol stack

For LTE-WLAN integration using IPsec tunnelling the integration happens using PDCP SDUs above the PDCP layer. The eNB controls activation of the integration based on the UE connectivity with a specific WLAN. Once the integration is activated, the eNB segregates incoming DL packets towards the UE for offloading via the WLAN at a layer above PDCP. The UL packets from the UE are aggregated by the eNB at the same logical point.

Since PDCP security is bypassed for the data routed through the WLAN and security of the legacy WLAN is not assumed, security for the PDCP SDUs and protection of the operator network shall be achieved in the following way:

- A LWIP-SeGW shall be placed between the eNB and the WLAN network for security of packets that traverse WLAN and to protect the Operator's network.
- The interface between the eNB and the LWIP-SeGW shall be confidentiality and integrity protected by NDS/IP TS 33.210 [36].
- An UE-specific IPsec security association tunnel shall be established between the UE and the public IP port of the LWIP-SeGW in tunnel mode.
- In addition to terminating IPsec from the UE, the LWIP-SeGW shall perform rate limitation for DoS protection on the eNB and its backhaul links.
- UEs, including authenticated and authorized UEs using LWIP, shall not have IP connectivity to the eNB.
- IP headers created by the UE in LTE WLAN integration using IPsec tunnelling shall not be parsed by the eNB.

NOTE 1: Void.

- The UE and the LWIP-SeGW function shall perform mutual authentication in the phase 2 of the IKEv2 handshake during the IPsec tunnel establishment, using the authentication key derived from the current AS security association.
- The LWIP-SeGW shall enforce binding of an authenticated UE to its IP address, and apply anti-spoofing measures on received packets for the UE's outer and inner IP source address(es).
- The LWIP-SeGW shall ensure that uplink traffic sent by a UE is only sent towards the correct eNB by conveying the traffic to a GTP-U tunnel over Xw.

NOTE 2: Void.

In addition, before the IPsec tunnel is established between the UE and the LWIP-SeGW, and before the offload can be performed, the UE needs to obtain IP connectivity across the WLAN network, which may require an access authentication independent of the EPC authentication, and is outside the scope of this specification.

H.2 Security of LTE-WLAN integration using IPsec Tunnelling

H.2.1 eNB to UE interaction for setting up the LWIP offload

When the eNB initially establishes LWIP with the UE, the eNB and the UE shall generate the LWIP security key, LWIP-PSK, as specified in clause H.4, to be used as the PSK for the IPsec tunnel set up between the UE and the LWIP-SeGW, as described in clause H.2.2.

The eNB shall provide to the UE, over the secure RRC signalling, the following parameters:

- IP address of the LWIP-SeGW for the IKEv2 handshake,
- The Initiator Identity value, IDi, that the UE shall use in the IKEv2 handshake.
- LWIP counter that the UE shall use in LWIP-PSK derivation.

H.2.2 UE to LWIP-SeGW interaction for setting up the LWIP offload

LTE-WLAN integration (LWIP) over legacy WLAN is secured using an IPsec in a tunnel mode established between the UE, via the WLAN, and the LWIP-SeGW function. The IPsec in tunnel mode is established using the IKEv2 handshake based on the pre-shared key, PSK as specified in IETF RFC 7296 [38]. The UE and LWIP-SeGW shall use the LWIP-PSK as the PSK for authentication in the second phase of IKEv2.

In the IPsec tunnel between the UE and the LWIP-SeGW, the inner IP addresses shall be identical to the outer IP addresses. I.e., in UL the source IP address shall be the IP address of the UE in the WLAN network and the destination IP address shall be the public IP address of the SeGW, and in DL the source IP address shall be the public IP address of the SeGW and the destination IP address shall be the IP address of the UE in the WLAN network.

NOTE1: Void.

If the UE is located behind a NAT, the following will hold for the IPsec tunnel between the UE and the LWIP-SeGW:

- In UL between the UE and the NAT, the source IP address will be the local address of the UE in the WLAN.
- In DL between the LWIP-SeGW and the NAT, the destination IP address will be the public IP address under which the UE located behind the NAT is reachable.
- The NAT will then overwrite the address of the UE in the outer IP header during transport.

When conducting the IKEv2 handshake, the UE shall use the value of IDi and the IP address of the LWIP-SeGW received from the eNB.

The LWIP-SeGW shall use the received value of IDi to locate the corresponding LWIP-PSK.

NOTE2: To improve the DoS protection of the public IP port of the LWIP-SeGW, the LWIP-SeGW function can expect initiation of the IKEv2 handshake from the UE for a limited time window, based on a configuration. After expiration of this window, the LWIP-SeGW function can delete the LWIP-PSK and associated IDi, and rejects any IKEv2 handshake initiations.

After successful completion of the IKEv2 handshake, the LWIP-SeGW and the UE shall store the LWIP-PSK. When the IKEv2 SA is deleted, the LWIP-SeGW and the UE shall delete the LWIP-PSK.

For LWIP offloaded traffic, the eNB shall only be reachable through the LWIP-SeGW.

The LWIP-SeGW shall allow communication of the UE only to the eNB that initiated the LWIP offload, and only to the interface on this eNB allowed for the LWIP offload.

The profiles for IKEv2 and IPsec ESP as defined in TS 33.210 [36] shall be used.

H.2.3 eNB to LWIP-SeGW interaction for setting the LWIP offload

The PDCP SDUs between the eNB and LWIP SeGW shall be encapsulated in a tunnelling protocol as specified in TS 36.300 [30] in order to avoid that the eNB needs to interpret IP packets coming from the UE.

The eNB shall inform the LWIP-SeGW function of the expected initiation of IKEv2 handshake by a UE, for subsequent establishment of the IPsec, and provide the following parameters:

- the Initiator ID value, (IDi) that the UE will use in the IKEv2 handshake,
- the LWIP-PSK.

The standardized Xw interface between the eNB and the LWIP-SeGW is specified in TS 36.300 [30] and it shall be confidentiality and integrity protected by NDS/IP TS 33.210 [36].

H.3 Addition and modification of DRB in LTE-WLAN integration

All DRBs associated with the same UE and routed through WLAN shall use the same IPsec tunnel established between the UE and the LWIP-SeGW function. The eNB manages the DRB addition and deletion as specified in TS 36.300 [30]. When the last DRB between the eNB and UE is deleted, the eNB shall instruct the LWIP-SeGW and the UE to release the IPsec tunnel.

H.4 Security Key for IKEv2 handshake

H.4.0 LWIP counter maintenance

The eNB shall associate a 16-bit counter, LWIP counter, with the EPS AS security context.

The LWIP counter is used when computing the LWIP-PSK for the IPsec tunnel set up. The UE and the eNB shall treat the LWIP counter as a fresh input to LWIP-PSK derivation. That is, the UE assumes that the eNB provides a fresh LWIP counter for each LWIP-PSK derivation and does not need to verify the freshness of the LWIP counter.

The eNB maintains the value of the LWIP counter for a duration of the current AS security context between UE and eNB. The UE does not need to maintain the LWIP counter after it has computed the LWIP-PSK since the eNB provides the UE with the current LWIP counter value when the UE needs to compute a new LWIP-PSK.

The eNB that supports the LWIP shall initialize the LWIP counter to '0' when the K_{eNB} in the associated AS security context is established or refreshed. The eNB shall monotonically increment the LWIP counter for each subsequent calculation of the LWIP-PSK.

If the eNB decides to turn off the LWIP and instruct the termination of the IPsec tunnel and later decides to re-start the LWIP using IPsec tunnel without updating the K_{eNB} , the LWIP counter value shall keep increasing, thus keeping the computed LWIP-PSK fresh.

The eNB shall refresh the K_{eNB} of the AS security context associated with the LWIP counter before the LWIP counter wraps around. Re-freshing the K_{eNB} is done using intra cell handover procedure as described in clause 7.2.9.3 of the present specification.

H.4.1 Security Key (LWIP-PSK) Derivation

The UE and eNB shall derive the security key LWIP-PSK for the IPsec tunnel set up as shown on the Fig.H.4.1-1 and defined in Annex A.16 of the present document.

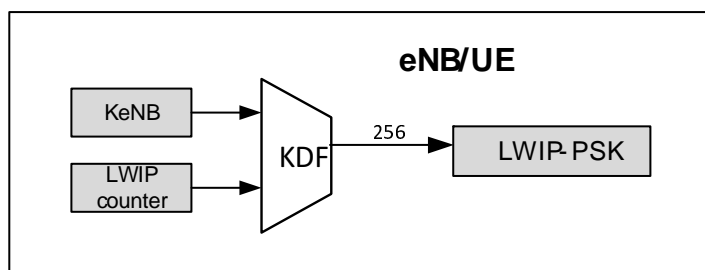

Fig.H.4.1-1: LWIP-PSK Derivation.

H.4.2 Security key (LWIP-PSK) update

The eNB may update the LWIP-PSK for any reason by releasing the IPsec tunnel and restarting it in the following way . The eNB shall instruct the LWIP-SeGW function to release the current IPsec tunnel, and provide a new LWIP-PSK to

support establishment of the new IPsec tunnel. The eNB shall instruct the UE over the RRC signaling to re-initiate the IKEv2 using the new LWIP-PSK to establish a new IPsec tunnel.

H.5 Handover procedures

During S1 and X2 handover, the IPsec tunnel between the UE and the LWIP-SeGW shall be released. The eNB shall instruct the LWIP-SeGW and the UE to release the IPsec. Both the LWIP-SeGW and the UE shall delete the LWIP-PSK.

H.6 LWIP radio link failure

When a LTE radio link failure is detected, the IPsec tunnel between the UE and the LWIP SeGW shall be released, either by the eNB informing the LWIP-SeGW of this event, or at the UE. Both the LWIP-SeGW and the UE shall delete the LWIP-PSK.

If the IPsec tunnel between the UE and the LWIP-SeGW is released due to WLAN connectivity issues, a fresh LWIP IPsec tunnel set up may be performed when WLAN wireless connectivity is restored.

Annex I (normative): Hash functions

I.1 General

This Annex describes how to form the inputs of non-keyed hash calculations using the KDF described in TS 33.220 [8].

I.2 HASH_{MME} and HASH_{UE}

When the MME and UE shall derive HASH_{MME} and HASH_{UE} respectively using the following parameters as input to the KDF given in TS 33.220 [8].

- S = Unprotected ATTACH Request or TAU Request message,

NOTE: The order of packing the input, S , to hash algorithm is the same as the order of packing the UL NAS message to the MME.

- Key = 256-bit string of all 0s

HASH_{MME} or HASH_{UE} are the 64 least significant bits of the 256 bits of the KDF output.

I.3 Void

Annex J (normative): Restricted Local Operator Services (RLOS)

J.1 Restricted Local Operator Services (RLOS)

J.1.1 General

Restricted Local Operator Services (RLOS) is an optional feature supported in certain countries and is specified in TS 23.401 [2]. RLOS is always initiated by the UE based on explicit request from the user. Access to RLOS may be allowed for UEs in limited service state by the serving network depending on local regulation and operator policy. Allowing access to RLOS for UEs in limited service state means that there is no network authentication and in such a case further security checks need to be performed by the UE to address the potential security threats due to this lack of network authentication (i.e., EPS AKA).

This Annex is not applicable for UEs accessing RLOS after performing successful EPS AKA authentication as they follow the security procedures specified in the main body of this specification.

J.1.2 Algorithm negotiation for unauthenticated UEs in LSM

UEs that are in limited service mode (LSM) and that cannot be authenticated by the MME (for whatever reason) may still be allowed to establish RLOS calls by sending the RLOS attach request message as specified in TS 23.401 [2].

It shall be possible to configure the MME to allow unauthenticated UEs in LSM to establish bearers for RLOS calls or not. If an MME is configured to allow unauthenticated UEs in LSM to establish bearers for an RLOS call, the MME shall for the NAS protocol use EIA0 and EEA0 as the integrity and ciphering algorithm respectively.

If the MME allows an unauthenticated UE in LSM to establish bearers for RLOS calls after it has received the RLOS attach request message from the UE, the MME shall:

- Select EIA0 and EEA0, regardless of the supported algorithms announced previously by the UE as the NAS algorithms and signal this to the UE via the NAS security mode command procedure when activating the EPS NAS security context.
- Set the UE EPS security capabilities to only contain EIA0 and EEA0 when sending these to the eNB in the following messages:
 - S1 UE INITIAL CONTEXT SETUP
 - S1 UE CONTEXT MODIFICATION REQUEST
 - S1 HANDOVER REQUEST

NOTE 1: The result of the MME only sending a UE EPS security capability containing EIA0 and EEA0 to the eNB is that the eNB is only capable of selecting EIA0 for AS integrity protection and EEA0 for AS confidentiality protection. That is, if EIA0 is used for NAS integrity protection, then EIA0 will always be used for AS integrity protection.

If the UE has initiated an RLOS connection, the UE may accept the use of EIA0 for NAS and RRC signalling protection. The UE shall also support the mitigations given in clause J.1.3 to reduce the impact of a lack of network authentication for RLOS connections.

J.1.3 Additional UE behaviour for RLOS connections

If the UE is in LSM and wishes to initiate an RLOS connection, the ME shall perform the following checks before initiating the RLOS attach procedure with the network:

- 1) The ME shall enforce access control on applications that are authorized to trigger establishment of RLOS connection. Applications on the ME that are not explicitly authorized shall not be allowed to trigger the initiation of RLOS connection.

- 2) A user confirmation shall be requested before the ME initiates RLOS connection. As part of the user confirmation, the user shall be notified of the security risk due to the lack of network authentication.
- 3) The ME shall maintain a white list of MCCs where RLOS is supported (i.e., by preconfiguring the white list either at the time of ME manufacturing or hardcoding). The ME shall check that the MCC of the network name that advertises RLOS service is present in the white list before initiating the RLOS connection.
- 4) If a USIM is present, the ME shall check that the MCC part of the IMSI configured in the USIM is present in the white list of MCCs on the ME before initiating the RLOS connection.

If the above checks are successful, the ME shall initiate the RLOS attach procedure. If any one of the above checks fail, then the ME shall not initiate the RLOS attach procedure.

J.2 Recommendations for RLOS

Allowing RLOS connections to the network for UEs that are in LSM means that there is no network authentication. This means that it is not possible to protect the NAS and AS traffic. RLOS services should be protected by implementing application layer security mechanisms. Such application layer security mechanisms are dependent on the RLOS service and are outside the scope of this document.

J.3 MCC whitelist for RLOS

The whitelist for RLOS shall be: MCC = 310, MCC = 311, MCC= 312, MCC=313, MCC=314, MCC=315 and MCC = 316.

Annex K (normative): Security for Integrated Access and Backhaul (IAB) in EN-DC

K.1 General

This Annex provides the security procedures applied to IAB-node when connecting to EPC. The IAB reference architecture, when connected to EPC, is defined in TS 23.401 [2].

IAB-node consists of a gNB-DU function and a UE function (referred to as IAB-UE). The IAB-UE function reuses UE procedures defined in this document to connect to EPC.

In an IAB (Integrated Access and Backhaul) architecture, the IAB-node can access the network using either standalone mode or EN-DC mode. Overall description of IAB feature in standalone mode is in 3GPP TS 38.300 [44]. The EN-DC specific details are defined in 3GPP TS 36.331 [21], TS 36.413 [42], and TS 36.423 [45].

When using the EN-DC mode, as shown in Figure K.1-1, the IAB-node connects via E-UTRA to a MeNB, and the IAB-donor terminates X2-C as SgNB.

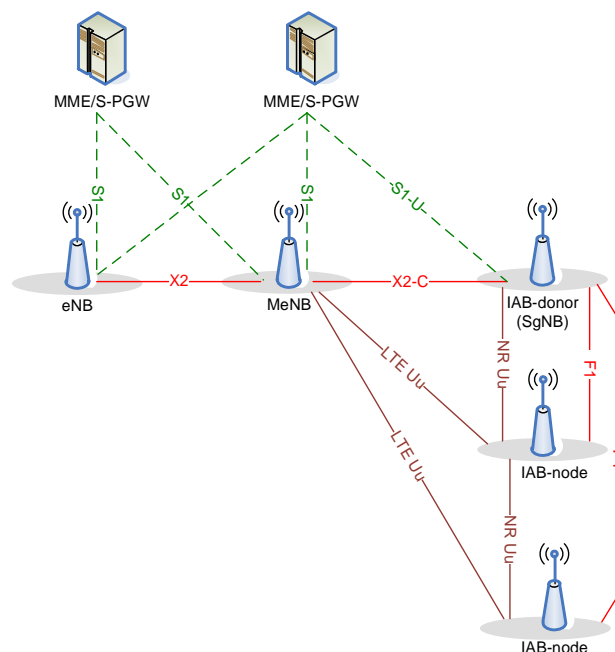

Figure K.1-1: IAB architecture when IAB-node is using EN-DC

The present document only deals with security aspects of IAB in the EN-DC mode. The security aspects of IAB in standalone mode (including authentication and authorization of IAB-nodes, and security of F1 interfaces) are defined in 3GPP TS 33.501 [43].

K.2 IAB-node integration procedure

K.2.1 Authentication and Authorization of IAB-node

The IAB-UE function shall behave as a UE, and shall reuse the UE procedures specified in this specification, when connecting to EPC, for the authentication, key derivation and distribution scheme, subscription credential(s) storage requirements, NAS security and AS security.

Authorization of IAB-nodes shall be performed by the EPC supporting IAB architecture as described in TS 23.401 [2].

A summary of Authentication and Authorization of IAB-node is illustrated in Figure K.2-1.

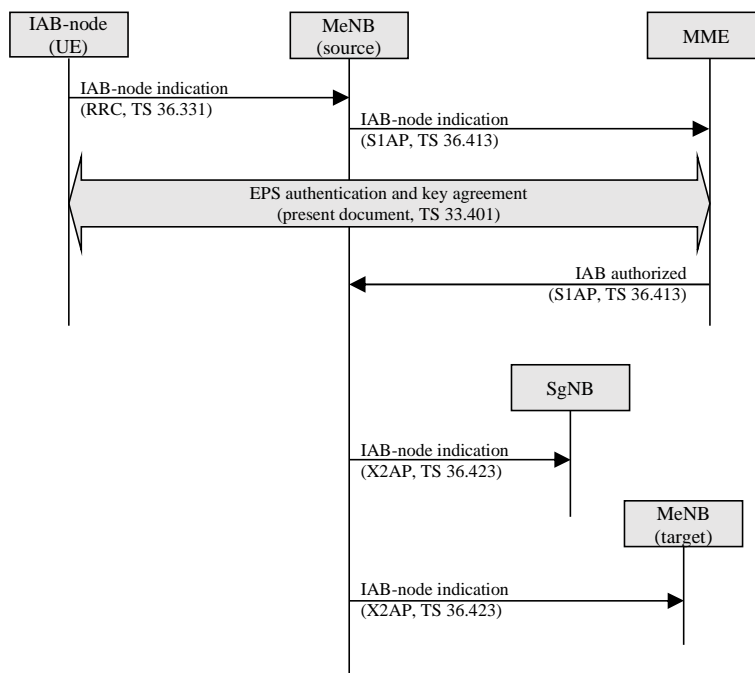

Figure K.2-1: Summary of authentication and authorization of IAB-nodes

- The indication of being an IAB-node is signalled from the IAB-node to the eNB as defined in 3GPP TS 36.331 [21].
- This indication is signalled from the eNB to the MME as defined in 3GPP TS 36.413 [42].
- Mutual authentication between the IAB-node and the EPC supporting the IAB architecture shall be performed using the authentication and key agreement procedure defined in the clause 6.1 of the present document.
- After successful authentication and validity check, the indication that the IAB-node is authorized is signalled from the MME to the eNB as defined in 3GPP TS 36.413 [42].
- During EN-DC procedures, the indication of IAB-node is signalled from the MeNB to the SgNB as defined in 3GPP TS 36.423 [45].
- During handover procedures, the indication of IAB-node is signalled from the one eNB to another eNB as defined in 3GPP TS 36.423 [45].

Annex L (informative): Security Aspects of DNS and ICMP

L.1 General

The security measures specified in Annex P of TS 33.501 [43] can be used to protect the DNS and ICMP messages that are carried over the user plane.

Annex M (normative): Protection of management traffic between IAB-node and OAM

If management traffic uses the user plane via PDN session, it shall be protected using the user plane security mechanism as specified in the present document.

Annex N (informative): Change history

Change history							
Date	TSG #	TSG Doc.	CR	Rev	Subject/Comment	Old	New
2009-09	SA#45	SP-090518	261	-	Editorial correction to Algorithms for Emergency Call	9.0.0	9.1.0
2009-09	SA#45	SP-090636	269	-	UE Security Capability Storage Clarification	9.0.0	9.1.0
2009-09	SA#45	SP-090636	277	-	Clarification of key change on the fly (Rel-9)	9.0.0	9.1.0
2009-09	SA#45	SP-090636	279	-	KeNB handling at RRC connection re-establishment (Rel-9)	9.0.0	9.1.0
2009-09	SA#45	SP-090518	281	-	XRES corrected to RES	9.0.0	9.1.0
2009-09	SA#45	SP-090636	301	1	Some corrections to the key hierarchy diagrams (Rel-9)	9.0.0	9.1.0
2009-09	SA#45	SP-090636	287	1	Correcting the details of NAS COUNT (Rel-9)	9.0.0	9.1.0
2009-09	SA#45	SP-090636	285	1	Correcting the setting of the key identifier to '111' (Rel-9)	9.0.0	9.1.0
2009-09	SA#45	SP-090636	283	1	Completing the EPS AKA description (Rel-9)	9.0.0	9.1.0
2009-09	SA#45	SP-090636	361	1	Clarification for Kenb and NH derivations definition	9.0.0	9.1.0
2009-09	SA#45	SP-090636	304	-	Clarification to EIA2 Test Vectors	9.0.0	9.1.0
2009-09	SA#45	SP-090636	306	-	Correction of rules on concurrent runs of security procedures	9.0.0	9.1.0
2009-09	SA#45	SP-090636	360	1	Miscellaneous Modifications	9.0.0	9.1.0
2009-09	SA#45	SP-090636	275	1	Clarification of NH usage (Rel-9)	9.0.0	9.1.0
2009-09	SA#45	SP-090636	289	1	Add missing details for NAS SMC (Rel-9)	9.0.0	9.1.0
2009-09	SA#45	SP-090636	297	1	Deleting mis-leading sentence in 7.2.9.2 (Rel-9)	9.0.0	9.1.0
2009-09	SA#45	SP-090636	299	1	Correction to key identification (Rel-9)	9.0.0	9.1.0
2009-09	SA#45	SP-090636	291	1	Clarifying the inter-RAT TAU Request behaviour (Rel-9)	9.0.0	9.1.0
2009-09	SA#45	SP-090636	293	1	Correcting the calculation of K_eNB at handover to E-UTRAN (Rel-8)	9.0.0	9.1.0
2009-09	SA#45	SP-090518	305	2	Clarification for the Clauses 5.1.4.1 and 5.1.4.2 of the Rel-9 TS 33.401	9.0.0	9.1.0
2009-09	SA#45	SP-090518	280	1	EPS NAS security context handling in UE at EC when NULL algorithms are established	9.0.0	9.1.0
2009-09	SA#45	SP-090518	260	2	Correction to Emergency Call Optimization Procedure	9.0.0	9.1.0
2009-09	SA#45	SP-090636	271	1	Corrections of security context	9.0.0	9.1.0
2009-12	SA#46	SP-090811	310	1	selected algorithms forwarding to the target eNB in intra LTE handover	9.1.0	9.2.0
2009-12	SA#46	SP-090812	311	-	Clarification of Current security context	9.1.0	9.2.0
2009-12	SA#46	SP-090812	313	2	Security interworking between E-UTRAN and GERAN in 128-bit encryption	9.1.0	9.2.0
2009-12	SA#46	SP-090811	316	1	Correction of protection of the NAS security mode reject message (Rel-9)	9.1.0	9.2.0
2009-12	SA#46	SP-090811	318	2	EPS NAS security context storage	9.1.0	9.2.0
2009-12	SA#46	SP-090812	321	-	Clarification of confidentiality protection in EC	9.1.0	9.2.0
2009-12	SA#46	SP-090812	322	2	Authentication failure during emergency call	9.1.0	9.2.0
2009-12	SA#46	SP-090811	324	3	Correction of ECM states	9.1.0	9.2.0
2009-12	SA#46	SP-090811	326	1	Clarifications to context handling in idle mode procedures	9.1.0	9.2.0
2009-12	SA#46	SP-090812	328	1	Clarifications to context handling in IRAT handover	9.1.0	9.2.0
2009-12	SA#46	SP-090811	330	1	Correction to store security context to ME	9.1.0	9.2.0
2009-12	SA#46	SP-090811	332	1	Corrections to state transition	9.1.0	9.2.0

2009-12	SA#46	SP-090812	334	-	Clarification for algorithm selection during IRAT handover to EUTRAN	9.1.0	9.2.0
2009-12	SA#46	SP-090811	336	-	Corrections for 33.401	9.1.0	9.2.0
2009-12	SA#46	SP-090811	338	1	Concurrency of inter-MME handovers and NAS downlink messages (Rel-9)	9.1.0	9.2.0
2009-12	SA#46	SP-090812	340	-	Partial native EPS security context NAS COUNT value	9.1.0	9.2.0
2009-12	SA#46	SP-090811	343	1	Clarification of NAS integrity protection activation	9.1.0	9.2.0
2009-12	SA#46	SP-090811	348	2	Nas-token and key calculation at idle mobility from E-UTRAN to UTRAN/GERAN (Rel-9)	9.1.0	9.2.0
2009-12	SA#46	SP-090811	352	-	Clarifying the calculation of KeNB when there is more than one NAS SMC (Rel-9)	9.1.0	9.2.0
2009-12	SA#46	SP-090811	354	3	Behaviour for lost NAS SMC message when creating mapped context (Rel-9)	9.1.0	9.2.0
2009-12	SA#46	SP-090812	356	4	Clarification of Authentication Data and transition to EMM-DEREGISTERED and Correction of text on authentication data transfer	9.1.0	9.2.0
2009-12	SA#46	SP-090811	359	-	NCC Initialization in eNB at the Initial Connection Setup	9.1.0	9.2.0
2009-12	SA#46	SP-090811	360	1	key replacement clarification	9.1.0	9.2.0
2009-12	SA#46	SP-090811	362	1	Replacing KDF definition with a reference	9.1.0	9.2.0
2009-12	SA#46	SP-090812	364	1	Correction of interworking between GERAN and E-UTRAN	9.1.0	9.2.0
2009-12	SA#46	SP-090811	366	-	Correcting A.11	9.1.0	9.2.0
2009-12	SA#46	SP-090811	367	1	Not resetting STARTPS to 0 in HO from EUTRAN to UTRAN and not resetting STARTCS to 0 in SRVCC (Rel-9).	9.1.0	9.2.0
2009-12	SA#46	SP-090812	368	-	Security considerations for emergency sessions in SRVCC	9.1.0	9.2.0
2009-12	SA#46	SP-090812	369	1	Delete the CK keys in the MSC server enhanced for SRVCC in case there is desynchronization of CS keys between the UE and the network in SRVCC	9.1.0	9.2.0
2009-12	SA#46	SP-090811	371	-	NAS COUNT handling during IRAT handover	9.1.0	9.2.0
2009-12	SA#46	SP-090811	373	-	Concurrency of inter-RAT handovers and NAS SMC procedure (Rel-9)	9.1.0	9.2.0
2009-12	SA#46	SP-090812	375	1	Using P-TMSI signature when attaching to SGSN using a GUTI (Rel-9)	9.1.0	9.2.0
2009-12	SA#46	SP-090889	376	4	Key-Chaining issue in I-RAT handover to UTRAN	9.1.0	9.2.0
2010-04	SA#47	SP-100097	384	-	GPRS Kc128 handling	9.2.0	9.3.0
2010-04	SA#47	SP-100099	386	-	Handling of SIM based EC handover to E-UTRAN	9.2.0	9.3.0
2010-04	SA#47	SP-100099	377	-	Key derivations for unauthenticated Emergency call	9.2.0	9.3.0
2010-04	SA#47	SP-100103	319	2	Clarification of SIM user handover from UTRAN to E-UTRAN	9.2.0	9.3.0
2010-04	SA#47	SP-100103	387	1	Correction of text on terminal identities	9.2.0	9.3.0
2010-04	SA#47	SP-100101	392	1	Clarification of Identification procedure in MME	9.2.0	9.3.0
2010-04	SA#47	SP-100101	403	-	Handling of EPS NAS security context in state transitions	9.2.0	9.3.0
2010-04	SA#47	SP-100103	378	1	Add the Replay protection implementation and Clarification of replay protection with integrity	9.2.0	9.3.0
2010-04	SA#47	SP-100103	389	-	Clarification for NAS downlink COUNT handling in I-RAT handover to UTRAN	9.2.0	9.3.0
2010-04	SA#47	SP-100101	382	1	GPRS Kc handling	9.2.0	9.3.0
2010-04	SA#47	SP-100101	399	1	Desynchronization of PS keys between the UE and the network in case of PS HO failure	9.2.0	9.3.0
2010-04	SA#47	SP-100101	383	1	Correction of SRVCC failure	9.2.0	9.3.0
2010-04	SA#47	SP-100106	395	2	Correction on mandatory implementation of IKE and IPsec for backhaul of eNBs	9.2.0	9.3.0
2010-04	SA#47	SP-100106	376	2	Correction of Network Domain Control Plane protection	9.2.0	9.3.0
2010-04	SA#47	SP-100101	397	1	Not resetting START to 0 in idle mode mobility (Rel-9).	9.2.0	9.3.0
2010-04	SA#47	SP-100106	404	-	Certificate Enrolment use	9.2.0	9.3.0

2010-04	--	--	--	--	Correction of reference [27]	9.3.0	9.3.1
2010-06	SA#48	SP-100382	414	1	IMEI sending clarification	9.3.1	9.4.0
2010-06	SA#48	SP-100382	420	1	Editorial Corrections	9.3.1	9.4.0
2010-06	SA#48	SP-100383	408	1	Correction of text on emergency call handling	9.3.1	9.4.0
2010-06	SA#48	SP-100383	409	1	Emergency Context Lifetime	9.3.1	9.4.0
2010-06	SA#48	SP-100382	410	1	Clarifying the uplink NAS COUNT for derivation of KeNB	9.3.1	9.4.0
2010-06	SA#48	SP-100383	412	2	Uplink and Downlink NAS COUNT increment for EIA0	9.3.1	9.4.0
2010-06	SA#48	SP-100383	413	1	Correction for Emergency Attach	9.3.1	9.4.0
2010-06	SA#48	SP-100382	415	1	Correction of TAU procedure after IRAT Handover to E-UTRAN	9.3.1	9.4.0
2010-06	SA#48	SP-100382	416	1	Correction on key sending in S1 HANDOVER REQUIRED message	9.3.1	9.4.0
2010-06	SA#48	SP-100382	418	1	Correction of BEARER-ID to BEARER	9.3.1	9.4.0
2010-10	SA#49	SP-100477	423	1	Corrections	9.4.0	9.5.0
2010-10	SA#49	SP-100569	424	-	Emergency call corrections	9.4.0	9.5.0
2010-12	SA#50	SP-100850	425	1	Emergency call corrections	9.5.0	9.6.0
2010-12	SA#50	SP-100721	426	1	Authentication Failure Handling	9.5.0	9.6.0
2010-12	SA#50	SP-100721	427	-	Correction of algorithm selection	9.5.0	9.6.0
2010-12	SA#50	SP-100852	429	1	Clarification for EIA0 selection during IRAT handover to EUTRAN	9.5.0	9.6.0
2011-03	SA#51	SP-110016	431	1	Correction for handover from UTRAN to E-UTRAN	9.6.0	10.0.0
2011-03	SA#51	SP-110015	437	1	PDPC integrity for relay node security	9.6.0	10.0.0
2011-03	SA#51	SP-110015	438	1	Solution for relay node security	9.6.0	10.0.0
2011-06	SA#52	SP-110256	440	1	Corrective text for undefined wording - autonomous validation of RN platform	10.0.0	10.1.0
2011-06	SA#52	SP-110256	444	1	Detailed binding of RN and UICC	10.0.0	10.1.0
2011-06	SA#52	SP-110256	445	1	Clarification on initial attach procedure for PSK case	10.0.0	10.1.0
2011-06	SA#52	SP-110256	448	1	Clarification of certificate and subscription handling	10.0.0	10.1.0
2011-06	SA#52	SP-110256	449	1	Resolution of Editor's Notes for PDPC integrity for Relay Nodes	10.0.0	10.1.0
2011-06	SA#52	SP-110256	451	1	Specification of secure channel profiles and certificates used for Relay nodes (RNs) and UICC (USIM-RN)	10.0.0	10.1.0
2011-06	SA#52	SP-110256	452	1	Resolution of Editor's Notes for Relay Node security procedures	10.0.0	10.1.0
2011-06	SA#52	SP-110256	453	1	Corrections and Clarifications for Relay Node security procedures	10.0.0	10.1.0
2011-06	SA#52	SP-110256	454	1	Correction on communication outside secure channel for Relay Node security procedures	10.0.0	10.1.0
2011-06	SA#52	SP-110259	459	2	Modification of security context storage rate	10.0.0	10.1.0
2011-06	SA#52	SP-110256	460	-	Corrections to communication between MME and DeNB for relay nodes	10.0.0	10.1.0
2011-06	SA#52	SP-110270	428	-	EPS algorithm negotiation during UTRAN to E-UTRAN handover	10.1.0	11.0.0
2011-06	--	--	--	--	Corrections to CR implementation	11.0.0	11.0.1
2011-09	SA#53	SP-110505	461	1	Adding ZUC algorithm in SAE/LTE security	11.0.1	11.1.0
2011-09	SA#53	SP-110505	468	1	Test vectors for 128-EIA1	11.0.1	11.1.0
2011-09	SA#53	SP-110505	469	1	Corrections on RN start-up security procedures	11.0.1	11.1.0
2011-09	SA#53	SP-110505	471	2	Clarification of integrity protection for relay nodes	11.0.1	11.1.0
2011-09	SA#53	SP-110505	473	-	Clarification on PDPC integrity requirement for Un interface	11.0.1	11.1.0

2011-09	SA#53	SP-110505	475	1	Correction on eNB management connection security	11.0.1	11.1.0
2011-09	SA#53	SP-110505	477	1	Correction on RN management connection security	11.0.1	11.1.0
2011-09	SA#53	SP-110505	479	1	Specification of profile and revocation handling for UICC certificates with relay nodes	11.0.1	11.1.0
2011-12	SA#54	SP-110848	483	1	CR on 33.401 DSCP use with IPsec	11.1.0	11.2.0
2011-12	SA#54	SP-110848	484	1	CR-Clarification for handover from E-UTRAN to UTRAN	11.1.0	11.2.0
2011-12	SA#54	SP-110848	486	1	Context identification at inter-RAT TAU procedures	11.1.0	11.2.0
2011-12	SA#54	SP-110848	487	1	Clarification of the KDF used in the key calculations	11.1.0	11.2.0
2012-03	SA#55	SP-120039	488	1	Clarifying Un user plane ciphering	11.2.0	11.3.0
			489	1	SRVCC HO from CS GERAN/UTRAN to PS E-UTRAN		
			491	1	Clarification of security requirements for backhaul of eNBs		
			493	1	Storing START in ME at mobility events (33.401)		
2012-06	SA#56	SP-120341	494	-	Clarifying Un user plane ciphering	11.3.0	11.4.0
2012-06	SA#56	SP-120341	495	1	Alignment of rSRVCC cases for HSPA and E-UTRAN	11.3.0	11.4.0
2012-06	SA#56	SP-120339	499	1	Addition of confidentiality requirement for interfaces carrying subscriber specific sensitive data	11.3.0	11.4.0
2012-06	SA#56	SP-120343	501		Miscellaneous corrections with respect to relay nodes	11.3.0	11.4.0
2012-06	SA#56	SP-120343	502	1	Pending downlink UP data at intra-LTE TAU	11.3.0	11.4.0
2012-09	SA#57	SP-120605	504	-	Length of truncated NAS token	11.4.0	11.5.0
2012-09	SA#57	SP-120605	505	-	Corrections to rSRVCC cases for E-UTRAN	11.4.0	11.5.0
2012-09	SA#57	SP-120602	503	-	Alignment of rule for running EPS-AKA at IRAT mobility Note that strange version number is a result of wrong version number shown on cover of this CR (12.4.0)	11.5.0	12.5.0
2012-10					Correction of previous entry in history table	12.5.0	12.5.1
2012-12	SA#58	SP-120856	506	1	CR-Corrections to 33.401	12.5.1	12.6.0
2012-12	SA#58	SP-120856	507	1	Editorial correction to Attach in UTRAN	12.5.1	12.6.0
2013-03	SA#59	SP-130038	518	1	SRVCC-correction-REL-12	12.6.0	12.7.0
2013-06	SA#60	SP-130252	519	1	Clarification for handover from UTRAN to E-UTRAN-R12	12.7.0	12.8.0
2013-06					Correction of a typo in history table	12.8.0	12.8.1
2013-09	SA#61	SP-130838	522	1	Revision of clause on KeNB re-keying	12.8.1	12.9.0
2013-12	SA#62	SP-130667	523	-	Correction of a typo	12.9.0	12.10.0
2014-06	SA#64	SP-140314	525	1	Security functionality for dual connectivity	12.10.0	12.11.0
2014-09	SA#65	SP-140590	526	-	Solving editor's note on SCC length	12.11.0	12.12.0
			532	1	Removal of Editor Notes from Sections and clean up related to Dual Connectivity		
			535	1	Add Dual Connectivity Acronyms		
2014-12	SA-66	SP-140827	540	-	Modifying undetermined reference clauses and Correcting the title heading of E.2	12.12.0	12.13.0
		SP-140830	541	-	Clarification on implementation requirement of EIA0 in RN		
		SP-140827	542	1	Key stream re-using caused by DRB type change (+ Editorial correction changing font from Body Text to Normal in Annex C)		
		SP-140824	543	1	Clarification on radio link failure recovery		
		SP-140824	544	1	S-KeNB update in UE		
2015-03	SA-67	SP-150076	546	1	Corrections on SCG security algorithm negotiation	12.13.0	12.14.0
2015-09	SA-69	SP-150475	551	1	Adapting KeNB* derivation function due to extended range of EARFCN-DL	12.14.0	12.15.0
			552	1	Adapting KeNB* derivation function due to extended range of EARFCN-DL	12.15.0	13.0.0
2015-12	SA-70	SP-150727	561	1	Clarification on MME behaviour for selection of integrity and confidentiality algorithms for VoLTE emergency calls	13.0.0	13.1.0
			562	1	Security considerations on the proposed security solution for IOPS		
			563	-	Addition of an informative annex to TS 33.401 containing security guidelines for IOPS		

2016-03	SA-71	SP-160055	570	1	LWIP Security Support	13.1.0	13.2.0
2016-03	SA-71	SP-160198	566	2	Update to IOPS security considerations	13.1.0	13.2.0
2016-03	SA-71	SP-160052	564	2	Add NB-IoT keys and processes	13.1.0	13.2.0
2016-03	SA-71	SP-160197	568	3	Security aspects of LTE-WLAN aggregation	13.1.0	13.2.0

Change history							
Date	Meeting	TDoc	CR	Rev	Cat	Subject/Comment	New version
2016-06	SA#72	SP-160390	0574	1	F	Change of the LWA architecture	13.3.0
2016-06	SA#72	SP-160456	0579	1	F	Change of the LWA architecture description	13.3.0
2016-06	SA#72	SP-160386	0580	1	B	Security for RRC suspend and resume	13.3.0
2016-06	SA#72	SP-160390	0585	1	F	Risk of User Privacy in LWA	13.3.0
2016-06	SA#72	SP-160386	0588	1	F	Partial ciphering mechanism for user data via the MME and NAS COUNTs clarification	13.3.0
2016-09	SA#73	SP-160579	0591	-	F	Editor Notes in RRC Suspend and Resume	13.4.0
2016-09	SA#73	SP-160582	0592	1	F	LWA editorial corrections	13.4.0
2016-09	SA#73	SP-160582	0593	-	F	LWIP - Correction of the UEs IP address	13.4.0
2016-09	SA#73	SP-160580	0584	2	C	Protecting against the modification of Attach/TAU Request attacks	14.0.0
2016-09	SA#73	SP-160580	0594	1	B	Installing PMK at the WLAN AP using EAP	14.0.0
2016-12	SA#74	SP-160788	0599	-	F	Correcting LWA-ID derivation mismatch	14.1.0
2017-03	SA#75	SP-170099	0601	-	F	Correct the IANA vendor id for 3GPP	14.2.0
2017-03	SA#75	SP-170099	0602	-	F	Correct the reference to the NAS specification	14.2.0
2017-06	SA#76	SP-170425	0606	1	F	Reference to list of 3GPP vendor specific EAP methods	14.3.0
2017-06	SA#76	SP-170425	0607	1	F	Alignment of LWIP to stage 3	14.3.0
2017-06	SA#76	SP-170425	0610	1	F	Changes to Security Key Update	14.3.0
2017-06	SA#76	SP-170425	0615	1	F	Details of the calculation of HASH_MME and HASH_UE	14.3.0
2017-06	SA#76	SP-170424	0612	1	D	Tidying up the eNB to eNB dual connectivity	15.0.0
2017-06	SA#76	SP-170424	0617	-	D	Correction of reference	15.0.0
2017-09	SA#77	SP-170637	0618	1	F	KeNB calculation at initialisation of S1-U DRBs for UEs using control plane optimisations	15.1.0
2017-09	SA#77	SP-170645	0619	-	B	Solution for Dual Connectivity between MeNB and SgNB	15.1.0
2018-01	SA#78	SP-170873	0620	-	F	Corrections to SgNB security procedures	15.2.0
2018-01	SA#78	SP-170873	0623	1	D	Editorial corrections for Annex E	15.2.0
2018-01	SA#78	SP-170873	0625	3	F	Aligning the specification of the key derivation function for key to use in security algorithms between UE and SgNB in EDCE5 with the 5G specification	15.2.0
2018-01	SA#78	SP-170873	0628	-	F	Clarifying the security algorithms that are used between the UE and MeNB and the UE and SgNB	15.2.0
2018-01	SA#78	SP-170873	0629	-	F	Adding a reference to RAN procedures on EDCE5	15.2.0
2018-01	SA#78	SP-170873	0630	-	F	Clarifying the behaviour of UE to SgNB connection at a MeNB handover	15.2.0
2018-01	SA#78	SP-170873	0632	2	D	Clause E Dual Connectivity ENs	15.2.0
2018-01	SA#78	SP-170872	0634	-	A	Clause 7.2.4.4 (Rectifying use of HASH_MME at NAS_SMC in Rel-15)	15.2.0
2018-01	SA#78	SP-170873	0641	1	F	Aligning the algorithm names between EDCE5 and 5G	15.2.0
2018-01	SA#78	SP-170876	0644	1	F	Security for the RLFs for UEs doing user plane over control plane using NAS level security for Rel-15 specification	15.2.0
2018-01	SA#78	SP-170872	0646	2	A	Improve and clarify texts under NOTE	15.2.0
2018-01	SA#78	SP-170873	0647	1	F	Corrections to deletion of SCG Keys	15.2.0
2018-01	SA#78	SP-170873	0648	-	F	Handling the algorithms for use between a UE and SgNB for EN-DC	15.2.0
2018-03	SA#79	SP-180048	0650	1	F	Corrections and clarification for EDCE5	15.3.0
2018-03	SA#79	SP-180048	0654	-	F	Preventing the use of NIA0 between the UE and SgNB	15.3.0
2018-06	SA#80	SP-180451	0656	-	D	Correction and Clarification for EDCE5	15.4.0
2018-06	SA#80	SP-180449	0657	1	F	Correction and Clarification for the handling of KASME	15.4.0
2018-06	SA#80	SP-180451	0658	-	F	Correction and Clarification for EDCE5	15.4.0
2018-06	SA#80	SP-180451	0659	-	F	Referencing algorithm and key derivation description for EN-DC that exist in TS 33.501	15.4.0
2018-06	SA#80	SP-180451	0660	1	F	Clarify that both split bearers and SCG bearer may need security resources at the SgNB	15.4.0
2018-09	SA#81	SP-180705	0662	1	A	Alignment of terminology in RRCConnctionReestablsihment Procedure in R15	15.5.0
2018-09	SA#81	SP-180704	0664	1	B	LTE - updating suspend/resume procedures to include EDT	15.5.0
2018-09	SA#81	SP-180705	0666	1	A	Clarifications on the calculation of NAS-MAC for RRCConnction re-establishmentwith Control Plane Clot optimisations (Rel-15)	15.5.0
2018-12	SA#82	SP-181028	0668	1	F	Correction on LTE suspend/resume procedure for EDT capable UE	15.6.0
2018-12	SA#82	SP-181028	0699	1	F	User Plane Integrity Protection for EDT	15.6.0
2019-03	SA#83	SP-190103	0674	1	F	EDT correction - length of HASHUE-data and HASHeNB-data	15.7.0
2019-03	SA#83	SP-190103	0675	-	F	EDT correction - input to calculation of shortResumeMAC-I	15.7.0
2019-06	SA#84	SP-190358	0679	1	F	Correction of ShortResumeMAC-I calculation for EDT	15.8.0
2019-09	SA#85	SP-190684	0681	-	F	Clarification of NIA0 with SgNB for UE NR capability	15.9.0
2019-09	SA#85	SP-190682	0680	3	B	Adding KASME_SRVCC as a possible input key to derive IKSRVCC and CKSRVCC	16.0.0
2019-12	SA#86	SP-191140	0686	-	A	RRC Connection Suspend and Resume	16.1.0
2019-12	SA#86	SP-191132	0687	2	B	Security aspects of RLOS	16.1.0
2020-03	SA#87E	SP-200139	0689	1	F	UE handling on CHO key derivation for LTE	16.2.0

2020-03	SA#87E	SP-200139	0690	1	C	Key derivation for CHO(LTE R16)	16.2.0
2020-03	SA#87E	SP-200144	0691	-	B	Solution for IAB Architecture - ENDC	16.2.0
2020-07	SA#88E	SP-200366	0694	1	C	UE caps protection using AS security in EPS Rel-16	16.3.0
2020-07	SA#88E	SP-200367	0695	2	B	Security Aspects of DNS and ICMP	16.3.0
2020-07	SA#88E	SP-200368	0697	-	F	Add requirement for OAM to IAB ENDC	16.3.0

History

Document history		
V16.3.0	August 2020	Publication