

ETSI TS 134 109 V6.0.0 (2004-12)

Technical Specification

**Universal Mobile Telecommunications System (UMTS);
Terminal logical test interface;
Special conformance testing functions
(3GPP TS 34.109 version 6.0.0 Release 6)**



Reference

RTS/TSGR-0234109v600

Keywords

UMTS

ETSI

650 Route des Lucioles
F-06921 Sophia Antipolis Cedex - FRANCE

Tel.: +33 4 92 94 42 00 Fax: +33 4 93 65 47 16

Siret N° 348 623 562 00017 - NAF 742 C
Association à but non lucratif enregistrée à la
Sous-Préfecture de Grasse (06) N° 7803/88

Important notice

Individual copies of the present document can be downloaded from:

<http://www.etsi.org>

The present document may be made available in more than one electronic version or in print. In any case of existing or perceived difference in contents between such versions, the reference version is the Portable Document Format (PDF). In case of dispute, the reference shall be the printing on ETSI printers of the PDF version kept on a specific network drive within ETSI Secretariat.

Users of the present document should be aware that the document may be subject to revision or change of status. Information on the current status of this and other ETSI documents is available at

<http://portal.etsi.org/tb/status/status.asp>

If you find errors in the present document, please send your comment to one of the following services:

http://portal.etsi.org/chaicor/ETSI_support.asp

Copyright Notification

No part may be reproduced except as authorized by written permission.
The copyright and the foregoing restriction extend to reproduction in all media.

© European Telecommunications Standards Institute 2004.
All rights reserved.

DECTTM, **PLUGTESTS**TM and **UMTS**TM are Trade Marks of ETSI registered for the benefit of its Members.
TIPHONTM and the **TIPHON logo** are Trade Marks currently being registered by ETSI for the benefit of its Members.
3GPPTM is a Trade Mark of ETSI registered for the benefit of its Members and of the 3GPP Organizational Partners.

Intellectual Property Rights

IPRs essential or potentially essential to the present document may have been declared to ETSI. The information pertaining to these essential IPRs, if any, is publicly available for **ETSI members and non-members**, and can be found in ETSI SR 000 314: "*Intellectual Property Rights (IPRs); Essential, or potentially Essential, IPRs notified to ETSI in respect of ETSI standards*", which is available from the ETSI Secretariat. Latest updates are available on the ETSI Web server (<http://webapp.etsi.org/IPR/home.asp>).

Pursuant to the ETSI IPR Policy, no investigation, including IPR searches, has been carried out by ETSI. No guarantee can be given as to the existence of other IPRs not referenced in ETSI SR 000 314 (or the updates on the ETSI Web server) which are, or may be, or may become, essential to the present document.

Foreword

This Technical Specification (TS) has been produced by ETSI 3rd Generation Partnership Project (3GPP).

The present document may refer to technical specifications or reports using their 3GPP identities, UMTS identities or GSM identities. These should be interpreted as being references to the corresponding ETSI deliverables.

The cross reference between GSM, UMTS, 3GPP and ETSI identities can be found under <http://webapp.etsi.org/key/queryform.asp>.

Contents

Intellectual Property Rights	2
Foreword.....	2
Foreword.....	5
1 Scope	6
2 References	6
3 Definitions and abbreviations.....	7
3.1 Definitions	7
3.2 Abbreviations	7
4 UE conformance test functions	7
4.1 General description.....	7
4.2 UE radio bearer test mode	8
4.3 UE test loop.....	9
4.4 EMMI.....	9
5 Test Control (TC) protocol procedures and test loop operation.....	9
5.1 General description.....	9
5.2 UE radio bearer test mode procedures.....	10
5.2.1 Activate UE radio bearer test mode	10
5.2.1.1 General	10
5.2.1.2 Initiation.....	11
5.2.1.3 Reception of ACTIVATE RB TEST MODE message by UE	11
5.2.1.4 Reception of ACTIVATE RB TEST MODE COMPLETE message by SS	11
5.2.1.5 TT01 timeout.....	11
5.2.2 Deactivate UE radio bearer test mode.....	11
5.2.2.1 General	11
5.2.2.2 Initiation.....	11
5.2.2.3 Reception of DEACTIVATE RB TEST MODE message by UE.....	12
5.2.2.4 Reception of DEACTIVATE RB TEST MODE COMPLETE message by SS.....	12
5.2.2.5 TT01 timeout.....	12
5.3 UE test loop procedures	12
5.3.1 General.....	12
5.3.2 Close UE test loop	12
5.3.2.1 General	13
5.3.2.2 Initiation.....	13
5.3.2.3 Reception of CLOSE UE TEST LOOP message by the UE.....	13
5.3.2.4 Reception of CLOSE UE TEST LOOP COMPLETE message by the SS.....	13
5.3.2.5 TT01 timeout.....	13
5.3.2.6 UE test loop mode 1 operation.....	13
5.3.2.6.1 Loopback of PDCP SDUs	13
5.3.2.6.2 Loopback of RLC SDUs.....	14
5.3.2.7 UE test loop mode 2 operation.....	15
5.3.2.7.1 Loopback of downlink transport block data and downlink CRC.....	15
5.3.2.8 Void.....	16
5.3.2.9 Loopback delay requirement	16
5.3.2.9.1 General loopback delay requirement	16
5.3.2.9.2 Loopback delay requirement for RLC and PDCP SDUs (UE Test loop mode 1)	18
5.3.3 Open UE test loop.....	18
5.3.3.1 General	19
5.3.3.2 Initiation.....	19
5.3.3.3 Reception of OPEN UE TEST LOOP message by the UE	19
5.3.3.4 Reception of OPEN UE TEST LOOP COMPLETE by the SS.....	19
5.3.3.5 TT01 timeout.....	19
5.4 UE Positioning test mode procedures.....	19
5.4.1 Reset UE Positioning Stored Information.....	19

5.4.1.1	General	19
5.4.1.2	Initiation	19
5.4.1.3	Reception of RESET UE POSITIONING STORED INFORMATION message by UE	19
6	Message definitions and contents	20
6.1	Timer values	20
6.2	CLOSE UE TEST LOOP	20
6.3	CLOSE UE TEST LOOP COMPLETE	21
6.4	OPEN UE TEST LOOP	22
6.5	OPEN UE TEST LOOP COMPLETE	22
6.6	ACTIVATE RB TEST MODE	22
6.7	ACTIVATE RB TEST MODE COMPLETE	23
6.8	DEACTIVATE RB TEST MODE	23
6.9	DEACTIVATE RB TEST MODE COMPLETE	23
6.10	RESET UE POSITIONING STORED INFORMATION	24
7	Electrical Man Machine Interface (EMMI)	24
8	UICC/ME test interface	25
8.1	General description	25
8.2	Formal aspects	25
8.3	Hardware and logical aspects of the interface	25
8.4	Mechanical characteristics of the interface	25
Annex A (informative):	UE test loop use scenarios	26
A.1	Measurement of receiver characteristics (BER) using UE test loop mode 1 and RLC TM	26
A.1.1	Measurement of receiver characteristics (BER) - DL reference measurement channel (12.2 kbps)	26
A.2	Measurement of receiver performance (BLER) using UE test loop mode 1 and RLC AM	26
A.2.1	Measurement of receiver performance (BLER) - DL reference measurement channel (64,144,384 kbps)	27
A.3	Measurement of receiver performance (BLER) using UE test loop mode 2	27
A.3.1	Measurement of receiver performance (BLER) - DL reference measurement channel (12.2 kbps)	28
A.3.2	Measurement of receiver performance (BLER) - DL reference measurement channel (64,144 and 384 kbps)	28
A.4	Measurement of transmitter characteristics	28
A.5	Measurement of transmitter DTX characteristics	29
A.6	Using UE test loop mode 2 for testing of UE Blind Transport Format Detection (FDD mode)	29
A.7	Using UE test loop mode 1 for protocol testing	30
Annex B (informative):	Change history	32
History		33

Foreword

This Technical Specification has been produced by the 3rd Generation Partnership Project (3GPP).

The contents of the present document are subject to continuing work within the TSG and may change following formal TSG approval. Should the TSG modify the contents of the present document, it will be re-released by the TSG with an identifying change of release date and an increase in version number as follows:

Version x.y.z

where:

- x the first digit:
 - 1 presented to TSG for information;
 - 2 presented to TSG for approval;
 - 3 or greater indicates TSG approved document under change control.
- y the second digit is incremented for all changes of substance, i.e. technical enhancements, corrections, updates, etc.
- z the third digit is incremented when editorial only changes have been incorporated in the document.

1 Scope

The present document specifies for User Equipment (UE), in UMTS system, for FDD and TDD modes, those UE functions that are required for conformance testing purposes.

For conformance tests, functions are activated via the radio interface. These functions shall be capable of being activated when a test USIM is present. Any USIM related features such as subsidy-related UE features should also not interfere with the functions. In the loopback state, the UE shall be able to perform all functions specified in the present document except where otherwise stated; in addition however, the conformance testing functions must be operational.

USIM, in general, is described in TS 31.101 [7]. The ME recognises the test USIM by the Administrative Data Field. Test USIM data fields are described in TS 34.108 [10].

The present document applies to the unit that includes the hardware to establish a connection across the radio interface.

2 References

The following documents contain provisions that, through reference in this text, constitute provisions of the present document.

- References are either specific (identified by date of publication, edition number, version number, etc.) or non-specific.
- For a specific reference, subsequent revisions do not apply.
- For a non-specific reference, the latest version applies. In the case of a reference to a 3GPP document (including a GSM document), a non-specific reference implicitly refers to the latest version of that document *in the same Release as the present document*.

- [1] 3GPP TS 24.007: "Mobile radio interface signalling layer 3; General aspects".
- [2] 3GPP TS 24.008: "Mobile radio interface layer 3 specification; Core Network Protocols; Stage 3".
- [3] 3GPP TS 25.101: "UE Radio transmission and reception (FDD)".
- [4] 3GPP TS 25.102: "UTRA (UE) TDD; Radio transmission and reception".
- [5] 3GPP TS 25.331: "Radio Resource Control (RRC); protocol specification".
- [6] 3GPP TR 21.905: "Vocabulary for 3GPP Specifications".
- [7] 3GPP TS 31.101: "UICC-Terminal Interface; Physical and Logical Characteristics".
- [8] 3GPP TS 34.121: "Terminal Conformance Specification; Radio Transmission and Reception (FDD)".
- [9] 3GPP TS 34.122: "Terminal Conformance Specification; Radio Transmission and Reception (TDD)".
- [10] 3GPP TS 34.108: "Common Test Environments for User Equipment (UE) Conformance Testing".
- [11] 3GPP TS 25.211: "Physical channels and mapping of transport channels onto physical channels (FDD)".
- [12] 3GPP TS 25.133: "Requirements for support of Radio Resource Management (FDD)".
- [13] 3GPP TS 44.014: "Individual equipment type requirements and interworking; Special conformance testing functions".
- [14] 3GPP TS 27.005: "Use of Data Terminal Equipment - Data Circuit terminating Equipment (DTE - DCE) interface for Cell Broadcast Service (CBS)".

- [15] 3GPP TS 27.007: "AT command set for User Equipment (UE)".
- [16] 3GPP TS 27.060: "Mobile Stations (MS) supporting packet switched services".
- [17] 3GPP TS 34.123-2: "User Equipment (UE) conformance specification; Part 2: Implementation Conformance Statement (ICS) proforma specification".
- [18] 3GPP TS 25.306: "UE Radio Access capabilities".

3 Definitions and abbreviations

3.1 Definitions

For the purposes of the present document, the following terms and definitions apply:

UE (User Equipment): user equipment that is under test.

SS (System Simulator): test system (or equipment) that drives the test process between UE, like BS (Base Station) simulator.

User: test user, who handles the test and measurement process via the logical test interface.

Logical Test Interface: interface which provides the logical service to interwork and to communicate between UE and System Simulator during the test of a UE.

TC (Test Control): UE protocol entity used by the SS to control the UE specific testing functions.

3.2 Abbreviations

Abbreviations used in the present document are listed in TR 21.905 [6].

For the purposes of the present document, the following abbreviations apply:

LB	Loop Back
RAB	Radio Access Bearer
RB	Radio Bearer
SAPI	Service Access Point Indicator
SS	System Simulator
TC	Test Control
UICC	UMTS Integrated Circuit Card

4 UE conformance test functions

4.1 General description

The SS performs activation and deactivation of the conformance test functions in the UE by sending standard NAS Layer 3 messages. A specific protocol discriminator value has been defined in TS 24.007 [1], subclause 11.2.3.1.1 for the UE test command messages. Figure 4.1.1 illustrates the Layer 3 protocol entity Test Control (TC) where the UE test command messages terminates.

NOTE: The protocol discriminator value used for the TC messages is the same as used in GSM for the MS specific testing functions, see TS 44.014 [13].

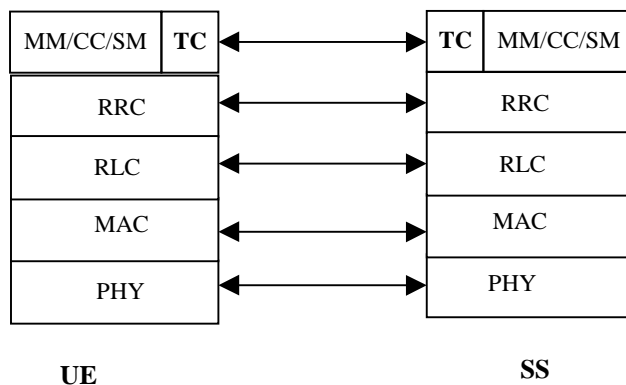

Figure 4.1.1: TC protocol termination (TC =Test Control)

Apart from sending the appropriate deactivation command to the UE the functions shall be deactivated by switching off the UE.

The following UE conformance testing functions can be activated (and deactivated):

- UE test loop function;
- UE radio bearer test mode;
- Electrical Man Machine Interface (EMMI).

In addition to the conformance testing functions listed above there is a set of reference measurement channels that a UE need to support to enable RF conformance testing. The reference measurement channels are defined in TS 34.121 [8], Annex C for FDD and in TS 34.122 [9], Annex C for TDD.

Example of reference measurement channels (RMC) essential to all UEs supporting FDD or TDD are:

- UL 12.2 kbps RMC (Reference Measurement Channel);
- DL 12.2 kbps RMC.

Example of reference measurement channels associated with UE service capabilities for FDD (DL and UL) and TDD (DL only) are:

- DL 64 kbps RMC;
- DL 144 kbps RMC;
- DL 384 kbps RMC;
- UL 64 kbps RMC;
- UL 144 kbps RMC;
- UL 384 kbps RMC.

4.2 UE radio bearer test mode

The UE radio bearer test mode is specified in subclause 5.2.

The following TC procedures are used to control the UE radio bearer test mode:

- Activate UE radio bearer test mode;
- Deactivate UE radio bearer test mode.

4.3 UE test loop

The UE test loop function is specified in subclause 5.3.

The following TC procedures are used to control the UE test loop function:

- Close UE test loop;
- Open UE test loop.

A prerequisite for the UE test loop function is that the UE radio bearer test mode is active.

4.4 EMMI

The EMMI is specified in clause 7.

No specific TC procedures are associated with EMMI.

5 Test Control (TC) protocol procedures and test loop operation

5.1 General description

The UE test loop function provides access to isolated functions of the UE via the radio interface without introducing new physical interfaces just for the reason of conformance testing.

NOTE: It should be emphasised that the UE test loop function only describes the functional behaviour of the UE with respect to its external interfaces; physical implementation of the UE test loop function is completely left open to the manufacturer.

The UE test loop function is activated by transmitting the appropriate Test Control (TC) message to the UE, see clause 6.

The UE test loop function can be operated in two different loopback modes:

- UE test loop mode 1; and
- UE test loop mode 2.

Figure 5.1.1 shows a functional block diagram of UE test loop function for mode 1.

For UE test loop mode 1 the loopback point is located above Layer 2. Depending on the actual radio bearer setup loopback is performed of RLC SDUs or PDCP SDUs according to the procedure specified in subclause 5.3.3.2.

The loop back point for UE test loop mode 1 has been selected above Layer 2 to separate the protocol configurations from the UE test loop function. By configuration of RLC and MAC layers other loop back points may functional be achieved. E.g. by transparent configuration of RLC and MAC layer functional loop back point at Transport channel level can be achieved to implement the reference measurement channels as specified by TS 34.121 [8], Annex C for FDD and by TS 34.122 [9], Annex C for TDD.

For UE test loop mode 2 both data and CRC are looped back. UE test loop mode 2 is intended for Blind Transport Format Detection (BTDF) testing and BLER testing of DL 12.2 kbps reference measurement channel for which loopback of downlink CRC is required. UE test loop mode 2 can also be used for BLER testing of DL 64, 144 and 384 kbps reference measurement channels if the UE supports correspondent UL reference measurement channels. Both received data and CRC bits for the DCH transport channel used for the BTDF test case is returned according to the procedure specified in subclause 5.3.3.3.

A specific radio bearer test mode is specified to be used together with the UE test loop function. The purpose of the radio bearer test mode is to put the UE into a mode where: SS can set up radio bearers to be terminated in the UE test

loop function without having to involve CC or SM; and to disable any control mechanisms in NAS protocols or in any UE applications that otherwise could cause the RRC connection to be released.

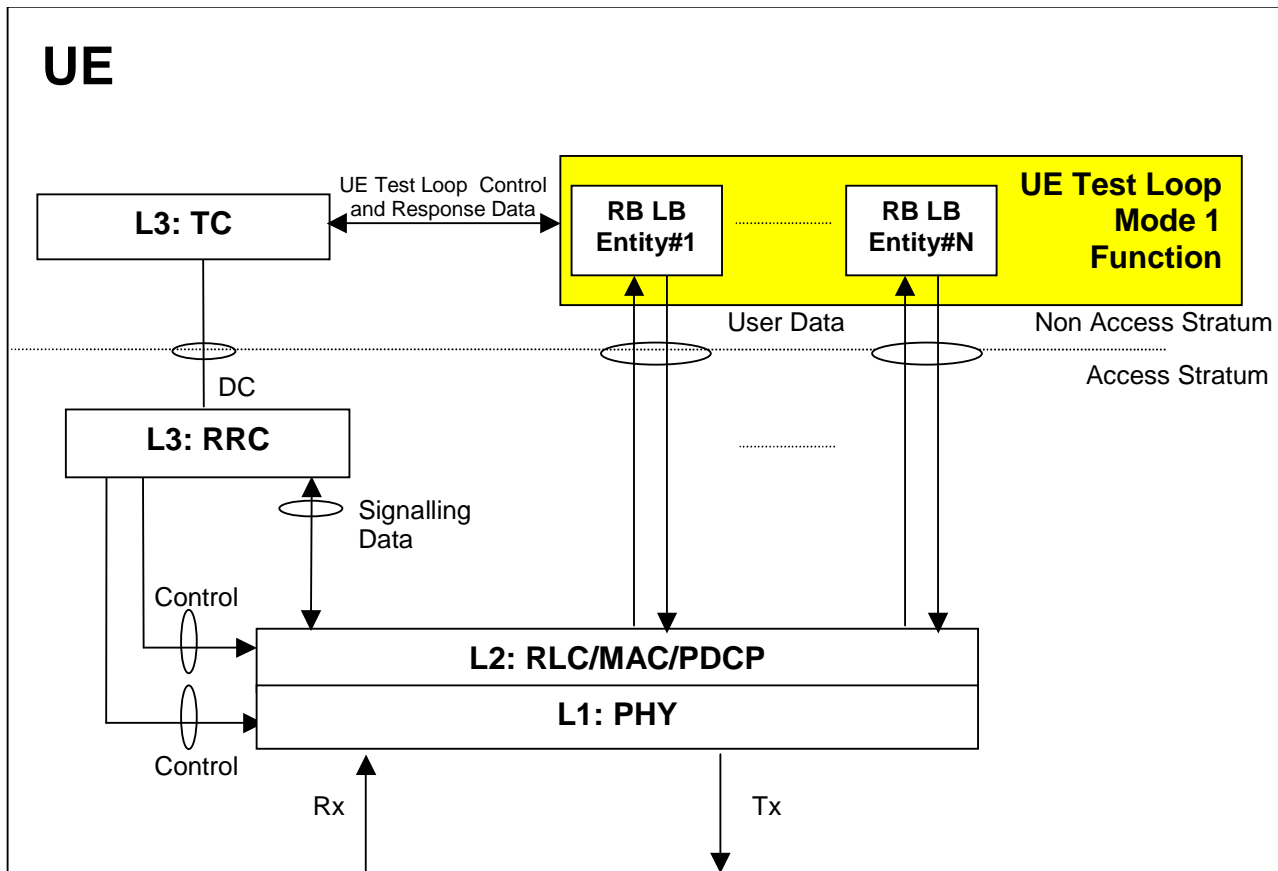

Figure 5.1.1: UE Test Loop Mode 1 function (TC =Test Control, LB = Loop Back entity)

5.2 UE radio bearer test mode procedures

5.2.1 Activate UE radio bearer test mode

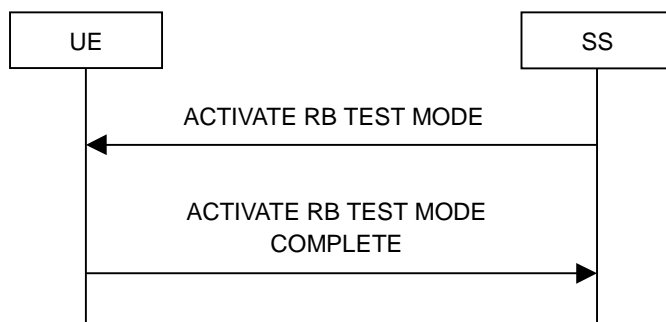

Figure 5.2.1.1: Activate UE radio bearer test mode procedure

5.2.1.1 General

The SS uses the activate UE radio bearer procedure to get UE into a test mode where: SS can set up radio bearers to be terminated in the UE test loop function without having to involve CC or SM; and to disable any control mechanisms in NAS protocols (TC protocol excluded) or in any UE applications that otherwise could cause the RRC connection to be released.

5.2.1.2 Initiation

The SS can initiate the UE radio bearer test mode when an RRC connection is established.

The SS requests the UE to activate the UE radio bearer test mode by transmitting an ACTIVATE RB TEST MODE message. The SS then starts timer TT01.

5.2.1.3 Reception of ACTIVATE RB TEST MODE message by UE

When UE receives ACTIVATE RB TEST MODE message then the radio bearer test mode shall be activated.

When the radio bearer test mode is active the UE shall:

- accept any requested radio bearer setup within the radio access capabilities of the UE;
- terminate all user plane radio bearer(s) in the UE test loop function; and
- disable any control mechanisms in NAS protocols or in any UE applications that otherwise could cause the RRC connection to be released.

When the radio bearer test mode has been activated the UE shall transmit the ACTIVATE RB TEST MODE COMPLETE message.

NOTE: When the radio bearer test mode is active the UE does not need to provide any CC or SM functionality.

5.2.1.4 Reception of ACTIVATE RB TEST MODE COMPLETE message by SS

Upon reception of the ACTIVATE RB TEST MODE COMPLETE message the SS stops timer TT01.

The reception of the ACTIVATE RB TEST MODE COMPLETE message by SS confirms that the UE radio bearer test mode has been activated in the UE.

5.2.1.5 TT01 timeout

If TT01 expires, then the SS shall indicate this to the test case. The procedure is then completed.

5.2.2 Deactivate UE radio bearer test mode

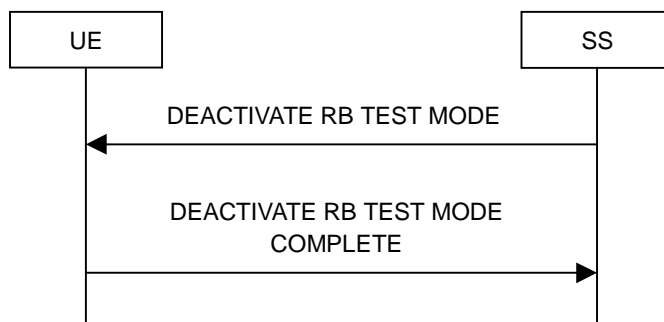

Figure 5.2.2.1: Deactivate UE radio bearer test mode procedure

5.2.2.1 General

The purpose of this procedure is to deactivate the radio bearer test mode and return UE to normal operation.

5.2.2.2 Initiation

The SS can deactivate the UE radio bearer test mode when an RRC connection is established and the UE radio bearer test mode is active.

The SS requests the UE to deactivate the UE radio bearer test mode by transmitting a DEACTIVATE RB TEST MODE message. The SS then starts timer TT01.

5.2.2.3 Reception of DEACTIVATE RB TEST MODE message by UE

When the UE receives DEACTIVATE RB TEST MODE message then the radio bearer test mode shall be deactivated and UE shall be returned to normal operation.

When the UE has deactivated the radio bearer test mode the UE shall transmit the DEACTIVATE RB TEST MODE COMPLETE message using the RRC UPLINK DIRECT TRANSFER message.

5.2.2.4 Reception of DEACTIVATE RB TEST MODE COMPLETE message by SS

Upon reception of the DEACTIVATE RB TEST MODE COMPLETE message the SS stops timer TT01.

The reception of DEACTIVATE RB TEST MODE COMPLETE message by SS confirms that the UE radio bearer test mode has been deactivated in the UE.

5.2.2.5 TT01 timeout

If TT01 expires, then the SS shall indicate this to the test case. The procedure is then completed.

5.3 UE test loop procedures

5.3.1 General

The UE test loop function is intended for:

- Testing of receiver characteristics based on BER (Bit Error Ratio) measurement. The SS calculates BER from a bit-by-bit comparison of data sent to and received from UE. BER measurement requires symmetric RAB bit-rates.
- Testing of receiver performance based on BLER (Block Error Ratio) measurement. The SS calculates BLER based on the RLC STATUS SDU received from the UE operating in RLC acknowledged mode; or the SS calculates BLER based on checking returned downlink data and downlink CRC by UE operating in UE test loop mode 2.
- Testing of UE Blind Transport Format Detection.
- Testing of UE transmitter characteristics.
- Testing of UE transmitter DTX characteristics.
- Testing of radio bearers (UE test loop function emulates terminal equipment).

5.3.2 Close UE test loop

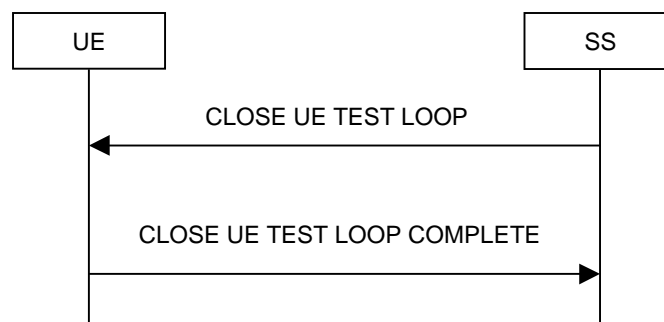

Figure 5.3.2.1: Close UE test loop procedure

5.3.2.1 General

The SS uses the close UE test loop procedure to start the UE Test Loop function in the UE. A prerequisite is that a radio bearer has been established between SS and UE. See TS 34.108 [10], clause 7 for generic setup procedures.

The UE shall provide for normal Uu layer 1, layer 2 and RRC functionality while the UE test loop function is active. This includes (but is not limited to) handover procedures and normal disconnection of the radio bearer. The loopback shall be maintained across handovers, but after radio bearer disconnection, the loopback shall cease to exist.

5.3.2.2 Initiation

The SS can request UE to close a test loop if a radio bearer is established and the UE radio bearer test mode is active.

The SS requests the UE to close its radio bearer test loop by transmitting a CLOSE UE TEST LOOP message. The SS then starts timer TT01.

5.3.2.3 Reception of CLOSE UE TEST LOOP message by the UE

If no radio bearer is established or the UE radio bearer test mode is not active, then the UE shall ignore any CLOSE UE TEST LOOP message.

If a radio bearer is established, the UE shall close the test loop and then send back to the SS a CLOSE UE TEST LOOP COMPLETE message. The loopback shall be operational prior to the sending of the acknowledgement.

If the test loop is already closed, the UE shall still respond as if the loop had been open, i.e. the CLOSE UE TEST LOOP COMPLETE message shall be sent.

NOTE: There is no requirement on the UE to read the content of the CLOSE UE TEST LOOP message if it is received while the test loop is closed.

If UE test mode 1 has been selected then the loop back scheme according to subclause 5.3.2.6 shall be performed by the UE.

If UE test mode 2 has been selected then the loop back scheme according to subclause 5.3.2.7 shall be performed by the UE.

5.3.2.4 Reception of CLOSE UE TEST LOOP COMPLETE message by the SS

Upon reception of the CLOSE UE TEST LOOP COMPLETE message the SS stops timer TT01.

5.3.2.5 TT01 timeout

If TT01 expires, then the SS shall indicate this to the test case. The procedure is then completed.

5.3.2.6 UE test loop mode 1 operation

If the configuration of a radio bearer includes the PDCP protocol layer, configured by "PDCP info" (see TS 25.331 [5]), then the loop back scheme according to subclause 5.3.2.6.1 shall be performed by the UE for the actual radio bearer.

If the PDCP protocol layer is not used for a radio bearer then the loop back scheme according to subclause 5.3.2.6.2 shall be performed by the UE for the actual radio bearer.

5.3.2.6.1 Loopback of PDCP SDUs

If UE test mode 1 have been selected and the radio bearer setup includes configuration of PDCP protocol layer, configured by "PDCP info" (see TS 25.331 [5]), then the following loop back scheme shall be performed by the UE.

After the UE has closed its radio bearer test loop, every PDCP SDU received by the UE on the active radio bearer (downlink) shall be taken from the output of the PDCP service access point (SAP) and be input to the correspondent PDCP SAP and transmitted (uplink).

The UE shall provide for normal PDCP operation.

The PDCP loopback operation is illustrated in figure 5.3.2.6.1.1.

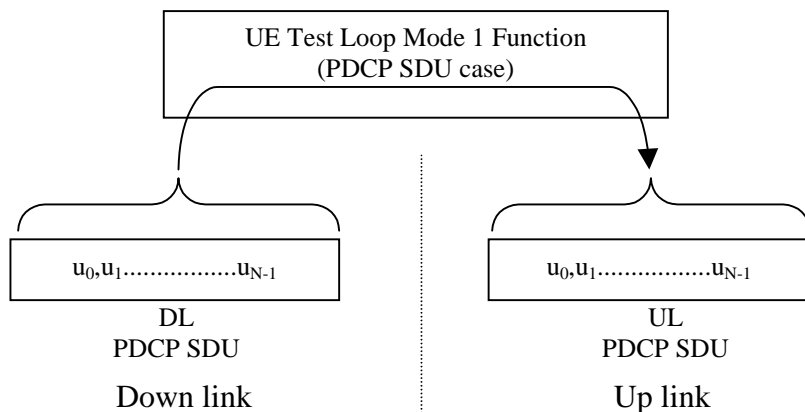

Figure 5.3.2.6.1.1: Loop back of PDCP SDU (DL RLC SDU size = UL RLC SDU size = N)

5.3.2.6.2 Loopback of RLC SDUs

If UE test mode 1 has been selected and radio bearer setup does not include configuration of PDCP protocol layer ("PDCP info" is not configured. See TS 25.331 [5]) then the following loop back scheme shall be performed by the UE.

After the UE has closed its radio bearer test loop, every user data block received by the UE on the active radio bearer (downlink) shall be taken from the output of the RLC service access point (SAP) and be input to the correspondent RLC SAP and transmitted (uplink). The UE reads the UL RLC SDU size parameter from the "LB Setup RB IE#k" parameter associated with the radio bearer, see subclause 6.2.

If no "LB Setup RB IE#k" parameter is associated with the radio bearer then the UE shall use the same UL RLC SDU size as the received DL RLC SDU.

For the case when the "UL RLC SDU size" parameter is set to "0" no data shall be returned.

For the case when the "UL RLC SDU size" parameter is set to the same value as the down link (DL) RLC SDU block size then the complete user data block shall be returned, see figure 5.3.2.6.2.1.

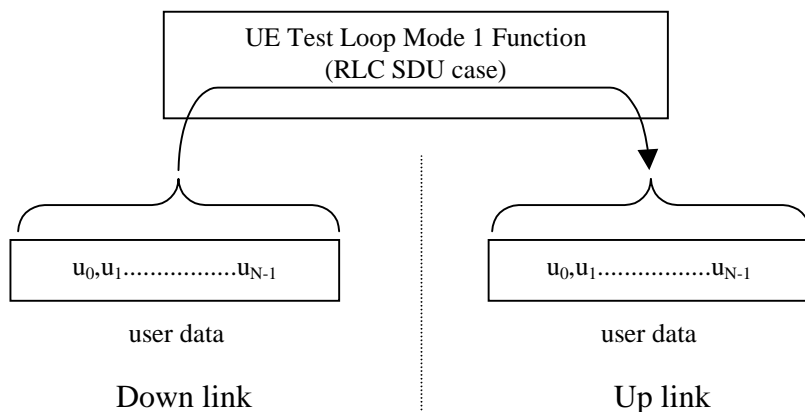

Figure 5.3.2.6.2.1: DL and UL RLC SDU block size equal (DL RLC SDU size = UL RLC SDU size = N)

For the case when the "UL RLC SDU size" parameter is set to a value less than the down link (DL) RLC SDU block size then the UE shall return the first K bits of the received block, where K is the UL block size, see figure 5.3.2.6.2.2.

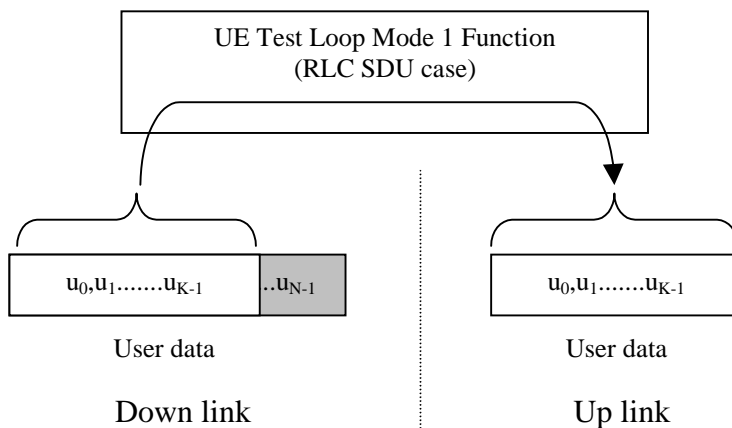

Figure 5.3.2.6.2.2: DL > UL RLC SDU block size (DL RLC SDU size = N, UL RLC SDU size = K)

For the case when the "UL RLC SDU size" parameter is set to a value bigger than the down link (DL) RLC SDU block size then the UE shall pad the UL send block by repeating the received data block until the UL send block has been filled (truncating the last block if necessary), see figure 5.3.2.6.2.3.

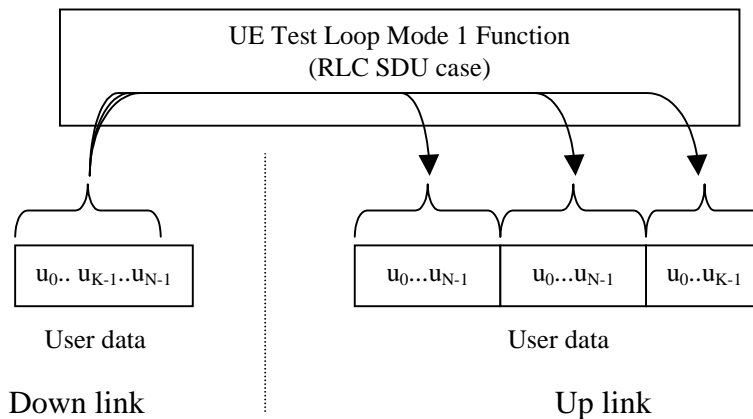

Figure 5.3.2.6.2.3: DL < UL RLC SDU block size (DL RLC SDU size = N, UL RLC SDU size = 2*N + K)

5.3.2.7 UE test loop mode 2 operation

For UE test loop mode 2 to work correctly ciphering shall be disabled.

For UE to be able to return downlink transport block data and CRC bits then the up link transport channel configuration shall include a transport format for which the block size is equal or bigger than the sum of the downlink transport block size and the number of downlink CRC bits. If no such uplink transport format exists then the returned data and CRC bits will be truncated.

5.3.2.7.1 Loopback of downlink transport block data and downlink CRC

If UE test mode 2 has been selected then the following loop back scheme shall be performed by the UE for all transport channels associated with a single DTCH:

After the UE has closed the test loop then the UE shall copy the received downlink transport block and CRC bits to the up link transport block and transmit in the up link.

If the uplink radio bearer configuration is of variable rate then the transport format with the smallest transport block size which fits the downlink transport block size and the downlink CRC bits shall be selected in uplink. In case there is no transport format that fits the downlink transport block data and the downlink CRC bits then the data and CRC bits shall be truncated using the transport format with the biggest transport block size.

UE test mode 2 operation is illustrated for the case when uplink transport block size is bigger than the sum of downlink transport block size and size of downlink CRC in figure 5.3.2.7.1.

UE test mode 2 operation is illustrated for the case when uplink transport block size is smaller than the sum of downlink transport block size and size of downlink CRC in figure 5.3.2.7.2.

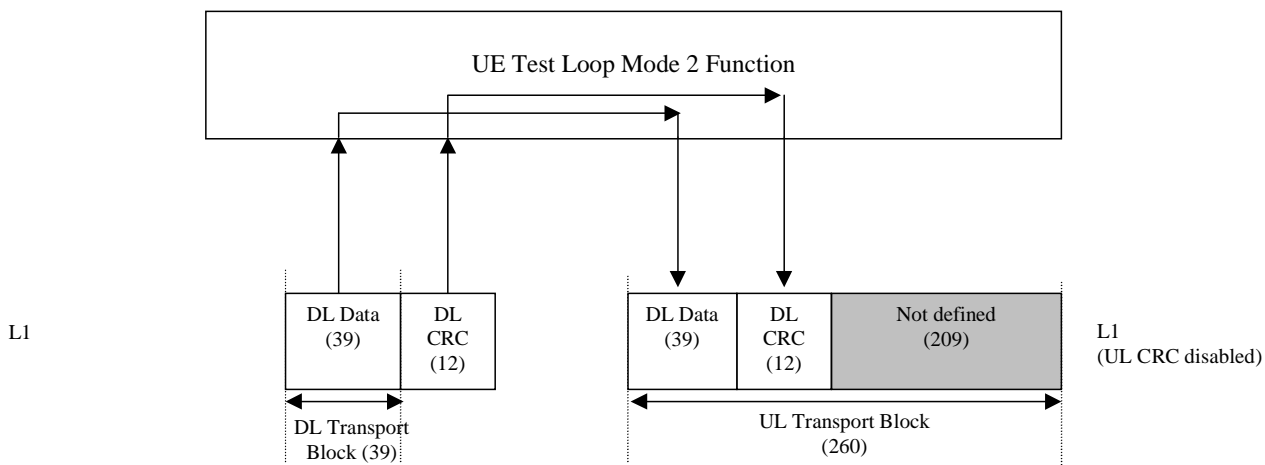

Figure 5.3.2.7.1. UE test loop mode 2 operation for the case when uplink transport block size is bigger than the sum of downlink transport block size and size of downlink CRC

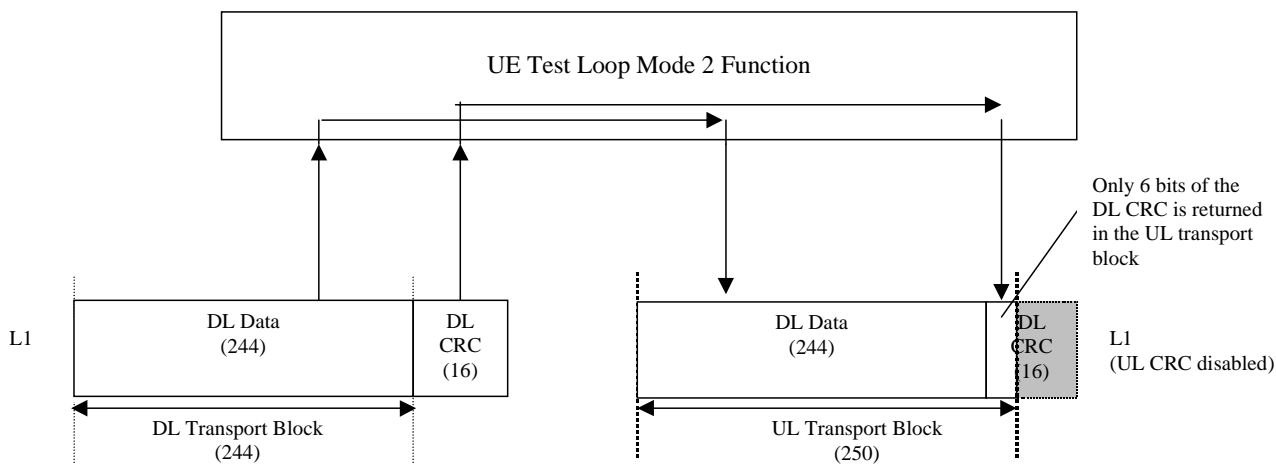

Figure 5.3.2.7.2. UE test loop mode 2 operation for the case when uplink transport block does not fit downlink transport block and downlink CRC bits.

5.3.2.8 Void

5.3.2.9 Loopback delay requirement

5.3.2.9.1 General loopback delay requirement

Loopback delay is specified as delay between received DL radio frames and their corresponding UL radio frames produced from the received data. The loopback delay is measured at the antenna connector of the UE and specified in the unit of radio frame(s). Timing offset between DL and UL radio frames, and timing errors are not included in the loopback delay.

For UE operating in UE test loop mode 1 the loopback delay requirement is applicable if the MAC and RLC protocols are configured for transparent operation and if the downlink RLC SDU size is equal to the downlink transport block size, i.e. no segmentation/concatenation takes place.

For UE operating in UE test loop mode 2 the loopback delay requirement is applicable independent of the radio bearer configuration.

While the UE test loop is closed and the radio bearer configuration is not changed, the UE shall maintain a fixed loopback delay (the loopback delay shall not vary during a test). The loopback delay shall not exceed the number of radio frames correspondent to 10 times the TTI of the actual transport channel configuration.

The loopback delay requirement for the 10ms TTI case is illustrated in figure 5.3.2.9.1.

NOTE 1: See TS 25.211 [11], subclause 7.6.3 for definition of the timing offset between DL and UL radio frames for FDD mode.

NOTE 2: See TS 25.133 [12], subclause 7.1 for definition of the timing error for FDD mode.

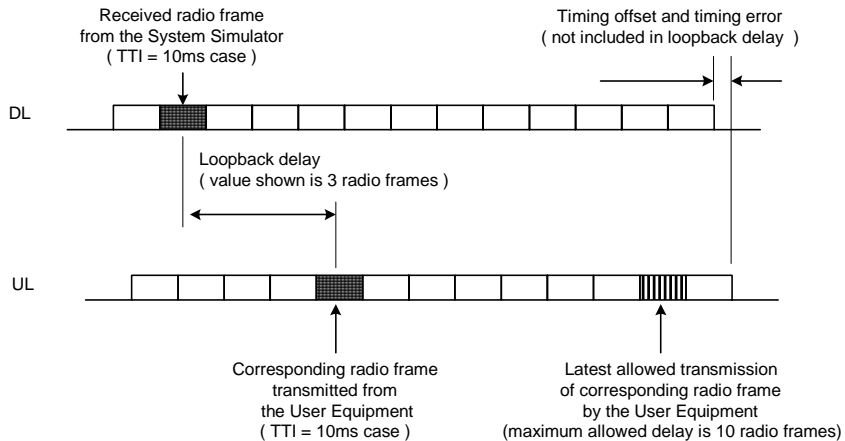

Figure 5.3.2.9.1: Loopback delay requirement (TTI=10 ms)

5.3.2.9.2 Loopback delay requirement for RLC and PDCP SDUs (UE Test loop mode 1)

The maximum delay from receiving an RLC or PDCP SDU in a downlink SAP until returning an SDU in the correspondent uplink SAP shall be within the delay requirement specified in subclause 5.3.2.9.1.

The UE test loop function, operating in UE test loop mode 1, shall for every active radio bearer be able to return at least 4 SDUs within the time equal to the TTI of the actual radio bearer.

NOTE: To enable testing of the Conversational CS TM reference radio bearer combinations as specified in 34.108 subclause 6.10 a UE must be able to loop back 4 SDUs per TTI. E.g. for "Conversational / unknown / UL:64 DL:64 kbps / CS RAB" operated in TM RLC mode 4 SDUs are needed to fill the transport format existing of 4x640 bits.

NOTE: The loopback delay requirement in 5.3.2.9.2 does not impose any synchronisation mechanisms between the uplink RLC entity and the UE test loop function. Thus it could happen that a UE when having received 4 SDUs within one and the same TTI may deliver the SDUs to the uplink RLC entity in two subsequent TTIs. For a TM radio bearer requiring multiple SDUs to fill a transport block set then "Timer discard without explicit signalling" needs to be configured to secure that the TM RLC entity does not discard the SDUs in case they are delivered in subsequent TTIs.

5.3.3 Open UE test loop

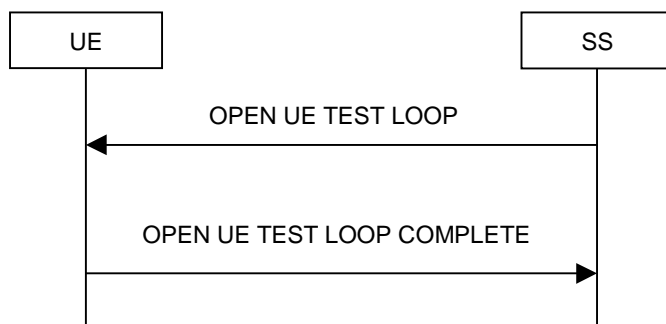

Figure 5.3.3.1: Open UE test loop procedure

5.3.3.1 General

The SS uses the procedure open UE test loop to deactivate the UE test loop function in the UE.

5.3.3.2 Initiation

The SS requests the UE to open its radio bearer test loop by transmitting an OPEN_UE_TEST_LOOP_CMD message. The SS then starts timer TT01.

5.3.3.3 Reception of OPEN UE TEST LOOP message by the UE

If no radio bearer is established, the UE shall ignore any OPEN UE TEST LOOP message.

If a radio bearer is established, the UE shall open the test loop and send back to the SS an OPEN UE TEST LOOP COMPLETE message.

If the test loop is already open, the UE shall still respond as if the loop had been closed, i.e. the OPEN UE TEST LOOP COMPLETE message should be sent prior to TT01 expiring.

5.3.3.4 Reception of OPEN UE TEST LOOP COMPLETE by the SS

Upon reception of the OPEN UE TEST LOOP COMPLETE message the SS stops timer TT01.

5.3.3.5 TT01 timeout

If TT01 expires, then the SS shall indicate this to the test case. The procedure is then completed.

5.4 UE Positioning test mode procedures

5.4.1 Reset UE Positioning Stored Information

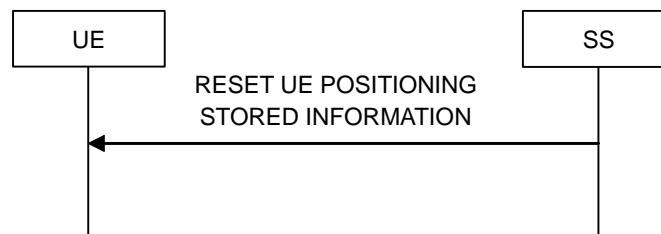

5.4.1.1 General

The SS uses the reset UE positioning stored information procedure to command the UE to reset the already acquired UE POSITIONING information in preparation for subsequent test procedures.

5.4.1.2 Initiation

The SS requests the UE to reset the stored UE positioning information mode by transmitting a RESET UE POSITIONING STORED INFORMATION message.

5.4.1.3 Reception of RESET UE POSITIONING STORED INFORMATION message by UE

When UE receives RESET UE POSITIONING STORED INFORMATION message then the UE shall:

- 1> if the IE "UE Positioning Technology" has the value "AGPS":

2> discard any stored GPS reference time, reference position, and any other aiding data obtained or derived during the previous test instance (e.g. expected ranges and Doppler).

1> otherwise:

2> ignore the message.

6 Message definitions and contents

In this clause, only TC protocol messages are described. TC control messages are intended to be sent using the RRC downlink and uplink direct transfer procedures, see TS 25.331 [5], subclause 8.1.9 and subclause 8.1.10.

NOTE 1: A message received with skip indicator different from 0 will be ignored.

NOTE 2: For general definition of Layer 3 message format see TS 24.007 [1], clause 11.

NOTE 3: GSM and 3G test messages uses the same protocol discriminator value ("1111"). Following message type value series are reserved for GSM testing commands as specified by TS 44.014 [13]: 0000xxxx, 0001xxxx and 0010xxxx where x represent 0 or 1. For 3G test commands the message type value series 0100xxxx is reserved.

6.1 Timer values

TT01: Recommended value: 2,5 seconds.

6.2 CLOSE UE TEST LOOP

This message is only sent in the direction SS to UE.

Information Element	Reference	Presence	Format	Length
Protocol discriminator	TS 24.007 [1], subclause 11.2.3.1.1	M	V	½
Skip indicator	TS 24.007 [1], subclause 11.2.3.1.2	M	V	½
Message type		M	V	1
UE test loop mode		M	V	1
UE test loop mode 1 LB setup		C	LV	1-16

where message type is:

8	7	6	5	4	3	2	1	bit no.
0	1	0	0	0	0	0	0	octet 1

where UE test loop mode is:

8	7	6	5	4	3	2	1	bit no.
0	0	0	0	0	0	X2	X1	octet 1

X2=0 and X1=0 then UE test loop mode 1 loop back scheme according to 5.3.2.6 shall be performed by the UE (loopback of RLC SDUs or PDCP SDUs).

X2=0 and X1=1 then UE test loop mode 2 loop back scheme according to 5.3.2.7 shall be performed by the UE (loopback of transport block data and CRC bits).

For backward compatibility reason, the bit 3 of octet 1 shall not be used and shall always be set to zero.

where UE test loop mode 1 LB setup is:

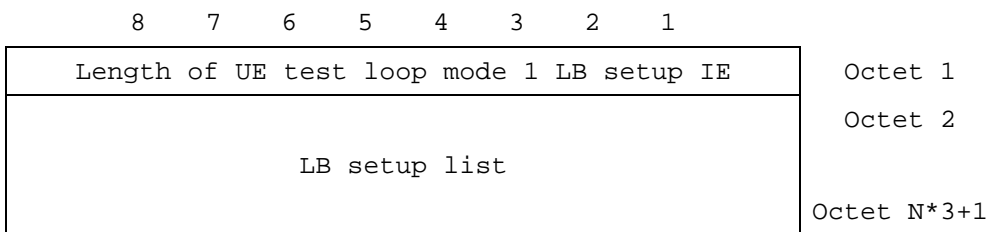

N is the number of LB entities in the LB setup list and is less than or equal to 5.

where LB setup list is:

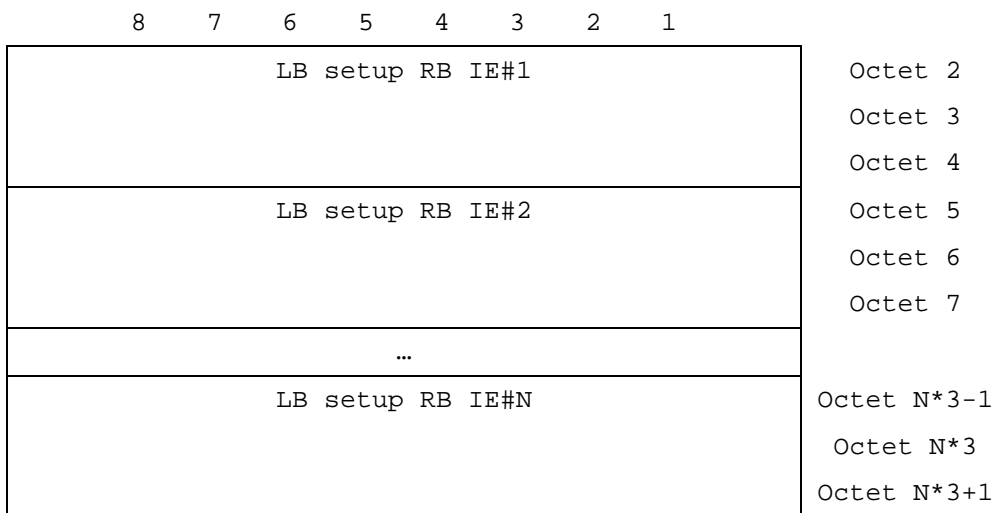

where LB Setup RB IE#k is:

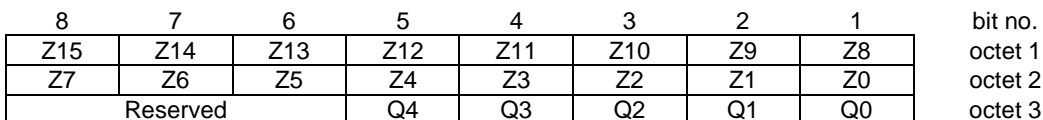

Z15..Z0 = Uplink RLC SDU size in bits 0.. 65535 (binary coded, Z15 is most significant bit and Z0 least significant bit), see Note 1.

Q4..Q0 = RB identity number, 5..32 (binary coded, Q4 is most significant bit and Q0 least significant bit), where RB identity identifies the radio bearer, see [5] TS 25.331. The range is limited to 5..32 due to RB0 to RB4 are reserved for signalling radio bearers.

NOTE: The parameter UL RLC SDU size is only applicable for UE test loop mode 1 and for radio bearers not using the PDCP protocol layer, see subclause 5.3.2.6.2. The UE capability for the parameter UL RLC SDU size is stated by the UE manufacturer as an Implementation Conformations Statement (ICS) as defined in TS 34.123-2 [17], subclause A.4.3.1 table A.13. The UE Total RLC AM buffer size according to the UE Radio Access Capabilities defined in TS 25.306 [18] shall not be exceeded.

6.3 CLOSE UE TEST LOOP COMPLETE

This message is only sent in the direction UE to SS.

Information Element	Reference	Presence	Format	Length
Protocol discriminator	TS 24.007 [1], subclause 11.2.3.1.1	M	V	1/2
Skip indicator	TS 24.007 [1], subclause 11.2.3.1.2	M	V	1/2
Message type		M	V	1

where message type is:

8	7	6	5	4	3	2	1	bit no.
0	1	0	0	0	0	0	1	Octet 1

6.4 OPEN UE TEST LOOP

This message is only sent in the direction SS to UE

Information Element	Reference	Presence	Format	Length
Protocol discriminator	TS 24.007 [1], subclause 11.2.3.1.1	M	V	1/2
Skip indicator	TS 24.007 [1], subclause 11.2.3.1.2	M	V	1/2
Message type		M	V	1

where message type is:

8	7	6	5	4	3	2	1	Bit no.
0	1	0	0	0	0	1	0	Octet 1

6.5 OPEN UE TEST LOOP COMPLETE

This message is only sent in the direction UE to SS.

Information Element	Reference	Presence	Format	Length
Protocol discriminator	TS 24.007 [1], subclause 11.2.3.1.1	M	V	1/2
Skip indicator	TS 24.007 [1], subclause 11.2.3.1.2	M	V	1/2
Message type		M	V	1

where message type is:

8	7	6	5	4	3	2	1	bit no.
0	1	0	0	0	0	1	1	Octet 1

6.6 ACTIVATE RB TEST MODE

This message is only sent in the direction SS to UE.

Information Element	Reference	Presence	Format	Length
Protocol discriminator	TS 24.007 [1], subclause 11.2.3.1.1	M	V	1/2
Skip indicator	TS 24.007 [1], subclause 11.2.3.1.2	M	V	1/2
Message type		M	V	1

where message type is:

8	7	6	5	4	3	2	1	bit no.
0	1	0	0	0	1	0	0	octet 1

6.7 ACTIVATE RB TEST MODE COMPLETE

This message is only sent in the direction UE to SS.

Information Element	Reference	Presence	Format	Length
Protocol discriminator	TS 24.007 [1], subclause 11.2.3.1.1	M	V	½
Skip indicator	TS 24.007 [1], subclause 11.2.3.1.2	M	V	½
Message type		M	V	1

where message type is:

8	7	6	5	4	3	2	1	bit no.
0	1	0	0	0	1	0	1	octet 1

6.8 DEACTIVATE RB TEST MODE

This message is only sent in the direction SS to UE.

Information Element	Reference	Presence	Format	Length
Protocol discriminator	TS 24.007 [1], subclause 11.2.3.1.1	M	V	½
Skip indicator	TS 24.007 [1], subclause 11.2.3.1.2	M	V	½
Message type		M	V	1

where message type is:

8	7	6	5	4	3	2	1	bit no.
0	1	0	0	0	1	1	0	octet 1

6.9 DEACTIVATE RB TEST MODE COMPLETE

This message is only sent in the direction UE to SS.

Information Element	Reference	Presence	Format	Length
Protocol discriminator	TS 24.007 [1], subclause 11.2.3.1.1	M	V	½
Skip indicator	TS 24.007 [1], subclause 11.2.3.1.2	M	V	½
Message type		M	V	1

where message type is:

8	7	6	5	4	3	2	1	bit no.
0	1	0	0	0	1	1	1	octet 1

6.10 RESET UE POSITIONING STORED INFORMATION

This message is only sent in the direction SS to UE.

Information Element	Reference	Presence	Format	Length
Protocol discriminator	TS 24.007 [1], subclause 11.2.3.1.1	M	V	1/2
Skip indicator	TS 24.007 [1], subclause 11.2.3.1.2	M	V	1/2
Message type		M	V	1
UE Positioning Technology		M	V	1

where message type is:

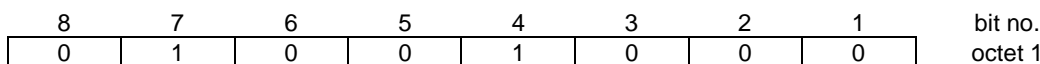

where UE positioning technology is a single octet IE:

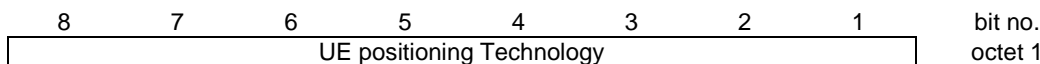

UE Positioning Technology value

Bits

8 7 6 5 4 3 2 1

0 0 0 0 0 0 0 0 AGPS

All other cause values are reserved for future use

7 Electrical Man Machine Interface (EMMI)

The EMMI is used for automation of conformance testing. The commands used on the EMMI by the System Simulator, shall be limited to the AT commands specified in TS 27.005 [15], TS 27.007 [16] and TS 27.060 [17]. The EMMI and its use for automation of signalling testing are illustrated in figure 7.1 as an example.

At the System Simulator side, a logical EMMI using AT commands shall interface with the TTCN test cases. A physical EMMI interface may be a standard RS232 interface towards the UE. Other interfaces shall not be precluded.

At the UE side the physical interface may be of various types, and an adapter may be provided by the UE manufacturer for converting the AT commands between the System Simulator interface into the UE manufacturer specific interface and format.

The use of EMMI is optional for the UE.

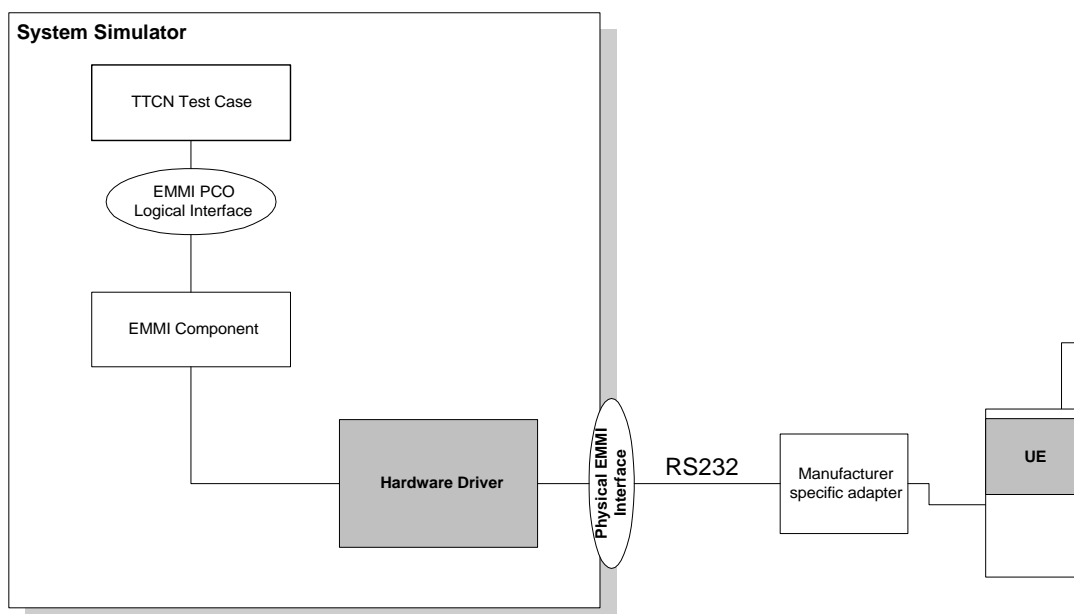

Figure 7.1: An example of EMMI and its use for automation of signalling testing

8 UICC/ME test interface

8.1 General description

A special interface is required in order to perform the tests of the UICC/ME interface.

8.2 Formal aspects

It shall be possible to connect the UICC/USIM simulator to the ME. If an adapter is to be used, the manufacturer of the ME shall provide it.

When using the UICC/USIM simulator, the ME does not necessarily conform to all RF requirements.

When the UICC/USIM simulator is connected the ME shall be able to correctly send and receive on a DTCH and associated channels under ideal radio conditions.

8.3 Hardware and logical aspects of the interface

The signals on this interface are specified in TS 31.101 [7].

8.4 Mechanical characteristics of the interface

The mechanical interface is specified in TS 31.101 [7].

Annex A (informative): UE test loop use scenarios

A.1 Measurement of receiver characteristics (BER) using UE test loop mode 1 and RLC TM

SS can use the UE test loop mode 1 and RLC TM for measuring BER. For UE to be able to return all data it receives from SS it is required that the DL and UL transport block size are the same. It is also required that the UL RLC SDU size parameter of the CLOSE UE TEST LOOP message is set to the same value as the DL and UL transport block size.

A.1.1 Measurement of receiver characteristics (BER) - DL reference measurement channel (12.2 kbps)

In FDD mode, for measuring BER for the DL and UL reference measurement channel 12.2 kbps according to TS 34.121 [8], Annex C the configuration should be:

- DL and UL transport block size = 244 bits (RLC TM);
- UE test loop mode 1 parameter UL RLC SDU size = 244 bits.

In TDD mode, for measuring BER for the DL and UL reference measurement channel 12.2 kbps according to TS 34.122 [9], Annex C.

A.2 Measurement of receiver performance (BLER) using UE test loop mode 1 and RLC AM

To measure BLER UE test loop mode 1 can be used by having the DL RLC protocol operating in acknowledged mode (AM). The SS can calculate BLER from the ratio of number of UE retransmission requests and the total number of blocks sent by the SS.

In AM the UE indicates missing protocol units (=transport blocks) in the STATUS PDU message. There are different triggers for sending the STATUS PDU message. For the purpose of SS BLER measurement a timer based trigger such as receiver timer based STATUS PDU transfer can be used (see TS 25.322, subclause 9.7.2). The figure below illustrates the SS BLER measurement procedure. In the example in the figure block errors are detected by the UE of a total of N blocks. The BLER calculated by the SS is $4 / N$.

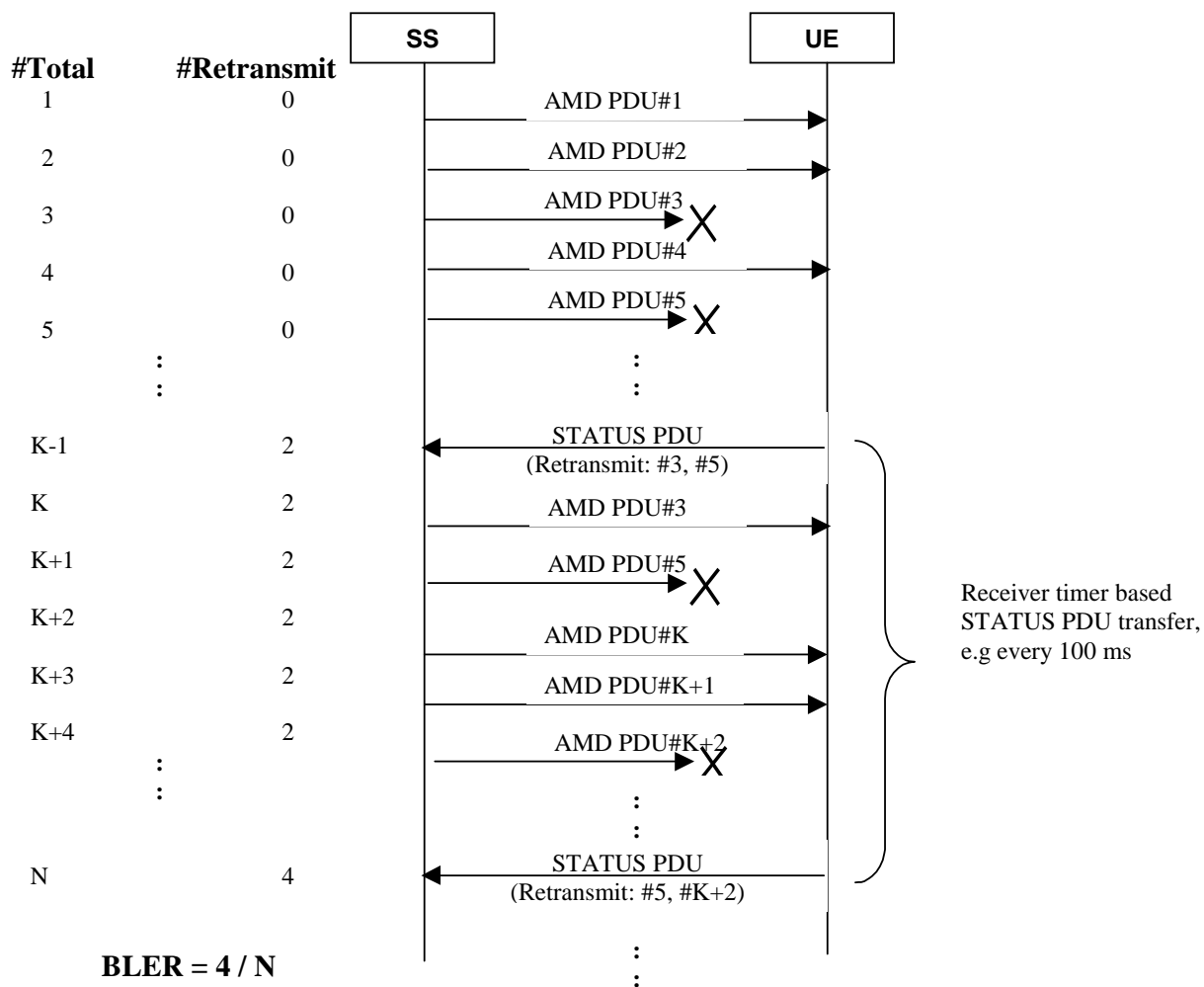

#Total = Number of sent blocks,
 #Retransmit = Number of UE retransmission requests

Figure A.2.1: Measuring BLER using UE test loop mode 1 and DL RLC AM

A.2.1 Measurement of receiver performance (BLER) - DL reference measurement channel (64,144,384 kbps)

By having downlink transport block size set to size of user data part according to the 64, 144 or 384 kbps reference measurement channels and using RLC acknowledge mode the UE test loop mode 1 can be used to measure BLER.

A.3 Measurement of receiver performance (BLER) using UE test loop mode 2

In addition to the method described in A.2 UE test loop mode 2 can be used to measure BLER if the UL transport block size is bigger or equal to the sum of DL transport block size and number of DL CRC bits.

The SS can calculate BLER by checking returned data and CRC and count number of block errors and the total number of sent blocks.

A.3.1 Measurement of receiver performance (BLER) - DL reference measurement channel (12.2 kbps)

TS 34.121 [8], subclauses C.2.1 and C.3.1 defines the DL and UL reference measurement channel 12.2 kbps for FDD mode.

TS 34.122 [9], subclauses C.2.1 and C.3.1 defines the DL and UL reference measurement channel 12.2 kbps for TDD mode.

To be able to measure BLER using UE test loop mode 2 the SS needs to configure the uplink transport block size to 260 bits to fit downlink transport block size (244 bits) and downlink CRC bits (16 bits), see figure A.3.1.

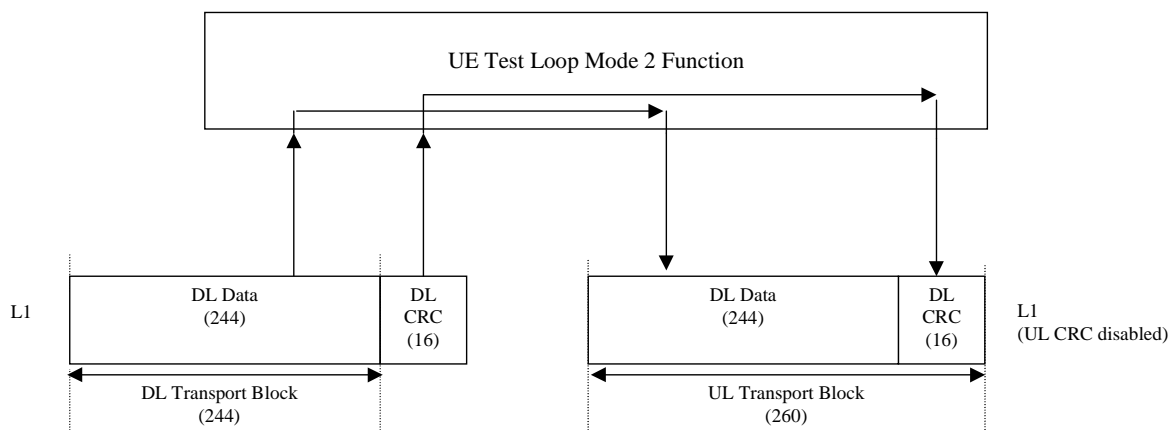

Figure A.3.1: UE test loop mode 2 operation for the 12.2 kbps BLER measurement case

A.3.2 Measurement of receiver performance (BLER) - DL reference measurement channel (64,144 and 384 kbps)

TS 34.121 [8], subclause C.2 defines the DL and UL reference measurement channel for 64, 144 and 384 kbps for FDD mode.

TS 34.122 [9], subclause C.2 defines the DL reference measurement channel for 64, 144 and 384 kbps for TDD mode.

If a UE supports downlink reference measurement channels for 64,144 or 384 kbps and also the correspondent uplink reference measurement channel then it is possible to use UE test loop mode 2 for measuring BLER for these reference measurement channels.

A.4 Measurement of transmitter characteristics

The SS sets up the radio bearer for DL and UL reference measurement channels 12.2 kbps using the generic setup procedure.

See TS 34.108 [10], clause 7 for specification of the generic setup procedure.

See TS 34.121 [8], subclauses C.2.1 and C.3.1 for definition of the DL and UL reference measurement channel 12.2 kbps for FDD mode.

See TS 34.122 [9], subclauses C.2.1 and C.2.2 for definition of the DL and UL reference measurement channel 12.2 kbps for TDD mode.

The SS orders the UE to close its UE test loop by transmitting a CLOSE UE TEST LOOP CMD message.

When the SS receives the CLOSE UE TEST LOOP COMPLETE message from the UE the SS starts transmission of data to the UE.

Perform the transmitter test.

The SS sends the OPEN UE TEST LOOP message to the UE to open the UE test loop.

A.5 Measurement of transmitter DTX characteristics

The SS requests the UE to enable DTX and sets up the radio bearer for DL and UL reference measurement channels 12.2 kbps using the generic setup procedure.

See TS 34.108 [10], clause 7 for specification of the generic setup procedure.

See TS 34.121 [8], subclauses C.2.1 and C.3.1 for definition of the DL and UL reference measurement channel 12.2 kbps for FDD mode.

See TS 34.122 [9], subclauses C.2.1 and C.2.2 for definition of the DL and UL reference measurement channel 12.2 kbps for TDD mode.

The SS orders the UE to close its UE test loop using UE test mode 1 by transmitting a CLOSE UE TEST LOOP message.

The UE confirms that the UE test loop is closed by sending the CLOSE UE TEST LOOP COMPLETE message to the SS.

Perform the transmitter DTX testing.

The SS sends the OPEN UE TEST LOOP message to the UE to open the UE test loop.

A.6 Using UE test loop mode 2 for testing of UE Blind Transport Format Detection (FDD mode)

When a UE operates in UE test loop mode 2 then the received downlink transport block and the downlink CRC data bits shall be returned in the uplink transport block, see subclause 5.3.2.7. The UE shall select the uplink transport format with the smallest transport block size, which fits both the received downlink transport block and the downlink CRC bits. Table A.6.1 gives an example of an uplink radio bearer configuration for variable rate having three transports formats TF0, TF1 and TF2. Table A.6.2 gives some examples of UE selected uplink transport format versus size of received downlink transport block and downlink CRC bits.

The SS can use UE test loop mode 2 for testing UE blind transport format detection by taken the possible downlink transport formats into consideration when configuring the uplink transport formats. I.e. for every downlink transport format there should be an uplink transport format for which the transport block size is equal to the sum of the downlink transport block size and the number of downlink CRC bits. Thus the SS can check the TFI of the UE transmitted transport format to verify that the UE has detected the correct downlink transport format. Table A.6.3 gives an example of a configuration for testing blind transport format detection using 9 possible downlink transport formats TF0 to TF8. The right hand column shows the minimum uplink transport block sizes the SS has to set-up to be able to test the UE blind transport format detection behaviour.

Table A.6.1: Uplink transport formats

UL transport format	Transport block size
TF0	0
TF1	55 bits
TF2	111 bits

Table A.6.2: Selected uplink transport format versus size of received downlink transport block and downlink CRC bits

DL transport block size	Number of DL CRC bits	Selected UL TF	Comment
39 bits	16 bits	TF1	39 + 16 = 55 i.e. TF1 ok
40 bits	16 bits	TF2	TF1 not possible (40 + 16 = 56 > 55) TF2 OK (56 < 111)
95 bits	16 bits	TF2	TF2 OK (95+16=111)
96 bits	16 bits	TF2	96 + 16 = 112 is bigger than TF2 block size but no bigger TF available i.e. TF2 is selected and returned DL data and CRC is truncated (one bit of the DL CRC is not returned)

Table A.6.3: Example of configuration for testing behaviour of UE blind transport format detection

DL TFI of DTCH		UL TFI of DTCH Minimum required UL transport block size if DL CRC size=12	
TF0	39 bits	TF0	51 bits (39 + 12)
TF1	95 bits	TF1	107 bits (95 + 12)
TF2	103 bits	TF2	115 bits (103 + 12)
TF3	118 bits	TF3	130 bits (118 + 12)
TF4	134 bits	TF4	146 bits (134 + 12)
TF5	148 bits	TF5	160 bits (148 + 12)
TF6	159 bits	TF6	171 bits (159 + 12)
TF7	204 bits	TF7	216 bits (204 + 12)
TF8	244 bits	TF8	256 bits (244 + 12)

A.7 Using UE test loop mode 1 for protocol testing

The parameter UL RLC SDU in CLOSE UE TEST LOOP message is used to control the behaviour of the UE test function behaviour regarding the uplink RLC SDU size.

In downlink the SS can control the downlink RLC SDU size by creating test data blocks of the size required for the test purpose.

Table A.7.1 describes the UE test function behaviour when operating in UE test loop mode 1 for different settings of DL and UL RLC SDU sizes:

Table A.7.1: UE test loop behaviour for different settings of DL and UL RLC SDU sizes.

UL RLC SDU size	UE test loop behaviour
= 0	Nothing is returned by UE in uplink
= DL RLC SDU size	All received data is returned by UE in uplink
< DL RLC SDU size	Received data is truncated by UE and sent in uplink
> DL RLC SDU size	Received data is repeated until UL RLC SDU block is filled and sent in uplink

Examples of different configurations are shown in figures A.7.1 and A.7.2.

Figure A.7.1 illustrates a configuration for testing of RLC reassemble and segmentation. SS sends DL RLC SDU block size > DL RLC PDU block size and have configured UL RLC SDU block size = DL RLC SDU size > UL RLC PDU block size.

NOTE: For this type of configuration the UE receiver buffer limitations need to be considered when designing the test.

Figure A.7.2 illustrates a configuration for BER measurements. SS sends DL RLC SDU block size = DL RLC PDU block size and have configured UL RLC SDU block size = UL RLC PDU block size = DL RLC PDU block size. RLC and MAC are configured for transparent mode.

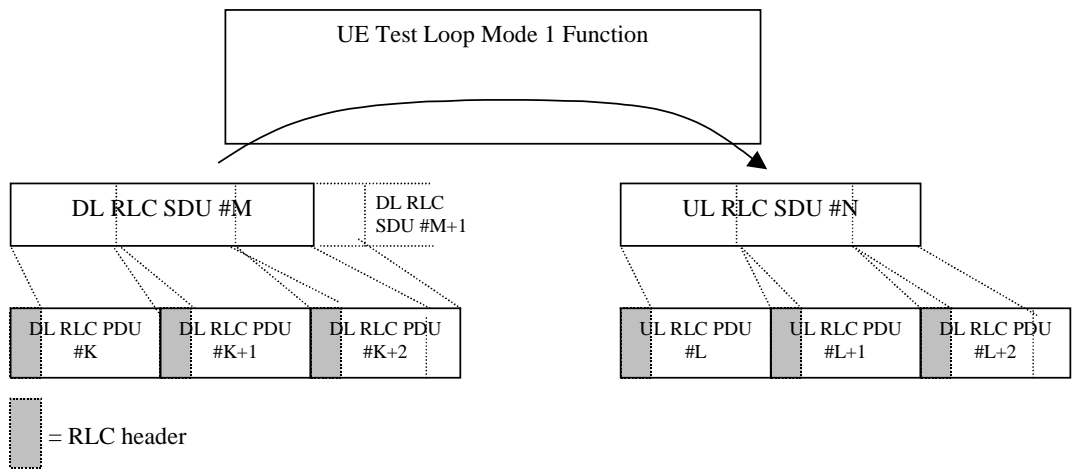

Figure A.7.1: Configuration for testing of RLC reassembly in downlink and RLC segmentation in uplink

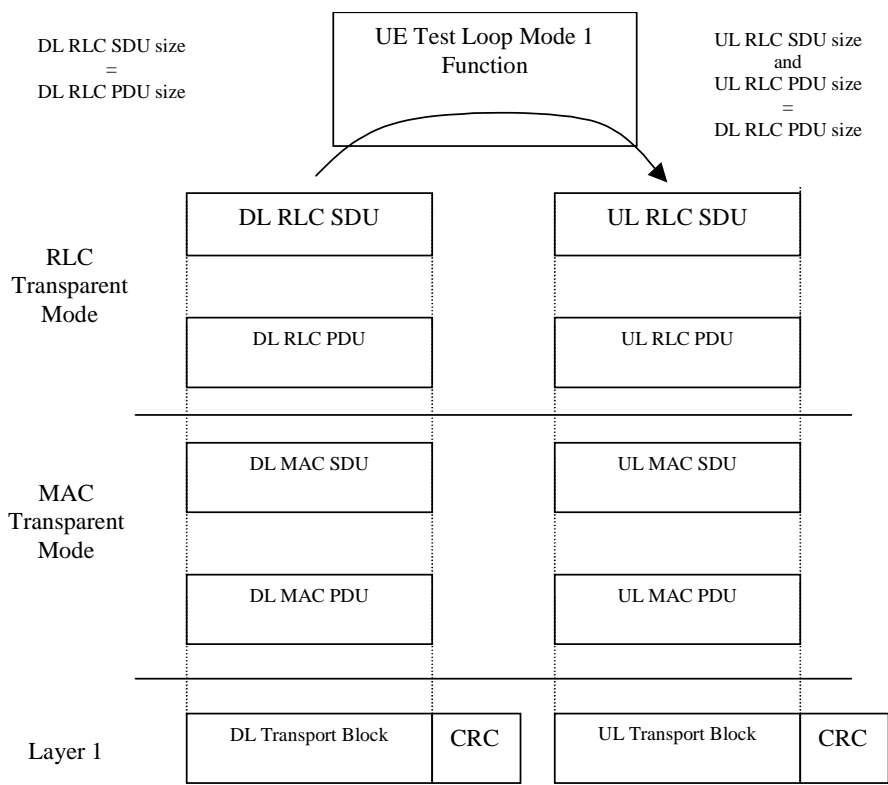

Figure A.7.2: Example of a configuration used for BER measurement

Annex B (informative): Change history

Change history							
Date	TSG #	TSG Doc.	CR	Rev	Subject/Comment	Old	New
06/2000	TP-08	-	-		Approved at TSG-T #8 and placed under Change Control	-	3.0.0
09/2000	TP-09	TP-000162	001		Clarification of UE test loop mode 2 loop back scheme	3.0.0	3.1.0
	TP-09	TP-000162	002		Clarification of loopback delay requirement	3.0.0	3.1.0
	TP-09	TP-000162	003		Change Request about specification TS 34.109	3.0.0	3.1.0
	TP-09	TP-000162	004		UE test loop mode 1, loopback of PDCP SDUs	3.0.0	3.1.0
11/2000	-	-	-		Handover of responsibility from TSG-T to TSG-RAN	-	-
12/2000	RP-10	RP-000579	005	1	Setting up UE test loop for multiple radio bearer configurations	3.1.0	3.2.0
03/2001	RP-11	RP-010036	006		Electrical Man Machine Interface	3.2.0	3.3.0
	RP-11	-	-		Upgrade to Release 4 - no technical change	3.3.0	4.0.0
06/2001	RP-12	RP-010319	008		Clarification to Loopback Delay requirement & BTFD in TDD mode	4.0.0	4.1.0
	RP-12	RP-010319	010		Expanding UE test loop buffering capabilities to enable testing of 2048 kbps radio bearers	4.0.0	4.1.0
03/2002	RP-15	RP-020077	012		Clarifications of UE conformance test functions	4.1.0	4.2.0
	RP-15	-	-		Upgrade to Release 5 - no technical change	4.2.0	5.0.0
06/2002	RP-16	RP-020338	015		Correction to UE test loop mode 2	5.0.0	5.1.0
	RP-16	RP-020338	018		Clarification of test loop performance requirements	5.0.0	5.1.0
12/2002	RP-18	RP-020728	022		Reference Measurement Channels references	5.1.0	5.2.0
03/2003	RP-19	RP-030162	025	1	Removal of uplink dummy DCCH transmission function in UE	5.2.0	5.3.0
09/2004	RP-25	RP-040329	029		UE test loop mode with PDCP configuration	5.3.0	5.4.0
	RP-25	RP-040329	033	1	Addition of RESET UE POSITIONING STORED INFORMATION message	5.3.0	5.4.0
	RP-25	RP-040337	034		Increase of maximum number of loopback entities	5.3.0	5.4.0
12/2004	RP-26	-	-		Upgrade to the Release 6. No technical change.	5.4.0	6.0.0

History

Document history		
V6.0.0	December 2004	Publication