

ETSI TS 134 121 V3.0.1 (2000-03)

Technical Specification

**Universal Mobile Telecommunications System (UMTS);
Technical Specification Group Terminals;
Terminal Conformance Specification, Radio Transmission and
Reception (FDD)
(3G TS 34.121 version 3.0.1 Release 1999)**



Reference

DTS/TSGT-0134121U

Keywords

UMTS

ETSI

650 Route des Lucioles
F-06921 Sophia Antipolis Cedex - FRANCE

Tel.: +33 4 92 94 42 00 Fax: +33 4 93 65 47 16

Siret N° 348 623 562 00017 - NAF 742 C
Association à but non lucratif enregistrée à la
Sous-Préfecture de Grasse (06) N° 7803/88

Important notice

Individual copies of the present document can be downloaded from:

<http://www.etsi.org>

The present document may be made available in more than one electronic version or in print. In any case of existing or perceived difference in contents between such versions, the reference version is the Portable Document Format (PDF).

In case of dispute, the reference shall be the printing on ETSI printers of the PDF version kept on a specific network drive within ETSI Secretariat.

Users of the present document should be aware that the document may be subject to revision or change of status.

Information on the current status of this and other ETSI documents is available at <http://www.etsi.org/tb/status/>

If you find errors in the present document, send your comment to:

editor@etsi.fr

Copyright Notification

No part may be reproduced except as authorized by written permission.
The copyright and the foregoing restriction extend to reproduction in all media.

© European Telecommunications Standards Institute 2000.

All rights reserved.

Intellectual Property Rights

IPRs essential or potentially essential to the present document may have been declared to ETSI. The information pertaining to these essential IPRs, if any, is publicly available for **ETSI members and non-members**, and can be found in SR 000 314: "*Intellectual Property Rights (IPRs); Essential, or potentially Essential, IPRs notified to ETSI in respect of ETSI standards*", which is available from the ETSI Secretariat. Latest updates are available on the ETSI Web server (<http://www.etsi.org/ipr>).

Pursuant to the ETSI IPR Policy, no investigation, including IPR searches, has been carried out by ETSI. No guarantee can be given as to the existence of other IPRs not referenced in SR 000 314 (or the updates on the ETSI Web server) which are, or may be, or may become, essential to the present document.

Foreword

This Technical Specification (TS) has been produced by the ETSI 3rd Generation Partnership Project (3GPP).

The present document may refer to technical specifications or reports using their 3GPP identities, UMTS identities or GSM identities. These should be interpreted as being references to the corresponding ETSI deliverables.

The cross reference between GSM, UMTS, 3GPP and ETSI identities can be found under www.etsi.org/key.

Contents

Foreword	11
1 Scope.....	12
2 References.....	12
3 Definitions, abbreviations and equations	12
3.1 Definitions	12
3.2 Abbreviations.....	13
3.3 Equations	13
4 Frequency bands and channel arrangement	13
4.1 General.....	13
4.2 Frequency bands	14
4.3 TX–RX frequency separation	14
4.4 Channel arrangement	14
4.4.1 Channel spacing	14
4.4.2 Channel raster.....	14
4.4.3 Channel number	14
5 Transmitter Characteristics	15
5.1 General.....	15
5.2 Maximum Output Power	15
5.2.1 Definition and applicability.....	15
5.2.2 Conformance requirements	16
5.2.3 Test purpose	16
5.2.4 Method of test	16
5.2.4.1 Initial conditions	16
5.2.4.2 Procedure.....	16
5.2.5 Test requirements	16
5.3 Frequency Stability	17
5.3.1 Definition and applicability.....	17
5.3.2 Conformance requirements	17
5.3.3 Test purpose	17
5.3.4 Method of test	17
5.3.4.1 Initial conditions	17
5.3.4.2 Procedure.....	17
5.3.5 Test requirements	17
5.4 Output Power Dynamics in the Uplink.....	18
5.4.1 Open Loop Power Control in the Uplink	18
5.4.1.1 Definition and applicability	18
5.4.1.2 Conformance requirements.....	18
5.4.1.3 Test purpose	18
5.4.1.4 Method of test.....	18
5.4.1.4.1 Initial conditions	18
5.4.1.4.2 Procedure	19
5.4.1.5 Test requirements	19
5.4.2 Inner Loop Power Control in the Uplink.....	19
5.4.2.1 Definition and applicability	19
5.4.2.2 Conformance requirements.....	19
5.4.2.3 Test purpose	20
5.4.2.4 Method of test.....	20
5.4.2.4.1 Initial conditions	20
5.4.2.4.2 Procedure	21
5.4.2.5 Test requirements	22
5.4.3 Minimum Output Power.....	23
5.4.3.1 Definition and applicability	23
5.4.3.2 Conformance requirements.....	23
5.4.3.3 Test purpose	23

5.4.3.4	Method of test.....	23
5.4.3.4.1	Initial conditions	23
5.4.3.4.2	Procedure	23
5.4.3.5	Test requirements	24
5.5	Transmit ON/OFF Power.....	24
5.5.1	Transmit OFF Power.....	24
5.5.1.1	Definition and applicability	24
5.5.1.2	Conformance requirements.....	24
5.5.1.3	Test purpose	24
5.5.1.4	Method of test.....	24
5.5.1.4.1	Initial conditions	24
5.5.1.4.2	Procedure	24
5.5.1.5	Test requirements	24
5.5.2	Transmit ON/OFF Time mask	25
5.5.2.1	Definition and applicability	25
5.5.2.2	Conformance requirements.....	25
5.5.2.3	Test purpose	25
5.5.2.4	Method of test.....	26
5.5.2.4.1	Initial conditions	26
5.5.2.4.2	Procedure	26
5.5.2.5	Test requirements	27
5.6	Change of TFC	27
5.6.1	Definition and applicability.....	27
5.6.2	Conformance requirements	27
5.6.3	Test purpose	29
5.6.4	Method of test	29
5.6.4.1	Initial conditions.....	29
5.6.4.2	Procedure.....	29
5.6.5	Test requirements	29
5.7	Power setting in uplink compressed mode.....	29
5.7.1	Definition and applicability.....	29
5.7.2	Conformance requirements	29
5.7.3	Test purpose	31
5.7.4	Method of test	31
5.7.4.1	Initial conditions.....	31
5.7.4.2	Procedure.....	31
5.7.5	Test requirements	35
5.8	Occupied Bandwidth (OBW).....	37
5.8.1	Definition and applicability.....	37
5.8.2	Conformance requirements	37
5.8.3	Test purpose	37
5.8.4	Method of test	37
5.8.4.1	Initial conditions.....	37
5.8.4.2	Procedure.....	38
5.8.5	Test requirements	38
5.9	Spectrum emission mask	38
5.9.1	Definition and applicability.....	38
5.9.2	Conformance requirements	38
5.9.3	Test purpose	39
5.9.4	Method of test	39
5.9.4.1	Initial conditions.....	39
5.9.4.2	Procedure.....	39
5.9.5	Test requirements	39
5.10	Adjacent Channel Leakage Power Ratio (ACLR).....	39
5.10.1	Definition and applicability.....	39
5.10.2	Conformance requirements	40
5.10.3	Test purpose	40
5.10.4	Method of test	40
5.10.4.1	Initial conditions.....	40
5.10.4.2	Procedure.....	40
5.10.5	Test requirements	40
5.11	Spurious Emissions.....	41

5.11.1	Definition and applicability.....	41
5.11.2	Conformance requirements	41
5.11.3	Test purpose	41
5.11.4	Method of test	41
5.11.4.1	Initial conditions	41
5.11.4.2	Procedure.....	42
5.11.5	Test requirements	42
5.12	Transmit Intermodulation	42
5.12.1	Definition and applicability.....	42
5.12.2	Conformance requirements	42
5.12.3	Test purpose	42
5.12.4	Method of test	43
5.12.4.1	Initial conditions	43
5.12.4.2	Procedure.....	43
5.12.5	Test requirements	43
5.13	Transmit Modulation	43
5.13.1	Modulation Accuracy.....	43
5.13.1.1	Definition and applicability	43
5.13.1.2	Conformance requirements.....	43
5.13.1.3	Test purpose	44
5.13.1.4	Method of test.....	44
5.13.1.4.1	Initial conditions	44
5.13.1.4.2	Procedure	44
5.13.1.5	Test requirements	44
5.13.2	Peak code Domain error.....	44
5.13.2.1	Definition and applicability	44
5.13.2.2	Conformance requirements.....	44
5.13.2.3	Test purpose	44
5.13.2.4	Method of test.....	45
5.13.2.4.1	Initial conditions	45
5.13.2.4.2	Procedure	45
5.13.2.5	Test requirements	45
6	Receiver Characteristics	45
6.1	General.....	45
6.2	Reference Sensitivity Level	46
6.2.1	Definition and applicability.....	46
6.2.2	Conformance requirements	46
6.2.3	Test purpose	46
6.2.4	Method of test	46
6.2.4.1	Initial conditions	46
6.2.4.2	Procedure.....	46
6.2.5	Test requirements	47
6.3	Maximum Input Level	47
6.3.1	Definition and applicability.....	47
6.3.2	Conformance requirements	47
6.3.3	Test purpose	47
6.3.4	Method of test	47
6.3.4.1	Initial conditions	47
6.3.4.2	Procedure.....	47
6.3.5	Test requirements	47
6.4	Adjacent Channel Selectivity (ACS)	48
6.4.1	Definition and applicability.....	48
6.4.2	Conformance requirements	48
6.4.3	Test purpose	48
6.4.4	Method of test	48
6.4.4.1	Initial conditions	48
6.4.4.2	Procedure.....	48
6.4.5	Test requirements	48
6.5	Blocking Characteristics	49
6.5.1	Definition and applicability.....	49
6.5.2	Conformance requirements	49

6.5.3	Test purpose	49
6.5.4	Method of test	49
6.5.4.1	Initial conditions	49
6.5.4.2	Procedure	50
6.5.5	Test requirements	50
6.6	Spurious Response	50
6.6.1	Definition and applicability	50
6.6.2	Conformance requirements	50
6.6.3	Test purpose	50
6.6.4	Method of test	51
6.6.4.1	Initial conditions	51
6.6.4.2	Procedure	51
6.6.5	Test requirements	51
6.7	Intermodulation Characteristics	51
6.7.1	Definition and applicability	51
6.7.2	Conformance requirements	51
6.7.3	Test purpose	51
6.7.4	Method of test	52
6.7.4.1	Initial conditions	52
6.7.4.2	Procedure	52
6.7.5	Test requirements	52
6.8	Spurious Emissions	52
6.8.1	Definition and applicability	52
6.8.2	Conformance requirements	52
6.8.3	Test purpose	53
6.8.4	Method of test	53
6.8.4.1	Initial conditions	53
6.8.4.2	Procedure	53
6.8.5	Test requirements	53
7	Performance requirements	53
7.1	General	53
7.1.1	Measurement Configurations	54
7.2	Demodulation in Static Propagation conditions	54
7.2.1	Demodulation of Dedicated Channel (DCH)	54
7.2.1.1	Definition and applicability	54
7.2.1.2	Conformance requirements	54
7.2.1.3	Test purpose	55
7.2.1.4	Method of test	55
7.2.1.4.1	Initial conditions	55
7.2.1.4.2	Procedures	55
7.2.1.5	Test requirements	55
7.3	Demodulation of DCH in Multi-path Fading Propagation conditions	55
7.3.1	Single Link Performance	55
7.3.1.1	Definition and applicability	55
7.3.1.2	Conformance requirements	56
7.3.1.3	Test purpose	57
7.3.1.4	Method of test	57
7.3.1.4.1	Initial conditions	57
7.3.1.4.2	Procedures	57
7.3.1.5	Test requirements	57
7.4	Demodulation of DCH in Moving Propagation conditions	57
7.4.1	Single Link Performance	57
7.4.1.1	Definition and applicability	57
7.4.1.2	Conformance requirements	58
7.4.1.3	Test purpose	58
7.4.1.4	Method of test	58
7.4.1.4.1	Initial conditions	58
7.4.1.4.2	Procedures	58
7.4.1.5	Test requirements	59
7.5	Demodulation of DCH in Birth-Death Propagation conditions	59
7.5.1	Single Link Performance	59

7.5.1.1	Definition and applicability	59
7.5.1.2	Conformance requirements.....	59
7.5.1.3	Test purpose	59
7.5.1.4	Method of test.....	60
7.5.1.4.1	Initial conditions	60
7.5.1.4.2	Procedures.....	60
7.5.1.5	Test requirements	60
7.6	Demodulation of DCH in Base Station Transmit diversity modes	60
7.6.1	Demodulation of DCH in open-loop transmit diversity mode	60
7.6.1.1	Definition and applicability	60
7.6.1.2	Conformance requirements.....	60
7.6.1.3	Test purpose	61
7.6.1.4	Method of test.....	61
7.6.1.4.1	Initial conditions	61
7.6.1.4.2	Procedure	61
7.6.1.5	Test Requirements	61
7.6.2	Demodulation of DCH in closed loop transmit diversity mode	61
7.6.2.1	Definition and applicability	61
7.6.2.2	Conformance requirements.....	61
7.6.2.3	Test purpose	62
7.6.2.4	Method of test.....	62
7.6.2.4.1	Initial conditions	62
7.6.2.4.2	Procedure	62
7.6.2.5	Test Requirements	62
7.6.3	Demodulation of DCH in Site Selection Diversity Transmission mode	62
7.6.3.1	Definition and applicability	62
7.6.3.2	Conformance requirements.....	63
7.6.3.3	Test purpose	63
7.6.3.4	Method of test.....	64
7.6.3.4.1	Initial conditions	64
7.6.3.4.2	Procedure	64
7.6.3.5	Test Requirements	64
7.7	Demodulation in Handover conditions	64
7.7.1	Inter-Cell Soft Handover Performance.....	64
7.7.1.1	Definition and applicability	64
7.7.1.2	Conformance requirements.....	64
7.7.1.3	Test purpose	65
7.7.1.4	Method of test.....	65
7.7.1.4.1	Initial conditions	65
7.7.1.4.2	Procedures.....	65
7.7.1.5	Test requirements	65
7.8	Inner loop power control in downlink.....	65
7.8.1	Definition and applicability.....	65
7.8.2	Conformance requirements	66
7.8.3	Test purpose	66
7.8.4	Method of test	66
7.8.4.1	Initial conditions	66
7.8.4.2	Procedure.....	66
7.8.5	Test Requirements.....	67
7.9	Outer loop power control in downlink	67
7.9.1	Definition and applicability.....	67
7.9.2	Conformance requirements	67
7.9.3	Test purpose	68
7.9.4	Method of test	68
7.9.4.1	Initial conditions	68
7.9.4.2	Procedure.....	68
7.9.5	Test Requirements.....	68
7.10	Downlink compressed mode.....	68
7.10.1	Single link performance	68
7.10.1.1	Definition and applicability	68
7.10.1.2	Conformance requirements.....	68
7.10.1.3	Test purpose	69

7.10.1.4	Method of test.....	69
7.10.1.4.1	Initial conditions	69
7.10.1.4.2	Procedure	69
7.10.1.5	Test requirements	69
8	Requirements for support of RRM	70
8.1	General.....	70
8.2	Idle Mode Tasks	70
8.2.1	Introduction.....	70
8.2.2	RF Cell Selection Scenario	70
8.2.2.1	Requirements for Cell Selection Single carrier Single cell case.....	70
8.2.2.1.1	Cell Selection delay	70
8.2.2.1.2	Test Parameters.....	70
8.2.2.1.3	Performance Requirements	70
8.2.2.2	Requirements for Cell Selection multi carrier multi cell case	70
8.2.2.2.1	Cell selection delay	70
8.2.2.2.2	Test Parameters.....	70
8.2.2.2.3	Performance Requirements	70
8.2.3	RF Cell Re-Selection Scenario.....	70
8.2.3.1	Requirements for Cell Re-Selection single carrier multi cell case	70
8.2.3.1.1	Cell re-selection delay.....	70
8.2.3.1.2	Test Parameters.....	70
8.2.3.1.3	Performance Requirements	70
8.2.3.1.4	Cell List Size.....	70
8.2.3.1.5	Maximum number of cells to be monitored	70
8.2.4	PLMN Selection and Re-Selection Scenario.....	70
8.2.5	Location Registration Scenario	70
8.3	RRC Connection mobility.....	70
8.3.1	Handover.....	70
8.3.1.1	Introduction	71
8.3.1.2	Handover 3G to 3G	71
8.3.1.2.1	FDD Soft/Softer Handover	71
8.3.1.2.2	FDD Hard Handover.....	71
8.3.1.2.3	FDD/TDD Handover	71
8.3.1.3	Handover 3G to 2G	71
8.3.1.3.1	Handover to GSM.....	71
8.3.2	Radio Link Management.....	71
8.3.2.1	Link adaptation.....	72
8.3.2.1.1	Definition of the function.....	72
8.3.2.1.2	Link adaptation delay minimum requirement	72
8.3.2.1.3	Link adaptation maximum delay requirement	72
8.3.3	Cell Update	72
8.3.4	URA Update.....	72
8.4	RRC Connection Control.....	72
8.4.1	Requirements for RRC Re-establishment	72
8.4.1.1	RRC Re-establishment delay.....	72
8.4.1.2	Test Parameters	72
8.4.1.2.1	Test 1 - Target Cell known by UE	72
8.4.1.2.2	Test 2 - Target cell not known by UE.....	72
8.4.1.2.3	Performance Requirements	72
8.4.2	Radio Access Bearer Control	72
8.5	Radio Link Surveillance	72
8.6	Timing characteristics.....	72
8.6.1	Synchronization performance.....	72
8.6.1.1	Search of other Cells.....	72
8.6.1.1.1	Definition and applicability	72
8.6.1.1.2	Conformance requirements	72
8.6.1.1.3	Test purpose.....	73
8.6.1.1.4	Method of test	73
8.6.1.1.5	Test requirements.....	73
8.6.2	UE Transmit Timing	73

8.6.2.1	Initial transmission timing, Maximum timing adjustment size and Maximum timing adjustment rate	73
8.6.2.1.1	Definition and applicability	73
8.6.2.1.2	Conformance requirements	74
8.6.2.1.3	Test purpose	74
8.6.2.1.4	Method of test	74
8.6.2.1.5	Test requirements	74
8.6.3	Reception Timing	74
8.6.3.1	Definition and applicability	74
8.6.3.2	Conformance requirements	74
8.6.3.3	Test purpose	75
8.6.3.4	Method of test	75
8.6.3.4.1	Initial conditions	75
8.6.3.4.2	Procedures	75
8.6.3.5	Test requirements	75
8.6.4	Signalling requirements	76
8.6.4.1	Signalling response delay	76
8.6.4.2	Test Parameters	76
8.6.4.3	Performance requirements	76
8.6.4.4	Signalling processing	76
8.6.4.5	Test parameters	76
8.6.4.6	Performance requirements	76
8.7	Measurements Performance Requirements	76
8.7.1	CPICH RSCP	76
8.7.2	RSCP	76
8.7.3	SIR	76
8.7.4	UTRA carrier RSSI	76
8.7.5	GSM carrier RSSI	76
8.7.6	CPICH Ec/No	76
8.7.7	Transport channel BLER	76
8.7.8	Physical channel BER	76
8.7.9	UE transmitted power	76
8.7.10	CFN-SFN observed time difference	76
8.7.11	SFN-SFN observed time difference	76
8.7.12	UE Rx-Tx time difference	76
8.7.13	Observed time difference to GSM cell	76
Annex A (informative): Connection Diagrams		77
Annex B (normative): Global In-Channel TX-Test		81
B.1	General	81
B.2	Definition of the process	81
B.2.1	Basic principle	81
B.2.2	Output signal of the Tx under test	81
B.2.3	Reference signal	82
B.2.4	Provisions in case of multi code signals	82
B.2.5	Classification of measurement results	82
B.2.6	Process definition to achieve results of type 1	82
B.2.7	Process definition to achieve results of type 2	83
B.2.7.1	Error Vector Magnitude	83
B.2.7.2	Peak Code Domain Error	83
B.3	Application	84
Annex C (normative): Measurement channels		85
C.1	General	85
C.2	UL reference measurement channel	85
C.2.1	UL reference measurement channel (12.2 kbps)	85
C.2.2	UL reference measurement channel (64 kbps)	86
C.2.3	UL reference measurement channel (144 kbps)	87

C.2.4	UL reference measurement channel (384 kbps)	88
C.3	DL reference measurement channel.....	89
C.3.1	DL reference measurement channel (12,2 kbps)	89
C.3.2	DL reference measurement channel (64 kbps)	90
C.3.3	DL reference measurement channel (144 kbps)	91
C.3.4	DL reference measurement channel (384 kbps)	92
C.4	DL reference compressed mode parameters	93
Annex D (normative): Propagation Conditions		94
D.1	General.....	94
D.2	Propagation Conditions.....	94
D.2.1	Static propagation condition	94
D.2.2	Multi-path fading propagation conditions.....	94
D.2.3	Moving propagation conditions	94
D.2.4	Birth-Death propagation conditions.....	95
Annex E (normative): Downlink Physical Channels		96
E.1	General.....	96
E.2	Connection Set-up.....	96
E.3	During connection.....	96
E.3.1	Measurement of Tx Characteristics	96
E.3.2	Measurement of Rx Characteristics	96
E.3.3	Measurement of Performance requirements	97
E.3.4	Connection with open-loop transmit diversity mode.....	97
E.3.5	Connection with closed loop transmit diversity mode.....	98
Annex F (normative): Requirement of Test Equipment.....		99
Annex G (normative): Environmental conditions.....		100
G.1	General.....	100
G.2	Environmental requirements.....	100
G.2.1	Temperature	100
G.2.2	Voltage.....	100
G.2.3	Vibration.....	101
Annex H (normative): UE Capabilities (FDD)		102
H.1	Radio Access and RF Baseline Implementation Capabilities:.....	102
H.2	Service Implementation Capabilities:	102
Annex I (informative): Open Items		103
	Change History	106

Foreword

This Technical Specification (TS) has been produced by the 3rd Generation Partnership Project (3GPP).

The contents of the present document are subject to continuing work within the TSG and may change following formal TSG approval. Should the TSG modify the contents of the present document, it will be re-released by the TSG with an identifying change of release date and an increase in version number as follows:

Version x.y.z

where:

- x the first digit:
 - 1 presented to TSG for information;
 - 2 presented to TSG for approval;
 - 3 or greater indicates TSG approved document under change control.
- y the second digit is incremented for all changes of substance, i.e. technical enhancements, corrections, updates, etc.
- z the third digit is incremented when editorial only changes have been incorporated in the document.

1 Scope

The present document specifies the measurement procedures for the conformance test of the user equipment (UE) that contain transmitting characteristics, receiving characteristics and performance requirements in FDD mode.

2 References

The following documents contain provisions which, through reference in this text, constitute provisions of the present document.

- References are either specific (identified by date of publication, edition number, version number, etc.) or non-specific.
- For a specific reference, subsequent revisions do not apply.
- For a non-specific reference, the latest version applies.

- [1] 3GPP TS 25.101 "UE Radio transmission and reception (FDD)" V3.1.0*.
- [2] 3GPP TS 25.133 "Requirements for Support of Radio Resource Management (FDD)" V3.0.0*.
- [3] 3GPP TS 34.108 "Common Test Environments for User Equipment (UE) Conformance Testing".
- [4] 3GPP TS 34.109 "Logical Test Interface; Special conformance testing functions".
- [5] 3GPP TS 25.214 "Physical layer procedures (FDD)".
- [6] 3GPP TR 21.905 "Vocabulary for 3GPP Specifications".
- [7] 3GPP TR 25.990 "Vocabulary".

< *Editor's Note: The version numbers of the referred core documents are attached in order to avoid the confusion of readers. They will be removed in future because they are not permanent. >

3 Definitions, abbreviations and equations

Definitions, symbols, abbreviations and equations used in the present document are listed in TR 21.905 [5] and TR 25.990 [6].

Terms are listed in alphabetical order in this clause.

3.1 Definitions

For the purpose of the present document, the following additional terms and definitions apply:

Average power: [TBD]

Maximum average power: average transmitter output power obtained over any specified time interval, including periods with no transmission, when the transmit time slots are at the maximum power setting

3.2 Abbreviations

For the purpose of the present document, the following additional abbreviations apply:

AFC:	Automatic Frequency Control
ATT:	Attenuator
EVM:	Error Vector Magnitude
HYB:	Hybrid
OBW:	Occupied Bandwidth
OCNS:	Orthogonal Channel Noise Simulator, a mechanism used to simulate the users or control signals on the other orthogonal channels of a downlink
RRC:	Root-Raised Cosine
SS:	System Simulator

3.3 Equations

For the purpose of the present document, the following additional equations apply:

$\frac{CPICH_E_c}{I_{or}}$ The ratio of the received energy per PN chip of the CPICH to the total transmit power spectral density at the BS (SS) antenna connector.

F_{uw} Frequency of unwanted signal. This is specified in bracket in terms of an absolute frequency(s) or a frequency offset from the assigned channel frequency.

I_{BTS} Interference signal power level at BTS in dBm, which is broadcasted on BCH.

I_{oac} The power spectral density of the adjacent frequency channel as measured at the UE antenna connector.

$\frac{PICH_E_c}{I_{or}}$ The ratio of the received energy per PN chip of the PICH to the total transmit power spectral density at the BS (SS) antenna connector.

4 Frequency bands and channel arrangement

4.1 General

The information presented in this clause is based on a chip rate of 3,84 Mcps.

NOTE: Other chip rates may be considered in future releases.

4.2 Frequency bands

UTRA/FDD is designed to operate in either of the following paired bands;

- (a) 1920 – 1980MHz: Up-link (Mobile transmit, base receive)
2110 – 2170MHz: Down-link (Base transmit, mobile receive)
- (b)* 1850 – 1910MHz: Up-link (Mobile transmit, base receive)
1930 – 1990MHz: Down-link (Base transmit, mobile receive)

* Used in Region 2.

Additional allocations in ITU region 2 are FFS.

Deployment in other frequency bands is not precluded.

4.3 TX–RX frequency separation

- (a) The minimum transmit to receive frequency separation is 134,8 MHz and the maximum value is 245,2 MHz and all UE(s) shall support a TX–RX frequency separation of 190 MHz when operating in the paired band defined in subclause 4.2(a).
- (b) When operating in the paired band defined in subclause 4.2(b), all UE(s) shall support a TX-RX frequency separation of 80 MHz.
- (c) UTRA/FDD can support both fixed and variable transmit to receive frequency separation.
- (d) The use of other transmit to receive frequency separations in existing or other frequency bands shall not be precluded.

4.4 Channel arrangement

4.4.1 Channel spacing

The nominal channel spacing is 5 MHz, but this can be adjusted to optimize performance in a particular deployment scenario.

4.4.2 Channel raster

The channel raster is 200 kHz, which means that the center frequency must be an integer multiple of 200 kHz.

4.4.3 Channel number

The carrier frequency is designated by the UTRA Absolute Radio Frequency Channel Number (UARFCN). The value of the UARFCN in the IMT2000 band is defined as follows:

Table 4.1: UTRA Absolute Radio Frequency Channel Number

Uplink	$N_u = 5 * (F_{\text{uplink}} \text{ MHz})$	$0,0 \text{ MHz} \leq F_{\text{uplink}} \leq 3276,6 \text{ MHz}$ where F_{uplink} is the uplink frequency in MHz
Downlink	$N_d = 5 * (F_{\text{downlink}} \text{ MHz})$	$0,0 \text{ MHz} \leq F_{\text{downlink}} \leq 3276,6 \text{ MHz}$ where F_{downlink} is the downlink frequency in MHz

5 Transmitter Characteristics

5.1 General

Transmitting performance test of the UE is implemented during communicating with the SS via air interface. The procedure is used normal call protocol until the UE is communicating on traffic channel basically. On the traffic channel, the UE provides special function for testing that is called Logical Test Interface and the UE is tested using this function. (Refer to TS 34.109 Logical Test Interface (FDD) Special conformance testing functions).

Transmitting or receiving bit/symbol rate for test channel is shown in Table 5.1.

Table 5.1: Bit / Symbol rate for Test Channel

Type of User Information	User bit rate	DL DPCH symbol rate	UL DPCH bit rate	Remarks
12,2 kbps reference measurement channel	12,2 kbps	30 ksps	60 kbps	Standard Test

Unless detailed the transmitter characteristic are specified at the antenna connector of the UE. For UE with integral antenna only, a reference antenna with a gain of 0 dBi is assumed. Transmitter characteristics for UE(s) with multiple antennas/antenna connectors are FFS.

The UE antenna performance has a significant impact on system performance, and minimum requirements on the antenna efficiency are therefore intended to be included in future versions of this specification. It is recognized that different requirements and test methods are likely to be required for the different types of UE.

All the parameters in clause 5 are defined using the UL reference measurement channel (12,2 kbps) specified in subclause C.2.1.

The common RF test conditions are defined in Annex E, and each test conditions in this subclause should refer Annex E. An individual test conditions are defined in the paragraph of each test.

5.2 Maximum Output Power

5.2.1 Definition and applicability

The maximum output power and its tolerance are defined according to the Power Class of the UE.

The maximum output power refers to the measure power when averaged over the transmit slot at the maximum power control setting.

For UE using directive antennas for transmission, a class dependent limit will be placed on the maximum Effective Isotropic Radiated Power (EIRP).

The requirements and this test apply to all types of UTRA for the FDD UE.

5.2.2 Conformance requirements

The UE maximum output power shall be within the shown value in Table 5.2.1 even for the multi-code transmission mode.

Table 5.2.1: Maximum Output Power

Power Class	Maximum output power	Tolerance
1	+33 dBm	+1/-3 dB
2	+27 dBm	+1/-3 dB
3	+24 dBm	+1/-3 dB
4	+21 dBm	± 2 dB

The reference for this requirement is [1] TS 25.101 subclause 6.2.1.

5.2.3 Test purpose

To verify that the error of the UE maximum output power does not exceed the prescribed tolerance in Table 5.2.1.

An excess maximum output power has the possibility to interfere to other channels or other systems. A small maximum output power decreases the coverage area.

5.2.4 Method of test

5.2.4.1 Initial conditions

- (1) Connect the SS to the UE antenna connector as shown in Figure A.1.
- (2) A call is set up according to the Generic call setup procedure, and RF parameters are set up according to Table 5.2.2.
- (3) Enter the UE into loopback test mode and start the loopback test.

See [3] TS 34.108 and [4] TS 34.109 for details regarding generic call setup procedure and loopback test.

Table 5.2.2: Test parameters for Maximum Output Power

Parameter	Level / Status	Unit
Inner Loop Power Control	Enabled	

5.2.4.2 Procedure

- (1) Set and send continuously Up power control commands to the UE.
- (2) Measure the output power of the UE by Tester. The output power shall be averaged over the transmit one timeslot.

5.2.5 Test requirements

The error of measured output power, derived in step (2), shall not exceed the prescribed tolerance in Table 5.2.1.

5.3 Frequency Stability

5.3.1 Definition and applicability

The frequency stability is the difference between the RF modulated carrier frequency transmitted from the UE with AFC ON and assigned frequency. The UE transmitter tracks to the RF carrier frequency received from the BS. These signals will have an apparent error due to BS frequency.

The requirements and this test apply to all types of UTRA for the FDD UE.

5.3.2 Conformance requirements

The UE modulated carrier frequency shall be accurate to within $\pm 0,1$ ppm compared to carrier frequency received from the BS.

The reference for this requirement is [1] TS 25.101 subclause 6.3.

5.3.3 Test purpose

To verify that the UE carrier frequency error does not exceed $\pm 0,1$ ppm.

An excess error of the carrier frequency increases the transmission errors in the up link own channel.

This test verifies the ability of receiver to derive correct frequency information for transmitter.

5.3.4 Method of test

5.3.4.1 Initial conditions

- (1) Connect the SS to the UE antenna connector as shown in Figure A.1.
- (2) A call is set up according to the Generic call setup procedure, and RF parameters are set up according to Table 5.3.
- (3) Enter the UE into loopback test mode and start the loopback test.

See [3] TS 34.108 and [4] TS 34.109 for details regarding generic call setup procedure and loopback test.

Table 5.3: Test parameters for Frequency Stability

Parameter	Level / Status	Unit
DPCH_Ec	-117	dBm / 3,84 MHz
\hat{I}_{or}	-106,7	dBm / 3,84 MHz
Inner Loop Power Control	Enabled	
AFC	ON	
Modulation	ON	

5.3.4.2 Procedure

- (1) Set and send continuously Up power control commands to the UE until the UE output power shall be maximum level.
- (2) Measure the frequency error Δf , at the UE antenna connector by Tester using Global In-Channel-Tx-test (Annex B). Since counter method leads an incorrect result, EVM method shall be used.

5.3.5 Test requirements

For all measured bursts, the frequency error, derived in step (1), shall not exceed $\pm 0,1$ ppm.

5.4 Output Power Dynamics in the Uplink

Power control is used to limit the interference level.

5.4.1 Open Loop Power Control in the Uplink

5.4.1.1 Definition and applicability

Open loop power control in the uplink is the ability of the UE transmitter to set its output power to a specific value. This function is used for PRACH transmission and based on the information from BS using BCCH and the downlink received signal power level of the PCCPCH. The information from BS includes transmission power of PCCPCH and uplink interference power level.

The requirements and this test apply to all types of UTRA for the FDD UE.

5.4.1.2 Conformance requirements

The UE open loop power control tolerance is given in Table 5.4.1.1.

Table 5.4.1.1: Open loop power control tolerance

Normal conditions	± 9 dB
Extreme conditions	± 12 dB

The reference for this requirement is [1] TS 25.101 subclause 6.4.1.

5.4.1.3 Test purpose

The power of the received signal and the BCCH information control the power of the transmitted signal with the target to transmit at lowest power acceptable for proper communication.

The test stresses the ability of the receiver to measure the received power correctly over the receiver dynamic range.

The test purpose is to verify that the UE open loop power control tolerance does not exceed the described value shown in Table 5.4.1.1.

An excess error of the open loop power control decreases the system capacity.

5.4.1.4 Method of test

This test is also covered by subclause 5.5.2 Transmit ON/OFF Time mask.

5.4.1.4.1 Initial conditions

- (1) Connect the SS to the UE antenna connector as shown in Figure A.1.
- (2) A call is set up according to the Generic call setup procedure, and RF parameters are set up according to Table 5.4.1.2.
The RACH procedure within the call setup is used for the test.

See [3] TS 34.108 for details regarding generic call setup procedure.

Table 5.4.1.2: Test parameters for Open Loop Power Control (UE)

Parameter	Level / Status	Unit
\hat{I}_{or}	See Table 5.4.1.3	dBm / 3,84 MHz
Inner Loop Power Control	Disabled	

Table 5.4.1.3: Test parameters for Open Loop Power Control (SS)

Parameter	Upper dynamic range	middle	Sensitivity level
\hat{I}_{or} ³⁾	[-25,0 dBm / 3,84 MHz]	[-65,7 dBm / 3,84 MHz]	[-106,7 dBm / 3,84 MHz]
CPICH_RSCP ^{3),4)}	[-28,3 dBm]	[-69 dBm]	[-110 dBm]
Primary CPICH DL TX power	[+25 dBm]	[+31 dBm]	[+19 dBm]
Simulated path loss = Primary CPICH DL TX power – CPICH_RSCP	[+53,3 dB]	[+100 dB]	[+129 dB]
UL interference	[-75 dB]	[-101 dB]	[-110 dB]
Constant Value	[-10 dB]	[-10 dB]	[-10 dB]
Expected nominal UE TX power	[-31,7 dBm]	[-11 dBm]	[+9 dBm] ²⁾

NOTE 1: While the SS transmit power shall cover the receiver input dynamic range, the logical parameters: broadcasted transmit power, I_{BTS} , constant factor are chosen to achieve a UE TX power, located within the TX output power dynamic range of a class 4 UE.

NOTE 2: Nominal TX output power 9 dBm allows to check the open loop power algorithm within the entire tolerance range (9 dBm \pm 12 dB; 9 dBm + 12 dB = 21 dBm = max power class 4).

NOTE 3: The power level of SCCPCH should be defined because SCCPCH is transmitted instead of DPCH during Preamble RACH transmission period. Currently, it is assumed that Table E.3.1 is utilised for DL physical channel condition. The power level of SCCPCH is temporarily set to the same as DL DPCH. However, it is necessary to check whether the above SCCPCH level is enough to establish a connection with the reference measurement channels.

NOTE 4: The purpose of this parameter is to calculate the Expected nominal UE TX power.

5.4.1.4.2 Procedure

- (1) Set the TX output level of the SS to obtain \hat{I}_{or} at the UE antenna connector. \hat{I}_{or} shall be according to Table 5.4.1.3 ([-25 dBm / 3,84 MHz]).
- (2) Measure the RACH output power of the UE according to Annex B.
- (3) Repeat the above measurement for all SS levels in Table 5.4.1.3.

5.4.1.5 Test requirements

The deviation with respect to the Expected nominal UE TX power (Table 5.4.1.3), derived in step (2), shall not exceed the prescribed tolerance in Table 5.4.1.1.

5.4.2 Inner Loop Power Control in the Uplink

5.4.2.1 Definition and applicability

Inner loop power control in the uplink is the ability of the UE transmitter to adjust its output power in accordance with one or more TPC commands received in the downlink.

The power control step is the change in the UE transmitter output power in response to a single TPC command, TPC_cmd, derived at the UE.

This clause does not cover all the requirements of compressed mode or soft handover.

The requirements and this test apply to all types of UTRA for the FDD UE.

5.4.2.2 Conformance requirements

The UE transmitter shall have the capability of changing the output power with a step size of 1, 2 and 3 dB according to the value of Δ_{TPC} or Δ_{RP-TPC} , in the slot immediately after the TPC_cmd can be derived.

- (a) The transmitter output power step due to inner loop power control shall be within the range shown in Table 5.4.2.1. The Maximum power threshold is defined as the lowest permissible maximum output power for the UE power class, as defined in Table 5.2.1. The Minimum power threshold is defined as -44 dBm.
- (b) When the transmitter output power is between the Minimum and Maximum power thresholds, the transmitter average output power step due to inner loop power control shall be within the range shown in Table 5.4.2.2.

NOTE: 3dB inner loop power control steps are only used in compressed mode.

Table 5.4.2.1: Transmitter power control tolerance

TPC_cmd	Transmitter power control range (all units are in dB)					
	1 dB step size		2 dB step size		3 dB step size	
	Lower	Upper	Lower	Upper	Lower	Upper
+ 1	+0,5	+1,5	+1	+3	+1,5	+4,5
0	-0,5	+0,5	-0,5	+0,5	-0,5	+0,5
- 1	-0,5	-1,5	-1	-3	-1,5	-4,5
+ 1 at or above max power threshold	-0,5	+1,5	-0,5	+3	-0,5	+4,5
- 1 at or below min power threshold	+0,5	-1,5	+0,5	-3	+0,5	-4,5

Table 5.4.2.2: Transmitter average power control tolerance

TPC_cmd	Transmitter power control range after 10 equal TPC_cmd (all units are in dB)					
	1 dB step size		2 dB step size		3 dB step size	
	Lower	Upper	Lower	Upper	Lower	Upper
+ 1	+8	+12	+16	+24	+24	+36
0	-2	+2	-2	+2	-2	+2
- 1	-8	-12	-16	-24	-24	-36

The reference for this requirement is [1] TS 25.101 subclause 6.4.2.1.1.

The requirements for the derivation of TPC_cmd are detailed in TS 25.214 subclauses 5.1.2.2.2 and 5.1.2.2.3.

5.4.2.3 Test purpose

- To verify that the UE inner loop power control size and response is meet to the described value shown in subclause 5.4.2.2.
- To verify that TPC_cmd is correctly derived from received TPC commands.

An excess error of the inner loop power control decreases the system capacity.

5.4.2.4 Method of test

5.4.2.4.1 Initial conditions

- (1) Connect the SS to the UE antenna connector as shown in Figure A.1.
- (2) A call is set up according to the Generic call setup procedure, and RF parameters are set up according to Table 5.4.2.3. The Uplink DPCH Power Control Info shall specify the Power Control Algorithm as algorithm 2 for interpreting TPC commands.
- (3) Enter the UE into loopback test mode and start the loopback test.

See [3] TS 34.108 and [4] TS 34.109 for details regarding generic call setup procedure and loopback test.

Table 5.4.2.3: Test parameters for Inner Loop Power Control

Parameter	Level / Status	Unit
Inner Loop Power Control	Enabled	

5.4.2.4.2 Procedure

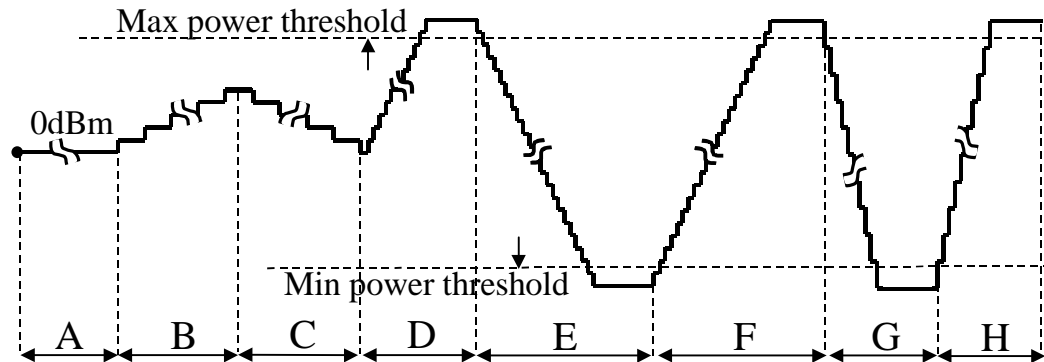

Figure 5.4.2.4 Inner Loop Power Control Test Steps

- (1) Set the attenuation in the downlink signal (\hat{I}_{or}) to yield an open loop output power, measured at the UE antenna connector, of 0 dBm.
- (2) Step A: Transmit a sequence of at least 30 TPC commands, which shall commence at a frame boundary and last for a whole number of frames, and which shall contain:
 - no sets of 5 consecutive "0" or "1" commands which commence in the 1st, 6th or 11th slots of a frame;
 - at least one set of 5 consecutive "0" commands which does not commence in the 1st, 6th or 11th slots of a frame;
 - at least one set of 5 consecutive "1" commands which does not commence in the 1st, 6th or 11th slots of a frame.

The following is an example of a suitable sequence of TPC commands:

```
100000101010101111101000001010101011111010000010101010111110
```

- (3) Step B: Transmit a sequence of 50 TPC commands with the value 1.
- (4) Step C: Transmit a sequence of 50 TPC commands with the value 0.
- (5) Step D: Reconfigure the uplink channel to set the Power Control Algorithm to algorithm 1, and the TPC step size to 1 dB. Transmit a sequence of 60¹ TPC commands with the value 1.
- (6) Step E: Transmit a sequence of 100¹ TPC commands with the value 0.
- (7) Step F: Transmit a sequence of 100¹ TPC commands with the value 1.
- (8) Step G: Reconfigure the uplink channel to set the TPC step size to 2 dB (with the Power Control Algorithm remaining as algorithm 1). Transmit a sequence of 50¹ TPC commands with the value 0.
- (9) Step H: Transmit a sequence of 50¹ TPC commands with the value 1.
- (10) During steps A to H the mean output power of every slot shall be measured.

¹ NOTE: These numbers of TPC commands are given as examples. The actual number of TPC commands transmitted in these steps shall be large enough to ensure that the UE reaches the relevant maximum or minimum power threshold in each step, as shown in Figure 5.4.2.4.

5.4.2.5 Test requirements

- (a) During Step A, the difference in mean output power between adjacent slots shall be within the prescribed range for a TPC_cmd of 0, as given in Table 5.4.2.1.
- (b) During Step A, the change in mean output power over 10 consecutive slots shall be within the prescribed range for a TPC_cmd of 0, as given in Table 5.4.2.2.
- (c) During Step B, the difference in mean output power between adjacent slots shall be within the prescribed range given in Table 5.4.2.1, given that every 5th TPC_cmd should have the value + 1, with a step size of 1 dB, and all other TPC_cmd should have the value 0.
- (d) During Step C, the difference in mean output power between adjacent slots shall be within the prescribed range given in Table 5.4.2.1, given that every 5th TPC_cmd should have the value – 1, with a step size of 1 dB, and all other TPC_cmd should have the value 0.
- (e) During Step D, the difference in mean output power between adjacent slots shall be within the prescribed range given in Table 5.4.2.1 for a TPC_cmd of + 1 and step size of 1 dB, until the output power reaches (Maximum power threshold – 0.5 dB). When the output power is between the values of (Maximum power threshold – 0.5 dB) and (Maximum power threshold), the difference in mean output power between adjacent slots shall be at least sufficient to increase the output power to the Maximum power threshold, but shall not exceed + 1.5 dB. Once the output power is at or above the Maximum power threshold, the relevant condition in Table 5.4.2.1 shall be met.
- (f) During Step D, the change in mean output power over 10 consecutive slots shall be within the prescribed range for a TPC_cmd of + 1 and step size of 1 dB as given in Table 5.4.2.2, until the output power reaches (Maximum power threshold – 0.5 dB).
- (g) During Step E, the difference in mean output power between adjacent slots shall be within the prescribed range given in Table 5.4.2.1 for a TPC_cmd of – 1 and step size of 1 dB, until the output power reaches (Minimum power threshold + 0.5 dB). When the output power is between the values of (Minimum power threshold + 0.5 dB) and (Minimum power threshold), the difference in mean output power between adjacent slots shall be at least sufficient to decrease the output power to the Minimum power threshold, but shall not exceed – 1.5 dB. Once the output power is at or below the Minimum power threshold, the relevant condition in Table 5.4.2.1 shall be met.
- (h) During Step E, the change in mean output power over 10 consecutive slots shall be within the prescribed range for a TPC_cmd of – 1, and step size of 1 dB as given in Table 5.4.2.2, until the output power reaches (Minimum power threshold + 0,5 dB).
- (i) During Step F, the difference in mean output power between adjacent slots shall be within the prescribed range given in Table 5.4.2.1 for a TPC_cmd of + 1 and step size of 1 dB, until the output power reaches (Maximum power threshold – 0,5 dB). When the output power is between the values of (Maximum power threshold – 0,5 dB) and (Maximum power threshold), the difference in mean output power between adjacent slots shall be at least sufficient to increase the output power to the Maximum power threshold, but shall not exceed + 1,5 dB. Once the output power is at or above the Maximum power threshold, the relevant condition in Table 5.4.2.1 shall be met.
- (j) During Step F, the change in mean output power over 10 consecutive slots shall be within the prescribed range for a TPC_cmd of + 1, and step size of 1 dB as given in Table 5.4.2.2, until the output power reaches (Maximum power threshold – 0,5 dB).
- (k) During Step G, the difference in mean output power between adjacent slots shall be within the prescribed range given in Table 5.4.2.1 for a TPC_cmd of – 1 and step size of 2 dB, until the output power reaches (Minimum power threshold + 1 dB). When the output power is between the values of (Minimum power threshold + 1 dB) and (Minimum power threshold), the difference in mean output power between adjacent slots shall be at least sufficient to decrease the output power to the Minimum power threshold, but shall not exceed – 3 dB. Once the output power is at or below the Minimum power threshold, the relevant condition in Table 5.4.2.1 shall be met.
- (l) During Step G, the change in mean output power over 10 consecutive slots shall be within the prescribed range for a TPC_cmd of – 1, and step size of 2 dB as given in Table 5.4.2.2, until the output power reaches (Minimum power threshold +1 dB).

- (m) During Step H, the difference in mean output power between adjacent slots shall be within the prescribed range given in Table 5.4.2.1 for a TPC_cmd of + 1 and step size of 2 dB, until the output power reaches (Maximum power threshold – 1 dB). When the output power is between the values of (Maximum power threshold – 1 dB) and (Maximum power threshold), the difference in mean output power between adjacent slots shall be at least sufficient to increase the output power to the Maximum power threshold, but shall not exceed + 3 dB. Once the output power is at or above the Maximum power threshold, the relevant condition in Table 5.4.2.1 shall be met.
- (n) During Step H, the change in mean output power over 10 consecutive slots shall be within the prescribed range for a TPC_cmd of + 1, and step size of 2 dB as given in Table 5.4.2.2, until the output power reaches (Maximum power threshold – 1 dB).

5.4.3 Minimum Output Power

5.4.3.1 Definition and applicability

The minimum controlled output power of the UE is when the power control setting is set to a minimum value. This is when both the inner loop and open loop power control indicate a minimum transmit output power is required.

The requirements and this test apply to all types of UTRA for the FDD UE.

5.4.3.2 Conformance requirements

The minimum transmit power shall be better than –44 dBm measured with a filter that has a Root-Raised Cosine (RRC) filter response with a roll off $\alpha = 0,22$ and a bandwidth equal to the chip rate.

The reference for this requirement is [1] TS 25.101 subclause 6.4.3.1.

5.4.3.3 Test purpose

To verify that the UE minimum transmit power is below –44 dBm.

An excess minimum output power increases the interference to other channels, and decreases the system capacity.

5.4.3.4 Method of test

5.4.3.4.1 Initial conditions

- (1) Connect the SS to the UE antenna connector as shown in Figure A.1.
- (2) A call is set up according to the Generic call setup procedure, and RF parameters are set up according to Table 5.4.3.
- (3) Enter the UE into loopback test mode and start the loopback test.

See [3] TS 34.108 and [4] TS 34.109 for details regarding generic call setup procedure and loopback test.

Table 5.4.3: Test parameters for Minimum Output Power

Parameter	Level / Status	Unit
Inner Loop Power Control	Enabled	

5.4.3.4.2 Procedure

- (1) Set and send continuously Down power control commands to the UE.
- (2) Measure the output power of the UE by Tester.

5.4.3.5 Test requirements

The measured output power, derived in step (2), shall be below -44 dBm.

5.5 Transmit ON/OFF Power

5.5.1 Transmit OFF Power

5.5.1.1 Definition and applicability

The transmit OFF power state is when the UE does not transmit except during uplink DTX mode. This parameter is defined as the maximum output transmit power within the channel bandwidth when the transmitter is OFF.

The requirements and this test apply to all types of UTRA for the FDD UE.

5.5.1.2 Conformance requirements

The requirement for the transmit OFF power shall be better than -50 dBm measured with a filter that has a Root-Raised Cosine (RRC) filter response with a roll off $\alpha = 0,22$ and a bandwidth equal to the chip rate.

The reference for this requirement is [1] TS 25.101 subclause 6.5.1.1.

5.5.1.3 Test purpose

To verify that the UE transmit OFF power is below -50 dBm.

An excess transmit OFF power increases the interference to other channels, and decreases the system capacity.

5.5.1.4 Method of test

This test is also covered by subclause 5.5.2 Transmit ON/OFF Time mask.

5.5.1.4.1 Initial conditions

- (1) Connect the SS to the UE antenna connector as shown in Figure A.1.
- (2) A call is set up according to the Generic call setup procedure, and RF parameters are set up according to Annex E.
- (3) Enter the UE into loopback test mode and start the loopback test.

See [3] TS 34.108 and [4] TS 34.109 for details regarding generic call setup procedure and loopback test.

5.5.1.4.2 Procedure

- (1) Send release message to the UE to stop transmitting.
- (2) Measure the leakage power within the transmission band from the UE by the Tester.

5.5.1.5 Test requirements

The measured leakage power, derived in step (2), shall be below -50 dBm.

5.5.2 Transmit ON/OFF Time mask

5.5.2.1 Definition and applicability

The time mask for transmit ON/OFF defines the ramping time allowed for the UE between transmit OFF power and transmit ON power. Possible ON/OFF scenarios are PRACH or uplink slotted mode

The requirements and this test apply to all types of UTRA for the FDD UE.

5.5.2.2 Conformance requirements

The transmit power levels versus time should meet the mask specified in Figure 5.5.

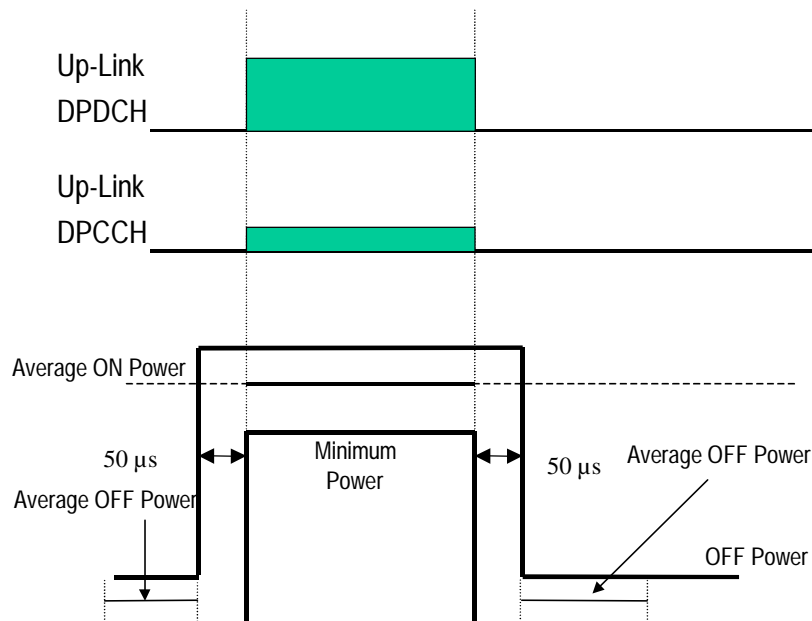

Figure 5.5: Transmit ON/OFF template

OFF Power is defined in 5.5.1.

ON power is defined as either case as follows. The specification depends on each possible case.

- First preamble of PRACH: Open loop accuracy (subclause 5.4.1).
- During preamble ramping of the RACH and compressed mode: Accuracy depending on size of the power step.
- Power step to Maximum Power: Maximum power accuracy.

The reference for this requirement is [1] TS 25.101 subclause 6.5.2.1.

This is tested using PRACH operation.

The minimum requirement for ON power is defined in subclause 5.4.1.2.

The minimum requirement for OFF power is defined in subclause 5.5.1.2.

5.5.2.3 Test purpose

To verify that the UE transmit ON/OFF power levels versus time meets the described mask shown in Figure 5.5.

An excess error of transmit ON/OFF response increases the interference to other channels, or increases transmission errors in the up link own channel.

5.5.2.4 Method of test

5.5.2.4.1 Initial conditions

- (1) Connect the SS to the UE antenna connector as shown in Figure A.1.
- (2) A call is set up according to the Generic call setup procedure, and RF parameters are set up according to Table 5.5.2.1.

The RACH procedure within the call setup is used for the test.

See [3] TS 34.108 for details regarding generic call setup procedure.

Table 5.5.2.1: Test parameters for Transmit ON/OFF Time mask (UE)

Parameter	Level / Status	Unit
\hat{I}_{or}	See Table 5.5.2.2	dBm / 3,84 MHz
Inner Loop Power Control	Disabled	

Table 5.5.2.2: Test parameters for Transmit ON/OFF Time mask (SS)

Parameter	Upper dynamic range	middle	Sensitivity level
\hat{I}_{or} ³⁾	[-25,0 dBm / 3,84 MHz]	[-65,7 dBm / 3,84 MHz]	[-106,7 dBm / 3,84 MHz]
CPICH_RSCP ^{3),4)}	[-28,3 dBm]	[-69 dBm]	[-110 dBm]
Primary CPICH DL TX power	[+25 dBm]	[+31 dBm]	[+19 dBm]
Simulated path loss = Primary CPICH DL TX power – CPICH_RSCP	[+53,3 dB]	[+100 dB]	[+129 dB]
UL interference	[-75 dB]	[-101 dB]	[-110 dB]
Constant Value	[-10 dB]	[-10 dB]	[-10 dB]
Expected nominal UE TX power	[-31,7 dBm]	[-11 dBm]	[+9 dBm] ²⁾

NOTE 1: While the SS transmit power shall cover the receiver input dynamic range, the logical parameters: broadcasted transmit power, I_{BTS} , constant factor are chosen to achieve a UE TX power, located within the TX output power dynamic range of a class 4 UE.

NOTE 2: Nominal TX output power 9 dBm allows to check the open loop power algorithm within the entire tolerance range (9 dBm \pm 12 dB; 9dBm + 12dB = 21dBm = max power class 4).

NOTE 3: The power level of SCCPCH should be defined because SCCPCH is transmitted instead of DPCH during Preamble RACH transmission period. Currently, it is assumed that Table E.3.1 is utilised for DL physical channel condition. The power level of SCCPCH is temporarily set to the same as DL DPCH. However, it is necessary to check whether the above SCCPCH level is enough to establish a connection with the reference measurement channels.

NOTE 4: The purpose of this parameter is to calculate the Expected nominal UE TX power.

5.5.2.4.2 Procedure

- (1) Set the TX output level of the SS to obtain \hat{I}_{or} at the UE antenna connector. \hat{I}_{or} shall be according to Table 5.5.2.2 ([-25 dBm / 3,84 MHz]).
- (2) Measure the RACH output power of the UE according to Annex B.
- (3) Measure OFF power immediate before and after RACH (ON power) except transient period.
- (4) Repeat the above measurement for all SS levels in Table 5.5.2.2.

5.5.2.5 Test requirements

The deviation with respect to the Expected nominal UE TX power (Table 5.5.2.2), derived in step (2), shall not exceed the prescribed tolerance in Table 5.4.1.1. (Subclause 5.4.1.2).

The measured leakage power, derived in step (3), shall below -50 dBm. (Subclause 5.5.1.2).

5.6 Change of TFC

5.6.1 Definition and applicability

A change of TFC (Transport Format Combination) in uplink means that the power in the uplink varies according to the change in data rate. DTX, where the DPCH is turned off, is a special case of variable data, which is used to minimise the interference between UE(s) by reducing the UE transmit power when voice, user or control information is not present.

The requirements and this test apply to all types of UTRA for the FDD UE.

5.6.2 Conformance requirements

A change of output power is required when the TFC, and thereby the data rate, is changed. The ratio of the amplitude between the DPDCH codes and the DPCCCH code will vary. The power step due to a change in TFC shall be calculated in the UE so that the power transmitted on the DPCCCH shall follow the inner loop power control. The power step shall then be rounded to the closest integer dB value. A power step size exactly half-way between two integer values shall be rounded to the closest integer of greatest magnitude. The accuracy of the power step, given the step size is specified in Table 5.6.1.

Table 5.6.1: Transmitter power step tolerance

Power control step size (Up or down) ΔP [dB]	Transmitter power step tolerance
0	+/- 0,5 dB
1	+/- 0,5 dB
2	+/- 1,0 dB
3	+/- 1,5 dB
$4 \leq \Delta P \leq 10$	+/- 2 dB
$11 \leq \Delta P \leq 15$	+/- 3 dB
$16 \leq \Delta P \leq 20$	+/- 4 dB
$21 \leq \Delta P$	+/- 6 dB

TS 25.101 Annex A defines the UL reference measurement channels (12,2 kbps) for TX test and the power ratio between DPCCCH and DPDCH as -6 dB. Therefore, only one power control step size is selected as minimum requirement from Table 5.6.1. The accuracy of the power step, given the step size is specified in Table 5.6.2.

Table 5.6.2: Transmitter power step tolerance for test

Quantized amplitude ratios β_c and β_d	Power control step size (Up or down) ΔP [dB]	Transmitter power step tolerance
$\beta_c = 0,5333$, $\beta_d = 1,0$	[7 (6,54)]	+/- 2 dB

The transmit power levels versus time should meet the mask specified in Figure 5.6.1. When power increases the power step shall be performed before the frame boundary, when power decreases the power step shall be performed after the frame boundary.

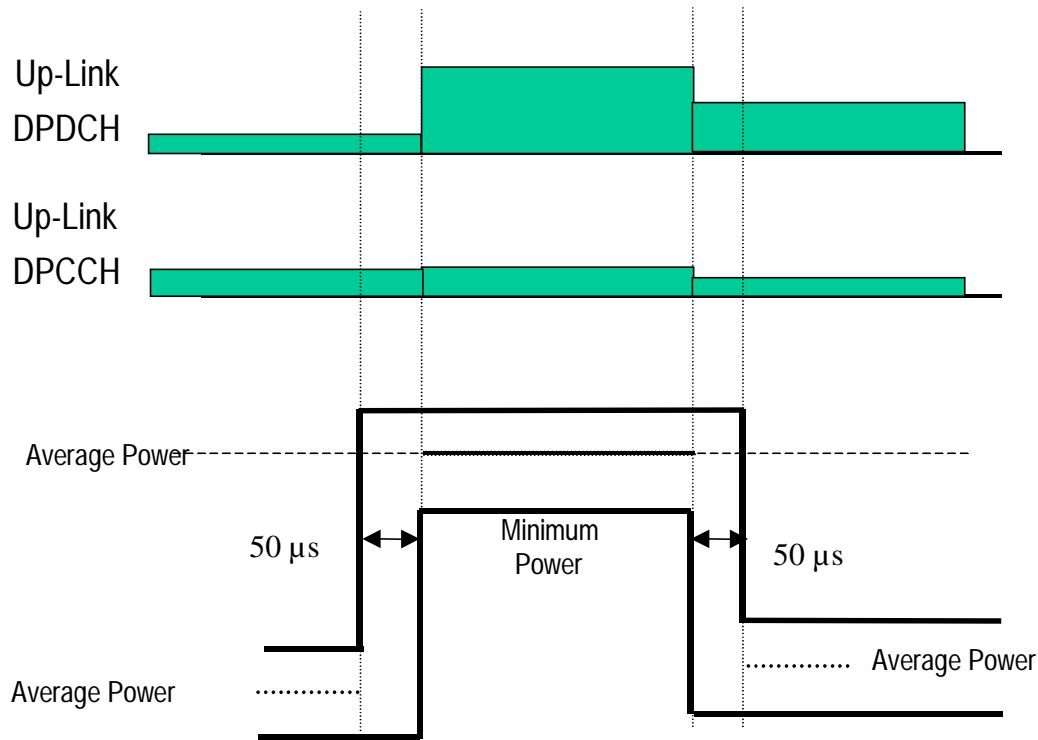

Figure 5.6.1: Transmit template during TFC change

The UL reference measurement channel (12,2 kbps) is fixed rate channel. Therefore, DTX, where the DPDCH is turned off, is tested, as shown in Figure 5.6.2.

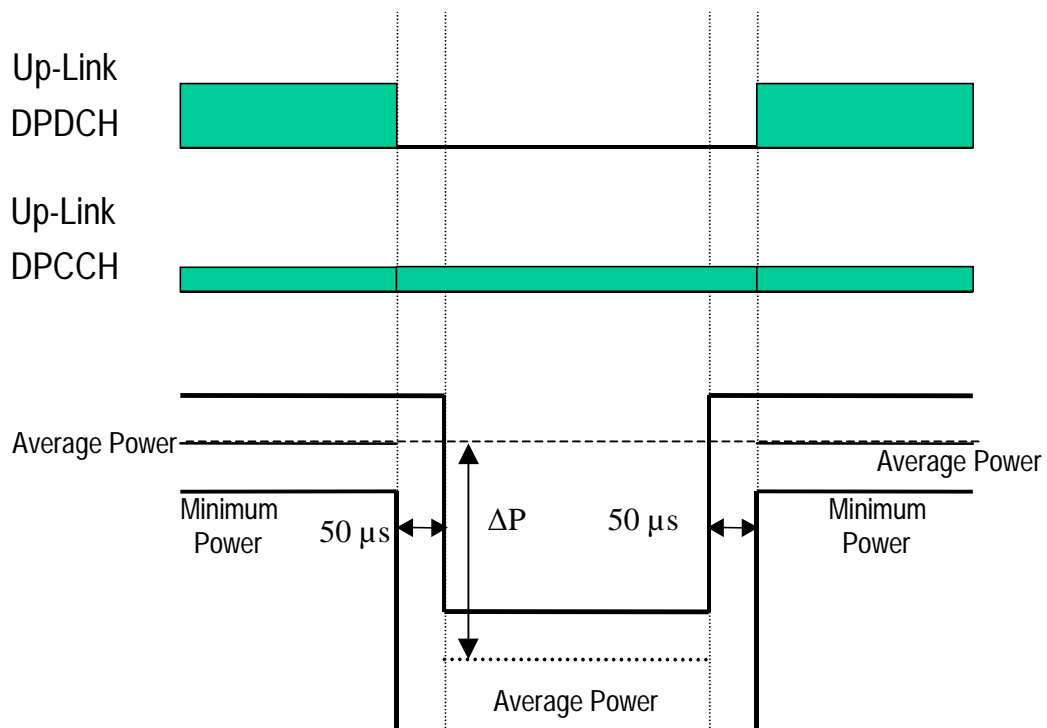

Figure 5.6.2: Transmit template during DTX

The reference for this requirement is [1] TS 25.101 subclause 6.5.3.1.

5.6.3 Test purpose

To verify that the tolerance of power control step size does not exceed the described value shown in Table 5.6.2.

To verify that the DTX ON/OFF power levels versus time meets the described mask shown in Figure 5.6.2.

5.6.4 Method of test

5.6.4.1 Initial conditions

- (1) Connect the SS to the UE antenna connector as shown in Figure A.1.
- (2) A call is set up according to the Generic call setup procedure, and RF parameters are set up according to Annex E. The Uplink DPCH Power Control Info shall specify the Power Control Algorithm as algorithm 2 for interpreting TPC commands.
- (3) Enter the UE into loopback test mode and start the loopback test.

See [3] TS 34.108 and [4] TS 34.109 for details regarding generic call setup procedure and loopback test.

5.6.4.2 Procedure

- (1) Set the attenuation in the downlink signal (\hat{I}_{or}) to yield an open loop output power, measured at the UE antenna connector, of 0 dBm.
- (2) Send alternating "0" and "1" TPC commands in the downlink so as to satisfy the condition of obtaining $TPC_cmd = 0$.
- (3) Measure the average output power at the antenna connector of the UE by Tester in two cases, both DPDCH and DPCCH are ON and only DPCCH is ON.

5.6.5 Test requirements

The difference in mean output power between DPDCH ON and OFF, derived in step (3), shall not exceed the prescribed range in Table 5.6.2.

5.7 Power setting in uplink compressed mode

5.7.1 Definition and applicability

Compressed mode in uplink means that the power in uplink is changed.

The requirements and this test apply to all types of UTRA for the FDD UE.

5.7.2 Conformance requirements

A change of output power is required during uplink compressed frames since the transmission of data is performed in a shorter interval. The ratio of the amplitude between the DPDCH codes and the DPCCH code will also vary. The power step due to compressed mode shall be calculated in the UE so that the energy transmitted on the pilot bits during each transmitted slot shall follow the inner loop power control. Thereby the power step during the transmitted part of a compressed frame shall be such that the power on the DPCCH follows the inner loop power control with an additional power offset during a compressed frame of $N_{pilot,N} / N_{pilot,C}$ where $N_{pilot,C}$ is the number of pilot bits per slot when in compressed mode, and $N_{pilot,N}$ is the number of pilot bits per slot in normal mode.

In addition to any power change due to the ratio $N_{pilot,N} / N_{pilot,C}$, the average power in the first slot after a compressed mode transmission gap shall differ from the average power in the last slot before the transmission gap by an amount Δ_{RESUME} , where Δ_{RESUME} is calculated as described in subclause 5.1.2.3 of TS 25.214.

The combined power step shall then be rounded to the closest integer dB value. A power step size exactly half-way between two integer values shall be rounded to the closest integer of greatest magnitude. The accuracy of the power step, given the step size is specified in Table 5.6.1 in paragraph 5.6.2.

The transmit power levels versus time shall meet the mask specified in Figure 5.7.1. When power increases the power step shall be performed before the actual slot boundary, when power decreases the power step shall be performed after the actual slot boundary.

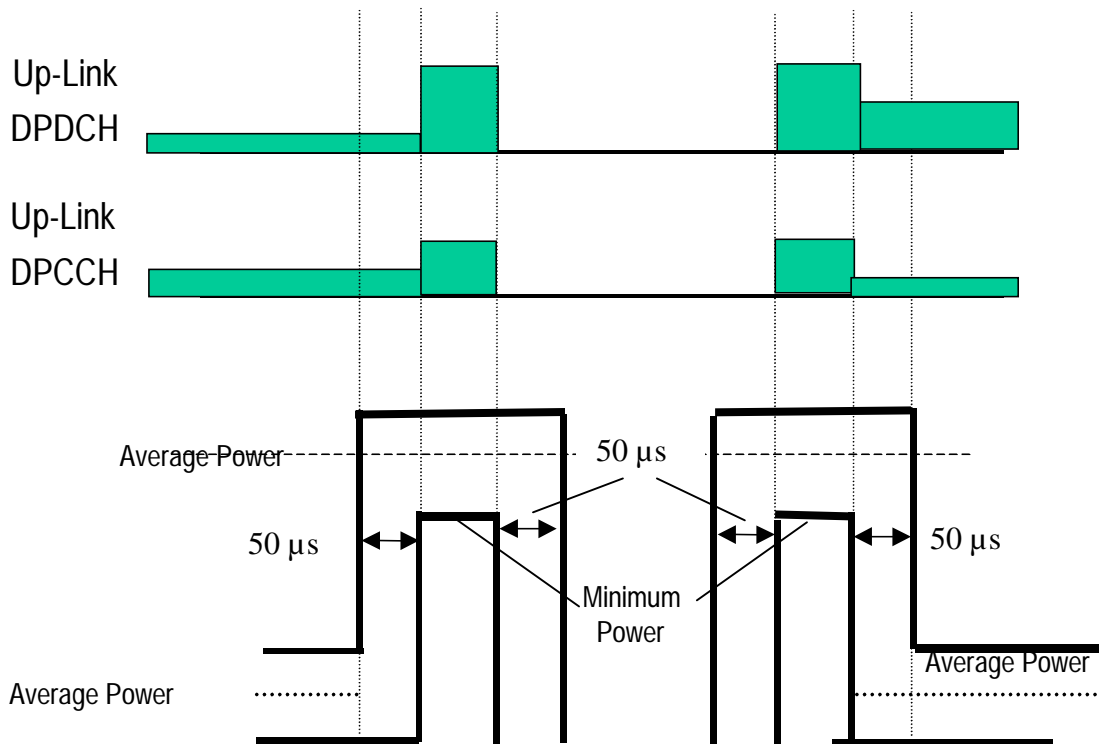

Figure 5.7.1: Transmit template during Compressed mode

The reference for this requirement is [1] TS 25.101 subclause 6.5.4.1.

The mean power in the transmission gaps, not including the 50 μs transition periods, shall be less than -50 dBm. The reference for this requirement is [1] TS 25.101 subclause 6.5.1.1.

For RPL (Recovery Period Length) slots after the transmission gap, where RPL is the minimum out of the transmission gap length and 7 slots, the UE shall use the power control algorithm and step size specified by the signalled Power Control Mode, as detailed in TS 25.214 subclause 5.1.2.3.

When nominal 3 dB power control steps are used in the recovery period, the transmitter output power steps due to inner loop power control shall be within the range shown in Table 5.7.2, and the transmitter average output power step due to inner loop power control shall be within the range shown in Table 5.7.3, excluding any other power changes due, for example, to changes in spreading factor or number of pilot bits.

Table 5.7.2: Transmitter power control range for 3dB step size

TPC_cmd	Transmitter power control range for 3dB step size	
	Lower	Upper
+ 1	+1,5 dB	+4,5 dB
0	-0,5 dB	+0,5 dB
- 1	-1,5 dB	-4,5 dB

Table 5.7.3: Transmitter average power control range for 3dB step size

TPC_cmd	Transmitter power control range after 7 equal TPC_cmd	
	Lower	Upper
+ 1	+16 dB	+26 dB
0	-2 dB	+2 dB
- 1	-16 dB	-26 dB

The reference for this requirement is TS 25.101 subclause 6.4.2.1.1.

5.7.3 Test purpose

To verify that the changes in uplink transmit power in compressed mode are within the prescribed tolerances.

Excess error in transmit power setting in compressed mode increases the interference to other channels, or increases transmission errors in the uplink.

5.7.4 Method of test

5.7.4.1 Initial conditions

- (1) Connect the SS to the UE antenna connector as shown in Figure A.1.
- (2) A call is set up according to the Generic call setup procedure, and RF parameters are set up according to Table 5.7.4. The 12,2 kbps UL reference measurement channel is used, with gain factors $\beta_c = 0,5333$ and $\beta_d = 1$.
- (3) Enter the UE into loopback test mode and start the loopback test.

See [3] TS 34.108 and [4] TS 34.109 for details regarding generic call setup procedure and loopback test.

Table 5.7.4: Test parameters for Power Setting in Uplink Compressed Mode

Parameter	Level / Status	Unit
Inner Loop Power Control	Enabled	

5.7.4.2 Procedure

<Editor's Note: The following procedure and test requirements are still under discussion. This might not be consistent with the core specification TS25.101 until the next revision.>

- (1) Set the attenuation in the downlink signal (\hat{I}_{or}) to yield an open loop output power, measured at the UE antenna connector, of -10 dBm.
- (2) Signal the uplink power control parameters to use Algorithm 1 and a step size of 2 dB.
- (3) Use Slot Format #0 on the uplink DPCCH.
- (4) During the time period between CFN #57 and CFN #253, signal the following sets of compressed mode parameters. These sets of compressed mode parameters define 5 compressed mode patterns which are used for the test between CFN #254 and CFN #56.

Pattern A

This set of compressed mode parameters results in a set of 5 uplink frames in which the first 2 frames are compressed, with a 10-slot transmission gap beginning at the 11th slot of the first compressed frame, as shown in Figure 5.7.2.

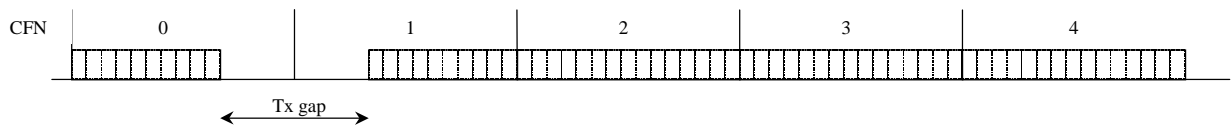

Figure 5.7.2: Pattern A for compressed mode test

This is used to test the implementation of PRM = 0 and PCM = 0.

Parameter	Value
TGL	10 slots
CFN	0
SN	10
TGP1	5 frames
TGD	0
PD	5 frames
PCM	0
PRM	0
UL/DL Mode	UL/DL
Compressed Mode Method	SF/2
Scrambling code change	No code change
Downlink frame type	A
DeltaSIR	0
DeltaSIRafter	0

Pattern B

This set of compressed mode parameters results in a series of 10 sets of 3 frames in which the first 2 frames in each set are compressed, with a 10-slot transmission gap beginning at the 11th slot of the first compressed frame.

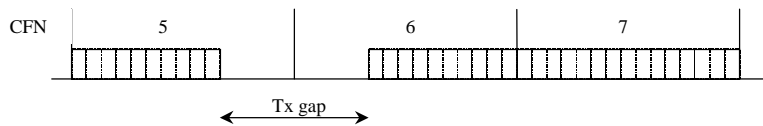

Figure 5.7.3: Pattern B for compressed mode test

This is used to test the implementation of 3dB output power steps and PCM = 1.

Parameter	Value
TGL	10 slots
CFN	5
SN	10
TGP1	3
TGD	0
PD	30
PCM	1
PRM	0
UL/DL Mode	UL/DL
Compressed Mode Method	SF/2
Scrambling code change	No code change
Downlink frame type	A
DeltaSIR	0
DeltaSIRafter	0

Pattern C

This set of compressed mode parameters results in 4 sets of 4 frames in which the first 2 frames in each set are compressed, with a 10-slot transmission gap beginning at the 11th slot of the first compressed frame.

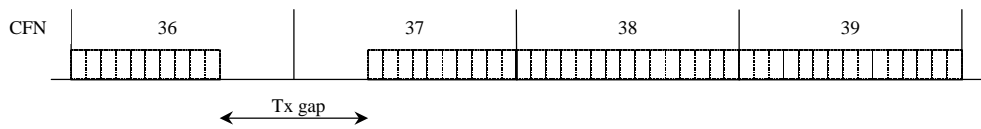

Figure 5.7.4: Pattern C for compressed mode test

This is used to test the implementation of PRM = 1.

Parameter	Value
TGL	10 slots
CFN	36
SN	10
TGP1	4
TGD	0
PD	16
PCM	0
PRM	1
UL/DL Mode	UL/DL
Compressed Mode Method	SF/2
Scrambling code change	No code change
Downlink frame type	A
DeltaSIR	0
DeltaSIRafter	0

Pattern D

This set of compressed mode parameters results in a set of 2 frames in which the first frame is compressed, with a 4-slot transmission gap beginning in the 1st slot of the compressed frame.

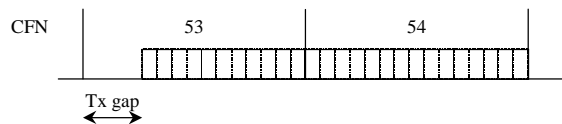

Figure 5.7.5: Pattern D for compressed mode test

This is used to test the implementation of a transmission gap at the start of a frame.

Parameter	Value
TGL	4 slots
CFN	53
SN	0
TGP1	2
TGD	0
PD	2
PCM	0
PRM	1
UL/DL Mode	UL/DL
Compressed Mode Method	SF/2
Scrambling code change	No code change
Downlink frame type	A
DeltaSIR	0
DeltaSIRafter	0

Pattern E

This set of compressed mode parameters results in a set of 2 frames in which the first frame is compressed, with a 4-slot transmission gap beginning at the 12th slot of the compressed frame.

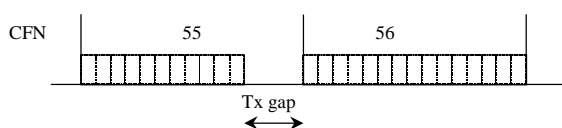

Figure 5.7.6: Pattern E for compressed mode test

This is used to test the implementation of a transmission gap at the end of a frame.

Parameter	Value
TGL	4 slots
CFN	55
SN	11
TGP1	2
TGD	0
PD	2
PCM	0
PRM	1
UL/DL Mode	UL/DL
Compressed Mode Method	SF/2
Scrambling code change	No code change
Downlink frame type	A
DeltaSIR	0
DeltaSIRafter	0

(5) Transmit TPC commands on the downlink as follows:

CFN	TPC commands in downlink	Compressed Mode Pattern
254 (and all previous even-numbered CFNs)	0 1 0 1 0 1 0 1 0 1 0 1 0 1 0	
255 (and all previous odd-numbered CFNs)	1 0 1 0 1 0 1 0 1 0 1 0 1 0 1	
0	0 1 1 1 1 1 1 1 1 1 1 1 1 1 1	A
1	1 1 1 1 1 1 1 1 1 1 1 1 1 1 1	
2	0 1 0 1 0 1 0 1 0 1 0 1 0 1 0	
3	1 0 1 0 1 0 1 0 1 0 1 0 1 0 1	
4	0 1 0 1 0 1 0 1 0 1 0 1 0 1 0	
5, 8, 11, 14, 17	1 1 1 1 1 1 1 1 1 1 1 1 1 1 1	B
6, 9, 12, 15, 18	1 1 1 1 1 1 1 1 1 1 1 1 1 1 1	
7, 10, 13, 16, 19	0 1 0 1 0 1 0 1 0 1 0 1 0 1 0	
20	1 0 1 0 1 0 1 0 1 0 1 0 1 0 1	
23, 26, 29, 32	0 0 0 0 0 0 0 0 0 0 0 0 0 0 0	
21, 24, 27, 30, 33	1 1 1 1 1 1 1 1 1 1 1 1 1 1 1	
22, 25, 28, 31, 34	0 1 0 1 0 1 0 1 0 1 0 1 0 1 0	
35	0 1 0 1 0 1 0 1 0 1 0 1 0 1 0	C
36	1 0 0 0 0 0 0 0 0 0 0 0 0 0 0	
37	1 1 1 1 1 1 1 1 1 1 1 1 1 1 1	
38	0 1 0 1 0 1 0 1 0 1 0 1 0 1 0	
39	1 0 1 0 1 0 1 0 1 0 1 0 1 0 1	
40	0 1 0 1 0 1 0 1 0 1 0 1 0 1 0	
41	1 0 0 0 0 0 0 0 0 0 0 0 0 0 0	
42	1 1 1 1 1 1 1 1 1 1 1 1 1 1 1	
43	0 1 0 1 0 1 0 1 0 1 0 1 0 1 0	
44, 48	1 0 1 0 1 0 1 0 1 0 1 0 1 0 1	
45, 49	0 1 1 1 1 1 1 1 1 1 1 1 1 1 1	
46, 50	1 0 0 0 0 0 0 0 0 0 0 0 0 0 0	
47, 51	1 1 1 1 1 1 1 1 1 1 1 1 1 1 1	
52	0 1 0 1 0 1 0 1 0 1 0 1 0 1 0	
53	1 1 1 1 1 1 1 1 1 1 1 1 1 1 1	
54	0 1 0 1 0 1 0 1 0 1 0 1 0 1 0	
55	1 0 1 0 1 0 1 0 1 0 1 1 1 1 1	
56	1 1 0 1 0 1 0 1 0 1 0 1 0 1 0	E

(6) Measure the mean output power in every slot (not including 50 μ s transition periods) which is:

- the last slot before a compressed frame; *or*
- the first slot in a compressed frame; *or*
- the last slot before a transmission gap; *or*
- the first slot after a transmission gap; *or*
- the last slot of a compressed frame; *or*
- the first slot after a compressed frame.

Measure the mean output power in every uplink transmission gap (not including 50 μ s transition periods).

5.7.5 Test requirements

For ease of reference, the following uplink output power measurements are defined in Figure 5.7.7. In this figure:

- P_i is the mean power in the uplink transmission gap, excluding the 50 μ s transient periods.

When the transmission gap is not at the beginning of a compressed frame:

- P_a is the mean power in the last slot before the compressed frame (or pair of compressed frames), excluding the 50 μ s transient period.
- P_b is the mean power in the first slot of the compressed frame.
- P_c is the mean power in the last slot before the transmission gap.

When the transmission gap is not at the end of a compressed frame:

- P_d is the mean power in the first slot after the transmission gap.
- P_e is the mean power in the last slot of the compressed frame.
- P_f is the mean power in the first slot after the compressed frame (or pair of compressed frames), excluding the 50 μ s transient period.

When the transmission gap is at the beginning of the compressed frame:

- P_g is the mean power in the last slot before the compressed frame.

When the transmission gap is at the end of the compressed frame:

- P_h is the mean power in the first slot after the compressed frame.

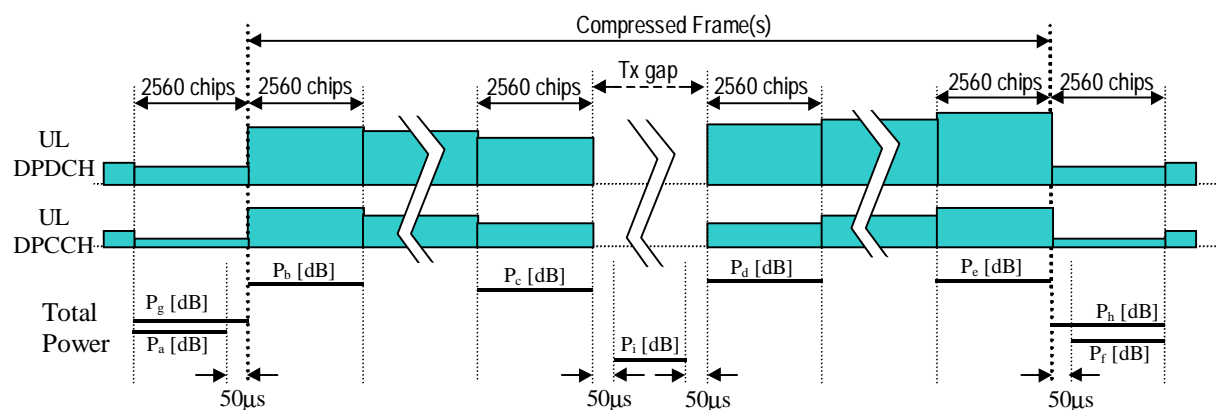

Figure 5.7.7: Uplink transmit power in uplink compressed mode

1. In CFNs 0, 23, 26, 29, 32, 44 and 48, $P_b - P_a$ should be within the range 4 ± 2 dB.
2. In CFNs 5, 8, 11, 14, 17, 20, 36 and 40 $P_b - P_a$ should be within the range $0 \pm 0,5$ dB.
3. In CFNs 1, 6, 9, 12, 15, 18, 21, 24, 27, 30 and 33, $P_d - P_c$ should be within the range $0 \pm 0,5$ dB.
4. In CFNs 0, 1, 5, 6, 8, 9, 11, 12, 14, 15, 17, 18, 20, 21, 23, 24, 26, 27, 29, 30, 32, 33, 36, 37, 40, 41, 44, 45, 48, 49, 53 and 55, P_i should be less than -50 dBm.
5. In CFNs 2, 7, 10, 13, 16, 19, 42, 46 and 50, $P_f - P_e$ should be within the range $0 \pm 0,5$ dB.
6. In CFNs 22, 25, 28, 31, 34, 38 and 54, $P_f - P_e$ should be within the range -4 ± 2 dB.
7. In slots 5-12 of CFN 1, the difference in mean output power between adjacent slots should be within the range given in Table 5.4.2.1 for $TPC_cmd = -1$ with a 2 dB step size.
8. In slots 5-12 of CFNs 6, 9, 12, 15 and 18, the difference in mean output power between adjacent slots should be within the range given in Table 5.7.2 for $TPC_cmd = -1$.
9. In slots 5-12 of CFNs 6, 9, 12, 15 and 18, the change in mean output power over the 7 slots should be within the range given in Table 5.7.3 for $TPC_cmd = -1$.

10. In slots 5-12 of CFNs 21, 24, 27, 30 and 33, the difference in mean output power between adjacent slots should be within the range given in Table 5.7.2 for $TPC_cmd = 1$.
11. In slots 5-12 of CFNs 21, 24, 27, 30 and 33, the change in mean output power over the 7 slots should be within the range given in Table 5.7.3 for $TPC_cmd = -1$.
12. In CFN 37, $P_d - P_c$ should be within the range $+12 \pm 3$ dB.
13. In CFN 41, $P_d - P_c$ should be within the range $+13 \pm 3$ dB.
14. In CFN 45, $P_d - P_c$ should be within the range -12 ± 3 dB.
15. In CFN 49, $P_d - P_c$ should be within the range -13 ± 3 dB.
16. In CFN 53, $P_d - P_g$ should be within the range -3 ± 1.5 dB.
17. In CFN 55, $P_b - P_a$ should be within the range $+4 \pm 2$ dB.
18. In CFN 56, $P_h - P_c$ should be within the range -6 ± 2 dB.

5.8 Occupied Bandwidth (OBW)

5.8.1 Definition and applicability

Occupied bandwidth is a measure of the bandwidth containing 99 % of the total integrated power of the transmitted spectrum, centered on the assigned channel frequency.

The requirements and this test apply to all types of UTRA for the FDD UE.

5.8.2 Conformance requirements

The occupied channel bandwidth shall be less than 5 MHz based on a chip rate of 3,84 Mcps.

The reference for this requirement is [1] TS 25.101 subclause 6.6.1.

5.8.3 Test purpose

To verify that the UE occupied channel bandwidth is less than 5 MHz based on a chip rate of 3,84 Mcps.

Excess occupied channel bandwidth increases the interference to other channels or to other systems.

5.8.4 Method of test

5.8.4.1 Initial conditions

- (1) Connect the SS to the UE antenna connector as shown in Figure A.1.
- (2) A call is set up according to the Generic call setup procedure, and RF parameters are set up according to Table 5.8.1.
- (3) Enter the UE into loopback test mode and start the loopback test.

See [3] TS 34.108 and [4] TS 34.109 for details regarding generic call setup procedure and loopback test.

Table 5.8.1: Test parameters for Occupied Bandwidth

Parameter	Level / Status	Unit
Inner Loop Power Control	Enabled	
DTX mode	Off	

5.8.4.2 Procedure

- (1) Set and send continuously Up power control commands to the UE until the UE output power shall be maximum level.
- (2) Measure the power spectrum distribution within two times or more range over the requirement for Occupied Bandwidth specification centering on the current carrier frequency with 30 kHz or less RBW. The characteristic of the filter shall be approximately Gaussian (typical spectrum analyzer filter).
- (3) Calculate the total power within the range of all frequencies measured in '(2)' and save this value as "Total Power".
- (4) Sum up the power upward from the lower boundary of the measured frequency range in '(2)' and seek the limit frequency point by which this sum becomes 0.5 % of "Total Power" and save this point as "Lower Frequency".
- (5) Sum up the power downward from the upper boundary of the measured frequency range in '(2)' and seek the limit frequency point by which this sum becomes 0.5 % of "Total Power" and save this point as "Upper Frequency".
- (6) Calculate the difference ("Upper Frequency" – "Lower Frequency" = "Occupied Bandwidth") between two limit frequencies obtained in '(4)' and '(5)'.

5.8.5 Test requirements

The measured Occupied Bandwidth, derived in step (6), shall not exceed 5 MHz.

5.9 Spectrum emission mask

5.9.1 Definition and applicability

The spectrum emission mask of the UE applies to frequencies, which are between 2,5 MHz and 12,5 MHz away from the UE center carrier frequency. The out of channel emission is specified relative to the UE output power measured in a 3,84 MHz bandwidth.

The requirements and this test apply to all types of UTRA for the FDD UE.

5.9.2 Conformance requirements

The power of any UE emission shall not exceed the levels specified in Table 5.9.1.

Table 5.9.1: Spectrum Emission Mask Requirement

Frequency offset from carrier Δf	Minimum requirement	Measurement bandwidth
2,5 - 3,5 MHz	$-35 - 15 \cdot (\Delta f - 2.5)$ dBc	30 kHz *
3,5 - 7,5 MHz	$-35 - 1 \cdot (\Delta f - 3.5)$ dBc	1 MHz *
7,5 - 8,5 MHz	$-39 - 10 \cdot (\Delta f - 7.5)$ dBc	1 MHz *
8,5 - 12,5 MHz	-49 dBc	1 MHz *

NOTE*:

1. The first and last measurement position with a 30 kHz filter is 2,515 MHz and 3,485 MHz.
2. The first and last measurement position with a 1 MHz filter is 4 MHz and 12 MHz.
3. The lower limit shall be -50 dBm / 3,84 MHz or which ever is higher.

The reference for this requirement is [1] TS 25.101 subclause 6.6.2.1.1.

5.9.3 Test purpose

To verify that the power of UE emission does not exceed the prescribed limits shown in Table 5.9.1.

Excess emission increases the interference to other channels or to other systems.

5.9.4 Method of test

5.9.4.1 Initial conditions

- (1) Connect the SS to the UE antenna connector as shown in Figure A.1.
- (2) A call is set up according to the Generic call setup procedure, and RF parameters are set up according to Table 5.9.2.
- (3) Enter the UE into loopback test mode and start the loopback test.

See [3] TS 34.108 and [4] TS 34.109 for details regarding generic call setup procedure and loopback test.

Table 5.9.2: Test parameters for UE spectrum emission mask

Parameter	Level / Status	Unit
Inner Loop Power Control	Enabled	
DTX mode	Off	

5.9.4.2 Procedure

- (1) Set and send continuously Up power control commands to the UE until the UE output power shall be maximum level.
- (2) Measure the power of the transmitted signal with a measurement filter of bandwidths according to Table 5.9.1. The characteristic of the filter shall be approximately Gaussian (typical spectrum analyzer filter). The center frequency of the filter shall be stepped in contiguous steps according to Table 5.9.1. The measured power shall be recorded for each step.
- (3) Measure the wanted output power according to Annex B.
- (4) Calculate the ratio of the power (2) with respect to (3) in dBc.

5.9.5 Test requirements

The result of 5.9.4.2 step (4) shall fulfil the requirements of Table 5.9.1.

5.10 Adjacent Channel Leakage Power Ratio (ACLR)

5.10.1 Definition and applicability

ACLR due to modulation is the ratio of the transmitted power to the power measured after a receiver filter in the adjacent channel(s) in the continuous transmission mode. Both the transmitted power and the received power are measured with a filter response that has a Root-Raised Cosine (RRC) filter response with roll-off $\alpha=0,22$ and a bandwidth equal to the chip rate.

The requirements and this test apply to all types of UTRA for the FDD UE.

5.10.2 Conformance requirements

The ACLR should be better than the value specified in Table 5.10.1.

Table 5.10.1: UE ACLR due to modulation

Power Class	UE channel	ACLR limit
3	+ 5 MHz or – 5 MHz	33 dB or –50 dBm which ever is higher
	+ 10 MHz or – 10 MHz	43 dB or –50 dBm which ever is higher
4	+ 5 MHz or – 5 MHz	33 dB or –50 dBm which ever is higher
	+ 10 MHz or – 10 MHz	43 dB or –50 dBm which ever is higher

The reference for this requirement is [1] TS 25.101 subclause 6.6.2.2.1.

5.10.3 Test purpose

To verify that the UE ACLR due to modulation does not exceed prescribed limit shown in Table 5.10.1.

Excess ACLR increase the interference to other channels or to other systems.

5.10.4 Method of test

5.9.4.1 Initial conditions

- (1) Connect the SS to the UE antenna connector as shown in Figure A.1.
- (2) A call is set up according to the Generic call setup procedure, and RF parameters are set up according to Table 5.10.2.
- (3) Enter the UE into loopback test mode and start the loopback test.

See [3] TS 34.108 and [4] TS 34.109 for details regarding generic call setup procedure and loopback test.

Table 5.10.2: Test parameters for Leakage Power due to Modulation

Parameter	Level / Status	Unit
Inner Loop Power Control	Enabled	
DTX mode	Off	

5.10.4.2 Procedure

- (1) Set and send continuously Up power control commands to the UE until the UE output power shall be maximum level.
- (2) Measure the power within the bandwidth of current carrier through a matched filter (RRC 0.22).
- (3) Measure the power fallen in the bandwidth of the first adjacent channels and the second adjacent channels through a matched filter (RRC 0.22).
- (4) Calculate the ratio of the power between the values measured in '(2)'and '(3)'.

5.10.5 Test requirements

The measured ACLR, derived in step (3) and (4), shall not exceed the limit in Table 5.10.1.

5.11 Spurious Emissions

5.11.1 Definition and applicability

Spurious emissions are emissions which are caused by unwanted transmitter effects such as harmonics emission, parasitic emission, intermodulation products and frequency conversion products, but exclude out of band emissions.

The frequency boundary and the detailed transitions of the limits between the requirement for out band emissions and spectrum emissions are based on ITU-R Recommendations SM.329.

The requirements and this test apply to all types of UTRA for the FDD UE.

5.11.2 Conformance requirements

Table 5.11.1a: General spurious emissions requirements

Frequency Bandwidth	Resolution Bandwidth	Minimum requirement
$9 \text{ kHz} \leq f < 150 \text{ kHz}$	1 kHz	-36 dBm
$150 \text{ kHz} \leq f < 30 \text{ MHz}$	10 kHz	-36 dBm
$30 \text{ MHz} \leq f < 1000 \text{ MHz}$	100 kHz	-36 dBm
$1 \text{ GHz} \leq f < 12,75 \text{ GHz}$	1 MHz	-30 dBm

Table 5.11.1b: Additional spurious emissions requirements

Frequency Bandwidth	Resolution Bandwidth	Minimum requirement
$1893,5 \text{ MHz} < f < 1919,6 \text{ MHz}$	300 kHz	-41 dBm
$925 \text{ MHz} \leq f \leq 935 \text{ MHz}$	100 kHz	-67 dBm *
$935 \text{ MHz} < f \leq 960 \text{ MHz}$	100 kHz	-79 dBm *
$1805 \text{ MHz} \leq f \leq 1880 \text{ MHz}$	100 kHz	-71 dBm *

*NOTE: The measurements are made on frequencies which are integer multiples of 200 kHz. As exceptions, up to five measurements with a level up to the applicable requirements defined in Table 5.11.1a are permitted for each UARFCN used in the measurement.

The reference for this requirement is [1] TS 25.101 subclause 6.6.3.1.

5.11.3 Test purpose

To verify that the UE spurious emissions do not exceed described value shown in Table 5.11.1a and Table 5.11.1b.

Excess spurious emissions increase the interference to other systems.

5.11.4 Method of test

5.11.4.1 Initial conditions

- (1) Connect the SS to the UE antenna connector as shown in Figure A.1.
- (2) A call is set up according to the Generic call setup procedure, and RF parameters are set up according to Table 5.11.2.
- (3) Enter the UE into loopback test mode and start the loopback test.

See [3] TS 34.108 and [4] TS 34.109 for details regarding generic call setup procedure and loopback test.

Table 5.11.2: Test parameters for Spurious Emissions

Parameter	Level / Status	Unit
Inner Loop Power Control	Enabled	

5.11.4.2 Procedure

- (1) Set and send continuously Up power control commands to the UE until the UE output power shall be maximum level.
- (2) Sweep the spectrum analyzer (or equivalent equipment) over a frequency range and measure the average power of spurious emission.

5.11.5 Test requirements

The measured average power of spurious emission, derived in step (2), shall not exceed the described value in Table 5.11.1a and 5.11.1b.

5.12 Transmit Intermodulation

5.12.1 Definition and applicability

The transmit intermodulation performance is a measure of the capability of the transmitter to inhibit the generation of signals in its non linear elements caused by presence of the wanted signal and an interfering signal reaching the transmitter via the antenna.

UE(s) transmitting in close vicinity of each other can produce intermodulation products, which can fall into the UE, or BS receive band as an unwanted interfering signal. The UE transmit intermodulation attenuation is defined by the ratio of the output power of the wanted signal to the output power of the intermodulation product when an interfering CW signal is added at a level below the wanted signal. Both the wanted signal power and the IM product power are measured with a filter that has a Root-Raised Cosine (RRC) filter response with roll-off $\alpha = 0,22$ and a bandwidth equal to the chip rate.

The requirements and this test apply to all types of UTRA for the FDD UE.

5.12.2 Conformance requirements

The UE transmit intermodulation shall not exceed the described value in Table 5.12.1.

Table 5.12.1: Transmit Intermodulation

CW Signal Frequency Offset from Transmitting Carrier	5MHz	10MHz
Interference CW Signal Level	-40 dBc	
Intermodulation Product	-31 dBc	-41 dBc

The reference for this requirement is [1] TS 25.101 subclause 6.7.1.

5.12.3 Test purpose

To verify that the UE transmit intermodulation does not exceed the described value in Table 5.12.1.

An excess transmit intermodulation increases transmission errors in the up link own channel when other transmitter exists nearby.

5.12.4 Method of test

5.12.4.1 Initial conditions

- (1) Connect the SS to the UE antenna connector as shown in Figure A.2.
- (2) A call is set up according to the Generic call setup procedure, and RF parameters are set up according to Table 5.12.2.
- (3) Enter the UE into loopback test mode and start the loopback test.

See [3] TS 34.108 and [4] TS 34.109 for details regarding generic call setup procedure and loopback test.

Table 5.12.2: Test parameters for Transmit Intermodulation

Parameter	Level / Status	Unit
Inner Loop Power Control	Enabled	

5.12.4.2 Procedure

- (1) Set and send continuously Up power control commands to the UE until the UE output power shall be maximum level.
- (2) Set the frequency of the CW generator to the offset 1 or offset 2 as shown in Table 5.12.1.
- (3) Measure the average output power of the UE by spectrum analyzer (or equivalent equipment) through RRC filter.
- (4) Search the intermodulation product signal, then measure the average power of transmitting intermodulation through RRC filter, and calculate the ratio to the average output power of UE.
- (5) Repeat the measurement with another tone offset.

5.12.5 Test requirements

The measured average power of transmit intermodulation, derived in step (4), shall not exceed the described value in Table 5.12.1.

5.13 Transmit Modulation

5.13.1 Modulation Accuracy

5.13.1.1 Definition and applicability

The modulation accuracy is a measure of the difference between the measured waveform and the theoretical modulated waveform (the error vector). It is the square root of the ratio of the mean error vector power to the mean reference signal power expressed as a %. The measurement interval is one power control group (timeslot).

The requirements and this test apply to all types of UTRA for the FDD UE.

5.13.1.2 Conformance requirements

The modulation accuracy shall not exceed 17,5 % at the maximum output power.

The reference for this requirement is [1] TS 25.101 clause 6.8.2.1.

5.13.1.3 Test purpose

To verify that the UE modulation accuracy does not exceed 17,5 % at the maximum output power.

An excess modulation error increases transmission errors in the up link own channel.

5.13.1.4 Method of test

5.13.1.4.1 Initial conditions

- (1) Connect the SS to the UE antenna connector as shown in Figure A.1.
- (2) A call is set up according to the Generic call setup procedure, and RF parameters are set up according to Table 5.13.1.
- (3) Enter the UE into loopback test mode and start the loopback test.

See [3] TS 34.108 and [4] TS 34.109 for details regarding generic call setup procedure and loopback test.

Table 5.13.1: Test parameters for Modulation Accuracy

Parameter	Level / Status	Unit
Output power	UE maximum power	dBm
Inner Loop Power Control	Enabled	

5.13.1.4.2 Procedure

- (1) Set and send continuously Up power control commands to the UE until the UE output power shall be maximum level.
- (2) Measure the EVM using Global In-Channel Tx-Test (Annex B).

5.13.1.5 Test requirements

The measured EVM, derived in step (2), shall not exceed 17,5%.

5.13.2 Peak code Domain error

5.13.2.1 Definition and applicability

The code domain error is computed by projecting the error vector power onto the code domain at the maximum spreading factor. The error vector for each power code is defined as the ratio to the mean power of the reference waveform expressed in dB. The peak code domain error is defined as the maximum value for the code domain error. The measurement interval is one power control group (timeslot).

The requirements and this test apply only to the UE in which the multi-code transmission is provided.

5.13.2.2 Conformance requirements

The peak code domain error shall not exceed [] dB.

The reference for this requirement is [1] TS 25.101 subclause 6.8.3.1.

5.13.2.3 Test purpose

To verify that the UE peak code domain error does not exceed [] dB.

An excess peak code domain error increases transmission errors in the up link own channel.

5.13.2.4 Method of test

5.13.2.4.1 Initial conditions

- (1) Connect the SS to the UE antenna connector as shown in Figure A.1.
- (2) A call is set up according to the Generic call setup procedure, and RF parameters are set up according to Table 5.13.2.
- (3) Enter the UE into loopback test mode and start the loopback test.

See [3] TS 34.108 and [4] TS 34.109 for details regarding generic call setup procedure and loopback test.

Table 5.13.2: Test parameters for Peak code Domain error

Parameter	Level / Status	Unit
Output power	UE maximum power	dBm
Uplink signal	multi-code	
Inner Loop Power Control	Enabled	

5.13.2.4.2 Procedure

- (1) Set and send continuously Up power control commands to the UE until the UE output power shall be maximum level.
- (2) Measure the Peak code Domain error using Global In-Channel Tx-Test (Annex B).

5.13.2.5 Test requirements

The measured Peak code Domain error, derived in step (2), shall not exceed [] dB.

6 Receiver Characteristics

6.1 General

Receiving performance test of the UE is implemented during communicating with the SS via air interface. The procedure is used normal call protocol until the UE is communicating on traffic channel basically. On the traffic channel, the UE provides special function for testing that is called Logical Test Interface and the UE is tested using this function (Refer to TS 34.109 Logical Test Interface (FDD) Special conformance testing functions)

Transmitting or receiving bit/symbol rate for test channel is shown in Table 6.1.

Table 6.1: Bit / Symbol rate for Test Channel

Type of User Information	User bit rate	DL DPCH symbol rate	UL DPCH bit rate	Remarks
12,2 kbps reference measurement channel	12,2 kbps	30 ksps	60 kbps	Standard Test

Unless otherwise stated the receiver characteristics are specified at the antenna connector of the UE. For UE(s) with an integral antenna only, a reference antenna with a gain of 0 dBi is assumed. UE with an integral antenna may be taken into account by converting these power levels into field strength requirements, assuming a 0 dBi gain antenna. Receiver characteristics for UE(s) with multiple antennas/antenna connectors are FFS.

The UE antenna performance has a significant impact on system performance, and minimum requirements on the antenna efficiency are therefore intended to be included in future versions of this specification. It is recognized that different requirements and test methods are likely to be required for the different types of UE.

All the parameters in clause 6 are defined using the DL reference measurement channel (12,2 kbps) specified in subclause C.3.1

The common RF test conditions are defined in Annex E, and each test conditions in this clause should refer Annex E. An individual test conditions are defined in the paragraph of each test.

6.2 Reference Sensitivity Level

6.2.1 Definition and applicability

The reference sensitivity is the minimum receiver input power measured at the antenna port at which the Bit Error Ratio (BER) does not exceed a specific value

The requirements and this test apply to all types of UTRA for the FDD UE.

6.2.2 Conformance requirements

The BER shall not exceed 0.001 for the parameters specified in Table 6.2.

The reference for this requirement is [1] TS 25.101 subclause 7.3.1.

6.2.3 Test purpose

To verify that the UE BER does not exceed 0.001 for the parameters specified in Table 6.2.

The lack of the reception sensitivity decreases the coverage area at the far side from BS.

6.2.4 Method of test

6.2.4.1 Initial conditions

- (1) Connect the SS to the UE antenna connector as shown in Figure A.3.
- (2) A call is set up according to the Generic call setup procedure, and RF parameters are set up according to Table 6.2.
- (3) Enter the UE into loopback test mode and start the loopback test.

See [3] TS 34.108 and [4] TS 34.109 for details regarding generic call setup procedure and loopback test.

Table 6.2: Test parameters for Reference Sensitivity Level

Parameter	Level / Status	Unit
\hat{I}_{or}	-106,7	dBm / 3,84 MHz
DPCH_Ec	-117	dBm / 3,84 MHz
Tx output power	UE maximum power	

6.2.4.2 Procedure

- (1) Set and send continuously Up power control commands to the UE until the UE output power shall be maximum level.
- (2) Measure the BER of DCH received from the UE at the SS.

6.2.5 Test requirements

The measured BER, derived in step (2), shall not exceed 0,001.

6.3 Maximum Input Level

6.3.1 Definition and applicability

This is defined as the maximum receiver input power at the UE antenna port which does not degrade the specified BER performance.

The requirements and this test apply to all types of UTRA for the FDD UE.

6.3.2 Conformance requirements

The BER shall not exceed 0.001 for the parameters specified in Table 6.3.

The reference for this requirement is [1] TS 25.101 subclause 7.4.1.

NOTE: Since the spreading factor is large ($10\log(\text{SF})=21\text{dB}$), the majority of the total input signal consists of the OCNS interference.

6.3.3 Test purpose

To verify that the UE BER does not exceed 0.001 for the parameters specified in Table 6.3.

The lack of the maximum input level decreases the coverage area at the near side from BS.

6.3.4 Method of test

6.3.4.1 Initial conditions

- (1) Connect the SS to the UE antenna connector as shown in Figure A.3.
- (2) A call is set up according to the Generic call setup procedure, and RF parameters are set up according to Table 6.3.
- (3) Enter the UE into loopback test mode and start the loopback test.

See [3] TS 34.108 and [4] TS 34.109 for details regarding generic call setup procedure and loopback test.

Table 6.3: Test parameters for Maximum Input Level

Parameter	Level / Status	Unit
\hat{I}_{or}	-25	dBm / 3,84MHz
$\frac{DPCH - E_c}{I_{or}}$	-19	dB

6.3.4.2 Procedure

- (1) Measure the BER of DCH received from the UE at the SS.

6.3.5 Test requirements

The measured BER, derived in step (1), shall not exceed 0,001.

6.4 Adjacent Channel Selectivity (ACS)

6.4.1 Definition and applicability

Adjacent Channel Selectivity (ACS) is a measure of a receiver's ability to receive a W-CDMA signal at its assigned channel frequency in the presence of an adjacent channel signal at a given frequency offset from the center frequency of the assigned channel. ACS is the ratio of the receive filter attenuation on the assigned channel frequency to the receive filter attenuation on the adjacent channel(s).

The requirements and this test apply to all types of UTRA for the FDD UE.

6.4.2 Conformance requirements

For the UE of power class 3 and 4, the BER shall not exceed 0.001 for the parameters specified in Table 6.4. This test condition is equivalent to the ACS value 33 dB.

The reference for this requirement is [1] TS 25.101 subclause 7.5.1.

6.4.3 Test purpose

To verify that the UE BER does not exceed 0,001 for the test parameters specified in Table 6.4.

The lack of the ACS decreases the coverage area when other transmitter exists in the adjacent channel.

6.4.4 Method of test

6.4.4.1 Initial conditions

- (1) Connect the SS to the UE antenna connector as shown in Figure A.4.
- (2) A call is set up according to the Generic call setup procedure, and RF parameters are set up according to Table 6.4.
- (3) Enter the UE into loopback test mode and start the loopback test.

See [3] TS 34.108 and [4] TS 34.109 for details regarding generic call setup procedure and loopback test.

Table 6.4: Test parameters for Adjacent Channel Selectivity

Parameter	Level / Status	Unit
DPCH_Ec	-103	dBm / 3,84 MHz
\hat{I}_{or}	-92,7	dBm / 3,84 MHz
I_{oac} (modulated)	-52	dBm / 3,84 MHz
F_{uw} (offset)	-5 or +5	MHz

6.4.4.2 Procedure

- (1) Set the parameters of the interference signal generator as shown in Table 6.4.
- (2) Measure the BER of DCH received from the UE at the SS.

6.4.5 Test requirements

The measured BER, derived in step (1), shall not exceed 0,001.

6.5 Blocking Characteristics

6.5.1 Definition and applicability

The blocking characteristic is a measure of the receiver's ability to receive a wanted signal at its assigned channel frequency in the presence of an unwanted interferer on frequencies other than those of the spurious response or the adjacent channels, without this unwanted input signal causing a degradation of the performance of the receiver beyond a specified limit. The blocking performance shall apply at all frequencies except those at which a spurious response occur.

The requirements and this test apply to all types of UTRA for the FDD UE.

6.5.2 Conformance requirements

The BER shall not exceed 0,001 for the parameters specified in Table 6.5.1 and Table 6.5.2. For Table 6.5.2 up to (24) exceptions are allowed for spurious response frequencies in each assigned frequency channel when measured using a 1 MHz step size.

The reference for this requirement is [1] TS 25.101 subclause 7.6.1.

6.5.3 Test purpose

To verify that the UE BER does not exceed 0.001 for the parameters specified in Table 6.5.1 and Table 6.5.2. For Table 6.5.2 up to (24) exceptions are allowed for spurious response frequencies in each assigned frequency channel when measured using a 1 MHz step size.

The lack of the blocking ability decreases the coverage area when other transmitter exists (except in the adjacent channels and spurious response).

6.5.4 Method of test

6.5.4.1 Initial conditions

- (1) Connect the SS to the UE antenna connector as shown in Figure A.5.
- (2) A call is set up according to the Generic call setup procedure, and RF parameters are set up according to Table 6.5.1 and Table 6.5.2.
- (3) Enter the UE into loopback test mode and start the loopback test.

See [3] TS 34.108 and [4] TS 34.109 for details regarding generic call setup procedure and loopback test.

Table 6.5.1: Test parameters for In-band blocking characteristics

Parameter	10 MHz offset	15 MHz offset	Unit
DPCH_Ec	-114	-114	dBm / 3,84 MHz
I _{or}	-103,7	-103,7	dBm / 3,84 MHz
I _{blocking} (modulated)	-56	-44	dBm / 3,84 MHz
F _{uw} (offset)	+10 or -10	+15 or -15	MHz

Table 6.5.2: Test parameters for Out of band blocking characteristics

Parameter	Band 1	Band 2	Band 3	Unit
DPCH_Ec	-114	-114	-114	dBm / 3,84MHz
\hat{I}_{or}	-103,7	-103,7	-103,7	dBm / 3,84MHz
$I_{blocking}$ (CW)	-44	-30	-15	dBm
F_{uw} For operation in frequency bands as defined in subclause 4.2(a)	2050 < f < 2095 2185 < f < 2230	2025 < f < 2050 2230 < f < 2255	1 < f < 2025 2255 < f < 12750	MHz
F_{uw} For operation in frequency bands as defined in subclause 4.2(b)	1870 < f < 1915 2005 < f < 2050	1845 < f < 1870 2050 < f < 2075	1 < f < 1845 2075 < f < 12750	MHz

NOTE:

1. For operation in bands referenced in 4.2(a), from 2095 < f < 2110 MHz and 2170 < f < 2185 MHz, the appropriate in-band blocking or adjacent channel selectivity in subclause 6.4.2 shall be applied.
2. For operation in bands referenced in 4.2(b), 1915 < f < 1930 MHz and 1990 < f < 2005 MHz, the appropriate in-band blocking or adjacent channel selectivity in subclause 6.4.2 shall be applied.

6.5.4.2 Procedure

- (1) Set the parameters of the CW generator or the interference signal generator as shown in Table 6.5.1 and Table 6.5.2.
- (2) Measure the BER of DCH received from the UE at the SS.

6.5.5 Test requirements

The measured BER, derived in step (2), shall not exceed 0,001.

6.6 Spurious Response

6.6.1 Definition and applicability

Spurious response is a measure of the receiver's ability to receive a wanted signal on its assigned channel frequency without exceeding a given degradation due to the presence of an unwanted CW interfering signal at any other frequency at which a response is obtained i.e. for which the blocking limit is not met.

The requirements and this test apply to all types of UTRA for the FDD UE.

6.6.2 Conformance requirements

The BER shall not exceed 0,001 for the parameters specified in Table 6.6.1.

The reference for this requirement is [1] TS 25.101 subclause 7.7.1.

6.6.3 Test purpose

To verify that the UE BER does not exceed 0,001 for the parameters specified in Table 6.6.1.

The lack of the spurious response ability decreases the coverage area when other unwanted interfering signal exists at any other frequency.

6.6.4 Method of test

6.6.4.1 Initial conditions

- (1) Connect the SS to the UE antenna connector as shown in Figure A.6.
- (2) A call is set up according to the Generic call setup procedure, and RF parameters are set up according to Table 6.6.1.
- (3) Enter the UE into loopback test mode and start the loopback test.

See [3] TS 34.108 and [4] TS 34.109 for details regarding generic call setup procedure and loopback test.

Table 6.6.1: Test parameters for Spurious Response

Parameter	Level	Unit
DPCH_Ec	-114	dBm / 3,84MHz
\hat{I}_{or}	-103,7	dBm / 3,84MHz
$I_{blocking}(CW)$	-44	dBm
F_{uw}	Spurious response frequencies	MHz

6.6.4.2 Procedure

- (1) Set the parameter of the CW generator as shown in Table 6.6.1.
- (2) Measure the BER of DCH received from the UE at the SS.

6.6.5 Test requirements

The measured BER, derived in step (2), shall not exceed 0,001.

6.7 Intermodulation Characteristics

6.7.1 Definition and applicability

Third and higher order mixing of the two interfering RF signals can produce an interfering signal in the band of the desired channel. Intermodulation response rejection is a measure of the capability of the receiver to receive a wanted signal on its assigned channel frequency in the presence of two or more interfering signals which have a specific frequency relationship to the wanted signal.

The requirements and this test apply to all types of UTRA for the FDD UE.

6.7.2 Conformance requirements

The BER shall not exceed 0.001 for the parameters specified in Table 6.7.1.

The reference for this requirement is [1] TS 25.101 subclause 7.8.1.

6.7.3 Test purpose

To verify that the UE BER does not exceed 0,001 for the parameters specified in Table 6.7.1.

The lack of the intermodulation response rejection ability decreases the coverage area when two or more interfering signals, which have a specific frequency relationship to the wanted signal, exist.

6.7.4 Method of test

6.7.4.1 Initial conditions

- (1) Connect the SS to the UE antenna connector as shown in Figure A.7.
- (2) A call is set up according to the Generic call setup procedure, and RF parameters are set up according to Table 6.7.1.
- (3) Enter the UE into loopback test mode and start the loopback test.

See [3] TS 34.108 and [4] TS 34.109 for details regarding generic call setup procedure and loopback test.

Table 6.7.1: Test parameters for Intermodulation Characteristics

Parameter	Level	Unit
DPCH_Ec	-114	dBm / 3,84 MHz
\hat{I}_{or}	-103,7	dBm / 3,84 MHz
I_{ouw1} (CW)	-46	dBm
I_{ouw2} (modulated)	-46	dBm / 3,84 MHz
F_{uw1} (offset)	10	MHz
F_{uw2} (offset)	20	MHz

6.7.4.2 Procedure

- (1) Set the parameters of the CW generator and interference signal generator as shown in Table 6.7.1.
- (2) Measure the BER of DCH received from the UE at the SS.

6.7.5 Test requirements

The measured BER, derived in step (1), shall not exceed 0,001.

6.8 Spurious Emissions

6.8.1 Definition and applicability

The spurious emissions power is the power of emissions generated or amplified in a receiver that appear at the UE antenna connector.

The requirements and this test apply to all types of UTRA for the FDD UE.

6.8.2 Conformance requirements

The spurious emission shall be:

- (a) Less than -60 dBm / 3,84 MHz at the UE antenna connector, for frequencies within the UE receive band.
- (b) Less than -57 dBm / 100 kHz at the UE antenna connector, for frequencies band from 9 kHz to 1 GHz.
- (c) Less than -47 dBm / 100 kHz at the UE antenna connector, for frequencies band from 1 GHz to 12,75 GHz.

The reference for this requirement is [1] TS 25.101 subclause 7.9.1.

6.8.3 Test purpose

To verify that the UE spurious emission meets the specifications described in subclause 5.8.2.

Excess spurious emissions increase the interference to other systems.

6.8.4 Method of test

6.8.4.1 Initial conditions

- (1) Connect a spectrum analyzer (or other suitable test equipment) to the UE antenna connector as shown in Figure A.8.
- (2) Enable the UE receiver and set Cell Search Mode on a PCCPCH. Since there is no downlink signal, the UE should not pass the Cell Search mode.

6.8.4.2 Procedure

- (1) Sweep the spectrum analyzer (or other suitable test equipment) over a frequency range from the lowest intermediate frequency or lowest oscillator frequency used in the receiver or 1 MHz, whichever is lowest to at least 3 times the carrier frequency.

6.8.5 Test requirements

The all measured spurious emissions, derived in step (1), shall be:

- (a) Less than -60 dBm / 3,84 MHz at the UE antenna connector, for frequencies within the UE receive band.
- (b) Less than -57 dBm / 100 kHz at the UE antenna connector, for frequencies band from 9 kHz to 1 GHz.
- (c) Less than -47 dBm / 100 kHz at the UE antenna connector, for frequencies band from 1 GHz to 12,75 GHz.

7 Performance requirements

7.1 General

The performance requirements for the UE in this clause are specified for the measurement channels specified in Annex C and Table 7.1.1, the propagation conditions specified in 7.1.2 and the Down link Physical channels specified in Annex D.

The method for BLER measurement is specified in [3] TS 34.109.

Table 7.1.1: Bit / Symbol rate for Test Channel

Type of User Information	User bit rate	DL DPCH symbol rate	UL DPCH bit rate
12,2 kbps reference measurement channel	12,2 kbps	30 ksps	60 kbps
64/144/384 kbps reference measurement channel	64 kbps	120 ksps	240 kbps
	144 kbps	240 ksps	480 kbps
	384 kbps	480 ksps	960 kbps

Table 7.1.2: Summary of UE performance targets

Test Chs.	Information Data Rate	Static	Multi-path Case 1	Multi-path Case 2	Multi-path Case 3	Moving	Birth / Death
		Performance metric					
DCH	12,2 kbps	BLER<10 ⁻²	BLER<10 ⁻²	BLER<10 ⁻²	BLER<10 ⁻²	BLER<	BLER<
	64 kbps	BLER<10 ⁻¹ ,10 ⁻²	BLER<10 ⁻¹ ,10 ⁻²	BLER<10 ⁻¹ ,10 ⁻²	BLER<10 ⁻¹ ,10 ⁻² ,10 ⁻³	BLER<	BLER<
	144 kbps	BLER<10 ⁻¹ ,10 ⁻²	BLER<10 ⁻¹ ,10 ⁻²	BLER<10 ⁻¹ ,10 ⁻²	BLER<10 ⁻¹ ,10 ⁻² ,10 ⁻³	-	-
	384 kbps	BLER<10 ⁻¹ ,10 ⁻²	BLER<10 ⁻¹ ,10 ⁻²	BLER<10 ⁻¹ ,10 ⁻²	BLER<10 ⁻¹ ,10 ⁻² ,10 ⁻³	-	-

7.1.1 Measurement Configurations

In all measurements UE should transmit with maximum power while receiving signals from BS. Transmission Power Control is always disabled during the measurements. Chip Rate is specified to be 3,84 MHz.

It is assumed that fields inside DPCH have the same energy per PN chip. Also, if the power of SCCPCH is not specified in the test parameter table, it should be set to zero. The power of OCNS should be adjusted that the power ratios (E_c/I_{or}) of all specified forward channels add up to one.

Measurement configurations for different scenarios are shown in Figure A.9, Figure A.10 and Figure A.11.

7.2 Demodulation in Static Propagation conditions

7.2.1 Demodulation of Dedicated Channel (DCH)

7.2.1.1 Definition and applicability

The receive characteristic of the Dedicated Channel (DCH) in the static environment is determined by the block error ratio (BLER). BLER is specified for each individual data rate of the DCH. DCH is mapped into the Dedicated Physical Channel (DPCH).

The UE shall be tested only according to the data rate, supported. The data-rate-corresponding requirements shall apply to the UE.

7.2.1.2 Conformance requirements

For the parameters specified in Table 7.2.1.1 the BLER shall not exceed the piece-wise linear BLER curve specified by the points in Table 7.2.1.2.

Table 7.2.1.1: DCH parameters in static propagation conditions

Parameter	Test 1	Test 2	Test 3	Test 4	Test 5	Unit
\hat{I}_{or}/I_{oc}	-1					dB
I_{oc}	-60					dBm / 3,84 MHz
Information Data Rate	12,2	12,2	64	144	384	kbps
TFCI	off	on	on	on	on	-

Table 7.2.1.2: DCH requirements in static propagation conditions

Test Number	$\frac{DPCH - E_c}{I_{or}}$	BLER
1		10^{-2}
2	-16,6 dB	10^{-2}
3	-13,1 dB	10^{-1}
	-12,8 dB	10^{-2}
4	-9,9 dB	10^{-1}
	-9,8 dB	10^{-2}
5	-5,6 dB	10^{-1}
	-5,5 dB	10^{-2}

The reference for this requirement is [1] TS 25.101 subclause 8.2.3.1.

7.2.1.3 Test purpose

To verify the ability of the receiver to receive a predefined test signal, representing a static propagation channel for the wanted and for the co-channel signals from serving and adjacent cells, with a block error ratio (BLER) not exceeding a specified value.

7.2.1.4 Method of test

7.2.1.4.1 Initial conditions

1. Connect the SS and an AWGN noise source to the UE antenna connector as shown in Figure A.9.
2. Set up a call according to the Generic call setup procedure.
3. Set the test parameters for test 1-5 as specified in Table 7.2.1.1.
4. Enter the UE into loopback test mode and start the loopback test.

7.2.1.4.2 Procedures

1. Measure BLER of DCH.

7.2.1.5 Test requirements

For the parameters specified in Table 7.2.1.1 the BLER shall not exceed the associated piece-wise linear BLER curve specified by the points in Table 7.2.1.2.

7.3 Demodulation of DCH in Multi-path Fading Propagation conditions

7.3.1 Single Link Performance

7.3.1.1 Definition and applicability

The receive characteristics of the Dedicated Channel (DCH) in different multi-path fading environments are determined by the block error ratio (BLER) values. BLER is measured for the each of the individual data rate specified for the DPCH. DCH is mapped into in Dedicated Physical Channel (DPCH).

The UE shall be tested only according to the data rate, supported. The data-rate-corresponding requirements shall apply to the UE.

7.3.1.2 Conformance requirements

For the parameters specified in Table 7.3.1.1, 7.3.1.3 and 7.1.3.5 the BLER shall not exceed the associated piece-wise linear BLER curves specified by the points in Table 7.3.1.2, 7.3.1.4 and 7.3.1.6.

Table 7.3.1.1: Test Parameters for DCH in multi-path fading propagation conditions (Case 1)

Parameter	Test 1	Test 2	Test 3	Test 4	Test 5	Unit
\hat{I}_{or}/I_{oc}	9					dB
I_{oc}	-60					dBm / 3,84 MHz
Information Data Rate	12,2	12,2	64	144	384	kbps
TFCI	off	on	on	on	on	-

Table 7.3.1.2: Test requirements for DCH in multi-path fading propagation conditions (Case 1)

Test Number	$\frac{DPCH - E_c}{I_{or}}$	BLER
1		10^{-2}
2	-15,0 dB	10^{-2}
3	-13,9 dB	10^{-1}
	-10,0 dB	10^{-2}
4	-10,6 dB	10^{-1}
	-6,8 dB	10^{-2}
5	-6,3 dB	10^{-1}
	-2,2 dB	10^{-2}

Table 7.3.1.3: DCH parameters in multi-path fading propagation conditions (Case 2)

Parameter	Test 6	Test 7	Test 8	Test 9	Test 10	Unit
\hat{I}_{or}/I_{oc}	-3	-3	-3	3	6	dB
I_{oc}	-60					dBm / 3,84 MHz
Information Data Rate	12,2	12,2	64	144	384	kbps
TFCI	off	on	on	on	on	-

Table 7.3.1.4: DCH requirements in multi-path fading propagation conditions (Case 2)

Test Number	$\frac{DPCH - E_c}{I_{or}}$	BLER
6		10^{-2}
7	-7,7 dB	10^{-2}
8	-6,4 dB	10^{-1}
	-2,7 dB	10^{-2}
9	-8,1 dB	10^{-1}
	-5,1 dB	10^{-2}
10	-5,5 dB	10^{-1}
	-3,2 dB	10^{-2}

Table 7.3.1.5: DCH parameters in multi-path fading propagation conditions (Case 3)

Parameter	Test 11	Test 12	Test 13	Test 14	Test 15	Unit
\hat{I}_{or}/I_{oc}	-3	-3	-3	3	6	dB
I_{oc}	-60					dBm / 3,84 MHz
Information Data Rate	12,2	12,2	64	144	384	kbps
TFCI	off	on	on	on	on	-

Table 7.3.1.6: DCH requirements in multi-path fading propagation conditions (Case 3)

Test Number	$\frac{DPCH - E_c}{I_{or}}$	BLER
11		10^{-2}
12	-11,8 dB	10^{-2}
13	-8,1 dB	10^{-1}
	-7,4 dB	10^{-2}
	-6,8 dB	10^{-3}
14	-9,0 dB	10^{-1}
	-8,5 dB	10^{-2}
	-8,0 dB	10^{-3}
15	-6,0 dB	10^{-1}
	-5,5 dB	10^{-2}
	-5,0 dB	10^{-3}

The reference for this requirement is [1] TS 25.101 subclause 8.3.1.1.

7.3.1.3 Test purpose

To verify the ability of the receiver to receive a predefined test signal, representing a multi-path fading propagation channel for the wanted and for the co-channel signals from serving and adjacent cells, with a block error ratio (BLER) not exceeding a specified value.

7.3.1.4 Method of test

7.3.1.4.1 Initial conditions

1. Connect the SS, multipath fading simulator and an AWGN noise source to the UE antenna connector as shown in Figure A.10.
2. Set up a call according to the Generic call setup procedure.
3. Set the test parameters for test 1-15 as specified Table 7.3.1.1, Table 7.3.1.3 and Table 7.3.1.5.
4. Enter the UE into loopback test mode and start the loopback test.
5. Setup fading simulators as fading condition case 1 to 3 which are described in Table D.2.2.1

7.3.1.4.2 Procedures

1. Measure BLER of DCH.

7.3.1.5 Test requirements

For the parameters specified in Table 7.3.1.1, Table 7.3.1.3 and Table 7.3.1.5, the BLER shall not exceed the associated piece-wise linear BLER curve specified by the points in Table 7.3.1.2, Table 7.3.1.4 and Table 7.3.1.6.

7.4 Demodulation of DCH in Moving Propagation conditions

7.4.1 Single Link Performance

7.4.1.1 Definition and applicability

The receive single link performance of the Dedicated Traffic Channel (DCH) in dynamic moving propagation conditions are determined by the Block Error Ratio (BLER) values. BLER is measured for the each of the individual data rate specified for the DPCH. DCH is mapped into Dedicated Physical Channel (DPCH).

The UE shall be tested only according to the data rate, supported. The data-rate-corresponding requirements shall apply to the UE.

7.4.1.2 Conformance requirements

For the parameters specified in Table 7.4.1.1 the BLER shall not exceed the piece-wise linear BLER curve specified in points in Table 7.4.1.2.

Table 7.4.1.1: DCH parameters in moving propagation conditions

Parameter	Test 1	Test 2	Test 3	Unit
\hat{I}_{or}/I_{oc}	-1			dB
I_{oc}	-60			dBm / 3,84 MHz
Information Data Rate	12,2	12,2	64	kbps
TFCI	off	on	on	-

Table 7.4.1.2: DCH requirements in moving propagation conditions

Test Number	$\frac{DPCH_E_c}{I_{or}}$	BLER
1		
2		
3		

The reference for this requirement is [1] TS 25.101 subclause 8.4.1.1.

7.4.1.3 Test purpose

To verify the ability of the receiver to receive a predefined test signal, representing a moving propagation channel for the wanted and for the co-channel signals from serving and adjacent cells, with a block error ratio (BLER) not exceeding a specified value.

7.4.1.4 Method of test

7.4.1.4.1 Initial conditions

1. Connect the SS and an AWGN noise source to the UE antenna connector as shown in Figure A.10.
2. Set up a call according to the Generic call setup procedure.
3. Set the test parameters as specified in Table 7.4.1.1.
4. Enter the UE into loopback test mode and start the loopback test.
5. Setup fading simulator as moving propagation condition, which is described in Annex D.2.3.

7.4.1.4.2 Procedures

1. Measure BLER of DCH.

7.4.1.5 Test requirements

For the parameters specified in Table 7.4.1.1 the BLER shall not exceed the associated piece-wise linear BLER curve specified by the points in Table 7.4.1.2.

7.5 Demodulation of DCH in Birth-Death Propagation conditions

7.5.1 Single Link Performance

7.5.1.1 Definition and applicability

The receive single link performance of the Dedicated Traffic Channel (DCH) in dynamic birth-death propagation conditions are determined by the Block Error Ratio (BLER) values. BLER is measured for the each of the individual data rate specified for the DPCH. DCH is mapped into Dedicated Physical Channel (DPCH).

The UE shall be tested only according to the data rate, supported. The data-rate-corresponding requirements shall apply to the UE.

7.5.1.2 Conformance requirements

For the parameters specified in Table 7.5.1.1, the BLER shall not exceed the piece-wise linear BLER curve in the points in Table 7.5.1.2.

Table 7.5.1.1: DCH parameters in birth-death propagation conditions

Parameter	Test 1	Test 2	Test 3	Unit
\hat{I}_{or}/I_{oc}	-1			dB
I_{oc}	-60			dBm / 3,84 MHz
Information Data Rate	12,2	12,2	64	kbps
TFCI	off	on	on	-

Table 7.5.1.2: DCH requirements in birth-death propagation conditions

Test Number	$\frac{DPCH_E_c}{I_{or}}$	BLER
1		
2		
3		

The reference for this requirement is [1] TS 25.101 subclause 8.5.1.1.

7.5.1.3 Test purpose

To verify the ability of the receiver to receive a predefined test signal, representing a birth-death propagation channel for the wanted and for the co-channel signals from serving and adjacent cells, with a block error ratio (BLER) not exceeding a specified value.

7.5.1.4 Method of test

7.5.1.4.1 Initial conditions

1. Connect the SS and an AWGN noise source to the UE antenna connector as shown in Figure A.10.
2. Set up a call according to the Generic call setup procedure.
3. Set the test parameters as specified in Table 7.5.1.1.
4. Enter the UE into loopback test mode and start the loopback test.
5. Setup fading simulator as birth-death propagation condition, which is described in Annex D.2.4.

7.5.1.4.2 Procedures

1. Measure BLER of DCH.

7.5.1.5 Test requirements

For the parameters specified in Table 7.5.1.1 the BLER shall not exceed the associated piece-wise linear BLER curve specified by the points in Table 7.5.1.2.

7.6 Demodulation of DCH in Base Station Transmit diversity modes

7.6.1 Demodulation of DCH in open-loop transmit diversity mode

7.6.1.1 Definition and applicability

The receive characteristic of the Dedicated Channel (DCH) in open loop transmit diversity mode is determined by the Block Error Ratio (BLER). DCH is mapped into in Dedicated Physical Channel (DPCH).

The requirements and this test apply to all types of UTRA for the FDD UE.

7.6.1.2 Conformance requirements

For the parameters specified in Table 7.6.1.1 the BLER shall not exceed the associated piece-wise linear BLER curve specified by the points in Table 7.6.1.2.

Table 7.6.1.1: Test parameters for DCH reception in a open-loop transmit diversity scheme (Propagation condition: Case 1)

Parameter	Test 1	Unit
\hat{I}_{or}/I_{oc}	[]	dB
I_{oc}	-60	dBm / 3,84 MHz
Information data rate	12,2	kbps

Table 7.6.1.2: Test requirements for DCH reception in open-loop transmit diversity scheme

Test Number	$\frac{DPCH_E_c}{I_{or}}$ (antenna 1/2)	BLER
1		

The reference for this requirement is [1] TS 25.101 subclause 8.6.1.1.

7.6.1.3 Test purpose

To verify that UE reliably demodulates the DPCH of the BS while open loop transmit diversity is enabled during the connection.

7.6.1.4 Method of test

7.6.1.4.1 Initial conditions

- (1) Connect SS, multipath fading simulators and an AWGN source to the UE antenna connector as shown in Figure A.12.
- (2) Set up a call according to the Generic call setup procedure.
- (3) RF parameters are set up according to Table 7.6.1.1 and Table E 3.4.
- (4) Enter the UE into loopback test mode and start the loopback test.
- (5) Activate open loop Tx diversity function.
- (6) Set up fading simulators as fading condition case 1, which is described in Table D.2.2.1.

See [3] TS 34.108 and [4] TS 34.109 for details regarding generic call setup procedure and loopback test.

7.6.1.4.2 Procedure

- (1) Measure BLER in points specified in Table 7.6.1.2.

7.6.1.5 Test Requirements

For the parameters specified in Table 7.6.1.1 the BLER shall not exceed the associated piece-wise linear BLER curve specified by the points in Table 7.6.1.2.

7.6.2 Demodulation of DCH in closed loop transmit diversity mode

7.6.2.1 Definition and applicability

The receive characteristic of the dedicated channel (DCH) in closed loop transmit diversity mode is determined by the Block Error Ratio (BLER). DCH is mapped into in Dedicated Physical Channel (DPCH).

The requirements and this test apply to all types of UTRA for the FDD UE.

7.6.2.2 Conformance requirements

For the parameters specified in Table 7.6.2.1 the BLER shall not exceed the associated piece-wise linear BLER curves specified by the points in Table 7.6.2.2.

Table 7.6.2.1: Test Parameters for DCH Reception in closed loop transmit diversity mode (Propagation condition: Case 1)

Parameter	Test 1 (Mode 1)	Test 2 (Mode 2)	Unit
\hat{I}_{or}/I_{oc}	[]	[]	dB
I_{oc}	-60	-60	dBm / 3,84 MHz
Information data rate	12,2	12,2	kbps
Feedback error ratio	4	4	%

Table 7.6.2.2: Test requirements for DCH reception in feedback transmit diversity mode

Test Number	$\frac{DPCH_E_c(1)}{I_{or}}$	BLER
1		
2		

The reference for this requirement is [1] TS 25.101 subclause 8.6.2.1.

7.6.2.3 Test purpose

To verify that UE reliably demodulates the DPCH of the BS while closed loop transmit diversity is enabled during the connection.

7.6.2.4 Method of test

7.6.2.4.1 Initial conditions

- (1) Connect SS, multipath fading simulators and an AWGN source to the UE antenna connector as shown in Figure A.12.
- (2) Set up a call according to the Generic call setup procedure.
- (3) RF parameters are set up according to Table 7.6.2.1 and Table E 3.5.
- (4) Enter the UE into loopback test mode and start the loopback test.
- (5) Activate closed loop Tx diversity function.
- (6) Set up fading simulators as fading condition case 1, which is described in Table D.2.2.1.

See [3] TS 34.108 and [4] TS 34.109 for details regarding generic call setup procedure and loopback test.

7.6.2.4.2 Procedure

- (1) Measure BLER in points specified in Table 7.6.2.2.

7.6.2.5 Test Requirements

For the parameters specified in Table 7.6.2.1 the BLER shall not exceed the associated piece-wise linear BLER curve specified by the points in Table 7.6.2.2.

7.6.3 Demodulation of DCH in Site Selection Diversity Transmission mode

7.6.3.1 Definition and applicability

The bit error characteristics of UE receiver is determined in Site Selection Diversity Transmission (SSDT) mode. Two BS emulators are required for this performance test. The delay profiles of signals received from different base stations are assumed to be the same but time shifted by 10 chip periods.

The requirements and this test apply to all types of UTRA for the FDD UE.

¹ This is the total power from both antennas. Power sharing between antennas are closed loop mode dependent as specified in TS25.214

7.6.3.2 Conformance requirements

For the parameters specified in Table 7.6.3.1, the BLER shall not exceed the piece-wise linear BLER curve specified by the points in Table 7.6.3.2.

**Table 7.6.3.1: DCH parameters in multi-path propagation conditions during SSDT mode
(Propagation condition: Case 1)**

Parameter	Test 1	Test 2	Test 3	Test 4	Unit
$\frac{CPICH - E_c}{I_{or}}$ (for Cell 1)	-10	-13	-10	-10	dB
$\frac{CPICH - E_c}{I_{or}}$ (for Cell 2)	-10	-10	-10	-10	dB
$\frac{DPCH - E_{c1}}{I_{or}} / \frac{DPCH - E_{c2}}{I_{or}}$ *	0	-3	0	+3	dB
\hat{I}_{or1} / I_{oc}	9	6	9	9	dB
\hat{I}_{or2} / I_{oc}	9	9	9	6	dB
I_{oc}	-60				dBm / 3,84 MHz
Information Data Rate	12,2	12,2	12,2	12,2	kbps
Number of FBI bits assigned to "S" Field	1	1	2	2	
Code word Set	Long	Long	Short	Short	

*NOTE: $DPCH - E_c / I_{or}$ value applies whenever DPDCH in the cell is transmitted.

Table 7.6.3.2: DCH requirements in multi-path propagation conditions during SSDT Mode

Test Number	$\frac{DPCH - E_c}{I_{or}}$	BLER
1		10^{-1}
		10^{-2}
2		10^{-1}
		10^{-2}
3		10^{-1}
		10^{-2}
4		10^{-1}
		10^{-2}

The reference for this requirement is [1] TS 25.101 subclause 8.6.3.1.

7.6.3.3 Test purpose

To verify that UE reliably demodulates the DPCH of the selected BS while site selection diversity is enabled during soft handover.

7.6.3.4 Method of test

7.6.3.4.1 Initial conditions

- (1) Connect two SS's, multipath fading simulators and an AWGN source to the UE antenna connector as shown in Figure A.11.
- (2) Set up a call according to the Generic call setup procedure, and RF parameters are set up according to Table 7.6.3.1 and Table 7.6.3.2.
- (3) Enter the UE into loopback test mode and start the loopback test.
- (4) Activate SSDT function.
- (5) Set up fading simulators as fading condition case 1, which is described in Table D.2.2.1.

7.6.3.4.2 Procedure

Measure BLER of DCH.

7.6.3.5 Test Requirements

BLER shall not exceed the piece-wise linear BLER curve specified by the points in Table 7.6.3.2.

7.7 Demodulation in Handover conditions

7.7.1 Inter-Cell Soft Handover Performance

7.7.1.1 Definition and applicability

The bit error ratio characteristics of UE is determined during an inter-cell soft handover. During the soft handover a UE receives signals from different Base Stations. A UE has to be able to demodulate two PCCPCH channels and to combine the energy of DCH channels. Delay profiles of signals received from different Base Stations are assumed to be the same but time shifted by 10 chips.

The receive characteristics of the different channels during inter-cell handover are determined by the block error ratio (BLER) values.

The UE shall be tested only according to the data rate, supported. The data-rate-corresponding requirements shall apply to the UE.

7.7.1.2 Conformance requirements

For the parameters specified in Table 7.7.1.1, the BLER shall not exceed the piece-wise linear BLER curve specified by the points in Table 7.7.1.2

Table 7.7.1.1: DCH parameters in multi-path propagation conditions during Soft Handoff (Case 3)

Parameter	Test 1	Test 2	Test 3	Test 4	Test 5	Unit
\hat{I}_{or1}/I_{oc} and \hat{I}_{or2}/I_{oc}	0	0	0	3	6	dB
I_{oc}						dBm / 3,84 MHz
Information Data Rate	12,2	12,2	64	144	384	kbps
TFCI	off	on	on	on	on	-

Table 7.7.1.2: DCH requirements in multi-path propagation conditions during Soft Handoff (Case 3)

Test Number	$\frac{DPCH_E_c}{I_{or}}$	BLER
1		
2		
3		
4		
5		

The reference for this requirement is [1] TS 25.101 subclause 8.7.1.1.

7.7.1.3 Test purpose

To verify that the BLER does not exceed the piece-wise linear BLER curve specified by the points in Table 7.7.1.2.

7.7.1.4 Method of test

7.7.1.4.1 Initial conditions

[TBD]

7.7.1.4.2 Procedures

- (1) Connect the SS, multipath fading simulator and an AWGN noise source to the UE antenna connector as shown in Figure A.11.
- (2) Set up the call.
- (3) Set the test parameters for test 1-5 as specified in Table 7.7.1.1.
- (4) Count, at the SS, the number of information blocks transmitted and the number of correctly received information blocks at the UE.
- (5) Measure BLER of DCH channel.

7.7.1.5 Test requirements

[TBD]

7.8 Inner loop power control in downlink

7.8.1 Definition and applicability

Performance of the inner loop power control in downlink is determined by the Block Error Ratio (BLER) values and by the measured average transmitted $DPCH_E_c/I_{or}$ value.

The requirements and this test apply to all types of UTRA for the FDD UE.

7.8.2 Conformance requirements

For the parameters specified in Table 7.8.1, the BLER and $DPCH_{E_c}/I_{or}$ value shall not exceed the values specified in Table 7.8.2.

NOTE:

1. Power control is ON during the test.
2. Power control step size is 1 dB.

Table 7.8.1: Test parameters for downlink inner loop power control

Parameter	Test 1	Test 2	Unit
\hat{I}_{or}/I_{oc}	9	-1	dB
I_{oc}	-60	-60	dBm / 3,84 MHz
Information Data Rate	12,2	12,2	kbps
TFCI	on	on	-
Propagation Conditions	Case 4	Case 4	
SIR target	FFS	FFS	

Table 7.8.2: Requirements in downlink inner loop power control

Parameter	Test 1	Test 2	Unit
$\frac{DPCH_{E_c}}{I_{or}}$	FFS	FFS	dB
BLER on TCH	0.01	0.01	
Confidence level for $\frac{DPCH_{E_c}}{I_{or}}$			%

The reference for this requirement is [1] TS 25.101 subclause 8.8.1.1.

7.8.3 Test purpose

The purpose of the test is to verify that the UE power control is performing correctly and the average power required from BS is below defined value.

7.8.4 Method of test

7.8.4.1 Initial conditions

- (1) Connect the SS to the UE antenna connector as shown in Figure A.9.
- (2) A call is set up according to the Generic call set procedure using parameters as specified in Table 7.8.1.
- (3) Enter the UE into loopback test mode and start the loopback test.

See [3] TS 34.108 and [4] TS 34.109 for details regarding generic call setup procedure and loopback test.

7.8.4.2 Procedure

- (1) SS signals the required BLER value to a UE. Outer loop PC and Inner loop PC are working in a UE.
- (2) TPC command in uplink must be error free. This is made by sending TPC command in downlink to raise UE uplink power to the level that TPC commands in uplink are received correctly at the SS.

- (3) SS obeys TPC commands received in uplink.
- (4) After UE has achieved the target BLER value the outer loop PC is switched off. In this moment a UE has set its target SIR value to be such that the UE is able to achieve the required BLER value.
- (5) The average power of transmitted DPCH_Ec/I_{or} power is measured at the SS. At the same time an average BLER must be below the target BLER.
- (6) The measured DPCH_Ec/I_{or} is compared to specific value.

7.8.5 Test Requirements

- (a) The average DPCH_Ec/I_{or} power does not exceed the values in Table 7.8.2.
- (b) The average BLER does not exceed the values in Table 7.8.2.

7.9 Outer loop power control in downlink

7.9.1 Definition and applicability

Outer loop power control in the downlink is the ability of the UE receiver to maintain the suitable target for the inner loop closed loop PC according to the required link quality set by the network.

The requirements and this test apply to all types of UTRA for the FDD UE.

7.9.2 Conformance requirements

For the parameters specified in Table 7.9.1 the downlink $\frac{DPCH_Ec}{I_{or}}$ power shall be below the specified value and the reported quality value shown in Table 7.9.2.

NOTE:

1. Power control is ON during the test.
2. The averaging time T shall be long enough to minimize the previous quality target impact to the result.

Table 7.9.1: Test parameter for downlink outer loop power control

Parameter	Test 1	Test 2	Unit
\hat{I}_{or}/I_{oc}	5		dB
I_{oc}	-60		dBm / 3,84 MHz
Information Data Rate	12,2		kbps
TFCI	On		-
Reporting delay, or averaging period, T	[]	[]	ms
Propagation condition	Case 4		

Table 7.9.2: Requirements in downlink outer loop power control

Parameter	Test 1	Test 2	Unit
$\frac{DPCH_Ec}{I_{or}}$	[max. needed channel power]	[max. needed channel power]	dB
Target quality value	FFS	FFS	
Reported quality value			
Confidence level			

The reference for this requirement is [1] TS 25.101 subclause 8.9.1.1.

7.9.3 Test purpose

Outer loop power control in the downlink is the ability of the UE receiver to maintain the suitable target for the inner loop closed loop PC according to the required link quality set by the network.

7.9.4 Method of test

7.9.4.1 Initial conditions

- (1) Connect the SS to the UE antenna connector as shown in Figure A.9.
- (2) A call is set up according to the Generic call set procedure using parameters as specified in Table 7.9.1.
- (3) Enter the UE into loopback test mode and start the loopback test.

See [3] TS 34.108 and [4] TS 34.109 for details regarding generic call setup procedure and loopback test.

7.9.4.2 Procedure

- (1) Static fading propagation condition is assumed during the test.
- (2) SS signals to UE the target [BLER] as the required link quality. The closed loop PC is enabled and SS will vary the physical channel power on downlink according to the TPC commands from UE until the target [BLER] value is met, within the minimum accuracy requirement. When the initial operating point has been achieved, the average E_c/I_{or} is recorded.
- (3) SS signals to UE a new [BLER] target. UE starts inner loop power control according to the new outer loop target, and based on TPC bits. After time period T the new target has been achieved, within the minimum accuracy requirement. UE reports [BLER] value to the test equipment in uplink signalling messages. The average E_c/I_{or} is then recorded.
- (4) This procedure is repeated until adequate amount of [BLER] measurement results over the different service requirements have been measured.

7.9.5 Test Requirements

[TBD]

7.10 Downlink compressed mode

Downlink compressed mode is used to create gaps in the downlink transmission, to allow the UE to make measurements on other frequencies.

7.10.1 Single link performance

7.10.1.1 Definition and applicability

The receiver single link performance of the Dedicated Traffic Channel (DCH) in compressed mode is determined by the Block Error Ratio (BLER), average power in the downlink and the maximum power in the uplink.

The compressed mode parameters are given in clause C.4.

The requirements and this test apply to all types of UTRA for the FDD UE.

7.10.1.2 Conformance requirements

For the parameters specified in Table 7.10.1 the average downlink $\frac{DPCH - E_c}{I_{or}}$ power shall be below the specified value for the reported BLER shown in Table 7.10.2. The uplink DPDCH power shall be below the specified value.

NOTE:

1. Inner loop power control is ON during the test.

Table 7.10.1: Test parameter for downlink compressed mode

Parameter	Test 1	Unit
\hat{I}_{or}/I_{oc}	9	dB
I_{oc}	-60	dBm / 3,84 MHz
Information Data Rate	12,2	kbps
TFCI	On	-
Propagation condition	Case 2	

Table 7.10.2: Requirements in downlink compressed mode

Parameter	Test 1	Unit
$\frac{DPCH_E_c}{I_{or}}$		dB
Target quality		
Downlink BLER		
Uplink DPDCH	[Maximum power / slot]	dBm
Confidence level		%

The reference for this requirement is [1] TS 25.101 subclause 8.10.1.1.

7.10.1.3 Test purpose

It is the purpose of the test, to verify, that, due to temporary dynamic re-organisation of certain parameters in the DL compressed mode the BLER at the UE is preserved.

As the inner loop power control is running, controlling the DL power, it is furtheron verified, whether the preserved BLER is achieved by a sufficient low average DL power.

7.10.1.4 Method of test

7.10.1.4.1 Initial conditions

[TBD]

7.10.1.4.2 Procedure

[TBD]

7.10.1.5 Test requirements

[TBD]

8 Requirements for support of RRM

8.1 General

8.2 Idle Mode Tasks

8.2.1 Introduction

8.2.2 RF Cell Selection Scenario

8.2.2.1 Requirements for Cell Selection Single carrier Single cell case

8.2.2.1.1 Cell Selection delay

8.2.2.1.2 Test Parameters

8.2.2.1.3 Performance Requirements

8.2.2.2 Requirements for Cell Selection multi carrier multi cell case

8.2.2.2.1 Cell selection delay

8.2.2.2.2 Test Parameters

8.2.2.2.3 Performance Requirements

8.2.3 RF Cell Re-Selection Scenario

8.2.3.1 Requirements for Cell Re-Selection single carrier multi cell case

8.2.3.1.1 Cell re-selection delay

8.2.3.1.2 Test Parameters

8.2.3.1.3 Performance Requirements

8.2.3.1.4 Cell List Size

8.2.3.1.5 Maximum number of cells to be monitored

8.2.4 PLMN Selection and Re-Selection Scenario

8.2.5 Location Registration Scenario

8.3 RRC Connection mobility

8.3.1 Handover

- 8.3.1.1 Introduction
- 8.3.1.2 Handover 3G to 3G
 - 8.3.1.2.1 FDD Soft/Softer Handover
 - 8.3.1.2.1.1 Maximum number of cells to be reported
 - 8.3.1.2.1.2 Measurement reporting delay
 - 8.3.1.2.1.3 Test parameters
 - 8.3.1.2.1.3.1 Correct reporting of neighbours and timing measurement accuracy in AWGN propagation condition
 - 8.3.1.2.1.3.2 Correct reporting of neighbours in Fading propagation condition
 - 8.3.1.2.1.3.3 CPICH_Ec/Io measurement accuracy and incorrect reporting of neighbours in AWGN propagation condition
 - 8.3.1.2.1.4 Active set dimension
 - 8.3.1.2.1.5 Active set update delay
 - 8.3.1.2.2 FDD Hard Handover
 - 8.3.1.2.2.1 Requirements
 - 8.3.1.2.2.1.1 Maximum number of cells/frequencies to be monitored on other frequencies
 - 8.3.1.2.2.1.2 Measurement reporting delay
 - 8.3.1.2.2.1.2.1 System Level Requirement on Measurement Reporting Delay
 - 8.3.1.2.2.1.3 Hard Handover Delay
 - 8.3.1.2.3 FDD/TDD Handover
 - 8.3.1.2.3.1 Requirements
 - 8.3.1.2.3.2 RF Parameters
- 8.3.1.3 Handover 3G to 2G
 - 8.3.1.3.1 Handover to GSM
 - 8.3.1.3.1.1 Requirements
 - 8.3.1.3.1.2 RF Parameters
- 8.3.2 Radio Link Management

8.3.2.1 Link adaptation

8.3.2.1.1 Definition of the function

8.3.2.1.2 Link adaptation delay minimum requirement

8.3.2.1.3 Link adaptation maximum delay requirement

8.3.3 Cell Update

8.3.4 URA Update

8.4 RRC Connection Control

8.4.1 Requirements for RRC Re-establishment

8.4.1.1 RRC Re-establishment delay

8.4.1.2 Test Parameters

8.4.1.2.1 Test 1 - Target Cell known by UE

8.4.1.2.2 Test 2 - Target cell not known by UE

8.4.1.2.3 Performance Requirements

8.4.2 Radio Access Bearer Control

8.5 Radio Link Surveillance

8.6 Timing characteristics

8.6.1 Synchronization performance

8.6.1.1 Search of other Cells

8.6.1.1.1 Definition and applicability

Search for other cells is used to check whether the UE correctly searches and measures other BS(s) during the specified operation.

<Editor's Note: The applicability for this test whether it is mandatory or not should be clarified.>

8.6.1.1.2 Conformance requirements

[TBD]

Table 8.6.1.1.1: Test Parameters for the Search of other Cells

Parameter	Channel 1		Channel 2		Unit
	Time 1	Time 2	Time 1	Time 2	
$PCCPCH \frac{E_c}{I_{or}}$					dB
\hat{I}_{or}/I_{oc}					dB
I_{oc}	-60				dBm / 3,84 MHz
$PCCPCH \frac{E_c}{I_o}$					dB

The reference for this requirement is [2] TS 25.133 subclause 9.1.1.1.

8.6.1.1.3 Test purpose

[TBD]

8.6.1.1.4 Method of test

The measuring configuration is shown in Figure A.9.

8.6.1.1.4.1 Initial conditions

[TBD]

8.6.1.1.4.2 Procedures

1. Setup the equipment as shown in Figure A.11 (without fading channel blocks).
2. Set the test parameters as specified in Table 8.6.1.1.1.
3. Turn UE on.
4. TBD

8.6.1.1.5 Test requirements

[TBD]

8.6.2 UE Transmit Timing

8.6.2.1 Initial transmission timing, Maximum timing adjustment size and Maximum timing adjustment rate

8.6.2.1.1 Definition and applicability

The UE shall have capability to follow the frame timing change of the connected Node B. UE initial transmit timing accuracy, maximum amount of timing change in one adjustment, and maximum adjustment rate are defined in the following requirements.

<Editor's Note: The applicability for this test whether it is mandatory or not should be clarified.>

8.6.2.1.2 Conformance requirements

For parameters specified in Table 8.6.2.1.1, UE initial transmission timing error shall be less than or equal to $\pm 1,5$ Chip. The reference point for the UE initial transmit timing control requirement shall be the first significant path of the corresponding downlink DPCCH/DPDCH frame.

The UE shall be capable of changing the transmission timing according the received downlink DPCCH/DPDCH frame. The maximum amount of the timing change in one adjustment shall be 1/4 Chip.

The maximum adjustment rate shall be 1/4 chip per 280 ms. In particular, within any given 280 ms period, the UE transmit timing shall not change in excess of $\pm 1/4$ chip from the timing at the beginning of this 280 ms period.

Table 8.6.2.1.1: Test parameters for Transmission timing requirement.

Parameter	Cell 1 and 2 level	Unit
DPCH_Ec/ Ior	-17	dB
I _{or} , Cell 1	-96	dBm / 3,84 MHz
I _{or} , Cell 2	-97	dBm / 3,84 MHz
Information data rate	12,2	kbps
TFCI	On	-
Propagation condition	AWGN	

- a) Cell 2 starts transmission 5 seconds after call has been initiated. UE shall maintain it's original timing properties.
- b) Cell 1 stop transmission 5 seconds after cell 2 has started transmission. UE shall adjust transmission timing with a maximum change of 1/4 chip per adjustment, and maximum timing adjustment rate of 1/4 chip per 280 ms.

The reference for this requirement is [2] TS 25.133 subclause 9.2.1.1.

8.6.2.1.3 Test purpose

[TBD]

8.6.2.1.4 Method of test

8.6.2.1.4.1 Initial conditions

[TBD]

8.6.2.1.4.2 Procedures

[TBD]

8.6.2.1.5 Test requirements

[TBD]

8.6.3 Reception Timing

8.6.3.1 Definition and applicability

The reception timing of the UE is determined during the specified operation.

<Editor's Note: The applicability for this test whether it is mandatory or not should be clarified.>

8.6.3.2 Conformance requirements

[TBD]

The reference for this requirement is [2] TS 25.133 subclause 9.3.1.

8.6.3.3 Test purpose

[TBD]

8.6.3.4 Method of test

The measuring configuration is shown in Figure A.9.

8.6.3.4.1 Initial conditions

[TBD]

8.6.3.4.2 Procedures

[TBD]

8.6.3.5 Test requirements

[TBD]

8.6.4 Signalling requirements

8.6.4.1 Signalling response delay

8.6.4.2 Test Parameters

8.6.4.3 Performance requirements

8.6.4.4 Signalling processing

8.6.4.5 Test parameters

8.6.4.6 Performance requirements

8.7 Measurements Performance Requirements

8.7.1 CPICH RSCP

8.7.2 RSCP

8.7.3 SIR

8.7.4 UTRA carrier RSSI

8.7.5 GSM carrier RSSI

8.7.6 CPICH E_c/N_0

8.7.7 Transport channel BLER

8.7.8 Physical channel BER

8.7.9 UE transmitted power

8.7.10 CFN-SFN observed time difference

8.7.11 SFN-SFN observed time difference

8.7.12 UE Rx-Tx time difference

8.7.13 Observed time difference to GSM cell

Annex A (informative): Connection Diagrams

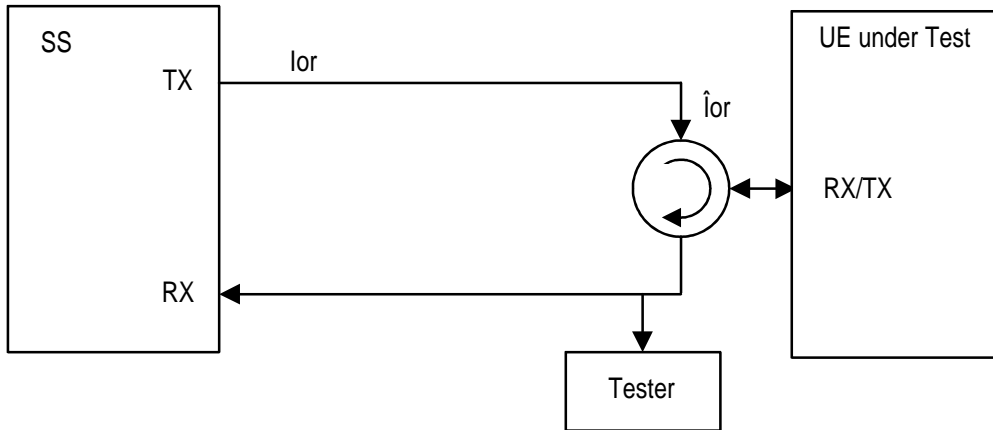

Figure A.1: Connection for Basic TX Test

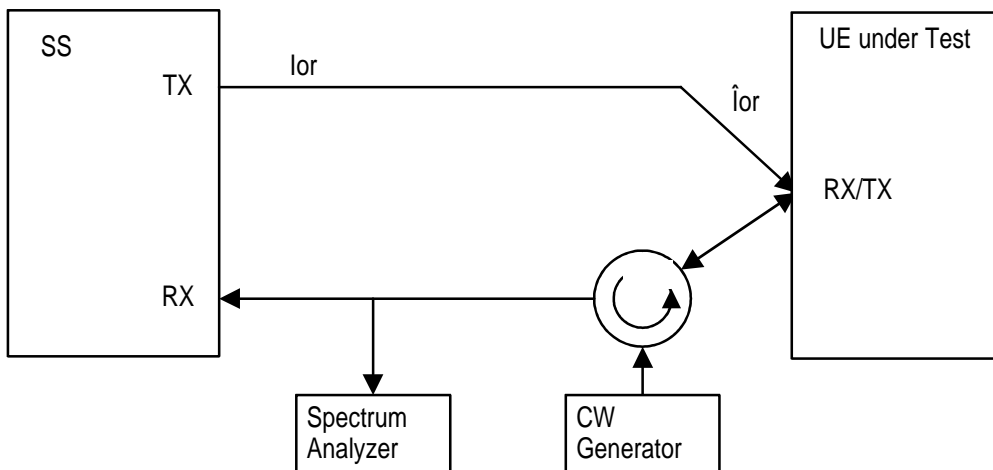

Figure A.2: Connection for TX Intermodulation Test

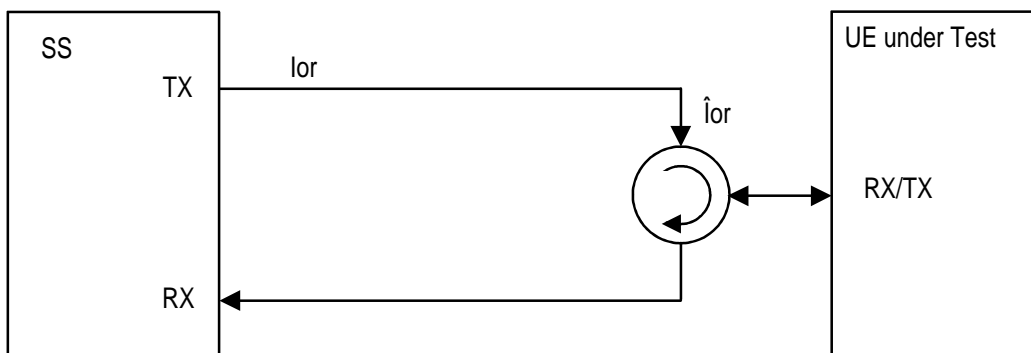

Figure A.3: Connection for Basic RX Test

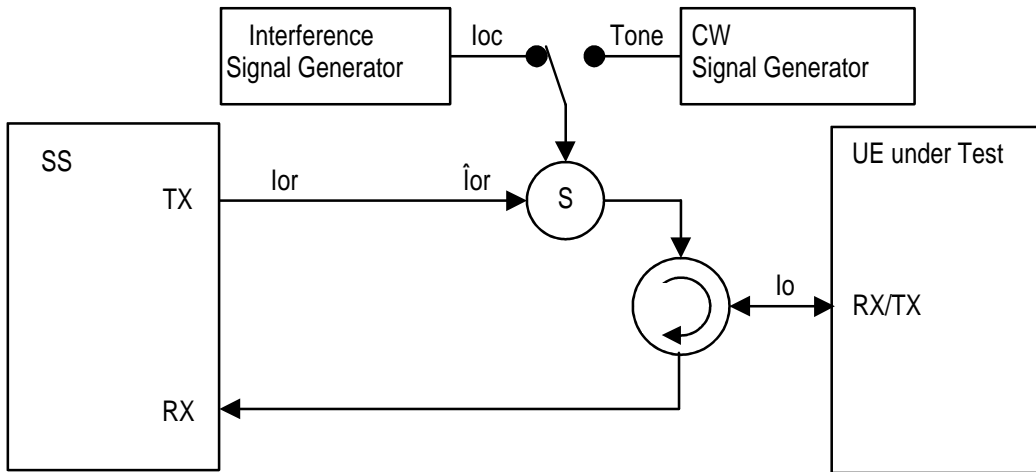

Figure A.5: Connection for RX Test with Interference or additional CW

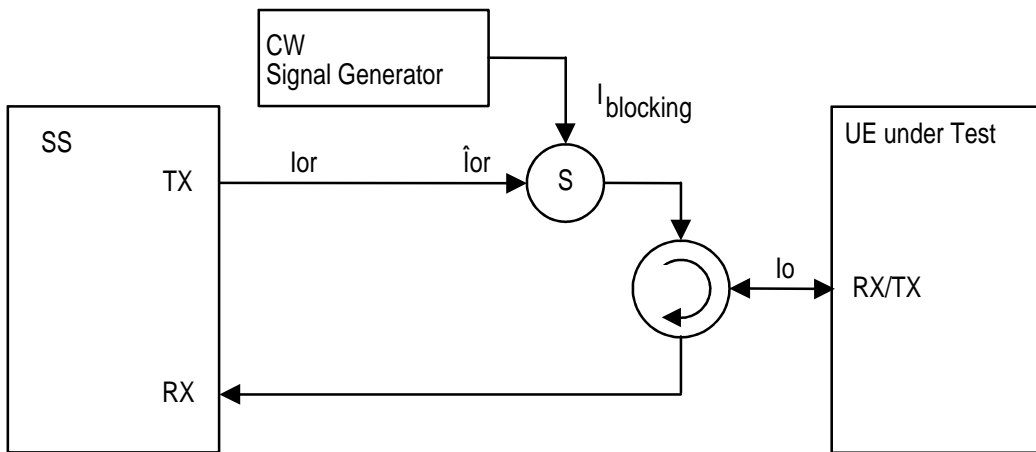

Figure A.6: Connection for RX Test with additional CW

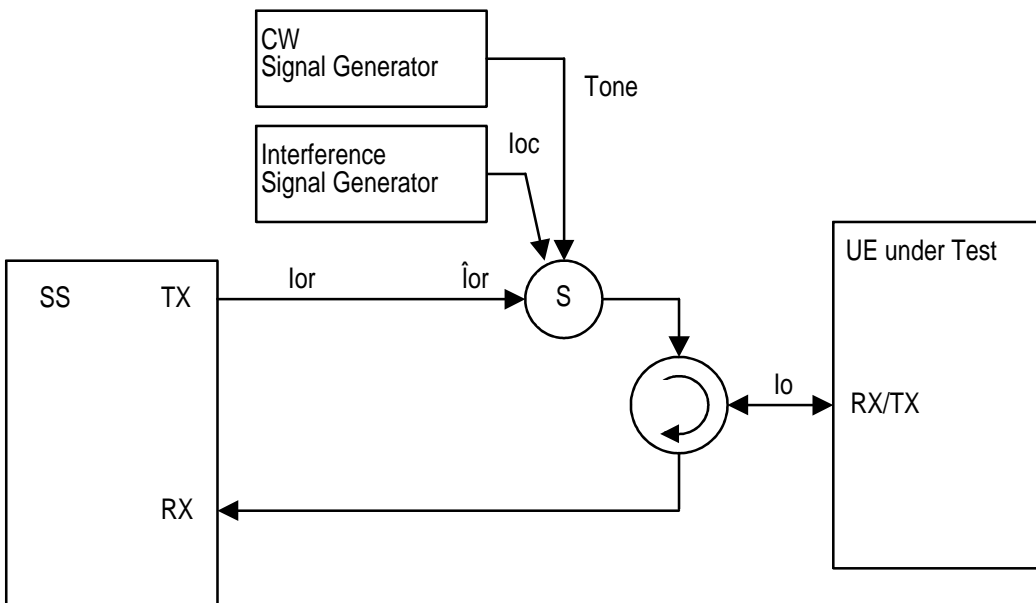

Figure A.7: Connection for RX Test with both Interference and additional CW

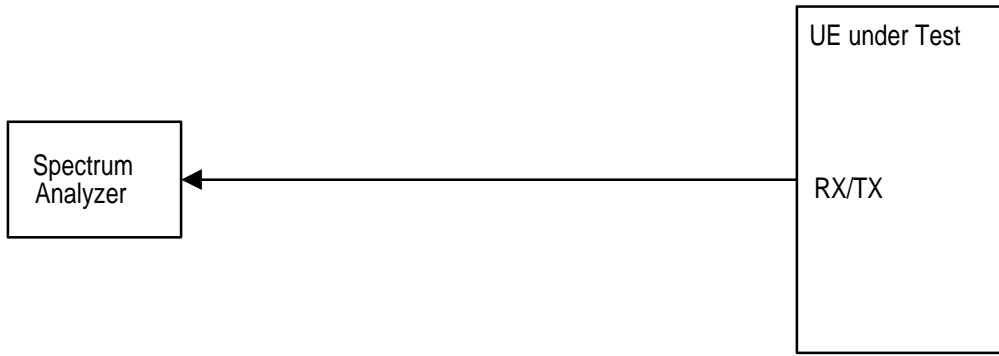

Figure A.8: Connection for Spurious Emission Test

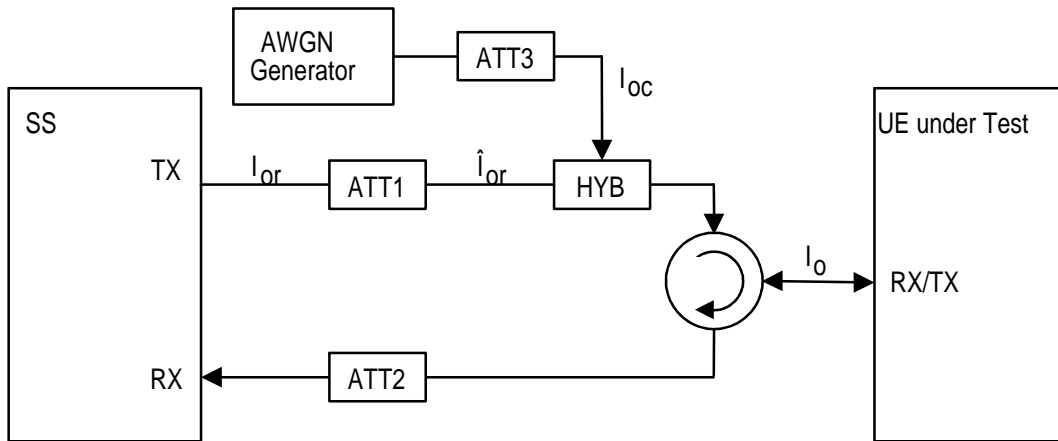

Figure A.9: Connection for Static Propagation Test

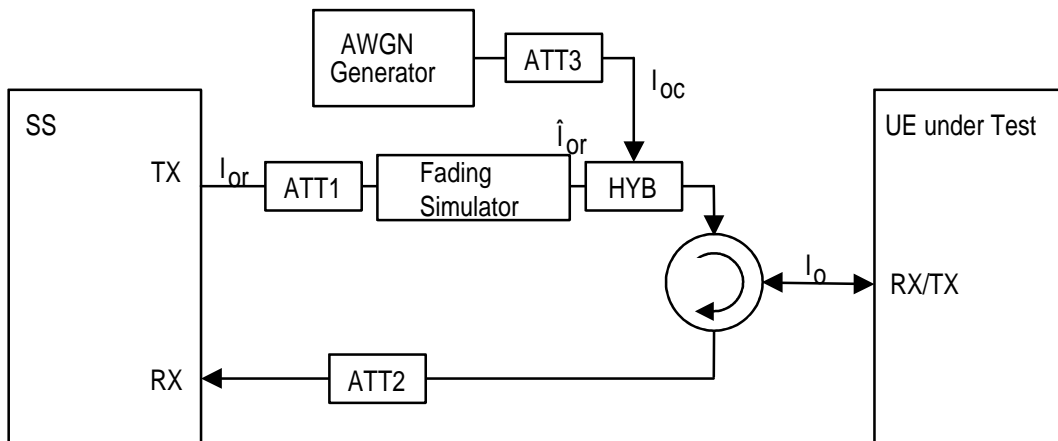

Figure A.10: Connection for Multi-path Fading Propagation Test

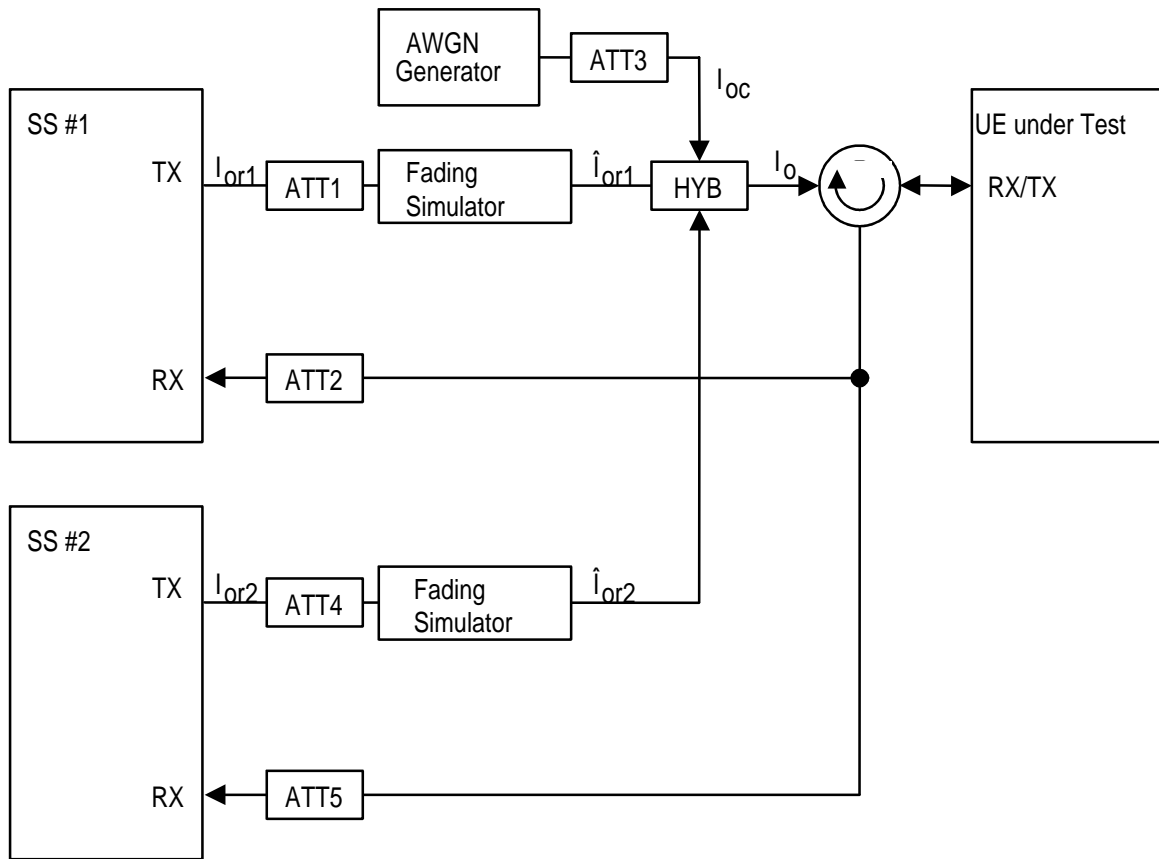

Figure A.11: Connection for Inter-Cell Soft Handover Test

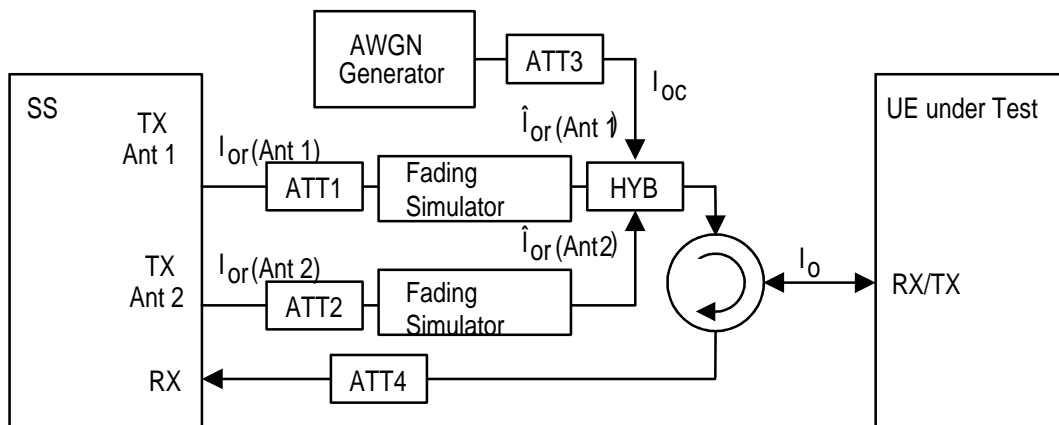

Figure A.12: Connection for Demodulation of DCH in open and closed loop transmit diversity modes

Annex B (normative): Global In-Channel TX-Test

B.1 General

The global in-channel Tx test enables the measurement of all relevant parameters that describe the in-channel quality of the output signal of the Tx under test in a single measurement process.

The objective of this Annex is to list the results that should be available from the Global In-Channel TX-Test. To aid understanding, an example algorithmic description of the measurement process is provided. It is not intended that this particular method is required. It is however required that any algorithm that is used for In-Channel TX tests should deliver the required results with the required accuracy.

B.2 Definition of the process

B.2.1 Basic principle

The process is based on the comparison of the actual **output signal of the Tx under test**, received by an ideal receiver, with a **reference signal**, that is generated by the measuring equipment and represents an ideal error free received signal. All signals are represented as equivalent (generally complex) baseband signals.

B.2.2 Output signal of the Tx under test

The output signal of the Tx under test is recorded through a matched filter (RRC 0.22, correct in shape and in position on the frequency axis) at one sample per chip.

Depending on the parameter to be evaluated, it is appropriate to represent the recorded signal in one of the following two different forms:

Form1 (representing the physical error signal in the entire measurement interval)

One vector **Z**, containing $N = n \times m$ complex samples;
with
n: number of symbols in the measurement interval;
m: number of chips per symbol.

Form 2 (derived from form 1 by descrambling and separating the samples into symbol intervals): n time-sequential vectors **z** with m complex samples, where each vector comprises a symbol interval

B.2.3 Reference signal

The reference signal is constructed by the measuring equipment according to the relevant Tx specifications, filtered by a matched filter and sampled at the Inter-Symbol-Interference-free instants.

Depending of the parameter to be evaluated, it is appropriate to represent the reference set of samples in one of the following three different forms:

Form 1 (representing the physical signal in the entire measurement interval):

One vector \mathbf{R} , containing $N = n \times m$ complex samples;
with
n: number of symbols in the measurement interval;
m: number of chips per symbol.

Form 2 (derived from form 1 before scrambling and by separating the samples into symbol intervals)
n time-sequential vectors \mathbf{r} with m complex samples, where each vector comprises a symbol interval.
(Note: Clarification is needed in case of a multi-code with multi-rate signal)

Form 3 (derived from form 2 by separating the samples into code signals)

n sequential expressions $\sum_{i=1}^k \mathbf{r}\mathbf{c}_i$,

with
k: number of codes;
a single summand $\mathbf{r}\mathbf{c}_i$ representing the vector of one code i, containing m complex samples of the symbol interval

B.2.4 Provisions in case of multi code signals

In case of multi code signals, the code multiplex shall contain only orthogonal codes. (Otherwise non-orthogonal codes must be eliminated (e.g. by time-windowing the measurement interval or switch off)).

B.2.5 Classification of measurement results

The measurement results achieved by the global in-channel Tx test can be classified into two types:

Results of type 1, where the error-free parameter has a non-zero magnitude (These are the absolute parameters that represent the modified reference signal). These parameters are:

RF Frequency
(Chip Frequency)
Power
Code Domain Power (in case of multi code)
Timing (only for UE)

Results of type 2, where the error-free parameter has value zero (These are the parameters that represent the error values of the measured signal, whose ideal magnitude is zero). These parameters are:

Error Vector Magnitude
Peak Code Domain Error

B.2.6 Process definition to achieve results of type 1

The reference signal is varied with respect to the parameters mentioned in subclause B.2.5 under "results of type 1" in order to achieve best fit with the recorded signal under test (output signal of the Tx under test, filtered and sampled according to subclause B.2.2). Best fit is achieved when the RMS difference value between the signal under test and the varied reference signal is an absolute minimum. The varied reference signal in this best fit case will be called \mathbf{R}' .

The varied parameters, leading to \mathbf{R}' represent directly the wanted results of type 1. These measurement parameters are expressed as deviation from the reference value with units same as the reference value.

In case of multi code, the type-1-parameters (frequency, (chip frequency) and timing) are varied commonly for all codes such that the process returns one frequency-error, (one chip-frequency error), one timing error.

(These parameters are not varied on the individual code signals such that the process returns k frequency errors.... (k: number of codes)).

The only type-1-parameters varied individually are the code powers such that the process returns k code powers (k: number of codes)

B.2.7 Process definition to achieve results of type 2

The difference between the signal under test (**Z**; see subclause B.2.2) and the reference signal after the minimum process (**R'**; see subclause B.2.6) is the error vector **E** versus time:

$$\mathbf{E} = \mathbf{Z} - \mathbf{R}'.$$

Depending on the parameter to be evaluated, it is appropriate to represent **E** in one of the following two different forms:

Form 1 (representing the physical error signal in the entire measurement interval)

One vector **E**, containing $N = n \times m$ complex samples;
with
n: number of symbols in the measurement interval;
m: number of chips per symbol.

Form 2 (derived from form 1 by separating the samples into symbol intervals)

n time-sequential vectors **e** with m complex samples comprising one symbol interval

E gives results of type 2 applying the two algorithms defined in subclauses B.2.7.1 and B.2.7.2.

B.2.7.1 Error Vector Magnitude

The Error Vector Magnitude EVM is calculated according to the following steps:

- (1) Take the error vector **E** defined in subclause B.2.7 (form 1) and calculate the RMS value of **E** chip-wise over the entire measurement interval; the result will be called RMS(**E**).
- (2) Take the reference vector **R** defined in subclause B.2.3 (form 1) and calculate the RMS value of **R** chip-wise over the entire measurement interval; the result will be called RMS(**R**).
- (3) Calculate EVM according to

$$\text{EVM} = \frac{\text{RMS}(\mathbf{E})}{\text{RMS}(\mathbf{R})} \times 100\%$$

(here, EVM is relative and expressed in %)

B.2.7.2 Peak Code Domain Error

The Peak Code Domain Error is calculated according to the following steps:

- (1) Take the error vectors **e** defined in subclause B.2.7 (form 2) and the reference vectors **rc** defined in subclause B.2.3 (form 3) and calculate the inner product of **e** and **rc** chip-wise over the symbol duration for all symbols of the measurement interval and for all codes in the code space.

This gives a matrix of format $k \times n$, each value representing an error voltage connected with a specific symbol and a specific code, which can be exploited in a large variety of ways.

k: number of codes used in the current test case

n: number of symbols in the measurement interval

- (2) Calculate k RMS values, each RMS value unifying n symbols within one code.

(This values can be called "absolute Code-EVMs" [Volt]).

(3) Find the peak value among the k "absolute Code-EVMs".

(This value can be called "absolute Peak-Code-EVM" [Volt]).

(4) Calculate the following term:

$$10 \log \frac{(\text{absolute Peak - Code - EVM})^2}{(\text{RMS}(\mathbf{R}))^2} \text{ dB} .$$

This term is called Peak Code Domain Error (a relative value in dB).

(5) If the values RMS(\mathbf{r}) are not constant during the measurement interval, Peak Code Domain Error should be expressed absolutely instead by the term:

$$\frac{(\text{absolute Peak - Code - EVM})^2}{50 \text{ Ohm}}$$

This term is called Absolute Peak Code Domain Error [Watt or dBm]

B.3 Application

This process is applicable to the following paragraphs:

- 5.3 Frequency Stability
- 5.4 Output Power Dynamics in the Uplink
 - 5.4.1 Open Loop Power Control in the Uplink
 - 5.4.2 Inner Loop Power Control in the Uplink
 - 5.4.3 Minimum Output Power
- 5.5 Transmit ON/OFF Power
- 5.6 Change of TFC
 - 5.13 Transmit Modulation
 - 5.13.2 Modulation Accuracy
 - 5.13.3 Peak code Domain error
 - 5.13.x (Chip Frequency)

Annex C (normative): Measurement channels

C.1 General

The measurement channels in this annex are defined to derive the requirements in clauses 5, 6 and 7. The measurement channels represent example configuration of radio access bearers for different data rates.

The measurement channel for 12.2 kbps shall be supported by any UE both in up- and downlink. Support for other measurement channels is depending on the UE Radio Access capabilities.

C.2 UL reference measurement channel

C.2.1 UL reference measurement channel (12.2 kbps)

The parameters for the 12.2 kbps UL reference measurement channel are specified in Table C.2.1.1 and Table C.2.1.2. The channel coding for information is shown in Figure C.2.1

Table C.2.1.1: UL reference measurement channel physical parameters (12,2 kbps)

Parameter	Level	Unit
Information bit rate	12.2	kbps
DPDCH	60	kbps
DPCCH	15	kbps
DPCCH/DPDCH	-6	dB
TFCI	On	-
Repetition	23	%

Table C.2.1.2: UL reference measurement channel, transport channel parameters (12,2 kbps)

Parameters	DCCH	DTCH
Transport Channel Number	1 (TBD by RAN WG2)	2 (TBD by RAN WG2)
Transport Block Size	96	244
Transport Block Set Size	96	244
Transmission Time Interval	40 ms	20 ms
Type of Error Protection	Convolution Coding	Convolution Coding
Coding Rate	1/3	1/3
Static Rate Matching parameter	1,0	1,0
Size of CRC	16	16
Position of TrCH in radio frame	fixed	fixed

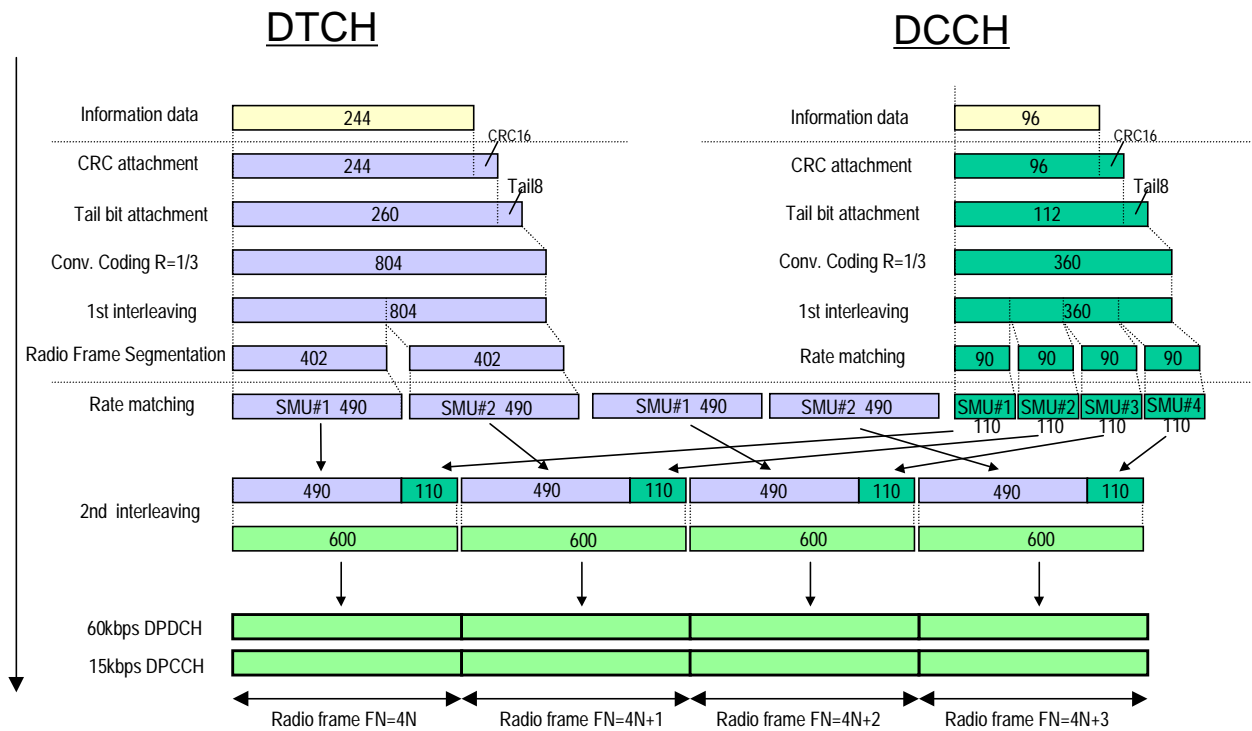

Figure C.2.1 (Informative): Channel coding of UL reference measurement channel (12,2 kbps)

C.2.2 UL reference measurement channel (64 kbps)

The parameters for the 64 kbps UL reference measurement channel are specified in Table C.2.2.1 and Table C.2.2.2. The channel coding for information is shown in Figure C.2.2. This measurement channel is not currently used in TS25.101 but can be used for future requirements.

Table C.2.2.1: UL reference measurement channel (64 kbps)

Parameter	Level	Unit
Information bit rate	64	kbps
DPDCH	240	kbps
DPCCH	15	kbps
DPCCH/DPDCH	-9	dB
TFCI	On	-
Repetition	18	%

Table C.2.2.2: UL reference measurement channel, transport channel parameters (64 kbps)

Parameter	DCCH	DTCH
Transport Channel Number	1 (TBD by RAN WG2)	2 (TBD by RAN WG2)
Transport Block Size	96	1280
Transport Block Set Size	96	1280
Transmission Time Interval	40 ms	20 ms
Type of Error Protection	Convolution Coding	Turbo Coding
Coding Rate	1/3	1/3
Static Rate Matching parameter	1,0	1,0
Size of CRC	16	16
Position of TrCH in radio frame	fixed	fixed

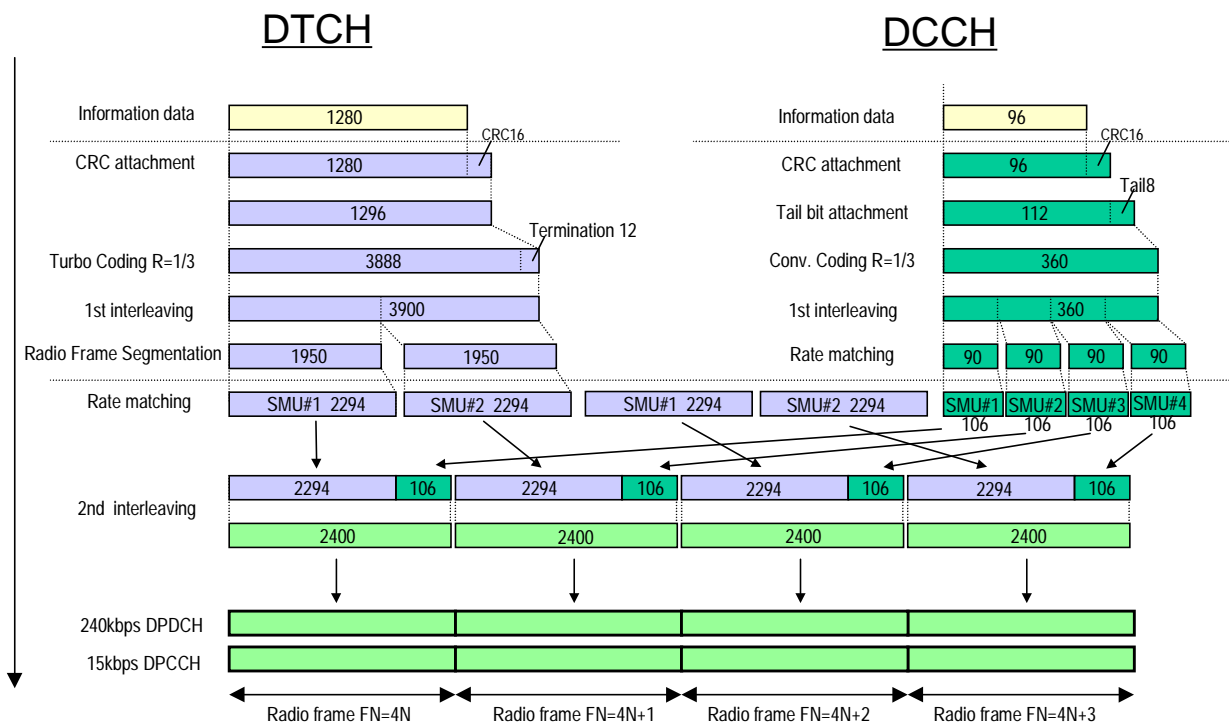

Figure C.2.2 (Informative): Channel coding of UL reference measurement channel (64 kbps)

C.2.3 UL reference measurement channel (144 kbps)

The parameters for the 144 kbps UL reference measurement channel are specified in Table C.2.3.1 and Table C.2.3.2. The channel coding for information is shown in Figure C.2.3. This measurement channel is not currently used in TS25.101 but can be used for future requirements.

Table C.2.3.1: UL reference measurement channel (144 kbps)

Parameter	Level	Unit
Information bit rate	144	kbps
DPDCH	480	kbps
DPCCH	15	kbps
DPCCH/DPDCH	-12	dB
TFCI	On	-
Repetition	8	%

Table C.2.3.2: UL reference measurement channel, transport channel parameters (144 kbps)

Parameters	DCCH	DTCH
Transport Channel Number	1 (TBD by RAN WG2)	2 (TBD by RAN WG2)
Transport Block Size	96	2880
Transport Block Set Size	96	2880
Transmission Time Interval	40 ms	20 ms
Type of Error Protection	Convolution Coding	Turbo Coding
Coding Rate	1/3	1/3
Static Rate Matching parameter	1,0	1,0
Size of CRC	16	16
Position of TrCH in radio frame	fixed	fixed

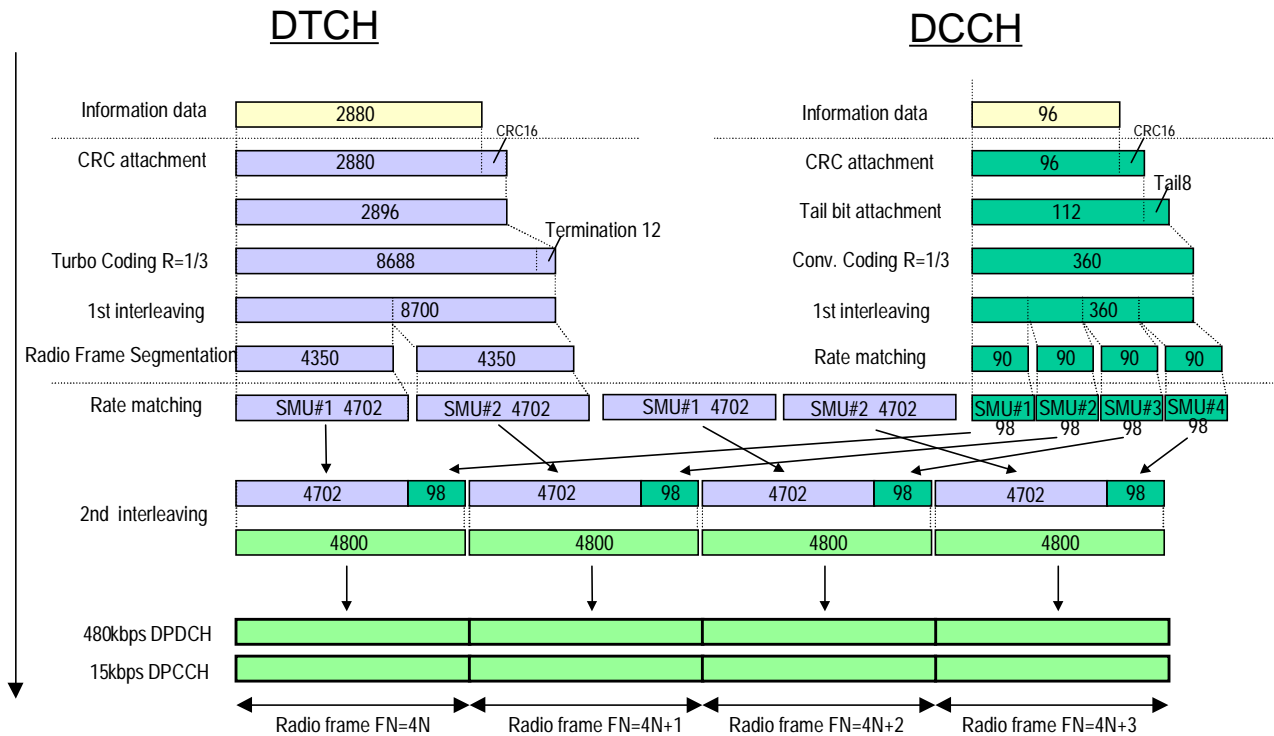

Figure C.2.3 (Informative): Channel coding of UL reference measurement channel (144 kbps)

C.2.4 UL reference measurement channel (384 kbps)

The parameters for the 384 kbps UL reference measurement channel are specified in Table C.2.4.1 and Table C.2.4.2. The channel coding for information is shown in Figure C.2.4. This measurement channel is not currently used in TS25.101 but can be used for future requirements.

Table C.2.4.1: UL reference measurement channel (384 kbps)

Parameter	Level	Unit
Information bit rate	384	kbps
DPDCH	960	kbps
DPCCH	15	kbps
DPCCH/DPDCH	-12	dB
TFCI	On	-
Puncturing	18	%

Table C.2.4.2: UL reference measurement channel, transport channel parameters (384 kbps)

Parameter	DCCH	DTCH
Transport Channel Number	1 (TBD by RAN WG2)	2 (TBD by RAN WG2)
Transport Block Size	96	3840
Transport Block Set Size	96	7680
Transmission Time Interval	40 ms	20 ms
Type of Error Protection	Convolution Coding	Turbo Coding
Coding Rate	1/3	1/3
Static Rate Matching parameter	1,0	1,0
Size of CRC	16	16
Position of TrCH in radio frame	fixed	fixed

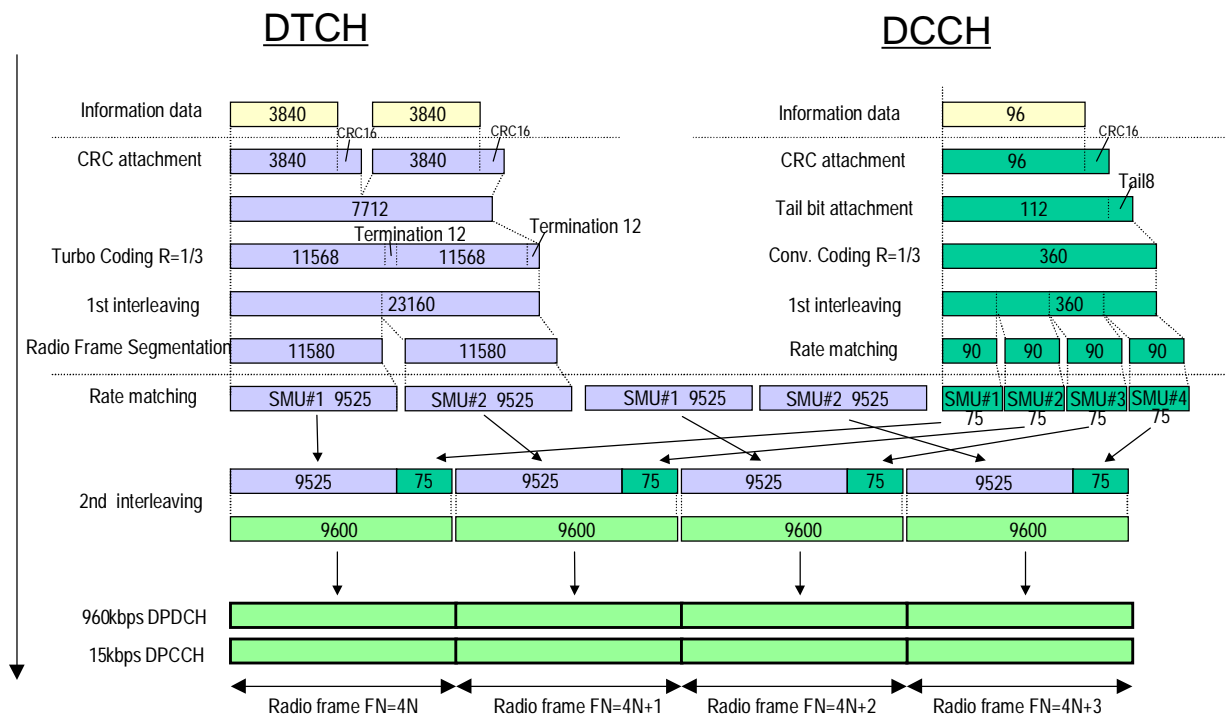

Figure C.2.4 (Informative): Channel coding of UL reference measurement channel (384 kbps)

C.3 DL reference measurement channel

C.3.1 DL reference measurement channel (12,2 kbps)

The parameters for the 12.2 kbps DL reference measurement channel are specified in Table C.3.1 and Table C.3.2. The channel coding is detailed in Figure C.3.1.

Table C.3.1: DL reference measurement channel (12,2 kbps)

Parameter	Level	Unit
Information bit rate	12.2	kbps
DPCCH	30	ksps
TFCI	On	
Puncturing	14,5	%

Table C.3.2: DL reference measurement channel, transport channel parameters (12,2 kbps)

Parameter	DCCH	DTCH
Transport Channel Number	1 (TBD by RAN WG2)	2 (TBD by RAN WG2)
Transport Block Size	96	244
Transport Block Set Size	96	244
Transmission Time Interval	40 ms	20 ms
Type of Error Protection	Convolution Coding	Convolution Coding
Coding Rate	1/3	1/3
Static Rate Matching parameter	1,0	1,0
Size of CRC	16	16
Position of TrCH in radio frame	fixed	fixed

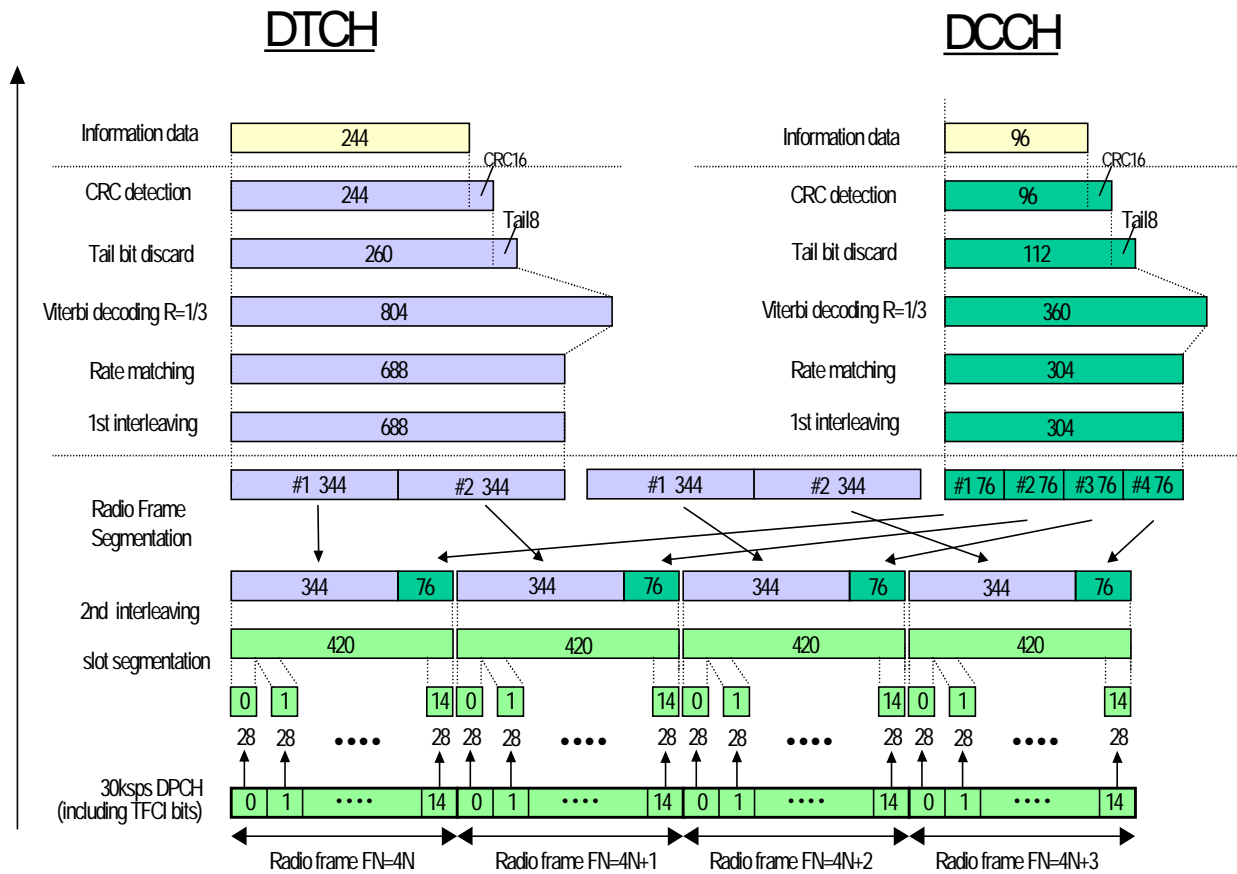

Figure C.3.1 (Informative): Channel coding of DL reference measurement channel (12,2 kbps)

C.3.2 DL reference measurement channel (64 kbps)

The parameters for the DL reference measurement channel for 64 kbps are specified in Table C.3.3 and Table C.3.4. The channel coding is detailed in Figure C.3.2.

Table C.3.3: DL reference measurement channel (64 kbps)

Parameter	Level	Unit
Information bit rate	64	kbps
DPCH	120	ksps
TFCI	On	-
Repetition	2,9	%

Table C.3.4: DL reference measurement channel, transport channel parameters (64 kbps)

Parameter	DCCH	DTCH
Transport Channel Number	1 (TBD by RAN WG2)	2 (TBD by RAN WG2)
Transport Block Size	96	1280
Transport Block Set Size	96	1280
Transmission Time Interval	40 ms	20 ms
Type of Error Protection	Convolution Coding	Turbo Coding
Coding Rate	1/3	1/3
Static Rate Matching parameter	1,0	1,0
Size of CRC	16	16
Position of TrCH in radio frame	fixed	fixed

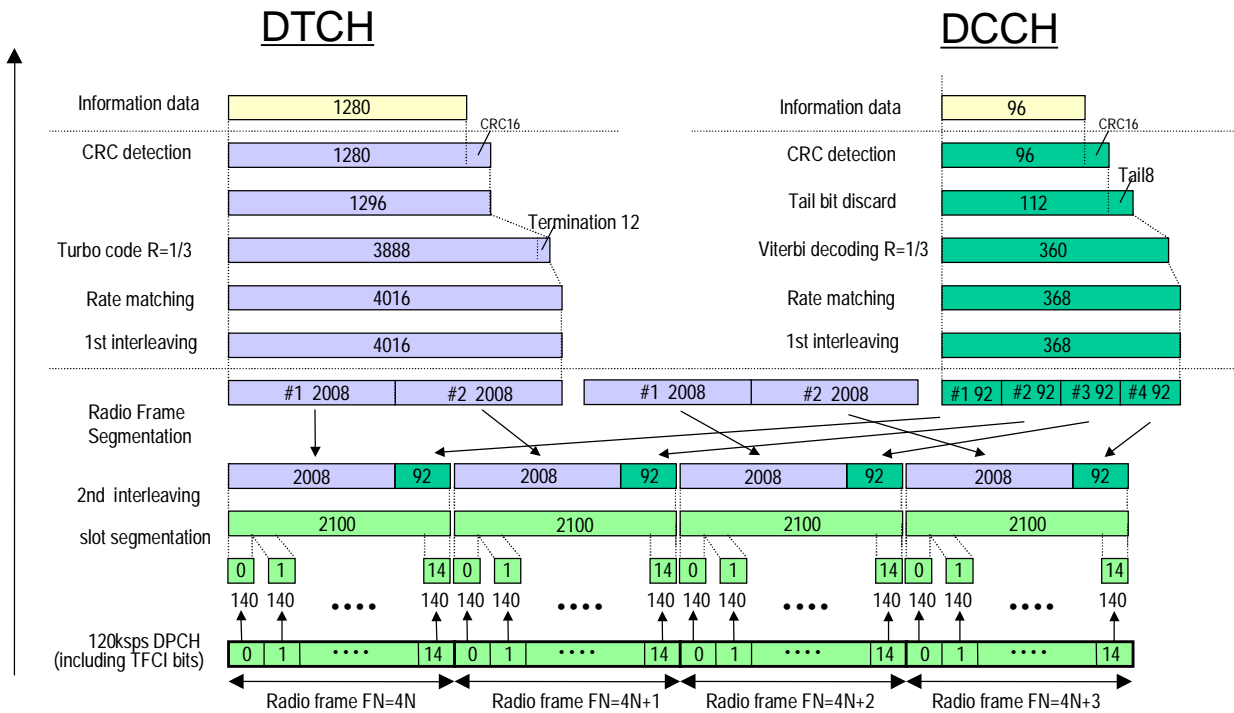

Figure C.3.2 (Informative): Channel coding of DL reference measurement channel (64 kbps)

C.3.3 DL reference measurement channel (144 kbps)

The parameters for the DL reference measurement channel for 144 kbps are specified in Table C.3.5 and Table C.3.6. The channel coding is detailed in Figure C.3.3.

Table C.3.5: DL reference measurement channel (144kbps)

Parameter	Level	Unit
Information bit rate	144	kbps
DPCH	240	ksps
TFCI	On	
Puncturing	2,7	%

Table C.3.6: DL reference measurement channel, transport channel parameters (144 kbps)

Parameter	DCCH	DTCH
Transport Channel Number	1 (TBD by RAN WG2)	2 (TBD by RAN WG2)
Transport Block Size	96	2880
Transport Block Set Size	96	2880
Transmission Time Interval	40 ms	20 ms
Type of Error Protection	Convolution Coding	Turbo Coding
Coding Rate	1/3	1/3
Static Rate Matching parameter	1,0	1,0
Size of CRC	16	16
Position of TrCH in radio frame	fixed	fixed

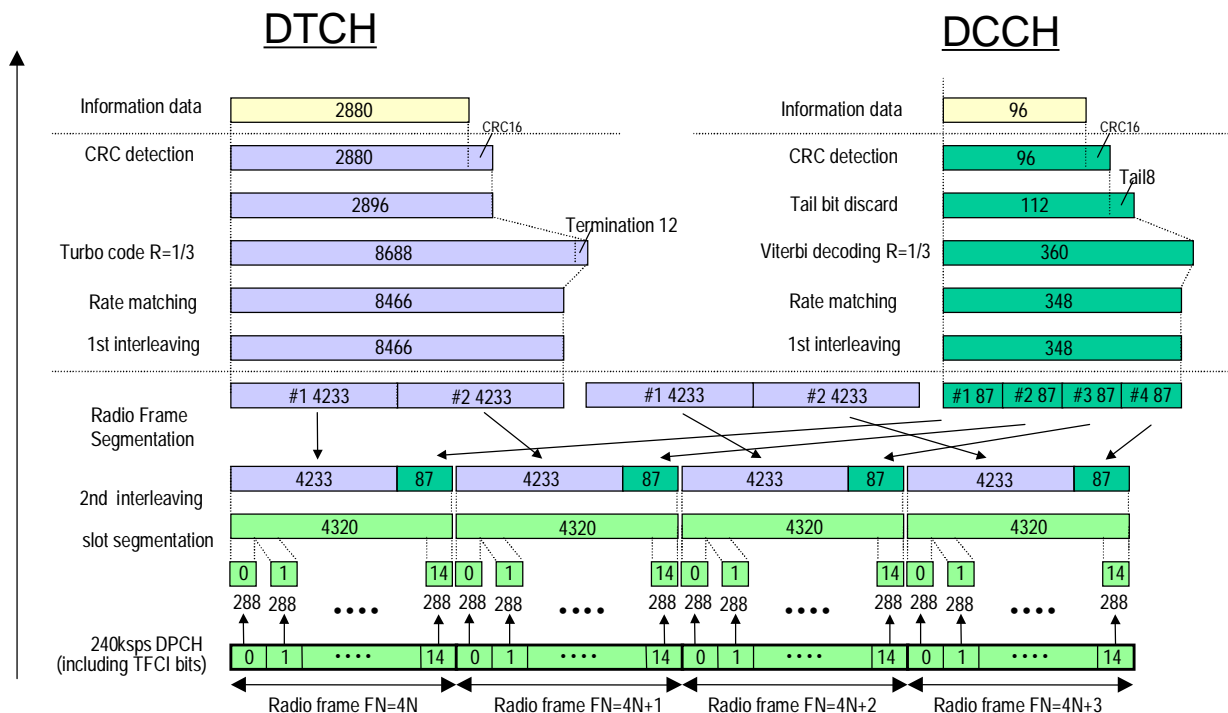

Figure C.3.3 (Informative): Channel coding of DL reference measurement channel (144 kbps)

C.3.4 DL reference measurement channel (384 kbps)

The parameters for the DL reference measurement channel for 384 kbps are specified in Table C.3.7 and Table C.3.8. The channel coding is detailed in Figure C.3.4.

Table C.3.7: DL reference measurement channel (384kbps)

Parameter	Level	Unit
Information bit rate	384	kbps
DPCH	480	ksps
TFCI	On	
Puncturing	22	%

Table C.3.8: DL reference measurement channel, transport channel parameters (384 kbps)

Parameter	DCCH	DTCH
Transport Channel Number	1 (TBD by RAN WG2)	2 (TBD by RAN WG2)
Transport Block Size	96	3840
Transport Block Set Size	96	7680
Transmission Time Interval	40 ms	20 ms
Type of Error Protection	Convolution Coding	Turbo Coding
Coding Rate	1/3	1/3
Static Rate Matching parameter	1,0	1,0
Size of CRC	16	16
Position of TrCH in radio frame	fixed	fixed

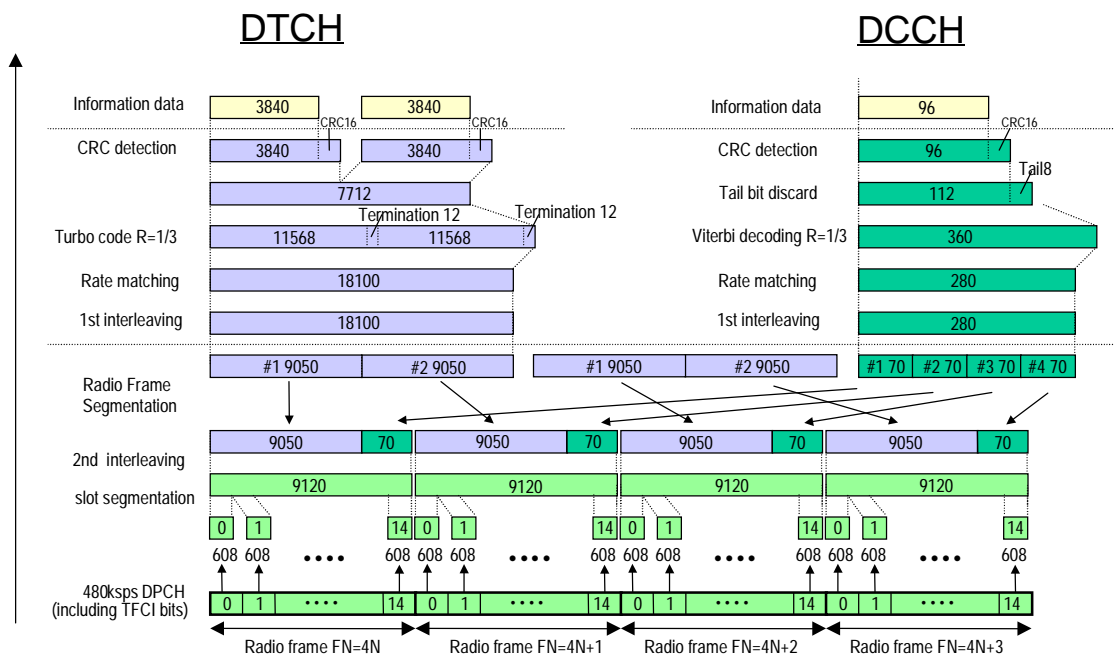

Figure C.3.4 (Informative): Channel coding of DL reference measurement channel (384 kbps)

C.4 DL reference compressed mode parameters

The following parameters characterise the transmission gap :

- TGL: 7
- SFN: FFS
- SN: FFS

The following parameters characterise the compressed mode pattern :

- TGP: FFS
- TGL: 7
- TGD: FFS
- PD: FFS
- SFN: FFS
- PCM: FFS

Transmission time reduction method FFS.

Annex D (normative): Propagation Conditions

D.1 General

D.2 Propagation Conditions

D.2.1 Static propagation condition

The propagation for the static performance measurement is an Additive White Gaussian Noise (AWGN) environment. No fading and multi-paths exist for this propagation model.

D.2.2 Multi-path fading propagation conditions

Table D.2.2.1 shows propagation conditions that are used for the performance measurements in multi-path fading environment. All taps have classical Doppler spectrum.

Table D.2.2.1: Propagation condition for multi-path fading environments

Case 1, speed 3km/h		Case 2, speed 3 km/h		Case 3, 120 km/h		Case 4, 15 km/h	
Relative Delay [ns]	Average Power [dB]	Relative Delay [ns]	Average Power [dB]	Relative Delay [ns]	Average Power [dB]	Relative Delay [ns]	Average Power [dB]
0	0	0	0	0	0	0	0
976	-10	976	0	260	-3	976	0
		[20000]	0	521	-6		
				781	-9		

D.2.3 Moving propagation conditions

The dynamic propagation conditions for the test of the baseband performance are non fading channel models with two taps. The moving propagation condition has two taps, one static, Path0, and one moving, Path1. The time difference between the two paths is according Equation D.2.3.1.

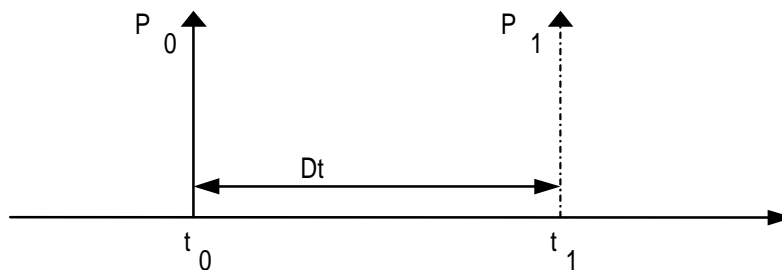

Figure D.2.3.1: The moving propagation conditions

$$\Delta\tau = \left(1 + \frac{A}{2} (1 + \sin(\Delta\omega \cdot t)) \right) \tag{Equation D.2.3.1}$$

The parameters in the equation are shown in.

A	5 μs
$\Delta\omega$	$40 \cdot 10^{-3} \text{ s}^{-1}$

D.2.4 Birth-Death propagation conditions

The dynamic propagation conditions for the test of the baseband performance is a non fading propagation channel with two taps. The moving propagation condition has two taps, Path1 and Path2 while alternate between 'birth' and 'death'. The positions the paths appear are randomly selected with an equal probability rate and are shown in Figure D.2.4.1.

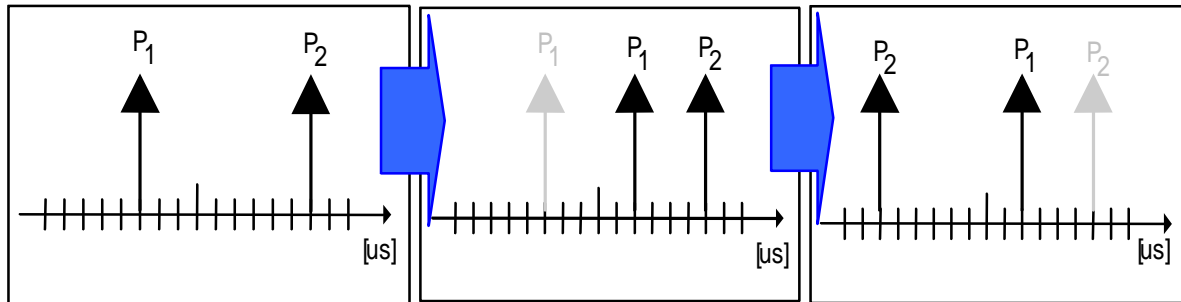

Figure D.2.4.1: Birth death propagation sequence

NOTE:

1. Two paths, Path1 and Path2 are randomly selected between $-5 \mu\text{s}$ and $+5 \mu\text{s}$.
2. After 191 ms, Path1 vanishes and reappears immediately at a new location randomly selected between $-5 \mu\text{s}$ and $+5 \mu\text{s}$ but excludes the point Path2.
3. After additional 191 ms, Path2 vanishes and reappears immediately at a new location randomly selected between $-5 \mu\text{s}$ and $+5 \mu\text{s}$ but excludes the point Path1.
4. The sequence in 2) and 3) is repeated.

Annex E (normative): Downlink Physical Channels

E.1 General

This Normative annex specifies the downlink physical channels that are needed for setting a connection and channels that are needed during a connection.

E.2 Connection Set-up

Table E2 describes the downlink Physical Channels that are required for connection set up.

Table E.2: Downlink Physical Channels required for connection set-up

Physical Channel
CPICH
PCCPCH
SCH
SCCPCH
PICH
AICH
DPCH

E.3 During connection

The following clauses describe the downlink Physical Channels that are transmitted during a connection i.e., when measurements are done. For these measurements the offset between DPCH and SCH shall be zero chips at base station meaning that SCH is overlapping with the first symbols in DPCH in the beginning of DPCH slot structure.

E.3.1 Measurement of Tx Characteristics

Table E.3.1 is applicable for measurements on the Transmitter Characteristics (clause 5) with the exception of subclauses 5.3 (Frequency Stability), 5.4.1 (Open Loop Power Control in the Uplink), and 5.5.2 (Transmit ON/OFF Time mask). For these cases, the power levels of \hat{I}_{or} and DPCH are defined individually.

NOTE: Applicability to subclause 5.7 (Power setting in uplink compressed mode) is FFS.

Table E.3.1: Downlink Physical Channels transmitted during a connection

Physical Channel	Power
\hat{I}_{or}	-93 dBm / 3.84MHz
CPICH	CPICH_Ec / DPCH_Ec = 7 dB
PCCPCH	PCCPCH_Ec / DPCH_Ec = 5 dB
SCH	SCH_Ec / DPCH_Ec = 5 dB
PICH	PICH_Ec / DPCH_Ec = 2 dB
DPCH	-103,3 dBm / 3,84MHz

E.3.2 Measurement of Rx Characteristics

Table E.3.2 is applicable for measurements on the Receiver Characteristics (clause 6) with the exception of subclause 6.3 (Maximum input level).

Table E.3.2: Downlink Physical Channels transmitted during a connection

Physical Channel	Power
CPICH	$CPICH_{Ec} / DPCH_{Ec} = 7$ dB
PCCPCH	$PCCPCH_{Ec} / DPCH_{Ec} = 5$ dB
SCH	$SCH_{Ec} / DPCH_{Ec} = 5$ dB
PICH	$PICH_{Ec} / DPCH_{Ec} = 2$ dB
DPCH	Test dependent power

E.3.3 Measurement of Performance requirements

Table E.3.3 is applicable for measurements on the Performance requirements (clause 7), including subclause 6.3 (Maximum input level), excluding subclauses 7.6.1 (Demodulation of DCH in open loop transmit diversity mode) and 7.6.2 (Demodulation of DCH in closed loop transmit diversity mode).

Table E.3.3: Downlink Physical Channels transmitted during a connection²

Physical Channel	Power	Note
CPICH	$CPICH_{Ec}/I_{or} = -10$ dB	
PCCPCH	$PCCPCH_{Ec}/I_{or} = -12$ dB	
SCH	$SCH_{Ec}/I_{or} = -12$ dB	This power shall be divided equally between Primary and Secondary Synchronous channels
PICH	$PICH_{Ec}/I_{or} = -15$ dB	
DPCH	Test dependent power	
OCNS	Necessary power so that total transmit power spectral density of BS (I_{or}) adds to one	

E.3.4 Connection with open-loop transmit diversity mode

Table E.3.4 is applicable for measurements for subclause 7.6.1 (Demodulation of DCH in open loop transmit diversity mode)

Table E.3.4: Downlink Physical Channels transmitted during a connection³

Physical Channel	Power	Note
CPICH (antenna 1)	$CPICH_{Ec1}/I_{or} = -13$ dB	1. Total $CPICH_{Ec}/I_{or} = -10$ dB
CPICH (antenna 2)	$CPICH_{Ec2}/I_{or} = -13$ dB	
PCCPCH (antenna 1)	$PCCPCH_{Ec1}/I_{or} = -15$ dB	1. STTD applied 2. Total $PCCPCH_{Ec}/I_{or} = -12$ dB
PCCPCH (antenna 2)	$PCCPCH_{Ec2}/I_{or} = -15$ dB	
SCH (antenna 1 / 2)	$SCH_{Ec}/I_{or} = -12$ dB	1. TSTD applied. 2. This power shall be divided equally between Primary and Secondary Synchronous channels
PICH (antenna 1)	$PICH_{Ec1}/I_{or} = -18$ dB	1. STTD applied 2. Total $PICH_{Ec}/I_{or} = -15$ dB
PICH (antenna 2)	$PICH_{Ec2}/I_{or} = -18$ dB	
DPCH	Test dependent power	1. STTD applied 2. Total power from both antennas
OCNS	Necessary power so that total transmit power spectral density of BS (I_{or}) adds to one	1. This power shall be divided equally between antennas

² Power levels are based on the assumption that multipath propagation conditions and noise source representing interference from other cells I_{oc} are turned on after the call set-up phase.

³ Power levels are based on the assumption that multipath propagation conditions and noise source representing interference from other cells I_{oc} are turned on after the call set-up phase.

E.3.5 Connection with closed loop transmit diversity mode

Table E.3.5 is applicable for measurements for subclause 7.6.2 (Demodulation of DCH in closed loop transmit diversity mode)

Table E.3.5: Downlink Physical Channels transmitted during a connection⁴

Physical Channel	Power	Note
CPICH (antenna 1)	CPICH_Ec1/Ior = -13 dB	1. Total CPICH_Ec/Ior = -10 dB
CPICH (antenna 2)	CPICH_Ec2/Ior = -13 dB	
PCCPCH (antenna 1)	PCCPCH_Ec1/Ior = -15 dB	1. STTD applied
PCCPCH (antenna 2)	PCCPCH_Ec2/Ior = -15 dB	1. STTD applied, total PCCPCH_Ec/Ior = -12 dB
SCH (antenna 1 / 2)	SCH_Ec/Ior = -12 dB	1. TSTD applied
PICH (antenna 1)	PICH_Ec1/Ior = -18 dB	1. STTD applied 2. STTD applied, total PICH_Ec/Ior = -15 dB
PICH (antenna 2)	PICH_Ec2/Ior = -18 dB	
DPCH	Test dependent power	1. Total power from both antennas
OCNS	Necessary power so that total transmit power spectral density of BS (Ior) adds to one	1. This power shall be divided equally between antennas

⁴ Power levels are based on the assumption that multipath propagation conditions and noise source representing interference from other cells Ioc are turned on after the call set-up phase.

Annex F (normative): Requirement of Test Equipment

[TBD]

Annex G (normative): Environmental conditions

G.1 General

This normative annex specifies the environmental requirements of the UE. Within these limits the requirements of this specifications shall be fulfilled.

G.2 Environmental requirements

The requirements in this clause apply to all types of UE(s)

G.2.1 Temperature

The UE shall fulfil all the requirements in the full temperature range of:

+15°C to + 35°C	for normal conditions (with relative humidity of 25 % to 75 %)
-10°C to + 55°C	for extreme conditions (see IEC publications 68-2-1 and 68-2-2)

Outside this temperature range the UE, if powered on, shall not make ineffective use of the radio frequency spectrum. In no case shall the UE exceed the transmitted levels as defined in [1] TS 25.101 for extreme operation.

G.2.2 Voltage

The UE shall fulfil all the requirements in the full voltage range, i.e. the voltage range between the extreme voltages.

The manufacturer shall declare the lower and higher extreme voltages and the approximate shutdown voltage. For the equipment that can be operated from one or more of the power sources listed below, the lower extreme voltage shall not be higher, and the higher extreme voltage shall not be lower than that specified below.

Power source	Lower extreme voltage	Higher extreme Voltage	Normal conditions voltage
AC mains	0,9 * nominal	1,1 * nominal	nominal
Regulated lead acid battery	0,9 * nominal	1,3 * nominal	1,1 * nominal
Non regulated batteries: - Leclanché / lithium - Mercury/nickel & cadmium	0,85 * nominal 0,90 * nominal	Nominal Nominal	Nominal Nominal

Outside this voltage range the UE if powered on, shall not make ineffective use of the radio frequency spectrum. In no case shall the UE exceed the transmitted levels as defined in [1] TS 25.101 for extreme operation. In particular, the UE shall inhibit all RF transmissions when the power supply voltage is below the manufacturer declared shutdown voltage.

G.2.3 Vibration

The UE shall fulfil all the requirements when vibrated at the following frequency/amplitudes:

Frequency	ASD (Acceleration Spectral Density) random vibration
5 Hz to 20 Hz	0,96 m ² /s ³
20 Hz to 500 Hz	0,96 m ² /s ³ at 20 Hz, thereafter –3 dB/Octave

Outside the specified frequency range the UE, if powered on, shall not make ineffective use of the radio frequency spectrum. In no case shall the UE exceed the transmitted levels as defined in [1] TS 25.101 for extreme operation

Annex H (normative): UE Capabilities (FDD)

H.1 Radio Access and RF Baseline Implementation Capabilities:

NOTES:

This clause shall be aligned with TR25.926, UE Radio Access Capabilities regarding FDD RF parameters. These RF UE Radio Access capabilities represent options in the UE, that require signalling to the network.

In addition there are options in the UE that do not require any signalling. They are designated as UE baseline capabilities, according to TR 21.904, Terminal Capability Requirements.

Table H.1 provides the list of UE radio access capability parameters and possible values.

Table H.1: RF UE Radio Access Capabilities

	UE radio access capability parameter	Value range
FDD RF parameters	UE power class (25.101 subclause 6.2.1)	3, 4
	Tx/Rx frequency separation for frequency band a) (25.101 subclause 5.3) Not applicable if UE is not operating in frequency band a)	190 MHz, 174,8-205,2 MHz, 134,8-245,2 MHz

Table H.2 provides the UE baseline implementation capabilities.

Table H.2: UE RF Baseline Implementation Capabilities

UE implementation capability	Value range
Radio frequency bands (25.101 subclause 5.2)	a), b), a+b)

- The special conformance testing functions and the logical test interface as specified in TS 34.109. This issue is currently under investigation.
- Uplink reference measurement channel 12,2 kbps (FDD), TS 25.101 subclause A.2.1
- Downlink reference measurement channel 12,2 kbps (FDD), TS 25.101 subclause A.3.1.

H.2 Service Implementation Capabilities:

- Uplink reference measurement channel 64 kbps (FDD), TS 25.101 subclause A.2.2
- Uplink reference measurement channel 144 kbps (FDD), TS 25.101 subclause A.2.3
- Uplink reference measurement channel 384 kbps (FDD), TS 25.101 subclause A.2.4
- Downlink reference measurement channel 64 kbps (FDD), TS 25.101 subclause A.3.2.
- Downlink reference measurement channel 144 kbps (FDD), TS 25.101 subclause A.3.3.
- Down-link reference measurement channel 384 kbps (FDD), TS 25.101 subclause A.3.4.

Annex I (informative): Open Items

(Sub)clause number	(Sub)clause description	Status
3.1	(Definitions, symbols, abbreviations and equations) Definitions	Definition of average power is TBD. (RAN WG4 issue)
4	Frequency bands and channel arrangement	Channel separation value to be tested.
		What channel No. (or Frequency) to be tested.
		Combination of these tests to be covered.
5.1	(Transmitter Characteristics) General	The necessity of the prescription for measurement period in each test should be examined. (RAN WG4 issue)
5.4.1.4 and 5.4.1.5	(Open Loop Power Control in the Uplink) Method of test, Test requirements	Test parameters in Table 5.4.1.3 should be examined.
5.4.2.4 and 5.4.2.5	(Inner Loop Power Control in the Uplink) Method of test, Test requirements	It was not clear if Algorithm 1 and 2 can be changed during connection. If not, steps-A to C, D to F and G to H should be tested separately.
5.4.2.4 and 5.4.2.5	(Inner Loop Power Control in the Uplink) Method of test, Test requirements	The additional procedure and test requirements for cycle time and response delay should be defined.
5.5.2.4	(Transmit ON/OFF Time mask) Method of test	A parameter in Table 5.5.2 is TBD.
5.6.2	(Change of TFC) Conformance requirements	One TBD in Table 5.6.2
5.7	Power setting in uplink compressed mode	Subclauses 5.7.4 and 5.7.5 are working assumptions. Consistency with RAN WG4 specifications should be checked.
5.11.4	(Spurious Emissions) Method of test	The definition for the response characteristics such as quasi-peak hold method is FFS.
5.13.2.1	(Peak code Domain error) Definition and applicability	The definition is not clear (error vector = $\frac{?}{\text{mean power of reference [dB]}}$). (depend on the future definition in TS 25.101)
5.13.2.2, 5.13.2.3 and 5.13.2.5	(Peak code Domain error) Conformance requirements, Test purpose, Test requirements	The requirement should be defined (currently []). (depend on the future definition in TS 25.101)
5.13.2.4	(Peak code Domain error) Method of test	The multi-code test conditions should be defined clearly. (depend on the future definition in TS 25.101)
6.8.2	(Spurious Emissions) Conformance requirements	100 kHz bandwidth for frequencies band from 9 kHz should be reviewed. (depend on the future definition in TS 25.101)
6.8.4	(Spurious Emissions) Method of test	The method to set Cell Search Mode should be defined.
6.8.4	(Spurious Emissions) Method of test	The definition for the response characteristics such as quasi-peak hold method is FFS.
7.1	(Performance requirements) General	The BLER target values for Moving and Birth / Death conditions should be defined. (depend on the future definition in TS 25.101)

(Sub)clause number	(Sub)clause description	Status
7.2.1.2	(Demodulation of Dedicated Channel) Conformance requirements	Parameter for Test 1 in Table 7.2.3.2 should be defined. (depend on the future definition in TS 25.101)
7.3.1.2	(Demodulation of DCH in Multi-path Fading Propagation conditions, Single Link Performance) Conformance requirements	Parameters in Table 7.3.1.2, Table 7.3.1.4 and Table 7.3.1.6 should be defined. (depend on the future definition in TS 25.101)
7.4.1.2	(Demodulation of DCH in Moving Propagation conditions, Single Link Performance) Conformance requirements	Parameters and requirements in Table 7.4.1.2 should be defined. (depend on the future definition in TS 25.101)
7.5.1.2	(Demodulation of DCH in Birth-Death Propagation conditions, Single Link Performance) Conformance requirements	Parameters and requirements in Table 7.5.1.2 should be defined. (depend on the future definition in TS 25.101)
7.6.1.2	(Demodulation of DCH in Base Station Transmit diversity modes, Demodulation of DCH in open-loop transmit diversity mode) Conformance requirements	Some parameters and requirements in Table 7.6.1.1 and 7.6.1.2 should be defined. (depend on the future definition in TS 25.101)
7.6.2.2	(Demodulation of DCH in Base Station Transmit diversity modes, Demodulation of DCH in feedback transmit diversity mode) Conformance requirements	Some parameters and requirements in Table 7.6.2.1 and 7.6.2.2 should be defined. (depend on the future definition in TS 25.101)
7.6.3.2	(Demodulation of DCH in Base Station Transmit diversity modes, Demodulation of DCH in Site Selection Diversity Transmission mode) Conformance requirements	Parameters in 7.6.3.2 should be defined. (depend on the future definition in TS 25.101)
7.7.1.2	(Demodulation in Handover conditions, Inter-Cell Soft Handover Performance) Conformance requirements	Some parameters and requirements in Table 7.7.1.1 and 7.7.1.2 should be defined. (depend on the future definition in TS 25.101)
7.7.1.4.1 and 7.7.1.5	(Demodulation in Handover conditions, Inter-Cell Soft Handover Performance) Initial conditions, Test requirements	TBD (quite empty)
7.8.2	(Inner loop power control in downlink) Conformance requirements	Some parameters and requirements in Table 7.8.1 and 7.8.2 should be defined. (depend on the future definition in TS 25.101)
7.8.4.2	(Inner loop power control in downlink) Procedure	It is FFS how does SS know UE has achieved the target BLER value.
7.9.2	(Outer loop power control in downlink) Conformance requirements	Some parameters and requirements in Table 7.9.1 and 7.9.2 should be defined. (depend on the future definition in TS 25.101)
7.9.5	(Outer loop power control in downlink) Test Requirements	TBD (quite empty) (depend on the definition of the Conformance requirements)
7.10.1.2	(Downlink compressed mode, Single link performance) Conformance requirements	Some parameters and requirements in Table 7.10.2 should be defined. (depend on the future definition in TS 25.101)
7.10.1.3, 7.10.4 and 7.10.5	(Downlink compressed mode, Single link performance) Test purpose, Method of test and Test Requirements	TBD (quite empty)
8.1 through 8.5	(Requirements for support of RRM) Genral, ..., Radio Link Surveillance	TBD (quite empty)
8.6.1.1.2	(Timing characteristics, Synchronization performance, Search of other Cells) Conformance requirements	The requirements and parameters in Table 8.6.1.1.1 should be defined. (depend on the future definition in TS 25.133)

(Sub)clause number	(Sub)clause description	Status
8.6.1.1.3, 8.6.1.1.4 and 8.6.1.1.5	(Timing characteristics, Synchronization performance, Search of other Cells) Test purpose, Method of test and Test requirements	TBD (almost empty)
8.6.2.1.3, 8.6.2.1.4 and 8.6.2.1.5	(Timing characteristics, Channel Timing Dependencies) Test purpose, Method of test, Test requirements	TBD (quite empty)
8.6.3.2	(Timing characteristics, Reception Timing) Conformance requirements	TBD (quite empty) (depend on the future definition in TS 25.133)
8.6.3.3, 8.6.3.4 and 8.6.3.5	(Timing characteristics, Reception Timing) Test purpose, Method of test, Test requirements	TBD (quite empty)
8.6.4	Signalling requirements	TBD (quite empty)
8.7	Measurements Performance Requirements	TBD (quite empty)
Annex F	Requirement of Test Equipment	TBD (quite empty)

Change History

Document history		
version	date (yyyy-mm-dd)	Comments
V0.0.0	1999-02-xx	Initial document. The contents are given from ARIB "Specification of Mobile Station for 3G Mobile System" (Ver.1.0-1.0)
V0.0.1	1999-03-26	Revised according to the results of TSG-T WG1 RF-Subgroup meeting #1 (March 10-11, 1999 Tokyo)
V1.0.0	1999-04-13	Revised from Tdoc T1R(99)022 according to the results of TSG-T WG1 RF-Subgroup meeting #2 (April 1-2, 1999 Tokyo)
V0.1.1	1999-05-14	The document numbering was changed from TS XX.XX to iTS-T1.003. The contents are revised from Tdoc T1-99040 according to the results of TSG-T1 meeting #2 and TSG-T1/RF-SWG meeting #3 (April 13-15, 1999 Paris)
V0.2.0	1999-06-14	Revised from Tdoc T1R(99)034 according to the results of TSG-T WG1 RF-Subgroup meeting #4 (May 14, 1999 Stockholm)
V1.0.0	1999-06-16	Approved as V1.0.0 by TSG-T1 meeting #3 in Miami. New document numbering and new title is given.
V1.0.0	1999-06-18	Noted by TSG T
V1.0.1	1999-06-24	Editorial changes to adapt to 3GPP template
V1.1.0	1999-07-29	Revised according to the results of TSG-T WG1 RF-Subgroup meeting #5 (June 14-16, 1999 Miami) and change of TS 25.101
V1.2.0	1999-09-13	Revised according to the result of TSG-T WG1 RF-Subgroup meeting #6 (July 29-30, 1999 South Queensferry) and changes of the core specifications
V1.3.0	1999-10-21	Revised according to the results of TSG-T WG1 RF-Subgroup meeting #7 (September 13-14, 1999 Kobe) and changes of the core specifications
V1.3.1	1999-11-24	Format updating
V1.4.0	1999-12-06	Revised according to the results of TSG-T WG1 RF-Subgroup meeting #8 (October 21-22, 1999 Sophia Antipolis) and changes of the core specifications
V1.5.0	1999-12-08	Revised according to the results of TSG-T WG1 RF-Subgroup meeting #9 (December 6-8, 1999 Sophia Antipolis)
V1.6.0	2000-02-21	Revised according to the results of TSG-T WG1 RF-Subgroup meeting #10 (January 24-26, 2000 @Morgan Hill, CA)
V1.7.0	2000-02-23	Revised according to the results of TSG-T WG1 RF-Subgroup meeting #11 (February 21-23, 2000 @Munich, Germany) [to be submitted to TSG T WG1 meeting #6]
V1.7.1	2000-02-23	Editorial changes. Presented to TSG T WG1 meeting #6 (February 24-25, 2000 @Munich, Germany)
V1.7.2	2000-02-28	Revised according to the results of TSG-T WG1 meeting #6 and sent to the e-mail reflector for approval as V2.0.0
V1.7.3	2000-03-04	Revised according to the e-mail reflector discussion for approval as V2.0.0
V2.0.0	2000-03-06	Approved as 2.0.0 + format update.
V3.0.0	2000-03-13	Approved as v3.0.0 at TSG T#7
V3.0.1	2000-03-31	No change: replaces invalid zip file on server
Editor for Terminal Conformance Specification; Radio transmission and reception (FDD) Kenji Higuchi ADVANTEST Corporation Tel: +81-48-556-6500 Fax: +81-48-554-6833 E-mail: higuchi@gtmi.advantest.co.jp This document is written in Microsoft® Word 97.		

History

Document history		
V3.0.1	March 2000	Publication