

ETSI TS 134 121 V3.4.0 (2001-03)

Technical Specification

**Universal Mobile Telecommunications System (UMTS);
Terminal Conformance Specification;
Radio Transmission and Reception (FDD)
(3GPP TS 34.121 version 3.4.0 Release 1999)**



Reference

RTS/TSGT-0134121UR4

Keywords

UMTS

ETSI

650 Route des Lucioles
F-06921 Sophia Antipolis Cedex - FRANCE

Tel.: +33 4 92 94 42 00 Fax: +33 4 93 65 47 16

Siret N° 348 623 562 00017 - NAF 742 C
Association à but non lucratif enregistrée à la
Sous-Préfecture de Grasse (06) N° 7803/88

Important notice

Individual copies of the present document can be downloaded from:

<http://www.etsi.org>

The present document may be made available in more than one electronic version or in print. In any case of existing or perceived difference in contents between such versions, the reference version is the Portable Document Format (PDF). In case of dispute, the reference shall be the printing on ETSI printers of the PDF version kept on a specific network drive within ETSI Secretariat.

Users of the present document should be aware that the document may be subject to revision or change of status. Information on the current status of this and other ETSI documents is available at <http://www.etsi.org/tb/status/>

If you find errors in the present document, send your comment to:
editor@etsi.fr

Copyright Notification

No part may be reproduced except as authorized by written permission.
The copyright and the foregoing restriction extend to reproduction in all media.

© European Telecommunications Standards Institute 2001.

All rights reserved.

Intellectual Property Rights

IPRs essential or potentially essential to the present document may have been declared to ETSI. The information pertaining to these essential IPRs, if any, is publicly available for **ETSI members and non-members**, and can be found in ETSI SR 000 314: "*Intellectual Property Rights (IPRs); Essential, or potentially Essential, IPRs notified to ETSI in respect of ETSI standards*", which is available from the ETSI Secretariat. Latest updates are available on the ETSI Web server (<http://www.etsi.org/ipr>).

Pursuant to the ETSI IPR Policy, no investigation, including IPR searches, has been carried out by ETSI. No guarantee can be given as to the existence of other IPRs not referenced in ETSI SR 000 314 (or the updates on the ETSI Web server) which are, or may be, or may become, essential to the present document.

Foreword

This Technical Specification (TS) has been produced by the ETSI 3rd Generation Partnership Project (3GPP).

The present document may refer to technical specifications or reports using their 3GPP identities, UMTS identities or GSM identities. These should be interpreted as being references to the corresponding ETSI deliverables.

The cross reference between GSM, UMTS, 3GPP and ETSI identities can be found under www.etsi.org/key.

Contents

Foreword.....	13
1 Scope	14
2 References	14
3 Definitions, symbols, abbreviations and equations	14
3.1 Definitions.....	14
3.2 Symbols.....	15
3.3 Abbreviations	15
3.4 Equations.....	16
4 Frequency bands and channel arrangement.....	17
4.1 General.....	17
4.2 Frequency bands.....	17
4.3 TX–RX frequency separation.....	17
4.4 Channel arrangement	17
4.4.1 Channel spacing.....	17
4.4.2 Channel raster.....	17
4.4.3 Channel number.....	17
5 Transmitter Characteristics.....	18
5.1 General	18
5.2 Maximum Output Power.....	18
5.2.1 Definition and applicability	18
5.2.2 Minimum Requirements	18
5.2.3 Test purpose	19
5.2.4 Method of test.....	19
5.2.4.1 Initial conditions.....	19
5.2.4.2 Procedure.....	19
5.2.5 Test requirements	19
5.3 Frequency Error	20
5.3.1 Definition and applicability	20
5.3.2 Minimum Requirements	20
5.3.3 Test purpose	20
5.3.4 Method of test.....	20
5.3.5 Test Requirements	21
5.4 Output Power Dynamics in the Uplink	21
5.4.1 Open Loop Power Control in the Uplink.....	21
5.4.1.1 Definition and applicability	21
5.4.1.2 Conformance requirements.....	21
5.4.1.3 Test purpose	21
5.4.1.4 Method of test.....	21
5.4.1.5 Test requirements	22
5.4.2 Inner Loop Power Control in the Uplink.....	23
5.4.2.1 Definition and applicability	23
5.4.2.2 Conformance requirements.....	23
5.4.2.3 Test purpose	24
5.4.2.4 Method of test.....	24
5.4.2.5 Test requirements	26
5.4.3 Minimum Output Power.....	27
5.4.3.1 Definition and applicability	27
5.4.3.2 Minimum Requirements	27
5.4.3.3 Test purpose	27
5.4.3.4 Method of test.....	28
5.4.3.5 Test requirements	28
5.4.4 Out-of-synchronisation handling of output power.....	28
5.4.4.1 Definition and applicability	28
5.4.4.2 Minimum Requirements	28

5.4.4.3	Test purpose	29
5.4.4.4	Method of test.....	30
5.4.4.5	Test requirements	30
5.5	Transmit ON/OFF Power	31
5.5.1	Transmit OFF Power	31
5.5.1.1	Definition and applicability	31
5.5.1.2	Minimum Requirements	31
5.5.1.3	Test purpose	31
5.5.1.4	Method of test.....	31
5.5.1.4.1	Initial conditions	31
5.5.1.4.2	Procedure	31
5.5.1.5	Test requirements	31
5.5.2	Transmit ON/OFF Time mask.....	32
5.5.2.1	Definition and applicability	32
5.5.2.2	Conformance requirements.....	32
5.5.2.3	Test purpose	33
5.5.2.4	Method of test.....	33
5.5.2.5	Test requirements	34
5.6	Change of TFC.....	34
5.6.1	Definition and applicability	34
5.6.2	Conformance requirements.....	35
5.6.3	Test purpose	36
5.6.4	Method of test.....	36
5.6.5	Test requirements	36
5.7	Power setting in uplink compressed mode	37
5.7.1	Definition and applicability	37
5.7.2	Conformance requirements.....	37
5.7.3	Test purpose	38
5.7.4	Method of test.....	39
5.7.5	Test requirements	42
5.8	Occupied Bandwidth (OBW)	43
5.8.1	Definition and applicability	43
5.8.2	Minimum Requirements	43
5.8.3	Test purpose	43
5.8.4	Method of test.....	43
5.8.5	Test Requirements	44
5.9	Spectrum emission mask	44
5.9.1	Definition and applicability	44
5.9.2	Minimum Requirements	44
5.9.3	Test purpose	44
5.9.4	Method of test.....	45
5.9.4.1	Initial conditions	45
5.9.4.2	Procedure.....	45
5.9.5	Test requirements	45
5.10	Adjacent Channel Leakage Power Ratio (ACLR).....	46
5.10.1	Definition and applicability	46
5.10.2	Minimum Requirements	46
5.10.3	Test purpose	46
5.10.4	Method of test.....	46
5.10.5	Test requirements	47
5.11	Spurious Emissions	47
5.11.1	Definition and applicability	47
5.11.2	Minimum Requirements	47
5.11.3	Test purpose	48
5.11.4	Method of test.....	48
5.11.5	Test requirements	48
5.12	Transmit Intermodulation	49
5.12.1	Definition and applicability	49
5.12.2	Minimum Requirements	49
5.12.3	Test purpose	49
5.12.4	Method of test.....	49
5.12.5	Test requirements	50

5.13	Transmit Modulation	50
5.13.1	Error Vector Magnitude (EVM)	50
5.13.1.1	Definition and applicability	50
5.13.1.2	Minimum Requirements	50
5.13.1.3	Test purpose	50
5.13.1.4	Method of test	50
5.13.1.5	Test requirements	51
5.13.2	Peak code domain error	51
5.13.2.1	Definition and applicability	51
5.13.2.2	Minimum Requirements	51
5.13.2.3	Test purpose	51
5.13.2.4	Method of test	52
5.13.2.5	Test requirements	52
6	Receiver Characteristics	53
6.1	General	53
6.2	Reference Sensitivity Level	53
6.2.1	Definition and applicability	53
6.2.2	Minimum Requirements	53
6.2.3	Test purpose	54
6.2.4	Method of test	54
6.2.5	Test requirements	54
6.3	Maximum Input Level	54
6.3.1	Definition and applicability	54
6.3.2	Conformance requirements	54
6.3.3	Test purpose	55
6.3.4	Method of test	55
6.3.5	Test requirements	55
6.4	Adjacent Channel Selectivity (ACS)	55
6.4.1	Definition and applicability	55
6.4.2	Minimum Requirements	56
6.4.3	Test purpose	56
6.4.4	Method of test	56
6.4.5	Test requirements	56
6.5	Blocking Characteristics	57
6.5.1	Definition and applicability	57
6.5.2	Minimum Requirements	57
6.5.3	Test purpose	58
6.5.4	Method of test	58
6.5.5	Test requirements	58
6.6	Spurious Response	59
6.6.1	Definition and applicability	59
6.6.2	Minimum Requirements	59
6.6.3	Test purpose	60
6.6.4	Method of test	60
6.6.4.1	Initial conditions	60
6.6.4.2	Procedure	60
6.6.5	Test requirements	60
6.7	Intermodulation Characteristics	60
6.7.1	Definition and applicability	60
6.7.2	Minimum Requirements	60
6.7.3	Test purpose	61
6.7.4	Method of test	61
6.7.5	Test requirements	61
6.8	Spurious Emissions	62
6.8.1	Definition and applicability	62
6.8.2	Minimum Requirements	62
6.8.3	Test purpose	62
6.8.4	Method of test	62
6.8.5	Test requirements	63

7	Performance requirements	63
7.1	General	63
7.1.1	Measurement Configurations	64
7.2	Demodulation in Static Propagation conditions	64
7.2.1	Demodulation of Dedicated Channel (DCH)	64
7.2.1.1	Definition and applicability	64
7.2.1.2	Conformance requirements	64
7.2.1.3	Test purpose	65
7.2.1.4	Method of test	65
7.2.1.5	Test requirements	65
7.3	Demodulation of DCH in Multi-path Fading Propagation conditions	65
7.3.1	Single Link Performance	65
7.3.1.1	Definition and applicability	65
7.3.1.2	Conformance requirements	65
7.3.1.3	Test purpose	67
7.3.1.4	Method of test	68
7.3.1.5	Test requirements	68
7.4	Demodulation of DCH in Moving Propagation conditions	68
7.4.1	Single Link Performance	68
7.4.1.1	Definition and applicability	68
7.4.1.2	Conformance requirements	68
7.4.1.3	Test purpose	69
7.4.1.4	Method of test	69
7.4.1.5	Test requirements	69
7.5	Demodulation of DCH in Birth-Death Propagation conditions	69
7.5.1	Single Link Performance	69
7.5.1.1	Definition and applicability	69
7.5.1.2	Conformance requirements	69
7.5.1.3	Test purpose	70
7.5.1.4	Method of test	70
7.5.1.5	Test requirements	70
7.6	Demodulation of DCH in Base Station Transmit diversity modes	70
7.6.1	Demodulation of DCH in open-loop transmit diversity mode	70
7.6.1.1	Definition and applicability	70
7.6.1.2	Conformance requirements	71
7.6.1.3	Test purpose	71
7.6.1.4	Method of test	71
7.6.1.5	Test Requirements	71
7.6.2	Demodulation of DCH in closed loop transmit diversity mode	72
7.6.2.1	Definition and applicability	72
7.6.2.2	Conformance requirements	72
7.6.2.3	Test purpose	72
7.6.2.4	Method of test	72
7.6.2.5	Test Requirements	73
7.6.3	Demodulation of DCH in Site Selection Diversity Transmission Power Control mode	73
7.6.3.1	Definition and applicability	73
7.6.3.2	Conformance requirements	73
7.6.3.3	Test purpose	74
7.6.3.4	Method of test	74
7.6.3.5	Test Requirements	74
7.7	Demodulation in Handover conditions	74
7.7.1	Demodulation of DCH in Inter-Cell Soft Handover	74
7.7.1.1	Definition and applicability	74
7.7.1.2	Conformance requirements	75
7.7.1.3	Test purpose	75
7.7.1.4	Method of test	75
7.7.1.5	Test requirements	76
7.7.2	Combining of TPC commands from radio links of different radio link sets	76
7.7.2.1	Definition and applicability	76
7.7.2.2	Conformance requirements	76
7.7.2.3	Test purpose	77
7.7.2.4	Method of test	77

7.7.2.5	Test requirements	78
7.8	Power control in downlink	78
7.8.1	Power control in the downlink, constant BLER target	78
7.8.1.1	Definition and applicability	78
7.8.1.2	Conformance requirements.....	79
7.8.1.3	Test purpose	79
7.8.1.4	Method of test.....	79
7.8.1.5	Test Requirements	80
7.8.2	Power control in the downlink, initial convergence	80
7.8.2.1	Definition and applicability	80
7.8.2.2	Conformance requirements.....	80
7.8.2.3	Test purpose	81
7.8.2.4	Method of test.....	81
7.8.2.5	Test Requirements	81
7.8.3	Power control in the downlink, wind up effects	81
7.8.3.1	Definition and applicability	81
7.8.3.2	Conformance requirements.....	82
7.8.3.3	Test purpose	82
7.8.3.4	Method of test.....	82
7.8.3.5	Test Requirements	83
7.9	Downlink compressed mode	83
7.9.1	Single link performance.....	83
7.9.1.1	Definition and applicability	83
7.9.1.2	Conformance requirements.....	83
7.9.1.3	Test purpose	84
7.9.1.4	Method of test.....	84
7.9.1.5	Test requirements	85
7.10	Blind transport format detection.....	85
7.10.1	Definition and applicability	85
7.10.2	Conformance requirements.....	85
7.10.3	Test purpose	86
7.10.4	Method of test.....	86
7.10.5	Test requirements	86
8	Requirements for support of RRM.....	87
8.1	General.....	87
8.2	Idle Mode Tasks.....	87
8.2.1	Cell Selection	87
8.2.1.1	Cell Selection; the cells in the neighbour list belong to different frequencies.....	87
8.2.1.1.1	Definition and applicability	87
8.2.1.1.2	Conformance requirement.....	87
8.2.1.1.3	Test purpose.....	87
8.2.1.1.4	Method of test	87
8.2.1.1.5	Test requirements.....	88
8.2.1.2	Cell Selection; no cell is present in the neighbour list.....	89
8.2.1.2.1	Definition and applicability	89
8.2.1.2.2	Conformance requirement.....	89
8.2.1.2.3	Test purpose.....	89
8.2.1.2.4	Method of test	89
8.2.1.2.5	Test requirements.....	90
8.2.2	Cell Re-Selection.....	90
8.2.2.1	Cell Re-Selection; single carrier case.....	90
8.2.2.1.1	Definition and applicability	90
8.2.2.1.2	Conformance requirement.....	90
8.2.2.1.3	Test purpose.....	90
8.2.2.1.4	Method of test	90
8.2.2.1.5	Test requirements	93
8.2.2.2	Cell Re-Selection; multi carrier case	93
8.2.2.2.1	Definition and applicability	93
8.2.2.2.2	Conformance requirement.....	93
8.2.2.2.3	Test purpose.....	93
8.2.2.2.4	Method of test	93

8.2.2.2.5	Test requirements	94
8.2.3	UTRAN to GSM Cell Re-Selection	95
8.2.3.1	Definition and applicability	95
8.2.3.2	Conformance requirement	95
8.2.3.3	Test purpose	95
8.2.3.4	Method of test.....	95
8.2.3.5	Test requirements	97
8.3	UTRAN Connected mode mobility.....	97
8.3.1	FDD/FDD Soft Handover.....	97
8.3.1.1	Active set dimension	97
8.3.1.2	Active set update delay.....	97
8.3.2	FDD/FDD Hard Handover	97
8.3.2.1	Hard handover delay.....	97
8.3.2.2	Interruption time	97
8.3.3	FDD/TDD Handover	97
8.3.3.1	Hard handover delay.....	97
8.3.3.2	Interruption time	97
8.3.4	FDD/GSM Handover.....	97
8.3.4.1	Inter-system handover delay.....	97
8.3.4.2	Interruption time	97
8.3.5	Cell Re-selection in CELL_FACH.....	98
8.3.5.1	All cells in the neighbour list belong to the same frequency	98
8.3.5.2	The cells in the neighbour list belong to different frequencies.....	98
8.3.6	Cell Re-selection in CELL_PCH.....	98
8.3.6.1	All cells in the neighbour list belong to the same frequency	98
8.3.6.2	The cells in the neighbour list belong to different frequencies.....	98
8.3.7	Cell Re-selection in URA_PCH	98
8.3.7.1	All cells in the neighbour list belong to the same frequency	98
8.3.7.2	The cells in the neighbour list belong to different frequencies.....	98
8.4	RRC Connection Control	98
8.4.1	RRC Re-establishment	98
8.4.1.1	Target cell known by UE.....	98
8.4.1.2	Target cell not known by UE.....	98
8.4.2	Spare.....	98
8.4.3	Random Access	98
8.4.3.1	Correct behaviour when receiving an ACK.....	98
8.4.3.2	Correct behaviour when receiving an NACK.....	98
8.4.3.3	Correct behaviour at Time-out	99
8.4.3.4	Correct behaviour when reaching maximum transmit power.....	99
8.4.4	Transport format combination selection in UE.....	99
8.5	Timing and Signalling characteristics	99
8.5.1	UE Transmit Timing.....	99
8.5.1.1	Initial transmission timing, Maximum timing adjustment size and Maximum timing adjustment rate.....	99
8.5.1.1.1	Definition and applicability	99
8.5.1.1.2	Conformance requirements	99
8.5.1.1.3	Test purpose.....	100
8.5.1.1.4	Method of test	100
8.5.1.1.4.1	Initial conditions	100
8.5.1.1.4.2	Procedures.....	100
8.5.1.1.5	Test requirements.....	100
8.5.2	Signalling Response Delay.....	100
8.5.3	Signalling Processing	100
8.6	UE Measurements Procedures	100
8.6.1	Measurements in CELL_DCH State	100
8.6.1.1	FDD intra frequency measurements	100
8.6.1.1.1	Identification of a new cell.....	100
8.6.1.1.2	UE CPICH measurement capability.....	100
8.6.1.1.3	Periodic Reporting	100
8.6.1.1.4	Event Triggered Periodic Reporting	100
8.6.1.1.5	Event Triggered Reporting.....	100
8.6.1.2	FDD inter frequency measurements	100
8.6.1.2.1	Identification of a new cell.....	100

8.6.1.2.2	Measurement period.....	101
8.6.1.2.3	Periodic Reporting	101
8.6.1.2.4	Event Triggered Reporting.....	101
8.6.1.3	TDD measurements	101
8.6.1.3.1	Periodic Reporting	101
8.6.1.3.2	Event Triggered Reporting.....	101
8.6.1.4	GSM measurements.....	101
8.6.1.4.1	GSM carrier RSSI.....	101
8.6.1.4.2	BSIC verification	101
8.6.1.4.2.1	Initial BSIC verification.....	101
8.6.1.4.2.2	BSIC re-confirmation.....	101
8.6.2	Parallel Measurements in CELL_DCH State	101
8.6.3	Measurements in CELL_FACH State	101
8.7	Measurements Performance Requirements	101
8.7.1	CPICH RSCP	101
8.7.1.1	Intra frequency measurements accuracy.....	101
8.7.1.1.1	Absolute accuracy requirement.....	101
8.7.1.1.2	Relative accuracy requirement.....	102
8.7.1.2	Inter frequency measurement accuracy	102
8.7.1.2.1	Relative accuracy requirement.....	102
8.7.1.3	CPICH RSCP measurement report mapping	102
8.7.2	CPICH Ec/Io.....	102
8.7.2.1	Intra frequency measurements accuracy.....	102
8.7.2.1.1	Absolute accuracy requirement.....	102
8.7.2.1.2	Relative accuracy requirement.....	102
8.7.2.2	Inter frequency measurement accuracy	102
8.7.2.2.1	Relative accuracy requirement.....	102
8.7.2.3	CPICH Ec/Io measurement report mapping	102
8.7.3	UTRA Carrier RSSI	102
8.7.3.1	Absolute accuracy requirement	102
8.7.3.2	Relative accuracy requirement	102
8.7.3.3	UTRA Carrier RSSI measurement report mapping	102
8.7.4	GSM carrier RSSI.....	102
8.7.5	Transport channel BLER	103
8.7.5.1	BLER measurement requirement	103
8.7.5.2	Transport channel BLER measurement report mapping	103
8.7.6	UE transmitted power.....	103
8.7.6.1	Accuracy requirement	103
8.7.6.2	UE transmitted power measurement report mapping	103
8.7.7	SFN-CFN observed time difference	103
8.7.7.1	Intra frequency measurement requirement	103
8.7.7.2	Inter frequency measurement requirement	103
8.7.7.3	SFN-CFN observed time difference measurement report mapping.....	103
8.7.8	SFN-SFN observed time difference.....	103
8.7.8.1	SFN-SFN observed time difference type 1.....	103
8.7.8.1.1	Measurement requirement.....	103
8.7.8.1.2	SFN-SFN observed time difference type 1 measurement report mapping.....	103
8.7.8.2	SFN-SFN observed time difference type 2.....	103
8.7.8.2.1	Intra frequency measurement requirement accuracy without IPDL period active.....	103
8.7.8.2.2	Intra frequency measurement requirement accuracy with IPDL period active	103
8.7.8.2.3	Inter frequency measurement requirement accuracy.....	104
8.7.8.2.4	SFN-SFN observed time difference type 2 measurement report mapping.....	104
8.7.9	UE Rx-Tx time difference	104
8.7.9.1	Measurement requirement	104
8.7.9.2	UE Rx-Tx time difference measurement report mapping.....	104
8.7.10	Observed time difference to GSM cell	104
8.7.10.1	Measurement requirement.....	104
8.7.10.2	Observed time difference to GSM cell measurement report mapping	104
8.7.11	P-CCPCH RSCP.....	104
8.7.11.1	Absolute accuracy requirements	104
8.7.11.2	P-CCPCH RSCP measurement report mapping.....	104
8.7.12	UE GPS Timing of Cell Frames for LCS	104

8.7.12.1	UE GPS timing of Cell Frames for LCS measurement report mapping	104
Annex A (informative):	Connection Diagrams	105
Annex B (normative):	Global In-Channel TX-Test	111
B.1	General	111
B.2	Definition of the process	111
B.2.1	Basic principle	111
B.2.2	Output signal of the TX under test	111
B.2.3	Reference signal	111
B.2.4	void	112
B.2.5	Classification of measurement results	112
B.2.6	Process definition to achieve results of type "deviation"	112
B.2.7	Process definition to achieve results of type "residual"	112
B.2.7.1	Error Vector Magnitude (EVM)	113
B.2.7.2	Peak Code Domain Error (PCDE)	113
B.3	Notes	114
Annex C (normative):	Measurement channels	116
C.1	General	116
C.2	UL reference measurement channel	116
C.2.1	UL reference measurement channel (12.2 kbps)	116
C.2.2	UL reference measurement channel (64 kbps)	117
C.2.3	UL reference measurement channel (144 kbps)	118
C.2.4	UL reference measurement channel (384 kbps)	119
C.2.5	UL reference measurement channel (768 kbps)	120
C.3	DL reference measurement channel	121
C.3.1	DL reference measurement channel (12.2 kbps)	121
C.3.2	DL reference measurement channel (64 kbps)	122
C.3.3	DL reference measurement channel (144 kbps)	123
C.3.4	DL reference measurement channel (384 kbps)	124
C.4	Reference measurement channel for BTFD performance requirements	125
C.4.1	UL reference measurement channel for BTFD performance requirements	125
C.4.2	DL reference measurement channel for BTFD performance requirements	126
C.5	DL reference compressed mode parameters	127
Annex D (normative):	Propagation Conditions	129
D.1	General	129
D.2	Propagation Conditions	129
D.2.1	Static propagation condition	129
D.2.2	Multi-path fading propagation conditions	129
D.2.3	Moving propagation conditions	129
D.2.4	Birth-Death propagation conditions	130
Annex E (normative):	Downlink Physical Channels	131
E.1	General	131
E.2	Connection Set-up	131
E.2.1	Measurement without dedicated connection	131
E.3	During connection	131
E.3.1	Measurement of Tx Characteristics	131
E.3.2	Measurement of Rx Characteristics	132
E.3.3	Measurement of Performance requirements	132
E.3.4	Connection with open-loop transmit diversity mode	134
E.3.5	Connection with closed loop transmit diversity mode	135

Annex F (normative):	General test conditions and declarations	136
F.1	Acceptable uncertainty of Test System	136
F.1.1	Measurement of test environments	136
F.1.2	Measurement of transmitter	137
F.1.3	Measurement of receiver	138
F.1.4	Performance requirement	138
F.1.5	Requirements for support of RRM	139
F.2	Test Tolerances (This subclause is informative)	139
F.2.1	Transmitter	139
F.2.2	Receiver	140
F.2.3	Performance requirements	140
F.2.4	Requirements for support of RRM	140
F.3	Interpretation of measurement results	140
F.4	Derivation of Test Requirements (This subclause is informative)	141
F.5	Acceptable uncertainty of Test Equipment (This subclause is informative)	144
F.5.1	Transmitter measurements	145
F.5.2	Receiver measurements	146
F.5.3	Performance measurements	146
F.6	General rules for statistical testing	146
Annex G (normative):	Environmental conditions	147
G.1	General	147
G.2	Environmental requirements	147
G.2.1	Temperature	147
G.2.2	Voltage	147
G.2.3	Vibration	148
Annex H (normative):	UE Capabilities (FDD).....	149
H.1	Radio Access and RF Baseline Implementation Capabilities:	149
H.2	Service Implementation Capabilities:.....	149
Annex I (informative):	Test cases requiring evaluation for applicability	150
I.1	General	150
I.2	Synchronization performance.....	150
8.5.1	Synchronization performance.....	150
8.5.1.1	Search of other Cells	150
8.5.1.1.1	Definition and applicability	150
8.5.1.1.2	Conformance requirements	150
8.5.1.1.3	Test purpose	150
8.5.1.1.4	Method of test	150
8.5.1.1.4.1	Initial conditions	150
8.5.1.1.4.2	Procedures.....	151
8.5.1.1.5	Test requirements.....	151
I.3	Reception timing	151
8.5.4	Reception Timing	151
8.5.4.1	Definition and applicability	151
8.5.4.2	Conformance requirements.....	151
8.5.4.3	Test purpose	151
8.5.4.4	Method of test.....	151
8.5.4.4.1	Initial conditions	151
8.5.4.4.2	Procedures.....	151
8.5.4.5	Test requirements	151

Annex J (informative): Information about special regional application of test cases and requirements..... 152

J.1 Japan..... 152

Annex K (informative): Change history 153

Foreword

This Technical Specification has been produced by the 3rd Generation Partnership Project (3GPP).

The contents of the present document are subject to continuing work within the TSG and may change following formal TSG approval. Should the TSG modify the contents of the present document, it will be re-released by the TSG with an identifying change of release date and an increase in version number as follows:

Version x.y.z

where:

- x the first digit:
 - 1 presented to TSG for information;
 - 2 presented to TSG for approval;
 - 3 or greater indicates TSG approved document under change control.
- y the second digit is incremented for all changes of substance, i.e. technical enhancements, corrections, updates, etc.
- z the third digit is incremented when editorial only changes have been incorporated in the document.

1 Scope

The present document specifies the measurement procedures for the conformance test of the user equipment (UE) that contain transmitting characteristics, receiving characteristics and performance requirements in FDD mode.

2 References

The following documents contain provisions which, through reference in this text, constitute provisions of the present document.

- References are either specific (identified by date of publication, edition number, version number, etc.) or non-specific.
- For a specific reference, subsequent revisions do not apply.
- For a non-specific reference, the latest version applies. In the case of a reference to a 3GPP document (including a GSM document), a non-specific reference implicitly refers to the latest version of that document in the same Release as the present document.

- [1] 3GPP TS 25.101 "UE Radio transmission and reception (FDD)".
- [2] 3GPP TS 25.133 "Requirements for Support of Radio Resource Management (FDD)".
- [3] 3GPP TS 34.108 "Common Test Environments for User Equipment (UE) Conformance Testing".
- [4] 3GPP TS 34.109 "Logical Test Interface; Special conformance testing functions".
- [5] 3GPP TS 25.214 "Physical layer procedures (FDD)".
- [6] 3GPP TR 21.905 "Vocabulary for 3GPP Specifications".
- [7] 3GPP TR 25.990 "Vocabulary".
- [8] 3GPP TS 25.331: "Radio Resource Control (RRC) Protocol Specification".
- [9] 3GPP TS 25.433 "UTRAN Iub Interface NBAP Signalling".
- [10] 3GPP TS 25.141: "Base station conformance testing (FDD)".

3 Definitions, symbols, abbreviations and equations

Definitions, symbols, abbreviations and equations used in the present document are listed in TR 21.905 [5] and TR 25.990 [6].

Terms are listed in alphabetical order in this clause.

3.1 Definitions

For the purpose of the present document, the following additional terms and definitions apply:

Average power: [TBD]

3.2 Symbols

For the purposes of the present document, the following symbols apply:

[...]: Values included in square bracket must be considered for further studies, because it means that a decision about that value was not taken;

3.3 Abbreviations

For the purpose of the present document, the following additional abbreviations apply:

AFC: Automatic Frequency Control

ASD: Acceleration Spectral Density

ATT: Attenuator

BER: Bit Error Ratio

BLER: Block Error Ratio

BTFD: Blind Transport Format Detection

EVM: Error Vector Magnitude

FDR: False transmit format Detection Ratio

HYB: Hybrid

IM: Intermodulation

ITP: Initial Transmission Power control mode

OBW: Occupied Bandwidth

OCNS: Orthogonal Channel Noise Simulator, a mechanism used to simulate the users or control signals on the other orthogonal channels of a downlink

PAR: Peak to Average Ratio

P-CCPCH: Primary Common Control Physical Channel

P-CPICH: Primary Common Pilot Channel

PCDE: Peak Code Domain Error

RBW: Resolution Bandwidth

RRC: Root-Raised Cosine

S-CCPCH: Secondary Common Control Physical Channel

S-CPICH: Secondary Common Pilot Channel

SCH: Synchronisation Channel consisting of Primary and Secondary synchronisation channels

SS: System Simulator

TGCFN: Transmission Gap Connection Frame Number

TGD: Transmission Gap Distance

TGL: Transmission Gap Length

TGPL: Transmission Gap Pattern Length

TGPRC: Transmission Gap Pattern Repetition Count

TGSN: Transmission Gap Starting Slot Number

3.4 Equations

For the purpose of the present document, the following additional equations apply:

$\frac{CPICH_E_c}{I_{or}}$ The ratio of the received energy per PN chip of the CPICH to the total transmit power spectral density at the Node B (SS) antenna connector.

$\frac{DPCH_E_c}{I_{or}}$ The ratio of the transmit energy per PN chip of the DPCH to the total transmit power spectral density at the Node B (SS) antenna connector.

$\frac{DPCCH_E_c}{I_{or}}$ The ratio of the transmit energy per PN chip of the DPCCH to the total transmit power spectral density at the Node B (SS) antenna connector.

$\frac{DPDCH_E_c}{I_{or}}$ The ratio of the transmit energy per PN chip of the DPDCH to the total transmit power spectral density at the Node B (SS) antenna connector.

F_{uw} Frequency of unwanted signal. This is specified in bracket in terms of an absolute frequency(s) or a frequency offset from the assigned channel frequency.

I_{Node_B} Interference signal power level at Node B in dBm, which is broadcasted on BCH.

I_{oac} The power spectral density of the adjacent frequency channel as measured at the UE antenna connector.

I_{oc} The power spectral density of a band limited white noise source (simulating interference from cells, which are not defined in a test procedure) as measured at the UE antenna connector.

I_{or} The received power spectral density of the down link as measured at the UE antenna connector.

I_{ouw} Unwanted signal power level.

$P\text{-}CCPCH_E_c$ Average* energy per PN chip for P-CCPCH.

$P\text{-}CCPCH \frac{E_c}{I_o}$ The ratio of the received P-CCPCH energy per chip to the total received power spectral density at the UE antenna connector.

$\frac{P\text{-}CCPCH_E_c}{I_{or}}$ The ratio of the average* transmit energy per PN chip for the P-CCPCH to the total transmit power spectral density.

$P\text{-}CPICH_E_c$ Average* energy per PN chip for P-CPICH.

$PICH_E_c$ Average* energy per PN chip for PICH.

$\frac{PICH_E_c}{I_{or}}$ The ratio of the received energy per PN chip of the PICH to the total transmit power spectral density at the Node B (SS) antenna connector.

SCH_E_c Average* energy per PN chip for SCH.

$S\text{-}CPICH_E_c$ Average* energy per PN chip for S-CPICH.

*Note: Averaging period for energy/power of discontinuously transmitted channels should be defined.

4 Frequency bands and channel arrangement

4.1 General

The information presented in this clause is based on a chip rate of 3.14 Mcps.

NOTE: Other chip rates may be considered in future releases.

4.2 Frequency bands

UTRA/FDD is designed to operate in either of the following paired bands;

- (a) 1920 – 1980MHz: Up-link (Mobile transmit, base receive)
2110 – 2170MHz: Down-link (Base transmit, mobile receive)
- (b)* 1850 – 1910MHz: Up-link (Mobile transmit, base receive)
1930 – 1990MHz: Down-link (Base transmit, mobile receive)

* Used in Region 2.

Additional allocations in ITU region 2 are FFS.

Deployment in other frequency bands is not precluded.

4.3 TX–RX frequency separation

- a) The minimum transmit to receive frequency separation is 134.8 MHz and the maximum value is 245.2 MHz and all UE(s) shall support a TX–RX frequency separation of 190 MHz when operating in the paired band defined in subclause 4.2 (a).
- b) When operating in the paired band defined in subclause 4.2 (b), all UE(s) shall support a TX-RX frequency separation of 80 MHz.
- c) UTRA/FDD can support both fixed and variable transmit to receive frequency separation.
- d) The use of other transmit to receive frequency separations in existing or other frequency bands shall not be precluded.

4.4 Channel arrangement

4.4.1 Channel spacing

The nominal channel spacing is 5 MHz, but this can be adjusted to optimise performance in a particular deployment scenario.

4.4.2 Channel raster

The channel raster is 200 kHz, which means that the centre frequency must be an integer multiple of 200 kHz.

4.4.3 Channel number

The carrier frequency is designated by the UTRA Absolute Radio Frequency Channel Number (UARFCN). The value of the UARFCN in the IMT-2000 band is defined as follows;

Table 4.1: UTRA Absolute Radio Frequency Channel Number

Uplink	$N_u = 5 * F_{\text{uplink}}$	$0.0 \text{ MHz} \leq F_{\text{uplink}} \leq 3276.6 \text{ MHz}$ where F_{uplink} is the uplink frequency in MHz
Downlink	$N_d = 5 * F_{\text{downlink}}$	$0.0 \text{ MHz} \leq F_{\text{downlink}} \leq 3276.6 \text{ MHz}$ where F_{downlink} is the downlink frequency in MHz

5 Transmitter Characteristics

5.1 General

Transmitting performance test of the UE is implemented during communicating with the SS via air interface. The procedure is using normal call protocol until the UE is communicating on traffic channel basically. On the traffic channel, the UE provides special function for testing that is called Logical Test Interface and the UE is tested using this function. (Refer to [4] TS 34.109).

Transmitting or receiving bit/symbol rate for test channel is shown in Table 5.1.

Table 5.1: Bit / Symbol rate for Test Channel

Type of User Information	User bit rate	DL DPCH symbol rate	UL DPCH bit rate	Remarks
12.2 kbps reference measurement channel	12.2 kbps	30 ksp/s	60 kbps	Standard Test

Unless detailed the transmitter characteristic are specified at the antenna connector of the UE. For UE with integral antenna only, a reference antenna with a gain of 0 dBi is assumed. Transmitter characteristics for UE(s) with multiple antennas/antenna connectors are FFS.

The UE antenna performance has a significant impact on system performance, and minimum requirements on the antenna efficiency are therefore intended to be included in future versions of this specification. It is recognised that different requirements and test methods are likely to be required for the different types of UE.

All the parameters in clause 5 are defined using the UL reference measurement channel (12.2 kbps) specified in subclause C.2.1 and unless stated otherwise, with the UL power control ON.

The common RF test conditions of Tx Characteristics are defined in Annex E.3.1, and each test conditions in this clause (clause 5) should refer Annex E.3.1. Individual test conditions are defined in the paragraph of each test.

5.2 Maximum Output Power

5.2.1 Definition and applicability

The maximum output power and its tolerance are defined according to the Power Class of the UE.

The maximum output power refers to the measure power when averaged over the transmit slot at the maximum power control setting.

The requirements and this test apply to all types of UTRA for the FDD UE.

5.2.2 Minimum Requirements

The UE maximum output power shall be within the shown value in Table 5.2.1 even for the multi-code transmission mode.

Table 5.2.1: Maximum Output Power

Power Class	Maximum output power	Tolerance
1	+33 dBm	+1/-3 dB
2	+27 dBm	+1/-3 dB
3	+24 dBm	+1/-3 dB
4	+21 dBm	± 2 dB

The normative reference for this requirement is [1] TS 25.101 subclause 6.2.1.

5.2.3 Test purpose

To verify that the error of the UE maximum output power does not exceed the prescribed tolerance in Table 5.2.1.

An excess maximum output power has the possibility to interfere to other channels or other systems. A small maximum output power decreases the coverage area.

5.2.4 Method of test

5.2.4.1 Initial conditions

- 1) Connect the SS to the UE antenna connector as shown in Figure A.1.
- 2) A call is set up according to the Generic call setup procedure.
- 3) Enter the UE into loopback test mode and start the loopback test.

See [3] TS 34.108 and [4] TS 34.109 for details regarding generic call setup procedure and loopback test.

5.2.4.2 Procedure

- 1) Set and send continuously Up power control commands to the UE.
- 2) Measure the output power of the UE by Tester. The output power shall be averaged over the transmit one timeslot.

5.2.5 Test requirements

The error of measured output power, derived in step 2), shall not exceed the prescribed tolerance in Table 5.2.2.

Table 5.2.2: Maximum Output Power

Power Class	Maximum output power	Tolerance
1	+33 dBm	+1.7/-3.7 dB
2	+27 dBm	+1.7/-3.7 dB
3	+24 dBm	+1.7/-3.7 dB
4	+21 dBm	± 2.7 dB

NOTE: If the above Test Requirement differs from the Minimum Requirement then the Test Tolerance applied for this test is non-zero. The Test Tolerance for this test is defined in Annex F.2 and the explanation of how the Minimum Requirement has been relaxed by the Test Tolerance is given in Annex F.4.

5.3 Frequency Error

5.3.1 Definition and applicability

The frequency error is the difference between the RF modulated carrier frequency transmitted from the UE with AFC ON and assigned frequency. The UE transmitter tracks to the RF carrier frequency received from the Node B. These signals will have an apparent error due to Node B frequency error and Doppler shift. In the later case, signals from the Node B must be averaged over sufficient time that errors due to noise or interference are allowed for within the above ± 0.1 PPM figure.

The UE shall use the same frequency source for both RF frequency generation and the chip clock.

The requirements and this test apply to all types of UTRA for the FDD UE.

5.3.2 Minimum Requirements

The UE modulated carrier frequency shall be accurate to within ± 0.1 ppm compared to the carrier frequency received from the Node B.

The normative reference for this requirement is [1] TS 25.101 subclause 6.3.

5.3.3 Test purpose

To verify that the UE carrier frequency error does not exceed ± 0.1 ppm.

An excess error of the carrier frequency increases the transmission errors in the up link own channel.

This test verifies the ability of receiver to derive correct frequency information for transmitter.

5.3.4 Method of test

5.3.4.1 Initial conditions

- 1) Connect the SS to the UE antenna connector as shown in Figure A.1.
- 2) A call is set up according to the Generic call setup procedure, and RF parameters (DPCH_Ec and \hat{I}_{or}) are set up according to Table 5.3. The relative power level of other downlink physical channels to the DPCH_Ec are set up according to Annex E.3.1.
- 3) Enter the UE into loopback test mode and start the loopback test.

See [3] TS 34.108 and [4] TS 34.109 for details regarding generic call setup procedure and loopback test.

Table 5.3: Test parameters for Frequency Error

Parameter	Level / Status	Unit
DPCH_Ec	-117	dBm / 3.84 MHz
\hat{I}_{or}	-106.7	dBm / 3.84 MHz

5.3.4.2 Procedure

- 1) Set and send continuously Up power control commands to the UE until the UE output power shall be maximum level.
- 2) Measure the frequency error delta f, at the UE antenna connector by Tester using Global In-Channel-Tx-test (Annex B). Since counter method leads an incorrect result, EVM method shall be used.

5.3.5 Test Requirements

For all measured bursts, the frequency error, derived in step 2), shall not exceed $\pm(0.1 \text{ ppm} + 10 \text{ Hz})$.

NOTE: If the above Test Requirement differs from the Minimum Requirement then the Test Tolerance applied for this test is non-zero. The Test Tolerance for this test is defined in Annex F.2 and the explanation of how the Minimum Requirement has been relaxed by the Test Tolerance is given in Annex F.4.

5.4 Output Power Dynamics in the Uplink

Power control is used to limit the interference level.

5.4.1 Open Loop Power Control in the Uplink

5.4.1.1 Definition and applicability

Open loop power control in the uplink is the ability of the UE transmitter to set its output power to a specific value. This function is used for PRACH transmission and based on the information from Node B using BCCH and the downlink received signal power level of the CPICH. The information from Node B includes transmission power of CPICH and uplink interference power level.

The requirements and this test apply to all types of UTRA for the FDD UE.

5.4.1.2 Conformance requirements

The UE open loop power is defined as the average power in a timeslot or ON power duration, whichever is available, and they are measured with a filter that has a Root-Raised Cosine (RRC) filter response with a roll off $\alpha = 0.22$ and a bandwidth equal to the chip rate.

The UE open loop power control tolerance is given in Table 5.4.1.1.

Table 5.4.1.1: Open loop power control tolerance

Normal conditions	$\pm 9 \text{ dB}$
Extreme conditions	$\pm 12 \text{ dB}$

The reference for this requirement is [1] TS 25.101 subclause 6.4.1.

5.4.1.3 Test purpose

The power of the received signal and the BCCH information control the power of the transmitted signal with the target to transmit at lowest power acceptable for proper communication.

The test stresses the ability of the receiver to measure the received power correctly over the receiver dynamic range.

The test purpose is to verify that the UE open loop power control tolerance does not exceed the described value shown in Table 5.4.1.1.

An excess error of the open loop power control decreases the system capacity.

5.4.1.4 Method of test

5.4.1.4.1 Initial conditions

- 1) Connect the SS to the UE antenna connector as shown in Figure A.1.
- 2) A call is set up according to the Generic call setup procedure, and \hat{I}_{or} is set up according to Table 5.4.1.2. The relative power level of downlink physical channels to I_{or} are set up according to Annex E.2.1. The RACH procedure within the call setup is used for the test.

See [3] TS 34.108 for details regarding generic call setup procedure.

Table 5.4.1.2: Test parameters for Open Loop Power Control (UE)

Parameter	Level / Status	Unit
\hat{I}_{or}	See Table 5.4.1.3	dBm / 3.84 MHz

Table 5.4.1.3: Test parameters for Open Loop Power Control (SS)

Parameter	RX Upper dynamic end	RX-middle	RX-Sensitivity level
\hat{I}_{or} ³⁾	-25.0 dBm / 3.84 MHz	-65.7 dBm / 3.84 MHz	-106.7 dBm / 3.84 MHz
CPICH_RSCP ^{3),4)}	-28.3 dBm	-69 dBm	-110 dBm
Primary CPICH DL TX power	+19 dBm	+28 dBm	+19 dBm
Simulated path loss = Primary CPICH DL TX power – CPICH_RSCP	+47.3 dBm	+97 dB	+129 dB
UL interference	-75 dBm	-101 dBm	-110 dBm
Constant Value	-10 dB	-10 dB	-10 dB
Expected nominal UE TX power ⁵⁾	-37.7dBm	-14dBm	+9 dBm ²⁾

NOTE 1: While the SS transmit power shall cover the receiver input dynamic range, the logical parameters: Primary CPICH DL TX power, UL interference, Constant Value are chosen to achieve a UE TX power, located within the TX output power dynamic range of a class 4 UE.

NOTE 2: Nominal TX output power 9 dBm allows to check the open loop power algorithm within the entire tolerance range (9 dBm \pm 12 dB; 9 dBm + 12 dB = 21 dBm = max power class 4).

NOTE 3: The power level of S-CCPCH should be defined because S-CCPCH is transmitted during Preamble RACH transmission period. The power level of S-CCPCH is temporarily set to -10.3dB relative to \hat{I}_{or} . However, it is necessary to check whether the above S-CCPCH level is enough to establish a connection with the reference measurement channels.

NOTE 4: The purpose of this parameter is to calculate the Expected nominal UE TX power.

NOTE 5: The Expected nominal UE TX power is calculated by using the equation in the clause 8.5.9 Open Loop Power Control of [8]TS25.331.

5.4.1.4.2 Procedure

- 1) Set the TX output level of the SS to obtain \hat{I}_{or} at the UE antenna connector. \hat{I}_{or} shall be according to Table 5.4.1.3 (-25 dBm / 3.84 MHz).
- 2) Measure the first RACH preamble output power of the UE according to Annex B.
- 3) Repeat the above measurement for all SS levels in Table 5.4.1.3.

5.4.1.5 Test requirements

The deviation with respect to the Expected nominal UE TX power (Table 5.4.1.3), derived in step 2), shall not exceed the prescribed tolerance in Table 5.4.1.1.

5.4.2 Inner Loop Power Control in the Uplink

5.4.2.1 Definition and applicability

Inner loop power control in the uplink is the ability of the UE transmitter to adjust its output power in accordance with one or more TPC commands received in the downlink.

The power control step is the change in the UE transmitter output power in response to a single TPC command, TPC_cmd, derived at the UE.

This clause does not cover all the requirements of compressed mode or soft handover.

The requirements and this test apply to all types of UTRA for the FDD UE.

5.4.2.2 Conformance requirements

The UE transmitter shall have the capability of changing the output power with a step size of 1, 2 and 3 dB according to the value of Δ_{TPC} or $\Delta_{\text{RP-TPC}}$, in the slot immediately after the TPC_cmd can be derived.

- a) The transmitter output power step due to inner loop power control shall be within the range shown in Table 5.4.2.1. The Maximum power threshold is defined as the lowest permissible maximum output power for the UE power class, as defined in Table 5.2.1. The Minimum power threshold is defined as -50 dBm.
- b) When the transmitter output power is between the Minimum and Maximum power thresholds, the transmitter average output power step due to inner loop power control shall be within the range shown in Table 5.4.2.2. Here a TPC_cmd group is a set of TPC_cmd values derived from a corresponding sequence of TPC commands of the same duration.

NOTE: 3dB inner loop power control steps are only used in compressed mode.

The inner loop power step is defined as the relative power difference between the average power of the original (reference) timeslot and the average power of the target timeslot, not including the transient duration. The transient duration is from $25\mu\text{s}$ before the slot boundary to $25\mu\text{s}$ after the slot boundary. The power is measured with a filter that has a Root-Raised Cosine (RRC) filter response with a roll off $\alpha = 0.22$ and a bandwidth equal to the chip rate.

Table 5.4.2.1: Transmitter power control tolerance

TPC_cmd	Transmitter power control range (all units are in dB)					
	1 dB step size		2 dB step size		3 dB step size	
	Lower	Upper	Lower	Upper	Lower	Upper
+ 1	+0.5	+1.5	+1	+3	+1.5	+4.5
0	-0.5	+0.5	-0.5	+0.5	-0.5	+0.5
- 1	-0.5	-1.5	-1	-3	-1.5	-4.5
+ 1 at or above max power threshold	-0.5	+1.5	-0.5	+3	-0.5	+4.5
- 1 at or below min power threshold	+0.5	-1.5	+0.5	-3	+0.5	-4.5

NOTE: The requirements for TPC_cmd = +1 at or above max power threshold and for TPC_cmd = -1 at or below min power threshold are included to avoid ambiguity in the required test behaviour. These requirements are not explicitly included in [1] but are consistent with [1] and [5].

Table 5.4.2.2: Transmitter average power control tolerance

TPC_cmd group	Transmitter power control range after 10 equal TPC_cmd group (all units are in dB)				Transmitter power control range after 7 equal TPC_cmd groups (all units are in dB)	
	1 dB step size		2 dB step size		3 dB step size	
	Lower	Upper	Lower	Upper	Lower	Upper
+ 1	+8	+12	+16	+24	+16	+26
0	-1	+1	-1	+1	-1	+1
- 1	-8	-12	-16	-24	-16	-26
0,0,0,0,+1	+6	+14	N/A	N/A	N/A	N/A
0,0,0,0,-1	-6	-14	N/A	N/A	N/A	N/A

The reference for this requirement is [1] TS 25.101 subclause 6.4.2.1.1.

The requirements for the derivation of TPC_cmd are detailed in TS 25.214 subclauses 5.1.2.2.2 and 5.1.2.2.3.

5.4.2.3 Test purpose

- To verify that the UE inner loop power control size and response is meet to the described value shown in subclause 5.4.2.2.
- To verify that TPC_cmd is correctly derived from received TPC commands.

An excess error of the inner loop power control decreases the system capacity.

5.4.2.4 Method of test

5.4.2.4.1 Initial conditions

- 1) Connect the SS to the UE antenna connector as shown in Figure A.1.
- 2) A call is set up according to the Generic call setup procedure. The Uplink DPCH Power Control Info shall specify the Power Control Algorithm as algorithm 2 for interpreting TPC commands.
- 3) Enter the UE into loopback test mode and start the loopback test.

See [3] TS 34.108 and [4] TS 34.109 for details regarding generic call setup procedure and loopback test.

5.4.2.4.2

Procedure

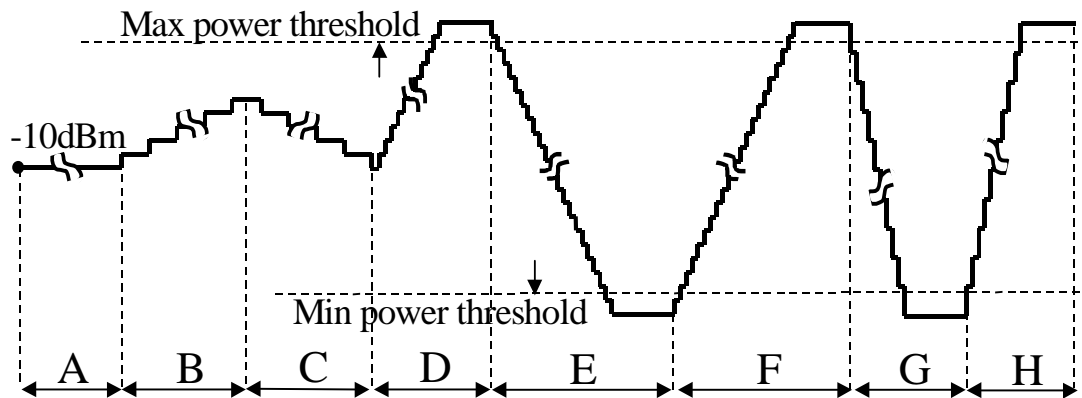

Figure 5.4.2.4 Inner Loop Power Control Test Steps

- 1) Before proceeding with paragraph (2) (Step A) below, set the output power of the UE, measured at the UE antenna connector, to be in the range -10 ± 9 dBm. This may be achieved by setting the downlink signal (\hat{I}_{or}) to yield an appropriate open loop output power and/or by generating suitable downlink TPC commands from the SS.
- 2) Step A: Transmit a sequence of at least 30 and no more than 60 TPC commands, which shall commence at a frame boundary and last for a whole number of frames, and which shall contain:
 - no sets of 5 consecutive “0” or “1” commands which commence in the 1st, 6th or 11th slots of a frame;
 - at least one set of 5 consecutive “0” commands which does not commence in the 1st, 6th or 11th slots of a frame;
 - at least one set of 5 consecutive “1” commands which does not commence in the 1st, 6th or 11th slots of a frame.

The following is an example of a suitable sequence of TPC commands:

```
1000001010101011111010000010101010111101000001010101011110
```

- 3) Step B: Transmit a sequence of 50 TPC commands with the value 1.
- 4) Step C: Transmit a sequence of 50 TPC commands with the value 0.
- 5) Step D: Reconfigure the uplink channel to set the Power Control Algorithm to algorithm 1, and the TPC step size to 1 dB. When the reconfiguration is complete, transmit a sequence of TPC commands with the value 1 until the UE output power is above the maximum power threshold.
- 6) Step E: Transmit a sequence of 150¹ TPC commands with the value 0.
- 7) Step F: Transmit a sequence of 150¹ TPC commands with the value 1.

- 8) Step G: Reconfigure the uplink channel to set the TPC step size to 2 dB (with the Power Control Algorithm remaining as algorithm 1). When the reconfiguration is complete, transmit a sequence of TPC commands with the value 1 until the UE output power is above the maximum power threshold. Transmit a sequence of 75¹ TPC commands with the value 0.
- 9) Step H: Transmit a sequence of 75¹ TPC commands with the value 1.
- 10) During steps A to H the mean output power of every slot shall be measured, with the following exceptions:
- In steps D and F, measurement of the output power is not required in slots after the 10th slot after the mean output power has exceeded the maximum power threshold;
 - In steps E and G, measurement of the output power is not required in slots after the 10th slot after the mean output power has fallen below the minimum power threshold.

The transient periods of 25µs before each slot boundary and 25µs after each slot boundary shall not be included in the power measurements.

¹ NOTE: These numbers of TPC commands are given as examples. The actual number of TPC commands transmitted in these steps shall be at least 10 more than the number required to ensure that the UE reaches the relevant maximum or minimum power threshold in each step, as shown in Figure 5.4.2.4.

5.4.2.5 Test requirements

- a) During Step A, the difference in mean output power between adjacent slots shall be within the prescribed range for a TPC_cmd of 0, as given in Table 5.4.2.1.
- b) During Step A, the change in mean output power over 10 consecutive slots shall be within the prescribed range for a TPC_cmd group of 0, as given in Table 5.4.2.2.
- c) During Step B, the difference in mean output power between adjacent slots shall be within the prescribed range given in Table 5.4.2.1, given that every 5th TPC_cmd should have the value + 1, with a step size of 1 dB, and all other TPC_cmd should have the value 0.
- d) During Step B, the change in mean output power over 50 consecutive slots shall be within the prescribed range for a TPC_cmd group of {0,0,0,0,+1}, as given in Table 5.4.2.2.
- e) During Step C, the difference in mean output power between adjacent slots shall be within the prescribed range given in Table 5.4.2.1, given that every 5th TPC_cmd should have the value - 1, with a step size of 1 dB, and all other TPC_cmd should have the value 0.
- f) During Step C, the change in mean output power over 50 consecutive slots shall be within the prescribed range for a TPC_cmd group of {0,0,0,0,-1}, as given in Table 5.4.2.2.
- g) During Step E, the difference in mean output power between adjacent slots shall be within the prescribed range given in Table 5.4.2.1 for a TPC_cmd of - 1 and step size of 1 dB, until the output power reaches (Minimum power threshold + 0.5 dB). When the output power is between the values of (Minimum power threshold + 0.5 dB) and (Minimum power threshold), the difference in mean output power between adjacent slots shall be at least sufficient to decrease the output power to the Minimum power threshold, but shall not exceed - 1.5 dB. Once the output power is at or below the Minimum power threshold, the relevant condition in Table 5.4.2.1 shall be met.
- h) During Step E, the change in mean output power over 10 consecutive slots shall be within the prescribed range for a TPC_cmd group of - 1, and step size of 1 dB as given in Table 5.4.2.2, until the output power reaches (Minimum power threshold + 0,5 dB).

- i) During Step F, the difference in mean output power between adjacent slots shall be within the prescribed range given in Table 5.4.2.1 for a TPC_cmd of + 1 and step size of 1 dB, until the output power reaches (Maximum power threshold – 0,5 dB). When the output power is between the values of (Maximum power threshold – 0,5 dB) and (Maximum power threshold), the difference in mean output power between adjacent slots shall be at least sufficient to increase the output power to the Maximum power threshold, but shall not exceed + 1,5 dB. Once the output power is at or above the Maximum power threshold, the relevant condition in Table 5.4.2.1 shall be met.
- j) During Step F, the change in mean output power over 10 consecutive slots shall be within the prescribed range for a TPC_cmd group of + 1, and step size of 1 dB as given in Table 5.4.2.2, until the output power reaches (Maximum power threshold – 0,5 dB).
- k) During Step G, the difference in mean output power between adjacent slots shall be within the prescribed range given in Table 5.4.2.1 for a TPC_cmd of – 1 and step size of 2 dB, until the output power reaches (Minimum power threshold + 1 dB). When the output power is between the values of (Minimum power threshold + 1 dB) and (Minimum power threshold), the difference in mean output power between adjacent slots shall be at least sufficient to decrease the output power to the Minimum power threshold, but shall not exceed – 3 dB. Once the output power is at or below the Minimum power threshold, the relevant condition in Table 5.4.2.1 shall be met.
- l) During Step G, the change in mean output power over 10 consecutive slots shall be within the prescribed range for a TPC_cmd group of – 1, and step size of 2 dB as given in Table 5.4.2.2, until the output power reaches (Minimum power threshold +1 dB).
- m) During Step H, the difference in mean output power between adjacent slots shall be within the prescribed range given in Table 5.4.2.1 for a TPC_cmd of + 1 and step size of 2 dB, until the output power reaches (Maximum power threshold –1 dB). When the output power is between the values of (Maximum power threshold –1 dB) and (Maximum power threshold), the difference in mean output power between adjacent slots shall be at least sufficient to increase the output power to the Maximum power threshold, but shall not exceed + 3 dB. Once the output power is at or above the Maximum power threshold, the relevant condition in Table 5.4.2.1 shall be met.
- n) During Step H, the change in mean output power over 10 consecutive slots shall be within the prescribed range for a TPC_cmd group of + 1, and step size of 2 dB as given in Table 5.4.2.2, until the output power reaches (Maximum power threshold – 1 dB).

5.4.3 Minimum Output Power

5.4.3.1 Definition and applicability

The minimum controlled output power of the UE is when the power control setting is set to a minimum value. This is when both the inner loop and open loop power control indicate a minimum transmit output power is required.

The requirements and this test apply to all types of UTRA for the FDD UE.

5.4.3.2 Minimum Requirements

The minimum transmit power is defined as an averaged power in a time slot measured with a filter that has a Root-Raised Cosine (RRC) filter response with a roll off $\alpha = 0.22$ and a bandwidth equal to the chip rate. The minimum transmit power shall be better than –50 dBm.

The normative reference for this requirement is [1] TS 25.101 subclause 6.4.3.1.

5.4.3.3 Test purpose

To verify that the UE minimum transmit power is below –50 dBm.

An excess minimum output power increases the interference to other channels, and decreases the system capacity.

5.4.3.4 Method of test

5.4.3.4.1 Initial conditions

- 1) Connect the SS to the UE antenna connector as shown in Figure A.1.
- 2) A call is set up according to the Generic call setup procedure.
- 3) Enter the UE into loopback test mode and start the loopback test.

See [3] TS 34.108 and [4] TS 34.109 for details regarding generic call setup procedure and loopback test.

5.4.3.4.2 Procedure

- 1) Set and send continuously Down power control commands to the UE.
- 2) Measure the output power of the UE by Tester.

5.4.3.5 Test requirements

The measured output power, derived in step 2), shall be below -49 dBm.

NOTE: If the above Test Requirement differs from the Minimum Requirement then the Test Tolerance applied for this test is non-zero. The Test Tolerance for this test is defined in Annex F.2 and the explanation of how the Minimum Requirement has been relaxed by the Test Tolerance is given in Annex F.4.

5.4.4 Out-of-synchronisation handling of output power

5.4.4.1 Definition and applicability

The UE shall monitor the DPCCH quality in order to detect a loss of the signal on Layer 1, as specified in [5] TS 25.214. The thresholds Q_{out} and Q_{in} specify at what DPCCH quality levels the UE shall shut its power off and when it shall turn its power on respectively. The thresholds are not defined explicitly, but are defined by the conditions under which the UE shall shut its transmitter off and turn it on, as stated in this subclause.

5.4.4.2 Minimum Requirements

The parameters in Table 5.4.4.1 are defined using the DL reference measurement channel (12.2 kbps) specified in Annex C.3.1 and with static propagation conditions.

Table 5.4.4.1: DCH parameters for test of Out-of-synch handling

Parameter	Value	Unit
\hat{I}_{or}/I_{oc}	-1	dB
I_{oc}	-60	dBm / 3.84 MHz
$\frac{DPDCH_E_c}{I_{or}}$	See Figure 5.4.4.1: Before point A -16.6 After point A Not defined ¹⁾	dB
$\frac{DPCCH_E_c}{I_{or}}$	See Table 5.4.4.2	dB
Information Data Rate	12.2	kbps
TFCI	on	-

Table 5.4.4.2: Minimum Requirements for DPCCH_Ec/Ior levels

Section from figure 5.4.4.1	DPCCH_Ec/Ior	Unit
Before A	-16.6	dB
A to B	-22.0	dB
B to D	-28.0	dB
D to E	-24.0	dB
After E	-18.0	dB

The conditions for when the UE shall shut its transmitter off and when it shall turn it on are defined by the parameters in Table 5.4.4.1 and Table 5.4.4.2.

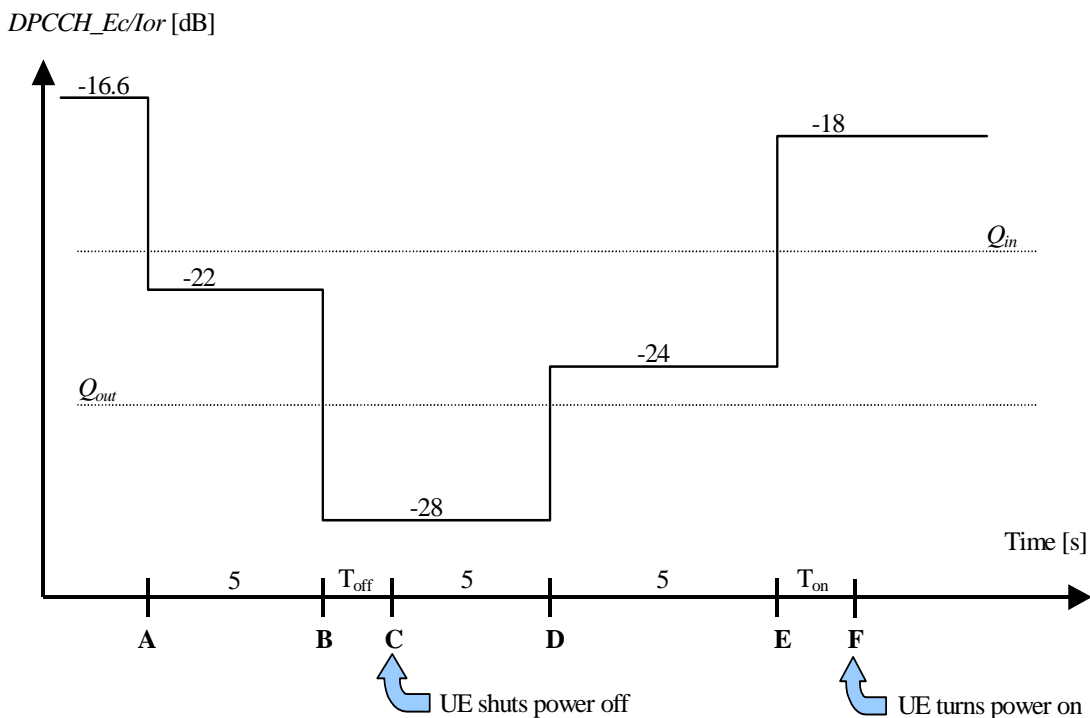

Figure 5.4.4.1: Conditions for out-of-synch handling in the UE. The indicated thresholds Q_{out} and Q_{in} are only informative.

The requirements for the UE are that

1. The UE shall not shut its transmitter off before point B.
2. The UE shall shut its transmitter off before point C, which is $T_{off} = 200$ ms after point B.
3. The UE shall not turn its transmitter on between points C and E.
4. The UE shall turn its transmitter on before point F, which is $T_{on} = 200$ ms after point E.

The normative reference for this requirement is [1] TS 25.101 subclause 6.4.4.1.

5.4.4.3 Test purpose

To verify that the UE monitors the DPCCH quality and turns its transmitter on or off according to DPCCH level diagram specified in Figure 5.4.4.1.

NOTE 1: DPCCH_Ec/I_{or} after point A is not defined in Table 5.4.4.1. However it is assumed that DPCCH and DPCCH power level are same on DL 12.2kbps reference measurement channel for testing. (PO1, PO2, and PO3 are zero.)

5.4.4.4 Method of test

5.4.4.4.1 Initial conditions

- 1) Connect the SS to the UE antenna connector as shown in Figure A.1.
- 2) A call is set up according to the Generic call setup procedure, and DCH parameters are set up according to Table 5.4.4.1 with DPCCH_Ec/Ior ratio level at -16.6 dB. The other RF parameters are set up according to Annex E.3.1.
- 3) Enter the UE into loopback test mode and start the loopback test.

See [3] TS 34.108 and [4] TS 34.109 for details regarding generic call setup procedure and loopback test.

5.4.4.4.2 Procedure

- 1) The SS sends continuously Up power control commands to the UE until the UE transmitter power reach maximum level.
- 2) The SS controls the DPCCH_Ec/Ior ratio level according to section 'A to B' as defined in Table 5.4.4.3. The SS monitors the UE transmitted power for 5 seconds and verifies that the UE transmitter is not switched off during this time.
- 3) The SS controls the DPCCH_Ec/Ior ratio level according to section 'B to D' as defined in Table 5.4.4.3. The SS waits 200 ms and then verifies that the UE transmitter has been switched off.
- 4) The SS monitors the UE transmitted power for 5 seconds and verifies that the UE transmitter is not switched on during this time.
- 5) The SS controls the DPCCH_Ec/Ior ratio level according to section 'E to F' as defined in Table 5.4.4.3. The SS monitors the UE transmitted power for 5 seconds and verifies that the UE transmitter is not switched on during this time.
- 6) The SS controls the DPCCH_Ec/Ior ratio level according to section 'After F' as defined in Table 5.4.4.3. The SS waits 200 ms and then verifies that the UE transmitter has been switched on.

5.4.4.5 Test requirements

Table 5.4.4.3: Test Requirements for DPCCH_Ec/Ior levels

Section from figure 5.4.4.1	DPCCH_Ec/Ior	Unit
Before A	-16.6	dB
A to B	-[21.7]	dB
B to D	-[28.3]	dB
D to E	-[24.3]	dB
After E	-[17.7]	dB

To pass the test, steps 1 through 6 of the procedure in 5.4.4.4.2 must be fulfilled.

The UE transmitter off criterion and its tolerances is defined in subclause 5.5.1 (Transmit off power)

The UE transmitter on criterion and its tolerances is defined in subclause 5.4.3 (Minimum Output Power). The UE transmitter is considered to be on if the UE transmitted power is higher than minimum output power.

NOTE: If the above Test Requirement differs from the Minimum Requirement then the Test Tolerance applied for this test is non-zero. The Test Tolerance for this test is defined in Annex F.2 and the explanation of how the Test Requirement has been relaxed by the Test Tolerance is given in Annex F.4.

5.5 Transmit ON/OFF Power

5.5.1 Transmit OFF Power

5.5.1.1 Definition and applicability

The transmit OFF power state is when the UE does not transmit except during uplink compressed mode. This parameter is defined as the maximum output transmit power within the channel bandwidth when the transmitter is OFF.

The requirements and this test apply to all types of UTRA for the FDD UE.

5.5.1.2 Minimum Requirements

The transmit OFF power is defined as an averaged power at least in a timeslot duration, excluding any transient periods, measured with a filter that has a Root-Raised Cosine (RRC) filter response with a roll off $\alpha = 0.22$ and a bandwidth equal to the chip rate. The requirement for the transmit OFF power shall be better than -56 dBm.

The normative reference for this requirement is [1] TS 25.101 subclause 6.5.1.1.

5.5.1.3 Test purpose

To verify that the UE transmit OFF power is below -56 dBm.

An excess transmit OFF power increases the interference to other channels, and decreases the system capacity.

5.5.1.4 Method of test

This test is also covered by subclause 5.5.2 Transmit ON/OFF Time mask.

5.5.1.4.1 Initial conditions

- 1) Connect the SS to the UE antenna connector as shown in Figure A.1.
- 2) A call is set up according to the Generic call setup procedure.
- 3) Enter the UE into loopback test mode and start the loopback test.

See [3] TS 34.108 and [4] TS 34.109 for details regarding generic call setup procedure and loopback test.

5.5.1.4.2 Procedure

- 1) Send release message to the UE to stop transmitting.
- 2) Measure the leakage power within the transmission band from the UE by the Tester.

5.5.1.5 Test requirements

The measured leakage power, derived in step 2), shall be below -55 dBm.

NOTE: If the above Test Requirement differs from the Minimum Requirement then the Test Tolerance applied for this test is non-zero. The Test Tolerance for this test is defined in Annex F.2 and the explanation of how the Minimum Requirement has been relaxed by the Test Tolerance is given in Annex F.4.

5.5.2 Transmit ON/OFF Time mask

5.5.2.1 Definition and applicability

The time mask for transmit ON/OFF defines the ramping time allowed for the UE between transmit OFF power and transmit ON power. Possible ON/OFF scenarios are PRACH, CPCH or uplink compressed mode.

The requirements and this test apply to all types of UTRA for the FDD UE.

5.5.2.2 Conformance requirements

The transmit power levels versus time shall meet the mask specified in Figure 5.5.1 for PRACH preambles, and the mask in Figure 5.5.2 for all other cases. The signal is measured with a filter that has a Root-Raised Cosine (RRC) filter response with a roll off $\alpha = 0.22$ and a bandwidth equal to the chip rate.

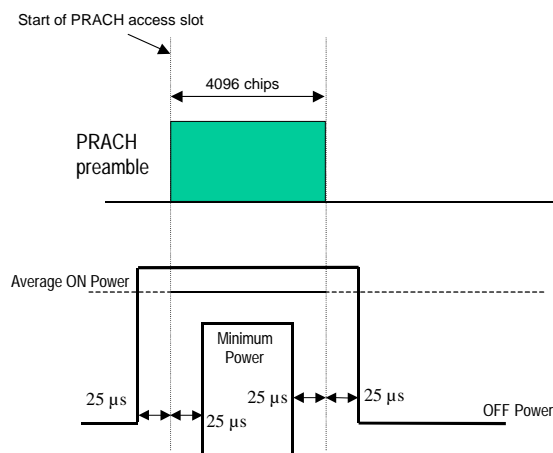

Figure 5.5.1: Transmit ON/OFF template for PRACH preambles

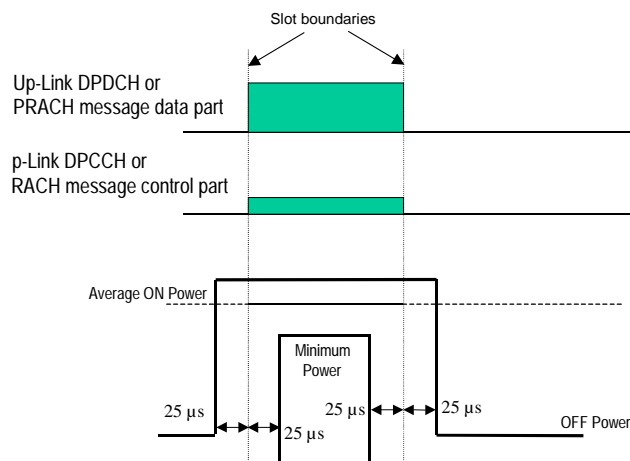

Figure 5.5.2: Transmit ON/OFF template for all other On/Off cases

OFF Power is defined in 5.5.1.

ON power is defined as either case as follows. The specification depends on each possible case.

- First preamble of PRACH: Open loop accuracy (Table 5.4.1.1).
- During preamble ramping of the RACH and between final RACH preamble and RACH message part: Accuracy depending on size of the required power difference (Table 5.5.2.1).
- After transmission gaps in compressed mode: Accuracy as in Table 5.7.1.

- Power step to Maximum Power: Maximum power accuracy (Table 5.2.1).

Table 5.5.2.1: Transmitter power difference tolerance for RACH preamble ramping, and between final RACH preamble and RACH message part

Power difference size ΔP [dB]	Transmitter power difference tolerance [dB]
0	+/- 1 dB
1	+/- 1 dB
2	+/- 1.5 dB
3	+/- 2 dB
$4 \leq \Delta P \leq 10$	+/- 2.5 dB
$11 \leq \Delta P \leq 15$	+/- 3.5 dB
$16 \leq \Delta P \leq 20$	+/- 4.5 dB
$21 \leq \Delta P$	+/- 6.5 dB

The reference for this requirement is [1] TS 25.101 subclause 6.5.2.1.

This is tested using PRACH operation.

The minimum requirement for ON power is defined in subclause 5.4.1.2.

The minimum requirement for OFF power is defined in subclause 5.5.1.2.

Note: The main objective for this test case is to check the ramp-up/down power shape. A test case using the first preamble of PRACH is enough to cover the objective.

5.5.2.3 Test purpose

To verify that the UE transmit ON/OFF power levels versus time meets the described mask shown in Figure 5.5.1 and Figure 5.5.2.

An excess error of transmit ON/OFF response increases the interference to other channels, or increases transmission errors in the up link own channel.

5.5.2.4 Method of test

5.5.2.4.1 Initial conditions

- 1) Connect the SS to the UE antenna connector as shown in Figure A.1.
- 2) A call is set up according to the Generic call setup procedure, and \hat{I}_{or} are set up according to Table 5.5.2.2. The relative power level of downlink physical channels to I_{or} are set up according to Annex E.2.1.

The RACH procedure within the call setup is used for the test.

See [3] TS 34.108 for details regarding generic call setup procedure.

Table 5.5.2.2: Test parameters for Transmit ON/OFF Time mask (UE)

Parameter	Level / Status	Unit
\hat{I}_{or}	See Table 5.5.2.2	dBm / 3.84 MHz

Table 5.5.2.3: Test parameters for Transmit ON/OFF Time mask (SS)

Parameter	Power Class 1	Power Class 2	Power Class 3	Power Class 4	Unit
\hat{I}_{or} ¹⁾	-106.7	-106.7	-106.7	-106.7	dBm / 3.84 MHz
CPICH_RSCP ^{1),2)}	-110	-110	-110	-110	dBm
Primary CPICH DL TX power	+19	+19	+19	+19	dBm
Simulated path loss = Primary CPICH DL TX power – CPICH_RSCP	+129	+129	+129	+129	dB
UL interference	-86	-92	-95	-98	dBm
Constant Value	-10	-10	-10	-10	dB
Expected nominal UE TX power ³⁾	+33	+27	+24	+21	dBm

NOTE 1: The power level of S-CCPCH should be defined because S-CCPCH is transmitted during Preamble RACH transmission period. The power level of S-CCPCH is temporarily set to -10.3dB relative to \hat{I}_{or} . However, it is necessary to check whether the above S-CCPCH level is enough to establish a connection with the reference measurement channels.

NOTE 2: The purpose of this parameter is to calculate the Expected nominal UE TX power.

NOTE 3: The Expected nominal UE TX power is calculated by using the equation in the clause 8.5.9 Open Loop Power Control of [8] TS25.331.

5.5.2.4.2 Procedure

- 1) Set the TX output level of the SS to obtain \hat{I}_{or} at the UE antenna connector and select the test parameters of Table 5.5.2.3 according to the power class. \hat{I}_{or} shall be according to Table 5.5.2.3 (-106.7 dBm / 3.84 MHz).
- 2) Measure the first RACH preamble output power (ON power) of the UE. The measurements shall not include the transient periods.
- 3) Measure the OFF power immediately before and after the first RACH preamble (ON power). The measurements shall not include the transient periods.

5.5.2.5 Test requirements

The deviation with respect to the Expected nominal UE TX power (Table 5.5.2.3), derived in step 2), shall not exceed the prescribed upper tolerance in Table 5.2.1 (Subclause 5.2.2) and lower tolerance in Table 5.4.1.1. (Subclause 5.4.1.2).

The measured leakage power, derived in step 3), shall be below -56 dBm. (Subclause 5.5.1.2).

5.6 Change of TFC

5.6.1 Definition and applicability

A change of TFC (Transport Format Combination) in uplink means that the power in the uplink varies according to the change in data rate. DTX, where the DPCH is turned off, is a special case of variable data, which is used to minimise the interference between UE(s) by reducing the UE transmit power when voice, user or control information is not present.

The requirements and this test apply to all types of UTRA for the FDD UE.

5.6.2 Conformance requirements

A change of output power is required when the TFC, and thereby the data rate, is changed. The ratio of the amplitude between the DPDCH codes and the DPCCH code will vary. The power step due to a change in TFC shall be calculated in the UE so that the power transmitted on the DPCCH shall follow the inner loop power control. The step in total transmitted power (DPCCH + DPDCH) shall then be rounded to the closest integer dB value. A power step exactly half-way between two integer values shall be rounded to the closest integer of greater magnitude. The accuracy of the power step, given the step size is specified in Table 5.6.1. The power change due to a change in TFC is defined as the relative power difference between the average power of the original (reference) timeslot and the average power of the target timeslot, not including the transient duration. The transient duration is from 25µs before the slot boundary to 25µs after the slot boundary. The power is measured with a filter that has a Root-Raised Cosine (RRC) filter response with a roll off $\alpha = 0.22$ and a bandwidth equal to the chip rate.

Table 5.6.1: Transmitter power step tolerance

Power control step size (Up or down) ΔP [dB]	Transmitter power step tolerance
0	+/- 0.5 dB
1	+/- 0.5 dB
2	+/- 1.0 dB
3	+/- 1.5 dB
$4 \leq \Delta P \leq 10$	+/- 2.0 dB
$11 \leq \Delta P \leq 15$	+/- 3.0 dB
$16 \leq \Delta P \leq 20$	+/- 4.0 dB
$21 \leq \Delta P$	+/- 6.0 dB

Clause C.2.1 defines the UL reference measurement channels (12,2 kbps) for TX test and the power ratio between DPCCH and DPDCH as -5.46 dB. Therefore, only one power control step size is selected as minimum requirement from Table 5.6.1. The accuracy of the power step, given the step size is specified in Table 5.6.2.

Table 5.6.2: Transmitter power step tolerance for test

Quantized amplitude ratios β_c and β_d	Power control step size (Up or down) ΔP [dB]	Transmitter power step tolerance
$\beta_c = 0.5333, \beta_d = 1.0$	7	+/- 2 dB

The transmit power levels versus time shall meet the mask specified in Figure 5.6.1.

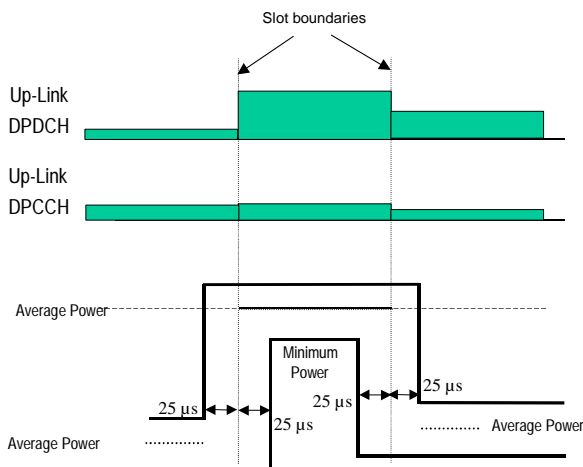

Figure 5.6.1: Transmit template during TFC change

The UL reference measurement channel (12.2 kbps) is a fixed rate channel. Therefore, DTX, where the DPDCH is turned off, is tested, as shown in Figure 5.6.2.

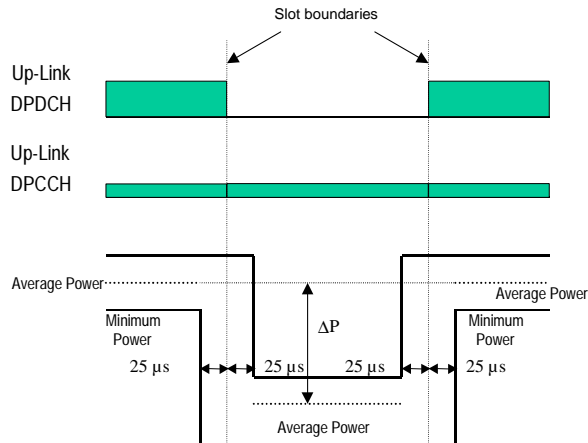

Figure 5.6.2: Transmit template during DTX

The reference for this requirement is [1] TS 25.101 subclause 6.5.3.1.

5.6.3 Test purpose

To verify that the tolerance of power control step size does not exceed the described value shown in Table 5.6.2.

To verify that the DTX ON/OFF power levels versus time meets the described mask shown in Figure 5.6.2.

5.6.4 Method of test

5.6.4.1 Initial conditions

- 1) Connect the SS to the UE antenna connector as shown in Figure A.1.
- 2) A call is set up according to the Generic call setup procedure. The Uplink DPCH Power Control Info shall specify the Power Control Algorithm as algorithm 2 for interpreting TPC commands.
- 3) Enter the UE into loopback test mode and start the loopback test.

See [3] TS 34.108 and [4] TS 34.109 for details regarding generic call setup procedure and loopback test.

5.6.4.2 Procedure

- 1) Set the attenuation in the downlink signal (\hat{I}_{Or}) to yield an open loop output power, measured at the UE antenna connector, of 0 dBm.
- 2) Send alternating “0” and “1” TPC commands in the downlink so as to satisfy the condition of obtaining $TPC_cmd = 0$.
- 3) Using the Tester, measure the average output power at the antenna connector of the UE in two cases, both DPDCH and DPCCH are ON and only DPCCH is ON. The measurements shall not include the transient periods.

5.6.5 Test requirements

The difference in mean output power between DPDCH ON and OFF, derived in step 3), shall not exceed the prescribed range in Table 5.6.2.

5.7 Power setting in uplink compressed mode

5.7.1 Definition and applicability

Compressed mode in uplink means that the power in uplink is changed.

The requirements and this test apply to all types of UTRA for the FDD UE.

5.7.2 Conformance requirements

A change of output power is required during uplink compressed frames since the transmission of data is performed in a shorter interval. The ratio of the amplitude between the DPDCH codes and the DPCCH code will also vary. The power step due to compressed mode shall be calculated in the UE so that the energy transmitted on the pilot bits during each transmitted slot shall follow the inner loop power control.

Thereby, the power during compressed mode, and immediately afterwards, shall be such that the power on the DPCCH follows the steps due to inner loop power control combined with additional steps of $10\log_{10}(N_{\text{pilot,prev}} / N_{\text{pilot,curr}})$ dB where $N_{\text{pilot,prev}}$ is the number of pilot bits in the previously transmitted slot, and $N_{\text{pilot,curr}}$ is the current number of pilot bits per slot.

The resulting step in total transmitted power (DPCCH + DPDCH) shall then be rounded to the closest integer dB value. A power step exactly half-way between two integer values shall be rounded to the closest integer of greatest magnitude. The accuracy of the power step, given the step size, is specified in Table 5.6.1 in subclause 5.6.2. The power step is defined as the relative power difference between the average power of the original (reference) timeslot and the average power of the target timeslot, when neither the original timeslot nor the reference timeslot are in a transmission gap. The transient duration is not included, and is from 25µs before the slot boundary to 25µs after the slot boundary. The relative power is measured with a filter that has a Root-Raised Cosine (RRC) filter response with a roll off $\alpha = 0.22$ and a bandwidth equal to the chip rate.

In addition to any power change due to the ratio $N_{\text{pilot,prev}} / N_{\text{pilot,curr}}$, the average power of the DPCCH in the first slot after a compressed mode transmission gap shall differ from the average power in the last slot before the transmission gap by an amount Δ_{RESUME} , where Δ_{RESUME} is calculated as described in subclause 5.1.2.3 of [5] TS 25.214.

The resulting difference in the total transmitted power (DPCCH + DPDCH) shall then be rounded to the closest integer dB value. A power difference exactly half-way between two integer values shall be rounded to the closest integer of greatest magnitude. The accuracy of the resulting difference in the total transmitted power (DPCCH + DPDCH) after a transmission gap of up to 14 slots shall be as specified in Table 5.7.1.

Table 5.7.1: Transmitter power difference tolerance after a transmission gap of up to 14 slots

Tolerance on required difference in total transmitter power after a transmission gap
+/- 3 dB

The power difference is defined as the relative power difference between the average power of the original (reference) timeslot before the transmission gap and the average power of the target timeslot after the transmission gap, not including the transient durations. The transient durations at the start and end of the transmission gaps are each from 25µs before the slot boundary to 25µs after the slot boundary. The relative power is measured with a filter that has a Root-Raised Cosine (RRC) filter response with a roll off $\alpha = 0.22$ and a bandwidth equal to the chip rate.

The transmit power levels versus time shall meet the mask specified in Figure 5.7.1.

The reference for this requirement is [1] TS 25.101 subclause 6.5.4.1.

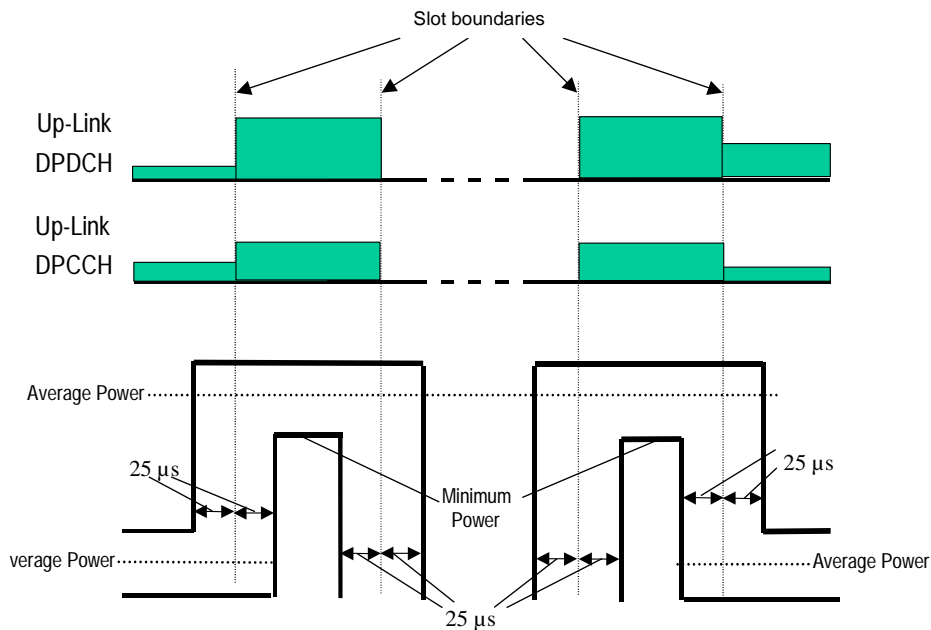

Figure 5.7.1: Transmit template during Compressed mode

The mean power in the transmission gaps, not including the transition periods, shall be less than -56 dBm. The reference for this requirement is [1] TS 25.101 subclause 6.5.1.1.

For RPL (Recovery Period Length) slots after the transmission gap, where RPL is the minimum out of the transmission gap length and 7 slots, the UE shall use the power control algorithm and step size specified by the signalled Recovery Period Power Control Mode (RPP), as detailed in TS 25.214 subclause 5.1.2.3.

When nominal 3 dB power control steps are used in the recovery period, the transmitter output power steps due to inner loop power control shall be within the range shown in Table 5.7.2, and the transmitter average output power step due to inner loop power control shall be within the range shown in Table 5.7.3, excluding any other power changes due, for example, to changes in spreading factor or number of pilot bits.

Table 5.7.2: Transmitter power control range for 3dB step size

TPC_cmd	Transmitter power control range for 3dB step size	
	Lower	Upper
+ 1	+1.5 dB	+4.5 dB
0	-0.5 dB	+0.5 dB
- 1	-1.5 dB	-4.5 dB

Table 5.7.3: Transmitter average power control range for 3dB step size

TPC_cmd group	Transmitter power control range after 7 equal TPC_cmd groups	
	Lower	Upper
+ 1	+16 dB	+26 dB
0	-1 dB	+1 dB
- 1	-16 dB	-26 dB

The reference for this requirement is [1] TS 25.101 subclause 6.4.2.1.1.

5.7.3 Test purpose

To verify that the changes in uplink transmit power in compressed mode are within the prescribed tolerances.

Excess error in transmit power setting in compressed mode increases the interference to other channels, or increases transmission errors in the uplink.

5.7.4 Method of test

5.7.4.1 Initial conditions

- 1) Connect the SS to the UE antenna connector as shown in Figure A.1.
- 2) A call is set up according to the Generic call setup procedure. The 12.2 kbps UL reference measurement channel is used, with gain factors $\beta_c = 0.5333$ and $\beta_d = 1.0$ in non-compressed frames. Slot formats 0, 0A and 0B are used on the uplink DPCCCH.
- 3) Enter the UE into loopback test mode and start the loopback test.

See [3] TS 34.108 and [4] TS 34.109 for details regarding generic call setup procedure and loopback test.

5.7.4.2 Procedure

NOTE: CFNs are given in this procedure for reference as examples only. A fixed offset may be applied to the CFNs.

- 1) Before proceeding with paragraph (4) below, set the output power of the UE, measured at the UE antenna connector, to be in the range -34 ± 9 dBm. This may be achieved by setting the downlink signal (\hat{I}) or to yield an appropriate open loop output power and/or by generating suitable downlink TPC commands from the SS.
- 2) Signal the uplink power control parameters to use Algorithm 1 and a step size of 2 dB.
- 3) Signal the set of compressed mode parameters shown in Table 5.7.5. This set of compressed mode parameters defines the compressed mode pattern which is used to test the implementation of 3dB output power steps and the implementation of a power change when resuming transmission after a compressed mode gap.

Table 5.7.5: Parameters for pattern A for compressed mode test

Parameter	Meaning	Value
TGPRC	Number of transmission gap patterns within the Transmission Gap Pattern Sequence	1
TGCFN	Connection Frame Number of the first frame of the first pattern within the Transmission Gap Pattern Sequence	0
TGSN	Slot number of the first transmission gap slot within the TGCFN	10
TGL1	Length of first transmission gap within the transmission gap pattern	10 slots
TGL2	Length of second transmission gap within the transmission gap pattern	5 slots
TGD	Duration between the starting slots of two consecutive transmission gaps within a transmission gap pattern	20 slots
TGPL1	Duration of transmission gap pattern 1	3 frames
TGPL2	Duration of transmission gap pattern 2	Omit
RPP	Recovery Period Power Control Mode	Mode 1
ITP	Initial Transmit Power Mode	Mode 1
UL/DL Mode	Defines whether only DL, only UL, or combined UL/DL compressed mode is used	UL/DL
Downlink Compressed Mode Method	Method for generating downlink compressed mode gap	SF/2
Uplink Compressed Mode Method	Method for generating uplink compressed mode gap	SF/2
Scrambling code change	Indicates whether the alternative scrambling code is used	No code change
Downlink frame type	Downlink compressed frame structure	A
DeltaSIR	Delta in DL SIR target value to be set in the UE during compressed frames	0
DeltaSIRafter	Delta in DL SIR target value to be set in the UE one frame after the compressed frames	0

The resulting compressed mode pattern is shown in Figure 5.7.2.

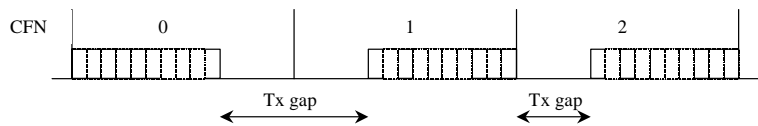

Figure 5.7.2: Pattern A for compressed mode test

- 4) Transmit TPC commands on the downlink as shown in Table 5.7.6:

Table 5.7.6: TPC commands transmitted in downlink

CFN	TPC commands in downlink
0	1111111111----
1	-----1111111100
2	-----0101010101

- 5) Measure the mean output power in the following slots, not including the 25µs transient periods at the start and end of each slot:

CFN 1: Slots # 5,6,7,8,9,10,11,12,14

CFN 2: Slot # 5

Also measure the mean output power in each transmission gap, not including the 25µs transient periods at the start and end of each transmission gap.

- 6) Re-start the test. Before proceeding with step (8) below, set the output power of the UE, measured at the UE antenna connector, to be in the range 3±9dBm. This may be achieved by, setting the downlink signal (\hat{I}_{or}) to yield an appropriate open loop output power and/or by generating suitable downlink TPC commands from the SS.
- 7) Repeat steps (2) and (3) above, with the exception that TGCFN = 3.
- 8) Transmit TPC commands on the downlink as shown in Table 5.7.7:

Table 5.7.7: TPC commands transmitted in downlink

CFN	TPC commands in downlink
3	0000000000-----
4	-----0000000011
5	-----1010101010

- 9) Measure the mean output power in the following slots, not including the 25µs transient periods at the start and end of each slot:

CFN 4: Slots # 5,6,7,8,9,10,11,12,14

CFN 5: Slot # 5

Also measure the mean output power in each transmission gap, not including the 25µs transient periods at the start and end of each transmission gap.

- 10) Re-start the test. Before proceeding with step (13) below, set the output power of the UE, measured at the UE antenna connector, to be in the range -10±9dBm. This may be achieved by setting the downlink signal (\hat{I}_{or}) to yield an appropriate open loop output power and/or by generating suitable downlink TPC commands from the SS.
- 11) Signal the uplink power control parameters to use Algorithm 1 and a step size of 1 dB.

12) Signal the set of compressed mode parameters shown in Table 5.7.8. This set of compressed mode parameters defines the compressed mode pattern which is used to test the implementation of power steps at the start and end of compressed frames, and the implementation of a zero power change when resuming transmission after a compressed mode gap.

Table 5.7.8: Parameters for pattern B for compressed mode test

Parameter	Meaning	Value
TGPRC	Number of transmission gap patterns within the Transmission Gap Pattern Sequence	1
TGCFN	Connection Frame Number of the first frame of the first pattern within the Transmission Gap Pattern Sequence	7
TGSN	Slot number of the first transmission gap slot within the TGCFN	8
TGL1	Length of first transmission gap within the transmission gap pattern	14 slots
TGL2	Length of second transmission gap within the transmission gap pattern	omit
TGD	Duration between the starting slots of two consecutive transmission gaps within a transmission gap pattern	0
TGPL1	Duration of transmission gap pattern 1	4 frames
TGPL2	Duration of transmission gap pattern 2	Omit
RPP	Recovery Period Power Control Mode	Mode 0
ITP	Initial Transmit Power Mode	Mode 0
UL/DL Mode	Defines whether only DL, only UL, or combined UL/DL compressed mode is used	UL/DL
Downlink Compressed Mode Method	Method for generating downlink compressed mode gap	SF/2
Uplink Compressed Mode Method	Method for generating uplink compressed mode gap	SF/2
Scrambling code change	Indicates whether the alternative scrambling code is used	No code change
Downlink frame type	Downlink compressed frame structure	A
DeltaSIR	Delta in DL SIR target value to be set in the UE during compressed frames	0
DeltaSIRafter	Delta in DL SIR target value to be set in the UE one frame after the compressed frames	0

The resulting compressed mode pattern is shown in Figure 5.7.3.

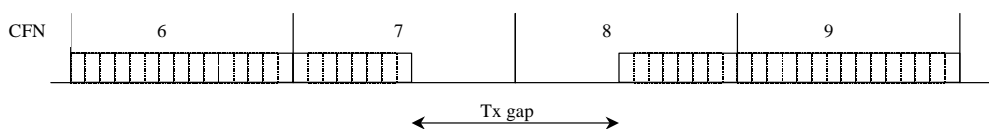

Figure 5.7.3: Pattern B for compressed mode test

13) Transmit TPC commands on the downlink as shown in Table 5.7.8:

Table 5.7.8: TPC commands transmitted in downlink

CFN	TPC commands in downlink
6	0000000000000111
7	11111111-----
8	-----00000000
9	0001111111111111

14) Measure the mean output power in the following slots, not including the 25µs transient periods at the start and end of each slot:

CFN 6: Slot # 14
 CFN 7: Slots # 0 and 7
 CFN 8: Slots # 7 and 14
 CFN 9: Slot # 0

Also measure the mean output power in the transmission gap, not including the 25µs transient periods at the start and end of the transmission gap.

5.7.5 Test requirements

For ease of reference, the following uplink output power measurements are defined in Figure 5.7.4. In this figure:

- P_g is the mean power in an uplink transmission gap, excluding the 25 µs transient periods.
- P_a is the mean power in the last slot before a compressed frame (or pair of compressed frames), excluding the 25 µs transient periods.
- P_b is the mean power in the first slot of a compressed frame, excluding the 25 µs transient periods.
- P_c is the mean power in the last slot before a transmission gap, excluding the 25 µs transient periods.
- P_d is the mean power in the first slot after a transmission gap, excluding the 25 µs transient periods.
- P_e is the mean power in the last slot of a compressed frame, excluding the 25 µs transient periods.
- P_f is the mean power in the first slot after a compressed frame (or pair of compressed frames), excluding the 25 µs transient periods.

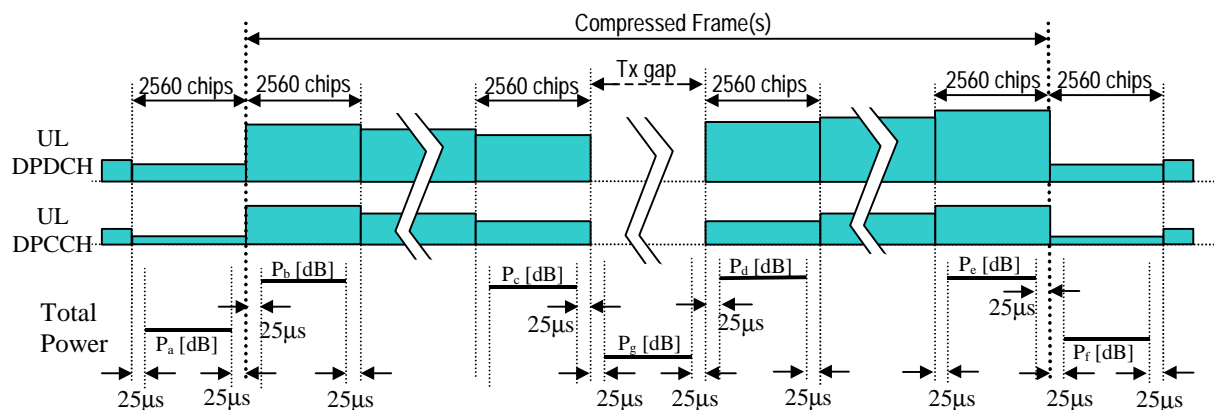

Figure 5.7.4: Uplink transmit power in uplink compressed mode

1. At the boundary between CFN 6 and CFN 7, $P_b - P_a$ shall be within the range $+4 \pm 2$ dB.
2. In slot #5 of CFN 2, the power difference $P_d - P_c$ from the power in slot #14 of CFN 1 shall be within the range -6 ± 3 dB.
3. In slot #5 of CFN 5, the power difference $P_d - P_c$ from the power in slot #14 of CFN 4 shall be within the range $+6 \pm 3$ dB.
4. In slot #7 of CFN 8, the power difference $P_d - P_c$ from the power in slot #7 of CFN 7 shall be within the range 0 ± 3 dB.
5. In CFNs 0, 1, 2, 3, 4, 5, 7 and 8, P_g shall be less than -56 dBm.
6. At the boundary between CFN 8 and CFN 9, $P_f - P_e$ shall be within the range -4 ± 2 dB.

7. In the slots between slot #6 of CFN 1 and slot #12 of CFN 1 inclusive, the change in mean output power from the previous slot shall be within the range given in Table 5.7.2 for TPC_cmd = +1.
8. The aggregate change in mean output power from slot #5 of CFN 1 to slot #12 of CFN 1 shall be within the range given in Table 5.7.3 for TPC_cmd = +1.
9. In the slots between slot #6 of CFN 4 and slot #12 of CFN 4 inclusive, the change in mean output power from the previous slot shall be within the range given in Table 5.7.2 for TPC_cmd = -1.
10. The aggregate change in mean output power from slot #5 of CFN 4 to slot #12 of CFN 4 shall be within the range given in Table 5.7.3 for TPC_cmd = -1.

5.8 Occupied Bandwidth (OBW)

5.8.1 Definition and applicability

Occupied bandwidth is a measure of the bandwidth containing 99 % of the total integrated power of the transmitted spectrum, centred on the assigned channel frequency.

The requirements and this test apply to all types of UTRA for the FDD UE.

5.8.2 Minimum Requirements

The occupied channel bandwidth shall be less than 5 MHz based on a chip rate of 3.84 Mcps.

The normative reference for this requirement is [1] TS 25.101 subclause 6.6.1.

5.8.3 Test purpose

To verify that the UE occupied channel bandwidth is less than 5 MHz based on a chip rate of 3.84 Mcps.

Excess occupied channel bandwidth increases the interference to other channels or to other systems.

5.8.4 Method of test

5.8.4.1 Initial conditions

- 1) Connect the SS to the UE antenna connector as shown in Figure A.1.
- 2) A call is set up according to the Generic call setup procedure
- 3) Enter the UE into loopback test mode and start the loopback test.

See [3] TS 34.108 and [4] TS 34.109 for details regarding generic call setup procedure and loopback test.

5.8.4.2 Procedure

- 1) Set and send continuously Up power control commands to the UE until the UE output power shall be maximum level.
- 2) Measure the power spectrum distribution within two times or more range over the requirement for Occupied Bandwidth specification centring on the current carrier frequency with 30 kHz or less RBW. The characteristic of the filter shall be approximately Gaussian (typical spectrum analyzer filter).
- 3) Calculate the total power within the range of all frequencies measured in '2)' and save this value as "Total Power".
- 4) Sum up the power upward from the lower boundary of the measured frequency range in '2)' and seek the limit frequency point by which this sum becomes 0.5 % of "Total Power" and save this point as "Lower Frequency".

- 5) Sum up the power downward from the upper boundary of the measured frequency range in '2)' and seek the limit frequency point by which this sum becomes 0.5 % of "Total Power" and save this point as "Upper Frequency".
- 6) Calculate the difference ("Upper Frequency" – "Lower Frequency" = "Occupied Bandwidth") between two limit frequencies obtained in '4)' and '5)'.

5.8.5 Test Requirements

The measured Occupied Bandwidth, derived in step 6), shall not exceed 5 MHz.

NOTE: If the above Test Requirement differs from the Minimum Requirement then the Test Tolerance applied for this test is non-zero. The Test Tolerance for this test is defined in Annex F.2 and the explanation of how the Minimum Requirement has been relaxed by the Test Tolerance is given in Annex F.4.

5.9 Spectrum emission mask

5.9.1 Definition and applicability

The spectrum emission mask of the UE applies to frequencies, which are between 2.5 MHz and 12.5 MHz away from the UE centre carrier frequency. The out of channel emission is specified relative to the UE output power measured in a 3.84 MHz bandwidth.

The requirements and this test apply to all types of UTRA for the FDD UE.

5.9.2 Minimum Requirements

The power of any UE emission shall not exceed the levels specified in Table 5.9.1.

Table 5.9.1: Spectrum Emission Mask Requirement

Frequency offset from carrier Δf	Minimum requirement	Measurement bandwidth
2.5 - 3.5 MHz	$-35 - 15*(\Delta f - 2.5)$ dBc	30 kHz *
3.5 - 7.5 MHz	$-35 - 1*(\Delta f - 3.5)$ dBc	1 MHz *
7.5 - 8.5 MHz	$-39 - 10*(\Delta f - 7.5)$ dBc	1 MHz *
8.5 - 12.5 MHz	-49 dBc	1 MHz *

NOTE*:

1. The first and last measurement position with a 30 kHz filter is 2.515 MHz and 3.485 MHz.
2. The first and last measurement position with a 1 MHz filter is 4 MHz and 12 MHz. As a general rule, the resolution bandwidth of the measuring equipment should be equal to the measurement bandwidth. To improve measurement accuracy, sensitivity and efficiency, the resolution bandwidth can be different from the measurement bandwidth. When the resolution bandwidth is smaller than the measurement bandwidth, the result should be integrated over the measurement bandwidth.
3. The lower limit shall be -50 dBm / 3.84 MHz or which ever is higher.

The normative reference for this requirement is [1] TS 25.101 subclause 6.6.2.1.1.

5.9.3 Test purpose

To verify that the power of UE emission does not exceed the prescribed limits shown in Table 5.9.1.

Excess emission increases the interference to other channels or to other systems.

5.9.4 Method of test

5.9.4.1 Initial conditions

- 1) Connect the SS to the UE antenna connector as shown in Figure A.1.
- 2) A call is set up according to the Generic call setup procedure.
- 3) Enter the UE into loopback test mode and start the loopback test.

See [3] TS 34.108 and [4] TS 34.109 for details regarding generic call setup procedure and loopback test.

5.9.4.2 Procedure

- 1) Set and send continuously Up power control commands to the UE until the UE output power shall be maximum level.
- 2) Measure the power of the transmitted signal with a measurement filter of bandwidths according to Table 5.9.2. Measurements with an offset from the carrier centre frequency between 2.515 MHz and 3.485 MHz shall use a 30 kHz measurement filter. Measurements with an offset from the carrier centre frequency between 4 MHz and 12 MHz shall use 1 MHz measurement bandwidth and the result may be calculated by integrating multiple 50 kHz or narrower filter measurements. The characteristic of the filter shall be approximately Gaussian (typical spectrum analyzer filter). The centre frequency of the filter shall be stepped in contiguous steps according to Table 5.9.2. The measured power shall be recorded for each step.
- 3) Measure the wanted output power according to Annex B.
- 4) Calculate the ratio of the power 2) with respect to 3) in dBc.

5.9.5 Test requirements

The result of 5.9.4.2 step 4) shall fulfil the requirements of Table 5.9.2.

Table 5.9.2: Spectrum Emission Mask Requirement

Frequency offset from carrier Δf	Minimum requirement	Measurement bandwidth
2.5 - 3.5 MHz	$-33.5 - 15*(\Delta f - 2.5)$ dBc	30 kHz *
3.5 - 7.5 MHz	$-33.5 - 1*(\Delta f - 3.5)$ dBc	1 MHz *
7.5 - 8.5 MHz	$-37.5 - 10*(\Delta f - 7.5)$ dBc	1 MHz *
8.5 - 12.5 MHz	-47.5 dBc	1 MHz *

NOTE*:

1. The first and last measurement position with a 30 kHz filter is 2.515 MHz and 3.485 MHz.
2. The first and last measurement position with a 1 MHz filter is 4 MHz and 12 MHz. As a general rule, the resolution bandwidth of the measuring equipment should be equal to the measurement bandwidth. To improve measurement accuracy, sensitivity and efficiency, the resolution bandwidth can be different from the measurement bandwidth. When the resolution bandwidth is smaller than the measurement bandwidth, the result should be integrated over the measurement bandwidth.
3. The lower limit shall be -48.5 dBm / 3.84 MHz or which ever is higher.
4. If the above Test Requirement differs from the Minimum Requirement then the Test Tolerance applied for this test is non-zero. The Test Tolerance for this test is defined in Annex F.2 and the explanation of how the Minimum Requirement has been relaxed by the Test Tolerance is given in Annex F.4.

5.10 Adjacent Channel Leakage Power Ratio (ACLR)

5.10.1 Definition and applicability

ACLR is the ratio of the transmitted power to the power measured in an adjacent channel. Both the transmitted power and the adjacent channel power are measured with a filter that has a Root-Raised Cosine (RRC) filter response with roll-off $\alpha=0.22$ and a bandwidth equal to the chip rate.

The requirements and this test apply to all types of UTRA for the FDD UE.

5.10.2 Minimum Requirements

If the adjacent channel power is greater than -50dBm then the ACLR should be higher than the value specified in Table 5.10.1.

Table 5.10.1: UE ACLR due to modulation

Power Class	UE channel	ACLR limit
3	+ 5 MHz or – 5 MHz	33 dB
	+ 10 MHz or – 10 MHz	43 dB
4	+ 5 MHz or – 5 MHz	33 dB
	+ 10 MHz or – 10 MHz	43 dB

The normative reference for this requirement is [1] TS 25.101 subclause 6.6.2.2.1.

5.10.3 Test purpose

To verify that the UE ACLR due to modulation does not exceed prescribed limit shown in Table 5.10.1.

Excess ACLR increase the interference to other channels or to other systems.

5.10.4 Method of test

5.10.4.1 Initial conditions

- 1) Connect the SS to the UE antenna connector as shown in Figure A.1.
- 2) A call is set up according to the Generic call setup procedure.
- 3) Enter the UE into loopback test mode and start the loopback test.

See [3] TS 34.108 and [4] TS 34.109 for details regarding generic call setup procedure and loopback test.

5.10.4.2 Procedure

- 1) Set and send continuously Up power control commands to the UE until the UE output power shall be maximum level.
- 2) Measure the power within the bandwidth of current carrier through a matched filter (RRC 0.22).
- 3) Measure the power fallen in the bandwidth of the first adjacent channels and the second adjacent channels through a matched filter (RRC 0.22).
- 4) Calculate the ratio of the power between the values measured in '2)' and '3)'.

5.10.5 Test requirements

If the measured adjacent channel power, derived in step 3), is greater than -50dBm then the measured ACLR, derived in step 4), shall be higher than the limit in Table 5.10.2.

Table 5.10.2: UE ACLR due to modulation

Power Class	UE channel	ACLR limit
3	+ 5 MHz or – 5 MHz	32.2 dB
	+ 10 MHz or – 10 MHz	42.2 dB
4	+ 5 MHz or – 5 MHz	32.2 dB
	+ 10 MHz or – 10 MHz	42.2 dB

NOTE: If the above Test Requirement differs from the Minimum Requirement then the Test Tolerance applied for this test is non-zero. The Test Tolerance for this test is defined in Annex F.2 and the explanation of how the Minimum Requirement has been relaxed by the Test Tolerance is given in Annex F.4.

5.11 Spurious Emissions

5.11.1 Definition and applicability

Spurious emissions are emissions which are caused by unwanted transmitter effects such as harmonics emission, parasitic emission, intermodulation products and frequency conversion products, but exclude out of band emissions.

The frequency boundary and the detailed transitions of the limits between the requirement for out band emissions and spectrum emissions are based on ITU-R Recommendations SM.329.

The requirements and this test apply to all types of UTRA for the FDD UE.

5.11.2 Minimum Requirements

These requirements are only applicable for frequencies, which are greater than 12.5 MHz away from the UE centre carrier frequency.

Table 5.11.1a: General spurious emissions requirements

Frequency Bandwidth	Resolution Bandwidth	Minimum requirement
$9\text{ kHz} \leq f < 150\text{ kHz}$	1 kHz	-36 dBm
$150\text{ kHz} \leq f < 30\text{ MHz}$	10 kHz	-36 dBm
$30\text{ MHz} \leq f < 1000\text{ MHz}$	100 kHz	-36 dBm
$1\text{ GHz} \leq f < 12.75\text{ GHz}$	1 MHz	-30 dBm

Table 5.11.1b: Additional spurious emissions requirements

Frequency Bandwidth	Resolution Bandwidth	Minimum requirement
$1893.5\text{ MHz} < f < 1919.6\text{ MHz}$	300 kHz	-41 dBm
$925\text{ MHz} \leq f \leq 935\text{ MHz}$	100 kHz	-67 dBm^*
$935\text{ MHz} < f \leq 960\text{ MHz}$	100 kHz	-79 dBm^*
$1805\text{ MHz} \leq f \leq 1880\text{ MHz}$	100 kHz	-71 dBm^*

*NOTE: The measurements are made on frequencies which are integer multiples of 200 kHz. As exceptions, up to five measurements with a level up to the applicable requirements defined in Table 5.11.1b are permitted for each UARFCN used in the measurement.

The normative reference for this requirement is [1] TS 25.101 subclause 6.6.3.1.

5.11.3 Test purpose

To verify that the UE spurious emissions do not exceed described value shown in Table 5.11.1a and Table 5.11.1b.

Excess spurious emissions increase the interference to other systems.

5.11.4 Method of test

5.11.4.1 Initial conditions

- 1) Connect the SS to the UE antenna connector as shown in Figure A.8.
- 2) A call is set up according to the Generic call setup procedure.
- 3) Enter the UE into loopback test mode and start the loopback test.

See [3] TS 34.108 and [4] TS 34.109 for details regarding generic call setup procedure and loopback test.

5.11.4.2 Procedure

- 1) Set and send continuously Up power control commands to the UE until the UE output power shall be maximum level.
- 2) Sweep the spectrum analyzer (or equivalent equipment) over a frequency range and measure the average power of spurious emission.

5.11.5 Test requirements

The measured average power of spurious emission, derived in step 2), shall not exceed the described value in Table 5.11.2a and 5.11.2b.

These requirements are only applicable for frequencies, which are greater than 12.5 MHz away from the UE centre carrier frequency.

Table 5.11.2a: General spurious emissions test requirements

Frequency Bandwidth	Resolution Bandwidth	Minimum requirement
$9 \text{ kHz} \leq f < 150 \text{ kHz}$	1 kHz	-36 dBm
$150 \text{ kHz} \leq f < 30 \text{ MHz}$	10 kHz	-36 dBm
$30 \text{ MHz} \leq f < 1000 \text{ MHz}$	100 kHz	-36 dBm
$1 \text{ GHz} \leq f < 12.75 \text{ GHz}$	1 MHz	-30 dBm

Table 5.11.2b: Additional spurious emissions test requirements

Frequency Bandwidth	Resolution Bandwidth	Minimum requirement
$1893.5 \text{ MHz} < f < 1919.6 \text{ MHz}$	300 kHz	-41 dBm
$925 \text{ MHz} \leq f \leq 935 \text{ MHz}$	100 kHz	-67 dBm *
$935 \text{ MHz} < f \leq 960 \text{ MHz}$	100 kHz	-79 dBm *
$1805 \text{ MHz} \leq f \leq 1880 \text{ MHz}$	100 kHz	-71 dBm *

NOTE:

1. The measurements are made on frequencies which are integer multiples of 200 kHz. As exceptions, up to five measurements with a level up to the applicable requirements defined in Table 5.11.2b are permitted for each UARFCN used in the measurement.
2. If the above Test Requirement differs from the Minimum Requirement then the Test Tolerance applied for this test is non-zero. The Test Tolerance for this test is defined in Annex F.2 and the explanation of how the Minimum Requirement has been relaxed by the Test Tolerance is given in Annex F.4.

5.12 Transmit Intermodulation

5.12.1 Definition and applicability

The transmit intermodulation performance is a measure of the capability of the transmitter to inhibit the generation of signals in its non linear elements caused by presence of the wanted signal and an interfering signal reaching the transmitter via the antenna.

UE(s) transmitting in close vicinity of each other can produce intermodulation products, which can fall into the UE, or Node B receive band as an unwanted interfering signal. The UE transmit intermodulation attenuation is defined by the ratio of the output power of the wanted signal to the output power of the intermodulation product when an interfering CW signal is added at a level below the wanted signal. Both the wanted signal power and the IM product power are measured with a filter that has a Root-Raised Cosine (RRC) filter response with roll-off $\alpha = 0,22$ and a bandwidth equal to the chip rate.

The requirements and this test apply to all types of UTRA for the FDD UE.

5.12.2 Minimum Requirements

The UE transmit intermodulation shall not exceed the described value in Table 5.12.1.

Table 5.12.1: Transmit Intermodulation

CW Signal Frequency Offset from Transmitting Carrier	5MHz	10MHz
Interference CW Signal Level	-40 dBc	
Intermodulation Product	-31 dBc	-41 dBc

The normative reference for this requirement is [1] TS 25.101 subclause 6.7.1.

5.12.3 Test purpose

To verify that the UE transmit intermodulation does not exceed the described value in Table 5.12.1.

An excess transmit intermodulation increases transmission errors in the up link own channel when other transmitter exists nearby.

5.12.4 Method of test

5.12.4.1 Initial conditions

- 1) Connect the SS to the UE antenna connector as shown in Figure A.2.
- 2) A call is set up according to the Generic call setup procedure.
- 3) Enter the UE into loopback test mode and start the loopback test.

See [3] TS 34.108 and [4] TS 34.109 for details regarding generic call setup procedure and loopback test.

5.12.4.2 Procedure

- 1) Set and send continuously Up power control commands to the UE until the UE output power shall be maximum level.
- 2) Set the frequency of the CW generator to the offset 1 or offset 2 as shown in Table 5.12.2.
- 3) Measure the average output power of the UE by spectrum analyzer (or equivalent equipment) through RRC filter.
- 4) Search the intermodulation product signal, then measure the average power of transmitting intermodulation through RRC filter, and calculate the ratio to the average output power of UE.

5) Repeat the measurement with another tone offset.

5.12.5 Test requirements

The measured average power of transmit intermodulation, derived in step 4), shall not exceed the described value in Table 5.12.2.

Table 5.12.2: Transmit Intermodulation

CW Signal Frequency Offset from Transmitting Carrier	5MHz	10MHz
Interference CW Signal Level	-40 dBc	
Intermodulation Product	$[-31 + TT]$ dBc	$[-41 + TT]$ dBc

NOTE: If the above Test Requirement differs from the Minimum Requirement then the Test Tolerance applied for this test is non-zero. The Test Tolerance for this test is defined in Annex F.2 and the explanation of how the Minimum Requirement has been relaxed by the Test Tolerance is given in Annex F.4.

5.13 Transmit Modulation

5.13.1 Error Vector Magnitude (EVM)

5.13.1.1 Definition and applicability

The Error Vector Magnitude (EVM) is a measure of the difference between the measured waveform and the theoretical modulated waveform (the error vector). It is the square root of the ratio of the mean error vector power to the mean reference signal power expressed as a %. The measurement interval is one power control group (timeslot).

The requirements and this test apply to all types of UTRA for the FDD UE.

5.13.1.2 Minimum Requirements

The EVM shall not exceed 17,5 % for the parameters specified in Table 5.13.1.

Table 5.13.1: Parameters for EVM

Parameter	Level / Status	Unit
Output power	≥ -20	dBm
Operating conditions	Normal conditions	
Power control step size	1	dB

The normative reference for this requirement is [1] TS 25.101 clause 6.8.2.1.

5.13.1.3 Test purpose

To verify that the EVM does not exceed 17.5 % for the specified parameters in Table 5.13.1.

An excess EVM increases transmission errors in the up link own channel.

5.13.1.4 Method of test

5.13.1.4.1 Initial conditions

- 1) Connect the SS to the UE antenna connector as shown in Figure A.1.
- 2) A call is set up according to the Generic call setup procedure.
- 3) Enter the UE into loopback test mode and start the loopback test.

See [3] TS 34.108 and [4] TS 34.109 for details regarding generic call setup procedure and loopback test.

5.13.1.4.2 Procedure

- 1) Set and send continuously Up power control commands to the UE until the UE output power shall be maximum level.
- 2) Measure the EVM using Global In-Channel Tx-Test (Annex B).
- 3) Set the power level of UE to -20dBm or send Down power control commands (1dB step size should be used.) to the UE until UE output power shall be -20dBm with $\pm 1\text{dB}$ tolerance.
- 4) Repeat step 2).

5.13.1.5 Test requirements

The measured EVM, derived in step 2) and 4), shall not exceed 17.5%. for parameters specified in table 5.13.1 Parameters for EVM.

NOTE: If the above Test Requirement differs from the Minimum Requirement then the Test Tolerance applied for this test is non-zero. The Test Tolerance for this test is defined in Annex F.2 and the explanation of how the Minimum Requirement has been relaxed by the Test Tolerance is given in Annex

5.13.2 Peak code domain error

5.13.2.1 Definition and applicability

The Peak Code Domain Error is computed by projecting power of the error vector (as defined in 5.13.1.1) onto the code domain at a specific spreading factor. The Code Domain Error for every code in the domain is defined as the ratio of the mean power of the projection onto that code, to the mean power of the composite reference waveform expressed in dB. The Peak Code Domain Error is defined as the maximum value for the Code Domain Error for all codes. The measurement interval is one power control group (timeslot).

The requirements and this test apply only to the UE in which the multi-code transmission is provided.

5.13.2.2 Minimum Requirements

The peak code domain error shall not exceed -15 dB at spreading factor 4 for the parameters specified in Table 5.13.3. The requirements are defined using the UL reference measurement channel (768 kbps) specified in subclause C.2.5.

Table 5.13.3: Parameters for Peak code domain error

Parameter	Level / Status	Unit
Output power	≥ -20	dBm
Operating conditions	Normal conditions	
Power control step size	1	dB

The normative reference for this requirement is [1] TS 25.101 subclause 6.8.3.1.

5.13.2.3 Test purpose

To verify that the UE peak code domain error does not exceed -15 dB for the specified parameters in Table 5.13.3.

An excess peak code domain error increases transmission errors in the up link own channel.

5.13.2.4 Method of test

5.13.2.4.1 Initial conditions

- 1) Connect the SS to the UE antenna connector as shown in Figure A.1.
- 2) A call is set up according to the Generic call setup procedure, and RF parameters are set up according to Table 5.13.4.
- 3) Enter the UE into loopback test mode and start the loopback test.

See [3] TS 34.108 and [4] TS 34.109 for details regarding generic call setup procedure and loopback test.

Table 5.13.4: Test parameters for Peak code domain error

Parameter	Level / Status	Unit
Operating conditions	Normal conditions	
Uplink signal	multi-code	
Information bit rate	2*384	kbps
Power control step size	1	dB

5.13.2.4.2 Procedure

- 1) Set and send continuously Up power control commands to the UE until the UE output power shall be maximum level.
- 2) Measure the Peak code Domain error using Global In-Channel Tx-Test (Annex B).
- 3) Set the power level of UE to -20dBm or send Down power control commands (1dB step size should be used.) to the UE until UE output power shall be -20dBm with +/- 1dB tolerance.
- 4) Repeat step 2).

5.13.2.5 Test requirements

The measured Peak code domain error, derived in step 2) and 4), shall not exceed -14 dB.

NOTE: If the above Test Requirement differs from the Minimum Requirement then the Test Tolerance applied for this test is non-zero. The Test Tolerance for this test is defined in Annex F.2 and the explanation of how the Minimum Requirement has been relaxed by the Test Tolerance is given in Annex F.4

6 Receiver Characteristics

6.1 General

Receiving performance test of the UE is implemented during communicating with the SS via air interface. The procedure is using normal call protocol until the UE is communicating on traffic channel basically. On the traffic channel, the UE provides special function for testing that is called Logical Test Interface and the UE is tested using this function (Refer to [4] TS 34.109)

Transmitting or receiving bit/symbol rate for test channel is shown in Table 6.1.

Table 6.1: Bit / Symbol rate for Test Channel

Type of User Information	User bit rate	DL DPCH symbol rate	UL DPCH bit rate	Remarks
12.2 kbps reference measurement channel	12.2 kbps	30 ksps	60 kbps	Standard Test

Unless otherwise stated the receiver characteristics are specified at the antenna connector of the UE. For UE(s) with an integral antenna only, a reference antenna with a gain of 0 dBi is assumed. UE with an integral antenna may be taken into account by converting these power levels into field strength requirements, assuming a 0 dBi gain antenna. Receiver characteristics for UE(s) with multiple antennas/antenna connectors are FFS.

The UE antenna performance has a significant impact on system performance, and minimum requirements on the antenna efficiency are therefore intended to be included in future versions of this specification. It is recognised that different requirements and test methods are likely to be required for the different types of UE.

All the parameters in clause 6 are defined using the DL reference measurement channel (12.2 kbps) specified in subclause C.3.1 and unless stated otherwise, with DL power control OFF.

The common RF test conditions of Rx Characteristics are defined in Annex E.3.2, and each test conditions in this clause (clause 6) should refer Annex E.3.2. Individual test conditions are defined in the paragraph of each test.

6.2 Reference Sensitivity Level

6.2.1 Definition and applicability

The reference sensitivity is the minimum receiver input power measured at the antenna port at which the Bit Error Ratio (BER) does not exceed a specific value

The requirements and this test apply to all types of UTRA for the FDD UE.

6.2.2 Minimum Requirements

The BER shall not exceed 0.001 for the parameters specified in Table 6.2.1.

Table 6.2.1: Test parameters for Reference Sensitivity Level

Parameter	Level / Status	Unit
\hat{I}_{or}	-106.7	dBm / 3.84 MHz
DPCH_Ec	-117	dBm / 3.84 MHz

The normative reference for this requirement is [1] TS 25.101 subclause 7.3.1.

6.2.3 Test purpose

To verify that the UE BER does not exceed 0.001 for the parameters specified in Table 6.2.

The lack of the reception sensitivity decreases the coverage area at the far side from Node B.

6.2.4 Method of test

6.2.4.1 Initial conditions

- 1) Connect the SS to the UE antenna connector as shown in Figure A.3.
- 2) A call is set up according to the Generic call setup procedure, and RF parameters are set up according to Table 6.2.2.
- 3) Enter the UE into loopback test mode and start the loopback test.

See [3] TS 34.108 and [4] TS 34.109 for details regarding generic call setup procedure and loopback test.

6.2.4.2 Procedure

- 1) Set and send continuously Up power control commands to the UE until the UE output power shall be maximum level.
- 2) Measure the BER of DCH received from the UE at the SS.

6.2.5 Test requirements

The measured BER, derived in step 2), shall not exceed 0.001.

Table 6.2.2: Test parameters for Reference Sensitivity Level

Parameter	Level / Status	Unit
\hat{I}_{or}	-106	dBm / 3.84 MHz
DPCH_Ec	-116.3	dBm / 3.84 MHz

NOTE: If the above Test Requirement differs from the Minimum Requirement then the Test Tolerance applied for this test is non-zero. The Test Tolerance for this test is defined in Annex F.2 and the explanation of how the Minimum Requirement has been relaxed by the Test Tolerance is given in Annex F.4.

6.3 Maximum Input Level

6.3.1 Definition and applicability

This is defined as the maximum receiver input power at the UE antenna port which does not degrade the specified BER performance.

The requirements and this test apply to all types of UTRA for the FDD UE.

6.3.2 Conformance requirements

The BER shall not exceed 0.001 for the parameters specified in Table 6.3.

The reference for this requirement is [1] TS 25.101 subclause 7.4.1.

NOTE: Since the spreading factor is large ($10\log(SF)=21\text{dB}$), the majority of the total input signal consists of the OCNS interference. The structure of OCNS signal is defined in Annex E.3.2.

6.3.3 Test purpose

To verify that the UE BER does not exceed 0.001 for the parameters specified in Table 6.3.

The lack of the maximum input level decreases the coverage area at the near side from Node B.

6.3.4 Method of test

6.3.4.1 Initial conditions

- 1) Connect the SS to the UE antenna connector as shown in Figure A.3.
- 2) A call is set up according to the Generic call setup procedure, and RF parameters are set up according to Table 6.3 and Table E.3.3.
- 3) Enter the UE into loopback test mode and start the loopback test.

See [3] TS 34.108 and [4] TS 34.109 for details regarding generic call setup procedure and loopback test.

Table 6.3: Test parameters for Maximum Input Level

Parameter	Level / Status	Unit
I_{or}	-25	dBm / 3.84MHz
$\frac{DPCH_E_c}{I_{or}}$	-19	dB

6.3.4.2 Procedure

- 1) Measure the BER of DCH received from the UE at the SS.

6.3.5 Test requirements

The measured BER, derived in step 1), shall not exceed 0.001.

6.4 Adjacent Channel Selectivity (ACS)

6.4.1 Definition and applicability

Adjacent Channel Selectivity (ACS) is a measure of a receiver's ability to receive a W-CDMA signal at its assigned channel frequency in the presence of an adjacent channel signal at a given frequency offset from the centre frequency of the assigned channel. ACS is the ratio of the receive filter attenuation on the assigned channel frequency to the receive filter attenuation on the adjacent channel(s).

The requirements and this test apply to all types of UTRA for the FDD UE.

6.4.2 Minimum Requirements

For the UE of power class 3 and 4, the BER shall not exceed 0.001 for the parameters specified in Table 6.4.1. This test condition is equivalent to the ACS value 33 dB.

Table 6.4.1: Test parameters for Adjacent Channel Selectivity

Parameter	Level / Status	Unit
DPCH_Ec	-103	dBm / 3.84 MHz
I_{or}	-92.7	dBm / 3.84 MHz
I_{oac} (modulated)	-52	dBm / 3.84 MHz
F_{uw} (offset)	-5 or +5	MHz

The normative reference for this requirement is [1] TS 25.101 subclause 7.5.1.

Note: The I_{oac} (modulated) signal consists of common channels needed for tests and 16 dedicated data channels. The channelisation codes for data channels are chosen optimally to reduce peak to average ratio (PAR). All dedicated channels user data is uncorrelated to each other.

6.4.3 Test purpose

To verify that the UE BER does not exceed 0.001 for the test parameters specified in Table 6.4.1.

The lack of the ACS decreases the coverage area when other transmitter exists in the adjacent channel.

6.4.4 Method of test

6.4.4.1 Initial conditions

- 1) Connect the SS to the UE antenna connector as shown in Figure A.4.
- 2) A call is set up according to the Generic call setup procedure, and RF parameters are set up according to Table 6.4.2.
- 3) Enter the UE into loopback test mode and start the loopback test.

See [3] TS 34.108 and [4] TS 34.109 for details regarding generic call setup procedure and loopback test.

6.4.4.2 Procedure

- 1) Set the parameters of the interference signal generator as shown in Table 6.4.2.
- 2) Measure the BER of DCH received from the UE at the SS.

6.4.5 Test requirements

The measured BER, derived in step 1), shall not exceed 0.001.

Table 6.4.2: Test parameters for Adjacent Channel Selectivity

Parameter	Level / Status	Unit
DPCH_Ec	-103	dBm / 3.84 MHz
I_{or}	-92.7	dBm / 3.84 MHz
I_{oac} (modulated)	-52	dBm / 3.84 MHz
F_{uw} (offset)	-5 or +5	MHz

NOTE: If the above Test Requirement differs from the Minimum Requirement then the Test Tolerance applied for this test is non-zero. The Test Tolerance for this test is defined in Annex F.2 and the explanation of how the Minimum Requirement has been relaxed by the Test Tolerance is given in Annex F.4.

6.5 Blocking Characteristics

6.5.1 Definition and applicability

The blocking characteristic is a measure of the receiver's ability to receive a wanted signal at its assigned channel frequency in the presence of an unwanted interferer on frequencies other than those of the spurious response or the adjacent channels, without this unwanted input signal causing a degradation of the performance of the receiver beyond a specified limit. The blocking performance shall apply at all frequencies except those at which a spurious response occur.

The requirements and this test apply to all types of UTRA for the FDD UE.

6.5.2 Minimum Requirements

The BER shall not exceed 0.001 for the parameters specified in Table 6.5.1 and Table 6.5.2. For Table 6.5.2 up to (24) exceptions are allowed for spurious response frequencies in each assigned frequency channel when measured using a 1 MHz step size.

The normative reference for this requirement is [1] TS 25.101 subclause 7.6.1.

Note: I_{blocking} (modulated) consists of common channels and 16 dedicated data channels. The channelisation codes for data channels are chosen optimally to reduce peak to average ratio (PAR). All dedicated channels user data is uncorrelated to each other.

Table 6.5.1: Test parameters for In-band blocking characteristics

Parameter	10 MHz offset	15 MHz offset	Unit
DPCH_Ec	-114	-114	dBm / 3.84 MHz
I_{or}	-103.7	-103.7	dBm / 3.84 MHz
I_{blocking} (modulated)	-56	-44	dBm / 3.84 MHz
F_{uw} (offset)	+10 or -10	+15 or -15	MHz

Table 6.5.2: Test parameters for Out of band blocking characteristics

Parameter	Band 1	Band 2	Band 3	Unit
DPCH_Ec	-114	-114	-114	dBm / 3.84MHz
I_{or}	-103.7	-103.7	-103.7	dBm / 3.84MHz
I_{blocking} (CW)	-44	-30	-15	dBm
F_{uw} For operation in frequency bands as defined in subclause 4.2(a)	2050 < f < 2095 2185 < f < 2230	2025 < f < 2050 2230 < f < 2255	1 < f < 2025 2255 < f < 12750	MHz
F_{uw} For operation in frequency bands as defined in subclause 4.2(b)	1870 < f < 1915 2005 < f < 2050	1845 < f < 1870 2050 < f < 2075	1 < f < 1845 2075 < f < 12750	MHz

NOTE:

1. For operation in bands referenced in 4.2(a), from 2095 < f < 2110 MHz and 2170 < f < 2185 MHz, the appropriate in-band blocking or adjacent channel selectivity in subclause 6.4.2 shall be applied.
2. For operation in bands referenced in 4.2(b), 1915 < f < 1930 MHz and 1990 < f < 2005 MHz, the appropriate in-band blocking or adjacent channel selectivity in subclause 6.4.2 shall be applied.

6.5.3 Test purpose

To verify that the UE BER does not exceed 0.001 for the parameters specified in Table 6.5.1 and Table 6.5.2. For Table 6.5.2 up to (24) exceptions are allowed for spurious response frequencies in each assigned frequency channel when measured using a 1 MHz step size.

The lack of the blocking ability decreases the coverage area when other transmitter exists (except in the adjacent channels and spurious response).

6.5.4 Method of test

6.5.4.1 Initial conditions

- 1) Connect the SS to the UE antenna connector as shown in Figure A.5.
- 2) A call is set up according to the Generic call setup procedure, and RF parameters are set up according to Table 6.5.3 and Table 6.5.4.
- 3) Enter the UE into loopback test mode and start the loopback test.

See [3] TS 34.108 and [4] TS 34.109 for details regarding generic call setup procedure and loopback test.

6.5.4.2 Procedure

- 1) Set the parameters of the CW generator or the interference signal generator as shown in Table 6.5.3 and Table 6.5.4. For Table 6.5.4, the frequency step size is 1 MHz.
- 2) Measure the BER of DCH received from the UE at the SS.
- 3) For Table 6.5.4, record the frequencies for which BER exceed the test requirements.

6.5.5 Test requirements

For Table 6.5.3, the measured BER, derived in step 2), shall not exceed 0.001. For Table 6.5.4, the measured BER, derived in step 2) shall not exceed 0.001 except for the spurious response frequencies, recorded in step 3). The number of spurious response frequencies, recorded in step 3) shall not exceed 24.

Table 6.5.3: Test parameters for In-band blocking characteristics

Parameter	10 MHz offset	15 MHz offset	Unit
DPCH_Ec	-114	-114	dBm / 3.84 MHz
I _{or}	-103.7	-103.7	dBm / 3.84 MHz
I _{blocking} (modulated)	-56	-44	dBm / 3.84 MHz
F _{uw} (offset)	+10 or -10	+15 or -15	MHz

Table 6.5.4: Test parameters for Out of band blocking characteristics

Parameter	Band 1	Band 2	Band 3	Unit
DPCH_Ec	-114	-114	-114	dBm / 3.84MHz
\hat{I}_{or}	-103.7	-103.7	-103.7	dBm / 3.84MHz
$I_{blocking}(CW)$	-44	-30	-15	dBm
F_{uw} For operation in frequency bands as defined in subclause 4.2(a)	2050 < f < 2095 2185 < f < 2230	2025 < f < 2050 2230 < f < 2255	1 < f < 2025 2255 < f < 12750	MHz
F_{uw} For operation in frequency bands as defined in subclause 4.2(b)	1870 < f < 1915 2005 < f < 2050	1845 < f < 1870 2050 < f < 2075	1 < f < 1845 2075 < f < 12750	MHz

NOTE:

1. For operation in bands referenced in 4.2(a), from 2095 < f < 2110 MHz and 2170 < f < 2185 MHz, the appropriate in-band blocking or adjacent channel selectivity in subclause 6.4.2 shall be applied.
2. For operation in bands referenced in 4.2(b), 1915 < f < 1930 MHz and 1990 < f < 2005 MHz, the appropriate in-band blocking or adjacent channel selectivity in subclause 6.4.2 shall be applied.
3. If the above Test Requirement differs from the Minimum Requirement then the Test Tolerance applied for this test is non-zero. The Test Tolerance for this test is defined in Annex F.2 and the explanation of how the Minimum Requirement has been relaxed by the Test Tolerance is given in Annex F.4.

6.6 Spurious Response

6.6.1 Definition and applicability

Spurious response is a measure of the receiver's ability to receive a wanted signal on its assigned channel frequency without exceeding a given degradation due to the presence of an unwanted CW interfering signal at any other frequency at which a response is obtained i.e. for which the blocking limit is not met.

The requirements and this test apply to all types of UTRA for the FDD UE.

6.6.2 Minimum Requirements

The BER shall not exceed 0.001 for the parameters specified in Table 6.6.1.

The normative reference for this requirement is [1] TS 25.101 subclause 7.7.1.

Table 6.6.1: Test parameters for Spurious Response

Parameter	Level	Unit
DPCH_Ec	-114	dBm / 3.84MHz
\hat{I}_{or}	-103.7	dBm / 3.84MHz
$I_{blocking}(CW)$	-44	dBm
F_{uw}	Spurious response frequencies	MHz

6.6.3 Test purpose

To verify that the UE BER does not exceed 0.001 for the parameters specified in Table 6.6.1.

The lack of the spurious response ability decreases the coverage area when other unwanted interfering signal exists at any other frequency.

6.6.4 Method of test

6.6.4.1 Initial conditions

- 1) Connect the SS to the UE antenna connector as shown in Figure A.6.
- 2) A call is set up according to the Generic call setup procedure, and RF parameters are set up according to Table 6.6.2.
- 3) Enter the UE into loopback test mode and start the loopback test.

See [3] TS 34.108 and [4] TS 34.109 for details regarding generic call setup procedure and loopback test.

6.6.4.2 Procedure

- 1) Set the parameter of the CW generator as shown in Table 6.6.2. The spurious response frequencies are determined in step 3) of section 6.5.4.2.
- 2) Measure the BER of DCH received from the UE at the SS.

6.6.5 Test requirements

The measured BER, derived in step 2), shall not exceed 0.001.

Table 6.6.2: Test parameters for Spurious Response

Parameter	Level	Unit
DPCH_Ec	-114	dBm / 3.84MHz
I_{or}	-103.7	dBm / 3.84MHz
$I_{blocking}(CW)$	-44	dBm
F_{uw}	Spurious response frequencies	MHz

NOTE: If the above Test Requirement differs from the Minimum Requirement then the Test Tolerance applied for this test is non-zero. The Test Tolerance for this test is defined in Annex F.2 and the explanation of how the Minimum Requirement has been relaxed by the Test Tolerance is given in Annex F.4.

6.7 Intermodulation Characteristics

6.7.1 Definition and applicability

Third and higher order mixing of the two interfering RF signals can produce an interfering signal in the band of the desired channel. Intermodulation response rejection is a measure of the capability of the receiver to receive a wanted signal on its assigned channel frequency in the presence of two or more interfering signals which have a specific frequency relationship to the wanted signal.

The requirements and this test apply to all types of UTRA for the FDD UE.

6.7.2 Minimum Requirements

The BER shall not exceed 0.001 for the parameters specified in Table 6.7.1.

The normative reference for this requirement is [1] TS 25.101 subclause 7.8.1.

Note: I_{ouw2} (modulated) consists of common channels and 16 dedicated data channels. The channelisation codes for data channels are chosen optimally to reduce peak to average ratio (PAR). All dedicated channels user data is uncorrelated to each other.

Table 6.7.1: Test parameters for Intermodulation Characteristics

Parameter	Level		Unit
DPCH_Ec	-114		dBm / 3.84 MHz
I_{or}	-103.7		dBm / 3.84 MHz
I_{ouw1} (CW)	-46		dBm
I_{ouw2} (modulated)	-46		dBm / 3.84 MHz
F_{uw1} (offset)	10	-10	MHz
F_{uw2} (offset)	20	-20	MHz

6.7.3 Test purpose

To verify that the UE BER does not exceed 0.001 for the parameters specified in Table 6.7.1.

The lack of the intermodulation response rejection ability decreases the coverage area when two or more interfering signals, which have a specific frequency relationship to the wanted signal, exist.

6.7.4 Method of test

6.7.4.1 Initial conditions

- 1) Connect the SS to the UE antenna connector as shown in Figure A.7.
- 2) A call is set up according to the Generic call setup procedure, and RF parameters are set up according to Table 6.7.2.
- 3) Enter the UE into loopback test mode and start the loopback test.

See [3] TS 34.108 and [4] TS 34.109 for details regarding generic call setup procedure and loopback test.

6.7.4.2 Procedure

- 1) Set the parameters of the CW generator and interference signal generator as shown in Table 6.7.2.
- 2) Measure the BER of DCH received from the UE at the SS.

6.7.5 Test requirements

The measured BER, derived in step 1), shall not exceed 0.001.

Table 6.7.2: Test parameters for Intermodulation Characteristics

Parameter	Level		Unit
DPCH_Ec	-114		dBm / 3.84 MHz
I_{or}	-103.7		dBm / 3.84 MHz
I_{ouw1} (CW)	-46		dBm
I_{ouw2} (modulated)	-46		dBm / 3.84 MHz
F_{uw1} (offset)	10	-10	MHz
F_{uw2} (offset)	20	-20	MHz

NOTE: If the above Test Requirement differs from the Minimum Requirement then the Test Tolerance applied for this test is non-zero. The Test Tolerance for this test is defined in Annex F.2 and the explanation of how the Minimum Requirement has been relaxed by the Test Tolerance is given in Annex F.4.

6.8 Spurious Emissions

6.8.1 Definition and applicability

The spurious emissions power is the power of emissions generated or amplified in a receiver that appear at the UE antenna connector.

The requirements and this test apply to all types of UTRA for the FDD UE.

6.8.2 Minimum Requirements

The power of any narrow band CW spurious emission shall not exceed the maximum level specified in Table 6.8.1 and Table 6.8.2.

Table 6.8.1: General receiver spurious emission requirements

Frequency Band	Measurement Bandwidth	Maximum level	Note
$9\text{kHz} \leq f < 1\text{GHz}$	100 kHz	-57 dBm	
$1\text{GHz} \leq f \leq 12.75\text{ GHz}$	1 MHz	-47 dBm	

Table 6.8.2: Additional receiver spurious emission requirements

Frequency Band	Measurement Bandwidth	Maximum level	Note
$1920\text{ MHz} \leq f \leq 1980\text{ MHz}$	3.84 MHz	-60 dBm	Mobile transmit band in URA_PCH, Cell_PCH and idle state
$2110\text{ MHz} \leq f \leq 2170\text{ MHz}$	3.84 MHz	-60 dBm	Mobile receive band

The reference for this requirement is [1] TS 25.101 subclause 7.9.1.

6.8.3 Test purpose

To verify that the UE spurious emission meets the specifications described in subclause 6.8.2.

Excess spurious emissions increase the interference to other systems.

6.8.4 Method of test

6.8.4.1 Initial conditions

- 1) Connect a spectrum analyzer (or other suitable test equipment) to the UE antenna connector as shown in Figure A.8.
- 2) RF parameters are setup according to Table [TBD].
- 3) UE shall be camped on a cell
- 4) UE shall perform Location Registration (LR) before the test procedure in subclause 6.8.4.2, but not during it.
- 5) Neighbour cell list shall be empty.
- 6) Paging repetition period and DRX cycle shall be set to minimum (shortest possible time interval).

6.8.4.2 Procedure

- 1) Sweep the spectrum analyzer (or equivalent equipment) over a frequency range and measure the average power of spurious emission.

6.8.5 Test requirements

The all measured spurious emissions, derived in step 1), shall not exceed the maximum level specified in Table 6.8.3 and Table 6.8.4.

Table 6.8.3: General receiver spurious emission requirements

Frequency Band	Measurement Bandwidth	Maximum level	Note
$9\text{kHz} \leq f < 1\text{GHz}$	100 kHz	-57 dBm	
$1\text{GHz} \leq f \leq 12.75\text{ GHz}$	1 MHz	-47 dBm	

Table 6.8.4: Additional receiver spurious emission requirements

Frequency Band	Measurement Bandwidth	Maximum level	Note
$1920\text{ MHz} \leq f \leq 1980\text{ MHz}$	3.84 MHz	-60 dBm	Mobile transmit band in URA_PCH, Cell_PCH and idle state
$2110\text{ MHz} \leq f \leq 2170\text{ MHz}$	3.84 MHz	-60 dBm	Mobile receive band

NOTE: If the above Test Requirement differs from the Minimum Requirement then the Test Tolerance applied for this test is non-zero. The Test Tolerance for this test is defined in Annex F.2 and the explanation of how the Minimum Requirement has been relaxed by the Test Tolerance is given in Annex F.4.

7 Performance requirements

7.1 General

The performance requirements for the UE in this clause are specified for the measurement channels specified in Annex C and Table 7.1.1, the propagation conditions specified in 7.1.2 and the Down link Physical channels specified in Annex D. Unless stated otherwise, DL power control is OFF.

The method for Block Error Ratio (BLER) measurement is specified in [4] TS 34.109.

Table 7.1.1: Bit / Symbol rate for Test Channel

Type of User Information	User bit rate	DL DPCH symbol rate	UL DPCH bit rate
12.2 kbps reference measurement channel	12.2 kbps	30 ksps	60 kbps
64/144/384 kbps reference measurement channel	64 kbps	120 ksps	240 kbps
	144 kbps	240 ksps	480 kbps
	384 kbps	480 ksps	960 kbps

The common RF test conditions of Performance requirement are defined in Annex E.3.3, and each test conditions in this clause (clause 7) should refer Annex E.3.3. Individual test conditions are defined in the paragraph of each test.

7.1.1 Measurement Configurations

In all measurements UE should transmit with maximum power while receiving signals from Node B. Transmission Power Control is always disabled during the measurements. Chip Rate is specified to be 3.84 MHz.

It is assumed that fields inside DPCH have the same energy per PN chip. Also, if the power of S-CCPCH is not specified in the test parameter table, it should be set to zero. The power of OCNS should be adjusted that the power ratios (E_c/I_{or}) of all specified forward channels add up to one.

Measurement configurations for different scenarios are shown in Figure A.9, Figure A.10 and Figure A.11.

7.2 Demodulation in Static Propagation conditions

7.2.1 Demodulation of Dedicated Channel (DCH)

7.2.1.1 Definition and applicability

The receive characteristic of the Dedicated Channel (DCH) in the static environment is determined by the Block Error Ratio (BLER). BLER is specified for each individual data rate of the DCH. DCH is mapped into the Dedicated Physical Channel (DPCH).

The UE shall be tested only according to the data rate, supported. The data-rate-corresponding requirements shall apply to the UE.

7.2.1.2 Conformance requirements

For the parameters specified in Table 7.2.1.1 the average downlink $\frac{DPCH_E_c}{I_{or}}$ power shall be below the specified value for the BLER shown in Table 7.2.1.2. These requirements are applicable for TFCS size 16.

Table 7.2.1.1: DCH parameters in static propagation conditions

Parameter	Test 1	Test 2	Test 3	Test 4	Unit
Phase reference	P-CPICH				
\hat{I}_{or}/I_{oc}	-1				dB
I_{oc}	-60				dBm / 3.84 MHz
Information Data Rate	12,2	64	144	384	kbps

Table 7.2.1.2: DCH requirements in static propagation conditions

Test Number	$\frac{DPCH_E_c}{I_{or}}$	BLER
1	-16.6 dB	10^{-2}
2	-13.1 dB	10^{-1}
	-12.8 dB	10^{-2}
3	-9.9 dB	10^{-1}
	-9.8 dB	10^{-2}
4	-5.6 dB	10^{-1}
	-5.5 dB	10^{-2}

The reference for this requirement is [1] TS 25.101 subclause 8.2.3.1.

7.2.1.3 Test purpose

To verify the ability of the receiver to receive a predefined test signal, representing a static propagation channel for the wanted and for the co-channel signals from serving and adjacent cells, with a BLER not exceeding a specified value.

7.2.1.4 Method of test

7.2.1.4.1 Initial conditions

1. Connect the SS and an AWGN noise source to the UE antenna connector as shown in Figure A.9.
2. Set up a call according to the Generic call setup procedure.
3. Set the test parameters for test 1-5 as specified in Table 7.2.1.1.
4. Enter the UE into loopback test mode and start the loopback test.

7.2.1.4.2 Procedures

1. Measure BLER of DCH.

7.2.1.5 Test requirements

For the parameters specified in Table 7.2.1.1 the BLER shall not exceed the value at the $DPCH_{Ec}/I_{or}$ specified in Table 7.2.1.2.

7.3 Demodulation of DCH in Multi-path Fading Propagation conditions

7.3.1 Single Link Performance

7.3.1.1 Definition and applicability

The receive characteristics of the Dedicated Channel (DCH) in different multi-path fading environments are determined by the Block Error Ratio (BLER) values. BLER is measured for the each of the individual data rate specified for the DPCH. DCH is mapped into in Dedicated Physical Channel (DPCH).

The UE shall be tested only according to the data rate, supported. The data-rate-corresponding requirements shall apply to the UE.

7.3.1.2 Conformance requirements

For the parameters specified in Table 7.3.1.1, 7.3.1.3, 7.1.3.5 and 7.1.3.7 the average downlink $\frac{DPCH_{Ec}}{I_{or}}$ power shall be below the specified value for the BLER shown in Table 7.3.1.2, 7.3.1.4, 7.3.1.6 and 7.3.1.8. These requirements are applicable for TFCS size 16.

Table 7.3.1.1: DCH parameters in multi-path fading propagation conditions (Case 1)

Parameter	Test 1	Test 2	Test 3	Test 4	Unit
Phase reference	P-CPICH				
\hat{I}_{or}/I_{oc}	9				dB
I_{oc}	-60				dBm / 3.84 MHz
Information Data Rate	12.2	64	144	384	kbps

Table 7.3.1.2: DCH requirements in multi-path fading propagation conditions (Case 1)

Test Number	$\frac{DPCH_E_c}{I_{or}}$	BLER
1	-15.0 dB	10^{-2}
2	-13.9 dB	10^{-1}
	-10.0 dB	10^{-2}
3	-10.6 dB	10^{-1}
	-6.8 dB	10^{-2}
4	-6.3 dB	10^{-1}
	-2.2 dB	10^{-2}

Table 7.3.1.3: DCH parameters in multi-path fading propagation conditions (Case 2)

Parameter	Test 5	Test 6	Test 7	Test 8	Unit
Phase reference	P-CPICH				
\hat{I}_{or}/I_{oc}	-3	-3	3	6	dB
I_{oc}	-60				dBm / 3.84 MHz
Information Data Rate	12.2	64	144	384	kbps

Table 7.3.1.4: DCH requirements in multi-path fading propagation conditions (Case 2)

Test Number	$\frac{DPCH_E_c}{I_{or}}$	BLER
5	-7.7 dB	10^{-2}
6	-6.4 dB	10^{-1}
	-2.7 dB	10^{-2}
7	-8.1 dB	10^{-1}
	-5.1 dB	10^{-2}
8	-5.5 dB	10^{-1}
	-3.2 dB	10^{-2}

Table 7.3.1.5: DCH parameters in multi-path fading propagation conditions (Case 3)

Parameter	Test 9	Test 10	Test 11	Test 12	Unit
Phase reference	P-CPICH				
\hat{I}_{or}/I_{oc}	-3	-3	3	6	dB
I_{oc}	-60				dBm / 3.84 MHz
Information Data Rate	12.2	64	144	384	kbps

Table 7.3.1.6: DCH requirements in multi-path fading propagation conditions (Case 3)

Test Number	$\frac{DPCH_E_c}{I_{or}}$	BLER
9	-11.8 dB	10^{-2}
10	-8.1 dB	10^{-1}
	-7.4 dB	10^{-2}
	-6.8 dB	10^{-3}
11	-9.0 dB	10^{-1}
	-8.5 dB	10^{-2}
	-8.0 dB	10^{-3}
12	-5.9 dB	10^{-1}
	-5.1 dB	10^{-2}
	-4.4 dB	10^{-3}

Table 7.3.1.7: DCH parameters in multi-path fading propagation conditions (Case 1) with S-CPICH

Parameter	Test 13	Test 14	Test 15	Test 16	Unit
Phase reference	S-CPICH				
\hat{I}_{or}/I_{oc}	9				dB
I_{oc}	-60				dBm / 3.84 MHz
Information Data Rate	12.2	64	144	384	kbps

Table 7.3.1.8: DCH requirements in multi-path fading propagation conditions (Case 1) with S-CPICH

Test Number	$\frac{DPCH_E_c}{I_{or}}$	BLER
13	-15.0 dB	10^{-2}
14	-13.9 dB	10^{-1}
	-10.0 dB	10^{-2}
15	-10.6 dB	10^{-1}
	-6.8 dB	10^{-2}
16	-6.3 dB	10^{-1}
	-2.2 dB	10^{-2}

The reference for this requirement is [1] TS 25.101 subclause 8.3.1.1.

7.3.1.3 Test purpose

To verify the ability of the receiver to receive a predefined test signal, representing a multi-path fading propagation channel for the wanted and for the co-channel signals from serving and adjacent cells, with a BLER not exceeding a specified value.

7.3.1.4 Method of test

7.3.1.4.1 Initial conditions

1. Connect the SS, multi-path fading simulator and an AWGN noise source to the UE antenna connector as shown in Figure A.10.
2. Set up a call according to the Generic call setup procedure.
3. Set the test parameters for test 1-15 as specified Table 7.3.1.1, Table 7.3.1.3, Table 7.3.1.5 and Table 7.3.1.7.
4. Enter the UE into loopback test mode and start the loopback test.
5. Setup fading simulators as fading condition case 1 to 3 which are described in Table D.2.2.1

7.3.1.4.2 Procedures

1. Measure BLER of DCH.

7.3.1.5 Test requirements

For the parameters specified in Table 7.3.1.1, Table 7.3.1.3, Table 7.3.1.5 and Table 7.3.1.7 the BLER shall not exceed the value at the $DPCH_Ec/I_{or}$ specified in Table 7.3.1.2, Table 7.3.1.4, Table 7.3.1.6 and Table 7.3.1.8.

7.4 Demodulation of DCH in Moving Propagation conditions

7.4.1 Single Link Performance

7.4.1.1 Definition and applicability

The receive single link performance of the Dedicated Channel (DCH) in dynamic moving propagation conditions are determined by the Block Error Ratio (BLER) values. BLER is measured for the each of the individual data rate specified for the DPCH. DCH is mapped into Dedicated Physical Channel (DPCH).

The UE shall be tested only according to the data rate, supported. The data-rate-corresponding requirements shall apply to the UE.

7.4.1.2 Conformance requirements

For the parameters specified in Table 7.4.1.1 the average downlink $\frac{DPCH_Ec}{I_{or}}$ power shall be below the specified value for the BLER shown in Table 7.4.1.2.

Table 7.4.1.1: DCH parameters in moving propagation conditions

Parameter	Test 1	Test 2	Unit
Phase reference	P-CPICH		
\hat{I}_{or}/I_{oc}	-1		dB
I_{oc}	-60		dBm / 3.84 MHz
Information Data Rate	12.2	64	kbps

Table 7.4.1.2: DCH requirements in moving propagation conditions

Test Number	$\frac{DPCH_Ec}{I_{or}}$	BLER
1	-14.5 dB	10^{-2}
2	-10.9 dB	10^{-2}

The reference for this requirement is [1] TS 25.101 subclause 8.4.1.1.

7.4.1.3 Test purpose

To verify the ability of the receiver to receive a predefined test signal, representing a moving propagation channel for the wanted and for the co-channel signals from serving and adjacent cells, with a BLER not exceeding a specified value.

7.4.1.4 Method of test

7.4.1.4.1 Initial conditions

1. Connect the SS and an AWGN noise source to the UE antenna connector as shown in Figure A.10.
2. Set up a call according to the Generic call setup procedure.
3. Set the test parameters as specified in Table 7.4.1.1.
4. Enter the UE into loopback test mode and start the loopback test.
5. Setup fading simulator as moving propagation condition, which is described in clause D.2.3.

7.4.1.4.2 Procedures

1. Measure BLER of DCH.

7.4.1.5 Test requirements

For the parameters specified in Table 7.4.1.1 the BLER shall not exceed the value at the $DPCH_Ec/I_{or}$ specified in Table 7.4.1.2.

7.5 Demodulation of DCH in Birth-Death Propagation conditions

7.5.1 Single Link Performance

7.5.1.1 Definition and applicability

The receive single link performance of the Dedicated Channel (DCH) in dynamic birth-death propagation conditions are determined by the Block Error Ratio (BLER) values. BLER is measured for the each of the individual data rate specified for the DPCH. DCH is mapped into Dedicated Physical Channel (DPCH).

The UE shall be tested only according to the data rate, supported. The data-rate-corresponding requirements shall apply to the UE.

7.5.1.2 Conformance requirements

For the parameters specified in Table 7.5.1.1 the average downlink $\frac{DPCH_Ec}{I_{or}}$ power shall be below the specified value for the BLER shown in Table 7.5.1.2.

Table 7.5.1.1: DCH parameters in birth-death propagation conditions

Parameter	Test 1	Test 2	Unit
Phase reference	P-CPICH		
\hat{I}_{or}/I_{oc}	-1		dB
I_{oc}	-60		dBm / 3.84 MHz
Information Data Rate	12.2	64	kbps

Table 7.5.1.2: DCH requirements in birth-death propagation conditions

Test Number	$\frac{DPCH_E_c}{I_{or}}$	BLER
1	-12.6 dB	10^{-2}
2	-8.7 dB	10^{-2}

The reference for this requirement is [1] TS 25.101 subclause 8.5.1.1.

7.5.1.3 Test purpose

To verify the ability of the receiver to receive a predefined test signal, representing a birth-death propagation channel for the wanted and for the co-channel signals from serving and adjacent cells, with a BLER not exceeding a specified value.

7.5.1.4 Method of test

7.5.1.4.1 Initial conditions

1. Connect the SS and an AWGN noise source to the UE antenna connector as shown in Figure A.10.
2. Set up a call according to the Generic call setup procedure.
3. Set the test parameters as specified in Table 7.5.1.1.
4. Enter the UE into loopback test mode and start the loopback test.
5. Setup fading simulator as birth-death propagation condition, which is described in clause D.2.4.

7.5.1.4.2 Procedures

1. Measure BLER of DCH.

7.5.1.5 Test requirements

For the parameters specified in Table 7.5.1.1 the BLER shall not exceed the value at the $DPCH_E_c/I_{or}$ specified in Table 7.5.1.2.

7.6 Demodulation of DCH in Base Station Transmit diversity modes

7.6.1 Demodulation of DCH in open-loop transmit diversity mode

7.6.1.1 Definition and applicability

The receive characteristic of the Dedicated Channel (DCH) in open loop transmit diversity mode is determined by the Block Error Ratio (BLER). DCH is mapped into in Dedicated Physical Channel (DPCH).

The requirements and this test apply to all types of UTRA for the FDD UE.

7.6.1.2 Conformance requirements

For the parameters specified in Table 7.6.1.1 the average downlink $\frac{DPCH_E_c}{I_{or}}$ power shall be below the specified value for the BLER shown in Table 7.6.1.2.

Table 7.6.1.1: Test parameters for DCH reception in a open-loop transmit diversity scheme (Propagation condition: Case 1)

Parameter	Test 1	Unit
Phase reference	P-CPICH	
\hat{I}_{or}/I_{oc}	9	dB
I_{oc}	-60	dBm / 3.84 MHz
Information data rate	12.2	kbps

Table 7.6.1.2: Test requirements for DCH reception in open-loop transmit diversity scheme

Test Number	$\frac{DPCH_E_c}{I_{or}}$ (antenna 1/2)	BLER
1	[-16.8 dB]	10^{-2}

The reference for this requirement is [1] TS 25.101 subclause 8.6.1.1.

7.6.1.3 Test purpose

To verify that UE reliably demodulates the DPCH of the Node B while open loop transmit diversity is enabled during the connection.

7.6.1.4 Method of test

7.6.1.4.1 Initial conditions

- 1) Connect SS, multi-path fading simulators and an AWGN source to the UE antenna connector as shown in Figure A.12.
- 2) Set up a call according to the Generic call setup procedure.
- 3) RF parameters are set up according to Table 7.6.1.1 and Table E 3.4.
- 4) Enter the UE into loopback test mode and start the loopback test.
- 5) Activate open loop Tx diversity function.
- 6) Set up fading simulators as fading condition case 1, which is described in Table D.2.2.1.

See [3] TS 34.108 and [4] TS 34.109 for details regarding generic call setup procedure and loopback test.

7.6.1.4.2 Procedure

- 1) Measure BLER in points specified in Table 7.6.1.2.

7.6.1.5 Test Requirements

For the parameters specified in Table 7.6.1.1 the BLER shall not exceed the value at the $DPCH_E_c/I_{or}$ specified in Table 7.6.1.2.

7.6.2 Demodulation of DCH in closed loop transmit diversity mode

7.6.2.1 Definition and applicability

The receive characteristic of the dedicated channel (DCH) in closed loop transmit diversity mode is determined by the Block Error Ratio (BLER). DCH is mapped into in Dedicated Physical Channel (DPCH).

The requirements and this test apply to all types of UTRA for the FDD UE.

7.6.2.2 Conformance requirements

For the parameters specified in Table 7.6.2.1 the average downlink $\frac{DPCH_E_c}{I_{or}}$ power shall be below the specified value for the BLER shown in Table 7.6.2.2.

Table 7.6.2.1: Test Parameters for DCH Reception in closed loop transmit diversity mode (Propagation condition: Case 1)

Parameter	Test 1 (Mode 1)	Test 2 (Mode 2)	Unit
\hat{I}_{or}/I_{oc}	9	9	dB
I_{oc}	-60	-60	dBm / 3.84 MHz
Information data rate	12.2	12.2	kbps
Feedback error ratio	4	4	%

Table 7.6.2.2: Test requirements for DCH reception in feedback transmit diversity mode

Test Number	$\frac{DPCH_E_c}{I_{or}}$ (see note)	BLER
1	-18.0 dB	10^{-2}
2	-18.3 dB	10^{-2}
Note: This is the total power from both antennas. Power sharing between antennas are closed loop mode dependent as specified in TS25.214.		

The reference for this requirement is [1] TS 25.101 subclause 8.6.2.1.

7.6.2.3 Test purpose

To verify that UE reliably demodulates the DPCH of the Node B while closed loop transmit diversity is enabled during the connection.

7.6.2.4 Method of test

7.6.2.4.1 Initial conditions

- 1) Connect SS, multi-path fading simulators and an AWGN source to the UE antenna connector as shown in Figure A.12.
- 2) Set up a call according to the Generic call setup procedure.
- 3) RF parameters are set up according to Table 7.6.2.1 and Table E 3.5.
- 4) Enter the UE into loopback test mode and start the loopback test.
- 5) Activate closed loop Tx diversity function.
- 6) Set up fading simulators as fading condition case 1, which is described in Table D.2.2.1.

See [3] TS 34.108 and [4] TS 34.109 for details regarding generic call setup procedure and loopback test.

7.6.2.4.2 Procedure

- 1) Measure BLER in points specified in Table 7.6.2.2.

7.6.2.5 Test Requirements

For the parameters specified in Table 7.6.2.1 the BLER shall not exceed the value at the DPCH_Ec/Ior specified in Table 7.6.2.2.

7.6.3 Demodulation of DCH in Site Selection Diversity Transmission Power Control mode

7.6.3.1 Definition and applicability

The bit error characteristics of UE receiver is determined in Site Selection Diversity Transmission Power Control (SSDT) mode. Two Node B emulators are required for this performance test. The delay profiles of signals received from different base stations are assumed to be the same but time shifted by 10 chip periods.

The requirements and this test apply to all types of UTRA for the FDD UE.

7.6.3.2 Conformance requirements

The downlink physical channels and their relative power to Ior are the same as those specified in clause E.3.3 irrespective of Node Bs and the test cases. DPCH_Ec/Ior value applies whenever DPDCH in the cell is transmitted. In Test 1 and Test 3, the received powers at UE from two Node Bs are the same, while 3dB offset is given to one that comes from one of Node Bs for Test 2 and Test 4 as specified in Table 7.6.3.1.

For the parameters specified in Table 7.6.3.1 the average downlink $\frac{DPCH_Ec}{I_{or}}$ power shall be below the specified value for the BLER shown in Table 7.6.3.2.

Table 7.6.3.1: DCH parameters in multi-path propagation conditions during SSDT mode (Propagation condition: Case 1)

Parameter	Test 1	Test 2	Test 3	Test 4	Unit
Phase reference	P-CPICH				
\hat{I}_{or1}/I_{oc}	0	-3	0	0	dB
\hat{I}_{or2}/I_{oc}	0	0	0	-3	dB
I_{oc}	-60				dBm / 3.84 MHz
Information Data Rate	12.2	12.2	12.2	12.2	kbps
Feedback error rate*	4	4	4	4	%
Number of FBI bits assigned to "S" Field	1	1	2	2	
Code word Set	Long	Long	Short	Short	

*NOTE: Feedback error rate is defined as FBI bit error rate.

Table 7.6.3.2: DCH requirements in multi-path propagation conditions during SSDT Mode

Test Number	$\frac{DPCH_E_c}{I_{or}}$	BLER
1	-7.5 dB	10^{-2}
2	-6.5 dB	10^{-2}
3	-10.5 dB	10^{-2}
4	-9.2 dB	10^{-2}

The reference for this requirement is [1] TS 25.101 subclause 8.6.3.1.

7.6.3.3 Test purpose

To verify that UE reliably demodulates the DPCH of the selected Node B while site selection diversity is enabled during soft handover.

7.6.3.4 Method of test

7.6.3.4.1 Initial conditions

- 1) Connect two SS's, multi-path fading simulators and an AWGN source to the UE antenna connector as shown in Figure A.11.
- 2) Set up a call according to the Generic call setup procedure, and RF parameters are set up according to Table 7.6.3.1 and Table 7.6.3.2.
- 3) Enter the UE into loopback test mode and start the loopback test.
- 4) Activate SSDT function.
- 5) Set up fading simulators as fading condition case 1, which is described in Table D.2.2.1.

7.6.3.4.2 Procedure

Measure BLER in points specified in Table 7.6.3.2..

7.6.3.5 Test Requirements

BLER shall not exceed the value at the $DPCH_E_c/I_{or}$ specified in Table 7.6.3.2.

7.7 Demodulation in Handover conditions

7.7.1 Demodulation of DCH in Inter-Cell Soft Handover

7.7.1.1 Definition and applicability

The bit error ratio characteristics of UE is determined during an inter-cell soft handover. During the soft handover a UE receives signals from different Base Stations. A UE has to be able to demodulate two P-CCPCH channels and to combine the energy of DCH channels. Delay profiles of signals received from different Base Stations are assumed to be the same but time shifted by 10 chips.

The receive characteristics of the different channels during inter-cell handover are determined by the Block Error Ratio (BLER) values.

The UE shall be tested only according to the data rate, supported. The data-rate-corresponding requirements shall apply to the UE.

7.7.1.2 Conformance requirements

For the parameters specified in Table 7.7.1.1 the average downlink $\frac{DPCH_E_c}{I_{or}}$ power shall be below the specified value for the BLER shown in Table 7.7.1.2.

Table 7.7.1.1: DCH parameters in multi-path propagation conditions during Soft Handoff (Case 3)

Parameter	Test 1	Test 2	Test 3	Test 4	Unit
Phase reference	P-CPICH				
\hat{I}_{or1}/I_{oc} and \hat{I}_{or2}/I_{oc}	0	0	3	6	dB
I_{oc}	-60				dBm / 3.84 MHz
Information Data Rate	12.2	64	144	384	kbps

Table 7.7.1.2: DCH requirements in multi-path propagation conditions during Soft Handoff (Case 3)

Test Number	$\frac{DPCH_E_c}{I_{or}}$	BLER
1	-15.2 dB	10^{-2}
2	-11.8 dB	10^{-1}
	-11.3 dB	10^{-2}
3	-9.6 dB	10^{-1}
	-9.2 dB	10^{-2}
4	-6.0 dB	10^{-1}
	-5.5 dB	10^{-2}

The reference for this requirement is [1] TS 25.101 subclause 8.7.1.1.

7.7.1.3 Test purpose

To verify that the BLER does not exceed the value at the $DPCH_E_c/I_{or}$ specified in Table 7.7.1.2.

7.7.1.4 Method of test

7.7.1.4.1 Initial conditions

[TBD]

7.7.1.4.2 Procedures

- 1) Connect the SS, multi-path fading simulator and an AWGN noise source to the UE antenna connector as shown in Figure A.11.
- 2) Set up the call.
- 3) Set the test parameters for test 1-5 as specified in Table 7.7.1.1.
- 4) Count, at the SS, the number of information blocks transmitted and the number of correctly received information blocks at the UE.
- 5) Measure BLER of DCH channel.

7.7.1.5 Test requirements

For the parameters specified in Table 7.7.1.1 the BLER shall not exceed the value at the DPCH_Ec/Ior specified in Table 7.7.1.2.

7.7.2 Combining of TPC commands from radio links of different radio link sets

7.7.2.1 Definition and applicability

When a UE is in soft handover, multiple TPC commands may be received in each slot from different cells in the active set. In general, the TPC commands transmitted in the same slot in the different cells may be different and need to be combined to give TPC_cmd as specified in [5] TS25.214, in order to determine the required uplink power step.

The requirements and this test apply to all types of UTRA for the FDD UE.

7.7.2.2 Conformance requirements

Test parameters are specified in Table 7.7.2.1. The delay profiles of the signals received from the different cells are the same but time-shifted by 10 chips.

For Test 1, the uplink power changes between adjacent slots shall be as shown in Table 7.7.2.2 over the 4 consecutive slots. Note that this case is without an additional noise source I_{oc} .

For Test 2, the Cell1 and Cell2 TPC patterns are repeated a number of times. If the transmitted power of a given slot is increased compared to the previous slot, then a variable "Transmitted power UP" is increased by one, otherwise a variable "Transmitted power DOWN" is increased by one. The requirements for "Transmitted power UP" and "Transmitted power DOWN" are shown in Table 7.7.2.3.

Table 7.7.2.1: Parameters for TPC command combining

Parameter	Test 1	Test 2	Unit
Phase reference	P-CPICH		-
DPCH_Ec/Ior	-12		dB
\hat{I}_{or1} and \hat{I}_{or2}	-60		dBm / 3.84 MHz
I_{oc}	-	-60	dBm / 3.84 MHz
Power-Control-Algorithm	Algorithm 1		-
Cell 1 TPC commands over 4 slots	{0,0,1,1}		-
Cell 2 TPC commands over 4 slots	{0,1,0,1}		-
Information Data Rate	12.2		Kbps
Propagation condition	Static without AWGN source I_{oc}	Multi-path fading case 3	-

Table 7.7.2.2: Requirements for Test 1

Test Number	Required power changes over the 4 consecutive slots
1	Down, Down, Down, Up

Table 7.7.2.3: Requirements for Test 2

Test Number	Ratio (Transmitted power UP) / (Total number of slots)	Ratio (Transmitted power DOWN) / (Total number of slots)
2	≥ 0.25	≥ 0.5

The reference for this requirement is [1] TS 25.101 subclause 8.7.2.1.

7.7.2.3 Test purpose

To verify that the combining of TPC commands received in soft handover results in TPC_cmd being derived so as to meet the requirements stated in Tables 7.7.2.2 and 7.7.2.3.

7.7.2.4 Method of test

7.7.2.4.1 Initial conditions

- 1) Connect two SS's to the UE antenna connector as shown in Figure A.13.
- 2) Set the test parameters as specified in Table 7.7.2.1 for Test 1.
- 3) Set up a call according to the Generic Call Setup procedure.
- 4) Signal the uplink DPCH power control parameters to use Algorithm 1 and a step size of 1dB.
- 5) Enter the UE into loopback test mode and start the loopback test.

See [3] TS 34.108 and [4] TS 34.109 for details regarding the generic call setup procedure and loopback test.

7.7.2.4.2 Procedures

- 1) Before proceeding with paragraph (2), set the output power of the UE, measured at the UE antenna connector, to be in the range -10 ± 9 dBm. This may be achieved by setting the downlink signal (\hat{I}_{or}) to yield an appropriate open loop output power and/or by generating suitable downlink TPC commands from the SSs.
- 2) Send the following sequences of TPC commands in the downlink from each SS over a period of 5 timeslots:

	Downlink TPC commands				
	Slot #0	Slot #1	Slot #2	Slot #3	Slot #4
SS1	0	0	0	1	1
SS2	0	0	1	0	1

- 3) Measure the average output power at the UE antenna connector in timeslots # 0, 1, 2, 3 and 4, not including the 25 μ s transient periods at the start and end of each slot.
- 4) End test 1 and disconnect UE.
- 5) Connect two SS's and an AWGN source to the UE antenna connector as shown in Figure A.11.
- 6) Initialise variables "Transmitted power UP" and "Transmitted power DOWN" to zero.
- 7) Set the test parameters as specified in Table 7.7.2.1 for Test 2.
- 8) Set up a call according to the Generic Call Setup procedure.
- 9) Signal the uplink DPCH power control parameters to use Algorithm 1 and a step size of 1dB.
- 10) Enter the UE into loopback test mode and start the loopback test.
- 11) Perform the following steps a) to d) [15] times:

- a) Before proceeding with step b), set the output power of the UE, measured at the UE antenna connector, to be in the range -10 ± 9 dBm. This may be achieved by generating suitable downlink TPC commands from the SSs.
- b) Send the following sequences of TPC commands in the downlink from each SS over a period of 33 timeslots:

	Downlink TPC commands
SS1	1 0 0 1 1 0 0 1 1 0 0 1 1 0 0 1 1 0 0 1 1 0 0 1 1 0 0 1 1 0 0 1 1
SS2	1 0 1 0 1 0 1 0 1 0 1 0 1 0 1 0 1 0 1 0 1 0 1 0 1 0 1 0 1 0 1 0 1 0 1 0 1 0 1

- c) Measure the average output power at the UE antenna connector in each timeslot, not including the 25μ s transient periods at the start and end of each slot.
- d) For each timeslot from the 2nd timeslot to the 33rd timeslot inclusive:
 - if the average power in that timeslot is greater than or equal to the average power in the previous timeslot plus 0.5dB, increment “Transmitted power UP” by 1;
 - if the average power in that timeslot is less than or equal to the average power in the previous timeslot minus 0.5dB, increment “Transmitted power DOWN” by 1.

7.7.2.5 Test requirements

- 1) In Step 2) of subclause 7.7.2.4.2, the average power in slot #1 shall be less than or equal to the average power in slot #0 minus 0.5dB.
- 2) In Step 2) of subclause 7.7.2.4.2, the average power in slot #2 shall be less than or equal to the average power in slot #1 minus 0.5dB.
- 3) In Step 2) of subclause 7.7.2.4.2, the average power in slot #3 shall be less than or equal to the average power in slot #2 minus 0.5dB.
- 4) In Step 2) of subclause 7.7.2.4.2, the average power in slot #4 shall be greater than or equal to the average power in slot #3 plus 0.5dB.
- 5) At the end of the test, "Transmitted power UP" shall be greater than or equal to [95] and "Transmitted power DOWN" shall be greater than or equal to [210].

NOTE: The test limits in requirements (4) and (5) have been computed to give a confidence level of [99.7]% that a UE which follows the core requirements will pass. The number of timeslots has been chosen to get a good compromise between the test time and the risk of passing a bad UE.

7.8 Power control in downlink

Power control in the downlink is the ability of the UE receiver to converge to required link quality set by the network while using as low power as possible in downlink. If a BLER target has been assigned to a DCCH (See Annex C.3), then it has to be such that outer loop is based on DTCH and not on DCCH.

7.8.1 Power control in the downlink, constant BLER target

7.8.1.1 Definition and applicability

Power control in the downlink is the ability of the UE receiver to converge to required link quality set by the network while using as low power as possible in downlink. If a BLER target has been assigned to a DCCH (See Annex C.3), then it has to be such that outer loop is based on DTCH and not on DCCH. The requirements and this test apply to all types of UTRA for the FDD UE.

7.8.1.2 Conformance requirements

For the parameters specified in Table 7.8.1.1 the downlink $\frac{DPCH_E_c}{I_{or}}$ power measured values, which are averaged over one slot, shall be below the specified value in Table 7.8.1.2 more than 90% of the time. BLER shall be as shown in Table 7.8.1.2. Power control in downlink is ON during the test.

Table 7.8.1.1: Test parameter for downlink power control, constant BLER target

Parameter	Test 1	Test 2	Unit
\hat{I}_{or}/I_{oc}	9	-1	dB
I_{oc}	-60		dBm / 3.84 MHz
Information Data Rate	12.2		kbps
Target quality on DTCH	0.01		BLER
Propagation condition	Case 4		
Maximum_DL_Power *	7		dB
Minimum_DL_Power *	-18		dB
Limited_Power_Raise_Used	"Not used"		-

Note *: Power is compared to P-CPICH as specified in [9].

Table 7.8.1.2: Requirements in downlink power control, constant BLER target

Parameter	Test 1	Test 2	Unit
$\frac{DPCH_E_c}{I_{or}}$	-16.0	-9.0	dB
Measured quality on DTCH	0.01±30%	0.01±30%	BLER

The reference for this requirement is [1] TS 25.101 subclause 8.8.1.1.

7.8.1.3 Test purpose

To verify that the UE receiver is capable of converging to required link quality set by network while using as low power as possible.

7.8.1.4 Method of test

7.8.1.4.1 Initial conditions

- 1) Connect SS, multipath fading simulator and an AWGN source to the UE antenna connector as shown in Figure A.10.
- 2) Set up a call according to the Generic call setup procedure.
- 3) RF parameters are set up according to Table 7.8.1.1.
- 4) Enter the UE into loopback test mode and start the loopback test.
- 5) SS signals to UE target quality value on DTCH as specified in Table 7.8.1.1. SS will vary the physical channel power in downlink according to the TPC commands from UE. SS response time for UE TPC commands shall be one slot. At the same time BLER is measured. This is continued until the target quality value on DTCH is met, within the minimum accuracy requirement.

See [3] TS 34.108 and [4] TS 34.109 for details regarding generic call setup procedure and loopback test.

7.8.1.4.2 Procedure

- 1) After the target quality on DTCH is met, BLER is measured. Simultaneously the downlink $\frac{DPCH - E_c}{I_{or}}$ power averaged over one slot is measured. This is repeated until adequate amount of measurements is done to reach the required confidence level.
- 2) The measured quality on DTCH (BLER) and the measured downlink $\frac{DPCH - E_c}{I_{or}}$ power values averaged over one slot are compared to limits in Table 7.8.1.2.

7.8.1.5 Test Requirements

- a) The measured quality on DTCH does not exceed the values in Table 7.8.1.2.
- b) The downlink $\frac{DPCH - E_c}{I_{or}}$ power values, which are averaged over one slot, shall be below the values in Table 7.8.1.2 more than 90% of the time.

7.8.2 Power control in the downlink, initial convergence

7.8.2.1 Definition and applicability

This requirement verifies that DL power control works properly during the first seconds after DPCH connection is established. The requirements and this test apply to all types of UTRA for the FDD UE.

7.8.2.2 Conformance requirements

For the parameters specified in Table 7.8.2.1 the downlink DPCH_Ec/Ior power measured values, which are averaged over [50 ms], shall be within the range specified in Table 7.8.2.2 more than 90% of the time. T1 equals to [500 ms] and it starts [10 ms] after the DPDCH connection is initiated. T2 equals to [500 ms] and it starts when T1 has expired. Power control is ON during the test.

Table 7.8.2.1: Test parameters for downlink power control, initial convergence

Parameter	Test 1	Test 2	Test 3	Test 4	Unit
Target quality value on DTCH	0.01	0.01	0.1	0.1	BLER
Initial DPCH_Ec/Ior	-5.9	-25.9	-2.1	-22.1	dB
Information Data Rate	12.2	12.2	64	64	kbps
\hat{I}_{or}/I_{oc}	-1				dB
I_{oc}	-60				dBm/3.84 MHz
Propagation condition	[Static]				
Maximum_DL_Power *	7				dB
Minimum_DL_Power *	-18				dB
Limited_Power_Raise_Used	"Not used"				

Note *: Power is compared to P-CPICH as specified in [9]

Table 7.8.2.2: Requirements in downlink power control, initial convergence

Parameter	Test 1 and Test 2	Test 3 and Test 4	Unit
$\frac{DPCH - E_c}{I_{or}}$ during T1	$[-18.9 \leq DPCH_Ec/lor \leq -11.9]$	$[-15.1 \leq DPCH_Ec/lor \leq -8.1]$	dB
$\frac{DPCH - E_c}{I_{or}}$ during T2	$[-18.9 \leq DPCH_Ec/lor \leq -14.9]$	$[-15.1 \leq DPCH_Ec/lor \leq -11.1]$	dB

The reference for this requirement is [1] TS 25.101 subclause 8.8.2.1.

7.8.2.3 Test purpose

To verify that DL power control works properly during the first seconds after DPCH connection is established.

7.8.2.4 Method of test

7.8.2.4.1 Initial conditions

- 1) Connect SS, multipath fading simulator and an AWGN source to the UE antenna connector as shown in Figure A.10.

7.8.2.4.2 Procedure

- 1) Set up call using test parameters according to Table 7.8.2.1.
- 2) Measure $\frac{DPCH - E_c}{I_{or}}$ power averaged over [50 ms] during T1. T1 starts [10 ms] after DPCH connection is initiated and T1 equals to [500 ms]
- 3) Measure $\frac{DPCH - E_c}{I_{or}}$ power averaged over [50 ms] during T2. T2 starts, when T1 has expired and T2 equals to [500 ms]

7.8.2.5 Test Requirements

- a) The downlink $\frac{DPCH - E_c}{I_{or}}$ power values shall be within the range specified in Table 7.8.2.2 during T1 more than 90% of the time.
- b) The downlink $\frac{DPCH - E_c}{I_{or}}$ power values shall be within the range specified in Table 7.8.2.2 during T2 more than 90% of the time.

7.8.3 Power control in the downlink, wind up effects

7.8.3.1 Definition and applicability

This requirement verifies that, after the downlink maximum power is limited in the UTRAN and it has been released again, the downlink power control in the UE does not have a wind up effect, i.e. the required DL power has increased during time period the DL power was limited. The requirements and this test apply to all types of UTRA for the FDD UE.

7.8.3.2 Conformance requirements

This test is run in three stages where stage 1 is for convergence of the power control loop, in stage two the maximum downlink power for the dedicated channel is limited not to be higher than the parameter specified in Table 7.8.3.1. All parameters used in the three stages are specified in Table 7.8.3.1. The downlink $\frac{DPCH_E_c}{I_{or}}$ power measured values,

which are averaged over one slot, during stage 3 shall be lower than the value specified in Table 7.8.3.2 more than 90% of the time. Power control of the UE is ON during the test.

Table 7.8.3.1: Test parameter for downlink power control, wind-up effects

Parameter	Test 1			Unit
	Stage 1	Stage 2	Stage 3	
Time in each stage	>15	5	0.5	s
\hat{I}_{or}/I_{oc}	5			dB
I_{oc}	-60			dBm/3.84 MHz
Information Data Rate	12.2			kbps
Quality target on DTCH	0.01			BLER
Propagation condition	Case 4			
Maximum_DL_Power *	7	-6.2	7	dB
Minimum_DL_Power *	-18			dB
Limited_Power_Raise_Used	"Not used"			-

Note *: Power is compared to P-CPICH as specified in [9]

Table 7.8.3.2: Requirements in downlink power control, wind-up effects

Parameter	Test 1, stage 3	Unit
$\frac{DPCH_E_c}{I_{or}}$	[-13.3]	dB

The reference for this requirement is [1] TS 25.101 subclause 8.8.3.1.

7.8.3.3 Test purpose

To verify that the UE downlink power control does not require too high downlink power during a period after the downlink power is limited by the UTRAN.

7.8.3.4 Method of test

7.8.3.4.1 Initial conditions

- 1) Connect SS, multipath fading simulator and an AWGN source to the UE antenna connector as shown in Figure A.10.
- 2) Set up a call according to the Generic call setup procedure.
- 3) Enter the UE into loopback test mode and start the loopback test.

- 4) RF parameters are set up according to Table 7.8.3.1. Stage 1 is used for the power control to converge and during Stage 2 the maximum downlink power is limited by UTRAN.

See [3] TS 34.108 and [4] TS 34.109 for details regarding generic call setup procedure and loopback test.

7.8.3.4.2 Procedure

- 1) Measure $\frac{DPCH - E_c}{I_{or}}$ power during stage 3 according to Table 7.8.3.1.

7.8.3.5 Test Requirements

The downlink $\frac{DPCH - E_c}{I_{or}}$ power values, which are averaged over one slot, shall be lower than the level specified in table 7.8.3.2 during stage 3 more than 90% of the time.

7.9 Downlink compressed mode

Downlink compressed mode is used to create gaps in the downlink transmission, to allow the UE to make measurements on other frequencies.

7.9.1 Single link performance

7.9.1.1 Definition and applicability

The receiver single link performance of the Dedicated Traffic Channel (DCH) in compressed mode is determined by the Block Error Ratio (BLER) and transmitted DPCH_Ec/Ior power in the downlink.

The compressed mode parameters are given in clause C.5. Tests 1 and 2 are using Set 1 compressed mode pattern parameters from Table C.5.1 in clause C.5 while tests 3 and 4 are using Set 2 compressed mode patterns from the same table.

The requirements and this test apply to all types of UTRA for the FDD UE.

7.9.1.2 Conformance requirements

For the parameters specified in Table 7.9.1 the downlink $\frac{DPCH - E_c}{I_{or}}$ power measured values, which are averaged over one slot, shall be below the specified value in Table 7.9.2 more than 90% of the time. The measured quality on DTCH shall be as required in Table 7.9.2.

Downlink power control is ON during the test. Uplink TPC commands shall be error free. System simulator shall increase the transmitted power during compressed frames by the same amount that UE is expected to increase its SIR target during those frames.

Table 7.9.1: Test parameter for downlink compressed mode

Parameter	Test 1	Test 2	Test 3	Test 4	Unit
Delta SIR1	0	3	0	3	dB
Delta SIR after1	0	3	0	3	dB
Delta SIR2	0	0	0	0	dB
Delta SIR after2	0	0	0	0	dB
\hat{I}_{or}/I_{oc}	9				dB
I_{oc}	-60				dBm / 3.84 MHz
Information Data Rate	12.2				kbps
Propagation condition	Case 2				
Target quality value on DTCH	0.01				BLER
Maximum DL Power *	7				dB
Minimum DL Power *	-18				dB
Limited Power Raise Used	"Not used"				-

Note *: Power is compared to P-CPICH as specified in [9].

Table 7.9.2: Requirements in downlink compressed mode

Parameter	Test 1	Test 2	Test 3	Test 4	Unit
$\frac{DPCH - E_c}{I_{or}}$	-14.8	No requirements	-15.4	No requirements	dB
Measured quality of compressed and recovery frames	No requirements	<0.001	No requirements	<0.001	BLER
Measured quality on DTCH	0.01 ± 30 %				BLER

The reference for this requirement is [1] TS 25.101 subclause 8.9.1.1.

7.9.1.3 Test purpose

The purpose of this test is to verify the reception of DPCH in a UE while downlink is in a compressed mode. The UE needs to preserve the BLER using sufficient low DL power. It is also verified that UE applies the Delta SIR values, which are signaled from network, in its outer loop power control algorithm.

7.9.1.4 Method of test

7.9.1.4.1 Initial conditions

- 1) Connect SS, multipath fading simulator and an AWGN source to the UE antenna connector as shown in Figure A.10.
- 2) Set up a call according to the Generic call setup procedure.
- 3) RF parameters are set up according to Table 7.9.1. SS shall increase the transmitted power during compressed mode frames by the same amount that UE is expected to increase its SIR target during those frames
- 4) Set compressed mode parameters according to Table C.5.1. Tests 1 and 2 are using Set 1 compressed mode pattern parameters and while tests 3 and 4 are using Set 2 compressed mode pattern parameters.
- 5) Enter the UE into loopback test mode and start the loopback test.
- 6) SS signals to UE target quality value on DTCH as specified in Table 7.9.1. Uplink TPC commands shall be error free. SS will vary the physical channel power in downlink according to the TPC commands from UE. SS response time for UE TPC commands shall be one slot. At the same time BLER is measured. This is continued until the target quality value on DTCH is met, within the minimum accuracy requirement.

See [3] TS 34.108 and [4] TS 34.109 for details regarding generic call setup procedure and loopback test.

7.9.1.4.2 Procedure

- 1) Test 1: Measure quality on DTCH and $\frac{DPCH_E_c}{I_{or}}$ power values averaged over one slot.
- 2) Test 2: Measure quality on DTCH and quality of compressed and recovery frames.
- 3) Test 3: Measure quality on DTCH and $\frac{DPCH_E_c}{I_{or}}$ power values averaged over one slot.
- 4) Test 4: Measure quality on DTCH and quality of compressed and recovery frames.

7.9.1.5 Test requirements

- a) Test 1: The downlink $\frac{DPCH_E_c}{I_{or}}$ power values averaged over one slot shall be below the values in Table 7.9.2 more than 90% of the time. The measured quality on DTCH shall be as required in Table 7.9.2.
- b) Test 2: Measured quality on DTCH and measured quality of compressed and recovery frames do not exceed the values in Table 7.9.2.
- c) Test3: The downlink $\frac{DPCH_E_c}{I_{or}}$ power values averaged over one slot shall be below the values in Table 7.9.2 more than 90% of the time. The measured quality on DTCH shall be as required in Table 7.9.2.
- d) Test 4: Measured quality on DTCH and measured quality of compressed and recovery frames do not exceed the values in Table 7.9.2.

7.10 Blind transport format detection

7.10.1 Definition and applicability

Performance of Blind transport format detection is determined by the Block Error Ratio (BLER) values and by the measured average transmitted DPCH_Ec/Ior value.

7.10.2 Conformance requirements

For the parameters specified in Table 7.10.1 the average downlink $\frac{DPCH_E_c}{I_{or}}$ power shall be below the specified value for the BLER and FDR shown in Table 7.10.2.

Table 7.10.1: Test parameters for Blind transport format detection

Parameter	Test 1	Test 2	Test 3	Test 4	Test 5	Test 6	Unit
\hat{I}_{or}/I_{oc}	-1			-3			dB
I_{oc}	-60						dBm / 3.84 MHz
Information Data Rate	12.2 (rate 1)	7.95 (rate 2)	1.95 (rate 3)	12.2 (rate 1)	7.95 (rate 2)	1.95 (rate 3)	kbps
propagation condition	static			multi-path fading case 3			-
TFCI	off						-

Table 7.10.2: The Requirements for DCH reception in Blind transport format detection

Test Number	$\frac{DPCH_E_c}{I_{or}}$	BLER	FDR
1	[-17.7dB]	10^{-2}	10^{-4}
2	[-17.8dB]	10^{-2}	10^{-4}
3	[-18.4dB]	10^{-2}	10^{-4}
4	[-13.0dB]	10^{-2}	10^{-4}
5	[-13.2dB]	10^{-2}	10^{-4}
6	[-13.8dB]	10^{-2}	10^{-4}

* The value of DPCH_Ec/I_{or}, I_{oc}, and I_{or}/I_{oc} are defined in case of DPCH is transmitted

Note: In the test, 9 different Transport Format Combinations (Table.7.10.3) are sent during the call set up procedure, so that UE has to detect correct transport format in this 9 candidates.

Table.7.10.3: Transport format combinations informed during the call set up procedure in the test

	1	2	3	4	5	6	7	8	9
DTCH	12.2k	10.2k	7.95k	7.4k	6.7k	5.9k	5.15k	4.75k	1.95k
DCCH					2.4k				

7.10.3 Test purpose

To verify the ability of the blind transport format detection to receive a predefined test signal, representing a static propagation channel for the wanted and for the co-channel signals from serving and adjacent cells, with a block error ratio (BLER) and false transport format detection ratio (FDR) not exceeding a specified value.

To verify the ability of the blind transport format detection to receive a predefined test signal, representing a multi-path propagation channel for the wanted and for the co-channel signals from serving and adjacent cells, with a block error ratio (BLER) and false transport format detection ratio (FDR) not exceeding a specified value.

7.10.4 Method of test

7.10.4.1 Initial conditions

1. Connect the SS and AWGN noise source to the UE antenna connector as shown in Figure A.9 in the case for test 1-3. Connect the SS, multipath fading simulator and an AWGN noise source to the UE antenna connector as shown in Figure A.10 in the case of test 4-6.
2. Set up a call according to the Generic call setup procedure.
3. Set the test parameters for test 1-6 as specified Table 7.10.1 and Table 7.10.2.
4. Enter the UE into loopback test mode and start the loopback test.
5. In the case of test 4-6, Setup fading simulator as fading condition case 3 which are described in Table D.2.2.1.

7.10.4.2 Procedure

Measure BLER and FDR of DCH.

7.10.5 Test requirements

BLER and FDR shall not exceed the values at the DPCH_Ec/I_{or} specified in Table 7.10.2.

8 Requirements for support of RRM

8.1 General

8.2 Idle Mode Tasks

8.2.1 Cell Selection

8.2.1.1 Cell Selection; the cells in the neighbour list belong to different frequencies

8.2.1.1.1 Definition and applicability

Test to verify that the UE is capable of selecting a suitable cell and camp on it within [X] seconds from switch on with stored information of the last registered PLMN. The stored information cell selection delay is then defined as the time the UE needs for sending the preamble for RRC Connection Request for Location Registration to UTRAN after the power has been switched on with a valid USIM and PIN is disabled. The test environment contains multiple cells.

This test is applicable for all UEs.

8.2.1.1.2 Conformance requirement

The stored information cell selection delay shall be equal or less than [X] seconds when the cells in the neighbour list belong to less than [3] frequencies. This shall be verified in more than [X%] of the cases with a confidence level of [Y%] [FFS].

The reference for this requirement is [2] TS 25.133 subclause 4.1.2.1.1 and A.4.1.1.2.

8.2.1.1.3 Test purpose

To verify that the UE meets the conformance requirement.

8.2.1.1.4 Method of test

8.2.1.1.4.1 Initial conditions

This scenario implies the presence of 2 carriers and 6 cells (3 cells per carrier) as given in Table 8.2.1 and 8.2.2.

The stored information of the last registered PLMN is used in this test. The stored information includes one of the UTRA RF CHANNEL NUMBERS used in the test. All the cells in the test are given in the measurement control information of each cell, which are on the RF carrier stored in the UE.

Table 8.2.1: General test parameters for Cell Selection in Multi carrier case

	Parameter	Unit	Value	Comment
Initial condition	Stored RF channel		Channel1	
	Neighbour cells of Cell1		Cell2, Cell3, Cell4, Cell5, Cell6	
	Neighbour cells of Cell2		Cell1, Cell3, Cell4, Cell5, Cell6	
	Neighbour cells of Cell3		Cell1, Cell2, Cell4, Cell5, Cell6	
Final condition	Active cell		Cell5	

The relative RF signal to total interference ratio at the UE ($CPICH_{Ec/Io}$) between the cells is shown in Table 8.2.2 and shall be:

Cell 5 > Cell 1 > Cell 2 > Cell 4 > Cell 3 > Cell 6

The absolute signal level of each cell can be obtained from the values of \hat{I}_{or}/I_{oc} in table 8.2.2.

Table 8.2.2: Test parameters for Cell selection multi carrier multi cell

Parameter	Unit	Cell 1	Cell 2	Cell 3	Cell 4	Cell 5	Cell 6
UTRA RF Channel Number		Channel 1	Channel 1	Channel 1	Channel 2	Channel 2	Channel 2
CPICH_Ec/Ior	dB	-10	-10	-10	-10	-10	-10
P-CCPCH_Ec/Ior	dB	-12	-12	-12	-12	-12	-12
SCH_Ec/Ior	dB	-12	-12	-12	-12	-12	-12
PICH_Ec/Ior	dB	-15	-15	-15	-15	-15	-15
OCNS_Ec/Ior	dB	-0.941	-0.941	-0.941	-0.941	-0.941	-0.941
\hat{I}_{or}/I_{oc}	dB	5.3	2.3	-1.7	6.3	14.3	2.3
I_{oc}	dBm/ 3.84 MHz	-70			-70		
CPICH_Ec/Io	dB	-13	-16	-20	-19	-11	-23
Propagation Condition		AWGN			AWGN		
Qqualmin	dB	[]	[]	[]	[]	[]	[]
Qrxlevmin	dBm	[]	[]	[]	[]	[]	[]
UE_TXPWR_MAX_RACH	dBm	[]	[]	[]	[]	[]	[]
Qoffsets _{s, n}	dB	C1, C2: [] C1, C3: [] C1, C4: [] C1, C5: [] C1, C6: []	C2, C1: [] C2, C3: [] C2, C4: [] C2, C5: [] C2, C6: []	C3, C1: [] C3, C2: [] C3, C4: [] C3, C5: [] C3, C6: []	C4, C1: [] C4, C2: [] C4, C3: [] C4, C5: [] C4, C6: []	C5, C1: [] C5, C2: [] C5, C3: [] C5, C4: [] C5, C6: []	C6, C1: [] C6, C2: [] C6, C3: [] C6, C4: [] C6, C5: []

8.2.1.1.4.2 Procedures

- The SS activates cell 1-6 and monitors cell 5, 1 and 2 for random access requests from the UE
- The UE is switched on.
- The SS waits for random access request from the UE
- The UE is switched off.
- The SS monitors cell 5, 1 and 2 for random access requests from the UE
- The UE is switched on
- The SS waits for random access request from the UE
- Repeat step d) to g) [TBD] times

8.2.1.1.5 Test requirements

- In step c), the UE shall respond on cell 5 within [FFS seconds]

[Editor's note: LS of proposed timeout values sent to CN1/RAN2 to get acceptance]

- In step g), the UE shall respond on cell 5 within [X] seconds in more than [X%] of the cases.

[Editor's note: The test must be executed a number of times as indirectly set by the Conformance Requirement The number is for FFS]

8.2.1.2 Cell Selection; no cell is present in the neighbour list

8.2.1.2.1 Definition and applicability

Test to verify that the UE is capable of selecting a suitable cell and camp on it within [5] seconds from switch on with stored information of the last registered PLMN. The stored information cell selection delay is then defined as the time the UE needs for sending the preamble for RRC Connection Request for Location Registration to UTRAN after the power has been switched on with a valid USIM and PIN is disabled. The test environment contains only one cell.

This test is applicable for all UEs.

8.2.1.2.2 Conformance requirement

The stored information cell selection delay shall be equal or less than [5] seconds. This shall be verified in more than [X%] of the cases with a confidence level of [Y%] [FFS].

The reference for this requirement is [2] TS 25.133 subclause 4.1.2.1.2 and A.4.1.2.2.

8.2.1.2.3 Test purpose

To verify that the UE meets the conformance requirement.

8.2.1.2.4 Method of test

8.2.1.2.4.1 Initial conditions

This scenario implies the presence of 1 carrier and 1 cell.

The stored information of the last registered PLMN is used in this test. The stored information includes the UTRA RF CHANNEL NUMBER. The active cell in the test does not contain any neighbour cells in its measurement control information.

The absolute signal level of the cell can be obtained from the value of \hat{I}_{or}/I_{oc} in table 8.2.3.

Table 8.2.3: Test parameters for Cell selection single carrier single cell

Parameter	Unit	Cell 1
UTRA RF Channel Number		Channel 1
CPICH_Ec/Ior	dB	-10
P-CCPCH_Ec/Ior	dB	-12
SCH_Ec/Ior	dB	-12
PICH_Ec/Ior	dB	-15
OCNS_Ec/Ior	dB	-0.941
\hat{I}_{or}/I_{oc}	dB	0
I_{oc}	dBm/3.84 MHz	-70
CPICH_Ec/Io	dB	-13
Propagation Condition		AWGN
Qqualmin	dB	[]
Qrxlevmin	dBm	[]
UE_TXPWR_MAX_RACH	dBm	[]

8.2.1.2.4.2 Procedures

- The SS activates cell 1 and monitors cell 1 for random access request from the UE

- b) The UE is switched on
- c) The SS waits for random access request from the UE
- d) The UE is switched off
- e) The SS monitors cell 1 for random access request from the UE
- f) The UE is switched on
- g) The SS waits for random access request from the UE
- h) Repeat step d) to g) [TBD] times

8.2.1.2.5 Test requirements

- 1) In step c), the UE shall respond on cell 1 within [FFS seconds]

[Editor's note: LS of proposed timeout values sent to CN1/RAN2 to get acceptance]

- 2) In step g), the UE shall respond on cell 1 within [5] seconds in more than [X%] of the cases.

[Editor's note: The test must be executed a number of times as indirectly set by the Conformance Requirement. The number is for FFS]

8.2.2 Cell Re-Selection

8.2.2.1 Cell Re-Selection; single carrier case

8.2.2.1.1 Definition and applicability

Test to verify that the UE is capable of re-selecting a new cell within [5] seconds from it becoming a cell to be reselected according to the cell re-selection criteria. The cell re-selection delay is then defined as the time between the occurrence of any event which will trigger Cell Reselection Evaluation process and the moment in time when the UE starts sending the preamble for RRC Connection request for Location Update message to the UTRAN.

This test is applicable for all UEs.

8.2.2.1.2 Conformance requirement

The cell re-selection delay shall be equal or less than [5] seconds. This shall be verified in more than [X%] of the cases with a confidence level of [Y%] [FFS].

The reference for this requirement is [2] TS 25.133 subclause 4.2.2.2.1 and A.4.2.1.2.

8.2.2.1.3 Test purpose

To verify that the UE meets the conformance requirement.

8.2.2.1.4 Method of test

8.2.2.1.4.1 Initial conditions

This scenario implies the presence of 1 carrier and 6 cells as given in Table 8.2.4 and 8.2.5.

Table 8.2.4: General test parameters for Cell Re-selection single carrier multi-cell case

Parameter		Unit	Value	Comment
Initial condition	Active cell		Cell2	
	Neighbour cells		Cell1, Cell3, Cell4, Cell5, Cell6	
Final condition	Active cell		Cell1	
T1		s		T1 need to be defined so that cell re-selection reaction time is taken into account.
T2		s		T2 need to be defined so that cell re-selection reaction time is taken into account.

The relative RF signal to total interference ratio at the UE ($CPICH_{Ec}/I_o$) between the cells is shown in Table 8.2.5 and shall be:

T1: Cell 2 > Cell 1 > Cell 3 = Cell 4 = Cell 5 = Cell 6

T2: Cell 1 > Cell 2 > Cell 3 = Cell 4 = Cell 5 = Cell 6

The absolute signal level of each cell can be obtained from the values of \hat{I}_{or}/I_{oc} in table 8.2.5.

Table 8.2.5: Test parameters for Cell re-selection single carrier multi cell

Parameter	Unit	Cell 1		Cell 2		Cell 3		Cell 4		Cell 5		Cell 6	
		T1	T2	T1	T2	T1	T2	T1	T2	T1	T2	T1	T2
UTRA RF Channel Number		Channel 1		Channel 1		Channel 1		Channel 1		Channel 1		Channel 1	
CPICH_Ec/Ior	dB	-10		-10		-10		-10		-10		-10	
P-CCPCH_Ec/Ior	dB	-12		-12		-12		-12		-12		-12	
SCH_Ec/Ior	dB	-12		-12		-12		-12		-12		-12	
PICH_Ec/Ior	dB	-15		-15		-15		-15		-15		-15	
OCNS_Ec/Ior	dB	-0.941		-0.941		-0.941		-0.941		-0.941		-0.941	
\hat{I}_{or}/I_{oc}	dB	7.3	10.27	10.27	7.3	0.27		0.27		0.27		0.27	
I_{oc}	dBm/ 3.84 MHz	-70											
CPICH_Ec/Io	dB	-16	-13	-13	-16	-23		-23		-23		-23	
Propagation Condition		AWGN											
Cell_selection_and_reselection_quality_measure		CPICH E _c /N ₀		CPICH E _c /N ₀		CPICH E _c /N ₀		CPICH E _c /N ₀		CPICH E _c /N ₀		CPICH E _c /N ₀	
Qqualmin	dB	[]		[]		[]		[]		[]		[]	
Qrxlevmin	dBm	[]		[]		[]		[]		[]		[]	
UE_TXPWR_MAX_RACH	dB	[]		[]		[]		[]		[]		[]	
Qoffset2 _{s, n}	dB	C1, C2: [] C1, C3: [] C1, C4: [] C1, C5: [] C1, C6: []		C2, C1: [] C2, C3: [] C2, C4: [] C2, C5: [] C2, C6: []		C3, C1: [] C3, C2: [] C3, C4: [] C3, C5: [] C3, C6: []		C4, C1: [] C4, C2: [] C4, C3: [] C4, C5: [] C4, C6: []		C5, C1: [] C5, C2: [] C5, C3: [] C5, C4: [] C5, C6: []		C6, C1: [] C6, C2: [] C6, C3: [] C6, C4: [] C6, C5: []	
Qhyst2	dB	[]		[]		[]		[]		[]		[]	
PENALTY_TIME	s	[]		[]		[]		[]		[]		[]	
TEMP_OFFSET2	dB	[]		[]		[]		[]		[]		[]	
Treselection	s	[]		[]		[]		[]		[]		[]	
Sintrasearch	dB	[]		[]		[]		[]		[]		[]	

8.2.2.1.4.2 Procedures

- a) The SS activates cell 1-6 with T1 defined parameters and monitors cell 1 and 2 for random access requests from the UE
- b) The UE is switched on
- c) The SS waits for random access requests from the UE
- d) After [T1] seconds from switch on, the parameters are changed as described for T2
- e) The SS waits for random access requests from the UE
- f) After [T2] seconds from switch on, the parameters are changed as described for T1
- g) Repeat step c) to f) [TBD] times

8.2.2.1.5 Test requirements

1) In step c), the UE shall respond on cell 2 within [FFS seconds]

[Editor's note: LS of proposed timeout values sent to CN1/RAN2 to get acceptance]

2) In step e), the UE shall respond on cell 1 within [5] seconds in more than [X%] of the cases.

[Editor's note: The test must be executed a number of times as indirectly set by the Conformance Requirement The number is for FFS]

8.2.2.2 Cell Re-Selection; multi carrier case

8.2.2.2.1 Definition and applicability

Test to verify that the UE is capable of re-selecting a new cell within [Nt] seconds from it becoming a cell to be reselected according to the cell re-selection criteria. The cell re-selection delay is then defined as the time between the occurrence of any event which will trigger Cell Reselection Evaluation process and the moment in time when the UE starts sending the preamble for RRC Connection request for Location Update message to the UTRAN.

This test is applicable for all UEs.

8.2.2.2.2 Conformance requirement

The cell re-selection delay shall be equal or less than [Nt] seconds. This shall be verified in more than [90%] of the cases with a confidence level of [Y%] [FFS]

The reference for this requirement is [2] TS 25.133 subclause 4.2.2.2.2 and A.4.2.2.2.

8.2.2.2.3 Test purpose

To verify that the UE meets the conformance requirement.

8.2.2.2.4 Method of test

8.2.2.2.4.1 Initial conditions

This scenario implies the presence of 2 carriers and 6 cells as given in Table 8.2.6 and 8.2.7.

Table 8.2.6: General test parameters for Cell Re-selection in Multi carrier case

Parameter		Unit	Value	Comment
Initial condition	Active cell		Cell2	
	Neighbour cells		Cell1, Cell3, Cell4, Cell5, Cell6	
Final condition	Active cell		Cell1	
T1		s		T1 need to be defined so that cell re-selection reaction time is taken into account.
T2		s		T2 need to be defined so that cell re-selection reaction time is taken into account.

The relative RF signal to total interference ratio at the UE ($CPICH_{Ec}/I_o$) between the cells is shown in Table 8.2.7 and shall be:

T1: Cell 2 > Cell 1 > Cell 3 = Cell 4 = Cell 5 = Cell 6

T2: Cell 1 > Cell 2 > Cell 3 = Cell 4 = Cell 5 = Cell 6

The absolute signal level of each cell can be obtained from the values of \hat{I}_{or}/I_{oc} in table 8.2.7.

Table 8.2.7: Test parameters for Cell re-selection multi carrier multi cell

Parameter	Unit	Cell 1		Cell 2		Cell 3		Cell 4		Cell 5		Cell 6	
		T1	T2	T1	T2	T1	T2	T1	T2	T1	T2	T1	T2
UTRA RF Channel Number		Channel 1		Channel 2		Channel 1		Channel 1		Channel 2		Channel 2	
CPICH_Ec/Ior	dB	-10		-10		-10		-10		-10		-10	
P-CCPCH_Ec/Ior	dB	-12		-12		-12		-12		-12		-12	
SCH_Ec/Ior	dB	-12		-12		-12		-12		-12		-12	
PICH_Ec/Ior	dB	-15		-15		-15		-15		-15		-15	
OCNS_Ec/Ior	dB	-0.941		-0.941		-0.941		-0.941		-0.941		-0.941	
\hat{I}_{or}/I_{oc}	dB	-3.4	2.2	2.2	-3.4	-7.4	-4.8	-7.4	-4.8	-4.8	-7.4	-4.8	-7.4
I_{oc}	dBm/ 3.84 MHz	-70											
CPICH_Ec/Io	dB	-16	-13	-13	-16	-20		-20		-20		-20	
Propagation Condition		AWGN											
Cell_selection_and_reselection_quality_measure		CPICH E _c /N ₀		CPICH E _c /N ₀		CPICH E _c /N ₀		CPICH E _c /N ₀		CPICH E _c /N ₀		CPICH E _c /N ₀	
Qqualmin	dB	[]		[]		[]		[]		[]		[]	
Qrxlevmin	dBm	[]		[]		[]		[]		[]		[]	
UE_TXPWR_MAX_RACH	dB	[]		[]		[]		[]		[]		[]	
Qoffset _{s, n}	dB	C1, C2: [] C1, C3: [] C1, C4: [] C1, C5: [] C1, C6: []		C2, C1: [] C2, C3: [] C2, C4: [] C2, C5: [] C2, C6: []		C3, C1: [] C3, C2: [] C3, C4: [] C3, C5: [] C3, C6: []		C4, C1: [] C4, C2: [] C4, C3: [] C4, C5: [] C4, C6: []		C5, C1: [] C5, C2: [] C5, C3: [] C5, C4: [] C5, C6: []		C6, C1: [] C6, C2: [] C6, C3: [] C6, C4: [] C6, C5: []	
Qhyst	dB	[2]		[2]		[2]		[2]		[2]		[2]	
PENALTY_TIME	s	[]		[]		[]		[]		[]		[]	
TEMP_OFFSET	dB	[]		[]		[]		[]		[]		[]	
Treselection	s	[5]		[5]		[5]		[5]		[5]		[5]	
Sintrasearch	dB	[]		[]		[]		[]		[]		[]	
Sintersearch	dB	[-8]		[-8]		[-8]		[-8]		[-8]		[-8]	

8.2.2.4.2 Procedures

- The SS activates cell 1-6 with T1 defined parameters and monitors cell 1 and 2 for random access requests from the UE
- The UE is switched on
- The SS waits for random access requests from the UE
- After [T1] seconds from switch on, the parameters are changed as described for T2
- The SS waits for random access request from the UE
- After [T2] seconds from switch on, the parameters are changed as described for T1
- Repeat step c) to f) [TBD] times

8.2.2.5 Test requirements

- In step c), the UE shall respond on cell 2 within [FFS seconds]

[Editor's note: LS of proposed timeout values sent to CN1/RAN2 to get acceptance]

- In step e), the UE shall respond on cell 1 within [Nt] seconds in more than [90%] of the cases.

[Editor's note: The test must be executed a number of times as indirectly set by the Conformance Requirement The number is for FFS]

8.2.3 UTRAN to GSM Cell Re-Selection

8.2.3.1 Definition and applicability

Test to verify that a UE camped on a UTRAN cell is capable of re-selecting a GSM cell within [X] seconds from it becoming a cell to be reselected according to the cell re-selection criteria. The cell re-selection delay is then defined as the time between the occurrence of any event which will trigger Cell Reselection Evaluation process and the moment in time when the UE starts sending the RR Channel Request message for location update to GSM.

This test is applicable for UEs supporting both UTRAN and GSM.

8.2.3.2 Conformance requirement

The UTRAN to GSM cell re-selection delay shall be equal or less than [x] seconds. This shall be verified in more than [90%] of the cases with a confidence level of [Y%] [FFS]

The reference for this requirement is [2] TS 25.133 subclause 4.3.2.1 and A.4.3.1.2.

8.2.3.3 Test purpose

To verify that the UE meets the conformance requirement.

8.2.3.4 Method of test

8.2.3.4.1 Initial conditions

This scenario implies the presence of 1 UTRAN serving cell, and 1 GSM cell to be re-selected.

Table 8.2.8: General test parameters for UTRAN to GSM Cell Re-selection

Parameter		Unit	Value	Comment
Initial condition	Active cell		Cell1	
	Neighbour cell		Cell2	
Final condition	Active cell		Cell2	
T1		s		T1 need to be defined so that cell re-selection reaction time is taken into account.
T2		s		T2 need to be defined so that cell re-selection reaction time is taken into account.

Table 8.2.9: Cell re-selection UTRAN to GSM cell case (cell 1)

Parameter	Unit	Cell 1 (UTRA)	
		T1	T2
UTRA RF Channel Number		Channel 1	
CPICH_Ec/Ior	dB	-10	
P-CCPCH_Ec/Ior	dB	-12	
SCH_Ec/Ior	dB	-12	
PICH_Ec/Ior	dB	-15	
OCNS_Ec/Ior	dB	-0.941	
\hat{I}_{or}/I_{oc}	dB	10.3	7.3
I_{oc}	dBm/3.84 MHz	-70	
CPICH_Ec/Io	dB	-13	-16
CPICH_RSCP	dBm	[L1]	[L2]
Propagation Condition		AWGN	
Cell_selection_and_reselection_quality_measure		CPICH E _c /N ₀	
Qqualmin	dB	[]	
Qrxlevmin	dBm	[]	
UE_TXPWR_MAX_RACH	dBm	[]	
Qoffset1 _{s, n}	dB	C1, C2: []	
Qhyst1	dB	[]	
PENALTY_TIME	s	C2: []	
TEMP_OFFSET1	dB	C2: []	
Treselection	s	[]	
SsearchRAT	dB	[]	

Table 8.2.10: Cell re-selection UTRAN to GSM cell case (cell 2)

Parameter	Unit	Cell 2 (GSM)	
		T1	T2
Absolute RF Channel Number		ARFCN 1	
RXLEV	dBm	-70	-60
RXLEV_ACCESS_MIN	dBm	[]	
MS_TXPWR_MAX_CCH	dBm	[]	

8.2.3.4.2 Procedures

- The SS activates cell 1 and 2 with T1 defined parameters and monitors cell 1 and 2 for random access requests from the UE
- The UE is switched on
- The SS waits for random access request from the UE
- After [T1] seconds from switch on, the parameters are changed as described for T2
- The SS waits for random access request from the UE
- After [T2] seconds from switch on, the parameters are changed as described for T1
- Repeat step c) to f) [TBD] times

8.2.3.5 Test requirements

1) In step c), the UE shall respond on cell 1 within [TBD] seconds

[Editor's note: LS of proposed timeout values sent to CN1/RAN2 to get acceptance]

2) In step e), the UE shall respond on cell 2 within [X] seconds in more than [90%] of the cases.

[Editor's note: The test must be executed a number of times as indirectly set by the Conformance Requirement. The number is for FFS]

8.3 UTRAN Connected mode mobility

8.3.1 FDD/FDD Soft Handover

8.3.1.1 Active set dimension

8.3.1.2 Active set update delay

8.3.2 FDD/FDD Hard Handover

8.3.2.1 Hard handover delay

8.3.2.2 Interruption time

8.3.3 FDD/TDD Handover

8.3.3.1 Hard handover delay

8.3.3.2 Interruption time

8.3.4 FDD/GSM Handover

8.3.4.1 Inter-system handover delay

8.3.4.2 Interruption time

8.3.5 Cell Re-selection in CELL_FACH

8.3.5.1 All cells in the neighbour list belong to the same frequency

8.3.5.2 The cells in the neighbour list belong to different frequencies

8.3.6 Cell Re-selection in CELL_PCH

8.3.6.1 All cells in the neighbour list belong to the same frequency

8.3.6.2 The cells in the neighbour list belong to different frequencies

8.3.7 Cell Re-selection in URA_PCH

8.3.7.1 All cells in the neighbour list belong to the same frequency

8.3.7.2 The cells in the neighbour list belong to different frequencies

8.4 RRC Connection Control

8.4.1 RRC Re-establishment

8.4.1.1 Target cell known by UE

8.4.1.2 Target cell not known by UE

8.4.2 Spare

8.4.3 Random Access

8.4.3.1 Correct behaviour when receiving an ACK

8.4.3.2 Correct behaviour when receiving an NACK

8.4.3.3 Correct behaviour at Time-out

8.4.3.4 Correct behaviour when reaching maximum transmit power

8.4.4 Transport format combination selection in UE

8.5 Timing and Signalling characteristics

8.5.1 UE Transmit Timing

8.5.1.1 Initial transmission timing, Maximum timing adjustment size and Maximum timing adjustment rate

8.5.1.1.1 Definition and applicability

The UE shall have capability to follow the frame timing change of the connected Node B. UE initial transmit timing accuracy, maximum amount of timing change in one adjustment, and maximum adjustment rate are defined in the following requirements.

<Editor's Note: The applicability for this test whether it is mandatory or not should be clarified.>

8.5.1.1.2 Conformance requirements

For parameters specified in Table 8.5.1.1.1, UE initial transmission timing error shall be less than or equal to $\pm 1,5$ Chip. The reference point for the UE initial transmit timing control requirement shall be the first significant path of the corresponding downlink DPCCCH/DPDCH frame.

The UE shall be capable of changing the transmission timing according the received downlink DPCCCH/DPDCH frame. The maximum amount of the timing change in one adjustment shall be 1/4 Chip.

The maximum adjustment rate shall be 1/4 chip per 280 ms. In particular, within any given 280 ms period, the UE transmit timing shall not change in excess of $\pm 1/4$ chip from the timing at the beginning of this 280 ms period.

Table 8.5.1.1.1: Test parameters for Transmission timing requirement

Parameter	Cell 1 and 2 level	Unit
DPCH_Ec/ Ior	-17	dB
I _{or} , Cell 1	-96	dBm / 3.84 MHz
I _{or} , Cell 2	-97	dBm / 3.84 MHz
Information data rate	12.2	kbps
TFCI	On	-
Propagation condition	AWGN	

- Cell 2 starts transmission 5 seconds after call has been initiated. UE shall maintain it's original timing properties.
- Cell 1 stop transmission 5 seconds after cell 2 has started transmission. UE shall adjust transmission timing with a maximum change of 1/4 chip per adjustment, and maximum timing adjustment rate of 1/4 chip per 280 ms.

The reference for this requirement is [2] TS 25.133 subclause 7.1.2 and A.7.1.2.

8.5.1.1.3 Test purpose

[TBD]

8.5.1.1.4 Method of test

8.5.1.1.4.1 Initial conditions

[TBD]

8.5.1.1.4.2 Procedures

[TBD]

8.5.1.1.5 Test requirements

[TBD]

8.5.2 Signalling Response Delay

8.5.3 Signalling Processing

8.6 UE Measurements Procedures

8.6.1 Measurements in CELL_DCH State

8.6.1.1 FDD intra frequency measurements

8.6.1.1.1 Identification of a new cell

8.6.1.1.2 UE CPICH measurement capability

8.6.1.1.3 Periodic Reporting

8.6.1.1.4 Event Triggered Periodic Reporting

8.6.1.1.5 Event Triggered Reporting

8.6.1.2 FDD inter frequency measurements

8.6.1.2.1 Identification of a new cell

8.6.1.2.2 Measurement period

8.6.1.2.3 Periodic Reporting

8.6.1.2.4 Event Triggered Reporting

8.6.1.3 TDD measurements

8.6.1.3.1 Periodic Reporting

8.6.1.3.2 Event Triggered Reporting

8.6.1.4 GSM measurements

8.6.1.4.1 GSM carrier RSSI

8.6.1.4.2 BSIC verification

8.6.1.4.2.1 Initial BSIC verification

8.6.1.4.2.2 BSIC re-confirmation

8.6.2 Parallel Measurements in CELL_DCH State

8.6.3 Measurements in CELL_FACH State

8.7 Measurements Performance Requirements

8.7.1 CPICH RSCP

8.7.1.1 Intra frequency measurements accuracy

8.7.1.1.1 Absolute accuracy requirement

- 8.7.1.1.2 Relative accuracy requirement

- 8.7.1.2 Inter frequency measurement accuracy
 - 8.7.1.2.1 Relative accuracy requirement

- 8.7.1.3 CPICH RSCP measurement report mapping

- 8.7.2 CPICH E_c/I_0
 - 8.7.2.1 Intra frequency measurements accuracy
 - 8.7.2.1.1 Absolute accuracy requirement
 - 8.7.2.1.2 Relative accuracy requirement
 - 8.7.2.2 Inter frequency measurement accuracy
 - 8.7.2.2.1 Relative accuracy requirement
 - 8.7.2.3 CPICH E_c/I_0 measurement report mapping

- 8.7.3 UTRA Carrier RSSI
 - 8.7.3.1 Absolute accuracy requirement
 - 8.7.3.2 Relative accuracy requirement
 - 8.7.3.3 UTRA Carrier RSSI measurement report mapping

- 8.7.4 GSM carrier RSSI

8.7.5 Transport channel BLER

8.7.5.1 BLER measurement requirement

8.7.5.2 Transport channel BLER measurement report mapping

8.7.6 UE transmitted power

8.7.6.1 Accuracy requirement

8.7.6.2 UE transmitted power measurement report mapping

8.7.7 SFN-CFN observed time difference

8.7.7.1 Intra frequency measurement requirement

8.7.7.2 Inter frequency measurement requirement

8.7.7.3 SFN-CFN observed time difference measurement report mapping

8.7.8 SFN-SFN observed time difference

8.7.8.1 SFN-SFN observed time difference type 1

8.7.8.1.1 Measurement requirement

8.7.8.1.2 SFN-SFN observed time difference type 1 measurement report mapping

8.7.8.2 SFN-SFN observed time difference type 2

8.7.8.2.1 Intra frequency measurement requirement accuracy without IPDL period active

8.7.8.2.2 Intra frequency measurement requirement accuracy with IPDL period active

- 8.7.8.2.3 Inter frequency measurement requirement accuracy
- 8.7.8.2.4 SFN-SFN observed time difference type 2 measurement report mapping
- 8.7.9 UE Rx-Tx time difference
 - 8.7.9.1 Measurement requirement
 - 8.7.9.2 UE Rx-Tx time difference measurement report mapping
- 8.7.10 Observed time difference to GSM cell
 - 8.7.10.1 Measurement requirement
 - 8.7.10.2 Observed time difference to GSM cell measurement report mapping
- 8.7.11 P-CCPCH RSCP
 - 8.7.11.1 Absolute accuracy requirements
 - 8.7.11.2 P-CCPCH RSCP measurement report mapping
- 8.7.12 UE GPS Timing of Cell Frames for LCS
 - 8.7.12.1 UE GPS timing of Cell Frames for LCS measurement report mapping

Annex A (informative): Connection Diagrams

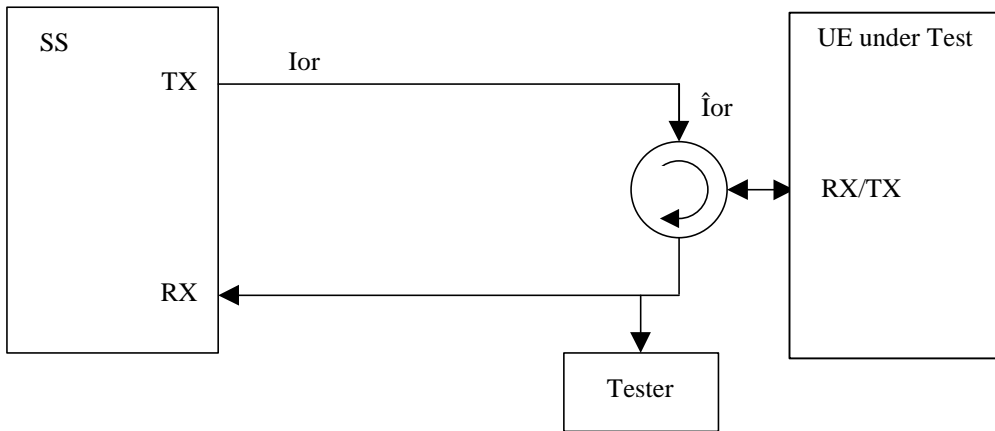

Figure A.1: Connection for Basic TX Test

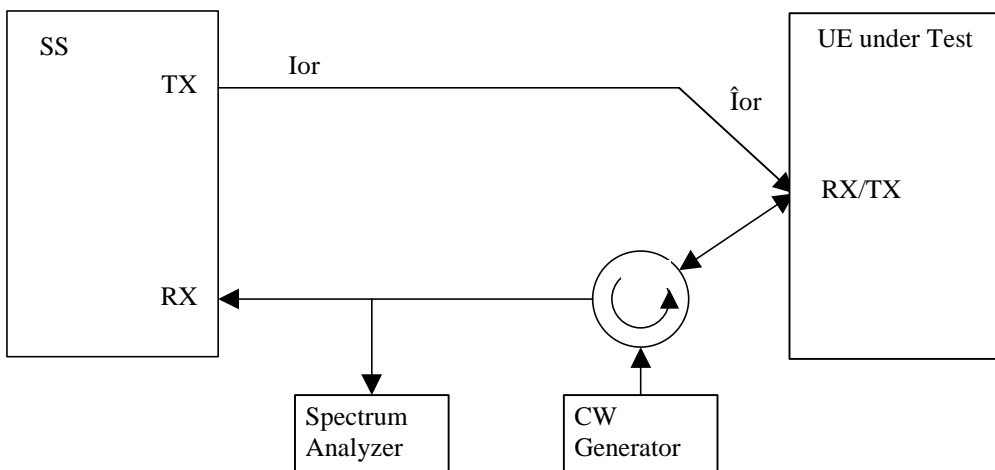

Figure A.2: Connection for TX Intermodulation Test

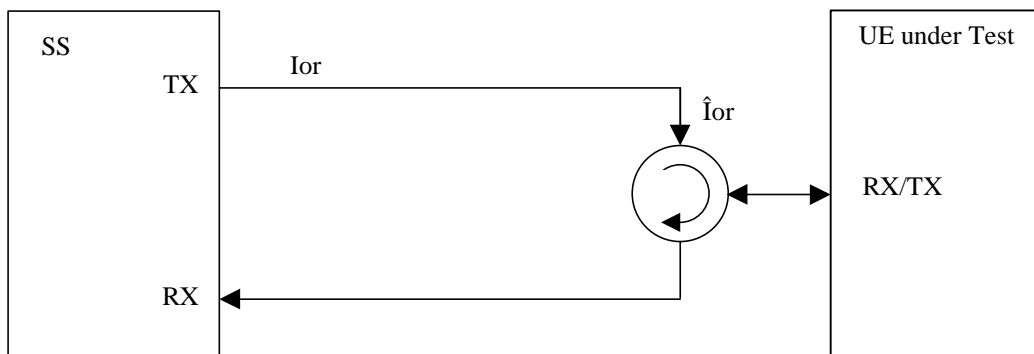

Figure A.3: Connection for Basic RX Test

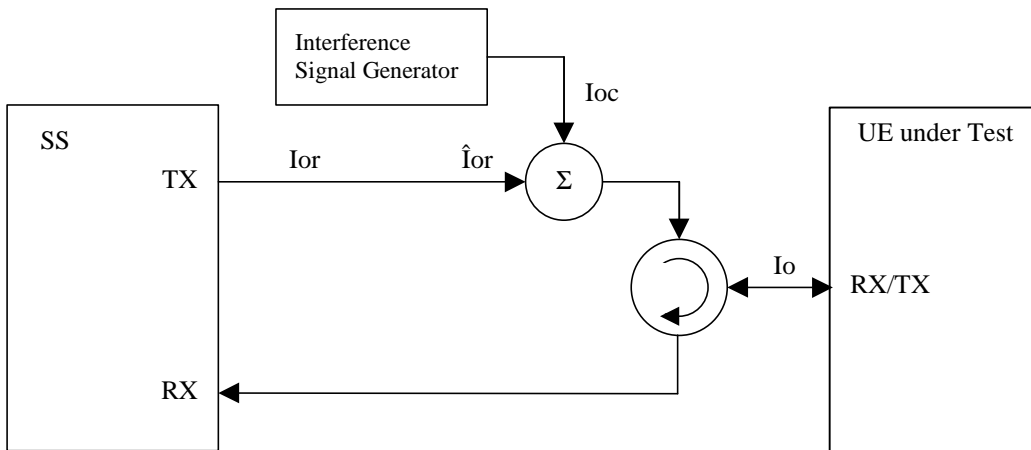

Figure A.4: Connection for RX Test with Interference

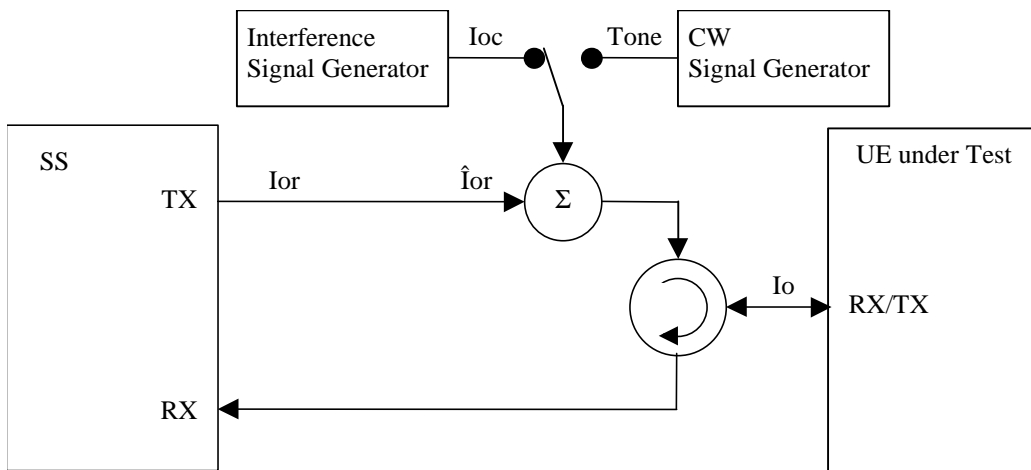

Figure A.5: Connection for RX Test with Interference or additional CW

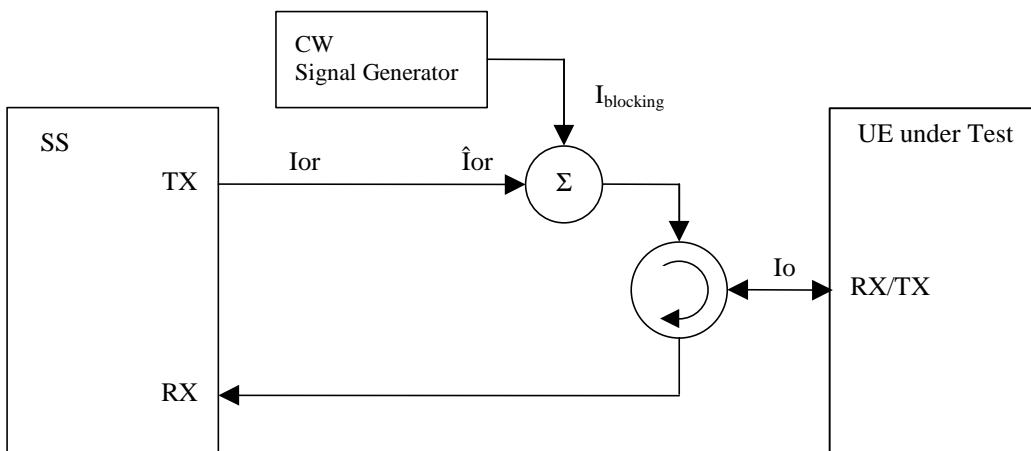

Figure A.6: Connection for RX Test with additional CW

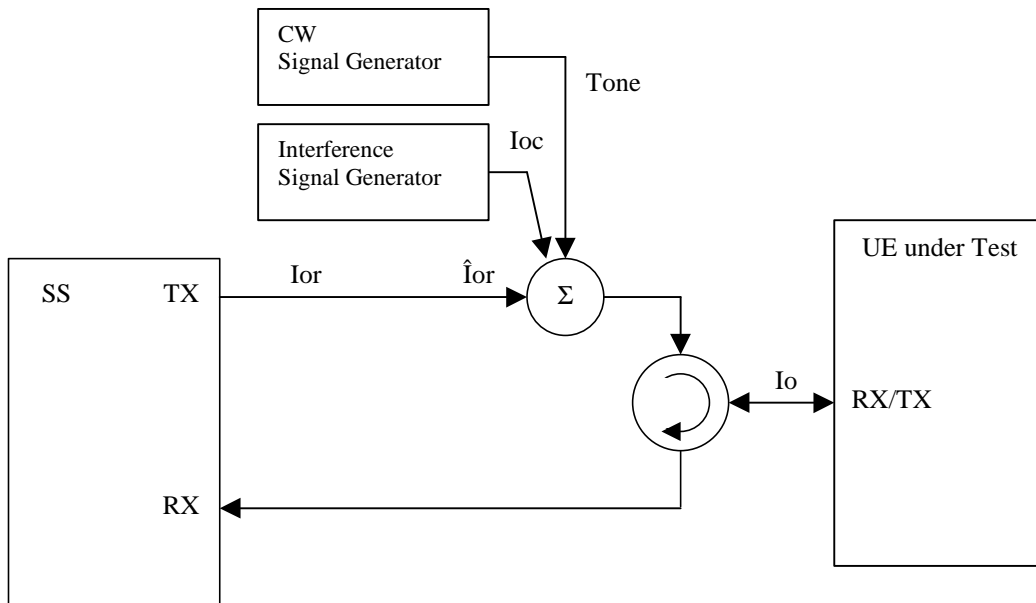

Figure A.7: Connection for RX Test with both Interference and additional CW

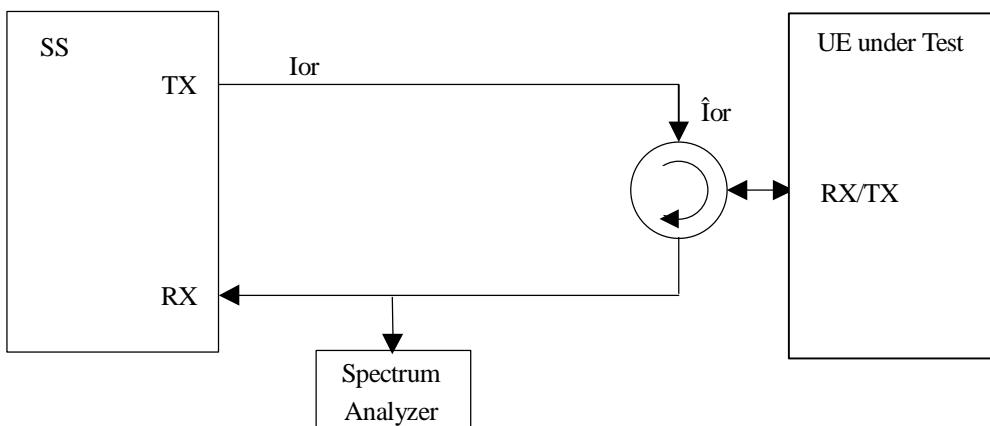

Figure A.8: Connection for Spurious Emission Test

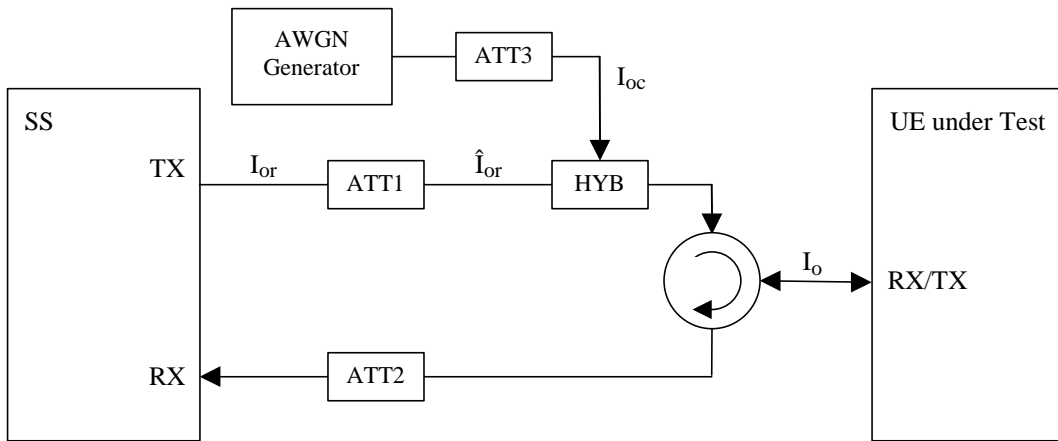

Figure A.9: Connection for Static Propagation Test

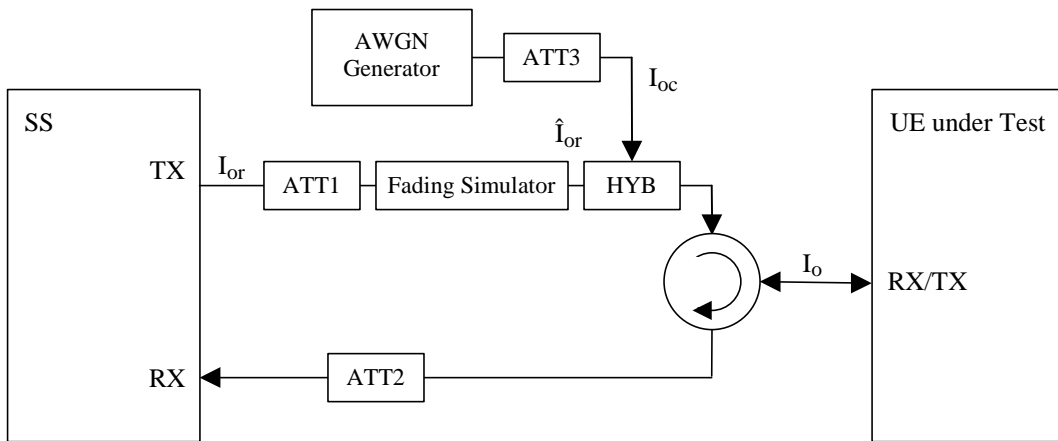

Figure A.10: Connection for Multi-path Fading Propagation Test

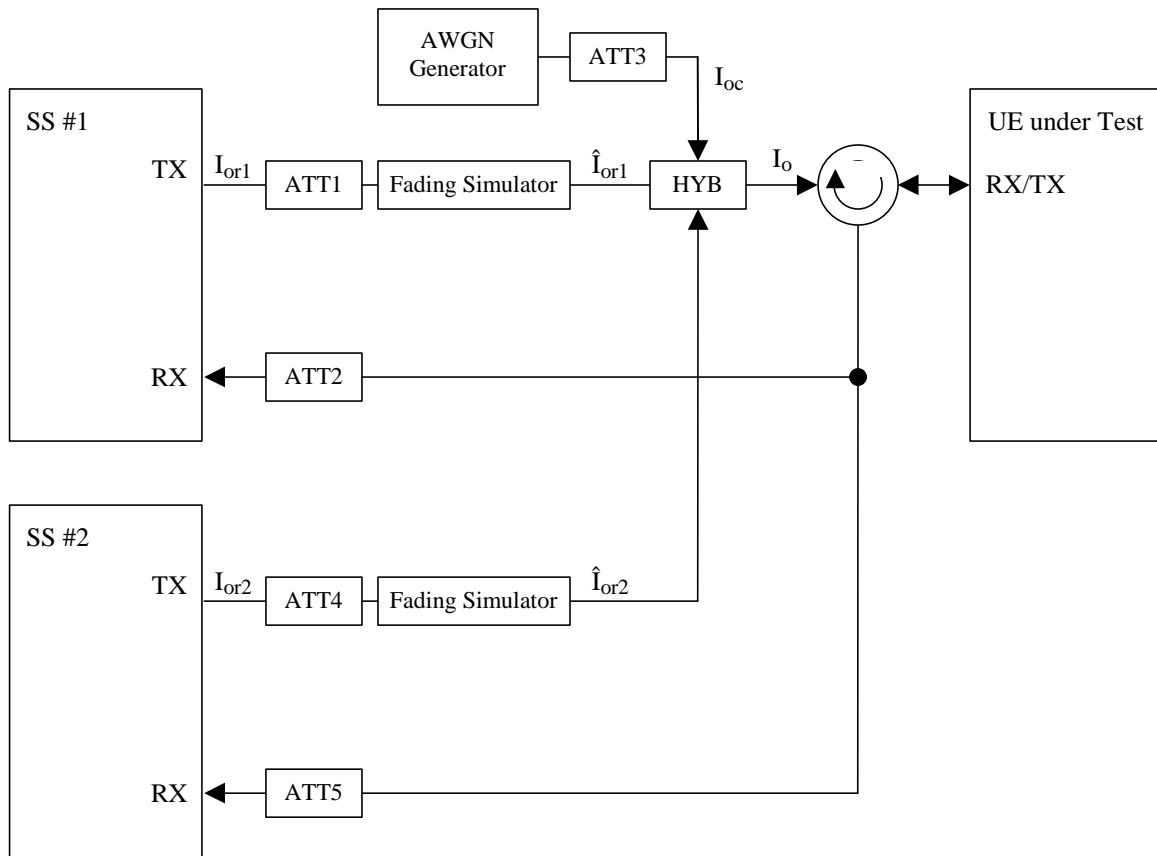

Figure A.11: Connection for Inter-Cell Soft Handover Test

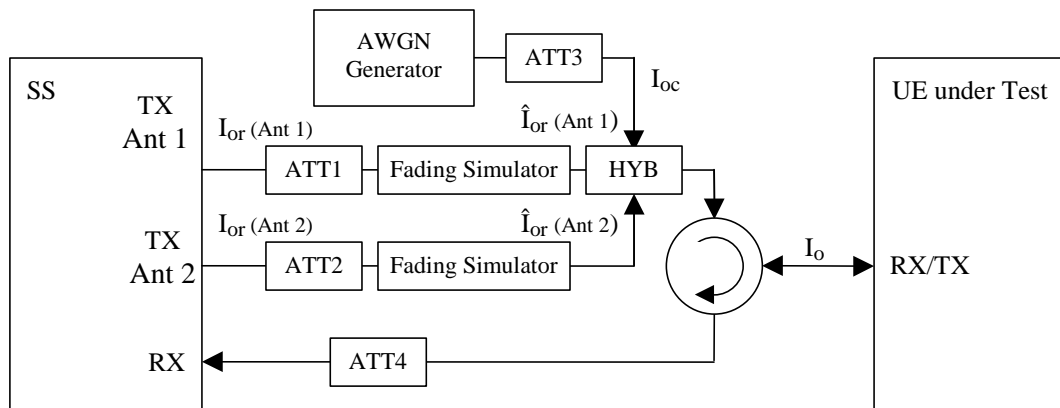

Figure A.12: Connection for Demodulation of DCH in open and closed loop transmit diversity modes

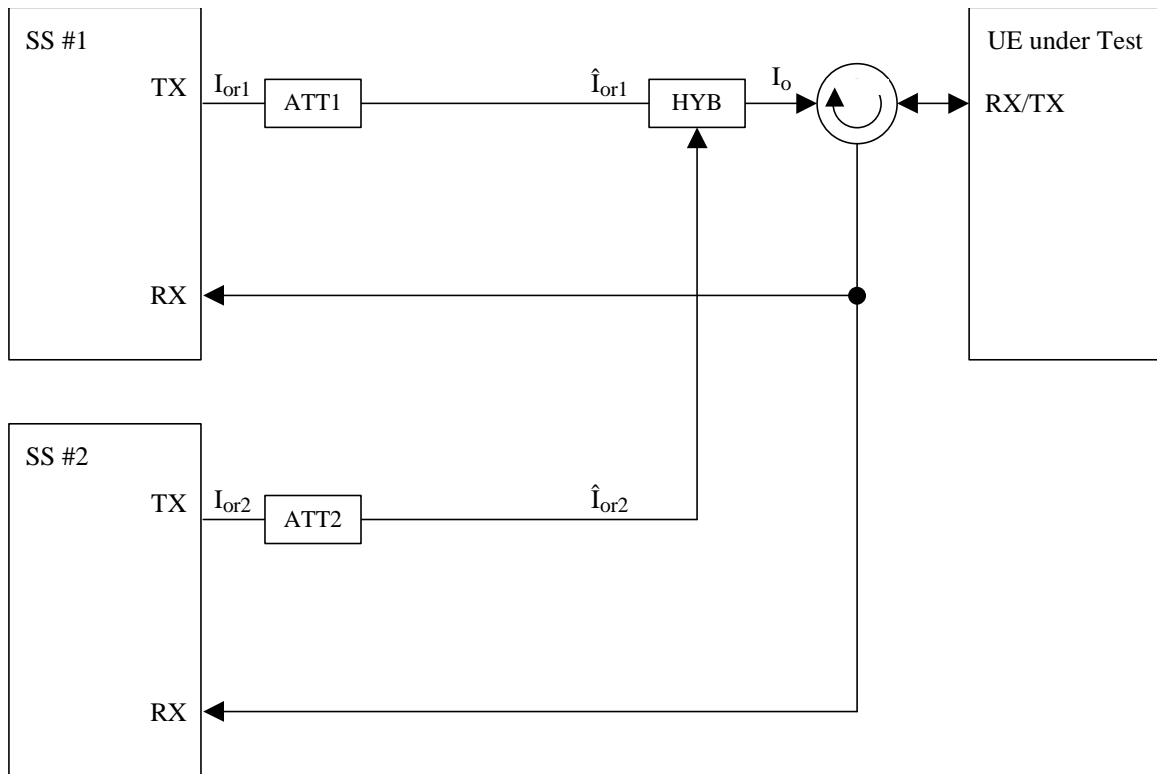

Figure A.13: Connection for Combining of TPC commands in Soft Handover Test 1

Annex B (normative): Global In-Channel TX-Test

B.1 General

The global in-channel Tx test enables the measurement of all relevant parameters that describe the in-channel quality of the output signal of the Tx under test in a single measurement process.

The objective of this Annex is to list the results that shall be available from the Global In-Channel TX-Test. To aid understanding, an example algorithmic description of the measurement process is provided. It is not intended that this particular method is required. It is however required that any algorithm that is used for In-Channel TX tests should deliver the required results with the required accuracy.

All notes referred in the various subclauses of B.2 are put together in B.3.

B.2 Definition of the process

B.2.1 Basic principle

The process is based on the comparison of the actual **output signal of the TX under test**, received by an ideal receiver, with a **reference signal**, that is generated by the measuring equipment and represents an ideal error free received signal. All signals are represented as equivalent (generally complex) baseband signals.

B.2.2 Output signal of the TX under test

The output signal of the TX under test is acquired by the measuring equipment, filtered by a matched filter (RRC 0.22, correct in shape and in position on the frequency axis) and stored at one sample per chip at the Inter-Symbol-Interference free instants.

The following form represents the physical signal in the entire measurement interval:

one vector **Z**, containing $N = n_s \times sf + m_a$ complex samples;

with

n_s : number of symbols in the measurement interval;

sf : number of chips per symbol. (sf : spreading factor) (see Note: Symbol length)

m_a : number of midamble chips (only in TDD)

B.2.3 Reference signal

The reference signal is constructed by the measuring equipment according to the relevant TX specifications.

It is filtered by the same matched filter, mentioned in B.2.2., and stored at the Inter-Symbol-Interference free instants. The following form represents the reference signal in the entire measurement interval:

one vector **R**, containing $N = n_s \times sf + m_a$ complex samples;

n_s , sf , m_a : see B.2.2

B.2.4 void

B.2.5 Classification of measurement results

The measurement results achieved by the global in-channel TX test can be classified into two types:

- Results of type “deviation”, where the error-free parameter has a non-zero magnitude. (These are the parameters that quantify the integral physical characteristic of the signal). These parameters are:

RF Frequency

Power (in case of single code)

Code Domain Power (in case of multi code)

Timing (only for UE)

(Additional parameters: see Note: Deviation)

- Results of type “residual”, where the error-free parameter has value zero. (These are the parameters that quantify the error values of the measured signal, whose ideal magnitude is zero). These parameters are:

Error Vector Magnitude (EVM);

Peak Code Domain Error (PCDE).

(Additional parameters: see Note residual)

B.2.6 Process definition to achieve results of type “deviation”

The reference signal (**R**; see subclause B.2.3) is varied with respect to the parameters mentioned in subclause B.2.5 under "results of type deviation" in order to achieve best fit with the recorded signal under test (**Z**; see subclause B.2.2). Best fit is achieved when the RMS difference value between the signal under test and the varied reference signal is an absolute minimum. The varied reference signal, after the best fit process, will be called **R'**.

The varying parameters, leading to **R'** represent directly the wanted results of type “deviation”. These measurement parameters are expressed as deviation from the reference value with units same as the reference value.

In case of multi code, the type-“deviation”-parameters (frequency, timing and (RF-phase)) are varied commonly for all codes such that the process returns one frequency-deviation, one timing deviation, (one RF-phase –deviation).

(These parameters are not varied on the individual codes signals such that the process returns k frequency errors... . (k: number of codes)).

The only type-“deviation”-parameters varied individually are code powers such that the process returns k code power deviations (k: number of codes).

B.2.7 Process definition to achieve results of type “residual”

The difference between the varied reference signal (**R'**; see subclause B.2.6.) and the TX signal under test (**Z**; see subclause B.2.2) is the error vector **E** versus time:

$$\mathbf{E} = \mathbf{Z} - \mathbf{R}'.$$

Depending on the parameter to be evaluated, it is appropriate to represent **E** in one of the following two different forms:

Form EVM (representing the physical error signal in the entire measurement interval)

One vector **E**, containing $N = n_s \times s_f + m_a$ complex samples;

n_s , s_f , m_a : see B.2.2

Form PCDE (derived from Form EVM by separating the samples into symbol intervals)

ns time-sequential vectors **e** with sf complex samples comprising one symbol interval.

E gives results of type "residual" applying the two algorithms defined in subclauses B 2.7.1 and B 2.7.2.

B.2.7.1 Error Vector Magnitude (EVM)

The Error Vector Magnitude EVM is calculated according to the following steps:

- 1) Take the error vector **E** defined in subclause B.2.7 (Form EVM) and calculate the RMS value of **E**; the result will be called RMS(**E**).
- 2) Take the varied reference vector **R'** defined in subclause B.2.6 and calculate the RMS value of **R'**; the result will be called RMS(**R'**).
- 3) Calculate EVM according to:

$$\text{EVM} = \frac{\text{RMS}(\mathbf{E})}{\text{RMS}(\mathbf{R}')} \times 100\% \quad (\text{here, EVM is relative and expressed in \%})$$

(see note TDD)

B.2.7.2 Peak Code Domain Error (PCDE)

The Peak Code Domain Error is calculated according to the following steps:

- 1) Take the error vectors **e** defined in subclause B.2.7 (Form PCDE)
- 2) Take the orthogonal vectors of the channelisation code set **C** (all codes belonging to one spreading factor) as defined in TS 25.213 and TS 25.223 (range +1, -1). (see Note: Symbol length)
- 3) To achieve meaningful results it is necessary to descramble **e**, leading to **e'** (see Note1: Scrambling code)
- 4) Calculate the inner product of **e'** with **C**. Do this for all symbols of the measurement interval and for all codes in the code space.
This gives an array of format k x ns, each value representing an error-vector representing a specific symbol and a specific code, which can be exploited in a variety of ways.
k: number of codes
ns: number of symbols in the measurement interval
- 5) Calculate k RMS values, each RMS value unifying ns symbols within one code.
(These values can be called "*Absolute CodeEVMs*" [Volt].)
- 6) Find the peak value among the k "*Absolute CodeEVMs*".
(This value can be called "*Absolute PeakCodeEVM*" [Volt].)

7) Calculate PCDE according to:

$$10 \cdot \lg \frac{(\text{“Absolute PeakCodeEVM”})^2}{(\text{RMS}(\mathbf{R}'))^2} \quad \text{dB} \quad (\text{a relative value in dB}).$$

(see Note: Denominator)

(see Note2: Scrambling code)

(see Note IQ)

(see Note TDD)

(see Note Synch channel)

B.3 Notes

Note: Symbol length)

A general code multiplexed signal is multicode and multirate. In order to avoid unnecessary complexity, the measurement applications use a unique symbol-length, corresponding to a spreading factor, regardless of the really intended spreading factor. Nevertheless the complexity with a multicode / multirate signal can be mastered by introducing appropriate definitions.

Note: Deviation)

It is conceivable to regard more parameters as type „deviation“ e.g. Chip frequency and RF-phase.

As chip-frequency and RF-frequency are linked together by a statement in the core specifications [1] it is sufficient to process RF frequency only.

A parameter RF-phase must be varied within the best fit process (B 2.6.). Although necessary, this parameter-variation doesn't describe any error, as the modulation schemes used in the system don't depend on an absolute RF-phase.

Note: residual)

It is conceivable to regard more parameters as type „residual“ e.g. IQ origin offset. As it is not the intention of the test to separate for different error sources, but to quantify the quality of the signal, all such parameters are not extracted by the best fit process, instead remain part of EVM and PCDE.

Note: Denominator)

If the denominator stems from mutual time shifted signals of different code powers, (e.g. Node B, FDD) the measurement result PCDE should be expressed absolutely instead.

Note1: Scrambling Code)

In general a TX signal under test can use more than one scrambling code. Note that PCDE is processed regarding the unused channelisation - codes as well. In order to know which scrambling code shall be applied on unused channelisation -codes, it is necessary to restrict the test conditions: TX signal under test shall use exactly one scrambling code.

Note2 Scrambling Code)

To interpret the measurement results in practice it should be kept in mind that erroneous code power on unused codes is generally de-scrambled differently under test conditions and under real life conditions, whereas erroneous code power on used codes is generally de-scrambled equally under test conditions and under real life conditions. It might be indicated if a used or unused code hits PCDE.

Note IQ)

As in FDD/uplink each code can be used twice, on the I and on the Q channel, the measurement result may indicate on which channel (I or Q) PCDE occurs.

Note TDD)

EVM covers the midamble part as well as the data part; however PCDE disregards the midamble part.

Note: Synch Channel)

A Node B signal contains a physical synch channel, which is non orthogonal, related to the other DPCHs. In this context note: The code channel bearing the result of PCDE is exactly one of the DPCHs (never the synch channel). The origin of PCDE (erroneous code power) can be any DPCH and/or the synch channel.

Annex C (normative): Measurement channels

C.1 General

The measurement channels in this annex are defined to derive the requirements in clauses 5, 6 and 7. The measurement channels represent example configuration of radio access bearers for different data rates.

The measurement channel for 12.2 kbps shall be supported by any UE both in up- and downlink. Support for other measurement channels is depending on the UE Radio Access capabilities.

C.2 UL reference measurement channel

C.2.1 UL reference measurement channel (12.2 kbps)

The parameters for the 12.2 kbps UL reference measurement channel are specified in Table C.2.1.1 and Table C.2.1.2. The channel coding for information is shown in Figure C.2.1

Table C.2.1.1: UL reference measurement channel physical parameters (12.2 kbps)

Parameter	Level	Unit
Information bit rate	12.2	kbps
DPDCH	60	kbps
DPCCH	15	kbps
DPCCH Slot Format #i	0	-
DPCCH/DPDCH power ratio	-5.46	dB
TFCI	On	-
Repetition	23	%
NOTE: Slot Format #2 is used for closed loop tests in subclause 7.6.2.		

Table C.2.1.2: UL reference measurement channel, transport channel parameters (12.2 kbps)

Parameters	DTCH	DCCH
Transport Channel Number	1	2
Transport Block Size	244	100
Transport Block Set Size	244	100
Transmission Time Interval	20 ms	40 ms
Type of Error Protection	Convolution Coding	Convolution Coding
Coding Rate	1/3	1/3
Rate Matching attribute	256	256
Size of CRC	16	12

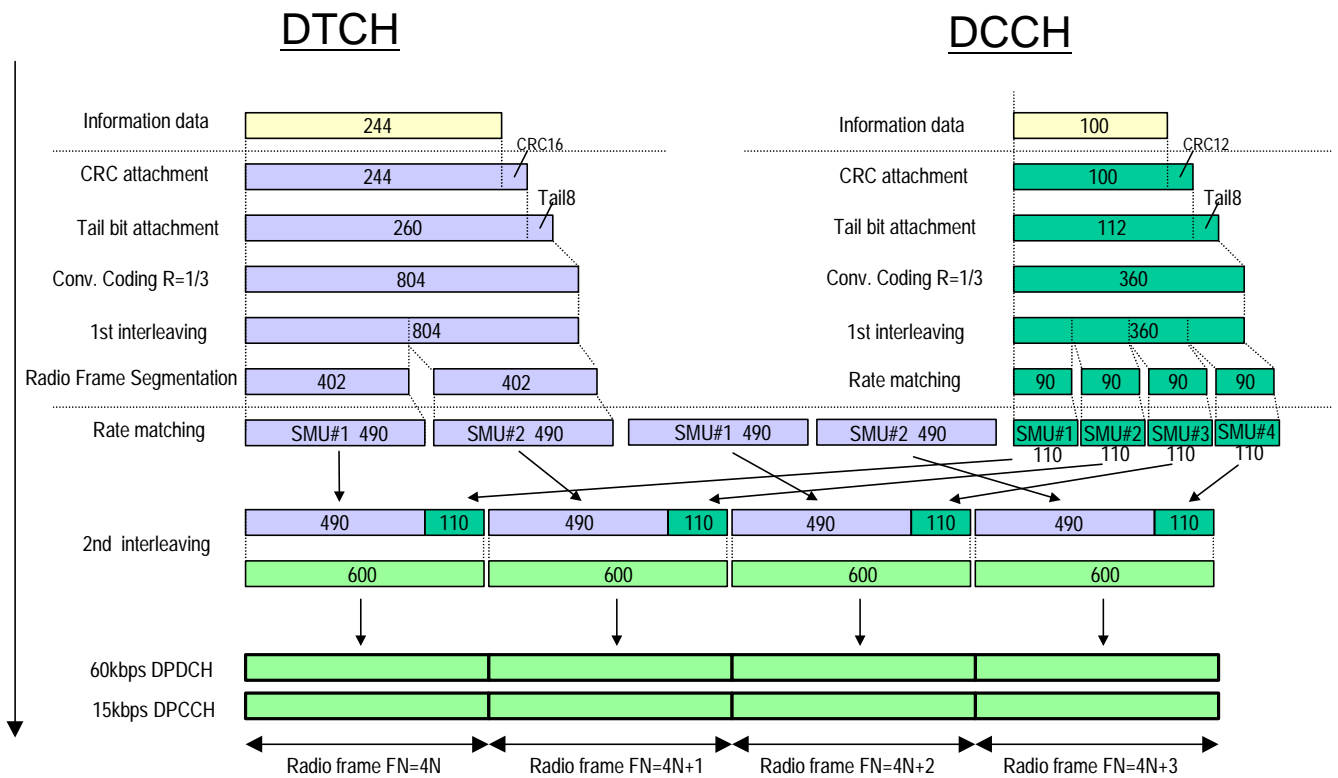

Figure C.2.1 (Informative): Channel coding of UL reference measurement channel (12.2 kbps)

C.2.2 UL reference measurement channel (64 kbps)

The parameters for the 64 kbps UL reference measurement channel are specified in Table C.2.2.1 and Table C.2.2.2. The channel coding for information is shown in Figure C.2.2. This measurement channel is not currently used in the present document but can be used for future requirements.

Table C.2.2.1: UL reference measurement channel (64 kbps)

Parameter	Level	Unit
Information bit rate	64	kbps
DPDCH	240	kbps
DPCCH	15	kbps
DPCCH Slot Format #i	0	-
DPCCH/DPDCH	-9.54	dB
TFCI	On	-
Repetition	18	%

Table C.2.2.2: UL reference measurement channel, transport channel parameters (64 kbps)

Parameter	DTCH	DCCH
Transport Channel Number	1	2
Transport Block Size	1280	100
Transport Block Set Size	1280	100
Transmission Time Interval	20 ms	40 ms
Type of Error Protection	Turbo Coding	Convolution Coding
Coding Rate	1/3	1/3
Rate Matching attribute	256	256
Size of CRC	16	12

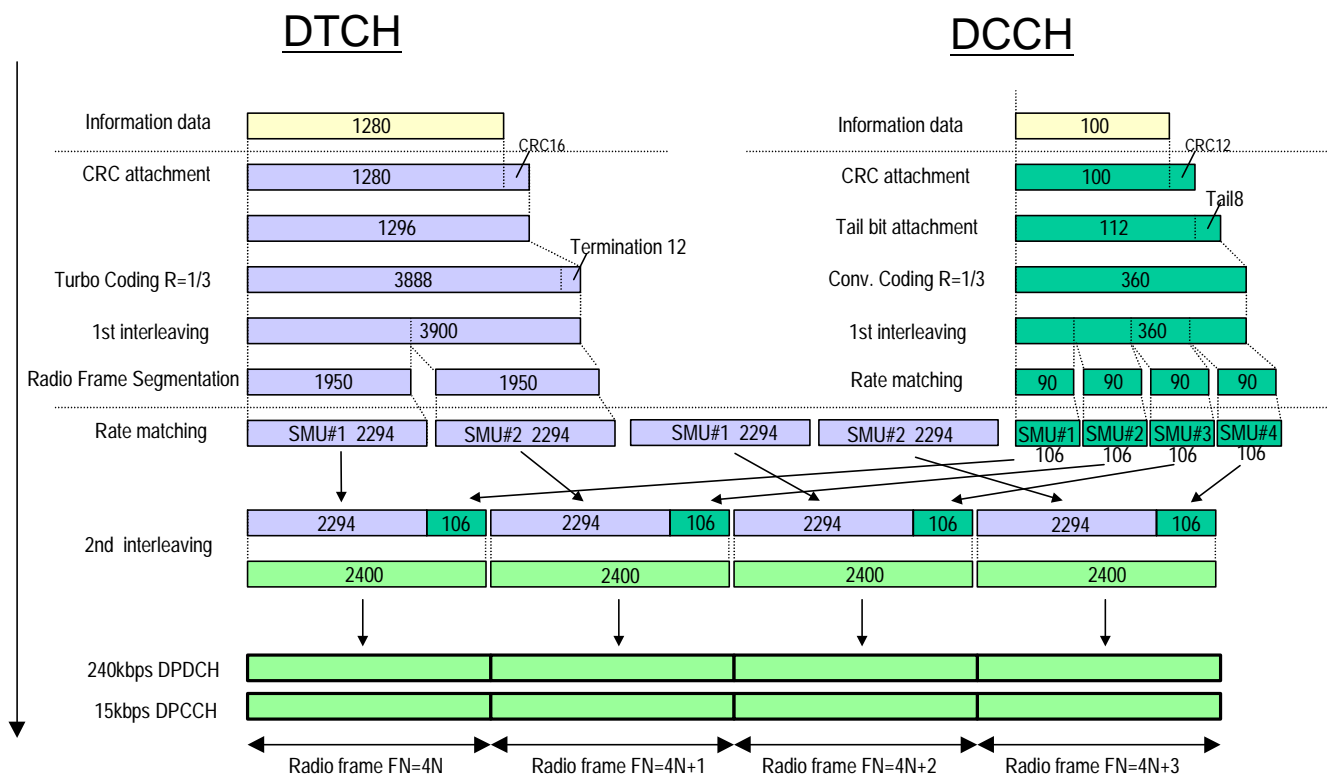

Figure C.2.2 (Informative): Channel coding of UL reference measurement channel (64 kbps)

C.2.3 UL reference measurement channel (144 kbps)

The parameters for the 144 kbps UL reference measurement channel are specified in Table C.2.3.1 and Table C.2.3.2. The channel coding for information is shown in Figure C.2.3. This measurement channel is not currently used in the present document but can be used for future requirements.

Table C.2.3.1: UL reference measurement channel (144 kbps)

Parameter	Level	Unit
Information bit rate	144	kbps
DPDCH	480	kbps
DPCCH	15	kbps
DPCCH Slot Format #i	0	-
DPCCH/DPDCH power ratio	-11.48	dB
TFCI	On	-
Repetition	8	%

Table C.2.3.2: UL reference measurement channel, transport channel parameters (144 kbps)

Parameters	DTCH	DCCH
Transport Channel Number	1	2
Transport Block Size	2880	100
Transport Block Set Size	2880	100
Transmission Time Interval	20 ms	40 ms
Type of Error Protection	Turbo Coding	Convolution Coding
Coding Rate	1/3	1/3
Rate Matching attribute	256	256
Size of CRC	16	12

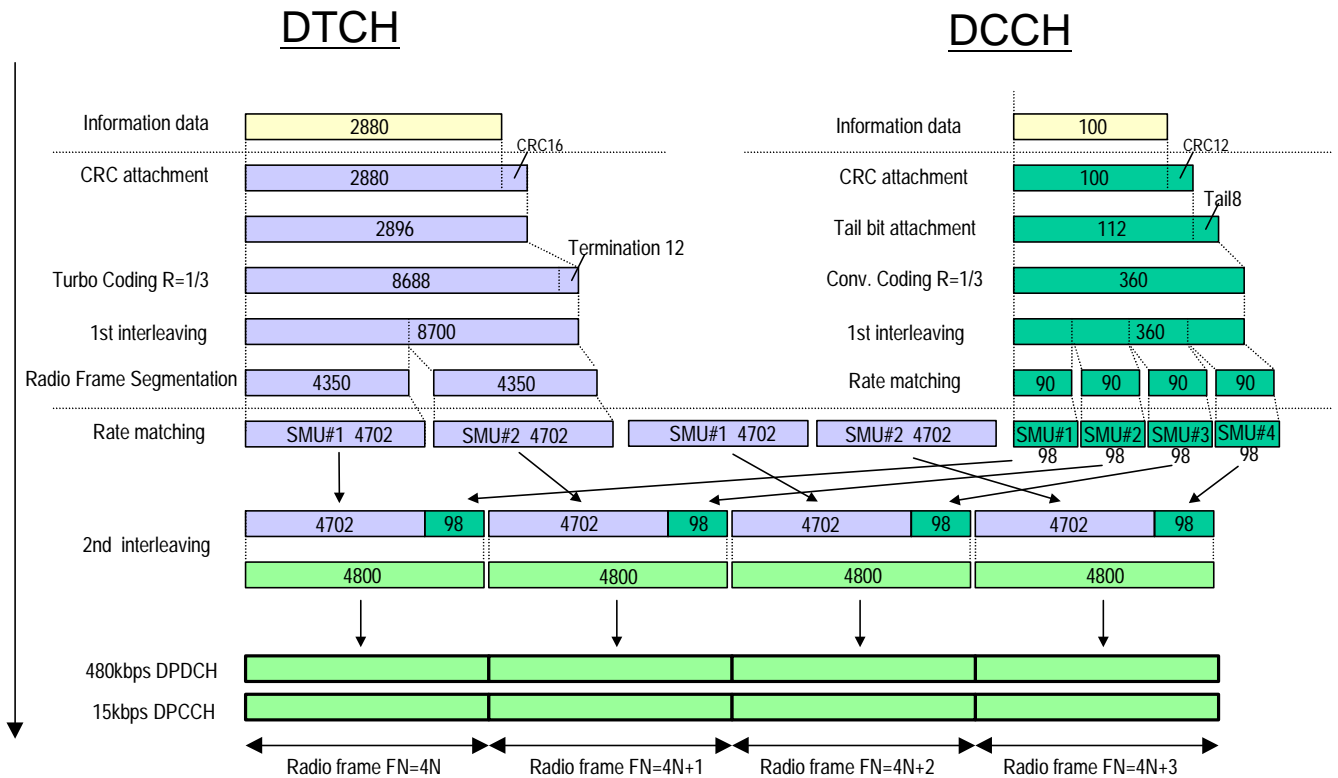

Figure C.2.3 (Informative): Channel coding of UL reference measurement channel (144 kbps)

C.2.4 UL reference measurement channel (384 kbps)

The parameters for the 384 kbps UL reference measurement channel are specified in Table C.2.4.1 and Table C.2.4.2. The channel coding for information is shown in Figure C.2.4. This measurement channel is not currently used in the present document but can be used for future requirements.

Table C.2.4.1: UL reference measurement channel (384 kbps)

Parameter	Level	Unit
Information bit rate	384	kbps
DPDCH	960	kbps
DPCCH	15	kbps
DPCCH/DPDCH power ratio	-11.48	dB
TFCI	On	-
Puncturing	18	%

Table C.2.4.2: UL reference measurement channel, transport channel parameters (384 kbps)

Parameter	DTCH	DCCH
Transport Channel Number	1	2
Transport Block Size	3840	100
Transport Block Set Size	3840	100
Transmission Time Interval	10 ms	40 ms
Type of Error Protection	Turbo Coding	Convolution Coding
Coding Rate	1/3	1/3
Rate Matching attribute	256	256
Size of CRC	16	12

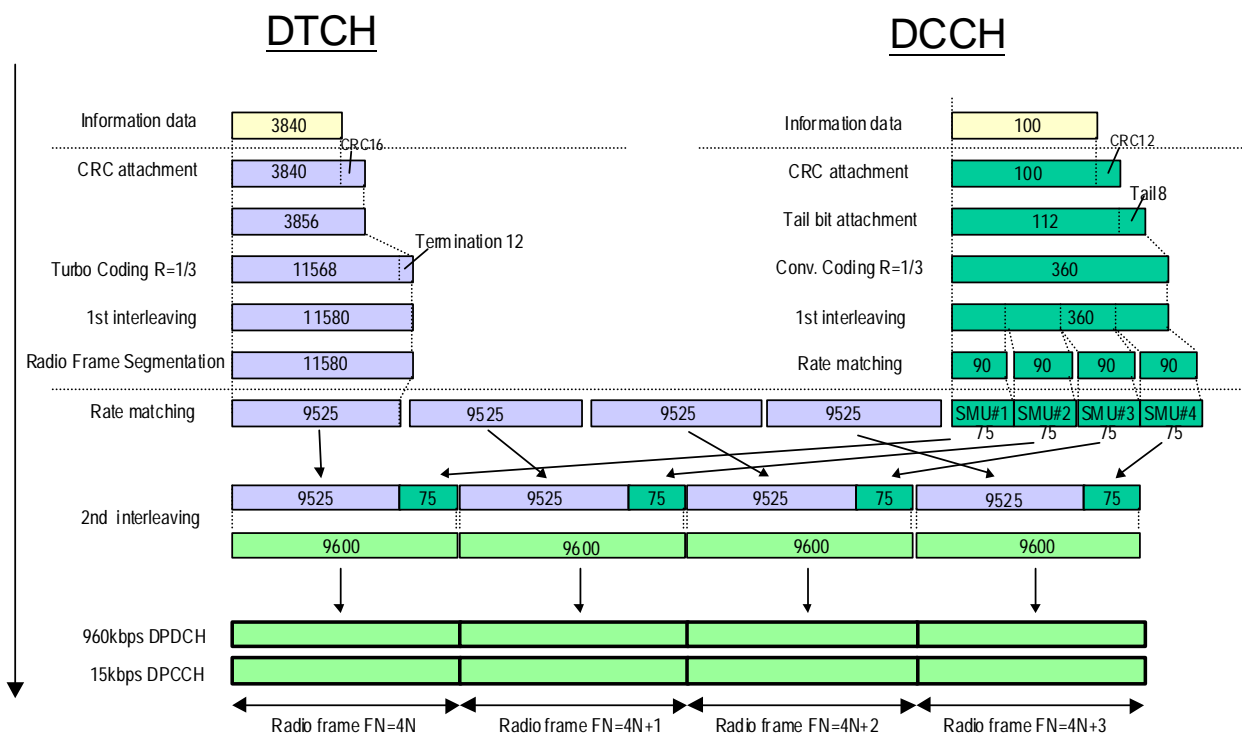

Figure C.2.4 (Informative): Channel coding of UL reference measurement channel (384 kbps)

C.2.5 UL reference measurement channel (768 kbps)

The parameters for the UL measurement channel for 768 kbps are specified in Table C.2.5.1 and Table C.2.5.2.

Table C.2.5.1: UL reference measurement channel, physical parameters (768 kbps)

Parameter	Level	Unit
Information bit rate	2*384	kbps
DPDCH ₁	960	kbps
DPDCH ₂	960	kbps
DPCCH	15	kbps
DPCCH/DPDCH power ratio	-11.48	dB
TFCI	On	-
Puncturing	18	%

Table C.2.5.2: UL reference measurement channel, transport channel parameters (768 kbps)

Parameter	DTCH	DCCH
Transport Channel Number	1	2
Transport Block Size	3840	100
Transport Block Set Size	7680	100
Transmission Time Interval	10 ms	40 ms
Type of Error Protection	Turbo Coding	Convolution Coding
Coding Rate	1/3	1/3
Rate Matching attribute	256	256
Size of CRC	16	12

C.3 DL reference measurement channel

C.3.1 DL reference measurement channel (12.2 kbps)

The parameters for the 12.2 kbps DL reference measurement channel are specified in Table C.3.1 and Table C.3.2. The channel coding is detailed in Figure C.3.1.

Table C.3.1: DL reference measurement channel (12.2 kbps)

Parameter	Level	Unit
Information bit rate	12.2	kbps
DPCH	30	ksps
Slot Format #i	11	-
TFCI	On	
Power offsets PO1, PO2 and PO3	0	dB
Puncturing	14.7	%

Table C.3.2: DL reference measurement channel, transport channel parameters (12.2 kbps)

Parameter	DTCH	DCCH
Transport Channel Number	1	2
Transport Block Size	244	100
Transport Block Set Size	244	100
Transmission Time Interval	20 ms	40 ms
Type of Error Protection	Convolution Coding	Convolution Coding
Coding Rate	1/3	1/3
Rate Matching attribute	256	256
Size of CRC	16	12
Position of TrCH in radio frame	fixed	fixed

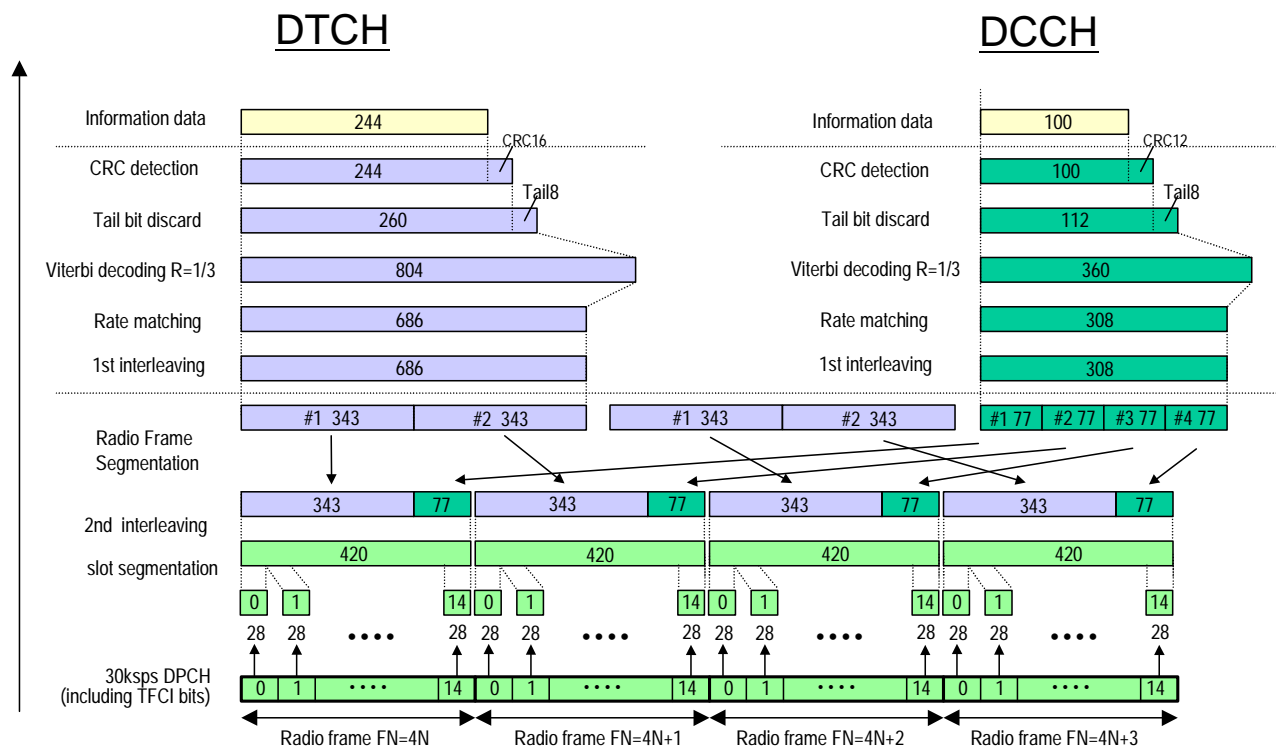

Figure C.3.1 (Informative): Channel coding of DL reference measurement channel (12.2 kbps)

C.3.2 DL reference measurement channel (64 kbps)

The parameters for the DL reference measurement channel for 64 kbps are specified in Table C.3.3 and Table C.3.4. The channel coding is detailed in Figure C.3.2.

Table C.3.3: DL reference measurement channel (64 kbps)

Parameter	Level	Unit
Information bit rate	64	kbps
DPCH	120	ksps
Slot Format #i	13	-
TFCI	On	-
Power offsets PO1, PO2 and PO3	0	dB
Repetition	2.9	%

Table C.3.4: DL reference measurement channel, transport channel parameters (64 kbps)

Parameter	DTCH	DCCH
Transport Channel Number	1	2
Transport Block Size	1280	100
Transport Block Set Size	1280	100
Transmission Time Interval	20 ms	40 ms
Type of Error Protection	Turbo Coding	Convolution Coding
Coding Rate	1/3	1/3
Rate Matching attribute	256	256
Size of CRC	16	12
Position of TrCH in radio frame	fixed	fixed

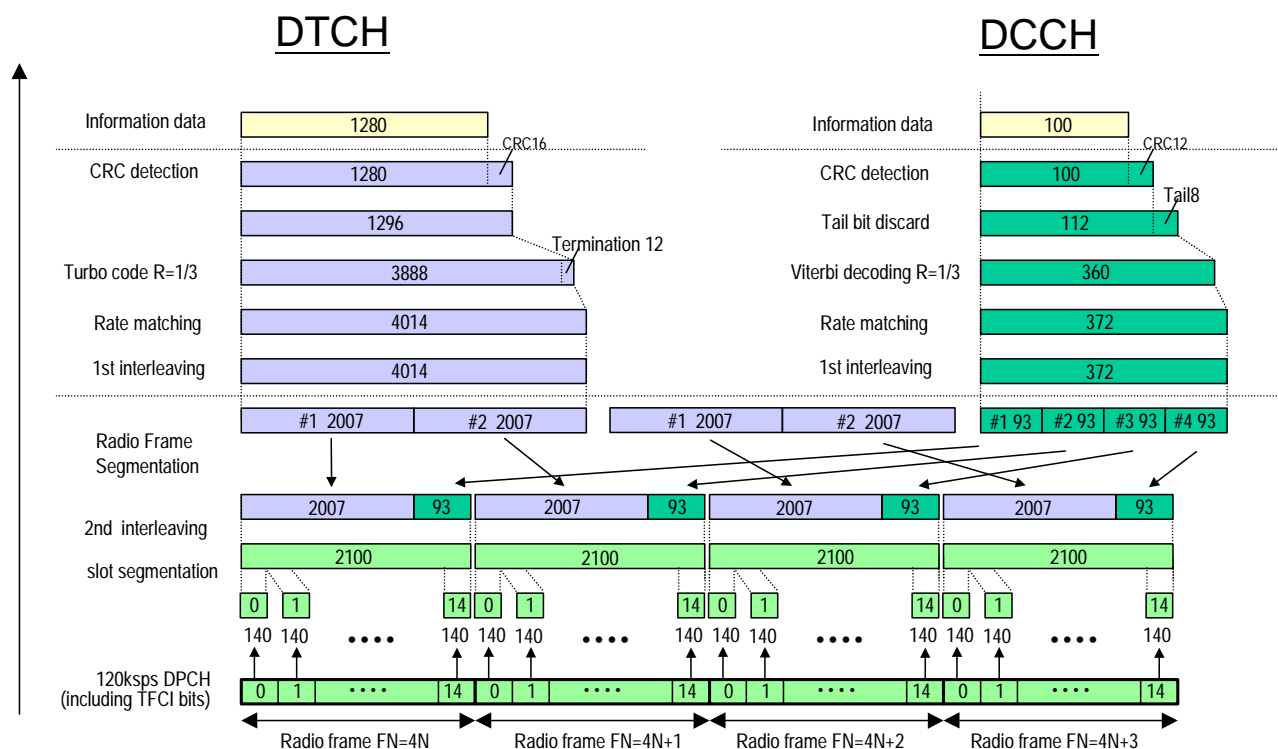

Figure C.3.2 (Informative): Channel coding of DL reference measurement channel (64 kbps)

C.3.3 DL reference measurement channel (144 kbps)

The parameters for the DL reference measurement channel for 144 kbps are specified in Table C.3.5 and Table C.3.6. The channel coding is detailed in Figure C.3.3.

Table C.3.5: DL reference measurement channel (144kbps)

Parameter	Level	Unit
Information bit rate	144	kbps
DPCH	240	ksps
Slot Format #i	14	-
TFCI	On	
Power offsets PO1, PO2 and PO3	0	dB
Puncturing	2.7	%

Table C.3.6: DL reference measurement channel, transport channel parameters (144 kbps)

Parameter	DTCH	DCCH
Transport Channel Number	1	2
Transport Block Size	2880	100
Transport Block Set Size	2880	100
Transmission Time Interval	20 ms	40 ms
Type of Error Protection	Turbo Coding	Convolution Coding
Coding Rate	1/3	1/3
Rate Matching attribute	256	256
Size of CRC	16	12
Position of TrCH in radio frame	fixed	fixed

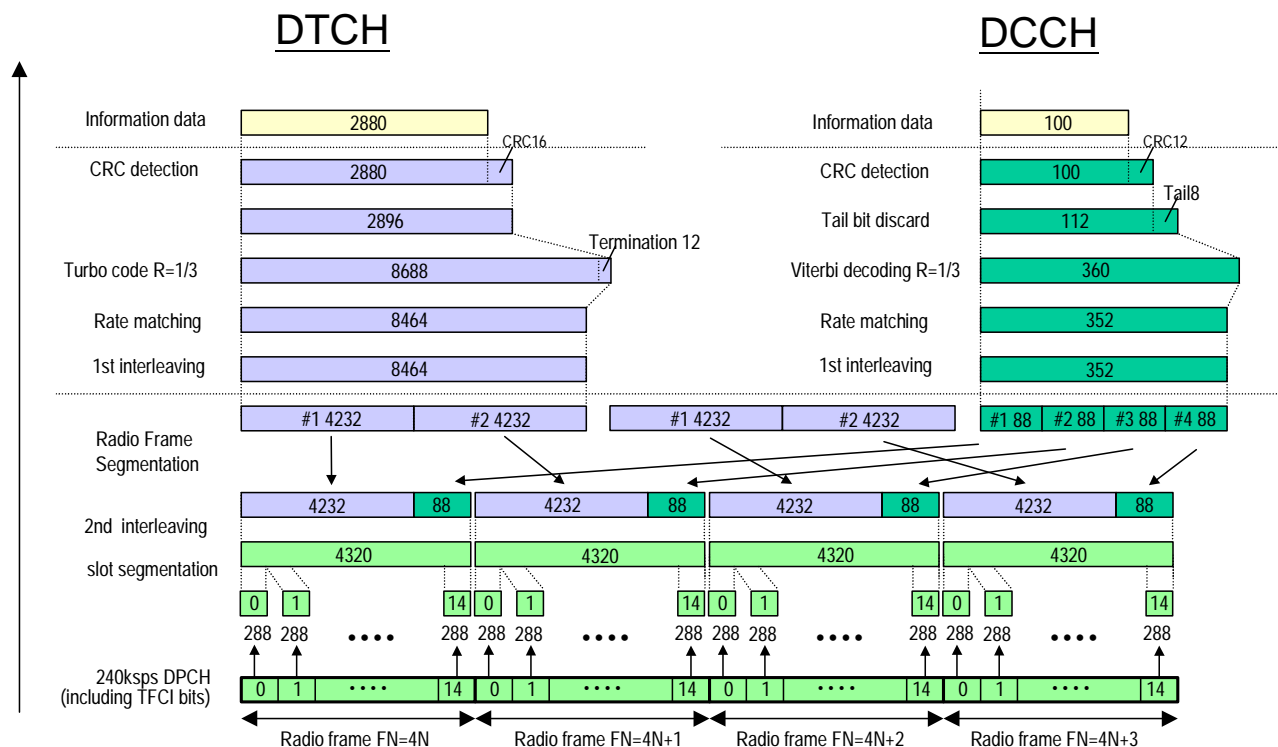

Figure C.3.3 (Informative): Channel coding of DL reference measurement channel (144 kbps)

C.3.4 DL reference measurement channel (384 kbps)

The parameters for the DL reference measurement channel for 384 kbps are specified in Table C.3.4.1 and Table C.3.4.2. The channel coding is shown for information in Figure C3.4.

Table C.3.4.1: DL reference measurement channel, physical parameters (384 kbps)

Parameter	Level	Unit
Information bit rate	384	kbps
DPCH	480	ksps
Slot Format #i	15	-
TFCI	On	-
Power offsets PO1, PO2 and PO3	0	dB
Puncturing	22	%

Table C.3.4.2: DL reference measurement channel, transport channel parameters (384 kbps)

Parameter	DTCH	DCCH
Transport Channel Number	1	2
Transport Block Size	3840	100
Transport Block Set Size	3840	100
Transmission Time Interval	10 ms	40 ms
Type of Error Protection	Turbo Coding	Convolution Coding
Coding Rate	1/3	1/3
Rate Matching attribute	256	256
Size of CRC	16	12
Position of TrCH in radio frame	fixed	Fixed

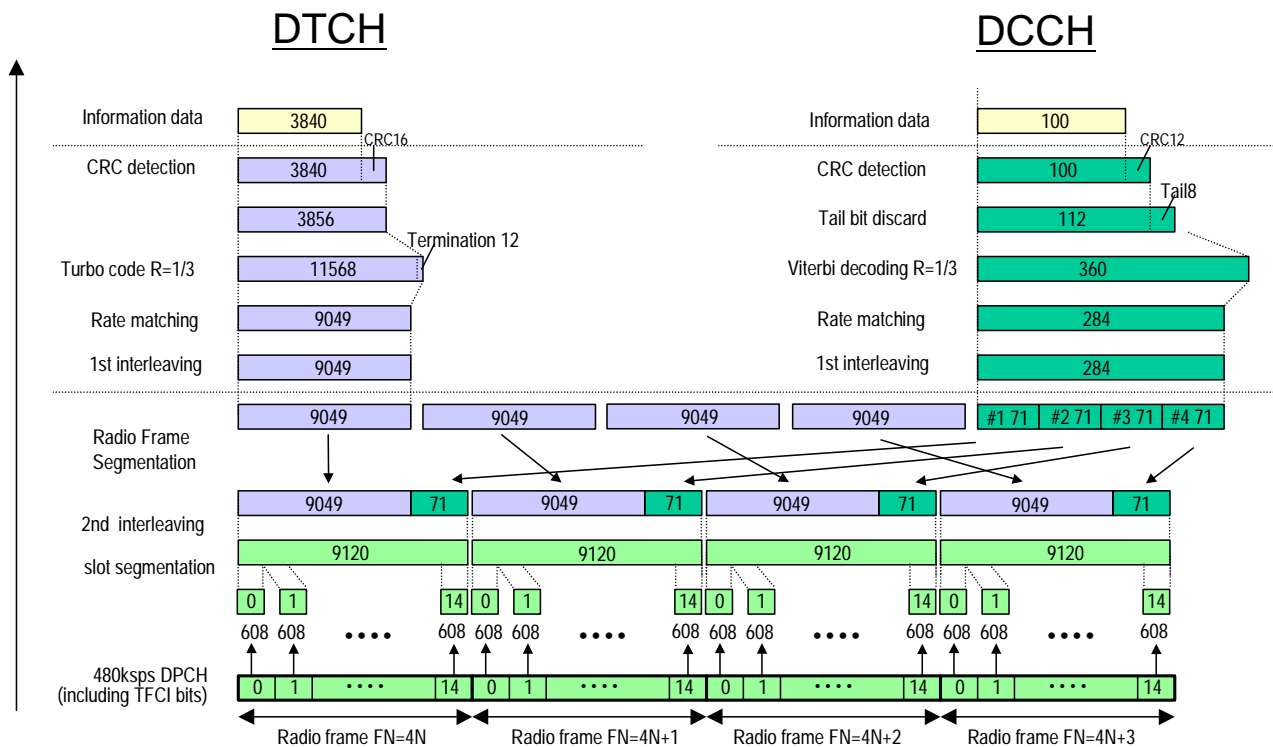

Figure C.3.4 (Informative): Channel coding of DL reference measurement channel (384 kbps)

C.4 Reference measurement channel for BTFD performance requirements

C.4.1 UL reference measurement channel for BTFD performance requirements

The parameters for UL reference measurement channel for BTFD are specified in Table C.4.1, Table C.4.2 and Table C.4.2.A.

Table C.4.1: UL reference measurement channel physical parameters for BTFD

Parameter	Level									Unit
	Rate1	Rate2	Rate3	Rate4	Rate5	Rate6	Rate7	Rate8	Rate9	
Information bit rate	12.8k	10.8k	8.55	8.0k	7.3k	6.5k	5.75k	5.35k	2.55k	kbps
DPCCH	15									kbps
DPCCH Slot Format #i	0									-
DPCCH/DPDCH power ratio	-5.46	-5.46	-5.46	-5.46	-5.46	-2.69	-2.69	-2.69	-2.69	dB
TFCI	On									-

Table C.4.2: UL reference measurement channel, transport channel parameters for BTFD

Parameters	DTCH									DCCH
	Rate1	Rate2	Rate3	Rate4	Rate5	Rate6	Rate7	Rate8	Rate9	
Transport Channel Number	1									2
Transport Block Size	256	216	171	160	146	130	115	107	51	100
Transport Block Set Size	256	216	171	160	146	130	115	107	51	100
Transmission Time Interval	20 ms									40 ms
Type of Error Protection	Convolution Coding									Convolution Coding
Coding Rate	1/3									1/3
Rate Matching Attribute	256									256
Size of CRC	0									12

Table C.4.2.A: Physical channel parameters

Min spreading factor	64
Max number of DPDCH data bits/radio frame	600
Puncturing Limit	1

C.4.2 DL reference measurement channel for BTFD performance requirements

The parameters for DL reference measurement channel for BTFD are specified in Table C.4.3 and Table C.4.4. The channel coding for information is shown in Figures C.4.1, C.4.2, and C.4.3.

Table C.4.3: DL reference measurement channel physical parameters for BTFD

Parameter	Rate 1	Rate 2	Rate 3	Unit
Information bit rate	12.2	7.95	1.95	kbps
DPCH	30			ksps
Slot Format #i	8			-
TFCI	Off			-
Power offsets PO1, PO2 and PO3	0			dB
Repetition	5			%

Table C.4.4: DL reference measurement channel, transport channel parameters for BTFD

Parameter	DTCH			DCCH
	Rate 1	Rate 2	Rate 3	
Transport Channel Number	1			2
Transport Block Size	244	159	39	100
Transport Block Set Size	244	159	39	100
Transmission Time Interval	20 ms			40 ms
Type of Error Protection	Convolution Coding			Convolution Coding
Coding Rate	1/3			1/3
Rate Matching attribute	256			256
Size of CRC	12			12
Position of TrCH in radio frame	fixed			fixed

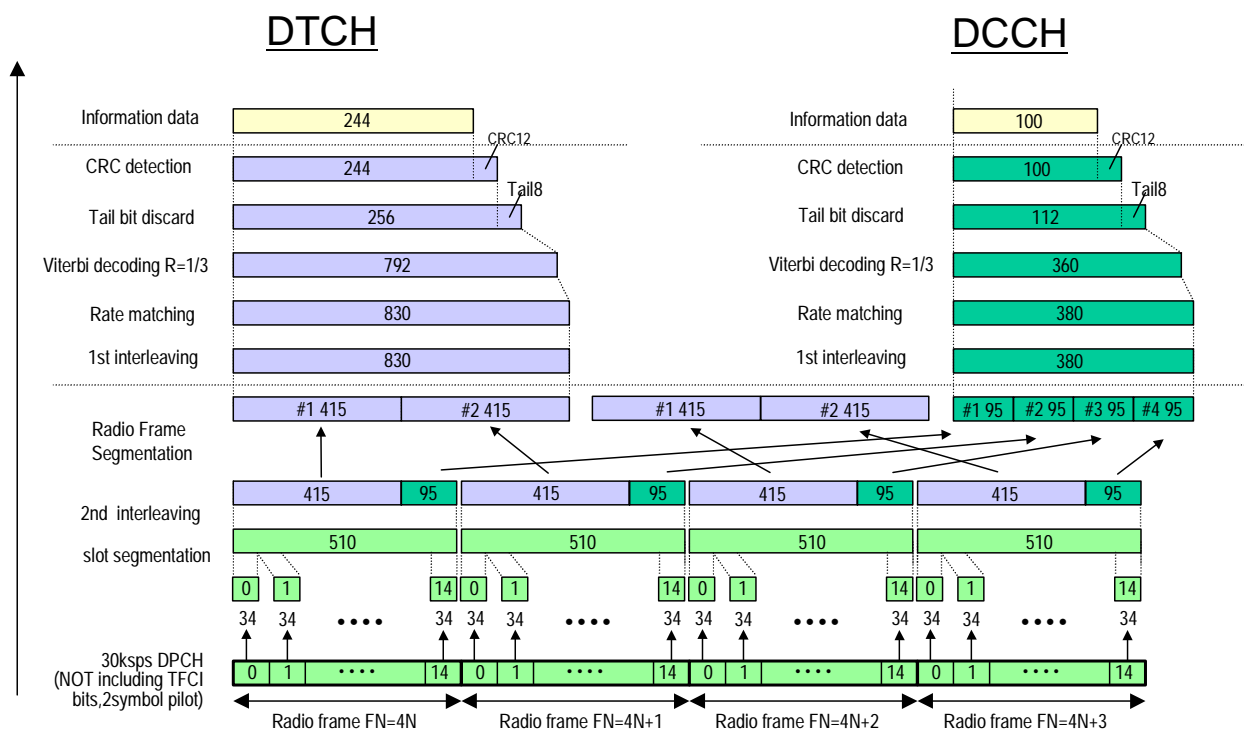

Figure C.4.1 (Informative): Channel coding of DL reference measurement channel for BTFD (Rate 1)

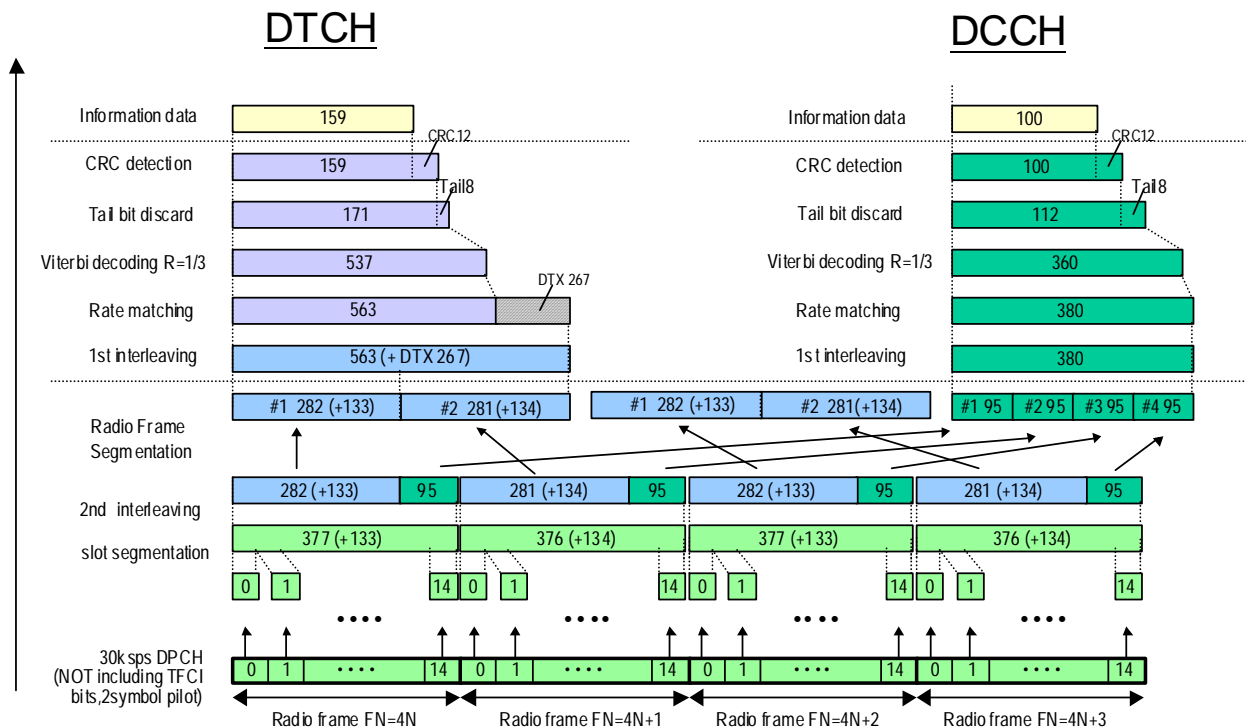

Figure C.4.2 (Informative): Channel coding of DL reference measurement channel for BTFD (Rate 2)

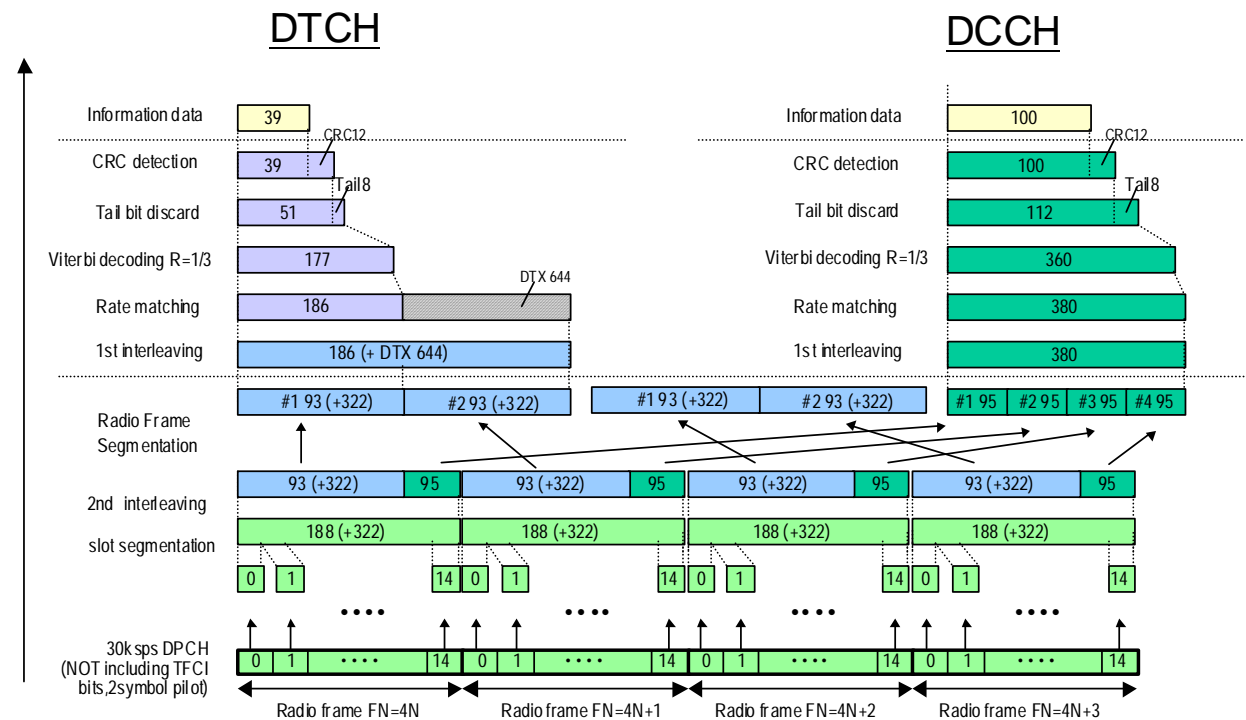

Figure C.4.3 (Informative): Channel coding of DL reference measurement channel for BTFD (Rate 3)

C.5 DL reference compressed mode parameters

Parameters described in Table C.5.1 are used in some test specified in TS 25.101 while parameters described in Table C.5.2 are used in some tests specified in TS 25.133.

Set 1 parameters in Table C.5.1 are applicable when compressed mode by spreading factor reduction is used in downlink. Set 2 parameters in Table C.5.1 are applicable when compressed mode by puncturing is used in downlink.

Table C.5.1: Compressed mode reference pattern 1 parameters

Parameter	Set 1	Set 2	Note
TGSN (Transmission Gap Starting Slot Number)	11	11	
TGL1 (Transmission Gap Length 1)	7	7	
TGL2 (Transmission Gap Length 2)	-	-	Only one gap in use.
TGD (Transmission Gap Distance)	0	0	Only one gap in use.
TGPL1 (Transmission Gap Pattern Length)	2	4	
TGPL2 (Transmission Gap Pattern Length)	-	-	Only one pattern in use.
TGPRC (Transmission Gap Pattern Repetition Count)	NA	NA	Defined by higher layers
TGCFN (Transmission Gap Connection Frame Number):	NA	NA	Defined by higher layers
UL/DL compressed mode selection	DL & UL	DL & UL	2 configurations possible DL & UL / DL
UL compressed mode method	SF/2	SF/2	
DL compressed mode method	SF/2	Puncturing	
Downlink frame type and Slot format	11B	11A	
Scrambling code change	No	No	
RPP (Recovery period power control mode)	0	0	
ITP (Initial transmission power control mode)	0	0	

Table C.5.2: Compressed mode reference pattern 2 parameters

Parameter	Set 1	Set 2	Note
TGSN (Transmission Gap Starting Slot Number)	4	4	
TGL1 (Transmission Gap Length 1)	7	7	
TGL2 (Transmission Gap Length 2)	-	-	Only one gap in use.
TGD (Transmission Gap Distance)	0	0	
TGPL1 (Transmission Gap Pattern Length)	3	12	
TGPL2 (Transmission Gap Pattern Length)	-	-	Only one pattern in use.
TGPRC (Transmission Gap Pattern Repetition Count)	NA	NA	Defined by higher layers
TGCFN (Transmission Gap Connection Frame Number):	NA	NA	Defined by higher layers
UL/DL compressed mode selection	DL & UL	DL & UL	2 configurations possible. DL & UL / DL
UL compressed mode method	SF/2	SF/2	
DL compressed mode method	SF/2	SF/2	
Downlink frame type and Slot format	11B	11B	
Scrambling code change	No	No	
RPP (Recovery period power control mode)	0	0	
ITP (Initial transmission power control mode)	0	0	

Annex D (normative): Propagation Conditions

D.1 General

D.2 Propagation Conditions

D.2.1 Static propagation condition

The propagation for the static performance measurement is an Additive White Gaussian Noise (AWGN) environment. No fading and multi-paths exist for this propagation model.

D.2.2 Multi-path fading propagation conditions

Table D.2.2.1 shows propagation conditions that are used for the performance measurements in multi-path fading environment. All taps have classical Doppler spectrum.

Table D.2.2.1: Propagation condition for multi-path fading environments

Case 1, speed 3km/h		Case 2, speed 3 km/h		Case 3, 120 km/h		Case 4, 3 km/h		Case 5, 50 km/h	
Relative Delay [ns]	Average Power [dB]	Relative Delay [ns]	Average Power [dB]	Relative Delay [ns]	Average Power [dB]	Relative Delay [ns]	Average Power [dB]	Relative Delay [ns]	Average Power [dB]
0	0	0	0	0	0	0	0	0	0
976	-10	976	0	260	-3	976	0	976	-10
		20000	0	521	-6				
				781	-9				

Note Case 5 is only used in Requirements for support of RRM.

D.2.3 Moving propagation conditions

The dynamic propagation conditions for the test of the baseband performance are non fading channel models with two taps. The moving propagation condition has two taps, one static, Path0, and one moving, Path1. The time difference between the two paths is according Equation D.2.3.1. The taps have equal strengths and equal phases.

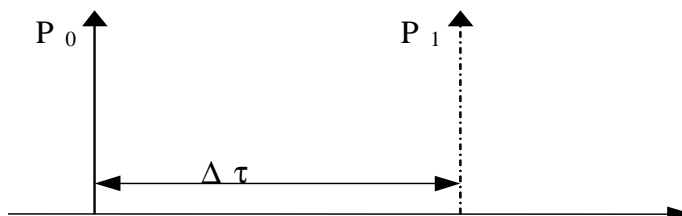

Figure D.2.3.1: The moving propagation conditions

$$\Delta\tau = B + \frac{A}{2}(1 + \sin(\Delta\omega \cdot t))$$

Equation D.2.3.1

The parameters in the equation are shown in.

A	5 μ s
B	1 μ s
$\Delta\omega$	$40 \cdot 10^{-3} \text{ s}^{-1}$

D.2.4 Birth-Death propagation conditions

The dynamic propagation conditions for the test of the baseband performance is a non fading propagation channel with two taps. The moving propagation condition has two taps, Path1 and Path2 while alternate between 'birth' and 'death'. The positions the paths appear are randomly selected with an equal probability rate and are shown in Figure D.2.4.1.

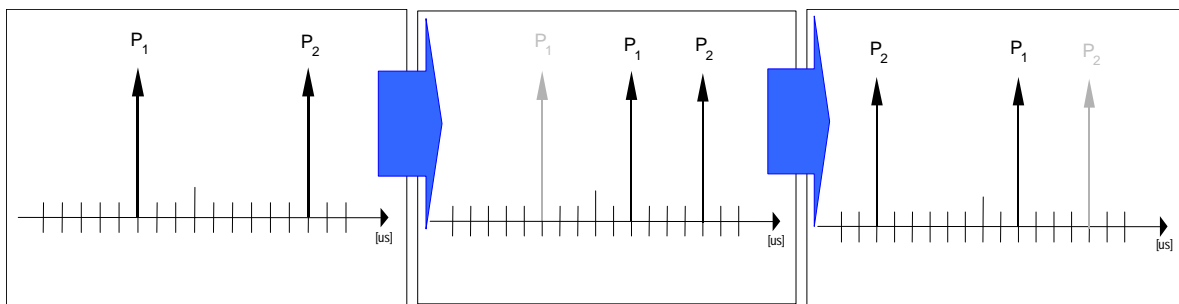

Figure D.2.4.1: Birth death propagation sequence

NOTE:

1. Two paths, Path1 and Path2 are randomly selected from the group [-5, -4, -3, -2, -1, 0, 1, 2, 3, 4, 5] μ s. The paths have equal strengths and equal phases.
2. After 191 ms, Path1 vanishes and reappears immediately at a new location randomly selected from the group [-5, -4, -3, -2, -1, 0, 1, 2, 3, 4, 5] μ s but excludes the point Path2.
3. After additional 191 ms, Path2 vanishes and reappears immediately at a new location randomly selected from the group [-5, -4, -3, -2, -1, 0, 1, 2, 3, 4, 5] μ s but excludes the point Path1.
4. The sequence in 2) and 3) is repeated.

Annex E (normative): Downlink Physical Channels

E.1 General

This normative annex specifies the downlink physical channels that are needed for setting a connection and channels that are needed during a connection.

E.2 Connection Set-up

Table E.2.1 describes the downlink Physical Channels that are required for connection set up.

Table E.2.1: Downlink Physical Channels required for connection set-up

Physical Channel
CPICH
P-CCPCH
SCH
S-CCPCH
PICH
AICH
DPCH

E.2.1 Measurement without dedicated connection

Table E.2.2 describes the downlink Physical Channels that are required for measurement before connection. This is applicable for the subclauses 5.4.1 (Open Loop Power Control in the Uplink), and 5.5.2 (Transmit ON/OFF Time mask).

Table E.2.2: Downlink Physical Channels transmitted without dedicated connection

Physical Channel	Power
\hat{I}_{or}	Test dependent power
CPICH	$CPICH_{Ec} / I_{or} = -3.3$ dB
P-CCPCH	$P-CCPCH_{Ec} / I_{or} = -5.3$ dB
SCH	$SCH_{Ec} / I_{or} = -5.3$ dB
PICH	$PICH_{Ec} / I_{or} = -8.3$ dB
S-CCPCH	$S-CCPCH_{Ec} / I_{or} = -10.3$ dB

E.3 During connection

The following clauses describe the downlink Physical Channels that are transmitted during a connection i.e., when measurements are done. For these measurements the offset between DPCH and SCH shall be zero chips at base station meaning that SCH is overlapping with the first symbols in DPCH in the beginning of DPCH slot structure.

E.3.1 Measurement of Tx Characteristics

Table E.3.1 is applicable for measurements on the Transmitter Characteristics (clause 5) with the exception of subclauses 5.3 (Frequency Error), 5.4.1 (Open Loop Power Control in the Uplink), 5.4.4 (Out-of-synchronisation handling of output power), and 5.5.2 (Transmit ON/OFF Time mask).

NOTE: Applicability to subclause 5.7 (Power setting in uplink compressed mode) is FFS.

Table E.3.1: Downlink Physical Channels transmitted during a connection

Physical Channel	Power
for	-93 dBm / 3.84MHz
CPICH	CPICH_Ec / DPCH_Ec = 7 dB
P-CCPCH	P-CCPCH_Ec / DPCH_Ec = 5 dB
SCH	SCH_Ec / DPCH_Ec = 5 dB
PICH	PICH_Ec / DPCH_Ec = 2 dB
DPCH	-103.3 dBm / 3.84MHz

E.3.2 Measurement of Rx Characteristics

Table E.3.2 is applicable for measurements on the Receiver Characteristics (clause 6) with the exception of subclause 6.3 (Maximum input level), and 6.8 (Spurious Emissions).

Table E.3.2: Downlink Physical Channels transmitted during a connection

Physical Channel	Power
CPICH	CPICH_Ec / DPCH_Ec = 7 dB
P-CCPCH	P-CCPCH_Ec / DPCH_Ec = 5 dB
SCH	SCH_Ec / DPCH_Ec = 5 dB
PICH	PICH_Ec / DPCH_Ec = 2 dB
DPCH	Test dependent power

E.3.3 Measurement of Performance requirements

Table E.3.3 is applicable for measurements on the Performance requirements (clause 7), including subclause 6.3 (Maximum input level), excluding subclauses 7.6.1 (Demodulation of DCH in open loop transmit diversity mode) and 7.6.2 (Demodulation of DCH in closed loop transmit diversity mode).

Table E.3.3: Downlink Physical Channels transmitted during a connection¹

Physical Channel	Power	Note
P-CPICH	$P\text{-CPICH_Ec/Ior} = -10 \text{ dB}$	Use of P-CPICH or S-CPICH as phase reference is specified for each requirement and is also set by higher layer signalling.
S-CPICH	$S\text{-CPICH_Ec/Ior} = -10 \text{ dB}$	When S-CPICH is the phase reference in a test condition, the phase of S-CPICH shall be 180 degrees offset from the phase of P-CPICH. When S-CPICH is not the phase reference, it is not transmitted.
P-CCPCH	$P\text{-CCPCH_Ec/Ior} = -12 \text{ dB}$	
SCH	$SCH_Ec/Ior = -12 \text{ dB}$	This power shall be divided equally between Primary and Secondary Synchronous channels
PICH	$PICH_Ec/Ior = -15 \text{ dB}$	
DPCH	Test dependent power	When S-CPICH is the phase reference in a test condition, the phase of DPCH shall be 180 degrees offset from the phase of P-CPICH.
OCNS	Necessary power so that total transmit power spectral density of Node B (Ior) adds to one	OCNS interference consists of 16 dedicated data channels. The channelization codes, level settings and timing offsets for data channels are chosen as specified for the 16 DPCH channels of Test Model 1 in TS 25.141 [10] Table 6.2. All dedicated channels user data is uncorrelated to each other and the measurement channel during the BER/BLER measurement period.

¹ Power levels are based on the assumption that multipath propagation conditions and noise source representing interference from other cells Ioc are turned on after the call set-up phase.

E.3.4 Connection with open-loop transmit diversity mode

Table E.3.4 is applicable for measurements for subclause 7.6.1 (Demodulation of DCH in open loop transmit diversity mode)

Table E.3.4: Downlink Physical Channels transmitted during a connection²

Physical Channel	Power	Note
P-CPICH (antenna 1)	$P\text{-CPICH_}E_{c1}/I_{or} = -13 \text{ dB}$	1. Total $P\text{-CPICH_}E_c/I_{or} = -10 \text{ dB}$
P-CPICH (antenna 2)	$P\text{-CPICH_}E_{c2}/I_{or} = -13 \text{ dB}$	
P-CPICH (antenna 1)	$P\text{-CPICH_}E_{c1}/I_{or} = -13 \text{ dB}$	1. Total $P\text{-CPICH_}E_c/I_{or} = -10 \text{ dB}$
P-CPICH (antenna 2)	$P\text{-CPICH_}E_{c2}/I_{or} = -13 \text{ dB}$	
P-CCPCH (antenna 1)	$P\text{-CCPCH_}E_{c1}/I_{or} = -15 \text{ dB}$	1. STTD applied
P-CCPCH (antenna 2)	$P\text{-CCPCH_}E_{c2}/I_{or} = -15 \text{ dB}$	2. Total $P\text{-CCPCH_}E_c/I_{or} = -12 \text{ dB}$
SCH (antenna 1 / 2)	$SCH_E_c/I_{or} = -12 \text{ dB}$	1. TSTD applied. 2. This power shall be divided equally between Primary and Secondary Synchronous channels
PICH (antenna 1)	$PICH_E_{c1}/I_{or} = -18 \text{ dB}$	1. STTD applied
PICH (antenna 2)	$PICH_E_{c2}/I_{or} = -18 \text{ dB}$	2. Total $PICH_E_c/I_{or} = -15 \text{ dB}$
DPCH	Test dependent power	1. STTD applied 2. Total power from both antennas
OCNS	Necessary power so that total transmit power spectral density of Node B (I_{or}) adds to one	1. This power shall be divided equally between antennas 2. OCNS interference consists of 16 dedicated data channels. The channelization codes, level settings and timing offsets for data channels are chosen as specified for the 16 DPCH channels of Test Model 1 in TS 25.141 [10] Table 6.2. All dedicated channels user data is uncorrelated to each other and the measurement channel during the BER/BLER measurement period.

² Power levels are based on the assumption that multipath propagation conditions and noise source representing interference from other cells I_{oc} are turned on after the call set-up phase.

E.3.5 Connection with closed loop transmit diversity mode

Table E.3.5 is applicable for measurements for subclause 7.6.2 (Demodulation of DCH in closed loop transmit diversity mode)

Table E.3.5: Downlink Physical Channels transmitted during a connection³

Physical Channel	Power	Note
P-CPICH (antenna 1)	$P\text{-CPICH_Ec1/lor} = -13 \text{ dB}$	1. Total P-CPICH_Ec/lor = -10 dB
P-CPICH (antenna 2)	$P\text{-CPICH_Ec2/lor} = -13 \text{ dB}$	
P-CCPCH (antenna 1)	$P\text{-CCPCH_Ec1/lor} = -15 \text{ dB}$	1. STTD applied
P-CCPCH (antenna 2)	$P\text{-CCPCH_Ec2/lor} = -15 \text{ dB}$	1. STTD applied, total P-CCPCH_Ec/lor = -12 dB
SCH (antenna 1 / 2)	$SCH_Ec/lor = -12 \text{ dB}$	1. TSTD applied
PICH (antenna 1)	$PICH_Ec1/lor = -18 \text{ dB}$	1. STTD applied 2. STTD applied, total PICH_Ec/lor = -15 dB
PICH (antenna 2)	$PICH_Ec2/lor = -18 \text{ dB}$	
DPCH	Test dependent power	1. Total power from both antennas
OCNS	Necessary power so that total transmit power spectral density of Node B (lor) adds to one	1. This power shall be divided equally between antennas 2. OCNS interference consists of 16 dedicated data channels. The channelization codes, level settings and timing offsets for data channels are chosen as specified for the 16 DPCH channels of Test Model 1 in TS 25.141 [10] Table 6.2. All dedicated channels user data is uncorrelated to each other and the measurement channel during the BER/BLER measurement period.

³ Power levels are based on the assumption that multipath propagation conditions and noise source representing interference from other cells Ioc are turned on after the call set-up phase.

Annex F (normative): General test conditions and declarations

The requirements of this clause apply to all applicable tests in this specification.

Many of the tests in this specification measure a parameter relative to a value that is not fully specified in the UE specifications. For these tests, the Minimum Requirement is determined relative to a nominal value specified by the manufacturer.

When specified in a test, the manufacturer shall declare the nominal value of a parameter, or whether an option is supported.

In all the relevant subclauses in this clause all Bit Error Ratio (BER), Block Error Ratio (BLER), False transmit format Detection Ratio (FDR) measurements shall be carried out according to the general rules for statistical testing in annex F.6.

F.1 Acceptable uncertainty of Test System

The maximum acceptable uncertainty of the Test System is specified below for each test, where appropriate. The Test System shall enable the stimulus signals in the test case to be adjusted to within the specified range, and the equipment under test to be measured with an uncertainty not exceeding the specified values. All ranges and uncertainties are absolute values, and are valid for a confidence level of 95 %, unless otherwise stated.

A confidence level of 95% is the measurement uncertainty tolerance interval for a specific measurement that contains 95% of the performance of a population of test equipment.

For RF tests it should be noted that the uncertainties in subclause F.1 apply to the Test System operating into a nominal 50 ohm load and do not include system effects due to mismatch between the DUT and the Test System.

F.1.1 Measurement of test environments

The measurement accuracy of the UE test environments defined in Annex G, Test environments shall be.

- Pressure ± 5 kPa.
- Temperature ± 2 degrees.
- Relative Humidity ± 5 %.
- DC Voltage $\pm 1,0$ %.
- AC Voltage $\pm 1,5$ %.
- Vibration 10 %.
- Vibration frequency 0,1 Hz.

The above values shall apply unless the test environment is otherwise controlled and the specification for the control of the test environment specifies the uncertainty for the parameter.

F.1.2 Measurement of transmitter

Table F.1.2 Maximum Test System Uncertainty for transmitter tests

Subclause	Maximum Test System Uncertainty
5.2 Maximum Output Power	±0.7 dB
5.3 Frequency Error	± 10 Hz
5.4.1 Open loop power control in uplink	±1.0 dB comprising: SQRT(source_level_error ² + power_meas_error ²)
5.4.2 Inner loop power control in the uplink – 1 dB	±[0.1] dB relative over a 1.5 dB range
5.4.2 Inner loop power control in the uplink – 10 dB	±[0.3] dB relative over a 12 dB range
5.4.3 Minimum Output Power	±1.0 dB
5.4.4 Out-of-synchronisation handling of output power: $\frac{DPCCH - E_c}{I_{or}}$	±[0.3] dB
5.4.4 Out-of-synchronisation handling of output power: transmit ON/OFF time	[0] ms
5.5.1 Transmit ON/OFF Power: UE minimum output power	±1.0 dB
5.5.2 Transmit ON/OFF Power: transmit ON/OFF time mask	TBD
5.6 Change of TFC: power control step size	TBD
5.6 Change of TFC: timing	TBD
5.7 Power setting in uplink compressed mode:-UE output power	TBD
5.8 Occupied Bandwidth	±100 kHz
5.9 Spectrum emission mask	±1.5 dB
5.10 ACLR	5 MHz offset: ± 0.8 dB 10 MHz offset: ± 0.8 dB
5.11 Spurious emissions	± 2.0 dB for UE and coexistence bands for results > -60 dBm ± 3.0 dB for results < -60 dBm Outside above: f ≤ 2.2GHz : ± 1.5 dB 2.2 GHz < f ≤ 4 GHz : ± 2.0 dB f > 4 GHz : ±4.0 dB
5.12 Transmit Intermodulation	Will be based on BS, need to work out freq and level ranges.
5.13 Transmit modulation: EVM	±2.5 % (for single code)
5.13 Transmit modulation: peak code domain error	±1.0dB

F.1.3 Measurement of receiver

Table F.1.3 Maximum Test System Uncertainty for receiver tests

Subclause	Maximum Test System Uncertainty
6.2 Reference sensitivity level	± 0.7 dB
6.3 maximum input level:	TBD
6.4 Adjacent channel selectivity	± 1.1 dB
6.5 Blocking characteristics	Using ± 0.7 dB for signal and interferer as currently defined, and 68 dB ACLR @ 10 MHz. System error with $f < 15$ MHz offset: ± 1.4 dB $f \geq 15$ MHz offset and $f_b \leq 2.2$ GHz: $\pm [1.0]$ dB 2.2 GHz $< f \leq 4$ GHz : $\pm [1.7]$ dB $f > 4$ GHz: $\pm [3.1]$ dB
6.6 Spurious Response	$f \leq 2.2$ GHz: ± 1.0 dB 2.2 GHz $< f \leq 4$ GHz : ± 1.7 dB $f > 4$ GHz: ± 3.1 dB
6.7 Intermodulation Characteristics	Assume ± 0.7 dB for all signals. Overall uncertainty = $\pm [0.6]$ dB Needs further analysis
6.8 Spurious emissions	± 3.0 dB for UE receive band (-78 dBm) Outside above: $f \leq 2.2$ GHz : ± 2.0 dB (-57 dBm) 2.2 GHz $< f \leq 4$ GHz : ± 2.0 dB (-47 dBm) $f > 4$ GHz : ± 4.0 dB (-47 dBm)

F.1.4 Performance requirement

Table F.1.4 Maximum Test System Uncertainty for Performance Requirements

Subclause	Maximum Test System Uncertainty
7.2 Demodulation in Static Propagation Condition	Need combination of the following three parameters \hat{I}_{or}/I_{oc} $\pm [0.5]$ dB I_{oc} $\pm [0.7]$ dB $\frac{DPCH - E_c}{I_{or}}$ $\pm [0.3]$ dB
7.3 Demodulation of DCH in multipath Fading Propagation conditions	Need combination of the following three parameters \hat{I}_{or}/I_{oc} $\pm [0.5]$ dB I_{oc} $\pm [1.0]$ dB $\frac{DPCH - E_c}{I_{or}}$ $\pm [0.3]$ dB
7.4 Demodulation of DCH in Moving Propagation conditions	As 7.3
7.5 Demodulation of DCH in Birth-Death Propagation conditions	As 7.3
7.6 Demodulation of DCH in Base Station Transmit diversity	As 7.3
7.7 Demodulation in Handover conditions	As 7.3
7.8 Power control in downlink	As 7.3
7.9 Downlink compressed mode	As 7.3
7.10 Blind transport format detection	As 7.3

F.1.5 Requirements for support of RRM

TBD

F.2 Test Tolerances (This subclause is informative)

The Test Tolerances defined in this subclause have been used to relax the Minimum Requirements in this specification to derive the Test Requirements.

The Test Tolerances are derived from Test System uncertainties, regulatory requirements and criticality to system performance. As a result, the Test Tolerances may sometimes be set to zero.

The test tolerances should not be modified for any reason e.g. to take account of commonly known test system errors (such as mismatch, cable loss, etc.).

F.2.1 Transmitter

Table F.2.1 Test Tolerances for transmitter tests.

Subclause	Test Tolerance
5.2 Maximum Output Power	0.7 dB
5.3 Frequency error	10 Hz
5.4.1 Open loop power control in uplink	
5.4.2 Inner loop power control in the uplink – 1 dB	
5.4.2 Inner loop power control in the uplink – 10 dB	
5.4.3 Minimum Output Power	1.0 dB
5.4.4 Out-of-synchronisation handling of output power: $\frac{DPCCH_E_c}{I_{or}}$	[0.3] dB
5.4.4 Out-of-synchronisation handling of output power: transmit ON/OFF time	0 ms
5.5.1 Transmit OFF power	1.0 dB
5.6 Change of TFC: power control step size	
5.6 Change of TFC: timing	
5.7 Power setting in uplink compressed mode:-UE output power	
5.8 Occupied Bandwidth	0 kHz
5.9 Spectrum emission mask	1.5 dB
5.10 ACLR	0.8 dB
5.11 Spurious emissions	0 dB
5.12 Transmit Intermodulation	0 dB
5.13.1 Transmit modulation: EVM	0%
5.13.2 Transmit modulation: peak code domain error	1.0 dB

F.2.2 Receiver

Table F.2.2 Test Tolerances for receiver tests.

Subclause	Test Tolerance
6.2 Reference sensitivity level	0.7 dB
6.3 Maximum input level:	
6.4 Adjacent channel selectivity	0 dB
6.5 Blocking characteristics	0 dB
6.6 Spurious Response	0 dB
6.7 Intermodulation Characteristics	0 dB
6.8 Spurious emissions	0 dB

F.2.3 Performance requirements

Table F.2.3 Test Tolerances for Performance Requirements.

Subclause	Test Tolerance
7.2 Demodulation in Static Propagation Condition	
7.3 Demodulation of DCH in multipath Fading Propagation conditions	
7.4 Demodulation of DCH in Moving Propagation conditions	
7.5 Demodulation of DCH in Birth-Death Propagation conditions	
7.6 Demodulation of DCH in Base Station Transmit diversity	
7.7 Demodulation in Handover conditions	
7.8 Power control in downlink	
7.9 Downlink compressed mode	
7.10 Blind transport format detection	

F.2.4 Requirements for support of RRM

TBD

F.3 Interpretation of measurement results

The measurement results returned by the Test System are compared - without any modification - against the Test Requirements as defined by the shared risk principle.

The Shared Risk principle is defined in ETR 273 Part 1 sub-part 2 section 6.5.

The actual measurement uncertainty of the Test System for the measurement of each parameter shall be included in the test report.

The recorded value for the Test System uncertainty shall be, for each measurement, equal to or lower than the appropriate figure in subclause F.1 of this specification.

If the Test System for a test is known to have a measurement uncertainty greater than that specified in subclause F.1, it is still permitted to use this apparatus provided that an adjustment is made value as follows.

Any additional uncertainty in the Test System over and above that specified in subclause F.1 shall be used to tighten the Test Requirement – making the test harder to pass. (For some tests e.g. receiver tests, this may require modification of stimulus signals). This procedure will ensure that a Test System not compliant with subclause F.1 does not increase the

chance of passing a device under test where that device would otherwise have failed the test if a Test System compliant with subclause F.1 had been used.

F.4 Derivation of Test Requirements (This subclause is informative)

The Test Requirements in this specification have been calculated by relaxing the Minimum Requirements of the core specification using the Test Tolerances defined in subclause F.2. When the Test Tolerance is zero, the Test Requirement will be the same as the Minimum Requirement. When the Test Tolerance is non-zero, the Test Requirements will differ from the Minimum Requirements, and the formula used for this relaxation is given in table F.4.

Table F.4. Derivation of Test Requirements

Test	Minimum Requirement in TS 25.101	Test Tolerance (TT)	Test Requirement in TS 34.121
5.2 Maximum Output Power	Power class 1 (33 dBm) Tolerance = +1/-3 dB Power class 2 (27 dBm) Tolerance = +1/-3 dB Power class 3 (24 dBm) Tolerance = +1/-3 dB Power class 4 (21 dBm) Tolerance = ±2 dB	0.7 dB	Formula: Upper Tolerance limit + TT Lower Tolerance limit – TT For power classes 1-3: Upper Tolerance limit = +1.7 dB Lower Tolerance limit = -3.7 dB For power class 4: Upper Tolerance limit = +2.7 dB Lower Tolerance limit = -2.7 dB
5.3 Frequency Error	The UE modulated carrier frequency shall be accurate to within ±0.1 ppm compared to the carrier frequency received from the Node B.	10 Hz	Formula: modulated carrier frequency error + TT modulated carrier frequency error = ±(0.1 ppm + 10 Hz).
5.4.3 Minimum Output Power	UE minimum transmit power shall be less than –50 dBm	1.0 dB	Formula: UE minimum transmit power + TT UE minimum transmit power = –49 dBm
5.4.4 Out-of-synchronisation handling of output power:	$\frac{DPCCH_E_c}{I_{or}}$ levels AB: -22 dB BD: -28 dB DE: -24 dB EF: -18 dB transmit ON/OFF time 200ms	[0.3] dB for $\frac{DPCCH_E_c}{I_{or}}$ 0 ms for timing measurement	Formulas: Ratio between A and B + TT Ratio between B and D - TT Ratio between D and E - TT Ratio between E and F + TT transmit ON/OFF time + TT timing $\frac{DPCCH_E_c}{I_{or}}$ levels: AB: -22 + [0.3] dB BD: -28 – [0.3] dB DE: -24 – [0.3] dB EF: -18 + [0.3] dB transmit ON/OFF time 200ms timing Uncertainty of OFF power measurement is handled by Transmit OFF power test and uncertainty of ON power measurement is handled by Minimum output power test.
5.5.1 Transmit OFF power	Transmit OFF power shall be less than -56 dBm	1.0 dB	Formula: Transmit OFF power + TT Transmit OFF power = –55dBm.
5.8 Occupied Bandwidth	The occupied channel bandwidth shall be less than 5 MHz based on a chip rate of 3.84 Mcps.	0 kHz	Formula: occupied channel bandwidth: + TT occupied channel bandwidth = 5.0 MHz
5.9 Spectrum emission mask	Minimum requirement defined in TS25.101 Table 6.10. The lower limit shall be –50 dBm / 3.84 MHz or which ever is higher.	1.5 dB	Formula: Minimum requirement + TT Lower limit + TT Add 1.5 to Minimum requirement entries in TS25.101 Table 6.10 The lower limit shall be –48.5 dBm / 3.84 MHz or which ever is higher.

5.10 Adjacent Channel Leakage Power Ratio (ACLR)	Power Classes 3 and 4: UE channel +5 MHz or -5 MHz, ACLR limit: 33 dB UE channel +10 MHz or -10 MHz, ACLR limit: 43 dB	0.8 dB	Formula: ACLR limit - TT Power Classes 3 and 4: UE channel +5 MHz or -5 MHz, ACLR limit: 32.2 dB UE channel +10 MHz or -10 MHz, ACLR limit: 42.2 dB		
5.11 Spurious Emissions			Formula: Minimum Requirement+ TT Add zero to all the values of Minimum Requirements in table 5.11.1a and 5.11.1b.		
	Frequency Band	Minimum Requirement	Frequency Band	Minimum Requirement	
	9 kHz ≤ f < 150 kHz	-36dBm /1kHz	0 dB	9kHz ≤ f < 1GHz	-36dBm /1kHz
	150 kHz ≤ f < 30 MHz	-36dBm /10kHz	0 dB	150 kHz ≤ f < 30 MHz	-36dBm /10kHz
	30 MHz ≤ f < 1000 MHz	-36dBm /100kHz	0 dB	30 MHz ≤ f < 1000 MHz	-36dBm /100kHz
	1 GHz ≤ f < 12.75 GHz	-30dBm /1MHz	0 dB	1 GHz ≤ f < 2.2 GHz	-30dBm /1MHz
			0 dB	2.2 GHz ≤ f < 4 GHz	-30dBm /1MHz
			0 dB	4 GHz ≤ f < 12.75 GHz	-30dBm /1MHz
	1893.5 MHz < f < 1919.6 MHz	-41dBm /300kHz	0 dB	1893.5 MHz < f < 1919.6 MHz	-41dBm /300kHz
	925 MHz ≤ f ≤ 935 MHz	-67dBm /100kHz	0 dB	925 MHz ≤ f ≤ 935 MHz	-67dBm /100kHz
935 MHz < f ≤ 960 MHz	-79dBm /100kHz	0 dB	935 MHz < f ≤ 960 MHz	-79dBm /100kHz	
1805 MHz ≤ f ≤ 1880 MHz	-71dBm /100kHz	0 dB	1805 MHz ≤ f ≤ 1880 MHz	-71dBm /100kHz	
5.12 Transmit Intermodulation	Intermodulation Product 5MHz -31 dBc 10MHz -41 dBc		Formula: Intermodulation Product + TT Intermodulation Product 5MHz -31 + TT dBc 10MHz -41 +TT dBc		
5.13.1 Transmit modulation: EVM	The measured EVM shall not exceed 17.5%.	0%	Formula: EVM limit + TT EVM limit = 17.5 %		
5.13.2 Transmit modulation: peak code domain error	The measured Peak code domain error shall not exceed -15 dB.	1.0 dB	Formula: Peak code domain error + TT Peak code domain error = -14 dB		
6.2 Reference sensitivity level	$\hat{I}_{or} = -106.7 \text{ dBm} / 3.84 \text{ MHz}$ DPCH_Ec = -117 dBm / 3.84 MHz BER limit = 0.001	0.7 dB	Formula: $\hat{I}_{or} + TT$ DPCH_Ec + TT BER limit unchanged $\hat{I}_{or} = -106 \text{ dBm} / 3.84 \text{ MHz}$ DPCH_Ec = -116.3 dBm / 3.84 MHz		

6.4 Adjacent Channel Selectivity	$\hat{I}_{or} = -92.7 \text{ dBm} / 3.84 \text{ MHz}$ $\text{DPCH_Ec} = -103 \text{ dBm} / 3.84 \text{ MHz}$ $\text{Ioac (modulated)} = -52 \text{ dBm} / 3.84 \text{ MHz}$ $\text{BER limit} = 0.001$		0 dB	Formula: \hat{I}_{or} unchanged DPCH_Ec unchanged $\text{Ioac} - \text{TT}$ BER limit unchanged $\text{Ioac} = -52 \text{ dBm} / 3.84 \text{ MHz}$	
6.5 Blocking Characteristics	See Table 6.5.3 and 6.5.4. in TS34.121 $\text{BER limit} = 0.001$		0 dB	Formula: $I_{\text{blocking (modulated)}} - \text{TT}$ (dBm/3.84MHz) $I_{\text{blocking (CW)}} - \text{TT}$ (dBm) BER limit unchanged	
6.6 Spurious Response	$I_{\text{blocking(CW)}} -44 \text{ dBm}$ F_{uw} : Spurious response frequencies $\text{BER limit} = 0.001$		0 dB	Formula: $I_{\text{blocking (CW)}} - \text{TT}$ (dBm) F_{uw} unchanged BER limit unchanged $I_{\text{blocking(CW)}} = -44 \text{ dBm}$	
6.7 Intermodulation Characteristics	$I_{ouw1 (CW)} -46 \text{ dBm}$ $I_{ouw2 (modulated)} -46 \text{ dBm} / 3.84 \text{ MHz}$ $F_{uw1 (offset)} 10 \text{ MHz}$ $F_{uw2 (offset)} 20 \text{ MHz}$ $\text{BER limit} = 0.001$		0 dB	Formula: TBD BER limit unchanged.	
6.8 Spurious Emissions				Formula: Maximum level+ TT Add zero to all the values of Maximum Level in table 6.8.1.	
	Frequency Band	Maximum level		Frequency Band	Maximum level
	$9\text{kHz} \leq f < 1\text{GHz}$	-57dBm /100kHz	0 dB	$9\text{kHz} \leq f < 1\text{GHz}$	-57dBm /100kHz
	$1\text{GHz} \leq f \leq 12.75\text{GHz}$	-47dBm /1MHz	0 dB	$1\text{GHz} \leq f \leq 2.2\text{GHz}$	-47dBm /1MHz
			0 dB	$2.2\text{GHz} < f \leq 4\text{GHz}$	-47dBm /1MHz
			0 dB	$4\text{GHz} < f \leq 12.75\text{GHz}$	-47dBm /1MHz
	$1920\text{MHz} \leq f \leq 1980\text{MHz}$	-60dBm /3.84MHz	0 dB	$1920\text{MHz} \leq f \leq 1980\text{MHz}$	-60dBm /3.84MHz
$2110\text{MHz} \leq f \leq 2170\text{MHz}$	-60dBm /3.84MHz	0 dB	$2110\text{MHz} \leq f \leq 2170\text{MHz}$	-60dBm /3.84MHz	

F.5 Acceptable uncertainty of Test Equipment (This subclause is informative)

This informative subclause specifies the critical parameters of the components of an overall Test System (e.g. Signal generators, Signal Analysers etc.) which are necessary when assembling a Test System that complies with subclause F.1 Acceptable Uncertainty of Test System. These Test Equipment parameters are fundamental to the accuracy of the overall Test System and are unlikely to be improved upon through System Calibration.

F.5.1 Transmitter measurements

Table F.5.1 Equipment accuracy for transmitter measurements

Test	Equipment accuracy	Test conditions
5.2 Maximum Output Power	Not critical	21 to 33 dBm
5.3 Frequency error	± 10 Hz	0 to 500 Hz.
5.4.1 Open loop power control in uplink	Not critical	-43.7 dBm to 21 dBm
5.4.2 Inner loop power control in the uplink – 1 dB	±[0.1] dB relative over a 1.5 dB range	+21 dBm to -50 dBm
5.4.2 Inner loop power control in the uplink – 10 dB	±[0.3] dB relative over a 12 dB range	+21 dBm to -50 dBm
5.4.3 Minimum Output Power	Not critical	
5.4.4 Out-of-synchronisation handling of output power: $\frac{DPCCH_E_c}{I_{or}}$		
5.4.4 Out-of-synchronisation handling of output power: transmit ON/OFF time		
5.5.1 Transmit ON/OFF Power: UE transmit OFF power		
5.5.2 Transmit ON/OFF Power: transmit ON/OFF time mask		
5.6 Change of TFC: power control step size		
5.6 Change of TFC: timing		
5.7 Power setting in uplink compressed mode:-UE output power		
5.8 Occupied Bandwidth	±100 kHz	For results between 4 and 6 MHz?
5.9 Spectrum emission mask	Not critical	P_Max Accuracy applies ±5 dB either side of UE requirements
5.10 ACLR	5 MHz offset ± 0.8 dB 10 MHz offset ± 0.8 dB	P_Max at 5 MHz offset for results between 40 dB and 50 dB. P_Max at 10 MHz offset for results between 45 dB and 55 dB.
5.11 Spurious emissions	Not critical	P_Max
5.12 Transmit Intermodulation	Not critical	P_Max
5.13.1 Transmit modulation: EVM	±2.5 % (for single code)	33 dBm to -20 dBm
5.13.2 Transmit modulation: peak code domain error	±1.0dB	For readings between -10 dB to -20 dB.

F.5.2 Receiver measurements

Table F.5.2: Equipment accuracy for receiver measurements

Subclause	Equipment accuracy	Test conditions
6.2 Reference sensitivity level	Not critical	
6.3 Maximum input level:	Not critical	
6.4 Adjacent channel selectivity	Not critical	
6.5 Blocking characteristics	Not critical	
6.6 Spurious Response	Not critical	
6.7 Intermod Characteristics	Not critical	
6.8 Spurious emissions	Not critical	

F.5.3 Performance measurements

Table G.3: Equipment accuracy for performance measurements

Subclause	Equipment accuracy	Test conditions
7.2 Demodulation in Static Propagation Condition	Not critical	
7.3 Demodulation of DCH in multipath Fading Propagation conditions	Not critical	
7.4 Demodulation of DCH in Moving Propagation conditions	Not critical	
7.5 Demodulation of DCH in Birth-Death Propagation conditions	Not critical	
7.6 Demodulation of DCH in Base Station Transmit diversity	Not critical	
7.7 Demodulation in Handover conditions	Not critical	
7.8 Power control in downlink	Not critical	
7.9 Downlink compressed mode	Not critical	
7.10 Blind transport format detection	Not critical	

F.6 General rules for statistical testing

[TBD]

Annex G (normative): Environmental conditions

G.1 General

This normative annex specifies the environmental requirements of the UE. Within these limits the requirements of this specifications shall be fulfilled.

G.2 Environmental requirements

The requirements in this clause apply to all types of UE(s)

G.2.1 Temperature

The UE shall fulfil all the requirements in the full temperature range of:

Table G.2.1.1

+15°C to +35°C	for normal conditions (with relative humidity of 25 % to 75 %)
-10°C to +55°C	for extreme conditions (see IEC publications 68-2-1 and 68-2-2)

Outside this temperature range the UE, if powered on, shall not make ineffective use of the radio frequency spectrum. In no case shall the UE exceed the transmitted levels as defined in [1] TS 25.101 for extreme operation.

G.2.2 Voltage

The UE shall fulfil all the requirements in the full voltage range, i.e. the voltage range between the extreme voltages.

The manufacturer shall declare the lower and higher extreme voltages and the approximate shutdown voltage. For the equipment that can be operated from one or more of the power sources listed below, the lower extreme voltage shall not be higher, and the higher extreme voltage shall not be lower than that specified below.

Table G.2.2.1

Power source	Lower extreme voltage	Higher extreme voltage	Normal conditions voltage
AC mains	0.9 * nominal	1.1 * nominal	nominal
Regulated lead acid battery	0.9 * nominal	1.3 * nominal	1.1 * nominal
Non regulated batteries: - Leclanché / lithium - Mercury/nickel & cadmium	0.85 * nominal 0.90 * nominal	Nominal Nominal	Nominal Nominal

Outside this voltage range the UE if powered on, shall not make ineffective use of the radio frequency spectrum. In no case shall the UE exceed the transmitted levels as defined in [1] TS 25.101 for extreme operation. In particular, the UE shall inhibit all RF transmissions when the power supply voltage is below the manufacturer declared shutdown voltage.

G.2.3 Vibration

The UE shall fulfil all the requirements when vibrated at the following frequency/amplitudes:

Table G.2.3.1

Frequency	ASD (Acceleration Spectral Density) random vibration
5 Hz to 20 Hz	0.96 m ² /s ³
20 Hz to 500 Hz	0.96 m ² /s ³ at 20 Hz, thereafter -3 dB / Octave

Outside the specified frequency range the UE, if powered on, shall not make ineffective use of the radio frequency spectrum. In no case shall the UE exceed the transmitted levels as defined in [1] TS 25.101 for extreme operation

Annex H (normative): UE Capabilities (FDD)

H.1 Radio Access and RF Baseline Implementation Capabilities:

NOTES:

This clause shall be aligned with TR25.926, UE Radio Access Capabilities regarding FDD RF parameters. These RF UE Radio Access capabilities represent options in the UE, that require signalling to the network.

In addition there are options in the UE that do not require any signalling. They are designated as UE baseline capabilities, according to TR 21.904, Terminal Capability Requirements.

Table H.1 provides the list of UE radio access capability parameters and possible values.

Table H.1: RF UE Radio Access Capabilities

	UE radio access capability parameter	Value range
FDD RF parameters	UE power class ([1] 25.101 subclause 6.2.1)	3, 4
	Tx/Rx frequency separation for frequency band a) ([1] 25.101 subclause 5.3) Not applicable if UE is not operating in frequency band a)	190 MHz, 174.8-205.2 MHz, 134.8-245.2 MHz

Table H.2 provides the UE baseline implementation capabilities.

Table H.2: UE RF Baseline Implementation Capabilities

UE implementation capability	Value range
Radio frequency bands ([1] 25.101 subclause 5.2)	a), b), a+b)

- The special conformance testing functions and the logical test interface as specified in [4] TS 34.109. This issue is currently under investigation.
- Uplink reference measurement channel 12.2 kbps (FDD), [1] TS 25.101 subclause A.2.1
- Downlink reference measurement channel 12.2 kbps (FDD), [1] TS 25.101 subclause A.3.1.

H.2 Service Implementation Capabilities:

- Uplink reference measurement channel 64 kbps (FDD), [1] TS 25.101 subclause A.2.2
- Uplink reference measurement channel 144 kbps (FDD), [1] TS 25.101 subclause A.2.3
- Uplink reference measurement channel 384 kbps (FDD), [1] TS 25.101 subclause A.2.4
- Downlink reference measurement channel 64 kbps (FDD), [1] TS 25.101 subclause A.3.2.
- Downlink reference measurement channel 144 kbps (FDD), [1] TS 25.101 subclause A.3.3.
- Down-link reference measurement channel 384 kbps (FDD), [1] TS 25.101 subclause A.3.4.

Annex I (informative): Test cases requiring evaluation for applicability

I.1 General

This annex contains test cases that were removed from 34.121 V3.2.0 (2000-09), clause 8 when it was restructured according to core requirements in 25.133 V3.3.0 (2000-09). The test cases were left out because no corresponding core requirement existed. This, however, does not mean that there will not be any corresponding core requirements in future versions of 25.133. Therefore, to preserve the content for future enhancements, it has been decided to move these test specifications to this annex.

I.2 Synchronization performance

8.5.1 Synchronization performance

8.5.1.1 Search of other Cells

8.5.1.1.1 Definition and applicability

Search for other cells is used to check whether the UE correctly searches and measures other BS(s) during the specified operation.

<Editor's Note: The applicability for this test whether it is mandatory or not should be clarified.>

8.5.1.1.2 Conformance requirements

[TBD]

Table 8.5.1.1.1: Test Parameters for the Search of other Cells

Parameter	Channel 1		Channel 2		Unit
	Time 1	Time 2	Time 1	Time 2	
$PCCPCH \frac{E_c}{I_{or}}$					dB
\hat{I}_{or}/I_{oc}					dB
I_{oc}	-60				dBm / 3.84 MHz
$PCCPCH \frac{E_c}{I_o}$					dB

The reference for this requirement is [2] TS 25.133 subclause 7.1.1.1.

8.5.1.1.3 Test purpose

[TBD]

8.5.1.1.4 Method of test

The measuring configuration is shown in Figure A.9.

8.5.1.1.4.1 Initial conditions

[TBD]

8.5.1.1.4.2 Procedures

1. Setup the equipment as shown in Figure A.11 (without fading channel blocks).
2. Set the test parameters as specified in Table 8.5.1.1.1.
3. Turn UE on.
4. TBD

8.5.1.1.5 Test requirements

[TBD]

1.3 Reception timing

8.5.4 Reception Timing

8.5.4.1 Definition and applicability

The reception timing of the UE is determined during the specified operation.

<Editor's Note: The applicability for this test whether it is mandatory or not should be clarified.>

8.5.4.2 Conformance requirements

[TBD]

The reference for this requirement is [2] TS 25.133 subclause 7.4.1.

8.5.4.3 Test purpose

[TBD]

8.5.4.4 Method of test

The measuring configuration is shown in Figure A.9.

8.5.4.4.1 Initial conditions

[TBD]

8.5.4.4.2 Procedures

[TBD]

8.5.4.5 Test requirements

[TBD]

Annex J (informative): Information about special regional application of test cases and requirements

This annex provides information about special regional application of the tests specified in the core part of this specification. The special regional application of certain test cases is typically caused by specific local regulation and legalisation.

J.1 Japan

For regulatory testing in Japan shared risk against core specification value with test tolerance of zero may be applied provisionally, until the time the non-zero test tolerances principle used in this specification is reflected in Japanese regulations, The shared risk principle described above will apply to the following requirements:

- 5.2 Maximum output power
- 5.3 Frequency error
- 5.4.1 Open Loop Power Control in the Uplink
- 5.4.2 Inner Loop Power Control in the uplink
- 5.5.1 Transmit off power
- 5.10 Spectrum Emission Mask
- 5.13.2 Peak code domain error
- 6.2 Receiver Sensitivity Level
- 6.4 Adjacent Channel Selectivity
- 6.7 Intermodulation Characteristics

Note: This information should be reviewed on a regular basis to check its applicability, as changes to regulation allowing usage of the non-zero test tolerances principle are expected.

Annex K (informative): Change history

T Meeting	Doc-1st-Level	CR	Rev	Subject	Cat	Version - Current	Version -New	Doc-2nd-Level
TP-07				Approval of the specification		2.0.0	3.0.0	
				No change: replaces invalid zip file on server		3.0.0	3.0.1	
TP-08	TP-000090	001		Editorial corrections to clauses 2, 3, 4 and 5.1	D	3.0.1	3.1.0	T1-000059
TP-08	TP-000090	002		Modifications to clause 5.4 "Output Power Dynamics in the Uplink"	C	3.0.1	3.1.0	T1-000060
TP-08	TP-000090	003		Out-of-synchronisation handling of the UE	B	3.0.1	3.1.0	T1-000061
TP-08	TP-000090	004		Modifications to clauses 5.8, 5.9, 5.10 and 5.11	D	3.0.1	3.1.0	T1-000062
TP-08	TP-000090	005		Modifications to Chapter 6 "Receiver Characteristics"	F	3.0.1	3.1.0	T1-000063
TP-08	TP-000090	006		Modifications to Annex D, Annex E, Annex G and Annex H	F	3.0.1	3.1.0	T1-000067
TP-08	TP-000090	008		Modifications to clauses 5.5, 5.6 and 5.7	F	3.0.1	3.1.0	T1-000069
TP-08	TP-000090	009		Modifications to Chapter 7 "Performance requirements"	F	3.0.1	3.1.0	T1-000070
TP-08	TP-000090	010		Modifications to test power control in downlink	F	3.0.1	3.1.0	T1-000071
TP-08	TP-000090	011		Modifications to clause 5.13 "Transmit Modulation"	F	3.0.1	3.1.0	T1-000072
TP-08	TP-000090	012		Modifications to test for inner loop power control in the uplink	F	3.0.1	3.1.0	T1-000073
TP-08	TP-000090	013		Revision of Annex B: Global in-channel Tx test	F	3.0.1	3.1.0	T1-000074
TP-08	TP-000090	014		Blind transport format detection	B	3.0.1	3.1.0	T1-000075
TP-08	TP-000090	015		Removal of Annex I "Open Items"	D	3.0.1	3.1.0	T1-000077
TP-08	TP-000090	016		Modifications to Chapter 8 "Requirements for support of RRM"	C	3.0.1	3.1.0	T1-000117
TP-08	TP-000090	017		Modifications to Annex C "Measurement channels"	F	3.0.1	3.1.0	T1-000118
TP-08	TP-000090	018		Idle mode test cases (test of performance requirements)	F	3.0.1	3.1.0	T1-000119
TP-09	TP-000163	019		Editorial corrections for References and Frequency Stability (2, 5.2, 5.3)	F	3.1.0	3.2.0	T1-000131
TP-09	TP-000163	020		Corrections for Output Power Dynamics in the Uplink (5.4)	F	3.1.0	3.2.0	T1-000132
TP-09	TP-000163	021		Transients for uplink inner loop power control (5.4.2.4.2)	F	3.1.0	3.2.0	T1-000133
TP-09	TP-000163	022		Transmit On/Off power (5.5.2.4.2)	F	3.1.0	3.2.0	T1-000134
TP-09	TP-000163	023		Change of TFC (5.6.4.2)	F	3.1.0	3.2.0	T1-000135
TP-09	TP-000163	024		Clarification of the definition on Peak Code Domain Error (5.13.2.1)	F	3.1.0	3.2.0	T1-000139
TP-09	TP-000163	025		UE interfering signal definition (6.3, 6.4, 6.5, 6.7)	F	3.1.0	3.2.0	T1-000140
TP-09	TP-000163	026		Performance requirements (7.1, 7.2, 7.3, 7.4, 7.5)	F	3.1.0	3.2.0	T1-000143
TP-09	TP-000163	027		CR on clause 7.6 and 7.7 in TS34.121 (7.6, 7.7)	F	3.1.0	3.2.0	T1-000144
TP-09	TP-000163	028		Performance requirements (7.9, 7.10, 7.11)	F	3.1.0	3.2.0	T1-000146
TP-09	TP-000163	029		Corrections for Annex D (Annex-D)	F	3.1.0	3.2.0	T1-000147
TP-09	TP-000163	030		Corrections for Annex E (Annex-E)	F	3.1.0	3.2.0	T1-000148
TP-09	TP-000163	031		Corrections for Transmit ON/OFF Power, Change of TFC and Power setting in uplink compressed mode (5.5, 5.6, 5.7)	F	3.1.0	3.2.0	T1-000149
TP-09	TP-000163	032		Corrections for power setting in uplink compressed mode (5.7)	F	3.1.0	3.2.0	T1-000136
TP-09	TP-000163	033		CR for subclause 7.8: Power control in downlink (7.8)	B	3.1.0	3.2.0	T1-000145
TP-09	TP-000163	034		Corrections to clause 5.8, 5.9, 5.10, 5.11 and 5.12	F	3.1.0	3.2.0	T1-000137
TP-09	TP-000163	035		Corrections to EVM and PCDE formulae (B.2.7.1, B2.7.2)	F	3.1.0	3.2.0	T1-000138
TP-09	TP-000163	036		New initial conditions for Spurious emission test case (6.8.4.1)	F	3.1.0	3.2.0	T1-000141
TP-09	TP-000163	037		C.4.1 UL reference measurement channel for BTFD performance requirement (C.4.1)	F	3.1.0	3.2.0	T1-000142
TP-10	TP-000216	038		Corrections to Chapter 3 "Definitions, symbols, abbreviations and equations"	D	3.2.0	3.3.0	T1-000247
TP-10	TP-000216	039		Vocabulary Corrections	D	3.2.0	3.3.0	T1-000253
TP-10	TP-000216	040		Reference Measurement Channels in Annex C	F	3.2.0	3.3.0	T1-000238
TP-10	TP-000216	041		Inclusion of OCNS definition for performance tests	F	3.2.0	3.3.0	T1-000241
TP-10	TP-000216	042		Handling of measurement uncertainties in UE conformance testing (FDD)	F	3.2.0	3.3.0	T1-000250
TP-10	TP-000216	043		Update of Idle mode test cases	F	3.2.0	3.3.0	T1-000252
TP-10	TP-000216	044		UE emission mask measurement filter definition correction	F	3.2.0	3.3.0	T1-000254
TP-10	TP-000216	045		New structure of TS 34.121	F	3.2.0	3.3.0	T1-000255
TP-10	TP-000216	046		Test for combining TPC commands in soft handover	F	3.2.0	3.3.0	T1-000239
TP-10	TP-000216	047		Corrections to power control tests	F	3.2.0	3.3.0	T1-000240
TP-10	TP-000216	048		Correction to Open Loop Power Control in Uplink	F	3.2.0	3.3.0	T1-000242
TP-10	TP-000216	049		Correction to Transmit ON/OFF Time mask	F	3.2.0	3.3.0	T1-000243r
TP-10	TP-000216	050		Correction to Spurious Emission test	F	3.2.0	3.3.0	T1-000244

T Meeting	Doc-1st-Level	CR	Rev	Subject	Cat	Version - Current	Version -New	Doc-2nd-Level
TP-10	TP-000216	051		Correction of spurious emission measurement procedure	F	3.2.0	3.3.0	T1-000245
TP-10	TP-000216	052		Out-of-synchronization handling of output power	F	3.2.0	3.3.0	T1-000246
TP-10	TP-000216	053		Clarification of test procedure and test requirement for receiver blocking and spurious response.	F	3.2.0	3.3.0	T1-000248
TP-10	TP-000216	054		Subclause 7.8 Power control in downlink	F	3.2.0	3.3.0	T1-000249
TP-10	TP-000216	055		Downlink compressed mode	F	3.2.0	3.3.0	T1-000251
TP-11	TP-010019	056		CR on Test tolerance for 6.5 Blocking Characteristics	F	3.3.0	3.4.0	T1-010020
TP-11	TP-010019	057		CR on Test tolerance for 6.7 Intermodulation Characteristics	F	3.3.0	3.4.0	T1-010025
TP-11	TP-010019	058		CR on Test tolerance for 5.5.1 Test Tolerance for Transmit OFF power	F	3.3.0	3.4.0	T1-010027
TP-11	TP-010019	059		CR on Test tolerance for 6.6 Spurious Response	F	3.3.0	3.4.0	T1-010028
TP-11	TP-010019	060		CR on Test tolerance for 5.11 Test Tolerance for Transmit Spurious emissions	F	3.3.0	3.4.0	T1-010029
TP-11	TP-010019	061		CR on Test tolerance for Annex.F TS34.121	F	3.3.0	3.4.0	T1-010030
TP-11	TP-010019	062		CR on Test tolerance for 5.2 Maximum output power	F	3.3.0	3.4.0	T1-010031
TP-11	TP-010019	063		CR on Test tolerance for 5.4.3 Minimum Output Power	F	3.3.0	3.4.0	T1-010032
TP-11	TP-010019	064		CR on Test tolerance for 5.9 Spectrum Emission Mask	F	3.3.0	3.4.0	T1-010033
TP-11	TP-010019	065		CR on Test tolerance for 5.10 ACLR	F	3.3.0	3.4.0	T1-010034
TP-11	TP-010019	066		CR on Test tolerance for 5.12 Transmit Intermodulation	F	3.3.0	3.4.0	T1-010035
TP-11	TP-010019	067		CR on Test tolerance for 6.2 Reference Sensitivity Level	F	3.3.0	3.4.0	T1-010036
TP-11	TP-010019	068		CR on Test tolerance for 5.3 Frequency Error	F	3.3.0	3.4.0	T1-010037
TP-11	TP-010019	069		CR on Test tolerance for 5.8 Occupied Bandwidth	F	3.3.0	3.4.0	T1-010038
TP-11	TP-010019	070		CR on Test tolerance for 5.13.1 EVM	F	3.3.0	3.4.0	T1-010039
TP-11	TP-010019	071		CR on Test tolerance for 5.13.2 PCDE	F	3.3.0	3.4.0	T1-010040
TP-11	TP-010019	072		CR on Test tolerance for 5.4.4 Out of Synchronisation transmit power	F	3.3.0	3.4.0	T1-010041
TP-11	TP-010019	073		CR on Test tolerance for 6.4 ACS	F	3.3.0	3.4.0	T1-010042
TP-11	TP-010019	074		CR on Test tolerance for 6.8 RX Spurious Emissions	F	3.3.0	3.4.0	T1-010108
TP-11	TP-010019	075		CR on corrections to DL compressed mode	F	3.3.0	3.4.0	T1-010021
TP-11	TP-010019	076		CR on Corrections to DL 384kbps and BTFD measurement channels	F	3.3.0	3.4.0	T1-010022
TP-11	TP-010019	077		CR on Corrections to Maximum output power	F	3.3.0	3.4.0	T1-010023
TP-11	TP-010019	078		CR on RX spurious emissions	F	3.3.0	3.4.0	T1-010024
TP-11	TP-010019	079		CR on Editorial correction to channel number	D	3.3.0	3.4.0	T1-010026
TP-11	TP-010019	080		CR Correction of Annex-E and reference information to Annex E	F	3.3.0	3.4.0	T1-010043
TP-11	TP-010019	081		Editorial corrections	D	3.3.0	3.4.0	T1-010044
TP-11	TP-010076	082	1	Regional requirements on Test Tolerance	F	3.3.0	3.4.0	Presented directly to TP-11

History

Document history		
V3.0.0	March 2000	Publication
V3.1.0	June 2000	Publication
V3.2.0	September 2000	Publication
V3.3.0	December 2000	Publication
V3.4.0	March 2001	Publication