

ETSI TS 134 121 V3.12.0 (2003-03)

Technical Specification

**Universal Mobile Telecommunications System (UMTS);
Terminal conformance specification;
Radio Transmission and Reception (FDD)
(3GPP TS 34.121 version 3.12.0 Release 1999)**



Reference

RTS/TSGT-0134121v3c0

Keywords

UMTS

ETSI

650 Route des Lucioles
F-06921 Sophia Antipolis Cedex - FRANCE

Tel.: +33 4 92 94 42 00 Fax: +33 4 93 65 47 16

Siret N° 348 623 562 00017 - NAF 742 C
Association à but non lucratif enregistrée à la
Sous-Préfecture de Grasse (06) N° 7803/88

Important notice

Individual copies of the present document can be downloaded from:

<http://www.etsi.org>

The present document may be made available in more than one electronic version or in print. In any case of existing or perceived difference in contents between such versions, the reference version is the Portable Document Format (PDF). In case of dispute, the reference shall be the printing on ETSI printers of the PDF version kept on a specific network drive within ETSI Secretariat.

Users of the present document should be aware that the document may be subject to revision or change of status. Information on the current status of this and other ETSI documents is available at

<http://portal.etsi.org/tb/status/status.asp>

If you find errors in the present document, send your comment to:

editor@etsi.org

Copyright Notification

No part may be reproduced except as authorized by written permission.
The copyright and the foregoing restriction extend to reproduction in all media.

© European Telecommunications Standards Institute 2003.
All rights reserved.

DECTTM, **PLUGTESTS**TM and **UMTS**TM are Trade Marks of ETSI registered for the benefit of its Members.
TIPHONTM and the **TIPHON logo** are Trade Marks currently being registered by ETSI for the benefit of its Members.
3GPPTM is a Trade Mark of ETSI registered for the benefit of its Members and of the 3GPP Organizational Partners.

Intellectual Property Rights

IPRs essential or potentially essential to the present document may have been declared to ETSI. The information pertaining to these essential IPRs, if any, is publicly available for **ETSI members and non-members**, and can be found in ETSI SR 000 314: *"Intellectual Property Rights (IPRs); Essential, or potentially Essential, IPRs notified to ETSI in respect of ETSI standards"*, which is available from the ETSI Secretariat. Latest updates are available on the ETSI Web server (<http://webapp.etsi.org/IPR/home.asp>).

All published ETSI deliverables shall include information which directs the reader to the above source of information.

Foreword

This Technical Specification (TS) has been produced by ETSI 3rd Generation Partnership Project (3GPP).

The present document may refer to technical specifications or reports using their 3GPP identities, UMTS identities or GSM identities. These should be interpreted as being references to the corresponding ETSI deliverables.

The cross reference between GSM, UMTS, 3GPP and ETSI identities can be found under <http://webapp.etsi.org/key/queryform.asp>.

Contents

Intellectual Property Rights	2
Foreword.....	2
Foreword.....	15
1 Scope	16
2 References	16
3 Definitions, symbols, abbreviations and equations	17
3.1 Definitions	17
3.2 Symbols.....	17
3.3 Abbreviations	17
3.4 Equations.....	18
4 Frequency bands and channel arrangement.....	19
4.1 General	19
4.2 Frequency bands.....	19
4.3 TX–RX frequency separation.....	20
4.4 Channel arrangement.....	20
4.4.1 Channel spacing.....	20
4.4.2 Channel raster	20
4.4.3 Channel number.....	20
4.4.4 UARFCN.....	20
5 Transmitter Characteristics.....	21
5.1 General	21
5.2 Maximum Output Power.....	21
5.2.1 Definition and applicability	21
5.2.2 Minimum Requirements	22
5.2.3 Test purpose.....	22
5.2.4 Method of test.....	22
5.2.4.1 Initial conditions	22
5.2.4.2 Procedure	22
5.2.5 Test requirements.....	22
5.3 Frequency Error.....	23
5.3.1 Definition and applicability	23
5.3.2 Minimum Requirements	23
5.3.3 Test purpose.....	23
5.3.4 Method of test.....	23
5.3.5 Test Requirements	24
5.4 Output Power Dynamics in the Uplink.....	24
5.4.1 Open Loop Power Control in the Uplink	24
5.4.1.1 Definition and applicability.....	24
5.4.1.2 Minimum requirements.....	24
5.4.1.3 Test purpose	24
5.4.1.4 Method of test	25
5.4.1.5 Test requirements.....	25
5.4.2 Inner Loop Power Control in the Uplink	26
5.4.2.1 Definition and applicability.....	26
5.4.2.2 Minimum requirements	26
5.4.2.3 Test purpose	27
5.4.2.4 Method of test	27
5.4.2.5 Test requirements.....	31
5.4.3 Minimum Output Power	32
5.4.3.1 Definition and applicability.....	32
5.4.3.2 Minimum Requirements.....	33
5.4.3.3 Test purpose	33
5.4.3.4 Method of test	33

5.4.3.5	Test requirements	33
5.4.4	Out-of-synchronisation handling of output power	33
5.4.4.1	Definition and applicability	33
5.4.4.2	Minimum Requirements	34
5.4.4.3	Test purpose	35
5.4.4.4	Method of test	35
5.4.4.5	Test requirements	36
5.5	Transmit ON/OFF Power	37
5.5.1	Transmit OFF Power	37
5.5.1.1	Definition and applicability	37
5.5.1.2	Minimum Requirements	37
5.5.1.3	Test purpose	37
5.5.1.4	Method of test	37
5.5.1.5	Test requirements	37
5.5.2	Transmit ON/OFF Time mask	37
5.5.2.1	Definition and applicability	37
5.5.2.2	Minimum requirements	37
5.5.2.3	Test purpose	39
5.5.2.4	Method of test	39
5.5.2.5	Test requirements	40
5.6	Change of TFC	40
5.6.1	Definition and applicability	40
5.6.2	Minimum requirements	41
5.6.3	Test purpose	42
5.6.4	Method of test	42
5.6.5	Test requirements	42
5.7	Power setting in uplink compressed mode	43
5.7.1	Definition and applicability	43
5.7.2	Minimum requirements	43
5.7.3	Test purpose	44
5.7.4	Method of test	45
5.7.5	Test requirements	52
5.8	Occupied Bandwidth (OBW)	53
5.8.1	Definition and applicability	53
5.8.2	Minimum Requirements	53
5.8.3	Test purpose	54
5.8.4	Method of test	54
5.8.5	Test Requirements	54
5.9	Spectrum emission mask	54
5.9.1	Definition and applicability	54
5.9.2	Minimum Requirements	55
5.9.3	Test purpose	55
5.9.4	Method of test	55
5.9.4.1	Initial conditions	55
5.9.4.2	Procedure	55
5.9.5	Test requirements	56
5.10	Adjacent Channel Leakage Power Ratio (ACLR)	56
5.10.1	Definition and applicability	56
5.10.2	Minimum Requirements	57
5.10.3	Test purpose	57
5.10.4	Method of test	57
5.10.5	Test requirements	58
5.11	Spurious Emissions	58
5.11.1	Definition and applicability	58
5.11.2	Minimum Requirements	58
5.11.3	Test purpose	59
5.11.4	Method of test	59
5.11.5	Test requirements	60
5.12	Transmit Intermodulation	60
5.12.1	Definition and applicability	60
5.12.2	Minimum Requirements	61
5.12.3	Test purpose	61

5.12.4	Method of test	61
5.12.5	Test requirements.....	61
5.13	Transmit Modulation.....	62
5.13.1	Error Vector Magnitude (EVM)	62
5.13.1.1	Definition and applicability.....	62
5.13.1.2	Minimum Requirements.....	62
5.13.1.3	Test purpose	62
5.13.1.4	Method of test	62
5.13.1.5	Test requirements.....	63
5.13.2	Peak code domain error	63
5.13.2.1	Definition and applicability.....	63
5.13.2.2	Minimum Requirements.....	63
5.13.2.3	Test purpose	63
5.13.2.4	Method of test	64
5.13.2.5	Test requirements.....	64
6	Receiver Characteristics	65
6.1	General	65
6.2	Reference Sensitivity Level.....	65
6.2.1	Definition and applicability	65
6.2.2	Minimum Requirements	66
6.2.3	Test purpose.....	66
6.2.4	Method of test.....	66
6.2.5	Test requirements.....	66
6.3	Maximum Input Level.....	67
6.3.1	Definition and applicability	67
6.3.2	Minimum requirements.....	67
6.3.3	Test purpose.....	67
6.3.4	Method of test.....	67
6.3.5	Test requirements.....	68
6.4	Adjacent Channel Selectivity (ACS).....	68
6.4.1	Definition and applicability	68
6.4.2	Minimum Requirements	68
6.4.3	Test purpose.....	69
6.4.4	Method of test.....	69
6.4.5	Test requirements.....	69
6.5	Blocking Characteristics.....	70
6.5.1	Definition and applicability	70
6.5.2	Minimum Requirements	70
6.5.2.1	Minimum Requirements (In-band blocking).....	70
6.5.2.2	Minimum requirements (Out of-band blocking).....	70
6.5.2.3	Minimum requirements (Narrow band blocking).....	71
6.5.3	Test purpose.....	71
6.5.4	Method of test.....	72
6.5.5	Test requirements.....	72
6.6	Spurious Response	73
6.6.1	Definition and applicability	73
6.6.2	Minimum Requirements	74
6.6.3	Test purpose.....	74
6.6.4	Method of test.....	74
6.6.5	Test requirements.....	75
6.7	Intermodulation Characteristics.....	75
6.7.1	Definition and applicability	75
6.7.2	Minimum Requirements	75
6.7.3	Test purpose.....	76
6.7.4	Method of test.....	76
6.7.5	Test requirements.....	77
6.8	Spurious Emissions	77
6.8.1	Definition and applicability	77
6.8.2	Minimum Requirements	77
6.8.3	Test purpose.....	78
6.8.4	Method of test.....	78

6.8.5	Test requirements.....	79
7	Performance requirements.....	79
7.1	General	79
7.1.1	Measurement Configurations.....	80
7.1.2	Definition of Additive White Gaussian Noise (AWGN) Interferer	80
7.2	Demodulation in Static Propagation conditions	80
7.2.1	Demodulation of Dedicated Channel (DCH).....	80
7.2.1.1	Definition and applicability.....	80
7.2.1.2	Minimum requirements	81
7.2.1.3	Test purpose	81
7.2.1.4	Method of test	81
7.2.1.5	Test requirements	82
7.3	Demodulation of DCH in Multi-path Fading Propagation conditions.....	82
7.3.1	Single Link Performance	82
7.3.1.1	Definition and applicability.....	82
7.3.1.2	Minimum requirements	82
7.3.1.3	Test purpose	85
7.3.1.4	Method of test	85
7.3.1.5	Test requirements	85
7.4	Demodulation of DCH in Moving Propagation conditions	88
7.4.1	Single Link Performance	88
7.4.1.1	Definition and applicability.....	88
7.4.1.2	Minimum requirements	88
7.4.1.3	Test purpose	89
7.4.1.4	Method of test	89
7.4.1.5	Test requirements	89
7.5	Demodulation of DCH in Birth-Death Propagation conditions.....	90
7.5.1	Single Link Performance	90
7.5.1.1	Definition and applicability.....	90
7.5.1.2	Minimum requirements	90
7.5.1.3	Test purpose	90
7.5.1.4	Method of test	91
7.5.1.5	Test requirements	91
7.6	Demodulation of DCH in downlink Transmit diversity modes.....	91
7.6.1	Demodulation of DCH in open-loop transmit diversity mode.....	91
7.6.1.1	Definition and applicability.....	91
7.6.1.2	Minimum requirements	92
7.6.1.3	Test purpose	92
7.6.1.4	Method of test	92
7.6.1.5	Test Requirements.....	93
7.6.2	Demodulation of DCH in closed loop transmit diversity mode.....	93
7.6.2.1	Definition and applicability.....	93
7.6.2.2	Minimum requirements	93
7.6.2.3	Test purpose	94
7.6.2.4	Method of test	94
7.6.2.5	Test Requirements.....	94
7.6.3	Demodulation of DCH in Site Selection Diversity Transmission Power Control mode.....	95
7.6.3.1	Definition and applicability.....	95
7.6.3.2	Minimum requirements	95
7.6.3.3	Test purpose	96
7.6.3.4	Method of test	96
7.6.3.5	Test Requirements.....	96
7.7	Demodulation in Handover conditions.....	97
7.7.1	Demodulation of DCH in Inter-Cell Soft Handover	97
7.7.1.1	Definition and applicability.....	97
7.7.1.2	Minimum requirements	97
7.7.1.3	Test purpose	98
7.7.1.4	Method of test	98
7.7.1.5	Test requirements	98
7.7.2	Combining of TPC commands from radio links of different radio link sets.....	99
7.7.2.1	Definition and applicability.....	99

7.7.2.2	Minimum requirements	99
7.7.2.3	Test purpose	100
7.7.2.4	Method of test	100
7.7.2.5	Test requirements	101
7.8	Power control in downlink	102
7.8.1	Power control in the downlink, constant BLER target	102
7.8.1.1	Definition and applicability	102
7.8.1.2	Minimum requirements	103
7.8.1.3	Test purpose	103
7.8.1.4	Method of test	103
7.8.1.5	Test Requirements	104
7.8.2	Power control in the downlink, initial convergence	104
7.8.2.1	Definition and applicability	104
7.8.2.2	Minimum requirements	105
7.8.2.3	Test purpose	105
7.8.2.4	Method of test	105
7.8.2.5	Test Requirements	106
7.8.3	Power control in the downlink, wind up effects	107
7.8.3.1	Definition and applicability	107
7.8.3.2	Minimum requirements	107
7.8.3.3	Test purpose	107
7.8.3.4	Method of test	108
7.8.3.5	Test Requirements	108
7.9	Downlink compressed mode	109
7.9.1	Single link performance	109
7.9.1.1	Definition and applicability	109
7.9.1.2	Minimum requirements	109
7.9.1.3	Test purpose	110
7.9.1.4	Method of test	110
7.9.1.5	Test requirements	110
7.10	Blind transport format detection	111
7.10.1	Definition and applicability	111
7.10.2	Minimum requirements	112
7.10.3	Test purpose	112
7.10.4	Method of test	112
7.10.5	Test requirements	113
8	Requirements for support of RRM	114
8.1	General	114
8.2	Idle Mode Tasks	114
8.2.1	Cell Selection	114
8.2.2	Cell Re-Selection	114
8.2.2.1	Scenario 1: Single carrier case	114
8.2.2.1.1	Definition and applicability	114
8.2.2.1.2	Minimum requirement	114
8.2.2.1.3	Test purpose	114
8.2.2.1.4	Method of test	114
8.2.2.1.5	Test requirements	117
8.2.2.2	Scenario 2: Multi carrier case	117
8.2.2.2.1	Definition and applicability	117
8.2.2.2.2	Minimum requirement	117
8.2.2.2.3	Test purpose	118
8.2.2.2.4	Method of test	118
8.2.2.2.5	Test requirements	120
8.2.3	UTRAN to GSM Cell Re-Selection	121
8.2.3.1	Scenario 1: Both UTRA and GSM level changed	121
8.2.3.1.1	Definition and applicability	121
8.2.3.1.2	Minimum requirement	121
8.2.3.1.3	Test purpose	122
8.2.3.1.4	Method of test	122
8.2.3.1.5	Test requirements	123
8.2.3.2	Scenario 2: Only UTRA level changed	124

8.2.3.2.1	Definition and applicability	124
8.2.3.2.2	Minimum requirement	124
8.2.3.2.3	Test purpose	125
8.2.3.2.4	Method of test.....	125
8.2.3.2.5	Test requirements	126
8.2.4	FDD/TDD Cell Re-selection.....	127
8.2.4.1	Definition and applicability.....	127
8.2.4.2	Minimum requirement	127
8.2.4.3	Test purpose	127
8.2.4.4	Method of test	127
8.2.4.5	Test requirements	129
8.3	UTRAN Connected Mode Mobility	130
8.3.1	FDD/FDD Soft Handover	130
8.3.1.1	Definition and applicability.....	130
8.3.1.2	Minimum requirement	130
8.3.1.3	Test purpose	130
8.3.1.4	Method of test	130
8.3.1.5	Test requirements	135
8.3.2	FDD/FDD Hard Handover.....	135
8.3.2.1	FDD/FDD Hard Handover to intra-frequency cell.....	135
8.3.2.1.1	Definition and applicability	135
8.3.2.1.2	Minimum requirement	135
8.3.2.1.3	Test purpose	136
8.3.2.1.4	Method of test.....	136
8.3.2.1.5	Test requirements	142
8.3.2.2	FDD/FDD Hard Handover to inter-frequency cell.....	142
8.3.2.2.1	Definition and applicability	142
8.3.2.2.2	Minimum requirement.....	142
8.3.2.2.3	Test purpose	143
8.3.2.2.4	Method of test.....	143
8.3.2.2.5	Test requirements	148
8.3.3	FDD/TDD Handover	148
8.3.3.1	Definition and applicability.....	148
8.3.3.2	Minimum requirement	148
8.3.3.3	Test purpose	149
8.3.3.4	Method of test	149
8.3.3.5	Test requirements.....	155
8.3.4	Inter-system Handover from UTRAN FDD to GSM.....	156
8.3.4.1	Definition and applicability	156
8.3.4.2	Minimum requirement.....	156
8.3.4.3	Test purpose	156
8.3.4.4	Method of test.....	156
8.3.4.5	Test requirements	160
8.3.5	Cell Re-selection in CELL_FACH	160
8.3.5.1	One frequency present in neighbour list.....	160
8.3.5.1.1	Definition and applicability	160
8.3.5.1.2	Minimum requirements	160
8.3.5.1.3	Test purpose	161
8.3.5.1.4	Method of test.....	161
8.3.5.1.5	Test requirements	163
8.3.5.2	Two frequencies present in the neighbour list.....	163
8.3.5.2.1	Definition and applicability	163
8.3.5.2.2	Minimum requirements	163
8.3.5.2.3	Test purpose	164
8.3.5.2.4	Method of test.....	164
8.3.5.2.5	Test requirements	167
8.3.5.3	Cell Reselection to GSM.....	168
8.3.6	Cell Re-selection in CELL_PCH	168
8.3.6.1	One frequency present in the neighbour list.....	168
8.3.6.1.1	Definition and applicability	168
8.3.6.1.2	Minimum requirements	169
8.3.6.1.3	Test purpose	169

8.3.6.1.4	Method of test.....	169
8.3.6.1.5	Test requirements	171
8.3.6.2	Two frequencies present in the neighbour list.....	171
8.3.6.2.1	Definition and applicability	171
8.3.6.2.2	Minimum requirement.....	171
8.3.6.2.3	Test purpose	172
8.3.6.2.4	Method of test.....	172
8.3.6.2.5	Test requirements	174
8.3.7	Cell Re-selection in URA_PCH.....	175
8.3.7.1	One frequency present in the neighbour list.....	175
8.3.7.1.1	Definition and applicability	175
8.3.7.1.2	Minimum requirement.....	175
8.3.7.1.3	Test purpose	176
8.3.7.1.4	Method of test.....	176
8.3.7.1.5	Test requirements	178
8.3.7.2	Two frequencies present in the neighbour list.....	178
8.3.7.2.1	Definition and applicability	178
8.3.7.2.2	Minimum requirement.....	178
8.3.7.2.3	Test purpose	179
8.3.7.2.4	Method of test.....	179
8.3.7.2.5	Test requirements	181
8.4	RRC Connection Control	182
8.4.1	RRC Re-establishment delay	182
8.4.1.1	Test 1.....	182
8.4.1.1.1	Definition and applicability	182
8.4.1.1.2	Minimum requirement.....	183
8.4.1.1.3	Test purpose	183
8.4.1.1.4	Method of test.....	183
8.4.1.1.5	Test requirements	185
8.4.1.2	Test 2.....	185
8.4.1.2.1	Definition and applicability	185
8.4.1.2.2	Minimum requirement.....	185
8.4.1.2.3	Test purpose	186
8.4.1.2.4	Method of test.....	186
8.4.1.2.5	Test requirements	187
8.4.2	Random Access	187
8.4.2.1	Correct behaviour when receiving an ACK	187
8.4.2.1.1	Definition and applicability	187
8.4.2.1.2	Minimum Requirements	187
8.4.2.1.3	Test purpose	188
8.4.2.1.4	Method of test.....	188
8.4.2.1.5	Test requirements	189
8.4.2.2	Correct behaviour when receiving an NACK	190
8.4.2.2.1	Definition and applicability	190
8.4.2.2.2	Minimum Requirements	190
8.4.2.2.3	Test purpose	190
8.4.2.2.4	Method of test.....	190
8.4.2.2.5	Test requirements	190
8.4.2.3	Correct behaviour at Time-out	191
8.4.2.3.1	Definition and applicability	191
8.4.2.3.2	Minimum Requirements	191
8.4.2.3.3	Test purpose	191
8.4.2.3.4	Method of test.....	191
8.4.2.3.5	Test requirements	192
8.4.2.4	Correct behaviour when reaching maximum transmit power	192
8.4.2.4.1	Definition and applicability	192
8.4.2.4.2	Minimum Requirements	192
8.4.2.4.3	Test purpose	193
8.4.2.4.4	Method of test.....	193
8.4.2.4.5	Test requirements	193
8.4.3	Transport format combination selection in UE.....	193
8.4.3.1	Interactive or Background, PS, UL: 64 kbps.....	193

8.4.3.1.1	Definition and applicability	193
8.4.3.1.2	Minimum requirements	193
8.4.3.1.3	Test purpose	195
8.4.3.1.4	Method of test.....	195
8.4.3.1.5	Test requirements	196
8.5	Timing and Signalling Characteristics	196
8.5.1	UE Transmit Timing.....	196
8.5.1.1	Definition and applicability.....	196
8.5.1.2	Minimum requirements	196
8.5.1.3	Test purpose	197
8.5.1.4	Method of test	197
8.5.1.5	Test requirements	198
8.6	UE Measurements Procedures.....	199
8.6.1	FDD intra frequency measurements	199
8.6.1.1	Event triggered reporting in AWGN propagation conditions	199
8.6.1.1.1	Definition and applicability	199
8.6.1.1.2	Minimum requirements	199
8.6.1.1.3	Test purpose	200
8.6.1.1.4	Method of test.....	200
8.6.1.1.5	Test requirements	203
8.6.1.2	Event triggered reporting of multiple neighbours in AWGN propagation condition	203
8.6.1.2.1	Definition and applicability	203
8.6.1.2.2	Minimum requirements	203
8.6.1.2.3	Test purpose	203
8.6.1.2.4	Method of test.....	203
8.6.1.2.5	Test requirements	208
8.6.1.3	Event triggered reporting of two detectable neighbours in AWGN propagation condition	208
8.6.1.3.1	Definition and applicability	208
8.6.1.3.2	Minimum requirements	208
8.6.1.3.3	Test purpose	208
8.6.1.3.4	Method of test.....	209
8.6.1.3.5	Test requirements	212
8.6.1.4	Correct reporting of neighbours in fading propagation condition	212
8.6.1.4.1	Definition and applicability	212
8.6.1.4.2	Minimum requirements	212
8.6.1.4.3	Test purpose	212
8.6.1.4.4	Method of test.....	212
8.6.1.4.5	Test requirements	216
8.6.2	FDD inter frequency measurements	216
8.6.2.1	Correct reporting of neighbours in AWGN propagation condition	216
8.6.2.1.1	Definition and applicability	216
8.6.2.1.2	Minimum requirements	216
8.6.2.1.3	Test purpose	217
8.6.2.1.4	Method of test.....	217
8.6.2.1.5	Test requirements	225
8.6.3	TDD measurements	225
8.6.3.1	Correct reporting of TDD neighbours in AWGN propagation condition.....	225
8.6.3.1.1	Definition and applicability	225
8.6.3.1.2	Minimum requirement.....	225
8.6.3.1.3	Test purpose	226
8.6.3.1.4	Method of test.....	226
8.6.3.1.5	Test requirements	232
8.6.4	GSM measurements.....	233
8.6.4.1	Correct reporting of GSM neighbours in AWGN propagation condition	233
8.7	Measurements Performance Requirements	233
8.7.1	CPICH RSCP.....	233
8.7.1.1	Intra frequency measurements accuracy	233
8.7.1.1.1	Absolute accuracy requirement	233
8.7.1.1.2	Relative accuracy requirement	236
8.7.1.2	Inter frequency measurement accuracy.....	237
8.7.1.2.1	Relative accuracy requirement	237
8.7.2	CPICH Ec/Io.....	244

8.7.2.1	Intra frequency measurements accuracy	244
8.7.2.1.1	Absolute accuracy requirement	244
8.7.2.1.2	Relative accuracy requirement	247
8.7.2.2	Inter frequency measurement accuracy	249
8.7.2.2.1	Void	249
8.7.2.2.2	Relative accuracy requirement	249
8.7.3	UTRA Carrier RSSI	255
8.7.3.1	Absolute measurement accuracy requirement	255
8.7.3.1.1	Definition and applicability	255
8.7.3.1.2	Minimum Requirements	255
8.7.3.1.3	Test purpose	255
8.7.3.1.4	Method of test	255
8.7.3.1.5	Test requirements	259
8.7.3.2	Relative measurement accuracy requirement	260
8.7.3.2.1	Definition and applicability	260
8.7.3.2.2	Minimum Requirements	260
8.7.3.2.3	Test purpose	260
8.7.3.2.4	Method of test	260
8.7.3.2.5	Test requirements	261
8.7.3A	GSM Carrier RSSI	262
8.7.3B	Transport channel BLER	262
8.7.3C	UE transmitted power	262
8.7.3C.1	Definition and applicability	262
8.7.3C.2	Minimum requirements	262
8.7.3C.3	Test purpose	262
8.7.3C.4	Method of test	262
8.7.3C.4.1	Initial conditions	262
8.7.3C.4.2	Procedure	263
8.7.3C.5	Test requirements	266
8.7.4	SFN-CFN observed time difference	266
8.7.4.1	Intra frequency measurement requirement	266
8.7.4.1.1	Definition and applicability	266
8.7.4.1.2	Minimum requirements	266
8.7.4.1.3	Test Purpose	267
8.7.4.1.4	Method of test	267
8.7.4.1.5	Test requirements	269
8.7.4.2	Inter frequency measurement requirement	270
8.7.4.2.1	Definition and applicability	270
8.7.4.2.2	Minimum requirements	270
8.7.4.2.3	Test purpose	270
8.7.4.2.4	Method of test	270
8.7.4.2.5	Test requirements	274
8.7.5	SFN-SFN observed time difference	275
8.7.5.1	SFN-SFN observed time difference type 1	275
8.7.5.1.1	Definition and applicability	275
8.7.5.1.2	Minimum requirements	275
8.7.5.1.3	Test purpose	275
8.7.5.1.4	Method of test	275
8.7.5.1.5	Test requirements	277
8.7.5.2	SFN-SFN observed time difference type 2	278
8.7.6	UE Rx-Tx time difference	278
8.7.6.1	UE Rx-Tx time difference type 1	278
8.7.6.1.1	Definition and applicability	278
8.7.6.1.2	Minimum requirements	278
8.7.6.1.3	Test purpose	278
8.7.6.1.4	Method of test	278
8.7.6.1.5	Test requirements	281
8.7.6.2	UE Rx-Tx time difference type 2	282
8.7.7	Observed time difference to GSM cell	282
8.7.8	P-CCPCH RSCP	282
8.7.8.1	Absolute measurement accuracy	282
8.7.8.1.1	Definition and applicability	282

8.7.8.1.2	Minimum Requirements	282
8.7.8.1.3	Test purpose	282
8.7.8.1.4	Method of test.....	282
8.7.8.1.4.1	Initial conditions	282
8.7.8.1.4.2	Procedure	283
8.7.8.1.5	Test requirements	286
Annex A (informative): Connection Diagrams		287
Annex B (normative): Global In-Channel TX-Test.....		296
B.1	General	296
B.2	Definition of the process	296
B.2.1	Basic principle.....	296
B.2.2	Output signal of the TX under test	296
B.2.3	Reference signal	296
B.2.4	Void.....	297
B.2.5	Classification of measurement results	297
B.2.6	Process definition to achieve results of type "deviation".....	297
B.2.6.1	Decision Point Power.....	298
B.2.6.2	Code-Domain Power.....	298
B.2.7	Process definition to achieve results of type "residual"	298
B.2.7.1	Error Vector Magnitude (EVM)	299
B.2.7.2	Peak Code Domain Error (PCDE)	299
B.3	Notes.....	299
Annex C (normative): Measurement channels		303
C.1	General	303
C.2	UL reference measurement channel	303
C.2.1	UL reference measurement channel (12,2 kbps).....	303
C.2.2	UL reference measurement channel (64 kbps).....	306
C.2.3	UL reference measurement channel (144 kbps).....	309
C.2.4	UL reference measurement channel (384 kbps).....	311
C.2.5	UL reference measurement channel (768 kbps).....	313
C.3	DL reference measurement channel	315
C.3.1	DL reference measurement channel (12,2 kbps).....	315
C.3.2	DL reference measurement channel (64 kbps).....	317
C.3.3	DL reference measurement channel (144 kbps).....	319
C.3.4	DL reference measurement channel (384 kbps).....	321
C.4	Reference measurement channel for BTFD performance requirements	323
C.4.1	UL reference measurement channel for BTFD performance requirements.....	323
C.4.2	DL reference measurement channel for BTFD performance requirements.....	325
C.5	DL reference compressed mode parameters.....	328
Annex D (normative): Propagation Conditions		330
D.1	General	330
D.2	Propagation Conditions	330
D.2.1	Static propagation condition.....	330
D.2.2	Multi-path fading propagation conditions	330
D.2.3	Moving propagation conditions.....	330
D.2.4	Birth-Death propagation conditions	331
Annex E (normative): Downlink Physical Channels		332
E.1	General	332
E.2	Connection Set-up	332
E.2.1	Measurement without dedicated connection	332

E.3	During connection	332
E.3.1	Measurement of Tx Characteristics	332
E.3.2	Measurement of Rx Characteristics	333
E.3.3	Measurement of Performance requirements	333
E.3.4	Connection with open-loop transmit diversity mode	335
E.3.5	Connection with closed loop transmit diversity mode	336
E.4	W-CDMA Modulated Interferer	337
Annex F (normative): General test conditions and declarations		338
F.1	Acceptable uncertainty of Test System	338
F.1.1	Measurement of test environments	338
F.1.2	Measurement of transmitter	339
F.1.3	Measurement of receiver	341
F.1.4	Performance requirement	343
F.1.5	Requirements for support of RRM	346
F.2	Test Tolerances (This clause is informative)	349
F.2.1	Transmitter	350
F.2.2	Receiver	350
F.2.3	Performance requirements	351
F.2.4	Requirements for support of RRM	352
F.3	Interpretation of measurement results	353
F.4	Derivation of Test Requirements (This clause is informative)	354
F.5	Acceptable uncertainty of Test Equipment (This clause is informative)	372
F.5.1	Transmitter measurements	372
F.5.2	Receiver measurements	373
F.5.3	Performance measurements	373
F.6	General rules for statistical testing	373
F.6.1	Statistical testing of receiver BER/BLER performance	373
F.6.1.1	Error Definition	373
F.6.1.2	Test Method	373
F.6.1.3	Test Criteria	373
F.6.1.4	Calculation assumptions	374
F.6.1.4.1	Statistical independence	374
F.6.1.4.2	Applied formulas	374
F.6.1.4.3	Approximation of the distribution	374
F.6.1.5	Definition of good pass fail decision	375
F.6.1.6	Good balance between testtime and statistical significance	375
F.6.1.7	Pass fail decision rules	376
F.6.1.8	Test conditions for BER, BLER tests	378
F.6.1.9	Practical Use (informative)	380
F.6.1.10	Dual limit BLER tests	382
F.6.1.10.1	Description of the parameters for dual limit BLER tests	383
F.6.1.10.2	Pass fail decision rules	386
F.6.1.10.3	Test conditions for dual limit BLER tests	387
F.6.2	Statistical testing of RRM delay performance	387
F.6.2.1	Test Method	387
F.6.2.2	Bad Delay Ratio (ER)	387
F.6.2.3	Test Criteria	387
F.6.2.4	Calculation assumptions	388
F.6.2.4.1	Statistical independence	388
F.6.2.4.2	Applied formulas	388
F.6.2.4.3	Approximation of the distribution	388
F.6.2.5	Definition of good pass fail decision	388
F.6.2.6	Good balance between test-time and statistical significance	389
F.6.2.7	Pass fail decision rules	389
F.6.2.8	Test conditions for RRM delay tests and Combining of TPC commands test 1	390
F.6.2.9	Practical Use (informative)	390
Annex G (normative): Environmental conditions		392
G.1	General	392

G.2	Environmental requirements	392
G.2.1	Temperature	392
G.2.2	Voltage	392
G.2.3	Vibration.....	393
G.2.4	Specified frequency range	393
Annex H (normative): UE Capabilities (FDD).....		394
H.1	Radio Access and RF Baseline Implementation Capabilities:	394
H.2	Service Implementation Capabilities:	394
Annex I (normative): Default Message Contents.....		396
Annex J (informative): Information about special regional application of test cases and requirements.....		398
J.1	Japan.....	398
Annex K (informative): Change history		399
History		404

Foreword

This Technical Specification has been produced by the 3rd Generation Partnership Project (3GPP).

The contents of the present document are subject to continuing work within the TSG and may change following formal TSG approval. Should the TSG modify the contents of the present document, it will be re-released by the TSG with an identifying change of release date and an increase in version number as follows:

Version x.y.z

where:

- x the first digit:
 - 1 presented to TSG for information;
 - 2 presented to TSG for approval;
 - 3 or greater indicates TSG approved document under change control.
- y the second digit is incremented for all changes of substance, i.e. technical enhancements, corrections, updates, etc.
- z the third digit is incremented when editorial only changes have been incorporated in the document.

1 Scope

The present document specifies the measurement procedures for the conformance test of the user equipment (UE) that contain transmitting characteristics, receiving characteristics and performance requirements in FDD mode.

2 References

The following documents contain provisions which, through reference in this text, constitute provisions of the present document.

- References are either specific (identified by date of publication, edition number, version number, etc.) or non-specific.
- For a specific reference, subsequent revisions do not apply.
- For a non-specific reference, the latest version applies. In the case of a reference to a 3GPP document (including a GSM document), a non-specific reference implicitly refers to the latest version of that document *in the same Release as the present document*.

- [1] 3GPP TS 25.101 "UE Radio transmission and reception (FDD), Release 99".
- [2] 3GPP TS 25.133 "Requirements for Support of Radio Resource Management (FDD)".
- [3] 3GPP TS 34.108 "Common Test Environments for User Equipment (UE) Conformance Testing".
- [4] 3GPP TS 34.109 "Terminal logical test interface; Special conformance testing functions".
- [5] 3GPP TS 25.214 "Physical layer procedures (FDD)".
- [6] 3GPP TR 21.905 "Vocabulary for 3GPP Specifications".
- [7] 3GPP TR 25.990 "Vocabulary".
- [8] 3GPP TS 25.331: "Radio Resource Control (RRC); Protocol Specification".
- [9] 3GPP TS 25.433 "UTRAN Iub Interface NBAP Signalling".
- [10] ITU-R Recommendation SM.329: "Spurious emissions".
- [11] 3GPP TS 25.304: "UE Procedures in Idle Mode and Procedures for Cell Reselection in Connected Mode".
- [12] 3GPP TS 25.303: "Interlayer Procedures in Connected Mode".
- [13] 3GPP TS 25.321: "Medium Access Control (MAC) protocol specification".
- [14] 3GPP TS 25.213: "Spreading and modulation (FDD)".
- [15] 3GPP TS 25.223: "Spreading and modulation (TDD)".
- [16] ETSI ETR 273-1-2: "Improvement of radiated methods of measurement (using test sites) and evaluation of the corresponding measurement uncertainties; Part 1: Uncertainties in the measurement of mobile radio equipment characteristics; Sub-part 2: Examples and annexes".
- [17] 3GPP TR 25.926: "UE Radio Access Capabilities".
- [18] 3GPP TR 21.904: "UE capability requirements".
- [19] 3GPP TS 25.211: "Physical channels and mapping of transport channels onto physical channels (FDD)".
- [20] 3GPP TS 05.08: "Digital cellular telecommunications system (Phase 2+); Radio subsystem link control".

- [21] 3GPP TS 34.123-1: "User Equipment (UE) Conformance Specification; Part 1: Protocol Conformance Specification".
- [22] 3GPP TS 25.215: "Physical Layer – Measurements (FDD)".
- [23] 3GPP TS 25.101 "UE Radio transmission and reception (FDD), Release 5".

3 Definitions, symbols, abbreviations and equations

Definitions, symbols, abbreviations and equations used in the present document are listed in TR 21.905 [5] and TR 25.990 [6].

Terms are listed in alphabetical order in this clause.

3.1 Definitions

For the purpose of the present document, the following additional terms and definitions apply:

Maximum Output Power: This is a measure of the maximum power the UE can transmit (i.e. the actual power as would be measured assuming no measurement error) in a bandwidth of at least $(1 + \alpha)$ times the chip rate of the radio access mode. The period of measurement shall be at least one timeslot.

Nominal Maximum Output Power: This is the nominal power defined by the UE power class.

Mean power: When applied to a W-CDMA modulated signal this is the power (transmitted or received) in a bandwidth of at least $(1 + \alpha)$ times the chip rate of the radio access mode. The period of measurement shall be at least one timeslot unless otherwise stated.

RRC filtered mean power: The mean power as measured through a root raised cosine filter with roll-off factor α and a bandwidth equal to the chip rate of the radio access mode.

NOTE 1: The RRC filtered mean power of a perfectly modulated W-CDMA signal is 0.246 dB lower than the mean power of the same signal.

NOTE 2: The roll-off factor α is defined in 25.101 clause 6.8.1.

3.2 Symbols

For the purposes of the present document, the following symbols apply:

[...] Values included in square bracket must be considered for further studies, because it means that a decision about that value was not taken

3.3 Abbreviations

For the purpose of the present document, the following additional abbreviations apply:

AFC	Automatic Frequency Control
ASD	Acceleration Spectral Density
ATT	Attenuator
BER	Bit Error Ratio
BLER	Block Error Ratio
BTFD	Blind Transport Format Detection
EVM	Error Vector Magnitude
FDR	False transmit format Detection Ratio. A false Transport Format detection occurs when the receiver detects a different TF to that which was transmitted, and the decoded transport block(s) for this incorrect TF passes the CRC check(s).
HYB	Hybrid
IM	Intermodulation

ITP	Initial Transmission Power control mode
OBW	Occupied Bandwidth
OCNS	Orthogonal Channel Noise Simulator, a mechanism used to simulate the users or control signals on the other orthogonal channels of a downlink
PAR	Peak to Average Ratio
P-CCPCH	Primary Common Control Physical Channel
P-CPICH	Primary Common Pilot Channel
PCDE	Peak Code Domain Error
RBW	Resolution Bandwidth
RRC	Root-Raised Cosine
S-CCPCH	Secondary Common Control Physical Channel
S-CPICH	Secondary Common Pilot Channel
SCH	Synchronisation Channel consisting of Primary and Secondary synchronisation channels
SS	System Simulator; see Annex A for description
TGCFN	Transmission Gap Connection Frame Number
TGD	Transmission Gap Distance
TGL	Transmission Gap Length
TGPL	Transmission Gap Pattern Length
TGPRC	Transmission Gap Pattern Repetition Count
TGSN	Transmission Gap Starting Slot Number

3.4 Equations

For the purpose of the present document, the following additional equations apply:

$\frac{CPICH_E_c}{I_{or}}$ The ratio of the received energy per PN chip of the CPICH to the total transmit power spectral density at the Node B (SS) antenna connector.

$\frac{DPCH_E_c}{I_{or}}$ The ratio of the transmit energy per PN chip of the DPCH to the total transmit power spectral density at the Node B (SS) antenna connector.

$\frac{DPCCH_E_c}{I_{or}}$ The ratio of the transmit energy per PN chip of the DPCCH to the total transmit power spectral density at the Node B (SS) antenna connector.

$\frac{DPDCH_E_c}{I_{or}}$ The ratio of the transmit energy per PN chip of the DPDCH to the total transmit power spectral density at the Node B (SS) antenna connector.

F_{uw} Frequency of unwanted signal. This is specified in bracket in terms of an absolute frequency(s) or a frequency offset from the assigned channel frequency.

I_{Node_B} Interference signal power level at Node B in dBm, which is broadcasted on BCH.

I_{oac} The power spectral density (integrated in a bandwidth of $(1+\alpha)$ times the chip rate and normalized to the chip rate) of the adjacent frequency channel as measured at the UE antenna connector.

I_{oc} The power spectral density (integrated in a noise bandwidth equal to the chip rate and normalized to the chip rate) of a band limited white noise source (simulating interference from cells, which are not defined in a test procedure) as measured at the UE antenna connector.

I_{or} The total transmit power spectral density (integrated in a bandwidth of $(1+\alpha)$ times the chip rate and normalized to the chip rate) of the downlink signal at the Node B antenna connector

\hat{I}_{or} The received power spectral density (integrated in a bandwidth of $(1+\alpha)$ times the chip rate and normalized to the chip rate) of the downlink signal as measured at the UE antenna connector.

I_{ouw} Unwanted signal power level.

$P\text{-CCPCH}_{E_c}$	Average (note) energy per PN chip for P-CCPCH.
$P\text{-CCPCH} \frac{E_c}{I_o}$	The ratio of the received P-CCPCH energy per chip to the total received power spectral density at the UE antenna connector.
$\frac{P\text{-CCPCH}_{E_c}}{I_{or}}$	The ratio of the average (note) transmit energy per PN chip for the P-CCPCH to the total transmit power spectral density.
$P\text{-CPICH}_{E_c}$	Average (note) energy per PN chip for P-CPICH.
$PICH_{E_c}$	Average (note) energy per PN chip for PICH.
$\frac{PICH_{E_c}}{I_{or}}$	The ratio of the received energy per PN chip of the PICH to the total transmit power spectral density at the Node B (SS) antenna connector.
<REFSENS>	Reference sensitivity
<REF \hat{I}_{or} >	Reference \hat{I}_{or}
SCH_{E_c}	Average (note) energy per PN chip for SCH.
$S\text{-CPICH}_{E_c}$	Average (note) energy per PN chip for S-CPICH.

NOTE: Averaging period for energy/power of discontinuously transmitted channels should be defined.

NOTE: The units of Power Spectral Density (PSD) are extensively used in this document. PSD is a function of power versus frequency and when integrated across a given bandwidth, the function represents the mean power in such a bandwidth. When the mean power is normalised to (divided by) the chip-rate it represents the mean energy per chip. Some signals are directly defined in terms of energy per chip, (DPCH_{E_c} and P-CPICH_{E_c}) and others defined in terms of PSD (I_{oac} , I_{oc} , and \hat{I}_{or}). There also exist quantities that are a ratio of energy per chip to PSD (DPCH_{E_c}/ I_{or} , E_c/I_{or} etc.). This is the common practice of relating energy magnitudes in communication systems.

It can be seen that if both energy magnitudes in the ratio are divided by time, the ratio is converted from an energy ratio to a power ratio, which is more useful from a measurement point of view. It follows that an energy per chip of X dBm/3.84 MHz can be expressed as a mean power per chip of X dBm. Similarly, a signal PSD of Y dBm/3.84 MHz can be expressed as a signal power of Y dBm.

4 Frequency bands and channel arrangement

4.1 General

The information presented in this clause is based on a chip rate of 3,84 Mcps.

NOTE: Other chip rates may be considered in future releases.

4.2 Frequency bands

a) UTRA/FDD is designed to operate in either of the following paired bands:

Operating Band	UL Frequencies UE transmit, Node B receive	DL frequencies UE receive, Node B transmit
I	1920 – 1980 MHz	2110 –2170 MHz
II	1850 –1910 MHz	1930 –1990 MHz
III	1710-1785 MHz	1805-1880 MHz

- b) Deployment in other frequency bands is not precluded.

4.3 TX–RX frequency separation

- a) UTRA/FDD is designed to operate with the following TX-RX frequency separation.

Operating Band	TX-RX frequency separation
I	190 MHz
II	80 MHz
III	95 MHz

- b) UTRA/FDD can support both fixed and variable transmit to receive frequency separation.
- c) The use of other transmit to receive frequency separations in existing or other frequency bands shall not be precluded.

4.4 Channel arrangement

4.4.1 Channel spacing

The nominal channel spacing is 5 MHz, but this can be adjusted to optimise performance in a particular deployment scenario.

4.4.2 Channel raster

The channel raster is 200 kHz, which for all bands except Band II means that the centre frequency must be an integer multiple of 200 kHz. In Band II, 12 additional centre frequencies are specified according to the table in 4.1a and the centre frequencies for these channels are shifted 100 kHz relative to the normal raster.

4.4.3 Channel number

The carrier frequency is designated by the UTRA Absolute Radio Frequency Channel Number (UARFCN). The values of the UARFCN are as follows.

Table 4.1: UARFCN definition

Uplink	$N_u = 5 * F_{\text{uplink}}$	$0,0 \text{ MHz} \leq F_{\text{uplink}} \leq 3\,276,6 \text{ MHz}$ where F_{uplink} is the uplink frequency in MHz
Downlink	$N_d = 5 * F_{\text{downlink}}$	$0,0 \text{ MHz} \leq F_{\text{downlink}} \leq 3\,276,6 \text{ MHz}$ where F_{downlink} is the downlink frequency in MHz

Table 4.1a: UARFCN definition (Band II additional channels)

	UARFCN	Carrier frequency [MHz]
Uplink	$N_u = 5 * (F_{\text{uplink}} - 1850.1 \text{ MHz})$	$F_{\text{uplink}} = 1852.5, 1857.5, 1862.5, 1867.5,$ $1872.5, 1877.5,$ $1882.5, 1887.5, 1892.5, 1897.5, 1902.5, 1907.5$
Downlink	$N_d = 5 * (F_{\text{downlink}} - 1850.1 \text{ MHz})$	$F_{\text{downlink}} = 1932.5, 1937.5, 1942.5, 1947.5,$ $1952.5, 1957.5,$ $1962.5, 1967.5, 1972.5, 1977.5, 1982.5, 1987.5$

4.4.4 UARFCN

The following UARFCN range shall be supported for each paired band.

Table 4.2: UTRA Absolute Radio Frequency Channel Number

Operating Band	Uplink UE transmit, Node B receive	Downlink UE receive, Node B transmit
I	9 612 to 9 888	10 562 to 10 838
II	9 262 to 9 538 and 12, 37, 62, 87, 112, 137, 162, 187, 212, 237, 262, 287	9 662 to 9 938 and 412, 437, 462, 487, 512, 537, 562, 587, 612, 637, 662, 687
III	8562 to 8913	9037 to 9388

5 Transmitter Characteristics

5.1 General

Transmitting performance test of the UE is implemented during communicating with the SS via air interface. The procedure is using normal call protocol until the UE is communicating on traffic channel basically. On the traffic channel, the UE provides special function for testing that is called Logical Test Interface and the UE is tested using this function. (Refer to TS 34.109 [4]).

Transmitting or receiving bit/symbol rate for test channel is shown in table 5.1.

Table 5.1: Bit / Symbol rate for Test Channel

Type of User Information	User bit rate	DL DPCH symbol rate	UL DPCH bit rate	Remarks
12,2 kbps reference measurement channel	12,2 kbps	30 kpsps	60 kbps	Standard Test

Unless detailed the transmitter characteristic are specified at the antenna connector of the UE. For UE with integral antenna only, a reference antenna with a gain of 0 dBi is assumed. Transmitter characteristics for UE(s) with multiple antennas/antenna connectors are FFS.

The UE antenna performance has a significant impact on system performance, and minimum requirements on the antenna efficiency are therefore intended to be included in future versions of the present document. It is recognised that different requirements and test methods are likely to be required for the different types of UE.

All the parameters in clause 5 are defined using the UL reference measurement channel (12,2 kbps) specified in clause C.2.1 and unless stated otherwise, with the UL power control ON.

The common RF test conditions of Tx Characteristics are defined in clause E.3.1, and each test conditions in this clause (clause 5) should refer clause E.3.1. Individual test conditions are defined in the paragraph of each test.

5.2 Maximum Output Power

5.2.1 Definition and applicability

The nominal maximum output power and its tolerance are defined according to the Power Class of the UE.

The maximum output power is a measure of the maximum power the UE can transmit (i.e. the actual power as would be measured assuming no measurement error) in a bandwidth of at least $(1 + \alpha)$ times the chip rate of the radio access mode. The period of measurement shall be at least one timeslot.

The requirements and this test apply to all types of UTRA for the FDD UE.

5.2.2 Minimum Requirements

The UE maximum output power shall be within the nominal value and tolerance specified in table 5.2.1 even for the multi-code transmission mode.

Table 5.2.1: Nominal Maximum Output Power

Operating Band	Power Class 1		Power Class 2		Power Class 3		Power Class 4	
	Power (dBm)	Tol (dB)	Power (dBm)	Tol (dB)	Power (dBm)	Tol (dB)	Power (dBm)	Tol (dB)
Band I	+33	+1/-3	+27	+1/-3	+24	+1/-3	+21	+2/-2
Band II	-	-	-	-	+24	+1/-3	+21	+2/-2
Band III	-	-	-	-	+24	+1/-3	+21	+2/-2

The normative reference for this requirement is TS 25.101 [23] clause 6.2.1.

5.2.3 Test purpose

To verify that the error of the UE maximum output power does not exceed the range prescribed by the nominal maximum output power and tolerance in table 5.2.1.

An excess maximum output power has the possibility to interfere to other channels or other systems. A small maximum output power decreases the coverage area.

5.2.4 Method of test

5.2.4.1 Initial conditions

Test environment: normal, TL/VL, TL/VH, TH/VL, TH/VH; see clauses G.2.1 and G.2.2.

Frequencies to be tested: low range, mid range, high range; see clause G.2.4.

- 1) Connect the SS to the UE antenna connector as shown in figure A.1.
- 2) A call is set up according to the Generic call setup procedure.
- 3) Enter the UE into loopback test mode and start the loopback test.

See TS 34.108 [3] and TS 34.109 [4] for details regarding generic call setup procedure and loopback test.

5.2.4.2 Procedure

- 1) Set and send continuously Up power control commands to the UE.
- 2) Measure the mean power of the UE in a bandwidth of at least $(1 + \alpha)$ times the chip rate of the radio access mode. The mean power shall be averaged over at least one timeslot.

5.2.5 Test requirements

The maximum output power, derived in step 2), shall not exceed the range prescribed by the nominal maximum output power and tolerance in table 5.2.2.

Table 5.2.2: Nominal Maximum Output Power

Operating Band	Power Class 1		Power Class 2		Power Class 3		Power Class 4	
	Power (dBm)	Tol (dB)	Power (dBm)	Tol (dB)	Power (dBm)	Tol (dB)	Power (dBm)	Tol (dB)
Band I	+33	+1,7/-3,7	+27	+1,7/-3,7	+24	+1,7/-3,7	+21	+2,7/-2,7
Band II	-	-	-	-	+24	+1,7/-3,7	+21	+2,7/-2,7
Band III	-	-	-	-	+24	+1,7/-3,7	+21	+2,7/-2,7

NOTE: If the above Test Requirement differs from the Minimum Requirement then the Test Tolerance applied for this test is non-zero. The Test Tolerance for this test is defined in clause F.2 and the explanation of how the Minimum Requirement has been relaxed by the Test Tolerance is given in clause F.4.

5.3 Frequency Error

5.3.1 Definition and applicability

The frequency error is the difference between the RF modulated carrier frequency transmitted from the UE and the assigned frequency. The UE transmitter tracks to the RF carrier frequency received from the Node B. These signals will have an apparent error due to Node B frequency error and Doppler shift. In the later case, signals from the Node B must be averaged over sufficient time that errors due to noise or interference are allowed for within the minimum requirements specified in 5.3.2.

The UE shall use the same frequency source for both RF frequency generation and the chip clock.

The requirements and this test apply to all types of UTRA for the FDD UE.

5.3.2 Minimum Requirements

The UE modulated carrier frequency shall be accurate to within $\pm 0,1$ ppm observed over a period of one timeslot compared to the carrier frequency received from the Node B.

The normative reference for this requirement is TS 25.101 [1] clause 6.3.

5.3.3 Test purpose

To verify that the UE carrier frequency error does not exceed $\pm 0,1$ ppm.

An excess error of the carrier frequency increases the transmission errors in the up link own channel.

This test verifies the ability of the receiver to derive correct frequency information for the transmitter, when locked to the DL carrier frequency.

5.3.4 Method of test

5.3.4.1 Initial conditions

Test environment: normal, TL/VL, TL/VH, TH/VL, TH/VH, vibration; see clauses G.2.1, G.2.2 and G.2.3.

Frequencies to be tested: low range, mid range, high range; see clause G.2.4.

- 1) Connect the SS to the UE antenna connector as shown in figure A.1.
- 2) A call is set up according to the Generic call setup procedure, and RF parameters (DPCH_Ec and \hat{I}_{or}) are set up according to table 5.3. The relative power level of other downlink physical channels to the DPCH_Ec are set up according to clause E.3.1.
- 3) Enter the UE into loopback test mode and start the loopback test.

See TS 34.108 [3] and TS 34.109 [4] for details regarding generic call setup procedure and loopback test.

Table 5.3: Test parameters for Frequency Error

Parameter	Level / Status	Unit
DPCH_Ec	-117	dBm / 3,84 MHz
\hat{I}_{or}	-106,7	dBm / 3,84 MHz

5.3.4.2 Procedure

- 1) Set and send continuously Up power control commands to the UE until the UE reaches its maximum output power.
- 2) Measure the frequency error Δf , at the UE antenna connector using the Global In-Channel-Tx-test (annex B).

5.3.5 Test Requirements

For all measurements, the frequency error, derived in step 2), shall not exceed $\pm(0,1 \text{ ppm} + 10 \text{ Hz})$.

NOTE: If the above Test Requirement differs from the Minimum Requirement then the Test Tolerance applied for this test is non-zero. The Test Tolerance for this test is defined in clause F.2 and the explanation of how the Minimum Requirement has been relaxed by the Test Tolerance is given in clause F.4.

5.4 Output Power Dynamics in the Uplink

Power control is used to limit the interference level.

5.4.1 Open Loop Power Control in the Uplink

5.4.1.1 Definition and applicability

Open loop power control in the uplink is the ability of the UE transmitter to set its output power to a specific value. This function is used for PRACH transmission and based on the information from Node B using BCCH and the downlink received signal power level of the CPICH. The information from Node B includes transmission power of CPICH and uplink interference power level.

The requirements and this test apply to all types of UTRA for the FDD UE.

5.4.1.2 Minimum requirements

The UE open loop power is defined as the mean power in a timeslot or ON power duration, whichever is available.

The UE open loop power control tolerance is given in table 5.4.1.1.

Table 5.4.1.1: Open loop power control tolerance

Normal conditions	$\pm 9 \text{ dB}$
Extreme conditions	$\pm 12 \text{ dB}$

The reference for this requirement is TS 25.101 [1] clause 6.4.1.

5.4.1.3 Test purpose

The power measured by the UE of the received signal and the signalled BCCH information are used by the UE to control the power of the UE transmitted signal with the target to transmit at the lowest power acceptable for proper communication.

The test stresses the ability of the receiver to measure the received power correctly over the receiver dynamic range.

The test purpose is to verify that the UE open loop power control tolerance does not exceed the described value shown in table 5.4.1.1.

An excess error of the open loop power control decreases the system capacity.

5.4.1.4 Method of test

5.4.1.4.1 Initial conditions

Test environment: normal, TL/VL, TL/VH, TH/VL, TH/VH; see clauses G.2.1 and G.2.2.

Frequencies to be tested: low range, mid range, high range; see clause G.2.4.

- 1) Connect the SS to the UE antenna connector as shown in figure A.1.
- 2) A call is set up according to the Generic call setup procedure, and \hat{I}_{or} is set up according to table 5.4.1.2. The relative power level of downlink physical channels to I_{or} are set up according to clause E.2.1. The RACH procedure within the call setup is used for the test.

See TS 34.108 [3] for details regarding generic call setup procedure.

Table 5.4.1.2: Test parameters for Open Loop Power Control (UE)

Parameter	Level / Status	Unit
\hat{I}_{or}	See table 5.4.1.3	dBm / 3,84 MHz

Table 5.4.1.3: Test parameters for Open Loop Power Control (SS)

Parameter	RX Upper dynamic end	RX-middle	RX-Sensitivity level
\hat{I}_{or} (note 3)	-25,0 dBm / 3,84 MHz	-65,7 dBm / 3,84 MHz	-106,7 dBm / 3,84 MHz
CPICH_RSCP (notes 3 and 4)	-28,3 dBm	-69 dBm	-110 dBm
Primary CPICH DL TX power	+19 dBm	+28 dBm	+19 dBm
Simulated path loss = Primary CPICH DL TX power – CPICH_RSCP	+47,3 dB	+97 dB	+129 dB
UL interference	-75 dBm	-101 dBm	-110 dBm
Constant Value	-10 dB	-10 dB	-10 dB
Expected nominal UE TX power (note 5)	-37,7 dBm	-14 dBm	+9 dBm (note 2)
NOTE 1: While the SS transmit power shall cover the receiver input dynamic range, the logical parameters: Primary CPICH DL TX power, UL interference, Constant Value are chosen to achieve a UE TX power, located within the TX output power dynamic range of a class 4 UE.			
NOTE 2: Nominal TX output power 9 dBm allows to check the open loop power algorithm within the entire tolerance range (9 dBm ± 12 dB; 9 dBm + 12 dB = 21 dBm = max power class 4).			
NOTE 3: The power level of S-CCPCH should be defined because S-CCPCH is transmitted during Preamble RACH transmission period. The power level of S-CCPCH is temporarily set to -10,3 dB relative to \hat{I}_{or} . However, it is necessary to check whether the above S-CCPCH level is enough to establish a connection with the reference measurement channels.			
NOTE 4: The purpose of this parameter is to calculate the Expected nominal UE TX power.			
NOTE 5: The Expected nominal UE TX power is calculated by using the equation in the clause 8.5.7 Open Loop Power Control of TS 25.331 [8].			

5.4.1.4.2 Procedure

- 1) Set the TX output level of the SS to obtain \hat{I}_{or} at the UE antenna connector. \hat{I}_{or} shall be according to table 5.4.1.3 (-25 dBm / 3,84 MHz).
- 2) Measure the first RACH preamble mean power of the UE.
- 3) Repeat the above measurement for all SS levels in table 5.4.1.3.

5.4.1.5 Test requirements

The deviation with respect to the Expected nominal UE TX power (table 5.4.1.3), derived in step 2), shall not exceed the prescribed tolerance in table 5.4.1.1.

5.4.2 Inner Loop Power Control in the Uplink

5.4.2.1 Definition and applicability

Inner loop power control in the uplink is the ability of the UE transmitter to adjust its output power in accordance with one or more TPC commands received in the downlink.

The power control step is the change in the UE transmitter output power in response to a single TPC command, TPC_cmd, derived at the UE.

This clause does not cover all the requirements of compressed mode or soft handover.

The requirements and this test apply to all types of UTRA for the FDD UE.

5.4.2.2 Minimum requirements

The UE transmitter shall have the capability of changing the output power with a step size of 1 dB, 2 dB and 3 dB according to the value of Δ_{TPC} or $\Delta_{\text{RP-TPC}}$, in the slot immediately after the TPC_cmd can be derived.

- a) The transmitter output power step due to inner loop power control shall be within the range shown in table 5.4.2.1.
- b) The transmitter aggregate output power step due to inner loop power control shall be within the range shown in table 5.4.2.2. Here a TPC_cmd group is a set of TPC_cmd values derived from a corresponding sequence of TPC commands of the same duration.

The inner loop power step is defined as the relative power difference between the mean power of the original (reference) timeslot and the mean power of the target timeslot, not including the transient duration. The transient duration is from 25 μ s before the slot boundary to 25 μ s after the slot boundary.

Table 5.4.2.1: Transmitter power control range

TPC_cmd	Transmitter power control range (all units are in dB)					
	1 dB step size		2 dB step size		3 dB step size	
	Lower	Upper	Lower	Upper	Lower	Upper
+1	+0,5	+1,5	+1	+3	+1,5	+4,5
0	-0,5	+0,5	-0,5	+0,5	-0,5	+0,5
-1	-0,5	-1,5	-1	-3	-1,5	-4,5

Table 5.4.2.2: Transmitter aggregate power control tolerance

TPC_cmd group	Transmitter power control range after 10 equal TPC_cmd group (all units are in dB)				Transmitter power control range after 7 equal TPC_cmd groups (all units are in dB)	
	1 dB step size		2 dB step size		3 dB step size	
	Lower	Upper	Lower	Upper	Lower	Upper
+1	+8	+12	+16	+24	+16	+26
0	-1	+1	-1	+1	-1	+1
-1	-8	-12	-16	-24	-16	-26
0,0,0,0,+1	+6	+14	N/A	N/A	N/A	N/A
0,0,0,0,-1	-6	-14	N/A	N/A	N/A	N/A

The UE shall meet the above requirements for inner loop power control over the power range bounded by the Minimum output power as defined in clause 5.4.3.2, and the Maximum output power supported by the UE (i.e. the actual power as would be measured assuming no measurement error). This power shall be in the range specified for the power class of the UE in clause 5.2.2.

NOTE: 3 dB inner loop power control steps are only used in compressed mode.

The reference for this requirement is TS 25.101 [1] clause 6.4.2.1.1.

The requirements for the derivation of TPC_cmd are detailed in TS 25.214 [5] clauses 5.1.2.2.2 and 5.1.2.2.3.

5.4.2.3 Test purpose

- To verify that the UE inner loop power control size and response is meet to the described value shown in clause 5.4.2.2.
- To verify that TPC_cmd is correctly derived from received TPC commands.

An excess error of the inner loop power control decreases the system capacity.

The UE shall be tested for the requirements for inner loop power control over the power range bounded by the Min power threshold for test and the Max power threshold for test.

The Min power threshold for test is defined as the Minimum Output Power Test Requirement (clause 5.4.3.5).

The Max power threshold for test is defined as the Measured Maximum output power of the UE in the relevant Step of the test (using the same method as in clause 5.2.4.2 step 2) minus the Test Tolerance specified for test 5.2 Maximum Output Power in table F.2.1.

For the final power step adjacent to the Min or Max power threshold for test, the lower step size requirement does not apply.

5.4.2.4 Method of test

5.4.2.4.1 Initial conditions

Test environment: normal; see clauses G.2.1 and G.2.2.

Frequencies to be tested: mid range; see clause G.2.4.

- 1) Connect the SS to the UE antenna connector as shown in figure A.1.
- 2) A call is set up according to the Generic call setup procedure specified in TS34.108 [3] sub clause 7.3.2, with the following exception for information elements in RADIO BEARER SETUP message. With this exception, the Power Control Algorithm for the Uplink is set to algorithm 2.

Table 5.4.2.4.1: Contents of RADIO BEARER SETUP message: AM or UM

Information Element	Value/Remark
CHOICE channel requirement - Power Control Algorithm	Uplink DPCH info Algorithm 2

- 3) Enter the UE into loopback test mode and start the loopback test.

See TS 34.108 [3] and TS 34.109 [4] for details regarding generic call setup procedure and loopback test.

5.4.2.4.2

Procedure

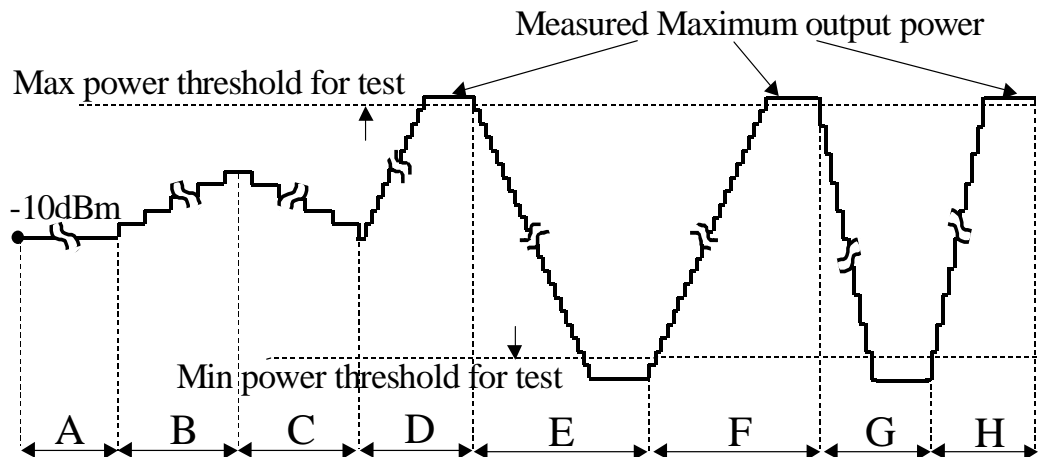

Figure 5.4.2.4 Inner Loop Power Control Test Steps

- 1) Before proceeding with paragraph (2) (Step A) below, set the output power of the UE, measured at the UE antenna connector, to be in the range -10 ± 9 dBm. This may be achieved by setting the downlink signal (\hat{I}_{or}) to yield an appropriate open loop output power and/or by generating suitable downlink TPC commands from the SS.
- 2) Step A: Transmit a sequence of at least 30 and no more than 60 TPC commands, which shall commence at a frame boundary and last for a whole number of frames, and which shall contain:
 - no sets of 5 consecutive "0" or "1" commands which commence in the 1st, 6th or 11th slots of a frame;
 - at least one set of 5 consecutive "0" commands which does not commence in the 1st, 6th or 11th slots of a frame;
 - at least one set of 5 consecutive "1" commands which does not commence in the 1st, 6th or 11th slots of a frame.

The following is an example of a suitable sequence of TPC commands:

```
100000101010101111101000001010101011111010000010101010111110
```

- 3) Step B: Transmit a sequence of 50 TPC commands with the value 1.
- 4) Step C: Transmit a sequence of 50 TPC commands with the value 0.
- 5) Step D: Transmit the PHYSICAL CHANNEL RECONFIGURATION message to reconfigure the uplink channel in order to set the Power Control Algorithm to algorithm 1, and the TPC step size to 1 dB. Contents of the message is specified in the table 5.4.2.4.2.A. After the PHYSICAL CHANNEL RECONFIGURATION COMPLETE message from the UE is received, transmit a sequence of TPC commands with the value 1 until the UE output power is above the maximum power threshold.
- 6) Step E: Transmit a sequence of 150 (note 1) TPC commands with the value 0.
- 7) Step F: Transmit a sequence of 150 (note 1) TPC commands with the value 1.
- 8) Step G: Transmit the PHYSICAL CHANNEL RECONFIGURATION message to reconfigure the uplink channel in order to set the TPC step size to 2 dB (with the Power Control Algorithm remaining as algorithm 1). Contents of the message is specified in the table 5.4.2.4.2.B. After the PHYSICAL CHANNEL RECONFIGURATION COMPLETE message from the UE is received, transmit a sequence of TPC commands with the value 1 until the UE output power is above the maximum power threshold. Transmit a sequence of 75 (note 1) TPC commands with the value 0.

9) Step H: Transmit a sequence of 75 (note 1) TPC commands with the value 1.

10) During steps A to H the mean power of every slot shall be measured, with the following exceptions:

- In steps D and F, measurement of the mean power is not required in slots after the 10th slot after the mean power has exceeded the maximum power threshold;
- In steps E and G, measurement of the mean power is not required in slots after the 10th slot after the mean power has fallen below the minimum power threshold.

The transient periods of 25 μ s before each slot boundary and 25 μ s after each slot boundary shall not be included in the power measurements.

NOTE 1: These numbers of TPC commands are given as examples. The actual number of TPC commands transmitted in these steps shall be at least 10 more than the number required to ensure that the UE reaches the relevant maximum or minimum power threshold in each step, as shown in figure 5.4.2.4.

NOTE 2: In order to make it more practical to measure the entire power control dynamic range (between min power threshold and max power threshold with suitable margins), it is permissible to segment the power control sequences into smaller subsequence. For example, Step-E can be divided into different stages while still fulfilling the purpose of the test to measure the entire dynamic range.

Table 5.4.2.4.2.A: PHYSICAL CHANNEL RECONFIGURATION message for step D (step 5)

Information Element	Value/Remark
Message Type	
UE Information Elements -RRC transaction identifier -Integrity check info -Integrity protection mode info -Ciphering mode info -Activation time -New U-RNTI -New C-RNTI -RRC State Indicator -UTRAN DRX cycle length coefficient	0 Not Present Not Present Not Present Not Present Not Present Not Present CELL_DCH Not Present
CN Information Elements -CN Information info	Not Present
UTRAN mobility information elements -URA identity	Not Present
RB information elements -Downlink counter synchronisation info	Not Present
PhyCH information elements -Frequency info	Not Present
Uplink radio resources -Maximum allowed UL TX power -CHOICE channel requirement -Uplink DPCH power control info -CHOICE mode -DPCCH Power offset -PC Preamble -SRB delay -Power Control Algorithm -TPC step size -CHOICE mode -Scrambling code type -Scrambling code number -Number of DPDCH -spreading factor -TFCI existence -Number of FBI bits -Puncturing Limit	Not Present Uplink DPCH info FDD -6dB 1 frame 7 frames Algorithm 1 1dB FDD Long 0 1 64 TRUE Not Present(0) 1
Downlink radio resources -CHOICE mode -Downlink PDSCH information -Downlink information common for all radio links -Downlink information per radio link list	FDD Not Present Not Present Not Present

Table 5.4.2.4.2.B: PHYSICAL CHANNEL RECONFIGURATION message for step G (step 8)

Information Element	Value/Remark
Message Type	
UE Information Elements -RRC transaction identifier -Integrity check info -Integrity protection mode info -Ciphering mode info -Activation time -New U-RNTI -New C-RNTI -RRC State Indicator -UTRAN DRX cycle length coefficient	0 Not Present Not Present Not Present Not Present Not Present Not Present CELL_DCH Not Present
CN Information Elements -CN Information info	Not Present
UTRAN mobility information elements -URA identity	Not Present
RB information elements -Downlink counter synchronisation info	Not Present
PhyCH information elements -Frequency info	Not Present
Uplink radio resources -Maximum allowed UL TX power -CHOICE channel requirement -Uplink DPCH power control info -CHOICE mode -DPCCH Power offset -PC Preamble -SRB delay -Power Control Algorithm -TPC step size -CHOICE mode -Scrambling code type -Scrambling code number -Number of DPDCH -spreading factor -TFCI existence -Number of FBI bits -Puncturing Limit	Not Present Uplink DPCH info FDD -6dB 1 frame 7 frames Algorithm 1 2dB FDD Long 0 1 64 TRUE Not Present(0) 1
Downlink radio resources -CHOICE mode -Downlink PDSCH information -Downlink information common for all radio links -Downlink information per radio link list	FDD Not Present Not Present Not Present

5.4.2.5 Test requirements

- During Step A, the difference in mean power between adjacent slots shall be within the prescribed range for a TPC_cmd of 0, as given in table 5.4.2.1.
- During Step A, the change in mean power over 10 consecutive slots shall be within the prescribed range for a TPC_cmd group of 0, as given in table 5.4.2.2.
- During Step B, the difference in mean power between adjacent slots shall be within the prescribed range given in table 5.4.2.1, given that every 5th TPC_cmd should have the value +1, with a step size of 1 dB, and all other TPC_cmd should have the value 0.
- During Step B, the change in mean power over 50 consecutive slots shall be within the prescribed range for a TPC_cmd group of {0,0,0,0,+1}, as given in table 5.4.2.2.
- During Step C, the difference in mean power between adjacent slots shall be within the prescribed range given in table 5.4.2.1, given that every 5th TPC_cmd should have the value -1, with a step size of 1 dB, and all other TPC_cmd should have the value 0.

- f) During Step C, the change in mean power over 50 consecutive slots shall be within the prescribed range for a TPC_cmd group of {0,0,0,0,-1}, as given in table 5.4.2.2.
- g) During Step E, the difference in mean power between adjacent slots shall be within the prescribed range given in table 5.4.2.1 for a TPC_cmd of -1 and step size of 1 dB. This applies when the original (reference) timeslot power and the target timeslot power are between the Min power threshold for test and the Max power threshold for test derived from the Measured Maximum output power in Step D. For the power step adjacent to the Min or Max power threshold for test, the lower step size requirement does not apply.
- h) During Step E, the change in mean power over 10 consecutive slots shall be within the prescribed range for a TPC_cmd group of -1, and step size of 1 dB as given in table 5.4.2.2. This applies when the original (reference) timeslot power and the target timeslot power are between the Min power threshold for test and the Max power threshold for test derived from the Measured Maximum output power in Step D. The power step adjacent to the Min or Max power threshold for test should not be part of the 10 consecutive slots tested.
- i) During Step F, the difference in mean power between adjacent slots shall be within the prescribed range given in table 5.4.2.1 for a TPC_cmd of +1 and step size of 1 dB. This applies when the original (reference) timeslot power and the target timeslot power are between the Min power threshold for test and the Max power threshold for test derived from the Measured Maximum output power in Step F. For the power step adjacent to the Min or Max power threshold for test, the lower step size requirement does not apply.
- j) During Step F, the change in mean power over 10 consecutive slots shall be within the prescribed range for a TPC_cmd group of +1, and step size of 1 dB as given in table 5.4.2.2. This applies when the original (reference) timeslot power and the target timeslot power are between the Min power threshold for test and the Max power threshold for test derived from the Measured Maximum output power in Step F. The power step adjacent to the Min or Max power threshold for test should not be part of the 10 consecutive slots tested.
- k) During Step G, the difference in mean power between adjacent slots shall be within the prescribed range given in table 5.4.2.1 for a TPC_cmd of -1 and step size of 2 dB. This applies when the original (reference) timeslot power and the target timeslot power are between the Min power threshold for test and the Max power threshold for test derived from the Measured Maximum output power in Step F. For the power step adjacent to the Min or Max power threshold for test, the lower step size requirement does not apply.
- l) During Step G, the change in mean power over 10 consecutive slots shall be within the prescribed range for a TPC_cmd group of -1, and step size of 2 dB as given in table 5.4.2.2. This applies when the original (reference) timeslot power and the target timeslot power are between the Min power threshold for test and the Max power threshold for test derived from the Measured Maximum output power in Step F. The power step adjacent to the Min or Max power threshold for test should not be part of the 10 consecutive slots.
- m) During Step H, the difference in mean power between adjacent slots shall be within the prescribed range given in table 5.4.2.1 for a TPC_cmd of +1 and step size of 2 dB. This applies when the original (reference) timeslot power and the target timeslot power are between the Min power threshold for test and the Max power threshold for test derived from the Measured Maximum output power in Step H. For the power step adjacent to the Min or Max power threshold for test, the lower step size requirement does not apply.
- n) During Step H, the change in mean power over 10 consecutive slots shall be within the prescribed range for a TPC_cmd group of +1, and step size of 2 dB as given in table 5.4.2.2. This applies when the original (reference) timeslot power and the target timeslot power are between the Min power threshold for test and the Max power threshold for test derived from the Measured Maximum output power in Step H. The power step adjacent to the Min or Max power threshold for test should not be part of the 10 consecutive slots tested.

5.4.3 Minimum Output Power

5.4.3.1 Definition and applicability

The minimum controlled output power of the UE is when the power control setting is set to a minimum value. This is when both the inner loop and open loop power control indicate a minimum transmit output power is required.

The requirements and this test apply to all types of UTRA for the FDD UE.

5.4.3.2 Minimum Requirements

The minimum output power is defined as the mean power in one timeslot. The minimum transmit power shall be less than -50 dBm.

The normative reference for this requirement is TS 25.101 [1] clause 6.4.3.1.

5.4.3.3 Test purpose

To verify that the UE minimum transmit power is less than -50 dBm.

An excess minimum output power increases the interference to other channels, and decreases the system capacity.

5.4.3.4 Method of test

5.4.3.4.1 Initial conditions

Test environment: normal, TL/VL, TL/VH, TH/VL, TH/VH; see clauses G.2.1 and G.2.2.

Frequencies to be tested: low range, mid range, high range; see clause G.2.4.

- 1) Connect the SS to the UE antenna connector as shown in figure A.1.
- 2) A call is set up according to the Generic call setup procedure.
- 3) Enter the UE into loopback test mode and start the loopback test.

See TS 34.108 [3] and TS 34.109 [4] for details regarding generic call setup procedure and loopback test.

5.4.3.4.2 Procedure

- 1) Set and send continuously Down power control commands to the UE.
- 2) Measure the mean power of the UE.

5.4.3.5 Test requirements

The measured power, derived in step 2), shall be less than -49 dBm.

NOTE: If the above Test Requirement differs from the Minimum Requirement then the Test Tolerance applied for this test is non-zero. The Test Tolerance for this test is defined in clause F.2 and the explanation of how the Minimum Requirement has been relaxed by the Test Tolerance is given in clause F.4.

5.4.4 Out-of-synchronisation handling of output power

5.4.4.1 Definition and applicability

The UE shall monitor the DPCCH quality in order to detect a loss of the signal on Layer 1, as specified in TS 25.214 [5]. The thresholds Q_{out} and Q_{in} specify at what DPCCH quality levels the UE shall shut its power off and when it shall turn its power on respectively. The thresholds are not defined explicitly, but are defined by the conditions under which the UE shall shut its transmitter off and turn it on, as stated in this clause.

The DPCCH quality shall be monitored in the UE and compared to the thresholds Q_{out} and Q_{in} for the purpose of monitoring synchronization. The threshold Q_{out} should correspond to a level of DPCCH quality where no reliable detection of the TPC commands transmitted on the downlink DPCCH can be made. This can be at a TPC command error ratio level of e.g. 30%. The threshold Q_{in} should correspond to a level of DPCCH quality where detection of the TPC commands transmitted on the downlink DPCCH is significantly more reliable than at Q_{out} . This can be at a TPC command error ratio level of e.g. 20%.

The requirements and this test apply to all types of UTRA for the FDD UE.

5.4.4.2 Minimum Requirements

When the UE estimates the DPCCH quality over the last 160 ms period to be worse than a threshold Q_{out} , the UE shall shut its transmitter off within 40 ms. The UE shall not turn its transmitter on again until the DPCCH quality exceeds an acceptable level Q_{in} . When the UE estimates the DPCCH quality over the last 160 ms period to be better than a threshold Q_{in} , the UE shall again turn its transmitter on within 40 ms.

The UE transmitter shall be considered "off" if the transmitted power is below the level defined in subclause 6.5.1 (Transmit off power). Otherwise the transmitter shall be considered as "on".

The normative reference for this requirement is TS 25.101 [1] clause 6.4.4.1.

The quality levels at the thresholds Q_{out} and Q_{in} correspond to different signal levels depending on the downlink conditions DCH parameters. For the conditions in table 5.4.4.1, a signal with the quality at the level Q_{out} can be generated by a $DPCCH_Ec/I_{or}$ ratio of -25 dB, and a signal with Q_{in} by a $DPCCH_Ec/I_{or}$ ratio of -21 dB. The DL reference measurement channel (12.2) kbps specified in subclause C.3.1 and with static propagation conditions. The downlink physical channels, other than those specified in table 5.4.4.1, are as specified in table E.3.3 of Annex E.

Table 5.4.4.1: DCH parameters for test of Out-of-synch handling test case

Parameter	Value	Unit
\hat{I}_{or}/I_{oc}	-1	dB
I_{oc}	-60	dBm / 3,84 MHz
$\frac{DPDCH_E_c}{I_{or}}$	See Figure 5.4.4.1: Before point A -16,6 After point A Not defined See note in clause 5.4.4.3	dB
$\frac{DPCCH_E_c}{I_{or}}$	See table 5.4.4.2	dB
Information Data Rate	12,2	kbps

Table 5.4.4.2: Minimum Requirements for DPCCH_Ec/Ior levels

Clause from figure 5.4.4.1	DPCCH_Ec/Ior	Unit
Before A	-16,6	dB
A to B	-22,0	dB
B to D	-28,0	dB
D to E	-24,0	dB
After E	-18,0	dB

Figure 5.4.4.1 shows an example scenario where the $DPCCH_Ec/I_{or}$ ratio varies from a level where the DPCH is demodulated under normal conditions, down to a level below Q_{out} where the UE shall shut its power off and then back up to a level above Q_{in} where the UE shall turn the power back on.

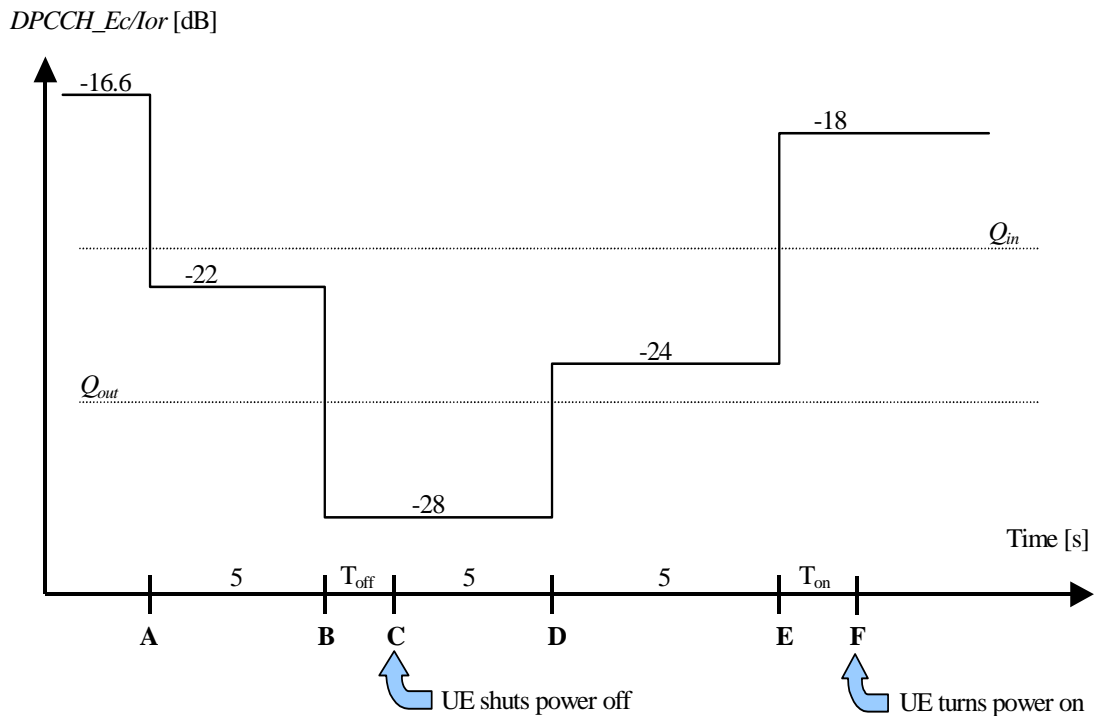

Figure 5.4.4.1: Test case for out-of-synch handling in the UE.

In this test case, the requirements for the UE are that:

1. The UE shall not shut its transmitter off before point B.
2. The UE shall shut its transmitter off before point C, which is $T_{off} = 200$ ms after point B.
3. The UE shall not turn its transmitter on between points C and E.
4. The UE shall turn its transmitter on before point F, which is $T_{on} = 200$ ms after point E.

The reference for this test case is TS 25.101 [1] clause 6.4.4.2.

5.4.4.3 Test purpose

To verify that the UE monitors the DPCCH quality and turns its transmitter on or off according to DPCCH level diagram specified in figure 5.4.4.1.

NOTE: $DPDCH_{Ec/I_{or}}$ after point A is not defined in table 5.4.4.1. However it is assumed that DPDCH and DPCCH power level are same on DL 12,2 kbps reference measurement channel for testing. (PO1, PO2, and PO3 are zero.)

5.4.4.4 Method of test

5.4.4.4.1 Initial conditions

Test environment: normal; see clauses G.2.1 and G.2.2.

Frequencies to be tested: mid range; see clause G.2.4.

- 1) Connect the SS to the UE antenna connector as shown in figure A.1.
- 2) A call is set up according to the Generic call setup procedure, with the following exception for information elements in System Information Block type 1 specified in TS 34.108 [3] subclause 6.1.0b.

Table 5.4.4.2A: System Information Block type 1 message

Information Element	Value/Remark
UE Timers and constants in connected mode - T313	15 seconds
- N313	200

- 3) DCH parameters are set up according to table 5.4.4.1 with DPCCH_Ec/Ior ratio level at -16,6 dB. The other RF parameters are set up according to clause E.3.3.
- 4) Enter the UE into loopback test mode and start the loopback test.

See TS 34.108 [3] and TS 34.109 [4] for details regarding generic call setup procedure and loopback test.

5.4.4.4.2 Procedure

- 1) The SS sends continuously Up power control commands to the UE until the UE transmitter power reach maximum level.
- 2) The SS controls the DPCCH_Ec/Ior ratio level according to clause 'A to B' as defined in table 5.4.4.3. The SS monitors the UE transmitted power for 5 seconds and verifies that the UE transmitter is not switched off during this time.
- 3) The SS controls the DPCCH_Ec/Ior ratio level according to clause 'B to D' as defined in table 5.4.4.3. The SS waits 200 ms and then verifies that the UE transmitter has been switched off.
- 4) The SS monitors the UE transmitted power for 5 seconds and verifies that the UE transmitter is not switched on during this time.
- 5) The SS controls the DPCCH_Ec/Ior ratio level according to clause 'D to E' as defined in table 5.4.4.3. The SS monitors the UE transmitted power for 5 s and verifies that the UE transmitter is not switched on during this time.
- 6) The SS controls the DPCCH_Ec/Ior ratio level according to clause 'After E' as defined in table 5.4.4.3. The SS waits 200 ms and then verifies that the UE transmitter has been switched on.

5.4.4.5 Test requirements

Table 5.4.4.3: Test Requirements for DPCCH_Ec/Ior levels

Clause from figure 5.4.4.1	DPCCH_Ec/Ior	Unit
Before A	-16,6	dB
A to B	-21,6	dB
B to D	-28,4	dB
D to E	-24,4	dB
After E	-17,6	dB

To pass the test, steps 1 through 6 of the procedure in clause 5.4.4.4.2 must be fulfilled.

The UE transmitter off criterion and its tolerances is defined in clause 5.5.1 (Transmit off power).

The UE transmitter on criterion and its tolerances is defined in clause 5.4.3 (Minimum Output Power). The UE transmitter is considered to be on if the UE transmitted power is higher than minimum output power.

NOTE: If the above Test Requirement differs from the Minimum Requirement then the Test Tolerance applied for this test is non-zero. The Test Tolerance for this test is defined in clause F.2 and the explanation of how the Test Requirement has been relaxed by the Test Tolerance is given in clause F.4.

5.5 Transmit ON/OFF Power

5.5.1 Transmit OFF Power

5.5.1.1 Definition and applicability

Transmit OFF power is defined as the RRC filtered mean power when the transmitter is off. The transmit OFF power state is when the UE does not transmit. During transmission gaps in UL compressed mode, the UE is not considered to be in the OFF state.

The requirements and this test apply to all types of UTRA for the FDD UE.

5.5.1.2 Minimum Requirements

The requirement for the transmit OFF power shall be less than -56 dBm.

The normative reference for this requirement is TS 25.101 [1] clause 6.5.1.1.

5.5.1.3 Test purpose

To verify that the UE transmit OFF power is less than -56 dBm.

An excess transmit OFF power increases the interference to other channels, and decreases the system capacity.

5.5.1.4 Method of test

This test is covered by clause 5.5.2 Transmit ON/OFF Time mask.

5.5.1.5 Test requirements

The measured RRC filtered mean power shall be less than -55 dBm.

NOTE: If the above Test Requirement differs from the Minimum Requirement then the Test Tolerance applied for this test is non-zero. The Test Tolerance for this test is defined in clause F.2 and the explanation of how the Minimum Requirement has been relaxed by the Test Tolerance is given in clause F.4.

5.5.2 Transmit ON/OFF Time mask

5.5.2.1 Definition and applicability

The time mask for transmit ON/OFF defines the ramping time allowed for the UE between transmit OFF power and transmit ON power. Possible ON/OFF scenarios are PRACH, CPCH or uplink compressed mode.

The requirements and this test apply to all types of UTRA for the FDD UE.

5.5.2.2 Minimum requirements

The transmit power levels versus time shall meet the mask specified in figure 5.5.1 for PRACH preambles, and the mask in figure 5.5.2 for all other cases. The off signal is defined as the RRC filtered mean power.

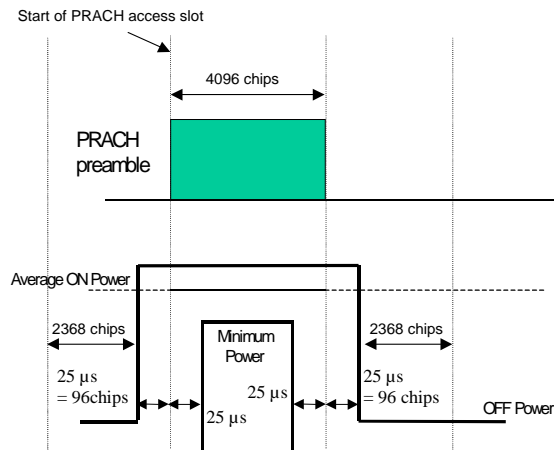

Figure 5.5.1: Transmit ON/OFF template for PRACH preambles

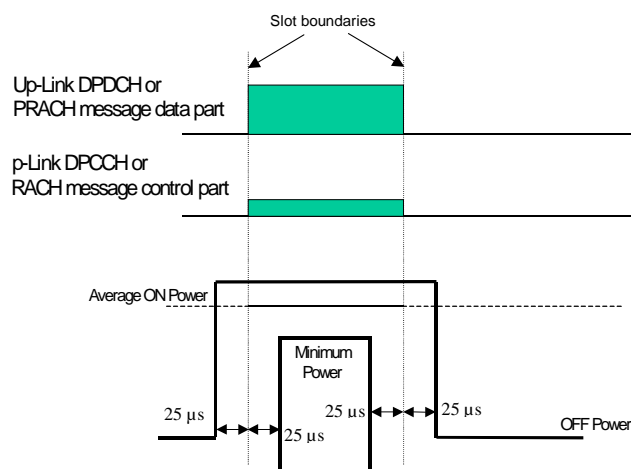

Figure 5.5.2: Transmit ON/OFF template for all other On/Off cases

OFF Power is defined in clause 5.5.1.2.

ON power is defined as the mean power. The specification depends on each possible case.

- First preamble of PRACH: Open loop accuracy (table 5.4.1.1).
- During preamble ramping of the RACH and between final RACH preamble and RACH message part: Accuracy depending on size of the required power difference (table 5.5.2.1).
- After transmission gaps in compressed mode: Accuracy as in table 5.7.1.
- Power step to Maximum Power: Maximum power accuracy (table 5.2.1).

Table 5.5.2.1: Transmitter power difference tolerance for RACH preamble ramping, and between final RACH preamble and RACH message part

Power difference size ΔP [dB]	Transmitter power difference tolerance [dB]
0	± 1
1	± 1
2	$\pm 1,5$
3	± 2
$4 \leq \Delta P \leq 10$	$\pm 2,5$
$11 \leq \Delta P \leq 15$	$\pm 3,5$
$16 \leq \Delta P \leq 20$	$\pm 4,5$
$21 \leq \Delta P$	$\pm 6,5$

The reference for this requirement is TS 25.101 [1] clause 6.5.2.1.

This is tested using PRACH operation.

5.5.2.3 Test purpose

To verify that the UE transmit ON/OFF power levels versus time meets the described mask shown in figure 5.5.1 and figure 5.5.2.

An excess error of transmit ON/OFF response increases the interference to other channels, or increases transmission errors in the up link own channel.

5.5.2.4 Method of test

5.5.2.4.1 Initial conditions

Test environment: normal, TL/VL, TL/VH, TH/VL, TH/VH; see clauses G.2.1 and G.2.2.

Frequencies to be tested: low range, mid range, high range; see clause G.2.4.

- 1) Connect the SS to the UE antenna connector as shown in figure A.1.
- 2) A call is set up according to the Generic call setup procedure, and \hat{I}_{or} are set up according to table 5.5.2.2. The relative power level of downlink physical channels to I_{or} are set up according to clause E.2.1.

The RACH procedure within the call setup is used for the test. The number of the available subchannels should be limited to one. This ensures that the preamble sequence is known to the SS. The preamble retransmission shall be at least 3. The power ramping step size shall be 1 dB. Note that the maximum number of preamble retransmissions is limited to 5 due to the fact that the commanded uplink power exceeds the allowed uplink power of more than 6 dB. The SS shall not send either an ACK or a NACK.

See TS 34.108 [3] for details regarding generic call setup procedure.

Table 5.5.2.2: Test parameters for Transmit ON/OFF Time mask (UE)

Parameter	Level / Status	Unit
\hat{I}_{or}	See table 5.5.2.3	dBm / 3,84 MHz

Table 5.5.2.3: Test parameters for Transmit ON/OFF Time mask (SS)

Parameter	Power Class 1	Power Class 2	Power Class 3	Power Class 4	Unit
\hat{I}_{or} (note 1)	-106,7	-106,7	-106,7	-106,7	dBm / 3,84 MHz
CPICH_RSCP (notes 1 and 2)	-110	-110	-110	-110	dBm
Primary CPICH DL TX power	+19	+19	+19	+19	dBm
Simulated path loss = Primary CPICH DL TX power – CPICH_RSCP	+129	+129	+129	+129	dB
UL interference	-86	-92	-95	-98	dBm
Constant Value	-10	-10	-10	-10	dB
Expected nominal UE TX power (note 3)	+33	+27	+24	+21	dBm
NOTE 1: The power level of S-CCPCH should be defined because S-CCPCH is transmitted during Preamble RACH transmission period. The power level of S-CCPCH is temporarily set to -10,3 dB relative to \hat{I}_{or} . However, it is necessary to check whether the above S-CCPCH level is enough to establish a connection with the reference measurement channels.					
NOTE 2: The purpose of this parameter is to calculate the Expected nominal UE TX power.					
NOTE 3: The Expected nominal UE TX power is calculated by using the equation in the clause 8.5.7 Open Loop Power Control of TS 25.331 [8].					

5.5.2.4.2 Procedure

- 1) Set the TX output level of the SS to obtain \hat{I}_{or} at the UE antenna connector and select the test parameters of table 5.5.2.3 according to the power class. \hat{I}_{or} shall be according to table 5.5.2.3 (-106,7 dBm / 3,84 MHz).
- 2) Measure the mean power (ON power) of the UE on the first RACH preamble or two consecutive RACH preambles. The measurements shall not include the transient periods. From the occurrence of the first RACH preamble the SS shall predict the following RACH preamble timing.
- 3) Measure the RRC filtered mean power (OFF power) in a 2368 chip time interval before a transient period of 25 μ s (96 chips) prior to a RACH preamble (ON power). Measure the RRC filtered mean power (OFF power) in a 2368 chip time interval after a transient period of 25 μ s (96 chips) after a RACH preamble (ON power).

5.5.2.5 Test requirements

The deviation with respect to the Expected nominal UE TX power (table 5.5.2.3), derived in step 2), shall not exceed the prescribed upper tolerance in table 5.2.2 (clause 5.2.5) and lower tolerance in table 5.4.1.1. (clause 5.4.1.2) for the first preamble, or shall meet the tolerance in table 5.5.2.1 for two consecutive preambles.

The measured RRC filtered mean power, derived in step 3), shall be less than -55 dBm. (clause 5.5.1.5).

5.6 Change of TFC

5.6.1 Definition and applicability

A change of TFC (Transport Format Combination) in uplink means that the power in the uplink varies according to the change in data rate. DTX, where the DPCH is turned off, is a special case of variable data, which is used to minimise the interference between UE(s) by reducing the UE transmit power when voice, user or control information is not present.

The requirements and this test apply to all types of UTRA for the FDD UE.

5.6.2 Minimum requirements

A change of output power is required when the TFC, and thereby the data rate, is changed. The ratio of the amplitude between the DPDCH codes and the DPCCH code will vary. The power step due to a change in TFC shall be calculated in the UE so that the power transmitted on the DPCCH shall follow the inner loop power control. The step in total transmitted power (DPCCH + DPDCH) shall then be rounded to the closest integer dB value. A power step exactly half-way between two integer values shall be rounded to the closest integer of greater magnitude. The accuracy of the power step, given the step size is specified in table 5.6.1. The power change due to a change in TFC is defined as the relative power difference between the mean power of the original (reference) timeslot and the mean power of the target timeslot, not including the transient duration. The transient duration is from 25 μ s before the slot boundary to 25 μ s after the slot boundary.

Table 5.6.1: Transmitter power step tolerance

Power control step size (Up or down) ΔP [dB]	Transmitter power step tolerance [dB]
0	$\pm 0,5$
1	$\pm 0,5$
2	$\pm 1,0$
3	$\pm 1,5$
$4 \leq \Delta P \leq 10$	$\pm 2,0$
$11 \leq \Delta P \leq 15$	$\pm 3,0$
$16 \leq \Delta P \leq 20$	$\pm 4,0$
$21 \leq \Delta P$	$\pm 6,0$

Clause C.2.1 defines the UL reference measurement channels (12,2 kbps) for TX test and the power ratio between DPCCH and DPDCH as $-5,46$ dB. Therefore, only one power control step size is selected as minimum requirement from table 5.6.1. The accuracy of the power step, given the step size is specified in table 5.6.2.

Table 5.6.2: Transmitter power step tolerance for test

Quantized amplitude ratios β_c and β_d	Power control step size (Up or down) ΔP [dB]	Transmitter power step tolerance [dB]
$\beta_c = 0,5333, \beta_d = 1,0$	7	± 2

The transmit power levels versus time shall meet the mask specified in figure 5.6.1.

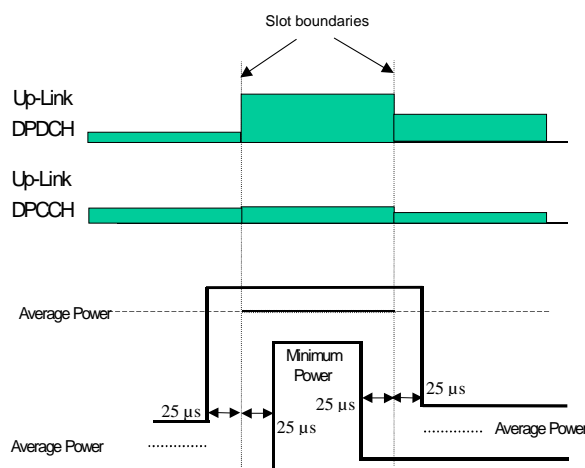

Figure 5.6.1: Transmit template during TFC change

The UL reference measurement channel (12,2 kbps) is a fixed rate channel. Therefore, DTX, where the DPDCH is turned off, is tested, as shown in figure 5.6.2.

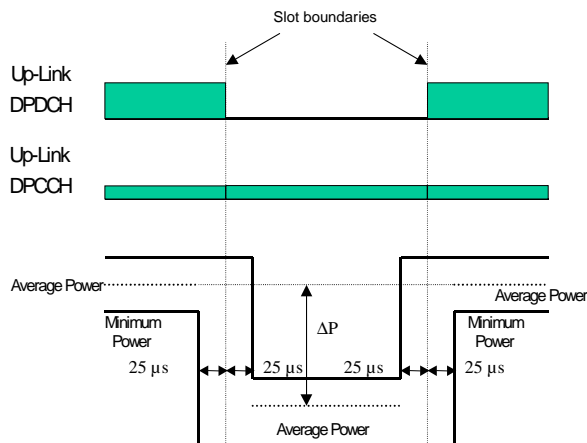

Figure 5.6.2: Transmit template during DTX

The reference for this requirement is TS 25.101 [1] clause 6.5.3.1.

5.6.3 Test purpose

To verify that the tolerance of power control step size does not exceed the described value shown in table 5.6.2.

To verify that the DTX ON/OFF power levels versus time meets the described mask shown in figure 5.6.2.

5.6.4 Method of test

5.6.4.1 Initial conditions

Test environment: normal; see clauses G.2.1 and G.2.2.

Frequencies to be tested: mid range; see clause G.2.4.

- 1) Connect the SS to the UE antenna connector as shown in figure A.1.
- 2) A call is set up according to the Generic call setup procedure. The Uplink DPCH Power Control Info shall specify the Power Control Algorithm as algorithm 2 for interpreting TPC commands.
- 3) Enter the UE into loopback test mode and start the loopback test.

See TS 34.108 [3] and TS 34.109 [4] for details regarding generic call setup procedure and loopback test.

5.6.4.2 Procedure

- 1) Set the attenuation in the downlink signal (\hat{I}_{Or}) to yield an open loop output power, measured at the UE antenna connector, of 0 dBm.
- 2) Send alternating "0" and "1" TPC commands in the downlink so as to satisfy the condition of obtaining $TPC_cmd = 0$.
- 3) Using the Tester, measure the mean power at the antenna connector of the UE in two cases, both DPDCH and DPCCH are ON and only DPCCH is ON. The measurements shall not include the transient periods.

5.6.5 Test requirements

The difference in mean power between DPDCH ON and OFF, derived in step 3), shall not exceed the prescribed range in table 5.6.2.

5.7 Power setting in uplink compressed mode

5.7.1 Definition and applicability

Compressed mode in uplink means that the power in uplink is changed.

The requirements and this test apply to all types of UTRA for the FDD UE.

5.7.2 Minimum requirements

A change of output power is required during uplink compressed frames since the transmission of data is performed in a shorter interval. The ratio of the amplitude between the DPDCH codes and the DPCCH code will also vary. The power step due to compressed mode shall be calculated in the UE so that the energy transmitted on the pilot bits during each transmitted slot shall follow the inner loop power control.

Thereby, the power during compressed mode, and immediately afterwards, shall be such that the mean power of the DPCCH follows the steps due to inner loop power control combined with additional steps of $10\log_{10}(N_{\text{pilot,prev}} / N_{\text{pilot,curr}})$ dB where $N_{\text{pilot,prev}}$ is the number of pilot bits in the previously transmitted slot, and $N_{\text{pilot,curr}}$ is the current number of pilot bits per slot.

The resulting step in total transmitted power (DPCCH + DPDCH) shall then be rounded to the closest integer dB value. A power step exactly half-way between two integer values shall be rounded to the closest integer of greatest magnitude. The accuracy of the power step, given the step size, is specified in table 5.6.1 in clause 5.6.2. The power step is defined as the relative power difference between the mean power of the original (reference) timeslot and the mean power of the target timeslot, when neither the original timeslot nor the reference timeslot are in a transmission gap. The transient duration is not included, and is from 25 μ s before the slot boundary to 25 μ s after the slot boundary.

In addition to any power change due to the ratio $N_{\text{pilot,prev}} / N_{\text{pilot,curr}}$, the mean power of the DPCCH in the first slot after a compressed mode transmission gap shall differ from the mean power of the DPCCH in the last slot before the transmission gap by an amount Δ_{RESUME} , where Δ_{RESUME} is calculated as described in clause 5.1.2.3 of TS 25.214 [5].

The resulting difference in the total transmitted power (DPCCH + DPDCH) shall then be rounded to the closest integer dB value. A power difference exactly half-way between two integer values shall be rounded to the closest integer of greatest magnitude. The accuracy of the resulting difference in the total transmitted power (DPCCH + DPDCH) after a transmission gap of up to 14 slots shall be as specified in table 5.7.1.

Table 5.7.1: Transmitter power difference tolerance after a transmission gap of up to 14 slots

Power difference (Up or down) ΔP [dB]	Transmitter power step tolerance after a transmission gap [dB]
$\Delta P \leq 2$	+/- 3
3	+/- 3
$4 \leq \Delta P \leq 10$	+/- 3.5
$11 \leq \Delta P \leq 15$	+/- 4
$16 \leq \Delta P \leq 20$	+/- 4.5
$21 \leq \Delta P$	+/- 6.5

The power difference is defined as the difference between the mean power of the original (reference) timeslot before the transmission gap and the mean power of the target timeslot after the transmission gap, not including the transient durations. The transient durations at the start and end of the transmission gaps are each from 25 μ s before the slot boundary to 25 μ s after the slot boundary.

The transmit power levels versus time shall meet the mask specified in figure 5.7.1.

The reference for this requirement is TS 25.101 [1] clause 6.5.4.1.

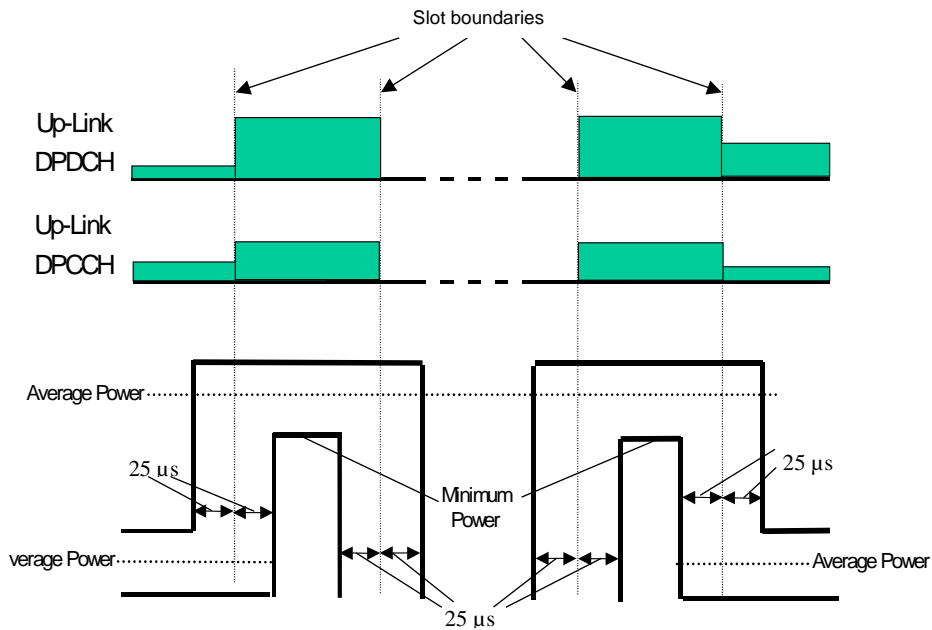

Figure 5.7.1: Transmit template during Compressed mode

For RPL (Recovery Period Length) slots after the transmission gap, where RPL is the minimum out of the transmission gap length and 7 slots, the UE shall use the power control algorithm and step size specified by the signalled Recovery Period Power Control Mode (RPP), as detailed in TS 25.214 [5] clause 5.1.2.3.

When nominal 3 dB power control steps are used in the recovery period, the transmitter mean power steps due to inner loop power control shall be within the range shown in table 5.7.2, and the transmitter aggregate mean power step due to inner loop power control shall be within the range shown in table 5.7.3, excluding any other power changes due, for example, to changes in spreading factor or number of pilot bits.

Table 5.7.2: Transmitter power control range for 3dB step size

TPC_cmd	Transmitter power control range for 3dB step size	
	Lower	Upper
+1	+1,5 dB	+4,5 dB
0	-0,5 dB	+0,5 dB
-1	-1,5 dB	-4,5 dB

Table 5.7.3: Transmitter aggregate power control range for 3dB step size

TPC_cmd group	Transmitter power control range after 7 equal TPC_cmd groups	
	Lower	Upper
+1	+16 dB	+26 dB
0	-1 dB	+1 dB
-1	-16 dB	-26 dB

The reference for this requirement is TS 25.101 [1] clause 6.4.2.1.1.

5.7.3 Test purpose

To verify that the changes in uplink transmit power in compressed mode are within the prescribed tolerances.

Excess error in transmit power setting in compressed mode increases the interference to other channels, or increases transmission errors in the uplink.

5.7.4 Method of test

5.7.4.1 Initial conditions

Test environment: normal; see clauses G.2.1 and G.2.2.

Frequencies to be tested: mid range; see clause G.2.4.

- 1) Connect the SS to the UE antenna connector as shown in figure A.1.
- 2) A call is set up according to the Generic call setup procedure. The 12,2 kbps UL reference measurement channel is used, with gain factors $\beta_c = 0,5333$ and $\beta_d = 1,0$ in non-compressed frames. Slot formats 0 and 0B are used on the uplink DPCCCH.
- 3) Enter the UE into loopback test mode and start the loopback test.

See TS 34.108 [3] and TS 34.109 [4] for details regarding generic call setup procedure and loopback test.

5.7.4.2 Procedure

NOTE: CFNs are given in this procedure for reference as examples only. A fixed offset may be applied to the CFNs.

- 1) Before proceeding with step (3) below, set the output power of the UE, measured at the UE antenna connector, to be in the range -36 ± 9 dBm. This may be achieved by setting the downlink signal (\hat{I}_{or}) to yield an appropriate open loop output power and/or by generating suitable downlink TPC commands from the SS.
- 2) Transmit the PHYSICAL CHANNEL RECONFIGURATION message to set the uplink power control parameters to use Algorithm 1 and a step size of 2 dB, and to set the compressed mode parameters shown in table 5.7.5. The contents of the message are specified in table 5.7.9. This set of compressed mode parameters defines the compressed mode pattern which is used to test the implementation of:
 - a) in steps (3) and (4), upward 3 dB output power steps and the implementation of a downward power change when resuming transmission after a compressed mode gap, and
 - b) in steps (7) and (8), downward 3dB output power steps and the implementation of an upward power change when resuming transmission after a compressed mode gap.

Table 5.7.5: Parameters for pattern A for compressed mode test

Parameter	Meaning	Value
TGPRC	Number of transmission gap patterns within the Transmission Gap Pattern Sequence	1
TGCFN	Connection Frame Number of the first frame of the first pattern within the Transmission Gap Pattern Sequence	0
TGSN	Slot number of the first transmission gap slot within the TGCFN	2
TGL1	Length of first transmission gap within the transmission gap pattern	7 slots
TGL2	Length of second transmission gap within the transmission gap pattern	7 slots
TGD	Duration between the starting slots of two consecutive transmission gaps within a transmission gap pattern	15 slots
TGPL1	Duration of transmission gap pattern 1	3 frames
TGPL2	Duration of transmission gap pattern 2	Omit
RPP	Recovery Period Power Control Mode	Mode 1
ITP	Initial Transmit Power Mode	Mode 1
UL/DL Mode	Defines whether only DL, only UL, or combined UL/DL compressed mode is used	UL/DL
Downlink Compressed Mode Method	Method for generating downlink compressed mode gap	SF/2
Uplink Compressed Mode Method	Method for generating uplink compressed mode gap	SF/2
Scrambling code change	Indicates whether the alternative scrambling code is used	No code change
Downlink frame type	Downlink compressed frame structure	A
DeltaSIR	Delta in DL SIR target value to be set in the UE during compressed frames	0
DeltaSIRafter	Delta in DL SIR target value to be set in the UE one frame after the compressed frames	0

The resulting compressed mode pattern is shown in figure 5.7.2.

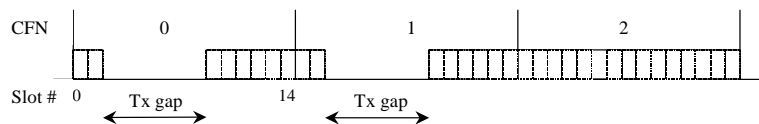

Figure 5.7.2: Pattern A for compressed mode test

- 3) After the PHYSICAL CHANNEL RECONFIGURATION COMPLETE message from the UE is received, transmit TPC commands on the downlink as shown in table 5.7.6.

Table 5.7.6: TPC commands transmitted in downlink

CFN	TPC commands in downlink
0	0 1 - - - - - 1 1 1 1 1 1
1	1 1 - - - - - 1 0 1 0 1 0
2	1 0 1 0 1 0 1 0 1 0 1 0 1

- 4) Measure the mean power in the following slots, not including the 25 μs transient periods at the start and end of each slot:

CFN 0: Slots # 9,10,11,12,13,14
 CFN 1: Slots # 0,1,9

- 5) Re-start the test. Before proceeding with step (7) below, set the output power of the UE, measured at the UE antenna connector, to be in the range 2 ± 9 dBm. This may be achieved by setting the downlink signal (Îor) to

yield an appropriate open loop output power and/or by generating suitable downlink TPC commands from the SS.

- 6) Repeat step (2) above, with the exception that TGCFN = 3 in table 5.7.5 and table 5.7.9.
- 7) After the PHYSICAL CHANNEL RECONFIGURATION COMPLETE message from the UE is received, transmit TPC commands on the downlink as shown in table 5.7.7.

Table 5.7.7: TPC commands transmitted in downlink

CFN	TPC commands in downlink
3	0 1 - - - - - 0 0 0 0 0
4	0 0 - - - - - 0 1 0 1 0 1
5	0 1 0 1 0 1 0 1 0 1 0 1 0

- 8) Measure the mean power in the following slots, not including the 25 μ s transient periods at the start and end of each slot:
 - CFN 3: Slots # 9,10,11,12,13,14
 - CFN 4: Slots # 0,1,9
- 9) Re-start the test. Before proceeding with step (11) below, set the output power of the UE, measured at the UE antenna connector, to be in the range -10 ± 9 dBm. This may be achieved by setting the downlink signal (\hat{I} or) to yield an appropriate open loop output power and/or by generating suitable downlink TPC commands from the SS.
- 10) Transmit the PHYSICAL CHANNEL RECONFIGURATION message to set the uplink power control parameters to use Algorithm 1 and a step size of 1 dB, and to set the compressed mode parameters shown in table 5.7.8. The contents of the message are specified in table 5.7.10. This set of compressed mode parameters defines the compressed mode pattern which is used to test the implementation of power steps at the start and end of compressed frames, and the implementation of a zero power change when resuming transmission after a compressed mode gap.

Table 5.7.8: Parameters for pattern B for compressed mode test

Parameter	Meaning	Value
TGPRC	Number of transmission gap patterns within the Transmission Gap Pattern Sequence	1
TGCFN	Connection Frame Number of the first frame of the first pattern within the Transmission Gap Pattern Sequence	7
TGSN	Slot number of the first transmission gap slot within the TGCFN	8
TGL1	Length of first transmission gap within the transmission gap pattern	14 slots
TGL2	Length of second transmission gap within the transmission gap pattern	omit
TGD	Duration between the starting slots of two consecutive transmission gaps within a transmission gap pattern	0
TGPL1	Duration of transmission gap pattern 1	4 frames
TGPL2	Duration of transmission gap pattern 2	Omit
RPP	Recovery Period Power Control Mode	Mode 0
ITP	Initial Transmit Power Mode	Mode 0
UL/DL Mode	Defines whether only DL, only UL, or combined UL/DL compressed mode is used	UL/DL
Downlink Compressed Mode Method	Method for generating downlink compressed mode gap	SF/2
Uplink Compressed Mode Method	Method for generating uplink compressed mode gap	SF/2
Scrambling code change	Indicates whether the alternative scrambling code is used	No code change
Downlink frame type	Downlink compressed frame structure	A
DeltaSIR	Delta in DL SIR target value to be set in the UE during compressed frames	0
DeltaSIRafter	Delta in DL SIR target value to be set in the UE one frame after the compressed frames	0

The resulting compressed mode pattern is shown in figure 5.7.3.

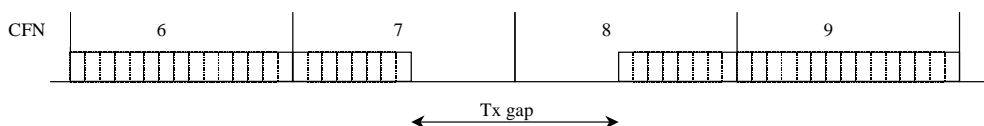

Figure 5.7.3: Pattern B for compressed mode test

- 11) After the PHYSICAL CHANNEL RECONFIGURATION COMPLETE message from the UE is received, transmit TPC commands on the downlink as shown in table 5.7.8.

Table 5.7.8: TPC commands transmitted in downlink

CFN	TPC commands in downlink
6	0 0 0 0 0 0 0 0 0 0 0 1 1 1
7	1 1 1 1 1 1 1 1 - - - - -
8	- - - - - 0 0 0 0 0 0 0
9	0 0 1 1 1 1 1 1 1 1 1 1 1 1

- 12) Measure the mean power in the following slots, not including the 25 μs transient periods at the start and end of each slot:

- CFN 6: Slot # 14
- CFN 7: Slots # 0 and 7
- CFN 8: Slots # 7 and 14
- CFN 9: Slot # 0

Table 5.7.9: PHYSICAL CHANNEL RECONFIGURATION message (step 2)

Information Element	Value/Remark
Message Type	
UE Information Elements	
-RRC transaction identifier	0
-Integrity check info	Not Present
-Integrity protection mode info	Not Present
-Ciphering mode info	Not Present
-Activation time	Not Present
-New U-RNTI	Not Present
-New C-RNTI	Not Present
-RRC State Indicator	CELL_DCH
-UTRAN DRX cycle length coefficient	Not Present
CN Information Elements	
-CN Information info	Not Present
UTRAN mobility information elements	
-URA identity	Not Present
RB information elements	
-Downlink counter synchronisation info	Not Present
PhyCH information elements	
-Frequency info	Not Present
Uplink radio resources	
-Maximum allowed UL TX power	Not Present
-CHOICE channel requirement	Uplink DPCH info
-Uplink DPCH power control info	
-CHOICE mode	FDD
-DPCCH Power offset	-6dB
-PC Preamble	1 frame
-SRB delay	7 frames
-Power Control Algorithm	Algorithm 1
-TPC step size	2dB
-CHOICE mode	FDD
-Scrambling code type	Long
-Scrambling code number	0
-Number of DPDCH	1
-spreading factor	64
-TFCI existence	TRUE
-Number of FBI bits	Not Present(0)
-Puncturing Limit	1
Downlink radio resources	
-CHOICE mode	FDD
-Downlink PDSCH information	Not Present
-Downlink information common for all radio links	
-Downlink DPCH info common for all RL	Not Present
-CHOICE mode	FDD
-DPCH compressed mode info	
-Transmission gap pattern sequence	
-TGPSI	1
-TGPS Status Flag	Activate
-TGCFN	0
-Transmission gap pattern sequence	
configuration parameters	
-TGMP	FDD measurement
-TGPRC	1
-TGSN	2
-TGL1	7
-TGL2	7
-TGD	15
-TGPL1	3
-TGPL2	Not Present
-RPP	Mode 1
-ITP	Mode 1
-CHOICE UL/DL mode	UL and DL
-Downlink compressed mode method	SF/2
-Uplink compressed mode method	SF/2
-Downlink frame type	A

-DeltaSIR1	0
-DeltaSIRafter1	0
-DeltaSIR2	Not Present
-DeltaSIRafter2	Not Present
-N Identify abort	Not Present
-T Reconfirm abort	Not Present
-TX Diversity Mode	Not Present
-SSDT information	Not Present
-Default DPCH Offset Value	Not Present
-Downlink information per radio link list	
- Downlink information for each radio link	
-Choice mode	FDD
-Primary CPICH info	
-Primary scrambling code	100
-PDSCH with SHO DCH Info	Not Present
-PDSCH code mapping	Not Present
-Downlink DPCH info for each RL	
-CHOICE mode	FDD
-Primary CPICH usage for channel estimation	Primary CPICH may be used
-DPCH frame offset	Set to value Default DPCH Offset Value (as currently stored in SS) mod 38400
-Secondary CPICH info	Not Present
-DL channelisation code	
-Secondary scrambling code	Not Present
-Spreading factor	128
-Code number	0
-Scrambling code change	No code change
-TPC combination index	0
-SSDT Cell Identity	Not Present
-Closed loop timing adjustment mode	Not Present
-SCCPCH Information for FACH	Not Present

Table 5.7.10: PHYSICAL CHANNEL RECONFIGURATION message (step 10)

Information Element	Value/Remark
Message Type	
UE Information Elements -RRC transaction identifier -Integrity check info -Integrity protection mode info -Ciphering mode info -Activation time -New U-RNTI -New C-RNTI -RRC State Indicator -UTRAN DRX cycle length coefficient	0 Not Present Not Present Not Present Not Present Not Present Not Present CELL_DCH Not Present
CN Information Elements -CN Information info	Not Present
UTRAN mobility information elements -URA identity	Not Present
RB information elements -Downlink counter synchronisation info	Not Present
PhyCH information elements -Frequency info	Not Present
Uplink radio resources -Maximum allowed UL TX power -CHOICE channel requirement -Uplink DPCH power control info -CHOICE mode -DPCCH Power offset -PC Preamble -SRB delay -Power Control Algorithm -TPC step size -CHOICE mode -Scrambling code type -Scrambling code number -Number of DPDCH -spreading factor -TFCI existence -Number of FBI bits -Puncturing Limit	Not Present Uplink DPCH info FDD -6dB 1 frame 7 frames Algorithm 1 1dB FDD Long 0 1 64 TRUE Not Present(0) 1
Downlink radio resources -CHOICE mode -Downlink PDSCH information -Downlink information common for all radio links -Downlink DPCH info common for all RL -CHOICE mode -DPCH compressed mode info -Transmission gap pattern sequence -TGPSI -TGPS Status Flag -TGCFN -Transmission gap pattern sequence configuration parameters -TGMP -TGPRC -TGSN -TGL1 -TGL2 -TGD -TGPL1 -TGPL2 -RPP -ITP -CHOICE UL/DL mode -Downlink compressed mode method -Uplink compressed mode method -Downlink frame type	FDD Not Present Not Present FDD 1 Activate 7 FDD measurement 1 8 14 Not Present 0 4 Not Present Mode 0 Mode 0 UL and DL SF/2 SF/2 A

-DeltaSIR1	0
-DeltaSIRafter1	0
-DeltaSIR2	Not Present
-DeltaSIRafter2	Not Present
-N Identify abort	Not Present
-T Reconfirm abort	Not Present
-TX Diversity Mode	Not Present
-SSDT information	Not Present
-Default DPCH Offset Value	Not Present
-Downlink information per radio link list	
- Downlink information for each radio link	
-Choice mode	FDD
-Primary CPICH info	
-Primary scrambling code	100
-PDSCH with SHO DCH Info	Not Present
-PDSCH code mapping	Not Present
-Downlink DPCH info for each RL	
-CHOICE mode	FDD
-Primary CPICH usage for channel estimation	Primary CPICH may be used
-DPCH frame offset	Set to value Default DPCH Offset Value (as currently stored in SS) mod 38400
-Secondary CPICH info	Not Present
-DL channelisation code	
-Secondary scrambling code	Not Present
-Spreading factor	128
-Code number	0
-Scrambling code change	No code change
-TPC combination index	0
-SSDT Cell Identity	Not Present
-Closed loop timing adjustment mode	Not Present
-SCCPCH Information for FACH	Not Present

5.7.5 Test requirements

For ease of reference, the following uplink output power measurements are defined in figure 5.7.4. In this figure:

- P_g is the RRC filtered mean power in an uplink transmission gap, excluding the 25 μ s transient periods.
- P_a is the mean power in the last slot before a compressed frame (or pair of compressed frames), excluding the 25 μ s transient periods.
- P_b is the mean power in the first slot of a compressed frame, excluding the 25 μ s transient periods.
- P_c is the mean power in the last slot before a transmission gap, excluding the 25 μ s transient periods.
- P_d is the mean power in the first slot after a transmission gap, excluding the 25 μ s transient periods.
- P_e is the mean power in the last slot of a compressed frame, excluding the 25 μ s transient periods.
- P_f is the mean power in the first slot after a compressed frame (or pair of compressed frames), excluding the 25 μ s transient periods.

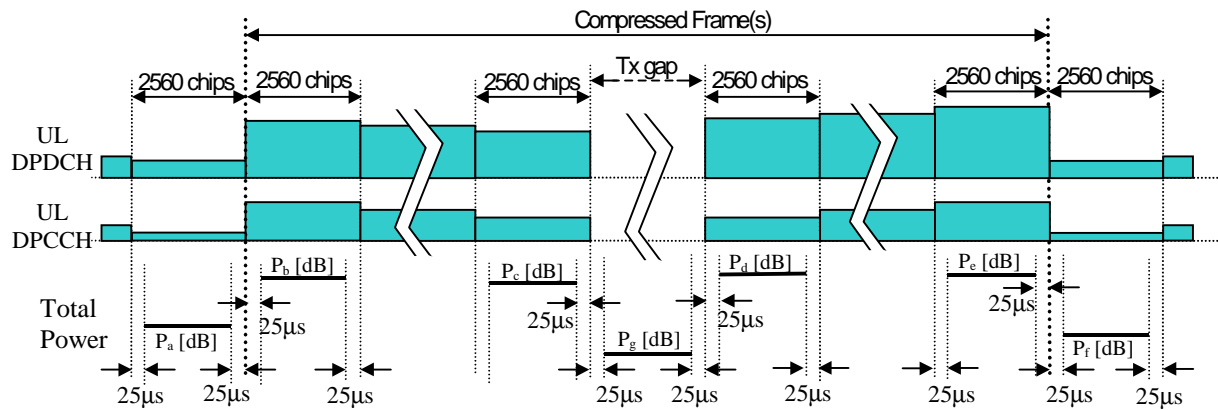

Figure 5.7.4: Uplink transmit power in uplink compressed mode

1. At the boundary between CFN 6 and CFN 7, $P_b - P_a$ shall be within the range $+4 \pm 2$ dB.
2. In slot #9 of CFN 1, the power difference $P_d - P_c$ from the power in slot #1 of CFN 1 shall be within the range -11 ± 4 dB.
3. In slot #9 of CFN 4, the power difference $P_d - P_c$ from the power in slot #1 of CFN 4 shall be within the range $+11 \pm 4$ dB.
4. In slot #7 of CFN 8, the power difference $P_d - P_c$ from the power in slot #7 of CFN 7 shall be within the range 0 ± 3 dB.
5. (void)
6. At the boundary between CFN 8 and CFN 9, $P_f - P_e$ shall be within the range -4 ± 2 dB.
7. In the slots between slot #10 of CFN 0 and slot #1 of CFN 1 inclusive, the change in mean power from the previous slot shall be within the range given in table 5.7.2 for $TPC_cmd = +1$.
8. The aggregate change in mean power from slot #9 of CFN 0 to slot #1 of CFN 1 shall be within the range given in table 5.7.3 for $TPC_cmd = +1$.
9. In the slots between slot #10 of CFN 3 and slot #1 of CFN 4 inclusive, the change in mean power from the previous slot shall be within the range given in table 5.7.2 for $TPC_cmd = -1$.
10. The aggregate change in mean power from slot #9 of CFN 3 to slot #1 of CFN 4 shall be within the range given in table 5.7.3 for $TPC_cmd = -1$.

5.8 Occupied Bandwidth (OBW)

5.8.1 Definition and applicability

Occupied bandwidth is a measure of the bandwidth containing 99 % of the total integrated power of the transmitted spectrum, centred on the assigned channel frequency.

The requirements and this test apply to all types of UTRA for the FDD UE.

5.8.2 Minimum Requirements

The occupied channel bandwidth shall be less than 5 MHz based on a chip rate of 3,84 Mcps.

The normative reference for this requirement is TS 25.101 [1] clause 6.6.1.

5.8.3 Test purpose

To verify that the UE occupied channel bandwidth is less than 5 MHz based on a chip rate of 3,84 Mcps.

Excess occupied channel bandwidth increases the interference to other channels or to other systems.

5.8.4 Method of test

5.8.4.1 Initial conditions

Test environment: normal; see clauses G.2.1 and G.2.2.

Frequencies to be tested: low range, mid range, high range; see clause G.2.4.

- 1) Connect the SS to the UE antenna connector as shown in figure A.1.
- 2) A call is set up according to the Generic call setup procedure.
- 3) Enter the UE into loopback test mode and start the loopback test.

See TS 34.108 [3] and TS 34.109 [4] for details regarding generic call setup procedure and loopback test.

5.8.4.2 Procedure

- 1) Set and send continuously Up power control commands to the UE until the UE output power shall be maximum level.
- 2) Measure the power spectrum distribution within two times or more range over the requirement for Occupied Bandwidth specification centring on the current carrier frequency with 30 kHz or less RBW. The characteristic of the filter shall be approximately Gaussian (typical spectrum analyzer filter).
- 3) Calculate the total power within the range of all frequencies measured in '2)' and save this value as "Total Power".
- 4) Sum up the power upward from the lower boundary of the measured frequency range in '2)' and seek the limit frequency point by which this sum becomes 0,5 % of "Total Power" and save this point as "Lower Frequency".
- 5) Sum up the power downward from the upper boundary of the measured frequency range in '2)' and seek the limit frequency point by which this sum becomes 0,5 % of "Total Power" and save this point as "Upper Frequency".
- 6) Calculate the difference ("Upper Frequency" – "Lower Frequency" = "Occupied Bandwidth") between two limit frequencies obtained in '4)' and '5)'.

5.8.5 Test Requirements

The measured Occupied Bandwidth, derived in step 6), shall not exceed 5 MHz.

NOTE: If the above Test Requirement differs from the Minimum Requirement then the Test Tolerance applied for this test is non-zero. The Test Tolerance for this test is defined in clause F.2 and the explanation of how the Minimum Requirement has been relaxed by the Test Tolerance is given in clause F.4.

5.9 Spectrum emission mask

5.9.1 Definition and applicability

The spectrum emission mask of the UE applies to frequencies, which are between 2,5 MHz and 12,5 MHz away from the UE centre carrier frequency. The out of channel emission is specified relative to the RRC filtered mean power of the UE carrier.

The requirements and this test apply to all types of UTRA for the FDD UE.

5.9.2 Minimum Requirements

The power of any UE emission shall not exceed the levels specified in table 5.9.1.

Table 5.9.1: Spectrum Emission Mask Requirement

Δf in MHz (note 1)	Minimum requirement Band I, II, III	Additional requirements Band II	Measurement bandwidth
2,5 to 3,5	$\left\{ -35 - 15 \cdot \left(\frac{\Delta f}{\text{MHz}} - 2.5 \right) \right\} \text{dBc}$	-15 dBm	30 kHz (note 2)
3,5 to 7,5	$\left\{ -35 - 1 \cdot \left(\frac{\Delta f}{\text{MHz}} - 3.5 \right) \right\} \text{dBc}$	-13 dBm	1 MHz (note 3)
7,5 to 8,5	$\left\{ -39 - 10 \cdot \left(\frac{\Delta f}{\text{MHz}} - 7.5 \right) \right\} \text{dBc}$	-13 dBm	1 MHz (note 3)
8,5 to 12,5	-49 dBc	-13 dBm	1 MHz (note 3)
NOTE 1: Δf is the separation between the carrier frequency and the centre of the measuring filter. NOTE 2: The first and last measurement position with a 30 kHz filter is at Δf equals to 2,515 MHz and 3,485 MHz. NOTE 3: The first and last measurement position with a 1 MHz filter is at Δf equals to 4 MHz and 12 MHz. As a general rule, the resolution bandwidth of the measuring equipment should be equal to the measurement bandwidth. To improve measurement accuracy, sensitivity and efficiency, the resolution bandwidth can be different from the measurement bandwidth. When the resolution bandwidth is smaller than the measurement bandwidth, the result should be integrated over the measurement bandwidth in order to obtain the equivalent noise bandwidth of the measurement bandwidth.			
The lower limit shall be -50 dBm/3,84 MHz or which ever is higher.			

The normative reference for this requirement is TS 25.101 [23] clause 6.6.2.1.1.

5.9.3 Test purpose

To verify that the power of UE emission does not exceed the prescribed limits shown in table 5.9.1.

Excess emission increases the interference to other channels or to other systems.

5.9.4 Method of test

5.9.4.1 Initial conditions

Test environment: normal; see clauses G.2.1 and G.2.2.

Frequencies to be tested: low range, mid range, high range; see clause G.2.4.

- 1) Connect the SS to the UE antenna connector as shown in figure A.1.
- 2) A call is set up according to the Generic call setup procedure.
- 3) Enter the UE into loopback test mode and start the loopback test.

See TS 34.108 [3] and TS 34.109 [4] for details regarding generic call setup procedure and loopback test.

5.9.4.2 Procedure

- 1) Set and send continuously Up power control commands to the UE until the UE output power shall be maximum level.
- 2) Measure the power of the transmitted signal with a measurement filter of bandwidths according to table 5.9.2. Measurements with an offset from the carrier centre frequency between 2,515 MHz and 3,485 MHz shall use a

30 kHz measurement filter. Measurements with an offset from the carrier centre frequency between 4 MHz and 12 MHz shall use 1 MHz measurement bandwidth and the result may be calculated by integrating multiple 50 kHz or narrower filter measurements. The characteristic of the filter shall be approximately Gaussian (typical spectrum analyzer filter). The centre frequency of the filter shall be stepped in contiguous steps according to table 5.9.2. The measured power shall be recorded for each step.

- 3) Measure the RRC filtered mean power centered on the assigned channel frequency.
- 4) Calculate the ratio of the power 2) with respect to 3) in dBc.

5.9.5 Test requirements

The result of clause 5.9.4.2 step 4) shall fulfil the requirements of table 5.9.2.

Table 5.9.2: Spectrum Emission Mask Requirement

Δf in MHz (note 1)	Minimum requirement Band I, II, III	Additional requirements Band II	Measurement bandwidth
2,5 to 3,5	$\left\{ -33.5 - 15 \cdot \left(\frac{\Delta f}{\text{MHz}} - 2.5 \right) \right\} \text{dBc}$	-15 dBm	30 kHz (note 2)
3,5 to 7,5	$\left\{ -33.5 - 1 \cdot \left(\frac{\Delta f}{\text{MHz}} - 3.5 \right) \right\} \text{dBc}$	-13 dBm	1 MHz (note 3)
7,5 to 8,5	$\left\{ -37.5 - 10 \cdot \left(\frac{\Delta f}{\text{MHz}} - 7.5 \right) \right\} \text{dBc}$	-13 dBm	1 MHz (note 3)
8,5 to 12,5	-47,5 dBc	-13 dBm	1 MHz (note 3)
NOTE 1: Δf is the separation between the carrier frequency and the centre of the measuring filter. NOTE 2: The first and last measurement position with a 30 kHz filter is at Δf equals to 2,515 MHz and 3,485 MHz. NOTE 3: The first and last measurement position with a 1 MHz filter is at Δf equals to 4 MHz and 12 MHz. As a general rule, the resolution bandwidth of the measuring equipment should be equal to the measurement bandwidth. To improve measurement accuracy, sensitivity and efficiency, the resolution bandwidth can be different from the measurement bandwidth. When the resolution bandwidth is smaller than the measurement bandwidth, the result should be integrated over the measurement bandwidth in order to obtain the equivalent noise bandwidth of the measurement bandwidth.			
The lower limit shall be -48,5 dBm/3,84 MHz or which ever is higher.			

NOTE: If the above Test Requirement differs from the Minimum Requirement then the Test Tolerance applied for this test is non-zero. The Test Tolerance for this test is defined in clause F.2 and the explanation of how the Minimum Requirement has been relaxed by the Test Tolerance is given in clause F.4.

5.10 Adjacent Channel Leakage Power Ratio (ACLR)

5.10.1 Definition and applicability

ACLR is the ratio of the RRC filtered mean power centred on the assigned channel frequency to the RRC filtered mean power centred on an adjacent channel frequency.

The requirements and this test apply to all types of UTRA for the FDD UE.

5.10.2 Minimum Requirements

If the adjacent channel RRC filtered mean power is greater than -50dBm then the ACLR shall be higher than the value specified in table 5.10.1.

Table 5.10.1: UE ACLR

Power Class	UE channel	ACLR limit
3	+5 MHz or -5 MHz	33 dB
3	+10 MHz or -10 MHz	43 dB
4	+5 MHz or -5 MHz	33 dB
4	+10 MHz or -10 MHz	43 dB

NOTE 1: The requirement shall still be met in the presence of switching transients.

NOTE 2: The ACLR requirements reflect what can be achieved with present state of the art technology.

NOTE 3: Requirement on the UE shall be reconsidered when the state of the art technology progresses.

The normative reference for this requirement is TS 25.101 [1] clause 6.6.2.2.1.

5.10.3 Test purpose

To verify that the UE ACLR does not exceed prescribed limit shown in table 5.10.1.

Excess ACLR increases the interference to other channels or to other systems.

5.10.4 Method of test

5.10.4.1 Initial conditions

Test environment: normal, TL/VL, TL/VH, TH/VL, TH/VH; see clauses G.2.1 and G.2.2.

Frequencies to be tested: low range, mid range, high range; see clause G.2.4.

- 1) Connect the SS to the UE antenna connector as shown in figure A.1.
- 2) A call is set up according to the Generic call setup procedure.
- 3) Enter the UE into loopback test mode and start the loopback test.

See TS 34.108 [3] and TS 34.109 [4] for details regarding generic call setup procedure and loopback test.

5.10.4.2 Procedure

- 1) Set and send continuously Up power control commands to the UE until the UE output power shall be maximum level.
- 2) Measure the RRC filtered mean power.
- 3) Measure the RRC filtered mean power of the first adjacent channels and the second adjacent channels.
- 4) Calculate the ratio of the power between the values measured in '2)' and '3)'.

5.10.5 Test requirements

If the measured adjacent channel RRC filtered mean power, derived in step 3), is greater than $-50,0$ dBm then the measured ACLR, derived in step 4), shall be higher than the limit in table 5.10.2.

Table 5.10.2: UE ACLR

Power Class	UE channel	ACLR limit
3	+5 MHz or -5 MHz	32,2 dB
3	+10 MHz or -10 MHz	42,2 dB
4	+5 MHz or -5 MHz	32,2 dB
4	+10 MHz or -10 MHz	42,2 dB

NOTE 1: The requirement shall still be met in the presence of switching transients.

NOTE 2: The ACLR requirements reflect what can be achieved with present state of the art technology.

NOTE 3: Requirement on the UE shall be reconsidered when the state of the art technology progresses.

NOTE 4: If the above Test Requirement differs from the Minimum Requirement then the Test Tolerance applied for this test is non-zero. The Test Tolerance for this test is defined in clause F.2 and the explanation of how the Minimum Requirement has been relaxed by the Test Tolerance is given in clause F.4.

5.11 Spurious Emissions

5.11.1 Definition and applicability

Spurious emissions are emissions which are caused by unwanted transmitter effects such as harmonics emission, parasitic emission, intermodulation products and frequency conversion products, but exclude out of band emissions.

The frequency boundary and the detailed transitions of the limits between the requirement for out band emissions and spectrum emissions are based on ITU-R Recommendations SM.329.

The requirements and this test apply to all types of UTRA for the FDD UE.

5.11.2 Minimum Requirements

These requirements are only applicable for frequencies, which are greater than 12.5 MHz away from the UE centre carrier frequency.

Table 5.11.1a: General spurious emissions requirements

Frequency Bandwidth	Measurement Bandwidth	Minimum requirement
$9 \text{ kHz} \leq f < 150 \text{ kHz}$	1 kHz	-36 dBm
$150 \text{ kHz} \leq f < 30 \text{ MHz}$	10 kHz	-36 dBm
$30 \text{ MHz} \leq f < 1 \text{ 000 MHz}$	100 kHz	-36 dBm
$1 \text{ GHz} \leq f < 12,75 \text{ GHz}$	1 MHz	-30 dBm

Table 5.11.1b: Additional spurious emissions requirements

Operating Band	Frequency Bandwidth	Measurement Bandwidth	Minimum requirement
I	$925 \text{ MHz} \leq f \leq 935 \text{ MHz}$	100 kHz	-67 dBm (see note)
	$935 \text{ MHz} < f \leq 960 \text{ MHz}$	100 kHz	-79 dBm (see note)
	$1805 \text{ MHz} \leq f \leq 1880 \text{ MHz}$	100 kHz	-71 dBm (see note)
	$1893.5 \text{ MHz} < f < 1919.6 \text{ MHz}$	300 kHz	-41 dBm
II	-	-	-
III	$925 \text{ MHz} \leq f \leq 935 \text{ MHz}$	100 kHz	-67 dBm (see note)
	$935 \text{ MHz} < f \leq 960 \text{ MHz}$	100 kHz	-79 dBm (see note)
	$2110 \text{ MHz} \leq f \leq 2170 \text{ MHz}$	3.84 MHz	-60 dBm (see note)
NOTE: The measurements are made on frequencies which are integer multiples of 200 kHz. As exceptions, up to five measurements with a level up to the applicable requirements defined in table 5.11.1a are permitted for each UARFCN used in the measurement			

The normative reference for this requirement is TS 25.101 [23] clause 6.6.3.1.

5.11.3 Test purpose

To verify that the UE spurious emissions do not exceed described value shown in table 5.11.1a and table 5.11.1b. Excess spurious emissions increase the interference to other systems.

5.11.4 Method of test

5.11.4.1 Initial conditions

Test environment: normal; see clauses G.2.1 and G.2.2.

Frequencies to be tested: low range, mid range, high range; see clause G.2.4.

- 1) Connect the SS to the UE antenna connector as shown in figure A.8.
- 2) A call is set up according to the Generic call setup procedure.
- 3) Enter the UE into loopback test mode and start the loopback test.

See TS 34.108 [3] and TS 34.109 [4] for details regarding generic call setup procedure and loopback test.

5.11.4.2 Procedure

- 1) Set and send continuously Up power control commands to the UE until the UE output power shall be maximum level.
- 2) Sweep the spectrum analyzer (or equivalent equipment) over a frequency range and measure the average power of spurious emission.

5.11.5 Test requirements

The measured average power of spurious emission, derived in step 2), shall not exceed the described value in tables 5.11.2a and 5.11.2b.

These requirements are only applicable for frequencies, which are greater than 12,5 MHz away from the UE centre carrier frequency.

Table 5.11.2a: General spurious emissions test requirements

Frequency Bandwidth	Measurement Bandwidth	Minimum requirement
$9 \text{ kHz} \leq f < 150 \text{ kHz}$	1 kHz	-36 dBm
$150 \text{ kHz} \leq f < 30 \text{ MHz}$	10 kHz	-36 dBm
$30 \text{ MHz} \leq f < 1 \text{ 000 MHz}$	100 kHz	-36 dBm
$1 \text{ GHz} \leq f < 12,75 \text{ GHz}$	1 MHz	-30 dBm

Table 5.11.2b: Additional spurious emissions test requirements

Operating Band	Frequency Bandwidth	Measurement Bandwidth	Minimum requirement
I	$925 \text{ MHz} \leq f \leq 935 \text{ MHz}$	100 kHz	-67 dBm (see note)
	$935 \text{ MHz} < f \leq 960 \text{ MHz}$	100 kHz	-79 dBm (see note)
	$1805 \text{ MHz} \leq f \leq 1880 \text{ MHz}$	100 kHz	-71 dBm (see note)
	$1893.5 \text{ MHz} < f < 1919.6 \text{ MHz}$	300 kHz	-41 dBm
II	-	-	-
III	$925 \text{ MHz} \leq f \leq 935 \text{ MHz}$	100 kHz	-67 dBm (see note)
	$935 \text{ MHz} < f \leq 960 \text{ MHz}$	100 kHz	-79 dBm (see note)
	$2110 \text{ MHz} \leq f \leq 2170 \text{ MHz}$	3.84 MHz	-60 dBm (see note)
NOTE: The measurements are made on frequencies which are integer multiples of 200 kHz. As exceptions, up to five measurements with a level up to the applicable requirements defined in table 5.11.1a are permitted for each UARFCN used in the measurement			

NOTE: If the above Test Requirement differs from the Minimum Requirement then the Test Tolerance applied for this test is non-zero. The Test Tolerance for this test is defined in clause F.2 and the explanation of how the Minimum Requirement has been relaxed by the Test Tolerance is given in clause F.4.

5.12 Transmit Intermodulation

5.12.1 Definition and applicability

The transmit intermodulation performance is a measure of the capability of the transmitter to inhibit the generation of signals in its non linear elements caused by presence of the wanted signal and an interfering signal reaching the transmitter via the antenna.

UE(s) transmitting in close vicinity of each other can produce intermodulation products, which can fall into the UE, or Node B receive band as an unwanted interfering signal. The UE transmit intermodulation attenuation is defined by the ratio of the RRC filtered mean power of the wanted signal to the RRC filtered mean power of the intermodulation product when an interfering CW signal is added at a level below the wanted signal.

The requirements and this test apply to all types of UTRA for the FDD UE.

5.12.2 Minimum Requirements

The UE transmit intermodulation shall not exceed the described value in table 5.12.1.

Table 5.12.1: Transmit Intermodulation

CW Signal Frequency Offset from Transmitting Carrier	5MHz	10MHz
Interference CW Signal Level	-40 dBc	
Intermodulation Product	-31 dBc	-41 dBc

The normative reference for this requirement is TS 25.101 [1] clause 6.7.1.

5.12.3 Test purpose

To verify that the UE transmit intermodulation does not exceed the described value in table 5.12.1.

An excess transmit intermodulation increases transmission errors in the up link own channel when other transmitter exists nearby.

5.12.4 Method of test

5.12.4.1 Initial conditions

Test environment: normal; see clauses G.2.1 and G.2.2.

Frequencies to be tested: mid range; see clause G.2.4.

- 1) Connect the SS to the UE antenna connector as shown in figure A.2.
- 2) A call is set up according to the Generic call setup procedure.
- 3) Enter the UE into loopback test mode and start the loopback test.

See TS 34.108 [3] and TS 34.109 [4] for details regarding generic call setup procedure and loopback test.

5.12.4.2 Procedure

- 1) Set and send continuously Up power control commands to the UE until the UE output power shall be maximum level.
- 2) Set the frequency of the CW generator to the offset 1 or offset 2 as shown in table 5.12.2.
- 3) Measure the RRC filtered mean power of the UE.
- 4) Search the intermodulation product signal, then measure the RRC filtered mean power of transmitting intermodulation, and calculate the ratio with the power measured in step 3).
- 5) Repeat the measurement with another tone offset.

5.12.5 Test requirements

The ratio derived in step 4), shall not exceed the described value in table 5.12.2.

Table 5.12.2: Transmit Intermodulation

CW Signal Frequency Offset from Transmitting Carrier	5MHz	10MHz
Interference CW Signal Level	-40 dBc	
Intermodulation Product	$[-31 + \text{TT}]$ dBc	$[-41 + \text{TT}]$ dBc

NOTE: If the above Test Requirement differs from the Minimum Requirement then the Test Tolerance applied for this test is non-zero. The Test Tolerance for this test is defined in clause F.2 and the explanation of how the Minimum Requirement has been relaxed by the Test Tolerance is given in clause F.4.

5.13 Transmit Modulation

5.13.1 Error Vector Magnitude (EVM)

5.13.1.1 Definition and applicability

The Error Vector Magnitude is a measure of the difference between the reference waveform and the measured waveform. This difference is called the error vector. Both waveforms pass through a matched Root Raised Cosine filter with bandwidth 3,84 MHz and roll-off $\alpha=0,22$. Both waveforms are then further modified by selecting the frequency, absolute phase, absolute amplitude and chip clock timing so as to minimise the error vector. The EVM result is defined as the square root of the ratio of the mean error vector power to the mean reference power expressed as a %. The measurement interval is one timeslot.

The requirements and this test apply to all types of UTRA for the FDD UE.

5.13.1.2 Minimum Requirements

The EVM shall not exceed 17,5 % for the parameters specified in table 5.13.1.

Table 5.13.1: Parameters for EVM

Parameter	Level / Status	Unit
Output power	≥ -20	dBm
Operating conditions	Normal conditions	
Power control step size	1	dB

The normative reference for this requirement is TS 25.101 [1] clause 6.8.2.1.

5.13.1.3 Test purpose

To verify that the EVM does not exceed 17,5 % for the specified parameters in table 5.13.1.

An excess EVM increases transmission errors in the up link own channel.

5.13.1.4 Method of test

5.13.1.4.1 Initial conditions

Test environment: normal, TL/VL, TL/VH, TH/VL, TH/VH, vibration; see clauses G.2.1, G.2.2 and G.2.3.

Frequencies to be tested: low range, mid range, high range; see clause G.2.4.

- 1) Connect the SS to the UE antenna connector as shown in figure A.1.
- 2) A call is set up according to the Generic call setup procedure.

- 3) Enter the UE into loopback test mode and start the loopback test.

See TS 34.108 [3] and TS 34.109 [4] for details regarding generic call setup procedure and loopback test.

5.13.1.4.2 Procedure

- 1) Set and send continuously Up power control commands to the UE until the UE output power shall be maximum level.
- 2) Measure the EVM using Global In-Channel Tx-Test (annex B).
- 3) Set the power level of UE to -20dBm or send Down power control commands (1dB step size should be used.) to the UE until UE output power shall be -20dBm with $\pm 1\text{dB}$ tolerance.
- 4) Repeat step 2).

5.13.1.5 Test requirements

The measured EVM, derived in step 2) and 4), shall not exceed 17,5 % for parameters specified in table 5.13.1 Parameters for EVM.

NOTE: If the above Test Requirement differs from the Minimum Requirement then the Test Tolerance applied for this test is non-zero. The Test Tolerance for this test is defined in clause F.2 and the explanation of how the Minimum Requirement has been relaxed by the Test Tolerance is given in clause F.4.

5.13.2 Peak code domain error

5.13.2.1 Definition and applicability

The Peak Code Domain Error is computed by projecting power of the error vector (as defined in clause 5.13.1.1) onto the code domain at a specific spreading factor. The Code Domain Error for every code in the domain is defined as the ratio of the mean power of the projection onto that code, to the mean power of the composite reference waveform expressed in dB. The Peak Code Domain Error is defined as the maximum value for the Code Domain Error for all codes. The measurement interval is one timeslot.

The requirements and this test apply only to the UE in which the multi-code transmission is provided.

5.13.2.2 Minimum Requirements

The peak code domain error shall not exceed -15 dB at spreading factor 4 for the parameters specified in table 5.13.3. The requirements are defined using the UL reference measurement channel (768 kbps) specified in clause C.2.5.

Table 5.13.3: Parameters for Peak code domain error

Parameter	Level / Status	Unit
Output power	≥ -20	dBm
Operating conditions	Normal conditions	
Power control step size	1	dB

The normative reference for this requirement is TS 25.101 [1] clause 6.8.3.1.

5.13.2.3 Test purpose

To verify that the UE peak code domain error does not exceed -15 dB for the specified parameters in table 5.13.3.

An excess peak code domain error increases transmission errors in the up link own channel.

5.13.2.4 Method of test

5.13.2.4.1 Initial conditions

Test environment: normal, TL/VL, TL/VH, TH/VL, TH/VH; see clauses G.2.1 and G.2.2.

Frequencies to be tested: low range, mid range, high range; see clause G.2.4.

- 1) Connect the SS to the UE antenna connector as shown in figure A.1.
- 2) A call is set up according to the Generic call setup procedure, and RF parameters are set up according to table 5.13.4.
- 3) Enter the UE into loopback test mode and start the loopback test.

See TS 34.108 [3] and TS 34.109 [4] for details regarding generic call setup procedure and loopback test.

Table 5.13.4: Test parameters for Peak code domain error

Parameter	Level / Status	Unit
Operating conditions	Normal conditions	
Uplink signal	multi-code	
Information bit rate	2*384	kbps
Power control step size	1	dB

5.13.2.4.2 Procedure

- 1) Set and send continuously Up power control commands to the UE until the UE output power shall be maximum level.
- 2) Measure the Peak code Domain error using Global In-Channel Tx-Test (annex B).
- 3) Set the power level of UE to -20dBm or send Down power control commands (1dB step size should be used.) to the UE until UE output power shall be -20dBm with ± 1 dB tolerance.
- 4) Repeat step 2).

5.13.2.5 Test requirements

The measured Peak code domain error, derived in step 2) and 4), shall not exceed -14 dB.

NOTE: If the above Test Requirement differs from the Minimum Requirement then the Test Tolerance applied for this test is non-zero. The Test Tolerance for this test is defined in clause F.2 and the explanation of how the Minimum Requirement has been relaxed by the Test Tolerance is given in clause F.4

6 Receiver Characteristics

6.1 General

Receiving performance test of the UE is implemented during communicating with the SS via air interface. The procedure is using normal call protocol until the UE is communicating on traffic channel basically. On the traffic channel, the UE provides special function for testing that is called Logical Test Interface and the UE is tested using this function (Refer to TS 34.109 [4])

Transmitting or receiving bit/symbol rate for test channel is shown in table 6.1.

Table 6.1: Bit / Symbol rate for Test Channel

Type of User Information	User bit rate	DL DPCH symbol rate	UL DPCH bit rate	Remarks
12,2 kbps reference measurement channel	12,2 kbps	30 ksps	60 kbps	Standard Test

Unless otherwise stated the receiver characteristics are specified at the antenna connector of the UE. For UE(s) with an integral antenna only, a reference antenna with a gain of 0 dBi is assumed. UE with an integral antenna may be taken into account by converting these power levels into field strength requirements, assuming a 0 dBi gain antenna. Receiver characteristics for UE(s) with multiple antennas/antenna connectors are FFS.

The UE antenna performance has a significant impact on system performance, and minimum requirements on the antenna efficiency are therefore intended to be included in future versions of the present document. It is recognised that different requirements and test methods are likely to be required for the different types of UE.

All the parameters in clause 6 are defined using the DL reference measurement channel (12,2 kbps) specified in clause C.3.1 and unless stated otherwise, with DL power control OFF.

The common RF test conditions of Rx Characteristics are defined in clause E.3.2, and each test conditions in this clause (clause 6) should refer clause E.3.2. Individual test conditions are defined in the paragraph of each test.

All Bit Error ratio (BER) measurements in clause 6 shall be performed according to the general rules for statistical testing in Annex F.6

6.2 Reference Sensitivity Level

6.2.1 Definition and applicability

The reference sensitivity level <REFSENS> is the minimum mean power received at the UE antenna port at which the Bit Error Ratio (BER) shall not exceed a specific value

The requirements and this test apply to all types of UTRA for the FDD UE.

6.2.2 Minimum Requirements

The BER shall not exceed 0,001 for the parameters specified in table 6.2.1.

Table 6.2.1: Test parameters for Reference Sensitivity Level

Operating Band	Unit	DPCH_Ec <REFSENS>	<REFI _{or} >
I	dBm/3.84 MHz	-117	-106.7
II	dBm/3.84 MHz	-115	-104.7
III	dBm/3.84 MHz	-114	-103.7
1. For Power class 3 this shall be at the maximum output power 2. For Power class 4 this shall be at the maximum output power			

The normative reference for this requirement is TS 25.101 [23] clause 7.3.1.

6.2.3 Test purpose

To verify that the UE BER shall not exceed 0,001 for the parameters specified in table 6.2.1.

The lack of the reception sensitivity decreases the coverage area at the far side from Node B.

6.2.4 Method of test

6.2.4.1 Initial conditions

Test environment: normal, TL/VL, TL/VH, TH/VL, TH/VH; see clauses G.2.1 and G.2.2.

Frequencies to be tested: low range, mid range, high range; see clause G.2.4.

- 1) Connect the SS to the UE antenna connector as shown in figure A.3.
- 2) A call is set up according to the Generic call setup procedure, and RF parameters are set up according to table 6.2.2.
- 3) Enter the UE into loopback test mode and start the loopback test.

See TS 34.108 [3] and TS 34.109 [4] for details regarding generic call setup procedure and loopback test.

6.2.4.2 Procedure

- 1) Set and send continuously Up power control commands to the UE until the UE output power shall be maximum level.
- 2) Measure the BER of DCH received from the UE at the SS.

6.2.5 Test requirements

The measured BER, derived in step 2), shall not exceed 0,001.

Table 6.2.2: Test parameters for Reference Sensitivity Level

Operating Band	Unit	DPCH_Ec <REFSENS>	<REF \hat{I}_{or} >
I	dBm/3.84 MHz	-116.3	-106
II	dBm/3.84 MHz	-114.3	-104
III	dBm/3.84 MHz	-113.3	-103
3. For Power class 3 this shall be at the maximum output power			
4. For Power class 4 this shall be at the maximum output power			

NOTE: If the above Test Requirement differs from the Minimum Requirement then the Test Tolerance applied for this test is non-zero. The Test Tolerance for this test is defined in clause F.2 and the explanation of how the Minimum Requirement has been relaxed by the Test Tolerance is given in clause F.4.

6.3 Maximum Input Level

6.3.1 Definition and applicability

This is defined as the maximum mean power received at the UE antenna port, which shall not degrade the specified BER performance.

The requirements and this test apply to all types of UTRA for the FDD UE.

6.3.2 Minimum requirements

The BER shall not exceed 0.001 for the parameters specified in table 6.3.

The reference for this requirement is TS 25.101 [1] clause 7.4.1.

NOTE: Since the spreading factor is large ($10\log(SF)=21\text{dB}$), the majority of the total input signal consists of the OCNS interference. The structure of OCNS signal is defined in clause E.3.3.

6.3.3 Test purpose

To verify that the UE BER shall not exceed 0,001 for the parameters specified in table 6.3.

The lack of the maximum input level decreases the coverage area at the near side from Node B.

6.3.4 Method of test

6.3.4.1 Initial conditions

Test environment: normal; see clauses G.2.1 and G.2.2.

Frequencies to be tested: mid range; see clause G.2.4.

- 1) Connect the SS to the UE antenna connector as shown in figure A.3.
- 2) RF parameters are set up according to table 6.3 and table E.3.3.
- 3) A call is set up according to the Generic call setup procedure specified in TS34.108[3] sub clause 7.3.2, with the following exception for information elements in RADIO BEARER SETUP message. With this exception, the Power Control Algorithm for the Uplink is set to algorithm 2.
- 4) Enter the UE into loopback test mode and start the loopback test.

Table 6.3A Contents of RADIO BEARER SETUP message: AM or UM

Information Element	Value/Remark
CHOICE channel requirement - Power Control Algorithm	Uplink DPCH info Algorithm2

See TS 34.108 [3] and TS 34.109 [4] for details regarding generic call setup procedure and loopback test.

Table 6.3: Test parameters for Maximum Input Level

Parameter	Level / Status	Unit
\hat{I}_{or}	-25	dBm / 3,84MHz
$\frac{DPCH_E_c}{I_{or}}$	-19	dB
UE transmitted mean power	20 (for Power class 3) 18 (for Power class 4)	dBm

6.3.4.2 Procedure

- 1) Set the power level of UE according to the table 6.3 or send the power control commands (1dB step size should be used.) to the UE until UE output power measured by Test System shall be kept at the specified power level with ± 1 dB tolerance.
- 2) Measure the BER of DCH received from the UE at the SS.

6.3.5 Test requirements

The measured BER, derived in step 1), shall not exceed 0,001.

6.4 Adjacent Channel Selectivity (ACS)

6.4.1 Definition and applicability

Adjacent Channel Selectivity (ACS) is a measure of a receiver's ability to receive a W-CDMA signal at its assigned channel frequency in the presence of an adjacent channel signal at a given frequency offset from the centre frequency of the assigned channel. ACS is the ratio of the receive filter attenuation on the assigned channel frequency to the receive filter attenuation on the adjacent channel(s).

The requirements and this test apply to all types of UTRA for the FDD UE.

6.4.2 Minimum Requirements

For the UE of power class 3 and 4, the BER shall not exceed 0,001 for the parameters specified in table 6.4.1. This test condition is equivalent to the ACS value 33 dB.

Table 6.4.1: Test parameters for Adjacent Channel Selectivity

Parameter	Level / Status	Unit
DPCH_Ec	-103	dBm / 3,84 MHz
\hat{I}_{or}	-92,7	dBm / 3,84 MHz
I_{oac} mean power (modulated)	-52	dBm
F_{uw} (offset)	-5 or +5	MHz
UE transmitted mean power	20 (for Power class 3) 18 (for Power class 4)	dBm

The normative reference for this requirement is TS 25.101 [1] clause 7.5.1.

NOTE: The I_{oac} (modulated) signal consists of the common channels needed for tests as specified in table E.4.1 and 16 dedicated data channels as specified in table E.3.6.

6.4.3 Test purpose

To verify that the UE BER does not exceed 0,001 for the test parameters specified in table 6.4.1.

The lack of the ACS decreases the coverage area when other transmitter exists in the adjacent channel.

6.4.4 Method of test

6.4.4.1 Initial conditions

Test environment: normal; see clauses G.2.1 and G.2.2.

Frequencies to be tested: mid range; see clause G.2.4.

- 1) Connect the SS to the UE antenna connector as shown in figure A.4.
- 2) RF parameters are set up according to table 6.4.2.
- 3) A call is set up according to the Generic call setup procedure specified in TS34.108[3] sub clause 7.3.2, with the following exception for information elements in RADIO BEARER SETUP message. With this exception, the Power Control Algorithm for the Uplink is set to algorithm 2.
- 4) Enter the UE into loopback test mode and start the loopback test.

Table 6.4.1A Contents of RADIO BEARER SETUP message: AM or UM

Information Element	Value/Remark
CHOICE channel requirement - Power Control Algorithm	Uplink DPCH info Algorithm2

See TS 34.108 [3] and TS 34.109 [4] for details regarding generic call setup procedure and loopback test.

6.4.4.2 Procedure

- 1) Set the parameters of the interference signal generator as shown in table 6.4.2.
- 2) Set the power level of UE according to the table 6.4.2 or send the power control commands (1dB step size should be used.) to the UE until UE output power measured by Test System shall be kept at the specified power level with ± 1 dB tolerance.
- 3) Measure the BER of DCH received from the UE at the SS.

6.4.5 Test requirements

The measured BER, derived in step 1), shall not exceed 0,001.

Table 6.4.2: Test parameters for Adjacent Channel Selectivity

Parameter	Level / Status	Unit
DPCH_Ec	-103	dBm / 3,84 MHz
I_{or}	-92,7	dBm / 3,84 MHz
I_{oac} mean power (modulated)	-52	dBm
F_{uw} (offset)	-5 or +5	MHz
UE transmitted mean power	20 (for Power class 3) 18 (for Power class 4)	dBm

NOTE: If the above Test Requirement differs from the Minimum Requirement then the Test Tolerance applied for this test is non-zero. The Test Tolerance for this test is defined in clause F.2 and the explanation of how the Minimum Requirement has been relaxed by the Test Tolerance is given in clause F.4.

6.5 Blocking Characteristics

6.5.1 Definition and applicability

The blocking characteristic is a measure of the receiver's ability to receive a wanted signal at its assigned channel frequency in the presence of an unwanted interferer on frequencies other than those of the spurious response or the adjacent channels, without this unwanted input signal causing a degradation of the performance of the receiver beyond a specified limit. The blocking performance shall apply at all frequencies except those at which a spurious response occur.

The requirements in clause 6.5.2.1 and 6.5.2.2 and this test apply to all types of UTRA for the FDD UE.

The requirements in clause 6.5.2.3 and this test apply to the FDD UE supporting band II or band III.

6.5.2 Minimum Requirements

6.5.2.1 Minimum Requirements (In-band blocking)

The BER shall not exceed 0,001 for the parameters specified in table 6.5.1.

The normative reference for this requirement is TS 25.101 [23] clause 7.6.1.

NOTE: I_{blocking} (modulated) consists of the common channels needed for tests as specified in table E.4.1 and 16 dedicated data channels as specified in table E3.6.

Table 6.5.1: Test parameters for In-band blocking characteristics

Parameter	Unit	Level	
DPCH_Ec	dBm/3.84 MHz	<REFSENS>+3 dB	
\hat{I}_{or}	dBm/3.84 MHz	<REF \hat{I}_{or} > + 3 dB	
I_{blocking} mean power (modulated)	dBm	-56 (for F_{uw} offset ± 10 MHz)	-44 (for F_{uw} offset ± 15 MHz)
UE transmitted mean power	dBm	20 (for Power class 3) 18 (for Power class 4)	

6.5.2.2 Minimum requirements (Out of-band blocking)

The BER shall not exceed 0.001 for the parameters specified in table 6.5.2. For table 6.5.2 up to 24 exceptions are allowed for spurious response frequencies in each assigned frequency channel when measured using a 1 MHz step size.

The normative reference for this requirement is TS 25.101 [23] clause 7.6.2.

Table 6.5.2: Test parameters for Out of band blocking characteristics

Parameter	Unit	Frequency range 1	Frequency range 2	Frequency range 3
DPCH_Ec	dBm/3.84 MHz	<REFSENS>+3 dB	<REFSENS>+3 dB	<REFSENS>+3 dB
\hat{I}_{or}	dBm/3.84 MHz	<REF \hat{I}_{or} > + 3 dB	<REF \hat{I}_{or} > + 3 dB	<REF \hat{I}_{or} > + 3 dB
$I_{blocking}(CW)$	dBm	-44	-30	-15
F_{uw} (Band I operation)	MHz	2050<f <2095 2185<f <2230	2025 <f <2050 2230 <f <2255	1 < f <2025 2255<f<12750
F_{uw} (Band II operation)	MHz	1870<f <1915 2005<f <2050	1845 <f <1870 2050 <f <2075	1 < f <1845 2075<f<12750
F_{uw} (Band III operation)	MHz	1745 <f <1790 1895<f <1940	1720 <f < 1745 1940<f < 1965	1 < f <1720 1965<f<12750
UE transmitted mean power	dBm	20 (for Power class 3) 18 (for Power class 4)		
Band I operation	For 2095<f<2110 MHz and 2170<f<2185 MHz, the appropriate in-band blocking or adjacent channel selectivity in clause 6.5.2 and clause 6.4.2 shall be applied.			
Band II operation	For 1915<f<1930 MHz and 1990<f<2005 MHz, the appropriate in-band blocking or adjacent channel selectivity in clause 6.5.2 and clause 6.4.2 shall be applied			
Band III operation	For 1790<f<1805 MHz and 1880<f<1895 MHz, the appropriate in-band blocking or adjacent channel selectivity in clause 6.5.2 and clause 6.4.2 shall be applied.			

6.5.2.3 Minimum requirements (Narrow band blocking)

The BER shall not exceed 0.001 for the parameters specified in table 6.5.3. This requirement is measure of a receiver's ability to receive a W-CDMA signal at its assigned channel frequency in the presence of an unwanted narrow band interferer at a frequency, which is less than the nominal channel spacing. The requirements and this test apply to UTRA for the FDD UE supporting band II or band III.

The normative reference for this requirement is TS 25.101 [23] clause 7.6.3

Table 6.5.3: Test parameters for narrow band blocking

Parameter	Unit	Band II	Band III
DPCH_Ec	dBm/3.84 MHz	<REFSENS> + 10 dB	<REFSENS> + 10 dB
\hat{I}_{or}	dBm/3.84 MHz	<REF \hat{I}_{or} > + 10 dB	<REF \hat{I}_{or} > + 10 dB
$I_{blocking}(GMSK)$	dBm	-57	-56
F_{uw} (offset)	MHz	2.7	2.8
UE transmitted mean power	dBm	20 (for Power class 3) 18 (for Power class 4)	

NOTE: $I_{blocking}(GMSK)$ is an interfering signal as defined in TS 45.004. It is a GMSK modulated carrier following the structure of the GSM signals, but with all modulating bits (including the midamble period) derived directly from a random or pseudo random data stream.

6.5.3 Test purpose

To verify that the UE BER does not exceed 0,001 for the parameters specified in table 6.5.1, table 6.5.2 and table 6.5.3. For table 6.5.2 up to (24) exceptions are allowed for spurious response frequencies in each assigned frequency channel when measured using a 1 MHz step size.

The lack of the blocking ability decreases the coverage area when other transmitter exists (except in the adjacent channels and spurious response).

6.5.4 Method of test

6.5.4.1 Initial conditions

For in-band case:

Test environment: normal; see clauses G.2.1 and G.2.2.

Frequencies to be tested: mid range; see clause G.2.4.

For out-of-band case:

Test environment: normal; see clauses G.2.1 and G.2.2.

Frequency to be tested: 1 arbitrary frequency chosen from the low, mid or high range; see clause G.2.4.

For narrow-band case:

Test environment: normal; see clauses G.2.1 and G.2.2.

Frequencies to be tested: mid range; see clause G.2.4.

- 1) Connect the SS to the UE antenna connector as shown in figure A.5.
- 2) RF parameters are set up according to table 6.5.4, table 6.5.5 and table 6.5.6.
- 3) A call is set up according to the Generic call setup procedure specified in TS34.108[3] sub clause 7.3.2, with the following exception for information elements in RADIO BEARER SETUP message. With this exception, the Power Control Algorithm for the Uplink is set to algorithm 2.
- 4) Enter the UE into loopback test mode and start the loopback test.

Table 6.5.3A Contents of RADIO BEARER SETUP message: AM or UM

Information Element	Value/Remark
CHOICE channel requirement - Power Control Algorithm	Uplink DPCH info Algorithm2

See TS 34.108 [3] and TS 34.109 [4] for details regarding generic call setup procedure and loopback test.

6.5.4.2 Procedure

- 1) Set the parameters of the CW generator or the interference signal generator as shown in table 6.5.4, 6.5.5 and table 6.5.6. For table 6.5.5, the frequency step size is 1 MHz.
- 2) Set the power level of UE according to the table 6.5.4, table 6.5.5, and table 6.5.6, or send the power control commands (1dB step size should be used.) to the UE until UE output power measured by Test System shall be kept at the specified power level with ± 1 dB tolerance.
- 3) Measure the BER of DCH received from the UE at the SS.
- 4) For table 6.5.5, record the frequencies for which BER exceed the test requirements.

6.5.5 Test requirements

For table 6.5.4, the measured BER, derived in step 2), shall not exceed 0.001. For table 6.5.5, the measured BER, derived in step 2) shall not exceed 0,001 except for the spurious response frequencies, recorded in step 3). The number of spurious response frequencies, recorded in step 3) shall not exceed 24. For table 6.5.6, the measured BER, derived in step 2), shall not exceed 0.001.

Table 6.5.4: Test parameters for In-band blocking characteristics

Parameter	Unit	Level	
DPCH_Ec	dBm/3.84 MHz	<REFSENS>+3 dB	
\hat{I}_{or}	dBm/3.84 MHz	<REF \hat{I}_{or} > + 3 dB	
$I_{blocking}$ mean power (modulated)	dBm	-56 (for F_{uw} offset ± 10 MHz)	-44 (for F_{uw} offset ± 15 MHz)
UE transmitted mean power	dBm	20 (for Power class 3) 18 (for Power class 4)	

Table 6.5.5: Test parameters for Out of band blocking characteristics

Parameter	Unit	Frequency range 1	Frequency range 2	Frequency range 3
DPCH_Ec	dBm/3.84 MHz	<REFSENS>+3 dB	<REFSENS>+3 dB	<REFSENS>+3 dB
\hat{I}_{or}	dBm/3.84 MHz	<REF \hat{I}_{or} > + 3 dB	<REF \hat{I}_{or} > + 3 dB	<REF \hat{I}_{or} > + 3 dB
$I_{blocking}$ (CW)	dBm	-44	-30	-15
F_{uw} (Band I operation)	MHz	2050<f <2095 2185<f <2230	2025 <f <2050 2230 <f <2255	1 < f <2025 2255<f <12750
F_{uw} (Band II operation)	MHz	1870<f <1915 2005<f <2050	1845 <f <1870 2050 <f <2075	1 < f <1845 2075<f <12750
F_{uw} (Band III operation)	MHz	1745 <f <1790 1895<f <1940	1720 <f < 1745 1940<f < 1965	1 < f <1720 1965<f <12750
UE transmitted mean power	dBm	20 (for Power class 3) 18 (for Power class 4)		
Band I operation	For 2095<f <2110 MHz and 2170<f <2185 MHz, the appropriate in-band blocking or adjacent channel selectivity in clause 6.5.2 and clause 6.4.2 shall be applied.			
Band II operation	For 1915<f <1930 MHz and 1990<f <2005 MHz, the appropriate in-band blocking or adjacent channel selectivity in clause 6.5.2 and clause 6.4.2 shall be applied			
Band III operation	For 1790<f <1805 MHz and 1880<f <1895 MHz, the appropriate in-band blocking or adjacent channel selectivity in clause 6.5.2 and clause 6.4.2 shall be applied.			

Table 6.5.6: Test parameters for narrow band blocking

Parameter	Unit	Band II	Band III
DPCH_Ec	dBm/3.84 MHz	<REFSENS> + 10 dB	<REFSENS> + 10 dB
\hat{I}_{or}	dBm/3.84 MHz	<REF \hat{I}_{or} > + 10 dB	<REF \hat{I}_{or} > + 10 dB
$I_{blocking}$ (GMSK)	dBm	-57	-56
F_{uw} (offset)	MHz	2.7	2.8
UE transmitted mean power	dBm	20 (for Power class 3) 18 (for Power class 4)	

NOTE: If the above Test Requirement differs from the Minimum Requirement then the Test Tolerance applied for this test is non-zero. The Test Tolerance for this test is defined in clause F.2 and the explanation of how the Minimum Requirement has been relaxed by the Test Tolerance is given in clause F.4.

6.6 Spurious Response

6.6.1 Definition and applicability

Spurious response is a measure of the receiver's ability to receive a wanted signal on its assigned channel frequency without exceeding a given degradation due to the presence of an unwanted CW interfering signal at any other frequency at which a response is obtained i.e. for which the out of band blocking limit is not met.

The requirements and this test apply to all types of UTRA for the FDD UE.

6.6.2 Minimum Requirements

The BER shall not exceed 0,001 for the parameters specified in table 6.6.1.

The normative reference for this requirement is TS 25.101 [23] clause 7.7.1.

Table 6.6.1: Test parameters for Spurious Response

Parameter	Level	Unit
DPCH_Ec	<REFSENS> +3 dB	dBm / 3,84MHz
I _{or}	<REFI _{or} > +3 dB	dBm / 3,84MHz
I _{blocking} (CW)	-44	dBm
F _{uw}	Spurious response frequencies	MHz
UE transmitted mean power	20 (for Power class 3) 18 (for Power class 4)	dBm

6.6.3 Test purpose

To verify that the UE BER does not exceed 0,001 for the parameters specified in table 6.6.1.

The lack of the spurious response ability decreases the coverage area when other unwanted interfering signal exists at any other frequency.

6.6.4 Method of test

6.6.4.1 Initial conditions

Test environment: normal; see clauses G.2.1 and G.2.2.

Frequency to be tested: the same frequency as chosen in clause 6.5.4.1 for Blocking characteristics out-of-band case.

- 1) Connect the SS to the UE antenna connector as shown in figure A.6.
- 2) RF parameters are set up according to table 6.6.2.
- 3) A call is set up according to the Generic call setup procedure specified in TS 34.108 [3] sub clause 7.3.2, with the following exception for information elements in RADIO BEARER SETUP message. With this exception, the Power Control Algorithm for the Uplink is set to algorithm 2.
- 4) Enter the UE into loopback test mode and start the loopback test.

Table 6.6.1A Contents of RADIO BEARER SETUP message: AM or UM

Information Element	Value/Remark
CHOICE channel requirement - Power Control Algorithm	Uplink DPCH info Algorithm2

See TS 34.108 [3] and TS 34.109 [4] for details regarding generic call setup procedure and loopback test.

6.6.4.2 Procedure

- 1) Set the parameter of the CW generator as shown in table 6.6.2. The spurious response frequencies are determined in step 3) of clause 6.5.4.2.
- 2) Set the power level of UE according to the table 6.6.2 or send the power control commands (1dB step size should be used.) to the UE until UE output power measured by Test System shall be kept at the specified power level with ± 1 dB tolerance.
- 3) Measure the BER of DCH received from the UE at the SS.

6.6.5 Test requirements

The measured BER, derived in step 2), shall not exceed 0,001.

Table 6.6.2: Test parameters for Spurious Response

Parameter	Level	Unit
DPCH_Ec	<REFSENS> +3 dB	dBm / 3,84MHz
I _{or}	<REF _{or} > +3 dB	dBm / 3,84MHz
I _{blocking(CW)}	-44	dBm
F _{uw}	Spurious response frequencies	MHz
UE transmitted mean power	20 (for Power class 3) 18 (for Power class 4)	dBm

NOTE: If the above Test Requirement differs from the Minimum Requirement then the Test Tolerance applied for this test is non-zero. The Test Tolerance for this test is defined in clause F.2 and the explanation of how the Minimum Requirement has been relaxed by the Test Tolerance is given in clause F.4.

6.7 Intermodulation Characteristics

6.7.1 Definition and applicability

Third and higher order mixing of the two interfering RF signals can produce an interfering signal in the band of the desired channel. Intermodulation response rejection is a measure of the capability of the receiver to receive a wanted signal on its assigned channel frequency in the presence of two or more interfering signals which have a specific frequency relationship to the wanted signal.

The requirements and this test apply to all types of UTRA for the FDD UE. The test parameters in tables 6.7.2 and 6.7.4 applies to the FDD UE supporting Band II and Band III.

6.7.2 Minimum Requirements

The BER shall not exceed 0,001 for the parameters specified in table 6.7.1 and in table 6.7.2.

The normative reference for this requirement is TS 25.101 [23] clause 7.8.1 and clause 7.8.2.

NOTE: I_{ouw2} (modulated) consists of the common channels needed for tests as specified in table E.4.1 and 16 dedicated data channels as specified in table E.3.6.

Table 6.7.1: Test parameters for Intermodulation Characteristics

Parameter	Level	Unit
DPCH_Ec	<REFSENS> +3 dB	dBm / 3,84 MHz
\hat{I}_{or}	<REF \hat{I}_{or} > +3 dB	dBm / 3,84 MHz
I_{ouw1} (CW)	-46	dBm
I_{ouw2} mean power (modulated)	-46	dBm
F_{uw1} (offset)	10 -10	MHz
F_{uw2} (offset)	20 -20	MHz
UE transmitted mean power	20 (for Power class 3) 18 (for Power class 4)	dBm

Table 6.7.2: Test parameters for narrow band intermodulation characteristics

Parameter	Unit	Band II	Band III
DPCH_Ec	dBm/3.84 MHz	<REFSENS>+ 10 dB	<REFSENS>+ 10 dB
\hat{I}_{or}	dBm/3.84 MHz	<REF \hat{I}_{or} > + 10 dB	[<REF \hat{I}_{or} > + 10 dB
I_{ouw1} (CW)	dBm	-44	-43
I_{ouw2} (GMSK)	dBm	-44	-43
F_{uw1} (offset)	MHz	3.5 -3.5	3.6 -3.6
F_{uw2} (offset)	MHz	5.9 -5.9	6.0 -6.0
UE transmitted mean power	dBm	20 (for Power class 3) 18 (for Power class 4)	

NOTE: I_{ouw2} (GMSK) is an interfering signal as defined in TS 45.004. It is a GMSK modulated carrier following the structure of the GSM signals, but with all modulating bits (including the midamble period) derived directly from a random or pseudo random data stream.

6.7.3 Test purpose

To verify that the UE BER does not exceed 0,001 for the parameters specified in table 6.7.1 and in table 6.7.2.

The lack of the intermodulation response rejection ability decreases the coverage area when two or more interfering signals, which have a specific frequency relationship to the wanted signal, exist.

6.7.4 Method of test

6.7.4.1 Initial conditions

Test environment: normal; see clauses G.2.1 and G.2.2.

Frequencies to be tested: mid range; see clause G.2.4.

- 1) Connect the SS to the UE antenna connector as shown in figure A.7.
- 2) RF parameters are set up according to table 6.7.3 and table 6.7.4.
- 3) A call is set up according to the Generic call setup procedure specified in TS 34.108 [3] sub clause 7.3.2, with the following exception for information elements in RADIO BEARER SETUP message. With this exception, the Power Control Algorithm for the Uplink is set to algorithm 2.
- 4) Enter the UE into loopback test mode and start the loopback test.

Table 6.7.2A Contents of RADIO BEARER SETUP message: AM or UM

Information Element	Value/Remark
CHOICE channel requirement - Power Control Algorithm	Uplink DPCH info Algorithm2

See TS 34.108 [3] and TS 34.109 [4] for details regarding generic call setup procedure and loopback test.

6.7.4.2 Procedure

- 1) Set the parameters of the CW generator and interference signal generator as shown in table 6.7.3 and in table 6.7.4.
- 2) Set the power level of UE according to the tables 6.7.3, and table 6.7.4 or send the power control commands (1dB step size should be used.) to the UE until UE output power measured by Test System shall be kept at the specified power level with ± 1 dB tolerance.
- 3) Measure the BER of DCH received from the UE at the SS.

6.7.5 Test requirements

The measured BER, derived in step 1), shall not exceed 0,001.

Table 6.7.3: Test parameters for Intermodulation Characteristics

Parameter	Level	Unit
DPCH_Ec	<REFSENS> +3 dB	dBm / 3.84 MHz
\hat{I}_{or}	<REF \hat{I}_{or} > +3 dB	dBm / 3.84 MHz
I_{ouw1} (CW)	-46	dBm
I_{ouw2} mean power (modulated)	-46	dBm
F_{uw1} (offset)	10 -10	MHz
F_{uw2} (offset)	20 -20	MHz
UE transmitted mean power	20 (for Power class 3) 18 (for Power class 4)	dBm

Table 6.7.4: Test parameters for narrow band intermodulation characteristics

Parameter	Unit	Band II		Band III	
DPCH_Ec	DdBm/3.84 MHz	<REFSENS>+ 10 dB		<REFSENS>+ 10 dB	
\hat{I}_{or}	DdBm/3.84 MHz	<REF \hat{I}_{or} > + 10 dB		[<REF \hat{I}_{or} > +10 dB	
I_{ouw1} (CW)	dBm	-44		-43	
I_{ouw2} (GMSK)	dBm	-44		-43	
F_{uw1} (offset)	MHz	3.5	-3.5	3.6	-3.6
F_{uw2} (offset)	MHz	5.9	-5.9	6.0	-6.0
UE transmitted mean power	dBm	20 (for Power class 3) 18 (for Power class 4)			

NOTE: If the above Test Requirement differs from the Minimum Requirement then the Test Tolerance applied for this test is non-zero. The Test Tolerance for this test is defined in clause F.2 and the explanation of how the Minimum Requirement has been relaxed by the Test Tolerance is given in clause F.4.

6.8 Spurious Emissions

6.8.1 Definition and applicability

The spurious emissions power is the power of emissions generated or amplified in a receiver that appear at the UE antenna connector.

The requirements and this test apply to all types of UTRA for the FDD UE.

6.8.2 Minimum Requirements

The power of any narrow band CW spurious emission shall not exceed the maximum level specified in table 6.8.1 and table 6.8.2.

Table 6.8.1: General receiver spurious emission requirements

Frequency Band	Measurement Bandwidth	Maximum level	Note
$30 \text{ MHz} \leq f < 1 \text{ GHz}$	100 kHz	-57 dBm	
$1 \text{ GHz} \leq f \leq 12,75 \text{ GHz}$	1 MHz	-47 dBm	

Table 6.8.2: Additional receiver spurious emission requirements

Operating band	Frequency Band	Measurement Bandwidth	Maximum level	Note
I	$1\,920 \text{ MHz} \leq f \leq 1\,980 \text{ MHz}$	3,84 MHz	-60 dBm	UE transmit band in URA_PCH, Cell_PCH and idle state
	$2\,110 \text{ MHz} \leq f \leq 2\,170 \text{ MHz}$	3,84 MHz	-60 dBm	UE receive band
II	$1850 \text{ MHz} \leq f \leq 1910 \text{ MHz}$	3.84 MHz	-60 dBm	UE transmit band in URA_PCH, Cell_PCH and idle state
	$1930 \text{ MHz} \leq f \leq 1990 \text{ MHz}$	3.84 MHz	-60 dBm	UE receive band
III	$1710 \text{ MHz} \leq f \leq 1785 \text{ MHz}$	3.84 MHz	-60 dBm	UE transmit band in URA_PCH, Cell_PCH and idle state
	$1805 \text{ MHz} \leq f \leq 1880 \text{ MHz}$	3.84 MHz	-60 dBm	UE receive band

The reference for this requirement is TS 25.101 [1] clause 7.9.1.

6.8.3 Test purpose

To verify that the UE spurious emission meets the specifications described in clause 6.8.2.

Excess spurious emissions increase the interference to other systems.

6.8.4 Method of test

6.8.4.1 Initial conditions

Test environment: normal; see clauses G.2.1 and G.2.2.

Frequencies to be tested: low range, mid range, high range; see clause G.2.4.

- 1) Connect a spectrum analyzer (or other suitable test equipment) to the UE antenna connector as shown in figure A.8.
- 2) RF parameters are setup according to table E.3.2.2.
- 3) A call is set up according to the setup procedure specified in TS34.108 [3] sub clause 7.3.3, with the following exceptions for information elements in System Information Block type3.

Information Element	Value/Remark
- Cell selection and re-selection info	
- CHOICE mode	FDD
- Sintrasearch	0 dB
- Sintersearch	0 dB
- RAT List	This parameter is configurable
- Ssearch,RAT	0 dB
- Maximum allowed UL TX power	Power level where Pcompensation=0

NOTE: The setup procedure (3) sets the UE into the CELL_FACH state. With this state and the SS level (2) it is ensured that UE continuously monitors the S-CCPCH and no cell reselections are performed [see 3GPP TS 25.304, clauses 5.2.3.and 5.2.6]. No transmission of the UE will interfere the measurement.

6.8.4.2 Procedure

- 1) Sweep the spectrum analyzer (or equivalent equipment) over a frequency range and measure the average power of spurious emission.

6.8.5 Test requirements

The all measured spurious emissions, derived in step 1), shall not exceed the maximum level specified in table 6.8.3 and table 6.8.4.

Table 6.8.3: General receiver spurious emission requirements

Frequency Band	Measurement Bandwidth	Maximum level	Note
$30 \text{ MHz} \leq f < 1 \text{ GHz}$	100 kHz	-57 dBm	
$1 \text{ GHz} \leq f \leq 12,75 \text{ GHz}$	1 MHz	-47 dBm	

Table 6.8.4: Additional receiver spurious emission requirements

Operating Band	Frequency Band	Measurement Bandwidth	Maximum level	Note
I	$1\,920 \text{ MHz} \leq f \leq 1\,980 \text{ MHz}$	3,84 MHz	-60 dBm	UE transmit band in URA_PCH, Cell_PCH and idle state
	$2\,110 \text{ MHz} \leq f \leq 2\,170 \text{ MHz}$	3,84 MHz	-60 dBm	UE receive band
II	$1850 \text{ MHz} \leq f \leq 1910 \text{ MHz}$	3.84 MHz	-60 dBm	UE transmit band in URA_PCH, Cell_PCH and idle state
	$1930 \text{ MHz} \leq f \leq 1990 \text{ MHz}$	3.84 MHz	-60 dBm	UE receive band
III	$1710 \text{ MHz} \leq f \leq 1785 \text{ MHz}$	3.84 MHz	-60 dBm	UE transmit band in URA_PCH, Cell_PCH and idle state
	$1805 \text{ MHz} \leq f \leq 1880 \text{ MHz}$	3.84 MHz	-60 dBm	UE receive band

NOTE: If the above Test Requirement differs from the Minimum Requirement then the Test Tolerance applied for this test is non-zero. The Test Tolerance for this test is defined in clause F.2 and the explanation of how the Minimum Requirement has been relaxed by the Test Tolerance is given in clause F.4.

7 Performance requirements

7.1 General

The performance requirements for the UE in this clause are specified for the measurement channels specified in annex C and table 7.1.1, the propagation conditions specified in clause 7.1.2 and the Down link Physical channels specified in annex D. Unless stated otherwise, DL power control is OFF.

The method for Block Error Ratio (BLER) measurement is specified in 3GPP TS 34.109 [4].

Table 7.1.1: Bit / Symbol rate for Test Channel

Type of User Information	User bit rate	DL DPCH symbol rate	DL DPCH bit rate	TTI (ms)
12,2 kbps reference measurement channel	12,2 kbps	30 ksps	60 kbps	20
64/144/384 kbps reference measurement channel	64 kbps	120 ksps	240 kbps	20
144kbps reference measurement channel	144 kbps	240 ksps	480 kbps	20
384 kbps reference measurement channel	384 kbps	480 ksps	960 kbps	10

The common RF test conditions of Performance requirement are defined in clause E.3.3, and each test conditions in this clause (clause 7) should refer clause E.3.3. Individual test conditions are defined in the paragraph of each test.

All Block Error ratio (BLER) measurements in clause 7 shall be performed according to the general rules for statistical testing in Annex F.6

7.1.1 Measurement Configurations

In all measurements UE should transmit with maximum power while receiving signals from Node B. This is guaranteed by the measurement configurations defined in Annex C (i.e. if the DTCH-DCH TFS consists of a single transport format, it is not blocked by the UE as stated in 3GPP TS 25.331). Chip Rate is specified to be 3,84 MHz.

It is assumed that fields inside DPCH have the same energy per PN chip. Also, if the power of S-CCPCH is not specified in the test parameter table, it should be set to zero. The power of OCNS should be adjusted that the power ratios (E_c/I_{or}) of all specified forward channels add up to one.

Measurement configurations for different scenarios are shown in figure A.9, figure A.10 and figure A.11.

7.1.2 Definition of Additive White Gaussian Noise (AWGN) Interferer

The minimum bandwidth of the AWGN interferer shall be 1,5 times chip rate of the radio access mode (e.g. 5,76 MHz for a chip rate of 3,84 Mcps). The flatness across this minimum bandwidth shall be less than $\pm 0,5$ dB and the peak to average ratio at a probability of 0,001 % shall exceed 10 dB.

7.2 Demodulation in Static Propagation conditions

7.2.1 Demodulation of Dedicated Channel (DCH)

7.2.1.1 Definition and applicability

The receive characteristic of the Dedicated Channel (DCH) in the static environment is determined by the Block Error Ratio (BLER). BLER is specified for each individual data rate of the DCH. DCH is mapped into the Dedicated Physical Channel (DPCH).

The UE shall be tested only according to the data rate, supported. The data-rate-corresponding requirements shall apply to the UE.

7.2.1.2 Minimum requirements

For the parameters specified in table 7.2.1.1 the average downlink $\frac{DPCH - E_c}{I_{or}}$ power ratio shall be below the specified value for the BLER shown in table 7.2.1.2. These requirements are applicable for TFCS size 16.

Table 7.2.1.1: DCH parameters in static propagation conditions

Parameter	Test 1	Test 2	Test 3	Test 4	Unit
Phase reference	P-CPICH				
\hat{I}_{or}/I_{oc}	-1				dB
I_{oc}	-60				dBm / 3,84 MHz
Information Data Rate	12,2	64	144	384	kbps

Table 7.2.1.2: DCH requirements in static propagation conditions

Test Number	$\frac{DPCH - E_c}{I_{or}}$	BLER
1	-16,6 dB	10^{-2}
2	-13,1 dB	10^{-1}
	-12,8 dB	10^{-2}
3	-9,9 dB	10^{-1}
	-9,8 dB	10^{-2}
4	-5,6 dB	10^{-1}
	-5,5 dB	10^{-2}

The reference for this requirement is TS 25.101 [1] clause 8.2.3.1.

7.2.1.3 Test purpose

To verify the ability of the receiver to receive a predefined test signal, representing a static propagation channel for the wanted and for the co-channel signals from serving and adjacent cells, with a BLER not exceeding a specified value.

7.2.1.4 Method of test

7.2.1.4.1 Initial conditions

Test environment: normal; see clauses G.2.1 and G.2.2.

Frequencies to be tested: mid range; see clause G.2.4.

1. Connect the SS and an AWGN noise source to the UE antenna connector as shown in figure A.9.
2. Set up a call according to the Generic call setup procedure.
3. Set the test parameters for test 1-4 as specified in table 7.2.1.3.
4. Enter the UE into loopback test mode and start the loopback test.

7.2.1.4.2 Procedures

1. Measure BLER of DCH.

7.2.1.5 Test requirements

For the parameters specified in table 7.2.1.3 the average downlink $\frac{DPCH - E_c}{I_{or}}$ power ratio shall be below the specified value for the BLER shown in table 7.2.1.4. These requirements are applicable for TFCS size 16.

Table 7.2.1.3: DCH parameters in static propagation conditions

Parameter	Test 1	Test 2	Test 3	Test 4	Unit
Phase reference	P-CPICH				
\hat{I}_{or}/I_{oc}	-0,7				dB
I_{oc}	-60				dBm / 3,84 MHz
Information Data Rate	12,2	64	144	384	kbps

Table 7.2.1.4: DCH requirements in static propagation conditions

Test Number	$\frac{DPCH - E_c}{I_{or}}$	BLER
1	-16,5 dB	10^{-2}
2	-13,0 dB	10^{-1}
	-12,7 dB	10^{-2}
3	-9,8 dB	10^{-1}
	-9,7 dB	10^{-2}
4	-5,5 dB	10^{-1}
	-5,4 dB	10^{-2}

NOTE: If the above Test Requirement differs from the Minimum Requirement then the Test Tolerance applied for this test is non-zero. The Test Tolerance for this test is defined in clause F.2 and the explanation of how the Minimum Requirement has been relaxed by the Test Tolerance is given in clause F.4.

7.3 Demodulation of DCH in Multi-path Fading Propagation conditions

7.3.1 Single Link Performance

7.3.1.1 Definition and applicability

The receive characteristics of the Dedicated Channel (DCH) in different multi-path fading environments are determined by the Block Error Ratio (BLER) values. BLER is measured for the each of the individual data rate specified for the DPCH. DCH is mapped into in Dedicated Physical Channel (DPCH).

The UE shall be tested only according to the data rate, supported. The data-rate-corresponding requirements shall apply to the UE.

7.3.1.2 Minimum requirements

For the parameters specified in tables 7.3.1.1, 7.3.1.3, 7.3.1.5, 7.3.1.7 and 7.3.1.9 the average downlink $\frac{DPCH - E_c}{I_{or}}$ power ratio shall be below the specified value for the BLER shown in tables 7.3.1.2, 7.3.1.4, 7.3.1.6, 7.3.1.8 and 7.3.1.10. These requirements are applicable for TFCS size 16.

Table 7.3.1.1: DCH parameters in multi-path fading propagation conditions (Case 1)

Parameter	Test 1	Test 2	Test 3	Test 4	Unit
Phase reference	P-CPICH				
\hat{I}_{or}/I_{oc}	9				dB
I_{oc}	-60				dBm / 3,84 MHz
Information Data Rate	12,2	64	144	384	kbps

Table 7.3.1.2: DCH requirements in multi-path fading propagation conditions (Case 1)

Test Number	$\frac{DPCH_E_c}{I_{or}}$	BLER
1	-15,0 dB	10^{-2}
2	-13,9 dB	10^{-1}
	-10,0 dB	10^{-2}
3	-10,6 dB	10^{-1}
	-6,8 dB	10^{-2}
4	-6,3 dB	10^{-1}
	-2,2 dB	10^{-2}

Table 7.3.1.3: DCH parameters in multi-path fading propagation conditions (Case 2)

Parameter	Test 5	Test 6	Test 7	Test 8	Unit
Phase reference	P-CPICH				
\hat{I}_{or}/I_{oc}	-3	-3	3	6	dB
I_{oc}	-60				dBm / 3,84 MHz
Information Data Rate	12,2	64	144	384	kbps

Table 7.3.1.4: DCH requirements in multi-path fading propagation conditions (Case 2)

Test Number	$\frac{DPCH_E_c}{I_{or}}$	BLER
5	-7,7 dB	10^{-2}
6	-6,4 dB	10^{-1}
	-2,7 dB	10^{-2}
7	-8,1 dB	10^{-1}
	-5,1 dB	10^{-2}
8	-5,5 dB	10^{-1}
	-3,2 dB	10^{-2}

Table 7.3.1.5: DCH parameters in multi-path fading propagation conditions (Case 3)

Parameter	Test 9	Test 10	Test 11	Test 12	Unit
Phase reference	P-CPICH				
\hat{I}_{or}/I_{oc}	-3	-3	3	6	dB
I_{oc}	-60				dBm / 3,84 MHz
Information Data Rate	12,2	64	144	384	kbps

Table 7.3.1.6: DCH requirements in multi-path fading propagation conditions (Case 3)

Test Number	$\frac{DPCH_E_c}{I_{or}}$	BLER
9	-11,8 dB	10^{-2}
10	-8,1 dB	10^{-1}
	-7,4 dB	10^{-2}
	-6,8 dB	10^{-3}
11	-9,0 dB	10^{-1}
	-8,5 dB	10^{-2}
	-8,0 dB	10^{-3}
12	-5,9 dB	10^{-1}
	-5,1 dB	10^{-2}
	-4,4 dB	10^{-3}

Table 7.3.1.7: DCH parameters in multi-path fading propagation conditions (Case 1) with S-CPICH

Parameter	Test 13	Test 14	Test 15	Test 16	Unit
Phase reference	S-CPICH				
\hat{I}_{or}/I_{oc}	9				dB
I_{oc}	-60				dBm / 3,84 MHz
Information Data Rate	12,2	64	144	384	kbps

Table 7.3.1.8: DCH requirements in multi-path fading propagation conditions (Case 1) with S-CPICH

Test Number	$\frac{DPCH_E_c}{I_{or}}$	BLER
13	-15,0 dB	10^{-2}
14	-13,9 dB	10^{-1}
	-10,0 dB	10^{-2}
15	-10,6 dB	10^{-1}
	-6,8 dB	10^{-2}
16	-6,3 dB	10^{-1}
	-2,2 dB	10^{-2}

Table 7.3.1.9: DCH parameters in multi-path fading propagation conditions (Case 6)

Parameter	Test 17	Test 18	Test 19	Test 20	Unit
Phase reference	P-CPICH				
\hat{I}_{or}/I_{oc}	-3	-3	3	6	dB
I_{oc}	-60				dBm / 3,84 MHz
Information Data Rate	12,2	64	144	384	kbps

Table 7.3.1.10: DCH requirements in multi-path fading propagation conditions (Case 6)

Test Number	$\frac{DPCH_E_c}{I_{or}}$	BLER
17	-8,8 dB	10^{-2}
18	-5,1 dB	10^{-1}
	-4,4 dB	10^{-2}
	-3,8 dB	10^{-3}
19	-6,0 dB	10^{-1}
	-5,5 dB	10^{-2}
	-5,0 dB	10^{-3}
20	-2,9 dB	10^{-1}
	-2,1 dB	10^{-2}
	-1,4 dB	10^{-3}

The reference for this requirement is TS 25.101 [1] clause 8.3.1.1.

7.3.1.3 Test purpose

To verify the ability of the receiver to receive a predefined test signal, representing a multi-path fading propagation channel for the wanted and for the co-channel signals from serving and adjacent cells, with a BLER not exceeding a specified value.

7.3.1.4 Method of test

7.3.1.4.1 Initial conditions

Test environment: normal; see clauses G.2.1 and G.2.2.

Frequencies to be tested: mid range; see clause G.2.4.

1. Connect the SS, multi-path fading simulator and an AWGN noise source to the UE antenna connector as shown in figure A.10.
2. Set up a call according to the Generic call setup procedure.
3. Set the test parameters for test 1-20 as specified table 7.3.1.11, table 7.3.1.13, table 7.3.1.15, table 7.3.1.17 and table 7.3.1.19.
4. Enter the UE into loopback test mode and start the loopback test.
5. Setup fading simulators as fading condition case 1, case 2, case 3 and case 6, which are described in table D.2.2.1.

7.3.1.4.2 Procedures

1. Measure BLER of DCH.

7.3.1.5 Test requirements

For the parameters specified in tables 7.3.1.11, 7.3.1.13, 7.3.1.15, 7.3.1.17 and 7.3.1.19 the average downlink $\frac{DPCH_E_c}{I_{or}}$ power ratio shall be below the specified value for the BLER shown in tables 7.3.1.12, 7.3.1.14, 7.3.1.16, 7.3.1.18 and 7.3.1.20. These requirements are applicable for TFCS size 16.

Table 7.3.1.11: DCH parameters in multi-path fading propagation conditions (Case 1)

Parameter	Test 1	Test 2	Test 3	Test 4	Unit
Phase reference	P-CPICH				
\hat{I}_{or}/I_{oc}	9,6				dB
I_{oc}	-60				dBm / 3,84 MHz
Information Data Rate	12,2	64	144	384	kbps

Table 7.3.1.12: DCH requirements in multi-path fading propagation conditions (Case 1)

Test Number	$\frac{DPCH - E_c}{I_{or}}$	BLER
1	-14,9 dB	10^{-2}
2	-13,8 dB	10^{-1}
	-9,9 dB	10^{-2}
3	-10,5 dB	10^{-1}
	-6,7 dB	10^{-2}
4	-6,2 dB	10^{-1}
	-2,1 dB	10^{-2}

Table 7.3.1.13: DCH parameters in multi-path fading propagation conditions (Case 2)

Parameter	Test 5	Test 6	Test 7	Test 8	Unit
Phase reference	P-CPICH				
\hat{I}_{or}/I_{oc}	-2,4	-2,4	3,6	6,6	dB
I_{oc}	-60				dBm / 3,84 MHz
Information Data Rate	12,2	64	144	384	kbps

Table 7.3.1.14: DCH requirements in multi-path fading propagation conditions (Case 2)

Test Number	$\frac{DPCH - E_c}{I_{or}}$	BLER
5	-7,6 dB	10^{-2}
6	-6,3 dB	10^{-1}
	-2,6 dB	10^{-2}
7	-8,0 dB	10^{-1}
	-5,0 dB	10^{-2}
8	-5,4 dB	10^{-1}
	-3,1 dB	10^{-2}

Table 7.3.1.15: DCH parameters in multi-path fading propagation conditions (Case 3)

Parameter	Test 9	Test 10	Test 11	Test 12	Unit
Phase reference	P-CPICH				
\hat{I}_{or}/I_{oc}	-2,4	-2,4	3,6	6,6	dB
I_{oc}	-60				dBm / 3,84 MHz
Information Data Rate	12,2	64	144	384	kbps

Table 7.3.1.16: DCH requirements in multi-path fading propagation conditions (Case 3)

Test Number	$\frac{DPCH_E_c}{I_{or}}$	BLER
9	-11,7 dB	10^{-2}
10	-8,0 dB	10^{-1}
	-7,3 dB	10^{-2}
	-6,7 dB	10^{-3}
11	-8,9 dB	10^{-1}
	-8,4 dB	10^{-2}
	-7,9 dB	10^{-3}
12	-5,8 dB	10^{-1}
	-5,0 dB	10^{-2}
	-4,3 dB	10^{-3}

Table 7.3.1.17: DCH parameters in multi-path fading propagation conditions (Case 1) with S-CPICH

Parameter	Test 13	Test 14	Test 15	Test 16	Unit
Phase reference	S-CPICH				
\hat{I}_{or}/I_{oc}	9,6				dB
I_{oc}	-60				dBm / 3,84 MHz
Information Data Rate	12,2	64	144	384	kbps

Table 7.3.1.18: DCH requirements in multi-path fading propagation conditions (Case 1) with S-CPICH

Test Number	$\frac{DPCH_E_c}{I_{or}}$	BLER
13	-14,9 dB	10^{-2}
14	-13,8 dB	10^{-1}
	-9,9 dB	10^{-2}
15	-10,5 dB	10^{-1}
	-6,7 dB	10^{-2}
16	-6,2 dB	10^{-1}
	-2,1 dB	10^{-2}

Table 7.3.1.19: DCH parameters in multi-path fading propagation conditions (Case 6)

Parameter	Test 17	Test 18	Test 19	Test 20	Unit
Phase reference	P-CPICH				
\hat{I}_{or}/I_{oc}	-2,4	-2,4	3,6	6,6	dB
I_{oc}	-60				dBm / 3,84 MHz
Information Data Rate	12,2	64	144	384	kbps

Table 7.3.1.20: DCH requirements in multi-path fading propagation conditions (Case 6)

Test Number	$\frac{DPCH_E_c}{I_{or}}$	BLER
17	-8,7 dB	10^{-2}
18	-5,0 dB	10^{-1}
	-4,3 dB	10^{-2}
	-3,7 dB	10^{-3}
19	-5,9 dB	10^{-1}
	-5,4 dB	10^{-2}
	-4,9 dB	10^{-3}
20	-2,8 dB	10^{-1}
	-2,0 dB	10^{-2}
	-1,3 dB	10^{-3}

NOTE: If the above Test Requirement differs from the Minimum Requirement then the Test Tolerance applied for this test is non-zero. The Test Tolerance for this test is defined in clause F.2 and the explanation of how the Minimum Requirement has been relaxed by the Test Tolerance is given in clause F.4.

7.4 Demodulation of DCH in Moving Propagation conditions

7.4.1 Single Link Performance

7.4.1.1 Definition and applicability

The receive single link performance of the Dedicated Channel (DCH) in dynamic moving propagation conditions are determined by the Block Error Ratio (BLER) values. BLER is measured for the each of the individual data rate specified for the DPCH. DCH is mapped into Dedicated Physical Channel (DPCH).

The UE shall be tested only according to the data rate, supported. The data-rate-corresponding requirements shall apply to the UE.

7.4.1.2 Minimum requirements

For the parameters specified in table 7.4.1.1 the average downlink $\frac{DPCH_E_c}{I_{or}}$ power ratio shall be below the specified value for the BLER shown in table 7.4.1.2.

Table 7.4.1.1: DCH parameters in moving propagation conditions

Parameter	Test 1	Test 2	Unit
Phase reference	P-CPICH		
\hat{I}_{or}/I_{oc}	-1		dB
I_{oc}	-60		dBm / 3,84 MHz
Information Data Rate	12,2	64	kbps

Table 7.4.1.2: DCH requirements in moving propagation conditions

Test Number	$\frac{DPCH_E_c}{I_{or}}$	BLER
1	-14,5 dB	10^{-2}
2	-10,9 dB	10^{-2}

The reference for this requirement is TS 25.101 [1] clause 8.4.1.1.

7.4.1.3 Test purpose

To verify the ability of the receiver to receive a predefined test signal, representing a moving propagation channel for the wanted and for the co-channel signals from serving and adjacent cells, with a BLER not exceeding a specified value.

7.4.1.4 Method of test

7.4.1.4.1 Initial conditions

Test environment: normal; see clauses G.2.1 and G.2.2.

Frequencies to be tested: mid range; see clause G.2.4.

1. Connect the SS and an AWGN noise source to the UE antenna connector as shown in figure A.10.
2. Set up a call according to the Generic call setup procedure.
3. Set the test parameters as specified in table 7.4.1.3.
4. Enter the UE into loopback test mode and start the loopback test.
5. Setup fading simulator as moving propagation condition, which is described in clause D.2.3.

7.4.1.4.2 Procedures

1. Measure BLER of DCH.

7.4.1.5 Test requirements

For the parameters specified in table 7.4.1.3 the average downlink $\frac{DPCH - E_c}{I_{or}}$ power ratio shall be below the specified value for the BLER shown in table 7.4.1.4.

Table 7.4.1.3: DCH parameters in moving propagation conditions

Parameter	Test 1	Test 2	Unit
Phase reference	P-CPICH		
\hat{I}_{or}/I_{oc}	-0,4		dB
I_{oc}	-60		dBm / 3,84 MHz
Information Data Rate	12,2	64	kbps

Table 7.4.1.4: DCH requirements in moving propagation conditions

Test Number	$\frac{DPCH - E_c}{I_{or}}$	BLER
1	-14,4 dB	10^{-2}
2	-10,8 dB	10^{-2}

NOTE: If the above Test Requirement differs from the Minimum Requirement then the Test Tolerance applied for this test is non-zero. The Test Tolerance for this test is defined in clause F.2 and the explanation of how the Minimum Requirement has been relaxed by the Test Tolerance is given in clause F.4.

7.5 Demodulation of DCH in Birth-Death Propagation conditions

7.5.1 Single Link Performance

7.5.1.1 Definition and applicability

The receive single link performance of the Dedicated Channel (DCH) in dynamic birth-death propagation conditions are determined by the Block Error Ratio (BLER) values. BLER is measured for the each of the individual data rate specified for the DPCH. DCH is mapped into Dedicated Physical Channel (DPCH).

The UE shall be tested only according to the data rate, supported. The data-rate-corresponding requirements shall apply to the UE.

7.5.1.2 Minimum requirements

For the parameters specified in table 7.5.1.1 the average downlink $\frac{DPCH - E_c}{I_{or}}$ power ratio shall be below the specified value for the BLER shown in table 7.5.1.2.

Table 7.5.1.1: DCH parameters in birth-death propagation conditions

Parameter	Test 1	Test 2	Unit
Phase reference	P-CPICH		
\hat{I}_{or}/I_{oc}	-1		dB
I_{oc}	-60		dBm / 3,84 MHz
Information Data Rate	12,2	64	kbps

Table 7.5.1.2: DCH requirements in birth-death propagation conditions

Test Number	$\frac{DPCH - E_c}{I_{or}}$	BLER
1	-12,6 dB	10^{-2}
2	-8,7 dB	10^{-2}

The reference for this requirement is TS 25.101 [1] clause 8.5.1.1.

7.5.1.3 Test purpose

To verify the ability of the receiver to receive a predefined test signal, representing a birth-death propagation channel for the wanted and for the co-channel signals from serving and adjacent cells, with a BLER not exceeding a specified value.

7.5.1.4 Method of test

7.5.1.4.1 Initial conditions

Test environment: normal; see clauses G.2.1 and G.2.2.

Frequencies to be tested: mid range; see clause G.2.4.

1. Connect the SS and an AWGN noise source to the UE antenna connector as shown in figure A.10.
2. Set up a call according to the Generic call setup procedure.
3. Set the test parameters as specified in table 7.5.1.3.
4. Enter the UE into loopback test mode and start the loopback test.
5. Setup fading simulator as birth-death propagation condition, which is described in clause D.2.4.

7.5.1.4.2 Procedures

1. Measure BLER of DCH.

7.5.1.5 Test requirements

For the parameters specified in table 7.5.1.3 the average downlink $\frac{DPCH_E_c}{I_{or}}$ power ratio shall be below the specified value for the BLER shown in table 7.5.1.4.

Table 7.5.1.3: DCH parameters in birth-death propagation conditions

Parameter	Test 1	Test 2	Unit
Phase reference	P-CPICH		
\hat{I}_{or}/I_{oc}	-0,4		dB
I_{oc}	-60		dBm / 3,84 MHz
Information Data Rate	12,2	64	kbps

Table 7.5.1.4: DCH requirements in birth-death propagation conditions

Test Number	$\frac{DPCH_E_c}{I_{or}}$	BLER
1	-12,5 dB	10^{-2}
2	-8,6 dB	10^{-2}

NOTE: If the above Test Requirement differs from the Minimum Requirement then the Test Tolerance applied for this test is non-zero. The Test Tolerance for this test is defined in clause F.2 and the explanation of how the Minimum Requirement has been relaxed by the Test Tolerance is given in clause F.4.

7.6 Demodulation of DCH in downlink Transmit diversity modes

7.6.1 Demodulation of DCH in open-loop transmit diversity mode

7.6.1.1 Definition and applicability

The receive characteristic of the Dedicated Channel (DCH) in open loop transmit diversity mode is determined by the Block Error Ratio (BLER). DCH is mapped into in Dedicated Physical Channel (DPCH).

The requirements and this test apply to all types of UTRA for the FDD UE.

7.6.1.2 Minimum requirements

For the parameters specified in table 7.6.1.1 the average downlink $\frac{DPCH_E_c}{I_{or}}$ power ratio shall be below the specified value for the BLER shown in table 7.6.1.2.

Table 7.6.1.1: Test parameters for DCH reception in a open-loop transmit diversity scheme (Propagation condition: Case 1)

Parameter	Test 1	Unit
Phase reference	P-CPICH	
\hat{I}_{or}/I_{oc}	9	dB
I_{oc}	-60	dBm / 3,84 MHz
Information data rate	12,2	kbps

Table 7.6.1.2: Test requirements for DCH reception in open-loop transmit diversity scheme

Test Number	$\frac{DPCH_E_c}{I_{or}}$ (antenna 1/2)	BLER
1	-16,8 dB	10^{-2}

The reference for this requirement is TS 25.101 [1] clause 8.6.1.1.

7.6.1.3 Test purpose

To verify that UE reliably demodulates the DPCH of the Node B while open loop transmit diversity is enabled during the connection.

7.6.1.4 Method of test

7.6.1.4.1 Initial conditions

Test environment: normal; see clauses G.2.1 and G.2.2.

Frequencies to be tested: mid range; see clause G.2.4.

- 1) Connect SS, multi-path fading simulators and an AWGN source to the UE antenna connector as shown in figure A.12.
- 2) Set up a call according to the Generic call setup procedure.
- 3) RF parameters are set up according to table 7.6.1.3 and table E 3.4.
- 4) Enter the UE into loopback test mode and start the loopback test.
- 5) Activate open loop Tx diversity function.
- 6) Set up fading simulators as fading condition case 1, which is described in table D.2.2.1.

See TS 34.108 [3] and TS 34.109 [4] for details regarding generic call setup procedure and loopback test.

7.6.1.4.2 Procedure

- 1) Measure BLER in points specified in table 7.6.1.4.

7.6.1.5 Test Requirements

For the parameters specified in table 7.6.1.3 the average downlink $\frac{DPCH_E_c}{I_{or}}$ power ratio shall be below the specified value for the BLER shown in table 7.6.1.4.

Table 7.6.1.3: Test parameters for DCH reception in an open-loop transmit diversity scheme (Propagation condition: Case 1)

Parameter	Test 1	Unit
Phase reference	P-CPICH	
\hat{I}_{or}/I_{oc}	9,8	dB
I_{oc}	-60	dBm / 3,84 MHz
Information data rate	12,2	kbps

Table 7.6.1.4: Test requirements for DCH reception in open-loop transmit diversity scheme

Test Number	$\frac{DPCH_E_c}{I_{or}}$ (antenna 1/2)	BLER
1	-16,7 dB	10^{-2}

NOTE: If the above Test Requirement differs from the Minimum Requirement then the Test Tolerance applied for this test is non-zero. The Test Tolerance for this test is defined in clause F.2 and the explanation of how the Minimum Requirement has been relaxed by the Test Tolerance is given in clause F.4.

7.6.2 Demodulation of DCH in closed loop transmit diversity mode

7.6.2.1 Definition and applicability

The receive characteristic of the dedicated channel (DCH) in closed loop transmit diversity mode is determined by the Block Error Ratio (BLER). DCH is mapped into in Dedicated Physical Channel (DPCH).

The requirements and this test apply to all types of UTRA for the FDD UE.

7.6.2.2 Minimum requirements

For the parameters specified in table 7.6.2.1 the average downlink $\frac{DPCH_E_c}{I_{or}}$ power ratio shall be below the specified value for the BLER shown in table 7.6.2.2.

Table 7.6.2.1: Test Parameters for DCH Reception in closed loop transmit diversity mode (Propagation condition: Case 1)

Parameter	Test 1 (Mode 1)	Test 2 (Mode 2)	Unit
\hat{I}_{or}/I_{oc}	9	9	dB
I_{oc}	-60	-60	dBm / 3,84 MHz
Information data rate	12,2	12,2	kbps
Feedback error ratio	4	4	%

Table 7.6.2.2: Test requirements for DCH reception in closed loop transmit diversity mode

Test Number	$\frac{DPCH - E_c}{I_{or}}$ (see note)	BLER
1	-18,0 dB	10^{-2}
2	-18,3 dB	10^{-2}
NOTE: This is the total power from both antennas. Power sharing between antennas are closed loop mode dependent as specified in TS 25.214 [5].		

The reference for this requirement is TS 25.101 [1] clause 8.6.2.1.

7.6.2.3 Test purpose

To verify that UE reliably demodulates the DPCH of the Node B while closed loop transmit diversity is enabled during the connection.

7.6.2.4 Method of test

7.6.2.4.1 Initial conditions

Test environment: normal; see clauses G.2.1 and G.2.2.

Frequencies to be tested: mid range; see clause G.2.4.

- 1) Connect SS, multi-path fading simulators and an AWGN source to the UE antenna connector as shown in figure A.12.
- 2) Set up a call according to the Generic call setup procedure.
- 3) RF parameters are set up according to table 7.6.2.1 and table E 3.5.
- 4) Enter the UE into loopback test mode and start the loopback test.
- 5) Activate closed loop Tx diversity function.
- 6) Set up fading simulators as fading condition case 1, which is described in table D.2.2.1.

See TS 34.108 [3] and TS 34.109 [4] for details regarding generic call setup procedure and loopback test.

7.6.2.4.2 Procedure

- 1) Measure BLER in points specified in table 7.6.2.2.

7.6.2.5 Test Requirements

For the parameters specified in table 7.6.2.3 the average downlink $\frac{DPCH - E_c}{I_{or}}$ power ratio shall be below the specified value for the BLER shown in table 7.6.2.4.

Table 7.6.2.3: Test Parameters for DCH Reception in closed loop transmit diversity mode (Propagation condition: Case 1)

Parameter	Test 1 (Mode 1)	Test 2 (Mode 2)	Unit
\hat{I}_{or}/I_{oc}	9,8	9,8	dB
I_{oc}	-60	-60	dBm / 3,84 MHz
Information data rate	12,2	12,2	kbps
Feedback error ratio	4	4	%

Table 7.6.2.4: Test requirements for DCH reception in closed loop transmit diversity mode

Test Number	$\frac{DPCH_E_c}{I_{or}}$ (see note)	BLER
1	-17,9 dB	10^{-2}
2	-18,2 dB	10^{-2}
NOTE: This is the total power from both antennas. Power sharing between antennas are closed loop mode dependent as specified in TS 25.214 [5].		

NOTE: If the above Test Requirement differs from the Minimum Requirement then the Test Tolerance applied for this test is non-zero. The Test Tolerance for this test is defined in clause F.2 and the explanation of how the Minimum Requirement has been relaxed by the Test Tolerance is given in clause F.4.

7.6.3 Demodulation of DCH in Site Selection Diversity Transmission Power Control mode

7.6.3.1 Definition and applicability

The bit error characteristics of UE receiver is determined in Site Selection Diversity Transmission Power Control (SSDT) mode. Two Node B emulators are required for this performance test. The delay profiles of signals received from different base stations are assumed to be the same but time shifted by 10 chip periods.

The requirements and this test apply to all types of UTRA for the FDD UE.

7.6.3.2 Minimum requirements

The downlink physical channels and their relative power to I_{or} are the same as those specified in clause E.3.3 irrespective of Node Bs and the test cases. $DPCH_E_c/I_{or}$ value applies whenever DPDCH in the cell is transmitted. In Test 1 and Test 3, the received powers at UE from two Node Bs are the same, while 3dB offset is given to one that comes from one of Node Bs for Test 2 and Test 4 as specified in table 7.6.3.1.

For the parameters specified in table 7.6.3.1 the average downlink $\frac{DPCH_E_c}{I_{or}}$ power ratio shall be below the specified value for the BLER shown in table 7.6.3.2.

Table 7.6.3.1: DCH parameters in multi-path propagation conditions during SSDT mode (Propagation condition: Case 1)

Parameter	Test 1	Test 2	Test 3	Test 4	Unit
Phase reference	P-CPICH				
\hat{I}_{or1}/I_{oc}	0	-3	0	0	dB
\hat{I}_{or2}/I_{oc}	0	0	0	-3	dB
I_{oc}	-60				dBm / 3,84 MHz
Information Data Rate	12,2	12,2	12,2	12,2	kbps
Cell ID code word error ratio in uplink (note)	1	1	1	1	%
Number of FBI bits assigned to "S" Field	1	1	2	2	
Code word Set	Long	Long	Short	Short	
UL DPCCH slot Format	#2		#5		
NOTE: The code word errors are introduced independently in both uplink channels.					

Table 7.6.3.2: DCH requirements in multi-path propagation conditions during SSDT Mode

Test Number	$\frac{DPCH - E_c}{I_{or}}$	BLER
1	-7,5 dB	10^{-2}
2	-6,5 dB	10^{-2}
3	-10,5 dB	10^{-2}
4	-9,2 dB	10^{-2}

The reference for this requirement is TS 25.101 [1] clause 8.6.3.1.

7.6.3.3 Test purpose

To verify that UE reliably demodulates the DPCH of the selected Node B while site selection diversity is enabled during soft handover.

7.6.3.4 Method of test

7.6.3.4.1 Initial conditions

Test environment: normal; see clauses G.2.1 and G.2.2.

Frequencies to be tested: mid range; see clause G.2.4.

- 1) Connect two SS's, multi-path fading simulators and an AWGN source to the UE antenna connector as shown in figure A.11.
- 2) Set up a call according to the Generic call setup procedure, and RF parameters are set up according to table 7.6.3.3 and table 7.6.3.4.
- 3) Enter the UE into loopback test mode and start the loopback test.
- 4) Activate SSDT function.
- 5) Set up fading simulators as fading condition case 1, which is described in table D.2.2.1.

7.6.3.4.2 Procedure

Measure BLER in points specified in table 7.6.3.4.

7.6.3.5 Test Requirements

For the parameters specified in table 7.6.3.3 the average downlink $\frac{DPCH - E_c}{I_{or}}$ power ratio shall be below the specified value for the BLER shown in table 7.6.3.4.

**Table 7.6.3.3: DCH parameters in multi-path propagation conditions during SSDT mode
(Propagation condition: Case 1)**

Parameter	Test 1	Test 2	Test 3	Test 4	Unit
Phase reference	P-CPICH				
\hat{I}_{or1}/I_{oc}	0,8	-2,2	0,8	0,8	dB
\hat{I}_{or2}/I_{oc}	0,8	0,8	0,8	-2,2	dB
I_{oc}	-60				dBm / 3,84 MHz
Information Data Rate	12,2	12,2	12,2	12,2	kbps
Cell ID code word error ratio in uplink (note)	1	1	1	1	%
Number of FBI bits assigned to "S" Field	1	1	2	2	
Code word Set	Long	Long	Short	Short	
UL DPCCH slot Format	#2		#5		
NOTE:	The code word errors are introduced independently in both uplink channels.				

Table 7.6.3.4: DCH requirements in multi-path propagation conditions during SSDT Mode

Test Number	$\frac{DPCH_E_c}{I_{or}}$	BLER
1	-7,4 dB	10^{-2}
2	-6,4 dB	10^{-2}
3	-10,4 dB	10^{-2}
4	-9,1 dB	10^{-2}

NOTE: If the above Test Requirement differs from the Minimum Requirement then the Test Tolerance applied for this test is non-zero. The Test Tolerance for this test is defined in clause F.2 and the explanation of how the Minimum Requirement has been relaxed by the Test Tolerance is given in clause F.4.

7.7 Demodulation in Handover conditions

7.7.1 Demodulation of DCH in Inter-Cell Soft Handover

7.7.1.1 Definition and applicability

The bit error ratio characteristics of UE is determined during an inter-cell soft handover. During the soft handover a UE receives signals from different Base Stations. A UE has to be able to demodulate two P-CCPCH channels and to combine the energy of DCH channels. Delay profiles of signals received from different Base Stations are assumed to be the same but time shifted by 10 chips.

The receive characteristics of the different channels during inter-cell handover are determined by the Block Error Ratio (BLER) values.

The UE shall be tested only according to the data rate, supported. The data-rate-corresponding requirements shall apply to the UE.

7.7.1.2 Minimum requirements

For the parameters specified in table 7.7.1.1 the average downlink $\frac{DPCH_E_c}{I_{or}}$ power ratio shall be below the specified value for the BLER shown in table 7.7.1.2.

Table 7.7.1.1: DCH parameters in multi-path propagation conditions during Soft Handoff (Case 3)

Parameter	Test 1	Test 2	Test 3	Test 4	Unit
Phase reference	P-CPICH				
\hat{I}_{or1}/I_{oc} and \hat{I}_{or2}/I_{oc}	0	0	3	6	dB
I_{oc}	-60				dBm / 3,84 MHz
Information Data Rate	12,2	64	144	384	kbps

Table 7.7.1.2: DCH requirements in multi-path propagation conditions during Soft Handoff (Case 3)

Test Number	$\frac{DPCH_E_c}{I_{or}}$	BLER
1	-15,2 dB	10^{-2}
2	-11,8 dB	10^{-1}
	-11,3 dB	10^{-2}
3	-9,6 dB	10^{-1}
	-9,2 dB	10^{-2}
4	-6,0 dB	10^{-1}
	-5,5 dB	10^{-2}

The reference for this requirement is TS 25.101 [1] clause 8.7.1.1.

7.7.1.3 Test purpose

To verify that the BLER does not exceed the value at the $DPCH_E_c/I_{or}$ specified in table 7.7.1.2.

7.7.1.4 Method of test

7.7.1.4.1 Initial conditions

Test environment: normal; see clauses G.2.1 and G.2.2.

Frequencies to be tested: mid range; see clause G.2.4.

[TBD]

7.7.1.4.2 Procedures

- 1) Connect the SS, multi-path fading simulator and an AWGN noise source to the UE antenna connector as shown in figure A.11.
- 2) Set up the call.
- 3) Set the test parameters for test 1-4 as specified in table 7.7.1.3.
- 4) Count, at the SS, the number of information blocks transmitted and the number of correctly received information blocks at the UE.
- 5) Measure BLER of DCH channel.

7.7.1.5 Test requirements

For the parameters specified in table 7.7.1.3 the average downlink $\frac{DPCH_E_c}{I_{or}}$ power ratio shall be below the specified value for the BLER shown in table 7.7.1.4.

Table 7.7.1.3: DCH parameters in multi-path propagation conditions during Soft Handoff (Case 3)

Parameter	Test 1	Test 2	Test 3	Test 4	Unit
Phase reference	P-CPICH				
\hat{I}_{or1}/I_{oc} and \hat{I}_{or2}/I_{oc}	0,8	0,8	3,8	6,8	dB
I_{oc}	-60				dBm / 3,84 MHz
Information Data Rate	12,2	64	144	384	kbps

Table 7.7.1.4: DCH requirements in multi-path propagation conditions during Soft Handoff (Case 3)

Test Number	$\frac{DPCH - E_c}{I_{or}}$	BLER
1	-15,1 dB	10^{-2}
2	-11,7 dB	10^{-1}
	-11,2 dB	10^{-2}
3	-9,5 dB	10^{-1}
	-9,1 dB	10^{-2}
4	-5,9 dB	10^{-1}
	-5,4 dB	10^{-2}

NOTE: If the above Test Requirement differs from the Minimum Requirement then the Test Tolerance applied for this test is non-zero. The Test Tolerance for this test is defined in clause F.2 and the explanation of how the Minimum Requirement has been relaxed by the Test Tolerance is given in clause F.4.

7.7.2 Combining of TPC commands from radio links of different radio link sets

7.7.2.1 Definition and applicability

When a UE is in soft handover, multiple TPC commands may be received in each slot from different cells in the active set. In general, the TPC commands transmitted in the same slot in the different cells may be different and need to be combined to give TPC_cmd as specified in TS 25.214 [5], in order to determine the required uplink power step.

The requirements and this test apply to all types of UTRA for the FDD UE.

7.7.2.2 Minimum requirements

Test parameters are specified in table 7.7.2.1. The delay profiles of the signals received from the different cells are the same but time-shifted by 10 chips.

For Test 1, the sequence of uplink power changes between adjacent slots shall be as shown in table 7.7.2.2 over the 4 consecutive slots more than 99% of the time. Note that this case is without an additional noise source I_{oc} .

For Test 2, the Cell1 and Cell2 TPC patterns are repeated a number of times. If the transmitted power of a given slot is increased compared to the previous slot, then a variable "Transmitted power UP" is increased by one, otherwise a variable "Transmitted power DOWN" is increased by one. The requirements for "Transmitted power UP" and "Transmitted power DOWN" are shown in table 7.7.2.3.

Table 7.7.2.1: Parameters for TPC command combining

Parameter	Test 1	Test 2	Unit
Phase reference	P-CPICH		-
DPCH_Ec/I _{or}	-12		dB
\hat{I}_{or1} and \hat{I}_{or2}	-60		dBm / 3,84 MHz
I_{oc}	-	-60	dBm / 3,84 MHz
Power-Control-Algorithm	Algorithm 1		-
Cell 1 TPC commands over 4 slots	{0,0,1,1}		-
Cell 2 TPC commands over 4 slots	{0,1,0,1}		-
Information Data Rate	12,2		Kbps
Propagation condition	Static without AWGN source I_{oc}	Multi-path fading case 3	-

Table 7.7.2.2: Requirements for Test 1

Test Number	Required power changes over the 4 consecutive slots
1	Down, Down, Down, Up

Table 7.7.2.3: Requirements for Test 2

Test Number	Ratio (Transmitted power UP) / (Total number of slots)	Ratio (Transmitted power DOWN) / (Total number of slots)
2	≥0,25	≥0,5

The reference for this requirement is TS 25.101 [1] clause 8.7.2.1.

7.7.2.3 Test purpose

To verify that the combining of TPC commands received in soft handover results in TPC_cmd being derived so as to meet the requirements stated in tables 7.7.2.2 and 7.7.2.3.

7.7.2.4 Method of test

7.7.2.4.1 Initial conditions

Test environment: normal; see clauses G.2.1 and G.2.2.

Frequencies to be tested: mid range; see clause G.2.4.

- 1) Connect two SS's to the UE antenna connector as shown in figure A.13.
- 2) Set the test parameters as specified in table 7.7.2.4 for Test 1.
- 3) Set up a call according to the Generic Call Setup procedure.
- 4) Signal the uplink DPCH power control parameters to use Algorithm 1 and a step size of 1dB.
- 5) Enter the UE into loopback test mode and start the loopback test.

See TS 34.108 [3] and TS 34.109 [4] for details regarding the generic call setup procedure and loopback test.

Table 7.7.2.4: Parameters for TPC command combining

Parameter	Test 1	Test 2	Unit
Phase reference	P-CPICH		-
DPCH_Ec/I _{or}	-11,9		dB
\hat{I}_{or1} and \hat{I}_{or2}	-60	-59.2	dBm / 3,84 MHz
I_{oc}	-	-60	dBm / 3,84 MHz
Power-Control-Algorithm	Algorithm 1		-
Cell 1 TPC commands over 4 slots	{0,0,1,1}		-
Cell 2 TPC commands over 4 slots	{0,1,0,1}		-
Information Data Rate	12,2		Kbps
Propagation condition	Static without AWGN source I_{oc}	Multi-path fading case 3	-

- 1) In Step 3) of clause 7.7.2.4.2, the mean power in slot #1 shall be less than or equal to the mean power in slot #0 minus 0,5 dB.
- 2) In Step 3) of clause 7.7.2.4.2, the mean power in slot #2 shall be less than or equal to the mean power in slot #1 minus 0,5 dB.
- 3) In Step 3) of clause 7.7.2.4.2, the mean power in slot #3 shall be less than or equal to the mean power in slot #2 minus 0,5 dB.
- 4) In Step 3) of clause 7.7.2.4.2, the mean power in slot #4 shall be greater than or equal to the mean power in slot #3 plus 0,5 dB.
- 5) The sequence of test requirements 1-4 shall be fulfilled more than 99% of the time.
- 6) At the end of the test, "Transmitted power UP" shall be greater than or equal to [95] and "Transmitted power DOWN" shall be greater than or equal to [210].

NOTE 1: The test limits in requirement (6) have been computed to give a confidence level of [99,7] % that a UE which follows the core requirements will pass. The number of timeslots has been chosen to get a good compromise between the test time and the risk of passing a bad UE.

NOTE 2: If the above Test Requirement differs from the Minimum Requirement then the Test Tolerance applied for this test is non-zero. The Test Tolerance for this test is defined in clause F.2 and the explanation of how the Minimum Requirement has been relaxed by the Test Tolerance is given in clause F.4.

7.8 Power control in downlink

Power control in the downlink is the ability of the UE receiver to converge to required link quality set by the network while using as low power as possible in downlink. If a BLER target has been assigned to a DCCH (See clause C.3), then it has to be such that outer loop is based on DTCH and not on DCCH.

7.8.1 Power control in the downlink, constant BLER target

7.8.1.1 Definition and applicability

Power control in the downlink is the ability of the UE receiver to converge to required link quality set by the network while using as low power as possible in downlink. If a BLER target has been assigned to a DCCH (See clause C.3), then it has to be such that outer loop is based on DTCH and not on DCCH. The requirements and this test apply to all types of UTRA for the FDD UE.

7.8.1.2 Minimum requirements

For the parameters specified in table 7.8.1.1 the downlink $\frac{DPCH_E_c}{I_{or}}$ power ratio measured values, which are averaged over one slot, shall be below the specified value in table 7.8.1.2 more than 90% of the time. BLER shall be as shown in table 7.8.1.2. Power control in downlink is ON during the test.

Table 7.8.1.1: Test parameter for downlink power control, constant BLER target

Parameter	Test 1	Test 2	Unit
\hat{I}_{or}/I_{oc}	9	-1	dB
I_{oc}	-60		dBm / 3,84 MHz
Information Data Rate	12,2		kbps
Target quality on DTCH	0,01		BLER
Propagation condition	Case 4		
Maximum_DL_Power (note)	7		dB
Minimum_DL_Power (note)	-18		dB
DL Power Control step size, Δ_{TPC}	1		dB
Limited Power Increase	"Not used"		-
NOTE: Power is compared to P-CPICH as specified in [9].			

Table 7.8.1.2: Requirements in downlink power control, constant BLER target

Parameter	Test 1	Test 2	Unit
$\frac{DPCH_E_c}{I_{or}}$	-16,0	-9,0	dB
Measured quality on DTCH	0,01 ± 30 %	0,01 ± 30 %	BLER

The reference for this requirement is TS 25.101 [1] clause 8.8.1.1.

7.8.1.3 Test purpose

To verify that the UE receiver is capable of converging to required link quality set by network while using as low power as possible.

7.8.1.4 Method of test

7.8.1.4.1 Initial conditions

Test environment: normal; see clauses G.2.1 and G.2.2.

Frequencies to be tested: mid range; see clause G.2.4.

- 1) Connect SS, multipath fading simulator and an AWGN source to the UE antenna connector as shown in figure A.10.
- 2) Set up a call according to the Generic call setup procedure.
- 3) RF parameters are set up according to table 7.8.1.3.
- 4) Enter the UE into loopback test mode and start the loopback test.
- 5) SS signals to UE target quality value on DTCH as specified in table 7.8.1.3. SS will vary the physical channel power in downlink according to the TPC commands from UE. Downlink power control mode (DPC_MODE) 0 shall be used. At the same time BLER is measured. This is continued until the target quality value on DTCH is met, within the minimum accuracy requirement.

See TS 34.108 [3] and TS 34.109 [4] for details regarding generic call setup procedure and loopback test.

7.8.1.4.2 Procedure

- 1) After the target quality on DTCH is met, BLER is measured. Simultaneously the downlink $\frac{DPCH - E_c}{I_{or}}$ power ratio averaged over one slot is measured. This is repeated until adequate amount of measurements is done to reach the required confidence level.
- 2) The measured quality on DTCH (BLER) and the measured downlink $\frac{DPCH - E_c}{I_{or}}$ power ratio values averaged over one slot are compared to limits in table 7.8.1.2.

7.8.1.5 Test Requirements

The test parameters are specified in table 7.8.1.3.

Table 7.8.1.3: Test parameter for downlink power control, constant BLER target

Parameter	Test 1	Test 2	Unit
\hat{I}_{or}/I_{oc}	9,6	-0,4	dB
I_{oc}	-60		dBm / 3,84 MHz
Information Data Rate	12,2		kbps
Target quality on DTCH	0,01		BLER
Propagation condition	Case 4		
Maximum_DL_Power (note)	7		dB
Minimum_DL_Power (note)	-18		dB
DL Power Control step size, Δ_{TPC}	1		dB
Limited Power Increase	"Not used"		-
NOTE: Power is compared to P-CPICH as specified in [9].			

- a) The measured quality on DTCH does not exceed the values in table 7.8.1.4.
- b) The downlink $\frac{DPCH - E_c}{I_{or}}$ power ratio values, which are averaged over one slot, shall be below the values in table 7.8.1.4 more than 90 % of the time.

Table 7.8.1.4: Requirements in downlink power control, constant BLER target

Parameter	Test 1	Test 2	Unit
$\frac{DPCH - E_c}{I_{or}}$	-15,9	-8,9	dB
Measured quality on DTCH	0,01 ± 30 %	0,01 ± 30 %	BLER

NOTE: If the above Test Requirement differs from the Minimum Requirement then the Test Tolerance applied for this test is non-zero. The Test Tolerance for this test is defined in clause F.2 and the explanation of how the Minimum Requirement has been relaxed by the Test Tolerance is given in clause F.4.

7.8.2 Power control in the downlink, initial convergence

7.8.2.1 Definition and applicability

This requirement verifies that DL power control works properly during the first seconds after DPCH connection is established. The requirements and this test apply to all types of UTRA for the FDD UE.

7.8.2.2 Minimum requirements

For the parameters specified in table 7.8.2.1 the downlink DPCH_Ec/Ior power ratio measured values, which are averaged over 50 ms, shall be within the range specified in table 7.8.2.2 more than 90 % of the time. T1 equals to 500 ms and it starts 10 ms after the DPDCH connection is initiated. T2 equals to 500 ms and it starts when T1 has expired. Power control is ON during the test.

The first 10 ms shall not be used for averaging, i.e. the first sample to be input to the averaging filter is at the beginning of T1. The averaging shall be performed with a sliding rectangular window averaging filter. The window size of the averaging filter is linearly increased from 0 up to 50 ms during the first 50 ms of T1, and then kept equal to 50ms.

Table 7.8.2.1: Test parameters for downlink power control, initial convergence

Parameter	Test 1	Test 2	Test 3	Test 4	Unit
Target quality value on DTCH	0,01	0,01	0,1	0,1	BLER
Initial DPCH_Ec/Ior	-5,9	-25,9	-3	-22,1	dB
Information Data Rate	12,2	12,2	64	64	kbps
\hat{I}_{or}/I_{oc}	-1				dB
I_{oc}	-60				dBm/3,84 MHz
Propagation condition	Static				
Maximum_DL_Power (note)	7				dB
Minimum_DL_Power (note)	-18				dB
DL Power Control step size, Δ_{TPC}	1				dB
Limited Power Increase	"Not used"				
NOTE: Power is compared to P-CPICH as specified in [9].					

Table 7.8.2.2: Requirements in downlink power control, initial convergence

Parameter	Test 1 and Test 2	Test 3 and Test 4	Unit
$\frac{DPCH_E_c}{I_{or}}$ during T1	$-18,9 \leq DPCH_Ec/Ior \leq -11,9$	$-15,1 \leq DPCH_Ec/Ior \leq -8,1$	dB
$\frac{DPCH_E_c}{I_{or}}$ during T2	$-18,9 \leq DPCH_Ec/Ior \leq -14,9$	$-15,1 \leq DPCH_Ec/Ior \leq -11,1$	dB

The reference for this requirement is TS 25.101 [1] clause 8.8.2.1.

7.8.2.3 Test purpose

To verify that DL power control works properly during the first seconds after DPCH connection is established.

7.8.2.4 Method of test

7.8.2.4.1 Initial conditions

Test environment: normal; see clauses G.2.1 and G.2.2.

Frequencies to be tested: mid range; see clause G.2.4.

- 1) Connect SS, multipath fading simulator and an AWGN source to the UE antenna connector as shown in figure A.10.

7.8.2.4.2 Procedure

- 1) Set up call using test parameters according to table 7.8.2.1.

- 2) SS signals to UE target quality value on DTCH as specified in table 7.8.2.3. SS will vary the physical channel power in downlink according to the TPC commands from UE. Downlink power control mode (DPC_MODE) 0 shall be used.
- 3) Measure $\frac{DPCH_{-}E_c}{I_{or}}$ power ratio averaged over 50 ms during T1. T1 starts 10 ms after DPDCH connection is initiated and T1 equals to 500 ms. The first 10 ms shall not be used for averaging, i.e. the first sample to be input to the averaging filter is at the beginning of T1. The averaging shall be performed with a sliding rectangular window averaging filter. The window size of the averaging filter is linearly increased from 0 up to 50 ms during the first 50 ms of T1, and then kept equal to 50ms.
- 4) Measure $\frac{DPCH_{-}E_c}{I_{or}}$ power ratio averaged over 50 ms during T2. T2 starts, when T1 has expired and T2 equals to 500 ms.

7.8.2.5 Test Requirements

The test parameters are specified in table 7.8.2.3.

Table 7.8.2.3: Test parameters for downlink power control, initial convergence

Parameter	Test 1	Test 2	Test 3	Test 4	Unit
Target quality value on DTCH	0,01	0,01	0,1	0,1	BLER
Initial DPCH_Ec/lor	-5,9	-25,9	-3	-22,1	dB
Information Data Rate	12,2	12,2	64	64	kbps
\hat{I}_{or}/I_{oc}	-0,4				dB
I_{oc}	-60				dBm/3,84 MHz
Propagation condition	Static				
Maximum_DL_Power (note)	7				dB
Minimum_DL_Power (note)	-18				dB
DL Power Control step size, Δ_{TPC}	1				dB
Limited Power Increase	"Not used"				
NOTE: Power is compared to P-CPICH as specified in [9].					

- a) The downlink $\frac{DPCH_{-}E_c}{I_{or}}$ power ratio values shall be within the range specified in table 7.8.2.4 during T1 more than 90 % of the time.
- b) The downlink $\frac{DPCH_{-}E_c}{I_{or}}$ power ratio values shall be within the range specified in table 7.8.2.4 during T2 more than 90 % of the time.

Table 7.8.2.4: Requirements in downlink power control, initial convergence

Parameter	Test 1 and Test 2	Test 3 and Test 4	Unit
$\frac{DPCH_{-}E_c}{I_{or}}$ during T1	$-18,8 \leq DPCH_Ec/lor \leq -11,8$	$-15,0 \leq DPCH_Ec/lor \leq -8,0$	dB
$\frac{DPCH_{-}E_c}{I_{or}}$ during T2	$-18,8 \leq DPCH_Ec/lor \leq -14,8$	$-15,0 \leq DPCH_Ec/lor \leq -11,0$	dB

NOTE: If the above Test Requirement differs from the Minimum Requirement then the Test Tolerance applied for this test is non-zero. The Test Tolerance for this test is defined in clause F.2 and the explanation of how the Minimum Requirement has been relaxed by the Test Tolerance is given in clause F.4.

7.8.3 Power control in the downlink, wind up effects

7.8.3.1 Definition and applicability

This requirement verifies that, after the downlink maximum power is limited in the UTRAN and it has been released again, the downlink power control in the UE does not have a wind up effect, i.e. the required DL power has increased during time period the DL power was limited. The requirements and this test apply to all types of UTRA for the FDD UE.

7.8.3.2 Minimum requirements

This test is run in three stages where stage 1 is for convergence of the power control loop, in stage two the maximum downlink power for the dedicated channel is limited not to be higher than the parameter specified in table 7.8.3.1. All parameters used in the three stages are specified in table 7.8.3.1. The downlink $\frac{DPCH_E_c}{I_{or}}$ power ratio measured values, which are averaged over one slot, during stage 3 shall be lower than the value specified in table 7.8.3.2 more than 90 % of the time. Power control of the UE is ON during the test.

Table 7.8.3.1: Test parameter for downlink power control, wind-up effects

Parameter	Test 1			Unit
	Stage 1	Stage 2	Stage 3	
Time in each stage	>15	5	0,5	s
\hat{I}_{or}/I_{oc}	5			dB
I_{oc}	-60			dBm/3,84 MHz
Information Data Rate	12,2			kbps
Quality target on DTCH	0,01			BLER
Propagation condition	Case 4			
Maximum_DL_Power (note)	7	-6,2	7	dB
Minimum_DL_Power (note)	-18			dB
DL Power Control step size, Δ_{TPC}	1			dB
Limited Power Increase	"Not used"			-
NOTE: Power is compared to P-CPICH as specified in [9].				

Table 7.8.3.2: Requirements in downlink power control, wind-up effects

Parameter	Test 1, stage 3	Unit
$\frac{DPCH_E_c}{I_{or}}$	-13,3	dB

The reference for this requirement is TS 25.101 [1] clause 8.8.3.1.

7.8.3.3 Test purpose

To verify that the UE downlink power control does not require too high downlink power during a period after the downlink power is limited by the UTRAN.

7.8.3.4 Method of test

7.8.3.4.1 Initial conditions

Test environment: normal; see clauses G.2.1 and G.2.2.

Frequencies to be tested: mid range; see clause G.2.4.

- 1) Connect SS, multipath fading simulator and an AWGN source to the UE antenna connector as shown in figure A.10.
- 2) Set up a call according to the Generic call setup procedure.
- 3) Enter the UE into loopback test mode and start the loopback test.
- 4) RF parameters are set up according to table 7.8.3.3. Stage 1 is used for the power control to converge and during Stage 2 the maximum downlink power is limited by UTRAN.
- 5) SS signals to UE target quality value on DTCH as specified in table 7.8.3.1. SS will vary the physical channel power in downlink according to the TPC commands from UE. Downlink power control mode (DPC_MODE) 0 shall be used.

See TS 34.108 [3] and TS 34.109 [4] for details regarding generic call setup procedure and loopback test.

7.8.3.4.2 Procedure

- 1) Measure $\frac{DPCH_E_c}{I_{or}}$ power ratio during stage 3 according to table 7.8.3.3.

7.8.3.5 Test Requirements

The test parameters are specified in table 7.8.3.3.

Table 7.8.3.3: Test parameter for downlink power control, wind-up effects

Parameter	Test 1			Unit
	Stage 1	Stage 2	Stage 3	
Time in each stage	>15	5	0,5	s
\hat{I}_{or}/I_{oc}	5,6			dB
I_{oc}	-60			dBm/3,84 MHz
Information Data Rate	12,2			kbps
Quality target on DTCH	0,01			BLER
Propagation condition	Case 4			
Maximum_DL_Power (note)	7	-6,2	7	dB
Minimum_DL_Power (note)	-18			dB
DL Power Control step size, Δ_{TPC}	1			dB
Limited Power Increase	"Not used"			-
NOTE: Power is compared to P-CPICH as specified in [9].				

The downlink $\frac{DPCH_E_c}{I_{or}}$ power ratio values, which are averaged over one slot, shall be lower than the level specified in table 7.8.3.4 during stage 3 more than 90 % of the time.

Table 7.8.3.4: Requirements in downlink power control, wind-up effects

Parameter	Test 1, stage 3	Unit
$\frac{DPCH_E_c}{I_{or}}$	-13,2	dB

NOTE: If the above Test Requirement differs from the Minimum Requirement then the Test Tolerance applied for this test is non-zero. The Test Tolerance for this test is defined in clause F.2 and the explanation of how the Minimum Requirement has been relaxed by the Test Tolerance is given in clause F.4.

7.9 Downlink compressed mode

Downlink compressed mode is used to create gaps in the downlink transmission, to allow the UE to make measurements on other frequencies.

7.9.1 Single link performance

7.9.1.1 Definition and applicability

The receiver single link performance of the Dedicated Traffic Channel (DCH) in compressed mode is determined by the Block Error Ratio (BLER) and transmitted DPCH_Ec/I_{or} power ratio in the downlink.

The compressed mode parameters are given in clause C.5. Tests 1 and 2 are using Set 1 compressed mode pattern parameters from table C.5.1 in clause C.5 while tests 3 and 4 are using Set 2 compressed mode patterns from the same table.

The requirements and this test apply to all types of UTRA for the FDD UE.

7.9.1.2 Minimum requirements

For the parameters specified in table 7.9.1 the downlink $\frac{DPCH - E_c}{I_{or}}$ power ratio measured values, which are averaged over one slot, shall be below the specified value in table 7.9.2 more than 90% of the time. The measured quality on DTCH shall be as required in table 7.9.2.

Downlink power control is ON during the test. Uplink TPC commands shall be error free. System simulator shall increase the transmitted power during compressed frames by the same amount that UE is expected to increase its SIR target during those frames.

Table 7.9.1: Test parameter for downlink compressed mode

Parameter	Test 1	Test 2	Test 3	Test 4	Unit
Delta SIR1	0	3	0	3	dB
Delta SIR after1	0	3	0	3	dB
Delta SIR2	0	0	0	0	dB
Delta SIR after2	0	0	0	0	dB
\hat{I}_{or}/I_{oc}	9				dB
I_{oc}	-60				dBm / 3,84 MHz
Information Data Rate	12,2				kbps
Propagation condition	Case 2				
Target quality value on DTCH	0,01				BLER
Maximum DL Power (note)	7				dB
Minimum DL Power (note)	-18				dB
DL Power Control step size, Δ_{TPC}	1				dB
Limited Power Increase	"Not used"				-
NOTE: Power is compared to P-CPICH as specified in [9].					

Table 7.9.2: Requirements in downlink compressed mode

Parameter	Test 1	Test 2	Test 3	Test 4	Unit
$\frac{DPCH - E_c}{I_{or}}$	-14,6	No requirements	-15,2	No requirements	dB
Measured quality of compressed and recovery frames	No requirements	< 0,001	No requirements	< 0,001	BLER
Measured quality on DTCH	0,01 ± 30 %				BLER

The reference for this requirement is TS 25.101 [1] clause 8.9.1.1.

7.9.1.3 Test purpose

The purpose of this test is to verify the reception of DPCH in a UE while downlink is in a compressed mode. The UE needs to preserve the BLER using sufficient low DL power. It is also verified that UE applies the Delta SIR values, which are signaled from network, in its outer loop power control algorithm.

7.9.1.4 Method of test

7.9.1.4.1 Initial conditions

Test environment: normal; see clauses G.2.1 and G.2.2.

Frequencies to be tested: mid range; see clause G.2.4.

- 1) Connect SS, multipath fading simulator and an AWGN source to the UE antenna connector as shown in figure A.10.
- 2) Set up a call according to the Generic call setup procedure.
- 3) RF parameters are set up according to table 7.9.1. SS shall increase the transmitted power during compressed mode frames by the same amount that UE is expected to increase its SIR target during those frames.
- 4) Set compressed mode parameters according to table C.5.1. Tests 1 and 2 are using Set 1 compressed mode pattern parameters and while tests 3 and 4 are using Set 2 compressed mode pattern parameters.
- 5) Enter the UE into loopback test mode and start the loopback test.
- 6) SS signals to UE target quality value on DTCH as specified in table 7.9.1. Uplink TPC commands shall be error free. SS will vary the physical channel power in downlink according to the TPC commands from UE. SS response time for UE TPC commands shall be one slot. At the same time BLER is measured. This is continued until the target quality value on DTCH is met, within the minimum accuracy requirement.

See TS 34.108 [3] and TS 34.109 [4] for details regarding generic call setup procedure and loopback test.

7.9.1.4.2 Procedure

- 1) Test 1: Measure quality on DTCH and $\frac{DPCH - E_c}{I_{or}}$ power ratio values averaged over one slot.
- 2) Test 2: Measure quality on DTCH and quality of compressed and recovery frames.
- 3) Test 3: Measure quality on DTCH and $\frac{DPCH - E_c}{I_{or}}$ power ratio values averaged over one slot.
- 4) Test 4: Measure quality on DTCH and quality of compressed and recovery frames.

7.9.1.5 Test requirements

The test parameters are specified in table 7.9.3.

Table 7.9.3: Test parameter for downlink compressed mode

Parameter	Test 1	Test 2	Test 3	Test 4	Unit
Delta SIR1	0	3	0	3	dB
Delta SIR after1	0	3	0	3	dB
Delta SIR2	0	0	0	0	dB
Delta SIR after2	0	0	0	0	dB
\hat{I}_{or}/I_{oc}	9,6				dB
I_{oc}	-60				dBm / 3,84 MHz
Information Data Rate	12,2				kbps
Propagation condition	Case 2				
Target quality value on DTCH	0,01				BLER
Maximum DL Power (note)	7				dB
Minimum DL Power (note)	-18				dB
DL Power Control step size, Δ_{TPC}	1				dB
Limited Power Increase	"Not used"				-
NOTE: Power is compared to P-CPICH as specified in [9].					

- a) Test 1: The downlink $\frac{DPCH - E_c}{I_{or}}$ power ratio values averaged over one slot shall be below the values in table 7.9.4 more than 90 % of the time. The measured quality on DTCH shall be as required in table 7.9.4.
- b) Test 2: Measured quality on DTCH and measured quality of compressed and recovery frames do not exceed the values in table 7.9.4.
- c) Test3: The downlink $\frac{DPCH - E_c}{I_{or}}$ power ratio values averaged over one slot shall be below the values in table 7.9.2 more than 90 % of the time. The measured quality on DTCH shall be as required in table 7.9.4.
- d) Test 4: Measured quality on DTCH and measured quality of compressed and recovery frames do not exceed the values in table 7.9.4.

Table 7.9.4: Requirements in downlink compressed mode

Parameter	Test 1	Test 2	Test 3	Test 4	Unit
$\frac{DPCH - E_c}{I_{or}}$	-14,5	No requirements	-15,1	No requirements	dB
Measured quality of compressed and recovery frames	No requirements	< 0,001	No requirements	< 0,001	BLER
Measured quality on DTCH	0,01 ± 30 %				BLER

NOTE: If the above Test Requirement differs from the Minimum Requirement then the Test Tolerance applied for this test is non-zero. The Test Tolerance for this test is defined in clause F.2 and the explanation of how the Minimum Requirement has been relaxed by the Test Tolerance is given in clause F.4.

7.10 Blind transport format detection

7.10.1 Definition and applicability

Performance of Blind transport format detection is determined by the Block Error Ratio (BLER) values and by the measured average transmitted $DPCH_{Ec}/I_{or}$ value.

7.10.2 Minimum requirements

For the parameters specified in table 7.10.1 the average downlink $\frac{DPCH_E_c}{I_{or}}$ power ratio shall be below the specified value for the BLER and FDR shown in table 7.10.2.

Table 7.10.1: Test parameters for Blind transport format detection

Parameter	Test 1	Test 2	Test 3	Test 4	Test 5	Test 6	Unit
\hat{I}_{or}/I_{oc}	-1			-3			dB
I_{oc}	-60						dBm / 3.84 MHz
Information Data Rate	12,2 (rate 1)	7,95 (rate 2)	1,95 (rate 3)	12,2 (rate 1)	7,95 (rate 2)	1,95 (rate 3)	kbps
propagation condition	static			multi-path fading case 3			-
TFCI	off						-

Table 7.10.2: The Requirements for DCH reception in Blind transport format detection

Test Number	$\frac{DPCH_E_c}{I_{or}}$	BLER	FDR
1	-17,7dB	10^{-2}	10^{-4}
2	-17,8dB	10^{-2}	10^{-4}
3	-18,4dB	10^{-2}	10^{-4}
4	-13,0dB	10^{-2}	10^{-4}
5	-13,2dB	10^{-2}	10^{-4}
6	-13,8dB	10^{-2}	10^{-4}
NOTE: The value of DPCH_Ec/I _{or} , I _{oc} , and I _{or} /I _{oc} are defined in case of DPCH is transmitted.			

NOTE: In the test, 9 deferent Transport Format Combinations (table 7.10.3) are sent during the call set up procedure, so that UE has to detect correct transport format in this 9 candidates.

Table.7.10.3: Transport format combinations informed during the call set up procedure in the test

	1	2	3	4	5	6	7	8	9
DTCH	12,2 k	10,2 k	7,95 k	7,4 k	6,7 k	5,9 k	5,15 k	4,75 k	1,95 k
DCCH					2,4 k				

7.10.3 Test purpose

To verify the ability of the blind transport format detection to receive a predefined test signal, representing a static propagation channel for the wanted and for the co-channel signals from serving and adjacent cells, with a block error ratio (BLER) and false transport format detection ratio (FDR) not exceeding a specified value.

To verify the ability of the blind transport format detection to receive a predefined test signal, representing a multi-path propagation channel for the wanted and for the co-channel signals from serving and adjacent cells, with a block error ratio (BLER) and false transport format detection ratio (FDR) not exceeding a specified value.

7.10.4 Method of test

7.10.4.1 Initial conditions

Test environment: normal; see clauses G.2.1 and G.2.2.

Frequencies to be tested: mid range; see clause G.2.4.

1. Connect the SS and AWGN noise source to the UE antenna connector as shown in figure A.9 in the case for test 1-3. Connect the SS, multipath fading simulator and an AWGN noise source to the UE antenna connector as shown in figure A.10 in the case of test 4-6.
2. Set up a call according to the Generic call setup procedure.
3. Set the test parameters for test 1-6 as specified table 7.10.4 and table 7.10.5.
4. Enter the UE into loopback test mode and start the loopback test.
5. In the case of test 4-6, Setup fading simulator as fading condition case 3 which are described in table D.2.2.1.

7.10.4.2 Procedure

Measure BLER and FDR of DCH.

7.10.5 Test requirements

The test parameters are specified in table 7.10.4.

Table 7.10.4: Test parameters for Blind transport format detection

Parameter	Test 1	Test 2	Test 3	Test 4	Test 5	Test 6	Unit
\hat{I}_{or}/I_{oc}	-0,7			-2,4			dB
I_{oc}	-60						dBm / 3.84 MHz
Information Data Rate	12,2 (rate 1)	7,95 (rate 2)	1,95 (rate 3)	12,2 (rate 1)	7,95 (rate 2)	1,95 (rate 3)	kbps
propagation condition	Static			multi-path fading case 3			-
TFCI	off						-

BLER and FDR shall not exceed the values at the DPCH_Ec/I_{or} specified in table 7.10.5.

Table 7.10.5: The Requirements for DCH reception in Blind transport format detection

Test Number	$\frac{DPCH_E_c}{I_{or}}$	BLER	FDR
1	-17,6dB	10^{-2}	10^{-4}
2	-17,7dB	10^{-2}	10^{-4}
3	-18,3dB	10^{-2}	10^{-4}
4	-12,9dB	10^{-2}	10^{-4}
5	-13,1dB	10^{-2}	10^{-4}
6	-13,7dB	10^{-2}	10^{-4}
NOTE: The value of DPCH_Ec/I _{or} , I _{oc} , and I _{or} /I _{oc} are defined in case of DPCH is transmitted.			

NOTE: In the test, 9 different Transport Format Combinations (table 7.10.3) are sent during the call set up procedure, so that UE has to detect correct transport format in this 9 candidates.

NOTE: If the above Test Requirement differs from the Minimum Requirement then the Test Tolerance applied for this test is non-zero. The Test Tolerance for this test is defined in clause F.2 and the explanation of how the Minimum Requirement has been relaxed by the Test Tolerance is given in clause F.4.

8 Requirements for support of RRM

8.1 General

8.2 Idle Mode Tasks

8.2.1 Cell Selection

Void.

8.2.2 Cell Re-Selection

8.2.2.1 Scenario 1: Single carrier case

8.2.2.1.1 Definition and applicability

The cell re-selection delay is defined as the time from a change of cell levels to the moment when this change makes the UE camp on a new cell, and starts to send preambles on the PRACH for the RRC CONNECTION REQUEST message to perform a Location Updating procedure (MM) or Routing Area Updating procedure (GMM) on the new cell.

The requirements and this test apply to the FDD UE.

8.2.2.1.2 Minimum requirement

The cell re-selection delay shall be less than 8 s with a DRX cycle length of 1.28 s.

The rate of correct cell reselections observed during repeated tests shall be at least 90% with a confidence level of [FFS]%.
 NOTE: The cell re-selection delay can be expressed as: $T_{\text{evaluateFDD}} + T_{\text{SI}}$, where:

$T_{\text{evaluateFDD}}$	See table 4.1 in TS 25.133 [2] clause 4.2.2.
T_{SI}	Maximum repetition period of relevant system info blocks that needs to be received by the UE to camp on a cell. 1280 ms is assumed in this test case.

This gives a total of 7.68 s, allow 8s in the test case.

The normative reference for this requirement is TS 25.133 [2] clauses 4.2.2.2 and A.4.2.1.

8.2.2.1.3 Test purpose

To verify that the UE meets the minimum requirement.

8.2.2.1.4 Method of test

8.2.2.1.4.1 Initial conditions

Test environment: normal; see clauses G.2.1 and G.2.2.

Frequencies to be tested: mid range; see clause G.2.4.

This scenario implies the presence of 1 carrier and 6 cells as given in tables 8.2.2.1.1 and 8.2.2.1.2. The UE is requested to monitor neighbouring cells on 1 carrier. The maximum repetition period of the relevant system info blocks that needs to be received by the UE to camp on a cell shall be 1 280 ms. Cell 1 and cell 2 shall belong to different Location Areas.

Table 8.2.2.1.1: Scenario 1: General test parameters for Cell Re-selection single carrier multi-cell case

Parameter		Unit	Value	Comment
Initial condition	Active cell		Cell2	
	Neighbour cells		Cell1, Cell3, Cell4, Cell5, Cell6	
Final condition	Active cell		Cell1	
SYSTEM INFORMATION BLOCK TYPE 1 - CN common GSM-MAP NAS system information		-	00 80(H) → Cell 1 00 81(H) → Cell 2	This identity should be set as different value from the neighbour cell so that a Location Updating procedure(MM) or a Routing Area Updating procedure(GMM) is performed when UE selects more suitable cell in idle state.
Access Service Class (ASC#0) - Persistence value		-	1	Selected so that no additional delay is caused by the random access procedure. The value shall be used for all cells in the test.
HCS				Not used
DRX cycle length		s	1,28	The value shall be used for all cells in the test.
T1		s	15	T1 need to be defined so that cell re-selection reaction time is taken into account.
T2		s	15	T2 need to be defined so that cell re-selection reaction time is taken into account.

Table 8.2.2.1.2: Scenario 1: Test parameters for Cell re-selection single carrier multi cell, initial conditions

Parameter	Unit	Cell 1		Cell 2		Cell 3		Cell 4		Cell 5		Cell 6	
		T1	T2	T1	T2	T1	T2	T1	T2	T1	T2	T1	T2
UTRA RF Channel Number		Channel 1		Channel 1		Channel 1		Channel 1		Channel 1		Channel 1	
CPICH_Ec/Ior	dB	-10		-10		-10		-10		-10		-10	
PCCPCH_Ec/Ior	dB	-12		-12		-12		-12		-12		-12	
SCH_Ec/Ior	dB	-12		-12		-12		-12		-12		-12	
PICH_Ec/Ior	dB	-15		-15		-15		-15		-15		-15	
OCNS_Ec/Ior	dB	-0,941		-0,941		-0,941		-0,941		-0,941		-0,941	
\hat{I}_{or}/I_{oc}	dB	7,3	10,27	10,27	7,3	0,27		0,27		0,27		0,27	
I_{oc}	dBm / 3,84 MHz	-70											
CPICH_Ec/Io	dB	-16	-13	-13	-16	-23		-23		-23		-23	
Propagation Condition		AWGN											
Cell_selection_and_reselection_quality_measure		CPICH E _c /N ₀		CPICH E _c /N ₀		CPICH E _c /N ₀		CPICH E _c /N ₀		CPICH E _c /N ₀		CPICH E _c /N ₀	
Qqualmin	dB	-20		-20		-20		-20		-20		-20	
Qrxlevmin	dBm	-115		-115		-115		-115		-115		-115	
UE_TXPWR_MAX_RACH	dB	21		21		21		21		21		21	
Qoffset _{s, n}	dB	C1, C2: 0 C1, C3: 0 C1, C4: 0 C1, C5: 0 C1, C6: 0		C2, C1: 0 C2, C3: 0 C2, C4: 0 C2, C5: 0 C2, C6: 0		C3, C1: 0 C3, C2: 0 C3, C4: 0 C3, C5: 0 C3, C6: 0		C4, C1: 0 C4, C2: 0 C4, C3: 0 C4, C5: 0 C4, C6: 0		C5, C1: 0 C5, C2: 0 C5, C3: 0 C5, C4: 0 C5, C6: 0		C6, C1: 0 C6, C2: 0 C6, C3: 0 C6, C4: 0 C6, C5: 0	
Qhyst2	dB	0		0		0		0		0		0	
Treselection	s	0		0		0		0		0		0	
Sintrasearch	dB	not sent		not sent		not sent		not sent		not sent		not sent	

8.2.2.1.4.2 Procedure

- 1) The SS activates cell 1-6 with T1 defined parameters in table 8.2.2.1.2 and monitors cell 1 and 2 for random access requests from the UE.
- 2) The UE is switched on.
- 3) The SS and the UE shall perform a first registration procedure on cell2.
- 4) 15 s after step3 has completed, the parameters are changed to that as described for T2 in table 8.2.2.1.2.
- 5) The SS waits for random access requests from the UE. If the UE responds on cell 1 within 8 s from the beginning of time period T2 then the number of successful tests is increased by one. The SS and the UE shall perform a Location Updating procedure (MM) or a Routing Area Updating procedure (GMM) on cell1.
- 6) After 15 s from the beginning of time period T2, the parameters are changed to that as described for T1 in table 8.2.2.1.2.
- 7) The SS waits for random access requests from the UE. If the UE responds on cell 2 within 8 s from the beginning of time period T1 then the number of successful tests is increased by one. The SS and the UE shall perform a Location Updating procedure(MM) or a Routing Area Updating procedure (GMM) on cell2.
- 8) After 15 s from the beginning of time period T1, the parameters are changed to that as described for T2.
- 9) Repeat step 5) to 8) [TBD] times.

NOTE: The time required for receiving all the relevant system information data according to the reception procedure and the RRC procedure delay of system information blocks defined in 25.331 for a UTRAN cell. Since the maximum repetition period of the relevant system info blocks that needs to be received by the UE to camp on a cell is 1280ms and the maximum RRC procedure delay for reception system information block is 100ms, 1380 ms is assumed in this test case. Therefore this gives a total of 7.78s.(Minimum requirement + 100ms), allow 8s in the test case.

8.2.2.1.5 Test requirements

For the test to pass, the total number of successful attempts shall be more than 90% with a confidence level of [FFS]% of the cases.

NOTE: If the above Test Requirement differs from the Minimum Requirement then the Test Tolerance applied for this test is non-zero. The Test Tolerance for this test is defined in clause F.2 and the explanation of how the Minimum Requirement has been relaxed by the Test Tolerance is given in clause F.4.

8.2.2.2 Scenario 2: Multi carrier case

8.2.2.2.1 Definition and applicability

The cell re-selection delay is defined as the time from a change of cell levels to the moment when this change makes the UE camp on a new cell, and starts to send preambles on the PRACH for the RRC CONNECTION REQUEST message to perform a Location Updating procedure(MM) or Routing Area Updating procedure (GMM) on the new cell.

The requirements and this test apply to the FDD UE.

8.2.2.2.2 Minimum requirement

The cell re-selection delay shall be less than 8 s with a DRX cycle length of 1.28 s.

The rate of correct cell reselections observed during repeated tests shall be at least 90% with a confidence level of [FFS]%.

NOTE: The cell re-selection delay can be expressed as: $T_{\text{evaluateFDD}} + T_{\text{SI}}$, where:

$T_{\text{evaluateFDD}}$	See table 4.1 in TS 25.133 [2] clause 4.2.2.
T_{SI}	Maximum repetition period of relevant system info blocks that needs to be received by the UE to camp on a cell. 1280 ms is assumed in this test case.

This gives a total of 7.68 s, allow 8s in the test case.

The normative reference for this requirement is TS 25.133 [2] clauses 4.2.2.3 and A.4.2.2.

8.2.2.2.3 Test purpose

To verify that the UE meets the minimum requirement.

8.2.2.2.4 Method of test

8.2.2.2.4.1 Initial conditions

Test environment: normal; see clauses G.2.1 and G.2.2.

Frequencies to be tested: mid range; see clause G.2.4.

This scenario implies the presence of 2 carriers and 6 cells as given in tables 8.2.2.2.1 and 8.2.2.2.2. The UE is requested to monitor neighbouring cells on 2 carriers. The maximum repetition period of the relevant system info blocks that needs to be received by the UE to camp on a cell shall be 1 280 ms. Cell 1 and cell 2 shall belong to different Location Areas.

Table 8.2.2.2.1: Scenario 2: General test parameters for Cell Re-selection in multi carrier case

Parameter		Unit	Value	Comment
Initial condition	Active cell		Cell2	
	Neighbour cells		Cell1, Cell3, Cell4, Cell5, Cell6	
Final condition	Active cell		Cell1	
SYSTEM INFORMATION BLOCK TYPE 1 - CN common GSM-MAP NAS system information		-	00 80(H) → Cell 1 00 81(H) → Cell 2	This identity should be set as different value from the neighbour cell so that a Location Updating procedure (MM) or a Routing Area Updating procedure (GMM) is performed when UE selects more suitable cell in idle state.
Access Service Class (ASC#0) - Persistence value		-	1	Selected so that no additional delay is caused by the random access procedure. The value shall be used for all cells in the test.
HCS				Not used
DRX cycle length		S	1,28	The value shall be used for all cells in the test.
T1		s	30	T1 need to be defined so that cell re-selection reaction time is taken into account.
T2		s	15	T2 need to be defined so that cell re-selection reaction time is taken into account.

Table 8.2.2.2.2: Scenario 2: Test parameters for Cell re-selection multi carrier multi cell, initial conditions

Parameter	Unit	Cell 1		Cell 2		Cell 3		Cell 4		Cell 5		Cell 6	
		T1	T2	T1	T2	T1	T2	T1	T2	T1	T2	T1	T2
UTRA RF Channel Number		Channel 1		Channel 2		Channel 1		Channel 1		Channel 2		Channel 2	
CPICH_Ec/lor	dB	-10		-10		-10		-10		-10		-10	
PCCPCH_Ec/lor	dB	-12		-12		-12		-12		-12		-12	
SCH_Ec/lor	dB	-12		-12		-12		-12		-12		-12	
PICH_Ec/lor	dB	-15		-15		-15		-15		-15		-15	
OCNS_Ec/lor	dB	-0.941		-0.941		-0.941		-0.941		-0.941		-0.941	
\hat{I}_{or}/I_{oc}	dB	-3.4	2.2	2.2	-3.4	-7.4	-4.8	-7.4	-4.8	-4.8	-7.4	-4.8	-7.4
I_{oc}	dBm / 3.84 MHz	-70											
CPICH_Ec/lo	dB	-16	-13	-13	-16	-20		-20		-20		-20	
Propagation Condition		AWGN											
Cell_selection_and_reselection_quality_measure		CPICH E _c /N ₀		CPICH E _c /N ₀		CPICH E _c /N ₀		CPICH E _c /N ₀		CPICH E _c /N ₀		CPICH E _c /N ₀	
Qqualmin	dB	-20		-20		-20		-20		-20		-20	
Qrxlevmin	dBm	-115		-115		-115		-115		-115		-115	
UE_TXPWR_MAX_RACH	dB	21		21		21		21		21		21	
Qoffset _{2s, n}	dB	C1, C2: 0 C1, C3: 0 C1, C4: 0 C1, C5: 0 C1, C6: 0		C2, C1: 0 C2, C3: 0 C2, C4: 0 C2, C5: 0 C2, C6: 0		C3, C1: 0 C3, C2: 0 C3, C4: 0 C3, C5: 0 C3, C6: 0		C4, C1: 0 C4, C2: 0 C4, C3: 0 C4, C5: 0 C4, C6: 0		C5, C1: 0 C5, C2: 0 C5, C3: 0 C5, C4: 0 C5, C6: 0		C6, C1: 0 C6, C2: 0 C6, C3: 0 C6, C4: 0 C6, C5: 0	
Qhyst2	dB	0		0		0		0		0		0	
Treselection	s	0		0		0		0		0		0	
Sintrasearch	dB	not sent		not sent		not sent		not sent		not sent		not sent	
Sintersearch	dB	not sent		not sent		not sent		not sent		not sent		not sent	

8.2.2.2.4.2 Procedures

- 1) The SS activates cell 1-6 with T1 defined parameters in table 8.2.2.2.3 and monitors cell 1 and 2 for random access requests from the UE.
- 2) The UE is switched on.
- 3) The SS and the UE shall perform a first location registration procedure on cell2.
- 4) 30 s after step3 has completed, the parameters are changed to that as described for T2 in table 8.2.2.2.3.
- 5) The SS waits for random access request from the UE. If the UE responds on cell 1 within 8 s from the beginning of time period T2 then the number of successful tests is increased by one. The SS and the UE shall perform a Location Updating procedure (MM) or a Routing Area Updating procedure (GMM) on cell1.
- 6) After another 15 s from the beginning of time period T2, the parameters are changed to that as described for T1 in table 8.2.2.2.3.
- 7) The SS waits for random access requests from the UE. If the UE responds on cell 2 within 8 s from the beginning of time period T1 then the number of successful tests is increased by one. The SS and the UE shall perform a Location Updating procedure (MM) or a Routing Area Updating procedure (GMM) on cell2.
- 8) After 15 s from the beginning of time period T1, the parameters are changed as described for T2.
- 9) Repeat step 5) to 8) [TBD] times.

NOTE 1: T1 is initially 30 s to allow enough time for the UE to search for cells as it has no prior knowledge of these.

NOTE 2: The time required for receiving all the relevant system information data according to the reception procedure and the RRC procedure delay of system information blocks defined in 25.331 for a UTRAN cell. Since the maximum repetition period of the relevant system info blocks that needs to be received by the UE to camp on a cell is 1280ms and the maximum RRC procedure delay for reception system information block is 100ms, 1380 ms is assumed in this test case. Therefore this gives a total of 7.78s.(Minimum requirement + 100ms), allow 8s in the test case.

8.2.2.2.5 Test requirements

For the test to pass, the total number of successful tests shall be more than 90% with a confidence level of [FFS]% of the cases.

Table 8.2.2.3: Scenario 2: Test parameters for Cell re-selection multi carrier multi cell, test requirements

Parameter	Unit	Cell 1		Cell 2		Cell 3		Cell 4		Cell 5		Cell 6	
		T1	T2	T1	T2	T1	T2	T1	T2	T1	T2	T1	T2
UTRA RF Channel Number		Channel 1		Channel 2		Channel 1		Channel 1		Channel 2		Channel 2	
CPICH_Ec/Ior	dB	-9.9	-9.7	-9.7	-9.9	-9.9		-9.9		-9.9		-9.9	
PCCPCH_Ec/Ior	dB	-12		-12		-12		-12		-12		-12	
SCH_Ec/Ior	dB	-11.9	-11.7	-11.7	-11.9	-11.9		-11.9		-11.9		-11.9	
PICH_Ec/Ior	dB	-15		-15		-15		-15		-15		-15	
OCNS_Ec/Ior	dB	-0.954	-0.982	-0.982	-0.954	-0.954		-0.954		-0.954		-0.954	
\hat{I}_{or}/I_{oc}	dB	-3.5	2.8	2.8	-3.5	-9.5	-7.7	-9.5	-7.7	-7.7	-9.5	-7.7	-7.7
I_{oc}	dBm / 3.84 MHz	70											
CPICH_Ec/Io	dB	-15.6	-12	-12	-15.6	-21.6	-22.7	-21.6	-22.7	-22.7	-21.6	-22.7	-21.6
Propagation Condition		AWGN											
Cell_selection_and_reselection_quality_measure		CPICH E _c /N ₀		CPICH E _c /N ₀		CPICH E _c /N ₀		CPICH E _c /N ₀		CPICH E _c /N ₀		CPICH E _c /N ₀	
Qqualmin	dB	-20		-20		-20		-20		-20		-20	
Qrxlevmin	dBm	-115		-115		-115		-115		-115		-115	
UE_TXPWR_MAX_RACH	dB	21		21		21		21		21		21	
Qoffset2 _{s, n}	dB	C1, C2: 0 C1, C3: 0 C1, C4: 0 C1, C5: 0 C1, C6: 0	C2, C1: 0 C2, C3: 0 C2, C4: 0 C2, C5: 0 C2, C6: 0	C3, C1: 0 C3, C2: 0 C3, C4: 0 C3, C5: 0 C3, C6: 0	C4, C1: 0 C4, C2: 0 C4, C3: 0 C4, C5: 0 C4, C6: 0	C5, C1: 0 C5, C2: 0 C5, C3: 0 C5, C4: 0 C5, C6: 0	C6, C1: 0 C6, C2: 0 C6, C3: 0 C6, C4: 0 C6, C5: 0						
Qhyst2	dB	0		0		0		0		0		0	
Treselection	s	0		0		0		0		0		0	
Sintrasearch	dB	not sent		not sent		not sent		not sent		not sent		not sent	
Sintersearch	dB	not sent		not sent		not sent		not sent		not sent		not sent	

NOTE: If the above Test Requirement differs from the Minimum Requirement then the Test Tolerance applied for this test is non-zero. The Test Tolerance for this test is defined in clause F.2 and the explanation of how the Minimum Requirement has been relaxed by the Test Tolerance is given in clause F.4.

8.2.3 UTRAN to GSM Cell Re-Selection

8.2.3.1 Scenario 1: Both UTRA and GSM level changed

8.2.3.1.1 Definition and applicability

The cell re-selection delay is defined as the time from a change of cell levels to the moment when this change makes the UE camp on a new cell and starts to send the RR Channel Request message for location update to the new cell.

The requirements and this test apply to the combined FDD and GSM UE.

8.2.3.1.2 Minimum requirement

The cell re-selection delay shall be less than $26 \text{ s} + T_{\text{BCCH}}$, where T_{BCCH} is the maximum time allowed to read BCCH data from GSM cell TS 05.08 [20].

The rate of correct cell reselections observed during repeated tests shall be at least 90% with a confidence level of [FFS] %.

NOTE: The cell re-selection delay can be expressed as: $4 * T_{\text{measureGSM}} + T_{\text{BCCH}}$, where:

$T_{\text{measureGSM}}$ See table 4.1 in TS 25.133 [2] clause 4.2.2.

T_{BCCH} Maximum time allowed to read BCCH data from GSM cell TS 05.08 [20]. According to [20], the maximum time allowed to read the BCCH data, when being synchronized to a BCCH carrier, is 1.9 s.

This gives a total of $25.6 \text{ s} + T_{\text{BCCH}}$, allow $26 \text{ s} + T_{\text{BCCH}}$ in the test case.

The normative reference for this requirement is TS 25.133 [2] clauses 4.2.2 and A.4.3.1.

8.2.3.1.3 Test purpose

To verify that the UE meets the minimum requirement.

8.2.3.1.4 Method of test

8.2.3.1.4.1 Initial conditions

Test environment: normal; see clauses G.2.1 and G.2.2.

Frequencies to be tested: mid range; see clause G.2.4.

This scenario implies the presence of 1 UTRAN serving cell, and 1 GSM cell to be re-selected. The UE is requested to monitor neighbouring cells on 1 UMTS carrier and 12 GSM cells. Cell 1 and cell 2 shall belong to different Location Areas.

Table 8.2.3.1.1: Scenario 1: General test parameters for UTRAN to GSM Cell Re-selection

Parameter		Unit	Value	Comment
Initial condition	Active cell		Cell1	
	Neighbour cell		Cell2	
Final condition	Active cell		Cell2	
HCS				Not used
DRX cycle length		s	1.28	
T1		s	45	
T2		s	35	

Table 8.2.3.1.2: Scenario 1: Cell re-selection UTRAN to GSM cell case (cell 1), initial conditions

Parameter	Unit	Cell 1 (UTRA)	
		T1	T2
UTRA RF Channel Number		Channel 1	
CPICH_Ec/Ior	dB	-10	
PCCPCH_Ec/Ior	dB	-12	
SCH_Ec/Ior	dB	-12	
PICH_Ec/Ior	dB	-15	
OCNS_Ec/Ior	dB	-0.941	
\hat{I}_{or}/I_{oc}	dB	0	-5
I_{oc}	dBm/3.84 MHz	-70	
CPICH_Ec/Io	dB	-13	-16.2
CPICH_RSCP	dBm	-80	-85
Propagation Condition		AWGN	
Cell_selection_and_reselection_quality_measure		CPICH E_c/N_0	
Qqualmin	dB	-20	
Qrxlevmin	dBm	-115	
UE_TXPWR_MAX_RACH	dBm	21	
Qoffset1s,n	dB	C1, C2: 0	
Qhyst1	dB	0	
Treselection	s	0	
SsearchRAT	dB	not sent	

Table 8.2.3.1.3: Scenario 1: Cell re-selection UTRAN to GSM cell case (cell 2), initial conditions

Parameter	Unit	Cell 2 (GSM)	
		T1	T2
Absolute RF Channel Number		ARFCN 1	
RXLEV	dBm	-90	-75
RXLEV_ACCESS_MIN	dBm	-104	
MS_TXPWR_MAX_CCH	dBm	33	

8.2.3.1.4.2 Procedure

- 1) The SS activates cell 1 and 2 with T1 defined parameters in tables 8.2.3.1.4 and 8.2.3.1.5 and monitors cell 1 and 2 for random access requests from the UE.
- 2) The UE is switched on.
- 3) The SS waits for random access requests from the UE on cell 1.
- 4) After 45 s, the parameters are changed as described for T2 in tables 8.2.3.1.4 and 8.2.3.1.5.
- 5) The SS waits for random access requests from the UE. If the UE responds on cell 2 within 28 s then the number of successful tests is increased by one.
- 6) After 35 s, the parameters are changed as described for T1 in tables 8.2.3.1.4 and 8.2.3.1.5.
- 7) The SS waits for random access requests from the UE on cell 1.
- 8) Repeat step 4) to 7) [TBD] times.

8.2.3.1.5 Test requirements

Table 8.2.3.1.4: Scenario 1: Cell re-selection UTRAN to GSM cell case (cell 1), test requirements

Parameter	Unit	Cell 1 (UTRA)	
		T1	T2
UTRA RF Channel Number		Channel 1	
CPICH_Ec/I _{or}	dB	-9.9	-10.1
PCCPCH_Ec/I _{or}	dB	-12	
SCH_Ec/I _{or}	dB	-12	
PICH_Ec/I _{or}	dB	-15	
OCNS_Ec/I _{or}	dB	-0.953	-0.928
\hat{I}_{or}/I_{oc}	dB	0.3	-5.3
I_{oc} (Note 1)	dBm/3.84 MHz	-70	
CPICH_Ec/I _o (Note 2)	dB	-12.8	-16.5
CPICH_RSCP (Note2)	dBm	-79.6	-85.4
Propagation Condition		AWGN	
Cell_selection_and_reselection_quality_measure		CPICH E _c /N ₀	
Qqualmin	dB	-20	
Qrxlevmin	dBm	-115	
UE_TXPWR_MAX_RACH	dBm	21	
Qoffset1 _{s,n}	dB	C1, C2: 0	
Qhyst1	dB	0	
Treselection	s	0	
Ssearch _{RAT}	dB	not sent	

Table 8.2.3.1.5: Scenario 1: Cell re-selection UTRAN to GSM cell case (cell 2), test requirements

Parameter	Unit	Cell 2 (GSM)	
		T1	T2
Absolute RF Channel Number		ARFCN 1	
RXLEV (Note 1)	dBm	-90	-75
RXLEV_ACCESS_MIN	dBm	-104	
MS_TXPWR_MAX_CCH	dBm	33	

NOTE 1: For T1 the the ratio $(I_{oc}/R_{xlev})_{\text{test requirement}} = (I_{oc}/R_{xlev})_{\text{minimum requirement}} + 0.3 \text{ dB}$

For T2 the the ratio $(I_{oc}/R_{xlev})_{\text{test requirement}} = (I_{oc}/R_{xlev})_{\text{minimum requirement}} - 0.3 \text{ dB}$

NOTE 2: CPICH_Ec/Io and CPICH_RSCP levels have been calculated from other parameters for information purposes. They are not settable parameters themselves.

For the test to pass, the total number of successful tests shall be at least 90% of the cases with a confidence level of [FFS]%.

NOTE: If the above Test Requirement differs from the Minimum Requirement then the Test Tolerance applied for this test is non-zero. The Test Tolerance for this test is defined in clause F.2 and the explanation of how the Minimum Requirement has been relaxed by the Test Tolerance is given in clause F.4.

8.2.3.2 Scenario 2: Only UTRA level changed

8.2.3.2.1 Definition and applicability

The cell re-selection delay is defined as the time from a change of cell levels to the moment when this change makes the UE camp on a new cell and starts to send the RR Channel Request message for location update to the new cell.

The requirements and this test apply to the combined FDD and GSM UE.

8.2.3.2.2 Minimum requirement

The cell re-selection delay shall be less than $7.7 \text{ s} + T_{\text{BCCH}}$, where T_{BCCH} is the maximum time allowed to read BCCH data from GSM cell TS 05.08 [20].

The rate of correct cell reselections observed during repeated tests shall be at least 90% with a confidence level of [FFS]%.

NOTE: The cell re-selection delay can be expressed as: $\text{Max}(3 * T_{\text{measureFDD}}, T_{\text{measureGSM}} + \text{DRX cycle length}) + T_{\text{BCCH}}$, where:

$T_{\text{measureFDD}}$ See table 4.1 in TS 25.133 [2] clause 4.2.2.

$T_{\text{measureGSM}}$ See table 4.1 in TS 25.133 [2] clause 4.2.2.

DRX cycle length 1.28s see Table A.4.7.A in TS 25.133 [2] clause A.4.3.2.

T_{BCCH} Maximum time allowed to read BCCH data from GSM cell TS 05.08 [20]. According to [20], the maximum time allowed to read the BCCH data, when being synchronized to a BCCH carrier, is 1.9 s.

This gives a total of $7.68 \text{ s} + T_{\text{BCCH}}$, allow $7.7 \text{ s} + T_{\text{BCCH}}$ in the test case.

The normative reference for this requirement is TS 25.133 [2] clauses 4.2.2 and A.4.3.2.

8.2.3.2.3 Test purpose

To verify that the UE meets the minimum requirement.

8.2.3.2.4 Method of test

8.2.3.2.4.1 Initial conditions

Test environment: normal; see clauses G.2.1 and G.2.2.

Frequencies to be tested: mid range; see clause G.2.4.

This scenario implies the presence of 1 UTRAN serving cell, and 1 GSM cell to be re-selected. The UE is requested to monitor neighbouring cells on 1 UMTS carrier and 12 GSM cells. Cell 1 and cell 2 shall belong to different Location Areas.

Table 8.2.3.2.1: Scenario 2: General test parameters for UTRAN to GSM Cell Re-selection

Parameter		Unit	Value	Comment
Initial condition	Active cell		Cell1	
	Neighbour cell		Cell2	
Final condition	Active cell		Cell2	
HCS				Not used
DRX cycle length		s	1.28	
T1		s	45	
T2		s	12	

Table 8.2.3.2.2: Scenario 2: Cell re-selection UTRAN to GSM cell case (cell 1), initial conditions

Parameter	Unit	Cell 1 (UTRA)	
		T1	T2
UTRA RF Channel Number		Channel 1	
CPICH_Ec/I _{or}	dB	-10	
PCCPCH_Ec/I _{or}	dB	-12	
SCH_Ec/I _{or}	dB	-12	
PICH_Ec/I _{or}	dB	-15	
OCNS_Ec/I _{or}	dB	-0.941	
\hat{I}_{or}/I_{oc}	dB	20	-9
I_{oc}	dBm/3.84 MHz	-81	
CPICH_Ec/I _o	dB	-10.0	-19.5
CPICH_RSCP	dBm	-70	-100
Propagation Condition		AWGN	
Cell_selection_and_reselection_quality_measure		CPICH E _c /N ₀	
Qqualmin	dB	-20	
Qrxlevmin	dBm	-115	
UE_TXPWR_MAX_RACH	dBm	21	
Qoffset1 _{s,n}	dB	C1, C2: 0	
Qhyst1	dB	0	
Treselection	s	0	
Ssearch _{RAT}	dB	not sent	

Table 8.2.3.2.3: Scenario 2: Cell re-selection UTRAN to GSM cell case (cell 2), initial conditions

Parameter	Unit	Cell 2 (GSM)	
		T1	T2
Absolute RF Channel Number		ARFCN 1	
RXLEV	dBm	-80	-80
RXLEV_ACCESS_MIN	dBm	-104	
MS_TXPWR_MAX_CCH	dBm	33	

8.2.3.2.4.2 Procedure

- 1) The SS activates cell 1 and 2 with T1 defined parameters in tables 8.2.3.2.4 and 8.2.3.2.5 and monitors cell 1 and 2 for random access requests from the UE.
- 2) The UE is switched on.
- 3) The SS waits for random access requests from the UE on cell 1.
- 4) After 45 s, the parameters are changed as described for T2 in tables 8.2.3.2.4 and 8.2.3.2.5.
- 5) The SS waits for random access requests from the UE. If the UE responds on cell 2 within 9.7 s then the number of successful tests is increased by one.
- 6) After 12 s, the parameters are changed as described for T1 in tables 8.2.3.2.4 and 8.2.3.2.5.
- 7) The SS waits for random access requests from the UE on cell 1.
- 8) Repeat step 4) to 7) [TBD] times.

8.2.3.2.5 Test requirements

Table 8.2.3.2.4: Scenario 2: Cell re-selection UTRAN to GSM cell case (cell 1), test requirements

Parameter	Unit	Cell 1 (UTRA)	
		T1	T2
UTRA RF Channel Number		Channel 1	
CPICH_Ec/I _{or}	dB	-9.9	-10.1
PCCPCH_Ec/I _{or}	dB	-12	
SCH_Ec/I _{or}	dB	-12	
PICH_Ec/I _{or}	dB	-15	
OCNS_Ec/I _{or}	dB	-0.953	-0.941
\hat{I}_{or}/I_{oc}	dB	20.3	-9.3
I_{oc} (Note1)	dBm/3.84 MHz	-81	
CPICH_Ec/I _o (Note2)	dB	-9.9	-19.9
CPICH_RSCP (Note2)	dBm	-70.6	-100.4
Propagation Condition		AWGN	
Cell_selection_and_reselection_quality_measure		CPICH E _c /N ₀	
Qqualmin	dB	-20	
Qrxlevmin	dBm	-115	
UE_TXPWR_MAX_RACH	dBm	21	
Qoffset1 _{s,n}	dB	C1, C2: 0	
Qhyst1	dB	0	
Treselection	s	0	
Ssearch _{RAT}	dB	not sent	

Table 8.2.3.2.5: Scenario 2: Cell re-selection UTRAN to GSM cell case (cell 2), test requirements

Parameter	Unit	Cell 2 (GSM)	
		T1	T2
Absolute RF Channel Number		ARFCN 1	
RXLEV (Note1)	dBm	-80	-80
RXLEV_ACCESS_MIN	dBm	-104	
MS_TXPWR_MAX_CCH	dBm	33	

NOTE 1: For T1 the the ratio $(I_{oc}/R_{xlev})_{\text{test requirement}} = (I_{oc}/R_{xlev})_{\text{minimum requirement}} + 0.3 \text{ dB}$

For T2 the the ratio $(I_{oc}/R_{xlev})_{\text{test requirement}} = (I_{oc}/R_{xlev})_{\text{minimum requirement}} - 0.3 \text{ dB}$

NOTE 2: CPICH_Ec/I_o and CPICH_RSCP levels have been calculated from other parameters for information purposes. They are not settable parameters themselves.

For the test to pass, the total number of successful tests shall be at least 90% of the cases with a confidence level of [FFS]%.

NOTE: If the above Test Requirement differs from the Minimum Requirement then the Test Tolerance applied for this test is non-zero. The Test Tolerance for this test is defined in clause F.2 and the explanation of how the Minimum Requirement has been relaxed by the Test Tolerance is given in clause F.4.

8.2.4 FDD/TDD Cell Re-selection

8.2.4.1 Definition and applicability

The cell re-selection delay is defined as the time from the cell quality levels change to the moment when this change makes the UE reselect a better ranked cell, and starts to send the RRC CONNECTION REQUEST message to perform a Location Registration on the new cell.

This test is for the case where the UE camps on an FDD cell and reselects to a TDD cell.

The requirements and this test apply to UEs supporting both FDD and TDD.

8.2.4.2 Minimum requirement

The cell re-selection delay shall be less than 8 s with a DRX cycle length of 1,28 s. This shall be verified in more than [FFS]% of the cases with a confidence level of [FFS]%.

The normative reference for this requirement is TS 25.133 [2] clauses 4.2.2.4 and A.4.4.

8.2.4.3 Test purpose

To verify that the UE meets the minimum requirement for the case where the UE camps on an FDD cell and reselects to a TDD cell.

8.2.4.4 Method of test

8.2.4.4.1 Initial conditions

This scenario implies the presence of UTRA FDD and 1 UTRA TDD cell as given in tables 8.2.4.1, 8.2.4.2 and 8.2.4.3. The maximum repetition period of the relevant system information blocks that need to be received by the UE to camp on a cell shall be 1280 ms.

Cell 1 and cell 2 shall belong to different Location Areas.

Table 8.2.4.1: General test parameters for FDD/TDD Cell Re-selection

Parameter		Unit	Value	Comment
Initial condition	Active cell		Cell1	FDD cell
	Neighbour cells		Cell2	TDD cell
Final condition	Active cell		Cell2	TDD cell
UE_TXPWR_MAX_RACH		dBm	21	The value shall be used for all cells in the test.
Access Service Class (ASC#0) - Persistence value			1	Selected so that no additional delay is caused by the random access procedure. The value shall be used for all cells in the test.
HCS				Not used
DRX cycle length		S	1.28	The value shall be used for all cells in the test.
T1		S	15	
T2		S	15	

Table 8.2.4.2: Cell 1 specific test parameters for FDD/TDD Cell Re-selection

Parameter	Unit	Cell 1	
		T1	T2
UTRA RF Channel Number		Channel 1	
CPICH_Ec/lor	dB	-10	
P-CCPCH_Ec/lor	dB	-12	
SCH_Ec/lor	dB	-12	
PICH_Ec/lor	dB	-15	
OCNS_Ec/lor	dB	-0.941	
\hat{I}_{or}/I_{oc}	dB	9	3
I_{oc}	dBm / 3.84 MHz	-70	
CPICH_RSCP	dBm	-71	-77
Propagation Condition		AWGN	
Cell_selection_and_reselection_quality_measure		CPICH_Ec/No	
Qrxlevmin	dBm	-115	
Qoffset1 _{s,n}	dB	0	
Qhyst1	dB	0	
Treselection	s	0	
Sintrasearch	dB	not sent	
Sintersearch	dB	not sent	

Table 8.2.4.3: Cell 2 specific test parameters for FDD/TDD Cell Re-selection

Parameter	Unit	Cell 2			
		0		8	
DL timeslot number		T1	T2	T1	T2
UTRA RF Channel Number		Channel 2			
P-CCPCH_Ec/lor	dB	-3		n.a.	
PICH_Ec/lor	dB	n.a.		-3	
SCH_Ec/lor	dB	-9			
SCH_t_offset	dB	10			
OCNS_Ec/lor	dB	-3.12			
\hat{I}_{or}/I_{oc}	dB	-4	2	-4	2
P-CCPCH RSCP	dBm	-77	-71	n.a.	n.a.
I_{oc}	dBm/ 3,84 MHz	-70			
Propagation Condition		AWGN			
Qrxlevmin	dBm	-103			
Qoffset2 _{s,n}	dB	0			
Qhyst2	dB	0			
Treselection	s	0			
Sintrasearch	dB	not sent			
Sintersearch	dB	not sent			
Note that the transmit energy per PN chip for the SCH is averaged over the 256 chip duration when the SCH is present in the time slot.					

8.2.4.4.2 Procedures

- The SS activates cell 1 and cell 2 with T1 defined parameters and monitors them for random access requests from the UE.
- The UE is switched on.
- The SS waits for random access requests from the UE.
- After 15 s, the parameters are changed as described for T2.
- The SS waits for random access request from the UE.
- After another 15 s, the parameters are changed as described for T1.
- The SS waits for random access requests from the UE.
- Repeat step d) to g) [TBD] times.

8.2.4.5 Test requirements

- In step c), after the UE has responded on cell 1, it shall not respond on any other cell (cell selection).
- In step e), the UE shall respond on cell 2 within 8 s in more than [FFS]% of the cases.
- In step g), the UE shall respond on cell 1.

NOTE: If the above Test Requirement differs from the Minimum Requirement then the Test Tolerance applied for this test is non-zero. The Test Tolerance for this test is defined in clause F.2 and the explanation of how the Minimum Requirement has been relaxed by the Test Tolerance is given in clause F.4.

8.3 UTRAN Connected Mode Mobility

8.3.1 FDD/FDD Soft Handover

8.3.1.1 Definition and applicability

The active set update delay of the UE is defined as the time from the end of the last TTI containing an RRC message implying soft handover to the switch off of the old downlink DPCH.

The requirements and this test apply to the FDD UE.

8.3.1.2 Minimum requirement

The active set update delay shall be less than 60 ms in CELL_DCH state. The rate of correct soft handovers observed during repeated tests shall be at least 90% with a confidence level of [FFS]%.

The active set update delay is defined as the time from when the UE has received the ACTIVE SET UPDATE message from UTRAN, or at the time stated through the activation time when to perform the active set update, to the time when the UE successfully uses the set of radio links stated in that message for power control.

The active set update delay is depending on the number of known cells referred to in the ACTIVE SET UPDATE message. A cell is known if either or both of the following conditions are true:

- the UE has had radio links connected to the cell in the previous (old) active set.
- the cell has been measured by the UE during the last 5 seconds and the SFN of the cell has been decoded by the UE.

And the phase reference is the primary CPICH.

The active set update delay shall be less than $50+10*KC+100*OC$ ms, where

KC is the number of known cells in the active set update message.

OC is the number of cells that are not known in the active set update message.

The normative reference for this requirement is TS 25.133 [2] clauses 5.1.2 and A.5.1.1.

8.3.1.3 Test purpose

To verify that the UE meets the minimum requirement.

8.3.1.4 Method of test

8.3.1.4.1 Initial conditions

Test environment: normal; see clauses G.2.1 and G.2.2.

Frequencies to be tested: mid range; see clause G.2.4.

The test parameters are given in table 8.3.1.1.1 and 8.3.1.1.2 below. In the measurement control information it is indicated to the UE that event-triggered reporting with Event 1A shall be used, and that CPICH Ec/Io and SFN-CFN observed time difference shall be reported together with Event 1A. The test consists of five successive time periods, with a time duration of T1, T2, T3, T4 and T5 respectively. At the start of time duration T1, the UE may not have any timing information of cell 2.

UTRAN shall send an Active Set Update command with activation time "now", adding cell 2 to the active set. The Active Set Update message shall be sent to the UE so that the whole message is available at the UE at the beginning of T4. The RRC procedure delay is defined in TS 25.133 [2].

Table 8.3.1.1.1: General test parameters for Soft handover

Parameter		Unit	Value	Comment
DCH parameters			DL and UL Reference Measurement Channel 12.2 kbps	As specified in clause C.3.1 and C.2.1
Power Control			On	
Target quality value on DTCH		BLER	0.01	
Initial conditions	Active cell		Cell 1	
	Neighbouring cell		Cell 2	
Final condition	Active cell		Cell 2	
Reporting range		dB	3	Applicable for event 1A and 1B
Hysteresis		dB	0	
W			1	Applicable for event 1A and 1B
Reporting deactivation threshold			0	Applicable for event 1A
Time to Trigger		ms	0	
Filter coefficient			0	
T1		s	5	
T2		s	3	
T3		s	0.5	
T4		ms	60	This is the requirement on active set update delay, see clause 5.1.2.2, where KC=1 and OC=0.
T5		s	2	

Table 8.3.1.1.2: Cell specific test parameters for Soft handover

Parameter	Unit	Cell 1					Cell 2				
		T1	T2	T3	T4	T5	T1	T2	T3	T4	T5
CPICH_Ec/I _{or}	dB	-10					-10				
PCCPCH_Ec/I _{or}	dB	-12					-12				
SCH_Ec/I _{or}	dB	-12					-12				
PICH_Ec/I _{or}	dB	-15					-15				
DPCH_Ec/I _{or}	dB	Note1	Note1	Note1	N/A	N/A	N/A	Note3	Note1		
OCNS		Note2	Note2	Note2	-0.941	-0.941	-0.941	Note2	Note2		
\hat{I}_{or}/I_{oc}	dB	0	2.91	2.91	2.91	-Inf	2.91	2.91	2.91		
I_{oc}	dBm/ 3.84 MHz	-70									
CPICH_Ec/I _o	dB	-13	-14	-14	-14	-Inf	-14	-14	-14		
Propagation Condition		AWGN									
Note 1: The DPCH level is controlled by the power control loop											
Note 2: The power of the OCNS channel that is added shall make the total power from the cell to be equal to I_{or}											
Note 3: The DPCH level is controlled by the power control loop. The initial power shall be set equal to the DPCH_Ec/I _{or} of Cell 1 at the end of T2.											

8.3.1.4.2 Procedure

- 1) The RF parameters are set up according to T1.
- 2) The UE is switched on.
- 3) A call is set up according to the test procedure specified in TS 34.108 [3] subclause 7.3.4 without Compressed mode parameters.

[Editor's note: subclause 7.3.4 in TS 34.108 (Message sequence chart for Handover Test procedure) is not yet specified]

- 4) SS shall transmit a MEASUREMENT CONTROL message.
- 5) 5 seconds after step4 has completed, the SS shall switch the power settings from T1 to T2.
- 6) UE shall transmit a MEASUREMENT REPORT message triggered by event 1A containing the CFN-SFN observed time difference between cell 1 and cell 2.
- 7) At the beginning of T3 the downlink DPCH of cell 2 shall be activated.
- 8) SS shall send an ACTIVE SET UPDATE message with activation time "now ", adding cell 2 to the active set. The ACTIVE SET UPDATE message shall be sent to the UE so that the whole message is available at the UE at the beginning of T4.
- 9) At the beginning of T5 the DPCH from cell 1 shall be switched off.
- 10) The UE downlink BLER shall be measured during time period T5. If the UE downlink BLER does not exceed the downlink BLER target, i.e. 1%, during time period T5 then the number of successful tests is increased by one.
- 11) 5 seconds after step10 has completed, the UE is switched off. Any timing information of cell 2 is deleted in the UE.
- 12) Repeat step 1-11[TBD] times

Specific Message Contents

All messages indicated above shall use the same content as described in the default message content in clause 9 of 34.108 [3], with the following exceptions:

MEASUREMENT CONTROL message (step 4):

Information Element/Group name	Value/Remark
Message Type (10.2.17)	
UE information elements -RRC transaction identifier -Integrity check info	0 Not Present
Measurement Information elements -Measurement Identity -Measurement Command (10.3.7.46) -Measurement Reporting Mode (10.3.7.49) -Measurement Report Transfer Mode -Periodical Reporting / Event Trigger Reporting Mode -Additional measurements list (10.3.7.1)	1 Modify AM RLC Event trigger Not Present
-CHOICE <i>Measurement type</i> -Intra-frequency measurement (10.3.7.36) -Intra-frequency measurement objects list (10.3.7.33) -Intra-frequency measurement quantity (10.3.7.38) -Filter coefficient (10.3.7.9) -CHOICE mode -Measurement quantity -Intra-frequency reporting quantity (10.3.7.41)	Intra-frequency measurement Not Present 0 FDD CPICH_Ec/N0
-Reporting quantities for active set cells (10.3.7.5) -SFN-SFN observed time difference reporting indicator -Cell synchronisation information reporting indicator -Cell Identity reporting indicator -CHOICE mode -CPICH Ec/N0 reporting indicator -CPICH RSCP reporting indicator -Pathloss reporting indicator	No report TRUE (Note 1) TRUE FDD TRUE TRUE TRUE
-Reporting quantities for monitored set cells (10.3.7.5) -SFN-SFN observed time difference reporting indicator -Cell synchronisation information reporting indicator -Cell Identity reporting indicator -CHOICE mode -CPICH Ec/N0 reporting indicator -CPICH RSCP reporting indicator -Pathloss reporting indicator	No report TRUE (Note 1) TRUE FDD TRUE TRUE TRUE
-Reporting quantities for detected set cells (10.3.7.5)	Not Present
-Reporting cell status (10.3.7.61) -Measurement validity (10.3.7.51) -CHOICE report criteria -Intra-frequency measurement reporting criteria (10.3.7.39) -Parameters required for each event	Not Present Not Present Intra-frequency measurement reporting criteria 2
-Intra-frequency event identity -Triggering condition 2 -Reporting Range Constant -Cells forbidden to affect Reporting Range -W -Hysteresis -Threshold used frequency -Reporting deactivation threshold -Replacement activation threshold -Time to trigger -Amount of reporting -Reporting interval -Reporting cell status	Event 1A Active set cells and monitored set cells 3 dB Not Present 1.0 0 dB Not Present 0 Not Present 0 ms Infinity 0 ms (Note 2) Not Present
-Intra-frequency event identity -Triggering condition 1 -Reporting Range Constant -Cells forbidden to affect Reporting Range -W -Hysteresis -Threshold used frequency -Reporting deactivation threshold -Replacement activation threshold -Time to trigger	Event 1B Active set cells and monitored set cells 3 dB Not Present 1.0 0 dB Not Present Not Present Not Present 0 ms

Information Element/Group name	Value/Remark
-Amount of reporting -Reporting interval -Reporting cell status	Not Present Not Present Not Present
Physical channel information elements -DPCH compressed mode status info (10.3.6.34)	Not Present
Note 1: The SFN-CFN observed time difference is calculated from the OFF and Tm parameters contained in the IE "Cell synchronisation information", TS 25.331, clause 10.3.7.6. According to TS 25.331, 8.6.7.7, this IE is included in MEASUREMENT REPORT if IE "Cell synchronisation information reporting indicator" in IE "Cell reporting quantities" TS 25.331, clause 10.3.7.5 is set to TRUE in MEASUREMENT CONTROL.	
Note 2: Reporting interval = 0 ms means no periodical reporting	

ACTIVE SET UPDATE message (step 8):

Information Element/Group name	Type and reference	Value/Remark
Message Type	Message Type	
UE information elements		
RRC transaction identifier	RRC transaction identifier 10.3.3.36	0
Integrity check info	Integrity check info 10.3.3.16	Not Present
Integrity protection mode info	Integrity protection mode info 10.3.3.19	Not Present
Ciphering mode info	Ciphering mode info 10.3.3.5	Not Present
Activation time	Activation time 10.3.3.1	"now".
New U-RNTI	U-RNTI 10.3.3.47	Not Present
CN information elements		
CN Information info	CN Information info 10.3.1.3	Not Present
Phy CH information elements		
Uplink radio resources		
Maximum allowed UL TX power	Maximum allowed UL TX power 10.3.6.39	33 dBm
Downlink radio resources		
Radio link addition information		Radio link addition information required for each RL to add
>Radio link addition information	Radio link addition information 10.3.6.68	
Radio link removal information		Radio link removal information required for each RL to remove
>Radio link removal information	Radio link removal information 10.3.6.69	Not Present
TX Diversity Mode	TX Diversity Mode 10.3.6.86	None
SSDT information	SSDT information 10.3.6.77	Not Present

Radio link addition information

Information Element/Group name	Need	Multi	Type and reference	Value/Remark
Primary CPICH info	MP		Primary CPICH info 10.3.6.60	Same as defined in cell2
Downlink DPCH info for each RL	MP		Downlink DPCH info for each RL 10.3.6.21	See below
TFCI combining indicator	MP		TFCI combining indicator 10.3.6.81	FALSE
SCCPCH Information for FACH	OP		SCCPCH Information for FACH 10.3.6.70	Not Present

Downlink DPCH info for each RL

Information Element/Group name	Type and reference	Value/Remark
CHOICE <i>mode</i>		
>FDD		
>>Primary CPICH usage for channel estimation	Primary CPICH usage for channel estimation 10.3.6.62	Primary CPICH may be used
>>DPCH frame offset	Integer(0..38144 by step of 256)	This should be reflected by the IE " Cell synchronisation information" in received MEASUREMENT REPORT message
>>Secondary CPICH info	Secondary CPICH info 10.3.6.73	Not Present
>>DL channelisation code		
>>>Secondary scrambling code	Secondary scrambling code 10.3.6.74	Not Present
>>>Spreading factor	Integer(4, 8, 16, 32, 64, 128, 256, 512)	128
>>>Code number	Integer(0..Spreading factor - 1)	0
>>>Scrambling code change	Enumerated (code change, no code change)	No code change
>>TPC combination index	TPC combination index 10.3.6.85	0
>>SSDT Cell Identity	SSDT Cell Identity 10.3.6.76	Not Present
>>Closed loop timing adjustment mode	Integer(1, 2)	Not Present

NOTE 1: These IEs are present when the UE needs to listen to system information on FACH in CELL_DCH state.

8.3.1.5 Test requirements

For the test to pass, the total number of successful tests shall be more than 90% with a confidence level of [FFS]% of the cases.

NOTE: If the above Test Requirement differs from the Minimum Requirement then the Test Tolerance applied for this test is non-zero. The Test Tolerance for this test is defined in clause F.2 and the explanation of how the Minimum Requirement has been relaxed by the Test Tolerance is given in clause F.4.

8.3.2 FDD/FDD Hard Handover

8.3.2.1 FDD/FDD Hard Handover to intra-frequency cell

8.3.2.1.1 Definition and applicability

The hard handover delay of the UE is defined as the time from the end of the last TTI containing an RRC message implying hard handover to the transmission of the new uplink DPCH.

The requirements and this test apply to the FDD UE.

8.3.2.1.2 Minimum requirement

The interruption time shall be less than 110 ms in CELL_DCH state in the single carrier case. The rate of correct handovers observed during repeated tests shall be at least 90% with a confidence level of [FFS]%.

The hard handover delay D_{handover} equals the RRC procedure delay defined in TS 25.331 clause 13.5.2 plus the interruption time stated in TS 25.133 clause 5.2.2.2 as follows:

The interruption time, i.e. the time between the last TTI containing a transport block on the old DPDCH and the time the UE starts transmission of the new uplink DPCCH, is depending on whether the target cell is known for the UE or not.

If intra-frequency hard handover is commanded or inter-frequency hard handover is commanded when the UE does not need compressed mode to perform inter-frequency measurements, the interruption time shall be less than $T_{\text{interrupt1}}$

$$T_{\text{interrupt1}} = T_{\text{IU}} + 40 + 20 * \text{KC} + 150 * \text{OC} + 10 * F_{\text{max}} \text{ ms}$$

where

T_{IU} is the interruption uncertainty when changing the timing from the old to the new cell. T_{IU} can be up to one frame (10 ms).

KC is the number of known target cells in the message, and

OC is the number of target cells that are not known in the message.

F_{max} denotes the maximum number of radio frames within the transmission time intervals of all transport channels that are multiplexed into the same CCTrCH.

Note: The figure 40 ms is the time required for measuring the downlink DPCCH channel as stated in TS 25.214 clause 4.3.1.2.

In the interruption requirement $T_{\text{interrupt1}}$ a cell is known if either or both of the following conditions are true:

- the UE has had radio links connected to the cell in the previous (old) active set
- the cell has been measured by the UE during the last 5 seconds and the SFN of the cell has been decoded by the UE.

The normative reference for this requirement is TS 25.133 [2] clauses 5.2.2 and A.5.2.1.

8.3.2.1.3 Test purpose

To verify that the UE meets the minimum requirement.

8.3.2.1.4 Method of test

8.3.2.1.4.1 Initial conditions

Test environment: normal; see clauses G.2.1 and G.2.2.

Frequencies to be tested: mid range; see clause G.2.4.

The test parameters are given in table 8.3.2.1.1 and 8.3.2.1.2 below. In the measurement control information it is indicated to the UE that event-triggered reporting with Event 1A and 1B shall be used, and that CPICH Ec/Io and SFN-CFN observed timed difference shall be reported together with Event 1A. The test consists of three successive time periods, with a time duration of T1, T2 and T3 respectively. At the start of time duration T1, the UE may not have any timing information of cell 2.

UTRAN shall send a PHYSICAL CHANNEL RECONFIGURATION with activation time at beginning of T3 with one active cell, cell 2. The Physical Channel reconfiguration message shall be sent to the UE so that the whole message is available at the UE the RRC procedure delay prior to the beginning of T3. The RRC procedure delay is defined in TS 25.331 [8].

N312 shall have the smallest possible value i.e. only one insync is required.

Table 8.3.2.1.1: General test parameters for Handover to intra-frequency cell

Parameter		Unit	Value	Comment
DCH parameters			DL and UL Reference Measurement Channel 12.2 kbps	As specified in clause C.3.1 and C.2.1
Power Control			On	
Target quality value on DTCH		BLER	0.01	
Initial conditions	Active cell		Cell 1	
	Neighbouring cell		Cell 2	
Final condition	Active cell		Cell 2	
Reporting range		dB	3	Applicable for event 1A and 1B
Hysteresis		dB	0	
W			1	Applicable for event 1A and 1B
Reporting deactivation threshold			0	Applicable for event 1A
Time to Trigger		ms	0	
Filter coefficient			0	
T1		s	5	
T2		s	5	
T3		s	5	

Table 8.3.2.1.2: Cell specific test parameters for Handover to intra-frequency cell

Parameter	Unit	Cell 1			Cell 2		
		T1	T2	T3	T1	T2	T3
CPICH_Ec/I _{or}	dB	-10			-10		
PCCPCH_Ec/I _{or}	dB	-12			-12		
SCH_Ec/I _{or}	dB	-12			-12		
PICH_Ec/I _{or}	dB	-15			-15		
DPCH_Ec/I _{or}	dB	Note1	Note1	Note3	N/A	N/A	Note1
OCNS		Note2	Note2	Note2	-0.941	-0.941	Note2
\hat{I}_{or}/I_{oc}	dB	0	6.97		-Infinity	5.97	
I_{oc}	dBm/ 3.84 MHz	-70					
CPICH_Ec/I _o	dB	-13			-Infinity	-14	
Propagation Condition		AWGN					
Note 1: The DPCH level is controlled by the power control loop							
Note 2: The power of the OCNS channel that is added shall make the total power from the cell to be equal to I_{or} .							
Note 3: The DPCH may not be power controlled by the power control loop.							

8.3.2.1.4.2 Procedure

- 1) The RF parameters are set up according to T1.
- 2) The UE is switched on.
- 3) A call is set up according to the test procedure specified in TS 34.108 [3] subclause 7.3.4.

[Editor's note: subclause 7.3.4 in TS 34.108 (Message sequence chart for Handover Test procedure) is not yet specified]

- 4) SS shall transmit a MEASUREMENT CONTROL message.
- 5) 5 seconds after step4 has completed, the SS shall switch the power settings from T1 to T2
- 6) UE shall transmit a MEASUREMENT REPORT message triggered by event 1A

- 7) SS shall transmit a PHYSICAL CHANNEL RECONFIGURATION message with activation time set to the beginning of time period at T3. SS shall transmit the whole message such that it will be available at the UE no later than a period equals to the RRC procedure delay (= 80 ms) prior to the beginning of T3.
- 8) After 5 seconds from the beginning of time period T2, the SS shall switch the power settings from T2 to T3
- 9) UE shall transmit a PHYSICAL CHANNEL RECONFIGURATION COMPLETE message on the UL DCCH of cell 2. If the UE transmits the UL DPCCH to cell 2 less than 110 ms from the beginning of time period T3 then the number of successful tests is increased by one.
- 10) After 5 seconds from the beginning of time period T3, the UE is switched off. Any timing information of cell 2 is deleted in the UE.
- 11) Repeat step 1-10 [TBD] times

Specific Message Contents

All messages indicated above shall use the same content as described in the default message content in clause 9 of 34.108 [3], with the following exceptions:

MEASUREMENT CONTROL message (step 4):

Information Element/Group name	Value/Remark
Message Type (10.2.17)	
UE information elements -RRC transaction identifier -Integrity check info	0 Not Present
Measurement Information elements -Measurement Identity -Measurement Command (10.3.7.46) -Measurement Reporting Mode (10.3.7.49) -Measurement Report Transfer Mode -Periodical Reporting / Event Trigger Reporting Mode -Additional measurements list (10.3.7.1)	1 Modify AM RLC Event trigger Not Present
-CHOICE <i>Measurement type</i> -Intra-frequency measurement (10.3.7.36) -Intra-frequency measurement objects list (10.3.7.33) -Intra-frequency measurement quantity (10.3.7.38) -Filter coefficient (10.3.7.9) -CHOICE mode -Measurement quantity -Intra-frequency reporting quantity (10.3.7.41)	Intra-frequency measurement Not Present 0 FDD CPICH_Ec/N0
-Reporting quantities for active set cells (10.3.7.5) -SFN-SFN observed time difference reporting indicator -Cell synchronisation information reporting indicator -Cell Identity reporting indicator -CHOICE mode -CPICH Ec/N0 reporting indicator -CPICH RSCP reporting indicator -Pathloss reporting indicator	No report TRUE (Note 1) TRUE FDD TRUE TRUE TRUE
-Reporting quantities for monitored set cells (10.3.7.5) -SFN-SFN observed time difference reporting indicator -Cell synchronisation information reporting indicator -Cell Identity reporting indicator -CHOICE mode -CPICH Ec/N0 reporting indicator -CPICH RSCP reporting indicator -Pathloss reporting indicator	No report TRUE (Note 1) TRUE FDD TRUE TRUE TRUE
-Reporting quantities for detected set cells (10.3.7.5)	Not Present
-Reporting cell status (10.3.7.61) -Measurement validity (10.3.7.51) -CHOICE report criteria -Intra-frequency measurement reporting criteria (10.3.7.39) -Parameters required for each event	Not Present Not Present Intra-frequency measurement reporting criteria 2
-Intra-frequency event identity -Triggering condition 2 -Reporting Range Constant -Cells forbidden to affect Reporting Range -W -Hysteresis -Threshold used frequency -Reporting deactivation threshold -Replacement activation threshold -Time to trigger -Amount of reporting -Reporting interval -Reporting cell status	Event 1A Active set cells and monitored set cells 3 dB Not Present 1.0 0 dB Not Present 0 Not Present 0 ms Infinity 0 ms (Note 2) Not Present
-Intra-frequency event identity -Triggering condition 1 -Reporting Range Constant -Cells forbidden to affect Reporting Range -W -Hysteresis -Threshold used frequency -Reporting deactivation threshold -Replacement activation threshold -Time to trigger	Event 1B Active set cells and monitored set cells 3 dB Not Present 1.0 0 dB Not Present Not Present Not Present 0 ms

Information Element/Group name	Value/Remark
-Amount of reporting -Reporting interval -Reporting cell status	Not Present Not Present Not Present
Physical channel information elements -DPCH compressed mode status info (10.3.6.34)	Not Present
Note 1: The SFN-CFN observed time difference is calculated from the OFF and Tm parameters contained in the IE "Cell synchronisation information", TS 25.331, clause 10.3.7.6. According to TS 25.331, 8.6.7.7, this IE is included in MEASUREMENT REPORT if IE "Cell synchronisation information reporting indicator" in IE "Cell reporting quantities" TS 25.331, clause 10.3.7.5 is set to TRUE in MEASUREMENT CONTROL.	
Note 2: Reporting interval = 0 ms means no periodical reporting	

PHYSICAL CHANNEL RECONFIGURATION message (step 7):

Information Element	Value/Remark
Message Type	
UE Information Elements	
-RRC transaction identifier	0
-Integrity check info	Not Present
-Integrity protection mode info	Not Present
-Ciphering mode info	Not Present
-Activation time	At T3
-New U-RNTI	Not Present
-New C-RNTI	Not Present
-RRC State Indicator	CELL_DCH
-UTRAN DRX cycle length coefficient	Not Present
CN Information Elements	
-CN Information info	Not Present
UTRAN mobility information elements	
-URA identity	Not Present
RB information elements	
-Downlink counter synchronisation info	Not Present
PhyCH information elements	
-Frequency info (10.3.6.36)	
-CHOICE mode	FDD
-UARFCN uplink(Nu)	Same uplink UARFCN as used for cell 2
-UARFCN downlink(Nd)	Same downlink UARFCN as used for cell 2
Uplink radio resources	
-Maximum allowed UL TX power	33 dBm
-CHOICE <i>channel requirement</i>	Uplink DPCH info
-Uplink DPCH info (10.3.6.88)	
-Uplink DPCH power control info (10.3.6.91)	
-CHOICE mode	FDD
-DPCCH power offset	-6dB
- PC Preamble	1 frame
- SRB delay	7 frames
- Power Control Algorithm	Algorithm1
- TPC step size	1dB
-CHOICE mode	FDD
-Scrambling code type	Long
-Scrambling code number	0 (0 to 16777215)
-Number of DPDCH	Not Present(1)
-Spreading factor	64
-TFCI existence	TRUE
-Number of FBI bit	Not Present(0)
-Puncturing Limit	TBD
Downlink radio resources	
-CHOICE <i>mode</i>	FDD
-Downlink PDSCH information	Not Present
-Downlink information common for all radio links (10.3.6.24)	
-Downlink DPCH info common for all RL (10.3.6.18)	
-Timing indicator	Initialise
-CFN-targetSFN frame offset	Not Present
-Downlink DPCH power control information (10.3.6.23)	
-DPC mode	0 (single)
-CHOICE mode	FDD
-Power offset $P_{\text{Pilot-DPDCH}}$	TBD
-DL rate matching restriction information	Not Present
-Spreading factor	128
-Fixed or Flexible Position	Fixed
-TFCI existence	TRUE
-CHOICE SF	128
-Number of bits for Pilot bits(SF=128,256)	8
-CHOICE mode	FDD
-DPCH compressed mode info (10.3.6.33)	Not Present
-TX Diversity mode (10.3.6.86)	None
-SSDT information (10.3.6.77)	Not Present
-Default DPCH Offset Value (10.3.6.16)	0
-Downlink information per radio link list	1
-Downlink information for each radio link (10.3.6.27)	

Information Element	Value/Remark
-CHOICE mode	FDD
-Primary CPICH info (10.3.6.60)	
-Primary scrambling code	350
-PDSCH with SHO DCH info (10.3.6.47)	Not Present
-PDSCH code mapping (10.3.6.43)	Not Present
-Downlink DPCH info for each RL (10.3.6.21)	
-CHOICE mode	FDD
-Primary CPICH usage for channel estimation	Primary CPICH may be used
-DPCH frame offset	0 chips
-Secondary CPICH info	Not Present
-DL channelisation code	
-Secondary scrambling code	1
-Spreading factor	128
-Code number	0
-Scrambling code change	No change
-TPC combination index	0
-SSDT Cell Identity	Not Present
-Closed loop timing adjustment mode	Not Present
-SCCPCH information for FACH (10.3.6.70)	Not Present

MEASUREMENT REPORT message for Inter frequency test cases

This message is common for all inter frequency test cases in clause 8.7 and is described in Annex I.

8.3.2.1.5 Test requirements

For the test to pass, the total number of successful tests shall be more than 90% with a confidence level of [FFS]% of the cases.

Note: If the above Test Requirement differs from the Minimum Requirement then the Test Tolerance applied for this test is non-zero. The Test Tolerance for this test is defined in clause F.2 and the explanation of how the Minimum Requirement has been relaxed by the Test Tolerance is given in clause F.4.

8.3.2.2 FDD/FDD Hard Handover to inter-frequency cell

8.3.2.2.1 Definition and applicability

The hard handover delay is defined as the time from the end of the last TTI containing an RRC message implying hard handover to the transmission of the new uplink DPCCCH.

The requirements and this test apply to the FDD UE.

8.3.2.2.2 Minimum requirement

The interruption time shall be less than 140 ms in CELL_DCH state in the dual carrier case. The rate of correct handovers observed during repeated tests shall be at least 90% with a confidence level of [FFS]%.

The hard handover delay D_{handover} equals the RRC procedure delay defined in TS 25.331 clause 13.5.2 plus the interruption time stated in TS 25.133 clause 5.2.2.2 as follows:

If inter-frequency hard handover is commanded and the UE needs compressed mode to perform inter-frequency measurements, the interruption time shall be less than $T_{\text{interrupt}2}$

$$T_{\text{interrupt}2} = T_{\text{IU}} + 40 + 50 * \text{KC} + 150 * \text{OC} + 10 * F_{\text{max}} \text{ ms}$$

In the interruption requirement $T_{\text{interrupt}2}$ a cell is known if:

- the cell has been measured by the UE during the last 5 seconds.

The phase reference is the primary CPICH.

The normative reference for this requirement is TS 25.133 [2] clauses 5.2.2 and A.5.2.2.

8.3.2.2.3 Test purpose

To verify that the UE meets the minimum requirement.

8.3.2.2.4 Method of test

8.3.2.2.4.1 Initial conditions

Test environment: normal; see clauses G.2.1 and G.2.2.

Frequencies to be tested: mid range; see clause G.2.4.

The test parameters are given in table 8.3.2.2.1 and 8.3.2.2.2 below. The test consists of three successive time periods, with a time duration of T1, T2 and T3 respectively. In the measurement control information it is indicated to the UE that event-triggered reporting with Event 2C shall be used. The CPICH E_c/I_0 of the best cell on the unused frequency shall be reported together with Event 2C reporting. At the start of time duration T1, the UE may not have any timing information of cell 2.

UTRAN shall send a PHYSICAL CHANNEL RECONFIGURATION with activation time at beginning of T3 with one active cell, cell 2. The Physical Channel reconfiguration message shall be sent to the UE so that the whole message is available at the UE the RRC procedure delay prior to the beginning of T3. The RRC procedure delay is defined in TS 25.331 [8].

N312 shall have the smallest possible value i.e. only one insync is required.

Table 8.3.2.2.1: General test parameters for Handover to inter-frequency cell

Parameter		Unit	Value	Comment
DCH parameters			DL and UL Reference Measurement Channel 12.2 kbps	As specified in clause C.3.1 and C.2.1
Power Control			On	
Target quality value on DTCH		BLER	0.01	
Compressed mode			A.22 set 1	As specified in TS 34.121 clause C.5.
Initial conditions	Active cell		Cell 1	
	Neighbour cell		Cell 2	
Final conditions	Active cell		Cell 2	
Threshold non used frequency		dB	-18	Absolute E_c/I_0 threshold for event 2C
Reporting range		dB	4	Applicable for event 1A
Hysteresis		dB	0	
W			1	Applicable for event 1A
W non-used frequency			1	Applicable for event 2C
Reporting deactivation threshold			0	Applicable for event 1A
Time to Trigger		ms	0	
Filter coefficient			0	
T1		s	5	
T2		s	10	
T3		s	5	

Table 8.3.2.2.2: Cell Specific parameters for Handover to inter-frequency cell

Parameter	Unit	Cell 1			Cell 2		
		T1	T2	T3	T1	T2	T3
UTRA RF Channel Number		Channel 1			Channel 2		
CPICH_Ec/I _{or}	dB	-10			-10		
PCCPCH_Ec/I _{or}	dB	-12			-12		
SCH_Ec/I _{or}	dB	-12			-12		
PICH_Ec/I _{or}	dB	-15			-15		
DPCH_Ec/I _{or}	dB	Note1	Note1	Note3	N/A	N/A	Note1
OCNS		Note2	Note2	Note2	-0.941	-0.941	Note2
\hat{I}_{or}/I_{oc}	dB	0			-Infinity	-1.8	-1.8
I_{oc}	dBm/ 3.84 MHz	-70					
CPICH_Ec/I _o	dB	-13			-Infinity	-14	
Propagation Condition		AWGN					
Note 1: The DPCH level is controlled by the power control loop							
Note 2: The power of the OCNS channel that is added shall make the total power from the cell to be equal to I_{or} .							
Note 3: The DPCH may not be power controlled by the power control loop.							

8.3.2.2.4.2 Procedure

- 1) The RF parameters are set up according to T1.
- 2) The UE is switched on.
- 3) A call is set up according to the test procedure specified in TS 34.108 [3] subclause 7.3.4 with Compressed mode parameters as in Table 8.3.2.2.1.
- 4) SS shall transmit a MEASUREMENT CONTROL messages.
- 5) 5 seconds after step4 has completed, the SS shall switch the power settings from T1 to T2
- 6) UE shall transmit a MEASUREMENT REPORT message triggered by event 2C
- 7) SS shall transmit a PHYSICAL CHANNEL RECONFIGURATION message with activation time at the beginning of time period T3. SS shall transmit the whole message such that will be is available at the UE no later than a period equals to the RRC procedure delay (= 80 ms) prior to the beginning of T3.
- 8) After 10 seconds from the beginning of time period T2, the SS shall switch the power settings from T2 to T3
- 9) UE shall transmit a PHYSICAL CHANNEL RECONFIGURATION COMPLETE message on the UL DCCH of cell 2. If the UE transmits the UL DPCCH to cell 2 less than 140 ms from the beginning of time period T3 then the number of successful tests is increased by one.
- 10) After 5 seconds from the beginning of time period T3, the UE is switched off. Any timing information of cell 2 is deleted in the UE.
- 11) Repeat step 1-10 [TBD] times

Specific Message Contents

All messages indicated below shall use the same content as described in the default message content in clause 9 of 34.108 [3], with the following exceptions:

MEASUREMENT CONTROL message, event 2C (step 4):

Information Element/Group name	Value/Remark
Message Type (10.2.17)	
UE information elements	
-RRC transaction identifier	0
-Integrity check info	Not Present
Measurement Information elements	
-Measurement Identity	2
-Measurement Command (10.3.7.46)	Setup
-Measurement Reporting Mode (10.3.7.49)	AM RLC
-Periodical Reporting / Event Trigger Reporting Mode	Event trigger
-Additional measurements list (10.3.7.1)	Not Present
-CHOICE <i>Measurement type</i>	Inter-frequency measurement
-Inter-frequency measurement (10.3.7.16)	
-Inter-frequency measurement objects list (10.3.7.13)	
- CHOICE Inter-frequency cell removal	Not Present
- New Inter frequency cells	
- Inter frequency cell id	0
- Frequency info	
- CHOICE mode	FDD
- UARFCN uplink(Nu)	Not Present
- UARFCN downlink(Nd)	Same frequency as "Channel2" in Table 8.3.2.2.2
- Cell info	
- Cell individual offset	Not Present
- Reference time difference to cell	Not Present
- Read SFN indicator	TRUE
- CHOICE mode	FDD
- Primary CPICH info	
- Primary scrambling code	Set to Primary scrambling code of Cell2
- Primary CPICH Tx Power	Set to Primary CPICH Tx Power of Cell2 described in Table 8.3.2.2.2
- Tx Diversity Indicator	FALSE
- Cell Selection and Re-selection info	Set to Cell Selection and Re-selection info of Cell2
- Cell for measurement	Not Present
-Inter-frequency measurement quantity (10.3.7.18)	
-CHOICE reporting criteria	Inter-frequency reporting criteria
-Inter-frequency reporting criteria	
-Filter coefficient	0
-CHOICE mode	FDD
-Measurement quantity for frequency quality estimate	CPICH Ec/N0
-Inter-frequency reporting quantity (10.3.7.21)	
-UTRA Carrier RSSI	FALSE
-Frequency quality estimate	FALSE
-Non frequency related cell reporting quantities (10.3.7.5)	
-SFN-SFN observed time difference reporting indicator	Type 1
-Cell synchronisation information reporting indicator	TRUE
-Cell Identity reporting indicator	TRUE
-CHOICE mode	FDD
-CPICH Ec/N0 reporting indicator	TRUE
-CPICH RSCP reporting indicator	TRUE
-Pathloss reporting indicator	TRUE
-Reporting cell status (10.3.7.61)	
-CHOICE reported cell	Report cells within monitored set on non-used frequency
-Maximum number of reported cells per reported non-used frequency	1
-Measurement validity (10.3.7.51)	Not Present
-Inter-frequency set update (10.3.7.22)	Not Present
-CHOICE report criteria	Inter-frequency measurement reporting criteria
-Inter-frequency measurement reporting criteria (10.3.7.19)	
-Parameters required for each event	1
-Inter-frequency event identity (10.3.7.14)	Event 2C
-Threshold used frequency	Not Present

Information Element/Group name	Value/Remark
-W used frequency -Hysteresis -Time to trigger -Reporting cell status (10.3.7.61) -CHOICE reported cell -Maximum number of reported cells per reported non-used frequency -Parameters required for each non-used frequency -Threshold non-used frequency -W non-used frequency	Not Present 0 dB 0 ms Report cells within monitored set on non-used frequency 1 1 -18 dB 1
Physical channel information elements -DPCH compressed mode status info (10.3.6.34)	Not Present

PHYSICAL CHANNEL RECONFIGURATION message (step 7):

Information Element	Value/Remark
Message Type	
UE Information Elements	
-RRC transaction identifier	0
-Integrity check info	Not Present
-Integrity protection mode info	Not Present
-Ciphering mode info	Not Present
-Activation time	At T3
-New U-RNTI	Not Present
-New C-RNTI	Not Present
-RRC State Indicator	CELL_DCH
-UTRAN DRX cycle length coefficient	Not Present
CN Information Elements	
-CN Information info	Not Present
UTRAN mobility information elements	
-URA identity	Not Present
RB information elements	
-Downlink counter synchronisation info	Not Present
>RB with PDCP information list	Not Present
>>RB with PDCP information	Not Present
PhyCH information elements	
-Frequency info (10.3.6.36)	
-CHOICE mode	FDD
-UARFCN uplink(Nu)	Same uplink UARFCN as used for cell 2
-UARFCN downlink(Nd)	Same downlink UARFCN as used for cell 2
Uplink radio resources	
-Maximum allowed UL TX power	33 dBm
-CHOICE <i>channel requirement</i>	Uplink DPCH info
-Uplink DPCH info (10.3.6.88)	
-Uplink DPCH power control info (10.3.6.91)	
-CHOICE mode	FDD
-DPCCH power offset	-6dB
- PC Preamble	1 frame
- SRB delay	7 frames
- Power Control Algorithm	Algorithm1
- TPC step size	1dB
-CHOICE mode	FDD
-Scrambling code type	Long
-Scrambling code number	0 (0 to 16777215)
-Number of DPDCH	Not Present(1)
-Spreading factor	64
-TFCI existence	TRUE
-Number of FBI bit	Not Present(0)
-Puncturing Limit	TBD
Downlink radio resources	
-CHOICE <i>mode</i>	FDD
-Downlink PDSCH information	Not Present
-Downlink information common for all radio links (10.3.6.24)	
-Downlink DPCH info common for all RL (10.3.6.18)	
-Timing indicator	Initialise
-CFN-targetSFN frame offset	Not Present
-Downlink DPCH power control information (10.3.6.23)	
-DPC mode	0 (single)
-CHOICE mode	FDD
-Power offset $P_{\text{Pilot-DPDCH}}$	TBD
-DL rate matching restriction information	Not Present
-Spreading factor	128
-Fixed or Flexible Position	Fixed
-TFCI existence	TRUE
-CHOICE SF	128
-Number of bits for Pilot bits(SF=128,256)	8
-CHOICE mode	FDD
-DPCH compressed mode info (10.3.6.33)	
- Transmission gap pattern sequence	1
- TGPSI	1
- TGPS Status Flag	deactivate

Information Element	Value/Remark
- TGCFN	Not Present
- Transmission gap pattern sequence configuration parameters	Not Present
-TX Diversity mode (10.3.6.86)	None
-SSDT information (10.3.6.77)	Not Present
-Default DPCH Offset Value (10.3.6.16)	0
-Downlink information per radio link list	1
-Downlink information for each radio link (10.3.6.27)	
-CHOICE mode	FDD
-Primary CPICH info (10.3.6.60)	
-Primary scrambling code	350
-PDSCH with SHO DCH info (10.3.6.47)	Not Present
-PDSCH code mapping (10.3.6.43)	Not Present
-Downlink DPCH info for each RL (10.3.6.21)	
-CHOICE mode	FDD
-Primary CPICH usage for channel estimation	Primary CPICH may be used
-DPCH frame offset	0 chips
-Secondary CPICH info	Not Present
-DL channelisation code	
-Secondary scrambling code	1
-Spreading factor	128
-Code number	0
-Scrambling code change	No change
-TPC combination index	0
- SSDT Cell Identity	Not Present
- Closed loop timing adjustment mode	Not Present
- SCCPCH information for FACH (10.3.6.70)	Not Present

MEASUREMENT REPORT message for Inter frequency test cases

This message is common for all inter frequency test cases in clause 8.7 and is described in Annex I.

8.3.2.2.5 Test requirements

For the test to pass, the total number of successful tests shall be more than 90% with a confidence level of [FFS]% of the cases.

Note: If the above Test Requirement differs from the Minimum Requirement then the Test Tolerance applied for this test is non-zero. The Test Tolerance for this test is defined in clause F.2 and the explanation of how the Minimum Requirement has been relaxed by the Test Tolerance is given in clause F.4.

8.3.3 FDD/TDD Handover

8.3.3.1 Definition and applicability

The hard handover delay is defined as the time from the end of the last TTI containing an RRC message implying hard handover to the transmission of the new uplink DPCH.

The requirements and this test apply to the combined FDD and TDD UE.

8.3.3.2 Minimum requirement

The hard handover delay shall be less than 70 ms in CELL_DCH state in the dual carrier case. The rate of correct handovers observed during repeated tests shall be at least 90% with a confidence level of [FFS]%.

The hard handover delay D_{handover} equals the RRC procedure delay defined in TS 25.331 clause 13.5.2 plus the interruption time stated in TS 25.133 clause 5.3.2.2 as follows:

If FDD/TDD handover is commanded, the interruption time shall be less than,

$$T_{\text{interrupt}} = T_{\text{offset}} + T_{\text{UL}} + 30 * F_{\text{SFN}} + 20 * \text{KC} + 180 * \text{UC} \text{ ms}$$

where,

T_{offset}	Equal to 10 ms, the frame timing uncertainty between the old cell and the target cell and the time that can elapse until the appearance of a Beacon channel
T_{UL}	Equal to 10 ms, the time that can elapse until the appearance of the UL timeslot in the target cell
F_{SFN}	Equal to 1 if SFN decoding is required and equal to 0 otherwise
KC	Equal to 1 if a known target cell is indicated in the RRC message implying FDD/TDD handover and equal to 0 otherwise
UC	Equal to 1 if an unknown target cell is indicated in the RRC message implying FDD/TDD handover and equal to 0 otherwise

An inter-frequency TDD target cell shall be considered known by the UE, if the target cell has been measured by the UE during the last 5 seconds.

The phase reference is the primary CPICH.

The normative reference for this requirement is TS 25.133 [2] clauses 5.3.2 and A.5.3.2.

8.3.3.3 Test purpose

To verify that the UE meets the minimum requirement.

8.3.3.4 Method of test

8.3.3.4.1 Initial conditions

Test environment: normal; see clauses G.2.1 and G.2.2.

Frequencies to be tested: mid range; see clause G.2.4.

The test parameters are given in Table 8.3.2.2.1 and 8.3.2.2.2 below. The test consists of three successive time periods, with a time duration of T1, T2 and T3 respectively. In the measurement control information it is indicated to the UE that event-triggered reporting with Event 2C shall be used. The Primary CCPCH RSCP of the best cell on the unused frequency shall be reported together with Event 2C reporting. At the start of time duration T1, the UE may not have any timing information of cell 2.

UTRAN shall send a PHYSICAL CHANNEL RECONFIGURATION with activation time at beginning of T3 with one active cell, cell 2. The Physical Channel reconfiguration message shall be sent to the UE so that the whole message is available at the UE the RRC procedure delay prior to the beginning of T3. The RRC procedure delay is defined in TS 25.133 [2].

The UL DPCH in cell 2 shall be transmitted in timeslot 10.

Table 8.3.3.1: General test parameters for Handover to TDD cell

Parameter		Unit	Value	Comment
DCH parameters			DL Reference Measurement Channel 12.2 kbps	As specified in TS 34.121 clause C.3.1 and in TS 34.122 clause C.2.2
Power Control			On	
Target quality value on DTCH		BLER	0.01	
Compressed mode			A.22 set 3	As specified in TS 34.121 clause C.5
Initial conditions	Active cell		Cell 1	FDD cell
	Neighbour cell		Cell 2	TDD cell
Final condition	Active cell		Cell 2	TDD cell
O		dB	0	Cell individual offset. This value shall be used for all cells in the test.
Hysteresis		dB	0	Hysteresis parameter for event 2C
Time to Trigger		ms	0	
Threshold non-used frequency		dBm	-75	Applicable for Event 2C
Filter coefficient			0	
Monitored cell list size			6 FDD neighbours on Channel 1 6 TDD neighbours on Channel 2	
T _{SI}		s	1.28	The value shall be used for all cells in the test
T1		s	5	
T2		s	15	
T3		s	5	

Table 8.3.3.2: Cell Specific parameters for Handover to TDD cell (cell 1)

Parameter	Unit	Cell 1	
		T1, T2	T3
UTRA RF Channel Number		Channel 1	
CPICH_Ec/I _{or}	dB	-10	
P-CCPCH_Ec/I _{or}	dB	-12	
SCH_Ec/I _{or}	dB	-12	
PICH_Ec/I _{or}	dB	-15	
DPCH_Ec/I _{or}	dB	Note 1	n.a.
OCNS_Ec/I _{or}	dB	Note 2	
\hat{I}_{or}/I_{oc}	dB	0	
I_{oc}	dBm/3.84 MHz	-70	
CPICH_Ec/I _o	dB	-13	
Propagation Condition		AWGN	
Note 1: The DPCH level is controlled by the power control loop			
Note 2: The power of the OCNS channel that is added shall make the total power from the cell to be equal to I _{or}			

Table 8.3.3.3: Cell Specific parameters for Handover to TDD cell (cell 2)

Parameter	Unit	Cell 2								
		0			2			8		
DL timeslot number		T1	T2	T3	T1	T2	T3	T1	T2	T3
UTRA RF Channel Number		Channel 2								
P-CCPCH_Ec/I _{or}	dB	-3			n.a.			n.a.		
PICH_Ec/I _{or}	dB	n.a.			n.a.			-3		
SCH_Ec/I _{or}	dB	-9			n.a.			-9		
SCH_t _{offset}	dB	5			n.a.			5		
DPCH_Ec/I _{or}	dB	n.a.			n.a.		Note 1	n.a.		
OCNS_Ec/I _{or}	dB	-3.12			0		Note 2	-3.12		
\hat{I}_{or}/I_{oc}	dB	-Inf	6		-Inf	6		-Inf	6	
P-CCPCH RSCP	dBm	-Inf	-67		n.a.			n.a.		
I_{oc}	dBm/3.84 MHz	-70								
Propagation Condition		AWGN								
Note 1: The DPCH level is controlled by the power control loop										
Note 2: The power of the OCNS channel that is added shall make the total power from the cell to be equal to I _{or} .										
Note that the transmit energy per PN chip for the SCH is averaged over the 256 chip duration when the SCH is present in the time slot.										

8.3.3.4.2 Procedure

- 1) The RF parameters are set up according to T1.
- 2) The UE is switched on.
- 3) A call is set up according to the test procedure specified in TS 34.108 [3] subclause 7.3.4 with Compressed mode parameters as in Table 8.3.2.2.1.
- 4) SS shall transmit a MEASUREMENT CONTROL message.
- 5) After 5 seconds, the SS shall switch the power settings from T1 to T2
- 6) UE shall transmit a MEASUREMENT REPORT message triggered by event 2C
- 7) SS shall transmit a PHYSICAL CHANNEL RECONFIGURATION message with activation time at T3

- 8) After 10 seconds, the SS shall switch the power settings from T2 to T3
- 9) UE shall transmit a PHYSICAL CHANNEL RECONFIGURATION COMPLETE message on the UL DCCH of cell 2. If the UE transmits the UL DPCCH to cell 2 less than 70 ms from the beginning of time period T3 then the number of successful tests is increased by one.
- 10) After 5 seconds, the UE is switched off. Any timing information of cell 2 is deleted in the UE.
- 11) Repeat step 1-10 [TBD] times

Specific Message Contents

All messages indicated above shall use the same content as described in the default message content in clause 9 of 34.108 [3], with the following exceptions:

MEASUREMENT CONTROL message, event 2C (step 4):

Information Element/Group name	Value/Remark
Message Type (10.2.17)	
UE information elements -RRC transaction identifier -Integrity check info	0 Not Present
Measurement Information elements -Measurement Identity -Measurement Command (10.3.7.46) -Measurement Reporting Mode (10.3.7.49) -Measurement Report Transfer Mode -Periodical Reporting / Event Trigger Reporting Mode -Additional measurements list (10.3.7.1)	1 Modify AM RLC Event trigger Not Present
-CHOICE <i>Measurement type</i> -Inter-frequency measurement (10.3.7.16) -Inter-frequency measurement objects list (10.3.7.13) -Inter-frequency measurement quantity (10.3.7.18) -CHOICE <i>reporting criteria</i> -Inter-frequency reporting criteria -Filter coefficient -CHOICE <i>mode</i> -Measurement quantity for frequency quality estimate	Inter-frequency measurement Not Present Inter-frequency reporting criteria 0 TDD Primary CCPCH RSCP
-Inter-frequency reporting quantity (10.3.7.21) -UTRA Carrier RSSI -Frequency quality estimate -Non frequency related cell reporting quantities (10.3.7.5) -SFN-SFN observed time difference reporting indicator -Cell synchronisation information reporting indicator -Cell Identity reporting indicator -CHOICE <i>mode</i> -Timeslot ISCP reporting indicator -Proposed TGSN reporting required -Primary CCPCH RSCP reporting indicator -Pathloss reporting indicator	FALSE FALSE Type 1 TRUE TRUE TDD TRUE FALSE TRUE TRUE
-Reporting cell status (10.3.7.61) -CHOICE <i>reported cell</i> -Maximum number of reported cells per reported non-used frequency -Measurement validity (10.3.7.51) -Inter-frequency set update (10.3.7.22) -CHOICE <i>report criteria</i>	Report cells within monitored set on non-used frequency 1 Not Present Not Present Inter-frequency measurement reporting criteria
-Inter-frequency measurement reporting criteria (10.3.7.19) -Parameters required for each event -Inter-frequency event identity (10.3.7.14) -Threshold used frequency -W used frequency -Hysteresis -Time to trigger -Reporting cell status (10.3.7.61) -CHOICE <i>reported cell</i> -Maximum number of reported cells per reported non-used frequency -Parameters required for each non-used frequency -Threshold non-used frequency -W non-used frequency	1 Event 2C Not Present Not Present 0 dB 0 ms Report cells within monitored set on non-used frequency 1 1 -80 dBm 1
Physical channel information elements -DPCH compressed mode status info (10.3.6.34)	Not Present

PHYSICAL CHANNEL RECONFIGURATION message (step 7):

Information Element	Value/Remark
Message Type	
UE Information Elements	
-RRC transaction identifier	0
-Integrity check info	Not Present
-Integrity protection mode info	Not Present
-Ciphering mode info	Not Present
-Activation time	At T3
-New U-RNTI	Not Present
-New C-RNTI	Not Present
-RRC State Indicator	CELL_DCH
-UTRAN DRX cycle length coefficient	Not Present
CN Information Elements	
-CN Information info	Not Present
UTRAN mobility information elements	
-URA identity	Not Present
RB information elements	
-Downlink counter synchronisation info	Not Present
-RB with PDCP information list	Not Present
-RB with PDCP information	Not Present
PhyCH information elements	
-Frequency info (10.3.6.36)	TDD
-CHOICE <i>mode</i>	Same UARFCN as used for cell 2
-UARFCN (Nt)	
Uplink radio resources	
-Maximum allowed UL TX power	33 dBm
-CHOICE <i>channel requirement</i>	Uplink DPCH info
-Uplink DPCH info (10.3.6.88)	
-Uplink DPCH power control info (10.3.6.91)	
-CHOICE <i>mode</i>	TDD
-CHOICE <i>TDD option</i>	3.84 Mcps TDD
-UL Target SIR	Not Present
-CHOICE <i>UL OL PC info</i>	Individually signalled
-CHOICE <i>TDD option</i>	3.84 Mcps TDD
-Individual Timeslot interference info	1
-Individual timeslot interference (10.3.6.38)	
-Timeslot Number (10.3.6.84)	
-CHOICE <i>TDD option</i>	3.84 Mcps TDD
-Timeslot number	10
- UL Timeslot Interference	-90 dBm
-CHOICE <i>mode</i>	TDD
-Uplink timing advance control (10.3.6.96)	
-CHOICE <i>Timing Advance</i>	Disabled
-UL CCTrCH list	1
-UL Target SIR	TBD dB
-Time Info (10.3.6.83)	
-Activation Time	T3
-Duration	Infinite
-Common timeslot info	Not Present
-Uplink DPCH timeslots and codes (10.3.6.94)	
-Dynamic SF Usage	False
-First individual timeslot info (10.3.6.37)	
-Timeslot Number (10.3.6.84)	
-CHOICE <i>TDD option</i>	3.84 Mcps
-Timeslot number	10
-TFCl existence	True
-Midamble shift and burst type (10.3.6.41)	
-CHOICE <i>TDD option</i>	3.84 Mcps
-CHOICE <i>Burst Type</i>	Type 1
-Midamble Allocation Mode	Default
-Midamble configuration burst type 1 and 3	16
-Midamble shift	Not present
-CHOICE <i>TDD option</i>	3.84 Mcps
-First timeslot code list	1
-Channelisation code	8/1
-CHOICE <i>more timeslots</i>	No more timeslots

Information Element	Value/Remark
Downlink radio resources	
-CHOICE <i>mode</i>	TDD
-Downlink information common for all radio links (10.3.6.24)	
-Downlink DPCH info common for all RL (10.3.6.18)	
-Timing indicator	Initialise
-CFN-targetSFN frame offset	Not Present
-Downlink DPCH power control information (10.3.6.23)	
-CHOICE <i>mode</i>	TDD
-TPC Step size	1 dB
-CHOICE <i>mode</i>	TDD
-CHOICE <i>mode</i>	TDD
-CHOICE <i>TDD option</i>	3.84 Mcps
-TX Diversity mode (10.3.6.86)	None
-Default DPCH Offset Value (10.3.6.16)	0
-Downlink information per radio link list	1
-Downlink information for each radio link (10.3.6.27)	
-CHOICE <i>mode</i>	TDD
-Primary CCPCH info (10.3.6.57)	
- CHOICE <i>mode</i>	TDD
- CHOICE <i>TDD option</i>	3.84 Mcps
- CHOICE <i>sync case</i>	Case 2
- Timeslot	0
- Cell parameters ID	20
- SCTD indicator	False
-Downlink DPCH info for each RL (10.3.6.21)	
-CHOICE <i>mode</i>	TDD
- DL CCTrCH list	1
-TFCS ID	Not Present
-Time Info (10.3.6.83)	
-Activation Time	T3
-Duration	Infinite
-Common timeslot info	Not Present
- Downlink DPCH timeslots and codes (10.3.6.32)	
- First individual timeslot info (10.3.6.37)	
- Timeslot Number (10.3.6.84)	
- CHOICE <i>TDD option</i>	3.84 Mcps
- Timeslot number	2
- TFCI existence	True
- Midamble shift and burst type (10.3.6.41)	
- CHOICE <i>TDD option</i>	3.84 Mcps
- CHOICE <i>Burst Type</i>	Type 1
- Midamble Allocation Mode	Default
- Midamble configuration burst type 1 and 3	16
- Midamble shift	Not present
- CHOICE <i>TDD option</i>	3.84 Mcps
- First timeslot channelisation codes (10.3.6.17)	
- CHOICE <i>codes representation</i>	Consecutive codes
- First channelisation code	16/1
- Last channelisation code	16/2
- CHOICE <i>more timeslots</i>	No more timeslots
- SCCPCH information for FACH (10.3.6.70)	Not Present

MEASUREMENT REPORT message for Inter frequency test cases

This message is common for all inter frequency test cases in clause 8.7 and is described in Annex I.

8.3.3.5 Test requirements

For the test to pass, the total number of successful tests shall be more than 90% with a confidence level of [FFS]% of the cases.

Note: If the above Test Requirement differs from the Minimum Requirement then the Test Tolerance applied for this test is non-zero. The Test Tolerance for this test is defined in clause F.2 and the explanation of how the Minimum Requirement has been relaxed by the Test Tolerance is given in clause F.4.

8.3.4 Inter-system Handover from UTRAN FDD to GSM

8.3.4.1 Definition and applicability

The UTRAN to GSM cell handover delay is defined as the time from the end of the last TTI containing an RRC message implying hard handover to the transmission on the channel of the new RAT.

The requirements and this test apply to the combined FDD and GSM UE.

8.3.4.2 Minimum requirement

The hard handover delay shall be less than 40 ms. The rate of correct handovers observed during repeated tests shall be at least 90% with a confidence level of [FFS]%.

The hard handover delay as listed in table 8.3.4.1 equals the RRC procedure delay plus the interruption time listed in table 8.3.4.2. The UE shall process the RRC procedures for the RRC HANDOVER FROM UTRAN COMMAND within 50 ms.

Table 8.3.4.1: FDD/GSM handover - handover delay

UE synchronisation status	handover delay [ms]
The UE has synchronised to the GSM cell before the HANDOVER FROM UTRAN COMMAND is received	90
The UE has not synchronised to the GSM cell before the HANDOVER FROM UTRAN COMMAND is received	190

Table 8.3.4.2: FDD/GSM handover - interruption time

Synchronisation status	Interruption time [ms]
The UE has synchronised to the GSM cell before the HANDOVER FROM UTRAN COMMAND is received	40
The UE has not synchronised to the GSM cell before the HANDOVER FROM UTRAN COMMAND is received	140

The normative reference for this requirement is TS 25.133 [2] clauses 5.4.2 and A.5.4.

8.3.4.3 Test purpose

To verify that the UE meets the minimum requirement.

8.3.4.4 Method of test

8.3.4.4.1 Initial conditions

Test environment: normal; see clauses G.2.1 and G.2.2.

Frequencies to be tested: mid range; see clause G.2.4.

[Editor's Note: Annex G.2 must be specified also for GSM; for instance as a reference to TS 51.010-1 clause A1.2]

The test parameters are given in table 8.3.4.3, 8.3.4.4 and 8.3.4.5 below. In the measurement control information it is indicated to the UE that event-triggered reporting with Event 3C shall be used.. The test consists of three successive time periods, with a time duration of T1, T2 and T3 respectively. At the start of time duration T1, the UE may not have any timing information of cell 2.

UTRAN shall send a HANDOVER FROM UTRAN COMMAND well in advance to T3 with activation time at T3. In GSM Handover command contained in that message, IE starting time shall not be included.

The requirements are also applicable for a UE not requiring compressed mode, in which case no compressed mode pattern should be sent for the parameters specified in table 8.3.4.3.

Table 8.3.4.3: General test parameters for Correct reporting of GSM neighbours in AWGN propagation condition

Parameter	Unit	Value	Comment
DCH parameters		DL Reference Measurement Channel 12.2 kbps	As specified in TS 34.121 clause C.3.1
Power Control		On	
Target quality value on DTCH	BLER	0.01	
Compressed mode patterns			Only applicable for UE requiring compressed mode patterns
- GSM carrier RSSI measurement		DL Compressed mode reference pattern 2 in Set 2	As specified in TS 34.121 [1] clause C.5, table C.5.2
- GSM Initial BSIC identification		Pattern 2	As specified in clause TS 25.133 [2] 8.1.2.5.2.1 table 8.7.
- GSM BSIC re-confirmation		Pattern 2	As specified in clause TS 25.133 [2] 8.1.2.5.2.2 table 8.8.
Active cell		Cell 1	
Inter-RAT measurement quantity		GSM Carrier RSSI	
BSIC verification required		Required	
Threshold other system	dBm	-80	Absolute GSM carrier RSSI threshold for event 3B and 3C.
Hysteresis	dB	0	
Time to Trigger	ms	0	
Filter coefficient		0	
Monitored cell list size		24 FDD neighbours on Channel 1 6 GSM neighbours including ARFCN 1	Measurement control information is sent before the compressed mode patterns starts.
N Identify abort		66	Taken from TS 25.133 [2] 8.1.2.5.2.1 table 8.7.
T Reconfirm abort		5.5	Taken from TS 25.133 [2] 8.1.2.5.2.2 table 8.8.
T1	s	20	
T2	s	5	
T3	s	5	

Table 8.3.4.4: Cell Specific Parameters for Handover UTRAN to GSM cell case (cell 1)

Parameter	Unit	Cell 1 (UTRA)
		T1, T2, T3
CPICH_Ec/I _{or}	dB	-10
PCCPCH_Ec/I _{or}	dB	-12
SCH_Ec/I _{or}	dB	-12
PICH_Ec/I _{or}	dB	-15
DCH_Ec/I _{or}	dB	Note 1
OCNS_Ec/I _{or}	dB	Note 2
\hat{I}_{or}/I_{oc}	dB	0
I_{oc}	dBm/3. 84 MHz	-70
CPICH_Ec/I _o	dB	-13
Propagation Condition		AWGN
Note 1: The DPCH level is controlled by the power control loop Note 2: The power of the OCNS channel that is added shall make the total power from the cell to be equal to I _{or} .		

Table 8.3.4.5: Cell Specific Parameters for Handover UTRAN to GSM cell case (cell 2)

Parameter	Unit	Cell 2 (GSM)	
		T1	T2, T3
Absolute RF Channel Number		ARFCN 1	
RXLEV	dBm	-85	-75

8.3.4.4.2 Procedure

- 1) The RF parameters for cell 1 are set up according to T1.
 - 2) The UE is switched on
 - 3) A call is set up according to the test procedure specified in TS 34.108 [3] subclause 7.3.4
 - 4) The RF parameters for cell 2 are set up according to T1 and the SS configures a traffic channel
 - 5) SS shall transmit a MEASUREMENT CONTROL message to cell 1
 - 6) After 20 seconds, the SS shall switch the power settings from T1 to T2
 - 7) UE shall transmit a MEASUREMENT REPORT message triggered by event 2C
 - 8) SS shall transmit a HANDOVER FROM UTRAN COMMAND message with activation time at T3 and indicating the traffic channel of the target GSM cell to the UE through DCCH of the serving UTRAN cell.
 - 9) After 5 seconds, the SS shall switch the power settings from T2 to T3
 - 10) UE shall transmit a burst on the traffic channel of cell 2 implying that it has switched to the GSM cell. The UE sends a HANDOVER ACCESS message. If the UE transmits access bursts on the new DCCH of the target cell less than 40 ms from the beginning of time period T3, then the number of successful tests is increased by one.
- [Editor's note: TS 34.108, 7.3.4 shall specify the messages HANDOVER ACCESS, PHYSICAL INFORMATION, SABM, UA and HANDOVER COMPLETE]
- 11) After 5 seconds, the UE is switched off. Any timing information of cell 2 is deleted in the UE.
 - 12) Repeat step 1-11 [TBD] times

Specific Message Contents

All messages indicated below shall use the same content as described in the default message content in clause 9 of 34.108 [3], with the following exceptions:

MEASUREMENT CONTROL message (step 5):

Information Element/Group name	Value/Remark
Message Type (10.2.17)	
UE information elements	
-RRC transaction identifier	0
-Integrity check info	Not Present
Measurement Information elements	
-Measurement Identity	1
-Measurement Command (10.3.7.46)	Modify
-Measurement Reporting Mode (10.3.7.49)	
-Measurement Report Transfer Mode	AM RLC
-Periodical Reporting / Event Trigger Reporting Mode	Event trigger
-Additional measurements list (10.3.7.1)	Not Present
-CHOICE <i>Measurement type</i>	Inter-RAT measurement
-Inter-RAT measurement (10.3.7.27)	
-Inter-RAT measurement objects list (10.3.7.23)	Not Present
-Inter-RAT measurement quantity (10.3.7.29)	
-Measurement quantity for UTRAN quality estimate (10.3.7.38)	
-Filter coefficient	0
-CHOICE mode	FDD
-Measurement quantity	CPICH Ec/N0
-CHOICE system	GSM
-Measurement quantity	GSM Carrier RSSI
-Filter coefficient	0
-BSIC verification required	Required
-Inter-RAT reporting quantity (10.3.7.32)	Not Present
-Reporting cell status (10.3.7.61)	
-CHOICE reported cell	Report cells within active set or within virtual active set or of the other RAT
-Maximum number of reported cells	2
-CHOICE report criteria	Inter-RAT measurement reporting criteria
-Inter-RAT measurement reporting criteria (10.3.7.30)	
-Parameters required for each event	1
-Inter-RAT event identity (10.3.7.24)	Event 3C
-Threshold own system	Not Present
-W	Not Present
-Threshold other system	-80 dBm
-Hysteresis	0 dB
-Time to trigger	0 ms
-Reporting cell status (10.3.7.61)	
-CHOICE reported cell	Report cells within active set or within virtual active set or of the other RAT
-Maximum number of reported cells	2
Physical channel information elements	
-DPCH compressed mode status info (10.3.6.34)	Not Present

HANDOVER FROM UTRAN COMMAND message (step 8):

Information Element	Value/remark
Message Type	
UE information elements -RRC transaction identifier -Integrity check info -Activation time	0 Not Present At T3
RB information elements -RAB information list -RAB Info	1 Not present
Other information elements -CHOICE System type -Frequency Band -GSM message -Single GSM message -GSM message List	GSM GSM/DCS 1800 Band [TBD] GSM HANDOVER COMMAND formatted as BIT STRING(1..512). The contents of the HANDOVER COMMAND see next table.

HANDOVER COMMAND

Same as the HANDOVER COMMAND for M = 2 in clause 26.6.5.1 of TS 51.010, except that the CHANNEL MODE IE is included with value = speech full rate or half rate version 3

MEASUREMENT REPORT message for Inter-RAT test cases

This message is common for all inter RAT frequency test cases in clause 8.7 and is described in Annex I.

8.3.4.5 Test requirements

For the test to pass, the total number of successful tests shall be more than 90% with a confidence level of [FFS]% of the cases.

Note: If the above Test Requirement differs from the Minimum Requirement then the Test Tolerance applied for this test is non-zero. The Test Tolerance for this test is defined in clause F.2 and the explanation of how the Minimum Requirement has been relaxed by the Test Tolerance is given in clause F.4.

8.3.5 Cell Re-selection in CELL_FACH

8.3.5.1 One frequency present in neighbour list

8.3.5.1.1 Definition and applicability

The cell re-selection delay is defined as the time between the occurrence of an event which will trigger Cell Reselection process and the moment in time when the UE starts sending the preambles on the PRACH for sending RRC CELL UPDATE message to the UTRAN.

8.3.5.1.2 Minimum requirements

The cell re-selection delay shall be less than 1.6 s.

The rate of correct cell reselections observed during repeated tests shall be at least 90%.

If a cell has been detectable at least $T_{\text{identify,intra}}$, the cell reselection delay in CELL_FACH state to a cell in the same frequency shall be less than

$$T_{\text{reselection,intra}} = T_{\text{Measurement_Period Intra}} + T_{\text{IU}} + 20 + T_{\text{SI}} + T_{\text{RA}} \text{ ms}$$

where

$$T_{\text{Measurement_Period Intra}} = 200 \text{ ms.}$$

T_{IU} is the interruption uncertainty when changing the timing from the old to the new cell. T_{IU} can be up to one frame (10 ms).

T_{SI} = The time required for receiving all the relevant system information data according to the reception procedure and the RRC procedure delay of system information blocks defined in 25.331 for a UTRAN cell. 1280 ms is assumed in this test case.

T_{RA} = The additional delay caused by the random access procedure. T_{RA} is a delay is caused by the physical random access procedure described in TS 25.214 clause 6.1. A persistence value is assumed to be 1 in this test case and therefore T_{RA} in this test case is 40 ms.

These requirements assume radio conditions to be sufficient, so reading of system information can be done without errors.

The normative reference for this requirement is TS 25.133 [2] clauses 5.5.2.1.1 and A.5.5.1.

8.3.5.1.3 Test purpose

The purpose of this test is to verify the requirement for the cell re-selection delay in CELL_FACH state in the single carrier case

8.3.5.1.4 Method of test

8.3.5.1.4.1 Initial conditions

Test environment: normal; see clauses G.2.1 and G.2.2.

Frequencies to be tested: mid range; see clause G.2.4.

The test parameters are given in table 8.3.5.1.1 to 8.3.5.1.4. The UE is requested to monitor neighbouring cells on 1 carrier. The maximum repetition period of the relevant system info blocks that needs to be received by the UE to camp on a cell shall be 1280 ms.

Table 8.3.5.1.1: General test parameters for Cell Re-selection in CELL_FACH, one freq. in neighbour list

Parameter		Unit	Value	Comment
Initial condition	Active cell		Cell2	
	Neighbour cells		Cell1, Cell3, Cell4, Cell5, Cell6	
Final condition	Active cell		Cell1	
Access Service Class (ASC#0) – Persistence value		-	1	Selected so that no additional delay is caused by the random access procedure. The value shall be used for all cells in the test.
HCS				Not used
T1		s	15	
T2		s	15	

The transport and physical parameters of the S-CCPCH carrying the FACH are defined in table 8.3.5.1.2 and table 8.3.5.1.3.

Table 8.3.5.1.2: Physical channel parameters for S-CCPCH, one freq. in neighbour list

Parameter	Unit	Level
Channel bit rate	kbps	60
Channel symbol rate	ksps	30
Slot Format #1	-	4
TFCI	-	OFF
Power offsets of TFCI and Pilot fields relative to data field	dB	0

Table 8.3.5.1.3: Transport channel parameters for S-CCPCH, one freq. in neighbour list

Parameter	FACH
Transport Channel Number	1
Transport Block Size	240
Transport Block Set Size	240
Transmission Time Interval	10 ms
Type of Error Protection	Convolution Coding
Coding Rate	1/2
Rate Matching attribute	256
Size of CRC	16
Position of TrCH in radio frame	Fixed

Table 8.3.5.1.4: Cell specific initial conditions for Cell Re-selection in CELL_FACH, one freq. in neighbour list

Parameter	Unit	Cell 1		Cell 2		Cell 3		Cell 4		Cell 5		Cell 6	
		T1	T2	T1	T2	T1	T2	T1	T2	T1	T2	T1	T2
UTRA RF Channel Number		Channel 1		Channel 1		Channel 1		Channel 1		Channel 1		Channel 1	
CPICH_Ec/lor	dB	-10		-10		-10		-10		-10		-10	
PCCPCH_Ec/lor	dB	-12		-12		-12		-12		-12		-12	
SCH_Ec/lor	dB	-12		-12		-12		-12		-12		-12	
PICH_Ec/lor	dB	-15		-15		-15		-15		-15		-15	
S-CCPCH_Ec/lor	dB	-12		-12		-12		-12		-12		-12	
OCNS_Ec/lor	dB	-1.295		-1.295		-1.295		-1.295		-1.295		-1.295	
\hat{I}_{or}/I_{oc}	dB	7.3	10.27	10.27	7.3	0.27	0.27	0.27	0.27	0.27	0.27	0.27	0.27
I_{oc}	dBm/3.84 MHz	-70											
CPICH_Ec/lo	dB	-16	-13	-13	-16	-23	-23	-23	-23	-23	-23	-23	-23
Propagation Condition		AWGN											
Cell_selection_and_reselection_quality_measure		CPICH E _c /N ₀		CPICH E _c /N ₀		CPICH E _c /N ₀		CPICH E _c /N ₀		CPICH E _c /N ₀		CPICH E _c /N ₀	
Qqualmin	dB	-20		-20		-20		-20		-20		-20	
Qrxlevmin	dBm	-115		-115		-115		-115		-115		-115	
UE_TXPWR_MAX_RACH	dBm	21		21		21		21		21		21	
Qoffset 2 _{s, n}	dB	C1, C2: 0 C1, C3: 0 C1, C4: 0 C1, C5: 0 C1, C6: 0	C2, C1: 0 C2, C3: 0 C2, C4: 0 C2, C5: 0 C2, C6: 0	C3, C1: 0 C3, C2: 0 C3, C4: 0 C3, C5: 0 C3, C6: 0	C4, C1: 0 C4, C2: 0 C4, C3: 0 C4, C5: 0 C4, C6: 0	C5, C1: 0 C5, C2: 0 C5, C3: 0 C5, C4: 0 C5, C6: 0	C6, C1: 0 C6, C2: 0 C6, C3: 0 C6, C4: 0 C6, C5: 0						
Qhyst	dB	0		0		0		0		0		0	
Treselection	s	0		0		0		0		0		0	
Sintrasearch	dB	not sent		not sent		not sent		not sent		not sent		not sent	
IE "FACH Measurement occasion info"		not sent		not sent		not sent		not sent		not sent		not sent	

8.3.5.1.4.2 Procedure

- 1) The SS activates cell 1-6 with RF parameters set up according to T1 in table 8.3.5.1.4.
- 2) The UE is switched on.
- 3) An RRC connection is set up according to the signalling sequence in the generic set-up procedure specified in TS 34.108 [3] subclause 7.3.3 to place the UE in CELL_FACH.
- 4) 15 seconds after step3 has completed, the SS shall switch the power settings from T1 to T2 in table 8.3.5.1.4.
- 5) The SS waits for random access requests from the UE. If the UE responds on cell 1 within 1.7 s from the beginning of time period T2 then the number of successful tests is increased by one. And if the SS receive a CELL UPDATE message from the UE, the SS shall transmit a CELL UPDATE CONFIRM.
- 6) After 15 s from the beginning of time period T2, the parameters are changed to that as described for T1 in table 8.3.5.1.4.
- 7) The SS waits for random access requests from the UE. If the UE responds on cell 2 within 1.7 s from the beginning of time period T1 then the number of successful tests is increased by one. And if the SS receive a CELL UPDATE message from the UE, the SS shall transmit a CELL UPDATE CONFIRM.
- 8) After 15 s from the beginning of time period T1, the parameters are changed to that as described for T2.
- 9) Repeat step 5) to 8) [TBD] times.

NOTE: The time required for receiving all the relevant system information data according to the reception procedure and the RRC procedure delay of system information blocks defined in 25.331 for a UTRAN cell. Since the maximum repetition period of the relevant system info blocks that needs to be received by the UE to camp on a cell is 1280ms and the maximum RRC procedure delay for reception system information block is 100ms, 1380 ms is assumed in this test case. Therefore the cell re-selection delay shall be less than 1.7 s.(Minimum requirement + 100ms).

8.3.5.1.5 Test requirements

For the test to pass, the total number of successful attempts shall be more than 90% with a confidence level of [FFS]% of the cases.

Note: If the above Test Requirement differs from the Minimum Requirement then the Test Tolerance applied for this test is non-zero. The Test Tolerance for this test is defined in clause F.2 and the explanation of how the Minimum Requirement has been relaxed by the Test Tolerance is given in clause F.4.

8.3.5.2 Two frequencies present in the neighbour list

8.3.5.2.1 Definition and applicability

The cell re-selection delay is defined as the time between the occurrence of an event which will trigger Cell Reselection process and the moment in time when the UE starts sending the the preambles on the PRACH for sending RRC CELL UPDATE message to the UTRAN.

8.3.5.2.2 Minimum requirements

The cell re-selection delay shall be less than 1.9 s.

The rate of correct cell reselections observed during repeated tests shall be at least 90%.

If a cell has been detectable at least $T_{\text{identify,inter}}$, the cell reselection delay in CELL_FACH state to a FDD cell on a different frequency shall be less than

$$T_{\text{reselection, inter}} = T_{\text{Measurement inter}} + T_{\text{IU}} + 20 + T_{\text{SI}} + T_{\text{RA}} \text{ ms}$$

where

$T_{\text{Measurement_inter}}$ is 480 ms in this case

T_{IU} is the interruption uncertainty when changing the timing from the old to the new cell. T_{IU} can be up to one frame (10 ms).

T_{SI} = The time required for receiving all the relevant system information data according to the reception procedure and the RRC procedure delay of system information blocks defined in 25.331 for a UTRAN cell. 1280 ms is assumed in this test case.

T_{RA} = The additional delay caused by the random access procedure. T_{RA} is a delay is caused by the physical random access procedure described in TS 25.214 clause 6.1. A persistence value is assumed to be 1 in this test case and therefore T_{RA} in this test case is 40 ms.

These requirements assume radio conditions to be sufficient, so that reading of system information can be done without errors.

The normative reference for this requirement is TS 25.133 [2] clauses 5.5.2.1.2 and A.5.5.2.

8.3.5.2.3 Test purpose

The purpose of this test is to verify the requirement for the cell re-selection delay in CELL_FACH state in the single carrier case

8.3.5.2.4 Method of test

8.3.5.2.4.1 Initial conditions

Test environment: normal; see clauses G.2.1 and G.2.2.

Frequencies to be tested: mid range; see clause G.2.4.

The test parameters are given in table 8.3.5.2.1 to 8.3.5.2.4. The UE is requested to monitor neighbouring cells on 2 carriers. The maximum repetition period of the relevant system info blocks that needs to be received by the UE to camp on a cell shall be 1280 ms

Table 8.3.5.2.1: General test parameters for Cell Re-selection in CELL_FACH, two freqs. in neighbour list

Parameter		Unit	Value	Comment
Initial condition	Active cell		Cell2	
	Neighbour cells		Cell1, Cell3, Cell4, Cell5, Cell6	
Final condition	Active cell		Cell1	
Access Service Class (ASC#0) – Persistence value		-	1	Selected so that no additional delay is caused by the random access procedure. The value shall be used for all cells in the test.
HCS				Not used
T1		s	15	
T2		s	15	

The transport and physical parameters of the S-CCPCH carrying the FACH are defined in table 8.3.5.2.2 and table 8.3.5.2.3.

Table 8.3.5.2.2: Physical channel parameters for S-CCPCH, two freqs. in neighbour list

Parameter	Unit	Level
Channel bit rate	kbps	60
Channel symbol rate	ksps	30
Slot Format #1	-	4
TFCI	-	OFF
Power offsets of TFCI and Pilot fields relative to data field	dB	0

Table 8.3.5.2.3: Transport channel parameters for S-CCPCH, two freqs. in neighbour list

Parameter	FACH
Transport Channel Number	1
Transport Block Size	240
Transport Block Set Size	240
Transmission Time Interval	10 ms
Type of Error Protection	Convolution Coding
Coding Rate	$\frac{1}{2}$
Rate Matching attribute	256
Size of CRC	16
Position of TrCH in radio frame	Fixed

Table 8.3.5.2.4: Cell specific initial conditions for Cell re-selection in CELL_FACH state, two freqs. in neighbour list

Parameter	Unit	Cell 1		Cell 2		Cell 3		Cell 4		Cell 5		Cell 6	
		T1	T2	T1	T2	T1	T2	T1	T2	T1	T2	T1	T2
UTRA RF Channel Number		Channel 1		Channel 2		Channel 1		Channel 1		Channel 2		Channel 2	
CPICH_Ec/Ior	dB	-10		-10		-10		-10		-10		-10	
PCCPCH_Ec/Ior	dB	-12		-12		-12		-12		-12		-12	
SCH_Ec/Ior	dB	-12		-12		-12		-12		-12		-12	
PICH_Ec/Ior	dB	-15		-15		-15		-15		-15		-15	
S-CCPCH_Ec/Ior	dB	-12		-12		-12		-12		-12		-12	
OCNS_Ec/Ior	dB	-1.295		-1.295		-1.295		-1.295		-1.295		-1.295	
\hat{I}_{or}/I_{oc}	dB	-1.8	2.2	2.2	-1.8	-6.8	-4.8	-6.8	-4.8	-4.8	-6.8	-4.8	-6.8
I_{oc}	dBm/3.84 MHz	-70											
CPICH_Ec/Io	dB	-15	-13	-13	-15	-20		-20		-20		-20	
Propagation Condition		AWGN											
Cell_selection_and_reselection_quality_measure		CPICH E _c /N ₀		CPICH E _c /N ₀		CPICH E _c /N ₀		CPICH E _c /N ₀		CPICH E _c /N ₀		CPICH E _c /N ₀	
Qqualmin	dB	-20		-20		-20		-20		-20		-20	
Qrxlevmin	dBm	-115		-115		-115		-115		-115		-115	
UE_TXPWR_MAX_RACH	dBm	21		21		21		21		21		21	
Qoffset2 _{s, n}	dB	C1, C2: 0 C1, C3: 0 C1, C4: 0 C1, C5: 0 C1, C6: 0		C2, C1: 0 C2, C3: 0 C2, C4: 0 C2, C5: 0 C2, C6: 0		C3, C1: 0 C3, C2: 0 C3, C4: 0 C3, C5: 0 C3, C6: 0		C4, C1: 0 C4, C2: 0 C4, C3: 0 C4, C5: 0 C4, C6: 0		C5, C1: 0 C5, C2: 0 C5, C3: 0 C5, C4: 0 C5, C6: 0		C6, C1: 0 C6, C2: 0 C6, C3: 0 C6, C4: 0 C6, C5: 0	
Qhyst2	dB	0		0		0		0		0		0	
Treselection	s	0		0		0		0		0		0	
Sintrasearch	dB	not sent		not sent		not sent		not sent		not sent		not sent	
Sintersearch	dB	not sent		not sent		not sent		not sent		not sent		not sent	
IE "FACH Measurement occasion info"		sent		sent		sent		sent		Sent		sent	
FACH Measurement occasion cycle length coefficient		3		3		3		3		3		3	
Inter-frequency FDD measurement indicator		TRUE		TRUE		TRUE		TRUE		TRUE		TRUE	
Inter-frequency TDD measurement indicator		FALSE		FALSE		FALSE		FALSE		FALSE		FALSE	

8.3.5.2.4.2 Procedure

- 1) The RF parameters for cell 1 are set up according to T1 in table 8.3.5.2.5.
- 2) The UE is switched on.
- 3) An RRC connection is set up according to the signalling sequence in the generic set-up procedure specified in TS 34.108 [3] subclause 7.3.3 to place the UE in CELL_FACH.
- 4) 15 seconds after step3 has completed, the SS shall switch the power settings from T1 to T2 in table 8.3.5.2.5.
- 5) The SS waits for random access requests from the UE. If the UE responds on cell 1 within 2.0 s from the beginning of time period T2 then the number of successful tests is increased by one. And if the SS receive a CELL UPDATE message from the UE, the SS shall transmit a CELL UPDATE CONFIRM.

- 6) After 15 s from the beginning of time period T2, the parameters are changed to that as described for T1 in table 8.3.5.2.5.
- 7) The SS waits for random access requests from the UE. If the UE responds on cell 2 within 2.0 s from the beginning of time period T1 then the number of successful tests is increased by one. And if the SS receive a CELL UPDATE message from the UE, the SS shall transmit a CELL UPDATE CONFIRM message.
- 8) After 15 s from the beginning of time period T1, the parameters are changed to that as described for T2.
- 9) Repeat step 5) to 8) [TBD] times.

NOTE: The time required for receiving all the relevant system information data according to the reception procedure and the RRC procedure delay of system information blocks defined in 25.331 for a UTRAN cell. Since the maximum repetition period of the relevant system info blocks that needs to be received by the UE to camp on a cell is 1280ms and the maximum RRC procedure delay for reception system information block is 100ms, 1380 ms is assumed in this test case. Therefore the cell re-selection delay shall be less than 2.0 s.(Minimum requirement + 100ms).

8.3.5.2.5 Test requirements

For the test to pass, the total number of successful attempts shall be more than 90% with a confidence level of [FFS]% of the cases.

Table 8.3.5.2.5: Cell specific test requirements for Cell re-selection in CELL_FACH state, two freqs. in neighbour list

Parameter	Unit	Cell 1		Cell 2		Cell 3		Cell 4		Cell 5		Cell 6	
		T1	T2	T1	T2	T1	T2	T1	T2	T1	T2	T1	T2

UTRA RF Channel Number		Channel 1		Channel 2		Channel 1		Channel 1		Channel 2		Channel 2	
CPICH_Ec/Ior	dB	-9.9	-9.7	-9.7	-9.9	-9.9	-9.9	-9.9	-9.9	-9.9	-9.9	-9.9	-9.9
PCCPCH_Ec/Ior	dB	-12		-12		-12		-12		-12		-12	
SCH_Ec/Ior	dB	-11.9	-11.7	-11.7	-11.9	-11.9		-11.9		-11.9		-11.9	
PICH_Ec/Ior	dB	-15		-15		-15		-15		-15		-15	
S-CCPCH_Ec/Ior	dB	-12		-12		-12		-12		-12		-12	
OCNS_Ec/Ior	dB	1.282	1.309	-1.309	1.282	-1.295		-1.295		-1.295		-1.295	
\hat{I}_{or}/I_{oc}	dB	-2.1	2.9	2.9	-2.1	-9.4	-7	-9.4	-7	-7	-9.4	-7	-9.4
I_{oc}	dBm/3.8 4 MHz	-70											
CPICH_Ec/Io	dB	-14.7	-12.1	-12.1	-14.7	-22	-22.2	-22	-22.2	-22.2	-22	-22.2	-22
Propagation Condition		AWGN											
Cell_selection_and_reselection_quality_measure		CPICH E _c /N ₀		CPICH E _c /N ₀		CPICH E _c /N ₀		CPICH E _c /N ₀		CPICH E _c /N ₀		CPICH E _c /N ₀	
Qqualmin	dB	-20		-20		-20		-20		-20		-20	
Qrxlevmin	dBm	-115		-115		-115		-115		-115		-115	
UE_TXPWR_MAX_RACH	dBm	21		21		21		21		21		21	
Qoffset2 _{s,n}	dB	C1, C2: 0 C1, C3: 0 C1, C4: 0 C1, C5: 0 C1, C6: 0		C2, C1: 0 C2, C3: 0 C2, C4: 0 C2, C5: 0 C2, C6: 0		C3, C1: 0 C3, C2: 0 C3, C4: 0 C3, C5: 0 C3, C6: 0		C4, C1: 0 C4, C2: 0 C4, C3: 0 C4, C5: 0 C4, C6: 0		C5, C1: 0 C5, C2: 0 C5, C3: 0 C5, C4: 0 C5, C6: 0		C6, C1: 0 C6, C2: 0 C6, C3: 0 C6, C4: 0 C6, C5: 0	
Qhyst2	dB	0		0		0		0		0		0	
Treselection	s	0		0		0		0		0		0	
Sintrasearch	dB	not sent		not sent		not sent		not sent		not sent		not sent	
Sintersearch	dB	not sent		not sent		not sent		not sent		not sent		not sent	
IE "FACH Measurement occasion info"		sent		sent		sent		sent		Sent		sent	
FACH Measurement occasion cycle length coefficient		3		3		3		3		3		3	
Inter-frequency FDD measurement indicator		TRUE		TRUE		TRUE		TRUE		TRUE		TRUE	
Inter-frequency TDD measurement indicator		FALSE		FALSE		FALSE		FALSE		FALSE		FALSE	

Note: If the above Test Requirement differs from the Minimum Requirement then the Test Tolerance applied for this test is non-zero. The Test Tolerance for this test is defined in clause F.2 and the explanation of how the Minimum Requirement has been relaxed by the Test Tolerance is given in clause F.4.

8.3.5.3 Cell Reselection to GSM

Void.

8.3.6 Cell Re-selection in CELL_PCH

8.3.6.1 One frequency present in the neighbour list

8.3.6.1.1 Definition and applicability

The cell re-selection delay is defined as the time from a change of cell levels to the moment when this change makes the UE camp on a new cell, and starts to send preambles on the PRACH for the CELL UPDATE message with cause value "cell reselection" in the new cell.

The requirements and this test apply to the FDD UE.

8.3.6.1.2 Minimum requirements

The cell re-selection delay shall be less than 8 s with a DRX cycle length of 1.28 s.

The rate of correct cell reselections observed during repeated tests shall be at least 90% with a confidence level of [FFS]%.

NOTE: The cell re-selection delay can be expressed as: $T_{\text{evaluateFDD}} + T_{\text{SI}}$, where:

$T_{\text{evaluateFDD}}$	See table 4.1 in TS 25.133 [2] clause 4.2.2.
T_{SI}	Maximum repetition period of relevant system info blocks that needs to be received by the UE to camp on a cell. 1280 ms is assumed in this test case.

This gives a total of 7.68 s, allow 8s in the test case.

The normative reference for this requirement is TS 25.133 [2] clauses 5.6.2 and A.5.6.1.

8.3.6.1.3 Test purpose

To verify that the UE meets the minimum requirements and is capable of camping on to a new cell, within the required time, when the preferred cell conditions change.

8.3.6.1.4 Method of test

8.3.6.1.4.1 Initial conditions

Test environment: normal; see clauses G.2.1 and G.2.2.

Frequencies to be tested: mid range; see clause G.2.4.

This scenario implies the presence of 1 carrier and 6 cells as given in tables 8.3.6.1.1 and 8.3.6.1.2. The UE is requested to monitor neighbouring cells on 1 carrier. The maximum repetition period of the relevant system info blocks that needs to be received by the UE to camp on a cell shall be 1280 ms.

Table 8.3.6.1.1: General test parameters for Cell Re-selection in CELL_PCH, one freq. in neighbour list

Parameter		Unit	Value	Comment
initial condition	Active cell		Cell2	
	Neighbour cells		Cell1, Cell3, Cell4, Cell5, Cell6	
final condition	Active cell		Cell1	
Access Service Class (ASC#0) - Persistence value		-	1	Selected so that no additional delay is caused by the random access procedure. The value shall be used for all cells in the test.
HCS				Not used
DRX cycle length		s	1.28	The value shall be used for all cells in the test.
T1		s	15	T1 need to be defined so that cell re-selection reaction time is taken into account.
T2		s	15	T2 need to be defined so that cell re-selection reaction time is taken into account.

Table 8.3.6.1.2: Cell specific test parameters for Cell re-selection in CELL_PCH state, one freq. in neighbour list

Parameter	Unit	Cell 1		Cell 2		Cell 3		Cell 4		Cell 5		Cell 6	
		T1	T2	T1	T2	T1	T2	T1	T2	T1	T2	T1	T2
UTRA RF Channel Number		Channel 1		Channel 1		Channel 1		Channel 1		Channel 1		Channel 1	
CPICH_Ec/Ior	dB	-10		-10		-10		-10		-10		-10	
PCCPCH_Ec/Ior	dB	-12		-12		-12		-12		-12		-12	
SCH_Ec/Ior	dB	-12		-12		-12		-12		-12		-12	
PICH_Ec/Ior	dB	-15		-15		-15		-15		-15		-15	
OCNS_Ec/Ior	dB	-0.941		-0.941		-0.941		-0.941		-0.941		-0.941	
\hat{I}_{or}/I_{oc}	dB	7.3	10.27	10.27	7.3	0.27		0.27		0.27		0.27	
I_{oc}	dBm/ 3.84MHz	-70											
CPICH_Ec/Io	dB	-16	-13	-13	-16	-23		-23		-23		-23	
Propagation Condition		AWGN											
Cell_selection_and_reselection_quality_measure		CPICH E _c /N ₀		CPICH E _c /N ₀		CPICH E _c /N ₀		CPICH E _c /N ₀		CPICH E _c /N ₀		CPICH E _c /N ₀	
Qqualmin	dB	-20		-20		-20		-20		-20		-20	
Qrxlevmin	dBm	-115		-115		-115		-115		-115		-115	
UE_TXPWR_MAX_RACH	dBm	21		21		21		21		21		21	
Qoffset2 _{s, n}	dB	C1, C2: 0 C1, C3: 0 C1, C4: 0 C1, C5: 0 C1, C6: 0	C2, C1: 0 C2, C3: 0 C2, C4: 0 C2, C5: 0 C2, C6: 0	C3, C1: 0 C3, C2: 0 C3, C4: 0 C3, C5: 0 C3, C6: 0	C4, C1: 0 C4, C2: 0 C4, C3: 0 C4, C5: 0 C4, C6: 0	C5, C1: 0 C5, C2: 0 C5, C3: 0 C5, C4: 0 C5, C6: 0	C6, C1: 0 C6, C2: 0 C6, C3: 0 C6, C4: 0 C6, C5: 0						
Qhyst2	dB	0		0		0		0		0		0	
Treselection	s	0		0		0		0		0		0	
Sintrasearch	dB	not sent		not sent		not sent		not sent		not sent		not sent	

8.3.6.1.4.2 Procedure

- 1) The SS activates cell 1-6 with T1 defined parameters in table 8.3.6.1.2 and monitors cell 1 and 2 for random access requests from the UE.
- 2) The UE is switched on.
- 3) An RRC connection is set up according to the generic set-up procedure specified in TS 34.108 [3] subclause 7.3.3 to place the UE in the CELL_PCH state on Cell 2 and then the SS waits for this process to complete.
- 4) After 15 s from the completion of step 3 or the beginning of T1, the parameters are changed to those defined for T2 in table 8.3.6.1.2.
- 5) If the UE responds on Cell 1 with a PRACH (CELL UPDATE message cause "cell reselection") within 8s, then a success is recorded, the SS shall transmit a CELL UPDATE CONFIRM message and then the procedure moves to step 7.
- 6) Since the UE has failed to respond with the correct message within the allowed time, a failure is recorded. The SS shall then wait for a total of 15s from the beginning of T2 and if no response is received, the UE shall be switched off and the procedure returns to step 1. Otherwise the SS shall transmit a CELL UPDATE CONFIRM message and then the procedure continues with step 7.
- 7) After a total of 15 s from the beginning of T2, the parameters are changed to those defined for T1 in table 8.3.6.1.2.
- 8) If the UE responds on Cell 2 with a PRACH (CELL UPDATE message cause "cell reselection") within 8s, then a success is recorded and the procedure moves to step 10.
- 9) Since the UE has failed to respond with the correct message within the allowed time, a failure is recorded. The SS shall then wait for a total of 15s from the beginning of T1 and if no response is received the UE shall be

switched off and the procedure returns to step 1. Otherwise the SS shall transmit a CELL UPDATE CONFIRM message and then the procedure continues with step 10.

10) Steps 4 to 10 are repeated until a total of [50] successes and failures have been recorded.

NOTE: The time required for receiving all the relevant system information data according to the reception procedure and the RRC procedure delay of system information blocks defined in 25.331 for a UTRAN cell. Since the maximum repetition period of the relevant system info blocks that needs to be received by the UE to camp on a cell is 1280ms and the maximum RRC procedure delay for reception system information block is 100ms, 1380 ms is assumed in this test case. Therefore this gives a total of 7.78s (Minimum requirement + 100ms), allow 8s in the test case.

Specific Message Contents

All messages indicated above shall use the same content as described in the default message content in clause 9 of 34.108 [3], with the following exceptions:

RADIO BEARER SETUP (Step 3)

Information Element	Value/remark
RRC State Indicator	CELL PCH
UTRAN DRX cycle length coefficient	7
Downlink information for each radio link - Primary CPICH info - Primary scrambling code	100

8.3.6.1.5 Test requirements

For the test to pass, the total number of successful attempts shall be more than 90% with a confidence level of [FFS]% of the cases.

NOTE: If the above Test Requirement differs from the Minimum Requirement then the Test Tolerance applied for this test is non-zero. The Test Tolerance for this test is defined in clause F.2 and the explanation of how the Minimum Requirement has been relaxed by the Test Tolerance is given in clause F.4.

8.3.6.2 Two frequencies present in the neighbour list

8.3.6.2.1 Definition and applicability

The cell re-selection delay is defined as the time from a change of cell levels to the moment when this change makes the UE camp on a new cell, and starts to send preambles on the PRACH for the CELL UPDATE message with cause value "cell reselection" in the new cell.

The requirements and this test apply to the FDD UE.

8.3.6.2.2 Minimum requirement

The cell re-selection delay shall be less than 8 s with a DRX cycle length of 1.28 s.

The rate of correct cell reselections observed during repeated tests shall be at least 90% with a confidence level of [FFS]%.

NOTE: The cell re-selection delay can be expressed as: $T_{\text{evaluateFDD}} + T_{\text{SI}}$, where:

$T_{\text{evaluateFDD}}$	See table 4.1 in TS 25.133 [2] clause 4.2.2.
T_{SI}	Maximum repetition period of relevant system info blocks that needs to be received by the UE to camp on a cell. 1280 ms is assumed in this test case.

This gives a total of 7.68 s, allow 8s in the test case.

The normative reference for this requirement is TS 25.133 [2] clauses 5.6.2 and A.5.6.2.

8.3.6.2.3 Test purpose

To verify that the UE meets the minimum requirement and is capable of camping on to a new cell, within the required time, when the preferred cell conditions change.

8.3.6.2.4 Method of test

8.3.6.2.4.1 Initial conditions

Test environment: normal; see clauses G.2.1 and G.2.2.

Frequencies to be tested: mid range; see clause G.2.4.

This scenario implies the presence of 2 carriers and 6 cells as given in tables 8.3.6.2.1 and 8.3.6.2.2. The UE is requested to monitor neighbouring cells on 2 carriers. The maximum repetition period of the relevant system info blocks that needs to be received by the UE to camp on a cell shall be 1 280 ms.

Table 8.3.6.2.1: General test parameters for Cell Re-selection in CELL_PCH, two freqs. in neighbour list

Parameter		Unit	Value	Comment
initial condition	Active cell		Cell2	
	Neighbour cells		Cell1, Cell3, Cell4, Cell5, Cell6	
final condition	Active cell		Cell1	
Access Service Class (ASC#0) - Persistence value		-	1	Selected so that no additional delay is caused by the random access procedure. The value shall be used for all cells in the test.
HCS				Not used
DRX cycle length		s	1.28	The value shall be used for all cells in the test.
T1		s	15	T1 need to be defined so that cell re-selection reaction time is taken into account.
T2		s	15	T2 need to be defined so that cell re-selection reaction time is taken into account.

Table 8.3.6.2.2: Cell specific test parameters for Cell re-selection in CELL_PCH state, two freqs. in neighbour list

Parameter	Unit	Cell 1		Cell 2		Cell 3		Cell 4		Cell 5		Cell 6	
		T1	T2	T1	T2	T1	T2	T1	T2	T1	T2	T1	T2
UTRA RF Channel Number		Channel 1		Channel 2		Channel 1		Channel 1		Channel 2		Channel 2	
CPICH_Ec/Ior	dB	-10		-10		-10		-10		-10		-10	
PCCPCH_Ec/Ior	dB	-12		-12		-12		-12		-12		-12	
SCH_Ec/Ior	dB	-12		-12		-12		-12		-12		-12	
PICH_Ec/Ior	dB	-15		-15		-15		-15		-15		-15	
OCNS_Ec/Ior	dB	-0.941		-0.941		-0.941		-0.941		-0.941		-0.941	
\hat{I}_{or}/I_{oc}	dB	-3.4	2.2	2.2	-3.4	-7.4	-4.8	-7.4	-4.8	-4.8	-7.4	-4.8	-7.4
I_{oc}	dBm/3.8 4 MHz	-70											
CPICH_Ec/Io	dB	-16	-13	-13	-16	-20		-20		-20		-20	
Propagation Condition		AWGN											
Cell_selection_and_reselection_quality_measure		CPICH E _c /N ₀		CPICH E _c /N ₀		CPICH E _c /N ₀		CPICH E _c /N ₀		CPICH E _c /N ₀		CPICH E _c /N ₀	
Qqualmin	dB	-20		-20		-20		-20		-20		-20	
Qrxlevmin	dBm	-115		-115		-115		-115		-115		-115	
UE_TXPWR_MAX_RACH	dBm	21		21		21		21		21		21	
Qoffset2 _{s, n}	dB	C1, C2: 0 C1, C3: 0 C1, C4: 0 C1, C5: 0 C1, C6: 0		C2, C1: 0 C2, C3: 0 C2, C4: 0 C2, C5: 0 C2, C6: 0		C3, C1: 0 C3, C2: 0 C3, C4: 0 C3, C5: 0 C3, C6: 0		C4, C1: 0 C4, C2: 0 C4, C3: 0 C4, C5: 0 C4, C6: 0		C5, C1: 0 C5, C2: 0 C5, C3: 0 C5, C4: 0 C5, C6: 0		C6, C1: 0 C6, C2: 0 C6, C3: 0 C6, C4: 0 C6, C5: 0	
Qhyst2	dB	0		0		0		0		0		0	
Treselection	s	0		0		0		0		0		0	
Sintrasearch	dB	not sent		not sent		not sent		not sent		not sent		not sent	
Sintersearch	dB	not sent		not sent		not sent		not sent		not sent		not sent	

8.3.6.2.4.2 Procedure

- 1) The SS activates cell 1-6 with T1 defined parameters in table 8.3.6.2.3 and monitors cell 1 and 2 for random access requests from the UE.
- 2) The UE is switched on.
- 3) A RRC connection is set up according the generic set-up procedure specified in TS 34.108 [3] subclause 7.3.3 to place the UE in CELL_PCH state on cell 2. The SS waits for this process to complete.
- 4) After 15 s from the completion of step 3 or the beginning of T1, the parameters are changed to those defined for T2.
- 5) If the UE responds on Cell 1 with a PRACH (CELL UPDATE message cause "cell reselection") within 8s, then a success is recorded, the SS shall transmit a CELL UPDATE CONFIRM message and then the procedure moves to step 7.
- 6) Since the UE has failed to respond with the correct message within the allowed time, a failure is recorded. The SS shall then wait for a total of 15s from the beginning of T2 and if no response is received the UE shall be switched off and the procedure returns to step 1. Otherwise the SS shall transmit a CELL UPDATE CONFIRM message and then the procedure continues with step 7.
- 7) After a total of 15 s from the beginning of T2, the parameters are changed to those defined for T1.
- 8) If the UE responds on Cell 2 with a PRACH (CELL UPDATE message cause "cell reselection") within 8s, then a success is recorded and the procedure moves to step 10.
- 9) Since the UE has failed to respond with the correct message within the allowed time, a failure is recorded. The SS shall then wait for a total of 15s from the beginning of T1 and if no response is received the UE shall be

switched off and the procedure returns to step 1. Otherwise the SS shall transmit a CELL UPDATE CONFIRM message and then the procedure continues with step 10.

10) Steps 4 to 10 are repeated until a total of [50] successes and failures have been recorded.

NOTE: The time required for receiving all the relevant system information data according to the reception procedure and the RRC procedure delay of system information blocks defined in 25.331 for a UTRAN cell. Since the maximum repetition period of the relevant system info blocks that needs to be received by the UE to camp on a cell is 1280ms and the maximum RRC procedure delay for reception system information block is 100ms, 1380 ms is assumed in this test case. Therefore this gives a total of 7.78s (Minimum requirement + 100ms), allow 8s in the test case.

Specific Message Contents

All messages indicated above shall use the same content as described in the default message content in clause 9 of 34.108 [3], with the following exceptions:

RADIO BEARER SETUP (Step 3)

Information Element	Value/remark
RRC State Indicator	CELL PCH
UTRAN DRX cycle length coefficient	7
Downlink information for each radio link - Primary CPICH info - Primary scrambling code	100

8.3.6.2.5 Test requirements

For the test to pass, the total number of successful tests shall be more than 90% with a confidence level of [FFS]% of the cases.

Table 8.3.6.2.3: Test parameters for Cell re-selection in CELL_PCH state, multi carrier multi cell, two freqs. in neighbour list

Parameter	Unit	Cell 1		Cell 2		Cell 3		Cell 4		Cell 5		Cell 6	
		T1	T2	T1	T2	T1	T2	T1	T2	T1	T2	T1	T2
UTRA RF Channel Number		Channel 1		Channel 2		Channel 1		Channel 1		Channel 2		Channel 2	
CPICH_Ec/Ior	dB	-9.9	-9.7	-9.7	-9.9	-9.9		-9.9		-9.9		-9.9	
PCCPCH_Ec/Ior	dB	-12		-12		-12		-12		-12		-12	
SCH_Ec/Ior	dB	-11.9	-11.7	-11.7	11.9	-11.9		-11.9		-11.9		-11.9	
PICH_Ec/Ior	dB	-15		-15		-15		-15		-15		-15	
OCNS_Ec/Ior	dB	-0.954	-0.982	-0.982	-0.954	-0.954		-0.954		-0.954		-0.954	
\hat{I}_{or}/I_{oc}	dB	-3.5	2.8	2.8	-3.5	-9.5	-7.7	-9.5	-7.7	-7.7	-9.5	-7.7	-9.5
I_{oc}	dBm / 3.84 MHz	-70											
CPICH_Ec/Io	dB	-15.6	-12	-12	-15.6	-21.6	-22.7	-21.6	-22.7	-22.7	-21.6	-22.7	-21.6
Propagation Condition		AWGN											
Cell_selection_and_reselection_quality_measure		CPICH E _c /N ₀		CPICH E _c /N ₀		CPICH E _c /N ₀		CPICH E _c /N ₀		CPICH E _c /N ₀		CPICH E _c /N ₀	
Qqualmin	dB	-20		-20		-20		-20		-20		-20	
Qrxlevmin	dBm	-115		-115		-115		-115		-115		-115	
UE_TXPWR_MAX_RACH	dB	21		21		21		21		21		21	
Qoffset2 _{s, n}	dB	C1, C2: 0 C1, C3: 0 C1, C4: 0 C1, C5: 0 C1, C6: 0	C2, C1: 0 C2, C3: 0 C2, C4: 0 C2, C5: 0 C2, C6: 0	C3, C1: 0 C3, C2: 0 C3, C4: 0 C3, C5: 0 C3, C6: 0	C4, C1: 0 C4, C2: 0 C4, C3: 0 C4, C5: 0 C4, C6: 0	C5, C1: 0 C5, C2: 0 C5, C3: 0 C5, C4: 0 C5, C6: 0	C6, C1: 0 C6, C2: 0 C6, C3: 0 C6, C4: 0 C6, C5: 0						
Qhyst2	dB	0		0		0		0		0		0	
Treselection	s	0		0		0		0		0		0	
Sintrasearch	dB	not sent		not sent		not sent		not sent		not sent		not sent	
Sintersearch	dB	not sent		not sent		not sent		not sent		not sent		not sent	

NOTE: If the above Test Requirement differs from the Minimum Requirement then the Test Tolerance applied for this test is non-zero. The Test Tolerance for this test is defined in clause F.2 and the explanation of how the Minimum Requirement has been relaxed by the Test Tolerance is given in clause F.4.

8.3.7 Cell Re-selection in URA_PCH

8.3.7.1 One frequency present in the neighbour list

8.3.7.1.1 Definition and applicability

The cell re-selection delay is defined as the time from a change of cell levels to the moment when this change makes the UE camp on a new cell, and starts to send preambles on the PRACH for the URA UPDATE message with cause value "URA reselection" in the new cell.

The requirements and this test apply to the FDD UE.

8.3.7.1.2 Minimum requirement

The cell re-selection delay shall be less than 8 s with a DRX cycle length of 1.28 s.

The rate of correct cell reselections observed during repeated tests shall be at least 90% with a confidence level of [FFS]%.

NOTE: The cell re-selection delay can be expressed as: $T_{\text{evaluateFDD}} + T_{\text{SI}}$, where:

$T_{\text{evaluateFDD}}$	See table 4.1 in TS 25.133 [2] clause 4.2.2.
T_{SI}	Maximum repetition period of relevant system info blocks that needs to be received by the UE to camp on a cell. 1280 ms is assumed in this test case.

This gives a total of 7.68 s, allow 8s in the test case.

The normative reference for this requirement is TS 25.133 [2] clauses 5.7.2 and A.5.7.1.

8.3.7.1.3 Test purpose

To verify that the UE meets the minimum requirement and is capable of camping on to a new cell, within the required time, when the preferred cell conditions change.

8.3.7.1.4 Method of test

8.3.7.1.4.1 Initial conditions

Test environment: normal; see clauses G.2.1 and G.2.2.

Frequencies to be tested: mid range; see clause G.2.4.

This scenario implies the presence of 1 carrier and 6 cells as given in tables 8.3.7.1.1 and 8.3.7.1.2. The UE is requested to monitor neighbouring cells on 1 carrier. The maximum repetition period of the relevant system info blocks that needs to be received by the UE to camp on a cell shall be 1 280 ms. In System Information Block Type 2 cell1 and cell 2 URA identity is set to a different value.

Table 8.3.7.1.1: General test parameters for Cell Re-selection in URA_PCH, one freq. in neighbour list

Parameter		Unit	Value	Comment
Initial condition	Active cell		Cell2	
	Neighbour cells		Cell1, Cell3, Cell4, Cell5, Cell6	
Final condition	Active cell		Cell1	
SYSTEM INFORMATION BLOCK TYPE 2 - URA identity list - URA identity		-	0000 0000 0000 0001(B) (Cell 1) 0000 0000 0000 0002(B) (Cell 2)	
Access Service Class (ASC#0) - Persistence value		-	1	Selected so that no additional delay is caused by the random access procedure. The value shall be used for all cells in the test.
HCS				Not used
DRX cycle length		s	1,28	The value shall be used for all cells in the test.
T1		s	15	T1 need to be defined so that cell re-selection reaction time is taken into account.
T2		s	15	T2 need to be defined so that cell re-selection reaction time is taken into account.

Table 8.3.7.1.2: Cell specific test parameters for Cell re-selection in URA_PCH state, one freq. in neighbour list

Parameter	Unit	Cell 1		Cell 2		Cell 3		Cell 4		Cell 5		Cell 6	
		T1	T2	T1	T2	T1	T2	T1	T2	T1	T2	T1	T2
UTRA RF Channel Number		Channel 1		Channel 1		Channel 1		Channel 1		Channel 1		Channel 1	
CPICH_Ec/lor	dB	-10		-10		-10		-10		-10		-10	
PCCPCH_Ec/lor	dB	-12		-12		-12		-12		-12		-12	
SCH_Ec/lor	dB	-12		-12		-12		-12		-12		-12	
PICH_Ec/lor	dB	-15		-15		-15		-15		-15		-15	
OCNS_Ec/lor	dB	-0,941		-0,941		-0,941		-0,941		-0,941		-0,941	
\hat{I}_{or}/I_{oc}	dB	7,3	10,27	10,27	7,3	0,27		0,27		0,27		0,27	
I_{oc}	dBm / 3,84 MHz	-70											
CPICH_Ec/lo	dB	-16	-13	-13	-16	-23		-23		-23		-23	
Propagation Condition		AWGN											
Cell_selection_and_reselection_quality_measure		CPICH E _c /N ₀		CPICH E _c /N ₀		CPICH E _c /N ₀		CPICH E _c /N ₀		CPICH E _c /N ₀		CPICH E _c /N ₀	
Qqualmin	dB	-20		-20		-20		-20		-20		-20	
Qrxlevmin	dBm	-115		-115		-115		-115		-115		-115	
UE_TXPWR_MAX_RACH	dB	21		21		21		21		21		21	
Qoffset2 _{s, n}	dB	C1, C2: 0 C1, C3: 0 C1, C4: 0 C1, C5: 0 C1, C6: 0	C2, C1: 0 C2, C3: 0 C2, C4: 0 C2, C5: 0 C2, C6: 0	C3, C1: 0 C3, C2: 0 C3, C4: 0 C3, C5: 0 C3, C6: 0	C4, C1: 0 C4, C2: 0 C4, C3: 0 C4, C5: 0 C4, C6: 0	C5, C1: 0 C5, C2: 0 C5, C3: 0 C5, C4: 0 C5, C6: 0	C6, C1: 0 C6, C2: 0 C6, C3: 0 C6, C4: 0 C6, C5: 0						
Qhyst2	dB	0		0		0		0		0		0	
Treselection	S	0		0		0		0		0		0	
Sintrasearch	dB	not sent		not sent		not sent		not sent		not sent		not sent	

8.3.7.1.4.2 Procedure

- 1) The SS activates cell 1-6 with T1 defined parameters in table 8.3.7.1.2 and monitors cell 1 and 2 for random access requests from the UE.
- 2) The UE is switched on.
- 3) An RRC connection is set up according to the generic set-up procedure specified in TS 34.108 [3] subclause 7.3.3 to place the UE in the URA_PCH state on Cell 2 and then the SS waits for this process to complete.
- 4) After 15 s from the completion of step 3 or the beginning of T1, the parameters are changed to those defined for T2 in table 8.3.7.1.2.
- 5) If the UE responds on Cell 1 with a PRACH (URA UPDATE message cause "URA reselection") within 8s, then a success is recorded, the SS shall transmit a URA UPDATE CONFIRM message and then the procedure moves to step 7.
- 6) Since the UE has failed to respond with the correct message within the allowed time, a failure is recorded. The SS shall then wait for a total of 15s from the beginning of T2 and if no response is received, the UE shall be switched off and the procedure returns to step 1. Otherwise the SS shall transmit a URA UPDATE CONFIRM message and then the procedure continues with step 7.
- 7) After a total of another 15 s from the beginning of T2, the parameters are changed to those defined for T1 in table 8.3.7.1.2.
- 8) If the UE responds on Cell 2 with a PRACH (URA UPDATE message cause "URA reselection") within 8s, then a success is recorded and the procedure moves to step 10.
- 9) Since the UE has failed to respond with the correct message within the allowed time, a failure is recorded. The SS shall then wait for a total of 15s from the beginning of T1 and if no response is received the UE shall be

switched off and the procedure returns to step 1. Otherwise the SS shall transmit a URA UPDATE CONFIRM message and then the procedure continues with step 10.

10) Steps 4 to 10 are repeated until a total of [TBD] successes and failures have been recorded.

NOTE: The time required for receiving all the relevant system information data according to the reception procedure and the RRC procedure delay of system information blocks defined in 25.331 for a UTRAN cell. Since the maximum repetition period of the relevant system info blocks that needs to be received by the UE to camp on a cell is 1280ms and the maximum RRC procedure delay for reception system information block is 100ms, 1380 ms is assumed in this test case. Therefore this gives a total of 7.78s (Minimum requirement + 100ms), allow 8s in the test case.

Specific Message Contents

All messages indicated above shall use the same content as described in the default message content in clause 9 of 34.108 [3], with the following exceptions:

RADIO BEARER SETUP (Step 3)

Information Element	Value/remark
RRC State Indicator	URA PCH
UTRAN DRX cycle length coefficient	7
Downlink information for each radio link - Primary CPICH info - Primary scrambling code	100

8.3.7.1.5 Test requirements

For the test to pass, the total number of successful attempts shall be more than 90% with a confidence level of [FFS]% of the cases.

NOTE: If the above Test Requirement differs from the Minimum Requirement then the Test Tolerance applied for this test is non-zero. The Test Tolerance for this test is defined in clause F.2 and the explanation of how the Minimum Requirement has been relaxed by the Test Tolerance is given in clause F.4.

8.3.7.2 Two frequencies present in the neighbour list

8.3.7.2.1 Definition and applicability

The cell re-selection delay is defined as the time from a change of cell levels to the moment when this change makes the UE camp on a new cell, and starts to send preambles on the PRACH for the URA UPDATE message with cause value "URA reselection" in the new cell.

The requirements and this test apply to the FDD UE.

8.3.7.2.2 Minimum requirement

The cell re-selection delay shall be less than 8 s with a DRX cycle length of 1.28 s.

The rate of correct cell reselections observed during repeated tests shall be at least 90% with a confidence level of [FFS]%.

NOTE: The cell re-selection delay can be expressed as: $T_{\text{evaluateFDD}} + T_{\text{SI}}$, where:

$T_{\text{evaluateFDD}}$	See table 4.1 in TS 25.133 [2] clause 4.2.2.
T_{SI}	Maximum repetition period of relevant system info blocks that needs to be received by the UE to camp on a cell. 1280 ms is assumed in this test case.

This gives a total of 7.68 s, allow 8s in the test case.

The normative reference for this requirement is TS 25.133 [2] clauses 5.7.2 and A.5.7.2.

8.3.7.2.3 Test purpose

To verify that the UE meets the minimum requirement and is capable of camping on to a new cell, within the required time, when the preferred cell conditions change.

8.3.7.2.4 Method of test

8.3.7.2.4.1 Initial conditions

Test environment: normal; see clauses G.2.1 and G.2.2.

Frequencies to be tested: mid range; see clause G.2.4.

This scenario implies the presence of 2 carriers and 6 cells as given in tables 8.3.7.2.1 and 8.3.7.2.2. The UE is requested to monitor neighbouring cells on 2 carriers. The maximum repetition period of the relevant system info blocks that needs to be received by the UE to camp on a cell shall be 1 280 ms. In System Information Block Type 2 in cell 1 and cell 2 URA identity is set to different value.

Table 8.3.7.2.1: General test parameters for Cell Re-selection in URA_PCH, two freqs. in neighbour list

Parameter		Unit	Value	Comment
Initial condition	Active cell		Cell2	
	Neighbour cells		Cell1, Cell3, Cell4, Cell5, Cell6	
Initial condition	Active cell Cell2		Cell1	
SYSTEM INFORMATION BLOCK TYPE 2 - URA identity list - URA identity		-	0000 0000 0000 0001(B) (Cell 1) 0000 0000 0000 0002(B) (Cell 2)	
Access Service Class (ASC#0) - Persistence value		-	1	Selected so that no additional delay is caused by the random access procedure. The value shall be used for all cells in the test.
HCS				Not used
DRX cycle length		s	1,28	The value shall be used for all cells in the test.
T1		s	15	T1 need to be defined so that cell re-selection reaction time is taken into account.
T2		s	15	T2 need to be defined so that cell re-selection reaction time is taken into account.

Table 8.3.7.2.2: Cell specific test parameters for Cell Re-selection in URA_PCH state, two freqs. in neighbour list

Parameter	Unit	Cell 1		Cell 2		Cell 3		Cell 4		Cell 5		Cell 6	
		T1	T2	T1	T2	T1	T2	T1	T2	T1	T2	T1	T2
UTRA RF Channel Number		Channel 1		Channel 2		Channel 1		Channel 1		Channel 2		Channel 2	
CPICH_Ec/Ior	dB	-10		-10		-10		-10		-10		-10	
PCCPCH_Ec/Ior	dB	-12		-12		-12		-12		-12		-12	
SCH_Ec/Ior	dB	-12		-12		-12		-12		-12		-12	
PICH_Ec/Ior	dB	-15		-15		-15		-15		-15		-15	
OCNS_Ec/Ior	dB	-0.941		-0.941		-0.941		-0.941		-0.941		-0.941	
\hat{I}_{or}/I_{oc}	dB	-3.4	2.2	2.2	-3.4	-7.4	-4.8	-7.4	-4.8	-4.8	-7.4	-4.8	-7.4
I_{oc}	dBm / 3.84 MHz	-70											
CPICH_Ec/Io	dB	-16	-13	-13	-16	-20		-20		-20		-20	
Propagation Condition		AWGN											
Cell_selection_and_reselection_quality_measure		CPICH E _c /N ₀		CPICH E _c /N ₀		CPICH E _c /N ₀		CPICH E _c /N ₀		CPICH E _c /N ₀		CPICH E _c /N ₀	
Qqualmin	dB	-20		-20		-20		-20		-20		-20	
Qrxlevmin	dBm	-115		-115		-115		-115		-115		-115	
UE_TXPWR_MAX_RACH	dB	21		21		21		21		21		21	
Qoffset2 _{s, n}	dB	C1, C2: 0 C1, C3: 0 C1, C4: 0 C1, C5: 0 C1, C6: 0		C2, C1: 0 C2, C3: 0 C2, C4: 0 C2, C5: 0 C2, C6: 0		C3, C1: 0 C3, C2: 0 C3, C4: 0 C3, C5: 0 C3, C6: 0		C4, C1: 0 C4, C2: 0 C4, C3: 0 C4, C5: 0 C4, C6: 0		C5, C1: 0 C5, C2: 0 C5, C3: 0 C5, C4: 0 C5, C6: 0		C6, C1: 0 C6, C2: 0 C6, C3: 0 C6, C4: 0 C6, C5: 0	
Qhyst2	dB	0		0		0		0		0		0	
Treselection	s	0		0		0		0		0		0	
Sintrasearch	dB	not sent		not sent		not sent		not sent		not sent		not sent	
Sintersearch	dB	not sent		not sent		not sent		not sent		not sent		not sent	

8.3.7.2.4.2 Procedures

- 1) The SS activates cell 1-6 with T1 defined parameters in table 8.3.7.2.3 and monitors cell 1 and 2 for random access requests from the UE.
- 2) The UE is switched on.
- 3) An RRC connection is set up according the generic set-up procedure specified in TS 34.108 [3] subclause 7.3.3 to place the UE in URA_PCH state on cell 2. The SS waits for this process to complete.
- 4) After 15 s from the completion of step 3 or the beginning of T1, the parameters are changed to those defined for T2 in table 8.3.7.2.3.
- 5) If the UE responds on Cell 1 with a PRACH (URA UPDATE message cause "URA reselection") within 8s, then a success is recorded, the SS shall transmit a URA UPDATE CONFIRM message and then the procedure moves to step 7.
- 6) Since the UE has failed to respond with the correct message within the allowed time, a failure is recorded. The SS shall then wait for a total of 15s from the beginning of T2 and if no response is received the UE shall be switched off and the procedure returns to step 1. Otherwise the SS shall transmit a URA UPDATE CONFIRM message and then the procedure continues with step 7.
- 7) After a total of 15 s from the beginning of T2, the parameters are changed to those defined for T1 in table 8.3.7.2.3.
- 8) If the UE responds on Cell 2 with a PRACH (URA UPDATE message cause "URA reselection") within 8s, then a success is recorded and the procedure moves to step 10.

9) Since the UE has failed to respond with the correct message within the allowed time, a failure is recorded. The SS shall then wait for a total of 15s from the beginning of T1 and if no response is received the UE shall be switched off and the procedure returns to step 1. Otherwise the SS shall transmit a URA UPDATE CONFIRM message and then the procedure continues with step 10.

10) Steps 4 to 10 are repeated until a total of [TBD] successes and failures have been recorded.

NOTE: The time required for receiving all the relevant system information data according to the reception procedure and the RRC procedure delay of system information blocks defined in 25.331 for a UTRAN cell. Since the maximum repetition period of the relevant system info blocks that needs to be received by the UE to camp on a cell is 1280ms and the maximum RRC procedure delay for reception system information block is 100ms, 1380 ms is assumed in this test case. Therefore this gives a total of 7.78s (Minimum requirement + 100ms), allow 8s in the test case.

Specific Message Contents

All messages indicated above shall use the same content as described in the default message content in clause 9 of 34.108 [3], with the following exceptions:

RADIO BEARER SETUP (Step 3)

Information Element	Value/remark
RRC State Indicator	URA PCH
UTRAN DRX cycle length coefficient	7
Downlink information for each radio link - Primary CPICH info - Primary scrambling code	100

8.3.7.2.5 Test requirements

For the test to pass, the total number of successful tests shall be more than 90% with a confidence level of [FFS]% of the cases.

Table 8.3.7.2.3: Test parameters for Cell re-selection in URA_PCH state, multi carrier multi cell, two freqs. in neighbour list

Parameter	Unit	Cell 1		Cell 2		Cell 3		Cell 4		Cell 5		Cell 6	
		T1	T2	T1	T2	T1	T2	T1	T2	T1	T2	T1	T2
UTRA RF Channel Number		Channel 1		Channel 2		Channel 1		Channel 1		Channel 2		Channel 2	
CPICH_Ec/Ior	dB	-9.9	-9.7	-9.7	-9.9	-9.9		-9.9		-9.9		-9.9	
PCCPCH_Ec/Ior	dB	-12		-12		-12		-12		-12		-12	
SCH_Ec/Ior	dB	-11.9	-11.7	-11.7	-11.9	-11.9		-11.9		-11.9		-11.9	
PICH_Ec/Ior	dB	-15		-15		-15		-15		-15		-15	
OCNS_Ec/Ior	dB	-0.954	-0.982	-0.982	-0.954	-0.954		-0.954		-0.954		-0.954	
\hat{I}_{or}/I_{oc}	dB	-3.5	2.8	2.8	-3.5	-9.5	-7.7	-9.5	-7.7	-7.7	-9.5	-7.7	-9.5
I_{oc}	dBm / 3.84 MHz	70											
CPICH_Ec/Io	dB	-15.6	-12	-12	-15.6	-21.6	-22.7	-21.6	-22.7	-22.7	-21.6	-22.7	-21.6
Propagation Condition		AWGN											
Cell_selection_and_reselection_quality_measure		CPICH E _c /N ₀		CPICH E _c /N ₀		CPICH E _c /N ₀		CPICH E _c /N ₀		CPICH E _c /N ₀		CPICH E _c /N ₀	
Qqualmin	dB	-20		-20		-20		-20		-20		-20	
Qrxlevmin	dBm	-115		-115		-115		-115		-115		-115	
UE_TXPWR_MAX_RACH	dB	21		21		21		21		21		21	
Qoffset2 _{s, n}	dB	C1, C2: 0 C1, C3: 0 C1, C4: 0 C1, C5: 0 C1, C6: 0	C2, C1: 0 C2, C3: 0 C2, C4: 0 C2, C5: 0 C2, C6: 0	C3, C1: 0 C3, C2: 0 C3, C4: 0 C3, C5: 0 C3, C6: 0	C4, C1: 0 C4, C2: 0 C4, C3: 0 C4, C5: 0 C4, C6: 0	C5, C1: 0 C5, C2: 0 C5, C3: 0 C5, C4: 0 C5, C6: 0	C6, C1: 0 C6, C2: 0 C6, C3: 0 C6, C4: 0 C6, C5: 0						
Qhyst2	dB	0		0		0		0		0		0	
Treselection	s	0		0		0		0		0		0	
Sintrasearch	dB	not sent		not sent		not sent		not sent		not sent		not sent	
Sintersearch	dB	not sent		not sent		not sent		not sent		not sent		not sent	

NOTE: If the above Test Requirement differs from the Minimum Requirement then the Test Tolerance applied for this test is non-zero. The Test Tolerance for this test is defined in clause F.2 and the explanation of how the Minimum Requirement has been relaxed by the Test Tolerance is given in clause F.4.

8.4 RRC Connection Control

8.4.1 RRC Re-establishment delay

8.4.1.1 Test 1

8.4.1.1.1 Definition and applicability

The UE Re-establishment delay requirement ($T_{UE-RE-ESTABLISH-REQ}$) is defined as the time between the moment when radio link failure is considered by the UE, to when the UE starts to send preambles on the PRACH.

$T_{UE-RE-ESTABLISH-REQ}$ is depending on whether the target cell is known by the UE or not. A cell is known if either or both of the following conditions are true:

- the UE has had radio links connected to the cell in the previous (old) active set.
- the cell has been measured by the UE during the last 5 seconds.

The phase reference is the primary CPICH.

The requirements of this test apply to the FDD UE.

8.4.1.1.2 Minimum requirement

The Re-establishment delay $T_{RE-ESTABLISH}$ to a known cell shall be less than 1.9 s.

The rate of correct RRC re-establishments observed during repeated tests shall be at least 90%.

NOTE: The Re-establishment delay in this case can be expressed as

$$T_{RE-ESTABLISH} = T_{RRC-RE-ESTABLISH} + T_{UE-RE-ESTABLISH-REQ-KNOWN}$$

where

$$T_{RRC-RE-ESTABLISH} = 160\text{ms} + (N_{313} - 1) * 10\text{ms} + T_{313}$$

$$T_{UE-RE-ESTABLISH-REQ-KNOWN} = 50\text{ms} + T_{\text{search}} + T_{SI} + T_{RA}$$

$$N_{313} = 20$$

$$T_{313} = 0\text{s}$$

$$T_{\text{search}} = 100\text{ms}$$

$$T_{RA} = \text{The additional delay caused by the random access procedure. 40 ms is assumed in this test case.}$$

$$T_{SI} \text{ is the time required for receiving all the relevant system information data according to the reception procedure and the RRC procedure delay of system information blocks defined in 25.331 for a UTRAN cell (ms). 1280 ms is assumed in this test case.}$$

This gives a total of 1820ms, allow 1.9s in the test case.

8.4.1.1.3 Test purpose

To verify that the UE meets the minimum requirement.

8.4.1.1.4 Method of test

8.4.1.1.4.1 Initial conditions

Test environment: normal; see clauses G.2.1 and G.2.2.

Frequencies to be tested: mid range; see clause G.2.4.

The test parameters are given in table 8.4.1.1 and table 8.4.1.2 below. The maximum repetition period of the relevant system info blocks that needs to be received by the UE to camp on a cell shall be 1280 ms. And DRX cycle length shall be 1280ms. In the measurement control information it is indicated to the UE that periodic reporting shall be used. The test consist of 2 successive time periods, with a time duration of T1 and T2 respectively. At the start of time period T2, the dedicated channel is removed.

Table 8.4.1.1 General test parameters for RRC re-establishment delay, Test 1

Parameter	Unit	Value	Comment
DCH Parameters		DL and UL Reference measurement channel 12.2 kbps	As specified in clause C.3.1 and C.2.1
Power Control		On	
Active cell, Initial condition		Cell 1	
Active cell, Final condition		Cell 2	
N313		20	
N315		1	
T313	Seconds	0	
Monitored cell list size		24	Monitored set shall only include intra frequency neighbours.
Cell 2			Included in the monitored set
Reporting frequency	Seconds	4	
T1	s	10	
T2	s	6	

Table 8.4.1.2 Cell specific parameters for RRC re-establishment delay test, Test 1

Parameter	Unit	Cell 1		Cell 2	
		T1	T2	T1	T2
Cell Frequency	ChNr	1		1	
CPICH_Ec/Ior	dB	-10		-10	
PCCPCH_Ec/Ior	dB	-12		-12	
SCH_Ec/Ior	dB	-12		-12	
PICH_Ec/Ior	dB	-15		-15	
DCH_Ec/Ior	dB	-17	-Infinity	Not applicable	
OCNS_Ec/Ior	dB	-1.049	-0.941	-0.941	
\hat{I}_{or}/I_{oc}	dB	2,39	-Infinity	4,39	
I_{oc}	dBm/ 3.84 MHz	-70			
CPICH_Ec/Io	dB	-15	-Infinity	-13	
Propagation Condition		AWGN			

8.4.1.1.4.2 Procedure

- 1) The RF parameters are set up according to T1.
- 2) The UE is switched on.
- 3) A call is set up according to the test procedure specified in TS 34.108 [3] subclause 7.3.4 without Compressed mode parameters.

[Editor's note: subclause 7.3.4 in TS 34.108 (Message sequence chart for Handover Test procedure) is not yet specified.

- 4) The SS waits for random access requests from the UE on cell 2.
- 5) 10 s after step3 has completed, the parameters are changed to that as described for T2.
- 6) If the UE responds on cell 2 within 2.0 s from the beginning of time period T2 with a CELL_UPDATE command then the number of successful tests is increased by one.
- 7) SS shall transmit a RRC CONNECTION RELEASE message to make the UE transit to idle mode.
- 8) After 6 seconds from the beginning of time period T2, the RF parameters are set up according to T1.
- 9) The SS shall wait for 30s to make the UE complete cell reselection to cell1.
- 10) Repeat step 3-9 [TBD] times.

NOTE: The time required for receiving all the relevant system information data according to the reception procedure and the RRC procedure delay of system information blocks defined in 25.331 for a UTRAN cell. Since the maximum repetition period of the relevant system info blocks that needs to be received by the UE to camp on a cell is 1280ms and the maximum RRC procedure delay for reception system information block is 100ms, 1380 ms is assumed in this test case. Therefore this gives a total of 1920ms (Minimum requirement + 100ms), allow 2s in the test case.

8.4.1.1.5 Test requirements

For the test to pass, the total number of successful tests shall be more than 90% with a confidence level of [FFS]% of the cases.

Note: If the above Test Requirement differs from the Minimum Requirement then the Test Tolerance applied for this test is non-zero. The Test Tolerance for this test is defined in clause F.2 and the explanation of how the Minimum Requirement has been relaxed by the Test Tolerance is given in clause F.4.

8.4.1.2 Test 2

8.4.1.2.1 Definition and applicability

The UE Re-establishment delay requirement ($T_{UE-RE-ESTABLISH-REQ}$) is defined as the time between the moment when radio link failure is considered by the UE, to when the UE starts to send preambles on the PRACH.

$T_{UE-RE-ESTABLISH-REQ}$ is depending on whether the target cell is known by the UE or not. A cell is known if either or both of the following conditions are true:

- the UE has had radio links connected to the cell in the previous (old) active set.
- the cell has been measured by the UE during the last 5 seconds.

The phase reference is the primary CPICH.

The requirements of this test apply to the FDD UE.

8.4.1.2.2 Minimum requirement

The rate of correct RRC re-establishments observed during repeated tests shall be at least 90%.

NOTE: The Re-establishment delay in this case can be expressed as

$$T_{RE-ESTABLISH} = T_{RRC-RE-ESTABLISH} + T_{UE-RE-ESTABLISH-REQ-UNKNOWN}$$

where

$$T_{RRC-RE-ESTABLISH} = 160\text{ms} + (N_{313} - 1) * 10\text{ms} + T_{313}$$

$$T_{UE-RE-ESTABLISH-REQ-UNKNOWN} = 50\text{ms} + T_{\text{search}} * NF + T_{SI} + T_{RA}$$

$$N_{313} = 20$$

$$T_{313} = 0\text{s}$$

$$T_{\text{search}} = 800\text{ms}$$

NF is the number of different frequencies in the monitored set. 3 frequencies are assumed in this test case.

T_{RA} = The additional delay caused by the random access procedure. 40 ms is assumed in this test case.

T_{SI} is the time required for receiving all the relevant system information data according to the reception procedure and the RRC procedure delay of system information blocks defined in 25.331 for a UTRAN cell (ms). 1280 ms is assumed in this test case.

This gives a total of 4120ms, allow 4.2s in the test case.

8.4.1.2.3 Test purpose

To verify that the UE meets the minimum requirement.

8.4.1.2.4 Method of test

8.4.1.2.4.1 Initial conditions

Test environment: normal; see clauses G.2.1 and G.2.2.

Frequencies to be tested: mid range; see clause G.2.4.

The test parameters are given in table 8.4.1.3 and table 8.4.1.4 below. The maximum repetition period of the relevant system info blocks that needs to be received by the UE to camp on a cell shall be 1280 ms. And DRX cycle length shall be 1280ms. In the measurement control information it is indicated to the UE that periodic reporting shall be used. The test consists of 2 successive time periods, with a time duration of T1 and T2 respectively. At the start of time period T2, the dedicated channel is removed.

Table 8.4.1.3 General test parameters for RRC re-establishment delay, Test 2

Parameter	Unit	Value	Comment
DCH Parameters		DL and UL Reference measurement channel 12.2 kbps	As specified in clause C.3.1 and C.2.1
Power Control		On	
Active cell, initial condition		Cell 1	
Active cell, final condition		Cell 2	
N313		20	
N315		1	
T313	Seconds	0	
Monitored cell list size		24	Monitored set shall include 2 additional frequencies.
Cell 2			Cell 2 is not included in the monitored set. Cell 2 is located on one of the 2 additional frequencies of the monitored set.
Reporting frequency	Seconds	4	
T1	s	10	
T2	s	6	

Table 8.4.1.4 Cell specific parameters for RRC re-establishment delay test, Test 2

Parameter	Unit	Cell 1		Cell 2	
		T1	T2	T1	T2
Cell Frequency	ChNr	1		2	
CPICH_Ec/I _{or}	dB	-10		-10	
PCCPCH_Ec/I _{or}	dB	-12		-12	
SCH_Ec/I _{or}	dB	-12		-12	
PICH_Ec/I _{or}	dB	-15		-15	
DCH_Ec/I _{or}	dB	-17	-Infinity	Not applicable	
OCNS_Ec/I _{or}	dB	-1.049	-0.941	-0.941	
\hat{I}_{or}/I_{oc}	dB	-3,35	-Infinity	-Infinity	0,02
I_{oc}	dBm/ 3.84 MHz	-70			
CPICH_Ec/I _o	dB	-15	-Infinity	-Infinity	-13
Propagation Condition		AWGN			

8.4.1.2.4.2 Procedure

- 1) The RF parameters are set up according to T1.
- 2) The UE is switched on.

- 3) A call is set up according to the test procedure specified in TS 34.108 [3] subclause 7.3.4 without Compressed mode parameters.

[Editor's note: subclause 7.3.4 in TS 34.108 (Message sequence chart for Handover Test procedure) is not yet specified]

- 4) The SS waits for random access requests from the UE on cell 2.
- 5) 10 s after step3 has completed, the parameters are changed to that as described for T2.
- 6) If the UE responds on cell 2 within 4.3 s from the beginning of time period T2 with a CELL_UPDATE command then the number of successful tests is increased by one.
- 7) SS shall transmit a RRC CONNECTION RELEASE message to make the UE transit to idle mode.
- 8) After 6 seconds the RF parameters are set up according to T1.
- 9) The SS shall wait for 30s to make the UE complete cell reselection to cell1.
- 10) Repeat step 3-9 [TBD] times

NOTE: The time required for receiving all the relevant system information data according to the reception procedure and the RRC procedure delay of system information blocks defined in 25.331 for a UTRAN cell. Since the maximum repetition period of the relevant system info blocks that needs to be received by the UE to camp on a cell is 1280ms and the maximum RRC procedure delay for reception system information block is 100ms, 1380 ms is assumed in this test case. Therefore this gives a total of 4220ms (Minimum requirement + 100ms), allow 4.3s in the test case.

8.4.1.2.5 Test requirements

For the test to pass, the total number of successful tests shall be more than 90% with a confidence level of [FFS]% of the cases.

Note: If the above Test Requirement differs from the Minimum Requirement then the Test Tolerance applied for this test is non-zero. The Test Tolerance for this test is defined in clause F.2 and the explanation of how the Minimum Requirement has been relaxed by the Test Tolerance is given in clause F.4.

8.4.2 Random Access

8.4.2.1 Correct behaviour when receiving an ACK

8.4.2.1.1 Definition and applicability

The random access procedure is used when establishing the layer 1 communication between the UE and UTRAN. The random access shall provide a fast access but without disturbing ongoing connections. The random access is specified in clause 6 of TS 25.214 [5] and the control of the RACH transmission is specified in clause 11.2 of TS 25.321. A random access transmit sequence is described in clause 6.7.2 of TS 25.303.

8.4.2.1.2 Minimum Requirements

The UE shall have capability to calculate initial power according to the open loop algorithm and apply this power level at the first preamble and increase the power on additional preambles. The absolute power applied to the first preamble shall have an accuracy as specified in table 6.3 of TS 25.101 [1]. The relative power applied to additional preambles shall have an accuracy as specified in clause 6.5.2.1 of 25.101 [1].

The absolute power applied to the first preamble shall be -30 dBm with an accuracy as specified in clause 6.4.1.1 of TS 25.101 [1]. The accuracy is ± 9 dB in the case of normal condition or ± 12 dB in the case of extreme condition.

There are two relative powers, one is the power difference for preamble ramping and another is the power difference between last preamble part and message part. From the test parameter in the table 8.4.2.1.2, the test requirement of the power difference for all preamble ramping is 3dB (Power offset P0). The accuracy is ± 2 dB as specified in clause

6.5.2.1 of 25.101 [1]. The test requirement of the power difference between 10th preamble PRACH and message part is [3 dB] (note). The accuracy is $[\pm 2 \text{ dB}]$ as specified in clause 6.5.2.1 of 25.101 [1].

NOTE: In order to calculate the power difference between 10th preamble PRACH and message part by using Power offset P_{p-m} in the table 8.4.2.1.2, the gain factors of PRACH message part are needed. The gain factor β_d is set to 15. The [temporary] gain factor β_c is set to [15].

The UE shall stop transmitting preambles upon a ACK on the AICH has been received and then transmit a message. The UE shall transmit 10 preambles and 1 message.

The normative reference for this requirements is TS 25.133 [2] clauses 6.3.2 and A.6.2.2.1.

8.4.2.1.3 Test purpose

The purpose of this test is to verify that the behaviour of the random access procedure is according to the requirements and that the PRACH power settings are within specified limits.

8.4.2.1.4 Method of test

8.4.2.1.4.1 Initial conditions

Test environment: normal, TL/VL, TL/VH, TH/VL, TH/VH; see clauses G.2.1 and G.2.2.

Frequencies to be tested: mid range; see clause G.2.4.

- 1) Connect the SS to the UE antenna connector as shown in figure A.1 in the case of the PRACH power measurement. And in the case of the function test of the random access procedure, connect the SS to the UE antenna connector as shown in figure A.8. A spectrum analyzer is set to 0 span mode.
- 2) A call is set up according to the Generic call setup procedure. The test parameters are set up according to table 8.4.2.1.1, table 8.4.2.1.2 and table 8.4.2.1.3. The PRACH procedure within the call setup is used for the test. It is necessary that an ACK on the AICH shall be transmitted after 10 preambles have been received by the SS

See TS 34.108 [3] for details regarding generic call setup procedure.

Table 8.4.2.1.1: RF Parameters for Random Access test

Parameter	Unit	Cell 1
UTRA RF Channel Number		Channel 1
CPICH_Ec/Ior	dB	-10
PCCPCH_Ec/Ior	dB	-12
SCH_Ec/Ior	dB	-12
Number of other transmitted Acquisition Indicators	-	0
AICH_Ec/Ior	dB	-10
PICH_Ec/Ior	dB	-15
OCNS_Ec/Ior when an AI is not transmitted	dB	-0,941
OCNS_Ec/Ior when an AI is transmitted	dB	-1,516
\hat{I}_{or}/I_{oc}	dB	0
I_{oc}	dBm/3.84 MHz	-70
CPICH_Ec/Io	dB	-13
Propagation Condition		AWGN

The test parameters "System Information Block (SIB) type 5 (ASC #0)" defined in clause 6.1 of TS 34.108 [3], shall be used in all random access tests (see note). Crucial parameters for the test requirements are repeated in tables 8.4.2.1.2 and A.8.4.3.1.3 and these overrule the parameters defined in SIB type 5.

NOTE: A parameter of AC-to-ASC mapping(AC0-9) in SIB5 of clause 6.1 of TS 34.108 [3] shall be set to 0 in the case of all random access tests. The EFACC of Type A, which is specified in clause 8.3.2.15 of TS 34.108 [3], shall be selected.

Table 8.4.2.1.2: UE parameters for Random Access test

Parameter	Unit	Value
Access Service Class (ASC#0) - Persistence value	0..1	1
Maximum number of preamble ramping cycles (M_{max}).		2
Maximum number of preambles in one preamble ramping cycle (Preamble Retrans Max)		12
The backoff time T_{B01} $N_{B01min}=N_{B01max}$	ms #TTI	N/A 10
Power step when no acquisition indicator is received (Power offset P0)	dB	3
Power offset between the last transmitted preamble and the control part of the message (Power offset P p-m)	dB	0
Maximum allowed UL TX power	dBm	0

Table 8.4.2.1.3: SS parameters for Random Access test

Parameter	Unit	Value
Primary CPICH DL TX power	dBm	-8
UL interference	dBm	-102
SIR in open loop power control (Constant value)	dB	0
AICH Power Offset	dB	0

8.4.2.1.4.2 Procedure

- 1) Set the TX output level of the SS to obtain \hat{I}_{or} at the UE antenna connector. \hat{I}_{or} shall be according to table 8.4.2.1.1.
- 2) Measure the first PRACH preamble output power, the each power difference for preamble ramping and the power difference between 10th preamble PRACH and message part of the UE according to annex B.
- 3) Measure the number of the preamble part and the message part by using a spectrum analyzer.

8.4.2.1.5 Test requirements

The absolute power and the relative power shall meet the requirements in the minimum requirements in clause 8.4.2.1.2. The accuracy of the first preamble as specified in clause 6.4.1.1 of TS 25.101 [1] shall not be verified in this test. It is verified under the section 5.4.1, Open loop power control.

The UE shall stop transmitting preambles upon a ACK on the AICH has been received and then transmit a message. The UE shall transmit 10 preambles and 1 message.

NOTE: If the above Test Requirement differs from the Minimum Requirement then the Test Tolerance applied for this test is non-zero. The Test Tolerance for this test is defined in clause F.2 and the explanation of how the Minimum Requirement has been relaxed by the Test Tolerance is given in clause F.4.

8.4.2.2 Correct behaviour when receiving an NACK

8.4.2.2.1 Definition and applicability

The random access procedure is used when establishing the layer 1 communication between the UE and UTRAN. The random access shall provide a fast access but without disturbing ongoing connections. The random access is specified in clause 6 of TS 25.214 and the control of the RACH transmission is specified in clause 11.2 of TS 25.321. A random access transmit sequence is described in clause 6.7.2 of TS 25.303.

8.4.2.2.2 Minimum Requirements

The UE shall stop transmitting preambles upon a NACK on the AICH has been received and then repeat the ramping procedure when the back off timer T_{B01} expires.

The UE shall transmit 10 preambles in the first ramping cycle and no transmission shall be done by the UE within 100 ms after the NACK has been transmitted by the SS. Then the UE shall start the second preamble ramping cycle.

The normative reference for this requirements is TS 25.133 [2] clauses 6.3.2 and A.6.2.2.2.

8.4.2.2.3 Test purpose

The purpose of this test is to verify that the behaviour of the random access procedure is according to the requirements.

8.4.2.2.4 Method of test

8.4.2.2.4.1 Initial conditions

Test environment: normal, TL/VL, TL/VH, TH/VL, TH/VH; see clauses G.2.1 and G.2.2.

Frequencies to be tested: mid range; see clause G.2.4.

- 1) Connect the SS to the UE antenna connector as shown in figure A.8. A spectrum analyzer is set to 0 span mode.
- 2) A call is set up according to the Generic call setup procedure. The test parameters are set up according to table 8.4.2.1.1, table 8.4.2.1.2 and table 8.4.2.1.3. The PRACH procedure within the call setup is used for the test. It is necessary that an NACK on the AICH shall be transmitted after 10 preambles have been received by the SS.

See TS 34.108 [3] for details regarding generic call setup procedure.

8.4.2.2.4.2 Procedure

- 1) Set the TX output level of the SS to obtain \hat{I}_{Or} at the UE antenna connector. \hat{I}_{Or} shall be according to table 8.4.2.1.1.
- 2) Measure the number of the preamble part and the time delay between 10th preamble in the first ramping cycle and first preamble in the second ramping cycle by using a spectrum analyzer.

8.4.2.2.5 Test requirements

The UE shall stop transmitting preambles upon a NACK on the AICH has been received and then repeat the ramping procedure when the back off timer T_{B01} expires.

The UE shall transmit 10 preambles in the first ramping cycle and no transmission shall be done by the UE within 100 ms after the NACK has been transmitted by the SS. Then the UE shall start the second preamble ramping cycle.

NOTE: If the above Test Requirement differs from the Minimum Requirement then the Test Tolerance applied for this test is non-zero. The Test Tolerance for this test is defined in clause F.2 and the explanation of how the Minimum Requirement has been relaxed by the Test Tolerance is given in clause F.4.

8.4.2.3 Correct behaviour at Time-out

8.4.2.3.1 Definition and applicability

The random access procedure is used when establishing the layer 1 communication between the UE and UTRAN. The random access shall provide a fast access but without disturbing ongoing connections. The random access is specified in clause 6 of TS 25.214 and the control of the RACH transmission is specified in clause 11.2 of TS 25.321. A random access transmit sequence is described in clause 6.7.2 of TS 25.303.

8.4.2.3.2 Minimum Requirements

The UE shall stop transmit preambles when reaching the maximum number of preambles allowed in a cycle. The UE shall then repeat the ramping procedure until the maximum number of preamble ramping cycles are reached. No ACK/NACK shall be sent by SS during this test.

The UE shall transmit 2 preambles cycles, consisting of 12 preambles in each preamble cycle.

The normative reference for this requirements is TS 25.133 [2] clauses 6.3.2 and A.6.2.2.3.

8.4.2.3.3 Test purpose

The purpose of this test is to verify that the behaviour of the random access procedure is according to the requirements.

8.4.2.3.4 Method of test

8.4.2.3.4.1 Initial conditions

Test environment: normal, TL/VL, TL/VH, TH/VL, TH/VH; see clauses G.2.1 and G.2.2.

Frequencies to be tested: mid range; see clause G.2.4.

- 1) Connect the SS to the UE antenna connector as shown in figure A.8. A spectrum analyzer is set to 0 span mode.
- 2) A call is set up according to the Generic call setup procedure. The test parameters are set up according to table 8.4.2.1.1, table 8.4.2.1.3 and table 8.4.2.1.4. The PRACH procedure within the call setup is used for the test. It is necessary that SS shall transmit no AICH.

See TS 34.108 [3] for details regarding generic call setup procedure.

Table 8.4.2.1.4: UE parameters for correct behaviour at Time-out test

Parameter	Unit	Value
Access Service Class (ASC#0) - Persistence value	0..1	1
Maximum number of preamble ramping cycles (M_{max}).		2
Maximum number of preambles in one preamble ramping cycle (Preamble Retrans Max)		12
The backoff time T_{B01} $N_{B01min}=N_{B01max}$	ms #TTI	N/A 10
Power step when no acquisition indicator is received (Power offset P0)	dB	3
Power offset between the last transmitted preamble and the control part of the message (Power offset P p-m)	dB	0
Maximum allowed UL TX power	dBm	21

8.4.2.3.4.2 Procedure

- 1) Set the TX output level of the SS to obtain \hat{I}_{or} at the UE antenna connector. \hat{I}_{or} shall be according to table 8.4.2.1.1.
- 2) Measure the number of the preamble part by using a spectrum analyzer.

8.4.2.3.5 Test requirements

The UE shall stop transmit preambles when reaching the maximum number of preambles allowed in a cycle. The UE shall then repeat the ramping procedure until the maximum number of preamble ramping cycles are reached. No ACK/NACK shall be sent by SS during this test.

The UE shall transmit 2 preamble cycles, consisting of 12 preambles in each preamble cycle.

NOTE: If the above Test Requirement differs from the Minimum Requirement then the Test Tolerance applied for this test is non-zero. The Test Tolerance for this test is defined in clause F.2 and the explanation of how the Minimum Requirement has been relaxed by the Test Tolerance is given in clause F.4.

8.4.2.4 Correct behaviour when reaching maximum transmit power

8.4.2.4.1 Definition and applicability

The random access procedure is used when establishing the layer 1 communication between the UE and UTRAN. The random access shall provide a fast access but without disturbing ongoing connections. The random access is specified in clause 6 of TS 25.214 and the control of the RACH transmission is specified in clause 11.2 of TS 25.321. A random access transmit sequence is described in clause 6.7.2 of TS 25.303.

8.4.2.4.2 Minimum Requirements

The UE shall not exceed the maximum allowed UL TX power configured by the SS. No ACK/NACK shall be sent by SS during this test.

The absolute power of any preambles belonging to the first or second preamble cycle shall not exceed 0 dBm with more than specified in section 6.5 of TS 25.133.

The normative reference for this requirements is TS 25.133 [2] clauses 6.3.2 and A.6.2.2.4.

8.4.2.4.3 Test purpose

The purpose of this test is to verify that the PRACH power settings are within specified limits.

8.4.2.4.4 Method of test

8.4.2.4.4.1 Initial condition

Test environment: normal, TL/VL, TL/VH, TH/VL, TH/VH; see clauses G.2.1 and G.2.2.

Frequencies to be tested: mid range; see clause G.2.4.

- 1) Connect the SS to the UE antenna connector as shown in figure A.1.
- 2) A call is set up according to the Generic call setup procedure. The test parameters are set up according to table 8.4.2.1.1, table 8.4.2.1.2 and table 8.4.2.1.3. The PRACH procedure within the call setup is used for the test. It is necessary that SS shall transmit no AICH.

See TS 34.108 [3] for details regarding generic call setup procedure.

8.4.2.4.4.2 Procedure

- 1) Set the TX output level of the SS to obtain \hat{I}_{or} at the UE antenna connector. \hat{I}_{or} shall be according to table 8.4.2.1.1.
- 2) Measure the all PRACH preamble output power of the UE according to annex B.

8.4.2.4.5 Test requirements

The UE shall not exceed the maximum allowed UL TX power configured by the SS. No ACK/NACK shall be sent by SS during this test.

The absolute power of any preambles belonging to the first or second preamble cycle shall not exceed 0 dBm with more than the tolerance specified in section 6.5 of TS 25.133.

NOTE: If the above Test Requirement differs from the Minimum Requirement then the Test Tolerance applied for this test is non-zero. The Test Tolerance for this test is defined in clause F.2 and the explanation of how the Minimum Requirement has been relaxed by the Test Tolerance is given in clause F.4.

8.4.3 Transport format combination selection in UE

8.4.3.1 Interactive or Background, PS, UL: 64 kbps

8.4.3.1.1 Definition and applicability

When the UE estimates that a certain TFC would require more power than the maximum transmit power, it shall limit the usage of transport format combinations for the assigned transport format set, according to the functionality specified in section 11.4 in TS25.321 [13]. This in order to make it possible for the network operator to maximise the coverage. Transport format combination selection is described in section 11.4 of TS 25.321 [13].

8.4.3.1.2 Minimum requirements

The UE shall continuously evaluate based on the *Elimination*, *Recovery* and *Blocking* criteria defined below, how TFCs on an uplink DPDCH can be used for the purpose of TFC selection. The evaluation shall be performed for every TFC in the TFCS using the estimated UE transmit power of a given TFC. The UE transmit power estimation for a given TFC shall be made using the UE transmitted power measured over the measurement period, defined in 9.1.6.1 of TS 25.133 [2] as one slot, and the gain factors of the corresponding TFC.

The UE shall consider the *Elimination* criterion for a given TFC to be detected if the estimated UE transmit power needed for this TFC is greater than the Maximum UE transmitter power for at least X out of the last Y successive measurement periods immediately preceding evaluation. The MAC in the UE shall consider that the TFC is in Excess-Power state for the purpose of TFC selection.

MAC in the UE shall indicate the available bit rate for each logical channel to upper layers within T_{notify} from the moment the *Elimination* criterion was detected.

The UE shall consider the *Recovery* criterion for a given TFC to be detected if the estimated UE transmit power needed for this TFC has not been greater than the Maximum UE transmitter power for the last Z successive measurement periods immediately preceding evaluation. The MAC in the UE shall consider that the TFC is in Supported state for the purpose of TFC selection.

MAC in the UE shall indicate the available bitrate for each logical channel to upper layers within T_{notify} from the moment the *Recovery* criterion was detected.

The evaluation of the *Elimination* criterion and the *Recovery* criterion shall be performed at least once per radio frame.

The definitions of the parameters X,Y and Z which shall be used when evaluating the *Elimination* and the *Recovery* criteria when no compressed mode patterns are activated are given in Table 8.4.3.1.1.

Table 8.4.3.1.1: X, Y, Z parameters for TFC selection

X	Y	Z
15	30	30

The UE shall consider the *Blocking* criterion for a given TFC to be fulfilled at the latest at the start of the longest uplink TTI after the moment at which the TFC will have been in Excess-Power state for a duration of:

$$(T_{\text{notify}} + T_{\text{modify}} + T_{\text{L1_proc}})$$

where:

T_{notify} equals 15 ms

T_{modify} equals $\text{MAX}(T_{\text{adapt_max}}, T_{\text{TTI}})$

$T_{\text{L1_proc}}$ equals 15 ms

$T_{\text{adapt_max}}$ equals $\text{MAX}(T_{\text{adapt_1}}, T_{\text{adapt_2}}, \dots, T_{\text{adapt_N}})$

N equals the number of logical channels that need to change rate

$T_{\text{adapt_n}}$ equals the time it takes for higher layers to provide data to MAC in a new supported bitrate, for logical channel n. Table 8.4.3.1.2 defines T_{adapt} times for different services. For services where no codec is used T_{adapt} shall be considered to be equal to 0 ms.

Table 8.4.3.1.2: T_{adapt}

Service	T_{adapt} [ms]
UMTS AMR	40
UMTS AMR2	60

T_{TTI} equals the longest uplink TTI of the selected TFC (ms).

The Maximum UE transmitter power is defined as follows

Maximum UE transmitter power = $\text{MIN}(\text{Maximum allowed UL TX Power}, \text{UE maximum transmit power})$

where

Maximum allowed UL TX Power is set by SS and defined in TS 25.331 [8], and

UE maximum transmit power is defined by the UE power class, and specified in TS 25.101 [1].

The normative reference for these requirements is TS 25.133 [2] clauses 6.4.2 and A.6.4.1.

8.4.3.1.3 Test purpose

The purpose is to verify the UE blocks (stops using) a currently used TFC when the UE output power is not sufficient to support that TFC. The test will verify the general requirement on TFC selection in section 8.4.3.1.2 for a RAB intended for packet data services, i.e. Interactive or Background, PS, UL: 64kbps as defined in TS 34.108 [3].

8.4.3.1.4 Method of test

8.4.3.1.4.1 Initial conditions

Test environment: normal, TL/VL, TL/VH, TH/VL, TH/VH; see clauses G.2.1 and G.2.2.

Frequencies to be tested: mid range; see clause G.2.4.

The test parameters are given in Table 8.4.3.1.3, 8.4.3.1.4 and Table 8.4.3.1.5 below. The test consists of 2 successive time periods, with a time duration of T1 and T2 respectively.

Details on the UL reference RAB in table 8.4.3.1.3 and 8.4.3.1.4 can be found in TS 34.108 [3] section "Interactive or background / UL:64 DL: 64 kbps / PS RAB + UL:3.4 DL:3.4 kbps SRBs for DCCH".

Table 8.4.3.1.3: UL reference RAB, Interactive or Background

	TFI	64 kbps RAB (20ms TTI)	DCCH 3.4kbps (40ms TTI)
TFS	TF0, bits	0x336	0x148
	TF1, bits	1x336	1x148
	TF2, bits	2x336	N/A
	TF3, bits	3x336	N/A
	TF4, bits	4x336	N/A

Table 8.4.3.1.4: UL TFCI

TFCI	(64 kbps RAB, DCCH)
UL_TFC0	(TF0, TF0)
UL_TFC1	(TF0, TF1)
UL_TFC2	(TF1, TF0)
UL_TFC3	(TF1, TF1)
UL_TFC4	(TF2, TF0)
UL_TFC5	(TF2, TF1)
UL_TFC6	(TF3, TF0)
UL_TFC7	(TF3, TF1)
UL_TFC8	(TF4, TF0)
UL_TFC9	(TF4, TF1)

Table 8.4.3.1.5: General test parameters

Parameter	Unit	Value	Comment
TFCS size		10	
TFCS		UL_TFC0, UL_TFC1, UL_TFC2, UL_TFC3, UL_TFC4, UL_TFC5, UL_TFC6, UL_TFC7, UL_TFC8, UL_TFC9	
Power Control		On	
Active cell		Cell 1	
Maximum allowed UL TX power	dBm	21	
T1	s	30	
T2	s	10	
Propagation condition		AWGN	

The radio conditions in the test shall be sufficient, so that decoding of the TPC commands can be made without errors.

The amount of available user data shall be sufficient to allow uplink transmission at the highest bit rate (UL_TFC8 or UL_TFC9) during the entire test and it shall be ensured that the UE is using UL_TFC8 or UL_TFC9 at the end of T1.

8.4.3.1.4.2 Procedure

- 1) The UE is switched on.
- 2) The SS shall signal to the UE the allowed TFCS according to table 8.4.3.1.5.
- 3) For T1=30 secs the SS shall command the UE output power to be between 14 and 15 dB below the UE Maximum allowed UL Tx power (table 8.4.3.1.5).
- 4) The SS shall start sending continuously TPC_cmd=1 to the UE for T2=10 secs (see NOTE).
- 5) The time from the beginning of T2 until the UE blocks (stops using) UL_TFC8 and UL_TFC9 shall be measured by the SS. The UE shall stop using UL_TFC8 and UL_TFC9 within 140 ms from beginning of time period T2.
- 6) Repeat steps 3-5 [50] times.

NOTE: This will emulate that UL_TFC8 to UL_TFC9 can not be supported because the UE reaches the maximum UL Tx power and still SS is sending power-up commands.

8.4.3.1.5 Test requirements

For the test to pass, the total number of successful tests shall be more than 90% with a confidence level of [FFS]% of the cases.

Note: If the above Test Requirement differs from the Minimum Requirement then the Test Tolerance applied for this test is non-zero. The Test Tolerance for this test is defined in clause F.2 and the explanation of how the Minimum Requirement has been relaxed by the Test Tolerance is given in clause F.4.

8.5 Timing and Signalling Characteristics

8.5.1 UE Transmit Timing

8.5.1.1 Definition and applicability

The UE transmit timing is defined as the timing of the uplink DPCCH/DPDCH frame relative to the first detected path (in time) of the corresponding downlink DPCCH/DPDCH frame from the reference cell. The reference point is the antenna connector of the UE.

The requirements and this test apply to all types of UTRA of the FDD UE.

8.5.1.2 Minimum requirements

The UE transmission timing error shall be less than or equal to ± 1.5 chips. The reference point for the UE initial transmit timing control requirement shall be the time when the first detected path (in time) of the corresponding downlink DPCCH/DPDCH frame is received from the reference cell plus T_0 chips. T_0 is defined in TS25.211 [19].

When the UE is not in soft handover, the reference cell shall be the one the UE has in the active set. The cell, which is selected as a reference cell, shall remain as a reference cell even if other cells are added to the active set. In case that the reference cell is removed from the active set the UE shall start adjusting its transmit timing no later than the time when the whole active set update message is available at the UE taking the RRC procedure delay into account.

The UE shall be capable of changing the transmission timing according the received downlink DPCCH/DPDCH frame. The maximum amount of the timing change in one adjustment shall be $\frac{1}{4}$ chip.

The minimum adjustment rate shall be 233ns per second. The maximum adjustment rate shall be ¼ chip per 200 ms. In particular, within any given 800*d ms period, the UE transmit timing shall not change in excess of $\pm d$ chip from the timing at the beginning of this 800*d ms period, where $0 \leq d \leq 1/4$.

The normative reference for this requirement is TS 25.133 [2] clause 7.1.2.

8.5.1.3 Test purpose

The purpose of this test is to verify that the UE initial transmit timing accuracy, maximum amount of timing change in one adjustment, minimum and maximum adjustment rate are within the limits specified in 8.5.1.2.

8.5.1.4 Method of test

8.5.1.4.1 Initial conditions

Test environment: normal; see clauses G.2.1 and G.2.2.

Frequencies to be tested: mid range; see clause G.2.4.

For this test, two cells on the same frequency are used.

- 1) Connect the test system to the UE antenna connector as shown in figure A.1.
- 2) A call is set up with Cell 1 according to the Generic call setup procedure. The test parameters are set up according to table 8.5.1.1.

Table 8.5.1.1: Test parameters for UE Transmit Timing requirements

Parameter	Unit	Level
DPCH_Ec/lor, Cell 1 and Cell 2	dB	-17
CPICH_Ec/lor, Cell 1 and Cell 2	dB	-10
PCCPH_Ec/lor, Cell 1 and Cell 2	dB	-12
SCH_Ec/lor, Cell 1 and Cell 2	dB	-12
PICH_Ec/lor, Cell 1 and Cell 2	dB	-15
OCNS_Ec/lor, Cell 1 and Cell 2	dB	-1.05
\hat{I}_{or} , Cell 1	dBm/3.84 MHz	-96
\hat{I}_{or} , Cell 2	dBm/3.84 MHz	-99
Information data rate	kbps	12.2
Relative delay of path received from cell 2 with respect to cell 1	μ s	+/-2
Propagation condition	AWGN	

8.5.1.4.2 Procedure

- a) After a connection is set up with cell 1, the test system shall verify that the UE transmit timing offset is within $T_0 \pm 1.5$ chips with respect to the first detected path (in time) of the downlink DPCCH/DPDCH of cell 1.
- b) Test system introduces cell 2 into the test system at delay $+2 \mu$ s from cell 1.
- c) Test system verifies that cell 2 is added to the active set.
- d) Test system shall verify that the UE transmit timing offset is still within $T_0 \pm 1.5$ chips with respect to the first detected path (in time) of the downlink DPCCH/DPDCH of cell 1.
- e) Test system switches Tx timing of cell 2 to a delay of -2μ s with respect to cell 1.
- f) Test system verifies cell 2 remains in the active set.
- g) Test system shall verify that the UE transmit timing offset is still within $T_0 \pm 1.5$ chips with respect to the first detected path (in time) of the downlink DPCCH/DPDCH of cell 1.
- h) Test system stops sending cell 1 signals.

- i) Void
- j) Test system verifies that UE transmit timing adjustment starts no later than the time when the whole active set update message is available at the UE taking the RRC procedure delay into account. The adjustment step size and the adjustment rate shall be according to the requirements in clause 8.5.1.2 until the UE transmit timing offset is within $T_0 \pm 1.5$ chips with respect to the first detected path (in time) of the downlink DPCCH/DPDCH of cell 2.
- k) Test system shall verify that the UE transmit timing offset stays within $T_0 \pm 1.5$ chips with respect to the first detected path (in time) of the downlink DPCCH/DPDCH of cell 2.
- l) Test system starts sending cell 1 signal again with its original timing.
- m) Test system verifies that cell 1 is added to the active set.
- n) Test system verifies that the UE transmit timing is still within $T_0 \pm 1.5$ chips with respect to the first detected path (in time) of the downlink DPCCH/DPDCH of cell 2.
- o) Test system stops sending cell 2 signals.
- p) Void.
- q) Test system verifies that UE transmit timing adjustment starts no later than the time when the whole active set update message is available at the UE taking the RRC procedure delay into account. The adjustment step size and the adjustment rate shall be according to the requirements in clause 8.5.1.2 until the UE transmit timing offset is within $T_0 \pm 1.5$ chips with respect to the first detected path (in time) of the downlink DPCCH/DPDCH of cell 1.
- r) Test system shall verify that the UE transmit timing offset stays within $T_0 \pm 1.5$ chips with respect to the first detected path (in time) of the downlink DPCCH/DPDCH of cell 1.

8.5.1.5 Test requirements

- 1) In step a), d) and g), UE transmit timing offset shall be within $T_0 \pm 1.5$ chips with respect to the first detected path (in time) of the downlink DPCCH/DPDCH of cell 1.
- 2) In step j), the adjustment step size and the adjustment rate shall meet the requirements specified in 8.5.1.2 until the UE transmit timing offset is within $T_0 \pm 1.5$ chips with respect to the first detected path (in time) of the downlink DPCCH/DPDCH of cell 2.
- 3) In step k) and n), UE transmit timing offset shall be within $T_0 \pm 1.5$ chips with respect to the first detected path (in time) of the downlink DPCCH/DPDCH of cell 2.
- 4) In step q), the adjustment step size and the adjustment rate shall meet the requirements specified in 8.5.1.2 until the UE transmit timing offset is within $T_0 \pm 1.5$ chips with respect to the first detected path (in time) of the downlink DPCCH/DPDCH of cell 1.
- 5) In step r), UE transmit timing offset shall be within $T_0 \pm 1.5$ chips with respect to the first detected path (in time) of the downlink DPCCH/DPDCH of cell 1.

NOTE 1: The above Test Requirement differs from the Test Requirement of TS 25.133 [2] clause A7.1.2, from which the requirements for the test system are subtracted to give the above Test Requirement.

NOTE 2: If the above Test Requirement differs from the Minimum Requirement then the Test Tolerance applied for this test is non-zero. The Test Tolerance for this test is defined in clause F.2 and the explanation of how the Minimum Requirement has been relaxed by the Test Tolerance is given in clause F.4.

8.6 UE Measurements Procedures

8.6.1 FDD intra frequency measurements

8.6.1.1 Event triggered reporting in AWGN propagation conditions

8.6.1.1.1 Definition and applicability

In the event triggered reporting period the measurement reporting delay is defined as the time between any event that will trigger a measurement report until the UE starts to transmit over the Uu interface. This requirement assumes that the measurement report is not delayed by other RRC signalling on the DCCH. This measurement reporting delay excludes a delay uncertainty resulted when inserting the measurement report to the TTI of the uplink DCCH. The delay uncertainty is twice the TTI of the uplink DCCH.

The requirements and this test apply to the FDD UE.

8.6.1.1.2 Minimum requirements

The UE shall be able to identify and decode the SFN of a new detectable cell belonging to the monitored set within

$$T_{\text{identify intra}} = \text{Max} \left\{ 800, T_{\text{basic identify FDD, intra}} \cdot \frac{T_{\text{Measurement Period, Intra}}}{T_{\text{Intra}}} \right\} \text{ms}$$

A cell shall be considered detectable when CPICH Ec/Io ≥ -20 dB, SCH_Ec/Io ≥ -20 dB for at least one channel tap and SCH_Ec/Ior is equally divided between primary synchronisation code and secondary synchronisation code. When L3 filtering is used an additional delay can be expected.

In the CELL_DCH state the measurement period for intra frequency measurements is 200 ms. When no transmission gap pattern sequence is activated, the UE shall be capable of performing CPICH measurements for 8 identified intra-frequency cells of the monitored set and/or the active set, and the UE physical layer shall be capable of reporting measurements to higher layers with the measurement period of 200 ms. When one or more transmission gap pattern sequences are activated, the UE shall be capable of performing CPICH measurements for at least $Y_{\text{measurement intra}}$ cells, where $Y_{\text{measurement intra}}$ is defined in the following equation. The measurement accuracy for all measured cells shall be as specified in the sub-clause 9.1.1 and 9.1.2 of TS 25.133 [2]. If the UE has identified more than $Y_{\text{measurement intra}}$ cells, the UE shall perform measurements of all identified cells but the reporting rate of CPICH measurements of cells from UE physical layer to higher layers may be decreased.

$$Y_{\text{measurement intra}} = \text{Floor} \left\{ X_{\text{basic measurement FDD}} \cdot \frac{T_{\text{Intra}}}{T_{\text{Measurement Period, Intra}}} \right\} \text{ cells}$$

where

$$X_{\text{basic measurement FDD}} = 8 \text{ (cells)}$$

$$T_{\text{Measurement_Period Intra}} = 200 \text{ ms. The measurement period for Intra frequency CPICH measurements.}$$

T_{Intra} : This is the minimum time that is available for intra frequency measurements, during the measurement period with an arbitrarily chosen timing.

$T_{\text{basic_identify_FDD, intra}} = 800 \text{ ms. This is the time period used in the intra frequency equation where the maximum allowed time for the UE to identify a new FDD cell is defined.}$

The event triggered measurement reporting delay, on cells belonging to monitored set, measured without L3 filtering, shall be less than the above defined $T_{\text{identify intra}}$ defined above.

If a cell, belonging to monitored set, which the UE has identified and measured at least once over the measurement period, becomes undetectable for a period < 5 seconds and then the cell becomes detectable again and triggers an event, the measurement reporting delay shall be less than $T_{\text{Measurement_Period Intra}}$ ms provided the timing to that cell has not

changed more than +/-32 chips, the UE CPICH measurement capabilities defined above are valid and L3 filtering has not been used. When L3 filtering is used an additional delay can be expected.

If a cell belonging to monitored set has been detectable at least for the time period $T_{\text{identify_intra}}$ and then enters or leaves the reporting range, the event triggered measurement reporting delay shall be less than $T_{\text{Measurement_Period Intra}}$ when the L3 filter has not been used and the UE CPICH measurement capabilities defined above are valid.

The normative reference for these requirements is TS 25.133 [2] clauses 8.1.2.2 and A.8.1.1.

8.6.1.1.3 Test purpose

To verify that the UE meets the minimum requirements.

8.6.1.1.4 Method of test

8.6.1.1.4.1 Initial conditions

Test environment: normal; see clauses G.2.1 and G.2.2.

Frequencies to be tested: mid range; see clause G.2.4.

The test parameters are given in table 8.6.1.1.1 and 8.6.1.1.2 below. In the measurement control information it is indicated to the UE that event-triggered reporting with Event 1A and 1B shall be used. The test consists of three successive time periods, with a time duration of T1, T2 and T3 respectively. During time duration T1, the UE shall not have any timing information of cell 2.

Table 8.6.1.1.1: General test parameters for Event triggered reporting in AWGN propagation conditions

Parameter	Unit	Value	Comment
DCH parameters		DL and UL Reference Measurement Channel 12.2 kbps	As specified in C.3.1 and C.2.1
Power Control		On	
Active cell		Cell 1	
Reporting range	dB	3	Applicable for event 1A and 1B
Hysteresis	dB	0	
W		1	Applicable for event 1A and 1B
Reporting deactivation threshold		0	Applicable for event 1A
Time to Trigger	ms	0	
Filter coefficient		0	
Monitored cell list size		24	
T1	s	5	
T2	s	5	
T3	s	5	

Table 8.6.1.1.2: Cell specific test parameters for Event triggered reporting in AWGN propagation conditions

Parameter	Unit	Cell 1			Cell 2		
		T1	T2	T3	T1	T2	T3
CPICH_Ec/I _{or}	dB		-10			-10	
PCCPCH_Ec/I _{or}	dB		-12			-12	
SCH_Ec/I _{or}	dB		-12			-12	
PICH_Ec/I _{or}	dB		-15			-15	
DPCH_Ec/I _{or}	dB		-17			N/A	
OCNS			-1.049			-0.941	
\hat{I}_{or}/I_{oc}	dB	0	6.97	0	-Infinity	5.97	-Infinity
I_{oc}	dBm/3.84 MHz	-70					
CPICH_Ec/I _o	dB	-13	-13	-13	-Infinity	-14	-Infinity
Propagation Condition		AWGN					

8.6.1.1.4.2 Procedure

1. The RF parameters are set up according to T1.
2. The UE is switched on.
3. A call is set up according to the test procedure specified in TS 34.108 [3] sub clause 7.3.2.3.
4. SS shall transmit a MEASUREMENT CONTROL message.
5. After 5 seconds from the beginning of T1, the SS shall switch the power settings from T1 to T2.
6. UE shall transmit a MEASUREMENT REPORT message triggered by event 1A. The measurement reporting delay from the beginning of T2 shall be less than 880 ms. If the UE fails to report the event within the required delay, then a failure is recorded. If the reporting delay for this event is within the required limit, the number of successful tests is increased by one.
7. After 5 seconds from the beginning of T2, the SS shall switch the power settings from T2 to T3.
8. UE shall transmit a MEASUREMENT REPORT message triggered by event 1B. The measurement reporting delay from the beginning of T3 shall be less than 280 ms. If the reporting delay for this event is within the required limit, the number of successful tests is increased by one.
9. After 5 seconds from the beginning of T3, the UE is switched off. Any timing information of cell 2 is deleted in the UE.
10. Repeat steps 1-9 [50] times.

Specific Message Contents

All messages indicated above shall use the same content as described in the default message content in clause 9 of 34.108 [3], with the following exceptions:

MEASUREMENT CONTROL message:

Information Element/Group name	Value/Remark
Message Type (10.2.17)	
UE information elements	
-RRC transaction identifier	0
-Integrity check info	Not Present
Measurement Information elements	
-Measurement Identity	1
-Measurement Command (10.3.7.46)	Modify
-Measurement Reporting Mode (10.3.7.49)	
-Measurement Report Transfer Mode	AM RLC
-Periodical Reporting / Event Trigger Reporting Mode	Event trigger
-Additional measurements list (10.3.7.1)	Not Present
-CHOICE <i>Measurement type</i>	Intra-frequency measurement
-Intra-frequency measurement (10.3.7.36)	
-Intra-frequency measurement objects list (10.3.7.33)	Not Present
-Intra-frequency measurement quantity (10.3.7.38)	
-Filter coefficient (10.3.7.9)	0
-CHOICE mode	FDD
-Measurement quantity	CPICH_Ec/N0
-Intra-frequency reporting quantity (10.3.7.41)	
-Reporting quantities for active set cells (10.3.7.5)	
-SFN-SFN observed time difference reporting indicator	No report
-Cell synchronisation information reporting indicator	TRUE (Note 1)
-Cell Identity reporting indicator	TRUE
-CHOICE mode	FDD
-CPICH Ec/N0 reporting indicator	TRUE
-CPICH RSCP reporting indicator	TRUE
-Pathloss reporting indicator	TRUE
-Reporting quantities for monitored set cells (10.3.7.5)	
-SFN-SFN observed time difference reporting indicator	No report
-Cell synchronisation information reporting indicator	TRUE (Note 1)
-Cell Identity reporting indicator	TRUE
-CHOICE mode	FDD
-CPICH Ec/N0 reporting indicator	TRUE
-CPICH RSCP reporting indicator	TRUE
-Pathloss reporting indicator	TRUE
-Reporting quantities for detected set cells (10.3.7.5)	Not Present
-Reporting cell status (10.3.7.61)	Not Present
-Measurement validity (10.3.7.51)	Not Present
-CHOICE report criteria	Intra-frequency measurement reporting criteria
-Intra-frequency measurement reporting criteria (10.3.7.39)	
-Parameters required for each event	2
-Intra-frequency event identity	Event 1A
-Triggering condition 2	Monitored set cells
-Reporting Range Constant	3 dB
-Cells forbidden to affect Reporting Range	Not Present
-CHOICE mode	FDD
-Primary CPICH info (10.3.6.60)	
-W	1.0
-Hysteresis	0 dB
-Threshold used frequency	Not Present
-Reporting deactivation threshold	0
-Replacement activation threshold	Not Present
-Time to trigger	0 ms
-Amount of reporting	Not present
-Reporting interval	0 ms (Note 2)
-Reporting cell status	Not Present
-Intra-frequency event identity	Event 1B
-Triggering condition 1	Active set cells and monitored set cells
-Reporting Range Constant	3 dB
-Cells forbidden to affect Reporting Range	Not Present
-CHOICE mode	FDD
-Primary CPICH info (10.3.6.60)	
-W	1.0
-Hysteresis	0 dB

Information Element/Group name	Value/Remark
-Threshold used frequency	Not Present
-Reporting deactivation threshold	Not Present
-Replacement activation threshold	Not Present
-Time to trigger	0 ms
-Amount of reporting	Not Present
-Reporting interval	0 ms (note 2)
-Reporting cell status	Not Present
Physical channel information elements	
-DPCH compressed mode status info (10.3.6.34)	Not Present
Note 1: The SFN-CFN observed time difference is calculated from the OFF and Tm parameters contained in the IE "Cell synchronisation information", TS 25.331, clause 10.3.7.6. According to TS 25.331, 8.6.7.7, this IE is included in MEASUREMENT REPORT if IE "Cell synchronisation information reporting indicator" in IE "Cell reporting quantities" TS 25.331, clause 10.3.7.5 is set to TRUE in MEASUREMENT CONTROL.	
Note 2: Reporting interval = 0 ms means no periodical reporting	

MEASUREMENT REPORT message for Intra frequency test cases

This message is common for all intra frequency test cases is described in Annex I.

8.6.1.1.5 Test requirements

For the test to pass, the total number of successful tests shall be at least 90%, with a confidence level of [FFS]% of the cases. The number of successful tests shall be on an event level, i.e. the SS shall check how many events are reported successfully out of the total number of events checked.

NOTE: If the above Test Requirement differs from the Minimum Requirement then the Test Tolerance applied for this test is non-zero. The Test Tolerance for this test is defined in clause F.2 and the explanation of how the Minimum Requirement has been relaxed by the Test Tolerance is given in clause F.4.

8.6.1.2 Event triggered reporting of multiple neighbours in AWGN propagation condition

8.6.1.2.1 Definition and applicability

In the event triggered reporting period the measurement reporting delay is defined as the time between any event that will trigger a measurement report until the UE starts to transmit over the Uu interface. This requirement assumes that the measurement report is not delayed by other RRC signalling on the DCCH. This measurement reporting delay excludes a delay uncertainty resulted when inserting the measurement report to the TTI of the uplink DCCH. The delay uncertainty is twice the TTI of the uplink DCCH.

The requirements and this test apply to the FDD UE.

8.6.1.2.2 Minimum requirements

The requirements are the same as in sub clause 8.6.1.1.2.

The normative reference for these requirements is TS 25.133 [2] clauses 8.1.2.2 and A.8.1.2.

8.6.1.2.3 Test purpose

To verify that the UE meets the minimum requirements.

8.6.1.2.4 Method of test

8.6.1.2.4.1 Initial conditions

Test environment: normal; see clauses G.2.1 and G.2.2.

Frequencies to be tested: mid range; see clause G.2.4.

The initial test parameters are given in table 8.6.1.2.1.

Table 8.6.1.2.1: Cell specific initial test parameters for Event triggered reporting of multiple neighbours in AWGN propagation conditions

Parameter	Unit	Cell 1	Cell 2	Cell3
		T0	T0	T0
CPICH_Ec/Ior	dB	-10	-10	-10
PCCPCH_Ec/Ior	dB	-12	-12	-12
SCH_Ec/Ior	dB	-12	-12	-12
PICH_Ec/Ior	dB	-15	-15	-15
DPCH_Ec/Ior	dB	-17	N/A	N/A
OCNS_Ec/Ior	dB	-1.049	-0.941	-0.941
\hat{I}_{or}/I_{oc}	dB	0	-Inf	-Inf
I_{oc}	dBm/ 3.84 MHz	-85		
CPICH_Ec/Io	dB	-13	-Inf	-Inf
Propagation Condition	AWGN			

The test parameters are given in table 8.6.1.2.2 and 8.6.1.2.3. In the measurement control information it is indicated to the UE that event-triggered reporting with Event 1A, 1C and 1B shall be used and the periodical reporting of the events is not applied. The test consists of four successive time periods, with a time duration of T1, T2, T3 and T4 respectively. In the initial condition before the time T1 only Cell1 is active.

Table 8.6.1.2.2: General test parameters for Event triggered reporting of multiple neighbours in AWGN propagation conditions

Parameter	Unit	Value	Comment
DCH parameters		DL and UL Reference Measurement Channel 12.2 kbps	As specified in C.3.1 and C.2.1
Power Control		On	
Active cell		Cell 1	
Reporting range	dB	3	Applicable for event 1A and 1B
Hysteresis	dB	0	
W		1	Applicable for event 1A and 1B
Replacement activation threshold		0	Applicable for event 1C
Reporting deactivation threshold		0	Applicable for event 1A
Time to Trigger	ms	0	
Filter coefficient		0	
Monitored cell list size		32	
T1	S	10	
T2	S	10	
T3	S	5	
T4	S	10	

Table 8.6.1.2.3: Cell specific test parameters for Event triggered reporting of multiple neighbours in AWGN propagation condition

Parameter	Unit	Cell 1				Cell 2				Cell3			
		T1	T2	T3	T4	T1	T2	T3	T4	T1	T2	T3	T4
CPICH_Ec/Ior	dB	-10				-10				-10			
PCCPCH_Ec/Ior	dB	-12				-12				-12			
SCH_Ec/Ior	dB	-12				-12				-12			
PICH_Ec/Ior	dB	-15				-15				-15			
DPCH_Ec/Ior	dB	-17				N/A				N/A			
OCNS_Ec/Ior	dB	-1.049				-0.941				-0.941			
\hat{I}_{or}/I_{oc}	dB	6.97	6.93	5.97	6.12	-Inf	9.43	6.97	7.62	5.97	6.93	-Inf	5.62
I_{oc}	dBm/ 3.84 MHz	-85											
CPICH_Ec/Io	dB	-13	-16	-14	-15.5	-Inf	-13.5	-13	-14	-14	-16	-Inf	-16
Propagation Condition	AWGN												

8.6.1.2.4.2 Procedure

- 1) The RF parameters are set up according to T0.
- 2) The UE is switched on.
- 3) A call is set up according to the test procedure specified in TS 34.108 [3] sub clause 7.3.2.3.
- 4) SS shall transmit a MEASUREMENT CONTROL message.
- 5) 5 seconds after step4 has completed, the SS shall switch the power settings for T0 to T1.
- 6) UE shall transmit a MEASUREMENT REPORT message for Cell 3 triggered by event 1A. The measurement reporting delay from the beginning of T1 shall be less than 880 ms. If the UE fails to report the event within the required delay, then a failure is recorded. If the reporting delay for this event is within the required limit, the number of successful tests is increased by one.
- 7) UE may transmit a MEASUREMENT REPORT message for Cell 3 triggered by event 1C. In case it doesn't this shall not be considered as a failure.
- 8) After 10 seconds from the beginning of T1, the SS shall switch the power settings from T1 to T2.
- 9) UE shall transmit a MEASUREMENT REPORT message for Cell 2 triggered by event 1C. The measurement reporting delay from the beginning of T2 shall be less than 880 ms. If the UE fails to report the event within the required delay, then a failure is recorded. If the reporting delay for this event is within the required limit, the number of successful tests is increased by one.
- 10) UE shall transmit a MEASUREMENT REPORT message for Cell 2 triggered by event 1A. The measurement reporting delay from the beginning of T2 shall be less than 880 ms. If the UE fails to report the event within the required delay, then a failure is recorded. If the reporting delay for this event is within the required limit, the number of successful tests is increased by one.
- 11) UE may transmit a MEASUREMENT REPORT message for Cell 3 triggered by event 1C. In case it doesn't this shall not be considered as a failure.
- 12) After 10 seconds from the beginning of T2, the SS shall switch the power settings from T2 to T3.
- 13) UE shall transmit a MEASUREMENT REPORT message for Cell 3 triggered by event 1B. The measurement reporting delay from the beginning of T3 shall be less than 280 ms. If the UE fails to report the event within the required delay, then a failure is recorded. If the reporting delay for this event is within the required limit, the number of successful tests is increased by one.
- 14) UE may transmit a MEASUREMENT REPORT message for Cell 2 triggered by event 1C. In case it doesn't this shall not be considered as a failure.

- 15) After 5 seconds from the beginning of T3, the SS shall switch the power settings from T3 to T4.
- 16) UE shall transmit a MEASUREMENT REPORT message for Cell 3 triggered by event 1A. The measurement reporting delay from the beginning of T4 shall be less than 280 ms. If the reporting delay for this event is within the required limit, the number of successful tests is increased by one.
- 17) UE may transmit a MEASUREMENT REPORT message for Cell 2 triggered by event 1C. In case it doesn't this shall not be considered as a failure.
- 18) UE may transmit a MEASUREMENT REPORT message for Cell 3 triggered by event 1C. In case it doesn't this shall not be considered as a failure.
- 19) After 10 seconds from the beginning of T4, the UE is switched off.
- 20) Repeat steps 1-19 [50] times.

Specific Message Contents

All messages indicated above shall use the same content as described in the default message content in clause 9 of 34.108 [3], with the following exceptions:

MEASUREMENT CONTROL message:

Information Element/Group name	Value/Remark
Message Type (10.2.17)	
UE information elements	
-RRC transaction identifier	0
-Integrity check info	Not Present
Measurement Information elements	
-Measurement Identity	1
-Measurement Command (10.3.7.46)	Modify
-Measurement Reporting Mode (10.3.7.49)	AM RLC
-Measurement Report Transfer Mode	Event trigger
-Periodical Reporting / Event Trigger Reporting Mode	Not Present
-Additional measurements list (10.3.7.1)	
-CHOICE <i>Measurement type</i>	Intra-frequency measurement
-Intra-frequency measurement (10.3.7.36)	Not Present
-Intra-frequency measurement objects list (10.3.7.33)	
-Intra-frequency measurement quantity (10.3.7.38)	
-Filter coefficient (10.3.7.9)	0
-CHOICE mode	FDD
-Measurement quantity	CPICH_Ec/N0
-Intra-frequency reporting quantity (10.3.7.41)	
-Reporting quantities for active set cells (10.3.7.5)	
-SFN-SFN observed time difference reporting indicator	No report
-Cell synchronisation information reporting indicator	TRUE (Note 1)
-Cell Identity reporting indicator	TRUE
-CHOICE mode	FDD
-CPICH Ec/N0 reporting indicator	TRUE
-CPICH RSCP reporting indicator	TRUE
-Pathloss reporting indicator	TRUE
-Reporting quantities for monitored set cells (10.3.7.5)	
-SFN-SFN observed time difference reporting indicator	No report
-Cell synchronisation information reporting indicator	TRUE (Note 1)
-Cell Identity reporting indicator	TRUE
-CHOICE mode	FDD
-CPICH Ec/N0 reporting indicator	TRUE
-CPICH RSCP reporting indicator	TRUE
-Pathloss reporting indicator	TRUE
-Reporting quantities for detected set cells (10.3.7.5)	Not Present
-Reporting cell status (10.3.7.61)	Not Present
-Measurement validity (10.3.7.51)	Not Present
-CHOICE report criteria	Intra-frequency measurement reporting criteria
-Intra-frequency measurement reporting criteria (10.3.7.39)	
-Parameters required for each event	3
-Intra-frequency event identity	Event 1A
-Triggering condition 2	Monitored set cells
-Reporting Range Constant	3 dB
-Cells forbidden to affect Reporting Range	Not Present
-W	1.0
-Hysteresis	0 dB
-Threshold used frequency	Not Present
-Reporting deactivation threshold	0
-Replacement activation threshold	Not Present
-Time to trigger	0 ms
-Amount of reporting	Not Present
-Reporting interval	0 ms (Note 2)
-Reporting cell status	Not Present
-Intra-frequency event identity	Event 1B
-Triggering condition 1	Active set cells and monitored set cells
-Reporting Range Constant	3 dB
-Cells forbidden to affect Reporting Range	Not Present
-W	1.0
-Hysteresis	0 dB
-Threshold used frequency	Not Present
-Reporting deactivation threshold	Not Present
-Replacement activation threshold	Not Present
-Time to trigger	0 ms

Information Element/Group name	Value/Remark
-Amount of reporting -Reporting interval -Reporting cell status	Not Present 0 ms (Note 2) Not Present
-Intra-frequency event identity -Triggering condition 2 -Reporting Range Constant -Cells forbidden to affect Reporting Range -W -Hysteresis -Threshold used frequency -Reporting deactivation threshold -Replacement activation threshold -Time to trigger -Amount of reporting -Reporting interval -Reporting cell status	Event 1C Active set cells and monitored set cells Not present Not Present Not present 0 dB Not Present Not present 0 0 ms Not Present 0 ms (Note 2) Not Present
Physical channel information elements -DPCH compressed mode status info (10.3.6.34)	Not Present
NOTE 1: The SFN-CFN observed time difference is calculated from the OFF and Tm parameters contained in the IE "Cell synchronisation information", TS 25.331, clause 10.3.7.6. According to TS 25.331, 8.6.7.7, this IE is included in MEASUREMENT REPORT if IE "Cell synchronisation information reporting indicator" in IE "Cell reporting quantities" TS 25.331, clause 10.3.7.5 is set to TRUE in MEASUREMENT CONTROL.	
NOTE 2: Reporting interval = 0 ms means no periodical reporting.	

MEASUREMENT REPORT message for Intra frequency test cases

This message is common for all intra frequency test cases is described in Annex I.

8.6.1.2.5 Test requirements

For the test to pass, the total number of successful tests shall be at least 90%, with a confidence level of [FFS]% of the cases. The number of successful tests shall be on an event level, i.e. the SS shall check how many events are reported successfully out of the total number of events checked.

NOTE: If the above Test Requirement differs from the Minimum Requirement then the Test Tolerance applied for this test is non-zero. The Test Tolerance for this test is defined in clause F.2 and the explanation of how the Minimum Requirement has been relaxed by the Test Tolerance is given in clause F.4.

8.6.1.3 Event triggered reporting of two detectable neighbours in AWGN propagation condition

8.6.1.3.1 Definition and applicability

In the event triggered reporting period the measurement reporting delay is defined as the time between any event that will trigger a measurement report until the UE starts to transmit over the Uu interface. This requirement assumes that the measurement report is not delayed by other RRC signalling on the DCCH. This measurement reporting delay excludes a delay uncertainty resulted when inserting the measurement report to the TTI of the uplink DCCH. The delay uncertainty is twice the TTI of the uplink DCCH.

The requirements and this test apply to the FDD UE.

8.6.1.3.2 Minimum requirements

The requirements are the same as in sub clause 8.6.1.1.2.

The normative reference for these requirements is TS 25.133 [2] clauses 8.1.2.2 and A.8.1.3.

8.6.1.3.3 Test purpose

To verify that the UE meets the minimum requirements.

8.6.1.3.4 Method of test

8.6.1.3.4.1 Initial conditions

Test environment: normal; see clauses G.2.1 and G.2.2.

Frequencies to be tested: mid range; see clause G.2.4.

The test parameters are given in table 8.6.1.3.1 and 8.6.1.3.2. In the measurement control information it is indicated to the UE that event-triggered reporting with Event 1A and 1B shall be used and the periodical reporting of the events is not applied. The test consists of four successive time periods, with a time duration of T1, T2, T3 and T4 respectively. In the initial condition before the time T1 only Cell1 is active.

Table 8.6.1.3.1: General test parameters for Event triggered reporting of two detectable neighbours in AWGN propagation condition

Parameter	Unit	Value	Comment
DCH parameters		DL and UL Reference Measurement Channel 12.2 kbps	As specified in C.3.1 and C.2.1
Power Control		On	
Active cell		Cell 1	
Reporting range	dB	3	Applicable for event 1A and 1B
Hysteresis	dB	0	
W		1	Applicable for event 1A and 1B
Reporting deactivation threshold		0	Applicable for event 1A
Time to Trigger	ms	0	
Filter coefficient		0	
Monitored cell list size		32	
T1	s	10	
T2	s	10	
T3	s	10	
T4	s	10	

Table 8.6.1.3.2: Cell specific test parameters for Event triggered reporting of two detectable neighbours in AWGN propagation condition

Parameter	Unit	Cell 1				Cell 2				Cell3			
		T1	T2	T3	T4	T1	T2	T3	T4	T1	T2	T3	T4
CPICH_Ec/lor	dB	-10				-10				-10			
PCCPCH_Ec/lor	dB	-12				-12				-12			
SCH_Ec/lor	dB	-12				-12				-12			
PICH_Ec/lor	dB	-15				-15				-15			
DPCH_Ec/lor	dB	-17				N/A				N/A			
OCNS_Ec/lor	dB	-1.049				-0.941				-0.941			
\hat{I}_{or}/I_{oc}	dB	14.5 5	28.5 1	14.4 5	28.5 1	-Inf	27.5 1	13.9 5	21.5 1	8.05	21.5 1	13.9 5	27.5 1
I_{oc}	dBm/ 3.84 MHz	-85											
CPICH_Ec/lo	dB	-11	-13	-14.5	-13	-Inf	-14.0	-15	-20	-17.5	-20	-15	-14
Propagation Condition		AWGN											

8.6.1.3.4.2 Procedure

- 1) The RF parameters are set up according to T1.
- 2) The UE is switched on.
- 3) A call is set up according to the test procedure specified in TS 34.108 [3] sub clause 7.3.2.3.

- 4) SS shall transmit a MEASUREMENT CONTROL message.
- 5) After 10 seconds from the beginning T1, the SS shall switch the power settings from T1 to T2.
- 6) UE shall transmit a MEASUREMENT REPORT message for Cell 2 triggered by event 1A. The measurement reporting delay from the beginning of T2 shall be less than 880 ms. If the UE fails to report the event within the required delay, then a failure is recorded. If the reporting delay for this event is within the required limit, the number of successful tests is increased by one.
- 7) After 10 seconds from the beginning T2, the SS shall switch the power settings from T2 to T3.
- 8) UE shall transmit a MEASUREMENT REPORT message for Cell 3 triggered by event 1A. The measurement reporting delay from the beginning of T3 shall be less than 280 ms. If the UE fails to report the event within the required delay, then a failure is recorded. If the reporting delay for this event is within the required limit, the number of successful tests is increased by one.
- 9) After 10 seconds from the beginning T3, the SS shall switch the power settings from T3 to T4.
- 10) UE shall transmit a MEASUREMENT REPORT message for Cell 2 triggered by event 1B. The measurement reporting delay from the beginning of T4 shall be less than 280 ms. If the reporting delay for this event is within the required limit, the number of successful tests is increased by one.
- 11) After 10 seconds, the UE is switched off.
- 12) Repeat steps 1-11 [50] times.

Specific Message Contents

All messages indicated above shall use the same content as described in the default message content in clause 9 of 34.108 [3], with the following exceptions:

MEASUREMENT CONTROL message:

Information Element/Group name	Value/Remark
Message Type (10.2.17)	
UE information elements	
-RRC transaction identifier	0
-Integrity check info	Not Present
Measurement Information elements	
-Measurement Identity	1
-Measurement Command (10.3.7.46)	Modify
-Measurement Reporting Mode (10.3.7.49)	
-Measurement Report Transfer Mode	AM RLC
-Periodical Reporting / Event Trigger Reporting Mode	Event trigger
-Additional measurements list (10.3.7.1)	Not Present
-CHOICE <i>Measurement type</i>	Intra-frequency measurement
-Intra-frequency measurement (10.3.7.36)	
-Intra-frequency measurement objects list (10.3.7.33)	Not Present
-Intra-frequency measurement quantity (10.3.7.38)	
-Filter coefficient (10.3.7.9)	0
-CHOICE mode	FDD
-Measurement quantity	CPICH_Ec/N0
-Intra-frequency reporting quantity (10.3.7.41)	
-Reporting quantities for active set cells (10.3.7.5)	
-SFN-SFN observed time difference reporting indicator	No report
-Cell synchronisation information reporting indicator	TRUE (Note 1)
-Cell Identity reporting indicator	TRUE
-CHOICE mode	FDD
-CPICH Ec/N0 reporting indicator	TRUE
-CPICH RSCP reporting indicator	TRUE
-Pathloss reporting indicator	TRUE
-Reporting quantities for monitored set cells (10.3.7.5)	
-SFN-SFN observed time difference reporting indicator	No report
-Cell synchronisation information reporting indicator	TRUE (Note 1)
-Cell Identity reporting indicator	TRUE
-CHOICE mode	FDD
-CPICH Ec/N0 reporting indicator	TRUE
-CPICH RSCP reporting indicator	TRUE
-Pathloss reporting indicator	TRUE
-Reporting quantities for detected set cells (10.3.7.5)	Not Present
-Reporting cell status (10.3.7.61)	Not Present
-Measurement validity (10.3.7.51)	Not Present
-CHOICE report criteria	Intra-frequency measurement reporting criteria
-Intra-frequency measurement reporting criteria (10.3.7.39)	
-Parameters required for each event	2
-Intra-frequency event identity	Event 1A
-Triggering condition 2	Monitored set cells
-Reporting Range Constant	3 dB
-Cells forbidden to affect Reporting Range	Not Present
-CHOICE mode	FDD
-Primary CPICH info (10.3.6.60)	
-W	1.0
-Hysteresis	0 dB
-Threshold used frequency	Not Present
-Reporting deactivation threshold	0
-Replacement activation threshold	Not Present
-Time to trigger	0 ms
-Amount of reporting	Not present
-Reporting interval	0 ms (Note 2)
-Reporting cell status	Not Present
-Intra-frequency event identity	Event 1B
-Triggering condition 1	Active set cells and monitored set cells
-Reporting Range Constant	3 dB
-Cells forbidden to affect Reporting Range	Not Present
-CHOICE mode	FDD
-Primary CPICH info (10.3.6.60)	
-W	1.0
-Hysteresis	0 dB

Information Element/Group name	Value/Remark
-Threshold used frequency	Not Present
-Reporting deactivation threshold	Not Present
-Replacement activation threshold	Not Present
-Time to trigger	0 ms
-Amount of reporting	Not Present
-Reporting interval	0 ms (Note 2)
-Reporting cell status	Not Present
Physical channel information elements	
-DPCH compressed mode status info (10.3.6.34)	Not Present
NOTE 1: The SFN-CFN observed time difference is calculated from the OFF and Tm parameters contained in the IE "Cell synchronisation information", TS 25.331, clause 10.3.7.6. According to TS 25.331, 8.6.7.7, this IE is included in MEASUREMENT REPORT if IE "Cell synchronisation information reporting indicator" in IE "Cell reporting quantities" TS 25.331, clause 10.3.7.5 is set to TRUE in MEASUREMENT CONTROL.	
NOTE 2: Reporting interval = 0 ms means no periodical reporting.	

MEASUREMENT REPORT message for Intra frequency test cases

This message is common for all intra frequency test cases is described in Annex I.

8.6.1.3.5 Test requirements

For the test to pass, the total number of successful tests shall be at least 90%, with a confidence level of [FFS]% of the cases. The number of successful tests shall be on an event level, i.e. the SS shall check how many events are reported successfully out of the total number of events checked.

NOTE: If the above Test Requirement differs from the Minimum Requirement then the Test Tolerance applied for this test is non-zero. The Test Tolerance for this test is defined in clause F.2 and the explanation of how the Minimum Requirement has been relaxed by the Test Tolerance is given in clause F.4.

8.6.1.4 Correct reporting of neighbours in fading propagation condition

8.6.1.4.1 Definition and applicability

In the event triggered reporting period the measurement reporting delay is defined as the time between any event that will trigger a measurement report until the UE starts to transmit over the Uu interface. This requirement assumes that the measurement report is not delayed by other RRC signalling on the DCCH. This measurement reporting delay excludes a delay uncertainty resulted when inserting the measurement report to the TTI of the uplink DCCH. The delay uncertainty is twice the TTI of the uplink DCCH.

The requirements and this test apply to the FDD UE.

8.6.1.4.2 Minimum requirements

The requirements are the same as in sub clause 8.6.1.1.2.

The normative reference for these requirements is TS 25.133 [2] clauses 8.1.2.2 and A.8.1.4.

8.6.1.4.3 Test purpose

To verify that the UE meets the minimum requirements and also verify that the UE performs sufficient layer 1 filtering of the measurements. The test is performed in fading propagation conditions.

8.6.1.4.4 Method of test

8.6.1.4.4.1 Initial conditions

Test environment: normal; see clauses G.2.1 and G.2.2.

Frequencies to be tested: mid range; see clause G.2.4.

The test parameters are given in table 8.6.1.4.1 and 8.6.1.4.2. In the measurement control information it is indicated to the UE that event-triggered reporting with Event 1A and Event 1B shall be used. The test consists of two successive time periods, each with time duration of T1 and T2 respectively.

The TTI of the uplink DCCCH shall be 20ms.

Table 8.6.1.4.1: General test parameters for correct reporting of neighbours in fading propagation condition

Parameter	Unit	Value	Comment
DCH parameters		DL and UL Reference Measurement Channel 12.2 kbps	As specified in C.3.1 and C.2.1
Power Control		On	
Active cell		Cell 1	
Reporting range	dB	0	Applicable for event 1A and 1B
Hysteresis	dB	0	
W		1	Applicable for event 1A and 1B
Reporting deactivation threshold		0	Applicable for event 1A
Time to Trigger	ms	120	
Filter coefficient		0	
Monitored cell list size		24	Signalled before time T1.
T1	s	200	
T2	s	201	

Table 8.6.1.4.2: Cell specific test parameters for correct reporting of neighbours in fading propagation condition

Parameter	Unit	Cell 1		Cell 2	
		T1	T2	T1	T2
CPICH_Ec/lor	dB	-10		-10	
PCCPCH_Ec/lor	dB	-12		-12	
SCH_Ec/lor	dB	-12		-12	
PICH_Ec/lor	dB	-15		-15	
DPCH_Ec/lor	dB	-17		N/A	
OCNS		-1.049		-0.941	
\hat{I}_{or}/I_{oc}	dB	7.29	3.29	3.29	7.29
I_{oc}	dBm/3.84 MHz	-70			
CPICH_Ec/lo	dB	-12	-16	-16	-12
Propagation Condition	Case 5 as specified in table D.2.2.1				

8.6.1.4.4.2 Procedure

- 1) The RF parameters are set up according to T1.
- 2) The UE is switched on.
- 3) A call is set up in AWGN conditions, according to the test procedure specified in TS 34.108 [3] sub clause 7.3.2.3.
- 4) SS shall transmit a MEASUREMENT CONTROL message.
- 5) 5 seconds after step4 has completed, the fading simulator is switched on, configured with the settings described in the tables above at the beginning of T1.
- 6) UE shall start transmitting MEASUREMENT REPORT messages triggered by event 1A.
- 7) SS shall count the reports. The number of received event 1A reports shall be less than 60. If the SS fails to receive less than 60 event 1A reports, then then a failure is recorded. If the SS receives number of event 1A reports within the required limit, the number of successful tests is increased by one.

- 8) After 200 seconds from the beginning of T1, the SS shall switch the power settings from T1 to T2.
- 9) UE shall start transmitting MEASUREMENT REPORT messages triggered by event 1B.
- 10) During the first 1s of time period T2 no event reports shall be counted.
- 11) After the first 1s SS shall start counting the reports. The number of received event 1B reports shall be less than 60. If the SS receives number of event 1B reports within the required limit, the number of successful tests is increased by one.
- 12) After 201 seconds from the beginning of T2, the UE is switched off.
- 13) Repeat steps 1-12 [50] times.

Specific Message Contents

All messages indicated above shall use the same content as described in the default message content in clause 9 of 34.108 [3], with the following exceptions:

MEASUREMENT CONTROL message:

Information Element/Group name	Value/Remark
Message Type (10.2.17)	
UE information elements	
-RRC transaction identifier	0
-Integrity check info	Not Present
Measurement Information elements	
-Measurement Identity	1
-Measurement Command (10.3.7.46)	Modify
-Measurement Reporting Mode (10.3.7.49)	
-Measurement Report Transfer Mode	AM RLC
-Periodical Reporting / Event Trigger Reporting Mode	Event trigger
-Additional measurements list (10.3.7.1)	Not Present
-CHOICE <i>Measurement type</i>	Intra-frequency measurement
-Intra-frequency measurement (10.3.7.36)	
-Intra-frequency measurement objects list (10.3.7.33)	Not Present
-Intra-frequency measurement quantity (10.3.7.38)	
-Filter coefficient (10.3.7.9)	0
-CHOICE mode	FDD
-Measurement quantity	CPICH_Ec/N0
-Intra-frequency reporting quantity (10.3.7.41)	
-Reporting quantities for active set cells (10.3.7.5)	
-SFN-SFN observed time difference reporting indicator	No report
-Cell synchronisation information reporting indicator	TRUE (Note 1)
-Cell Identity reporting indicator	TRUE
-CHOICE mode	FDD
-CPICH Ec/N0 reporting indicator	TRUE
-CPICH RSCP reporting indicator	TRUE
-Pathloss reporting indicator	TRUE
-Reporting quantities for monitored set cells (10.3.7.5)	
-SFN-SFN observed time difference reporting indicator	No report
-Cell synchronisation information reporting indicator	TRUE (Note 1)
-Cell Identity reporting indicator	TRUE
-CHOICE mode	FDD
-CPICH Ec/N0 reporting indicator	TRUE
-CPICH RSCP reporting indicator	TRUE
-Pathloss reporting indicator	TRUE
-Reporting quantities for detected set cells (10.3.7.5)	Not Present
-Reporting cell status (10.3.7.61)	Not Present
-Measurement validity (10.3.7.51)	Not Present
-CHOICE report criteria	Intra-frequency measurement reporting criteria
-Intra-frequency measurement reporting criteria (10.3.7.39)	
-Parameters required for each event	2
-Intra-frequency event identity	Event 1A
-Triggering condition 2	Active set cells and monitored set cells
-Reporting Range Constant	0 dB
-Cells forbidden to affect Reporting Range	Not Present
-CHOICE mode	FDD
-Primary CPICH info (10.3.6.60)	
-W	1.0
-Hysteresis	0 dB
-Threshold used frequency	Not Present
-Reporting deactivation threshold	0
-Replacement activation threshold	Not Present
-Time to trigger	120 ms
-Amount of reporting	Not present
-Reporting interval	0 ms (Note 2)
-Reporting cell status	Not Present
-Intra-frequency event identity	Event 1B
-Triggering condition 1	Active set cells and monitored set cells
-Reporting Range Constant	0 dB
-Cells forbidden to affect Reporting Range	Not Present
-CHOICE mode	FDD
-Primary CPICH info (10.3.6.60)	
-W	1.0
-Hysteresis	0 dB

Information Element/Group name	Value/Remark
-Threshold used frequency	Not Present
-Reporting deactivation threshold	Not Present
-Replacement activation threshold	Not Present
-Time to trigger	120 ms
-Amount of reporting	Not Present
-Reporting interval	0 ms (Note 2)
-Reporting cell status	Not Present
Physical channel information elements	
-DPCH compressed mode status info (10.3.6.34)	Not Present
Note 1: The SFN-CFN observed time difference is calculated from the OFF and Tm parameters contained in the IE "Cell synchronisation information", TS 25.331, clause 10.3.7.6. According to TS 25.331, 8.6.7.7, this IE is included in MEASUREMENT REPORT if IE "Cell synchronisation information reporting indicator" in IE "Cell reporting quantities" TS 25.331, clause 10.3.7.5 is set to TRUE in MEASUREMENT CONTROL.	
Note 2: Reporting interval = 0 ms means no periodical reporting	

MEASUREMENT REPORT message for Intra frequency test cases

This message is common for all intra frequency test cases is described in Annex I.

8.6.1.4.5 Test requirements

For the test to pass, the total number of successful tests shall be at least 90%, with a confidence level of [FFS]% of the cases. The number of successful tests shall be on an event level, i.e. the SS shall check every time first if the number of the event 1A events is within the required limit, and then, check if the number of the event 1B events is within the required limit.

NOTE: If the above Test Requirement differs from the Minimum Requirement then the Test Tolerance applied for this test is non-zero. The Test Tolerance for this test is defined in clause F.2 and the explanation of how the Minimum Requirement has been relaxed by the Test Tolerance is given in clause F.4.

8.6.2 FDD inter frequency measurements

8.6.2.1 Correct reporting of neighbours in AWGN propagation condition

8.6.2.1.1 Definition and applicability

In the event triggered reporting period the measurement reporting delay is defined as the time between any event that will trigger a measurement report until the UE starts to transmit the measurement report over the Uu interface. This requirement assumes that the measurement report is not delayed by other RRC signalling on the DCCH. This measurement reporting delay excludes a delay uncertainty resulted when inserting the measurement report to the TTI of the uplink DCCH. The delay uncertainty is twice the TTI of the uplink DCCH.

The requirements and this test apply to the FDD UE.

8.6.2.1.2 Minimum requirements

The UE shall be able to identify a new detectable cell belonging to the monitored set within

$$T_{\text{identify_inter}} = \text{Max} \left\{ 5000, T_{\text{basic_identify_FDD,inter}} \cdot \frac{T_{\text{Measurement_Period, Inter}}}{T_{\text{Inter}}} \cdot N_{\text{Freq}} \right\} \text{ms}$$

A cell shall be considered detectable when CPICH Ec/Io ≥ -20 dB, SCH_Ec/Io ≥ -17 dB for at least one channel tap and SCH_Ec/Ior is equally divided between primary synchronisation code and secondary synchronisation code. When L3 filtering is used an additional delay can be expected.

When transmission gaps are scheduled for FDD inter frequency measurements the UE physical layer shall be capable of reporting measurements to higher layers with measurement accuracy as specified in sub-clause 9.1.1 and 9.1.2 of 25.133 with measurement period given by

$$T_{\text{measurement_inter}} = \text{Max} \left\{ T_{\text{Measurement_Period_Inter}}, T_{\text{basic_measurement_FDD_inter}} \cdot \frac{T_{\text{Measurement_Period_Inter}}}{T_{\text{Inter}}} \cdot N_{\text{Freq}} \right\} \text{ms}$$

If the UE does not need compressed mode to perform inter-frequency measurements, the measurement period for inter frequency measurements is 480 ms.

The UE shall be capable of performing CPICH measurements for $X_{\text{basic_measurement_FDD_inter}}$ inter-frequency cells per FDD frequency of the monitored set or the virtual active set, and the UE physical layer shall be capable of reporting measurements to higher layers with the measurement period of $T_{\text{Measurement_Inter}}$.

$$X_{\text{basic_measurement_FDD_inter}} = 6$$

$T_{\text{Measurement_Period_Inter}} = 480$ ms. The period used for calculating the measurement period $T_{\text{measurement_inter}}$ for inter frequency CPICH measurements.

T_{Inter} : This is the minimum time that is available for inter frequency measurements, during the period $T_{\text{Measurement_Period_inter}}$ with an arbitrarily chosen timing. The minimum time per transmission gap is calculated by using the actual idle length within the transmission gap as given in the table 11 of Annex B in TS 25.212 and by assuming 2*0.5 ms for implementation margin and after that taking only full slots into account in the calculation.

$T_{\text{basic_identify_FDD_inter}} = 800$ ms. This is the time period used in the inter frequency equation where the maximum allowed time for the UE to identify a new FDD cell is defined.

$T_{\text{basic_measurement_FDD_inter}} = 50$ ms. This is the time period used in the equation for defining the measurement period for inter frequency CPICH measurements.

N_{Freq} : Number of FDD frequencies indicated in the inter frequency measurement control information.

The event triggered measurement reporting delay, measured without L3 filtering shall be less than $T_{\text{identify_inter}}$ defined in Clause 8.1.2.3.1 of 25.133 When L3 filtering is used an additional delay can be expected.

If a cell has been detectable at least for the time period $T_{\text{identify_inter}}$ and then enters or leaves the reporting range, the event triggered measurement reporting delay shall be less than $T_{\text{Measurement_Period_Inter}}$ provided the timing to that cell has not changed more than +/-32 chips while transmission gap has not been available and the L3 filter has not been used.

The normative reference for these requirements is TS 25.133 [2] clauses 8.1.2.3 and A.8.2.1.

8.6.2.1.3 Test purpose

To verify that the UE meets the minimum requirements.

8.6.2.1.4 Method of test

8.6.2.1.4.1 Initial conditions

Test environment: normal; see clauses G.2.1 and G.2.2.

Frequencies to be tested: mid range; see clause G.2.4.

The initial test parameters are given in table 8.6.2.1.1

Table 8.6.2.1.1: Cell specific initial test parameters for Correct reporting of neighbours in AWGN propagation condition

Parameter	Unit	Cell 1	Cell 2	Cell3
		T0	T0	T0
CPICH_Ec/Ior	dB	-10	-10	-10
PCCPCH_Ec/Ior	dB	-12	-12	-12
SCH_Ec/Ior	dB	-12	-12	-12
PICH_Ec/Ior	dB	-15	-15	-15
DPCH_Ec/Ior	dB	-17	N/A	N/A
OCNS_Ec/Ior	dB	-1.049	-0.941	-0.941
\hat{I}_{or}/I_{oc}	dB	0	-Inf	-Inf
I_{oc}	dBm/3 .84 MHz	-70		
CPICH_Ec/Io	dB	-13	-Inf	-Inf
Propagation Condition	AWGN			

The test consists of two successive time periods, with a time duration T1 and T2. The test parameters are given in tables 8.6.2.1.2 and 8.6.2.1.3 below. In the measurement control information it is indicated to the UE that event-triggered reporting with Event 1A and 2C shall be used. The CPICH Ec/I0 of the best cell on the unused frequency shall be reported together with Event 2C reporting.

Table 8.6.2.1.2: General test parameters for Correct reporting of neighbours in AWGN propagation condition

Parameter	Unit	Value	Comment
DCH parameters		DL and UL Reference Measurement Channel 12.2 kbps	As specified in C.3.1 and C.2.1
Power Control		On	
Compressed mode		C.5.2 set 1	As specified in C.5.
Active cell		Cell 1	
Threshold non used frequency	dB	-18	Absolute Ec/I0 threshold for event 2C
Reporting range	dB	4	Applicable for event 1A
Hysteresis	dB	0	
W		1	Applicable for event 1A
W non-used frequency		1	Applicable for event 2C
Reporting deactivation threshold		0	Applicable for event 1A
Time to Trigger	ms	0	
Filter coefficient		0	
Monitored cell list size		24 on channel 1 16 on channel 2	Measurement control information is sent before the compressed mode pattern starts.
T1	s	10	
T2	s	5	

Table 8.6.2.1.3: Cell Specific parameters for Correct reporting of neighbours in AWGN propagation condition

Parameter	Unit	Cell 1		Cell 2		Cell 3	
		T1	T2	T1	T2	T1	T2
UTRA RF Channel Number		Channel 1		Channel 1		Channel 2	
CPICH_Ec/Ior	dB	-10		-10		-10	
PCCPCH_Ec/Ior	dB	-12		-12		-12	
SCH_Ec/Ior	dB	-12		-12		-12	
PICH_Ec/Ior	dB	-15		-15		-15	
DPCH_Ec/Ior	dB	-17		N/A		N/A	
OCNS		-1.049		-0.941		-0.941	
\hat{I}_{or}/I_{oc}	dB	0	4.39	-Infinity	2.39	-1.8	-1.8
I_{oc}	dBm/3.84 MHz	-70				-70	
CPICH_Ec/Io	dB	-13	-13	-Infinity	-15	-14	-14
Propagation Condition	AWGN						

8.6.2.1.4.2 Procedure

- 1) The RF parameters are set up according to T0.
- 2) The UE is switched on.
- 3) A call is set up according to the test procedure specified in TS 34.108 [3] sub clause 7.3.2.3.
- 4) SS shall transmit a MEASUREMENT CONTROL message (inter frequency).
- 5) SS shall transmit a MEASUREMENT CONTROL message (intra frequency).
- 6) SS shall transmit PHYSICAL CHANNEL RECONFIGURATION message.
- 7) UE shall transmit PHYSICAL CHANNEL RECONFIGURATION COMPLETE message.
- 8) 5 seconds after step7 has completed, the SS shall switch the power settings from T0 to T1.
- 9) UE shall transmit a MEASUREMENT REPORT message (inter frequency) triggered by event 2C. The measurement reporting delay from the beginning of T1 shall be less than 9.08 seconds. If the UE fails to report the event within the required delay, then a failure is recorded. If the reporting delay for this event is within the required limit, the number of successful tests is increased by one.
- 10) After 10 seconds from the beginning of T1, the SS shall switch the power settings from T1 to T2.
- 11) UE shall transmit a MEASUREMENT REPORT message (intra frequency) triggered by event 1A. The measurement reporting delay from the beginning of T2 shall be less than 1036.2 ms. If the reporting delay for this event is within the required limit, the number of successful tests is increased by one.
- 12) After 5 seconds from the beginning of T2, the UE is switched off.
- 13) Repeat steps 1-12 [50] times.

Specific Message Contents

All messages indicated above shall use the same content as described in the default message content in clause 9 of 34.108 [3], with the following exceptions:

PHYSICAL CHANNEL RECONFIGURATION message for Inter frequency measurement:

Information Element	Value/Remark
Message Type	
UE Information Elements -RRC transaction identifier -Integrity check info -Integrity protection mode info -Ciphering mode info -Activation time -New U-RNTI -New C-RNTI -RRC State Indicator -UTRAN DRX cycle length coefficient	0 Not Present Not Present Not Present Not Present Not Present Not Present CELL_DCH Not Present
CN Information Elements -CN Information info	Not Present
UTRAN mobility information elements -URA identity	Not Present
RB information elements -Downlink counter synchronisation info	Not Present
PhyCH information elements -Frequency info	Not Present
Uplink radio resources -Maximum allowed UL TX power	Not Present
Downlink radio resources -CHOICE mode -Downlink PDSCH information -Downlink information common for all radio links -Downlink DPCH info common for all RL -CHOICE mode -DPCH compressed mode info -Transmission gap pattern sequence -TGPSI -TGPS Status Flag -TGCFN -Transmission gap pattern sequence configuration parameters -TGMP -TGPRC -TGSN -TGL1 -TGL2 -TGD -TGPL1 -TGPL2 -RPP -ITP -CHOICE UL/DL mode -Downlink compressed mode method -Uplink compressed mode method -Downlink frame type -DeltaSIR1 -DeltaSIRafter1 -DeltaSIR2 -DeltaSIRafter2 -N Identify abort -T Reconfirm abort -TX Diversity Mode -SSDT information -Default DPCH Offset Value -Downlink information per radio link list - Downlink information for each radio link -Choice mode -Primary CPICH info -Primary scrambling code -PDSCH with SHO DCH Info	FDD Not Present Not Present FDD 1 Activate (Current CFN + (256 – TTI/10msec))mod 256 FDD measurement Not present 4 7 Not Present 0 3 Not Present Mode 0 Mode 0 UL and DL SF/2 SF/2 B 3.0 3.0 Not Present Not Present Not Present Not Present Not Present Not Present Not Present Not Present Not Present FDD 100 Not Present

-PDSCH code mapping	Not Present
-Downlink DPCH info for each RL	
-CHOICE mode	FDD
-Primary CPICH usage for channel estimation	Primary CPICH may be used
-DPCH frame offset	Set to value Default DPCH Offset Value (as currently stored in SS) mod 38400
-Secondary CPICH info	Not Present
-DL channelisation code	
-Secondary scrambling code	Not Present
-Spreading factor	128
-Code number	0
-Scrambling code change	No code change
-TPC combination index	0
-SSDT Cell Identity	Not Present
-Closed loop timing adjustment mode	Not Present
-SCCPCH Information for FACH	Not Present

MEASUREMENT CONTROL message (inter frequency):

Information Element/Group name	Value/Remark
Message Type (10.2.17)	
UE information elements	
-RRC transaction identifier	0
-Integrity check info	Not Present
Measurement Information elements	
-Measurement Identity	2
-Measurement Command (10.3.7.46)	Setup
-Measurement Reporting Mode (10.3.7.49)	AM RLC
-Measurement Report Transfer Mode	Event trigger
-Periodical Reporting / Event Trigger Reporting Mode	Not Present
-Additional measurements list (10.3.7.1)	Not Present
-CHOICE <i>Measurement type</i>	Inter-frequency measurement
-Inter-frequency measurement (10.3.7.16)	
-Inter-frequency measurement objects list (10.3.7.13)	
- CHOICE Inter-frequency cell removal	Not Present
- New Inter frequency cells	
- Inter frequency cell id	0
- Frequency info	
- CHOICE mode	FDD
- UARFCN uplink(Nu)	Not Present
- UARFCN downlink(Nd)	Same frequency as "Channel2" in Table 8.6.2.1.3
- Cell info	
- Cell individual offset	Not Present
- Reference time difference to cell	Not Present
- Read SFN indicator	TRUE
- CHOICE mode	FDD
- Primary CPICH info	
- Primary scrambling code	Set to Primary scrambling code of Cell3
- Primary CPICH Tx Power	Set to Primary CPICH Tx Power of Cell3 described in Table 8.6.2.1.3
- Tx Diversity Indicator	FALSE
- Cell Selection and Re-selection info	Set to Cell Selection and Re-selection info of Cell3
- Cell for measurement	Not Present
-Inter-frequency measurement quantity (10.3.7.18)	
-Intra-frequency reporting criteria	
-Inter-frequency measurement quantity (10.3.7.38)	
-Filter coefficient (10.3.7.9)	0
-CHOICE mode	FDD
-Measurement quantity	CPICH_Ec/N0
-Inter-frequency reporting criteria	
-Filter coefficient (10.3.7.9)	0
-CHOICE mode	FDD
-Measurement quantity for frequency quality estimate	CPICH_Ec/N0
-Inter-frequency reporting quantity (10.3.7.21)	
-UTRA Carrier RSSI	FALSE
-Frequency quality estimate	FALSE
-Non frequency related cell reporting quantities (10.3.7.5)	
-SFN-SFN observed time difference reporting indicator	No report
-Cell synchronisation information reporting indicator	TRUE (Note 1)
-Cell Identity reporting indicator	TRUE
-CHOICE mode	FDD
-CPICH Ec/N0 reporting indicator	TRUE
-CPICH RSCP reporting indicator	TRUE
-Pathloss reporting indicator	TRUE
-Reporting cell status (10.3.7.61)	Not Present
-Measurement validity (10.3.7.51)	Not Present
-CHOICE report criteria	Inter-frequency measurement reporting criteria
-Inter-frequency measurement reporting criteria (10.3.7.19)	
-Parameters required for each event	1
-Inter-frequency event identity	Event 2C
-Threshold used frequency	Not present
-W used frequency	Not present

Information Element/Group name	Value/Remark
-Hysteresis -Time to trigger -Reporting cell status -CHOICE reported cell -Maximum number of reported cells -Parameters required for each non-used frequency -Threshold non used frequency -W non-used frequency	0 dB 0 ms Report all active set cells + cells within monitored set on used frequency 3 -18 dB 1
Physical channel information elements -DPCH compressed mode status info (10.3.6.34)	Not Present
NOTE 1: The SFN-CFN observed time difference is calculated from the OFF and Tm parameters contained in the IE "Cell synchronisation information", TS 25.331, clause 10.3.7.6. According to TS 25.331, 8.6.7.7, this IE is included in MEASUREMENT REPORT if IE "Cell synchronisation information reporting indicator" in IE "Cell reporting quantities" TS 25.331, clause 10.3.7.5 is set to TRUE in MEASUREMENT CONTROL.	

MEASUREMENT CONTROL message (intra frequency):

Information Element/Group name	Value/Remark
Message Type (10.2.17)	
UE information elements -RRC transaction identifier -Integrity check info	0 Not Present
Measurement Information elements -Measurement Identity -Measurement Command (10.3.7.46) -Measurement Reporting Mode (10.3.7.49) -Measurement Report Transfer Mode -Periodical Reporting / Event Trigger Reporting Mode -Additional measurements list (10.3.7.1)	1 Modify AM RLC Event trigger Not Present
-CHOICE <i>Measurement type</i> -Intra-frequency measurement (10.3.7.36) -Intra-frequency measurement objects list (10.3.7.33) -Intra-frequency measurement quantity (10.3.7.38) -Filter coefficient (10.3.7.9) -CHOICE mode -Measurement quantity -Intra-frequency reporting quantity (10.3.7.41)	Intra-frequency measurement Not Present 0 FDD CPICH_Ec/N0
-Reporting quantities for active set cells (10.3.7.5) -SFN-SFN observed time difference reporting indicator -Cell synchronisation information reporting indicator -Cell Identity reporting indicator -CHOICE mode -CPICH Ec/N0 reporting indicator -CPICH RSCP reporting indicator -Pathloss reporting indicator	No report TRUE (Note 1) TRUE FDD TRUE TRUE TRUE
-Reporting quantities for monitored set cells (10.3.7.5) -SFN-SFN observed time difference reporting indicator -Cell synchronisation information reporting indicator -Cell Identity reporting indicator -CHOICE mode -CPICH Ec/N0 reporting indicator -CPICH RSCP reporting indicator -Pathloss reporting indicator	No report TRUE (Note 1) TRUE FDD TRUE TRUE TRUE
-Reporting quantities for detected set cells (10.3.7.5)	Not Present
-Reporting cell status (10.3.7.61) -Measurement validity (10.3.7.51) -CHOICE report criteria -Intra-frequency measurement reporting criteria (10.3.7.39) -Parameters required for each event	Not Present Not Present Intra-frequency measurement reporting criteria 1
-Intra-frequency event identity -Triggering condition 2 -Reporting Range Constant -Cells forbidden to affect Reporting Range -CHOICE mode -Primary CPICH info (10.3.6.60) -W -Hysteresis -Threshold used frequency -Reporting deactivation threshold -Replacement activation threshold -Time to trigger -Amount of reporting -Reporting interval -Reporting cell status	Event 1A Monitored set cells 4 dB Not Present FDD 1.0 0 dB Not Present 0 Not Present 0 ms Not Present 0 ms (Note 2) Not Present
Physical channel information elements -DPCH compressed mode status info (10.3.6.34)	Not Present
Note 1: The SFN-CFN observed time difference is calculated from the OFF and Tm parameters contained in the IE "Cell synchronisation information", TS 25.331, clause 10.3.7.6. According to TS 25.331, 8.6.7.7, this IE is included in MEASUREMENT REPORT if IE "Cell synchronisation information reporting indicator" in IE "Cell reporting quantities" TS 25.331, clause 10.3.7.5 is set to TRUE in MEASUREMENT CONTROL.	
Note 2: Reporting interval = 0 ms means no periodical reporting	

MEASUREMENT REPORT message for Inter frequency test cases

MEASUREMENT REPORT message for Intra frequency test cases

These messages are common for all inter and intra frequency test cases and are described in Annex I.

8.6.2.1.5 Test requirements

For the test to pass, the total number of successful tests shall be at least 90%, with a confidence level of [FFS]% of the cases. The number of successful tests shall be on an event level, i.e. the SS shall check how many events are reported successfully out of the total number of events checked.

NOTE: If the above Test Requirement differs from the Minimum Requirement then the Test Tolerance applied for this test is non-zero. The Test Tolerance for this test is defined in clause F.2 and the explanation of how the Minimum Requirement has been relaxed by the Test Tolerance is given in clause F.4.

8.6.3 TDD measurements

8.6.3.1 Correct reporting of TDD neighbours in AWGN propagation condition

8.6.3.1.1 Definition and applicability

In the event triggered reporting period the measurement reporting delay is defined as the time between any event that will trigger a measurement report until the UE starts to transmit over the Uu interface. This requirement assumes that the measurement report is not delayed by other RRC signalling on the DCCH. This measurement reporting delay excludes a delay uncertainty resulted when inserting the measurement report to the TTI of the uplink DCCH. The delay uncertainty is twice the TTI of the uplink DCCH.

The requirements and this test apply to the combined FDD and TDD UE.

8.6.3.1.2 Minimum requirement

When transmission gaps are scheduled for inter-frequency TDD measurements, the UE shall be able to identify a new detectable inter-frequency TDD cell belonging to the monitored set within

$$T_{\text{identify TDD inter}} = \text{Max} \left\{ 5000, N_{\text{basic identify TDD inter}} \cdot \frac{T_{\text{Measurement Period TDD inter}}}{N_{\text{TDD inter}}} \cdot N_{\text{Freq}} \right\} \text{ms}$$

If the UE does not need compressed mode to perform inter-frequency TDD measurements, the UE shall be able to identify a new detectable inter-frequency TDD cell belonging to the monitored set within 5000 ms.

An inter-frequency TDD cell shall be considered detectable when P-CCPCH Ec/Io ≥ -8 dB and SCH_Ec/Io ≥ -13 dB. When L3 filtering is used an additional delay can be expected.

When transmission gaps are scheduled for inter frequency TDD measurements the UE physical layer shall be capable of reporting measurements to higher layers with a measurement period as given by

$$T_{\text{measurement TDD inter}} = \text{Max} \left\{ T_{\text{Measurement Period TDD inter}}, N_{\text{basic measurement TDD inter}} \cdot \frac{T_{\text{Measurement Period TDD inter}}}{N_{\text{TDD inter}}} \cdot N_{\text{Freq}} \right\} \text{ms}$$

If the UE does not need compressed mode to perform inter-frequency TDD measurements, the measurement period for inter-frequency TDD measurements shall be 480 ms.

The UE shall be capable of performing P-CCPCH RSCP measurements for $X_{\text{basic measurement TDD inter}}$ inter-frequency TDD cells per TDD frequency of the monitored set and the UE physical layer shall be capable of reporting measurements to higher layers with the measurement period of $T_{\text{measurement TDD inter}}$.

where

$X_{\text{basic_measurement_TDD_inter}} = 6$ (cells)

$T_{\text{Measurement_Period_TDD_inter}} = 480$ ms. The time period used for calculating the measurement period $T_{\text{measurement_TDD_inter}}$ for inter frequency P-CCPCH RSCP measurements.

$N_{\text{TDD_inter}}$: This is the smallest resulting integer number of transmission gap patterns in a transmission gap pattern sequence assigned to UE by UTRAN for inter frequency TDD measurements during the time period $T_{\text{Measurement_Period_TDD_inter}}$ with an arbitrarily chosen timing.

$N_{\text{basic_identify_TDD_inter}} = 80$. This is the number of transmission gap patterns in a transmission gap pattern sequence for inter-frequency TDD measurements during the time period used in the inter frequency TDD equation where the maximum allowed time for the UE to identify a new inter frequency TDD cell is defined.

$N_{\text{basic_measurement_TDD_inter}} = 5$. This is the number of transmission gap patterns in a transmission gap pattern sequence for inter-frequency TDD measurements during the time period $T_{\text{Measurement_Period_TDD_inter}}$ with an arbitrarily chosen timing that is used in the inter-frequency TDD equation for defining where the measurement period for inter frequency P-CCPCH RSCP measurements is defined.

N_{Freq} : This is the number of TDD frequencies indicated in the inter frequency measurement control information.

The normative reference for this requirement is TS 25.133 [2] clauses 8.1.2.4 and A.8.3.1

8.6.3.1.3 Test purpose

To verify that the UE meets the minimum requirement.

8.6.3.1.4 Method of test

8.6.3.1.4.1 Initial conditions

Test environment: normal; see clauses G.2.1 and G.2.2.

Frequencies to be tested: mid range; see clause G.2.4.

The test parameters are given in Table 8.6.3.1.1, 8.6.3.1.2 and 8.6.3.1.3. The test consists of 2 successive time periods, with a time duration T_1 and T_2 . Two cells shall be present in the test, cell 1 being the UTRA FDD serving cell and cell 2 being a UTRA TDD neighbour cell on the unused frequency. All cells shall be synchronised, i.e. share the same frame and timeslot timing.

In the measurement control information it is indicated to the UE that event-triggered reporting with Event 2C shall be used. P-CCPCH RSCP of the best cell on the unused frequency shall be reported together with Event 2C reporting. The Measurement control message shall be sent to the UE such that the delay between the end of the last received TTI containing the message and the beginning of T_1 is at least equal to the RRC procedure delay as defined in [9].

The TTI of the uplink DCCH shall be 20 ms.

Table 8.6.3.1.1: General test parameters for Correct reporting of TDD inter-frequency neighbours in AWGN propagation condition

Parameter	Unit	Value	Comment
DCH parameters		DL Reference Measurement Channel 12.2 kbps	As specified in TS 34.121 Annex C
Power Control		On	
Target quality value on DTCH	BLER	0.01	
Compressed mode		A.22 set 3	As specified in TS 34.121 Annex C
Initial conditions	Active cell	Cell 1	FDD cell
	Neighbour cell	Cell 2	TDD cell
Final condition	Active cell	Cell 1	FDD cell
O	dB	0	Cell individual offset. This value shall be used for all cells in the test.
Hysteresis	dB	0	Hysteresis parameter for event 2C
Time to Trigger	ms	0	
Threshold non-used frequency	dBm	-71	Applicable for Event 2C
Filter coefficient		0	
Monitored cell list size		6 FDD neighbours on Channel 1 6 TDD neighbours on Channel 2	
T1	S	15	
T2	S	10	

Table 8.6.3.1.2: Cell 1 specific parameters for Correct reporting of TDD inter-frequency neighbours in AWGN propagation condition

Parameter	Unit	Cell 1
		T1, T2
UTRA RF Channel Number		Channel 1
CPICH_Ec/I _{or}	dB	-10
P-CCPCH_Ec/I _{or}	dB	-12
SCH_Ec/I _{or}	dB	-12
PICH_Ec/I _{or}	dB	-15
DPCH_Ec/I _{or}	dB	Note 1
OCNS_Ec/I _{or}	dB	Note 2
\hat{I}_{or}/I_{oc}	dB	0
I_{oc}	dBm/3.84 MHz	-70
CPICH_Ec/I _o	dB	-13
Propagation Condition		AWGN
Note 1: The DPCH level is controlled by the power control loop		
Note 2: The power of the OCNS channel that is added shall make the total power from the cell to be equal to I _{or} .		

Table 8.6.3.1.3: Cell 2 specific parameters for Correct reporting of TDD inter-frequency neighbours in AWGN propagation condition

Parameter	Unit	Cell 2			
		0		8	
DL timeslot number		T1	T2	T1	T2
UTRA RF Channel Number		Channel 2			
P-CCPCH_Ec/Ior	dB	-3		n.a.	
PICH_Ec/Ior	dB	n.a.		-3	
SCH_Ec/Ior	dB	-9			
SCH_toffset	dB	10			
OCNS_Ec/Ior	dB	-3.12			
P-CCPCH RSCP	dBm	-75	-67	n.a.	n.a.
\hat{I}_{or}/I_{oc}	dB	-2	6	-2	6
I_{oc}	dBm/3,84 MHz	-70			
Propagation Condition		AWGN			
Note that the transmit energy per PN chip for the SCH is averaged over the 256 chip duration when the SCH is present in the time slot.					

8.6.3.1.4.2 Procedure

- 1) The RF parameters are set up according to T1.
- 2) The UE is switched on.
- 3) A call is set up according to the generic set-up procedure specified in TS 34.108 [3] subclause 7.3.2.3.
- 4) SS shall transmit a MEASUREMENT CONTROL message.
- 5) SS shall transmit a PHYSICAL CHANNEL RECONFIGURATION message.
- 6) UE shall transmit a PHYSICAL CHANNEL RECONFIGURATION COMPLETE message
- 7) After 10 seconds from the beginning of T1, the SS shall switch the power settings from T1 to T2.
- 8) UE shall transmit a MEASUREMENT REPORT message triggered by event 2c for cell 2. The measurement reporting delay from the beginning of T2 shall be less than 9.2 s. If the UE fails to report the event within the required delay, then a failure is recorded. If the reporting delay for this event is within the required limit, the number of successful tests is increased by one.
- 9) After 10 seconds from the beginning of T3, the UE is switched off. Any timing information of cell 2 is deleted in the UE.
- 10) Repeat steps 1-9 [TBD] times.

Specific Message Contents

All messages indicated above shall use the same content as described in the default message content in clause 9 of 34.108 [3], with the following exceptions:

MEASUREMENT CONTROL message (step 4):

Information Element/Group name	Value/Remark
Message Type (10.2.17)	
UE information elements	
-RRC transaction identifier	0
-Integrity check info	Not Present
Measurement Information elements	
-Measurement Identity	1
-Measurement Command (10.3.7.46)	Modify
-Measurement Reporting Mode (10.3.7.49)	AM RLC
-Measurement Report Transfer Mode	Event trigger
-Periodical Reporting / Event Trigger Reporting Mode	Not Present
-Additional measurements list (10.3.7.1)	
-CHOICE <i>Measurement type</i>	Inter-frequency measurement
-Inter-frequency measurement (10.3.7.16)	
-Inter-frequency measurement objects list (10.3.7.13)	
-CHOICE <i>inter-frequency cell removal</i>	No inter-frequency cells removed
-New inter-frequency cells	1
-Inter-frequency cell id	1
-Frequency info (10.3.6.36)	
-CHOICE <i>mode</i>	TDD
-UARFCN(Nt)	Same frequency as channel 2 in Table 8.6.2.4.1.2
-Cell info (10.3.7.2)	
-Cell individual offset	Not Present
-Reference time difference to cell	Not Present
-Read SFN indicator	False
-CHOICE <i>mode</i>	TDD
-Primary CCPCH info (10.3.6.57)	
-CHOICE <i>mode</i>	TDD
-CHOICE Sync case	2
-Timeslot	0
-cell parameters ID	Set to cell parameters ID of cell 2
-SCTD indicator	FALSE
-Primary CCPCH Tx power	Set to Primary CCPCH Tx power of cell 2 as described in Table 8.6.2.4.1.2
-Timeslot list	Not Present
-Cell selection and re-selection info	Not Present
-Cell for measurement	Not Present
-Inter-frequency measurement quantity (10.3.7.18)	
-CHOICE <i>reporting criteria</i>	Inter-frequency reporting criteria
-Filter coefficient (10.3.7.9)	0
-CHOICE <i>mode</i>	TDD
-Measurement quantity for frequency quality estimate	Primary CCPCH RSCP
-Inter-frequency reporting quantity (10.3.7.21)	
-UTRA carrier RSSI	
-Frequency quality estimate	
-Non frequency related cell reporting quantities (10.3.7.5)	
-SFN-SFN observed time difference reporting indicator	No report
-Cell synchronisation information reporting indicator	FALSE
-Cell identity reporting indicator	FALSE
-CHOICE <i>mode</i>	TDD
-Timeslot ISCP reporting indicator	FALSE
-Proposed TGSN Reporting required	FALSE
-Primary CCPCH RSCP reporting indicator	TRUE
-Pathloss reporting indicator	FALSE
-Reporting cell status (10.3.7.61)	Not Present
-Measurement validity (10.3.7.51)	Not Present
-CHOICE <i>report criteria</i>	Inter-frequency measurement reporting criteria
-Inter-frequency measurement reporting criteria (10.3.7.19)	
-Parameters required for each event	1
-Intra-frequency event identity	Event 2C
-Threshold used frequency	Not Present
-W Used frequency	Not Present
-Hysteresis	0 dB
-Time to trigger	0 ms

Information Element/Group name	Value/Remark
<ul style="list-style-type: none">-Reporting Cell Status (10.3..61)-CHOICE reported cell -Maximum number of reported cells-Parameters required for each non-used frequenc- Threshold non-used frequency- W non-used frequency	Report cells within active and/or monitored set on used frequency or within virtual active and/or monitored set on non-used frequency 3 -71 1
Physical channel information elements -DPCH compressed mode status info (10.3.6.34)	Not Present

PHYSICAL CHANNEL RECONFIGURATION message (Step 6)

Information Element	Value/Remark
Message Type	
UE Information Elements	
-RRC transaction identifier	0
-Integrity check info	Not Present
-Integrity protection mode info	Not Present
-Ciphering mode info	Not Present
-Activation time	Not Present
-New U-RNTI	Not Present
-New C-RNTI	Not Present
-RRC State Indicator	CELL_DCH
-UTRAN DRX cycle length coefficient	Not Present
CN Information Elements	
-CN Information info	Not Present
UTRAN mobility information elements	
-URA identity	Not Present
RB information elements	
-Downlink counter synchronisation info	Not Present
PhyCH information elements	
-Frequency info	Not Present
Uplink radio resources	
-Maximum allowed UL TX power	Not Present
Downlink radio resources	
-CHOICE mode	FDD
-Downlink PDSCH information	Not Present
-Downlink information common for all radio links	
-Downlink DPCH info common for all RL	Not Present
-CHOICE mode	FDD
-DPCH compressed mode info	
-Transmission gap pattern sequence	
-TGPSI	1
-TGPS Status Flag	Activate
-TGCFN	(Current CFN + (256 – TTI/10msec))mod 256
-Transmission gap pattern sequence configuration parameters	
-TGMP	TDD measurement
-TGPRC	Not present
-TGSN	10
-TGL1	10
-TGL2	Not Present
-TGD	0
-TGPL1	11
-TGPL2	Not Present
-RPP	Mode 0
-ITP	Mode 0
-CHOICE UL/DL mode	UL and DL
-Downlink compressed mode method	SF/2
-Uplink compressed mode method	puncturing
-Downlink frame type	A
-DeltaSIR1	3.0
-DeltaSIRafter1	3.0
-DeltaSIR2	Not Present
-DeltaSIRafter2	Not Present
-N Identify abort	Not Present
-T Reconfirm abort	Not Present
-TX Diversity Mode	Not Present
-SSDT information	Not Present
-Default DPCH Offset Value	Not Present
-Downlink information per radio link list	
- Downlink information for each radio link	
-Choice mode	FDD
-Primary CPICH info	
-Primary scrambling code	100
-PDSCH with SHO DCH Info	Not Present

-PDSCH code mapping	Not Present
-Downlink DPCH info for each RL	
-CHOICE mode	FDD
-Primary CPICH usage for channel estimation	Primary CPICH may be used
-DPCH frame offset	Set to value Default DPCH Offset Value (as currently stored in SS) mod 38400
-Secondary CPICH info	Not Present
-DL channelisation code	
-Secondary scrambling code	Not Present
-Spreading factor	128
-Code number	0
-Scrambling code change	No code change
-TPC combination index	0
-SSDT Cell Identity	Not Present
-Closed loop timing adjustment mode	Not Present
-SCCPCH Information for FACH	Not Present

MEASUREMENT REPORT message (step 8)

Information Element	Value/remark
Message Type (10.2.17)	
Integrity check info	Not Present
Measurement identity	1
Measured Results (10.3.7.44)	
-CHOICE Measurement	Inter-frequency Measured results list
-Inter-frequency measured results	1
-Frequency info	
-CHOICE mode	TDD
-UARFCN(Nt)	Same frequency as channel 2
-UTRA carrier RSSI	Not Present
-Inter-frequency cell measured results	1
-Cell measured results (10.3.7.3)	
-Cell identity	Not Present
-SFN-SFN observed time difference	Not Present
-Cell synchronisation info	Not Present
-CHOICE mode	TDD
-Cell parameters ID	Set to cell parameters ID of Cell 2
-Proposed TGSN	Not Present
-Primary CCPCH RSCP	Checked that this IE is present
-Pathloss	Not Present
-Timeslot list	Not Present
Measured results on RACH	Not Present
Additional measured results	Not Present
Event results (10.3.7.7)	
-CHOICE event result	Inter-frequency measurement event results
-Inter-frequency event identity	2C
-Inter-frequency cells	1
-Frequency Info	
-CHOICE mode	TDD
-UARFCN(Nt)	Same frequency as channel 2
-CHOICE mode	TDD
-Primary CCPCH Info	
-CHOICE mode	TDD
-CHOICE Sync Case	Not Present
-Cell Parameters ID	Set to cell parameters ID of Cell 2
-SCTD Indicator	FALSE

8.6.3.1.5 Test requirements

The UE shall send one Event 2C triggered measurement report for Cell 2 with a measurement reporting delay less than 9.2 s from the beginning of time period T2.

The UE shall not send event triggered measurement reports, as long as the reporting criteria are not fulfilled.

For the test to pass, the total number of successful tests shall be more than 90% with a confidence level of [FFS]% of the cases.

8.6.4 GSM measurements

8.6.4.1 Correct reporting of GSM neighbours in AWGN propagation condition

8.7 Measurements Performance Requirements

Unless explicitly stated:

- Reported measurements shall be within defined range in 90 % of the cases.
- Measurement channel is 12.2 kbps as defined in Annex C, sub-clause C.3.1. This measurement channel is used both in active cell and cells to be measured.
- Physical channels used as defined in Annex E.
- Cell 1 is the active cell.
- Single task reporting.
- Power control is active.

8.7.1 CPICH RSCP

8.7.1.1 Intra frequency measurements accuracy

8.7.1.1.1 Absolute accuracy requirement

8.7.1.1.1.1 Definition and applicability

The absolute accuracy of CPICH RSCP is defined as the CPICH RSCP measured from one cell compared to the actual CPICH RSCP power from same cell.

The requirements and this test apply to all types of UTRA for the FDD UE.

8.7.1.1.1.2 Minimum Requirements

The accuracy requirements in table 8.7.1.1.1 are valid under the following conditions:

- $CPICH_RSCP1|_{dBm} \geq -114$ dBm.

$$- \left(\frac{I_o}{\hat{I}_{or}} \right) \Big|_{in\ dB} - \left(\frac{CPICH - E_c}{I_{or}} \right) \Big|_{in\ dB} \leq 20dB$$

Table 8.7.1.1.1.1: CPICH_RSCP Intra frequency absolute accuracy

Parameter	Unit	Accuracy [dB]		Conditions Io [dBm/3.84 MHz]
		Normal condition	Extreme condition	
CPICH_RSCP	dBm	±6	±9	-94...-70
	dBm	±8	±11	-70...-50

The normative reference for this requirement is TS 25.133 [2] clauses 9.1.1.1.1 and A.9.1.1.2.

8.7.1.1.1.3 Test purpose

The purpose of this test is to verify that the CPICH RSCP absolute measurement accuracy is within the specified limits in clause 8.7.1.1.1.2. This measurement is for handover evaluation, DL open loop power control, UL open loop control and for the calculation of pathloss.

8.7.1.1.1.4 Method of test

8.7.1.1.1.4.1 Initial conditions

Test environment: normal, TL/VL, TL/VH, TH/VL, TH/VH; see clauses G.2.1 and G.2.2.

Frequencies to be tested: mid range; see clause G.2.4.

In this case all cells are on the same frequency. CPICH RSCP intra frequency absolute accuracy requirements are tested by using test parameters in table 8.7.1.1.1.2.

Table 8.7.1.1.1.2: CPICH RSCP Intra frequency test parameters

Parameter	Unit	Test 1		Test 2		Test 3	
		Cell 1	Cell 2	Cell 1	Cell 2	Cell 1	Cell 2
UTRA RF Channel number		Channel 1		Channel 1		Channel 1	
CPICH_Ec/Ior	dB	-10		-10		-10	
PCCPCH_Ec/Ior	dB	-12		-12		-12	
SCH_Ec/Ior	dB	-12		-12		-12	
PICH_Ec/Ior	dB	-15		-15		-15	
DPCH_Ec/Ior	dB	-15	-	-15	-	-15	-
OCNS_Ec/Ior	dB	-1.11	-0.94	-1.11	-0.94	-1.11	-0.94
Ior	dBm/ 3.84 MHz	-75.54		-59.98		-97.52	
Ior/Ioc	dB	4	0	9	0	0	-6.53
CPICH RSCP, Note 1	dBm	-81.5	-85.5	-60.98	-69.88	-107.5	-114.0
Ioc, Note 1	dBm/3.84 MHz	-69		-50		-94	
Propagation condition	-	AWGN		AWGN		AWGN	
NOTE 1: CPICH RSCP and Ioc levels have been calculated from other parameters for information purposes. They are not settable parameters themselves.							
Tests shall be done sequentially. Test 1 shall be done first. After test 1 has been executed test parameters for tests 2 and 3 shall be set within 5 seconds so that UE does not loose the Cell 2 in between the tests.							

- 1) A call is set up according to the test procedure specified in TS 34.108 [3] clause 7.3.2.3. The RF parameters for Test 1 are set up according to table 8.7.1.1.1.2.

8.7.1.1.1.4.2 Procedure

- 1) SS shall transmit MEASUREMENT CONTROL message.
- 2) UE shall transmit periodically MEASUREMENT REPORT messages.
- 3) SS shall check CPICH_RSCP value in MEASUREMENT REPORT messages. CPICH RSCP power of Cell 1 reported by UE is compared to actual CPICH RSCP power for each MEASUREMENT REPORT message.
- 4) SS shall count number of MEASUREMENT REPORT messages transmitted by UE. After 1000 MEASUREMENT REPORT messages have been received from UE, the RF parameters are set up according to table 8.7.1.1.1.2 for Test 2. While RF parameters are being set up, MEASUREMENT REPORT messages from UE are ignored. SS shall wait for additional 1s and ignore the MEASUREMENT REPORT messages during this period. Then, step 3) above is repeated. After further 1000 MEASUREMENT REPORT messages have been received from UE, the RF parameters are set up according to table 8.7.1.1.1.2 for Test 3. While RF parameters are being set up, MEASUREMENT REPORT messages from UE are ignored. SS shall wait for additional 1s and ignore the MEASUREMENT REPORT messages during this period. Then, step 3) above is repeated.
- 5) After further 1000 MEASUREMENT REPORT messages have been received from UE, the SS shall transmit RRC CONNECTION RELEASE message.
- 6) UE shall transmit RRC CONNECTION RELEASE COMPLETE message.

Specific Message Contents

All messages indicated above shall use the same content as described in the default message content in clause 9 of 34.108 [3], with the following exceptions:

MEASUREMENT CONTROL message for Intra frequency measurement (Step 1):

Information Element	Value/Remark
Message Type	
UE information elements	
-RRC transaction identifier	0
-Integrity check info	Not Present
Measurement Information elements	
-Measurement Identity	1
-Measurement Command	Modify
-Measurement Reporting Mode	
- Measurement Report Transfer Mode	Acknowledged mode RLC
- Periodical Reporting / Event Trigger Reporting Mode	Periodical reporting
-Additional measurement list	Not Present
-CHOICE Measurement Type	Intra-frequency measurement
-Intra-frequency measurement	
- Intra-frequency measurement objects list	Not Present
-Intra-frequency measurement quantity	
-Filter coefficient	0
-CHOICE mode	FDD
-Measurement quantity	CPICH RSCP
-Intra-frequency reporting quantity	
-Reporting quantities for active set cells	
-SFN-SFN observed time difference reporting indicator	No report
-Cell synchronisation information reporting indicator	
-Cell Identity reporting indicator	TRUE
-CHOICE mode	TRUE
-CPICH Ec/N0 reporting indicator	FDD
-CPICH RSCP reporting indicator	TRUE
-Pathloss reporting indicator	TRUE
-Reporting quantities for monitored set cells	
-SFN-SFN observed time difference reporting indicator	No report
-Cell synchronisation information reporting indicator	FALSE
-Cell Identity reporting indicator	TRUE
-CHOICE mode	TRUE
-CPICH Ec/N0 reporting indicator	TRUE
-CPICH RSCP reporting indicator	TRUE
-Pathloss reporting indicator	TRUE
-Reporting quantities for detected set cells	Not Present
-Reporting cell status	
-CHOICE reported cell	Report all active set cells + cells within monitored set on used frequency
-Maximum number of reported cells	Virtual/active set cells + 2
-Measurement validity	Not Present
-CHOICE <i>report criteria</i>	Periodical reporting criteria
-Amount of reporting	Infinity
-Reporting interval	250 ms
Physical channel information elements	
-DPCH compressed mode status info	Not Present

MEASUREMENT REPORT message for Intra frequency test cases

This message is common for all intra frequency test cases in clause 8.7 and is described in Annex I.

8.7.1.1.1.5 Test requirements

The CPICH RSCP measurement accuracy shall meet the requirements in clause 8.7.1.1.1.2.

NOTE: If the above Test Requirement differs from the Minimum Requirement then the Test Tolerance applied for this test is non-zero. The Test Tolerance for this test is defined in clause F.2 and the explanation of how the Minimum Requirement has been relaxed by the Test Tolerance is given in clause F.4.

8.7.1.1.2 Relative accuracy requirement

8.7.1.1.2.1 Definition and applicability

The relative accuracy of CPICH RSCP is defined as the CPICH RSCP measured from one cell compared to the CPICH RSCP measured from another cell on the same frequency.

The requirements and this test apply to all types of UTRA for the FDD UE.

8.7.1.1.2.2 Minimum Requirements

The accuracy requirements in table 8.7.1.1.2.1 are valid under the following conditions:

- $CPICH_RSCP_{1,2}|_{dBm} \geq -114 \text{ dBm}$.
- $\left| CPICH_RSCP1|_{in \text{ dBm}} - CPICH_RSCP2|_{in \text{ dBm}} \right| \leq 20 \text{ dB}$
- $\left(\frac{I_o}{\hat{I}_{or}} \right)|_{in \text{ dB}} - \left(\frac{CPICH - E_c}{I_{or}} \right)|_{in \text{ dB}} \leq 20 \text{ dB}$

Table 8.7.1.1.2.1: CPICH_RSCP Intra frequency relative accuracy

Parameter	Unit	Accuracy [dB]		Conditions
		Normal condition	Extreme condition	Io [dBm/3.84 MHz]
CPICH_RSCP	dBm	±3	±3	-94...-50

The normative reference for this requirement is TS 25.133 [2] clauses 9.1.1.1.2 and A.9.1.1.2.

8.7.1.1.2.3 Test purpose

The purpose of this test is to verify that the CPICH RSCP relative measurement accuracy is within the specified limits in clause 8.7.1.1.2.2. This measurement is for handover evaluation, DL open loop power control, UL open loop control and for the calculation of pathloss.

8.7.1.1.2.4 Method of test

8.7.1.1.2.4.1 Initial conditions

Test environment: normal, TL/VL, TL/VH, TH/VL, TH/VH; see clauses G.2.1 and G.2.2.

Frequencies to be tested: mid range; see clause G.2.4.

In this case all cells are on the same frequency. CPICH RSCP intra frequency relative accuracy requirements are tested by using test parameters in table 8.7.1.1.1.2.

- 1) A call is set up according to the test procedure specified in TS 34.108 [3] clause 7.3.2.3. The RF parameters for Test 1 are set up according to table 8.7.1.1.1.2.

8.7.1.1.2.4.2 Procedure

- 1) SS shall transmit MEASUREMENT CONTROL message.
- 2) UE shall transmit periodically MEASUREMENT REPORT messages.
- 3) SS shall check CPICH_RSCP value of Cell 1 and Cell 2 in MEASUREMENT REPORT messages. CPICH RSCP power value measured from Cell 1 is compared to CPICH RSCP power value measured from Cell 2 for each MEASUREMENT REPORT message.
- 4) The result of step 3) is compared to actual power level difference of CPICH RSCP of Cell 1 and Cell 2.
- 5) SS shall count number of MEASUREMENT REPORT messages transmitted by UE. After 1000 MEASUREMENT REPORT messages have been received from UE, the RF parameters are set up according to table 8.7.1.1.1.2 for Test 2. While RF parameters are being set up, MEASUREMENT REPORT messages from UE are ignored. SS shall wait for additional 1s and ignore the MEASUREMENT REPORT messages during this period. Then, steps 3) and 4) above are repeated. After further 1000 MEASUREMENT REPORT messages have been received from UE, the RF parameters are set up according to table 8.7.1.1.1.2 for Test 3. While RF parameters are being set up, MEASUREMENT REPORT messages from UE are ignored. SS shall wait for additional 1s and ignore the MEASUREMENT REPORT messages during this period. Then, steps 3) and 4) above are repeated.
- 6) After further 1000 MEASUREMENT REPORT messages have been received from UE, the SS shall transmit RRC CONNECTION RELEASE message.
- 7) UE shall transmit RRC CONNECTION RELEASE COMPLETE message.

Specific Message Contents

All messages indicated above shall use the same content as described in the default message content in clause 9 of 34.108 [3], with the following exceptions:

MEASUREMENT CONTROL message for Intra frequency measurement in clause 8.7.1.1.4.2 is used.

MEASUREMENT REPORT message for Intra frequency test cases

This message is common for all intra frequency test cases in clause 8.7 and is described in Annex I.

8.7.1.1.2.5 Test requirements

The CPICH RSCP measurement accuracy shall meet the requirements in clause 8.7.1.1.2.2.

NOTE: If the above Test Requirement differs from the Minimum Requirement then the Test Tolerance applied for this test is non-zero. The Test Tolerance for this test is defined in clause F.2 and the explanation of how the Minimum Requirement has been relaxed by the Test Tolerance is given in clause F.4.

8.7.1.2 Inter frequency measurement accuracy

8.7.1.2.1 Relative accuracy requirement

8.7.1.2.1.1 Definition and applicability

The relative accuracy of CPICH RSCP in inter frequency case is defined as the CPICH RSCP measured from one cell compared to the CPICH RSCP measured from another cell on a different frequency.

The requirements and this test apply to all types of UTRA for the FDD UE.

8.7.1.2.1.2 Minimum Requirements

The accuracy requirements in table 8.7.1.2.1.1 are valid under the following conditions:

- $CPICH_RSCP_{1,2}|_{dBm} \geq -114 \text{ dBm}$.
- $\left| CPICH_RSCP1|_{in \text{ dBm}} - CPICH_RSCP2|_{in \text{ dBm}} \right| \leq 20 \text{ dB}$.
- $| \text{Channel 1_Io}|_{dBm/3.84 \text{ MHz}} - \text{Channel 2_Io}|_{dBm/3.84 \text{ MHz}} | \leq 20 \text{ dB}$.
- $\left(\frac{I_o}{\hat{I}_{or}} \right)|_{in \text{ dB}} - \left(\frac{CPICH_E_c}{I_{or}} \right)|_{in \text{ dB}} \leq 20 \text{ dB}$.

Table 8.7.1.2.1.1: CPICH_RSCP Inter frequency relative accuracy

Parameter	Unit	Accuracy [dB]		Conditions Io [dBm/3.84 MHz]
		Normal condition	Extreme condition	
CPICH_RSCP	dBm	±6	±6	-94...-50

The normative reference for this requirement is TS 25.133 [2] clauses 9.1.1.2.1 and A.9.1.1.2.

8.7.1.2.1.3 Test purpose

The purpose of this test is to verify that the CPICH RSCP relative measurement accuracy is within the specified limits in clause 8.7.1.2.1.2. This measurement is for handover evaluation, DL open loop power control, UL open loop control and for the calculation of pathloss.

8.7.1.2.1.4 Method of test

8.7.1.2.1.4.1 Initial conditions

Test environment: normal, TL/VL, TL/VH, TH/VL, TH/VH; see clauses G.2.1 and G.2.2.

Frequencies to be tested: mid range; see clause G.2.4.

In this case both cells are on different frequencies and compressed mode is applied. The gap length is 7, detailed definition is in clause C.5, set 1 of table C.5.2 except for TGRRC and TGCFN. TGPRC and TGCFN shall set to "Infinity" and "(Current CFN + (256 - TTI/10msec))mod 256". CPICH RSCP inter frequency relative accuracy requirements are tested by using test parameters in table 8.7.1.2.1.2.

Table 8.7.1.2.1.2: CPICH RSCP Inter frequency tests parameters

Parameter	Unit	Test 1		Test 2	
		Cell 1 Channel 1	Cell 2 Channel 2	Cell 1 Channel 1	Cell 2 Channel 2
UTRA RF Channel number					
CPICH_Ec/Ior	dB	-10		-10	
PCCPCH_Ec/Ior	dB	-12		-12	
SCH_Ec/Ior	dB	-12		-12	
PICH_Ec/Ior	dB	-15		-15	
DPCH_Ec/Ior	dB	-15	-	-15	-
OCNS_Ec/Ior	dB	-1.11	-0.94	-1.11	-0.94
Ioc	dBm/ 3.84 MHz	-60.00	-60.00	-84.00	-94.46
Ior/Ioc	dB	9.54	9.54	0	-9.54
CPICH RSCP, Note 1	dBm	-60.46	-60.46	-94.0	-114.0
Io, Note 1	dBm/3.84 MHz	-50.00	-50.00	-81.0	-94.0
Propagation condition	-	AWGN		AWGN	
NOTE 1: CPICH RSCP and Io levels have been calculated from other parameters for information purposes. They are not settable parameters themselves.					
Tests shall be done sequentially. Test 1 shall be done first. After test 1 has been executed test parameters for test 2 shall be set within 5 seconds so that UE does not loose the Cell 2 in between the tests.					

- 1) A call is set up according to the test procedure specified in TS 34.108 [3] clause 7.3.2.3. The RF parameters for Test 1 are set up according to table 8.7.1.2.1.2.

8.7.1.2.1.4.2 Procedure

- 1) SS shall transmit PHYSICAL CHANNEL RECONFIGURATION message.
- 2) UE shall transmit PHYSICAL CHANNEL RECONFIGURATION COMPLETE message.
- 3) SS shall transmit MEASUREMENT CONTROL message for intra frequency measurement and transmit MEASUREMENT CONTROL message for inter frequency measurement.
- 4) UE shall transmit periodically MEASUREMENT REPORT messages.
- 5) SS shall check CPICH_RSCP value of Cell 1 and Cell 2 in MEASUREMENT REPORT messages. CPICH RSCP power value measured from Cell 1 is compared to CPICH RSCP power value measured from Cell 2 for each MEASUREMENT REPORT message.
- 6) The result of step 5) is compared to actual power level difference of CPICH RSCP of Cell 1 and Cell 2.
- 7) SS shall count number of MEASUREMENT REPORT messages transmitted by UE. After 1000 MEASUREMENT REPORT messages have been received from UE, the RF parameters are set up according to table 8.7.1.2.1.2 for Test 2. While RF parameters are being set up, MEASUREMENT REPORT messages from UE are ignored. SS shall wait for additional 1s and ignore the MEASUREMENT REPORT messages during this period. Then, steps 5) and 6) above are repeated.
- 8) After further 1000 MEASUREMENT REPORT messages have been received from UE, the SS shall transmit RRC CONNECTION RELEASE message.
- 9) UE shall transmit RRC CONNECTION RELEASE COMPLETE message.

Specific Message Contents

All messages indicated above shall use the same content as described in the default message content in clause 9 of 34.108 [3], with the following exceptions:

PHYSICAL CHANNEL RECONFIGURATION message for Inter frequency measurement (step 1):

Information Element	Value/Remark
Message Type	
UE Information Elements -RRC transaction identifier -Integrity check info -Integrity protection mode info -Ciphering mode info -Activation time -New U-RNTI -New C-RNTI -RRC State Indicator -UTRAN DRX cycle length coefficient	0 Not Present Not Present Not Present Not Present Not Present Not Present CELL_DCH Not Present
CN Information Elements -CN Information info	Not Present
UTRAN mobility information elements -URA identity	Not Present
RB information elements -Downlink counter synchronisation info	Not Present
PhyCH information elements -Frequency info	Not Present
Uplink radio resources -Maximum allowed UL TX power - CHOICE <i>channel requirement</i>	Not Present Not Present
Downlink radio resources -CHOICE mode -Downlink PDSCH information -Downlink information common for all radio links -Downlink DPCH info common for all RL -CHOICE mode -DPCH compressed mode info -Transmission gap pattern sequence -TGPSI -TGPS Status Flag -TGCFN -Transmission gap pattern sequence configuration parameters -TGMP -TGPRC -TGSN -TGL1 -TGL2 -TGD -TGPL1 -TGPL2 -RPP -ITP -CHOICE UL/DL mode -Downlink compressed mode method -Uplink compressed mode method -Downlink frame type -DeltaSIR1 -DeltaSIRafter1 -DeltaSIR2 -DeltaSIRafter2 -N Identify abort -T Reconfirm abort -TX Diversity Mode -SSDT information -Default DPCH Offset Value -Downlink information per radio link list -Downlink information for each radio link -Choice mode -Primary CPICH info -Primary scrambling code	FDD Not Present Not Present FDD 1 Activate (Current CFN + (256 – TTI/10msec))mod 256 FDD measurement Infinity 4 7 Not Present 0 3 Not Present Mode 0 Mode 0 UL and DL SF/2 SF/2 B 3.0 3.0 Not Present Not Present Not Present Not Present Not Present Not Present Not Present FDD 100

-PDSCH with SHO DCH Info	Not Present
-PDSCH code mapping	Not Present
-Downlink DPCH info for each RL	
-CHOICE mode	FDD
-Primary CPICH usage for channel estimation	Primary CPICH may be used
-DPCH frame offset	Set to value Default DPCH Offset Value (as currently stored in SS) mod 38400
-Secondary CPICH info	Not Present
-DL channelisation code	
-Secondary scrambling code	Not Present
-Spreading factor	128
-Code number	0
-Scrambling code change	No code change
-TPC combination index	0
-SSDT Cell Identity	Not Present
-Closed loop timing adjustment mode	Not Present
-SCCPCH Information for FACH	Not Present

First MEASUREMENT CONTROL message for Intra frequency measurement (Step 3):

Information Element	Value/Remark
Message Type	
UE information elements -RRC transaction identifier -Integrity check info	0 Not Present
Measurement Information elements -Measurement Identity -Measurement Command -Measurement Reporting Mode - Measurement Report Transfer Mode - Periodical Reporting / Event Trigger Reporting Mode -Additional measurement list -CHOICE Measurement Type -Intra-frequency measurement - Intra-frequency measurement objects list -Intra-frequency cell info list -Intra-frequency measurement quantity -Filter coefficient -CHOICE mode -Measurement quantity -Intra-frequency reporting quantity -Reporting quantities for active set cells -SFN-SFN observed time difference reporting indicator -Cell synchronisation information reporting indicator -Cell Identity reporting indicator -CHOICE mode -CPICH Ec/N0 reporting indicator -CPICH RSCP reporting indicator -Pathloss reporting indicator -Reporting quantities for monitored set cells -SFN-SFN observed time difference reporting indicator -Cell synchronisation information reporting indicator -Cell Identity reporting indicator -CHOICE mode -CPICH Ec/N0 reporting indicator -CPICH RSCP reporting indicator -Pathloss reporting indicator -Reporting quantities for detected set cells -Reporting cell status -CHOICE reported cell -Maximum number of reported cells -Measurement validity -CHOICE <i>report criteria</i> -Amount of reporting -Reporting interval	1 Modify Acknowledged mode RLC Periodical reporting Not Present Intra-frequency measurement Not Present 0 FDD CPICH RSCP No report TRUE TRUE FDD TRUE TRUE TRUE No report FALSE TRUE FALSE TRUE TRUE TRUE TRUE Not Present Report all active set cells + cells within monitored set on used frequency Virtual/active set cells + 2 Not Present Periodical reporting criteria Infinity 250 ms
Physical channel information elements -DPCH compressed mode status info	Not Present

Second MEASUREMENT CONTROL message for Inter frequency measurement (step 3):

Information Element	Value/Remark
Message Type	
UE information elements -RRC transaction identifier -Integrity check info	0 Not Present
Measurement Information elements -Measurement Identity -Measurement Command -Measurement Reporting Mode - Measurement Report Transfer Mode - Periodical Reporting / Event Trigger Reporting Mode -Additional measurement list -CHOICE Measurement Type -Inter-frequency measurement object list -CHOICE Inter-frequency cell removal -New inter-frequency cells -Cell for measurement -Inter-frequency measurement quantity -CHOICE reporting criteria -Filter coefficient -CHOICE mode -Measurement quantity for frequency quality estimate -Inter-frequency reporting quantity -UTRA Carrier RSSI -Frequency quality estimate -Non frequency related cell reporting quantities -SFN-SFN observed time difference reporting indicator -Cell synchronisation information reporting indicator -Cell Identity reporting indicator -CHOICE mode -CPICH Ec/N0 reporting indicator -CPICH RSCP reporting indicator -Pathloss reporting indicator -Reporting cell status -CHOICE reported cell -Maximum number of reported cells -Measurement validity -Inter-frequency set update -CHOICE report criteria -Amount of reporting -Reporting interval	2 Setup Acknowledged mode RLC Periodical reporting Not Present Inter-frequency measurement Not Present Cell 2 information is included Not Present Inter-frequency reporting criteria 0 FDD CPICH RSCP TRUE TRUE No report TRUE TRUE FDD TRUE TRUE TRUE Report all active set cells + cells within monitored set on used frequency Virtual/active set cells + 2 Not Present Not Present Periodical reporting criteria Infinity 500 ms
Physical channel information elements -DPCH compressed mode status info	Not Present

MEASUREMENT REPORT message for Inter frequency test cases

This message is common for all inter frequency test cases in clause 8.7 and is described in Annex I.

8.7.1.2.1.5 Test requirements

The CPICH RSCP measurement accuracy shall meet the requirements in clause 8.7.1.2.1.2.

NOTE: If the above Test Requirement differs from the Minimum Requirement then the Test Tolerance applied for this test is non-zero. The Test Tolerance for this test is defined in clause F.2 and the explanation of how the Minimum Requirement has been relaxed by the Test Tolerance is given in clause F.4.

8.7.2 CPICH Ec/Io

8.7.2.1 Intra frequency measurements accuracy

8.7.2.1.1 Absolute accuracy requirement

8.7.2.1.1.1 Definition and applicability

The absolute accuracy of CPICH Ec/Io is defined as the CPICH Ec/Io measured from one cell compared to the actual CPICH_Ec/Io power ratio from same cell.

The requirements and this test apply to all types of UTRA for the FDD UE.

8.7.2.1.1.2 Minimum Requirements

The accuracy requirements in table 8.7.2.1.1.1 are valid under the following conditions:

- CPICH_RSCP1_{dBm} ≥ -114 dBm.

$$- \left(\frac{I_o}{\hat{I}_{or}} \right)_{in \text{ dB}} - \left(\frac{CPICH - E_c}{I_{or}} \right)_{in \text{ dB}} \leq 20dB .$$

Table 8.7.2.1.1.1: CPICH_Ec/Io Intra frequency absolute accuracy, minimum requirements

Parameter	Unit	Accuracy [dB]		Conditions
		Normal condition	Extreme condition	Io [dBm/3.84 MHz]
CPICH_Ec/Io	dB	±1,5 for -14 ≤ CPICH Ec/Io ±2 for -16 ≤ CPICH Ec/Io < -14 ±3 for -20 ≤ CPICH Ec/Io < -16	±3	-94...-50

The normative reference for this requirement is TS 25.133 [2] clause 9.1.2.1.1.

8.7.2.1.1.3 Test purpose

The purpose of this test is to verify that the CPICH Ec/Io absolute measurement accuracy is within the specified limits in clause 8.7.2.1.1.2. This measurement is for Cell selection/re-selection and for handover evaluation.

8.7.2.1.1.4 Method of test

8.7.2.1.1.4.1 Initial conditions

Test environment: normal, TL/VL, TL/VH, TH/VL, TH/VH; see clauses G.2.1 and G.2.2.

Frequencies to be tested: mid range; see clause G.2.4.

In this case all cells are on the same frequency. CPICH Ec/Io intra frequency absolute accuracy requirements are tested by using the test parameters in table 8.7.2.1.1.2.

Parameter	Unit	Test 1		Test 2		Test 3	
		Cell 1	Cell 2	Cell 1	Cell 2	Cell 1	Cell 2
UTRA RF Channel number		Channel 1		Channel 1		Channel 1	
CPICH_Ec/Ior	dB	-10		-10		-10	
PCCPCH_Ec/Ior	dB	-12		-12		-12	
SCH_Ec/Ior	dB	-12		-12		-12	
PICH_Ec/Ior	dB	-15		-15		-15	
DPCH_Ec/Ior	dB	-15	-	-15	-	-6	-
OCNS_Ec/Ior	dB	-1.11	-0.94	-1.11	-0.94	.2.56	-0.94
Ior	dBm/ 3.84 MHz	-56.98		-89.07		-94.98	
Ior/Ior	dB	3.0	3.0	-2.9	-2.9	-9.0	-9.0
CPICH Ec/Io, Note 1	dBm	-14.0	-14.0	-16.0	-16.0	-20.0	-20.0
Io, Note 1	dBm/3.84 MHz	-50		-86		-94	
Propagation condition	-	AWGN		AWGN		AWGN	
NOTE 1: CPICH Ec/Io and Io levels have been calculated from other parameters for information purposes. They are not settable parameters themselves.							
Tests shall be done sequentially. Test 1 shall be done first. After test 1 has been executed test parameters for tests 2 and 3 shall be set within 5 seconds so that UE does not loose the Cell 2 in between the tests.							

- 1) A call is set up according to the test procedure specified in TS 34.108 [3] subclause 7.3.2.3. The RF parameters for Test 1 are set up according to table 8.7.2.1.1.2.

8.7.2.1.1.4.2 Procedure

- 1) SS shall transmit MEASUREMENT CONTROL message.
- 2) UE shall transmit periodically MEASUREMENT REPORT messages.
- 3) SS shall check CPICH_Ec/No value in MEASUREMENT REPORT messages. According to table 8.7.2.1.1.3 the SS calculates CPICH_Ec/Io power ratio of Cell 1, which is compared to the actual CPICH Ec/Io power ratio from the same cell for each MEASUREMENT REPORT message.
- 4) SS shall count number of MEASUREMENT REPORT messages transmitted by UE. After 1000 MEASUREMENT REPORT messages have been received from UE, the RF parameters are set up according to table 8.7.2.1.1.2 for Test 2. While RF parameters are being set up, MEASUREMENT REPORT messages from UE are ignored. SS shall wait for additional 1s and ignore the MEASUREMENT REPORT messages during this period. Then, step 3) above is repeated. After further 1000 MEASUREMENT REPORT messages have been received from UE, the RF parameters are set up according to table 8.7.2.1.1.2 for Test 3. While RF parameters are being set up, MEASUREMENT REPORT messages from UE are ignored. SS shall wait for additional 1s and ignore the MEASUREMENT REPORT messages during this period. Then, step 3) above is repeated.
- 5) After further 1000 MEASUREMENT REPORT messages have been received from UE, the SS shall transmit RRC CONNECTION RELEASE message.
- 6) UE shall transmit RRC CONNECTION RELEASE COMPLETE message.

Table 8.7.2.1.1.3: CPICH Ec/Io measurement report mapping

Reported value	Measured quantity value	Unit
CPICH_Ec/No_00	CPICH Ec/Io < -24	dB
CPICH_Ec/No_01	-24 ≤ CPICH Ec/Io < -23.5	dB
CPICH_Ec/No_02	-23.5 ≤ CPICH Ec/Io < -23	dB
...
CPICH_Ec/No_47	-1 ≤ CPICH Ec/Io < -0.5	dB
CPICH_Ec/No_48	-0.5 ≤ CPICH Ec/Io < 0	dB
CPICH_Ec/No_49	0 ≤ CPICH Ec/Io	dB

Specific Message Contents

All messages indicated above shall use the same content as described in default message content in clause 9 of 34.108 [3], with the following exceptions:

MEASUREMENT CONTROL message for Intra frequency measurement (Step 1):

Information Element	Value/Remark
Message Type	
UE information elements	
-RRC transaction identifier	0
-Integrity check info	Not Present
Measurement Information elements	
-Measurement Identity	1
-Measurement Command	Modify
-Measurement Reporting Mode	Acknowledged mode RLC
- Measurement Report Transfer Mode	Periodical reporting
- Periodical Reporting / Event Trigger Reporting Mode	Not Present
-Additional measurement list	Intra-frequency measurement
-CHOICE Measurement Type	
-Intra-frequency measurement	
- Intra-frequency measurement objects list	Not Present
-Intra-frequency measurement quantity	
-Filter coefficient	0
-CHOICE mode	FDD
-Measurement quantity	CPICH RSCP
-Intra-frequency reporting quantity	
-Reporting quantities for active set cells	
-SFN-SFN observed time difference reporting indicator	No report
-Cell synchronisation information reporting indicator	TRUE
-Cell Identity reporting indicator	TRUE
-CHOICE mode	FDD
-CPICH Ec/N0 reporting indicator	TRUE
-CPICH RSCP reporting indicator	TRUE
-Pathloss reporting indicator	TRUE
-Reporting quantities for monitored set cells	
-SFN-SFN observed time difference reporting indicator	No report
-Cell synchronisation information reporting indicator	FALSE
-Cell Identity reporting indicator	FALSE
-CHOICE mode	FDD
-CPICH Ec/N0 reporting indicator	FALSE
-CPICH RSCP reporting indicator	FALSE
-Pathloss reporting indicator	FALSE
-Reporting quantities for detected set cells	Not Present
-Reporting cell status	
-CHOICE reported cell	Report all active set cells + cells within monitored set on used frequency
-Maximum number of reported cells	Virtual/active set cells + 2
-Measurement validity	Not Present
-CHOICE <i>report criteria</i>	Periodical reporting criteria
-Amount of reporting	Infinity
-Reporting interval	250 ms
Physical channel information elements	
-DPCH compressed mode status info	Not Present

MEASUREMENT REPORT message for Intra frequency test cases

This message is common for all intra frequency test cases in clause 8.7 and is described in Annex I.

8.7.2.1.1.5 Test requirements

The CPICH Ec/Io measurement accuracy shall meet the requirements in clause 8.7.2.1.1.2. The effect of assumed thermal noise and noise generated in the receiver (−99 dBm) shall be added into the required accuracy defined in subclause 8.7.2.1.1.2 as shown in table 8.7.2.1.1.4.

Table 8.7.2.1.1.4: CPICH_Ec/Io Intra frequency absolute accuracy, test requirements

Parameter	Unit	Accuracy [dB]		Conditions
		Normal condition	Extreme condition	Io [dBm/3.84 MHz]
CPICH_Ec/Io	dB	-2.7...1.5 for $-14 \leq \text{CPICH Ec/Io}$ -3.2...2 for $-16 \leq \text{CPICH Ec/Io} < -14$ -4.2...3 for $-20 \leq \text{CPICH Ec/Io} < -16$	-4.2...3	-94...-87
		± 1.5 for $-14 \leq \text{CPICH Ec/Io}$ ± 2 for $-16 \leq \text{CPICH Ec/Io} < -14$ ± 3 for $-20 \leq \text{CPICH Ec/Io} < -16$	± 3	-87...-50

The normative reference for this requirement is TS 25.133 [2] clause A.9.1.2.2.

NOTE: If the above Test Requirement differs from the Minimum Requirement then the Test Tolerance applied for this test is non-zero. The Test Tolerance for this test is defined in clause F.2 and the explanation of how the Minimum Requirement has been relaxed by the Test Tolerance is given in clause F.4.

8.7.2.1.2 Relative accuracy requirement

8.7.2.1.2.1 Definition and applicability

The relative accuracy of CPICH Ec/Io is defined as the CPICH Ec/Io measured from one cell compared to the CPICH Ec/Io measured from another cell on the same frequency.

The requirements and this test apply to all types of UTRA for the FDD UE.

8.7.2.1.2.2 Minimum Requirements

The accuracy requirements in table 8.7.2.1.2.1 are valid under the following conditions:

- $\text{CPICH_RSCP1,2}|_{\text{dBm}} \geq -114 \text{ dBm}$.
- $\left| \text{CPICH_RSCP1}|_{\text{in dBm}} - \text{CPICH_RSCP2}|_{\text{in dBm}} \right| \leq 20 \text{ dB}$.
- $\left| \frac{I_o}{\hat{I}_{or}} \right|_{\text{in dB}} - \left(\frac{\text{CPICH_Ec}}{I_{or}} \right)_{\text{in dB}} \leq 20 \text{ dB}$.

Table 8.7.2.1.2.1: CPICH_Ec/Io Intra frequency relative accuracy

Parameter	Unit	Accuracy [dB]		Conditions
		Normal condition	Extreme condition	Io [dBm/3.84 MHz]
CPICH_Ec/Io	dB	$\pm 1,5$ for $-14 \leq \text{CPICH Ec/Io}$ ± 2 for $-16 \leq \text{CPICH Ec/Io} < -14$ ± 3 for $-20 \leq \text{CPICH Ec/Io} < -16$	± 3	-94...-50

The normative reference for this requirement is TS 25.133 [2] clauses 9.1.2.1.2 and A.9.1.2.2.

8.7.2.1.2.3 Test purpose

The purpose of this test is to verify that the CPICH Ec/Io relative measurement accuracy is within the specified limits in clause 8.7.2.1.2.2. This measurement is for Cell selection/re-selection and for handover evaluation.

8.7.2.1.2.4 Method of test

8.7.2.1.2.4.1 Initial conditions

Test environment: normal, TL/VL, TL/VH, TH/VL, TH/VH; see clauses G.2.1 and G.2.2.

Frequencies to be tested: mid range; see clause G.2.4.

In this case all cells are in the same frequency. CPICH Ec/Io intra frequency relative accuracy requirements are tested by using test parameters in table 8.7.2.1.1.2.

- 1) A call is set up according to the test procedure specified in TS 34.108 [3] subclause 7.3.2.3. The RF parameters for Test 1 are set up according to table 8.7.2.1.1.2.

8.7.2.1.2.4.2 Procedure

- 1) SS shall transmit MEASUREMENT CONTROL message.
- 2) UE shall transmit periodically MEASUREMENT REPORT messages.
- 3) SS shall check CPICH_Ec/No value of Cell 1 and Cell 2 in MEASUREMENT REPORT messages. According to table 8.7.2.1.1.3 the SS calculates CPICH_Ec/Io power ratio of Cell 1 and Cell 2. CPICH_Ec/Io power ratio value measured from Cell 1 is compared to CPICH_Ec/Io power ratio value measured from Cell 2 for each MEASUREMENT REPORT message.
- 4) The result of step 3) is compared to actual power level difference of CPICH_Ec/Io of Cell 1 and Cell 2.
- 5) SS shall count number of MEASUREMENT REPORT messages transmitted by UE. After 1000 MEASUREMENT REPORT messages have been received from UE, the RF parameters are set up according to table 8.7.2.1.1.2 for Test 2. While RF parameters are being set up, MEASUREMENT REPORT messages from UE are ignored. SS shall wait for additional 1s and ignore the MEASUREMENT REPORT messages during this period. Then, steps 3) and 4) above are repeated. After further 1000 MEASUREMENT REPORT messages have been received from UE, the RF parameters are set up according to table 8.7.2.1.1.2 for Test 3. While RF parameters are being set up, MEASUREMENT REPORT messages from UE are ignored. SS shall wait for additional 1s and ignore the MEASUREMENT REPORT messages during this period. Then, steps 3) and 4) above are repeated.
- 6) After further 1000 MEASUREMENT REPORT messages have been received from UE, the SS shall transmit RRC CONNECTION RELEASE message.
- 7) UE shall transmit RRC CONNECTION RELEASE COMPLETE message.

Specific Message Contents

All messages indicated above shall use the same content as described in the default message content in clause 9 of 34.108 [3], with the following exceptions:

MEASUREMENT CONTROL message for Intra frequency measurement in clause 8.7.2.1.1.4.2 is used.

MEASUREMENT REPORT message for Intra frequency test cases

This message is common for all intra frequency test cases in clause 8.7 and is described in Annex I.

8.7.2.1.2.5 Test requirements

The CPICH Ec/Io measurement accuracy shall meet the requirements in clause 8.7.2.1.2.2.

- NOTE: If the above Test Requirement differs from the Minimum Requirement then the Test Tolerance applied for this test is non-zero. The Test Tolerance for this test is defined in clause F.2 and the explanation of how the Minimum Requirement has been relaxed by the Test Tolerance is given in clause F.4.

8.7.2.2 Inter frequency measurement accuracy

8.7.2.2.1 Void

8.7.2.2.2 Relative accuracy requirement

8.7.2.2.2.1 Definition and applicability

The relative accuracy of CPICH Ec/Io in the inter frequency case is defined as the CPICH Ec/Io measured from one cell compared to the CPICH Ec/Io measured from another cell on a different frequency.

The requirements and this test apply to all types of UTRA for the FDD UE.

8.7.2.2.2.2 Minimum Requirements

The accuracy requirements in table 8.7.2.2.2.1 are valid under the following conditions:

- CPICH_RSCP1,2|dBm ≥ -114 dBm.
- $\left| CPICH_RSCP1 \Big|_{in\ dBm} - CPICH_RSCP2 \Big|_{in\ dBm} \right| \leq 20dB$.
- $| Channel\ 1_Io|_{dBm/3.84\ MHz} - Channel\ 2_Io|_{dBm/3.84\ MHz} | \leq 20\ dB$.
- $\left| \frac{I_o}{\hat{I}_{or}} \right|_{in\ dB} - \left(\frac{CPICH_E_c}{I_{or}} \right) \Big|_{in\ dB} \leq 20dB$.

Table 8.7.2.2.2.1: CPICH_Ec/Io Inter frequency relative accuracy, minimum requirements

Parameter	Unit	Accuracy [dB]		Conditions Io [dBm/3.84 MHz]
		Normal condition	Extreme condition	
CPICH_Ec/Io	dB	±1.5 for -14 ≤ CPICH Ec/Io ±2 for -16 ≤ CPICH Ec/Io < -14 ±3 for -20 ≤ CPICH Ec/Io < -16	±3	-94...-50

The normative reference for this requirement is TS 25.133 [2] clauses 9.1.2.2.2 and A.9.1.2.2.

8.7.2.2.2.3 Test purpose

The purpose of this test is to verify that the CPICH Ec/Io relative measurement accuracy is within the specified limits in clause 8.7.2.2.2.2. This measurement is for Cell selection/re-selection and for handover evaluation.

8.7.2.2.2.4 Method of test

8.7.2.2.2.4.1 Initial conditions

Test environment: normal, TL/VL, TL/VH, TH/VL, TH/VH; see clauses G.2.1 and G.2.2.

Frequencies to be tested: mid range; see clause G.2.4.

In this case both cells are in different frequency and compressed mode is applied. The gap length is 7, detailed definition is in clause C.5, set 1 of table C.5.2 except for TGRRC and TGCFN. TGPRC and TGCFN shall set to "Infinity" and "(Current CFN + (256 – TTI/10msec))mod 256". CPICH Ec/Io inter frequency relative accuracy requirements are tested by using test parameters in table 8.7.2.2.2.2.

Table 8.7.2.2.2: CPICH Ec/Io Inter frequency tests parameters

Parameter	Unit	Test 1		Test 2		Test 3	
		Cell 1	Cell 2	Cell 1	Cell 2	Cell 1	Cell 2
UTRA RF Channel number		Channel 1	Channel 2	Channel 1	Channel 2	Channel 1	Channel 2
CPICH_Ec/Ior	dB	-10		-10		-10	
PCCPCH_Ec/Ior	dB	-12		-12		-12	
SCH_Ec/Ior	dB	-12		-12		-12	
PICH_Ec/Ior	dB	-15		-15		-15	
DPCH_Ec/Ior	dB	-15	-	-6	-	-6	-
OCNS_Ec/Ior	dB	-1.11	-0.94	-2.56	-0.94	-2.56	-0.94
Ioc	dBm/ 3.84 MHz	-52.22	-52.22	-87.27	-87.27	-94.46	-94.46
Ior/Ioc	dB	-1.75	-1.75	-4.7	-4.7	-9.54	-9.54
CPICH Ec/Io, Note 1	dBm	-14.0	-14.0	-16.0	-16.0	-20.0	-20.0
Io, Note 1	dBm/3.84 MHz	-50	-50	-86	-86	-94	-94
Propagation condition	-	AWGN		AWGN		AWGN	
NOTE 1: CPICH Ec/Io and Io levels have been calculated from other parameters for information purposes. They are not settable parameters themselves.							
Tests shall be done sequentially. Test 1 shall be done first. After test 1 has been executed test parameters for tests 2 and 3 shall be set within 5 seconds so that UE does not loose the Cell 2 in between the tests.							

- 1) A call is set up according to the test procedure specified in TS 34.108 [3] subclause 7.3.2.3. The RF parameters for Test 1 are set up according to table 8.7.2.2.2.

8.7.2.2.2.4.2 Procedure

- 1) SS shall transmit PHYSICAL CHANNEL RECONFIGURATION message.
- 2) UE shall transmit PHYSICAL CHANNEL RECONFIGURATION COMPLETE message.
- 3) SS shall transmit a MEASUREMENT CONTROL message for intra frequency measurement and transmit another MEASUREMENT CONTROL message for inter frequency measurement.
- 4) UE shall transmit periodically MEASUREMENT REPORT messages.
- 5) SS shall check CPICH_Ec/Io value of Cell 1 and Cell 2 in MEASUREMENT REPORT messages. According to table 8.7.2.1.1.3 the SS calculates CPICH_Ec/Io power ratio of Cell 1 and Cell 2. CPICH_Ec/Io power ratio measured from Cell 1 is compared to CPICH_Ec/Io power value measured from Cell 2 for each MEASUREMENT REPORT message.
- 6) The result of step 5) is compared to actual power level difference of CPICH_Ec/Io of Cell 1 and Cell 2.
- 7) SS shall count number of MEASUREMENT REPORT messages transmitted by UE. After 1000 MEASUREMENT REPORT messages have been received from UE, the RF parameters are set up according to table 8.7.2.2.2 for Test 2. While RF parameters are being set up, MEASUREMENT REPORT messages from UE are ignored. SS shall wait for additional 1s and ignore the MEASUREMENT REPORT messages during this period. Then, steps 5) and 6) above are repeated. After further 1000 MEASUREMENT REPORT messages have been received from UE, the RF parameters are set up according to table 8.7.2.2.2 for Test 3. While RF parameters are being set up, MEASUREMENT REPORT messages from UE are ignored. SS shall wait for additional 1s and ignore the MEASUREMENT REPORT messages during this period. Then, steps 5) and 6) above are repeated.
- 8) After 1000 MEASUREMENT REPORT messages have been received from UE, the SS shall transmit RRC CONNECTION RELEASE message.
- 9) UE shall transmit RRC CONNECTION RELEASE COMPLETE message.

Specific Message Contents

All messages indicated above shall use the same content as described in default message content in clause 9 of 34.108 [3], with the following exceptions:

PHYSICAL CHANNEL RECONFIGURATION message for Inter frequency measurement (step 1):

Information Element	Value/Remark
Message Type	
UE Information Elements -RRC transaction identifier -Integrity check info -Integrity protection mode info -Ciphering mode info -Activation time -New U-RNTI -New C-RNTI -RRC State Indicator -UTRAN DRX cycle length coefficient	0 Not Present Not Present Not Present Not Present Not Present Not Present CELL_DCH Not Present
CN Information Elements -CN Information info	Not Present
UTRAN mobility information elements -URA identity	Not Present
RB information elements -Downlink counter synchronisation info	Not Present
PhyCH information elements -Frequency info	Not Present
Uplink radio resources -Maximum allowed UL TX power - CHOICE <i>channel requirement</i>	Not Present Not Present
Downlink radio resources -CHOICE mode -Downlink PDSCH information -Downlink information common for all radio links -Downlink DPCH info common for all RL -CHOICE mode -DPCH compressed mode info -Transmission gap pattern sequence -TGPSI -TGPS Status Flag -TGCFN -Transmission gap pattern sequence configuration parameters -TGMP -TGPRC -TGSN -TGL1 -TGL2 -TGD -TGPL1 -TGPL2 -RPP -ITP -CHOICE UL/DL mode -Downlink compressed mode method -Uplink compressed mode method -Downlink frame type -DeltaSIR1 -DeltaSIRafter1 -DeltaSIR2 -DeltaSIRafter2 -N Identify abort -T Reconfirm abort -TX Diversity Mode -SSDT information -Default DPCH Offset Value -Downlink information per radio link list -Downlink information for each radio link -Choice mode -Primary CPICH info -Primary scrambling code	FDD Not Present Not Present FDD 1 Activate (Current CFN + (256 – TTI/10msec))mod 256 FDD measurement Infinity 4 7 Not Present 0 3 Not Present Mode 0 Mode 0 UL and DL SF/2 SF/2 B 3.0 3.0 Not Present Not Present Not Present Not Present Not Present Not Present Not Present FDD 100

-PDSCH with SHO DCH Info	Not Present
-PDSCH code mapping	Not Present
-Downlink DPCH info for each RL	
-CHOICE mode	FDD
-Primary CPICH usage for channel estimation	Primary CPICH may be used
-DPCH frame offset	Set to value Default DPCH Offset Value (as currently stored in SS) mod 38400
-Secondary CPICH info	Not Present
-DL channelisation code	
-Secondary scrambling code	Not Present
-Spreading factor	128
-Code number	0
-Scrambling code change	No code change
-TPC combination index	0
-SSDT Cell Identity	Not Present
-Closed loop timing adjustment mode	Not Present
-SCCPCH Information for FACH	Not Present

First MEASUREMENT CONTROL message for Intra frequency measurement (Step 3):

Information Element	Value/Remark
Message Type	
UE information elements -RRC transaction identifier -Integrity check info	0 Not Present
Measurement Information elements -Measurement Identity -Measurement Command -Measurement Reporting Mode - Measurement Report Transfer Mode - Periodical Reporting / Event Trigger Reporting Mode -Additional measurement list -CHOICE Measurement Type -Intra-frequency measurement - Intra-frequency measurement objects list -Intra-frequency cell info list -Intra-frequency measurement quantity -Filter coefficient -CHOICE mode -Measurement quantity -Intra-frequency reporting quantity -Reporting quantities for active set cells -SFN-SFN observed time difference reporting indicator -Cell synchronisation information reporting indicator -Cell Identity reporting indicator -CHOICE mode -CPICH Ec/N0 reporting indicator -CPICH RSCP reporting indicator -Pathloss reporting indicator -Reporting quantities for monitored set cells -SFN-SFN observed time difference reporting indicator -Cell synchronisation information reporting indicator -Cell Identity reporting indicator -CHOICE mode -CPICH Ec/N0 reporting indicator -CPICH RSCP reporting indicator -Pathloss reporting indicator -Reporting quantities for detected set cells -Reporting cell status -CHOICE reported cell -Maximum number of reported cells -Measurement validity -CHOICE <i>report criteria</i> -Amount of reporting -Reporting interval	1 Modify Acknowledged mode RLC Periodical reporting Not Present Intra-frequency measurement Not Present 0 FDD CPICH RSCP No report TRUE TRUE FDD TRUE TRUE TRUE No report FALSE TRUE FDD TRUE TRUE TRUE TRUE Not Present Report all active set cells + cells within monitored set on used frequency Virtual/active set cells + 2 Not Present Periodical reporting criteria Infinity 250 ms
Physical channel information elements -DPCH compressed mode status info	Not Present

Second MEASUREMENT CONTROL message for Inter frequency measurement (step 3):

Information Element	Value/Remark
Message Type	
UE information elements	
-RRC transaction identifier	0
-Integrity check info	Not Present
Measurement Information elements	
-Measurement Identity	2
-Measurement Command	Setup
-Measurement Reporting Mode	
- Measurement Report Transfer Mode	Acknowledged mode RLC
- Periodical Reporting / Event Trigger Reporting Mode	Periodical reporting
-Additional measurement list	Not Present
-CHOICE Measurement Type	Inter-frequency measurement
-Inter-frequency measurement	
-Inter-frequency cell info list	
-CHOICE Inter-frequency cell removal	Not Present
-New inter-frequency cells	Cell 2 information is included
-Cell for measurement	Not Present
-Inter-frequency measurement quantity	
-CHOICE reporting criteria	Inter-frequency reporting criteria
-Filter coefficient	0
-CHOICE mode	FDD
-Measurement quantity for frequency quality estimate	CPICH RSCP
-Inter-frequency reporting quantity	
-UTRA Carrier RSSI	TRUE
-Frequency quality estimate	TRUE
-Non frequency related cell reporting quantities	
-SFN-SFN observed time difference reporting indicator	No report
-Cell synchronisation information reporting indicator	TRUE
-Cell Identity reporting indicator	TRUE
-CHOICE mode	FDD
-CPICH Ec/N0 reporting indicator	TRUE
-CPICH RSCP reporting indicator	TRUE
-Pathloss reporting indicator	TRUE
-Reporting cell status	
-CHOICE reported cell	Report all active set cells + cells within monitored set on used frequency
-Maximum number of reported cells	Virtual/active set cells + 2
-Measurement validity	Not Present
-Inter-frequency set update	Not Present
-CHOICE report criteria	Periodical reporting criteria
-Amount of reporting	Infinity
-Reporting interval	500 ms
Physical channel information elements	
-DPCH compressed mode status info	Not Present

MEASUREMENT REPORT message for Intra frequency test cases

This message is common for all inter frequency test cases in clause 8.7 and is described in Annex I.

8.7.2.2.2.5 Test requirements

The CPICH Ec/Io measurement accuracy shall meet the requirements in clause 8.7.2.2.2.2. The effect of assumed thermal noise and noise generated in the receiver (−99 dBm) shall be added into the required accuracy defined in clause 8.7.2.2.2.2 as shown in table 8.7.2.2.2.3.

Table 8.7.2.2.3: CPICH_Ec/Io Inter frequency relative accuracy, test requirements

Parameter	Unit	Accuracy [dB]		Conditions Io [dBm/3.84 MHz]
		Normal condition	Extreme condition	
CPICH_Ec/Io	dB	-2.7...1.5 for $-14 \leq \text{CPICH Ec/Io}$ -3.2...2 for $-16 \leq \text{CPICH Ec/Io} < -14$ -4.2...3 for $-20 \leq \text{CPICH Ec/Io} < -16$	-4.2...3	-94...-87
		± 1.5 for $-14 \leq \text{CPICH Ec/Io}$ ± 2 for $-16 \leq \text{CPICH Ec/Io} < -14$ ± 3 for $-20 \leq \text{CPICH Ec/Io} < -16$	± 3	-87...-50

The normative reference for this requirement is TS 25.133 [2] clause A.9.1.2.2.

NOTE: If the above Test Requirement differs from the Minimum Requirement then the Test Tolerance applied for this test is non-zero. The Test Tolerance for this test is defined in clause F.2 and the explanation of how the Minimum Requirement has been relaxed by the Test Tolerance is given in clause F.4.

8.7.3 UTRA Carrier RSSI

NOTE: This measurement is for Inter-frequency handover evaluation.

8.7.3.1 Absolute measurement accuracy requirement

8.7.3.1.1 Definition and applicability

The absolute accuracy of UTRA Carrier RSSI is defined as the UTRA Carrier RSSI measured from one frequency compared to the actual UTRA Carrier RSSI power of that same frequency.

The requirements and this test apply to all types of UTRA for the FDD UE.

8.7.3.1.2 Minimum Requirements

Table 8.7.3.1.1: UTRA Carrier RSSI Inter frequency absolute accuracy

Parameter	Unit	Accuracy [dB]		Conditions Io [dBm/3.84 MHz]
		Normal condition	Extreme condition	
UTRA Carrier RSSI	dBm	± 4	± 7	-94...-70
	dBm	± 6	± 9	-70...-50

The normative reference for this requirement is TS 25.133 [2] clause 9.1.3.1.

8.7.3.1.3 Test purpose

The purpose of this test is to verify that the UTRA Carrier RSSI measurement is within the specified limits. This measurement is for inter-frequency handover evaluation.

8.7.3.1.4 Method of test

8.7.3.1.4.1 Initial conditions

Test environment: normal, TL/VL, TL/VH, TH/VL, TH/VH; see clauses G.2.1 and G.2.2.

Frequencies to be tested: mid range; see clause G.2.4.

In this case both cells are on different frequencies and compressed mode is applied. The gap length is 7, detailed definition is in clause C.5, Set 1 of table C.5.2 except for TGRRC and TGCFN. TGPRC and TGCFN shall set to "Infinity" and "(Current CFN + (256 - TTI/10msec))mod 256". UTRA Carrier RSSI absolute accuracy requirements are tested by using test parameters in table 8.7.3.1.2.

Table 8.7.3.1.2: UTRA Carrier RSSI Inter frequency test parameters

Parameter	Unit	Test 1		Test 2		Test 3	
		Cell 1	Cell 2	Cell 1	Cell 2	Cell 1	Cell 2
UTRA RF Channel number		Channel 1	Channel 2	Channel 1	Channel 2	Channel 1	Channel 2
CPICH_Ec/Ior	dB	-10		-10		-10	
PCCPCH_Ec/Ior	dB	-12		-12		-12	
SCH_Ec/Ior	dB	-12		-12		-12	
PICH_Ec/Ior	dB	-15		-15		-15	
DPCH_Ec/Ior	dB	-15	-	-6	-	-6	-
OCNS_Ec/Ior	dB	-1.11	-0.94	-2.56	-0.94	-2.56	-0.94
I _{oc}	dBm/ 3.84 MHz	-52.22	-52.22	-70.27	-70.27	-94.46	-94.46
I _{or/Ioc}	dB	-1.75	-1.75	-4.7	-4.7	-9.54	-9.54
CPICH Ec/Io, Note 1	dBm	-14.0	-14.0	-16.0	-16.0	-20.0	-20.0
I _o , Note 1	dBm/3.84 MHz	-50	-50	-69	-69	-94	-94
Propagation condition	-	AWGN		AWGN		AWGN	
NOTE 1: CPICH Ec/Io and I _o levels have been calculated from other parameters for information purposes. They are not settable parameters themselves.							
Tests shall be done sequentially. Test 1 shall be done first. After test 1 has been executed test parameters for tests 2 and 3 shall be set within 5 seconds so that UE does not loose the Cell 2 in between the tests.							

- 1) A call is set up according to the test procedure specified in TS 34.108 [3] subclause 7.3.2.3. The RF parameters for Test 1 are set up according to table 8.7.3.1.2.

8.7.3.1.4.2 Procedure

- 1) SS shall transmit PHYSICAL CHANNEL RECONFIGURATION message.
- 2) UE shall transmit PHYSICAL CHANNEL RECONFIGURATION COMPLETE message.
- 3) SS shall transmit MEASUREMENT CONTROL message.
- 4) UE shall transmit periodically MEASUREMENT REPORT messages.
- 5) SS shall check UTRA carrier RSSI value of Channel 2 in MEASUREMENT REPORT messages. UTRA carrier RSSI power of Channel 2 reported by UE is compared to actual UTRA Carrier RSSI value of Channel 2 for each MEASUREMENT REPORT message.
- 6) SS shall count number of MEASUREMENT REPORT messages transmitted by UE. After 1000 MEASUREMENT REPORT messages have been received from UE, the RF parameters are set up according to table 8.7.3.1.2 for Test 2. While RF parameters are being set up, MEASUREMENT REPORT messages from UE are ignored. SS shall wait for additional 1s and ignore the MEASUREMENT REPORT messages during this period. Then, step 5) above is repeated. After further 1000 MEASUREMENT REPORT messages have been received from UE, the RF parameters are set up according to table 8.7.3.1.2 for Test 3. While RF parameters are being set up, MEASUREMENT REPORT messages from UE are ignored. SS shall wait for additional 1s and ignore the MEASUREMENT REPORT messages during this period. Then, step 5) above is repeated.
- 7) After further 1000 MEASUREMENT REPORT messages have been received from UE, the SS shall transmit RRC CONNECTION RELEASE message.
- 8) UE shall transmit RRC CONNECTION RELEASE COMPLETE message.

Specific Message Contents

All messages indicated above shall use the same content as described in default message content in clause 9 of 34.108 [3], with the following exceptions:

PHYSICAL CHANNEL RECONFIGURATION message for Inter frequency measurement (step 1):

Information Element	Value/Remark
Message Type	
UE Information Elements -RRC transaction identifier -Integrity check info -Integrity protection mode info -Ciphering mode info -Activation time -New U-RNTI -New C-RNTI -RRC State Indicator -UTRAN DRX cycle length coefficient	0 Not Present Not Present Not Present Not Present Not Present Not Present CELL_DCH Not Present
CN Information Elements -CN Information info	Not Present
UTRAN mobility information elements -URA identity	Not Present
RB information elements -Downlink counter synchronisation info	Not Present
PhyCH information elements -Frequency info	Not Present
Uplink radio resources -Maximum allowed UL TX power - CHOICE <i>channel requirement</i>	Not Present Not Present
Downlink radio resources -CHOICE mode -Downlink PDSCH information -Downlink information common for all radio links -Downlink DPCH info common for all RL -CHOICE mode -DPCH compressed mode info -Transmission gap pattern sequence -TGPSI -TGPS Status Flag -TGCFN -Transmission gap pattern sequence configuration parameters -TGMP -TGPRC -TGSN -TGL1 -TGL2 -TGD -TGPL1 -TGPL2 -RPP -ITP -CHOICE UL/DL mode -Downlink compressed mode method -Uplink compressed mode method -Downlink frame type -DeltaSIR1 -DeltaSIRafter1 -DeltaSIR2 -DeltaSIRafter2 -N Identify abort -T Reconfirm abort -TX Diversity Mode -SSDT information -Default DPCH Offset Value -Downlink information per radio link list -Downlink information for each radio link -Choice mode -Primary CPICH info -Primary scrambling code	FDD Not Present Not Present FDD 1 Activate (Current CFN + (256 – TTI/10msec))mod 256 FDD measurement Infinity 4 7 Not Present 0 3 Not Present Mode 0 Mode 0 UL and DL SF/2 SF/2 B 3.0 3.0 Not Present Not Present Not Present Not Present Not Present Not Present Not Present Not Present FDD 100

-PDSCH with SHO DCH Info	Not Present
-PDSCH code mapping	Not Present
-Downlink DPCH info for each RL	
-CHOICE mode	FDD
-Primary CPICH usage for channel estimation	Primary CPICH may be used
-DPCH frame offset	Set to value Default DPCH Offset Value (as currently stored in SS) mod 38400
-Secondary CPICH info	Not Present
-DL channelisation code	
-Secondary scrambling code	Not Present
-Spreading factor	128
-Code number	0
-Scrambling code change	No code change
-TPC combination index	0
-SSDT Cell Identity	Not Present
-Closed loop timing adjustment mode	Not Present
-SCCPCH Information for FACH	Not Present

MEASUREMENT CONTROL message for Inter frequency measurement (step 3):

Information Element	Value/Remark
Message Type	
UE information elements	
-RRC transaction identifier	0
-Integrity check info	Not Present
Measurement Information elements	
-Measurement Identity	2
-Measurement Command	Setup
-Measurement Reporting Mode	
- Measurement Report Transfer Mode	Acknowledged mode RLC
- Periodical Reporting / Event Trigger Reporting Mode	Periodical reporting
-Additional measurement list	Not Present
-CHOICE Measurement Type	Inter-frequency measurement
-Inter-frequency measurement	
-Inter-frequency cell info list	
-CHOICE Inter-frequency cell removal	Not Present
-New inter-frequency cells	Cell 2 information is included.
-Cell for measurement	Not Present
-Inter-frequency measurement quantity	
-CHOICE reporting criteria	Inter-frequency reporting criteria
-Filter coefficient	0
-CHOICE mode	FDD
-Measurement quantity for frequency quality estimate	CPICH RSCP
-Inter-frequency reporting quantity	
-UTRA Carrier RSSI	TRUE
-Frequency quality estimate	TRUE
-Non frequency related cell reporting quantities	
-SFN-SFN observed time difference reporting indicator	Type 1
-Cell synchronisation information reporting indicator	TRUE
-Cell Identity reporting indicator	TRUE
-CHOICE mode	FDD
-CPICH Ec/N0 reporting indicator	TRUE
-CPICH RSCP reporting indicator	TRUE
-Pathloss reporting indicator	TRUE
-Reporting cell status	
-CHOICE reported cell	Report all active set cells + cells within monitored set on used frequency
-Maximum number of reported cells	Virtual/active set cells + 2
-Measurement validity	Not Present
-Inter-frequency set update	Not Present
-CHOICE report criteria	Periodical reporting criteria
-Amount of reporting	Infinity
-Reporting interval	500 ms
Physical channel information elements	
-DPCH compressed mode status info	Not Present

MEASUREMENT REPORT message for Inter frequency test cases

This message is common for all inter frequency test cases in clause 8.7 and is described in Annex I.

8.7.3.1.5 Test requirements

The UTRA Carrier RSSI absolute measurement accuracy shall meet the requirements in clause 8.7.3.1.2. The effect of assumed thermal noise and noise generated in the receiver (−99 dBm) shall be added into the required accuracy defined in subclause 8.7.3.1.2 as shown in table 8.7.3.1.3.

Table 8.7.3.1.3: UTRA Carrier RSSI absolute accuracy

Parameter	Unit	Accuracy [dB]		Conditions
		Normal condition	Extreme condition	Io [dBm/3.84 MHz]
UTRA Carrier RSSI	dBm	-4...5.2	-7...8.2	-94...-87
	dBm	± 4	± 7	-87...-70
	dBm	± 6	± 9	-70...-50

The normative reference for this requirement is TS 25.133 [2] clause A.9.1.3.2.

NOTE: If the above Test Requirement differs from the Minimum Requirement then the Test Tolerance applied for this test is non-zero. The Test Tolerance for this test is defined in clause F.2 and the explanation of how the Minimum Requirement has been relaxed by the Test Tolerance is given in clause F.4.

8.7.3.2 Relative measurement accuracy requirement

8.7.3.2.1 Definition and applicability

The relative accuracy requirement is defined as the UTRA Carrier RSSI measured from one frequency compared to the UTRA Carrier RSSI measured from another frequency.

The requirements and this test apply to all types of UTRA for the FDD UE.

8.7.3.2.2 Minimum Requirements

The accuracy requirements in table 8.7.3.2.1 are valid under the following condition:

$$| \text{Channel 1}_{\text{Io}}|_{\text{dBm}/3.84 \text{ MHz}} - \text{Channel 2}_{\text{Io}}|_{\text{dBm}/3.84 \text{ MHz}} | < 20 \text{ dB}.$$

Table 8.7.3.2.1: UTRA Carrier RSSI Inter frequency relative accuracy

Parameter	Unit	Accuracy [dB]		Conditions
		Normal condition	Extreme condition	Io [dBm/3.84 MHz]
UTRA Carrier RSSI	dBm	± 7	± 11	-94...-50

The normative reference for this requirement is TS 25.133 [2] clause 9.1.3.2.

8.7.3.2.3 Test purpose

The purpose of this test is to verify that the UTRA Carrier RSSI measurement is within the specified limits. This measurement is for inter-frequency handover evaluation.

8.7.3.2.4 Method of test

8.7.3.2.4.1 Initial conditions

Test environment: normal, TL/VL, TL/VH, TH/VL, TH/VH; see clauses G.2.1 and G.2.2.

Frequencies to be tested: mid range; see clause G.2.4.

In this case both cells are on different frequencies and compressed mode is applied. The gap length is 7, detailed definition is in clause C.5, Set 1 of table C.5.2 except for TGRRC and TGCFN. TGPRC and TGCFN shall set to "Infinity" and "(Current CFN + (256 – TTI/10msec)mod 256)". UTRA Carrier RSSI relative accuracy requirements are tested by using test parameters in table 8.7.3.1.2.

- 1) A call is set up according to the test procedure specified in TS 34.108 [3] clause 7.3.2.3. The RF parameters for Test 1 are set up according to table 8.7.3.1.2.

8.7.3.2.4.2 Procedure

- 1) SS shall transmit PHYSICAL CHANNEL RECONFIGURATION message.
- 2) UE shall transmit PHYSICAL CHANNEL RECONFIGURATION COMPLETE message.
- 3) SS shall transmit MEASUREMENT CONTROL message.
- 4) UE shall transmit periodically MEASUREMENT REPORT messages.
- 5) SS shall check UTRA carrier RSSI value of Channel 1 and Channel 2 in MEASUREMENT REPORT messages. UTRA carrier RSSI power value measured from Channel 1 is compared to UTRA carrier RSSI power value measured from Channel 2 for each MEASUREMENT REPORT message.
- 6) The result of step 5) is compared to actual power level difference of UTRA Carrier RSSI of Channel 1 and Channel 2.
- 7) SS shall count number of MEASUREMENT REPORT messages transmitted by UE. After 1000 MEASUREMENT REPORT messages have been received from UE, the RF parameters are set up according to table 8.7.3.1.2 for Test 2. While RF parameters are being set up, MEASUREMENT REPORT messages from UE are ignored. SS shall wait for additional 1s and ignore the MEASUREMENT REPORT messages during this period. Then, steps 5) and 6) above are repeated. After further 1000 MEASUREMENT REPORT messages have been received from UE, the RF parameters are set up according to table 8.7.3.1.2 for Test 3. While RF parameters are being set up, MEASUREMENT REPORT messages from UE are ignored. SS shall wait for additional 1s and ignore the MEASUREMENT REPORT messages during this period. Then, steps 5) and 6) above are repeated.
- 8) After further 1000 MEASUREMENT REPORT messages have been received from UE, the SS shall transmit RRC CONNECTION RELEASE message.
- 9) UE shall transmit RRC CONNECTION RELEASE COMPLETE message.

Specific Message Contents

All messages indicated above shall use the same content as described in default message content in clause 9 of 34.108 [3], with the following exceptions:

PHYSICAL CHANNEL RECONFIGURATION message and MEASUREMENT CONTROL message for Inter frequency measurement in clause 8.7.3.1.4.2 is used.

MEASUREMENT REPORT message for inter – frequency test cases

This message is common for all inter frequency test cases in clause 8.7 and is described in Annex I.

8.7.3.2.5 Test requirements

The UTRA Carrier RSSI relative measurement accuracy shall meet the requirements in clause 8.7.3.2.2. The effect of assumed thermal noise and noise generated in the receiver (–99 dBm) shall be added into the required accuracy defined in clause 8.7.3.2.2 as shown in table 8.7.3.2.2.

Table 8.7.3.2.2: UTRA Carrier RSSI relative accuracy

Parameter	Unit	Accuracy [dB]		Conditions
		Normal condition	Extreme condition	Io [dBm/3.84 MHz]
UTRA Carrier RSSI	dBm	-4...5.2	-7...8.2	-94...-87
	dBm	± 4	± 7	-87...-70
	dBm	± 6	± 9	-70...-50

The normative reference for this requirement is TS 25.133 [2] clause A.9.1.3.2.

NOTE: If the above Test Requirement differs from the Minimum Requirement then the Test Tolerance applied for this test is non-zero. The Test Tolerance for this test is defined in clause F.2 and the explanation of how the Minimum Requirement has been relaxed by the Test Tolerance is given in clause F.4.

8.7.3A GSM Carrier RSSI

Void.

8.7.3B Transport channel BLER

Void.

8.7.3C UE transmitted power

8.7.3C.1 Definition and applicability

The UE transmitted power absolute accuracy is defined as difference between the UE reported value and the UE transmitted power measured by test system. The reference point for the UE transmitted power shall be the antenna connector of the UE.

The requirements and this test apply to all types of UTRA for the FDD UE.

8.7.3C.2 Minimum requirements

The measurement period in CELL_DCH state is 1 slot.

Table 8.7.3C.2.1 UE transmitted power absolute accuracy

Parameter	Unit	Accuracy [dB]	
		PUEMAX 24dBm	PUEMAX 21dBm
UE transmitted power=PUEMAX	dBm	+1/-3	±2
UE transmitted power=PUEMAX-1	dBm	+1.5/-3.5	±2.5
UE transmitted power=PUEMAX-2	dBm	+2/-4	±3
UE transmitted power=PUEMAX-3	dBm	+2.5/-4.5	±3.5
PUEMAX-10≤UE transmitted power<PUEMAX-3	dBm	+3/-5	±4

NOTE 1: User equipment maximum output power, PUEMAX, is the maximum output power level without tolerance defined for the power class of the UE in TS 25.101 [1] section 6.2.1.

NOTE 2: UE transmitted power is the reported value.

For each empty slot created by compressed mode, no value shall be reported by the UE L1 for those slots.

The normative reference for this requirement is TS 25.133 [2] clause 9.1.6.

8.7.3C.3 Test purpose

The purpose of this test is to verify that for any reported value of UE Transmitted Power in the range PUEMAX to PUEMAX-10 that the actual UE mean power lies within the range specified in clause 8.7.3C.2.

8.7.3C.4 Method of test

8.7.3C.4.1 Initial conditions

Test environment: normal, TL/VL, TL/VH, TH/VL, TH/VH; see clauses G.2.1 and G.2.2.

Frequencies to be tested: mid range; see clause G.2.4.

- 1) Connect SS to the UE antenna connector as shown in figure A.1.

The test parameters are given in Table 8.7.3C.4.1 and 8.7.3C.4.2 below. In the measurement control information it shall be indicated to the UE that periodic reporting of the UE transmitted power measurement shall be used.

Table 8.7.3C.4.1: General test parameters for UE transmitted power

Parameter	Unit	Value	Comment
DCH parameters		DL Reference Measurement Channel 12.2 kbps	As specified in clause C.3.1
Power Control		On	
Target quality value on DTCH	BLER	0.01	

Table 8.7.3C.4.2: Cell Specific parameters for UE transmitted power

Parameter	Unit	Cell 1
CPICH_Ec/I _{or}	dB	-10
PCCPCH_Ec/I _{or}	dB	-12
SCH_Ec/I _{or}	dB	-12
PICH_Ec/I _{or}	dB	-15
DPCH_Ec/I _{or}	dB	Note 1
OCNS		Note 2
\hat{I}_{or}/I_{oc}	dB	0
I_{oc}	dBm/3.84 MHz	-70
CPICH_Ec/I _o	dB	-13
Propagation Condition		AWGN
Note 1: The DPCH level is controlled by the power control loop		
Note 2: The power of the OCNS channel that is added shall make the total power from the cell to be equal to I _{or} .		

8.7.3C.4.2 Procedure

- 1) A call is set up according to the test procedure specified in TS 34.108 [3] subclause 7.3.2.3. The RF parameters are set up according to table 8.7.3C.4.1 and 8.7.3C.4.2. Set the UE power and Maximum allowed UL TX power to the maximum power for the UE power class.
- 2) SS shall send continuously during the entire test Up power control commands to the UE.
- 3) SS shall transmit the MEASUREMENT CONTROL message as defined in the specific message contents below.
- 4) Decode the UE Transmitted power reported by the UE in the next available MEASUREMENT REPORT message.
- 5) Measure the mean power of the UE over a period of one timeslot.
- 6) Steps 4 and 5 shall be repeated [100] times.
- 7) Decrease the Maximum allowed UL TX power by 1 dB. The SS shall transmit the PHYSICAL CHANNEL RECONFIGURATION message, as defined in the specific message contents below.
- 8) SS shall wait for the PHYSICAL CHANNEL RECONFIGURATION COMPLETE message from the UE.
- 9) Repeat from step 4) until the Maximum allowed UL TX Power reaches PUEMAX-11.

Specific Message Contents

All messages indicated above shall use the same content as described in default message content in clause 9 of 34.108 [3], with the following exceptions:

MEASUREMENT CONTROL message:

Information Element	Value/Remark
Message Type	
UE information elements -RRC transaction identifier -Integrity check info	0 Not Present
Measurement Information elements -Measurement Identity -Measurement Command -CHOICE Measurement type -UE Internal measurement quantity -CHOICE mode -Measurement quantity -Filter coefficient -UE Internal reporting quantity -UE Transmitted power -CHOICE mode -UE Rx-Tx time difference -CHOICE report criteria -Amount of reporting -Reporting interval -Measurement Reporting Mode -Measurement Report Transfer Mode -Periodical Reporting / Event Trigger Reporting Mode	1 Modify UE Internal measurement FDD UE Transmitted power 0 TRUE FDD FALSE Periodical reporting criteria Infinity 250 AM RLC Periodical reporting
Physical channel information elements -DPCH compressed mode status info	Not Present

MEASUREMENT REPORT message:

Information Element	Value/remark
Message Type	
Integrity check info	The presence of this IE is dependent on IXIT statements in TS 34.123-2. If integrity protection is indicated to be active, this IE shall be present with the values of the sub IEs as stated below. Else, this IE and the sub-IEs shall be absent.
- Message authentication code	This IE is checked to see if it is present. The value is compared against the XMAC-I value computed by SS.
- RRC Message sequence number	This IE is checked to see if it is present. The value is used by SS to compute the XMAC-I value.
Measurement identity	1
Measured Results	
- Intra-frequency measured results	
- Cell measured results	
- Cell Identity	Not present
- SFN-SFN observed time difference	Checked that this IE is absent
- Cell synchronisation information	Checked that this IE is absent
- Primary CPICH info	
- Primary scrambling code	150
- CPICH Ec/NO	Checked that this IE is absent
- CPICH RSCP	Checked that this IE is present
- Pathloss	Checked that this IE is absent
Measured results on RACH	Checked that this IE is absent
Additional measured results	
- UE internal measured results	
- Choice mode	FDD
- UE Transmitted power	Checked that this IE is present
- UE Rx-Tx report entries	Checked that this IE is absent
Event results	Checked that this IE is absent

PHYSICAL CHANNEL RECONFIGURATION message:

Information Element	Value/Remark
Message Type	
UE Information Elements	
-RRC transaction identifier	0
-Integrity check info	Not Present
-Integrity protection mode info	Not Present
-Ciphering mode info	Not Present
-Activation time	Not Present
-New U-RNTI	Not Present
-New C-RNTI	Not Present
-RRC State Indicator	CELL_DCH
-UTRAN DRX cycle length coefficient	Not Present
CN Information Elements	
-CN Information info	Not Present
UTRAN mobility information elements	
-URA identity	Not Present
RB information elements	
-Downlink counter synchronisation info	Not Present
PhyCH information elements	
-Frequency info	Not Present
Uplink radio resources	
-Maximum allowed UL TX power	At the first time this value is set to PUEMAX-1. After the second time this value is decreased with 1 dB from previous value.
Downlink radio resources	
-CHOICE mode	FDD
-Downlink PDSCH information	Not Present
-Downlink information common for all radio links	Not Present
-Downlink information per radio link list	Not Present

8.7.3C.5 Test requirements

Compare each of the UE transmitted power reports against the following mean power measurement. At least 90% of the mean power measurements for any one value of reported UE transmitted power shall be within the range specified in table 8.7.3C.5.

NOTE It is not expected or required that the distribution of UE transmitted power reports is even for the 11 possible reported values.

Table 8.7.3C.5 UE transmitted power test requirements

Parameter	Unit	Mean Power range [dB]	
		PUEMAX 24dBm	PUEMAX 21dBm
UE transmitted power=PUEMAX	dBm	+1.7/-3.7	±2.7
UE transmitted power=PUEMAX-1	dBm	+2.2/-4.2	±3.2
UE transmitted power=PUEMAX-2	dBm	+2.7/-4.7	±3.7
UE transmitted power=PUEMAX-3	dBm	+3.2/-5.2	±4.2
UE transmitted power=PUEMAX-4	dBm	+3.7/-5.7	±4.7
UE transmitted power=PUEMAX-5	dBm	+3.7/-5.7	±4.7
UE transmitted power=PUEMAX-6	dBm	+3.7/-5.7	±4.7
UE transmitted power=PUEMAX-7	dBm	+3.7/-5.7	±4.7
UE transmitted power=PUEMAX-8	dBm	+3.7/-5.7	±4.7
UE transmitted power=PUEMAX-9	dBm	+3.7/-5.7	±4.7
UE transmitted power=PUEMAX-10	dBm	+3.7/-5.7	±4.7

NOTE: If the above Test Requirement differs from the Minimum Requirement then the Test Tolerance applied for this test is non-zero. The Test Tolerance for this test is defined in clause F.2 and the explanation of how the Minimum Requirement has been relaxed by the Test Tolerance is given in clause F.4.

8.7.4 SFN-CFN observed time difference

8.7.4.1 Intra frequency measurement requirement

8.7.4.1.1 Definition and applicability

The intra frequency SFN-CFN observed time difference is defined as the SFN-CFN observed time difference from the active cell to a neighbour cell that is in the same frequency. This measurement is specified in clause 5.1.8 of TS 25.215 [22].

The reference point for the SFN-CFN observed time difference shall be the antenna connector of the UE.

The requirements and this test apply to all types of UTRA for the FDD UE.

8.7.4.1.2 Minimum requirements

The accuracy requirement in table 8.7.4.1.1 is valid under the following conditions:

$CPICH_RSCP1,2|_{dBm} \geq -114$ dBm.

$$\left| CPICH_RSCP1|_{in\ dBm} - CPICH_RSCP2|_{in\ dBm} \right| \leq 20dB$$

$$\left(\frac{I_o}{\hat{I}_{or}} \right) |_{in\ dB} - \left(\frac{CPICH_E_c}{I_{or}} \right) |_{in\ dB} \leq 20dB$$

$$\left(\frac{I_o}{\hat{I}_{or}} \right)_{in \text{ dB}} - \left(\frac{P - CCPCH - E_c}{I_{or}} \right)_{in \text{ dB}}$$

is low enough to ensure successful SFN decoding.

Table 8.7.4.1.1

Parameter	Unit	Accuracy [chip]	Conditions
			Io [dBm/3.84 MHz]
SFN-CFN observed time difference	chip	± 1	-94...-50

The normative reference for this requirement is TS 25.133 [2] clauses 9.1.7.1 and A.9.1.4.2.

8.7.4.1.3 Test Purpose

The purpose of this test is to verify that the SFN-CFN observed time difference measurement accuracy is within the specified limits in the clause 8.7.4.1.2. This measurement is for handover timing purposes to identify active cell and neighbour cell time difference.

8.7.4.1.4 Method of test

8.7.4.1.4.1 Initial conditions

Test environment: normal, TL/VL, TL/VH, TH/VL, TH/VH; see clauses G.2.1 and G.2.2.

Frequencies to be tested: mid range; see clause G.2.4.

During the test the timing difference between Cell 1 and 2 can be set to value from 0...9830399 chips.

In this case all cells are in the same frequency. Table 8.7.4.1.2 defines the limits of signal strengths and code powers, where the requirements are applicable.

Table 8.7.4.1.2: SFN-CFN observed time difference Intra frequency test parameters

Parameter	Unit	Test 1		Test 2		Test 3	
		Cell 1	Cell 2	Cell 1	Cell 2	Cell 1	Cell 2
UTRA RF Channel number		Channel 1		Channel 1		Channel 1	
CPICH_Ec/Ior	dB	-10		-10		-10	
PCCPCH_Ec/Ior	dB	-12		-12		-12	
SCH_Ec/Ior	dB	-12		-12		-12	
PICH_Ec/Ior	dB	-15		-15		-15	
DPCH_Ec/Ior	dB	-15		-15		-15	
OCNS_Ec/Ior	dB	-1.11		-1.11		-1.11	
\hat{I}_{or}/I_{oc}	dB	10.5		10.5		10.5	
Ioc	dBm/ 3.84 MHz	<i>I_o -13.7 dB = I_{oc}</i> , Note 1		<i>I_o -13.7 dB = I_{oc}</i> , Note 1		<i>I_o -13.7 dB = I_{oc}</i> , Note 1	
Io	dBm/3.84 MHz	-50		-72		-94	
Relative delay of path received from cell 2 with respect to cell 1	chip	x Note 2					
Propagation condition	-	AWGN		AWGN		AWGN	
NOTE 1: <i>I_{oc}</i> level shall be adjusted according the total signal power <i>I_o</i> at receiver input and the geometry factor \hat{I}_{or}/I_{oc} .							
NOTE2: For example, x= 491520 or 9830399							
Tests shall be done sequentially. Test 1 shall be done first. After test 1 has been executed test parameters for tests 2 and 3 shall be set within 5 seconds so that UE does not loose the Cell 2 in between the tests.							

- 1) A call is set up according to the test procedure specified in TS 34.108 [3] subclause 7.3.2.3. The RF parameters for Test 1 are set up according to table 8.7.4.1.2.

8.7.4.1.4.2 Procedure

- 1) SS shall transmit MEASUREMENT CONTROL message.
- 2) UE shall transmit periodically MEASUREMENT REPORT message.
- 3) SS shall check "OFF" and "Tm" values in MEASUREMENT REPORT message and calculate SFN-CFN observed time difference value according to the definition in clause 5.1.8 of TS 25.215 [22]. This value shall be compared to the actual SFN-CFN observed time difference value for each MEASUREMENT REPORT message.
- 4) SS shall count the number of MEASUREMENT REPORT messages transmitted by UE. After 1000 MEASUREMENT REPORT messages have been received from UE, the RF parameters are set up according to table 8.7.4.1.2 for Test 2. While RF parameters are being set up, MEASUREMENT REPORT messages from UE are ignored. SS shall wait for additional 1s and ignore the MEASUREMENT REPORT messages during this period. Then, step 3) above is repeated. After further 1000 MEASUREMENT REPORT messages have been received from UE, the RF parameters are set up according to table 8.7.4.1.2 for Test 3. While RF parameters are being set up, MEASUREMENT REPORT messages from UE are ignored. SS shall wait for additional 1s and ignore the MEASUREMENT REPORT messages during this period. Then, step 3) above is repeated.
- 5) After further 1000 MEASUREMENT REPORT messages have been received from UE, the SS shall transmit RRC CONNECTION RELEASE message.
- 6) UE shall transmit RRC CONNECTION RELEASE COMPLETE message.

Specific Message Contents

All messages indicated above shall use the same content as described in the default message content in clause 9 of 34.108 [3], with the following exceptions:

MEASUREMENT CONTROL message for intra frequency measurement

Information Element	Value/Remark
Message Type	
UE information elements -RRC transaction identifier -Integrity check info	0 Not Present
Measurement Information elements -Measurement Identity -Measurement Command -Measurement Reporting Mode - Measurement Report Transfer Mode - Periodical Reporting / Event Trigger Reporting Mode -Additional measurement list -CHOICE Measurement Type -Intra-frequency measurement - Intra-frequency measurement objects list -Intra-frequency measurement quantity -Filter coefficient -CHOICE mode -Measurement quantity -Intra-frequency reporting quantity -Reporting quantities for active set cells -SFN-SFN observed time difference reporting indicator -Cell synchronisation information reporting indicator -Cell Identity reporting indicator -CHOICE mode -CPICH Ec/N0 reporting indicator -CPICH RSCP reporting indicator -Pathloss reporting indicator -Reporting quantities for monitored set cells -SFN-SFN observed time difference reporting indicator -Cell synchronisation information reporting indicator -Cell Identity reporting indicator -CHOICE mode -CPICH Ec/N0 reporting indicator -CPICH RSCP reporting indicator -Pathloss reporting indicator -Reporting quantities for detected set cells -Reporting cell status -CHOICE reported cell -Maximum number of reported cells -Measurement validity -CHOICE <i>report criteria</i> -Amount of reporting -Reporting interval	1 Modify Acknowledged mode RLC Periodical reporting Not Present Intra-frequency measurement Not Present 0 FDD CPICH RSCP No report TRUE TRUE FDD TRUE TRUE TRUE No report TRUE TRUE TRUE TRUE TRUE TRUE TRUE Not Present Report all active set cells + cells within monitored set on used frequency Virtual/active set cells + 2 Not Present Periodical reporting criteria Infinity 250 ms
Physical channel information elements -DPCH compressed mode status info	Not Present

MEASUREMENT REPORT message for Intra frequency test cases

This message is common for all intra frequency test cases in clause 8.7 and is described in Annex I.

8.7.4.1.5 Test requirements

The SFN-CFN observed time difference measurement accuracy shall meet the requirements in clause 8.7.4.1.2.

NOTE: If the above Test Requirement differs from the Minimum Requirement then the Test Tolerance applied for this test is non-zero. The Test Tolerance for this test is defined in clause F.2 and the explanation of how the Minimum Requirement has been relaxed by the Test Tolerance is given in clause F.4.

8.7.4.2 Inter frequency measurement requirement

8.7.4.2.1 Definition and applicability

The inter frequency SFN-CFN observed time difference is defined as the SFN-CFN time difference from the active cell to a neighbour cell that is in a different frequency. This measurement is specified in clause 5.1.8 of TS 25.215 [22].

The reference point for the SFN-CFN observed time difference shall be the antenna connector of the UE.

The requirements and this test apply to all types of UTRA for the FDD UE.

8.7.4.2.2 Minimum requirements

The accuracy requirement in table 8.7.4.2.1 is valid under the following conditions:

$CPICH_RSCP_{1,2}|_{dBm} \geq -114$ dBm.

$$\left| CPICH_RSCP1|_{in\ dBm} - CPICH_RSCP2|_{in\ dBm} \right| \leq 20dB$$

$| Channel\ 1_Io|_{dBm/3.84\ MHz} - Channel\ 2_Io|_{dBm/3.84\ MHz} | \leq 20$ dB.

$$\left(\frac{I_o}{\hat{I}_{or}} \right) |_{in\ dB} - \left(\frac{CPICH_E_c}{I_{or}} \right) |_{in\ dB} \leq 20dB$$

Table 8.7.4.2.1

Parameter	Unit	Accuracy [chip]	Conditions
			Io [dBm/3.84 MHz]
SFN-CFN observed time difference	chip	± 1	-94...-50

The normative reference for this requirement is TS 25.133 [2] clauses 9.1.7.2 and A.9.1.4.2.

8.7.4.2.3 Test purpose

The purpose of this test is to verify that the SFN-CFN observed time difference measurement accuracy is within the specified limits in the clause 8.7.4.2.2. This measurement is for handover timing purposes to identify active cell and neighbour cell time difference.

8.7.4.2.4 Method of test

8.7.4.2.4.1 Initial conditions

Test environment: normal, TL/VL, TL/VH, TH/VL, TH/VH; see clauses G.2.1 and G.2.2.

Frequencies to be tested: mid range; see clause G.2.4.

During the test the timing difference between Cell 1 and 2 can be set to value from 0...9830399 chips.

In this test case both cells are in different frequency and compressed mode is applied. The gap length is 7, detailed definition is in clause C.5, set 1 of table C.5.2 except for TGRRC and TGCFN. TGPRC and TGCFN shall set to "Infinity" and "(Current CFN + (256 - TTI/10msec))mod 256". Table 8.7.4.2.2 defines the limits of signal strengths and code powers, where the requirement is applicable.

Table 8.7.4.2.2: SFN-CFN observed time difference Inter frequency tests parameters

Parameter	Unit	Test 1		Test 2		Test 3	
		Cell 1 Channel 1	Cell 2 Channel 2	Cell 1 Channel 1	Cell 2 Channel 2	Cell 1 Channel 1	Cell 2 Channel 2
UTRA RF Channel number							
CPICH_Ec/lor	dB	-10		-10		-10	
PCCPCH_Ec/lor	dB	-12		-12		-12	
SCH_Ec/lor	dB	-12		-12		-12	
PICH_Ec/lor	dB	-15		-15		-15	
DPCH_Ec/lor	dB	-15		-15		-15	
OCNS_Ec/lor	dB	-1.11		-1.11		-1.11	
\hat{I} or/loc	dB	10.1		10.1		10.1	
loc	dBm/ 3.84 MHz	$l_o - 10.6 \text{ dB} = l_{oc}$, Note 1		$l_o - 10.6 \text{ dB} = l_{oc}$, Note 1		$l_o - 10.6 \text{ dB} = l_{oc}$, Note 1	
l _o	dBm/3.84 MHz	-50		-72		-94	
Relative delay of path received from cell 2 with respect to cell 1	chip	x Note 2					
Propagation condition	-	AWGN		AWGN		AWGN	
NOTE 1: l_{oc} level shall be adjusted in each carrier frequency according the total signal power l_o at receiver input and the geometry factor \hat{I} or/ l_{oc} .							
NOTE2: For example, x= 491520 or 9830399							
Tests shall be done sequentially. Test 1 shall be done first. After test 1 has been executed test parameters for tests 2 and 3 shall be set within 5 seconds so that UE does not loose the Cell 2 in between the tests.							

- 1) A call is set up according to the test procedure specified in TS 34.108 [3] subclause 7.3.2.3. The RF parameters for Test 1 are set up according to table 8.7.4.2.2.

8.7.4.2.4.2 Procedure

- 1) SS shall transmit PHYSICAL CHANNEL RECONFIGURATION message.
- 2) UE shall transmit PHYSICAL CHANNEL RECONFIGURATION COMPLETE message.
- 3) SS shall transmit MEASUREMENT CONTROL message.
- 4) UE shall transmit periodically MEASUREMENT REPORT messages.
- 5) SS shall check "OFF" and "Tm" values in MEASUREMENT REPORT message and calculate SFN-CFN observed time difference value according to the definition in clause 5.1.8 of TS 25.215 [22]. This value shall be compared to the actual SFN-CFN observed time difference value for each MEASUREMENT REPORT message.
- 6) SS shall count number of MEASUREMENT REPORT messages transmitted by UE. After 1000 MEASUREMENT REPORT messages have been received from UE, the RF parameters are set up according to table 8.7.4.2.2 for Test 2. While RF parameters are being set up, MEASUREMENT REPORT messages from UE are ignored. SS shall wait for additional 1s and ignore the MEASUREMENT REPORT messages during this period. Then, steps 3) and 4) above are repeated. After further 1000 MEASUREMENT REPORT messages have been received from UE, the RF parameters are set up according to table 8.7.4.2.2 for Test 3. While RF parameters are being set up, MEASUREMENT REPORT messages from UE are ignored. SS shall wait for additional 1s and ignore the MEASUREMENT REPORT messages during this period. Then, steps 4) and 5) above are repeated.
- 7) After further 1000 MEASUREMENT REPORT messages have been received from UE, the SS shall transmit RRC CONNECTION RELEASE message.
- 8) UE shall transmit RRC CONNECTION RELEASE COMPLETE message.

Specific Message Contents

All messages indicated above shall use the same content as described in the default message content in clause 9 of 34.108 [3], with the following exceptions:

PHYSICAL CHANNEL RECONFIGURATION message for inter frequency measurement

Information Element	Value/Remark
Message Type	
UE Information Elements -RRC transaction identifier -Integrity check info -Integrity protection mode info -Ciphering mode info -Activation time -New U-RNTI -New C-RNTI -RRC State Indicator -UTRAN DRX cycle length coefficient	0 Not Present Not Present Not Present Not Present Not Present Not Present CELL_DCH Not Present
CN Information Elements -CN Information info	Not Present
UTRAN mobility information elements -URA identity	Not Present
RB information elements -Downlink counter synchronisation info	Not Present
PhyCH information elements -Frequency info	Not Present
Uplink radio resources -Maximum allowed UL TX power - CHOICE <i>channel requirement</i>	Not Present Not Present
Downlink radio resources -CHOICE mode -Downlink PDSCH information -Downlink information common for all radio links -Downlink DPCH info common for all RL -CHOICE mode -DPCH compressed mode info -Transmission gap pattern sequence -TGPSI -TGPS Status Flag -TGCFN -Transmission gap pattern sequence configuration parameters -TGMP -TGPRC -TGSN -TGL1 -TGL2 -TGD -TGPL1 -TGPL2 -RPP -ITP -CHOICE UL/DL mode -Downlink compressed mode method -Uplink compressed mode method -Downlink frame type -DeltaSIR1 -DeltaSIRafter1 -DeltaSIR2 -DeltaSIRafter2 -N Identify abort -T Reconfirm abort -TX Diversity Mode -SSDT information -Default DPCH Offset Value -Downlink information per radio link list -Downlink information for each radio link -Choice mode -Primary CPICH info -Primary scrambling code	FDD Not Present Not Present FDD 1 Activate (Current CFN + (256 – TTI/10msec))mod 256 FDD measurement Infinity 4 7 Not Present 0 3 Not Present Mode 0 Mode 0 UL and DL SF/2 SF/2 B 3.0 3.0 Not Present Not Present Not Present Not Present Not Present Not Present Not Present FDD 100

-PDSCH with SHO DCH Info	Not Present
-PDSCH code mapping	Not Present
-Downlink DPCH info for each RL	
-CHOICE mode	FDD
-Primary CPICH usage for channel estimation	Primary CPICH may be used
-DPCH frame offset	Set to value Default DPCH Offset Value (as currently stored in SS) mod 38400
-Secondary CPICH info	Not Present
-DL channelisation code	
-Secondary scrambling code	Not Present
-Spreading factor	128
-Code number	0
-Scrambling code change	No code change
-TPC combination index	0
-SSDT Cell Identity	Not Present
-Closed loop timing adjustment mode	Not Present
-SCCPCH Information for FACH	Not Present

MEASUREMENT CONTROL message for Inter frequency measurement

Information Element	Value/Remark
Message Type	
UE information elements -RRC transaction identifier -Integrity check info	0 Not Present
Measurement Information elements -Measurement Identity -Measurement Command -Measurement Reporting Mode - Measurement Report Transfer Mode - Periodical Reporting / Event Trigger Reporting Mode -Additional measurement list -CHOICE Measurement Type -Inter-frequency measurement -Inter-frequency cell info list -CHOICE Inter-frequency cell removal -New inter-frequency cells -Cell for measurement -Inter-frequency measurement quantity -CHOICE reporting criteria -Filter coefficient -CHOICE mode -Measurement quantity for frequency quality estimate -Inter-frequency reporting quantity -UTRA Carrier RSSI -Frequency quality estimate -Non frequency related cell reporting quantities -SFN-SFN observed time difference reporting indicator -Cell synchronisation information reporting indicator -Cell Identity reporting indicator -CHOICE mode -CPICH Ec/N0 reporting indicator -CPICH RSCP reporting indicator -Pathloss reporting indicator -Reporting cell status -CHOICE reported cell -Maximum number of reported cells -Measurement validity -Inter-frequency set update -CHOICE report criteria -Amount of reporting -Reporting interval	2 Setup Acknowledged mode RLC Periodical reporting Not Present Inter-frequency measurement Not Present Cell 2 information is included Inter-frequency reporting criteria 0 FDD CPICH RSCP TRUE TRUE No report TRUE TRUE FDD TRUE TRUE TRUE Report all active set cells + cells within monitored set on used frequency Virtual/active set cells + 2 Not Present Not Present Periodical reporting criteria Infinity 500 ms
Physical channel information elements -DPCH compressed mode status info	Not Present

MEASUREMENT REPORT message for Inter frequency test cases

This message is common for all inter frequency test cases in clause 8.7 and is described in Annex I.

8.7.4.2.5 Test requirements

The SFN-CFN observed time difference measurement accuracy shall meet the requirements in clause 8.7.4.2.2.

NOTE: If the above Test Requirement differs from the Minimum Requirement then the Test Tolerance applied for this test is non-zero. The Test Tolerance for this test is defined in clause F.2 and the explanation of how the Minimum Requirement has been relaxed by the Test Tolerance is given in clause F.4.

8.7.5 SFN-SFN observed time difference

8.7.5.1 SFN-SFN observed time difference type 1

8.7.5.1.1 Definition and applicability

This measurement is specified in clause 5.1.9 of TS 25.215 [22]. The reference point for the SFN-SFN observed time difference type 1 shall be the antenna connector of the UE.

The requirements and this test apply to all types of UTRA for the FDD UE.

8.7.5.1.2 Minimum requirements

The accuracy requirement in table 8.7.5.1.1 is valid under the following conditions:

$$CPICH_RSCP_{1,2}|_{dBm} \geq -114 \text{ dBm.}$$

$$\left| CPICH_RSCP1|_{in \text{ dBm}} - CPICH_RSCP2|_{in \text{ dBm}} \right| \leq 20 \text{ dB}$$

$$\left(\frac{I_o}{\hat{I}_{or}} \right)|_{in \text{ dB}} - \left(\frac{CPICH_E_c}{I_{or}} \right)|_{in \text{ dB}} \leq 20 \text{ dB}$$

$$\left(\frac{I_o}{\hat{I}_{or}} \right)|_{in \text{ dB}} - \left(\frac{P - CCPCH_E_c}{I_{or}} \right)|_{in \text{ dB}} \text{ is low enough to ensure successful SFN decoding.}$$

Table 8.7.5.1.1

Parameter	Unit	Accuracy [chip]	Conditions
			Io [dBm/3.84 MHz]
SFN-SFN observed time difference type1	chip	± 1	-94...-50

The normative reference for this requirement is TS 25.133 [2] clause 9.1.8.1.1 and A.9.1.5.1.2.

8.7.5.1.3 Test purpose

The purpose of this test is to verify that the measurement accuracy of SFN-SFN observed time difference type 1 is within the limit specified in clause 8.7.5.1.2. This measurement is for identifying time difference between two cells.

8.7.5.1.4 Method of test

8.7.5.1.4.1 Initial conditions

Test environment: normal; see clauses G.2.1 and G.2.2.

Frequencies to be tested: mid range; see clause G.2.4.

During the test the timing difference between Cell 1 and 2 can be set to value from 0...9830399 chips.

- 1) Connect SS to the UE antenna connector as shown in figure A.1
- 2) A call is set up according to the test procedure specified in TS 34.108 [3] subclause 7.3.2.3. The RF parameters for Test 1 are set up according to table 8.7.5.1.2.

In this case all cells are in the same frequency. Table 8.7.5.1.2 defines the limits of signal strengths and code powers, where the requirements are applicable.

Table 8.7.5.1.2: SFN-SFN observed time difference type 1 Intra frequency test parameters

Parameter	Unit	Test 1		Test 2		Test 3	
		Cell 1	Cell 2	Cell 1	Cell 2	Cell 1	Cell 2
UTRA RF Channel number		Channel 1		Channel 1		Channel 1	
CPICH_Ec/lor	dB	-10		-10		-10	
PCCPCH_Ec/lor	dB	-12		-12		-12	
SCH_Ec/lor	dB	-12		-12		-12	
PICH_Ec/lor	dB	-15		-15		-15	
DPCH_Ec/lor	dB	-15		-15		-15	
OCNS_Ec/lor	dB	-1.11		-1.11		-1.11	
$\hat{I}_{or/loc}$	dB	10.5		10.5		10.5	
loc	dBm/ 3.84 MHz	$I_o - 13.7 \text{ dB} = loc$, Note 1		$I_o - 13.7 \text{ dB} = loc$, Note 1		$I_o - 13.7 \text{ dB} = loc$, Note 1	
I _o	dBm/3.84 MHz	-50		-72		-94	
Relative delay of path received from cell 2 with respect to cell 1	chip	x Note 2					
Propagation condition	-	AWGN		AWGN		AWGN	
NOTE 1: I_{oc} level shall be adjusted according the total signal power I_o at receiver input and the geometry factor $\hat{I}_{or/loc}$.							
NOTE2: For example, x= 491520 or 9830399							
Tests shall be done sequentially. Test 1 shall be done first. After test 1 has been executed test parameters for tests 2 and 3 shall be set within 5 seconds so that UE does not loose the Cell 2 in between the tests.							

8.7.5.1.4.2 Procedure

- 1) SS shall transmit MEASUREMENT CONTROL message.
- 2) UE shall transmit periodically MEASUREMENT REPORT message.
- 3) SS shall check "SFN-SFN observed time difference type 1" value in MEASUREMENT REPORT message. The reported value shall be compared to actual SFN-SFN observed time difference type 1 value for each MEASUREMENT REPORT message.
- 4) SS shall count the number of MEASUREMENT REPORT messages transmitted by UE. After 1000 MEASUREMENT REPORT messages have been received from UE, the RF parameters are set up according to table 8.7.5.1.2 for Test 2. While RF parameters are being set up, MEASUREMENT REPORT messages from UE are ignored. SS shall wait for additional 1s and ignore the MEASUREMENT REPORT messages during this period. Then, step 3) above is repeated. After further 1000 MEASUREMENT REPORT messages have been received from UE, the RF parameters are set up according to table 8.7.5.1.2 for Test 3. While RF parameters are being set up, MEASUREMENT REPORT messages from UE are ignored. SS shall wait for additional 1s and ignore the MEASUREMENT REPORT messages during this period. Then, step 3) above is repeated.
- 5) After further 1000 MEASUREMENT REPORT messages have been received from UE, the SS shall transmit RRC CONNECTION RELEASE message.
- 6) UE shall transmit RRC CONNECTION RELEASE COMPLETE message.

Specific Message Contents

All messages indicated above shall use the same content as described in the default message content in clause 9 of 34.108 [3], with the following exceptions:

MEASUREMENT CONTROL message for Intra frequency measurement (Step 1):

Information Element	Value/Remark
Message Type	
UE information elements -RRC transaction identifier -Integrity check info	0 Not Present
Measurement Information elements -Measurement Identity -Measurement Command -Measurement Reporting Mode - Measurement Report Transfer Mode - Periodical Reporting / Event Trigger Reporting Mode -Additional measurement list-CHOICE Measurement Type -Intra-frequency measurement - Intra-frequency measurement objects list -Intra-frequency measurement quantity -Filter coefficient -CHOICE mode -Measurement quantity -Intra-frequency reporting quantity -Reporting quantities for active set cells -SFN-SFN observed time difference reporting indicator -Cell synchronisation information reporting indicator -Cell Identity reporting indicator -CHOICE mode -CPICH Ec/N0 reporting indicator -CPICH RSCP reporting indicator -Pathloss reporting indicator -Reporting quantities for monitored set cells -SFN-SFN observed time difference reporting indicator -Cell synchronisation information reporting indicator -Cell Identity reporting indicator -CHOICE mode -CPICH Ec/N0 reporting indicator -CPICH RSCP reporting indicator -Pathloss reporting indicator -Reporting quantities for detected set cells -Reporting cell status -CHOICE reported cell -Maximum number of reported cells -Measurement validity -CHOICE <i>report criteria</i> -Amount of reporting -Reporting interval	1 Modify Acknowledged mode RLC Periodical reporting Not Present Intra-frequency measurement Not Present 0 FDD CPICH RSCP Type 1 TRUE TRUE FDD TRUE TRUE TRUE Type 1 TRUE TRUE FDD TRUE TRUE TRUE Not Present Report all active set cells + cells within monitored set on used frequency Virtual/active set cells + 2 Not Present Periodical reporting criteria Infinity 250 ms
Physical channel information elements -DPCH compressed mode status info	Not Present

MEASUREMENT REPORT message for Intra frequency test cases

This message is common for all intra frequency test cases in clause 8.7 and is described in Annex I.

8.7.5.1.5 Test requirements

The SFN-SFN observed time difference type 1 accuracy shall meet the requirements in clause 8.7.5.1.2.

NOTE: If the above Test Requirement differs from the Minimum Requirement then the Test Tolerance applied for this test is non-zero. The Test Tolerance for this test is defined in clause F.2 and the explanation of how the Minimum Requirement has been relaxed by the Test Tolerance is given in clause F.4.

8.7.5.2 SFN-SFN observed time difference type 2

Void.

8.7.6 UE Rx-Tx time difference

8.7.6.1 UE Rx-Tx time difference type 1

8.7.6.1.1 Definition and applicability

The UE Rx-Tx time difference is defined as the time difference between the UE uplink DPCCCH/DPDCH frame transmission and the first detected path (in time) of the downlink DPCH frame from the measured radio link. The reference point of the UE Rx-Tx time difference shall be the antenna connector of the UE. This measurement is specified in clause 5.1.10 of TS 25.215.

The requirements and this test apply to all types of UTRA for the FDD UE.

8.7.6.1.2 Minimum requirements

Table 8.7.6.1.1

Parameter	Unit	Accuracy [chip]	Conditions
			Io [dBm/3.84Mz]
UE RX-TX time difference	chip	± 1.5	-94...-50

The normative reference for this requirement is TS 25.133 [2] clause 9.1.9.1.1 and A.9.1.6.1.2.

8.7.6.1.3 Test purpose

The purpose of this test is to verify that the measurement accuracy of Rx-Tx time difference is within the limit specified in clause 8.7.6.1.2. This measurement is used for call setup purposes to compensate propagation delay of DL and UL.

8.7.6.1.4 Method of test

8.7.6.1.4.1 Initial conditions

Test environment: normal; see clauses G.2.1 and G.2.2.

Frequencies to be tested: mid range; see clause G.2.4.

- 1) Connect SS to the UE antenna connector as shown in figure A.1

Table 8.7.6.1.2: UE Rx-Tx time difference type 1 intra frequency test parameters

Parameter	Unit	Test 1	Test 2	Test 3
		Cell 1	Cell 1	Cell 1
UTRA RF Channel number		Channel 1	Channel 1	Channel 1
CPICH_Ec/Ior	dB	-10	-10	-10
PCCPCH_Ec/Ior	dB	-12	-12	-12
SCH_Ec/Ior	dB	-12	-12	-12
PICH_Ec/Ior	dB	-15	-15	-15
DPCH_Ec/Ior	dB	-15	-15	-15
OCNS	dB	-1.11	-1.11	-1.11
\hat{I}_{or}/I_{oc}	dB	10.5	10.5	10.5
I_{oc}	dBm/ 3.84 MHz	$I_{o} - 10.9 \text{ dB} = I_{oc}$, Note 1	$I_{o} - 10.9 \text{ dB} = I_{oc}$, Note 1	$I_{o} - 10.9 \text{ dB} = I_{oc}$, Note 1
I_{o}	dBm/3.84 MHz	-94	-72	-50
Propagation condition	-	AWGN	AWGN	AWGN
NOTE 1: I_{oc} level shall be adjusted according the total signal power spectral density I_{o} at receiver input and the geometry factor \hat{I}_{or}/I_{oc} .				

8.7.6.1.4.2 Procedure

- 1) A call is set up according to the test procedure specified in TS 34.108 [3] subclause 7.3.2.3. The RF parameters are set up according to table 8.7.6.1.4 for Test 1.
- 2) SS shall transmit MEASUREMENT CONTROL message.
- 3) UE shall transmit periodically MEASUREMENT REPORT message.
- 4) SS shall check "UE Rx-Tx time difference type 1" value in MEASUREMENT REPORT message. The reported value shall be compared to actual UE Rx-Tx time difference value for each MEASUREMENT REPORT message. The comparison should be repeated 1000 times.
- 5) The RF parameters are set up according table 8.7.6.1.4 for Test 2. While RF parameters are being set up, MEASUREMENT REPORT messages from UE are ignored. SS shall wait for additional 1s and ignore the MEASUREMENT REPORT messages during this period.
- 6) Step 3) above shall be repeated.
- 7) The RF parameters are set up according table 8.7.6.1.4 for Test 3. While RF parameters are being set up, MEASUREMENT REPORT messages from UE are ignored. SS shall wait for additional 1s and ignore the MEASUREMENT REPORT messages during this period.
- 8) Step 3) above shall be repeated.
- 9) SS shall transmit RRC CONNECTION RELEASE message.

Specific Message Contents

All messages indicated above shall use the same content as described in default message content in clause 9 of 34.108 [3], with the following exceptions:

MEASUREMENT CONTROL message for Intra frequency measurement (Step 1):

Information Element	Value/Remark
Message Type	
UE information elements -RRC transaction identifier -Integrity check info	0 Not Present
Measurement Information elements -Measurement Identity -Measurement Command - Additional measurements list -Measurement Reporting Mode -Measurement Report Transfer Mode -Periodical Reporting / Event Trigger Reporting Mode -CHOICE Measurement type -UE Internal measurement quantity -CHOICE mode -Measurement quantity -Filter coefficient -UE Internal reporting quantity -UE Transmitted power -CHOICE mode -UE Rx-Tx time difference -CHOICE report criteria -Amount of reporting -Reporting interval -Measurement Reporting Mode -Measurement Report Transfer Mode -Periodical Reporting / Event Trigger Reporting Mode	1 Modify Not Present AM RLC Periodical reporting UE Internal measurement FDD UE Rx-Tx time difference 0 FALSE FDD TRUE Periodical reporting criteria Infinity 250 AM RLC Periodical reporting
Physical channel information elements -DPCH compressed mode status info	Not Present

MEASUREMENT REPORT message

Information Element	Value/remark
Message Type	
Integrity check info	The presence of this IE is dependent on IXIT statements in TS 34.123-2. If integrity protection is indicated to be active, this IE shall be present with the values of the sub IEs as stated below. Else, this IE and the sub-IEs shall be absent.
- Message authentication code	This IE is checked to see if it is present. The value is compared against the XMAC-I value computed by SS.
- RRC Message sequence number	This IE is checked to see if it is present. The value is used by SS to compute the XMAC-I value.
Measurement identity	1
Measured Results	
- CHOICE Measurement	UE Internal measured results
- Choice mode	FDD
- UE Transmitted power	Checked that this IE is absent
- UE Rx-Tx report entries	
- Primary CPICH info	Checked that this IE is present
- UE Rx-Tx time difference type 1	Checked that this IE is present
- Intra-frequency measured results	
- Cell measured results	
- Cell Identity	Not present
- SFN-SFN observed time difference	Checked that this IE is absent
- Cell synchronisation information	Checked that this IE is absent
- Primary CPICH info	
- Primary scrambling code	100
- CPICH Ec/NO	Checked that this IE is absent
- CPICH RSCP	Checked that this IE is present
- Pathloss	Checked that this IE is absent
Measured results on RACH	Checked that this IE is absent
Additional measured results	Checked that this IE is absent
Event results	Checked that this IE is absent

8.7.6.1.5 Test requirements

Table 8.7.6.1.3

Parameter	Unit	Accuracy [chip]	Conditions
			<i>Io</i> [dBm]
UE RX-TX time difference	chip	[± 2.0]	-94...-50

Table 8.7.6.1.4: UE Rx-Tx time difference type 1 intra frequency test parameters

Parameter	Unit	Test 1	Test 2	Test 3
		Cell 1	Cell 1	Cell 1
UTRA RF Channel number		Channel 1	Channel 1	Channel 1
CPICH_Ec/Ior	dB	-10	-10	-10
PCCPCH_Ec/Ior	dB	-12	-12	-12
SCH_Ec/Ior	dB	-12	-12	-12
PICH_Ec/Ior	dB	-15	-15	-15
DPCH_Ec/Ior	dB	-15	-15	-15
OCNS	dB	-1.11	-1.11	-1.11
Ior/Ioc	dB	10.5	10.5	10.5
Ioc	dBm/ 3.84 MHz	-103.6	-82.9	-62.2
Io	dBm/3.84 MHz	-92.7	-72	-51.3
Propagation condition	-	AWGN	AWGN	AWGN
NOTE 1: <i>Ioc</i> level shall be adjusted according the total signal power spectral density <i>Io</i> at receiver input and the geometry factor <i>Ior/Ioc</i> .				

The UE Rx-Tx time difference accuracy shall meet the requirements in table 8.7.6.1.3.

NOTE: If the above Test Requirement differs from the Minimum Requirement then the Test Tolerance applied for this test is non-zero. The Test Tolerance for this test is defined in clause F.2 and the explanation of how the Minimum Requirement has been relaxed by the Test Tolerance is given in clause F.4.

8.7.6.2 UE Rx-Tx time difference type 2

Void

8.7.7 Observed time difference to GSM cell

Void

8.7.8 P-CCPCH RSCP

8.7.8.1 Absolute measurement accuracy

8.7.8.1.1 Definition and applicability

The absolute accuracy of P-CCPCH RSCP is defined as the P-CCPCH RSCP measured in an UTRA TDD cell on one frequency compared to the actual P-CCPCH RSCP power of that cell on the same frequency.

The requirements and this test apply only to UE supporting both UTRA FDD and UTRA TDD.

8.7.8.1.2 Minimum Requirements

The accuracy requirement in table 8.7.8.1.1 is valid under the following conditions:

$P\text{-CCPCH_RSCP} \geq -102$ dBm,

$$\left| \frac{I_o}{\hat{I}_{or}} \right|_{in\ dB} - \left(\frac{P - CCPCH - E_c}{I_{or}} \right)_{in\ dB} \leq 8dB$$

Table 8.7.8.1.1: P-CCPCH RSCP inter frequency absolute accuracy

Parameter	Unit	Accuracy [dB]		Conditions Io [dBm/3.84 MHz]
		Normal conditions	Extreme conditions	
P-CCPCH_RSCP	dBm	± 6	± 9	-94...-70
	dBm	± 8	± 11	-70...-50

The normative reference for this requirement is TS 25.133 [2] clauses 9.1.11.1 and A.9.1.8.

8.7.8.1.3 Test purpose

The purpose of this test is to verify that the P-CCPCH RSCP absolute measurement accuracy is within the specified limits.

8.7.8.1.4 Method of test

8.7.8.1.4.1 Initial conditions

Test environment: normal, TL/VL, TL/VH, TH/VL, TH/VH; see clauses G.2.1 and G.2.2.

Frequencies to be tested: mid range; see clause G.2.4.

In this case both cells are on different frequencies. Cell 1 is a UTRA FDD cell and cell 2 is a UTRA TDD cell. The second Beacon timeslot shall be provided for cell 2 in timeslot 8. Compressed mode as specified in TS 25.101 [1] section A.5, set 3 of table A.22, is applied. TGPRC and TGCFN shall be set to "Infinity" and "(Current CFN + (256 –

TTI/10msec)) mod 256". P-CCPCH RSCP inter frequency absolute accuracy requirements are tested by using test parameters in Table 8.7.8.1.2.

Table 8.7.8.1.2: P-CCPCH RSCP inter frequency tests parameters

Parameter	Unit	Test 1		Test 2	
		Cell 1	Cell 2	Cell 1	Cell 2
DL timeslot number		n.a.	0 8	n.a.	0 8
UTRA RF Channel number		Channel 2	Channel 1	Channel 2	Channel 1
CPICH_Ec/Ior	dB	-10	n.a.	-10	n.a.
P-CCPCH_Ec/Ior	dB	-12	-3 n.a.	-12	-3 n.a.
SCH_Ec/Ior	dB	-12	-9	-12	-9
SCH_toffset		n.a.	5	n.a.	5
PICH_Ec/Ior	dB	-15	n.a. -3	-15	n.a. -3
DPCH_Ec/Ior	dB	-15	n.a.	-15	n.a.
OCNS_Ec/Ior	dB	-1.11	-3.12	-1.11	-3.12
Ior	dBm/ 3.84 MHz	-60	-57.7	-84	-84.7
Ior/Ior	dB	9.54	7	0	3
P-CCPCH RSCP, Note 1	dBm	n.a.	-53.7 n.a.	n.a.	-84.7 n.a.
CPICH RSCP, Note 1	dBm	-60.46	n.a.	-94	n.a.
Ior, Note 1	dBm/3.84 MHz	-50	-50	-81	-80
Propagation condition	-	AWGN		AWGN	
Note 1: P-CCPCH RSCP, CPICH RSCP and Ior levels have been calculated from other parameters for information purposes. They are not settable parameters themselves. Note that the transmit energy per PN chip for the SCH is averaged over the 256 chip duration when the SCH is present in the time slot.					
Tests shall be done sequentially. Test 1 shall be done first. After test 1 has been executed, test parameters for test 2 shall be set within 5 seconds so that the UE does not lose the Cell 2 in between the test.					

- 2) A call is set up according to the test procedure specified in TS 34.108 [3] clause 7.3.2.3. The RF parameters for Test 1 are set up according to table 8.7.8.1.2.

8.7.8.1.4.2 Procedure

- 1) SS shall transmit the PHYSICAL CHANNEL RECONFIGURATION message.
- 2) UE shall transmit the PHYSICAL CHANNEL RECONFIGURATION COMPLETE message.
- 3) SS shall transmit the MEASUREMENT CONTROL message.
- 4) UE shall transmit periodically MEASUREMENT REPORT messages.
- 5) SS shall check P-CCPCH RSCP values of Cell 2 in the MEASUREMENT REPORT messages. P-CCPCH RSCP power level of Cell 2 reported by the UE shall be compared to the actually set P-CCPCH RSCP value of Cell 2 for each MEASUREMENT REPORT message.
- 6) SS shall count number of MEASUREMENT REPORT messages transmitted by UE. After 1000 MEASUREMENT REPORT messages have been received from UE, the RF parameters are set up according to table 8.7.8.1.2 for Test 2. While RF parameters are being set up, MEASUREMENT REPORT messages from UE are ignored. SS shall wait for additional 1s and ignore the MEASUREMENT REPORT messages during this period. Then, steps 4) and 5) above are repeated.
- 7) After further 1000 MEASUREMENT REPORT messages have been received from UE, the SS shall transmit RRC CONNECTION RELEASE message.
- 8) UE shall transmit RRC CONNECTION RELEASE COMPLETE message.

Specific Message Contents

All messages indicated above shall use the same content as described in the default message content in clause 9 of 34.108 [3] and in Annex I, with the following exceptions:

PHYSICAL CHANNEL RECONFIGURATION message for inter frequency measurement (Step 1):

Information Element	Value/Remark
Message Type	
UE Information Elements -RRC transaction identifier -Integrity check info -Integrity protection mode info -Ciphering mode info -Activation time -New U-RNTI -New C-RNTI -RRC State Indicator -UTRAN DRX cycle length coefficient	0 Not Present Not Present Not Present Not Present Not Present Not Present CELL_DCH Not Present
CN Information Elements -CN Information info	Not Present
UTRAN mobility information elements -URA identity	Not Present
RB information elements -Downlink counter synchronisation info	Not Present
PhyCH information elements -Frequency info	Not Present
Uplink radio resources -Maximum allowed UL TX power - CHOICE <i>channel requirement</i>	Not Present Not Present
Downlink radio resources -CHOICE mode -Downlink PDSCH information -Downlink information common for all radio links -Downlink DPCH info common for all RL -CHOICE mode -DPCH compressed mode info -Transmission gap pattern sequence -TGPSI -TGPS Status Flag -TGCFN -Transmission gap pattern sequence configuration parameters -TGMP -TGPRC -TGSN -TGL1 -TGL2 -TGD -TGPL1 -TGPL2 -RPP -ITP -CHOICE UL/DL mode -Downlink compressed mode method -Uplink compressed mode method -Downlink frame type -DeltaSIR1 -DeltaSIRafter1 -DeltaSIR2 -DeltaSIRafter2 -N Identify abort -T Reconfirm abort -TX Diversity Mode -SSDT information -Default DPCH Offset Value -Downlink information per radio link list -Downlink information for each radio link -Choice mode -Primary CPICH info -Primary scrambling code	FDD Not Present Not Present FDD 1 Activate (Current CFN + (256 – TTI/10msec))mod 256 TDD measurement Infinity 10 10 Not Present 0 11 Not Present Mode 0 Mode 0 UL and DL Puncturing SF/2 A 3.0 3.0 Not Present Not Present Not Present Not Present Not Present Not Present Not Present FDD 100

-PDSCH with SHO DCH Info	Not Present
-PDSCH code mapping	Not Present
-Downlink DPCH info for each RL	
-CHOICE mode	FDD
-Primary CPICH usage for channel estimation	Primary CPICH may be used
-DPCH frame offset	Set to value Default DPCH Offset Value (as currently stored in SS) mod 38400
-Secondary CPICH info	Not Present
-DL channelisation code	
-Secondary scrambling code	Not Present
-Spreading factor	128
-Code number	0
-Scrambling code change	No code change
-TPC combination index	0
-SSDT Cell Identity	Not Present
-Closed loop timing adjustment mode	Not Present
-SCCPCH Information for FACH	Not Present

MEASUREMENT CONTROL message for inter frequency measurement (Step 3):

Information Element	Value/Remark
Message Type	
UE information elements -RRC transaction identifier -Integrity check info	0 Not Present
Measurement Information elements -Measurement Identity -Measurement Command -Measurement Reporting Mode - Measurement Report Transfer Mode - Periodical Reporting / Event Trigger Reporting Mode -Additional measurement list -CHOICE Measurement Type -Inter-frequency measurement -Inter-frequency cell info list -CHOICE Inter-frequency cell removal -New inter-frequency cells -Cell for measurement -Inter-frequency measurement quantity -CHOICE reporting criteria -Filter coefficient -CHOICE mode -Measurement quantity for frequency quality estimate -Inter-frequency reporting quantity -UTRA Carrier RSSI -Frequency quality estimate -Non frequency related cell reporting quantities -SFN-SFN observed time difference reporting indicator -Cell synchronisation information reporting indicator -Cell Identity reporting indicator -CHOICE mode -Timeslot ISCP reporting indicator -Proposed TGSN Reporting required -Primary CCPCH RSCP reporting indicator -Pathloss reporting indicator -Reporting cell status -CHOICE reported cell -Maximum number of reported cells -Measurement validity -Inter-frequency set update -CHOICE report criteria -Amount of reporting -Reporting interval	2 Setup Acknowledged mode RLC Periodical reporting Not Present Inter-frequency measurement Not Present Cell 2 information is included. Not Present Inter-frequency reporting criteria 0 TDD Primary CCPCH RSCP FALSE TRUE No report FALSE FALSE TDD FALSE FALSE TRUE FALSE Report all active set cells + cells within monitored set on used frequency Virtual/active set cells + 2 Not Present Not Present Periodical reporting criteria Infinity 500 ms
Physical channel information elements -DPCH compressed mode status info	Not Present

8.7.8.1.5 Test requirements

The PCCPCH RSCP measurement accuracy shall meet the requirements in clause 8.7.8.1.2.

NOTE: If the above Test Requirement differs from the Minimum Requirement then the Test Tolerance applied for this test is non-zero. The Test Tolerance for this test is defined in clause F.2 and the explanation of how the Minimum Requirement has been relaxed by the Test Tolerance is given in clause F.4.

Annex A (informative): Connection Diagrams

Definition of Terms

System Simulator or SS – A device or system, that is capable of generating simulated Node B signalling and analysing UE signalling responses on one or more RF channels, in order to create the required test environment for the UE under test. It will also include the following capabilities:

1. Measurement and control of the UE Tx output power through TPC commands
2. Measurement of Rx BLER and BER
3. Measurement of signalling timing and delays
4. Ability to simulate UTRAN and/or GERAN signalling

Test System – A combination of devices brought together into a system for the purpose of making one or more measurements on a UE in accordance with the test case requirements. A test system may include one or more System Simulators if additional signalling is required for the test case. The following diagrams are all examples of Test Systems.

Note: The above terms are logical definitions to be used to describe the test methods used in this document (TS34.121), in practice, real devices called 'System Simulators' may also include additional measurement capabilities or may only support those features required for the test cases they are designed to perform.

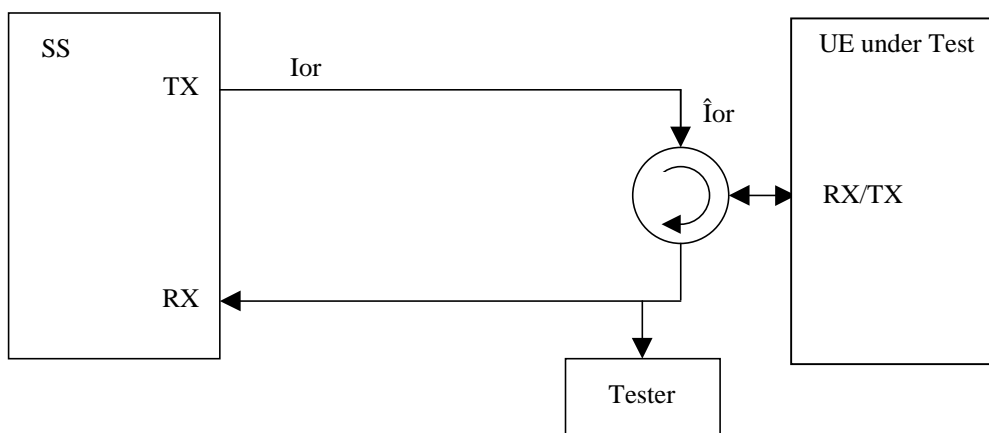

Figure A.1: Connection for Basic TX Test

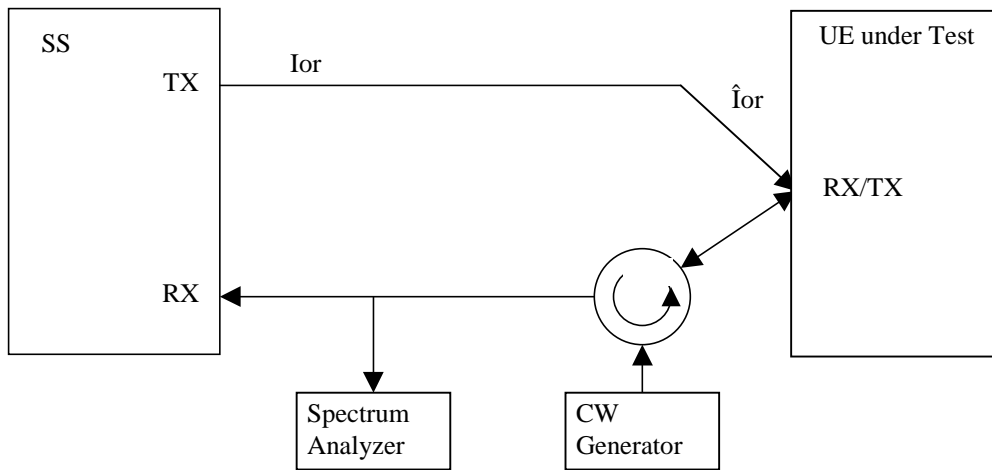

Figure A.2: Connection for TX Intermodulation Test

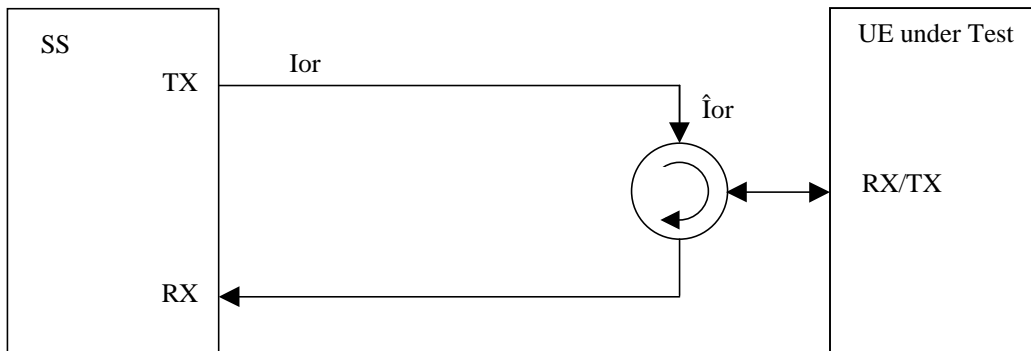

Figure A.3: Connection for Basic RX Test

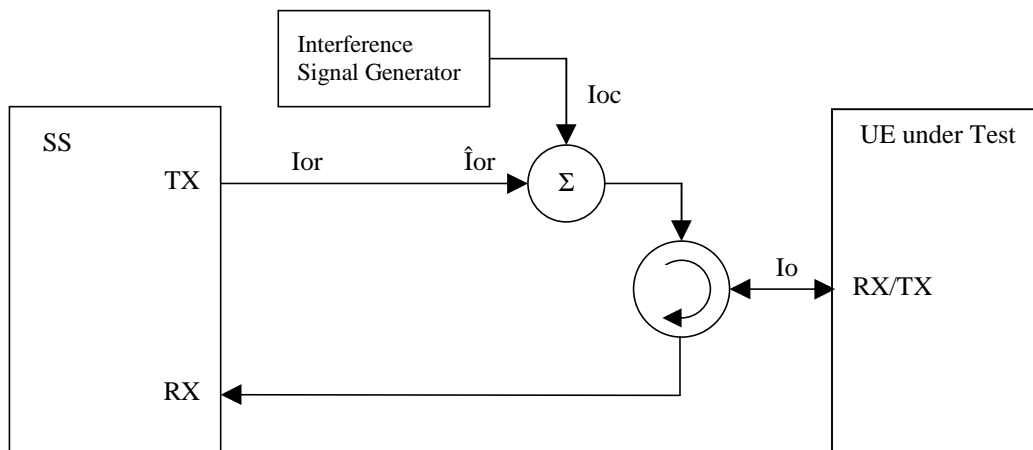

Figure A.4: Connection for RX Test with Interference

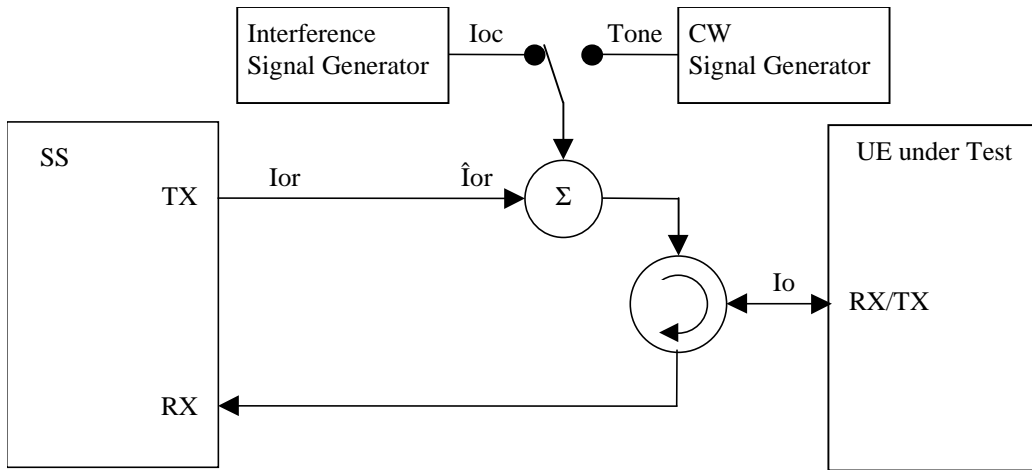

Figure A.5: Connection for RX Test with Interference or additional CW

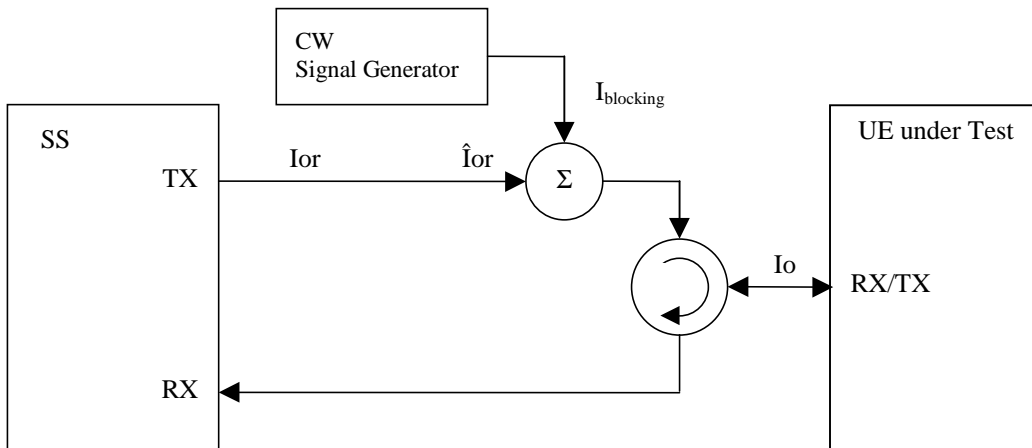

Figure A.6: Connection for RX Test with additional CW

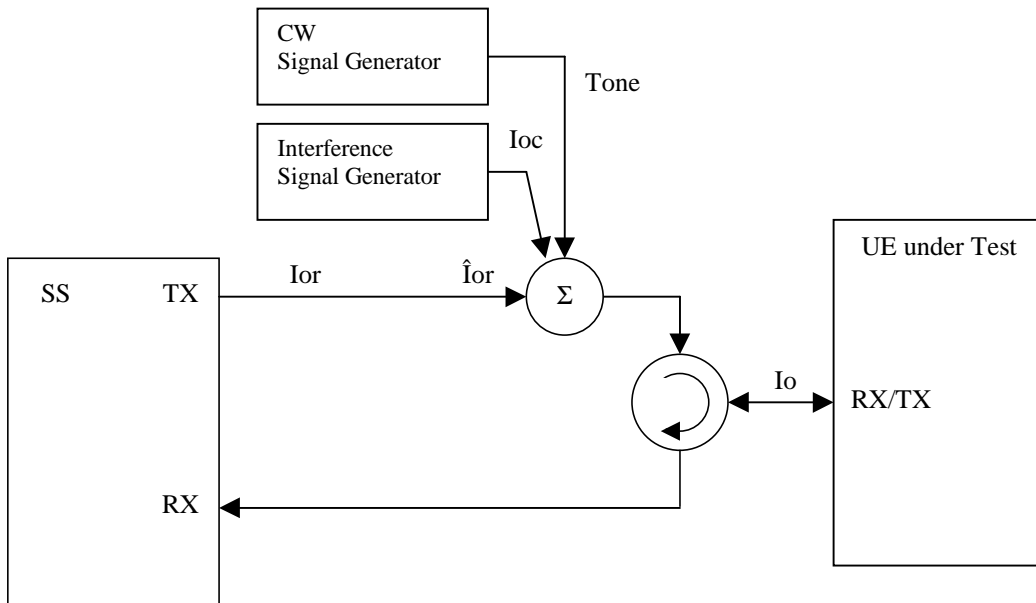

Figure A.7: Connection for RX Test with both Interference and additional CW

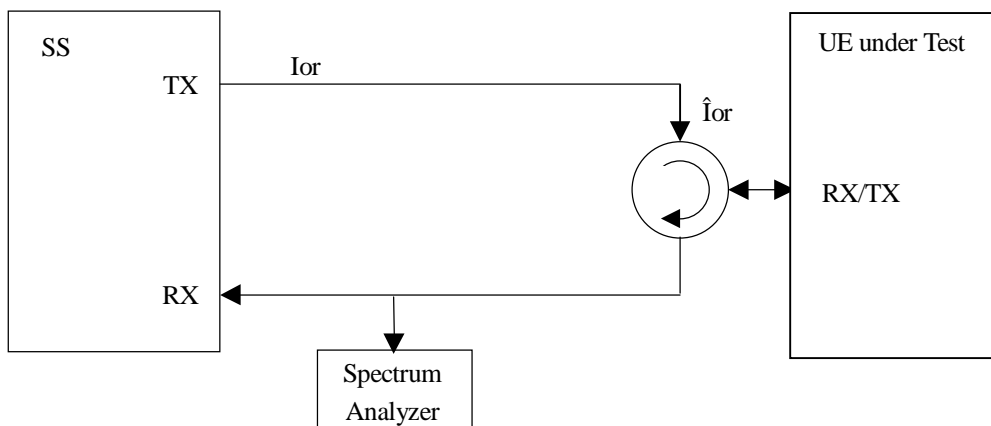

Figure A.8: Connection for Spurious Emission Test

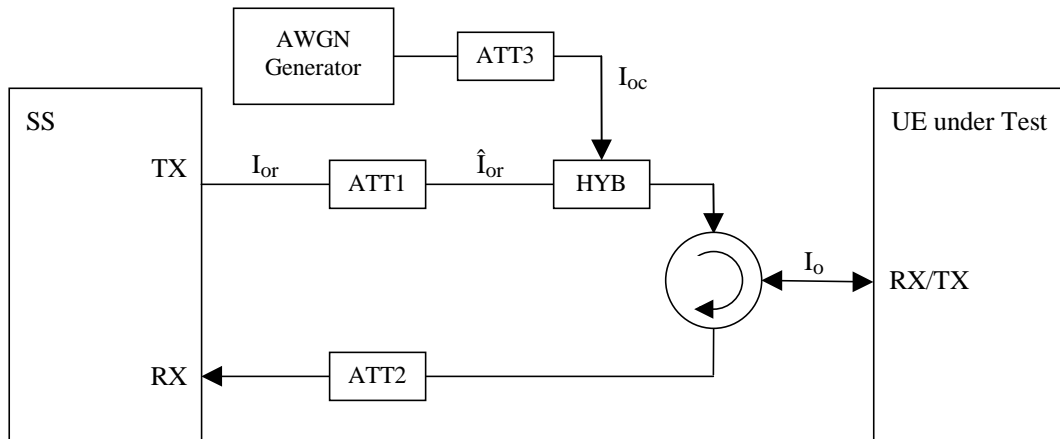

Figure A.9: Connection for Static Propagation Test

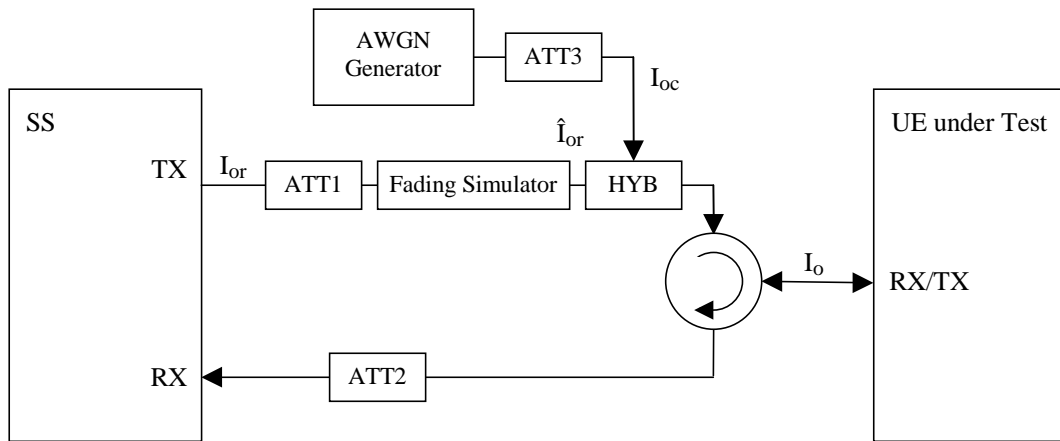

Figure A.10: Connection for Multi-path Fading Propagation Test

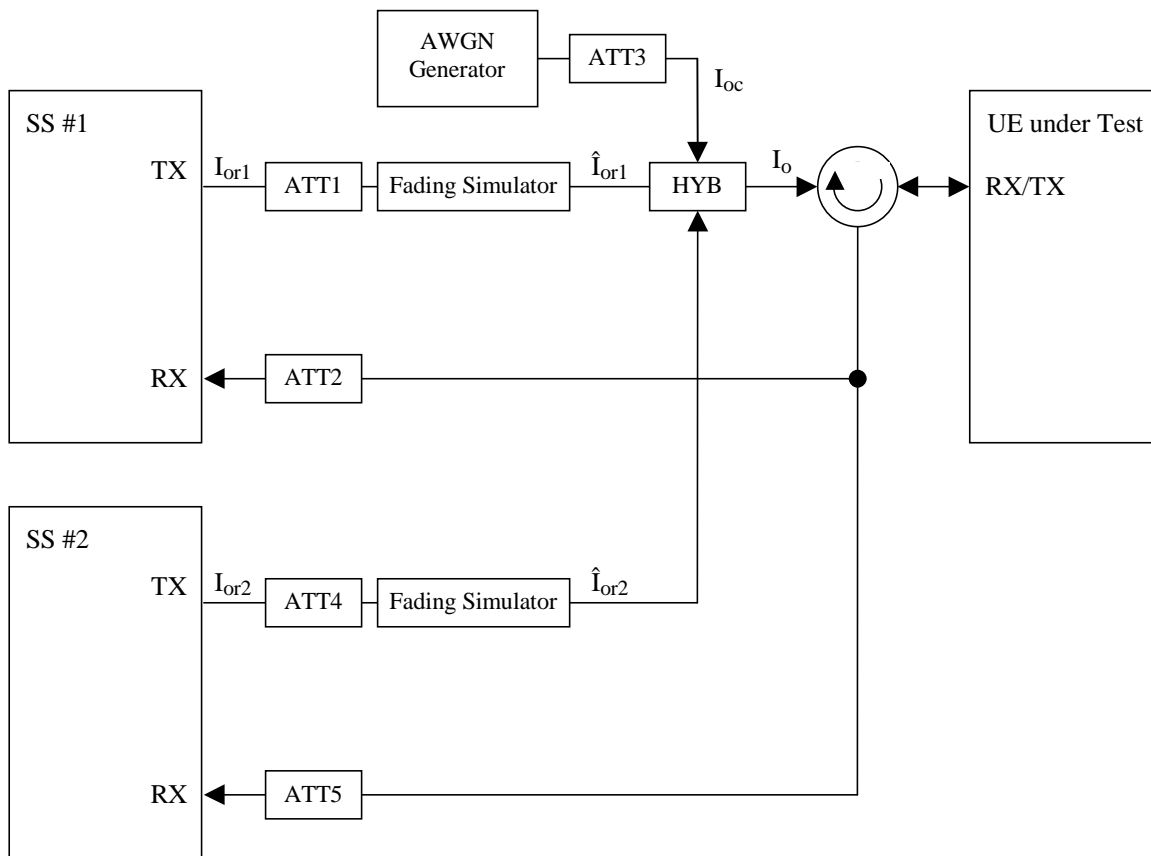

Figure A.11: Connection for Inter-Cell Soft Handover Test

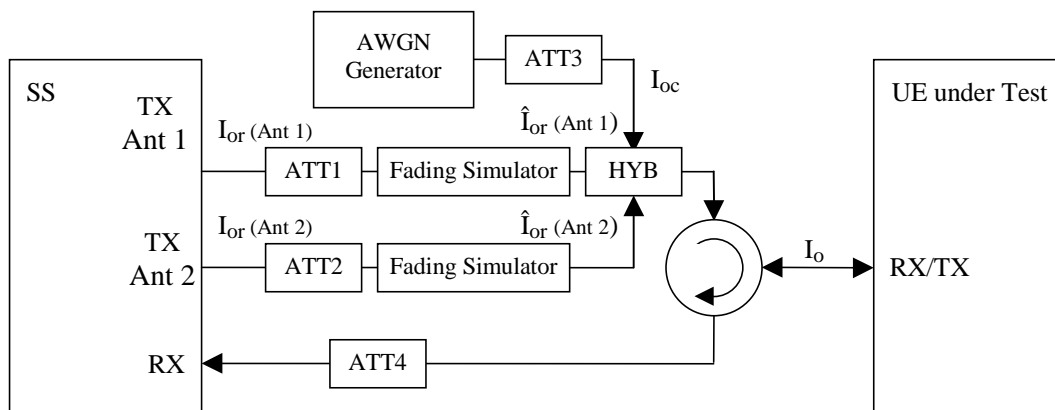

Figure A.12: Connection for Demodulation of DCH in open and closed loop transmit diversity modes

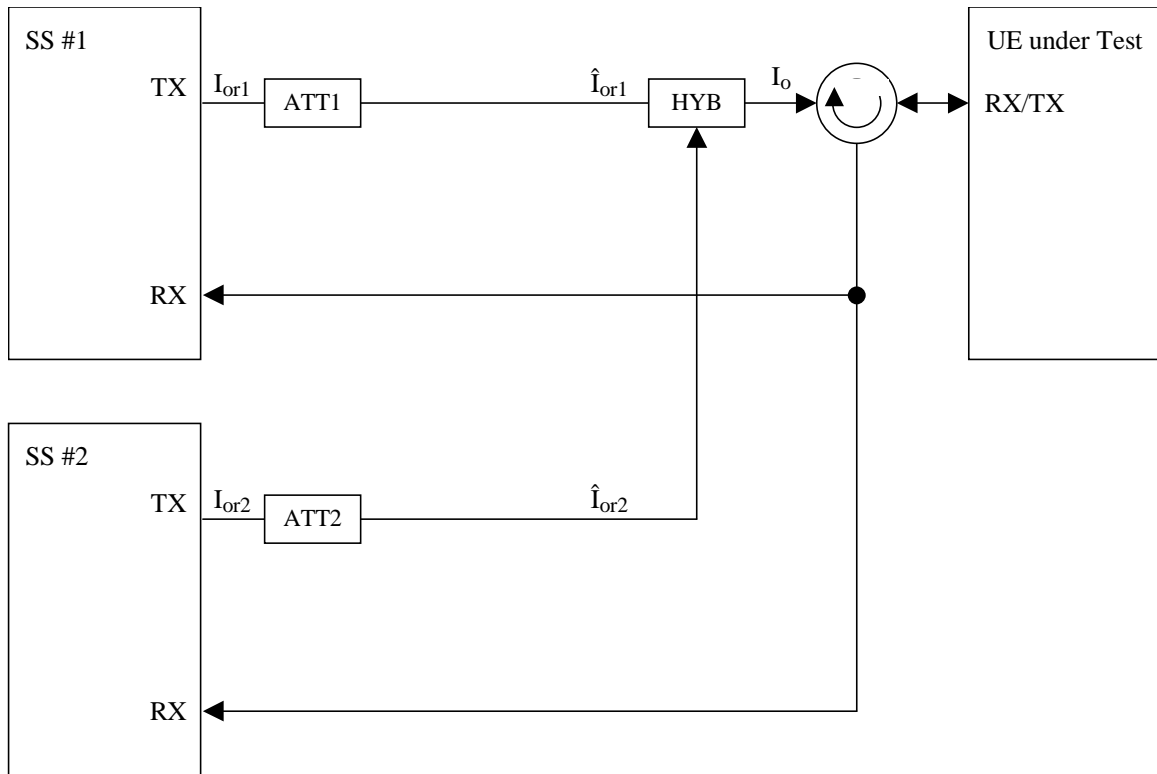

Figure A.13: Connection for Combining of TPC commands in Soft Handover Test 1

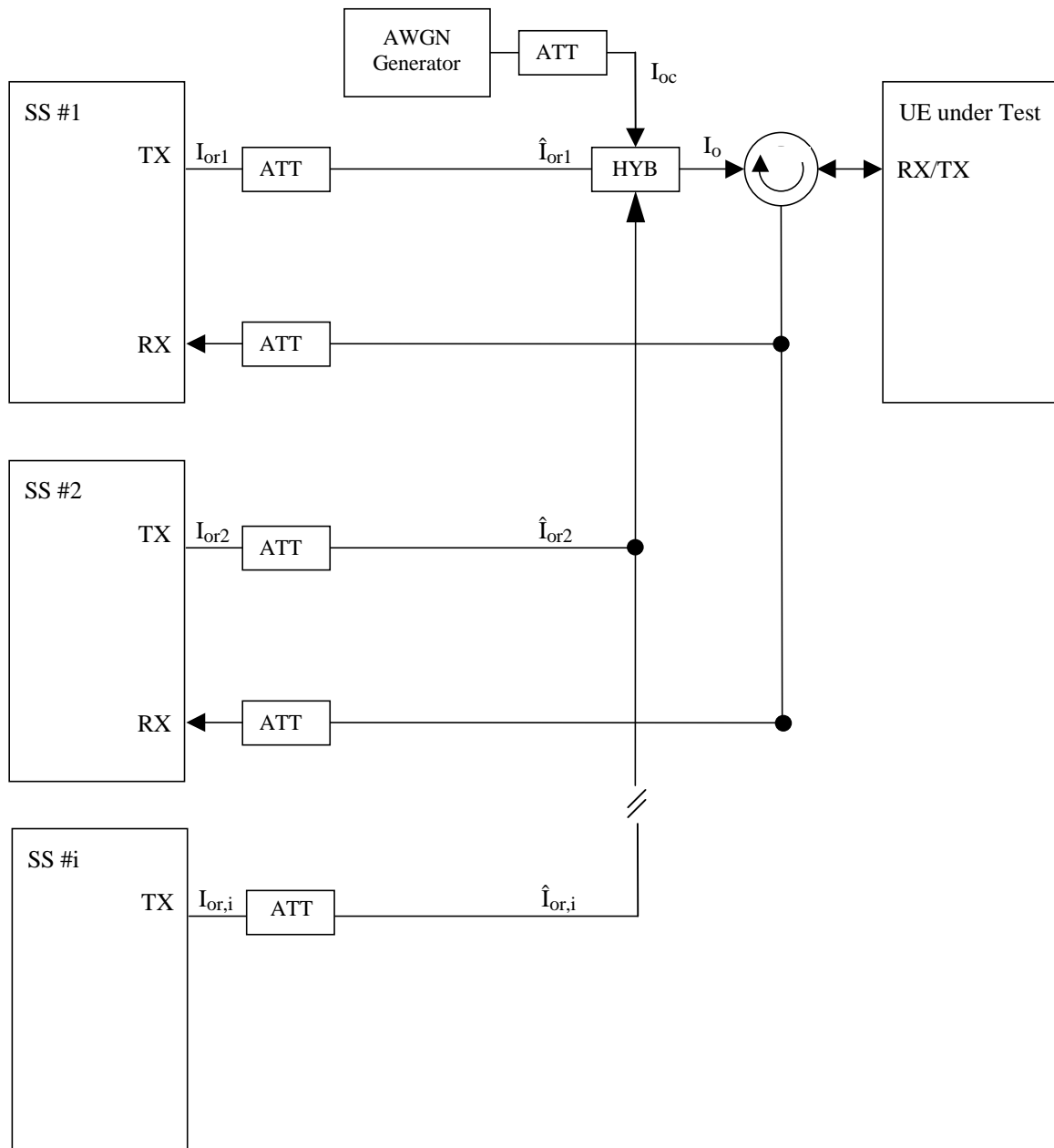

Figure A.14: Connection for cell reselection single carrier multi cell

Annex B (normative): Global In-Channel TX-Test

B.1 General

The global in-channel Tx test enables the measurement of all relevant parameters that describe the in-channel quality of the output signal of the Tx under test in a single measurement process.

The parameters describing the in-channel quality of a transmitter, however, are not necessarily independent. The algorithm chosen for description inside this annex places particular emphasis on the exclusion of all interdependencies among the parameters. Any other algorithm (e.g. having better computational efficiency) may be applied, as long as the results are the same within the acceptable uncertainty of the test system as defined in annex F.

All notes referred in the various clauses of B.2 are put together in B.3.

B.2 Definition of the process

B.2.1 Basic principle

The process is based on the comparison of the actual **output signal of the TX under test**, received by an ideal receiver, with a **reference signal**, that is generated by the measuring equipment and represents an ideal error free received signal. The reference signal shall be composed of the same number of codes at the correct spreading factors as contained in the test signal. Note, for simplification, the notation below assumes only codes of one spreading factor although the algorithm is valid for signals containing multiple spreading factors. All signals are represented as equivalent (generally complex) baseband signals.

B.2.2 Output signal of the TX under test

The output signal of the TX under test is acquired by the measuring equipment, filtered by a matched filter (RRC 0.22, correct in shape and in position on the frequency axis) and stored for further processing.

The following form represents the physical signal in the entire measurement interval:

one vector **Z**, containing $N = n_s \times sf$ complex samples;

with

n_s : number of symbols in the measurement interval;

sf : number of chips per symbol. (sf : spreading factor) (see Note: Symbol length)

B.2.3 Reference signal

The reference signal is constructed by the measuring equipment according to the relevant TX specifications.

It is filtered by the same matched filter, mentioned in clause B.2.2., and stored at the Inter-Symbol-Interference free instants. The following form represents the reference signal in the entire measurement interval:

- one vector **R**, containing $N = n_s \times sf$ complex samples;

- n_s, sf : see clause B.2.2.

B.2.4 Void

B.2.5 Classification of measurement results

The measurement results achieved by the global in-channel TX test can be classified into two types:

- Results of type "deviation", where the error-free parameter has a non-zero magnitude. (These are the parameters that quantify the integral physical characteristic of the signal). These parameters are:

RF Frequency;

Power (in case of single code);

Code Domain Power (in case of multi code);

Timing

(Additional parameters: see Note: Deviation).

- Results of type "residual", where the error-free parameter has value zero. (These are the parameters that quantify the error values of the measured signal, whose ideal magnitude is zero). These parameters are:

Error Vector Magnitude (EVM);

Peak Code Domain Error (PCDE).

(Additional parameters: see Note Residual)

B.2.6 Process definition to achieve results of type "deviation"

The reference signal (**R**; see clause B.2.3) and the signal under Test (**Z**; see subclause B.2.2) are varied with respect to the parameters mentioned in clause B.2.5 under "results of type deviation" in order to achieve best fit. Best fit is achieved when the RMS difference value between the varied signal under test and the varied reference signal is an absolute minimum.

Overview:

$$FCT [Z(\tilde{f}, \tilde{t}, \tilde{\varphi}, g_1, g_2, \dots, g_{synch}) - R(f, t, \varphi, \tilde{g}_1, \tilde{g}_2, \dots, \tilde{g}_{synch})] = Minimum \quad !$$

Z: Signal under test.

R: Reference signal,

with frequency f , the timing t , the phase φ , gain of code1 (g_1), gain of code2 (g_2) etc, and the gain of the synch channel g_{synch} . See Note: Power Step.

The parameters marked with a tilde in Z and R are varied in order to achieve a best fit.

Detailed formula: see Note: Formula for the minimum process.

The varied reference signal, after the best fit process, will be called **R'**.

The varied signal under test, after the best fit process, will be called **Z'**.

The varying parameters, leading to **R'** and **Z'** represent directly the wanted results of type "deviation". These measurement parameters are expressed as deviation from the reference value with units same as the reference value.

In case of multi code, the type-"deviation"-parameters (frequency, timing and (RF-phase)) are varied commonly for all codes such that the process returns one frequency-deviation, one timing deviation, (one RF-phase –deviation).

(These parameters are not varied on the individual codes signals such that the process would return kr frequency errors... . (kr : number of codes in the reference signal)).

The only type-"deviation"-parameters varied individually are the code domain gain factors (g_1, g_2, \dots).

B.2.6.1 Decision Point Power

The mean-square value of the signal-under-test, sampled at the best estimate of the of Intersymbol-Interference-free points using the process defined in subclause 2.5, is referred to the *Decision Point Power* (DPP):

$$DPP = \text{mean}(|Z|^2)$$

B.2.6.2 Code-Domain Power

The samples, Z , are separated into symbol intervals to create ns time-sequential vectors \mathbf{z} with sf complex samples comprising one symbol interval. The *Code Domain Power* is calculated according to the following steps:

- 1) Take the vectors \mathbf{z} defined above.
- 2) To achieve meaningful results it is necessary to descramble \mathbf{z} , leading to \mathbf{z}' (see Note1: Scrambling code)
- 3) Take the orthogonal vectors of the channelization code set \mathbf{C} (all codes belonging to one spreading factor) as defined in TS 25.213 and TS 25.223 (range +1, -1), and normalize by the norm of the vectors to produce $\mathbf{C}_{\text{norm}} = \mathbf{C} / \text{sqrt}(sf)$. (see Note: Symbol length)
- 4) Calculate the inner product of \mathbf{z}' with \mathbf{C}_{norm} . Do this for all symbols of the measurement interval and for all codes in the code space.
This gives an array of format $k \times ns$, each value representing a specific symbol and a specific code, which can be exploited in a variety of ways.

k : total number of codes in the code space

ns : number of symbols in the measurement interval

- 5) Calculate k mean-square values, each mean-square value unifying ns symbols within one code. (These values can be called "*Absolute CodeDomainPower* (CDP)" [Volt²].) The sum of the k values of CDP is equal to DPP.
- 6) Normalize by the decision point power to obtain

$$\text{Relative CodeDomain Power} = \frac{\text{Absolute CodeDomainPower}}{\text{DecisionPointPower}}$$

B.2.7 Process definition to achieve results of type "residual"

The difference between the varied reference signal (\mathbf{R}' ; see clause B.2.6.) and the varied TX signal under test (\mathbf{Z}' ; see clause B.2.6) is the error vector \mathbf{E} versus time:

$$\mathbf{E} = \mathbf{Z}' - \mathbf{R}'$$

Depending on the parameter to be evaluated, it is appropriate to represent \mathbf{E} in one of the following two different forms:

Form EVM (representing the physical error signal in the entire measurement interval)

One vector \mathbf{E} , containing $N = ns \times sf$ complex samples;

ns, sf : see B.2.2

Form PCDE (derived from Form EVM by separating the samples into symbol intervals)

ns time-sequential vectors \mathbf{e} with sf complex samples comprising one symbol interval.

\mathbf{E} gives results of type "residual" applying the two algorithms defined in clauses B 2.7.1 and B 2.7.2.

B.2.7.1 Error Vector Magnitude (EVM)

The Error Vector Magnitude EVM is calculated according to the following steps:

- 1) Take the error vector **E** defined in clause B.2.7 (Form EVM) and calculate the RMS value of **E**; the result will be called RMS(**E**).
- 2) Take the varied reference vector **R'** defined in clause B.2.6 and calculate the RMS value of **R'**; the result will be called RMS(**R'**).
- 3) Calculate EVM according to:

$$\text{EVM} = \frac{\text{RMS}(\mathbf{E})}{\text{RMS}(\mathbf{R}')} \times 100\% \quad (\text{here, EVM is relative and expressed in \%})$$

(see Note: Formula for EVM)

B.2.7.2 Peak Code Domain Error (PCDE)

The Peak Code Domain Error is calculated according to the following steps:

- 1) Take the error vectors **e** defined in clause B.2.7 (Form PCDE)
- 2) To achieve meaningful results it is necessary to descramble **e**, leading to **e'** (see Note1: Scrambling code)
- 3) Take the orthogonal vectors of the channelisation code set **C** (all codes belonging to one spreading factor) as defined in TS 25.213 and TS 25.223 (range +1, -1). (see Note: Symbol length) and normalize by the norm of the vectors to produce **Cnorm**= **C**/sqrt(sf). (see Note: Symbol length)
- 4) Calculate the inner product of **e'** with **Cnorm**. Do this for all symbols of the measurement interval and for all codes in the code space.
This gives an array of format $k \times n_s$, each value representing an error-vector representing a specific symbol and a specific code, which can be exploited in a variety of ways.
k: total number of codes in the code space
ns: number of symbols in the measurement interval
- 5) Calculate k RMS values, each RMS value unifying ns symbols within one code.
(These values can be called "*Absolute CodeEVMs*" [Volt].)
- 6) Find the peak value among the k "*Absolute CodeEVMs*".
(This value can be called "*Absolute PeakCodeEVM*" [Volt].)
- 7) Calculate PCDE according to:

$$10 \cdot \lg \frac{(\text{"Absolute PeakCodeEVM"})^2}{(\text{RMS}(\mathbf{R}'))^2} \quad \text{dB} \quad (\text{a relative value in dB}).$$

(see Note2: Scrambling code)

(see Note IQ)

B.3 Notes

Note: Symbol length)

A general code multiplexed signal is multicode and multirate. In order to avoid unnecessary complexity, the measurement applications use a unique symbol-length, corresponding to a spreading factor, regardless of the really intended spreading factor. Nevertheless the complexity with a multicode / multirate signal can be mastered by introducing appropriate definitions.

Note: Deviation)

It is conceivable to regard more parameters as type „deviation" e.g. Chip frequency and RF-phase.

As chip-frequency and RF-frequency are linked together by a statement in the core specifications [1] it is sufficient to process RF frequency only.

A parameter RF-phase must be varied within the best fit process (B 2.6.). Although necessary, this parameter-variation doesn't describe any error, as the modulation schemes used in the system don't depend on an absolute RF-phase.

Note: Residual)

It is conceivable to regard more parameters as type „residual" e.g. IQ origin offset. As it is not the intention of the test to separate for different error sources, but to quantify the quality of the signal, all such parameters are not extracted by the best fit process, instead remain part of EVM and PCDE.

Note 1: Scrambling Code)

In general a TX signal under test can use more than one scrambling code. Note that PCDE is processed regarding the unused channelisation - codes as well. In order to know which scrambling code shall be applied on unused channelisation -codes, it is necessary to restrict the test conditions: TX signal under test shall use exactly one scrambling code.

Note 2: Scrambling Code)

To interpret the measurement results in practice it should be kept in mind that erroneous code power on unused codes is generally de-scrambled differently under test conditions and under real life conditions, whereas erroneous code power on used codes is generally de-scrambled equally under test conditions and under real life conditions. It might be indicated if a used or unused code hits PCDE.

Note IQ)

As in FDD/uplink each code can be used twice, on the I and on the Q channel, the measurement result may indicate separate values of CDP or PCDE for I and Q on which channel (I or Q) they occur.

Note: **Fomula for the minimum process**

$$L (\Delta \tilde{f}, \Delta \tilde{t}, \Delta \tilde{\varphi}, \Delta \tilde{g}_c, \dots) = \sum_{\nu=0}^{N-1} |Z(\nu) - R(\nu)|^2$$

Legend:

L : the function to be minimised

The parameters to be varied in order to minimize are:

$\Delta \tilde{f}$: the RF frequency offset

$\Delta \tilde{t}$: the timing offset

$\Delta \tilde{\varphi}$: the phase offset

$\Delta \tilde{g}_c \dots$ code power offsets (one offset for each code)

$Z(v)$: Samples of the signal under Test

$R(v)$: Samples of the reference signal

$\sum_{v=0}^{N-1}$: counting index v starting at the beginning of the measurement interval and ending at its end.

N = No of chips during the measurement interval.

$Z(v)$: Samples of the signal under Test. It is modelled as a sequence of complex baseband samples $Z(\gamma)$ with a time-shift Δt , a frequency offset Δf , a phase offset $\Delta \phi$, the latter three with respect to the reference signal.

$$Z(v) = Z(v - \Delta \tilde{t}) * e^{-j2\pi\Delta f v} * e^{-j\Delta \tilde{\phi}}$$

$R(v)$: Samples of the reference signal:

$$R(v) = \sum_{c=1}^{\text{No. of codes}} (g_c + \Delta \tilde{g}_c) * \text{Chip}_c(v)$$

g : nominal gain of the code channel

$\Delta \tilde{g}$: The gain offset to be varied in the minimum process

$\text{Chip}(v)$ is the chipsequence of the code channel

Indices at g , Δg and Chip :

The index indicates the code channel: $c = 1, 2, \dots$ No of code channels

Range for Chip_c : +1,-1

Note: **Formula for EVM**

$$EVM = \sqrt{\frac{\sum_{\nu=0}^{N-1} |Z'(\gamma) - R'(\gamma)|^2}{\sum_{\nu=0}^{N-1} |R'(\gamma)|^2}} * 100 \%$$

$Z'(\gamma)$, $R'(\gamma)$ are the varied measured and reference signals.

Annex C (normative): Measurement channels

C.1 General

The measurement channels in this annex are defined to derive the requirements in clauses 5, 6 and 7. The measurement channels represent example configuration of radio access bearers for different data rates.

The measurement channel for 12,2 kbps shall be supported by any UE both in up- and downlink. Support for other measurement channels is depending on the UE Radio Access capabilities.

C.2 UL reference measurement channel

C.2.1 UL reference measurement channel (12,2 kbps)

The parameters for the 12,2 kbps UL reference measurement channel are specified in table C.2.1.1, table C 2.1.2, table C 2.1.3 and table C.2.1.4. The channel coding for information is shown in figure C.2.1. When the UE test loop function is needed, the UE test loop mode 2 shall be used.

Table C.2.1.1: UL reference measurement channel physical parameters (12,2 kbps)

Parameter	Level	Unit
Information bit rate	12,2	kbps
DPDCH	60	kbps
DPCCH	15	kbps
DPCCH Slot Format #i	0	-
DPCCH/DPDCH power ratio	-5,46	dB
TFCI	On	-
Repetition	23	%
NOTE:	Slot Format #2 is used for closed loop tests in clause 7.6.2. Slot Format #2 and #5 are used for site selection diversity transmission tests in subclause 7.6.3.	

Table C.2.1.2: UL reference measurement channel using RLC-TM for DTCH, transport channel parameters (12.2 kbps)

Higher Layer	RAB/Signalling RB	RAB	SRB	
RLC	Logical channel type	DTCH	DCCH	
	RLC mode	TM	UM/AM	
	Payload sizes, bit	244	88/80	
	Max data rate, bps	12200	2200/2000	
	PDU header, bit	N/A	8/16	
	TrD PDU header, bit	0	N/A	
MAC	MAC header, bit	0	4	
	MAC multiplexing	N/A	Yes	
Layer 1	TrCH type	DCH	DCH	
	Transport Channel Identity	1	5	
	TB sizes, bit	244	100	
	TFS	TF0, bits	0*244	0*100
		TF1, bits	1*244	1*100
	TTI, ms	20	40	
	Coding type	Convolution Coding	Convolution Coding	
	Coding Rate	1/3	1/3	
	CRC, bit	16	12	
	Max number of bits/TTI after channel coding	804	360	
	Uplink: Max number of bits/radio frame before rate matching	402	90	
	RM attribute	256	256	

Table C.2.1.3: UL reference measurement channel using RLC-AM for DTCH, transport channel parameters (12.2 kbps)

Higher Layer	RAB/Signalling RB	RAB	SRB	
RLC	Logical channel type	DTCH	DCCH	
	RLC mode	AM	UM/AM	
	Payload sizes, bit	228	88/80	
	Max data rate, bps	11400	2200/2000	
	PDU header, bit	16	8/16	
	TrD PDU header, bit	N/A	N/A	
MAC	MAC header, bit	0	4	
	MAC multiplexing	N/A	Yes	
Layer 1	TrCH type	DCH	DCH	
	Transport Channel Identity	1	5	
	TB sizes, bit	244	100	
	TFS	TF0, bits	0*244	0*100
		TF1, bits	1*244	1*100
	TTI, ms	20	40	
	Coding type	Convolution Coding	Convolution Coding	
	Coding Rate	1/3	1/3	
	CRC, bit	16	12	
	Max number of bits/TTI after channel coding	804	360	
	Uplink: Max number of bits/radio frame before rate matching	402	90	
	RM attribute	256	256	

Table C.2.1.4: UL reference measurement channel, TFCS (12.2 kbps)

TFCS size	4
TFCS	(DTCH, DCCH)= (TF0, TF0), (TF1, TF0), (TF0, TF1), (TF1, TF1)

NOTE: The TFCs except for (TF1, TF1) are belonging to minimum set of TFCs.

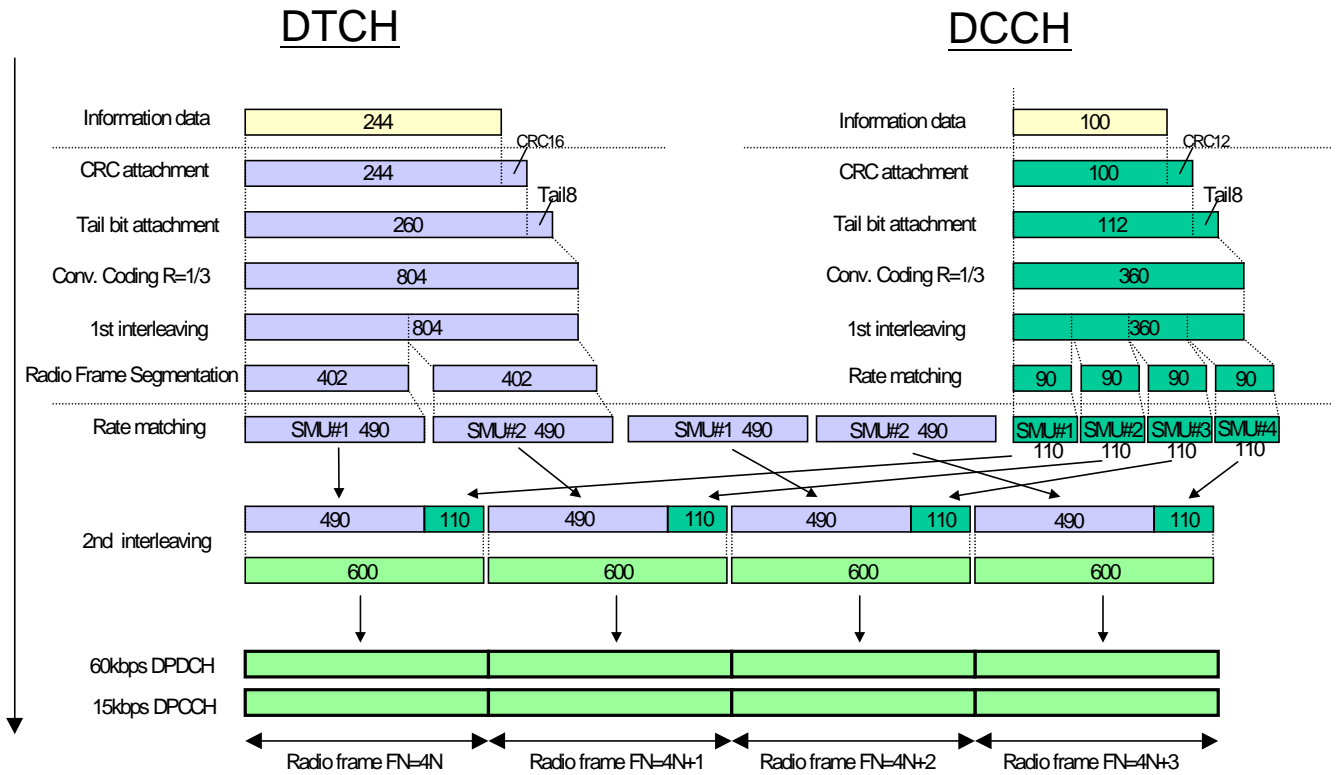

Figure C.2.1 (Informative): Channel coding of UL reference measurement channel (12,2 kbps)

C.2.2 UL reference measurement channel (64 kbps)

The parameters for the 64 kbps UL reference measurement channel are specified in table C.2.2.1, table C.2.2.2, table C.2.2.3 and table C.2.2.4. The channel coding for information is shown in figure C.2.2. When the UE test loop function is needed, the UE test loop mode 2 shall be used. This measurement channel is not currently used in the present document but can be used for future requirements.

Table C.2.2.1: UL reference measurement channel (64 kbps)

Parameter	Level	Unit
Information bit rate	64	kbps
DPDCH	240	kbps
DPCCH	15	kbps
DPCCH Slot Format #i	0	-
DPCCH/DPDCH	-9,54	dB
TFCI	On	-
Repetition	18	%

Table C.2.2.2: UL reference measurement channel using RLC-TM for DTCH, transport channel parameters (64 kbps)

Higher Layer	RAB/Signalling RB	RAB	SRB	
RLC	Logical channel type	DTCH	DCCH	
	RLC mode	TM	UM/AM	
	Payload sizes, bit	1280	88/80	
	Max data rate, bps	64000	2200/2000	
	PDU header, bit	N/A	8/16	
	TrD PDU header, bit	0	N/A	
MAC	MAC header, bit	0	4	
	MAC multiplexing	N/A	Yes	
Layer 1	TrCH type	DCH	DCH	
	Transport Channel Identity	1	5	
	TB sizes, bit	1280	100	
	TFS	TF0, bits	0*1280	0*100
		TF1, bits	1*1280	1*100
	TTI, ms	20	40	
	Coding type	Turbo Coding	Convolution Coding	
	Coding Rate	N/A	1/3	
	CRC, bit	16	12	
	Max number of bits/TTI after channel coding	3900	360	
	Uplink: Max number of bits/radio frame before rate matching	1950	90	
	RM attribute	256	256	

Table C.2.2.3: UL reference measurement channel using RLC-AM for DTCH, transport channel parameters (64 kbps)

Higher Layer	RAB/Signalling RB	RAB	SRB	
RLC	Logical channel type	DTCH	DCCH	
	RLC mode	AM	UM/AM	
	Payload sizes, bit	1264	88/80	
	Max data rate, bps	63200	2200/2000	
	PDU header, bit	16	8/16	
	TrD PDU header, bit	N/A	N/A	
MAC	MAC header, bit	0	4	
	MAC multiplexing	N/A	Yes	
Layer 1	TrCH type	DCH	DCH	
	Transport Channel Identity	1	5	
	TB sizes, bit	1280	100	
	TFS	TF0, bits	0*1280	0*100
		TF1, bits	1*1280	1*100
	TTI, ms	20	40	
	Coding type	Turbo Coding	Convolution Coding	
	Coding Rate	N/A	1/3	
	CRC, bit	16	12	
	Max number of bits/TTI after channel coding	3900	360	
	Uplink: Max number of bits/radio frame before rate matching	1950	90	
	RM attribute	256	256	

Table C.2.2.4: UL reference measurement channel, TFCS (64 kbps)

TFCS size	4
TFCS	(DTCH, DCCH)= (TF0, TF0), (TF1, TF0), (TF0, TF1), (TF1, TF1)

NOTE: The TFCs except for (TF1, TF1) are belonging to minimum set of TFCs.

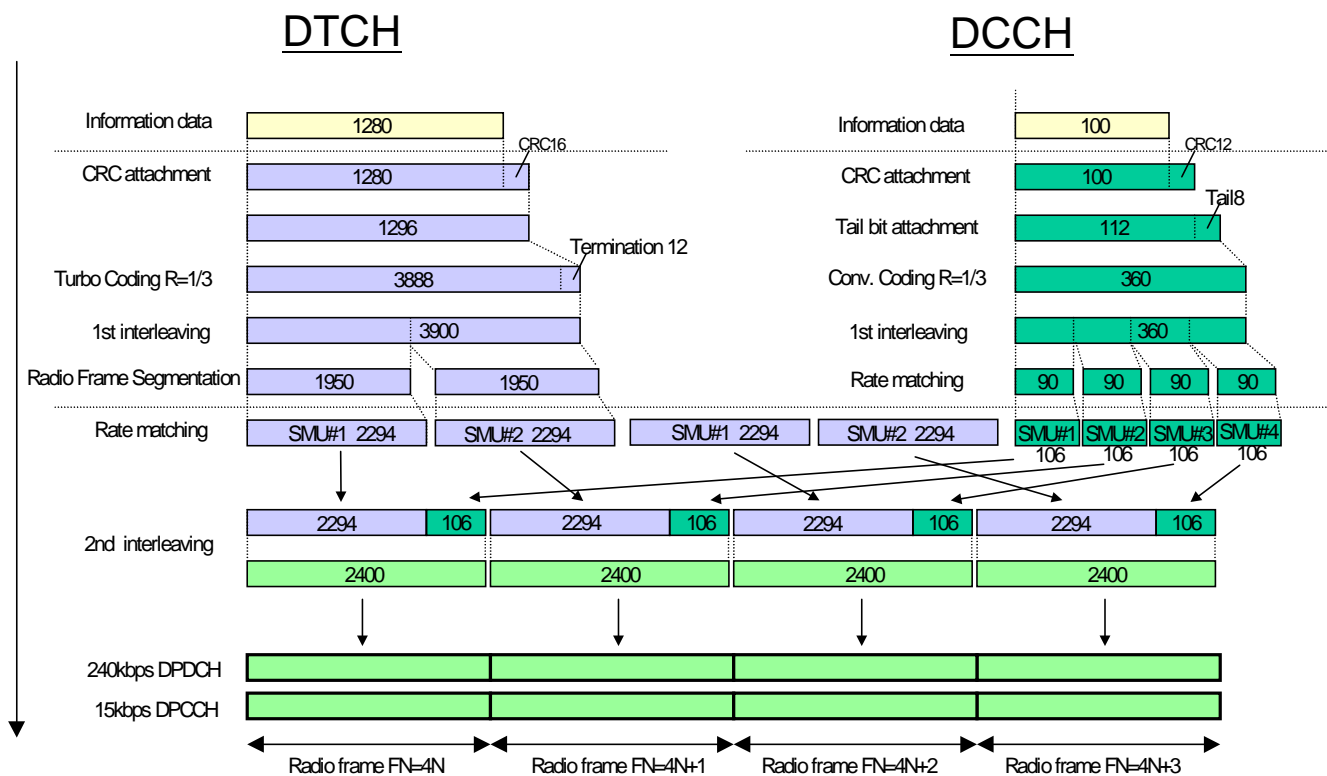

Figure C.2.2 (Informative): Channel coding of UL reference measurement channel (64 kbps)

C.2.3 UL reference measurement channel (144 kbps)

The parameters for the 144 kbps UL reference measurement channel are specified in table C.2.3.1, table C.2.3.2, table C.2.3.3 and table C.2.3.4. The channel coding for information is shown in figure C.2.3. When the UE test loop function is needed, the UE test loop mode 2 shall be used. This measurement channel is not currently used in the present document but can be used for future requirements.

Table C.2.3.1: UL reference measurement channel (144 kbps)

Parameter	Level	Unit
Information bit rate	144	kbps
DPDCH	480	kbps
DPCCH	15	kbps
DPCCH Slot Format #i	0	-
DPCCH/DPDCH power ratio	-11,48	dB
TFCI	On	-
Repetition	8	%

Table C.2.3.2: UL reference measurement channel using RLC-TM for DTCH, transport channel parameters (144 kbps)

Higher Layer	RAB/Signalling RB	RAB	SRB	
RLC	Logical channel type	DTCH	DCCH	
	RLC mode	TM	UM/AM	
	Payload sizes, bit	2880	88/80	
	Max data rate, bps	144000	2200/2000	
	PDU header, bit	N/A	8/16	
	TrD PDU header, bit	0	N/A	
MAC	MAC header, bit	0	4	
	MAC multiplexing	N/A	Yes	
Layer 1	TrCH type	DCH	DCH	
	Transport Channel Identity	1	5	
	TB sizes, bit	2880	100	
	TFS	TF0, bits	0*2880	0*100
		TF1, bits	1*2880	1*100
	TTI, ms	20	40	
	Coding type	Turbo Coding	Convolution Coding	
	Coding Rate	N/A	1/3	
	CRC, bit	16	12	
	Max number of bits/TTI after channel coding	8700	360	
	Uplink: Max number of bits/radio frame before rate matching	4350	90	
	RM attribute	256	256	

Table C.2.3.3: UL reference measurement channel using RLC-AM for DTCH, transport channel parameters (144 kbps)

Higher Layer	RAB/Signalling RB	RAB	SRB	
RLC	Logical channel type	DTCH	DCCH	
	RLC mode	AM	UM/AM	
	Payload sizes, bit	2864	88/80	
	Max data rate, bps	143200	2200/2000	
	PDU header, bit	16	8/16	
	TrD PDU header, bit	N/A	N/A	
MAC	MAC header, bit	0	4	
	MAC multiplexing	N/A	Yes	
Layer 1	TrCH type	DCH	DCH	
	Transport Channel Identity	1	5	
	TB sizes, bit	2880	100	
	TFS	TF0, bits	0*2880	0*100
		TF1, bits	1*2880	1*100
	TTI, ms	20	40	
	Coding type	Turbo Coding	Convolution Coding	
	Coding Rate	N/A	1/3	
	CRC, bit	16	12	
	Max number of bits/TTI after channel coding	8700	360	
	Uplink: Max number of bits/radio frame before rate matching	4350	90	
	RM attribute	256	256	

Table C.2.3.4: UL reference measurement channel, TFCS (144 kbps)

TFCS size	4
TFCS	(DTCH, DCCH)= (TF0, TF0), (TF1, TF0), (TF0, TF1), (TF1, TF1)

NOTE: The TFCs except for (TF1, TF1) are belonging to minimum set of TFCs.

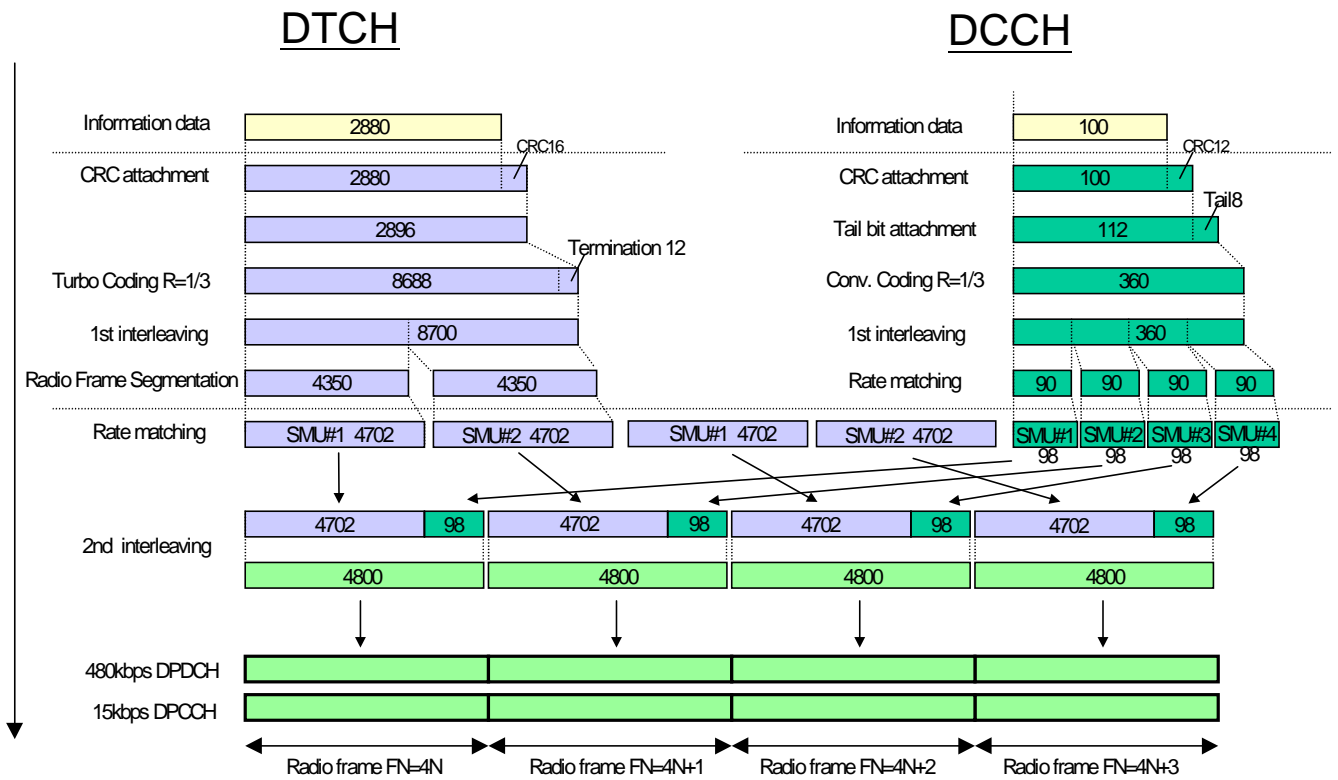

Figure C.2.3 (Informative): Channel coding of UL reference measurement channel (144 kbps)

C.2.4 UL reference measurement channel (384 kbps)

The parameters for the 384 kbps UL reference measurement channel are specified in table C.2.4.1, table C.2.4.2, table C.2.4.3 and table C.2.4.4. The channel coding for information is shown in figure C.2.4. When the UE test loop function is needed, the UE test loop mode 2 shall be used. This measurement channel is not currently used in the present document but can be used for future requirements.

Table C.2.4.1: UL reference measurement channel (384 kbps)

Parameter	Level	Unit
Information bit rate	384	kbps
DPDCH	960	kbps
DPCCH	15	kbps
DPCCH Slot Format #i	0	-
DPCCH/DPDCH power ratio	-11,48	dB
TFCI	On	-
Puncturing	18	%

Table C.2.4.2: UL reference measurement channel using RLC-TM for DTCH, transport channel parameters (384 kbps)

Higher Layer	RAB/Signalling RB	RAB	SRB	
RLC	Logical channel type	DTCH	DCCH	
	RLC mode	TM	UM/AM	
	Payload sizes, bit	3840	88/80	
	Max data rate, bps	384000	2200/2000	
	PDU header, bit	N/A	8/16	
	TrD PDU header, bit	0	N/A	
MAC	MAC header, bit	0	4	
	MAC multiplexing	N/A	Yes	
Layer 1	TrCH type	DCH	DCH	
	Transport Channel Identity	1	5	
	TB sizes, bit	3840	100	
	TFS	TF0, bits	0*3840	0*100
		TF1, bits	1*3840	1*100
	TTI, ms	10	40	
	Coding type	Turbo Coding	Convolution Coding	
	Coding Rate	N/A	1/3	
	CRC, bit	16	12	
	Max number of bits/TTI after channel coding	11580	360	
	Uplink: Max number of bits/radio frame before rate matching	11580	90	
	RM attribute	256	256	

Table C.2.4.3: UL reference measurement channel using RLC-AM for DTCH, transport channel parameters (384 kbps)

Higher Layer	RAB/Signalling RB	RAB	SRB	
RLC	Logical channel type	DTCH	DCCH	
	RLC mode	AM	UM/AM	
	Payload sizes, bit	3824	88/80	
	Max data rate, bps	382400	2200/2000	
	PDU header, bit	16	8/16	
	TrD PDU header, bit	N/A	N/A	
MAC	MAC header, bit	0	4	
	MAC multiplexing	N/A	Yes	
Layer 1	TrCH type	DCH	DCH	
	Transport Channel Identity	1	5	
	TB sizes, bit	3840	100	
	TFS	TF0, bits	0*3840	0*100
		TF1, bits	1*3840	1*100
	TTI, ms	10	40	
	Coding type	Turbo Coding	Convolution Coding	
	Coding Rate	N/A	1/3	
	CRC, bit	16	12	
	Max number of bits/TTI after channel coding	11580	360	
	Uplink: Max number of bits/radio frame before rate matching	11580	90	
	RM attribute	256	256	

Table C.2.4.4: UL reference measurement channel, TFCS (384 kbps)

TFCS size	4
TFCS	(DTCH, DCCH)= (TF0, TF0), (TF1, TF0), (TF0, TF1), (TF1, TF1)

NOTE: The TFCs except for (TF1, TF1) are belonging to minimum set of TFCs.

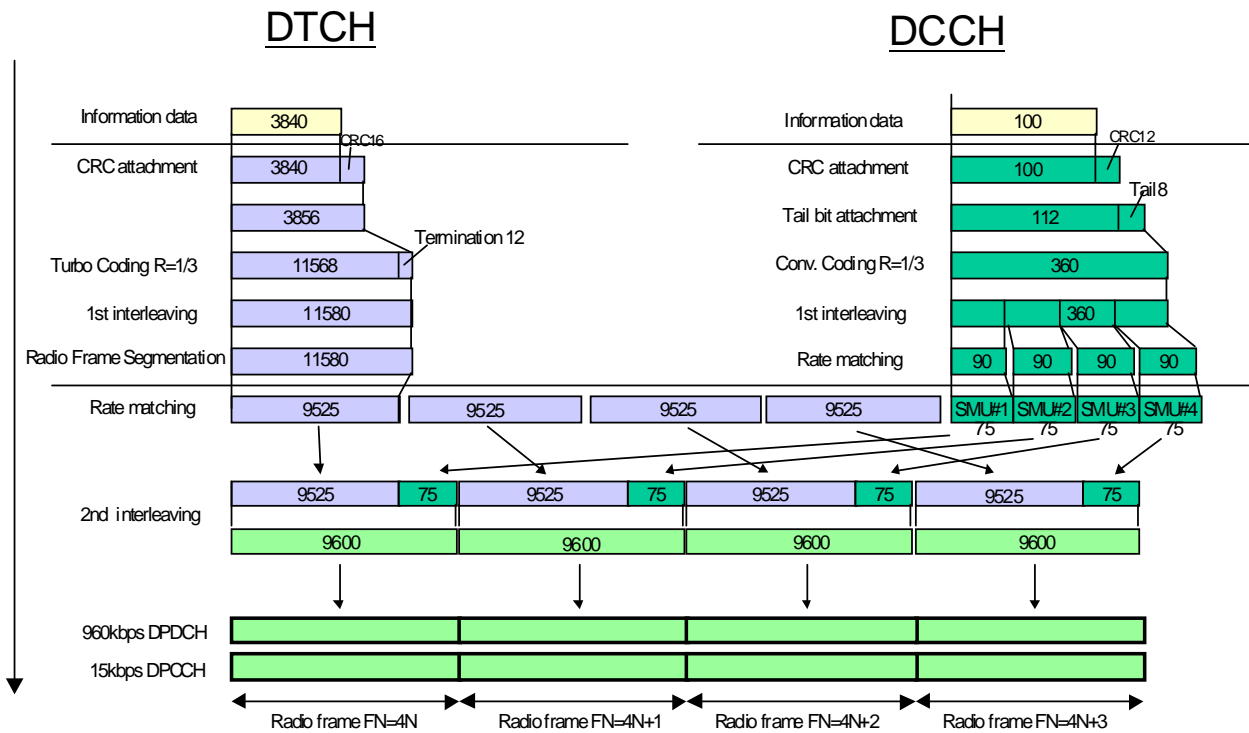

Figure C.2.4 (informative): Channel coding of UL reference measurement channel (384 kbps)

C.2.5 UL reference measurement channel (768 kbps)

The parameters for the UL measurement channel for 768 kbps are specified in table C.2.5.1, table C.2.5.2, table C.2.5.3 and table C.2.5.4. When the UE test loop function is needed, the UE test loop mode 2 shall be used.

Table C.2.5.1: UL reference measurement channel, physical parameters (768 kbps)

Parameter	Level	Unit
Information bit rate	2*384	kbps
DPDCH ₁	960	kbps
DPDCH ₂	960	kbps
DPCCH	15	kbps
DPCCH Slot Format #i	0	-
DPCCH/DPDCH power ratio	-11.48	dB
TFCI	On	-
Puncturing	18	%

Table C.2.5.2: UL reference measurement channel using RLC-TM for DTCH, transport channel parameters (768 kbps)

Higher Layer	RAB/Signalling RB	RAB	SRB	
RLC	Logical channel type	DTCH	DCCH	
	RLC mode	TM	UM/AM	
	Payload sizes, bit	7680	88/80	
	Max data rate, bps	768000	2200/2000	
	PDU header, bit	N/A	8/16	
	TrD PDU header, bit	0	N/A	
MAC	MAC header, bit	0	4	
	MAC multiplexing	N/A	Yes	
Layer 1	TrCH type	DCH	DCH	
	Transport Channel Identity	1	5	
	TB sizes, bit	3840	100	
	TFS	TF0, bits	0*3840	0*100
		TF1, bits	2*3840	1*100
	TTI, ms	10	40	
	Coding type	Turbo Coding	Convolution Coding	
	Coding Rate	N/A	1/3	
	CRC, bit	16	12	
	Max number of bits/TTI after channel coding	23160	360	
	Uplink: Max number of bits/radio frame before rate matching	23160	90	
	RM attribute	256	256	

Table C.2.5.3: UL reference measurement channel using RLC-AM for DTCH, transport channel parameters (768 kbps)

Higher Layer	RAB/Signalling RB	RAB	SRB	
RLC	Logical channel type	DTCH	DCCH	
	RLC mode	TM	UM/AM	
	Payload sizes, bit	7664	88/80	
	Max data rate, bps	766400	2200/2000	
	PDU header, bit	16	8/16	
	TrD PDU header, bit	N/A	N/A	
MAC	MAC header, bit	0	4	
	MAC multiplexing	N/A	Yes	
Layer 1	TrCH type	DCH	DCH	
	Transport Channel Identity	1	5	
	TB sizes, bit	3840	100	
	TFS	TF0, bits	0*3840	0*100
		TF1, bits	2*3840	1*100
	TTI, ms	10	40	
	Coding type	Turbo Coding	Convolution Coding	
	Coding Rate	N/A	1/3	
	CRC, bit	16	12	
	Max number of bits/TTI after channel coding	23160	360	
	Uplink: Max number of bits/radio frame before rate matching	23160	90	
	RM attribute	256	256	

Table C.2.5.4: UL reference measurement channel, TFCS (768 kbps)

TFCS size	4
TFCS	(DTCH, DCCH)= (TF0, TF0), (TF1, TF0), (TF0, TF1), (TF1, TF1)

NOTE: The TFCs except for (TF1, TF1) are belonging to minimum set of TFCs.

C.3 DL reference measurement channel

C.3.1 DL reference measurement channel (12.2 kbps)

The parameters for the 12,2 kbps DL reference measurement channel are specified in table C.3.1.1, table C.3.1.2, table C.3.1.3 and table C.3.1.4. The channel coding is detailed in figure C.3.1. For the RLC configuration of AM DCCHs Timer_STATUS_Periodic shall not be set in RRC CONNECTION SETUP message used in test procedure for RF test as defined in TS34.108 clause 7.3. This is to prevent unexpected DCHs from being transmitted through such RLC entities when the timer has expired in order to sure that the required TFC from the minimum set of TFCs can continuously convey a DCH for DTCH during the test.

Table C.3.1.1: DL reference measurement channel (12.2 kbps)

Parameter	Level	Unit
Information bit rate	12.2	kbps
DPCH	30	ksps
Slot Format #1	11	-
TFCI	On	
Power offsets PO1, PO2 and PO3	0	dB
DTX position	Fixed	-

Table C.3.1.2: DL reference measurement channel using RLC-TM for DTCH, transport channel parameters (12.2 kbps)

Higher Layer	RAB/Signalling RB	RAB	SRB	
RLC	Logical channel type	DTCH	DCCH	
	RLC mode	TM	UM/AM	
	Payload sizes, bit	244	88/80	
	Max data rate, bps	12200	2200/2000	
	PDU header, bit	N/A	8/16	
	TrD PDU header, bit	0	N/A	
MAC	MAC header, bit	0	4	
	MAC multiplexing	N/A	Yes	
Layer 1	TrCH type	DCH	DCH	
	Transport Channel Identity	6	10	
	TB sizes, bit	244	100	
	TFS	TF0, bits	0*244	0*100
		TF1, bits	1*244	1*100
	TTI, ms	20	40	
	Coding type	Convolution Coding	Convolution Coding	
	Coding Rate	1/3	1/3	
	CRC, bit	16	12	
	Max number of bits/TTI after channel coding	804	360	
RM attribute	256	256		

Table C.3.1.3: DL reference measurement channel using RLC-AM for DTCH, transport channel parameters (12.2 kbps)

Higher Layer	RAB/Signalling RB	RAB	SRB	
RLC	Logical channel type	DTCH	DCCH	
	RLC mode	AM	UM/AM	
	Payload sizes, bit	228	88/80	
	Max data rate, bps	11400	2200/2000	
	PDU header, bit	16	8/16	
	TrD PDU header, bit	N/A	N/A	
MAC	MAC header, bit	0	4	
	MAC multiplexing	N/A	Yes	
Layer 1	TrCH type	DCH	DCH	
	Transport Channel Identity	6	10	
	TB sizes, bit	244	100	
	TFS	TF0, bits	0*244	0*100
		TF1, bits	1*244	1*100
	TTI, ms	20	40	
	Coding type	Convolution Coding	Convolution Coding	
	Coding Rate	1/3	1/3	
	CRC, bit	16	12	
	Max number of bits/TTI after channel coding	804	360	
	RM attribute	256	256	

Table C.3.1.4: DL reference measurement channel, TFCS (12.2 kbps)

TFCS size	4
TFCS	(DTCH, DCCH)= (TF0, TF0), (TF1, TF0), (TF0, TF1), (TF1, TF1)

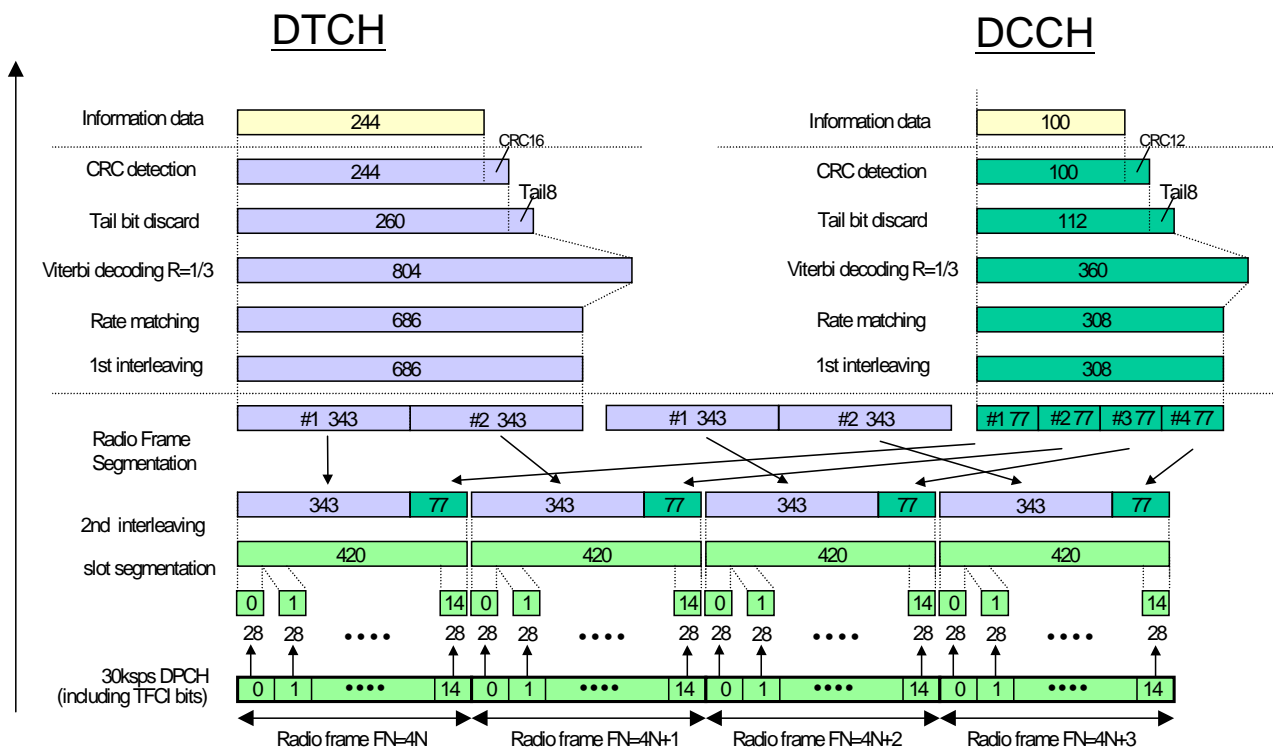

Figure C.3.1 (informative): Channel coding of DL reference measurement channel (12,2 kbps)

C.3.2 DL reference measurement channel (64 kbps)

The parameters for the DL reference measurement channel for 64 kbps are specified in table C.3.2.1, table C.3.2.2, table C.3.2.3 and table C.3.2.4. The channel coding is detailed in figure C.3.2. For the RLC configuration of AM DCCHs Timer_STATUS_Periodic shall not be set in RRC CONNECTION SETUP message used in test procedure for RF test as defined in TS34.108 clause 7.3. This is to prevent unexpected DCHs from being transmitted through such RLC entities when the timer has expired in order to sure that the required TFC from the minimum set of TFCs can continuously convey a DCH for DTCH during the test.

Table C.3.2.1: DL reference measurement channel (64 kbps)

Parameter	Level	Unit
Information bit rate	64	kbps
DPCH	120	ksps
Slot Format #i	13	-
TFCI	On	-
Power offsets PO1, PO2 and PO3	0	dB
DTX position	Fixed	-

Table C.3.2.2: DL reference measurement channel using RLC-TM for DTCH, transport channel parameters (64 kbps)

Higher Layer	RAB/Signalling RB	RAB	SRB	
RLC	Logical channel type	DTCH	DCCH	
	RLC mode	TM	UM/AM	
	Payload sizes, bit	1280	88/80	
	Max data rate, bps	64000	2200/2000	
	PDU header, bit	N/A	8/16	
	TrD PDU header, bit	0	N/A	
MAC	MAC header, bit	0	4	
	MAC multiplexing	N/A	Yes	
Layer 1	TrCH type	DCH	DCH	
	Transport Channel Identity	6	10	
	TB sizes, bit	1280	100	
	TFS	TF0, bits	0*1280	0*100
		TF1, bits	1*1280	1*100
	TTI, ms	20	40	
	Coding type	Turbo Coding	Convolution Coding	
	Coding Rate	N/A	1/3	
	CRC, bit	16	12	
	Max number of bits/TTI after channel coding	3900	360	
	RM attribute	256	256	

Table C.3.2.3: DL reference measurement channel using RLC-AM for DTCH, transport channel parameters (64 kbps)

Higher Layer	RAB/Signalling RB	RAB	SRB	
RLC	Logical channel type	DTCH	DCCH	
	RLC mode	AM	UM/AM	
	Payload sizes, bit	1264	88/80	
	Max data rate, bps	63200	2200/2000	
	PDU header, bit	16	8/16	
	TrD PDU header, bit	N/A	N/A	
MAC	MAC header, bit	0	4	
	MAC multiplexing	N/A	Yes	
Layer 1	TrCH type	DCH	DCH	
	Transport Channel Identity	6	10	
	TB sizes, bit	1280	100	
	TFS	TF0, bits	0*1280	0*100
		TF1, bits	1*1280	1*100
	TTI, ms	20	40	
	Coding type	Turbo Coding	Convolution Coding	
	Coding Rate	N/A	1/3	
	CRC, bit	16	12	
	Max number of bits/TTI after channel coding	3900	360	
	RM attribute	256	256	

Table C.3.2.4: DL reference measurement channel, TFCS (64 kbps)

TFCS size	4
TFCS	(DTCH, DCCH)= (TF0, TF0), (TF1, TF0), (TF0, TF1), (TF1, TF1)

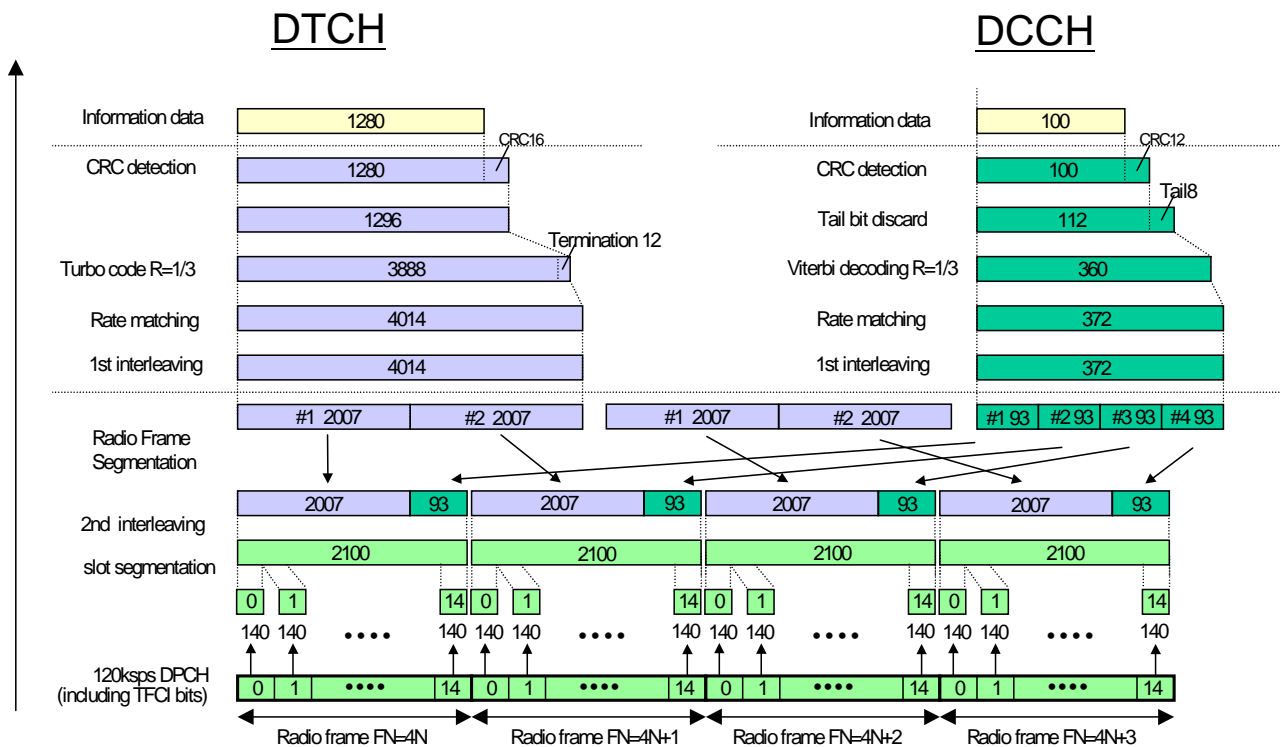

Figure C.3.2 (informative): Channel coding of DL reference measurement channel (64 kbps)

C.3.3 DL reference measurement channel (144 kbps)

The parameters for the DL reference measurement channel for 144 kbps are specified in table C.3.3.1, table C.3.3.2, table C.3.3.3 and table C.3.3.4. The channel coding is detailed in figure C.3.3. For the RLC configuration of AM DCCHs Timer_STATUS_Periodic shall not be set in RRC CONNECTION SETUP message used in test procedure for RF test as defined in TS34.108 clause 7.3. This is to prevent unexpected DCHs from being transmitted through such RLC entities when the timer has expired in order to sure that the required TFC from the minimum set of TFCs can continuously convey a DCH for DTCH during the test.

Table C.3.3.1: DL reference measurement channel (144kbps)

Parameter	Level	Unit
Information bit rate	144	kbps
DPCH	240	ksps
Slot Format #i	14	-
TFCI	On	
Power offsets PO1, PO2 and PO3	0	dB
DTX position	Fixed	-

Table C.3.3.2: DL reference measurement channel using RLC-TM for DTCH, transport channel parameters (144 kbps)

Higher Layer	RAB/Signalling RB	RAB	SRB	
RLC	Logical channel type	DTCH	DCCH	
	RLC mode	TM	UM/AM	
	Payload sizes, bit	2880	88/80	
	Max data rate, bps	144000	2200/2000	
	PDU header, bit	N/A	8/16	
	TrD PDU header, bit	0	N/A	
MAC	MAC header, bit	0	4	
	MAC multiplexing	N/A	Yes	
Layer 1	TrCH type	DCH	DCH	
	Transport Channel Identity	6	10	
	TB sizes, bit	2880	100	
	TFS	TF0, bits	0*2880	0*100
		TF1, bits	1*2880	1*100
	TTI, ms	20	40	
	Coding type	Turbo Coding	Convolution Coding	
	Coding Rate	N/A	1/3	
	CRC, bit	16	12	
	Max number of bits/TTI after channel coding	8700	360	
	RM attribute	256	256	

Table C.3.3.3: DL reference measurement channel using RLC-AM for DTCH, transport channel parameters (144 kbps)

Higher Layer	RAB/Signalling RB	RAB	SRB	
RLC	Logical channel type	DTCH	DCCH	
	RLC mode	AM	UM/AM	
	Payload sizes, bit	2864	88/80	
	Max data rate, bps	143200	2200/2000	
	PDU header, bit	16	8/16	
	TrD PDU header, bit	N/A	N/A	
MAC	MAC header, bit	0	4	
	MAC multiplexing	N/A	Yes	
Layer 1	TrCH type	DCH	DCH	
	Transport Channel Identity	6	10	
	TB sizes, bit	2880	100	
	TFS	TF0, bits	0*2880	0*100
		TF1, bits	1*2880	1*100
	TTI, ms	20	40	
	Coding type	Turbo Coding	Convolution Coding	
	Coding Rate	N/A	1/3	
	CRC, bit	16	12	
	Max number of bits/TTI after channel coding	8700	360	
	RM attribute	256	256	

Table C.3.3.4: DL reference measurement channel, TFCS (144 kbps)

TFCS size	4
TFCS	(DTCH, DCCH)= (TF0, TF0), (TF1, TF0), (TF0, TF1), (TF1, TF1)

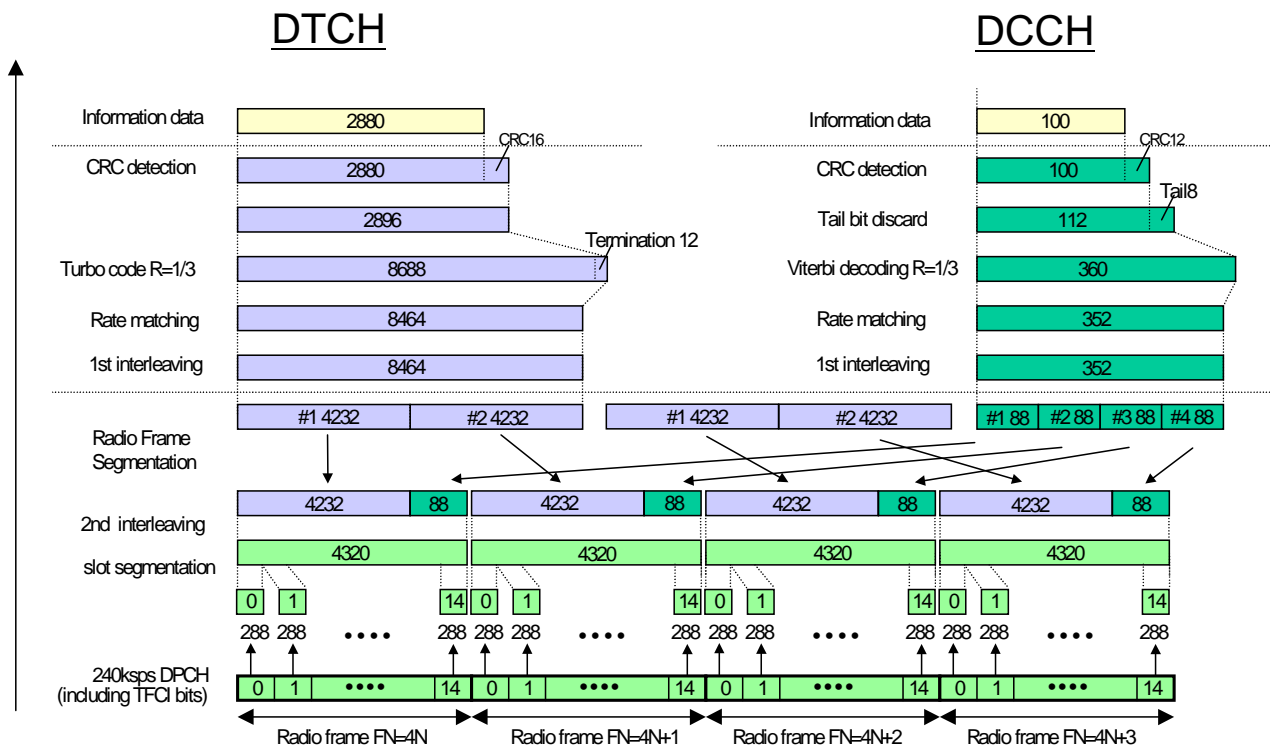

Figure C.3.3 (informative): Channel coding of DL reference measurement channel (144 kbps)

C.3.4 DL reference measurement channel (384 kbps)

The parameters for the DL reference measurement channel for 384 kbps are specified in table C.3.4.1, table C.3.4.2, table C.3.4.3 and table C.3.4.4. The channel coding is shown for information in figure C3.4. For the RLC configuration of AM DCCHs Timer_STATUS_Periodic shall not be set in RRC CONNECTION SETUP message used in test procedure for RF test as defined in TS34.108 clause 7.3. This is to prevent unexpected DCHs from being transmitted through such RLC entities when the timer has expired in order to sure that the required TFC from the minimum set of TFCs can continuously convey a DCH for DTCH during the test.

Table C.3.4.1: DL reference measurement channel, physical parameters (384 kbps)

Parameter	Level	Unit
Information bit rate	384	kbps
DPCH	480	ksps
Slot Format #i	15	-
TFCI	On	-
Power offsets PO1, PO2 and PO3	0	dB
DTX position	Fixed	-

Table C.3.4.2: DL reference measurement channel using RLC-TM for DTCH, transport channel parameters (384 kbps)

Higher Layer	RAB/Signalling RB	RAB	SRB	
RLC	Logical channel type	DTCH	DCCH	
	RLC mode	TM	UM/AM	
	Payload sizes, bit	3840	88/80	
	Max data rate, bps	384000	2200/2000	
	PDU header, bit	N/A	8/16	
	TrD PDU header, bit	0	N/A	
MAC	MAC header, bit	0	4	
	MAC multiplexing	N/A	Yes	
Layer 1	TrCH type	DCH	DCH	
	Transport Channel Identity	6	10	
	TB sizes, bit	3840	100	
	TFS	TF0, bits	0*3840	0*100
		TF1, bits	1*3840	1*100
	TTI, ms	10	40	
	Coding type	Turbo Coding	Convolution Coding	
	Coding Rate	N/A	1/3	
	CRC, bit	16	12	
	Max number of bits/TTI after channel coding	11580	360	
	RM attribute	256	256	

Table C.3.4.3: DL reference measurement channel using RLC-AM for DTCH, transport channel parameters (384 kbps)

Higher Layer	RAB/Signalling RB	RAB	SRB	
RLC	Logical channel type	DTCH	DCCH	
	RLC mode	AM	UM/AM	
	Payload sizes, bit	3824	88/80	
	Max data rate, bps	382400	2200/2000	
	PDU header, bit	16	8/16	
	TrD PDU header, bit	N/A	N/A	
MAC	MAC header, bit	0	4	
	MAC multiplexing	N/A	Yes	
Layer 1	TrCH type	DCH	DCH	
	Transport Channel Identity	6	10	
	TB sizes, bit	3840	100	
	TFS	TF0, bits	0*3840	0*100
		TF1, bits	1*3840	1*100
	TTI, ms	10	40	
	Coding type	Turbo Coding	Convolution Coding	
	Coding Rate	N/A	1/3	
	CRC, bit	16	12	
	Max number of bits/TTI after channel coding	11580	360	
	RM attribute	256	256	

Table C.3.4.4: DL reference measurement channel, TFCS (384 kbps)

TFCS size	4
TFCS	(DTCH, DCCH)= (TF0, TF0), (TF1, TF0), (TF0, TF1), (TF1, TF1)

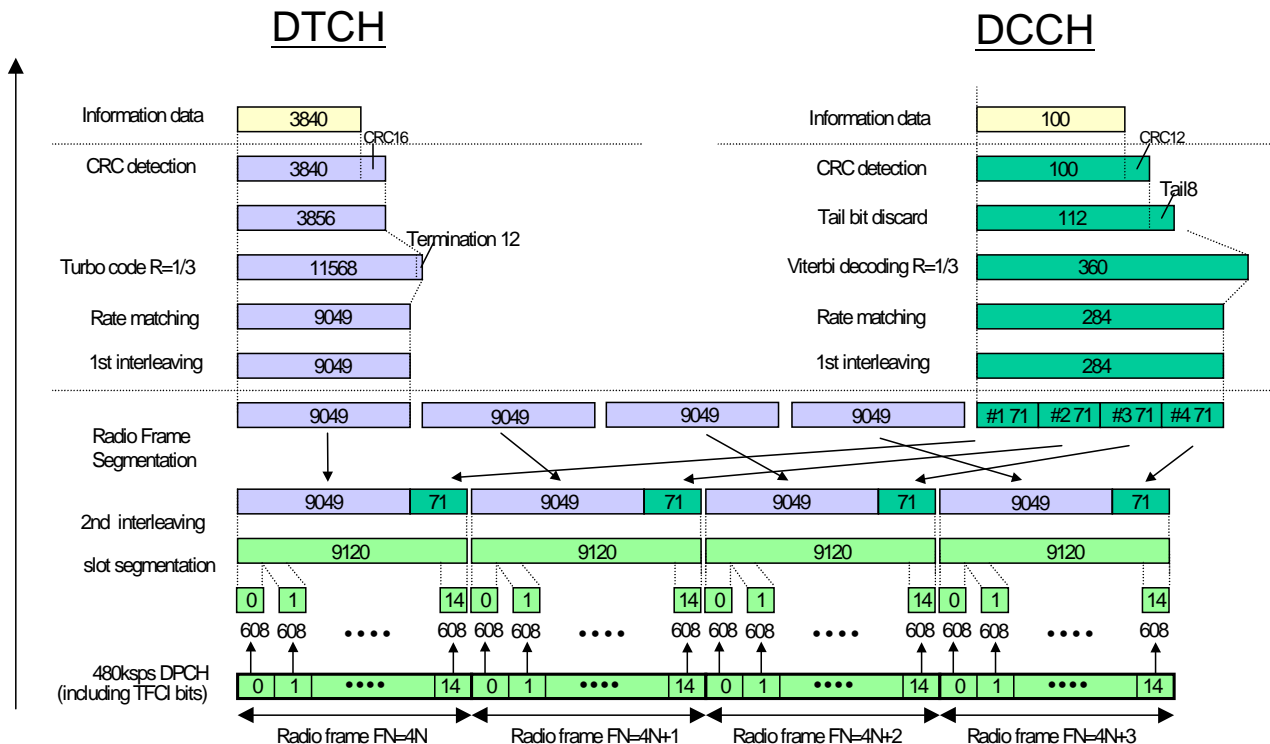

Figure C.3.4 (informative): Channel coding of DL reference measurement channel (384 kbps)

C.4 Reference measurement channel for BTFD performance requirements

C.4.1 UL reference measurement channel for BTFD performance requirements

The parameters for UL reference measurement channel for BTFD are specified in table C.4.1.1, table C.4.1.2, table C.4.1.3 and table C.4.1.4.

Table C.4.1.1: UL reference measurement channel physical parameters for BTFD

Parameter	Level	Unit
Information bit rate	12.8k, 10.8k, 8.55k, 8.0k, 7.3k, 6.5k, 5.75k, 5.35k, 2.55k	kbps
DPCCH	15	kbps
DPCCH Slot Format #1	0	-
DPCCH/DPDCH power ratio	-5.46 (12.8k - 7.3k)	dB
	-2.69 (6.5k – 2.55k)	
TFCI	On	-
Puncturing Limit	100	%

Table C.4.1.2: UL reference measurement channel, transport channel parameters for SRB

Higher Layer	RAB/Signalling RB	SRB	
RLC	Logical channel type	DCCH	
	RLC mode	UM/AM	
	Payload sizes, bit	88/80	
	Max data rate, bps	2200/2000	
	PDU header, bit	8/16	
	TrD PDU header, bit	N/A	
MAC	MAC header, bit	4	
	MAC multiplexing	Yes	
Layer 1	TrCH type	DCH	
	Transport Channel Identity	10	
	TB sizes, bit	100	
	TFS	TF0, bits	0*100
		TF1, bits	1*100
	TTI, ms	40	
	Coding type	Convolution Coding	
	Coding Rate	1/3	
	CRC, bit	12	
	Max number of bits/TTI after channel coding	360	
	Uplink: Max number of bits/radio frame before rate matching	90	
	RM attribute	256	

Table C.4.1.3: UL reference measurement channel using RLC-TM for DTCH, transport channel parameters

Higher Layer	RAB/Signalling RB	12.8k /10.8k/8.55k/8.0k/7.3k/6.5k/5.75k/5.35k/2.55k	
RLC	Logical channel type	DTCH	
	RLC mode	TM	
	Payload sizes, bit	256, 216, 171, 160, 146, 130, 115, 107, 51, 12	
	Max data rate, bps	12200	
	PDU header, bit	N/A	
	TrD PDU header, bit	0	
MAC	MAC header, bit	0	
	MAC multiplexing	N/A	
Layer 1	TrCH type	DCH	
	Transport Channel Identity	1	
	TB sizes, bit	256, 216, 171, 160, 146, 130, 115, 107, 51,12	
	TFS	TF0 bit	0x256
		TF1 bit	1x256
		TF2 bit	1x216
		TF3 bit	1x171
		TF4 bit	1x160
		TF5 bit	1x146
		TF6 bit	1x130
		TF7 bit	1x115
		TF8 bit	1x107
		TF9 bit	1x51
	TF10 bit	1x12	
	TTI, ms	20	
Coding type	CC		
Coding Rate	1/3		
CRC, bit	0		
RM attribute	256		

Table C.4.1.4: UL reference measurement channel, TFCS

TFCS size	22
TFCS	(DTCH, DCCH)= (TF0, TF0), (TF1, TF0), (TF2, TF0), (TF3, TF0), (TF4, TF0), (TF5, TF0), (TF6, TF0), (TF7, TF0), (TF8, TF0), (TF9, TF0), (TF10, TF0), (TF0, TF1), (TF1, TF1), (TF2, TF1), (TF3, TF1), (TF4, TF1), (TF5, TF1), (TF6, TF1), (TF7, TF1), (TF8, TF1), (TF9, TF1), (TF10, TF1)

NOTE: The TFCs except for (TF1, TF1), (TF2, TF1), (TF3, TF1), (TF4, TF1), (TF5, TF1), (TF6, TF1), (TF7, TF1), (TF8, TF1), (TF9, TF1) and (TF10, TF1) are belonging to minimum set of TFCs.

C.4.2 DL reference measurement channel for BTFD performance requirements

The parameters for DL reference measurement channel for BTFD are specified in table C.4.2.1, table C.4.2.2, table C.4.2.3 and table C.4.2.4. The channel coding for information is shown in figures C.4.1, C.4.2, and C.4.3. For the RLC configuration of AM DCCHs Timer_STATUS_Periodic shall not be set in RRC CONNECTION SETUP message used in test procedure for RF test as defined in TS34.108 clause 7.3. This is to prevent unexpected DCHs from being transmitted through such RLC entities when the timer has expired in order to sure that the required TFC from the minimum set of TFCs can continuously convey a DCH for DTCH during the test.

Table C.4.2.1: DL reference measurement channel physical parameters for BTFD

Parameter	Rate 1	Rate 2	Rate 3	Unit
Information bit rate	12,2	7,95	1,95	kbps
DPCH	30			ksps
Slot Format #1	8			-
TFCI	Off			-
Power offsets PO1, PO2 and PO3	0			dB
DTX position	Fixed			-

Table C.4.2.2: DL reference measurement channel, transport channel parameters for SRB

Higher Layer	RAB/Signalling RB	SRB	
RLC	Logical channel type	DCCH	
	RLC mode	UM/AM	
	Payload sizes, bit	88/80	
	Max data rate, bps	2200/2000	
	PDU header, bit	8/16	
	TrD PDU header, bit	N/A	
MAC	MAC header, bit	4	
	MAC multiplexing	Yes	
Layer 1	TrCH type	DCH	
	Transport Channel Identity	20	
	TB sizes, bit	100	
	TFS	TF0, bits	0*100
		TF1, bits	1*100
	TTI, ms	40	
	Coding type	Convolution Coding	
	Coding Rate	1/3	
	CRC, bit	12	
	Max number of bits/TTI after channel coding	360	
	Uplink: Max number of bits/radio frame before rate matching	90	
	RM attribute	256	

Table C.4.2.3: DL reference measurement channel using RLC-TM for DTCH, transport channel parameters

Higher Layer	RAB/Signalling RB	12.2k/10.2k/7.95k/7.4k/6.7k/5.9k/5.15k/4.75k/1.95k	
RLC	Logical channel type	DTCH	
	RLC mode	TM	
	Payload sizes, bit	244, 204, 159, 148, 134, 118, 103, 95, 39	
	Max data rate, bps	12200	
	PDU header, bit	N/A	
	TrD PDU header, bit	0	
MAC	MAC header, bit	0	
	MAC multiplexing	N/A	
Layer 1	TrCH type	DCH	
	Transport Channel Identity	1	
	TB sizes, bit	244, 204, 159, 148, 134, 118, 103, 95, 39,0	
	TFS	TF0 bit	1x0
		TF1 bit	1x244
		TF2 bit	1x204
		TF3 bit	1x159
		TF4 bit	1x148
		TF5 bit	1x134
		TF6 bit	1x118
		TF7 bit	1x103
		TF8 bit	1x95
		TF9 bit	1x39
	TTI, ms	20	
Coding type	CC		
Coding Rate	1/3		
CRC, bit	0		
RM attribute	256		

Table C.4.2.4: DL reference measurement channel, TFCS

TFCS size	20
TFCS	(DTCH, DCCH)= (TF0, TF0), (TF1, TF0), (TF2, TF0), (TF3, TF0), (TF4, TF0), (TF5, TF0), (TF6, TF0), (TF7, TF0), (TF8, TF0), (TF9, TF0), (TF0, TF1), (TF1, TF1), (TF2, TF1), (TF3, TF1), (TF4, TF1), (TF5, TF1), (TF6, TF1), (TF7, TF1), (TF8, TF1), (TF9, TF1),

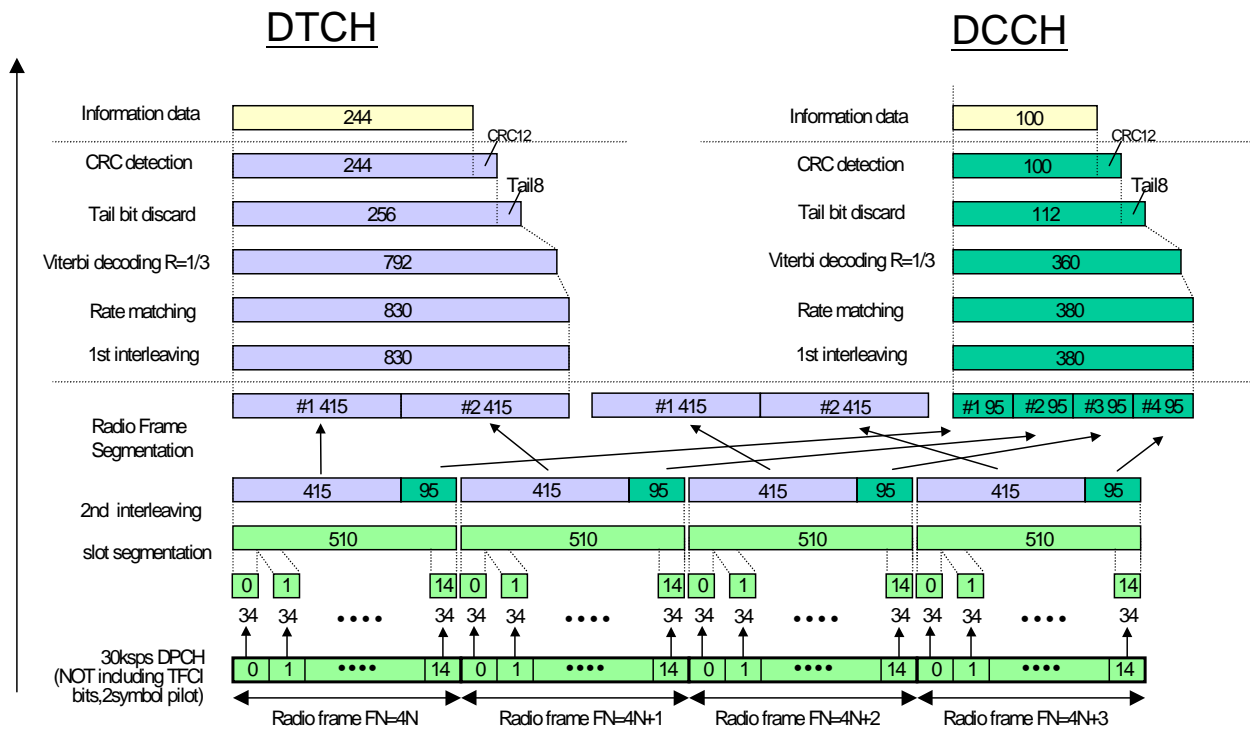

Figure C.4.1 (informative): Channel coding of DL reference measurement channel for BTFD (Rate 1)

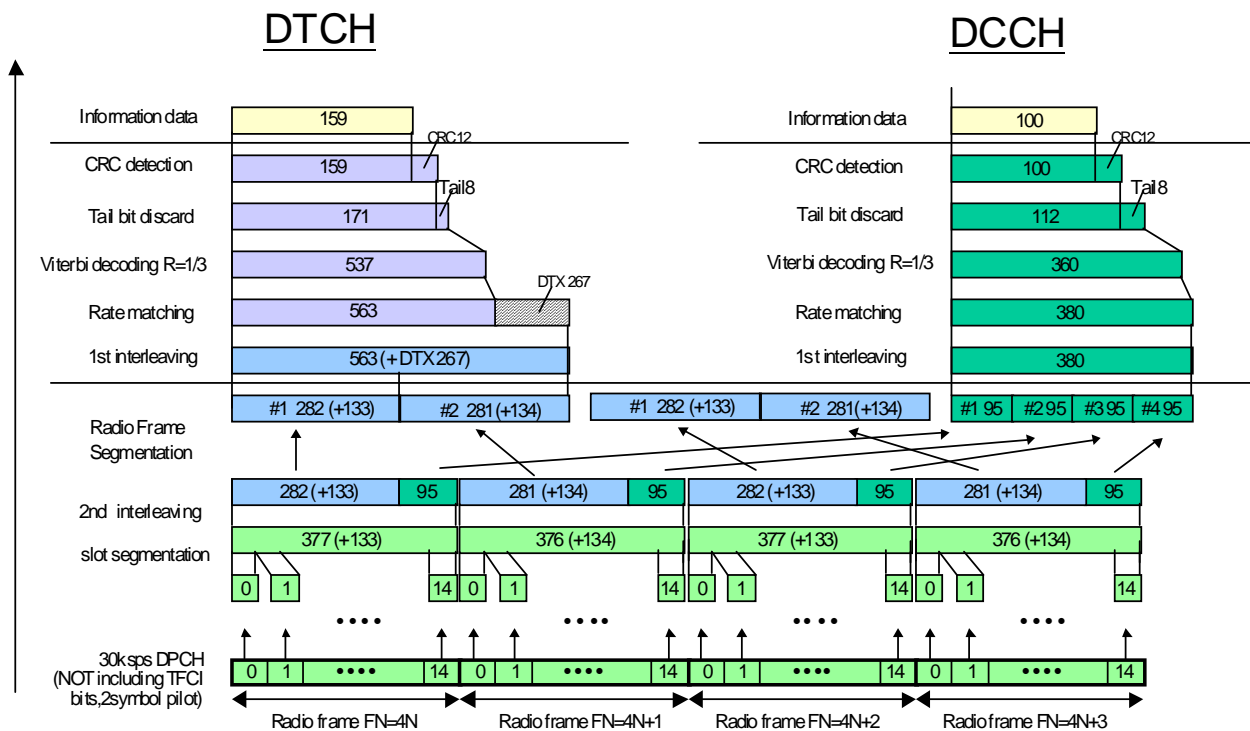

Figure C.4.2 (informative): Channel coding of DL reference measurement channel for BTFD (Rate 2)

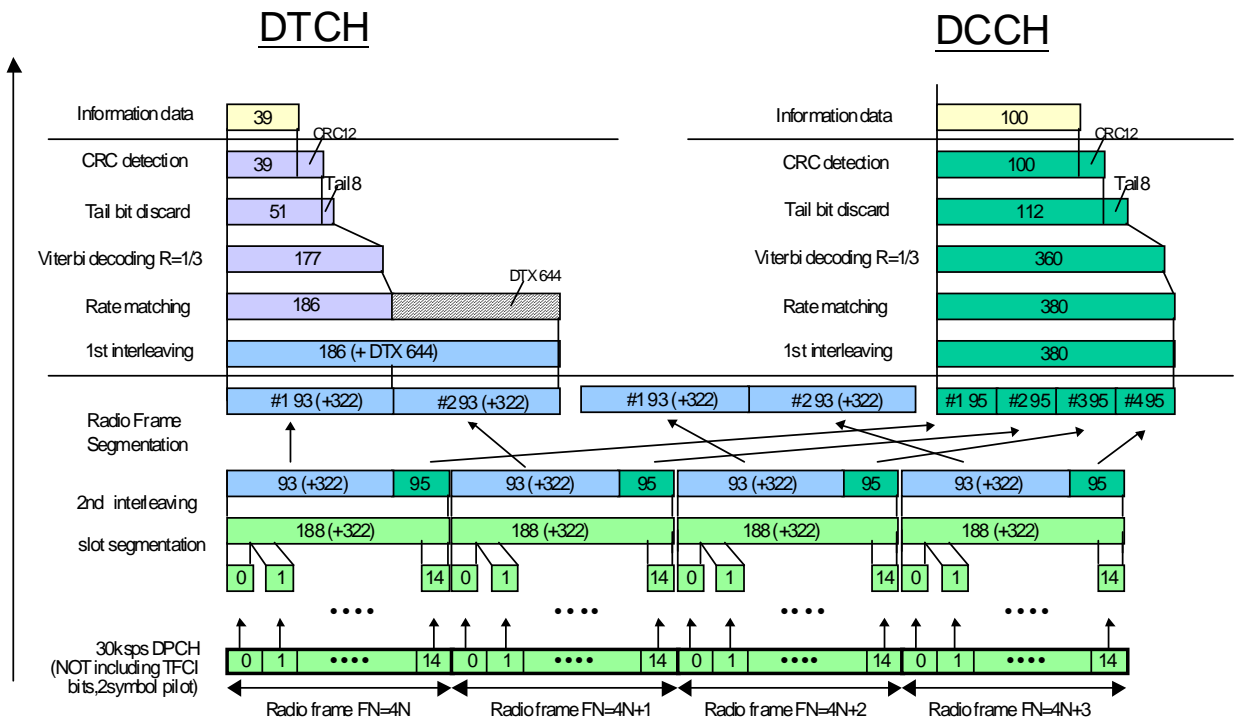

Figure C.4.3 (informative): Channel coding of DL reference measurement channel for BTFD (Rate 3)

C.5 DL reference compressed mode parameters

Parameters described in table C.5.1 are used in some test specified in TS 25.101 while parameters described in table C.5.2 are used in some tests specified in TS 25.133.

Set 1 parameters in table C.5.1 are applicable when compressed mode by spreading factor reduction is used in downlink. Set 2 parameters in table C.5.1 are applicable when compressed mode by puncturing is used in downlink.

Table C.5.1: Compressed mode reference pattern 1 parameters

Parameter	Set 1	Set 2	Note
TGSN (Transmission Gap Starting Slot Number)	11	11	
TGL1 (Transmission Gap Length 1)	7	7	
TGL2 (Transmission Gap Length 2)	-	-	Only one gap in use.
TGD (Transmission Gap Distance)	0	0	Only one gap in use.
TGPL1 (Transmission Gap Pattern Length)	4	4	
TGPL2 (Transmission Gap Pattern Length)	-	-	Only one pattern in use.
TGPRC (Transmission Gap Pattern Repetition Count)	NA	NA	Defined by higher layers
TGCFN (Transmission Gap Connection Frame Number):	NA	NA	Defined by higher layers
UL/DL compressed mode selection	DL & UL	DL & UL	2 configurations possible DL &UL / DL
UL compressed mode method	SF/2	SF/2	
DL compressed mode method	SF/2	Puncturing	
Downlink frame type and Slot format	11B	11A	
Scrambling code change	No	No	
RPP (Recovery period power control mode)	0	0	
ITP (Initial transmission power control mode)	0	0	

Table C.5.2: Compressed mode reference pattern 2 parameters

Parameter	Set 1	Set 2	Set 3	Note
TGSN (Transmission Gap Starting Slot Number)	4	4	10	
TGL1 (Transmission Gap Length 1)	7	7	10	
TGL2 (Transmission Gap Length 2)	-	-	-	Only one gap in use.
TGD (Transmission Gap Distance)	0	0	0	
TGPL1 (Transmission Gap Pattern Length)	3	12	11	
TGPL2 (Transmission Gap Pattern Length)	-	-	-	Only one pattern in use.
TGPRC (Transmission Gap Pattern Repetition Count)	NA	NA	NA	Defined by higher layers
TGCFN (Transmission Gap Connection Frame Number):	NA	NA	NA	Defined by higher layers
UL/DL compressed mode selection	DL & UL	DL & UL	DL & UL	2 configurations possible. DL & UL / DL
UL compressed mode method	SF/2	SF/2	SF/2	
DL compressed mode method	SF/2	SF/2	Puncturing	
Downlink frame type and Slot format	11B	11B	11A	
Scrambling code change	No	No	No	
RPP (Recovery period power control mode)	0	0	0	
ITP (Initial transmission power control mode)	0	0	0	

Annex D (normative): Propagation Conditions

D.1 General

D.2 Propagation Conditions

D.2.1 Static propagation condition

The propagation for the static performance measurement is an Additive White Gaussian Noise (AWGN) environment. No fading and multi-paths exist for this propagation model.

D.2.2 Multi-path fading propagation conditions

Table D.2.2.1 shows propagation conditions that are used for the performance measurements in multi-path fading environment. All taps have classical Doppler spectrum.

Table D.2.2.1: Propagation conditions for multi-path fading environments

Case 1, speed 3km/h		Case 2, speed 3 km/h		Case 3, speed 120 km/h		Case 4, speed 3 km/h		* Case 5, speed 50 km/h		Case 6, speed 250 km/h	
Relative Delay [ns]	Average Power [dB]	Relative Delay [ns]	Average Power [dB]	Relative Delay [ns]	Average Power [dB]	Relative Delay [ns]	Average Power [dB]	Relative Delay [ns]	Average Power [dB]	Relative Delay [ns]	Average Power [dB]
0	0	0	0	0	0	0	0	0	0	0	0
976	-10	976	0	260	-3	976	0	976	-10	260	-3
		20000	0	521	-6					521	-6
				781	-9					781	-9

NOTE: Case 5 is only used in Requirements for support of RRM.

D.2.3 Moving propagation conditions

The dynamic propagation conditions for the test of the baseband performance are non fading channel models with two taps. The moving propagation condition has two taps, one static, Path0, and one moving, Path1. The time difference between the two paths is according Equation D.2.3.1. The taps have equal strengths and equal phases.

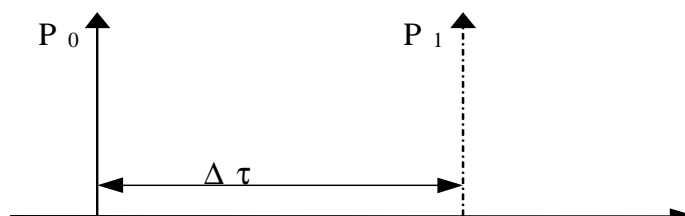

Figure D.2.3.1: The moving propagation conditions

$$\Delta\tau = B + \frac{A}{2}(1 + \sin(\Delta\omega \cdot t))$$

Equation D.2.3.1

The parameters in the equation are shown in.

A	5 μs
B	1 μs
$\Delta\omega$	$40 \cdot 10^{-3} \text{ s}^{-1}$

D.2.4 Birth-Death propagation conditions

The dynamic propagation conditions for the test of the baseband performance is a non fading propagation channel with two taps. The moving propagation condition has two taps, Path1 and Path2 while alternate between 'birth' and 'death'. The positions the paths appear are randomly selected with an equal probability rate and are shown in figure D.2.4.1.

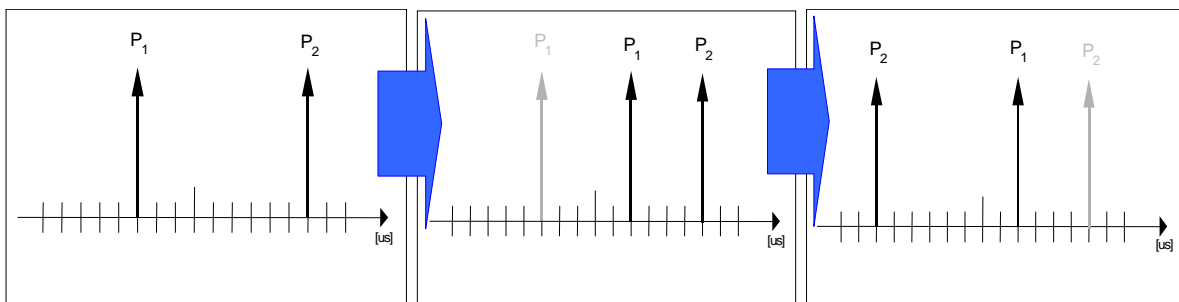

Figure D.2.4.1: Birth death propagation sequence

NOTE1: Two paths, Path1 and Path2 are randomly selected from the group [-5, -4, -3, -2, -1, 0, 1, 2, 3, 4, 5] μs . The paths have equal strengths and equal phases.

NOTE 2: After 191 ms, Path1 vanishes and reappears immediately at a new location randomly selected from the group [-5, -4, -3, -2, -1, 0, 1, 2, 3, 4, 5] μs but excludes the point Path2.

NOTE 3: After additional 191 ms, Path2 vanishes and reappears immediately at a new location randomly selected from the group [-5, -4, -3, -2, -1, 0, 1, 2, 3, 4, 5] μs but excludes the point Path1.

NOTE 4: The sequence in 2) and 3) is repeated.

Annex E (normative): Downlink Physical Channels

E.1 General

This normative annex specifies the downlink physical channels that are needed for setting a connection and channels that are needed during a connection.

E.2 Connection Set-up

Table E.2.1 describes the downlink Physical Channels that are required for connection set up.

Table E.2.1: Downlink Physical Channels required for connection set-up

Physical Channel
CPICH
P-CCPCH
SCH
S-CCPCH
PICH
AICH
DPCH

E.2.1 Measurement without dedicated connection

Table E.2.2 describes the downlink Physical Channels that are required for measurement before connection. This is applicable for the clauses 5.4.1 and 5.5.2.

Table E.2.2: Downlink Physical Channels transmitted without dedicated connection

Physical Channel	Power
I _{or}	Test dependent power
CPICH	CPICH_Ec / I _{or} = -3,3 dB
P-CCPCH	P-CCPCH_Ec / I _{or} = -5,3 dB
SCH	SCH_Ec / I _{or} = -5,3 dB
PICH	PICH_Ec / I _{or} = -8,3 dB
S-CCPCH	S-CCPCH_Ec / I _{or} = -10,3 dB

E.3 During connection

The following clauses describe the downlink Physical Channels that are transmitted during a connection i.e., when measurements are done. For these measurements the offset between DPCH and SCH shall be zero chips at base station meaning that SCH is overlapping with the first symbols in DPCH in the beginning of DPCH slot structure.

E.3.1 Measurement of Tx Characteristics

Table E.3.1 is applicable for measurements on the Transmitter Characteristics (clause 5) with the exception of clauses 5.3, 5.4.1, 5.4.4 and 5.5.2.

NOTE: Applicability to clause 5.7 (Power setting in uplink compressed mode) is FFS.

Table E.3.1: Downlink Physical Channels transmitted during a connection

Physical Channel	Power
\hat{I}_{or}	-93 dBm / 3,84MHz
CPICH	CPICH_Ec / DPCH_Ec = 7 dB
P-CCPCH	P-CCPCH_Ec / DPCH_Ec = 5 dB
SCH	SCH_Ec / DPCH_Ec = 5 dB
PICH	PICH_Ec / DPCH_Ec = 2 dB
DPCH	-103,3 dBm / 3,84MHz

E.3.2 Measurement of Rx Characteristics

Table E.3.2.1 is applicable for measurements on the Receiver Characteristics (clause 6) with the exception of clauses 6.3 and 6.8.

Table E.3.2.1: Downlink Physical Channels transmitted during a connection

Physical Channel	Power
CPICH	CPICH_Ec / DPCH_Ec = 7 dB
P-CCPCH	P-CCPCH_Ec / DPCH_Ec = 5 dB
SCH	SCH_Ec / DPCH_Ec = 5 dB
PICH	PICH_Ec / DPCH_Ec = 2 dB
DPCH	Test dependent power

Table E.3.2.2 describes the downlink Physical Channels that are required for the test of Spurious Emissions (clause 6.8). The UE is in the CELL_FACH state during the measurement.

Table E.3.2.2: Downlink Physical Channels transmitted during the measurement for Rx Spurious Emissions

Physical Channel	Power
CPICH	-96 dBm / 3,84MHz
P-CCPCH	P-CCPCH_Ec / CPICH_Ec = -2 dB
SCH	SCH_Ec / CPICH_Ec = -2 dB
PICH	PICH_Ec / CPICH_Ec = -5 dB

E.3.3 Measurement of Performance requirements

Table E.3.3 is applicable for measurements on the Performance requirements (clause 7), including clauses 6.3 and 5.4.4, excluding clauses 7.6.1 and 7.6.2.

Table E.3.3: Downlink Physical Channels transmitted during a connection¹

Physical Channel	Power	Note
P-CPICH	P-CPICH_Ec/Ior = -10 dB	Use of P-CPICH or S-CPICH as phase reference is specified for each requirement and is also set by higher layer signalling.
S-CPICH	S-CPICH_Ec/Ior = -10 dB	When S-CPICH is the phase reference in a test condition, the phase of S-CPICH shall be 180 degrees offset from the phase of P-CPICH. When S-CPICH is not the phase reference, it is not transmitted.
P-CCPCH	P-CCPCH_Ec/Ior = -12 dB	
SCH	SCH_Ec/Ior = -12 dB	This power shall be divided equally between Primary and Secondary Synchronous channels
PICH	PICH_Ec/Ior = -15 dB	
DPCH	Test dependent power	When S-CPICH is the phase reference in a test condition, the phase of DPCH shall be 180 degrees offset from the phase of P-CPICH.
OCNS	Necessary power so that total transmit power spectral density of Node B (Ior) adds to one	OCNS interference consists of 16 dedicated data channels as specified in table E.3.6.
NOTE: For dynamic power correction required to compensate for the presence of transient channels, e.g. control channels, a subset of the DPCH channels may be used.		

¹ Power levels are based on the assumption that multipath propagation conditions and noise source representing interference from other cells Ioc are turned on after the call set-up phase.

E.3.4 Connection with open-loop transmit diversity mode

Table E.3.4 is applicable for measurements for clause 7.6.1.

Table E.3.4: Downlink Physical Channels transmitted during a connection²

Physical Channel	Power	Note
P-CPICH (antenna 1)	$P\text{-CPICH_Ec1/I_{or}} = -13 \text{ dB}$	1. Total $P\text{-CPICH_Ec/I_{or}} = -10 \text{ dB}$
P-CPICH (antenna 2)	$P\text{-CPICH_Ec2/I_{or}} = -13 \text{ dB}$	
P-CPICH (antenna 1)	$P\text{-CPICH_Ec1/I_{or}} = -13 \text{ dB}$	1. Total $P\text{-CPICH_Ec/I_{or}} = -10 \text{ dB}$
P-CPICH (antenna 2)	$P\text{-CPICH_Ec2/I_{or}} = -13 \text{ dB}$	
P-CCPCH (antenna 1)	$P\text{-CCPCH_Ec1/I_{or}} = -15 \text{ dB}$	1. STTD applied 2. Total $P\text{-CCPCH_Ec/I_{or}} = -12 \text{ dB}$
P-CCPCH (antenna 2)	$P\text{-CCPCH_Ec2/I_{or}} = -15 \text{ dB}$	
SCH (antenna 1 / 2)	$SCH_Ec/I_{or} = -12 \text{ dB}$	1. TSTD applied. 2. This power shall be divided equally between Primary and Secondary Synchronous channels
PICH (antenna 1)	$PICH_Ec1/I_{or} = -18 \text{ dB}$	1. STTD applied 2. Total $PICH_Ec/I_{or} = -15 \text{ dB}$
PICH (antenna 2)	$PICH_Ec2/I_{or} = -18 \text{ dB}$	
DPCH	Test dependent power	1. STTD applied 2. Total power from both antennas
OCNS	Necessary power so that total transmit power spectral density of Node B (I_{or}) adds to one	1. This power shall be divided equally between antennas 2. OCNS interference consists of 16 dedicated data channels as specified in Table E.3.6.
NOTE: For dynamic power correction required to compensate for the presence of transient channels, e.g. control channels, a subset of the DPCH channels may be used.		

² Power levels are based on the assumption that multipath propagation conditions and noise source representing interference from other cells I_{oc} are turned on after the call set-up phase.

E.3.5 Connection with closed loop transmit diversity mode

table E.3.5 is applicable for measurements for clause 7.6.2.

Table E.3.5: Downlink Physical Channels transmitted during a connection³

Physical Channel	Power	Note
P-CPICH (antenna 1)	$P\text{-CPICH_Ec1/lor} = -13 \text{ dB}$	1. Total P-CPICH_Ec/lor = -10 dB
P-CPICH (antenna 2)	$P\text{-CPICH_Ec2/lor} = -13 \text{ dB}$	
P-CCPCH (antenna 1)	$P\text{-CCPCH_Ec1/lor} = -15 \text{ dB}$	1. STTD applied
P-CCPCH (antenna 2)	$P\text{-CCPCH_Ec2/lor} = -15 \text{ dB}$	1. STTD applied, total P-CCPCH_Ec/lor = -12 dB
SCH (antenna 1 / 2)	$SCH_Ec/lor = -12 \text{ dB}$	1. TSTD applied
PICH (antenna 1)	$PICH_Ec1/lor = -18 \text{ dB}$	1. STTD applied 2. STTD applied, total PICH_Ec/lor = -15 dB
PICH (antenna 2)	$PICH_Ec2/lor = -18 \text{ dB}$	
DPCH	Test dependent power	1. Total power from both antennas
OCNS	Necessary power so that total transmit power spectral density of Node B (lor) adds to one	1. This power shall be divided equally between antennas 2. OCNS interference consists of 16 dedicated data channels as specified in Table E.3.6.
NOTE: For dynamic power correction required to compensate for the presence of transient channels, e.g. control channels, a subset of the DPCH channels may be used.		

Table E.3.6: DPCH Channelization Code and relative level settings for OCNS signal.

Channelization Code at SF=128	Relative Level setting (dB)	DPCH Data
2	-1	The DPCH data for each channelization code shall be uncorrelated with each other and with any wanted signal over the period of any measurement.
11	-3	
17	-3	
23	-5	
31	-2	
38	-4	
47	-8	
55	-7	
62	-4	
69	-6	
78	-5	
85	-9	
94	-10	
125	-8	
113	-6	
119	0	

NOTE: The DPCH Channelization Codes and relative level settings are chosen to simulate a signal with realistic Peak to Average Ratio.

³ Power levels are based on the assumption that multipath propagation conditions and noise source representing interference from other cells Ioc are turned on after the call set-up phase.

E.4 W-CDMA Modulated Interferer

Table E.4.1 describes the downlink Physical Control Channels that are transmitted as part of the W-CDMA modulated interferer.

Table E.4.1: Spreading Code, Timing offsets and relative level settings for W-CDMA Modulated Interferer signal control channels.

Channel Type	Spreading Factor	Channelization Code	Timing offset ($\times 256T_{\text{chip}}$)	Relative level setting (dB)	NOTE
P-CCPCH	256	1	0	-1	
SCH	256	-	0	-1	The SCH power shall be divided equally between Primary and Secondary Synchronous channels
P-CPICH	256	0	0	-1	
PICH	256	16	16	-6	

See table E.3.6 for the definition of the 16 DPCH portion of the W-CDMA modulated interferer.

Annex F (normative): General test conditions and declarations

The requirements of this clause apply to all applicable tests in the present document.

Many of the tests in the present document measure a parameter relative to a value that is not fully specified in the UE specifications. For these tests, the Minimum Requirement is determined relative to a nominal value specified by the manufacturer.

When specified in a test, the manufacturer shall declare the nominal value of a parameter, or whether an option is supported.

In all the relevant clauses in this clause all Bit Error Ratio (BER), Block Error Ratio (BLER), False transmit format Detection Ratio (FDR) measurements shall be carried out according to the general rules for statistical testing in clause F.6.

F.1 Acceptable uncertainty of Test System

The maximum acceptable uncertainty of the Test System is specified below for each test, where appropriate. The Test System shall enable the stimulus signals in the test case to be adjusted to within the specified range, and the equipment under test to be measured with an uncertainty not exceeding the specified values. All ranges and uncertainties are absolute values, and are valid for a confidence level of 95 %, unless otherwise stated.

A confidence level of 95 % is the measurement uncertainty tolerance interval for a specific measurement that contains 95 % of the performance of a population of test equipment.

For RF tests it should be noted that the uncertainties in clause F.1 apply to the Test System operating into a nominal 50 ohm load and do not include system effects due to mismatch between the DUT and the Test System.

F.1.1 Measurement of test environments

The measurement accuracy of the UE test environments defined in annex G, Test environments shall be.

- Pressure ± 5 kPa.
- Temperature ± 2 degrees.
- Relative Humidity ± 5 %.
- DC Voltage $\pm 1,0$ %.
- AC Voltage $\pm 1,5$ %.
- Vibration 10 %.
- Vibration frequency 0,1 Hz.

The above values shall apply unless the test environment is otherwise controlled and the specification for the control of the test environment specifies the uncertainty for the parameter.

F.1.2 Measurement of transmitter

Table F.1.2: Maximum Test System Uncertainty for transmitter tests

Clause	Maximum Test System Uncertainty	Derivation of Test System Uncertainty
5.2 Maximum Output Power	±0,7 dB	
5.3 Frequency Error	±10 Hz	
5.4.1 Open loop power control in uplink	±1,0 dB	The uncertainty of this test is a combination of the downlink level setting error and the uplink power measurement that are uncorrelated. Formula = SQRT(source_level_error ² + power_meas_error ²)
5.4.2 Inner loop power control in the uplink - One step	±0,1 dB relative over a 1,5 dB range (1 dB and 0 dB step) ±0,15 dB relative over a 3,0 dB range (2 dB step) ±0,2 dB relative over a 4.5 dB range (3 dB step)	This accuracy is based on the linearity of the absolute power measurement of the test equipment.
5.4.2 Inner loop power control in the uplink – seven and ten steps	±[0,3] dB relative over a 26 dB range	
5.4.3 Minimum Output Power	±1,0 dB	Measured on a static signal
5.4.4 Out-of-synchronisation handling of output power: $\frac{DPCCH_E_c}{I_{or}}$	±0,4 dB	0.1 dB uncertainty in DPCCH ratio 0.3 dB uncertainty in \hat{I}_{or}/I_{oc} based on power meter measurement after the combiner Overall error is the sum of the \hat{I}_{or}/I_{oc} ratio error and the DPCCH_Ec/I _{or} ratio. The absolute error of the AWGN loc is not important but is specified as 1.0 dB
5.5.1 Transmit OFF Power: (static case)	±1,0 dB	Measured on a static signal
5.5.2 Transmit ON/OFF time mask (dynamic case)	On power +0,7 dB – 1,0 dB Off power (dynamic case) TBD	Assume asymmetric meas error -1.0 dB / 0.7 dB comprising RSS of: -0.7 dB downlink error plus -0.7 dB meas error, and +0.7 dB for upper limit (assume UE won't go above 24 nominal). For the off power, the accuracy of a two-pass measurement needs to be analysed.
5.6 Change of TFC: power control step size (7 dB step)	±0,3 dB relative over a 9 dB range	
5.7 Power setting in uplink compressed mode:-UE output power	Will be a subset of 5.4.2.	
5.8 Occupied Bandwidth	±100 kHz	Accuracy = ±3*RBW. Assume 30 kHz bandwidth.
5.9 Spectrum emission mask	±1,5 dB	
5.10 ACLR	5 MHz offset: ± 0,8 dB 10 MHz offset: ± 0,8 dB	

Clause	Maximum Test System Uncertainty	Derivation of Test System Uncertainty
5.11 Spurious emissions	$\pm 2,0$ dB for UE and coexistence bands for results > -60 dBm $\pm 3,0$ dB for results < -60 dBm Outside above: $f \leq 2.2$ GHz: ± 1.5 dB 2.2 GHz $< f \leq 4$ GHz: ± 2.0 dB $f > 4$ GHz: ± 4.0 dB	
5.12 Transmit Intermodulation	± 2.2 dB	CW Interferer error is 0.7 dB for the UE power RSS with 0.7 dB for CW setting = 1.0 dB Measurement error of intermod product is 0.7 dB for UE power RSS with 0.7 dB for relative = 1.0 dB Interferer has an effect of 2 times on the intermod product so overall test uncertainty is 2×1.0 RSS with 1.0 = 2.2 dB. Apply half any excess test system uncertainty to increase the interferer level
5.13.1 Transmit modulation: EVM	± 2.5 % (for single code)	
5.13.2 Transmit modulation: peak code domain error	± 1.0 dB	

F.1.3 Measurement of receiver

Table F.1.3: Maximum Test System Uncertainty for receiver tests

Clause	Maximum Test System Uncertainty	Derivation of Test System Uncertainty
6.2 Reference sensitivity level	± 0.7 dB	
6.3 maximum input level:	± 0.7 dB	<p>The critical parameter is the overall signal level and not the -19 dB DPCH_Ec/Ior ratio.</p> <p>0.7 dB absolute error due to signal measurement</p> <p>DPCH_Ec/Ior ratio error is <0.1 dB but is not important so is ignored</p>
6.4 Adjacent channel selectivity	± 1.1 dB	<p>Overall system uncertainty comprises three quantities:</p> <ol style="list-style-type: none"> 1. Wanted signal level error 2. Interferer signal level error 3. Additional impact of interferer ACLR <p>Items 1 and 2 are assumed to be uncorrelated so can be root sum squared to provide the ratio error of the two signals. Assume for simplicity this ratio error is linearly added to the interferer ACLR.</p> <p>Test System uncertainty = $\text{SQRT}(\text{wanted_level_error}^2 + \text{interferer_level_error}^2) + \text{ACLR effect}$.</p> <p>The ACLR effect is calculated by:(Formula to follow)</p> <p>(E.g. ACLR at 5 MHz of 51 dB gives additional error of .0765 dB. ACLR of 48 gives error of -0.15 dB.)</p>
6.5 Blocking characteristics	<p>System error with $f < 15$ MHz offset: ± 1.4 dB</p> <p>$f \geq 15$ MHz offset and $f_b \leq 2.2$ GHz: ± [1.0] dB</p> <p>2.2 GHz < $f \leq 4$ GHz: ±[1.7] dB</p> <p>$f > 4$ GHz: ±[3.1] dB</p>	Using ± 0.7 dB for signal and interferer as currently defined and 68 dB ACLR @ 10 MHz.
6.6 Spurious Response	<p>$f \leq 2.2$ GHz: ± 1.0 dB</p> <p>2.2 GHz < $f \leq 4$ GHz: ±1.7 dB</p> <p>$f > 4$ GHz: ±3.1 dB</p>	

Clause	Maximum Test System Uncertainty	Derivation of Test System Uncertainty
6.7 Intermodulation Characteristics	±1.3 dB	<p>Similar issues to 7.4 ACS test.</p> <p>ETR028 says impact f the closer signal is twice that of the far signal. If both signals drop 1 dB, intermod product drops 2 dB.</p> <p>Formula =</p> $\sqrt{(2 \cdot CW_level_error)^2 + (mod_level_error)^2}$ <p>(Using CW interferer ±0.5 dB, modulated interferer ±0.5 dB, wanted signal ±0.7 dB) 1.3 dB!</p> <p>Broadband noise/ACLR not considered but may have impact.</p>
6.8 Spurious emissions	± 3.0 dB for UE receive band (-78 dBm) Outside above: f ≤ 2.2GHz: ± 2.0 dB (-57 dBm) 2.2 GHz < f ≤ 4 GHz: ± 2.0 dB (-47 dBm) f > 4 GHz: ±4.0 dB (-47 dBm)	

F.1.4 Performance requirement

Table F.1.4: Maximum Test System Uncertainty for Performance Requirements

Clause	Maximum Test System Uncertainty	Derivation of Test System Uncertainty
7.2 Demodulation in Static Propagation Condition	\hat{I}_{or}/I_{oc} ± 0.3 dB I_{oc} ± 1.0 dB $\frac{DPCH_E_c}{I_{or}}$ ± 0.1 dB	<p>0.1 dB uncertainty in DPCH_Ec ratio</p> <p>0.3 dB uncertainty in \hat{I}_{or}/I_{oc} based on power meter measurement after the combiner</p> <p>Overall error is the sum of the \hat{I}_{or}/I_{oc} ratio error and the DPCH_Ec/Ior ratio but is not RSS for simplicity. The absolute error of the AWGN loc is not important for any tests in clause 7 but is specified as 1.0 dB.</p>
7.3 Demodulation of DCH in multipath Fading Propagation conditions	\hat{I}_{or}/I_{oc} ± 0.56 dB I_{oc} ± 1.0 dB $\frac{DPCH_E_c}{I_{or}}$ ± 0.1 dB	<p>Worst case gain uncertainty due to the fader from the calibrated static profile is ± 0.5 dB</p> <p>In addition the same ± 0.3 dB \hat{I}_{or}/I_{oc} ratio error as 7.2.</p> <p>These are uncorrelated so can be RSS.</p> <p>Overall error in \hat{I}_{or}/I_{oc} is $(0.5^2 + 0.3^2)^{0.5} = 0.6$ dB</p>
7.4 Demodulation of DCH in Moving Propagation conditions	\hat{I}_{or}/I_{oc} ± 0.6 dB I_{oc} ± 1.0 dB $\frac{DPCH_E_c}{I_{or}}$ ± 0.1 dB	Same as 7.3
7.5 Demodulation of DCH in Birth-Death Propagation conditions	\hat{I}_{or}/I_{oc} ± 0.6 dB I_{oc} ± 1.0 dB $\frac{DPCH_E_c}{I_{or}}$ ± 0.1 dB	Same as 7.3
7.6.1 Demodulation of DCH in open loop Transmit diversity mode	\hat{I}_{or}/I_{oc} ± 0.8 dB I_{oc} ± 1.0 dB $\frac{DPCH_E_c}{I_{or}}$ ± 0.1 dB	<p>Worst case gain uncertainty due to the fader from the calibrated static profile is ± 0.5 dB per output</p> <p>In addition the same ± 0.3 dB \hat{I}_{or}/I_{oc} ratio error as 7.2.</p> <p>These are uncorrelated so can be RSS.</p> <p>Overall error in \hat{I}_{or}/I_{oc} is $(0.5^2 + 0.5^2 + 0.3^2)^{0.5} = 0.768$ dB. Round up to 0.8 dB</p>

Clause	Maximum Test System Uncertainty	Derivation of Test System Uncertainty
7.6.2 Demodulation of DCH in closed loop Transmit diversity mode	\hat{I}_{or}/I_{oc} ±0.8 dB I_{oc} ±1.0 dB $\frac{DPCH_E_c}{I_{or}}$ ±0.1 dB	Same as 7.6.1
7.6.3, Demodulation of DCH in site selection diversity Transmission power control mode	\hat{I}_{or}/I_{oc} ±0.8 dB I_{oc} ±1.0 dB $\frac{DPCH_E_c}{I_{or}}$ ±0.1 dB	Same as 7.6.1
7.7.1 Demodulation in inter-cell soft Handover	\hat{I}_{or}/I_{oc} ±0.8 dB I_{oc} ±1.0 dB $\frac{DPCH_E_c}{I_{or}}$ ±0.1 dB	Same as 7.6.1
7.7.2 Combining of TPC commands Test 1	I_{or1}, I_{or2} ±1.0 dB $\frac{DPCH_E_c}{I_{or}}$ ±0.1 dB	Test is looking for changes in power – need to allow for relaxation in criteria for power step of probably 0.1 dB to 0.4 dB
7.7.2 Combining of TPC commands Test 2	\hat{I}_{or}/I_{oc} ±0.8 dB I_{oc} ±1.0 dB $\frac{DPCH_E_c}{I_{or}}$ ±0.1 dB	Same as 7.6.1
7.8.1 Power control in downlink constant BLER target	\hat{I}_{or}/I_{oc} ±0.6 dB I_{oc} ±1.0 dB $\frac{DPCH_E_c}{I_{or}}$ ±0.1 dB	Same as 7.3
7.8.2, Power control in downlink initial convergence	\hat{I}_{or}/I_{oc} ±0.6 dB I_{oc} ±1.0 dB $\frac{DPCH_E_c}{I_{or}}$ ±0.1 dB	Same as 7.3
7.8.3, Power control in downlink: wind up effects	\hat{I}_{or}/I_{oc} ±0.6 dB I_{oc} ±1.0 dB $\frac{DPCH_E_c}{I_{or}}$ ±0.1 dB	Same as 7.3
7.9 Downlink compressed mode	\hat{I}_{or}/I_{oc} ±0.6 dB I_{oc} ±1.0 dB $\frac{DPCH_E_c}{I_{or}}$ ±0.1 dB	Same as 7.3
7.10 Blind transport format detection Tests 1, 2, 3	\hat{I}_{or}/I_{oc} ±0.3 dB I_{oc} ±1.0 dB $\frac{DPCH_E_c}{I_{or}}$ ±0.1 dB	Same as 7.2

Clause	Maximum Test System Uncertainty	Derivation of Test System Uncertainty
7.10 Blind transport format detection Tests 4, 5, 6	\hat{I}_{or}/I_{oc} ± 0.6 dB I_{oc} ± 1.0 dB $\frac{DPCH - E_c}{I_{or}}$ ± 0.1 dB	Same as 7.3

F.1.5 Requirements for support of RRM

Table F.1.5: Maximum Test System Uncertainty for Radio Resource Management Tests

Clause	Maximum Test System Uncertainty	Derivation of Test System Uncertainty
8.2 Idle Mode Tasks		
8.2.2 Cell Re-Selection		
8.2.2.1 Scenario 1: Single carrier case	\hat{I}_{or}/I_{oc} ± 0.3 dB I_{oc} ± 1.0 dB $\frac{CPICH_E_c}{I_{or}}$ ± 0.1 dB	<p>0.1 dB uncertainty in CPICH_Ec ratio</p> <p>0.3 dB uncertainty in \hat{I}_{or}/I_{oc} based on power meter measurement after the combiner</p> <p>The absolute error of the AWGN is specified as 1.0 dB.</p>
8.2.2.2 Scenario 2: Multi carrier case	\hat{I}_{or}/I_{oc} ± 0.3 dB I_{oc} ± 1.0 dB I_{oc1}/I_{oc2} ± 0.3 dB $\frac{CPICH_E_c}{I_{or}}$ ± 0.1 dB	<p>0.1 dB uncertainty in CPICH_Ec ratio</p> <p>0.3 dB uncertainty in \hat{I}_{or}/I_{oc} based on power meter measurement after the combiner</p> <p>0.3 dB uncertainty in loc1/loc2 based on power meter measurement after the combiner</p> <p>Overall error for the CPICH_Ec/Io is the sum of the \hat{I}_{or}/I_{oc} ratio error and the CPICH_Ec/Ior ratio.</p> <p>The absolute error of the AWGN is specified as 1.0 dB.</p>
8.2.3 UTRAN to GSM Cell Re-Selection		

Clause	Maximum Test System Uncertainty	Derivation of Test System Uncertainty
8.2.3.1 Scenario 1: Both UTRA and GSM level changed	\hat{I}_{or}/I_{oc} ± 0.3 dB $I_{oc}/RXLEV$ ± 0.3 dB I_{oc} ± 1.0 dB RXLEV ± 1.0 dB $\frac{CPICH - E_c}{I_{or}}$ ± 0.1 dB	0.1 dB uncertainty in CPICH_Ec ratio 0.3 dB uncertainty in \hat{I}_{or}/I_{oc} based on power meter measurement after the combiner 0.3 dB uncertainty in loc/RXLEV based on power meter measurement after the combiner The absolute error of the AWGN is specified as 1.0 dB. The absolute error of the RXLEV is specified as 1.0 dB.
8.2.3.2 Scenario 2: Only UTRA level changed	\hat{I}_{or}/I_{oc} ± 0.3 dB $I_{oc}/RXLEV$ ± 0.3 dB I_{oc} ± 1.0 dB RXLEV ± 1.0 dB $\frac{CPICH - E_c}{I_{or}}$ ± 0.1 dB	Same as 8.2.3.1
8.2.4 FDD/TDD cell re-selection	\hat{I}_{or}/I_{oc} ± 0.3 dB I_{oc} ± 1.0 dB I_{oc1}/I_{oc2} ± 0.3 dB $\frac{CPICH - E_c}{I_{or}}$ ± 0.1 dB	Same as 8.2.2.2
8.3 UTRAN Connected Mode Mobility		
8.3.1 FDD/FDD Soft Handover		No test case
8.3.2 FDD/FDD Hard Handover	TBD	
8.3.3 FDD/TDD Handover	TBD	
8.3.4 Inter-system Handover form UTRAN FDD to GSM	TBD	
8.3.5 Cell Re-selection in CELL_FACH		
8.3.5.1 One frequency present in the neighbour list	Same as 8.2.2.1	Same as 8.2.2.1
8.3.5.2 Two frequencies present in the neighbour list	Same as 8.2.2.2	Same as 8.2.2.2
8.3.6 Cell Re-selection in CELL_PCH		
8.3.6.1 One frequency present in the neighbour list	Same as 8.2.2.1	Same as 8.2.2.1
8.3.6.2 Two frequencies present in the neighbour list	Same as 8.2.2.2	Same as 8.2.2.2
8.3.7 Cell Re-selection in URA_PCH		
8.3.7.1 One frequency present in the neighbour list	Same as 8.2.2.1	Same as 8.2.2.1
8.3.7.2 Two frequencies present in the neighbour list	Same as 8.2.2.2	Same as 8.2.2.2
8.4 RRC Connection Control	TBD	
8.4.1 RRC Re-establishment delay		

Clause	Maximum Test System Uncertainty	Derivation of Test System Uncertainty
8.4.2 Random Access	\hat{I}_{or}/I_{oc} ± 0.3 dB I_{oc} ± 1.0 dB $\frac{AICH - E_c}{I_{or}}$ ± 0.1 dB	<p>0.1 dB uncertainty in AICH_Ec ratio</p> <p>0.3 dB uncertainty in \hat{I}_{or}/I_{oc} based on power meter measurement after the combiner</p> <p>Overall error is the sum of the \hat{I}_{or}/I_{oc} ratio error and the AICH_Ec/Ior ratio.</p> <p>The absolute error of the AWGN is specified as 1.0 dB</p>
8.5 Timing and Signalling Characteristics		
8.5.1 UE Transmit Timing	I_{or} ± 1.0 dB I_{or1}/I_{or2} ± 0.3 dB $\frac{DPCH - E_c}{I_{or}}$ ± 0.1 dB	<p>0.1 dB uncertainty in DPCH_Ec ratio</p> <p>0.3 dB uncertainty in Ior1/Ior2 based on power meter measurement after the combiner</p> <p>The absolute error of the Ior is specified as 1.0 dB.</p>
8.6 UE Measurements Procedures		
8.6.1 FDD intra frequency measurements		
8.6.1.1 Event triggered reporting in AWGN propagation conditions	TBD	
8.6.1.2 Event triggered reporting of multiple neighbours in AWGN propagation condition	TBD	
8.6.1.3 Event triggered reporting of two detectable neighbours in AWGN propagation condition	TBD	
8.6.1.4 Correct reporting of neighbours in fading propagation condition	TBD	
8.6.2 FDD inter frequency measurements		
8.6.2.1 Correct reporting of neighbours in AWGN propagation condition	TBD	
8.6.2.2 Correct reporting of neighbours in Fading propagation condition	TBD	
8.6.3 TDD measurements	TBD	
8.6.3.1 Correct reporting of TDD neighbours in AWGN propagation condition	TBD	
8.7 Measurements Performance Requirements		
8.7.1 CPICH RSCP		
8.7.1.1 Intra frequency measurements accuracy	\hat{I}_{or}/I_{oc} ± 0.3 dB I_{oc} ± 1.0 dB $\frac{CPICH - E_c}{I_{or}}$ ± 0.1 dB	Same as 8.2.2.1

Clause	Maximum Test System Uncertainty	Derivation of Test System Uncertainty
8.7.1.2 Inter frequency measurement accuracy	\hat{I}_{or}/I_{oc} ± 0.3 dB I_{oc} ± 1.0 dB I_{oc1}/I_{oc2} ± 0.3 dB $\frac{CPICH - E_c}{I_{or}}$ ± 0.1 dB	Same as 8.2.2.2
8.7.2 CPICH Ec/Io		
8.7.1.1 Intra frequency measurements accuracy	\hat{I}_{or}/I_{oc} ± 0.3 dB I_{oc} ± 1.0 dB $\frac{CPICH - E_c}{I_{or}}$ ± 0.1 dB	Same as 8.2.2.1
8.7.1.2 Inter frequency measurement accuracy	\hat{I}_{or}/I_{oc} ± 0.3 dB I_{oc} ± 1.0 dB I_{oc1}/I_{oc2} ± 0.3 dB $\frac{CPICH - E_c}{I_{or}}$ ± 0.1 dB	Same as 8.2.2.2
8.7.3A UTRA Carrier RSSI	\hat{I}_{or}/I_{oc} ± 0.3 dB I_{oc} ± 1.0 dB I_{oc1}/I_{oc2} ± 0.3 dB	<p>0.3 dB uncertainty in \hat{I}_{or}/I_{oc} based on power meter measurement after the combiner</p> <p>0.3 dB uncertainty in I_{oc1}/I_{oc2} based on power meter measurement after the combiner</p> <p>The absolute error of the AWGN is specified as 1.0 dB</p>
8.7.3B Transport channel BLER	TBD	
8.7.3C UE Transmitted power	Mean power measurement $\pm 0,7$ dB	Downlink parameters are unimportant.
8.7.4 SFN-CFN observed time difference	TBD	
8.7.5 SFN-SFN observed time difference	TBD	
8.7.6 UE Rx-Tx time difference	\hat{I}_{or}/I_{oc} ± 0.3 dB I_{oc} ± 1.0 dB Rx-Tx Timing Accuracy $[\pm 0.5$ chip]	<p>0.3 dB uncertainty in \hat{I}_{or}/I_{oc} based on power meter measurement after the combiner</p> <p>The absolute error of the AWGN is specified as 1.0 dB.</p>
8.7.7 Observed time difference to GSM cell	TBD	
8.7.8 P-CCPCH RSCP	TBD	

F.2 Test Tolerances (This clause is informative)

The Test Tolerances defined in this clause have been used to relax the Minimum Requirements in the present document to derive the Test Requirements.

The Test Tolerances are derived from Test System uncertainties, regulatory requirements and criticality to system performance. As a result, the Test Tolerances may sometimes be set to zero.

The test tolerances should not be modified for any reason e.g. to take account of commonly known test system errors (such as mismatch, cable loss, etc.).

F.2.1 Transmitter

Table F.2.1: Test Tolerances for transmitter tests.

Clause	Test Tolerance
5.2 Maximum Output Power	0.7 dB
5.3 Frequency error	10 Hz
5.4.1 Open loop power control in uplink	1.0 dB
5.4.2 Inner loop power control in the uplink - One step	0.1 dB (1 dB and 0 dB step) 0.15 dB (2 dB step) 0.2 dB (3 dB step)
5.4.2 Inner loop power control in the uplink - seven and ten steps	[0.3] dB
5.4.3 Minimum Output Power	1.0 dB
5.4.4 Out-of-synchronisation handling of output power: $\frac{DPCCH - E_c}{I_{or}}$	0.4 dB
5.4.4 Out-of-synchronisation handling of output power: transmit ON/OFF time	0 ms
5.5.1 Transmit OFF power	1.0 dB
5.5.2 Transmit ON/OFF time mask (dynamic case)	On power +0.7 dB / -1.0 dB Off power TT [] dB
5.6 Change of TFC: power control step size	0.3 dB
5.7 Power setting in uplink compressed mode:-UE output power	See subset of 5.4.2
5.8 Occupied Bandwidth	0 kHz
5.9 Spectrum emission mask	1.5 dB (0 dB for additional requirements for Band II)
5.10 ACLR	0.8 dB for ratio 0.0 dB for absolute power
5.11 Spurious emissions	0 dB
5.12 Transmit Intermodulation	0 dB
5.13.1 Transmit modulation: EVM	0%
5.13.2 Transmit modulation: peak code domain error	1.0 dB

F.2.2 Receiver

Table F.2.2: Test Tolerances for receiver tests.

Clause	Test Tolerance
6.2 Reference sensitivity level	0.7 dB
6.3 Maximum input level:	0.7 dB
6.4 Adjacent channel selectivity	0 dB
6.5 Blocking characteristics	0 dB
6.6 Spurious Response	0 dB
6.7 Intermodulation Characteristics	0 dB
6.8 Spurious emissions	0 dB

F.2.3 Performance requirements

Table F.2.3: Test Tolerances for Performance Requirements.

Clause	Test Tolerance
7.2 Demodulation in Static Propagation Condition	0.3 dB for \hat{I}_{or}/I_{oc} 0.1 dB for DPCH_Ec/lor
7.3 Demodulation of DCH in multipath Fading Propagation conditions	0.6 dB for \hat{I}_{or}/I_{oc} 0.1 dB for DPCH_Ec/lor
7.4 Demodulation of DCH in Moving Propagation conditions	0.6 dB for \hat{I}_{or}/I_{oc} 0.1 dB for DPCH_Ec/lor
7.5 Demodulation of DCH in Birth-Death Propagation conditions	0.6 dB for \hat{I}_{or}/I_{oc} 0.1 dB for DPCH_Ec/lor
7.6.1 Demodulation of DCH in open loop Transmit diversity mode	0.8 dB for \hat{I}_{or}/I_{oc} 0.1 dB for DPCH_Ec/lor
7.6.2 Demodulation of DCH in closed loop Transmit diversity mode	0.8 dB for \hat{I}_{or}/I_{oc} 0.1 dB for DPCH_Ec/lor
7.6.3, Demodulation of DCH in site selection diversity Transmission power control mode	0.8 dB for \hat{I}_{or}/I_{oc} 0.1 dB for DPCH_Ec/lor
7.7.1 Demodulation in inter-cell soft Handover conditions	0.8 dB for \hat{I}_{or}/I_{oc} 0.1 dB for DPCH_Ec/lor
7.7.2 Combining of TPC commands Test 1	0 dB for lor1, lor2 0.1 dB for DPCH_Ec/lor
7.7.2 Combining of TPC commands Test 2	0.8 dB for \hat{I}_{or}/I_{oc} 0.1 dB for DPCH_Ec/lor
7.8.1 Power control in downlink constant BLER target	0.6 dB for \hat{I}_{or}/I_{oc} 0.1 dB for DPCH_Ec/lor
7.8.2, Power control in downlink initial convergence	0.6 dB for \hat{I}_{or}/I_{oc} 0.1 dB for DPCH_Ec/lor
7.8.3, Power control in downlink: wind up effects	0.6 dB for \hat{I}_{or}/I_{oc} 0.1 dB for DPCH_Ec/lor
7.9 Downlink compressed mode	0.6 dB for \hat{I}_{or}/I_{oc} 0.1 dB for DPCH_Ec/lor
7.10 Blind transport format detection Tests 1, 2, 3	0.3 dB for \hat{I}_{or}/I_{oc} 0.1 dB for DPCH_Ec/lor
7.10 Blind transport format detection Tests 4, 5, 6	0.6 dB for \hat{I}_{or}/I_{oc} 0.1 dB for DPCH_Ec/lor

F.2.4 Requirements for support of RRM

Table F.2.4: Test Tolerances for Radio Resource Management Tests

Clause	Test Tolerance
8.2 Idle Mode Tasks	
8.2.2 Cell Re-Selection	
8.2.2.1 Scenario 1: Single carrier case	0.3 dB for \hat{I}_{or}/I_{oc} 0.1 dB for CPICH_Ec/lor
8.2.2.2 Scenario 2: Multi carrier case	0.3 dB for \hat{I}_{or}/I_{oc} 0.1 dB for CPICH_Ec/lor
8.2.3 UTRAN to GSM Cell Re-Selection	
8.2.3.1 Scenario 1: Both UTRA and GSM level changed	0.3 dB for \hat{I}_{or}/I_{oc} 0.1 dB for CPICH_Ec/lor 0.3 dB for loc/RXLEV
8.2.3.2 Scenario 2: Only UTRA level changed	0.3 dB for \hat{I}_{or}/I_{oc} 0.1 dB for CPICH_Ec/lor 0.3 dB for loc/RXLEV
8.2.4 FDD/TDD cell re-selection	0.3 dB for \hat{I}_{or}/I_{oc} 0.1 dB for CPICH_Ec/lor 0.3 dB for loc1/loc2
8.3 UTRAN Connected Mode Mobility	
8.3.1 FDD/FDD Soft Handover	
8.3.2 FDD/FDD Hard Handover	TBD
8.3.3 FDD/TDD Handover	TBD
8.3.4 Inter-system Handover form UTRAN FDD to GSM	TBD
8.3.5 Cell Re-selection in CELL_FACH	
8.3.5.1 One frequency present in the neighbour list	0.3 dB for \hat{I}_{or}/I_{oc} 0.1 dB for CPICH_Ec/lor
8.3.5.2 Two frequencies present in the neighbour list	0.3 dB for \hat{I}_{or}/I_{oc} 0.1 dB for CPICH_Ec/lor
8.3.6 Cell Re-selection in CELL_PCH	
8.3.6.1 One frequency present in the neighbour list	0.3 dB for \hat{I}_{or}/I_{oc} 0.1 dB for CPICH_Ec/lor
8.3.6.2 Two frequencies present in the neighbour list	0.3 dB for \hat{I}_{or}/I_{oc} 0.1 dB for CPICH_Ec/lor
8.3.7 Cell Re-selection in URA_PCH	
8.3.7.1 One frequency present in the neighbour list	0.3 dB for \hat{I}_{or}/I_{oc} 0.1 dB for CPICH_Ec/lor
8.3.7.2 Two frequencies present in the neighbour list	0.3 dB for \hat{I}_{or}/I_{oc} 0.1 dB for CPICH_Ec/lor
8.4 RRC Connection Control	
8.4.1 RRC Re-establishment delay	TBD
8.4.2 Random Access	0.3 dB for \hat{I}_{or}/I_{oc} 0.1 dB for AICH_Ec/lor
8.5 Timing and Signalling Characteristics	
8.5.1 UE Transmit Timing	TBD
8.6 UE Measurements Procedures	
8.6.1 FDD intra frequency measurements	
8.6.1.1 Event triggered reporting in AWGN propagation conditions	TBD
8.6.1.2 Event triggered reporting of multiple neighbours in AWGN propagation condition	TBD

Clause	Test Tolerance
8.6.1.3 Event triggered reporting of two detectable neighbours in AWGN propagation condition	TBD
8.6.1.4 Correct reporting of neighbours in fading propagation condition	TBD
8.6.2 FDD inter frequency measurements	
8.6.2.1 Correct reporting of neighbours in AWGN propagation condition	TBD
8.6.2.2 Correct reporting of neighbours in Fading propagation condition	TBD
8.6.3 TDD measurements	
8.6.3.1 Correct reporting of TDD neighbours in AWGN propagation condition	TBD
8.7 Measurements Performance Requirements	TBD
8.7.1 CPICH RSCP	
8.7.1.1 Intra frequency measurements accuracy	0.3 dB for \hat{I}_{or}/I_{oc} 0.1 dB for CPICH_Ec/lor 1.0 dB for loc
8.7.1.2 Inter frequency measurement accuracy	0.3 dB for \hat{I}_{or}/I_{oc} 0.1 dB for CPICH_Ec/lor 0.3 dB for loc1/loc2 1.0 dB for loc
8.7.2 CPICH Ec/Io	
8.7.1.1 Intra frequency measurements accuracy	0.3 dB for \hat{I}_{or}/I_{oc} 0.1 dB for CPICH_Ec/lor
8.7.1.2 Inter frequency measurement accuracy	0.3 dB for \hat{I}_{or}/I_{oc} 0.1 dB for CPICH_Ec/lor
8.7.3A UTRA Carrier RSSI	0.3 dB for \hat{I}_{or}/I_{oc} 1.0 dB for loc
8.7.3B Transport channel BLER	TBD
8.7.3C UE Transmitted power	0.7 dB for mean power measurement by test system
8.7.4 SFN-CFN observed time difference	
8.7.5 SFN-SFN observed time difference	
8.7.6 UE Rx-Tx time difference	0.3 dB for \hat{I}_{or}/I_{oc} 1.0 dB for loc [0.5 chip] for Rx-Tx Timing Accuracy
8.7.7 Observed time difference to GSM cell	TBD
8.7.8 P-CCPCH RSCP	TBD

F.3 Interpretation of measurement results

The measurement results returned by the Test System are compared – without any modification – against the Test Requirements as defined by the shared risk principle.

The Shared Risk principle is defined in ETR 273-1-2 clause 6.5.

The actual measurement uncertainty of the Test System for the measurement of each parameter shall be included in the test report.

The recorded value for the Test System uncertainty shall be, for each measurement, equal to or lower than the appropriate figure in clause F.1 of the present document.

If the Test System for a test is known to have a measurement uncertainty greater than that specified in clause F.1, it is still permitted to use this apparatus provided that an adjustment is made value as follows.

Any additional uncertainty in the Test System over and above that specified in clause F.1 shall be used to tighten the Test Requirement – making the test harder to pass. (For some tests e.g. receiver tests, this may require modification of stimulus signals). This procedure will ensure that a Test System not compliant with clause F.1 does not increase the chance of passing a device under test where that device would otherwise have failed the test if a Test System compliant with clause F.1 had been used.

F.4 Derivation of Test Requirements (This clause is informative)

The Test Requirements in the present document have been calculated by relaxing the Minimum Requirements of the core specification using the Test Tolerances defined in clause F.2. When the Test Tolerance is zero, the Test Requirement will be the same as the Minimum Requirement. When the Test Tolerance is non-zero, the Test Requirements will differ from the Minimum Requirements, and the formula used for this relaxation is given in table F.4.

Table F.4.1: Derivation of Test Requirements (Transmitter tests)

Test	Minimum Requirement in TS 25.101	Test Tolerance (TT)	Test Requirement in TS 34.121
5.2 Maximum Output Power	Power class 1 (33 dBm) Tolerance = +1/-3 dB Power class 2 (27 dBm) Tolerance = +1/-3 dB Power class 3 (24 dBm) Tolerance = +1/-3 dB Power class 4 (21 dBm) Tolerance = ± 2 dB	0.7 dB	Formula: Upper Tolerance limit + TT Lower Tolerance limit – TT For power classes 1-3: Upper Tolerance limit = +1.7 dB Lower Tolerance limit = -3.7 dB For power class 4: Upper Tolerance limit = +2.7 dB Lower Tolerance limit = -2.7 dB
5.3 Frequency Error	The UE modulated carrier frequency shall be accurate to within ± 0.1 ppm compared to the carrier frequency received from the Node B.	10 Hz	Formula: modulated carrier frequency error + TT modulated carrier frequency error = $\pm(0.1$ ppm + 10 Hz).
5.4.1 Open loop power control in the uplink	Open loop power control tolerance ± 9 dB (Normal) Open loop power control tolerance ± 12 dB (Normal)	1.0 dB	Formula: Upper Tolerance limit + TT Lower Tolerance limit – TT For Normal conditions: Upper Tolerance limit = +10 dB Lower Tolerance limit = -10 dB For Extreme conditions: Upper Tolerance limit = +13 dB Lower Tolerance limit = -13 dB
5.4.2 Inner loop power control in uplink	See table 5.4.2.1 and 5.4.2.2	0.25 dB 0.15 dB 0.2 dB [0.3 dB]	Formula: Upper Tolerance limit + TT Lower Tolerance limit – TT
5.4.3 Minimum Output Power	UE minimum transmit power shall be less than –50 dBm	1.0 dB	Formula: UE minimum transmit power + TT UE minimum transmit power = –49 dBm

Test	Minimum Requirement in TS 25.101	Test Tolerance (TT)	Test Requirement in TS 34.121
5.4.4 Out-of-synchronisation handling of output power:	$\frac{DPCCH_E_c}{I_{or}}$ levels AB: -22 dB BD: -28 dB DE: -24 dB EF: -18 dB transmit ON/OFF time 200ms $\frac{DPDCH_E_c}{I_{or}} = -16.6$ dB $I_{oc} - 60$ dBm $\hat{I}_{or}/I_{oc} = -1$ dB	0.4 dB for $\frac{DPCCH_E_c}{I_{or}}$ 0 ms for timing measurement	Formulas: Ratio between A and B + TT Ratio between B and D – TT Ratio between D and E – TT Ratio between E and F + TT transmit ON/OFF time + TT timing $\frac{DPDCH_E_c}{I_{or}} = -16.6$ dB $I_{oc} - 60$ dBm $\hat{I}_{or}/I_{oc} = -1$ dB $\frac{DPCCH_E_c}{I_{or}}$ levels: AB: -21.6 dB BD: -28.4 dB DE: -24.4 dB EF: -17.6 dB transmit ON/OFF time 200ms timing Uncertainty of OFF power measurement is handled by Transmit OFF power test and uncertainty of ON power measurement is handled by Minimum output power test.
5.5.1 Transmit OFF power (static case)	Transmit OFF power shall be less than -56 dBm	1.0 dB	Formula: Transmit OFF power + TT Transmit OFF power = -55dBm.
5.5.2 Transmit ON/OFF time mask (dynamic case)	Transmit ON power shall be the target value as defined in clause 5.5.2.2 Transmit OFF power shall be less than -56 dBm	On power upper TT = 0.7 dB On power lower TT = 1.0 dB Off power TT [] dB	Formula for transmit ON power: Transmit ON power target upper limit + On power upper TT Transmit ON power target lower limit - On power lower TT To calculate Transmit ON power target value range take the nominal TX power range from Table 5.5.2.3 then apply table 5.4.1.1 open limits then apply table 5.7.1 (only if there has been a transmission gap) then cap the upper value using table 5.2.1. Formula for transmit OFF power: Transmit OFF power + Off power TT Transmit OFF power = [] dBm
5.6 Change of TFC: power control step size	TFC step size = +5 to +9 dB	0.3 dB	Formula: Upper Tolerance limit + TT Lower Tolerance limit – TT Upper limit = -4.7 dB Lower limit = -9.3 dB
5.7 Power setting in uplink compressed mode	Various	TBD (Subset of 5.4.2)	TBD

Test	Minimum Requirement in TS 25.101	Test Tolerance (TT)	Test Requirement in TS 34.121		
5.8 Occupied Bandwidth	The occupied channel bandwidth shall be less than 5 MHz based on a chip rate of 3.84 Mcps.	0 kHz	Formula: occupied channel bandwidth: + TT occupied channel bandwidth = 5.0 MHz		
5.9 Spectrum emission mask	Minimum requirement defined in TS25.101 Table 6.10. The lower limit shall be -50 dBm / 3.84 MHz or which ever is higher.	1.5 dB	Formula: Minimum requirement + TT Lower limit + TT Add 1.5 to Minimum requirement entries in TS25.101 Table 6.10. Zero test tolerance is applied for Additional requirements for Band II due to FCC regulatory requirements. The lower limit shall be -48.5 dBm / 3.84 MHz or which ever is higher.		
5.10 Adjacent Channel Leakage Power Ratio (ACLR)	If the adjacent channel power is greater than -50 dBm then the ACLR shall be higher than the values specified below.	0.0 dB	Formula: Absolute power threshold + TT		
	Power Classes 3 and 4: UE channel +5 MHz or -5 MHz, ACLR limit: 33 dB UE channel +10 MHz or -10 MHz, ACLR limit: 43 dB	0.8 dB	Formula: ACLR limit - TT Power Classes 3 and 4: UE channel +5 MHz or -5 MHz, ACLR limit: 32.2 dB UE channel +10 MHz or -10 MHz, ACLR limit: 42.2 dB		
5.11 Spurious Emissions			Formula: Minimum Requirement+ TT Add zero to all the values of Minimum Requirements in table 5.11.1a and 5.11.1b.		
	Frequency Band	Minimum Requirement	Frequency Band	Minimum Requirement	
	9 kHz ≤ f < 150 kHz	-36dBm /1kHz	0 dB	9kHz ≤ f < 1GHz	-36dBm /1kHz
	150 kHz ≤ f < 30 MHz	-36dBm /10kHz	0 dB	150 kHz ≤ f < 30 MHz	-36dBm /10kHz
	30 MHz ≤ f < 1000 MHz	-36dBm /100kHz	0 dB	30 MHz ≤ f < 1000 MHz	-36dBm /100kHz
	1 GHz ≤ f < 12.75 GHz	-30dBm /1MHz	0 dB	1 GHz ≤ f < 2.2 GHz	-30dBm /1MHz
			0 dB	2.2 GHz ≤ f < 4 GHz	-30dBm /1MHz
			0 dB	4 GHz ≤ f < 12.75 GHz	-30dBm /1MHz
	1893.5 MHz < f < 1919.6 MHz	-41dBm /300kHz	0 dB	1893.5 MHz < f < 1919.6 MHz	-41dBm /300kHz
	925 MHz ≤ f ≤ 935 MHz	-67dBm /100kHz	0 dB	925 MHz ≤ f ≤ 935 MHz	-67dBm /100kHz
935 MHz < f ≤ 960 MHz	-79dBm /100kHz	0 dB	935 MHz < f ≤ 960 MHz	-79dBm /100kHz	
1805 MHz ≤ f ≤ 1880 MHz	-71dBm /100kHz	0 dB	1805 MHz ≤ f ≤ 1880 MHz	-71dBm /100kHz	
5.12 Transmit Intermodulation	Intermodulation Product 5MHz -31 dBc 10MHz -41 dBc CW Interferer level = -40 dBc	0 dB	Formula: CW interferer level – TT/2 Intermod Products limits remain unchanged. CW interferer level = -40 dBc		
5.13.1 Transmit modulation: EVM	The measured EVM shall not exceed 17.5%.	0%	Formula: EVM limit + TT EVM limit = 17.5 %		
5.13.2 Transmit modulation: peak code domain error	The measured Peak code domain error shall not exceed -15 dB.	1.0 dB	Formula: Peak code domain error + TT Peak code domain error = -14 dB		

Table F.4.2: Derivation of Test Requirements (Receiver tests)

Test	Minimum Requirement in TS 25.101		Test Tolerance (TT)	Test Requirement in TS 34.121	
6.2 Reference sensitivity level	$\hat{I}_{or} = -106.7 \text{ dBm} / 3.84 \text{ MHz}$ $DPCH_Ec = -117 \text{ dBm} / 3.84 \text{ MHz}$ BER limit = 0.001		0.7 dB	Formula: $\hat{I}_{or} + TT$ $DPCH_Ec + TT$ BER limit unchanged $\hat{I}_{or} = -106 \text{ dBm} / 3.84 \text{ MHz}$ $DPCH_Ec = -116.3 \text{ dBm} / 3.84 \text{ MHz}$	
6.3 Maximum input level	$-25 \text{ dBm } I_{or}$ $-19 \text{ dBc } DPCH_Ec/I_{or}$		0.7 dB	Formula: $I_{or} - TT$ $I_{or} = -25.7 \text{ dBm}$	
6.4 Adjacent Channel Selectivity	$\hat{I}_{or} = -92.7 \text{ dBm} / 3.84 \text{ MHz}$ $DPCH_Ec = -103 \text{ dBm} / 3.84 \text{ MHz}$ $I_{oac} (\text{modulated}) = -52 \text{ dBm} / 3.84 \text{ MHz}$ BER limit = 0.001		0 dB	Formula: \hat{I}_{or} unchanged $DPCH_Ec$ unchanged $I_{oac} - TT$ BER limit unchanged $I_{oac} = -52 \text{ dBm} / 3.84 \text{ MHz}$	
6.5 Blocking Characteristics	See Table 6.5.3 and 6.5.4. in TS34.121 BER limit = 0.001		0 dB	Formula: $I_{\text{blocking}} (\text{modulated}) - TT (\text{dBm} / 3.84 \text{ MHz})$ $I_{\text{blocking}} (\text{CW}) - TT (\text{dBm})$ BER limit unchanged	
6.6 Spurious Response	$I_{\text{blocking}}(\text{CW}) -44 \text{ dBm}$ F_{uw} : Spurious response frequencies BER limit = 0.001		0 dB	Formula: $I_{\text{blocking}} (\text{CW}) - TT (\text{dBm})$ F_{uw} unchanged BER limit unchanged $I_{\text{blocking}}(\text{CW}) = -44 \text{ dBm}$	
6.7 Intermodulation Characteristics	$I_{ow1} (\text{CW}) -46 \text{ dBm}$ $I_{ow2} (\text{modulated}) -46 \text{ dBm} / 3.84 \text{ MHz}$ $F_{uw1} (\text{offset}) 10 \text{ MHz}$ $F_{uw2} (\text{offset}) 20 \text{ MHz}$ $I_{or} = -103.7 \text{ dBm} / 3.84 \text{ MHz}$ $DPCH_Ec = -114 \text{ dBm} / 3.84$ BER limit = 0.001		0 dB	Formula: $I_{or} + TT$ $DPCH_Ec + TT$ I_{ow1} level unchanged I_{ow2} level unchanged BER limit unchanged. $I_{or} = -114 \text{ dBm}$ BER limit. = 0.001	
6.8 Spurious Emissions				Formula: Maximum level + TT Add zero to all the values of Maximum Level in table 6.8.1.	
	Frequency Band	Maximum level		Frequency Band	Maximum level
	$9 \text{ kHz} \leq f < 1 \text{ GHz}$	$-57 \text{ dBm} / 100 \text{ kHz}$	0 dB	$9 \text{ kHz} \leq f < 1 \text{ GHz}$	$-57 \text{ dBm} / 100 \text{ kHz}$
	$1 \text{ GHz} \leq f \leq 12.75 \text{ GHz}$	$-47 \text{ dBm} / 1 \text{ MHz}$	0 dB	$1 \text{ GHz} \leq f \leq 2.2 \text{ GHz}$	$-47 \text{ dBm} / 1 \text{ MHz}$
			0 dB	$2.2 \text{ GHz} < f \leq 4 \text{ GHz}$	$-47 \text{ dBm} / 1 \text{ MHz}$
			0 dB	$4 \text{ GHz} < f \leq 12.75 \text{ GHz}$	$-47 \text{ dBm} / 1 \text{ MHz}$
	$1920 \text{ MHz} \leq f \leq 1980 \text{ MHz}$	$-60 \text{ dBm} / 3.84 \text{ MHz}$	0 dB	$1920 \text{ MHz} \leq f \leq 1980 \text{ MHz}$	$-60 \text{ dBm} / 3.84 \text{ MHz}$
$2110 \text{ MHz} \leq f \leq 2170 \text{ MHz}$	$-60 \text{ dBm} / 3.84 \text{ MHz}$	0 dB	$2110 \text{ MHz} \leq f \leq 2170 \text{ MHz}$	$-60 \text{ dBm} / 3.84 \text{ MHz}$	

Table F.4.3: Derivation of Test Requirements (Performance tests)

Test	Minimum Requirement in TS 25.101	Test Tolerance (TT)	Test Requirement in TS 34.121
7.2 Demodulation of DPCH in static conditions	$\frac{DPCH_E_c}{I_{or}} \text{ -5.5 to -16.6 dB}$ $I_{oc} = -60 \text{ dBm}$ $\hat{I}_{or}/I_{oc} = -1 \text{ dB}$	0.1 dB for $\frac{DPCH_E_c}{I_{or}}$ 0.3 dB for \hat{I}_{or}/I_{oc}	Formulas: $\frac{DPCH_E_c}{I_{or}} = \text{ratio} + \text{TT}$ $\hat{I}_{or}/I_{oc} = \text{ratio} + \text{TT}$ $I_{oc} \text{ unchanged}$ $\hat{I}_{or}/I_{oc} = -0.7 \text{ dB}$ $\frac{DPCH_E_c}{I_{or}} \text{ -5.4 to -16.5 dB:}$
7.3 Demodulation of DPCH in multi-path fading propagation conditions Tests 1-4	$\frac{DPCH_E_c}{I_{or}} \text{ -2.2 to -15.0}$ $I_{oc} = -60 \text{ dBm}$ $\hat{I}_{or}/I_{oc} = 9 \text{ dB to -3 dB}$	0.1 dB for $\frac{DPCH_E_c}{I_{or}}$ 0.6 dB for \hat{I}_{or}/I_{oc}	Formulas: $\frac{DPCH_E_c}{I_{or}} = \text{ratio} + \text{TT}$ $\hat{I}_{or}/I_{oc} + \text{ratio} + \text{TT}$ $I_{oc} \text{ unchanged}$ $\hat{I}_{or}/I_{oc} = 9.6 \text{ to } -2.4 \text{ dB}$ $\frac{DPCH_E_c}{I_{or}} \text{ -2.1 to -14.9 dB:}$
7.3 Demodulation of DPCH in multi-path fading propagation conditions Tests 5-8	$\frac{DPCH_E_c}{I_{or}} \text{ -3.2 to -7.7 dB}$ $I_{oc} = -60 \text{ dBm}$ $\hat{I}_{or}/I_{oc} = 6 \text{ dB to -3 dB}$	0.1 dB for $\frac{DPCH_E_c}{I_{or}}$ 0.6 dB for \hat{I}_{or}/I_{oc}	Formulas: $\frac{DPCH_E_c}{I_{or}} = \text{ratio} + \text{TT}$ $\hat{I}_{or}/I_{oc} = \text{ratio} + \text{TT}$ $I_{oc} \text{ unchanged}$ $\hat{I}_{or}/I_{oc} = 6.6 \text{ to } -2.4 \text{ dB}$ $\frac{DPCH_E_c}{I_{or}} \text{ -3.1 to -7.6 dB:}$
7.3 Demodulation of DPCH in multi-path fading propagation conditions Tests 9-12	$\frac{DPCH_E_c}{I_{or}} \text{ -4.4 to -11.8 dB}$ $I_{oc} = -60 \text{ dBm}$ $\hat{I}_{or}/I_{oc} = 6 \text{ dB to -3 dB}$	0.1 dB for $\frac{DPCH_E_c}{I_{or}}$ 0.6 dB for \hat{I}_{or}/I_{oc}	Formulas: $\frac{DPCH_E_c}{I_{or}} = \text{ratio} + \text{TT}$ $\hat{I}_{or}/I_{oc} = \text{ratio} + \text{TT}$ $I_{oc} \text{ unchanged}$ $\hat{I}_{or}/I_{oc} = 6.6 \text{ to } -2.4 \text{ dB}$ $\frac{DPCH_E_c}{I_{or}} \text{ -4.3 to -11.7 dB:}$

Test	Minimum Requirement in TS 25.101	Test Tolerance (TT)	Test Requirement in TS 34.121
7.3 Demodulation of DPCH in multi-path fading propagation conditions Tests 13-16	$\frac{DPCH_E_c}{I_{or}} -2.2 \text{ to } -15.0 \text{ dB}$ $I_{OC} = -60 \text{ dBm}$ $\hat{I}_{or}/I_{OC} = 9 \text{ dB}$	0.1 dB for $\frac{DPCH_E_c}{I_{or}}$ 0.6 dB for \hat{I}_{or}/I_{OC}	Formulas: $\frac{DPCH_E_c}{I_{or}} = \text{ratio} + \text{TT}$ $\hat{I}_{or}/I_{OC} = \text{ratio} + \text{TT}$ $I_{OC} \text{ unchanged}$ $\hat{I}_{or}/I_{OC} = 9.6$ $\frac{DPCH_E_c}{I_{or}} -2.1 \text{ to } -14.9 \text{ dB:}$
7.3 Demodulation of DPCH in multi-path fading propagation conditions Tests 17-20	$\frac{DPCH_E_c}{I_{or}} -1.4 \text{ to } -8.8 \text{ dB}$ $I_{OC} = -60 \text{ dBm}$ $\hat{I}_{or}/I_{OC} = 6 \text{ to } -3 \text{ dB}$	0.1 dB for $\frac{DPCH_E_c}{I_{or}}$ 0.6 dB for \hat{I}_{or}/I_{OC}	Formulas: $\frac{DPCH_E_c}{I_{or}} = \text{ratio} + \text{TT}$ $\hat{I}_{or}/I_{OC} = \text{ratio} + \text{TT}$ $I_{OC} \text{ unchanged}$ $\hat{I}_{or}/I_{OC} = 6.6 \text{ to } -2.4 \text{ dB}$ $\frac{DPCH_E_c}{I_{or}} -1.3 \text{ to } -8.7 \text{ dB:}$
7.4 Demodulation of DPCH in moving propagation conditions	$\frac{DPCH_E_c}{I_{or}} -10.9 \text{ to } -14.5$ $I_{OC} = -60 \text{ dBm}$ $\hat{I}_{or}/I_{OC} = -1 \text{ dB}$	0.1 dB for $\frac{DPCH_E_c}{I_{or}}$ 0.6 dB for \hat{I}_{or}/I_{OC}	Formulas: $\frac{DPCH_E_c}{I_{or}} = \text{ratio} + \text{TT}$ $\hat{I}_{or}/I_{OC} = \text{ratio} + \text{TT}$ $I_{OC} \text{ unchanged}$ $\hat{I}_{or}/I_{OC} = -0.4 \text{ dB}$ $\frac{DPCH_E_c}{I_{or}} -10.8 \text{ to } -14.4 \text{ dB:}$
7.5 Demodulation of DPCH birth-death propagation conditions	$\frac{DPCH_E_c}{I_{or}} -8.7 \text{ to } -12.6 \text{ dB}$ $I_{OC} = -60 \text{ dBm}$ $\hat{I}_{or}/I_{OC} = -1 \text{ dB}$	0.1 dB for $\frac{DPCH_E_c}{I_{or}}$ 0.6 dB for \hat{I}_{or}/I_{OC}	Formulas: $\frac{DPCH_E_c}{I_{or}} = \text{ratio} + \text{TT}$ $\hat{I}_{or}/I_{OC} = \text{ratio} + \text{TT}$ $I_{OC} \text{ unchanged}$ $\hat{I}_{or}/I_{OC} = -0.4 \text{ dB}$ $\frac{DPCH_E_c}{I_{or}} -18.6 \text{ to } -12.5 \text{ dB:}$

Test	Minimum Requirement in TS 25.101	Test Tolerance (TT)	Test Requirement in TS 34.121
7.6.1 Demodulation of DPCH in transmit diversity propagation conditions	$\frac{DPCH_E_c}{I_{or}} -16.8 \text{ dB}$ $I_{OC} = -60 \text{ dBm}$ $\hat{I}_{or}/I_{oc} = 9 \text{ dB}$	0.1 dB for $\frac{DPCH_E_c}{I_{or}}$ 0.8 dB for \hat{I}_{or}/I_{oc}	Formulas: $\frac{DPCH_E_c}{I_{or}} = \text{ratio} + \text{TT}$ $\hat{I}_{or}/I_{oc} = \text{ratio} + \text{TT}$ $I_{OC} \text{ unchanged}$ $\hat{I}_{or}/I_{oc} = 9.8 \text{ dB}$ $\frac{DPCH_E_c}{I_{or}} -16.7 \text{ dB:}$
7.6.2 Demodulation of DCH in closed loop Transmit diversity mode	$\frac{DPCH_E_c}{I_{or}} -18 \text{ to } -18.3 \text{ dB}$ $I_{OC} = -60 \text{ dBm}$ $\hat{I}_{or}/I_{oc} = 9 \text{ dB}$	0.1 dB for $\frac{DPCH_E_c}{I_{or}}$ 0.8 dB for \hat{I}_{or}/I_{oc}	Formulas: $\frac{DPCH_E_c}{I_{or}} = \text{ratio} + \text{TT}$ $\hat{I}_{or}/I_{oc} = \text{ratio} + \text{TT}$ $I_{OC} \text{ unchanged}$ $\hat{I}_{or}/I_{oc} = 9.8 \text{ dB}$ $\frac{DPCH_E_c}{I_{or}} -17.9 \text{ to } -18.2 \text{ dB:}$
7.6.3, Demodulation of DCH in site selection diversity Transmission power control mode	$\frac{DPCH_E_c}{I_{or}} -7.5 \text{ to } -9.2 \text{ dB}$ $I_{OC} = -60 \text{ dBm}$ $\hat{I}_{or}/I_{oc} = 0 \text{ to } -3 \text{ dB}$	0.1 dB for $\frac{DPCH_E_c}{I_{or}}$ 0.8 dB for \hat{I}_{or}/I_{oc}	Formulas: $\frac{DPCH_E_c}{I_{or}} = \text{ratio} + \text{TT}$ $\hat{I}_{or}/I_{oc} = \text{ratio} + \text{TT}$ $I_{OC} \text{ unchanged}$ $\hat{I}_{or}/I_{oc} = 0.8 \text{ to } -2.2 \text{ dB}$ $\frac{DPCH_E_c}{I_{or}} -7.4 \text{ to } -9.1 \text{ dB:}$
7.7.1 Demodulation in inter-cell soft Handover	$\frac{DPCH_E_c}{I_{or}} -5.5 \text{ to } -15.2 \text{ dB}$ $I_{OC} = -60 \text{ dBm}$ $\hat{I}_{or}/I_{oc} = \text{lor2}/\text{loc} = 6 \text{ to } 0 \text{ dB}$	0.1 dB for $\frac{DPCH_E_c}{I_{or}}$ 0.8 dB for \hat{I}_{or}/I_{oc}	Formulas: $\frac{DPCH_E_c}{I_{or}} = \text{ratio} + \text{TT}$ $\hat{I}_{or}/I_{oc} = \text{ratio} + \text{TT}$ $I_{OC} \text{ unchanged}$ $\hat{I}_{or}/I_{oc} = 6.8 \text{ to } 0.8 \text{ dB}$ $\frac{DPCH_E_c}{I_{or}} -5.4 \text{ to } -15.4 \text{ dB:}$

Test	Minimum Requirement in TS 25.101	Test Tolerance (TT)	Test Requirement in TS 34.121
7.7.2 Combining of TPC commands Test 1	$\frac{DPCH_E_c}{I_{or}} -12 \text{ dB}$ <p>lor1 and lor2 -60dBm</p>	0.1 dB for $\frac{DPCH_E_c}{I_{or}}$ 0dB for lor1 and lor2	Formulas: $\frac{DPCH_E_c}{I_{or}} = \text{ratio} + \text{TT}$ $\frac{DPCH_E_c}{I_{or}} = -11,9 \text{ dB:}$ <p>lor1 = -60dBm lor2 = -60dBm</p> <p>The absolute levels of lor1 and lor2 are not important to this test.</p>
7.7.2 Combining of TPC commands Test 2	$\frac{DPCH_E_c}{I_{or}} -12 \text{ dB}$ <p>$I_{oc} = -60 \text{ dBm}$</p> <p>$\hat{I}_{or}/I_{oc} = 0 \text{ dB}$</p>	0.1 dB for $\frac{DPCH_E_c}{I_{or}}$ 0.8 dB for \hat{I}_{or}/I_{oc}	Formulas: $\frac{DPCH_E_c}{I_{or}} = \text{ratio} + \text{TT}$ $\hat{I}_{or}/I_{oc} = \text{ratio} + \text{TT}$ <p>I_{oc} unchanged</p> <p>$\hat{I}_{or}/I_{oc} = 0.8 \text{ dB}$</p> $\frac{DPCH_E_c}{I_{or}} -11,9 \text{ dB:}$
7.8.1 Power control in downlink constant BLER target	$\frac{DPCH_E_c}{I_{or}} -9 \text{ to } -16 \text{ dB}$ <p>$I_{oc} = -60 \text{ dBm}$</p> <p>$\hat{I}_{or}/I_{oc} = 9 \text{ to } -1 \text{ dB}$</p>	0.1 dB for $\frac{DPCH_E_c}{I_{or}}$ 0.6 dB for \hat{I}_{or}/I_{oc}	Formulas: $\frac{DPCH_E_c}{I_{or}} = \text{ratio} + \text{TT}$ $\hat{I}_{or}/I_{oc} = \text{ratio} + \text{TT}$ <p>I_{oc} unchanged</p> <p>$\hat{I}_{or}/I_{oc} = 9.6 \text{ to } -0.4 \text{ dB}$</p> $\frac{DPCH_E_c}{I_{or}} -8.9 \text{ to } -15.9 \text{ dB:}$
7.8.2, Power control in downlink initial convergence	$\frac{DPCH_E_c}{I_{or}} -8.1 \text{ to } -18.9 \text{ dB}$ <p>$I_{oc} = -60 \text{ dBm}$</p> <p>$\hat{I}_{or}/I_{oc} = -1 \text{ dB}$</p>	0.1 dB for $\frac{DPCH_E_c}{I_{or}}$ 0.6 dB for \hat{I}_{or}/I_{oc}	Formulas: $\frac{DPCH_E_c}{I_{or}} = \text{ratio} + \text{TT}$ $\hat{I}_{or}/I_{oc} = \text{ratio} + \text{TT}$ <p>I_{oc} unchanged</p> <p>$\hat{I}_{or}/I_{oc} = -0.4 \text{ dB}$</p> $\frac{DPCH_E_c}{I_{or}} -8.0 \text{ to } -18.8 \text{ dB:}$

Test	Minimum Requirement in TS 25.101	Test Tolerance (TT)	Test Requirement in TS 34.121
7.8.3, Power control in downlink: wind up effects	$\frac{DPCH_E_c}{I_{or}} -13.3 \text{ dB}$ $I_{OC} = -60 \text{ dBm}$ $\hat{I}_{or}/I_{oc} = 5 \text{ dB}$	0.1 dB for $\frac{DPCH_E_c}{I_{or}}$ 0.6 dB for \hat{I}_{or}/I_{oc}	Formulas: $\frac{DPCH_E_c}{I_{or}} = \text{ratio} + \text{TT}$ $\hat{I}_{or}/I_{oc} = \text{ratio} + \text{TT}$ $I_{OC} \text{ unchanged}$ $\hat{I}_{or}/I_{oc} = 5.6 \text{ dB}$ $\frac{DPCH_E_c}{I_{or}} -13.2 \text{ dB:}$
7.9 Downlink compressed mode	$\frac{DPCH_E_c}{I_{or}}$ Test 1 -14.6 dB Test 3 -15.2 dB $I_{OC} = -60 \text{ dBm}$ $\hat{I}_{or}/I_{oc} = 9 \text{ dB}$	0.1 dB for $\frac{DPCH_E_c}{I_{or}}$ 0.6 dB for \hat{I}_{or}/I_{oc}	Formulas: $\frac{DPCH_E_c}{I_{or}} = \text{ratio} + \text{TT}$ $\hat{I}_{or}/I_{oc} = \text{ratio} + \text{TT}$ $I_{OC} \text{ unchanged}$ $\hat{I}_{or}/I_{oc} = 9.6 \text{ dB}$ $\frac{DPCH_E_c}{I_{or}}$ Test 1 -14.5 dB Test 3 -15.1 dB:
7.10 Blind transport format detection Tests 1, 2, 3	$\frac{DPCH_E_c}{I_{or}} -17.7 \text{ to } -18.4 \text{ dB}$ $I_{OC} = -60 \text{ dBm}$ $\hat{I}_{or}/I_{oc} = -1 \text{ dB}$	0.1 dB for $\frac{DPCH_E_c}{I_{or}}$ 0.3 dB for \hat{I}_{or}/I_{oc}	Formulas: $\frac{DPCH_E_c}{I_{or}} = \text{ratio} + \text{TT}$ $\hat{I}_{or}/I_{oc} = \text{ratio} + \text{TT}$ $I_{OC} \text{ unchanged}$ $\hat{I}_{or}/I_{oc} = -0.7 \text{ dB}$ $\frac{DPCH_E_c}{I_{or}} -17.6 \text{ to } -18.3 \text{ dB:}$
7.10 Blind transport format detection Tests 4, 5, 6	$\frac{DPCH_E_c}{I_{or}} -13.0 \text{ to } -13.8 \text{ dB}$ $I_{OC} = -60 \text{ dBm}$ $\hat{I}_{or}/I_{oc} = -3 \text{ dB}$	0.1 dB for $\frac{DPCH_E_c}{I_{or}}$ 0.6 dB for \hat{I}_{or}/I_{oc}	Formulas: $\frac{DPCH_E_c}{I_{or}} = \text{ratio} + \text{TT}$ $\hat{I}_{or}/I_{oc} = \text{ratio} + \text{TT}$ $I_{OC} \text{ unchanged}$ $\hat{I}_{or}/I_{oc} = -2.4 \text{ dB}$ $\frac{DPCH_E_c}{I_{or}} -12.9 \text{ to } -13.7 \text{ dB:}$

Table F.4.4: Derivation of Test Requirements (RRM tests)

Test	Test Parameters in TS 25.133	Test Tolerance (TT)	Test Requirement in TS 34.121
8.2 Idle Mode Tasks			
8.2.2 Cell Re-Selection			
8.2.2.1 Scenario 1: Single carrier case	$\frac{CPICH_E_c}{I_{or}} = -10$ dB $I_{oc} = -70$ dBm lor/loc = 7.3 dB Note: Parameters are valid for cell 1 at time T1 and cell 2 at time T2	0.1 dB for $\frac{CPICH_E_c}{I_{or}}$ 0.3 dB for lor/loc	Formulas: $\frac{CPICH_E_c}{I_{or}} = \text{ratio} - TT$ lor/loc = ratio - TT I_{oc} unchanged lor/loc = 7 dB $\frac{CPICH_E_c}{I_{or}} -10.1$ dB:
	$\frac{CPICH_E_c}{I_{or}} = -10$ dB $I_{oc} = -70$ dBm lor/loc = 10.27 dB Note: Parameters are valid for cell 1 at time T2 and cell 2 at time T1	0.1 dB for $\frac{CPICH_E_c}{I_{or}}$ 0.3 dB for lor/loc	Formulas: $\frac{CPICH_E_c}{I_{or}} = \text{ratio} + TT$ lor/loc = ratio + TT loc unchanged lor/loc = 10.57 dB $\frac{CPICH_E_c}{I_{or}} -9.9$ dB:
8.2.2.2 Scenario 2: Multi carrier case	$\frac{CPICH_E_c}{I_{or}} = -10$ dB $I_{oc} = -70$ dBm lor/loc = -3.4 dB Note: Parameters are valid for cell 1 at time T1 and cell 2 at time T2	0.1 dB for $\frac{CPICH_E_c}{I_{or}}$ 0.3 dB for lor/loc	Formulas: $\frac{CPICH_E_c}{I_{or}} = \text{ratio} - TT$ lor/loc = ratio - TT loc unchanged loc ratio unchanged lor/loc = -3.7 dB $\frac{CPICH_E_c}{I_{or}} -10.1$ dB:

Test	Test Parameters in TS 25.133	Test Tolerance (TT)	Test Requirement in TS 34.121
	$\frac{CPICH_E_c}{I_{or}} = -10$ dB $I_{oc} = -70$ dBm lor/loc = 2.2 dB Note: Parameters are valid for cell 1 at time T2 and cell 2 at time T1	0.1 dB for $\frac{CPICH_E_c}{I_{or}}$ 0.3 dB for lor/loc 0.3 dB for loc/RXLEV	Formulas: $\frac{CPICH_E_c}{I_{or}} = \text{ratio} + TT$ lor/loc = ratio + TT loc unchanged loc ratio unchanged lor/loc = 2.5 dB $\frac{CPICH_E_c}{I_{or}} -9.9$ dB:
8.2.3 UTRAN to GSM Cell Re-Selection	TBD		
8.2.3.1 Scenario 1: Both UTRA and GSM level changed	$\frac{CPICH_E_c}{I_{or}} = -10$ dB lor/loc = 0 dB	0.1 dB for $\frac{CPICH_E_c}{I_{or}}$ 0.3 dB for lor/loc 0.3 dB for loc/RXLEV	Formulas: $\frac{CPICH_E_c}{I_{or}} = \text{ratio} + TT$ lor/loc = ratio + TT $(\text{loc/Rxlev})_{\text{test requirement}} = (\text{loc/Rxlev})_{\text{minimum requirement}} + TT$ lor/loc = 0.3 dB $\frac{CPICH_E_c}{I_{or}} = -9.9$ dB:
	$\frac{CPICH_E_c}{I_{or}} = -10$ dB lor/loc = -5 dB	0.1 dB for $\frac{CPICH_E_c}{I_{or}}$ 0.3 dB for lor/loc 0.3 dB for loc/RXLEV	Formulas: $\frac{CPICH_E_c}{I_{or}} = \text{ratio} - TT$ lor/loc = ratio - TT $(\text{loc/Rxlev})_{\text{test requirement}} = (\text{loc/Rxlev})_{\text{minimum requirement}} - TT$ lor/loc = -5.3 dB $\frac{CPICH_E_c}{I_{or}} -10.1$ dB:
8.2.3.2 Scenario 2: Only UTRA level changed	$\frac{CPICH_E_c}{I_{or}} = -10$ dB lor/loc = 20 dB	0.1 dB for $\frac{CPICH_E_c}{I_{or}}$ 0.3 dB for lor/loc 0.3 dB for loc/RXLEV	Formulas: $\frac{CPICH_E_c}{I_{or}} = \text{ratio} + TT$ lor/loc = ratio + TT $(\text{loc/Rxlev})_{\text{test requirement}} = (\text{loc/Rxlev})_{\text{minimum requirement}} + TT$ lor/loc = 20.3 dB $\frac{CPICH_E_c}{I_{or}} = -9.9$ dB:

Test	Test Parameters in TS 25.133	Test Tolerance (TT)	Test Requirement in TS 34.121
	$\frac{CPICH_E_c}{I_{or}} = -10 \text{ dB}$ lor/loc = 20 dB	0.1 dB for $\frac{CPICH_E_c}{I_{or}}$ 0.3 dB for lor/loc 0.3 dB for loc/RXLEV	Formulas: $\frac{CPICH_E_c}{I_{or}} = \text{ratio} + TT$ lor/loc = ratio + TT (loc/Rxlev) _{test requirement} = (loc/Rxlev) _{minimum requirement} + TT lor/loc = 20.3 dB $\frac{CPICH_E_c}{I_{or}} = -9.9 \text{ dB:}$
8.2.4 FDD/TDD cell re-selection	TBD		
8.3 UTRAN Connected Mode Mobility	TBD		
8.3.1 FDD/FDD Soft Handover	TBD		
8.3.2 FDD/FDD Hard Handover	TBD		
8.3.3 FDD/TDD Handover	TBD		
8.3.4 Inter-system Handover form UTRAN FDD to GSM	TBD		
8.3.5 Cell Re-selection in CELL_FACH			
8.3.5.1 One frequency present in the neighbour list	$\frac{CPICH_E_c}{I_{or}} = -10 \text{ dB}$ $I_{oc} = -70 \text{ dBm}$ lor/loc = 7.3 dB Note: Parameters are valid for cell 1 at time T1 and cell 2 at time T2	0.1 dB for $\frac{CPICH_E_c}{I_{or}}$ 0.3 dB for lor/loc	Formulas: $\frac{CPICH_E_c}{I_{or}} = \text{ratio} - TT$ lor/loc = ratio - TT I_{oc} unchanged lor/loc = 7 dB $\frac{CPICH_E_c}{I_{or}} -10.1 \text{ dB:}$
	$\frac{CPICH_E_c}{I_{or}} = -10 \text{ dB}$ $I_{oc} = -70 \text{ dBm}$ lor/loc = 10.27 dB Note: Parameters are valid for cell 1 at time T2 and cell 2 at time T1	0.1 dB for $\frac{CPICH_E_c}{I_{or}}$ 0.3 dB for lor/loc	Formulas: $\frac{CPICH_E_c}{I_{or}} = \text{ratio} + TT$ lor/loc = ratio + TT loc unchanged lor/loc = 10.57 dB $\frac{CPICH_E_c}{I_{or}} -9.9 \text{ dB:}$

Test	Test Parameters in TS 25.133	Test Tolerance (TT)	Test Requirement in TS 34.121
8.3.5.2 Two frequencies present in the neighbour list	$\frac{CPICH_E_c}{I_{or}} = -10$ dB $I_{oc} = -70$ dBm lor/loc = -3.4 dB Note: Parameters are valid for cell 1 at time T1 and cell 2 at time T2	0.1 dB for $\frac{CPICH_E_c}{I_{or}}$ 0.3 dB for lor/loc	Formulas: $\frac{CPICH_E_c}{I_{or}} = \text{ratio} - TT$ lor/loc = ratio - TT loc unchanged loc ratio unchanged lor/loc = -3.7 dB $\frac{CPICH_E_c}{I_{or}} -10.1$ dB:
	$\frac{CPICH_E_c}{I_{or}} = -10$ dB $I_{oc} = -70$ dBm lor/loc = 2.2 dB Note: Parameters are valid for cell 1 at time T2 and cell 2 at time T1	0.1 dB for $\frac{CPICH_E_c}{I_{or}}$ 0.3 dB for lor/loc	Formulas: $\frac{CPICH_E_c}{I_{or}} = \text{ratio} + TT$ lor/loc = ratio + TT loc unchanged loc ratio unchanged lor/loc = 2.5 dB $\frac{CPICH_E_c}{I_{or}} -9.9$ dB:
8.3.6 Cell Re-selection in CELL_PCH			
8.3.6.1 One frequency present in the neighbour list	$\frac{CPICH_E_c}{I_{or}} = -10$ dB $I_{oc} = -70$ dBm lor/loc = 7.3 dB Note: Parameters are valid for cell 1 at time T1 and cell 2 at time T2	0.1 dB for $\frac{CPICH_E_c}{I_{or}}$ 0.3 dB for lor/loc	Formulas: $\frac{CPICH_E_c}{I_{or}} = \text{ratio} - TT$ lor/loc = ratio - TT I_{oc} unchanged lor/loc = 7 dB $\frac{CPICH_E_c}{I_{or}} -10.1$ dB:

Test	Test Parameters in TS 25.133	Test Tolerance (TT)	Test Requirement in TS 34.121
	$\frac{CPICH_E_c}{I_{or}} = -10 \text{ dB}$ $I_{oc} = -70 \text{ dBm}$ <p>lor/loc = 10.27 dB</p> <p>Note: Parameters are valid for cell 1 at time T2 and cell 2 at time T1</p>	0.1 dB for $\frac{CPICH_E_c}{I_{or}}$ 0.3 dB for lor/loc	Formulas: $\frac{CPICH_E_c}{I_{or}} = \text{ratio} + TT$ <p>lor/loc = ratio + TT</p> <p>loc unchanged</p> <p>lor/loc = 10.57 dB</p> $\frac{CPICH_E_c}{I_{or}} -9.9 \text{ dB:}$
8.3.6.2 Two frequencies present in the neighbour list	$\frac{CPICH_E_c}{I_{or}} = -10 \text{ dB}$ $I_{oc} = -70 \text{ dBm}$ <p>lor/loc = -3.4 dB</p> <p>Note: Parameters are valid for cell 1 at time T1 and cell 2 at time T2</p>	0.1 dB for $\frac{CPICH_E_c}{I_{or}}$ 0.3 dB for lor/loc	Formulas: $\frac{CPICH_E_c}{I_{or}} = \text{ratio} - TT$ <p>lor/loc = ratio - TT</p> <p>loc unchanged</p> <p>loc ratio unchanged</p> <p>lor/loc = -3.7 dB</p> $\frac{CPICH_E_c}{I_{or}} -10.1 \text{ dB:}$
	$\frac{CPICH_E_c}{I_{or}} = -10 \text{ dB}$ $I_{oc} = -70 \text{ dBm}$ <p>lor/loc = 2.2 dB</p> <p>Note: Parameters are valid for cell 1 at time T2 and cell 2 at time T1</p>	0.1 dB for $\frac{CPICH_E_c}{I_{or}}$ 0.3 dB for lor/loc	Formulas: $\frac{CPICH_E_c}{I_{or}} = \text{ratio} + TT$ <p>lor/loc = ratio + TT</p> <p>loc unchanged</p> <p>loc ratio unchanged</p> <p>lor/loc = 2.5 dB</p> $\frac{CPICH_E_c}{I_{or}} -9.9 \text{ dB:}$
8.3.7 Cell Re-selection in URA_PCH			

Test	Test Parameters in TS 25.133	Test Tolerance (TT)	Test Requirement in TS 34.121
<p>8.3.7.1 One frequency present in the neighbour list</p>	$\frac{CPICH_E_c}{I_{or}} = -10 \text{ dB}$ <p>$I_{oc} = -70 \text{ dBm}$</p> <p>lor/loc = 7.3 dB</p> <p>Note: Parameters are valid for cell 1 at time T1 and cell 2 at time T2</p>	<p>0.1 dB for $\frac{CPICH_E_c}{I_{or}}$</p> <p>0.3 dB for lor/loc</p>	<p>Formulas:</p> $\frac{CPICH_E_c}{I_{or}} = \text{ratio} - TT$ <p>lor/loc = ratio - TT</p> <p>I_{oc} unchanged</p> <p>lor/loc = 7 dB</p> $\frac{CPICH_E_c}{I_{or}} - 10.1 \text{ dB:}$
	$\frac{CPICH_E_c}{I_{or}} = -10 \text{ dB}$ <p>$I_{oc} = -70 \text{ dBm}$</p> <p>lor/loc = 10.27 dB</p> <p>Note: Parameters are valid for cell 1 at time T2 and cell 2 at time T1</p>	<p>0.1 dB for $\frac{CPICH_E_c}{I_{or}}$</p> <p>0.3 dB for lor/loc</p>	<p>Formulas:</p> $\frac{CPICH_E_c}{I_{or}} = \text{ratio} + TT$ <p>lor/loc = ratio + TT</p> <p>loc unchanged</p> <p>lor/loc = 10.57 dB</p> $\frac{CPICH_E_c}{I_{or}} - 9.9 \text{ dB:}$
<p>8.3.7.2 Two frequencies present in the neighbour list</p>	$\frac{CPICH_E_c}{I_{or}} = -10 \text{ dB}$ <p>$I_{oc} = -70 \text{ dBm}$</p> <p>lor/loc = -3.4 dB</p> <p>Note: Parameters are valid for cell 1 at time T1 and cell 2 at time T2</p>	<p>0.1 dB for $\frac{CPICH_E_c}{I_{or}}$</p> <p>0.3 dB for lor/loc</p>	<p>Formulas:</p> $\frac{CPICH_E_c}{I_{or}} = \text{ratio} - TT$ <p>lor/loc = ratio - TT</p> <p>loc unchanged</p> <p>loc ratio unchanged</p> <p>lor/loc = -3.7 dB</p> $\frac{CPICH_E_c}{I_{or}} - 10.1 \text{ dB:}$

Test	Test Parameters in TS 25.133	Test Tolerance (TT)	Test Requirement in TS 34.121
	$\frac{CPICH_E_c}{I_{or}} = -10$ dB $I_{oc} = -70$ dBm lor/loc = 2.2 dB Note: Parameters are valid for cell 1 at time T2 and cell 2 at time T1	0.1 dB for $\frac{CPICH_E_c}{I_{or}}$ 0.3 dB for lor/loc	Formulas: $\frac{CPICH_E_c}{I_{or}} = \text{ratio} + TT$ lor/loc = ratio + TT loc unchanged loc ratio unchanged lor/loc = 2.5 dB $\frac{CPICH_E_c}{I_{or}} -9.9$ dB:
8.4 RRC Connection Control	TBD		
8.4.1 RRC Re-establishment delay	TBD		
8.4.2 Random Access	TBD		
8.5 Timing and Signalling Characteristics	TBD		
8.5.1 UE Transmit Timing	TBD		
8.6 UE Measurements Procedures	TBD		
8.6.1 FDD intra frequency measurements	TBD		
8.6.1.1 Event triggered reporting in AWGN propagation conditions	TBD		
8.6.1.2 Event triggered reporting of multiple neighbours in AWGN propagation condition	TBD		
8.6.1.3 Event triggered reporting of two detectable neighbours in AWGN propagation condition	TBD		
8.6.1.4 Correct reporting of neighbours in fading propagation condition	TBD		
8.6.2 FDD inter frequency measurements	TBD		
8.6.2.1 Correct reporting of neighbours in AWGN propagation condition	TBD		
8.6.2.2 Correct reporting of neighbours in Fading propagation condition	TBD		
8.6.3 TDD measurements	TBD		
8.6.3.1 Correct reporting of TDD neighbours in AWGN propagation condition	TBD		

Test	Test Parameters in TS 25.133	Test Tolerance (TT)	Test Requirement in TS 34.121
8.7 Measurements Performance Requirements	TBD		
8.7.1 CPICH RSCP	TBD		
8.7.1.1 Intra frequency measurements accuracy	TBD		
8.7.1.2 Inter frequency measurement accuracy	TBD		
8.7.2 CPICH Ec/Io	TBD		
8.7.1.1 Intra frequency measurements accuracy	TBD		
8.7.1.2 Inter frequency measurement accuracy	TBD		
8.7.3A UTRA Carrier RSSI	TBD		
8.7.3B Transport channel BLER	TBD		
8.7.3C UE Transmitted power	Accuracy upper limit Accuracy lower limit Depends on PUEMAX see table 8.7.3C.2.1	0.7 dB	Formula: Upper accuracy limit + TT Lower accuracy limit – TT Add and subtract TT to all the values in table 8.7.3C.2.1.
8.7.4 SFN-CFN observed time difference	TBD		
8.7.5 SFN-SFN observed time difference	TBD		
8.7.6 UE Rx-Tx time difference	$Io - 10.9 \text{ dB} = loc$, Test 1: $Io = -94 \text{ dBm}$ Test2 : $Io = -72 \text{ dBm}$ Test3 : $Io = -50 \text{ dBm}$ Timing Accuracy ± 1.5 chip	1 dB for loc 0.3 dB for Ior/loc [0.5 chip for timing accuracy]	Test 1: $Io = -92.7 \text{ dBm}$, $loc = -103.6 \text{ dBm}$ Formula: $loc * (1 - TT_{loc} + (Ior/loc - TT_{Ior/loc})) \geq -94$ Test 2: unchanged (no critical RF parameters) Test 3: $Io = -51.3 \text{ dBm}$, $loc = -62.2 \text{ dBm}$ Formula: $loc * (1 + TT_{loc} + (Ior/loc + TT_{Ior/loc})) \leq -50$ Timing accuracy [± 2.0] chip Formulas: Upper limit +TT Lower limit –TT
8.7.7 Observed time difference to GSM cell	TBD		
8.7.8 P-CCPCH RSCP	TBD		

F.5 Acceptable uncertainty of Test Equipment (This clause is informative)

This informative clause specifies the critical parameters of the components of an overall Test System (e.g. Signal generators, Signal Analysers etc.) which are necessary when assembling a Test System that complies with clause F.1 Acceptable Uncertainty of Test System. These Test Equipment parameters are fundamental to the accuracy of the overall Test System and are unlikely to be improved upon through System Calibration.

F.5.1 Transmitter measurements

Table F.5.1: Equipment accuracy for transmitter measurements

Test	Equipment accuracy	Test conditions
5.2 Maximum Output Power	Not critical	19 to 25 dBm
5.3 Frequency error	± 10 Hz	0 to 500 Hz.
5.4.1 Open loop power control in uplink	Not critical	-43.7 dBm to 25 dBm
5.4.2 Inner loop power control in the uplink – single step	±0.1 dB relative over a 1.5 dB range ±0.15 dB relative over a 3.0 range ±0.2 dB relative over a 4.5 dB range	+25 dBm to -50 dBm
5.4.2 Inner loop power control in the uplink – seven and ten steps	±0.3 dB relative over a 26 dB range	+25 dBm to -50 dBm
5.4.3 Minimum Output Power	Not critical	
5.4.4 Out-of-synchronisation handling of output power: $\frac{DPCCH - E_c}{I_{or}}$	±0.1 dB uncertainty in DPCCH_Ec/Ior ratio	Ratio from -16.6 dB to -28 dB
5.5.1 Transmit ON/OFF Power: UE transmit OFF power	Not critical	-56 dBm (static power)
5.5.2 Transmit ON/OFF Power: transmit ON/OFF time mask	TBD	-56 dBm (dynamic power over approx. 70 dB range)
5.6 Change of TFC: power control step size	±0.3 dB relative over a 9 dB range	+25 dBm to -50 dBm
5.7 Power setting in uplink compressed mode:-UE output power	Subset of 5.4.2	+25 dBm to -50 dBm
5.8 Occupied Bandwidth	±100 kHz	For results between 4 and 6 MHz?
5.9 Spectrum emission mask	Not critical	P_Max Accuracy applies ± 5 dB either side of UE requirements
5.10 ACLR	5 MHz offset ± 0.8 dB 10 MHz offset ± 0.8 dB	19 to 25 dBm at 5 MHz offset for results between 40 dB and 50 dB. 25 dBm at 10 MHz offset for results between 45 dB and 55 dB.
5.11 Spurious emissions	Not critical	19 to 25 dBm
5.12 Transmit Intermodulation	Not critical	19 to 25 dBm
5.13.1 Transmit modulation: EVM	±2.5 % (for single code)	25 dBm to -21 dBm
5.13.2 Transmit modulation: peak code domain error	±1.0dB	For readings between -10 dB to -20 dB.

F.5.2 Receiver measurements

Table F.5.2: Equipment accuracy for receiver measurements

Clause	Equipment accuracy	Test conditions
6.2 Reference sensitivity level	Not critical	
6.3 Maximum input level:	Not critical	
6.4 Adjacent channel selectivity	Not critical	
6.5 Blocking characteristics	Not critical	
6.6 Spurious Response	Not critical	
6.7 Intermod Characteristics	Not critical	
6.8 Spurious emissions	Not critical	

F.5.3 Performance measurements

Table G.3: Equipment accuracy for performance measurements

Clause	Equipment accuracy	Test conditions
7.2 to 7.10	$\frac{DPCH - E_c}{I_{or}} \pm 0.1 \text{ dB}$	-2.2 to -18.9 dB

F.6 General rules for statistical testing

F.6.1 Statistical testing of receiver BER/BLER performance

F.6.1.1 Error Definition

1) Bit Error Ratio (BER)

The Bit Error Ratio is defined as the ratio of the bits wrongly received to all data bits sent. The bits are the information bits above the convolutional/turbo decoder

2) Block Error Ratio (BLER)

A Block Error Ratio is defined as the ratio of the number of erroneous blocks received to the total number of blocks sent. An erroneous block is defined as a Transport Block, the cyclic redundancy check (CRC) of which is wrong.

F.6.1.2 Test Method

Each test is performed in the following manner:

- a) Setup the required test conditions.
- b) Record the number of samples tested and the number of occurred events (bit error or block error)
- c) Stop the test at a stop criterion which is minimum test time or an early pass or an early fail event.
- d) Once the test is stopped decide according to the pass fail decision rules (subclause F.6.1.7)

F.6.1.3 Test Criteria

The test shall fulfil the following requirements:

- a) good pass fail decision
 - 1) to keep reasonably low the probability (risk) of passing a bad unit for each individual test;
 - 2) to have high probability of passing a good unit for each individual test;
- b) good balance between testtime and statistical significance
 - 3) to perform measurements with a high degree of statistical significance;
 - 4) to keep the test time as low as possible.

F.6.1.4 Calculation assumptions

F.6.1.4.1 Statistical independence

- (a) It is assumed, that error events are rare ($\lim \text{BER BLER} \rightarrow 0$) independent statistical events. However the memory of the convolutional /turbo coder is terminated after one TTI. Samples and errors are summed up every TTI. So the assumption of independent error events is justified.
- (b) In the BLER test with fading there is the memory of the multipath fading channel which interferes the statistical independence. A minimum test time is introduced to average fluctuations of the multipath fading channel. So the assumption of independent error events is justified approximately.

F.6.1.4.2 Applied formulas

The formulas, applied to describe the BER BLER test, are based on the following experiments:

- (1) After having observed a certain number of errors (**ne**) the number of samples are counted to calculate BER BLER. Provisions are made (note 1) such that the complementary experiment is valid as well:
- (2) After a certain number of samples (**ns**) the number of errors, occurred, are counted to calculate BER BLER.

Experiment (1) stipulates to use the following Chi Square Distribution with degree of freedom ne : $2 * \text{dchisq}(2 * NE, 2 * ne)$.

Experiment (2) stipulates to use the Poisson Distribution: $\text{dpois}(ne, NE)$

(NE: mean of the distribution)

To determine the early stop conditions, the following inverse cumulative operation is applied:

$0.5 * \text{qchisq}(D, 2 * ne)$. This is applicable for experiment (1) and (2).

D: wrong decision risk per test step

Note: other inverse cumulative operations are available, however only this is suited for experiment (1) and (2).

F.6.1.4.3 Approximation of the distribution

The test procedure is as follows:

During a running measurement for a UE ns (number of samples) and ne (number of errors) are accumulated and from this the preliminary BER BLER is calculated. Then new samples up to the next error are taken. The entire past and the new samples are basis for the next preliminary BER BLER. Depending on the result at every step, the UE can pass, can fail or must continue the test.

As early pass- and early fail-UEs leave the statistical totality under consideration, the experimental conditions are changed every step resulting in a distribution that is truncated more and more towards the end of the entire test. Such a distribution can not any more be handled analytically. The unchanged distribution is used as an approximation to calculate the early fail and early pass bounds.

F.6.1.5 Definition of good pass fail decision.

This is defined by the probability of wrong decision F at the end of the test. The probability of a correct decision is $1-F$.

The probability (risk) to fail a good DUT shall be $\leq F$ according to the following definition: A DUT is failed, accepting a probability of $\leq F$ that the DUT is still better than the specified error ratio (Test requirement).

The probability to pass a bad DUT shall be $\leq F$ according to the following definition: A DUT is passed, accepting a probability of $\leq F$ that the DUT is still worse than M times the specified error ratio. ($M > 1$ is the bad DUT factor).

These definitions lead to an early pass and an early fail limit:

Early fail: $ber \geq berlim_{fail}$

$$berlim_{fail}(D, ne) = \frac{2 * ne}{qchisq(D, 2 * ne)} \quad (1)$$

For $ne \geq [7]$

Early pass: $ber \leq berlim_{pass}$

$$berlim_{pass}(D, ne) = \frac{2 * ne * M}{qchisq(1 - D, 2 * ne)} \quad (2)$$

For $ne \geq 1$

With

ber (normalized BER, BLER): BER, BLER according to F.6.1.1 divided by Test requirement

D : wrong decision probability for a test step. This is a numerically evaluated fraction of F , the wrong decision probability at the end of the test. See table F.6.1.6.1.

ne : Number of error events

M : bad DUT factor see table F.6.1.6.1.

$qchisq$: inverse cumulative chi squared distribution

F.6.1.6 Good balance between testtime and statistical significance

Three independent test parameters are introduced into the test and shown in Table F.6.1.6.1. These are the obvious basis of test time and statistical significance. From the first two of them four dependent test parameters are derived. The third independent test parameter is justified separately.

Table F.6.1.6.1 independent and dependent test parameters

Independent test parameters			Dependent test parameters		
Test Parameter	Value	Reference	Test parameter	Value	Reference
Bad DUT factor M	[1.5]	Table F.6.1.8	Early pass/fail condition	Curves	Subclause F.6.1.5 Figure 6.1.9
Final probability of wrong pass/fail decision F	[0.2%] [0.02%, note 2]	Subclause F.6.1.5	Target number of error events	[345]	Table 6.1.8
			Probability of wrong pass/fail decision per test step D	[0.0085%] [0.0008% and 0.008%, note 2]	
			Test limit factor TL	[1.234]	Table 6.1.8
Minimum test time		Table F.6.1.6.2			

The minimum test time is derived from the following justification:

- 1) For no propagation conditions and static propagation condition

No early fail calculated from fractional number of errors <1 (see note 1)

- 2) For multipath fading condition

No stop of the test until 990 wavelengths are crossed with the speed given in the fading profile.

- 3) For birth death propagation conditions

No stop of the test until 200 birth death transitions occur

- 4) For moving propagation conditions: 628 sec

This is necessary in order to pass all potential critical points in the moving propagation profile 4 times:

Maximum rake window

Maximum adjustment speed

Intersection of moving taps

Table F.6.1.6.2 : minimum Test time

Fading profile	Minimum test time
Multipath propagation 3 km/h	164 sec
Multipath propagation 50 km/h	9.8 sec
Multipath propagation 120 km/h	4.1 sec
Multipath propagation 250 km/h	2 sec
Birth Death propagation	38.2 sec
Moving propagation	628 sec

In table F.6.1.8 the minimum test time is converted in minimum number of samples.

F.6.1.7 Pass fail decision rules

No decision is allowed before the minimum test time is elapsed.

- 1) If minimum Test time < time for target number of error events then the following applies: The required confidence level $1-F$ (= correct decision probability) shall be achieved. This is fulfilled at an early pass or early fail event.

For BER:

For every TTI (Transmit Time Interval) sum up the number of bits (ns) and the number of errors (ne) from the beginning of the test and calculate

BER_1 (including the artificial error at the beginning of the test (Note 1)) and
 BER_0 (excluding the artificial error at the beginning of the test (Note 1)).

If BER_0 is above the early fail limit, fail the DUT.

If BER_1 is below the early pass limit, pass the DUT.

Otherwise continue the test

For BLER:

For every block sum up the number of blocks (ns) and the number of erroneous blocks (ne) from the beginning of the test and calculate

$BLER_1$ (including the artificial error at the beginning of the test (Note 1)) and

$BLER_0$ (excluding the artificial error at the beginning of the test (Note 1)).

If $BLER_1$ is below the early pass limit, pass the DUT.

If $BLER_0$ is above the early fail limit, fail the DUT.

Otherwise continue the test

- 2) If the minimum test time \geq time for target error events, then the test runs for the minimum test time and the decision is done by comparing the result with the test limit.

For BER:

For every TTI (Transmit Time Interval) sum up the number of bits (ns) and the number of errors (ne) from the beginning of the test and calculate BER_0

For BLER:

For every block sum up the number of blocks (ns) and the number of erroneous blocks (ne) from the beginning of the test and calculate $BLER_0$

If $BER_0/BLER_0$ is above the test limit, fail the DUT.

If $BER_0/BLER_0$ is on or below the test limit, pass the DUT.

F.6.1.8 Test conditions for BER, BLER tests

Table F.6.1.8: Test conditions for a single BER/BLER tests

Type of test (BER)	Test requirement (BER/BLER)	Test limit (BER/BLER) = Test requirement (BER/BLER) x TL TL	Target number of error events (time)	Minimum number of samples	Prob that good unit will fail = Prob that bad unit will pass [%]	Bad unit BER/BLER factor M
Reference Sensitivity Level	0.001	[1.234]	[345] (22.9s)	Note 1	[0.2]	[1.5]
Maximum Input Level	0.001	[1.234]	[345] (22.9s)	Note 1	[0.2]	[1.5]
Adjacent Channel Selectivity	0.001	[1.234]	[345] (22.9s)	Note 1	[0.2]	[1.5]
Blocking Characteristics Pass condition Note 2	0.001	[1.251]	[403] (26.4s)	Note 1	[0.2]	[1.5]
Blocking Characteristics Fail condition Note 2	0.001	[1.251]	[403] (26.4s)	Note 1	[0.02]	[1.5]
Spurious Response	0.001	[1.234]	[345] (22.9s)	Note 1	[0.2]	[1.5]
Intermodulation Characteristics	0.001	[1.234]	[345] (22.9s)	Note 1	[0.2]	[1.5]

Table F.6.1.8-2: Test conditions for BLER tests

Type of test (BLER)	Information Bit rate	Test requirement (BER/BLER)	Test limit (BER/BLER)= Test requirement (BER/BLER)x TL TL	Target number of error events (time)	Minimum number of samples	Prob that bad unit will pass = Prob that good unit will fail [%]	Bad unit BER/BLER factor M
Demodulation in Static Propagation conditions	12.2 64 144 384	0.01 0.1 0.01 0.1 0.01	[1.234]	[345] (559.16s) (55.92s) (559.16s) (55.92s) (559.16s) (27.96s) (279.58s)	Note1	[0.2]	[1.5]
Demodulation of DCH in Multi-path Fading Propagation conditions							
3km/h (Case 1, Case 2, Case 4)	12.2 64 144 384	0.01 0.1 0.01 0.1 0.01 0.1 0.01	[1.234]	[345] (559.16s) (55.92s) (559.16s) (55.92s) (559.16s) (27.96s) (279.58s)	[8200] [8200] [8200] [8200] [8200] [16400] [16400]	[0.2]	[1.5]
120 km/h (Case3)	12.2 64 144 384	0.01 0.1 0.01 0.1 0.01 0.1 0.01	[1.234]	[345] (559.16s) (55.92s) (559.16s) (55.92s) (559.16s) (27.96s) (279.58s)	[205] [205] [205] [205] [205] [410] [410]	[0.2]	[1.5]
250 km/h (Case 6)	12.2 64 144 384	0.01 0.1 0.01 0.1 0.01 0.1 0.01	[1.234]	[345] (559.16s) (55.92s) (559.16s) (55.92s) (559.16s) (27.96s) (279.58s)	[100] [100] [100] [100] [100] [200] [200]	[0.2]	[1.5]
Demodulation of DCH in Moving Propagation conditions	12.2 64	0.01 0.01	[1.234]	[345] (559.16)	[31400] [31400]	[0.2]	[1.5]
Demodulation of DCH in Birth-Death Propagation conditions	12.2 64	0.01 0.01	[1.234]	[345] (559.16s) (559.16s)	[1910] [1910]	[0.2]	[1.5]
Demodulation of DCH in Base Station Transmit diversity modes (3 km/h, case1)	12.2	0.01	[1.234]	[345] (559.16s)	[8200]	[0.2]	[1.5]

Demodulation of DCH in closed loop transmit diversity mode (3 km/h, case1) Mode 1	12.2	0.01	[1.234]	[345] (559.16s)	[8200]	[0.2]	[1.5]	
Mode 2	12.2	0.01		(559.16s)	[8200]			
Demodulation of DCH in Site Selection Diversity Transmission Power Control mode	12.2	0.01	[1.234]	[345] (559.16)	[8200]	[0.2]	[1.5]	
Demodulation of DCH in Inter-Cell Soft Handover (120 km/h, case3)	12.2 64 144 384	0.01 0.1 0.01 0.1 0.01 0.1	[1.234]	[345] (559.16s) (55.92s) (559.16s) (55.92s) (559.16s) (27.96s) (279.58s)	[205] [205] [205] [205] [205] [410] [410]	[0.2]	[1.5]	
Combining of TPC commands from radio links of different radio link sets				Not applicable				
Power control in the downlink, constant BLER target				Not applicable				
Power control in the downlink, initial convergence				Not applicable				
Power control in the downlink, wind up effects				Not applicable				
Downlink compressed mode				Not applicable				
Blind transport format detection	Static 12.2 7.95 1.95 Multipath 12.2 7.95 1.98	BLER 10^{-2} 10^{-2} 10^{-2} 10^{-2} 10^{-2} 10^{-2}	FDR 10^{-4} 10^{-4} 10^{-4} 10^{-4} 10^{-4} 10^{-4}	[1.234]	[345] BLER FDR 559.16s 932min 559.16s 932min 559.16s 932min 559.16s 932min 559.16s 932min 559.16s 932min	Note 1 Note 1 Note 1 [205] [205] [205]	[0.2]	[1.5]

F.6.1.9 Practical Use (informative)

See figure F.6.1.9:

The early fail limit represents formula (1) in F.6.1.5. The range of validity is [$n_e \geq 7$, ≥ 8 in case of blocking test] to [$n_e = 345$]

The early pass limit represents the formula (2) in F.6.1.5. The range of validity is $n_e = 1$ to [$n_e = 345$]. See note 1

The intersection co-ordinates of both curves are : number of errors $n_e = [345]$ and test limit $TL = [1.234]$.

The range of validity for TL is $n_e > 345$.

A typical BER BLER test, calculated from the number of samples and errors (F.6.1.2.(b)) using experimental method (1) or (2) (see F.6.1.4. calculation assumptions) runs along the yellow trajectory. With an errorless sample the trajectory goes down vertically. With an erroneous sample it jumps up right. The tester checks if the BER BLER test intersects the early fail or early pass limits. The real time processing can be reduced by the following actions:

BLER₀ (excluding the artificial error at the beginning of the test (Note 1)). is calculated only in case of an error event.

BER₀ (excluding the artificial error at the beginning of the test (Note 1)). is calculated only in case of an error event within a TTI.

So the early fail limit cannot be missed by errorless samples.

The check against the early pass limit may be done by transforming formula (2) in F.6.1.5 such that the tester checks against a Limit-Number-of-samples (NL(ne)) depending on the current number of errors (including the artificial error at the beginning of the test (Note 1)).

Early pass if

$$NL(ne) \geq \frac{qchisq(1 - D, 2 * ne)}{2 * TR * M}$$

TR: test requirement (0.001)

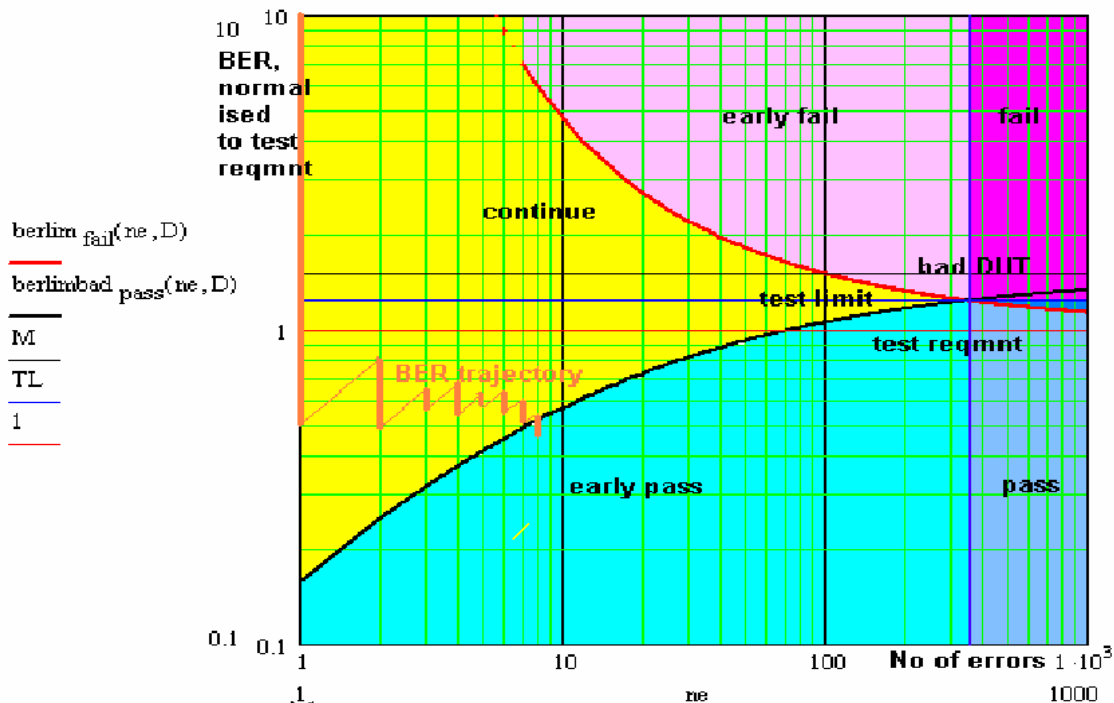

Figure F.6.1.9

Note 1: At the beginning of the test, an artificial error is introduced. This ensures that an ideal DUT meets the valid range of the early pass limit. In addition this ensures that the complementary experiment (F.6.1.4. bullet point (2)) is applicable as well.

For the check against the early fail limit the artificial erroneous sample, introduced at the beginning of the test, is disregarded.

Due to the nature of the test, namely discrete error events, the early fail condition shall not be valid, when fractional errors <1 are used to calculate the early fail limit: Any early fail decision is postponed until number of errors $ne \geq [7]$. In the blocking test any early fail decision is postponed until number of errors $ne \geq [8]$.

Note2: $F=[0.2\%]$ is intended to be used for a test containing a few BER/BLER tests (e.g. receiver sensitivity is repeated 12 times). For a test containing many BER/BLER tests (e.g. blocking test) this value is not appropriate for a single BER/BLER test.

The blocking test contains approx. 12750 single BER tests. A DUT on the limit will fail approx. 25 to 26 times due to statistical reasons (wrong decision probability at the end of the test $F= [0.2\%]$). 24 fails are allowed in the blocking test but they are reserved for spurious responses. This shall be solved by the following rule:

All passes (based on $F=[0.2\%]$) are accepted, including the wrong decisions due to statistical reasons.

An early fail limit based on $F=[0.02\%]$ instead of $[0.2\%]$ is established, that ensures that wrong decisions due to statistical reasons are reduced to 2 to 3.

These asymmetric test conditions ensure that a DUT on the test limit consumes hardly more test time for a blocking test than in the symmetric case and on the other hand discriminates sufficiently between statistical fails and spurious response cases.

F.6.1.10 Dual limit BLER tests

This annex is applicable for subclause 7.8.1 Power control in the downlink constant BLER target and subclause 7.9 Downlink compressed mode. In this tests the BLER shall stay between two limits.

Table F.6.1.10. Parameters for single and dual limit BLER

Parameters for single limit	Parameters for dual limits
Specified BER BLER	Specified BLER * 1.3 (upper test requirement)
	Specified BLER * 0.7 (lower test requirement)
Bad DUT BER BLER	Bad DUT BLER *1.3
	Bad DUT BLER *0.7
Test limit	Upper Test limit
	Lower Test limit
Early fail and	Fail_high
Early pass	Pass_high
	Pass_low
	Fail_low

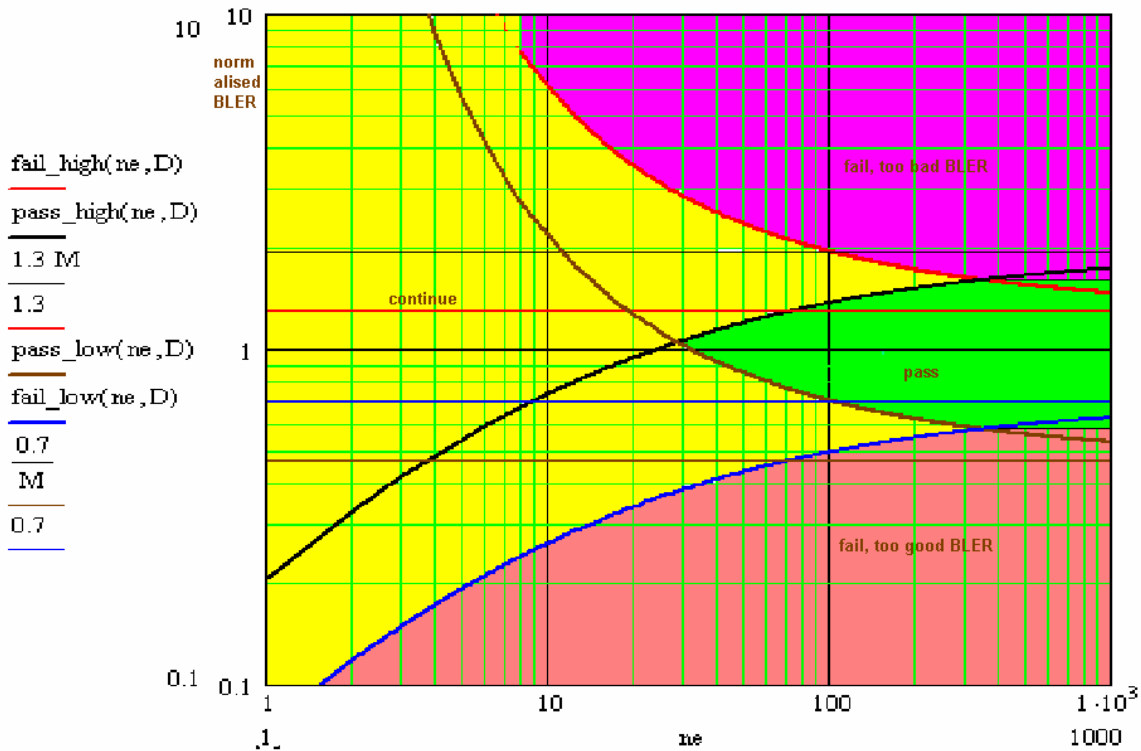

Figure F.6.1.10: Dual limit BLER

F.6.1.10.1 Description of the parameters for dual limit BLER tests

(refer figure F.6.1.10)

The origin

1 (black horizontal line in the centre): this is the normalised origin BLER

The asymptotes

1.3 (red horizontal line): this is the specified upper limit of the range (BLER +30%) (upper test requirement)

0.7 (blue horizontal line): this is the specified lower limit of the range (BLER-30%) (lower test requirement)

1.3*M (black horizontal line): this is M times the specified upper limit of the range (Bad DUT BLER)

0.7/M (brown horizontal line): this is 1/M times the specified lower limit. (Bad DUT BLER)

The pass/fail limits

Fail_high (bold red curve):

Definition: A momentary BLER value above this curve is with high probability above the specified upper limit: BLER +30%.

Verdict: Above: Fail due to bad BLER

Below: continue

It approaches towards 1.3 (red).

Validity range $7 < \text{errors} < 345$.

Formula:

$$\text{fail_high}(\text{ne}, D) := 2 \cdot \frac{\text{ne} \cdot 1.3}{\text{qchisq}(D, 2 \cdot \text{ne})}$$

Fail_low (bold blue curve):

Definition: A momentary BLER value below this curve is with high probability below the specified lower limit: BLER -30%.

Verdict: Above: continue

Below: Fail due to too good BLER

It approaches towards 0.7(blue).

Validity range $1 \leq \text{errors} < 343$.

Formula:

$$\text{fail_low}(\text{ne}, D) := 2 \cdot \frac{\text{ne} \cdot 0.7}{\text{qchisq}(1 - D, 2 \cdot \text{ne})}$$

Pass_high (bold black curve):

Definition: a momentary BLER value on and below this curve is with high probability below M times the specified upper limit.

Verdict: Above: continue

Below: pass for $\text{ne} \geq 29$

continue for $\text{ne} < 29$

It approaches $1.3 \cdot M$ (black).

Validity range $1 \leq \text{errors} < 345$.

Formula:

$$\text{pass_high}(\text{ne}, D) := 2 \cdot \frac{\text{ne}}{\text{qchisq}(1 - D, 2 \cdot \text{ne})} \cdot M \cdot 1.3$$

Pass_low (bold brown curve):

Definition: a momentary BLER value on and above this curve is with high probability above $1/M$ times the specified lower limit of the range.

Verdict: Above: pass for $\text{ne} \geq 29$,

continue for $\text{ne} < 29$

Below: continue

It approaches $0.7/M$ (brown).

Validity range $7 < \text{errors} < 343$.

$$\text{pass_low}(ne, D) := 2 \cdot \frac{ne \cdot \frac{0.7}{M}}{\text{qchisq}(D, 2 \cdot ne)}$$

Legende formulas:

D: wrong decision risk per test step: 0.000085

M: bad DUT factor: 1.5

ne: number of errors

qchisq: inverse cumulative chi square function

Upper test limit (boarder between pink and green) $1.3 * 1.234 = 1.6$

Validity range: $345 \leq \text{errors}$.

Verdict: Above: fail due to bad BLER

Below: pass

Lower test limit (boarder between green and orange) $0.7 / 1.234 = 0.567$

Validity range: $343 \leq \text{errors}$

Verdict: Above: pass

Below: fail due to too good BLER

The intersection co-ordinates:

Fail_high (bold red curve) and Pass_high (bold black curve):

Upper target number of errors (345) and upper test limit: $1.3 * 1.234$

Fail_low (bold blue curve) and Pass_high (bold black curve):

Lower target number of errors (343) and lower test limit: $0.7 / 1.234$

Pass_high (bold black curve) and Pass_low (bold brown curve)

Minimum number of errors (29) and optimum normalised BLER (1.049)

The ranges:

Range(pink): in this range the measurement can be stopped and the DUT is failed due to too high BLER.

Range(orange): in this range the measurement can be stopped and the DUT is failed due to too low BLER.

Range(yellow): in this range the measurement is undecided and must be continued.

Range(green): in this range the measurement can be stopped and the DUT is passed. No final BLER result is achieved.

F.6.1.10.2 Pass fail decision rules

No decision is allowed before the minimum test time (Table F.6.1.6.2) has elapsed

- 1) If minimum Test time < time for target number of error events then the following applies: The required confidence level $1-F$ (= correct decision probability, Table F.6.1.6.2) shall be achieved. This is fulfilled at

fail_high

pass_high

pass_low

fail_low

For every block sum up the number of blocks (n_s) and the number of erroneous blocks (n_e) from the beginning of the test and calculate

$BLER_1$ (including the artificial error at the beginning of the test (Note 1, F.6.1.9)) and

$BLER_0$ (excluding the artificial error at the beginning of the test (Note 1, F.6.1.9)).

If $BLER_0$ is above *fail_high*, fail the test due to too bad BLER

If $BLER_1$ is below *fail_low*, fail the test due to too good BLER

If $BLER_0$ is on or below *fail_high* and if $BLER_1$ is above *pass_high*, continue the test

If $BLER_0$ is below *pass_low* and if $BLER_1$ is above or on *fail_low*, continue the test

If $BLER_1$ is below or on *pass_high* and if $BLER_0$ is on or above *pass_high*, pass the test

- 2) If the minimum test time \geq time for target error events, then the test runs for the minimum test time and the decision is done by comparing the result with the upper and lower test limit.

If $BLER_0$ is above the upper test limit, fail the DUT due to too bad BLER

If $BLER_1$ is below the lower test limit, fail the DUT due to too good BLER

If $BLER_0$ is on or below the upper test limit and if $BLER_1$ is on or above the lower test limit, pass the DUT

F.6.1.10.3 Test conditions for dual limit BLER tests

Table F.6.1.10.3 Test conditions for dual limit BLER tests

Type of test (BLER)	Data rate, Propagation condition	Test requirement (BLER)	Test limit = Test requirement * TL TL	Target number of error events (time)	Minimum number of samples	Prob that a good unit will fail = prob that a bad unit will pass: F[%]	Bad unit factor M
Power control in the downlink, constant BLER target	12.2 kbit/s, 3km/h (case4)	0.01±30%	Upper TL: 1.3*1.234 Lower TL: 0.7/1.234	Upper: 345 (431.25s) Lower 343 (1191s)	8200	0.2	Upper: 1.5 Lower 1/1.5
Downlink compressed mode	12.2kbit/s, 3km/h (case 2)	0.01±30%	Upper TL: 1.3*1.234 Lower TL: 0.7/1.234	Upper: 345 (431.25s) Lower 343 (1191s)	8200	0.2	Upper: 1.5 Lower 1/1.5

F.6.2 Statistical testing of RRM delay performance

F.6.2.1 Test Method

Each test is performed in the following manner:

- a) Setup the required test conditions.
- b) Measure the delay repeated times. Start each repetition after sufficient time, such that each delay test is independent from the previous one. The delay-times, measured, are simplified to:
 - a good delay, if the measured delay is \leq limit.
 - a bad delay, if the measured delay is $>$ limit
- c) Record the number of delays (ns), tested, and the number of bad delays (ne)
- d) Stop the test at an early pass or an early fail event.
- e) Once the test is stopped, decide according to the pass fail decision rules (subclause F.6.2.7)

F.6.2.2 Bad Delay Ratio (ER)

The Bad Delay Ratio (ER) is defined as the ratio of bad delays (ne) to all delays (ns).
(1-ER is the success ratio)

F.6.2.3 Test Criteria

The test shall fulfil the following requirements:

- a) good pass fail decision
 - 1) to keep reasonably low the probability (risk) of passing a bad unit for each individual test;
 - 2) to have high probability of passing a good unit for each individual test;
- b) good balance between test-time and statistical significance
 - 3) to perform measurements with a high degree of statistical significance;
 - 4) to keep the test time as low as possible.

F.6.2.4 Calculation assumptions

F.6.2.4.1 Statistical independence

It is arranged by test conditions, that bad delays are independent statistical events.

F.6.2.4.2 Applied formulas

The specified ER is 10% in most of the cases. This stipulates to use the binomial distribution to describe the RRM delay statistics. With the binomial distribution optimal results can be achieved. However the inverse cumulative operation for the binomial distribution is not supported by standard mathematical tools. The use of the Poisson or Chi Square Distribution requires $ER \rightarrow 0$. Using one of this distributions instead of the binomial distribution gives sub-optimal results in the conservative sense: a pass fail decision is done later than optimal and with a lower wrong decision risk than predefined.

The formulas, applied to describe the RRM delay statistics test, are based on the following experiment:

(1) After having observed a certain number of bad delays (**ne**) the number of all delays (**ns**) are counted to calculate ER. Provisions are made (note 1) such that the complementary experiment is valid as well:

(2) After a certain number of delays (**ns**) the number of bad delays (**ne**), occurred, are counted to calculate ER.

Experiment (1) stipulates to use the Chi Square Distribution with degree of freedom $ne: 2 \cdot dchisq(2 \cdot NE, 2 \cdot ne)$.

Experiment (2) stipulates to use the Poisson Distribution: $dpois(ne, NE)$

(NE: mean value of the distribution)

To determine the early stop conditions, the following inverse cumulative operation is applied:

$0.5 * qchisq(D, 2 \cdot ne)$ for experiment (1) and (2)

D: wrong decision risk per test step

Note: Other inverse cumulative operations are available, however only this is suited for experiment (1) and (2).

F.6.2.4.3 Approximation of the distribution

The test procedure is as follows:

During a running measurement for a UE ns (Number of Delays) and ne (Number of bad delays) are accumulated and from this the preliminary ER is calculated. Then new samples up to the next bad delay are taken. The entire past and the new samples are basis for the next preliminary ER. Depending on the result at every step, the UE can pass, can fail or must continue the test.

As early pass- and early fail-UEs leave the statistical totality under consideration, the experimental conditions are changed every step resulting in a distribution that is truncated more and more towards the end of the entire test. Such a distribution can not any more be handled analytically. The unchanged distribution is used as an approximation to calculate the early fail and early pass bounds.

F.6.2.5 Definition of good pass fail decision.

This is defined by the probability of wrong decision F at the end of the test. The probability of a correct decision is $1 - F$.

The probability (risk) to fail a good DUT shall be $\leq F$ according to the following definition: A DUT is failed, accepting a probability of $\leq F$ that the DUT is still better than the specified bad delay ratio (Test requirement).

The probability (risk) to pass a bad DUT shall be $\leq F$ according to the following definition: A DUT is passed, accepting a probability of $\leq F$ that the DUT is still worse than M times the specified bad delay ratio. ($M \geq 1$ is the bad DUT factor).

This definitions lead to an early pass and an early fail limit:

Early fail: $er \geq erlim_{fail}$

$$er \lim_{fail}(D, ne) = \frac{2 * ne}{qchisq(D, 2 * ne)} \quad (1)$$

For $ne \geq [5]$

Early pass: $er \leq er \lim_{pass}$

$$er \lim_{pass}(D, ne) = \frac{2 * ne * M}{qchisq(1 - D, 2 * ne)} \quad (2)$$

For $ne \geq 1$

With

er (normalized ER): ER according to F.6.2.2 divided by specified ER

D: wrong decision probability for a test step . This is a numerically evaluated fraction of F, the wrong decision probability at the end of the test. see table F.6.2.6.1

ne: Number of bad delays

M: bad DUT factor see table F.6.2.6.1

qchisq: inverse cumulative chi squared distribution

F.6.2.6 Good balance between test-time and statistical significance

Two independent test parameters are introduced into the test and shown in Table F.6.2.6.1. These are the obvious basis of test time and statistical significance. From them four dependent test parameters are derived.

Table F.6.2.6 independent and dependent test parameters

Independent test parameters			Dependent test parameters		
Test Parameter	Value	Reference	Test parameter	Value	Reference
Bad DUT factor M	[1.5]	Table F.6.1.8	Early pass/fail condition	Curves	Subclause F.6.2.5 Figure 6.2.9
Final probability of wrong pass/fail decision F	[5%]	Table F.6.2.8	Target number of bad delays	[154]	Table 6.2.8
			Probability of wrong pass/fail decision per test step D	[0.6 %]	
			Test limit factor TL	[1.236]	Table 6.2.8

F.6.2.7 Pass fail decision rules

The required confidence level $1-F$ (= correct decision probability) shall be achieved. This is fulfilled at an early pass or early fail event. Sum up the number of all delays (ns) and the number of bad delays from the beginning of the test and calculate:

ER_1 (including the artificial error at the beginning of the test (Note 1))and

ER_0 (excluding the artificial error at the beginning of the test (Note 1)).

If ER_0 is on or above the early fail limit, fail the DUT.

If ER_1 is on or below the early pass limit, pass the DUT.

Otherwise continue the test

F.6.2.8 Test conditions for RRM delay tests and Combining of TPC commands test 1

Table F.6.2.8: Test conditions for a single RRM delay tests and Combining of TPC commands test 1

Type of test	Test requirement Delay (s)	Test requirement (ER= 1-success ratio)	Testlimit(ER) = Test requirement (ER)x TL TL	Target number of bad delays	Prob that good unit will fail = Prob that bad unit will pass [%]	Bad unit factor M
8.2.2 Cell reselection	8	0.1	[1.236]	[154]	[5]	[1.5]
8.2.3.1 UTRAN to GSM cell reselection, scenario 1	27.9	0.1	[1.236]	[154]	[5]	[1.5]
8.2.3.2 UTRAN to GSM cell reselection, scenario 2	9.6	0.1	[1.236]	[154]	[5]	[1.5]
8.2.4 FDD/TDD Cell reselection	8	0.1	[1.236]	[154]	[5]	[1.5]
8.3.1 FDD/FDD Soft handover	50+10*KC +100*OC ms	0.1	[1.236]	[154]	[5]	[1.5]
8.3.2 FDD FDD Hard Handover 8.3.2.1 Handover to intra frequency cell	70 ms	0.1	[1.236]	[154]	[5]	[1.5]
8.3.2.2 Handover to interfrequency cell	100ms	0.1	[1.236]	[154]	[5]	[1.5]
7.7.2 Combining of TPC commands Test 1 Note: The theory of statistical testing of RRM delay performance in clause F.6.2 is applied for test case 7.7.2 Combining of TPC commands Test 1. The success ratio for delay is replaced by the success ratio for power control sequence.	Not applicable	0.01	[1.236]	[154]	[5]	[1.5]

F.6.2.9 Practical Use (informative)

See figure F.6.2.9:

The early fail limit represents formula (1) in F.6.2.5. The range of validity is $[n \geq 5]$ to $[n = 154]$

The early pass limit represents the formula (2) in F.6.2.5. The range of validity is $ne=1$ to $[ne=154]$. See note 1. The intersection co-ordinates of both curves are: target number of bad delays $ne = [154]$ and test limit $TL = [1.236]$.

A typical delay test, calculated from the number of samples and errors (F.6.2.2) using experimental method (1) or (2) (see F.6.2.4.2. calculation assumptions) runs along the yellow trajectory. With an good delay the trajectory goes down vertically. With a bad delay it jumps up right. The tester checks if the ER test intersects the early fail or early pass limits.

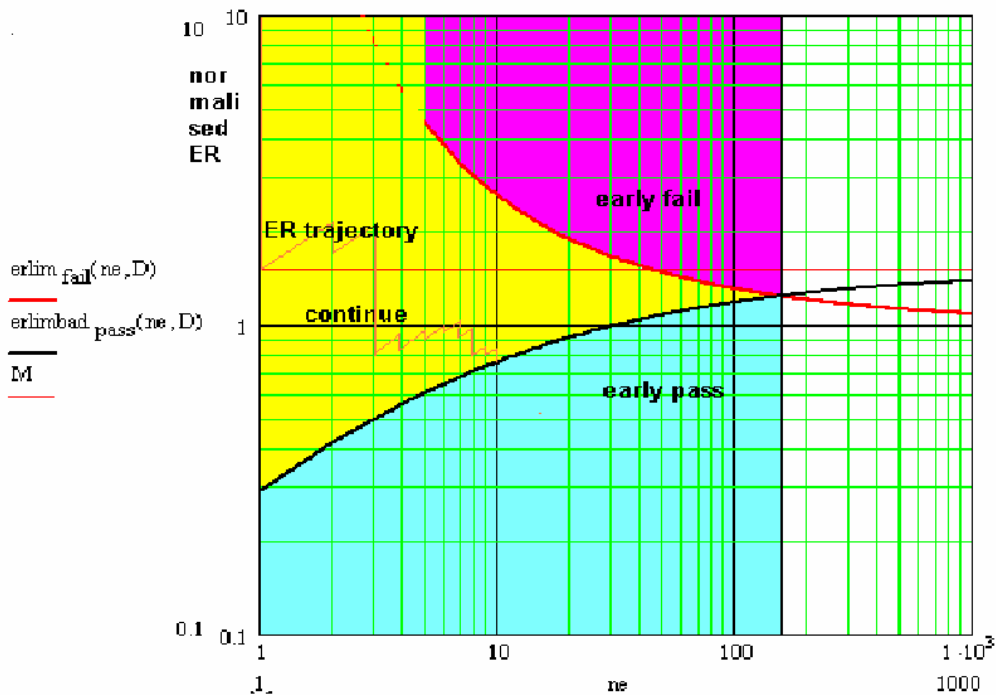

Figure F.6.2.9

Note 1: At the beginning of the test, an artificial bad delay is introduced. This ensures that an ideal DUT meets the valid range of the early pass limit. In addition this ensures that the complementary experiment (F.6.2.4.2. bullet point (2)) is applicable as well. For the check against the early fail limit the artificial bad delay sample, introduced at the beginning of the test, is disregarded.

Due to the nature of the test, namely discrete bad delay events, the early fail condition shall not be valid, when fractional bad delays <1 are used to calculate the early fail limit: Any early fail decision is postponed until number of errors $ne \geq [5]$.

Annex G (normative): Environmental conditions

G.1 General

This normative annex specifies the environmental requirements of the UE. Within these limits the requirements of the present documents shall be fulfilled.

G.2 Environmental requirements

The requirements in this clause apply to all types of UE(s)

G.2.1 Temperature

The UE shall fulfil all the requirements in the full temperature range of:

Table G.2.1.1

+15°C to + 35°C	for normal conditions (with relative humidity of 25 % to 75 %)
-10°C to + 55°C	for extreme conditions (see IEC publications 68-2-1 and 68-2-2)

Outside this temperature range the UE, if powered on, shall not make ineffective use of the radio frequency spectrum. In no case shall the UE exceed the transmitted levels as defined in TS 25.101 [1] for extreme operation.

Some tests in the present document are performed also in extreme temperature conditions. These test conditions are denoted as TL (temperature low, -10°C) and TH (temperature high, +55°C).

G.2.2 Voltage

The UE shall fulfil all the requirements in the full voltage range, i.e. the voltage range between the extreme voltages.

The manufacturer shall declare the lower and higher extreme voltages and the approximate shutdown voltage. For the equipment that can be operated from one or more of the power sources listed below, the lower extreme voltage shall not be higher, and the higher extreme voltage shall not be lower than that specified below.

Table G.2.2.1

Power source	Lower extreme voltage	Higher extreme voltage	Normal conditions voltage
AC mains	0.9 * nominal	1.1 * nominal	nominal
Regulated lead acid battery	0.9 * nominal	1.3 * nominal	1.1 * nominal
Non regulated batteries: - Leclanché / lithium - Mercury/nickel & cadmium	0.85 * nominal 0.90 * nominal	Nominal Nominal	Nominal Nominal

Outside this voltage range the UE if powered on, shall not make ineffective use of the radio frequency spectrum. In no case shall the UE exceed the transmitted levels as defined in TS 25.101 [1] for extreme operation. In particular, the UE shall inhibit all RF transmissions when the power supply voltage is below the manufacturer declared shutdown voltage.

Some tests in the present document are performed also in extreme voltage conditions. These test conditions are denoted as VL (lower extreme voltage) and VH (higher extreme voltage).

G.2.3 Vibration

The UE shall fulfil all the requirements when vibrated at the following frequency/amplitudes:

Table G.2.3.1

Frequency	ASD (Acceleration Spectral Density) random vibration
5 Hz to 20 Hz	0.96 m ² /s ³
20 Hz to 500 Hz	0.96 m ² /s ³ at 20 Hz, thereafter -3 dB / Octave

Outside the specified frequency range the UE, if powered on, shall not make ineffective use of the radio frequency spectrum. In no case shall the UE exceed the transmitted levels as defined in TS 25.101 [1] for extreme operation.

G.2.4 Specified frequency range

The manufacturer shall declare, which of the frequency bands defined in clause 4.2 is supported by the UE.

Some tests in the present document are performed also in low, mid and high range of the operating frequency band of the UE. The UARFCN's to be used for low, mid and high range are defined in TS 34.108 [3] clause 5.1.1.

Annex H (normative): UE Capabilities (FDD)

H.1 Radio Access and RF Baseline Implementation Capabilities:

NOTE 1: This clause shall be aligned with TR 25.926, UE Radio Access Capabilities regarding FDD RF parameters. These RF UE Radio Access capabilities represent options in the UE, that require signalling to the network.

NOTE 2: In addition there are options in the UE that do not require any signalling. They are designated as UE baseline capabilities, according to TR 21.904, Terminal Capability Requirements.

NOTE 3: Table H.1 provides the list of UE radio access capability parameters and possible values.

Table H.1: RF UE Radio Access Capabilities

	UE radio access capability parameter	Value range
FDD RF parameters	UE power class ([23] 25.101 clause 6.2.1)	3, 4
	Tx/Rx frequency separation for frequency band I ([23] 25.101 clause 5.3) Not applicable if UE is not operating in frequency band I	190 MHz, 174.8-205.2 MHz, 134.8-245.2 MHz

Table H.2 provides the UE baseline implementation capabilities.

Table H.2: UE RF Baseline Implementation Capabilities

UE implementation capability	Value range
Radio frequency bands ([23] 25.101 clause 5.2)	I, II, I + II I + III II + III I + II + III

- The special conformance testing functions and the logical test interface as specified in TS 34.109 [4]. This issue is currently under investigation.
- Uplink reference measurement channel 12.2 kbps (FDD), TS 25.101 [1] clause A.2.1
- Downlink reference measurement channel 12.2 kbps (FDD), TS 25.101 [1] clause A.3.1.

H.2 Service Implementation Capabilities:

- Uplink reference measurement channel 64 kbps (FDD), TS 25.101 [1] clause A.2.2
- Uplink reference measurement channel 144 kbps (FDD), TS 25.101 [1] clause A.2.3
- Uplink reference measurement channel 384 kbps (FDD), TS 25.101 [1] clause A.2.4
- Downlink reference measurement channel 64 kbps (FDD), TS 25.101 [1] clause A.3.2.
- Downlink reference measurement channel 144 kbps (FDD), TS 25.101 [1] clause A.3.3.

- Down-link reference measurement channel 384 kbps (FDD), TS 25.101 [1] clause A.3.4.

Annex I (normative): Default Message Contents

This Annex contains the default values of common messages, other than those described in TS 34.108. The messages are primarily concerning the RRM test cases in clause 8 and unless indicated otherwise in specific test cases, shall be transmitted and checked by the system simulator. The necessary messages are listed in alphabetical order.

In this Annex, decimal values are normally used. However, sometimes, a hexadecimal value, indicated by an "H", or a binary value, indicated by a "B" is used.

Contents of MEASUREMENT REPORT message for Intra frequency test cases

Information Element	Value/remark
Message Type	
Integrity check info	The presence of this IE is dependent on IXIT statements in TS 34.123-2. If integrity protection is indicated to be active, this IE shall be present with the values of the sub IEs as stated below. Else, this IE and the sub-IEs shall be absent.
- Message authentication code	This IE is checked to see if it is present. The value is compared against the XMAC-I value computed by SS.
- RRC Message sequence number	This IE is checked to see if it is present. The value is used by SS to compute the XMAC-I value.
Measurement identity	1
Measured Results	
- Intra-frequency measured results list	
- Cell measured results	
- Cell Identity	Not present
- SFN-SFN observed time difference	Checked that this IE is present
- Cell synchronisation information	
- Tm	Checked that this IE is present
- OFF	Checked that this IE is present
- CHOICE mode	FDD
- Primary CPICH info	Checked that this IE is present
- Primary scrambling code	150
- CPICH Ec/N0	Checked that this IE is present
- CPICH RSCP	Checked that this IE is present
- Pathloss	Checked that this IE is present
Measured results on RACH	Checked that this IE is absent
Additional measured results	Checked that this IE is absent
Event results	Checked that this IE is absent

Contents of MEASUREMENT REPORT message for Inter frequency test cases

Information Element	Value/remark
Message Type	
Integrity check info	The presence of this IE is dependent on IXIT statements in TS 34.123-2. If integrity protection is indicated to be active, this IE shall be present with the values of the sub IEs as stated below. Else, this IE and the sub-IEs shall be absent.
- Message authentication code	This IE is checked to see if it is present. The value is compared against the XMAC-I value computed by SS.
- RRC Message sequence number	This IE is checked to see if it is present. The value is used by SS to compute the XMAC-I value.
Measurement identity	1
Measured Results	
- Inter-frequency measured results list	
- UTRA Carrier RSSI	Checked that this IE is present
- Inter-frequency cell measurement results	
- Cell measured results	
- Cell Identity	Not present
- SFN-SFN observed time difference	Checked that this IE is present
- Cell synchronisation information	
-Tm	Checked that this IE is present
- OFF	Checked that this IE is present
- CHOICE mode	FDD
- Primary CPICH info	Checked that this IE is present
- Primary scrambling code	150
- CPICH Ec/N0	Checked that this IE is present
- CPICH RSCP	Checked that this IE is present
- Pathloss	Checked that this IE is present
Measured results on RACH	Checked that this IE is absent
Additional measured results	Checked that this IE is absent
Event results	Checked that this IE is absent

Contents of MEASUREMENT REPORT message for inter – RAT test cases

Information Element	Value/remark
Message Type	
Integrity check info	The presence of this IE is dependent on IXIT statements in TS 34.123-2. If integrity protection is indicated to be active, this IE shall be present with the values of the sub IEs as stated below. Else, this IE and the sub-IEs shall be absent.
- Message authentication code	This IE is checked to see if it is present. The value is compared against the XMAC-I value computed by SS.
- RRC Message sequence number	This IE is checked to see if it is present. The value is used by SS to compute the XMAC-I value.
Measurement identity	1
Measured Results	
- Inter-RAT measured results list	
- CHOICE system	GSM
- Measured GSM cells	Checked that this IE is present
- GSM carrier RSSI	Checked that this IE is present
- Pathloss	Checked that this IE is present
- Observed time difference to GSM cell	Checked that this IE is present
Measured results on RACH	Checked that this IE is absent
Additional measured results	Checked that this IE is absent
Event results	Checked that this IE is absent

Annex J (informative): Information about special regional application of test cases and requirements

This annex provides information about special regional application of the tests specified in the core part of the present document. The special regional application of certain test cases is typically caused by specific local regulation and legalisation.

J.1 Japan

For regulatory testing in Japan shared risk against core specification value with test tolerance of zero may be applied provisionally, until the time the non-zero test tolerances principle used in the present document is reflected in Japanese regulations, The shared risk principle described above will apply to the following requirements:

- 5.9 Spectrum Emission Mask;

NOTE: This information should be reviewed on a regular basis to check its applicability, as changes to regulation allowing usage of the non-zero test tolerances principle are expected.

Annex K (informative): Change history

T Meeting	Doc-1st-Level	CR	Rev	Subject	Cat	Version - Current	Version -New	Doc-2nd-Level
TP-07				Approval of the specification		2.0.0	3.0.0	
				No change: replaces invalid zip file on server		3.0.0	3.0.1	
TP-08	TP-000090	001		Editorial corrections to clauses 2, 3, 4 and 5.1	D	3.0.1	3.1.0	T1-000059
TP-08	TP-000090	002		Modifications to clause 5.4 "Output Power Dynamics in the Uplink"	C	3.0.1	3.1.0	T1-000060
TP-08	TP-000090	003		Out-of-synchronisation handling of the UE	B	3.0.1	3.1.0	T1-000061
TP-08	TP-000090	004		Modifications to clauses 5.8, 5.9, 5.10 and 5.11	D	3.0.1	3.1.0	T1-000062
TP-08	TP-000090	005		Modifications to Chapter 6 "Receiver Characteristics"	F	3.0.1	3.1.0	T1-000063
TP-08	TP-000090	006		Modifications to Annex D, Annex E, Annex G and Annex H	F	3.0.1	3.1.0	T1-000067
TP-08	TP-000090	008		Modifications to clauses 5.5, 5.6 and 5.7	F	3.0.1	3.1.0	T1-000069
TP-08	TP-000090	009		Modifications to Chapter 7 "Performance requirements"	F	3.0.1	3.1.0	T1-000070
TP-08	TP-000090	010		Modifications to test power control in downlink	F	3.0.1	3.1.0	T1-000071
TP-08	TP-000090	011		Modifications to clause 5.13 "Transmit Modulation"	F	3.0.1	3.1.0	T1-000072
TP-08	TP-000090	012		Modifications to test for inner loop power control in the uplink	F	3.0.1	3.1.0	T1-000073
TP-08	TP-000090	013		Revision of Annex B: Global in-channel Tx test	F	3.0.1	3.1.0	T1-000074
TP-08	TP-000090	014		Blind transport format detection	B	3.0.1	3.1.0	T1-000075
TP-08	TP-000090	015		Removal of Annex I "Open Items"	D	3.0.1	3.1.0	T1-000077
TP-08	TP-000090	016		Modifications to Chapter 8 "Requirements for support of RRM"	C	3.0.1	3.1.0	T1-000117
TP-08	TP-000090	017		Modifications to Annex C "Measurement channels"	F	3.0.1	3.1.0	T1-000118
TP-08	TP-000090	018		Idle mode test cases (test of performance requirements)	F	3.0.1	3.1.0	T1-000119
TP-09	TP-000163	019		Editorial corrections for References and Frequency Stability (2, 5.2, 5.3)	F	3.1.0	3.2.0	T1-000131
TP-09	TP-000163	020		Corrections for Output Power Dynamics in the Uplink (5.4)	F	3.1.0	3.2.0	T1-000132
TP-09	TP-000163	021		Transients for uplink inner loop power control (5.4.2.4.2)	F	3.1.0	3.2.0	T1-000133
TP-09	TP-000163	022		Transmit On/Off power (5.5.2.4.2)	F	3.1.0	3.2.0	T1-000134
TP-09	TP-000163	023		Change of TFC (5.6.4.2)	F	3.1.0	3.2.0	T1-000135
TP-09	TP-000163	024		Clarification of the definition on Peak Code Domain Error (5.13.2.1)	F	3.1.0	3.2.0	T1-000139
TP-09	TP-000163	025		UE interfering signal definition (6.3, 6.4, 6.5, 6.7)	F	3.1.0	3.2.0	T1-000140
TP-09	TP-000163	026		Performance requirements (7.1, 7.2, 7.3, 7.4, 7.5)	F	3.1.0	3.2.0	T1-000143
TP-09	TP-000163	027		CR on clause 7.6 and 7.7 in TS34.121 (7.6, 7.7)	F	3.1.0	3.2.0	T1-000144
TP-09	TP-000163	028		Performance requirements (7.9, 7.10, 7.11)	F	3.1.0	3.2.0	T1-000146
TP-09	TP-000163	029		Corrections for Annex D (Annex-D)	F	3.1.0	3.2.0	T1-000147
TP-09	TP-000163	030		Corrections for Annex E (Annex-E)	F	3.1.0	3.2.0	T1-000148
TP-09	TP-000163	031		Corrections for Transmit ON/OFF Power, Change of TFC and Power setting in uplink compressed mode (5.5, 5.6, 5.7)	F	3.1.0	3.2.0	T1-000149
TP-09	TP-000163	032		Corrections for power setting in uplink compressed mode (5.7)	F	3.1.0	3.2.0	T1-000136
TP-09	TP-000163	033		CR for subclause 7.8: Power control in downlink (7.8)	B	3.1.0	3.2.0	T1-000145
TP-09	TP-000163	034		Corrections to clause 5.8, 5.9, 5.10, 5.11 and 5.12	F	3.1.0	3.2.0	T1-000137
TP-09	TP-000163	035		Corrections to EVM and PCDE formulae (B.2.7.1, B.2.7.2)	F	3.1.0	3.2.0	T1-000138
TP-09	TP-000163	036		New initial conditions for Spurious emission test case (6.8.4.1)	F	3.1.0	3.2.0	T1-000141
TP-09	TP-000163	037		C.4.1 UL reference measurement channel for BTFD performance requirement (C.4.1)	F	3.1.0	3.2.0	T1-000142
TP-10	TP-000216	038		Corrections to Chapter 3 "Definitions, symbols, abbreviations and equations"	D	3.2.0	3.3.0	T1-000247
TP-10	TP-000216	039		Vocabulary Corrections	D	3.2.0	3.3.0	T1-000253
TP-10	TP-000216	040		Reference Measurement Channels in Annex C	F	3.2.0	3.3.0	T1-000238
TP-10	TP-000216	041		Inclusion of OCNS definition for performance tests	F	3.2.0	3.3.0	T1-000241
TP-10	TP-000216	042		Handling of measurement uncertainties in UE conformance testing (FDD)	F	3.2.0	3.3.0	T1-000250
TP-10	TP-000216	043		Update of Idle mode test cases	F	3.2.0	3.3.0	T1-000252
TP-10	TP-000216	044		UE emission mask measurement filter definition correction	F	3.2.0	3.3.0	T1-000254
TP-10	TP-000216	045		New structure of TS 34.121	F	3.2.0	3.3.0	T1-000255
TP-10	TP-000216	046		Test for combining TPC commands in soft handover	F	3.2.0	3.3.0	T1-000239
TP-10	TP-000216	047		Corrections to power control tests	F	3.2.0	3.3.0	T1-000240
TP-10	TP-000216	048		Correction to Open Loop Power Control in Uplink	F	3.2.0	3.3.0	T1-000242
TP-10	TP-000216	049		Correction to Transmit ON/OFF Time mask	F	3.2.0	3.3.0	T1-000243r
TP-10	TP-000216	050		Correction to Spurious Emission test	F	3.2.0	3.3.0	T1-000244

T Meeting	Doc-1st-Level	CR	Rev	Subject	Cat	Version - Current	Version -New	Doc-2nd-Level
TP-10	TP-000216	051		Correction of spurious emission measurement procedure	F	3.2.0	3.3.0	T1-000245
TP-10	TP-000216	052		Out-of-synchronization handling of output power	F	3.2.0	3.3.0	T1-000246
TP-10	TP-000216	053		Clarification of test procedure and test requirement for receiver blocking and spurious response.	F	3.2.0	3.3.0	T1-000248
TP-10	TP-000216	054		Subclause 7.8 Power control in downlink	F	3.2.0	3.3.0	T1-000249
TP-10	TP-000216	055		Downlink compressed mode	F	3.2.0	3.3.0	T1-000251
TP-11	TP-010019	056		CR on Test tolerance for 6.5 Blocking Characteristics	F	3.3.0	3.4.0	T1-010020
TP-11	TP-010019	057		CR on Test tolerance for 6.7 Intermodulation Characteristics	F	3.3.0	3.4.0	T1-010025
TP-11	TP-010019	058		CR on Test tolerance for 5.5.1 Test Tolerance for Transmit OFF power	F	3.3.0	3.4.0	T1-010027
TP-11	TP-010019	059		CR on Test tolerance for 6.6 Spurious Response	F	3.3.0	3.4.0	T1-010028
TP-11	TP-010019	060		CR on Test tolerance for 5.11 Test Tolerance for Transmit Spurious emissions	F	3.3.0	3.4.0	T1-010029
TP-11	TP-010019	061		CR on Test tolerance for Annex.F TS34.121	F	3.3.0	3.4.0	T1-010030
TP-11	TP-010019	062		CR on Test tolerance for 5.2 Maximum output power	F	3.3.0	3.4.0	T1-010031
TP-11	TP-010019	063		CR on Test tolerance for 5.4.3 Minimum Output Power	F	3.3.0	3.4.0	T1-010032
TP-11	TP-010019	064		CR on Test tolerance for 5.9 Spectrum Emission Mask	F	3.3.0	3.4.0	T1-010033
TP-11	TP-010019	065		CR on Test tolerance for 5.10 ACLR	F	3.3.0	3.4.0	T1-010034
TP-11	TP-010019	066		CR on Test tolerance for 5.12 Transmit Intermodulation	F	3.3.0	3.4.0	T1-010035
TP-11	TP-010019	067		CR on Test tolerance for 6.2 Reference Sensitivity Level	F	3.3.0	3.4.0	T1-010036
TP-11	TP-010019	068		CR on Test tolerance for 5.3 Frequency Error	F	3.3.0	3.4.0	T1-010037
TP-11	TP-010019	069		CR on Test tolerance for 5.8 Occupied Bandwidth	F	3.3.0	3.4.0	T1-010038
TP-11	TP-010019	070		CR on Test tolerance for 5.13.1 EVM	F	3.3.0	3.4.0	T1-010039
TP-11	TP-010019	071		CR on Test tolerance for 5.13.2 PCDE	F	3.3.0	3.4.0	T1-010040
TP-11	TP-010019	072		CR on Test tolerance for 5.4.4 Out of Synchronisation transmit power	F	3.3.0	3.4.0	T1-010041
TP-11	TP-010019	073		CR on Test tolerance for 6.4 ACS	F	3.3.0	3.4.0	T1-010042
TP-11	TP-010019	074		CR on Test tolerance for 6.8 RX Spurious Emissions	F	3.3.0	3.4.0	T1-010108
TP-11	TP-010019	075		CR on corrections to DL compressed mode	F	3.3.0	3.4.0	T1-010021
TP-11	TP-010019	076		CR on Corrections to DL 384kbps and BTFD measurement channels	F	3.3.0	3.4.0	T1-010022
TP-11	TP-010019	077		CR on Corrections to Maximum output power	F	3.3.0	3.4.0	T1-010023
TP-11	TP-010019	078		CR on RX spurious emissions	F	3.3.0	3.4.0	T1-010024
TP-11	TP-010019	079		CR on Editorial correction to channel number	D	3.3.0	3.4.0	T1-010026
TP-11	TP-010019	080		CR Correction of Annex-E and reference information to Annex E	F	3.3.0	3.4.0	T1-010043
TP-11	TP-010019	081		Editorial corrections	D	3.3.0	3.4.0	T1-010044
TP-11	TP-010076	082	1	Regional requirements on Test Tolerance	F	3.3.0	3.4.0	Presented directly to TP-11
TP-12	TP-010119	083		CR: Addition of Test System uncertainties and Test Tolerances	F	3.4.0	3.5.0	T1-010139
TP-12	TP-010119	084		CR: Measurement accuracy of CPICH RSCP	F	3.4.0	3.5.0	T1-010140
TP-12	TP-010119	085		CR: Measurement accuracy of CPICH Ec/Io	F	3.4.0	3.5.0	T1-010141
TP-12	TP-010119	086		CR: Modifications to the structure of RRM test cases (FDD)	F	3.4.0	3.5.0	T1-010142
TP-12	TP-010119	087		Maintenance CR: Propagation condition 250 km/h	F	3.4.0	3.5.0	T1-010143
TP-12	TP-010119	088		Maintenance CR: Removal of square brackets	F	3.4.0	3.5.0	T1-010144
TP-12	TP-010119	089		Maintenance CR: Tx power for Rx characteristics measurement	F	3.4.0	3.5.0	T1-010145
TP-12	TP-010119	090		Maintenance CR: Correction of Definition of multi-code OCNS signal	F	3.4.0	3.5.0	T1-010146
TP-12	TP-010119	091		Maintenance CR: Conformance requirement to Minimum requirement	D	3.4.0	3.5.0	T1-010147
TP-12	TP-010119	092		Maintenance CR: Test conditions for TS 34.121	F	3.4.0	3.5.0	T1-010148
TP-12	TP-010119	093		Maintenance CR: Editorial correction 34.121	D	3.4.0	3.5.0	T1-010149
TP-12	TP-010119	094		Maintenance CR: closed loop power control close to the limits	C	3.4.0	3.5.0	T1-010150
TP-12	TP-010119	095		Maintenance CR: removal of annex.I	D	3.4.0	3.5.0	T1-010151
TP-12	TP-010119	096		Maintenance CR: correction to annex.E	F	3.4.0	3.5.0	T1-010152
TP-12	TP-010119	097		Maintenance CR: corrections to TS34.121	F	3.4.0	3.5.0	T1-010153
TP-13	TP-010184	098		Annex F Measurement uncertainty	F	3.5.0	3.6.0	T1-010342
TP-13	TP-010184	099		RX Spurious emissions	F	3.5.0	3.6.0	T1-010364
TP-13	TP-010184	100		Structure of RRM test cases	F	3.5.0	3.6.0	T1-010356
TP-13	TP-010184	101		Clause 8.2, Idle mode cell reselection delay tests	F	3.5.0	3.6.0	T1-010361
TP-13	TP-010184	102		Proposal for measuring method of Random Access	F	3.5.0	3.6.0	T1-010362
TP-13	TP-010184	103		Modification to OCNS code channels to allow for 384 kbps allocation	F	3.5.0	3.6.0	T1-010339
TP-13	TP-010184	104		Clarification of AWGN definition	F	3.5.0	3.6.0	T1-010340
TP-13	TP-010184	105		Correction to test for inner loop power control in the uplink	F	3.5.0	3.6.0	T1-010341

T Meeting	Doc-1st-Level	CR	Rev	Subject	Cat	Version - Current	Version -New	Doc-2nd-Level
				(FDD)				
TP-13	TP-010184	106		Core specification change for uplink inner loop power control	F	3.5.0	3.6.0	T1-010355
TP-13	TP-010184	107		Power Control mode in downlink	F	3.5.0	3.6.0	T1-010357
TP-13	TP-010184	108		Correction of frequency range for receiver spurious emission requirements	F	3.5.0	3.6.0	T1-010360
TP-13	TP-010184	109		Test numbering of multi-path fading propagation tests	F	3.5.0	3.6.0	T1-010363
TP-13	TP-010184	110		Measurement of the ON/OFF power during the PRACH preamble	F	3.5.0	3.6.0	T1-010370
TP-14	TP-010259	111		Improvement of test description: CPICH RSCP test case	F	3.6.0	3.7.0	T1-010489
TP-14	TP-010259	112		Improvement of test description: CPICH Ec/Io test case	F	3.6.0	3.7.0	T1-010490
TP-14	TP-010259	113		UTRA Carrier RSSI test case	F	3.6.0	3.7.0	T1-010491
TP-14	TP-010259	114		Corrections and improvements for TS 34.121 subclauses 5, 6 and Annex E	F	3.6.0	3.7.0	T1-010492
TP-14	TP-010259	115		Clarification of test requirements for Transmit ON/OFF time mask	F	3.6.0	3.7.0	T1-010493
TP-14	TP-010259	116		Clarification of procedure for Out-of-synchronisation handling of output power	F	3.6.0	3.7.0	T1-010494
TP-14	TP-010259	117		UE Rx-Tx time difference type 1	F	3.6.0	3.7.0	T1-010495
TP-14	TP-010259	118		UE Transmit Timing	F	3.6.0	3.7.0	T1-010496
TP-14	TP-010259	119		Changes to blocking characteristics and spurious response test cases	F	3.6.0	3.7.0	T1-010497
TP-14	TP-010259	120		Clarification in Spectrum emission mask section	F	3.6.0	3.7.0	T1-010498
TP-14	TP-010259	121		DL Power Control Step Size in performance requirements	F	3.6.0	3.7.0	T1-010499
TP-14	TP-010259	122		DL Compressed mode, correction of pattern	F	3.6.0	3.7.0	T1-010500
TP-14	TP-010259	123		BER/BLER testing based on statistical approach	F	3.6.0	3.7.0	T1-010517
TP-14	TP-010259	124		Deletion of OFF power measurement on "Power setting in uplink compressed mode" Test	F	3.6.0	3.7.0	T1-010520
TP-14	TP-010259	125		Cell reselection delay tests in idle mode	F	3.6.0	3.7.0	T1-010521
TP-14	TP-010259	126		CR for Transmit OFF power measurement	F	3.6.0	3.7.0	T1-010522
TP-15	TP-020039	127		Correction of power terms and definitions	F	3.7.0	3.8.0	T1-020133
TP-15	TP-020039	128		Creation of common default messages for RRM test cases in Annex I	F	3.7.0	3.8.0	T1-020134
TP-15	TP-020039	129		Transmit ON/OFF time mask, Change of TFC and Power setting in uplink compressed mode	F	3.7.0	3.8.0	T1-020135
TP-15	TP-020039	130		Maintenance of Annex B	F	3.7.0	3.8.0	T1-020136
TP-15	TP-020039	131		Correction of minimum test times under fading	F	3.7.0	3.8.0	T1-020137
TP-15	TP-020039	132		Addition of test case description for SFN-CFN observed time difference	F	3.7.0	3.8.0	T1-020138
TP-15	TP-020039	133		Addition of test case description for SFN-SFN observed time difference type 1	F	3.7.0	3.8.0	T1-020139
TP-15	TP-020039	134		Corrections for TS 34.121 subclause 8.7.6	F	3.7.0	3.8.0	T1-020140
TP-15	TP-020039	135		Correction changes in clause 8.7	F	3.7.0	3.8.0	T1-020141
TP-15	TP-020039	136		Update of RRM Cell reselection delay tests in idle mode	F	3.7.0	3.8.0	T1-020142
TP-15	TP-020039	137		Implementation of test tolerances to test cases in subclause 7	F	3.7.0	3.8.0	T1-020143
TP-15	TP-020039	138		RRM AnnexF	F	3.7.0	3.8.0	T1-020144
TP-15	TP-020039	139		Connection Diagrams for RRM tests cell re-selection in idle mode	F	3.7.0	3.8.0	T1-020145
TP-15	TP-020039	140		Statistical testing of RRM delay performance	F	3.7.0	3.8.0	T1-020146
TP-15	TP-020039	141		RRM Hard handover test cases	F	3.7.0	3.8.0	T1-020147
TP-15	TP-020039	142		System Simulator and Test System definition	F	3.7.0	3.8.0	T1-020148
TP-15	TP-020039	143		WCDMA 1800 and 1900 additions	F	3.7.0	3.8.0	T1-020170
TP-15	TP-020039	144		Correction of power spectral density	F	3.7.0	3.8.0	T1-020171
TP-16	TP-020139	145		Spectrum emission mask test case: Change to frequencies to be tested	F	3.8.0	3.9.0	T1-020220
TP-16	TP-020139	146		Power control in downlink, initial convergence	F	3.8.0	3.9.0	T1-020221
TP-16	TP-020139	147		Event triggered reporting in AWGN propagation conditions	F	3.8.0	3.9.0	T1-020222
TP-16	TP-020139	148		Event triggered reporting of multiple neighbours in AWGN propagation conditions	F	3.8.0	3.9.0	T1-020223
TP-16	TP-020139	149		Event triggered reporting of two detectable neighbours in AWGN propagation conditions	F	3.8.0	3.9.0	T1-020224
TP-16	TP-020139	150		Correct reporting of neighbours in fading propagation conditions	F	3.8.0	3.9.0	T1-020226
TP-16	TP-020139	151		Removal of "AFC On" reference from clause 5.3 Frequency Error test	F	3.8.0	3.9.0	T1-020227
TP-16	TP-020139	152		Correct reporting of neighbours in AWGN propagation conditions - inter frequency case	F	3.8.0	3.9.0	T1-020235
TP-16	TP-020139	153		Deletion of test case description 'Correct reporting of neighbours in Fading propagation conditions - Inter	F	3.8.0	3.9.0	T1-020236

T Meeting	Doc-1st-Level	CR	Rev	Subject	Cat	Version - Current	Version -New	Doc-2nd-Level
				frequency case				
TP-16	TP-020139	154		Correction of UE Tx Timing adjustment rate	F	3.8.0	3.9.0	T1-020237
TP-16	TP-020139	155		Correction of Units of side conditions and test parameters	F	3.8.0	3.9.0	T1-020238
TP-16	TP-020139	156		Structure of subclause 8	F	3.8.0	3.9.0	T1-020239
TP-16	TP-020139	157		Inter-system Handover from UTRAN FDD to GSM	F	3.8.0	3.9.0	T1-020240
TP-16	TP-020139	158		UTRAN to GSM Cell Re-Selection: Change of minimum requirements	F	3.8.0	3.9.0	T1-020241
TP-16	TP-020139	159		Cell reselection in idle mode: CR for testcase	F	3.8.0	3.9.0	T1-020242
TP-16	TP-020139	160		Cell reselection in idle mode: CR for annex F.4	F	3.8.0	3.9.0	T1-020243
TP-16	TP-020139	161		UTRAN to GSM cell reselection: CR for testcase	F	3.8.0	3.9.0	T1-020244
TP-16	TP-020139	162		UTRAN to GSM cell reselection: CR for annex F.4	F	3.8.0	3.9.0	T1-020245
TP-16	TP-020139	163		Test parameters of FDD/FDD Hard Handover test case	F	3.8.0	3.9.0	T1-020246
TP-16	TP-020139	164		Addition of details for RRM test cases in 8.3.7.1 and 8.3.7.2 (Cell Re-selection in URA_PCH)	F	3.8.0	3.9.0	T1-020247
TP-16	TP-020139	165		Addition of details for RRM test cases in 8.4.1 (RRC Re-establishment delay)	F	3.8.0	3.9.0	T1-020248
TP-16	TP-020139	166		Addition of details for RRM test case 8.3.1	F	3.8.0	3.9.0	T1-020249
TP-16	TP-020139	167		Addition of details for RRM test case 8.3.5.1	F	3.8.0	3.9.0	T1-020250
TP-16	TP-020139	168		Addition of details for RRM test case 8.3.5.2	F	3.8.0	3.9.0	T1-020251
TP-16	TP-020139	169		UE RX TX time difference: CR for testcase	F	3.8.0	3.9.0	T1-020252
TP-16	TP-020139	170		UE RX TX time difference: CR for annex	F	3.8.0	3.9.0	T1-020253
TP-16	TP-020139	171		Correction for SSDT test parameters and UL DPCCH slot format for performance	F	3.8.0	3.9.0	T1-020265
TP-16	TP-020139	172		Correction of UE FDD EVM definition	F	3.8.0	3.9.0	T1-020266
TP-16	TP-020139	173		Clarification of Meaning of FDR	F	3.8.0	3.9.0	T1-020267
TP-16	TP-020139	174		Modification to the test case for RX spurious emissions in TS34.121	F	3.8.0	3.9.0	T1-020268
TP-16	TP-020139	175		Editorial correction to Open Loop Power Control and Transmit ON/OFF Time mask in TS34.121	F	3.8.0	3.9.0	T1-020422
TP-16	TP-020139	176		Corrections to ACLR in TS34.121	F	3.8.0	3.9.0	T1-020423
TP-17	TP-020185	177	-	Addition of sub clause 8.7.6.2 – UE Rx-Tx time difference	F	3.9.0	3.10.0	T1-020453
TP-17	TP-020185	178	-	Addition of test case Cell reselection in CELL_PCH	F	3.9.0	3.10.0	T1-020454
TP-17	TP-020185	179	-	Addition of test case Transport format combination selection	F	3.9.0	3.10.0	T1-020455
TP-17	TP-020185	180	-	Maintenance of Re-selection and handover test cases	F	3.9.0	3.10.0	T1-020456
TP-17	TP-020185	181	-	Correction of test parameters of Handover to inter-frequency	F	3.9.0	3.10.0	T1-020457
TP-17	TP-020185	182	-	Addition of details for RRM test case 8.7.3C (UE transmitted	F	3.9.0	3.10.0	T1-020458
TP-17	TP-020185	183	-	Corrections to clause 6 and 7 for editorial errors	F	3.9.0	3.10.0	T1-020459
TP-17	TP-020185	184	-	Correction to clause 8.2.2 Cell Re-Selection	F	3.9.0	3.10.0	T1-020460
TP-17	TP-020185	185	-	Correction to clause 8.3.1 FDD/FDD Soft Handover	F	3.9.0	3.10.0	T1-020461
TP-17	TP-020185	187	-	Correction to clause 8.6.1.1 Event triggered reporting in	F	3.9.0	3.10.0	T1-020463
TP-17	TP-020185	188	-	Correction to clause 8.6.1.2 Event triggered reporting of	F	3.9.0	3.10.0	T1-020464
TP-17	TP-020185	189	-	Correction to clause 8.6.1.3 Event triggered reporting of two	F	3.9.0	3.10.0	T1-020465
TP-17	TP-020185	190	-	Correction to clause 8.6.1.4 Correct reporting of neighbours	F	3.9.0	3.10.0	T1-020466
TP-17	TP-020185	191	-	Correction to clause 8.6.2.1 Correct reporting of neighbours	F	3.9.0	3.10.0	T1-020467
TP-17	TP-020185	192	-	Correction to clause 8.7.1 CPICH RSCP	F	3.9.0	3.10.0	T1-020468
TP-17	TP-020185	193	-	Correction to clause 8.7.2 CPICH Ec/lo	F	3.9.0	3.10.0	T1-020469
TP-17	TP-020185	194	-	Correction of test case 'Rx-Tx time difference type 1'.	F	3.9.0	3.10.0	T1-020470
TP-17	TP-020185	195	-	FDD/TDD Handover Test Case	F	3.9.0	3.10.0	T1-020471
TP-17	TP-020185	196	-	Test Requirements for Cell Re-Selection in URA_PCH	F	3.9.0	3.10.0	T1-020474
TP-17	TP-020185	197	-	Correction to clause 8.3.7 Cell Re-selection in URA_PCH	F	3.9.0	3.10.0	T1-020475
TP-17	TP-020185	198	-	Segmented Measurement to be allowed for Inner Loop	F	3.9.0	3.10.0	T1-020476
TP-17	TP-020185	199	-	Correction to clause 8.4.1 RRC Re-establishment delay	F	3.9.0	3.10.0	T1-020477
TP-17	TP-020185	200	-	Correction to clause 8.7.3 UTRA Carrier RSSI	F	3.9.0	3.10.0	T1-020478
TP-17	TP-020185	201	-	Correction to clause 8.7.4 and 8.7.5 SFN-CFN/SFN	F	3.9.0	3.10.0	T1-020479
TP-17	TP-020185	202	-	Addition of a set of Compressed mode reference pattern 2	F	3.9.0	3.10.0	T1-020480
TP-17	TP-020185	203	-	Correction of Compressed Mode Performance Requirement	F	3.9.0	3.10.0	T1-020481
TP-17	TP-020185	204	-	Tx Power level control during Rx testing	F	3.9.0	3.10.0	T1-020482
TP-17	TP-020185	205	-	Deletion of some subclauses from F.6.1 Statistical testing of	F	3.9.0	3.10.0	T1-020483
TP-17	TP-020185	206	-	Correction to clause 8.3.5 Cell Re-selection in CELL_FACH	F	3.9.0	3.10.0	T1-020484
TP-17	TP-020185	207	-	Test Requirements for Cell Re-Selection in CELL-FACH	F	3.9.0	3.10.0	T1-020485
TP-17	TP-020185	208	-	Calculation of Test Requirements for Cell Re-Selection in	F	3.9.0	3.10.0	T1-020486
TP-17	TP-020185	209	-	Clarification of the definition of 90 % success rate	F	3.9.0	3.10.0	T1-020491

T Meeting	Doc-1st-Level	CR	Rev	Subject	Cat	Version - Current	Version -New	Doc-2nd-Level
TP-17	TP-020185	210	-	Update of test requirement derivation of Downlink	F	3.9.0	3.10.0	T1-020492
TP-17	TP-020192	211	-	Correction of regional note in Annex J.1	F	3.9.0	3.10.0	-
TP-18	TP-020294	212	-	Correction of table titles of Demodulation of DCH in closed loop transmit diversity mode test case	F	3.10.0	3.11.0	T1-020631
TP-18	TP-020294	213	-	Maintenance of FDD/TDD Cell Re-selection test case	F	3.10.0	3.11.0	T1-020632
TP-18	TP-020294	214	-	Maintenance of UE Transmit Timing test case	F	3.10.0	3.11.0	T1-020633
TP-18	TP-020294	215	-	Correction of ACLR absolute power limit	F	3.10.0	3.11.0	T1-020634
TP-18	TP-020294	216	-	Correction to clause 8.3.6 Cell Re-selection in CELL_PCH	F	3.10.0	3.11.0	T1-020636
TP-18	TP-020294	217	-	Maintenance of 8.4.2.4 Correct behavior when reaching maximum transmit power	F	3.10.0	3.11.0	T1-020637
TP-18	TP-020294	218	-	Correction of table numbers	F	3.10.0	3.11.0	T1-020639
TP-18	TP-020294	219	-	Correction of message parameter	F	3.10.0	3.11.0	T1-020640
TP-18	TP-020294	220	-	Correction of test parameter in 8.4.2.3 Correct behavior when Time-out	F	3.10.0	3.11.0	T1-020641
TP-18	TP-020294	221	-	Modification of the Random Access Test 8.4.2.1, Correct behaviour when receiving an ACK.	F	3.10.0	3.11.0	T1-020651
TP-18	TP-020294	222	-	Modifications to the test case for Inner Loop Power Control in the Uplink in TS34.121	F	3.10.0	3.11.0	T1-020642
TP-18	TP-020294	223	-	Correction of SCH side conditions and other corrections	F	3.10.0	3.11.0	T1-020750
TP-18	TP-020294	224	-	Corrections of test for power setting in uplink compressed mode	F	3.10.0	3.11.0	T1-020751
TP-18	TP-020294	225	-	Text for annex F.6.2 Statistical testing of RRM delay performance	F	3.10.0	3.11.0	T1-020752
TP-18	TP-020294	226	-	Maintenance of annex F.6.1 Statistical testing of BER BLER performance	F	3.10.0	3.11.0	T1-020753
TP-18	TP-020294	227	-	Dual limit BLER tests	F	3.10.0	3.11.0	T1-020754
TP-18	TP-020294	228	-	Correction of test method: Out-of-synchronisation handling of output power	F	3.10.0	3.11.0	T1-020755
TP-18	TP-020294	229	-	Correction of table and subclause references	F	3.10.0	3.11.0	T1-020756
TP-18	TP-020294	230	-	Revision of table titles in Sec 8. to provide unique and unambiguous descriptions	F	3.10.0	3.11.0	T1-020757
TP-18	TP-020294	231	-	Correction to clause 8.3.2 FDD/FDD Hard Handover	F	3.10.0	3.11.0	T1-020758
TP-18	TP-020294	232	-	Correction to PHYSICAL CHANNEL RECONFIGURATION message that activates compressed mode	F	3.10.0	3.11.0	T1-020759
TP-18	TP-020294	233	-	Introduction of test tolerances in Cell Reselection multi carrier test cases	F	3.10.0	3.11.0	T1-020769
TP-18	TP-020294	234	-	Correction of UL reference measurement channel	F	3.10.0	3.11.0	T1-020889
TP-19	TP-030045	235	-	P-CCPCH RSCP test case for FDD to TDD handover	F	3.11.0	3.12.0	T1-030171
TP-19	TP-030045	236	-	Correct reporting of TDD inter-frequency neighbours in	F	3.11.0	3.12.0	T1-030172
TP-19	TP-030045	237	-	Correction for minimum requirement of UE transmitted	F	3.11.0	3.12.0	T1-030173
TP-19	TP-030045	238	-	Removal of 34.123-1 Annex A reference	F	3.11.0	3.12.0	T1-030174
TP-19	TP-030045	239	-	Correction of UE parameter for Correct behaviour at Time-	F	3.11.0	3.12.0	T1-030175
TP-19	TP-030045	240	-	Correction of Out-of-synchronisation handling of output	F	3.11.0	3.12.0	T1-030178
TP-19	TP-030045	241	-	Removal of uplink dummy DCCH transmission function in	F	3.11.0	3.12.0	T1-030179
TP-19	TP-030045	242	-	Correction for Combining of TPC commands from radio links	F	3.11.0	3.12.0	T1-030186

History

Document history		
V3.0.1	March 2000	Publication
V3.1.0	June 2000	Publication
V3.2.0	September 2000	Publication
V3.3.0	December 2000	Publication
V3.4.0	March 2001	Publication
V3.5.0	June 2001	Publication
V3.6.0	September 2001	Publication
V3.7.0	December 2001	Publication
V3.8.0	March 2002	Publication
V3.9.0	June 2002	Publication
V3.10.0	September 2002	Publication
V3.11.0	December 2002	Publication
V3.12.0	March 2003	Publication