

ETSI TS 134 121-1 V8.0.0 (2007-10)

Technical Specification

**Universal Mobile Telecommunications System (UMTS);
User Equipment (UE) conformance specification;
Radio transmission and reception (FDD);
Part 1: Conformance specification
(3GPP TS 34.121-1 version 8.0.0 Release 8)**



Reference

RTS/TSGR-0534121-1v800

Keywords

UMTS

ETSI

650 Route des Lucioles
F-06921 Sophia Antipolis Cedex - FRANCE

Tel.: +33 4 92 94 42 00 Fax: +33 4 93 65 47 16

Siret N° 348 623 562 00017 - NAF 742 C
Association à but non lucratif enregistrée à la
Sous-Préfecture de Grasse (06) N° 7803/88

Important notice

Individual copies of the present document can be downloaded from:

<http://www.etsi.org>

The present document may be made available in more than one electronic version or in print. In any case of existing or perceived difference in contents between such versions, the reference version is the Portable Document Format (PDF). In case of dispute, the reference shall be the printing on ETSI printers of the PDF version kept on a specific network drive within ETSI Secretariat.

Users of the present document should be aware that the document may be subject to revision or change of status. Information on the current status of this and other ETSI documents is available at

<http://portal.etsi.org/tb/status/status.asp>

If you find errors in the present document, please send your comment to one of the following services:

http://portal.etsi.org/chaicor/ETSI_support.asp

Copyright Notification

No part may be reproduced except as authorized by written permission.
The copyright and the foregoing restriction extend to reproduction in all media.

© European Telecommunications Standards Institute 2007.
All rights reserved.

DECT™, PLUGTESTS™ and UMTS™ are Trade Marks of ETSI registered for the benefit of its Members.
TIPHON™ and the TIPHON logo are Trade Marks currently being registered by ETSI for the benefit of its Members.
3GPP™ is a Trade Mark of ETSI registered for the benefit of its Members and of the 3GPP Organizational Partners.

Intellectual Property Rights

IPRs essential or potentially essential to the present document may have been declared to ETSI. The information pertaining to these essential IPRs, if any, is publicly available for **ETSI members and non-members**, and can be found in ETSI SR 000 314: *"Intellectual Property Rights (IPRs); Essential, or potentially Essential, IPRs notified to ETSI in respect of ETSI standards"*, which is available from the ETSI Secretariat. Latest updates are available on the ETSI Web server (<http://webapp.etsi.org/IPR/home.asp>).

Pursuant to the ETSI IPR Policy, no investigation, including IPR searches, has been carried out by ETSI. No guarantee can be given as to the existence of other IPRs not referenced in ETSI SR 000 314 (or the updates on the ETSI Web server) which are, or may be, or may become, essential to the present document.

Foreword

This Technical Specification (TS) has been produced by ETSI 3rd Generation Partnership Project (3GPP).

The present document may refer to technical specifications or reports using their 3GPP identities, UMTS identities or GSM identities. These should be interpreted as being references to the corresponding ETSI deliverables.

The cross reference between GSM, UMTS, 3GPP and ETSI identities can be found under <http://webapp.etsi.org/key/queryform.asp>.

Contents

Intellectual Property Rights	2
Foreword.....	2
Foreword.....	29
Introduction	29
1 Scope	30
2 References	30
3 Definitions, symbols, abbreviations and equations	31
3.1 Definitions	31
3.2 Symbols.....	32
3.3 Abbreviations	32
3.4 Equations.....	33
4 Frequency bands and channel arrangement.....	34
4.1 General	34
4.2 Frequency bands.....	34
4.3 TX–RX frequency separation.....	35
4.4 Channel arrangement.....	35
4.4.1 Channel spacing.....	35
4.4.2 Channel raster	35
4.4.3 Channel number	35
4.4.4 UARFCN	36
4A Reference Conditions	37
4A.1 Generic setup procedures	37
4A.2 System information	37
4A.3 Message contents.....	38
4A.4 Measurement configurations	38
5 Transmitter Characteristics.....	38
5.1 General	38
5.2 Maximum Output Power	39
5.2.1 Definition and applicability	39
5.2.2 Minimum Requirements	39
5.2.3 Test purpose.....	40
5.2.4 Method of test	40
5.2.4.1 Initial conditions	40
5.2.4.2 Procedure	40
5.2.5 Test requirements.....	40
5.2A Maximum Output Power with HS-DPCCH (Release 5 only)	41
5.2A.1 Definition and applicability	41
5.2A.2 Minimum Requirements	41
5.2A.3 Test purpose.....	42
5.2A.4 Method of test	42
5.2A.4.1 Initial conditions	42
5.2A.4.2 Procedure	42
5.2A.5 Test requirements.....	43
5.2AA Maximum Output Power with HS-DPCCH (Release 6 and later).....	43
5.2AA.1 Definition and applicability	43
5.2AA.2 Minimum Requirements	43
5.2AA.3 Test purpose.....	44
5.2AA.4 Method of test	44
5.2AA.4.1 Initial conditions	44
5.2AA.4.2 Procedure	44
5.2AA.5 Test requirements.....	45

5.2B	Maximum Output Power with HS-DPCCH and E-DCH.....	45
5.2B.1	Definition and applicability	45
5.2B.2	Minimum Requirements	45
5.2B.3	Test purpose.....	46
5.2B.4	Method of test	46
5.2B.4.1	Initial conditions	46
5.2B.4.2	Procedure	48
5.2B.5	Test requirements.....	48
5.2C	UE relative code domain power accuracy	49
5.2C.1	Definition and applicability	49
5.2C.2	Minimum Requirements	49
5.2C.3	Test purpose.....	49
5.2C.4	Method of test	49
5.2C.4.1	Initial conditions	49
5.2C.4.2	Procedure	50
5.2C.5	Test requirements.....	51
5.2D	UE Relative Code Domain Power Accuracy for HS-DPCCH and E-DCH.....	52
5.2D.1	Definition and applicability	52
5.2D.2	Minimum Requirements	52
5.2D.3	Test purpose.....	52
5.2D.4	Method of test	52
5.2D.4.1	Initial conditions	52
5.2D.4.2	Procedure	54
5.2D.5	Test requirements.....	55
5.3	Frequency Error.....	55
5.3.1	Definition and applicability	55
5.3.2	Minimum Requirements	56
5.3.3	Test purpose.....	56
5.3.4	Method of test	56
5.3.5	Test Requirements	56
5.4	Output Power Dynamics in the Uplink.....	56
5.4.1	Open Loop Power Control in the Uplink	56
5.4.1.1	Definition and applicability.....	56
5.4.1.2	Minimum requirements	57
5.4.1.3	Test purpose	57
5.4.1.4	Method of test	57
5.4.1.5	Test requirements.....	58
5.4.2	Inner Loop Power Control in the Uplink	59
5.4.2.1	Definition and applicability.....	59
5.4.2.2	Minimum requirements	59
5.4.2.3	Test purpose	60
5.4.2.4	Method of test	60
5.4.2.5	Test requirements.....	64
5.4.3	Minimum Output Power	66
5.4.3.1	Definition and applicability.....	66
5.4.3.2	Minimum Requirements.....	66
5.4.3.3	Test purpose	66
5.4.3.4	Method of test	66
5.4.3.5	Test requirements.....	67
5.4.4	Out-of-synchronisation handling of output power	67
5.4.4.1	Definition and applicability.....	67
5.4.4.2	Minimum Requirements.....	67
5.4.4.3	Test purpose	69
5.4.4.4	Method of test	69
5.4.4.5	Test requirements.....	70
5.5	Transmit ON/OFF Power	70
5.5.1	Transmit OFF Power	70
5.5.1.1	Definition and applicability.....	70
5.5.1.2	Minimum Requirements.....	70
5.5.1.3	Test purpose	70
5.5.1.4	Method of test	70
5.5.1.5	Test requirements.....	70

5.5.2	Transmit ON/OFF Time mask	71
5.5.2.1	Definition and applicability	71
5.5.2.2	Minimum requirements	71
5.5.2.3	Test purpose	72
5.5.2.4	Method of test	73
5.5.2.5	Test requirements	74
5.6	Change of TFC	74
5.6.1	Definition and applicability	74
5.6.2	Minimum requirements	75
5.6.3	Test purpose	76
5.6.4	Method of test	76
5.6.5	Test requirements	76
5.7	Power setting in uplink compressed mode	77
5.7.1	Definition and applicability	77
5.7.2	Minimum requirements	77
5.7.3	Test purpose	78
5.7.4	Method of test	79
5.7.5	Test requirements	86
5.7A	HS-DPCCH power control	88
5.7A.1	Definition and applicability	88
5.7A.2	Minimum requirement	88
5.7A.3	Test purpose	89
5.7A.4	Method of test	89
5.7A.5	Test requirements	90
5.8	Occupied Bandwidth (OBW)	92
5.8.1	Definition and applicability	92
5.8.2	Minimum Requirements	92
5.8.3	Test purpose	92
5.8.4	Method of test	92
5.8.5	Test Requirements	93
5.9	Spectrum emission mask	93
5.9.1	Definition and applicability	93
5.9.2	Minimum Requirements	93
5.9.3	Test purpose	94
5.9.4	Method of test	94
5.9.4.1	Initial conditions	94
5.9.4.2	Procedure	94
5.9.5	Test requirements	95
5.9A	Spectrum Emission Mask with HS-DPCCH	95
5.9A.1	Definition and applicability	95
5.9A.2	Minimum Requirements	96
5.9A.3	Test purpose	96
5.9A.4	Method of test	96
5.9A.4.1	Initial conditions	96
5.9A.4.2	Procedure	97
5.9A.5	Test requirements	97
5.9B	Spectrum Emission Mask with E-DCH	98
5.9B.1	Definition and applicability	98
5.9B.2	Minimum Requirements	98
5.9B.3	Test purpose	99
5.9B.4	Method of test	99
5.9B.4.1	Initial conditions	99
5.9B.4.2	Procedure	100
5.9B.5	Test requirements	100
5.10	Adjacent Channel Leakage Power Ratio (ACLR)	101
5.10.1	Definition and applicability	101
5.10.2	Minimum Requirements	101
5.10.3	Test purpose	102
5.10.4	Method of test	102
5.10.5	Test requirements	102
5.10A	Adjacent Channel Leakage Power Ratio (ACLR) with HS-DPCCH	102
5.10A.1	Definition and applicability	102

5.10A.2	Minimum Requirements	103
5.10A.3	Test purpose.....	103
5.10A.4	Method of test	103
5.10A.5	Test requirements.....	104
5.10B	Adjacent Channel Leakage Power Ratio (ACLR) with E-DCH.....	104
5.10B.1	Definition and applicability	104
5.10B.2	Minimum Requirements	105
5.10B.3	Test purpose.....	105
5.10B.4	Method of test	105
5.10B.5	Test requirements.....	106
5.11	Spurious Emissions	106
5.11.1	Definition and applicability	106
5.11.2	Minimum Requirements	106
5.11.3	Test purpose.....	109
5.11.4	Method of test	109
5.11.5	Test requirements.....	110
5.12	Transmit Intermodulation.....	112
5.12.1	Definition and applicability	112
5.12.2	Minimum Requirements	113
5.12.3	Test purpose.....	113
5.12.4	Method of test	113
5.12.5	Test requirements.....	113
5.13	Transmit Modulation.....	114
5.13.1	Error Vector Magnitude (EVM)	114
5.13.1.1	Definition and applicability.....	114
5.13.1.2	Minimum Requirements.....	114
5.13.1.3	Test purpose	114
5.13.1.4	Method of test	114
5.13.1.5	Test requirements.....	115
5.13.1A	Error Vector Magnitude (EVM) with HS-DPCCH.....	115
5.13.1A.1	Definition and applicability.....	115
5.13.1A.2	Minimum Requirements.....	115
5.13.1A.3	Test purpose	116
5.13.1A.4	Method of test	116
5.13.1A.5	Test requirements.....	117
5.13.1AA	Error Vector Magnitude (EVM) and phase discontinuity with HS-DPCCH	117
5.13.1AA.1	Definition and applicability.....	117
5.13.1AA.2	Minimum Requirements.....	118
5.13.1AA.3	Test purpose	118
5.13.1AA.4	Method of test	119
5.13.1AA.5	Test requirements.....	120
5.13.2	Peak code domain error	120
5.13.2.1	Definition and applicability.....	120
5.13.2.2	Minimum Requirements.....	121
5.13.2.3	Test purpose	121
5.13.2.4	Method of test	121
5.13.2.5	Test requirements.....	122
5.13.2A	Relative Code Domain Error with HS-DPCCH.....	122
5.13.2A.1	Definition and applicability.....	122
5.13.2A.2	Minimum Requirements.....	122
5.13.2A.3	Test purpose	123
5.13.2A.4	Method of test	123
5.13.2B	Relative Code Domain Error with HS-DPCCH and E-DCH.....	124
5.13.2B.1	Definition and applicability.....	124
5.13.2B.2	Minimum Requirements.....	125
5.13.2B.3	Test purpose	125
5.13.2B.4	Method of test	125
5.13.2B.5	Test requirements.....	127
5.13.3	UE phase discontinuity	129
5.13.3.1	Definition and applicability.....	129
5.13.3.2	Minimum requirements.....	129
5.13.3.3	Test purpose	130

5.13.3.4	Method of test	130
5.13.3.5	Test requirements	131
5.13.4	PRACH preamble quality	132
5.13.4.1	Definition and applicability	132
5.13.4.2	Minimum requirements	132
5.13.4.3	Test purpose	132
5.13.4.4	Method of test	132
5.13.4.5	Test requirements	133
6	Receiver Characteristics	134
6.1	General	134
6.2	Reference Sensitivity Level	134
6.2.1	Definition and applicability	134
6.2.2	Minimum Requirements	135
6.2.3	Test purpose	135
6.2.4	Method of test	135
6.2.5	Test requirements	136
6.3	Maximum Input Level	136
6.3.1	Definition and applicability	136
6.3.2	Minimum requirements	136
6.3.3	Test purpose	136
6.3.4	Method of test	136
6.3.5	Test requirements	137
6.3A	Maximum Input Level for HS-PDSCH Reception (16QAM)	137
6.3A.1	Definition and applicability	137
6.3A.2	Minimum requirements	138
6.3A.3	Test purpose	138
6.3A.4	Method of test	138
6.3A.5	Test requirements	139
6.4	Adjacent Channel Selectivity (ACS) (Rel-99 and Rel-4)	139
6.4.1	Definition and applicability	139
6.4.2	Minimum Requirements	139
6.4.3	Test purpose	140
6.4.4	Method of test	140
6.4.5	Test requirements	140
6.4A	Adjacent Channel Selectivity (ACS) (Rel-5 and later releases)	141
6.4A.1	Definition and applicability	141
6.4A.2	Minimum Requirements	141
6.4A.3	Test purpose	141
6.4A.4	Method of test	141
6.4A.5	Test requirements	142
6.5	Blocking Characteristics	142
6.5.1	Definition and applicability	142
6.5.2	Minimum Requirements	142
6.5.2.1	Minimum Requirements (In-band blocking)	142
6.5.2.2	Minimum requirements (Out of-band blocking)	143
6.5.2.3	Minimum requirements (Narrow band blocking)	145
6.5.3	Test purpose	145
6.5.4	Method of test	145
6.5.5	Test requirements	146
6.6	Spurious Response	149
6.6.1	Definition and applicability	149
6.6.2	Minimum Requirements	149
6.6.3	Test purpose	149
6.6.4	Method of test	149
6.6.5	Test requirements	150
6.7	Intermodulation Characteristics	150
6.7.1	Definition and applicability	150
6.7.2	Minimum Requirements	150
6.7.3	Test purpose	151
6.7.4	Method of test	151
6.7.5	Test requirements	152

6.8	Spurious Emissions	152
6.8.1	Definition and applicability	152
6.8.2	Minimum Requirements	152
6.8.3	Test purpose.....	155
6.8.4	Method of test	155
6.8.5	Test requirements.....	156
7	Performance requirements.....	159
7.1	General	159
7.1.1	Measurement Configurations.....	159
7.1.2	Definition of Additive White Gaussian Noise (AWGN) Interferer	159
7.2	Demodulation in Static Propagation conditions	160
7.2.1	Demodulation of Dedicated Channel (DCH).....	160
7.2.1.1	Definition and applicability.....	160
7.2.1.2	Minimum requirements	160
7.2.1.3	Test purpose	160
7.2.1.4	Method of test	160
7.2.1.5	Test requirements.....	161
7.3	Demodulation of DCH in Multi-path Fading Propagation conditions.....	161
7.3.1	Single Link Performance	161
7.3.1.1	Definition and applicability.....	161
7.3.1.2	Minimum requirements	162
7.3.1.3	Test purpose	164
7.3.1.4	Method of test	164
7.3.1.5	Test requirements.....	164
7.4	Demodulation of DCH in Moving Propagation conditions	167
7.4.1	Single Link Performance	167
7.4.1.1	Definition and applicability.....	167
7.4.1.2	Minimum requirements.....	167
7.4.1.3	Test purpose	167
7.4.1.4	Method of test	168
7.4.1.5	Test requirements.....	168
7.5	Demodulation of DCH in Birth-Death Propagation conditions.....	168
7.5.1	Single Link Performance	168
7.5.1.1	Definition and applicability.....	168
7.5.1.2	Minimum requirements	169
7.5.1.3	Test purpose	169
7.5.1.4	Method of test	169
7.5.1.5	Test requirements.....	169
7.5A	Demodulation of DCH in high speed train condition.....	170
7.5A.1	Single Link Performance	170
7.5A.1.1	Definition and applicability.....	170
7.5A.1.2	Minimum requirement	170
7.5A.1.3	Test purpose	170
7.5A.1.4	Method of test	171
7.5A.1.5	Test requirements.....	171
7.6	Demodulation of DCH in downlink Transmit diversity modes.....	171
7.6.1	Demodulation of DCH in open-loop transmit diversity mode.....	171
7.6.1.1	Definition and applicability.....	171
7.6.1.2	Minimum requirements.....	171
7.6.1.3	Test purpose	172
7.6.1.4	Method of test	172
7.6.1.5	Test Requirements.....	173
7.6.2	Demodulation of DCH in closed loop transmit diversity mode.....	174
7.6.2.1	Definition and applicability.....	174
7.6.2.2	Minimum requirements	174
7.6.2.3	Test purpose	175
7.6.2.4	Method of test	175
7.6.2.5	Test Requirements.....	176
7.6.3	Demodulation of DCH in Site Selection Diversity Transmission Power Control mode.....	177
7.6.3.1	Definition and applicability.....	177
7.6.3.2	Minimum requirements.....	177

7.6.3.3	Test purpose	178
7.6.3.4	Method of test	178
7.6.3.5	Test Requirements.....	181
7.7	Demodulation in Handover conditions.....	182
7.7.1	Demodulation of DCH in Inter-Cell Soft Handover (Release 5 and earlier)	182
7.7.1.1	Definition and applicability.....	182
7.7.1.2	Minimum requirements	182
7.7.1.3	Test purpose	183
7.7.1.4	Method of test	183
7.7.1.5	Test requirements	183
7.7.1A	Demodulation of DCH in Inter-Cell Soft Handover (Release 6 and later)	184
7.7.1A.1	Definition and applicability.....	184
7.7.1A.2	Minimum requirements	184
7.7.1A.3	Test purpose	185
7.7.1A.4	Method of test	185
7.7.1A.5	Test requirements.....	185
7.7.2	Combining of TPC commands from radio links of different radio link sets.....	186
7.7.2.1	Definition and applicability.....	186
7.7.2.2	Minimum requirements	186
7.7.2.3	Test purpose	187
7.7.2.4	Method of test	187
7.7.2.5	Test requirements	188
7.7.3	Combining of reliable TPC commands from radio links of different radio link sets	189
7.7.3.1	Definition and applicability.....	189
7.7.3.2	Minimum requirements	189
7.7.3.3	Test purpose	190
7.7.3.4	Method of test	190
7.7.3.4.1	Test 1 Initial conditions	190
7.7.3.4.2	Test 1 Procedures	190
7.7.3.4.3	Test 2 Initial conditions	190
7.7.3.4.4	Test 2 Procedures	191
7.7.3.5	Test requirements	191
7.8	Power control in downlink	192
7.8.1	Power control in the downlink, constant BLER target	192
7.8.1.1	Definition and applicability.....	192
7.8.1.2	Minimum requirements	193
7.8.1.3	Test purpose	193
7.8.1.4	Method of test	193
7.8.1.5	Test Requirements.....	194
7.8.2	Power control in the downlink, initial convergence.....	194
7.8.2.1	Definition and applicability.....	194
7.8.2.2	Minimum requirements	195
7.8.2.3	Test purpose	195
7.8.2.4	Method of test	195
7.8.2.5	Test Requirements.....	196
7.8.3	Power control in the downlink, wind up effects	197
7.8.3.1	Definition and applicability.....	197
7.8.3.2	Minimum requirements	197
7.8.3.3	Test purpose	198
7.8.3.4	Method of test	198
7.8.3.5	Test Requirements.....	198
7.8.4	Power control in the downlink, different transport formats	199
7.8.4.1	Definition and applicability.....	199
7.8.4.2	Minimum requirements	199
7.8.4.3	Test purpose	200
7.8.4.4	Method of test	200
7.8.4.5	Test Requirements.....	201
7.9	Downlink compressed mode	202
7.9.1	Single link performance	202
7.9.1.1	Definition and applicability.....	202
7.9.1.2	Minimum requirements	202
7.9.1.3	Test purpose	203

7.9.1.4	Method of test	203
7.9.1.5	Test requirements	204
7.10	Blind transport format detection	205
7.10.1	Definition and applicability	205
7.10.2	Minimum requirements	205
7.10.3	Test purpose	206
7.10.4	Method of test	206
7.10.5	Test requirements	206
7.11	Demodulation of Paging Channel (PCH)	207
7.11.1	Definition and applicability	207
7.11.2	Minimum requirements	207
7.11.3	Test purpose	208
7.11.4	Method of test	208
7.11.5	Test requirements	210
7.12	Detection of Acquisition Indicator (AI)	211
7.12.1	Definition and applicability	211
7.12.2	Minimum requirements	211
7.12.3	Test purpose	211
7.12.4	Method of test	211
7.12.5	Test requirements	213
8	Requirements for support of RRM	214
8.1	General	214
8.1.1	Definition of Additive White Gaussian Noise (AWGN) Interferer	214
8.2	Idle Mode Tasks	214
8.2.1	Cell Selection	214
8.2.2	Cell Re-Selection	214
8.2.2.1	Scenario 1: Single carrier case	214
8.2.2.1.1	Definition and applicability	214
8.2.2.1.2	Minimum requirement	214
8.2.2.1.3	Test purpose	215
8.2.2.1.4	Method of test	215
8.2.2.1.5	Test requirements	217
8.2.2.2	Scenario 2: Multi carrier case	218
8.2.2.2.1	Definition and applicability	218
8.2.2.2.2	Minimum requirement	218
8.2.2.2.3	Test purpose	218
8.2.2.2.4	Method of test	218
8.2.2.2.5	Test requirements	221
8.2.3	UTRAN to GSM Cell Re-Selection	223
8.2.3.1	Scenario 1: Both UTRA and GSM level changed	223
8.2.3.1.1	Definition and applicability	223
8.2.3.1.2	Minimum requirement	223
8.2.3.1.3	Test purpose	223
8.2.3.1.4	Method of test	223
8.2.3.1.5	Test requirements	225
8.2.3.2	Scenario 2: Only UTRA level changed	225
8.2.3.2.1	Definition and applicability	225
8.2.3.2.2	Minimum requirement	226
8.2.3.2.3	Test purpose	226
8.2.3.2.4	Method of test	226
8.2.3.2.5	Test requirements	228
8.2.3.3	Scenario 3: HCS with only UTRA level changed	228
8.2.3.3.1	Definition and applicability	228
8.2.3.3.2	Minimum requirement	228
8.2.3.3.3	Test purpose	229
8.2.3.3.4	Method of test	229
8.2.3.3.5	Test requirements	232
8.2.4	FDD/TDD Cell Re-selection	232
8.2.4.1	Definition and applicability	232
8.2.4.1.1	3.84 Mcps TDD Option	233
8.2.4.1.2	1.28 Mcps TDD Option	233

8.2.4.2	Minimum requirement	233
8.2.4.3	Test purpose	233
8.2.4.4	Method of test	233
8.2.4.4.1	Initial conditions	233
8.2.4.4.1.1	3.84 Mcps TDD Option	233
8.2.4.4.1.2	1.28Mcps TDD Option	235
8.2.4.4.2	Procedures	236
8.2.4.5	Test requirements	237
8.3	UTRAN Connected Mode Mobility	237
8.3.1	FDD/FDD Soft Handover	237
8.3.1.1	Definition and applicability	237
8.3.1.2	Minimum requirement	237
8.3.1.3	Test purpose	237
8.3.1.4	Method of test	237
8.3.1.5	Test requirements	244
8.3.2	FDD/FDD Hard Handover	245
8.3.2.1	FDD/FDD Hard Handover to intra-frequency cell	245
8.3.2.1.1	Definition and applicability	245
8.3.2.1.2	Minimum requirement	245
8.3.2.1.3	Test purpose	246
8.3.2.1.4	Method of test	246
8.3.2.1.5	Test requirements	253
8.3.2.2	FDD/FDD Hard Handover to inter-frequency cell	254
8.3.2.2.1	Definition and applicability	254
8.3.2.2.2	Minimum requirement	254
8.3.2.2.3	Test purpose	255
8.3.2.2.4	Method of test	255
8.3.2.2.5	Test requirements	261
8.3.3	FDD/TDD Handover	262
8.3.3.1	Definition and applicability	262
8.3.3.2	Minimum requirement	262
8.3.3.3	Test purpose	262
8.3.3.4	Method of test	262
8.3.3.5	Test requirements	267
8.3.4	Inter-system Handover from UTRAN FDD to GSM	268
8.3.4.1	Definition and applicability	268
8.3.4.2	Minimum requirement	268
8.3.4.3	Test purpose	268
8.3.4.4	Method of test	268
8.3.4.5	Test requirements	276
8.3.5	Cell Re-selection in CELL_FACH	277
8.3.5.1	One frequency present in neighbour list	277
8.3.5.1.1	Definition and applicability	277
8.3.5.1.2	Minimum requirements	277
8.3.5.1.3	Test purpose	277
8.3.5.1.4	Method of test	277
8.3.5.1.5	Test requirements	280
8.3.5.2	Two frequencies present in the neighbour list	280
8.3.5.2.1	Definition and applicability	280
8.3.5.2.2	Minimum requirements	280
8.3.5.2.3	Test purpose	281
8.3.5.2.4	Method of test	281
8.3.5.2.5	Test requirements	284
8.3.5.3	Cell Reselection to GSM	284
8.3.5.3.1	Definition and applicability	284
8.3.5.3.2	Minimum requirements	284
8.3.5.3.3	Test purpose	285
8.3.5.3.4	Method of test	285
8.3.5.3.5	Test requirements	287
8.3.5.4	Cell Reselection during an MBMS session, one frequency present in neighbour list	288
8.3.5.4.1	Definition and applicability	288
8.3.5.4.2	Minimum requirements	288

8.3.5.4.3	Test purpose	289
8.3.5.4.4	Method of test.....	289
8.3.5.4.5	Test requirements	291
8.3.6	Cell Re-selection in CELL_PCH	292
8.3.6.1	One frequency present in the neighbour list.....	292
8.3.6.1.1	Definition and applicability	292
8.3.6.1.2	Minimum requirements	292
8.3.6.1.3	Test purpose	292
8.3.6.1.4	Method of test.....	292
8.3.6.1.5	Test requirements	296
8.3.6.2	Two frequencies present in the neighbour list.....	296
8.3.6.2.1	Definition and applicability	296
8.3.6.2.2	Minimum requirement.....	296
8.3.6.2.3	Test purpose	297
8.3.6.2.4	Method of test.....	297
8.3.6.2.5	Test requirements	301
8.3.6.3	Cell re-selection during an MBMS session, one UTRAN inter-frequency and 2 GSM cells present in the neighbour list	302
8.3.6.3.1	Definition and applicability	302
8.3.6.3.2	Minimum requirement.....	302
8.3.6.3.3	Test purpose	302
8.3.6.3.4	Method of test.....	302
8.3.6.3.5	Test requirements	306
8.3.7	Cell Re-selection in URA_PCH.....	307
8.3.7.1	One frequency present in the neighbour list.....	307
8.3.7.1.1	Definition and applicability	307
8.3.7.1.2	Minimum requirement.....	307
8.3.7.1.3	Test purpose	307
8.3.7.1.4	Method of test.....	307
8.3.7.1.5	Test requirements	311
8.3.7.2	Two frequencies present in the neighbour list.....	311
8.3.7.2.1	Definition and applicability	311
8.3.7.2.2	Minimum requirement.....	311
8.3.7.2.3	Test purpose	312
8.3.7.2.4	Method of test.....	312
8.3.7.2.5	Test requirements	315
8.3.8	Serving HS-DSCH cell change	315
8.3.8.1	Definition and applicability.....	315
8.3.8.2	Minimum requirement	316
8.3.8.3	Test purpose	316
8.3.8.4	Method of test	316
8.3.8.4.1	Initial conditions	319
8.3.8.4.2	Procedure.....	319
8.3.8.5	Test requirements	329
8.4	RRC Connection Control	331
8.4.1	RRC Re-establishment delay	331
8.4.1.1	Test 1.....	331
8.4.1.1.1	Definition and applicability	331
8.4.1.1.2	Minimum requirement.....	331
8.4.1.1.3	Test purpose	332
8.4.1.1.4	Method of test.....	332
8.4.1.1.5	Test requirements	334
8.4.1.2	Test 2.....	334
8.4.1.2.1	Definition and applicability	334
8.4.1.2.2	Minimum requirement.....	334
8.4.1.2.3	Test purpose	335
8.4.1.2.4	Method of test.....	335
8.4.1.2.5	Test requirements	337
8.4.2	Random Access	337
8.4.2.1	Correct behaviour when receiving an ACK (Release 5 and earlier)	337
8.4.2.1.1	Definition and applicability.....	337
8.4.2.1.2	Minimum Requirements.....	337

8.4.2.1.3	Test purpose	337
8.4.2.1.4	Method of test.....	337
8.4.2.1.5	Test requirements	339
8.4.2.1A	Correct behaviour when receiving an ACK (Release 6 and later).....	340
8.4.2.1A.1	Definition and applicability	340
8.4.2.1A.2	Minimum Requirements	340
8.4.2.1A.3	Test purpose	341
8.4.2.1A.4	Method of test.....	341
8.4.2.1A.5	Test requirements	342
8.4.2.2	Correct behaviour when receiving an NACK	343
8.4.2.2.1	Definition and applicability	343
8.4.2.2.2	Minimum Requirements	343
8.4.2.2.3	Test purpose	343
8.4.2.2.4	Method of test.....	344
8.4.2.2.5	Test requirements	344
8.4.2.3	Correct behaviour at Time-out	344
8.4.2.3.1	Definition and applicability	344
8.4.2.3.2	Minimum Requirements	344
8.4.2.3.3	Test purpose	344
8.4.2.3.4	Method of test.....	344
8.4.2.3.5	Test requirements	345
8.4.2.4	Correct behaviour when reaching maximum transmit power	345
8.4.2.4.1	Definition and applicability	345
8.4.2.4.2	Minimum Requirements	345
8.4.2.4.3	Test purpose	345
8.4.2.4.4	Method of test.....	345
8.4.2.4.5	Test requirements	346
8.4.3	Transport format combination selection in UE	346
8.4.3.1	Interactive or Background, PS, UL: 64 kbps.....	346
8.4.3.1.1	Definition and applicability	346
8.4.3.1.2	Minimum requirements	347
8.4.3.1.3	Test purpose	348
8.4.3.1.4	Method of test.....	348
8.4.3.1.5	Test requirements	351
8.4.4	E-TFC restriction in UE.....	351
8.4.4.1	10ms TTI E-DCH E-TFC restriction	351
8.4.4.1.1	Definition and applicability	351
8.4.4.1.2	Minimum requirements	351
8.4.4.1.3	Test Purpose	353
8.4.4.1.4	Method of test.....	354
8.4.4.1.5	Test Requirements	357
8.4.4.2	2ms TTI E-DCH E-TFC restriction	357
8.4.4.2.1	Definition and applicability	357
8.4.4.2.2	Minimum requirements	357
8.4.4.2.3	Test Purpose	360
8.4.4.2.4	Method of test.....	360
8.4.4.2.5	Test Requirements	364
8.5	Timing and Signalling Characteristics	364
8.5.1	UE Transmit Timing	364
8.5.1.1	Definition and applicability.....	364
8.5.1.2	Minimum requirements	365
8.5.1.3	Test purpose	365
8.5.1.4	Method of test	366
8.5.1.5	Test requirements	370
8.6	UE Measurements Procedures.....	372
8.6.1	FDD intra frequency measurements	372
8.6.1.1	Event triggered reporting in AWGN propagation conditions (R99)	372
8.6.1.1.1	Definition and applicability	372
8.6.1.1.2	Minimum requirements	372
8.6.1.1.3	Test purpose	373
8.6.1.1.4	Method of test.....	373
8.6.1.1.5	Test requirements	377

8.6.1.1A	Event triggered reporting in AWGN propagation conditions (Rel-4 and later)	378
8.6.1.1A.1	Definition and applicability	378
8.6.1.1A.2	Minimum requirements	378
8.6.1.1A.3	Test purpose	379
8.6.1.1A.4	Method of test.....	379
8.6.1.1A.5	Test requirements	383
8.6.1.2	Event triggered reporting of multiple neighbours in AWGN propagation condition (R99).....	384
8.6.1.2.1	Definition and applicability	384
8.6.1.2.2	Minimum requirements	384
8.6.1.2.3	Test purpose	384
8.6.1.2.4	Method of test.....	384
8.6.1.2.5	Test requirements	392
8.6.1.2A	Event triggered reporting of multiple neighbours in AWGN propagation condition (Rel-4 and later)	394
8.6.1.2A.1	Definition and applicability	394
8.6.1.2A.2	Minimum requirements	394
8.6.1.2A.3	Test purpose	394
8.6.1.2A.4	Method of test.....	394
8.6.1.2A.5	Test requirements	400
8.6.1.3	Event triggered reporting of two detectable neighbours in AWGN propagation condition (R99).....	401
8.6.1.3.1	Definition and applicability	401
8.6.1.3.2	Minimum requirements	401
8.6.1.3.3	Test purpose	401
8.6.1.3.4	Method of test.....	401
8.6.1.3.5	Test requirements	406
8.6.1.3A	Event triggered reporting of two detectable neighbours in AWGN propagation condition (Rel-4 and later)	408
8.6.1.3A.1	Definition and applicability	408
8.6.1.3A.2	Minimum requirements	408
8.6.1.3A.3	Test purpose	408
8.6.1.3A.4	Method of test.....	408
8.6.1.3A.5	Test requirements	412
8.6.1.4	Void.....	413
8.6.1.4A	Correct reporting of neighbours in fading propagation condition (Rel-4 and later).....	413
8.6.1.4A.1	Definition and applicability	413
8.6.1.4A.2	Minimum requirements	413
8.6.1.4A.3	Test purpose	413
8.6.1.4A.4	Method of test.....	413
8.6.1.4A.5	Test requirements	417
8.6.1.5	Event triggered reporting of multiple neighbour cells in Case 1 fading condition.....	418
8.6.1.5.1	Definition and applicability	418
8.6.1.5.2	Minimum requirements	418
8.6.1.5.3	Test purpose	418
8.6.1.5.4	Method of test.....	418
8.6.1.5.5	Test requirements	422
8.6.1.6	Event triggered reporting of multiple neighbour cells in Case 3 fading condition.....	422
8.6.1.6.1	Definition and applicability	422
8.6.1.6.2	Minimum requirements	422
8.6.1.6.3	Test purpose	423
8.6.1.6.4	Method of test.....	423
8.6.1.6.5	Test requirements	427
8.6.2	FDD inter frequency measurements	428
8.6.2.1	Correct reporting of neighbours in AWGN propagation condition (Release 5 and earlier)	428
8.6.2.1.1	Definition and applicability	428
8.6.2.1.2	Minimum requirements	428
8.6.2.1.3	Test purpose	429
8.6.2.1.4	Method of test.....	429
8.6.2.1.5	Test requirements	437
8.6.2.1A	Correct reporting of neighbours in AWGN propagation condition (Release 6 and later)	438
8.6.2.1A.1	Definition and applicability	438
8.6.2.1A.2	Minimum requirements	438
8.6.2.1A.3	Test purpose	439

8.6.2.1A.4	Method of test.....	439
8.6.2.1A.5	Test requirements	448
8.6.2.2	Correct reporting of neighbours in fading propagation condition (Release 5 only)	449
8.6.2.2.1	Definition and applicability	449
8.6.2.2.2	Minimum requirements	449
8.6.2.2.3	Test purpose	449
8.6.2.2.4	Method of test.....	449
8.6.2.2.4.1	Initial conditions	449
8.6.2.2.4.2	Procedure	450
8.6.2.2.5	Test requirements	455
8.6.2.2A	Correct reporting of neighbours in fading propagation condition (Release 6 and later)	456
8.6.2.2A.1	Definition and applicability	456
8.6.2.2A.2	Minimum requirements	456
8.6.2.2A.3	Test purpose	456
8.6.2.2A.4	Method of test.....	456
8.6.2.2A.4.1	Initial conditions	456
8.6.2.2A.4.2	Procedure	457
8.6.2.2A.5	Test requirements	461
8.6.2.3	Correct reporting of neighbours in fading propagation condition using TGL1=14.....	462
8.6.2.3.1	Definition and applicability	462
8.6.2.3.2	Minimum requirements	462
8.6.2.3.3	Test purpose	462
8.6.2.3.4	Method of test.....	462
8.6.2.3.4.1	Initial conditions	462
8.6.2.3.4.2	Procedure	463
8.6.2.3.5	Test requirements	467
8.6.3	TDD measurements	468
8.6.3.1	Correct reporting of TDD neighbours in AWGN propagation condition.....	468
8.6.3.1.1	Definition and applicability	468
8.6.3.1.2	Minimum requirement	468
8.6.3.1.2.1	3.84Mcps TDD option	468
8.6.3.1.2.2	1.28Mcps TDD option	469
8.6.3.1.3	Test purpose	469
8.6.3.1.4	Method of test.....	469
8.6.3.1.4.1	Initial conditions.....	469
8.6.3.1.4.1.1	3.84Mcps TDD option	469
8.6.3.1.4.1.2	1.28Mcps TDD option	471
8.6.3.1.5	Test requirements	478
8.6.4	GSM measurements	478
8.6.4.1	Correct reporting of GSM neighbours in AWGN propagation condition	478
8.6.4.1.1	Definition and applicability	478
8.6.4.1.2	Minimum requirements	479
8.6.4.1.3	Test purpose	479
8.6.4.1.4	Method of test.....	479
8.6.4.1.4.1	Test 1 initial conditions.....	479
8.6.4.1.4.2	Test 1 Procedure	481
8.6.4.1.4.3	Test 2 initial conditions.....	485
8.6.4.1.4.4	Test 2 Procedure	486
8.6.4.1.5	Test requirements	490
8.6.4.1.5.1	TEST 1 With BSIC verification required.....	490
8.6.4.1.5.2	TEST 2 Without BSIC verification required	490
8.6.5	Combined Interfrequency and GSM measurements	490
8.6.5.1	Correct reporting of neighbours in AWGN propagation condition.....	490
8.6.5.1.1	Definition and applicability	490
8.6.5.1.2	Minimum requirement	490
8.6.5.1.3	Test purpose	491
8.6.5.1.4	Method of test.....	491
8.6.5.1.5	Test requirements	505
8.7	Measurements Performance Requirements	506
8.7.1	CPICH RSCP	506
8.7.1.1	Intra frequency measurements accuracy	506
8.7.1.1.1	Absolute accuracy requirement	506

8.7.1.1.2	Relative accuracy requirement	511
8.7.1.2	Inter frequency measurement accuracy	514
8.7.1.2.1	Relative accuracy requirement	514
8.7.2	CPICH Ec/Io	522
8.7.2.1	Intra frequency measurements accuracy	522
8.7.2.1.1	Absolute accuracy requirement	522
8.7.2.1.2	Relative accuracy requirement	527
8.7.2.2	Inter frequency measurement accuracy	529
8.7.2.2.1	Absolute accuracy requirement	529
8.7.2.2.2	Relative accuracy requirement	529
8.7.3	UTRA Carrier RSSI	538
8.7.3.1	Absolute measurement accuracy requirement	538
8.7.3.1.1	Definition and applicability	538
8.7.3.1.2	Minimum Requirements	538
8.7.3.1.3	Test purpose	538
8.7.3.1.4	Method of test	538
8.7.3.1.5	Test requirements	542
8.7.3.2	Relative measurement accuracy requirement	544
8.7.3.2.1	Definition and applicability	544
8.7.3.2.2	Minimum Requirements	544
8.7.3.2.3	Test purpose	544
8.7.3.2.4	Method of test	544
8.7.3.2.5	Test requirements	549
8.7.3A	GSM Carrier RSSI	551
8.7.3A.1	Definition and applicability	551
8.7.3A.2	Minimum Requirements	551
8.7.3A.3	Test purpose	552
8.7.3A.4	Method of test	552
8.7.3A.4.1	Initial conditions	552
8.7.3A.4.2	Procedure	554
8.7.3A.5	Test requirements	558
8.7.3B	Transport channel BLER	560
8.7.3C	UE transmitted power (R99 and Rel-4 only)	560
8.7.3C.1	Definition and applicability	560
8.7.3C.2	Minimum requirements	560
8.7.3C.3	Test purpose	561
8.7.3C.4	Method of test	561
8.7.3C.4.1	Initial conditions	561
8.7.3C.4.2	Procedure	562
8.7.3C.5	Test requirements	564
8.7.3D	UE transmitted power (Rel-5 and later)	564
8.7.3D.1	Definition and applicability	564
8.7.3D.2	Minimum requirements	564
8.7.3D.3	Test purpose	565
8.7.3D.4	Method of test	565
8.7.3D.4.1	Initial conditions	565
8.7.3D.4.2	Procedure	566
8.7.3D.5	Test requirements	568
8.7.4	SFN-CFN observed time difference	569
8.7.4.1	Intra frequency measurement requirement	569
8.7.4.1.1	Definition and applicability	569
8.7.4.1.2	Minimum requirements	569
8.7.4.1.3	Test Purpose	570
8.7.4.1.4	Method of test	570
8.7.4.1.5	Test requirements	573
8.7.4.2	Inter frequency measurement requirement	574
8.7.4.2.1	Definition and applicability	574
8.7.4.2.2	Minimum requirements	574
8.7.4.2.3	Test purpose	574
8.7.4.2.4	Method of test	574
8.7.4.2.5	Test requirements	580
8.7.5	SFN-SFN observed time difference	581

8.7.5.1	SFN-SFN observed time difference type 1	581
8.7.5.1.1	Definition and applicability	581
8.7.5.1.2	Minimum requirements	581
8.7.5.1.3	Test purpose	581
8.7.5.1.4	Method of test.....	581
8.7.5.1.5	Test requirements	584
8.7.5.2	SFN-SFN observed time difference type 2 without IPDL period active.....	585
8.7.5.2.1	Definition and applicability	585
8.7.5.2.2	Minimum requirements	586
8.7.5.2.3	Test purpose and Environment.....	586
8.7.5.3	SFN-SFN observed time difference type 2 with IPDL period active.....	587
8.7.5.3.1	Definition and applicability	587
8.7.5.3.2	Minimum requirements	587
8.7.5.3.3	Test purpose and Environment.....	588
8.7.6	UE Rx-Tx time difference	589
8.7.6.1	UE Rx-Tx time difference type 1	589
8.7.6.1.1	Definition and applicability	589
8.7.6.1.2	Minimum requirements	589
8.7.6.1.3	Test purpose	589
8.7.6.1.4	Method of test.....	589
8.7.6.1.5	Test requirements	592
8.7.6.2	UE Rx-Tx time difference type 2.....	592
8.7.6.2.1	Definition and applicability	592
8.7.6.2.2	Minimum requirements	593
8.7.6.2.3	Test purpose	593
8.7.7	Observed time difference to GSM cell (R99 and Rel-4 only).....	593
8.7.8	P-CCPCH RSCP.....	593
8.7.8.1	Absolute measurement accuracy	593
8.7.8.1.1	Definition and applicability	593
8.7.8.1.2	Minimum Requirements	594
8.7.8.1.2.1	3.84Mcps TDD option	594
8.7.8.1.2.2	1.28Mcps TDD option	594
8.7.8.1.3	Test purpose	594
8.7.8.1.4	Method of test.....	594
8.7.8.1.4.1	Initial conditions	594
8.7.8.1.4.1.1	3.84Mcps TDD option.....	594
8.7.8.1.4.1.2	1.28Mcps TDD option.....	595
8.7.8.1.4.2	Procedure	596
8.7.8.1.5	Test requirements	599
8.7.9	UE Transmission Power Headroom.....	600
8.7.9.1	Definition and applicability.....	600
8.7.9.2	Minimum Requirements.....	600
8.7.9.3	Test purpose	600
8.7.9.4	Method of test	601
8.7.9.4.1	Initial conditions	601
8.7.9.4.2	Test procedure	602
8.7.9.5	Test requirements.....	602
9	Performance requirements for HSDPA.....	604
9.1	General	604
9.1.1	Definition of Additive White Gaussian Noise (AWGN) Interferer	604
9.2	Demodulation of HS-DSCH (Fixed Reference Channel).....	604
9.2.1	Single Link Performance	606
9.2.1A	Single Link Performance - QPSK/16QAM, Fixed Reference Channel (FRC) H-Set 1/2/3.....	606
9.2.1A.1	Definition and applicability.....	606
9.2.1A.2	Minimum requirements	606
9.2.1A.3	Test purpose	608
9.2.1A.4	Method of test	608
9.2.1A.4.1	Initial conditions	608
9.2.1A.4.2	Procedure.....	608
9.2.1A.5	Test Requirements.....	609
9.2.1B	Single Link Performance - QPSK, Fixed Reference Channel (FRC) H-Set 4/5	610

9.2.1B.1	Definition and applicability.....	610
9.2.1B.2	Minimum requirements.....	610
9.2.1B.3	Test purpose.....	611
9.2.1B.4	Method of test.....	611
9.2.1B.4.1	Initial conditions.....	611
9.2.1B.4.2	Procedure.....	612
9.2.1B.5	Test Requirements.....	612
9.2.1C	Single Link Performance - QPSK/16QAM, Fixed Reference Channel (FRC) H-Set 6/3.....	613
9.2.1C.1	Definition and applicability.....	613
9.2.1C.2	Minimum requirements.....	613
9.2.1C.3	Test purpose.....	615
9.2.1C.4	Method of test.....	615
9.2.1C.4.1	Initial conditions.....	615
9.2.1C.4.2	Procedure.....	616
9.2.1C.5	Test Requirements.....	616
9.2.1D	Single Link Performance - Enhanced Performance Requirements Type 1 - QPSK/16QAM, Fixed Reference Channel (FRC) H-Set 1/2/3.....	617
9.2.1D.1	Definition and applicability.....	617
9.2.1D.2	Minimum requirements.....	618
9.2.1D.3	Test purpose.....	619
9.2.1D.4	Method of test.....	619
9.2.1D.4.1	Initial conditions.....	619
9.2.1D.4.2	Procedure.....	620
9.2.1D.5	Test Requirements.....	620
9.2.1E	Single Link Performance - Enhanced Performance Requirements Type 1- QPSK/16QAM, Fixed Reference Channel (FRC) H-Set 6/3.....	621
9.2.1E.1	Definition and applicability.....	621
9.2.1E.2	Minimum requirements.....	621
9.2.1E.3	Test purpose.....	623
9.2.1E.4	Method of test.....	624
9.2.1E.4.1	Initial conditions.....	624
9.2.1E.4.2	Procedure.....	624
9.2.1E.5	Test Requirements.....	624
9.2.1F	Single Link Performance - Enhanced Performance Requirements Type 2 - QPSK/16QAM, Fixed Reference Channel (FRC) H-Set 6/3.....	626
9.2.1F.1	Definition and applicability.....	626
9.2.1F.2	Minimum requirements.....	626
9.2.1F.3	Test purpose.....	628
9.2.1F.4	Method of test.....	628
9.2.1F.4.1	Initial conditions.....	628
9.2.1F.4.2	Procedure.....	628
9.2.1F.5	Test Requirements.....	628
9.2.1G	Single Link Performance - Enhanced Performance Requirements Type 3 - QPSK/16QAM, Fixed Reference Channel (FRC) H-Set 6/3.....	630
9.2.1G.1	Definition and applicability.....	630
9.2.1G.2	Minimum requirements.....	630
9.2.1G.3	Test purpose.....	632
9.2.1G.4	Method of test.....	632
9.2.1G.4.1	Initial conditions.....	632
9.2.1G.4.2	Procedure.....	633
9.2.1G.5	Test Requirements.....	633
9.2.2	Open Loop Diversity Performance.....	634
9.2.2A	Open Loop Diversity Performance - QPSK/16QAM, Fixed Reference Channel (FRC) H-Set 1/2/3.....	634
9.2.2A.1	Definition and applicability.....	634
9.2.2A.2	Minimum requirements.....	634
9.2.2A.3	Test purpose.....	636
9.2.2A.4	Method of test.....	636
9.2.2A.4.1	Initial conditions.....	636
9.2.2A.4.2	Procedure.....	637
9.2.2A.5	Test Requirements.....	638
9.2.2B	Open Loop Diversity Performance - QPSK, Fixed Reference Channel (FRC) H-Set 4/5.....	639
9.2.2B.1	Definition and applicability.....	639

9.2.2B.2	Minimum requirements	639
9.2.2B.3	Test purpose	640
9.2.2B.4	Method of test	640
9.2.2B.4.1	Initial conditions	640
9.2.2B.4.2	Procedure.....	641
9.2.2B.5	Test Requirements	642
9.2.2C	Open Loop Diversity Performance - Enhanced Performance Requirements Type 1 - QPSK/16QAM, Fixed Reference Channel (FRC) H-Set 1/2/3	642
9.2.2C.1	Definition and applicability.....	642
9.2.2C.2	Minimum requirements	643
9.2.2C.3	Test purpose	644
9.2.2C.4	Method of test	644
9.2.2C.4.1	Initial conditions	644
9.2.2C.4.2	Procedure.....	645
9.2.2C.5	Test Requirements	646
9.2.2D	Open Loop Diversity Performance - Enhanced Performance Requirements Type 2 - QPSK/16QAM, Fixed Reference Channel (FRC) H-Set 3	647
9.2.2D.1	Definition and applicability.....	647
9.2.2D.2	Minimum requirements	647
9.2.2D.3	Test purpose	648
9.2.2D.4	Method of test	648
9.2.2D.4.1	Initial conditions	648
9.2.2D.4.2	Procedure.....	650
9.2.2D.5	Test Requirements	650
9.2.3	Closed Loop Diversity Performance	651
9.2.3A	Closed Loop Diversity Performance - QPSK/16QAM, Fixed Reference Channel (FRC) H-Set 1/2/3	651
9.2.3A.1	Definition and applicability.....	651
9.2.3A.2	Minimum requirements	651
9.2.3A.3	Test purpose	653
9.2.3A.4	Method of test	653
9.2.3A.4.1	Initial conditions	653
9.2.3A.4.2	Procedure.....	654
9.2.3A.5	Test Requirements.....	655
9.2.3B	Closed Loop Diversity Performance - QPSK, Fixed Reference Channel (FRC) H-Set 4/5.....	656
9.2.3B.1	Definition and applicability.....	656
9.2.3B.2	Minimum requirements	656
9.2.3B.3	Test purpose	657
9.2.3B.4	Method of test	657
9.2.3B.4.1	Initial conditions	657
9.2.3B.4.2	Procedure.....	659
9.2.3B.5	Test Requirements.....	659
9.2.3C	Closed Loop Diversity Performance Enhanced Performance Requirements Type 1, QPSK/16QAM, Fixed Reference Channel (FRC) H-Set 1/2/3	660
9.2.3C.1	Definition and applicability.....	660
9.2.3C.2	Minimum requirements	660
9.2.3C.3	Test purpose	662
9.2.3C.4	Method of test	662
9.2.3C.4.1	Initial conditions	662
9.2.3C.4.2	Procedure.....	663
9.2.3C.5	Test Requirements.....	663
9.2.3D	Closed Loop Diversity Performance - Enhanced Performance Requirements Type 2 - QPSK/16QAM, Fixed Reference Channel (FRC) H-Set 6/3	664
9.2.3D.1	Definition and applicability.....	664
9.2.3D.2	Minimum requirements	665
9.2.3D.3	Test purpose	667
9.2.3D.4	Method of test	667
9.2.3D.4.1	Initial conditions	667
9.2.3D.4.2	Procedure.....	669
9.2.3D.5	Test Requirements.....	669
9.3	Reporting of Channel Quality Indicator	671
9.3.1	Single Link Performance - AWGN Propagation Conditions	671
9.3.1.1	Definition and applicability.....	671

9.3.1.2	Minimum requirements	671
9.3.1.3	Test purpose	672
9.3.1.4	Method of test	672
9.3.1.4.1	Initial conditions	672
9.3.1.4.2	Procedure.....	673
9.3.1.5	Test Requirements.....	674
9.3.2	Single Link Performance - Fading Propagation Conditions	674
9.3.2.1	Definition and applicability.....	674
9.3.2.2	Minimum requirements	674
9.3.2.3	Test purpose	675
9.3.2.4	Method of test	675
9.3.2.4.1	Initial conditions.....	675
9.3.2.4.2	Procedure.....	676
9.3.2.5	Test Requirements.....	677
9.3.3	Open Loop Diversity Performance - AWGN Propagation Conditions	677
9.3.3.1	Definition and applicability	677
9.3.3.2	Minimum requirements	677
9.3.3.3	Test purpose	678
9.3.3.4	Method of test	678
9.3.3.4.1	Initial conditions	678
9.3.3.4.2	Procedure.....	679
9.3.3.5	Test Requirements.....	681
9.3.4	Open Loop Diversity Performance - Fading Propagation Conditions	681
9.3.4.1	Definition and applicability.....	681
9.3.4.2	Minimum requirements	681
9.3.4.3	Test purpose	682
9.3.4.4	Method of test	682
9.3.4.4.1	Initial conditions.....	682
9.3.4.4.2	Procedure.....	683
9.3.4.5	Test Requirements.....	685
9.3.5	Closed Loop Diversity Performance - AWGN Propagation Conditions	685
9.3.5.1	Definition and applicability	685
9.3.5.2	Minimum requirements	685
9.3.5.3	Test purpose	686
9.3.5.4	Method of test	686
9.3.5.4.1	Initial conditions.....	686
9.3.5.4.2	Procedure.....	687
9.3.5.5	Test Requirements.....	689
9.3.6	Closed Loop Diversity Performance - Fading Propagation Conditions	689
9.3.6.1	Definition and applicability.....	689
9.3.6.2	Minimum requirements	689
9.3.6.3	Test purpose	690
9.3.6.4	Method of test	690
9.3.6.4.1	Initial conditions	690
9.3.6.4.2	Procedure.....	691
9.3.6.5	Test Requirements.....	693
9.4	HS-SCCH Detection Performance	693
9.4.1	Single Link Performance	693
9.4.1.1	Definition and applicability.....	693
9.4.1.2	Minimum requirements.....	693
9.4.1.3	Test purpose	694
9.4.1.4	Method of test	694
9.4.1.4.1	Initial conditions	694
9.4.1.4.2	Procedure.....	694
9.4.1.5	Test Requirements.....	695
9.4.1A	Single Link Performance – Enhanced Performance Requirements Type 1	695
9.4.1A.1	Definition and applicability.....	695
9.4.1A.2	Minimum requirements	696
9.4.1A.3	Test purpose	696
9.4.1A.4	Method of test	696
9.4.1A.4.1	Initial conditions	696
9.4.1A.4.2	Procedure.....	696

9.4.1A.5	Test Requirements.....	697
9.4.2	Open Loop Diversity Performance	698
9.4.2.1	Definition and applicability.....	698
9.4.2.2	Minimum requirements	698
9.4.2.3	Test purpose	698
9.4.2.4	Method of test	698
9.4.2.4.1	Initial conditions	698
9.4.2.4.2	Procedure.....	699
9.4.2.5	Test Requirements.....	700
9.4.2A	Open Loop Diversity Performance - Enhanced Performance Requirements Type 1	700
9.4.2A.1	Definition and applicability.....	700
9.4.2A.2	Minimum requirements	700
9.4.2A.3	Test purpose	701
9.4.2A.4	Method of test	701
9.4.2A.4.1	Initial conditions	701
9.4.2A.4.2	Procedure.....	701
9.4.2A.5	Test Requirements.....	702
10	Performance requirement (E-DCH)	704
10.1	General	704
10.2	Detection of E-DCH HARQ ACK Indicator Channel (E-HICH).....	704
10.2.1	Single link performance	704
10.2.1.1	Single link performance (10ms TTI).....	704
10.2.1.1.1	Definition and applicability	704
10.2.1.1.2	Minimum requirement.....	704
10.2.1.1.3	Test purpose	705
10.2.1.1.4	Method of test.....	705
10.2.1.1.4.1	Initial conditions	705
10.2.1.1.4.2	Procedure	706
10.2.1.1.5.	Test requirements	707
10.2.1.1A	Single link performance (10ms TTI, Type 1).....	707
10.2.1.1A.1	Definition and applicability	707
10.2.1.1A.2	Minimum requirement.....	707
10.2.1.1A.3	Test purpose	708
10.2.1.1A.4	Method of test.....	708
10.2.1.1A.4.1	Initial conditions	708
10.2.1.1A.4.2	Procedure	708
10.2.1.1A.5.	Test requirements	709
10.2.1.2	Single link performance (2ms TTI).....	709
10.2.1.2.1	Definition and applicability	709
10.2.1.2.2	Minimum requirement.....	709
10.2.1.2.3	Test purpose	710
10.2.1.2.4	Method of test.....	710
10.2.1.2.4.1	Initial conditions	710
10.2.1.2.4.2	Procedure	711
10.2.1.2.5.	Test requirements	712
10.2.1.2A	Single link performance (2ms TTI, Type 1).....	712
10.2.1.2A.1	Definition and applicability	712
10.2.1.2A.2	Minimum requirement.....	712
10.2.1.2A.3	Test purpose	713
10.2.1.2A.4	Method of test.....	713
10.2.1.2A.4.1	Initial conditions	713
10.2.1.2A.4.2	Procedure	713
10.2.1.2A.5.	Test requirements	714
10.2.2	Detection in Inter-Cell Handover conditions	714
10.2.2.1	RLS not containing the Serving E-DCH cell	714
10.2.2.1.1	RLS not containing the Serving E-DCH cell (10ms TTI)	714
10.2.2.1.1.1	Definition and applicability	714
10.2.2.1.1.2	Minimum requirement	715
10.2.2.1.1.3	Test Purpose.....	715
10.2.2.1.1.4	Method of test	715
10.2.2.1.1.5	Test Requirements	718

10.2.2.1.1A	RLS not containing the Serving E-DCH cell (10ms TTI, Type 1)	719
10.2.2.1.1A.1	Definition and applicability	719
10.2.2.1.1A.2	Minimum requirement	719
10.2.2.1.1A.3	Test Purpose.....	720
10.2.2.1.1A.4	Method of test	720
10.2.2.1.1A.5	Test Requirements	722
10.2.2.1.2	RLS not containing the Serving E-DCH cell (2ms TTI)	723
10.2.2.1.2.1	Definition and applicability	723
10.2.2.1.2.2	Minimum requirement	723
10.2.2.1.2.3	Test Purpose.....	724
10.2.2.1.2.4	Method of test	724
10.2.2.1.2.4.1	Initial conditions.....	724
10.2.2.1.2.4.2	Procedure.....	725
10.2.2.1.2.5	Test Requirements	727
10.2.2.1.2A	RLS not containing the Serving E-DCH cell (2ms TTI, Type 1)	728
10.2.2.1.2A.1	Definition and applicability	728
10.2.2.1.2A.2	Minimum requirement	729
10.2.2.1.2A.3	Test Purpose.....	729
10.2.2.1.2A.4	Method of test	729
10.2.2.1.2A.4.1	Initial conditions.....	729
10.2.2.1.2A.4.2	Procedure.....	730
10.2.2.1.2A.5	Test Requirements	731
10.2.2.2	RLS containing the Serving E-DCH cell	732
10.2.2.2.1	RLS containing the Serving E-DCH cell (10ms TTI)	732
10.2.2.2.1.1	Definition and applicability	732
10.2.2.2.1.2	Minimum requirement	732
10.2.2.2.1.3	Test purpose.....	733
10.2.2.2.1.4	Method of test	733
10.2.2.2.1.4.1	Initial conditions.....	733
10.2.2.2.1.4.2	Procedure.....	734
10.2.2.2.1.5	Test requirements.....	736
10.2.2.2.1A	RLS containing the Serving E-DCH cell (10ms TTI, Type 1)	737
10.2.2.2.1A.1	Definition and applicability	737
10.2.2.2.1A.2	Minimum requirement	738
10.2.2.2.1A.3	Test purpose.....	738
10.2.2.2.1A.4	Method of test	738
10.2.2.2.1A.4.1	Initial conditions.....	738
10.2.2.2.1A.4.2	Procedure.....	739
10.2.2.2.1A.5	Test requirements.....	740
10.2.2.2.2	RLS containing the Serving E-DCH cell (2ms TTI)	741
10.2.2.2.2.1	Definition and applicability	741
10.2.2.2.2.2	Minimum requirement	741
10.2.2.2.2.3	Test purpose.....	742
10.2.2.2.2.4	Method of test	742
10.2.2.2.2.4.1	Initial conditions.....	742
10.2.2.2.2.4.2	Procedure.....	743
10.2.2.2.2.5	Test requirements.....	745
10.2.2.2.2A	RLS containing the Serving E-DCH cell (2ms TTI, Type 1)	746
10.2.2.2.2A.1	Definition and applicability	746
10.2.2.2.2A.2	Minimum requirement	746
10.2.2.2.2A.3	Test purpose.....	747
10.2.2.2.2A.4	Method of test	747
10.2.2.2.2A.4.1	Initial conditions.....	747
10.2.2.2.2A.4.2	Procedure.....	748
10.2.2.2.2A.5	Test requirements.....	749
10.3	Detection of E-DCH Relative Grant Channel (E-RGCH)	750
10.3.1	Single link performance	750
10.3.1.1	Single link performance (10ms TTI).....	750
10.3.1.1.1	Definition and applicability	750
10.3.1.1.2	Minimum requirement	750
10.3.1.1.3	Test purpose	751
10.3.1.1.4	Method of test.....	751

10.3.1.1.4.1	Initial conditions	751
10.3.1.1.4.2	Procedure	752
10.3.1.1.5	Test requirements	753
10.3.1.1A	Single link performance (10ms TTI, Type 1).....	754
10.3.1.1A.1	Definition and applicability	754
10.3.1.1A.2	Minimum requirement.....	754
10.3.1.1A.3	Test purpose	754
10.3.1.1A.4	Method of test.....	755
10.3.1.1A.4.1	Initial conditions	755
10.3.1.1A.4.2	Procedure	755
10.3.1.1A.5	Test requirements	756
10.3.1.2	Single link performance (2ms TTI).....	757
10.3.1.2.1	Definition and applicability	757
10.3.1.2.2	Minimum requirement	757
10.3.1.2.3	Test purpose	758
10.3.1.2.4	Method of test.....	758
10.3.1.2.4.1	Initial conditions	758
10.3.1.2.4.2	Procedure	758
10.3.1.2.5	Test requirements	760
10.3.1.2A	Single link performance (2ms TTI, Type 1).....	761
10.3.1.2A.1	Definition and applicability	761
10.3.1.2A.2	Minimum requirement	761
10.3.1.2A.3	Test purpose	761
10.3.1.2A.4	Method of test.....	761
10.3.1.2A.4.1	Initial conditions	761
10.3.1.2A.4.2	Procedure	762
10.3.1.2A.5	Test requirements	763
10.3.2	Detection in Inter-Cell Handover conditions	763
10.3.2.1	Definition and applicability.....	763
10.3.2.2	Minimum requirement for Non-serving E-DCH RL.....	764
10.3.2.3	Test Purpose	764
10.3.2.4	Method of test	764
10.3.2.4.1	Initial conditions	764
10.3.2.4.2	Procedure.....	765
10.3.2.5	Test Requirements.....	768
10.3.2A	Detection in Inter-Cell Handover conditions (Type 1)	769
10.3.2A.1	Definition and applicability.....	769
10.3.2A.2	Minimum requirement for Non-serving E-DCH RL.....	770
10.3.2A.3	Test Purpose	770
10.3.2A.4	Method of test	770
10.3.2A.4.1	Initial conditions	770
10.3.2A.4.2	Procedure.....	771
10.3.2A.5	Test Requirements.....	773
10.4	Demodulation of E-DCH Absolute Grant Channel (E-AGCH)	774
10.4.1	Single link performance	774
10.4.1.1	Definition and applicability.....	774
10.4.1.2	Minimum requirement	774
10.4.1.3	Test Purpose	775
10.4.1.4	Method of test	775
10.4.1.4.1	Initial conditions	775
10.4.1.4.2	Procedure.....	775
10.4.1.5	Test Requirements.....	776
10.4.1A	Single link performance (Type 1).....	777
10.4.1A.1	Definition and applicability.....	777
10.4.1A.2	Minimum requirement	777
10.4.1A.3	Test Purpose	777
10.4.1A.4	Method of test	777
10.4.1A.4.1	Initial conditions	777
10.4.1A.4.2	Procedure.....	778
10.4.1A.5	Test Requirements.....	778
11	Performance requirement (MBMS).....	779

11.1	General	779
11.2	Demodulation of MTCH	779
11.2.1	Definition and applicability	779
11.2.2	Minimum requirement	779
11.2.3	Test Purpose.....	780
11.2.4	Method of test	780
11.2.4.1	Initial conditions	780
11.2.4.2	Procedure	780
11.2.5	Test Requirements	781
11.2A	Demodulation of MTCH - Enhanced Performance Requirements Type 1	781
11.2A.1	Definition and applicability	781
11.2A.2	Minimum requirement	782
11.2A.3	Test Purpose.....	782
11.2A.4	Method of test	782
11.2A.4.1	Initial conditions	782
11.2A.4.2	Procedure	783
11.2A.5	Test Requirements	783
11.3	Demodulation of MTCH and cell identification.....	784
11.3.1	Definition and applicability	784
11.3.2	Minimum requirements.....	784
11.3.3	Test purpose.....	785
11.3.4	Method of test.....	785
11.3.5	Test requirements.....	786
Annex A (informative): Connection Diagrams		787
Annex B (normative): Global In-Channel TX-Test		801
B.1	General	801
B.2	Definition of the process	801
B.2.1	Basic principle.....	801
B.2.2	Output signal of the TX under test	801
B.2.3	Reference signal	801
B.2.4	void.....	801
B.2.5	Classification of measurement results	801
B.2.6	Process definition to achieve results of type "deviation".....	802
B.2.6.1	Decision Point Power.....	802
B.2.6.2	Code-Domain Power.....	803
B.2.7	Process definition to achieve results of type "residual".....	803
B.2.7.1	Error Vector Magnitude (EVM)	803
B.2.7.2	Peak Code Domain Error (PCDE)	804
B.3	Notes.....	804
Annex C (normative): Measurement channels.....		807
C.1	General	807
C.2	UL reference measurement channel	807
C.2.1	UL reference measurement channel (12,2 kbps).....	807
C.2.2	UL reference measurement channel (64 kbps)	809
C.2.3	UL reference measurement channel (144 kbps)	811
C.2.4	UL reference measurement channel (384 kbps)	813
C.2.5	UL reference measurement channel (768 kbps)	815
C.3	DL reference measurement channel	817
C.3.1	DL reference measurement channel (12.2 kbps).....	817
C.3.1A	DL reference measurement channel (0 kbps and 12.2 kbps).....	818
C.3.2	DL reference measurement channel (64 kbps).....	820
C.3.3	DL reference measurement channel (144 kbps).....	822
C.3.4	DL reference measurement channel (384 kbps).....	824
C.4	Reference measurement channel for BTFD performance requirements	826
C.4.1	UL reference measurement channel for BTFD performance requirements.....	826

C.4.2	DL reference measurement channel for BTFD performance requirements.....	829
C.5	DL reference compressed mode parameters.....	832
C.6	Auxiliary measurement channels	834
C.6.1	Introduction	834
C.6.2	Channel combinations for BLER measurements.....	835
C.6.3	UL auxiliary reference measurement channel (TM, 12.2 kbps, no CRC)	836
C.6.3A	UL auxiliary reference measurement channel (TM, 0 kbps and 12.2 kbps, no CRC)	836
C.6.4	Void.....	837
C.6.5	Void.....	837
C.6.6	Void.....	837
C.6.7	UL AUXMC AM 12.2 kbps.....	838
C.7	DL reference parameters for PCH tests.....	838
C.8	DL reference channel parameters for HSDPA tests.....	839
C.8.1	Fixed Reference Channel (FRC)	839
C.8.1.1	Fixed Reference Channel Definition H-Set 1	839
C.8.1.2	Fixed Reference Channel Definition H-Set 2	840
C.8.1.3	Fixed Reference Channel Definition H-Set 3	841
C.8.1.4	Fixed Reference Channel Definition H-Set 4	842
C.8.1.5	Fixed Reference Channel Definition H-Set 5	843
C.8.1.6	Fixed Reference Channel Definition H-Set 6	843
C.9	Downlink reference channel dummy DCCH transmission on DCH.....	844
C.9A	MAC header transmission on HS-DSCH.....	844
C.10	UL reference channel parameters for HSDPA tests.....	845
C.10.1	UL reference measurement channel for HSDPA tests.....	845
C.11	Reference channel parameters for E-DCH tests.....	846
C.11.1	UL reference measurement channel for E-DCH tests	846
C.11.2	DL reference measurement channel for E-DCH tests	846
C.11.3	RLC SDU size for E-DCH tests	846
C.12	DL reference parameters for MBMS tests.....	847
C.12.1	MTCH	847
C.12.2	Combined MTCH demodulation and cell identification	848
Annex D (normative): Propagation Conditions		849
D.1	General	849
D.1.1	Definition of Additive White Gaussian Noise (AWGN) Interferer.....	849
D.2	Propagation Conditions	849
D.2.1	Static propagation condition.....	849
D.2.2	Multi-path fading propagation conditions	849
D.2.3	Moving propagation conditions.....	851
D.2.4	Birth-Death propagation conditions	851
D.2.4A	High speed train conditions	852
D.2.5	Conditions for HSDPA enhanced performance requirements type 1 with UE receiver diversity	853
D.2.6	Conditions for HSDPA enhanced performance requirements type 3 with UE receiver diversity	853
D.2.7	Conditions for open and closed loop diversity performance	853
Annex E (normative): Downlink Physical Channels.....		854
E.1	General	854
E.2	Connection Set-up for non-HSDPA test cases	854
E.2.1	Measurement without dedicated connection	854
E.3	During connection for non-HSDPA test cases	854
E.3.1	Measurement of Tx Characteristics.....	855
E.3.2	Measurement of Rx Characteristics.....	855
E.3.3	Measurement of Performance requirements.....	855

E.3.4	Connection with open-loop transmit diversity mode.....	857
E.3.5	Connection with closed loop transmit diversity mode.....	858
E.3.6	OCNS Definition.....	858
E.4	W-CDMA Modulated Interferer for non-HSDPA test cases.....	859
E.5	HSDPA DL Physical channels.....	859
E.5.0	Downlink Physical Channels for connection set-up.....	859
E.5.1	Downlink Physical Channels for measurement.....	859
E.5.2	HSDPA OCNS Definition.....	864
E.5.3	Downlink Physical Channels for measurement including test tolerances.....	865
E.5.4	Downlink Physical Channels for Transmitter Characteristics with HS-DPCCH.....	866
E.5A	E-DCH with HSDPA DL Physical channels.....	867
E.5A.0	Downlink Physical Channels for connection set-up.....	867
E.5A.1	Downlink Physical Channels for measurement.....	867
E.5A.2	E-DCH OCNS Definition.....	869
E.5B	MBMS DL Physical channels.....	869
E.5B.1	Downlink Physical Channels for connection set-up.....	869
E.6	Downlink Physical Channels Code Allocation (This clause is informative).....	871
E.6.1	Downlink Physical Channels Code Allocation for non-HSDPA test cases.....	871
E.6.2	Downlink Physical Channels Code Allocation for HSDPA test cases.....	873
E.6.3	Downlink Physical Channels Code Allocation for E-DCH test cases.....	876
E.6.4	Downlink Physical Channels Code Allocation for MBMS test cases.....	878
Annex F (normative): General test conditions and declarations.....		880
F.1	Acceptable uncertainty of Test System.....	880
F.1.1	Measurement of test environments.....	880
F.1.2	Measurement of transmitter.....	881
F.1.3	Measurement of receiver.....	884
F.1.4	Performance requirement.....	886
F.1.5	Requirements for support of RRM.....	891
F.1.6	Performance requirement (HSDPA).....	914
F.1.7	Performance requirement (E-DCH).....	917
F.1.8	Performance requirement (MBMS).....	919
F.2	Test Tolerances (This clause is informative).....	920
F.2.1	Transmitter.....	920
F.2.2	Receiver.....	921
F.2.3	Performance requirements.....	922
F.2.4	Requirements for support of RRM.....	924
F.2.5	Performance requirements (HSDPA).....	930
F.2.6	Performance requirements (E-DCH).....	931
F.2.7	Performance requirements (MBMS).....	932
F.3	Interpretation of measurement results.....	932
F.4	Derivation of Test Requirements (This clause is informative).....	932
F.4.1	Transmitter.....	933
F.4.2	Receiver.....	940
F.4.3	Performance requirements.....	942
F.4.4	Requirements for support of RRM.....	950
F.4.5	Performance requirements (HSDPA).....	976
F.4.6	Performance requirements (E-DCH).....	978
F.4.7	Performance requirements (MBMS).....	980
F.5	Acceptable uncertainty of Test Equipment (This clause is informative).....	980
F.5.1	Transmitter measurements.....	981
F.5.2	Receiver measurements.....	982
F.5.3	Performance measurements.....	982
F.5.4	Requirements for support of RRM.....	983
F.5.5	Performance measurements (HSDPA).....	983
F.5.6	Performance measurements (E-DCH).....	984

F.6	General rules for statistical testing	985
F.6.1	Statistical testing of receiver BER/BLER performance	985
F.6.1.1	Error Definition	985
F.6.1.2	Test Method	985
F.6.1.3	Test Criteria	985
F.6.1.4	Calculation assumptions	986
F.6.1.4.1	Statistical independence	986
F.6.1.4.2	Applied formulas	986
F.6.1.4.3	Approximation of the distribution	986
F.6.1.5	Definition of good pass fail decision.	986
F.6.1.6	Good balance between testtime and statistical significance	987
F.6.1.7	Pass fail decision rules	988
F.6.1.8	Test conditions for BER, BLER, RLC SDU Error Rate tests	989
F.6.1.9	Practical Use (informative)	992
F.6.1.10	Dual limit BLER tests	994
F.6.1.10.1	Description of the parameters for dual limit BLER tests	995
F.6.1.10.2	Pass fail decision rules	997
F.6.1.10.3	Test conditions for dual limit BLER tests	998
F.6.2	Statistical testing of RRM delay performance	998
F.6.2.1	Test Method	998
F.6.2.2	Bad Delay Ratio (ER)	999
F.6.2.3	Test Criteria	999
F.6.2.4	Calculation assumptions	999
F.6.2.4.1	Statistical independence	999
F.6.2.4.2	Applied formulas	999
F.6.2.4.3	Approximation of the distribution	999
F.6.2.5	Definition of good pass fail decision	1000
F.6.2.6	Good balance between test-time and statistical significance	1000
F.6.2.7	Pass fail decision rules	1001
F.6.2.8	Test conditions for RRM delay tests, Combining of TPC commands test 1, Demodulation of Paging channel and Detection of acquisition indicator tests	1002
F.6.2.9	Practical Use (informative)	1003
F.6.3	Statistical Testing of HSDPA Receiver Performance	1004
F.6.3.1	Definition	1004
F.6.3.2	Mapping throughput to block error ratio	1004
F.6.3.3	Bad DUT factor	1005
F.6.3.3.1	Bad DUT factor, range of applicability	1006
F.6.3.4	Minimum Test time	1007
F.5.7	Performance measurements (MBMS)	1024
F.6.4	Statistical testing of performance requirement (E-DCH)	1024
F.6.4.1	Test Method	1024
F.6.4.2	Bad Result Ratio (ER)	1024
F.6.4.3	Mapping of E-DCH tests to RRM tests (F.6.2) and HSDPA tests (F.6.3)	1024
F.6.4.4	Test conditions for E-DCH tests	1025
Annex G (normative): Environmental conditions		1026
G.1	General	1026
G.2	Environmental requirements	1026
G.2.1	Temperature	1026
G.2.2	Voltage	1026
G.2.3	Vibration	1027
G.2.4	Specified frequency range	1027
Annex H (normative): UE Capabilities (FDD)		1028
H.1	Void	1028
H.2	Void	1028
Annex I (normative): Default Message Contents		1029
Contents of MEASUREMENT REPORT message for Intra frequency test cases		1029

Contents of MEASUREMENT REPORT message for Inter frequency test cases.....	1030
Contents of MEASUREMENT REPORT message for inter – RAT test cases.....	1031
Contents of RRC CONNECTION SETUP message: UM (Transition to CELL_DCH)	1031
Contents of Master Information Block PLMN type is the case of GSM-MAP	1032
Contents of Scheduling Block 1 (FDD)	1032
Contents of Scheduling Block 1 (FDD)	1033
Contents of System Information Block type 11 (FDD).....	1033
Contents of System Information Block type 11 (FDD).....	1034
Contents of System Information Block type 11 (FDD).....	1034
Contents of System Information Block type 11 (FDD).....	1035
Contents of Scheduling Block 1 (FDD)	1035
Contents of System Information Block type 11 (FDD).....	1036
Contents of System Information Block type 11 (FDD).....	1037
Contents of Scheduling Block 1 (FDD)	1037
Contents of System Information Block type 11 (FDD).....	1038
Contents of System Information Block type 11 (FDD).....	1038
Contents of TRANSPORT CHANNEL RECONFIGURATION message for test cases with HSDPA in clauses 5.2A, 5.2C, 5.7A, 5.9A, 5.10A and 5.13.1A (Rel-5 and later releases).	1040
Contents of ACTIVE SET UPDATE message for test cases with SHO in clauses 7.7.1, 7.7.1A, 7.7.2, and 7.7.3.	1042
Annex J (informative): Information about special regional application of test cases and requirements.....	1045
J.1 Japan.....	1045
Annex K (normative): Cell configuration mapping	1046
Annex L (informative): Change history	1050
History	1072

Foreword

This Technical Specification has been produced by the 3rd Generation Partnership Project (3GPP).

The contents of the present document are subject to continuing work within the TSG and may change following formal TSG approval. Should the TSG modify the contents of the present document, it will be re-released by the TSG with an identifying change of release date and an increase in version number as follows:

Version x.y.z

where:

- x the first digit:
 - 1 presented to TSG for information;
 - 2 presented to TSG for approval;
 - 3 or greater indicates TSG approved document under change control.
- y the second digit is incremented for all changes of substance, i.e. technical enhancements, corrections, updates, etc.
- z the third digit is incremented when editorial only changes have been incorporated in the document.

Introduction

The present document is part 1 of a multi-parts TS:

3GPP TS 34.121-1: User Equipment (UE) conformance specification; Radio transmission and reception (FDD); Part 1: Conformance specification.

3GPP TS 34.121-2 [32]: User Equipment (UE) conformance specification; Radio transmission and reception (FDD); Part 2: Implementation Conformance Statement (ICS).

NOTE: TS 34.121 has been converted to multipart TS with version 7.0.0. Previous versions are a single part standard 34.121.

1 Scope

The present document specifies the measurement procedures for the conformance test of the user equipment (UE) that contain transmitting characteristics, receiving characteristics and performance requirements in addition to requirements for support of RRM (Radio Resource Management) in FDD mode.

The requirements are listed in different clauses only if the corresponding parameters deviate. More generally, tests are only applicable to those mobiles that are intended to support the appropriate functionality. To indicate the circumstances in which tests apply, this is noted in the “*definition and applicability*” part of the test.

For example only Release 5 and later UE declared to support HSDPA shall be tested for this functionality. In the event that for some tests different conditions apply for different releases, this is indicated within the text of the test itself.

2 References

The following documents contain provisions which, through reference in this text, constitute provisions of the present document.

- References are either specific (identified by date of publication, edition number, version number, etc.) or non-specific.
- For a specific reference, subsequent revisions do not apply.
- For a non-specific reference, the latest version applies. In the case of a reference to a 3GPP document (including a GSM document), a non-specific reference implicitly refers to the latest version of that document.

- For a Release 1999 UE, references to 3GPP documents are to version 3.x.y.

- For a Release 4 UE, references to 3GPP documents are to version 4.x.y.

- For a Release 5 UE, references to 3GPP documents are to version 5.x.y.

- For a Release 6 UE, references to 3GPP documents are to version 6.x.y.

- For a Release 7 UE, references to 3GPP documents are to version 7.x.y.

[1] 3GPP TS 25.101 "UE Radio transmission and reception (FDD)".

[2] 3GPP TS 25.133 "Requirements for Support of Radio Resource Management (FDD)".

[3] 3GPP TS 34.108 "Common Test Environments for User Equipment (UE) Conformance Testing".

[4] 3GPP TS 34.109 "Terminal logical test interface; Special conformance testing functions".

[5] 3GPP TS 25.214 "Physical layer procedures (FDD)".

[6] 3GPP TR 21.905 "Vocabulary for 3GPP Specifications".

[7] 3GPP TR 25.990 "Vocabulary".

[8] 3GPP TS 25.331: "Radio Resource Control (RRC); Protocol Specification".

[9] 3GPP TS 25.433 "UTRAN Iub Interface NBAP Signalling".

[10] ITU-R Recommendation SM.329: "Spurious emissions".

[11] 3GPP TS 25.304: "UE Procedures in Idle Mode and Procedures for Cell Reselection in Connected Mode".

[12] 3GPP TS 25.303: "Interlayer Procedures in Connected Mode".

[13] 3GPP TS 25.321: "Medium Access Control (MAC) protocol specification".

[14] 3GPP TS 25.213: "Spreading and modulation (FDD)".

- [15] 3GPP TS 25.223: "Spreading and modulation (TDD)".
- [16] ETSI ETR 273-1-2: "Improvement of radiated methods of measurement (using test sites) and evaluation of the corresponding measurement uncertainties; Part 1: Uncertainties in the measurement of mobile radio equipment characteristics; Sub-part 2: Examples and annexes".
- [17] 3GPP TR 25.926: "UE Radio Access Capabilities".
- [18] 3GPP TR 21.904: "UE capability requirements".
- [19] 3GPP TS 25.211: "Physical channels and mapping of transport channels onto physical channels (FDD)".
- [20] 3GPP TS 05.08 (R99): "Technical Specification Group GSM/EDGE Radio Access Network; Radio subsystem link control".
- [21] 3GPP TS 34.123-1: "User Equipment (UE) Conformance Specification; Part 1: Protocol Conformance Specification".
- [22] 3GPP TS 25.215: "Physical Layer – Measurements (FDD)".
- [23] Void
- [24] 3GPP TR 34.902 " Derivation of test tolerances for multi-cell Radio Resource Management (RRM) conformance tests ".
- [25] 3GPP TS 51.010-1: "Mobile Station (MS) conformance specification; Part 1: Conformance specification ".
- [26] 3GPP TS 25.307 "Requirements on UEs supporting a release independent frequency band".
- [27] ITU-T recommendation O.153: "Basic parameters for the measurement of error performance at bit rates below the primary rate".
- [28] 3GPP TS 05.05 (R99): "Technical Specification Group GSM/EDGE Radio Access Network; Radio transmission and reception".
- [29] 3GPP TS 45.005 (Rel-4 and later releases): "Technical Specification Group GSM/EDGE Radio Access Network; Radio transmission and reception".
- [30] 3GPP TS 45.008 (Rel-4 and later releases): "Technical Specification Group GSM/EDGE Radio Access Network; Radio subsystem link control".
- [31] 3GPP TS 25.212: "Multiplexing and channel coding (FDD)".
- [32] 3GPP TS 34.121-2: " User Equipment (UE) conformance specification; Radio transmission and reception (FDD); Part 2: Implementation Conformance Statement (ICS)".

3 Definitions, symbols, abbreviations and equations

Definitions, symbols, abbreviations and equations used in the present document are listed in TR 21.905 [5] and TR 25.990 [6].

Terms are listed in alphabetical order in this clause.

3.1 Definitions

For the purpose of the present document, the following additional terms and definitions apply:

Maximum Output Power: This is a measure of the maximum power the UE can transmit (i.e. the actual power as would be measured assuming no measurement error) in a bandwidth of at least $(1 + \alpha)$ times the chip rate of the radio access mode. The period of measurement shall be at least one timeslot.

Nominal Maximum Output Power: This is the nominal power defined by the UE power class.

Mean power: When applied to a W-CDMA modulated signal this is the power (transmitted or received) in a bandwidth of at least $(1 + \alpha)$ times the chip rate of the radio access mode. The period of measurement shall be at least one timeslot unless otherwise stated.

RRC filtered mean power: The mean power as measured through a root raised cosine filter with roll-off factor α and a bandwidth equal to the chip rate of the radio access mode.

NOTE 1: The RRC filtered mean power of a perfectly modulated W-CDMA signal is 0.246 dB lower than the mean power of the same signal.

NOTE 2: The roll-off factor α is defined in 25.101 clause 6.8.1.

RegDTX: Regular DTX. These are the times when the HS-DPCCH ACK/NACK is not expected to be transmitted due to an Inter-TTI period greater than 1

statDTX: Statistical DTX. These are the times when the HS-DPCCH is expected to transmit an ACK or NACK but none is transmitted due to the UE not being able to decode consistent control information from the HS_SCCH.

Throughput: Number of information bits per second excluding CRC bits successfully received on HS-DSCH by a HSDPA capable UE.

Enhanced performance requirements type 1: This defines performance requirements which are optional for the UE. The requirements are based on UEs which utilise receiver diversity.

Enhanced performance requirements type 2: This defines performance requirements which are optional for the UE. The requirements are based on UEs which utilise a chip equaliser receiver structure.

3.2 Symbols

For the purposes of the present document, the following symbols apply:

[...] Values included in square bracket must be considered for further studies, because it means that a decision about that value was not taken

3.3 Abbreviations

For the purpose of the present document, the following additional abbreviations apply:

AFC	Automatic Frequency Control
ASD	Acceleration Spectral Density
ATT	Attenuator
BER	Bit Error Ratio
BLER	Block Error Ratio
BTFD	Blind Transport Format Detection
CQI	Channel Quality Indicator
EVM	Error Vector Magnitude
FDR	False transmit format Detection Ratio. A false Transport Format detection occurs when the receiver detects a different TF to that which was transmitted, and the decoded transport block(s) for this incorrect TF passes the CRC check(s).
HSDPA	High Speed Downlink Packet Access
HS-DSCH	High Speed Downlink Shared Channel
HS-PDSCH	High Speed Physical Downlink Shared Channel
HARQ	Hybrid ARQ sequence
HYB	Hybrid
IM	Intermodulation
ITP	Initial Transmission Power control mode
OBW	Occupied Bandwidth
OCNS	Orthogonal Channel Noise Simulator, a mechanism used to simulate the users or control signals on the other orthogonal channels of a downlink
PAR	Peak to Average Ratio
P-CCPCH	Primary Common Control Physical Channel
P-CPICH	Primary Common Pilot Channel

PCDE	Peak Code Domain Error
RBW	Resolution Bandwidth
PRBS	Pseudo Random Bit Sequence
regDTX	Regular DTX
RRC	Root-Raised Cosine
S-CCPCH	Secondary Common Control Physical Channel
S-CPICH	Secondary Common Pilot Channel
SCH	Synchronisation Channel consisting of Primary and Secondary synchronisation channels
SS	System Simulator; see Annex A for description
statDTX	Statistical DTX
TGCFN	Transmission Gap Connection Frame Number
TGD	Transmission Gap Distance
TGL	Transmission Gap Length
TGPL	Transmission Gap Pattern Length
TGPRC	Transmission Gap Pattern Repetition Count
TGSN	Transmission Gap Starting Slot Number

3.4 Equations

For the purpose of the present document, the following additional equations apply:

$\frac{CPICH_E_c}{I_{or}}$ The ratio of the received energy per PN chip of the CPICH to the total transmit power spectral density at the Node B (SS) antenna connector.

$\frac{DPCH_E_c}{I_{or}}$ The ratio of the transmit energy per PN chip of the DPCH to the total transmit power spectral density at the Node B (SS) antenna connector.

$\frac{DPCCH_E_c}{I_{or}}$ The ratio of the transmit energy per PN chip of the DPCCH to the total transmit power spectral density at the Node B (SS) antenna connector.

$\frac{DPDCH_E_c}{I_{or}}$ The ratio of the transmit energy per PN chip of the DPDCH to the total transmit power spectral density at the Node B (SS) antenna connector.

F_{uw} Frequency of unwanted signal. This is specified in bracket in terms of an absolute frequency(s) or a frequency offset from the assigned channel frequency.

I_{Node_B} Interference signal power level at Node B in dBm, which is broadcasted on BCH.

I_{oac} The power spectral density (integrated in a bandwidth of $(1+\alpha)$ times the chip rate and normalized to the chip rate) of the adjacent frequency channel as measured at the UE antenna connector.

I_{oc} The power spectral density (integrated in a noise bandwidth equal to the chip rate and normalized to the chip rate) of a band limited white noise source (simulating interference from cells, which are not defined in a test procedure) as measured at the UE antenna connector.

I_{or} The total transmit power spectral density (integrated in a bandwidth of $(1+\alpha)$ times the chip rate and normalized to the chip rate) of the downlink signal at the Node B antenna connector

\hat{I}_{or} The received power spectral density (integrated in a bandwidth of $(1+\alpha)$ times the chip rate and normalized to the chip rate) of the downlink signal as measured at the UE antenna connector.

I_{ouw} Unwanted signal power level.

$P\text{-}CCPCH_E_c$ Average (note) energy per PN chip for P-CCPCH.

$P\text{-}CCPCH \frac{E_c}{I_o}$ The ratio of the received P-CCPCH energy per chip to the total received power spectral density at the UE antenna connector.

$\frac{P-CCPCH_E_c}{I_{or}}$	The ratio of the average (note) transmit energy per PN chip for the P-CCPCH to the total transmit power spectral density.
$P-CPICH_E_c$	Average (note) energy per PN chip for P-CPICH.
$PICH_E_c$	Average (note) energy per PN chip for PICH.
$\frac{PICH_E_c}{I_{or}}$	The ratio of the received energy per PN chip of the PICH to the total transmit power spectral density at the Node B (SS) antenna connector.
R	Number of information bits per second excluding CRC bits successfully received on HS-DSCH by a HSDPA capable UE.
<REFSENS>	Reference sensitivity
<REF \hat{I}_{or} >	Reference \hat{I}_{or}
SCH_E_c	Average (note) energy per PN chip for SCH.
$S-CPICH_E_c$	Average (note) energy per PN chip for S-CPICH.

NOTE: Averaging period for energy/power of discontinuously transmitted channels should be defined.

NOTE: The units of Power Spectral Density (PSD) are extensively used in this document. PSD is a function of power versus frequency and when integrated across a given bandwidth, the function represents the mean power in such a bandwidth. When the mean power is normalised to (divided by) the chip-rate it represents the mean energy per chip. Some signals are directly defined in terms of energy per chip, (DPCH_ E_c and P-CPICH_ E_c) and others defined in terms of PSD (I_{oac} , I_{oc} , and \hat{I}_{or}). There also exist quantities that are a ratio of energy per chip to PSD (DPCH_ E_c/I_{or} , E_c/I_{or} etc.). This is the common practice of relating energy magnitudes in communication systems.

It can be seen that if both energy magnitudes in the ratio are divided by time, the ratio is converted from an energy ratio to a power ratio, which is more useful from a measurement point of view. It follows that an energy per chip of X dBm/3.84 MHz can be expressed as a mean power per chip of X dBm. Similarly, a signal PSD of Y dBm/3.84 MHz can be expressed as a signal power of Y dBm.

4 Frequency bands and channel arrangement

4.1 General

The information presented in this clause is based on a chip rate of 3,84 Mcps.

NOTE: Other chip rates may be considered in future releases.

4.2 Frequency bands

a) UTRA/FDD is designed to operate in either of the following paired bands:

Operating Band	UL Frequencies UE transmit, Node B receive	DL frequencies UE receive, Node B transmit
I	1920 – 1980 MHz	2110 – 2170 MHz
II	1850 – 1910 MHz	1930 – 1990 MHz
III	1710 - 1785 MHz	1805 - 1880 MHz
IV	1710 - 1755MHz	2110 - 2155MHz
V	824 - 849MHz	869 - 894MHz
VI	830 - 840 MHz	875 - 885 MHz
VII	2500 - 2570 MHz	2620 - 2690 MHz
VIII	880 – 915 MHz	925 – 960 MHz
IX	1749.9 - 1784.9 MHz	1844.9 - 1879.9 MHz
X	1710 – 1770 MHz	2110 – 2170 MHz
XI	1427.9 - 1452.9 MHz	1475.9 - 1500.9 MHz

Note: See TS25.307 [26] for Band IV, V, VI, VII, VIII and IX.

b) Deployment in other frequency bands is not precluded.

4.3 TX–RX frequency separation

a) UTRA/FDD is designed to operate with the following TX-RX frequency separation.

Operating Band	TX-RX frequency separation
I	190 MHz
II	80 MHz
III	95 MHz
IV	400 MHz
V	45 MHz
VI	45 MHz
VII	120 MHz
VIII	45 MHz
IX	95 MHz
X	400 MHz
XI	48 MHz

b) UTRA/FDD can support both fixed and variable transmit to receive frequency separation.

c) The use of other transmit to receive frequency separations in existing or other frequency bands shall not be precluded.

4.4 Channel arrangement

4.4.1 Channel spacing

The nominal channel spacing is 5 MHz, but this can be adjusted to optimise performance in a particular deployment scenario.

4.4.2 Channel raster

The channel raster is 200 kHz, for all bands which means that the centre frequency must be an integer multiple of 200 kHz. In addition a number of additional centre frequencies are specified according to table 4.1a, which means that the centre frequencies for these channels are shifted 100 kHz relative to the general raster.

4.4.3 Channel number

The carrier frequency is designated by the UTRA Absolute Radio Frequency Channel Number (UARFCN). For each operating Band, the values of the UARFCN are defined as follows.

Uplink: $N_U = 5 * (F_{UL} - F_{UL_Offset})$, for the carrier frequency range $F_{UL_low} \leq F_{UL} \leq F_{UL_high}$

Downlink: $N_D = 5 * (F_{DL} - F_{DL_Offset})$, for the carrier frequency range $F_{DL_low} \leq F_{DL} \leq F_{DL_high}$

For each operating Band, F_{UL_Offset} , F_{UL_low} , F_{UL_high} , F_{DL_Offset} , F_{DL_low} and F_{DL_high} are defined in Table 4.1 for the general UARFCN. For the additional UARFCN, F_{UL_Offset} , F_{DL_Offset} and the specific F_{UL} and F_{DL} are defined in Table 4.1A.

Table 4.1: UARFCN definition (general)

Band	UPLINK (UL) UE transmit, Node B receive			DOWNLINK (DL) UE receive, Node B transmit		
	UARFCN formula offset F_{UL_Offset} [MHz]	Carrier frequency (F_{UL}) range [MHz]		UARFCN formula offset F_{DL_Offset} [MHz]	Carrier frequency (F_{DL}) range [MHz]	
		F_{UL_low}	F_{UL_high}		F_{DL_low}	F_{DL_high}
I	0	1922.4	1977.6	0	2112.4	2167.6
II	0	1852.4	1907.6	0	1932.4	1987.6
III	1525	1712.4	1782.6	1575	1807.4	1877.6
IV	1450	1712.4	1752.6	1805	2112.4	2152.6
V	0	826.4	846.6	0	871.4	891.6
VI	0	832.4	837.6	0	877.4	882.6
VII	2100	2502.4	2567.6	2175	2622.4	2687.6
VIII	340	882.4	912.6	340	927.4	957.6
IX	0	1752.4	1782.4	0	1847.4	1877.4
X	1135	1712.4	1767.6	1490	2112.4	2167.6
XI	733	1430.4	1450.4	736	1478.4	1498.4

Table 4.1a: UARFCN definition (additional channels)

Band	UPLINK (UL) UE transmit, Node B receive		DOWNLINK (DL) UE receive, Node B transmit	
	UARFCN formula offset F_{UL_Offset} [MHz]	Carrier frequency [MHz] (F_{UL})	UARFCN formula offset F_{DL_Offset} [MHz]	Carrier frequency [MHz] (F_{DL})
I	-	-	-	-
II	1850.1	1852.5, 1857.5, 1862.5, 1867.5, 1872.5, 1877.5, 1882.5, 1887.5, 1892.5, 1897.5, 1902.5, 1907.5	1850.1	1932.5, 1937.5, 1942.5, 1947.5, 1952.5, 1957.5, 1962.5, 1967.5, 1972.5, 1977.5, 1982.5, 1987.5
III	-	-	-	-
IV	1380.1	1712.5, 1717.5, 1722.5, 1727.5, 1732.5, 1737.5, 1742.5, 1747.5, 1752.5	1735.1	2112.5, 2117.5, 2122.5, 2127.5, 2132.5, 2137.5, 2142.5, 2147.5, 2152.5
V	670.1	826.5, 827.5, 831.5, 832.5, 837.5, 842.5	670.1	871.5, 872.5, 876.5, 877.5, 882.5, 887.5
VI	670.1	832.5, 837.5	670.1	877.5, 882.5
VII	2030.1	2502.5, 2507.5, 2512.5, 2517.5, 2522.5, 2527.5, 2532.5, 2537.5, 2542.5, 2547.5, 2552.5, 2557.5, 2562.5, 2567.5	2105.1	2622.5, 2627.5, 2632.5, 2637.5, 2642.5, 2647.5, 2652.5, 2657.5, 2662.5, 2667.5, 2672.5, 2677.5, 2682.5, 2687.5
VIII	-	-	-	-
IX	-	-	-	-
X	1075.1	1712.5, 1717.5, 1722.5, 1727.5, 1732.5, 1737.5, 1742.5, 1747.5, 1752.5, 1757.5, 1762.5, 1767.5	1430.1	2112.5, 2117.5, 2122.5, 2127.5, 2132.5, 2137.5, 2142.5, 2147.5, 2152.5, 2157.5, 2162.5, 2167.5
XI	-	-	-	-

4.4.4 UARFCN

The following UARFCN range shall be supported for each paired band.

Table 4.2: UTRA Absolute Radio Frequency Channel Number

Operating Band	Uplink UE transmit, Node B receive	Downlink UE receive, Node B transmit
I	9 612 to 9 888	10 562 to 10 838
II	9 262 to 9 538 and 12, 37, 62, 87, 112, 137, 162, 187, 212, 237, 262, 287	9 662 to 9 938 and 412, 437, 462, 487, 512, 537, 562, 587, 612, 637, 662, 687
III	937 to 1288	1162 to 1513
IV	1312 to 1513 and 1662, 1687, 1712, 1737, 1762, 1787, 1812, 1837, 1862	1537 to 1738 and 1887, 1912, 1937, 1962, 1987, 2012, 2037, 2062, 2087
V	4132 to 4233 and 782, 787, 807, 812, 837, 862	4357 to 4458 and 1007, 1012, 1032, 1037, 1062, 1087
VI	4162 to 4188 and 812, 837	4387 to 4413 and 1037, 1062
VII	2012 to 2338 and 2362, 2387, 2412, 2437, 2462, 2487, 2512, 2537, 2562, 2587, 2612, 2637, 2662, 2687	2237 to 2563 and 2587, 2612, 2637, 2662, 2687, 2712, 2737, 2762, 2787, 2812, 2837, 2862, 2887, 2912
VIII	2712 to 2863	2937 to 3088
IX	8762 to 8912	9237 to 9387
X	2887 to 3163 and 3187, 3212, 3237, 3262, 3287, 3312, 3337, 3362, 3387, 3412, 3437, 3462	3112 to 3388 and 3412, 3437, 3462, 3487, 3512, 3537, 3562, 3587, 3612, 3637, 3662, 3687
XI	3487 to 3587	3712 to 3812

4A Reference Conditions

The reference environment used by all test cases in this document are specified in TS 34.108 [3]. Where a test requires an environment that is different, this will be specified in the test itself.

4A.1 Generic setup procedures

Test procedures for RF test are defined in TS 34.108 [3] clause 7.3. The initial conditions of this clause also refer to the generic setup procedures defined in TS 34.108 [3] clause 7.2.

4A.2 System information

The reference system information used for test cases specified in this document is defined in TS 34.108 [3] clauses 6.1.0a (Default Master Information Block and Scheduling Block messages) and 6.1.0b (Default System Information Block Messages). For cells other than cell 1 the difference in information elements is defined in TS 34.108 [3] clause 6.1.4. For the generic setup procedures defined in TS 34.108 [3] clause 7.3 some SIB elements override those specific SIB elements from TS 34.108 [3] clause 6.1.0b. Annex I in the present document overwrites specific elements in the Master Information Block and Scheduling Block messages compared to TS 34.108 [3] clause 6.1.0a and specific SIB elements compared to TS 34.108 [3] clauses 6.1.0b and 7.3. In the test description itself specific SIB elements can be overwritten again. This leads to the following places defining Master Information Block, Scheduling Block messages and System Information Block Messages:

1. TS 34.108 [3] clauses 6.1.0a, 6.1.0b and 6.1.4
2. TS 34.108 [3] clause 7.3
3. TS 34.121 Annex I
4. TS 34.121 test case description

When the same Information Element is defined in several places then the place with the higher number according to the above list will override the other definition(s).

4A.3 Message contents

Default message contents for test cases specified in this document are defined in TS 34.108 [3] clause 9. Most default message contents are specified in TS 34.108 [3] clause 9.2.1, but some default message contents originally defined for signalling test cases are re-used for RF testing and specified in TS 34.108 [3] clause 9.1.1. TS 34.108 [3] clause 7.3 contains additional information regarding the default messages. Annex I in the present document overwrites specific message contents for some test cases. In the test description itself specific information elements can be overwritten again. This leads to the following places defining message contents:

- 1a. TS 34.108 [3] clause 9.1.1 (only if indicated by TS 34.108 [3] clause 7.3 or the test description in TS 34.121)
- 1b. TS 34.108 [3] clause 9.2.1 (as indicated by TS 34.108 [3] clause 7.3 or the test description in TS 34.121)
2. TS 34.108 [3] clause 7.3
3. TS 34.121 Annex I
4. TS 34.121 test case description

When the same Information Element is defined in several places then the place with the higher number according to the above list will override the other definition(s). Default message contents from TS 34.108 [3] clause 9 will be used either from clause 9.1.1 (1a in the list above) or from clause 9.2.1 (1b in the list above). Some messages are not defined in all places, but all messages have to be defined at least in the test description.

4A.4 Measurement configurations

Measurement configurations defined by system information are specified in TS 34.108 [3]. System Information Block type 11 (SIB 11) configures measurements for cell 1 according to TS 34.108 [3] clause 6.1.0b. See TS 34.108 [3] clause 6.1.4 for the difference in message contents of SIB 11 (FDD) for other cells used in the test. SIB 12 is specified in TS 34.108 [3] clause 6.1.0b, but is currently not used to configure measurements.

Some modifications to specific information elements in SIB 11 are defined in TS 34.121 Annex I or in the test description itself. In this case the priority defined in clause 4A.2 shall be applied.

Note: Currently SIB 11 in TS 34.108 [3] configures Intra-frequency measurement system information to use “Intra-frequency measurement identity=1” (default value), “Intra-frequency measurement identity =CPICH RSCP” with events 1a, 1b and 1c. The Inter-frequency measurement system information and the Inter-RAT measurement system information do not configure measurement identities. Traffic volume measurement system information is not present.

In many test cases the measurement identity as configured by SIB 11 is reused and the Measurement Control message will “Modify” the Measurement Identity configured in SIB 11.

In some test cases additional measurements are used. Then the Measurement Control message will “Setup” a new Measurement Identity with the default value for that measurement quantity as specified in TS 25.331 [8]. If the Measurement Control message uses “Setup” then the new Measurement Identity shall be different to already configured ones. All Inter-frequency measurements and Inter-RAT measurements are first configured by Measurement Control message using “Setup”.

All UE measurements are referenced to the UE antenna connector.

5 Transmitter Characteristics

5.1 General

Transmitting performance test of the UE is implemented during communicating with the SS via air interface. The procedure is using normal call protocol until the UE is communicating on traffic channel basically. On the traffic channel, the UE provides special function for testing that is called Logical Test Interface and the UE is tested using this function. (Refer to TS 34.109 [4]).

Transmitting or receiving bit/symbol rate for test channel is shown in table 5.1.

Table 5.1: Bit / Symbol rate for Test Channel

Type of User Information	User bit rate	DL DPCH symbol rate	UL DPCH bit rate	Remarks
12,2 kbps reference measurement channel	12,2 kbps	30 ksps	60 kbps	Standard Test

Unless detailed the transmitter characteristic are specified at the antenna connector of the UE. For UE with integral antenna only, a reference antenna with a gain of 0 dBi is assumed. Transmitter characteristics for UE(s) with multiple antennas/antenna connectors are FFS.

The UE antenna performance has a significant impact on system performance, and minimum requirements on the antenna efficiency are therefore intended to be included in future versions of the present document. It is recognised that different requirements and test methods are likely to be required for the different types of UE.

All the parameters in clause 5 are defined using the UL reference measurement channel (12,2 kbps) specified in clause C.2.1 and unless stated otherwise, with the UL power control ON.

The common RF test conditions of Tx Characteristics are defined in clause E.3.1, and each test conditions in this clause (clause 5) should refer clause E.3.1. Individual test conditions are defined in the paragraph of each test.

When DCCH has been configured on downlink DCH then DCCH Data shall be continuously transmitted on downlink DCH during the measurement period. When there is no signalling to transmit on downlink DCCH then dummy DCCH transmission as described in Annex C.9 shall be used.

For HSDPA test cases and E-DCH test cases, when DTCH has been configured on downlink DCH then DTCH Data shall be continuously transmitted on downlink DCH during the measurement period.

The MAC header transmission on HS-DSCH for all E-DCH test cases shall use a correct MAC-hs header consistent with the actual HSDPA transmission.

The DL and UL RLC SDU size for all E-DCH tests in clause 5 shall be set according to Annex C.11.3.

For HSDPA test cases without E-DCH, the MAC headers on HS-DSCH shall be according to Annex C.9A.

5.2 Maximum Output Power

5.2.1 Definition and applicability

The nominal maximum output power and its tolerance are defined according to the Power Class of the UE.

The maximum output power is a measure of the maximum power the UE can transmit (i.e. the actual power as would be measured assuming no measurement error) in a bandwidth of at least $(1 + \alpha)$ times the chip rate of the radio access mode. The period of measurement shall be at least one timeslot.

The requirements and this test apply to all types of UTRA for the FDD UE.

5.2.2 Minimum Requirements

The UE maximum output power shall be within the nominal value and tolerance specified in table 5.2.1 even for the multi-code transmission mode.

Table 5.2.1: Nominal Maximum Output Power

Operating Band	Power Class 1		Power Class 2		Power Class 3		Power Class 3bis		Power Class 4	
	Power (dBm)	Tol (dB)	Power (dBm)	Tol (dB)	Power (dBm)	Tol (dB)	Power (dBm)	Tol (dB)	Power (dBm)	Tol (dB)
Band I	+33	+1/-3	+27	+1/-3	+24	+1/-3	-	-	+21	+2/-2
Band II	-	-	-	-	+24	+1/-3	-	-	+21	+2/-2
Band III	-	-	-	-	+24	+1/-3	-	-	+21	+2/-2
Band IV	-	-	-	-	+24	+1/-3	-	-	+21	+2/-2
Band V	-	-	-	-	+24	+1/-3	-	-	+21	+2/-2
Band VI	-	-	-	-	+24	+1/-3	-	-	+21	+2/-2
Band VII	-	-	-	-	+24	+1/-3	+23	+2/-2	+21	+2/-2
Band VIII	-	-	-	-	+24	+1/-3	+23	+2/-2	+21	+2/-2
Band IX	-	-	-	-	+24	+1/-3	-	-	+21	+2/-2
Band X	-	-	-	-	+24	+1/-3	-	-	+21	+2/-2
Band XI	-	-	-	-	+24	+1/-3	-	-	+21	+2/-2

The normative reference for this requirement is TS 25.101 [1] clause 6.2.1.

5.2.3 Test purpose

To verify that the error of the UE maximum output power does not exceed the range prescribed by the nominal maximum output power and tolerance in table 5.2.1.

An excess maximum output power has the possibility to interfere to other channels or other systems. A small maximum output power decreases the coverage area.

5.2.4 Method of test

5.2.4.1 Initial conditions

Test environment: normal, TL/VL, TL/VH, TH/VL, TH/VH; see clauses G.2.1 and G.2.2.

Frequencies to be tested: low range, mid range, high range; see clause G.2.4.

- 1) Connect the SS to the UE antenna connector as shown in figure A.1.
- 2) A call is set up according to the Generic call setup procedure in TS34.108 [3] sub clause 7.3.2.
- 3) Enter the UE into loopback test mode and start the loopback test.

See TS 34.108 [3] and TS 34.109 [4] for details regarding generic call setup procedure and loopback test.

5.2.4.2 Procedure

- 1) Set and send continuously Up power control commands to the UE.
- 2) Measure the mean power of the UE in a bandwidth of at least $(1 + \alpha)$ times the chip rate of the radio access mode. The mean power shall be averaged over at least one timeslot.

5.2.5 Test requirements

The maximum output power, derived in step 2), shall not exceed the range prescribed by the nominal maximum output power and tolerance in table 5.2.2.

Table 5.2.2: Nominal Maximum Output Power

Operating Band	Power Class 1		Power Class 2		Power Class 3		Power Class 3bis		Power Class 4	
	Power (dBm)	Tol (dB)	Power (dBm)	Tol (dB)	Power (dBm)	Tol (dB)	Power (dBm)	Tol (dB)	Power (dBm)	Tol (dB)
Band I	+33	+1,7/-3,7	+27	+1,7/-3,7	+24	+1,7/-3,7	-	-	+21	+2,7/-2,7
Band II	-	-	-	-	+24	+1,7/-3,7	-	-	+21	+2,7/-2,7
Band III	-	-	-	-	+24	+1,7/-3,7	-	-	+21	+2,7/-2,7
Band IV	-	-	-	-	+24	+1,7/-3,7	-	-	+21	+2,7/-2,7
Band V	-	-	-	-	+24	+1,7/-3,7	-	-	+21	+2,7/-2,7
Band VI	-	-	-	-	+24	+1,7/-3,7	-	-	+21	+2,7/-2,7
Band VII	-	-	-	-	+24	+1,7/-3,7	+23	+2,7/-2,7	+21	+2,7/-2,7
Band VIII	-	-	-	-	+24	+1,7/-3,7	+23	+2,7/-2,7	+21	+2,7/-2,7
Band IX	-	-	-	-	+24	+1,7/-3,7	-	-	+21	+2,7/-2,7
Band X	-	-	-	-	+24	+1,7/-3,7	-	-	+21	+2,7/-2,7
Band XI	-	-	-	-	+24	+1,7/-3,7	-	-	+21	+2,7/-2,7

NOTE: If the above Test Requirement differs from the Minimum Requirement then the Test Tolerance applied for this test is non-zero. The Test Tolerance for this test is defined in clause F.2 and the explanation of how the Minimum Requirement has been relaxed by the Test Tolerance is given in clause F.4.

5.2A Maximum Output Power with HS-DPCCH (Release 5 only)

5.2A.1 Definition and applicability

The maximum output power with HS-DPCCH and its tolerance are defined according to the Power Class of the UE.

The maximum output power with HS-DPCCH is a measure of the maximum power the UE can transmit when HS-DPCCH is fully or partially transmitted during a DPCCH timeslot. The measurement period shall be at least one timeslot.

The requirements and this test apply to all types of UTRA for the FDD UE that support HSDPA for Release 5.

5.2A.2 Minimum Requirements

The UE maximum output power with HS-DPCCH shall be within the value and tolerance specified in table 5.2A.1 when HS-DPCCH is fully or partially transmitted during a DPCCH timeslot. The maximum output power where HS-DPCCH is not transmitted shall be within the values and tolerance specified in table 5.2.1.

Table 5.2A.1: Maximum Output Powers with HS-DPCCH

Ratio of β_c to β_d for all values of β_{hs}	Power Class 3		Power Class 4	
	Power (dBm)	Tol (dB)	Power (dBm)	Tol (dB)
$1/15 \leq \beta_c/\beta_d \leq 12/15$	+24	+1/-3	+21	+2/-2
$13/15 \leq \beta_c/\beta_d \leq 15/8$	+23	+2/-3	+20	+3/-2
$15/7 \leq \beta_c/\beta_d \leq 15/0$	+22	+3/-3	+19	+4/-2

The normative reference for this requirement is TS 25.101 [1] clause 6.2.2.

5.2A.3 Test purpose

To verify that the error of the UE maximum output power with HS-DPCCH does not exceed the range prescribed by the maximum output power and tolerance in table 5.2A.1.

An excess maximum output power may interfere with other channels or other systems. A small maximum output power decreases the coverage area.

5.2A.4 Method of test

5.2A.4.1 Initial conditions

Test environment: normal, TL/VL, TL/VH, TH/VL, TH/VH; see clauses G.2.1 and G.2.2.

Frequencies to be tested: low range, mid range, high range; see clause G.2.4.

- 1) Connect the SS (node B emulator) to the UE antenna connector as shown in figure A.1.
- 2) The UL Reference Measurement Channel and the Fixed Reference Channels (FRC H-Set 1, QPSK version) are specified in Annex C.10.1 and C.8.1.1 with the beta values set according to table C.10.1.4.
- 3) An HSDPA call is set up according to TS 34.108 [3] clause 7.3.6. RF parameters are set up according to table E.5.1 and table E.5.10. Settings for the serving cell are defined in table 5.2A.1A.
- 4) Enter the UE into loopback test mode in the presence of HSDPA and start the loopback test.

See TS 34.108 [3] and TS 34.109 [4] for details regarding loopback test mode for HSDPA.

Table 5.2A.1A: Settings for the serving cell during the measurement of Maximum Output Power with HS-DPCCH

Parameter	Unit	Cell 1
Cell type		Serving cell
UTRA RF Channel Number		As defined in clause 5.2A.4.1
Qqualmin	dB	-24
Qrxlevmin	dBm	-115
UE_TXPWR_MAX_RACH	dBm	+21
I_{or} (see notes 1 and 2)	dBm/3.84 MHz	-86
NOTE 1: The power level is specified in terms of I_{or} instead of CPICH_RSCP because RSCP is a receiver measurement, whereas the SS can only set I_{or} .		
NOTE 2: The cell fulfils TS 25.304, 5.2.3.1.2.		

5.2A.4.2 Procedure

- 1) Send TRANSPORT CHANNEL RECONFIGURATION message to set the beta values according to table C.10.1.4 and the DPCH frame offset according the HS-DPCCH slot offset required for measurements.
- 2) Set and send continuously Up power control commands to the UE.
- 3) Start transmitting HSDPA Data.
- 4) Measure the mean power of the UE. The mean power shall be averaged over at least one timeslot.
- 5) Repeat the measurement for the different combinations of beta values as given in table C.10.1.4.

Specific Message Contents

All messages indicated above shall use the same content as described in the default message content in clause 9 of TS 34.108 [3], except the TRANSPORT CHANNEL RECONFIGURATION message which is defined in Annex I.

5.2A.5 Test requirements

The maximum output power with HS-DPCCH, derived in step 4), shall not exceed the range prescribed by the maximum output power and tolerance in table 5.2A.2. The maximum output power where HS-DPCCH is not transmitted shall not exceed the range prescribed in table 5.2.2.

The UL reference measurement channel for TX test will be set as defined in C.10.1 with the power ratio between HS-DPCCH, DPCCH and DPDCH being set to the values defined in table C.10.1.4.

Table 5.2A.2: Maximum Output Powers with HS-DPCCH for test

Ratio of β_c to β_d for all values of β_{hs}	Power Class 3		Power Class 4	
	Power (dBm)	Tol (dB)	Power (dBm)	Tol (dB)
$\beta_c/\beta_d = 2/15, 12/15$	+24	+1.7/-3.7	+21	+2.7/-2.7
$\beta_c/\beta_d = 15/8$	+23	+2.7/-3.7	+20	+3.7/-2.7
$\beta_c/\beta_d = 15/4$	+22	+3.7/-3.7	+19	+4.7/-2.7

Note: For the purpose of the test Δ_{ACK} , Δ_{NACK} and $\Delta_{CQI} = 30/15$ with $\beta_{hs} = 30/15 * \beta_c$.

NOTE: If the above Test Requirement differs from the Minimum Requirement then the Test Tolerance applied for this test is non-zero. The Test Tolerance for this test is defined in clause F.2 and the explanation of how the Minimum Requirement has been relaxed by the Test Tolerance is given in clause F.4.

5.2AA Maximum Output Power with HS-DPCCH (Release 6 and later)

5.2AA.1 Definition and applicability

The maximum output power with HS-DPCCH and its tolerance are defined according to the UE Maximum Power Reduction (MPR) for the nominal maximum output power.

The maximum output power with HS-DPCCH is a measure of the maximum power the UE can transmit when HS-DPCCH is fully or partially transmitted during a DPCCH timeslot. The measurement period shall be at least one timeslot.

The requirements and this test apply for Release 6 and later releases to all types of UTRA for the FDD UE that support HSDPA without E-DCH.

5.2AA.2 Minimum Requirements

The UE Maximum Power Reduction (MPR) for the nominal maximum output power shall be within the value and tolerance specified in table 5.2AA.1 for when the values of β_c , β_d , β_{hs} , β_{ec} and β_{ed} is fully or partially transmitted during a DPCCH timeslot.

Table 5.2AA.1: Maximum Output Power with HS-DPCCH and E-DCH

UE transmit channel configuration	CM (dB)	MPR (dB)
For all combinations of; DPDCH, DPCCH, HS-DPCCH, E-DPDCH and E-DPCCH	$0 \leq CM \leq 3.5$	MAX (CM-1, 0)
Note 1: CM = 1 for $\beta_c/\beta_d = 12/15$, $\beta_{hs}/\beta_c = 24/15$. For all other combinations of DPDCH, DPCCH, HS-DPCCH, E-DPDCH and E-DPCCH the MPR is based on the relative CM difference.		

Where Cubic Metric (CM) is based on the UE transmit channel configuration and is given by

$$CM = \text{CEIL} \{ [20 * \log_{10} ((v_{\text{norm}}^3)_{\text{rms}}) - 20 * \log_{10} ((v_{\text{norm_ref}}^3)_{\text{rms}})] / k, 0.5 \}$$

Where

- CEIL{ x, 0.5 } means rounding upwards to closest 0.5dB, i.e. $CM \in [0, 0.5, 1.0, 1.5, 2.0, 2.5, 3.0, 3.5]$

- k is 1.85 for signals where all channelisations codes meet the following criteria $C_{SF, N}$ where $N < SF/2$
- k is 1.56 for signals where any channelisations codes meet the following criteria $C_{SF, N}$ where $N \geq SF/2$
- v_{norm} is the normalized voltage waveform of the input signal
- v_{norm_ref} is the normalized voltage waveform of the reference signal (12.2 kbps AMR Speech) and $20 * \log_{10}((v_{norm_ref}^3)_{rms}) = 1.52$ dB

The normative reference for this requirement is TS 25.101 [1] clause 6.2.2.

5.2AA.3 Test purpose

To verify that the error of the UE maximum output power with HS-DPCCH does not exceed the range prescribed by the maximum output power and tolerance in table 5.2AA.2.

An excess maximum output power may interfere with other channels or other systems. A small maximum output power decreases the coverage area.

5.2AA.4 Method of test

5.2AA.4.1 Initial conditions

Test environment: normal, TL/VL, TL/VH, TH/VL, TH/VH; see clauses G.2.1 and G.2.2.

Frequencies to be tested: low range, mid range, high range; see clause G.2.4.

- 1) Connect the SS (node B emulator) to the UE antenna connector as shown in figure A.1.
- 2) The UL Reference Measurement Channel and the Fixed Reference Channels (FRC H-Set 1) are specified in Annex C.10.1 and C.8.1.1.
- 3) An HSDPA call is set up according to TS 34.108 [3] clause 7.3.6. RF parameters are set up according to table E.5.1 and table E.5.10. Settings for the serving cell are defined in table 5.2AA.1A.
- 4) Enter the UE into loopback test mode in the presence of HSDPA and start the loopback test.

See TS 34.108 [3] and TS 34.109 [4] for details regarding loopback test mode for HSDPA.

Table 5.2AA.1A: Settings for the serving cell during the measurement of Maximum Output Power with HS-DPCCH

Parameter	Unit	Cell 1
Cell type		Serving cell
UTRA RF Channel Number		As defined in clause 5.2AA.4.1
Qqualmin	dB	-24
Qrxlevmin	dBm	-115
UE_TXPWR_MAX_RACH	dBm	+21
\hat{I}_{or} (see notes 1 and 2)	dBm/3.84 MHz	-86
NOTE 1: The power level is specified in terms of \hat{I}_{or} instead of CPICH_RSCP because RSCP is a receiver measurement, whereas the SS can only set \hat{I}_{or} .		
NOTE 2: The cell fulfils TS 25.304, 5.2.3.1.2.		

5.2AA.4.2 Procedure

- 1) Send TRANSPORT CHANNEL RECONFIGURATION message to set the beta values according to table C.10.1.4 and the DPCH frame offset according to the HS-DPCCH slot offset required for measurements.
- 2) Set and send continuously Up power control commands to the UE.
- 3) Start transmitting HSDPA Data.
- 4) Measure the mean power of the UE. The mean power shall be averaged over at least one timeslot.

5) Repeat the measurement for the different combinations of beta values as given in table C.10.1.4.

Specific Message Contents

All messages indicated above shall use the same content as described in the default message content in clause 9 of TS 34.108 [3], except the TRANSPORT CHANNEL RECONFIGURATION message which is defined in Annex I.

5.2AA.5 Test requirements

The maximum output power with HS-DPCCH, derived in step 4), shall not exceed the range prescribed by the maximum output power and tolerance in table 5.2AA.2. The maximum output power where HS-DPCCH is not transmitted shall not exceed the range prescribed in table 5.2.2.

The UL reference measurement channel for TX test will be set as defined in C.10.1 with the power ratio between HS-DPCCH, DPCCH and DPDCH being set to the values defined in table C.10.1.4.

Table 5.2AA.2: Maximum Output Powers with HS-DPCCH for test

Sub-test in table C.10.1.4	Power Class 3		Power Class 4	
	Power (dBm)	Tol (dB)	Power (dBm)	Tol (dB)
1	+24	+1.7/-3.7	+21	+2.7/-2.7
2	+24	+1.7/-3.7	+21	+2.7/-2.7
3	+23.5	+2.2/-3.7	+20.5	+3.2/-2.7
4	+23.5	+2.2/-3.7	+20.5	+3.2/-2.7

NOTE: If the above Test Requirement differs from the Minimum Requirement then the Test Tolerance applied for this test is non-zero. The Test Tolerance for this test is defined in clause F.2 and the explanation of how the Minimum Requirement has been relaxed by the Test Tolerance is given in clause F.4.

5.2B Maximum Output Power with HS-DPCCH and E-DCH

5.2B.1 Definition and applicability

The maximum output power with HS-DPCCH and E-DCH and its tolerance are defined according to the UE Maximum Power Reduction (MPR) for the nominal maximum output power.

The maximum output power with HS-DPCCH and E-DCH is a measure of the maximum power the UE can transmit when HS-DPCCH and E-DCH is fully or partially transmitted during a DPCCH timeslot. The measurement period shall be at least one timeslot.

The requirements and this test apply for Release 6 and later releases to all types of UTRA for the FDD UE that support HSDPA and E-DCH.

5.2B.2 Minimum Requirements

The UE Maximum Power Reduction (MPR) for the nominal maximum output power shall be within the value and tolerance specified in table 5.2B.1 for when the values of β_c , β_d , β_{hs} , β_{ec} and β_{ed} is fully or partially transmitted during a DPCCH timeslot.

Table 5.2B.1: Maximum Output Power with HS-DPCCH and E-DCH

UE transmit channel configuration	CM (dB)	MPR (dB)
For all combinations of; DPDCH, DPCCH, HS-DPCCH, E-DPCCH and E-DPCCH	$0 \leq CM \leq 3.5$	MAX (CM-1, 0)
Note 1: CM = 1 for $\beta_c/\beta_d = 12/15$, $\beta_{hs}/\beta_{ec} = 24/15$. For all other combinations of DPDCH, DPCCH, HS-DPCCH, E-DPCCH and E-DPCCH the MPR is based on the relative CM difference.		

Where Cubic Metric (CM) is based on the UE transmit channel configuration and is given by

$$CM = \text{CEIL} \{ [20 * \log_{10} ((v_{\text{norm}}^3)_{\text{rms}}) - 20 * \log_{10} ((v_{\text{norm_ref}}^3)_{\text{rms}})] / k, 0.5 \}$$

Where

- CEIL{ x, 0.5 } means rounding upwards to closest 0.5dB, i.e. $CM \in [0, 0.5, 1.0, 1.5, 2.0, 2.5, 3.0, 3.5]$
- k is 1.85 for signals where all channelisations codes meet the following criteria $C_{SF, N}$ where $N < SF/2$
- k is 1.56 for signals where any channelisations codes meet the following criteria $C_{SF, N}$ where $N \geq SF/2$
- v_{norm} is the normalized voltage waveform of the input signal
- v_{norm_ref} is the normalized voltage waveform of the reference signal (12.2 kbps AMR Speech) and $20 * \log_{10}((v_{norm_ref}^3)_{rms}) = 1.52$ dB

The normative reference for this requirement is TS 25.101 [1] clause 6.2.2.

5.2B.3 Test purpose

To verify that the error of the UE maximum output power with HS-DPCCH and E-DCH does not exceed the range prescribed by the maximum output power and tolerance in table 5.2B.5.

An excess maximum output power may interfere with other channels or other systems. A small maximum output power decreases the coverage area.

5.2B.4 Method of test

5.2B.4.1 Initial conditions

Test environment: normal, TL/VL, TL/VH, TH/VL, TH/VH; see clauses G.2.1 and G.2.2.

Frequencies to be tested: low range, mid range, high range; see clause G.2.4.

- 1) Connect the SS (node B emulator) to the UE antenna connector as shown in figure A.1.
- 2) The UL Reference Measurement Channel and the Fixed Reference Channels (FRC H-Set 1, QPSK) are specified in Annex C.11.1 and C.8.1.1.
- 3) An E-DCH call is set up according to TS 34.108 [3] 7.3.9 with the following exceptions in the RADIO BEARER SETUP messages. These exceptions allow the beta values to be set according to table C.11.1.3 and each UL physical channel to be at constant power during the measurement. RF parameters are set up according to table E.5A.1. Settings for the serving cell are defined in table 5.2B.4A.
- 4) Enter the UE into loopback test mode 1 looping back both the 12.2kbps RMC and HSDPA to E-DCH, and start the loopback test.

See TS 34.109 [4] clauses 5.3.2.3 and 5.3.2.6 for details regarding loopback test mode for HSDPA and E-DCH.

Table 5.2B.1A Contents of RADIO BEARER SETUP message: AM or UM (Test Loop Mode1)

Information Element	Value/Remark
UL Transport channel information for all transport channels <ul style="list-style-type: none"> - 2bit CTFC - Power offset Information - CHOICE Gain Factors - CHOICE mode - Gain factor β_c - Gain factor β_d 	3 Signalled Gain Factors FDD Value used in test: see Table C.11.1.3 Value used in test: see Table C.11.1.3
CHOICE channel requirement <ul style="list-style-type: none"> - Power Control Algorithm 	Uplink DPCH info Algorithm2
Note: All other 2 bit CTFC values use computed gain factors as in the default message	

Table 5.2B.2: Contents of RADIO BEARER SETUP message: AM or UM (E-DCH and HSDPA) for Sub-tests 1,2,4,5

Information Element	Value/Remark
E-DCH info	Uplink DPCH info
- E-DPDCH info	
- Reference E-TFCIs	5 E-TFCIs
- Reference E-TFCI	11
- Reference E-TFCI PO	4
- Reference E-TFCI	67
- Reference E-TFCI PO	18
- Reference E-TFCI	71
- Reference E-TFCI PO	23
- Reference E-TFCI	75
- Reference E-TFCI PO	26
- Reference E-TFCI	81
- Reference E-TFCI PO	27

Table 5.2B.3: Contents of RADIO BEARER SETUP message: AM or UM (E-DCH and HSDPA) for Sub-test 3

Information Element	Value/Remark
E-DCH info	Uplink DPCH info
- E-DPDCH info	
- Reference E-TFCIs	2 E-TFCIs
- Reference E-TFCI	11
- Reference E-TFCI PO	4
- Reference E-TFCI	92
- Reference E-TFCI PO	18

Table 5.2B.4 Contents of RADIO BEARER SETUP message: AM or UM (E-DCH and HSDPA)

Information Element	Value/Remark
CHOICE channel requirement	Uplink DPCH info
- Power Control Algorithm	Algorithm2
- Δ_{ACK}	Value used in test: see Table C.11.1.3
- Δ_{NACK}	Value used in test: see Table C.11.1.3
- Ack-Nack repetition factor	3 (required for continuous HS-DPCCH signal)
E-DCH info	
- E-DPCCH/DPCCH power offset	Value used in test: see Table C.11.1.3
Downlink HS-PDSCH Information	
- Measurement Feedback Info	
- CQI Feedback cycle, k	4 ms
- CQI repetition factor	2 (required for continuous HS-DPCCH signal)
- Δ_{CQI}	Value used in test: see Table C.11.1.3

Table 5.2B.4A: Settings for the serving cell during the measurement of Maximum Output Power with HS-DPCCH and E-DCH

Parameter	Unit	Cell 1
Cell type		Serving cell
UTRA RF Channel Number		As defined in clause 5.2B.4.1
Qqualmin	dB	-24
Qrxlevmin	dBm	-115
UE_TXPWR_MAX_RACH	dBm	+21
\hat{I}_{or} (see notes 1 and 2)	dBm/3.84 MHz	-86
NOTE 1: The power level is specified in terms of \hat{I}_{or} instead of CPICH_RSCP because RSCP is a receiver measurement, whereas the SS can only set \hat{I}_{or} .		
NOTE 2: The cell fulfils TS 25.304, 5.2.3.1.2.		

5.2B.4.2 Procedure

- 1) Set the Absolute Grant according to Table C.11.1.3.
- 2) The SS starts transmitting HSDPA and the UE loops the received data back on E-DCH.
- 3) Set the UE power to be at least 6dB lower than the maximum output power. Wait 150ms.
- 4) Send power control bits to give one TPC_cmd = +1 command to the UE.
- 5) The SS checks the received E-TFCI for 150 ms. If UE does not send any decreased E-TFCI within the 150ms then go back to step (4) otherwise proceed to step 6).
- 6) Send power control bits to give one TPC_cmd = -1 command to the UE.
- 7) The SS checks the received E-TFCI for 150 ms. If UE sends any decreased E-TFCI within the 150ms, then send new power control bits to give another TPC_cmd = -1 command to the UE and wait 150ms.
- 8) Confirm that the E-TFCI transmitted by the UE is equal to the target E-TFCI in Table C.11.1.3. If the E-TFCI transmitted by the UE is not equal to the target E-TFCI, then fail the UE.
- 9) Measure the mean power of the UE. The mean power shall be averaged over at least one timeslot.
- 10) Repeat the measurement for the different combinations of beta values as given in table C.11.1.3.

5.2B.5 Test requirements

The maximum output power with HS-DPCCH and E-DCH, derived in step 9), shall not exceed the range prescribed by the maximum output power and tolerance in table 5.2B.5. Note:

The UL reference measurement channel for TX test will be set as defined in C.11.1 with the power ratio between HS-DPCCH, DPCCH, DPDCH, E-DPCCH and E-DPDCH being set to the values defined in table C.11.1.3.

Table 5.2B.5: Maximum Output Powers with HS-DPCCH and E-DCH for test

Sub-test in table C.11.1.3	Power Class 3		Power Class 4	
	Power (dBm)	Tol (dB)	Power (dBm)	Tol (dB)
1	+24	+1.7/-5.2	+21	+2.7/-4.2
2	+22	+3.7/-5.2	+19	+4.7/-4.2
3	+23	+2.7/-5.2	+20	+3.7/-4.2
4	+22	+3.7/-5.2	+19	+4.7/-4.2
5	+24	+1.7/-5.2	+21	+2.7/-4.2

NOTE1: If the above Test Requirement differs from the Minimum Requirement then the Test Tolerance applied for this test is non-zero. The Test Tolerance for this test is defined in clause F.2 and the explanation of how the Minimum Requirement has been relaxed by the Test Tolerance is given in clause F.4.

NOTE2: The test procedure will result in a power slightly below the maximum, and therefore the lower limits in Table 5.2B.5 are made lower by 1.5 dB.

5.2C UE relative code domain power accuracy

5.2C.1 Definition and applicability

The UE Relative code domain power accuracy is a measure of the ability of the UE to correctly set the level of individual code powers relative to the total power of all active codes. The measure of accuracy is the difference between two dB ratios:

$$\text{UE Relative CDP accuracy} = (\text{Measured CDP ratio}) - (\text{Nominal CDP ratio})$$

where

$$\text{Measured CDP ratio} = 10 \cdot \log((\text{Measured code power}) / (\text{Measured total power of all active codes}))$$

$$\text{Nominal CDP ratio} = 10 \cdot \log((\text{Nominal CDP}) / (\text{Sum of all nominal CDPs}))$$

The nominal CDP of a code is relative to the total of all codes and is derived from beta factors. The sum of all nominal CDPs will equal 1 by definition.

NOTE: The above definition of UE relative CDP accuracy is independent of variations in the actual total power of the signal and of noise in the signal that falls on inactive codes.

The requirements apply for Release 6 and later releases to all types of UTRA for the FDD UE. This test applies only to UE that support HSDPA.

5.2C.2 Minimum Requirements

The required accuracy of the UE relative CDP is given in table 5.2C.1. The UE relative CDP accuracy shall be maintained over the period during which the total of all active code powers remains unchanged or one timeslot, whichever is the longer.

Table 5.2C.1: UE Relative CDP accuracy

Nominal CDP ratio	Accuracy (dB)
≥ -10 dB	±1.5
-10 dB to ≥ -15 dB	±2.0
-15 dB to ≥ -20 dB	±2.5

The normative reference for this requirement is TS 25.101 [1] clause 6.2.3.

5.2C.3 Test purpose

To verify that the UE relative code domain power accuracy meets the requirements given in table 5.2C.4.

5.2C.4 Method of test

5.2C.4.1 Initial conditions

Test environment: normal; see clauses G.2.1 and G.2.2.

Frequencies to be tested: mid range; see clause G.2.4.

- 1) Connect the SS (node B emulator) to the UE antenna connector as shown in figure A.1.
- 2) The UL Reference Measurement Channel and the Fixed Reference Channels (FRC H-Set 1, QPSK version) are specified in Annex C.10.1 and C.8.1.1.
- 3) An HSDPA call is set up according to TS 34.108 [3] clause 7.3.6. RF parameters are set up according to table E.5.1 and table E.5.10. Settings for the serving cell are defined in table 5.2C.2.
- 4) Enter the UE into loopback test mode 1 in the presence of HSDPA and start the loopback test.

Table 5.2C.2: Settings for the serving cell during the measurement of HS-DPCCH

Parameter	Unit	Cell 1
Cell type		Serving cell
UTRA RF Channel Number		As defined in clause 5.2C.4.1
Qqualmin	dB	-24
Qrxlevmin	dBm	-115
UE_TXPWR_MAX_RACH	dBm	+21
\hat{I}_{or} (see notes 1 and 2)	dBm/3.84 MHz	-86
NOTE 1: The power level is specified in terms of \hat{I}_{or} instead of CPICH_RSCP because RSCP is a receiver measurement, whereas the SS can only set \hat{I}_{or} .		
NOTE 2: The cell fulfils TS 25.304, 5.2.3.1.2.		

See TS 34.108 [3] and TS 34.109 [4] for details regarding loopback test mode for HSDPA.

5.2C.4.2 Procedure

- 1) Send the TRANSPORT CHANNEL RECONFIGURATION message to set the beta values defined in table C.10.1.4 subtest 1 and the DPCH frame offset according the HS-DPCCH half slot offset required for measurements. This will create a signal with a repeat pattern of 12ms. The Uplink DPCH Power Control Info shall specify the Power Control Algorithm as algorithm 2 for interpreting TPC commands.
- 2) Generate suitable TPC commands from the SS to set the output power of the UE, when the HS-DPCCH is not transmitted, measured at the UE antenna connector, to be in the range 0 dBm \pm 2dB. This is a nominal setting and not part of the test requirements.
- 3) Send alternating "0" and "1" TPC commands in the downlink so as to satisfy the condition of obtaining TPC_cmd = 0.
- 4) Start transmitting HSDPA Data.
- 5) Figure 5.2C.1 shows the 12ms cycle created when using the TRANSPORT CHANNEL RECONFIGURATION message from Annex I with the test specific message content defined below and with TPC_cmd=0. Measure the relative code domain power of each active code at the measurement points specified in figure 5.2C.1. Each measurement is over a half slot period. Point 1 is the half slot prior to the ACK/NACK. Point 2 is the first half slot of the ACK/NACK, point 3 is the first half slot of the CQI and point 4 is the first half slot after the CQI. The 25us transient periods at the end of each half slot period shall not be included. The nominal UE relative code domain power for each active code at each point is defined in table 5.2C.3. The required accuracy which is the difference between the expected and measured code domain power shall meet the test requirements given in table 5.2C.4.

Specific Message Contents

All messages indicated above shall use the same content as described in the default message content in clause 9 of TS 34.108 [3], except the TRANSPORT CHANNEL RECONFIGURATION message which is defined in Annex I. The test specific content for the TRANSPORT CHANNEL RECONFIGURATION message is as follows:

Information Element	Value/remark
- Ack-Nack repetition factor	1
- CQI repetition factor	1

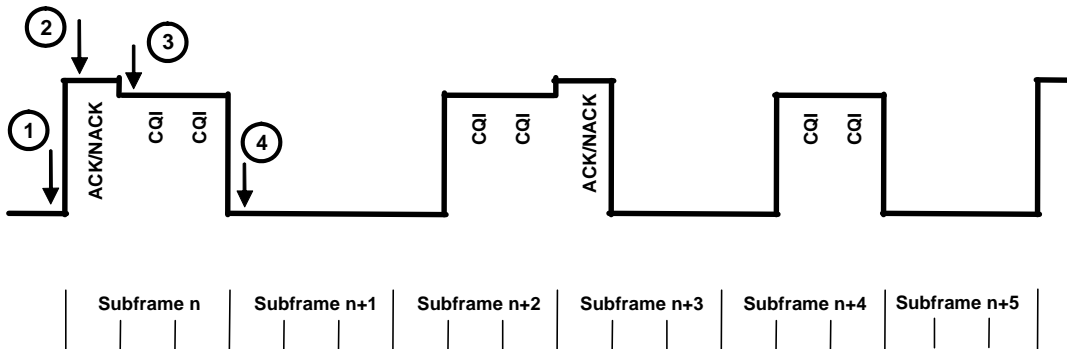

Figure 5.2C.1: Transmit power profile showing measurement points

5.2C.5 Test requirements

For the expected relative code domain power ratios given in table 5.2C.3 the UE shall meet the UE relative code domain power accuracy test requirements given in Table 5.2C.4.

Table 5.2C.3: UE relative code domain power nominal ratios

Sub-test in table C.10.1.4	Measurement point	Expected relative code domain power in dB		
		DPCCH	DPDCH	HS-DPCCH
1	1	-17.6	-0.08	OFF
	2	-17.9	-0.4	-11.8
	3	-17.8	-0.3	-13.7
	4	-17.6	-0.08	OFF
2	1	-4.1	-2.1	OFF
	2	-8.2	-6.2	-2.1
	3	-7.1	-5.2	-3
	4	-4.1	-2.1	OFF
3	1	-1.1	-6.5	OFF
	2	-7.2	-12.7	-1.2
	3	-5.8	-11.3	-1.8
	4	-1.1	-6.5	OFF
4	1	-0.3	-11.8	OFF
	2	-7.1	-18.5	-1
	3	-5.6	-17.1	-1.5
	4	-0.3	-11.8	OFF

Table 5.2C.4: UE relative code domain power accuracy test requirements

Nominal CDP ratio	Accuracy (dB)
≥ -10 dB	±1.7
-10 dB to ≥ -15 dB	±2.3
-15 dB to ≥ -20 dB	±2.9

NOTE: If the above Test Requirement differs from the Minimum Requirement then the Test Tolerance applied for this test is non-zero. The Test Tolerance for this test is defined in clause F.2 and the explanation of how the Minimum Requirement has been relaxed by the Test Tolerance is given in clause F.4.

5.2D UE Relative Code Domain Power Accuracy for HS-DPCCH and E-DCH

5.2D.1 Definition and applicability

The UE Relative code domain power accuracy is a measure of the ability of the UE to correctly set the level of individual code powers relative to the total power of all active codes. The measure of accuracy is the difference between two dB ratios:

$$\text{UE Relative CDP accuracy} = (\text{Measured CDP ratio}) - (\text{Nominal CDP ratio})$$

where

$$\text{Measured CDP ratio} = 10 \cdot \log((\text{Measured code power}) / (\text{Measured total power of all active codes}))$$

$$\text{Nominal CDP ratio} = 10 \cdot \log((\text{Nominal CDP}) / (\text{Sum of all nominal CDPs}))$$

The nominal CDP of a code is relative to the total of all codes and is derived from beta factors. The sum of all nominal CDPs will equal 1 by definition.

NOTE: The above definition of UE relative CDP accuracy is independent of variations in the actual total power of the signal and of noise in the signal that falls on inactive codes.

The requirements apply for Release 6 and later releases to all types of UTRA for the FDD UE. This test applies only to UE that support HSDPA and E-DCH. This test is in addition to the test for HSDPA only in 5.2C.

5.2D.2 Minimum Requirements

The required accuracy of the UE relative CDP is given in table 5.2D.1. The UE relative CDP accuracy shall be maintained over the period during which the total of all active code powers remains unchanged or one timeslot, whichever is the longer.

Table 5.2D.1: UE Relative CDP accuracy

Nominal CDP ratio	Accuracy (dB)
≥ -10 dB	± 1.5
-10 dB to ≥ -15 dB	± 2.0
-15 dB to ≥ -20 dB	± 2.5

The normative reference for this requirement is TS 25.101 [1] clause 6.2.3.

5.2D.3 Test purpose

To verify that the UE relative code domain power accuracy meets the requirements given in table 5.2D.8.

5.2D.4 Method of test

5.2D.4.1 Initial conditions

Test environment: normal; see clauses G.2.1 and G.2.2.

Frequencies to be tested: mid range; see clause G.2.4.

- 1) Connect the SS (node B emulator) to the UE antenna connector as shown in figure A.1.
- 2) The UL Reference Measurement Channel and the Fixed Reference Channels (FRC H-Set 1, QPSK version) are specified in Annex C.11.1 and C.8.1.1.
- 3) An E-DCH call is set up according to TS 34.108 [3] 7.3.9 with the following exceptions in the RADIO BEARER SETUP messages. These exceptions allow the beta values to be set according to table C.11.1.3 and each UL physical channel to be at constant power at the start of the measurement. RF parameters are set up according to table E.5A.1. Settings for the serving cell are defined in table 5.2D.6.

- 4) Enter the UE into loopback test mode 1 looping back both the 12.2kbps RMC and HSDPA to E-DCH, and start the loopback test.

See TS 34.109 [4] clauses 5.3.2.3 and 5.3.2.6 for details regarding loopback test mode for HSDPA and E-DCH.

Table 5.2D.2 Contents of RADIO BEARER SETUP message: AM or UM (Test Loop Mode1)

Information Element	Value/Remark
UL Transport channel information for all transport channels	
- 2bit CTFC	3
- Power offset Information	
- CHOICE Gain Factors	Signalled Gain Factors
- CHOICE mode	FDD
- Gain factor β_c	Value used in test: see Table C.11.1.3
- Gain factor β_d	Value used in test: see Table C.11.1.3
Note: All other 2 bit CTFC values use computed gain factors as in the default message	

Table 5.2D.3: Contents of RADIO BEARER SETUP message: AM or UM (E-DCH and HSDPA) for Subtests 1,2,4

Information Element	Value/Remark
E-DCH info	Uplink DPCH info
- E-DPDCH info	
- Reference E-TFCIs	5 E-TFCIs
- Reference E-TFCI	11
- Reference E-TFCI PO	4
- Reference E-TFCI	67
- Reference E-TFCI PO	18
- Reference E-TFCI	71
- Reference E-TFCI PO	23
- Reference E-TFCI	75
- Reference E-TFCI PO	26
- Reference E-TFCI	81
- Reference E-TFCI PO	27

Table 5.2D.4: Contents of RADIO BEARER SETUP message: AM or UM (E-DCH and HSDPA) for Subtest 3

Information Element	Value/Remark
E-DCH info	Uplink DPCH info
- E-DPDCH info	
- Reference E-TFCIs	2 E-TFCIs
- Reference E-TFCI	11
- Reference E-TFCI PO	4
- Reference E-TFCI	92
- Reference E-TFCI PO	18

Table 5.2D.5 Contents of RADIO BEARER SETUP message: AM or UM (E-DCH and HSDPA)

Information Element	Value/Remark
CHOICE channel requirement - Power Control Algorithm - Δ_{ACK}	Uplink DPCH info Algorithm2 Value used in test: see Table C.11.1.3
- Δ_{NACK}	Value used in test: see Table C.11.1.3
- Ack-Nack repetition factor	3 (required for continuous HS-DPCCH signal)
E-DCH info	
- E-DPCCH/DPCCH power offset	Value used in test: see Table C.11.1.3
Downlink HS-PDSCH Information	
- Measurement Feedback Info	
- CQI Feedback cycle, k	4 ms
- CQI repetition factor	2 (required for continuous HS-DPCCH signal)
- Δ_{CQI}	Value used in test: see Table C.11.1.3

Table 5.2D.6: Settings for the serving cell during the measurement of UE Relative Code Domain Power Accuracy with HS-DPCCH and E-DCH

Parameter	Unit	Cell 1
Cell type		Serving cell
UTRA RF Channel Number		As defined in clause 5.2B.4.1
Qqualmin	dB	-24
Qrxlevmin	dBm	-115
UE_TXPWR_MAX_RACH	dBm	+21
I_{or} (see notes 1 and 2)	dBm/3.84 MHz	-86
NOTE 1: The power level is specified in terms of I_{or} instead of CPICH_RSCP because RSCP is a receiver measurement, whereas the SS can only set I_{or} .		
NOTE 2: The cell fulfils TS 25.304, 5.2.3.1.2.		

5.2D.4.2 Procedure

- 1) Set UE to maximum output power according to 5.2.B.4.2 steps 1 to 8.
- 2) Send alternating “0” and “1” TPC commands in the downlink so as to satisfy the condition of obtaining $TPC_cmd = 0$.
- 3) Send Absolute Grants in a repeating pattern starting with the value according to Table C.11.1.3 and alternating between this value and an Absolute Grant Index of Zero_Grant. This will generate a repeating pattern on the E-DPDCH(s) with a level corresponding to the sending of Scheduling Information every other 10ms E-DCH TTI as shown in Figure 5.2D.1.

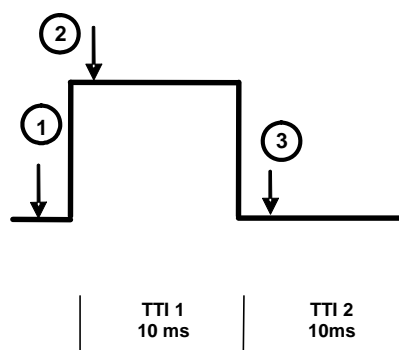

Figure 5.2D.1: Transmit power profile showing measurement points

- 4) Measure the relative code domain power of each active code at the measurement points specified in Figure 5.2D.1. Each measurement is made over one timeslot. Measurement point 1 is the last timeslot before TTI1. Measurement point 2 is the first timeslot of TTI1 and measurement point 3 is the first timeslot of TTI2. The 25us transient periods at the ends of each measured timeslot shall not be included. The nominal UE relative code domain power for each active code at each point is defined in table 5.2D.7. The required accuracy which is the difference between the expected and measured code domain power shall meet the test requirements given in table 5.2D.8.
- 5) Repeat steps 1 through 4 for the other combinations of beta values for sub-tests 1, 2, 3, and 4 as given in Table C.11.1.3.

5.2D.5 Test requirements

For all UE relative code domain power nominal ratios given in table 5.2D.7 ≥ -20 dB the UE shall meet the UE relative code domain power accuracy test requirements given in Table 5.2D.8.

Table 5.2D.7: UE relative code domain power nominal ratios

Sub-Test in Table C.11.1.3	Measurement Point	Expected Relative Code Domain Power in dB					
		DPCCH	DPDCH	HS-DPCCH	E-DPCCH	E-DPDCH1	E-DPDCH2
1	1	-9.3	-6.6	-3.3	-7.3	-18.9	OFF
	2	-18.5	-15.8	-12.5	-16.5	-0.5	OFF
	3	-9.3	-6.6	-3.3	-7.3	-18.9	OFF
2	1	-11.9	-3.9	-5.8	-5.8	-21.4	OFF
	2	-14.0	-6.0	-8.0	-8.0	-4.1	OFF
	3	-11.9	-3.9	-5.8	-5.8	-21.4	OFF
3	1	-9.8	-14.2	-3.7	-3.7	-19.3	OFF
	2	-14.6	-19.1	-8.6	-8.6	-4.7	-4.7
	3	-9.8	-14.2	-3.7	-3.7	-19.3	OFF
4	1	-17.9	-0.4	-11.9	-17.9	-27.5	OFF
	2	-19.7	-2.2	-13.7	-19.7	-4.7	OFF
	3	-17.9	-0.4	-11.9	-17.9	-27.5	OFF

Table 5.2D.8: UE relative code domain power accuracy test requirements

Nominal CDP ratio	Accuracy (dB)
≥ -10 dB	± 1.7
-10 dB to ≥ -15 dB	± 2.3
-15 dB to ≥ -20 dB	± 2.9

NOTE: If the above Test Requirement differs from the Minimum Requirement then the Test Tolerance applied for this test is non-zero. The Test Tolerance for this test is defined in clause F.2 and the explanation of how the Minimum Requirement has been relaxed by the Test Tolerance is given in clause F.4.

5.3 Frequency Error

5.3.1 Definition and applicability

The frequency error is the difference between the RF modulated carrier frequency transmitted from the UE and the assigned frequency. The UE transmitter tracks to the RF carrier frequency received from the Node B. These signals will have an apparent error due to Node B frequency error and Doppler shift. In the later case, signals from the Node B must be averaged over sufficient time that errors due to noise or interference are allowed for within the minimum requirements specified in 5.3.2.

The UE shall use the same frequency source for both RF frequency generation and the chip clock.

The requirements and this test apply to all types of UTRA for the FDD UE.

5.3.2 Minimum Requirements

The UE modulated carrier frequency shall be accurate to within $\pm 0,1$ ppm observed over a period of one timeslot compared to the carrier frequency received from the Node B.

The normative reference for this requirement is TS 25.101 [1] clause 6.3.

5.3.3 Test purpose

To verify that the UE carrier frequency error does not exceed $\pm 0,1$ ppm. This requirement is tested with the UE receiver at the reference sensitivity.

An excess error of the carrier frequency increases the transmission errors in the up link own channel.

This test verifies the ability of the receiver to derive correct frequency information for the transmitter, when locked to the DL carrier frequency.

5.3.4 Method of test

5.3.4.1 Initial conditions

Test environment for UE without vibration sensitive components: normal, TL/VL, TL/VH, TH/VL, TH/VH; see clauses G.2.1 and G.2.2.

Test environment for other UE: normal, TL/VL, TL/VH, TH/VL, TH/VH, vibration; see clauses G.2.1, G.2.2 and G.2.3.

NOTE: "UE without vibration sensitive components" is declared in table A.12 of [32].

Frequencies to be tested: low range, mid range, high range; see clause G.2.4.

- 1) Connect the SS to the UE antenna connector as shown in figure A.1.
- 2) A call is set up according to the Generic call setup procedure in TS34.108 [3] sub clause 7.3.2, and RF parameters (DPCH_Ec and \hat{I}_{or}) are set up according to table 6.2.2. The relative power level of other downlink physical channels to the DPCH_Ec are set up according to clause E.3.2.
- 3) Enter the UE into loopback test mode and start the loopback test.

See TS 34.108 [3] and TS 34.109 [4] for details regarding generic call setup procedure and loopback test.

5.3.4.2 Procedure

- 1) Set and send continuously Up power control commands to the UE until the UE reaches its maximum output power.
- 2) Measure the frequency error delta f, using the Global In-Channel-Tx-test (annex B).

5.3.5 Test Requirements

For all measurements, the frequency error, derived in step 2), shall not exceed $\pm(0,1 \text{ ppm} + 10 \text{ Hz})$.

NOTE: If the above Test Requirement differs from the Minimum Requirement then the Test Tolerance applied for this test is non-zero. The Test Tolerance for this test is defined in clause F.2 and the explanation of how the Minimum Requirement has been relaxed by the Test Tolerance is given in clause F.4.

5.4 Output Power Dynamics in the Uplink

Power control is used to limit the interference level.

5.4.1 Open Loop Power Control in the Uplink

5.4.1.1 Definition and applicability

Open loop power control in the uplink is the ability of the UE transmitter to set its output power to a specific value. This function is used for PRACH transmission and based on the information from Node B using BCCH and the downlink

received signal power level of the CPICH. The information from Node B includes transmission power of CPICH and uplink interference power level.

The requirements and this test apply to all types of UTRA for the FDD UE.

5.4.1.2 Minimum requirements

The UE open loop power is defined as the mean power in a timeslot or ON power duration, whichever is available.

The UE open loop power control tolerance is given in table 5.4.1.1.

Table 5.4.1.1: Open loop power control tolerance

Normal conditions	±9 dB
Extreme conditions	±12 dB

The reference for this requirement is TS 25.101 [1] clause 6.4.1.

5.4.1.3 Test purpose

The power measured by the UE of the received signal and the signalled BCCH information are used by the UE to control the power of the UE transmitted signal with the target to transmit at the lowest power acceptable for proper communication.

The test stresses the ability of the receiver to measure the received power correctly over the receiver dynamic range.

The test purpose is to verify that the UE open loop power control tolerance does not exceed the described value shown in table 5.4.1.1.

An excess error of the open loop power control decreases the system capacity.

5.4.1.4 Method of test

5.4.1.4.1 Initial conditions

Test environment: normal, TL/VL, TL/VH, TH/VL, TH/VH; see clauses G.2.1 and G.2.2.

Frequencies to be tested: low range, mid range, high range; see clause G.2.4.

- 1) Connect the SS to the UE antenna connector as shown in figure A.1.
- 2) Channel conditions are initially set up with received CPICH_RSCP >-85 dBm. The relative power level of downlink physical channels to Ior are set up according to clause E.2.1. The parameter settings of the cell are set up according to Table 5.4.1.1a.
- 3) Switch on the phone.
- 4) After the UE has performed registration and entered idle mode, \hat{I}_{or} is set up according to table 5.4.1.2. The relative power level of downlink physical channels to Ior are set up according to clause E.2.1
- 5) A call is set up according to the Generic call setup procedure in [3] clause 7.3.1 with channel conditions according the test parameters in table 5.4.1.3, The RACH procedure within the call setup is used for the test.

Table 5.4.1.1a: Settings for the serving cell

Parameter	Unit	Cell 1
Cell type		Serving cell
UTRA RF Channel Number		Channel 1
Qqualmin	dB	-24
Qrxlevmin	dBm	-115
UE_TXPWR_MAX_RACH	dBm	21
Preamble Retrans Max		1

Table 5.4.1.2: Test parameters for Open Loop Power Control (UE)

Parameter	Level / Status	Unit
\hat{I}_{or}	See table 5.4.1.3	dBm / 3,84 MHz

Table 5.4.1.3: Test parameters for Open Loop Power Control (SS)

Parameter	RX Upper dynamic end	RX-middle	RX-Sensitivity level
\hat{I}_{or} (note 3)	-25,0 dBm / 3,84 MHz	-65,7 dBm / 3,84 MHz	<REF \hat{I}_{or} > dBm / 3,84 MHz
CPICH_RSCP (notes 3 and 4)	-28,9 dBm	-69,6 dBm	<REF \hat{I}_{or} > +CPICH_Ec / Ior
Primary CPICH DL TX power	+19 dBm	+28 dBm	+19 dBm
Simulated path loss = Primary CPICH DL TX power – CPICH_RSCP	+47.9 dB	+97.6 dB	Band I, IV, VI, X: +128.9 dB Band II, V, VII, XI: +126.9 dB Band III, VIII: +125.9 dB Band IX: +127.9 dB
UL interference	-75 dBm	-101 dBm	Band I, IV, VI, X: -110 dBm
			Band II, V, VII, XI: -108 dBm
			Band III, VIII: -107 dBm
			Band IX: -109 dBm
Constant Value	-10 dB	-10 dB	-10 dB
Expected nominal UE TX power (note 5)	-37.1 dBm	-13.4 dBm	+8.9 dBm (note 2)
NOTE 1: While the SS transmit power shall cover the receiver input dynamic range, the logical parameters: Primary CPICH DL TX power, UL interference, Constant Value are chosen to achieve a UE TX power, located within the TX output power dynamic range of a class 4 UE.			
NOTE 2: Nominal TX output power <9 dBm allows to check the open loop power algorithm within the entire tolerance range (9 dBm ± 12 dB; 9 dBm + 12 dB = 21 dBm = max power class 4).			
NOTE 3: <REF \hat{I}_{or} > is specified in Table 6.2.2, and CPICH_Ec / Ior is specified in Table E.2.2. The power level of S-CCPCH should be defined because S-CCPCH is transmitted during Preamble RACH transmission period. The power level of S-CCPCH is set to -5.3 dB relative to \hat{I}_{or} .			
NOTE 4: The purpose of this parameter is to calculate the Expected nominal UE TX power.			
NOTE 5: The Expected nominal UE TX power is calculated by using the equation in the clause 8.5.7 Open Loop Power Control of TS 25.331 [8].			

5.4.1.4.2 Procedure

- 1) Set the TX output level of the SS to obtain \hat{I}_{or} at the UE antenna connector. \hat{I}_{or} shall be according to table 5.4.1.3 (-25 dBm / 3,84 MHz).
- 2) Measure the first RACH preamble mean power of the UE.
- 3) Repeat the above measurement for all SS levels in table 5.4.1.3.

5.4.1.5 Test requirements

The deviation with respect to the Expected nominal UE TX power (table 5.4.1.3), derived in step 2), shall not exceed the prescribed tolerance in table 5.4.1.4.

Table 5.4.1.4: Open loop power control tolerance

Normal conditions	±10 dB
Extreme conditions	±13 dB

NOTE: If the above Test Requirement differs from the Minimum Requirement then the Test Tolerance applied for this test is non-zero. The Test Tolerance for this test is defined in clause F.2 and the explanation of how the Minimum Requirement has been relaxed by the Test Tolerance is given in clause F.4.

5.4.2 Inner Loop Power Control in the Uplink

5.4.2.1 Definition and applicability

Inner loop power control in the uplink is the ability of the UE transmitter to adjust its output power in accordance with one or more TPC commands received in the downlink.

The power control step is the change in the UE transmitter output power in response to a single TPC command, TPC_cmd, derived at the UE.

This clause does not cover all the requirements of compressed mode or soft handover.

The requirements and this test apply to all types of UTRA for the FDD UE.

5.4.2.2 Minimum requirements

The UE transmitter shall have the capability of changing the output power with a step size of 1 dB, 2 dB and 3 dB according to the value of Δ_{TPC} or $\Delta_{\text{RP-TPC}}$, in the slot immediately after the TPC_cmd can be derived.

- The transmitter output power step due to inner loop power control shall be within the range shown in table 5.4.2.1.
- The transmitter aggregate output power step due to inner loop power control shall be within the range shown in table 5.4.2.2. Here a TPC_cmd group is a set of TPC_cmd values derived from a corresponding sequence of TPC commands of the same duration.

The inner loop power step is defined as the relative power difference between the mean power of the original (reference) timeslot and the mean power of the target timeslot, not including the transient duration. The transient duration is from 25 μ s before the slot boundary to 25 μ s after the slot boundary.

Table 5.4.2.1: Transmitter power control range

TPC_cmd	Transmitter power control range (all units are in dB)					
	1 dB step size		2 dB step size		3 dB step size	
	Lower	Upper	Lower	Upper	Lower	Upper
+1	+0,5	+1,5	+1	+3	+1,5	+4,5
0	-0,5	+0,5	-0,5	+0,5	-0,5	+0,5
-1	-0,5	-1,5	-1	-3	-1,5	-4,5

Table 5.4.2.2: Transmitter aggregate power control tolerance

TPC_cmd group	Transmitter power control range after 10 equal TPC_cmd group (all units are in dB)				Transmitter power control range after 7 equal TPC_cmd groups (all units are in dB)	
	1 dB step size		2 dB step size		3 dB step size	
	Lower	Upper	Lower	Upper	Lower	Upper
+1	+8	+12	+16	+24	+16	+26
0	-1	+1	-1	+1	-1	+1
-1	-8	-12	-16	-24	-16	-26
0,0,0,0,+1	+6	+14	N/A	N/A	N/A	N/A
0,0,0,0,-1	-6	-14	N/A	N/A	N/A	N/A

The UE shall meet the above requirements for inner loop power control over the power range bounded by the Minimum output power as defined in clause 5.4.3.2, and the Maximum output power supported by the UE (i.e. the actual power as would be measured assuming no measurement error). This power shall be in the range specified for the power class of the UE in clause 5.2.2.

NOTE: 3 dB inner loop power control steps are only used in compressed mode.

The reference for this requirement is TS 25.101 [1] clause 6.4.2.1.1.

The requirements for the derivation of TPC_cmd are detailed in TS 25.214 [5] clauses 5.1.2.2.2 and 5.1.2.2.3.

5.4.2.3 Test purpose

- To verify that the UE inner loop power control size and response is meet to the described value shown in clause 5.4.2.2.
- To verify that TPC_cmd is correctly derived from received TPC commands.

An excess error of the inner loop power control decreases the system capacity.

The UE shall be tested for the requirements for inner loop power control over the power range bounded by the Min power threshold for test and the Max power threshold for test.

The Min power threshold for test is defined as the Minimum Output Power Test Requirement (clause 5.4.3.5).

The Max power threshold for test is defined as the Measured Maximum output power of the UE in the relevant Step of the test (using the same method as in clause 5.2.4.2 step 2) minus the Test Tolerance specified for test 5.2 Maximum Output Power in table F.2.1.

For the final power step adjacent to the Min or Max power threshold for test, the lower step size requirement does not apply.

5.4.2.4 Method of test

5.4.2.4.1 Initial conditions

Test environment: normal; see clauses G.2.1 and G.2.2.

Frequencies to be tested: mid range; see clause G.2.4.

- 1) Connect the SS to the UE antenna connector as shown in figure A.1.
- 2) A call is set up according to the Generic call setup procedure specified in TS34.108 [3] sub clause 7.3.2, with the following exception for information elements in RADIO BEARER SETUP message. With this exception, the Power Control Algorithm for the Uplink is set to algorithm 2.

Table 5.4.2.4.1: Contents of RADIO BEARER SETUP message: AM or UM

Information Element	Value/Remark
CHOICE channel requirement - Power Control Algorithm	Uplink DPCH info Algorithm 2

- 3) Enter the UE into loopback test mode and start the loopback test.

See TS 34.108 [3] and TS 34.109 [4] for details regarding generic call setup procedure and loopback test.

5.4.2.4.2

Procedure

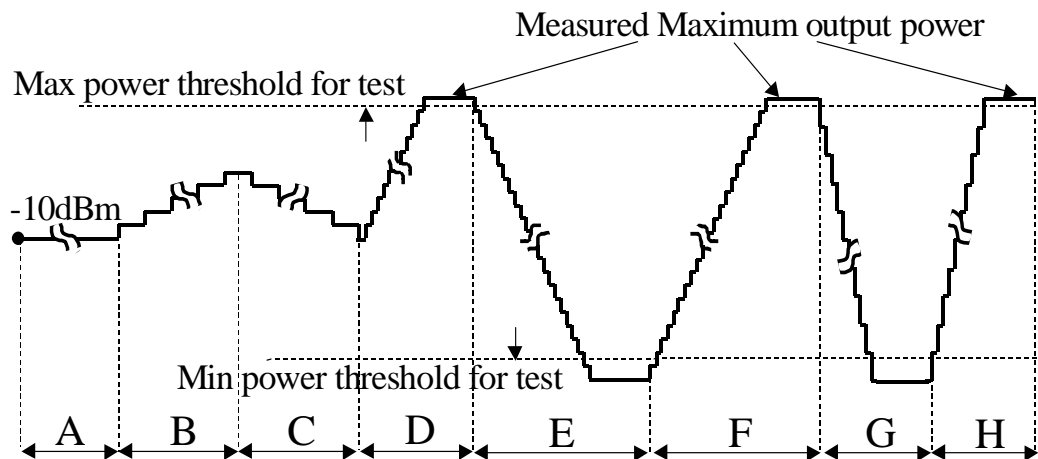

Figure 5.4.2.4 Inner Loop Power Control Test Steps

- 1) Before proceeding with paragraph (2) (Step A) below, set the output power of the UE to be in the range -10 ± 9 dBm. This may be achieved by setting the downlink signal (\hat{I}_{or}) to yield an appropriate open loop output power and/or by generating suitable downlink TPC commands from the SS.
- 2) Step A: Transmit a sequence of at least 30 and no more than 60 TPC commands, which shall commence at a frame boundary and last for a whole number of frames, and which shall contain:
 - no sets of 5 consecutive "0" or "1" commands which commence in the 1st, 6th or 11th slots of a frame;
 - at least one set of 5 consecutive "0" commands which does not commence in the 1st, 6th or 11th slots of a frame;
 - at least one set of 5 consecutive "1" commands which does not commence in the 1st, 6th or 11th slots of a frame.

The following is an example of a suitable sequence of TPC commands:

```
10000010101010111110100000101010101111010000010101010111110
```

- 3) Step B: Transmit a sequence of 50 TPC commands with the value 1.
- 4) Step C: Transmit a sequence of 50 TPC commands with the value 0.
- 5) Step D: Transmit the PHYSICAL CHANNEL RECONFIGURATION message to reconfigure the uplink channel in order to set the Power Control Algorithm to algorithm 1, and the TPC step size to 1 dB. Contents of the message is specified in the table 5.4.2.4.2.A. After the PHYSICAL CHANNEL RECONFIGURATION COMPLETE message from the UE is received, transmit a sequence of TPC commands with the value 1 until the UE output power is above the maximum power threshold.
- 6) Step E: Transmit a sequence of 150 (note 1) TPC commands with the value 0.
- 7) Step F: Transmit a sequence of 150 (note 1) TPC commands with the value 1.
- 8) Step G: Transmit the PHYSICAL CHANNEL RECONFIGURATION message to reconfigure the uplink channel in order to set the TPC step size to 2 dB (with the Power Control Algorithm remaining as algorithm 1). Contents of the message is specified in the table 5.4.2.4.2.B. After the PHYSICAL CHANNEL RECONFIGURATION COMPLETE message from the UE is received, transmit a sequence of TPC commands with the value 1 until the UE output power is above the maximum power threshold. Transmit a sequence of 75 (note 1) TPC commands with the value 0.
- 9) Step H: Transmit a sequence of 75 (note 1) TPC commands with the value 1.

10) During steps A to H the mean power of every slot shall be measured, with the following exceptions:

- In steps D and F, measurement of the mean power is not required in slots after the 10th slot after the mean power has exceeded the maximum power threshold;
- In steps E and G, measurement of the mean power is not required in slots after the 10th slot after the mean power has fallen below the minimum power threshold.

The transient periods of 25 μ s before each slot boundary and 25 μ s after each slot boundary shall not be included in the power measurements.

NOTE 1: These numbers of TPC commands are given as examples. The actual number of TPC commands transmitted in these steps shall be at least 10 more than the number required to ensure that the UE reaches the relevant maximum or minimum power threshold in each step, as shown in figure 5.4.2.4.

NOTE 2: In order to make it more practical to measure the entire power control dynamic range (between min power threshold and max power threshold with suitable margins), it is permissible to segment the power control sequences into smaller subsequence. For example, Step-E can be divided into different stages while still fulfilling the purpose of the test to measure the entire dynamic range.

Table 5.4.2.4.2.A: PHYSICAL CHANNEL RECONFIGURATION message for step D (step 5)

Information Element	Value/Remark	Version
Message Type		
UE Information Elements -RRC transaction identifier -Integrity check info - message authentication code - RRC message sequence number -Integrity protection mode info -Ciphering mode info -Activation time -New U-RNTI -New C-RNTI -RRC State Indicator -UTRAN DRX cycle length coefficient	0 SS calculates the value of MAC-I for this message and writes to this IE. The first/ leftmost bit of the bit string contains the most significant bit of the MAC-I. SS provides the value of this IE, from its internal counter. Not Present Not Present Not Present Not Present Not Present CELL_DCH Not Present	
CN Information Elements -CN Information info	Not Present	
UTRAN mobility information elements -URA identity	Not Present	
RB information elements -Downlink counter synchronisation info	Not Present	
PhyCH information elements -Frequency info	Not Present	
Uplink radio resources -Maximum allowed UL TX power -CHOICE channel requirement -Uplink DPCH power control info -CHOICE mode -DPCCH Power offset -PC Preamble -SRB delay -Power Control Algorithm -TPC step size -CHOICE mode -Scrambling code type -Scrambling code number -Number of DPDCH -spreading factor -TFCI existence -Number of FBI bits -Puncturing Limit	Not Present Uplink DPCH info FDD -40 (-80dB) 1 frame 7 frames Algorithm 1 1dB FDD Long 0 1 64 TRUE Not Present(0) 1	
Downlink radio resources -CHOICE mode -Downlink PDSCH information -Downlink information common for all radio links -Downlink DPCH info common for all RL	FDD Not Present Not Present Not Present	R99 and Rel-4 only

Table 5.4.2.4.2.B: PHYSICAL CHANNEL RECONFIGURATION message for step G (step 8)

Information Element	Value/Remark	Version
Message Type		
UE Information Elements -RRC transaction identifier -Integrity check info - message authentication code - RRC message sequence number -Integrity protection mode info -Ciphering mode info -Activation time -New U-RNTI -New C-RNTI -RRC State Indicator -UTRAN DRX cycle length coefficient	0 SS calculates the value of MAC-I for this message and writes to this IE. The first/ leftmost bit of the bit string contains the most significant bit of the MAC-I. SS provides the value of this IE, from its internal counter. Not Present Not Present Not Present Not Present Not Present Not Present CELL_DCH Not Present	
CN Information Elements -CN Information info	Not Present	
UTRAN mobility information elements -URA identity	Not Present	
RB information elements -Downlink counter synchronisation info	Not Present	
PhyCH information elements -Frequency info	Not Present	
Uplink radio resources -Maximum allowed UL TX power -CHOICE channel requirement -Uplink DPCH power control info -CHOICE mode -DPCCH Power offset -PC Preamble -SRB delay -Power Control Algorithm -TPC step size -CHOICE mode -Scrambling code type -Scrambling code number -Number of DPDCH -spreading factor -TFCI existence -Number of FBI bits -Puncturing Limit	Not Present Uplink DPCH info FDD -40 (-80dB) 1 frame 7 frames Algorithm 1 2dB FDD Long 0 1 64 TRUE Not Present(0) 1	
Downlink radio resources -CHOICE mode -Downlink PDSCH information -Downlink information common for all radio links -Downlink DPCH info common for all RL	FDD Not Present Not Present Not Present	R99 and Rel-4 only

5.4.2.5 Test requirements

Table 5.4.2.5.1: Transmitter power control range

TPC_cmd	Transmitter power control range (all units are in dB)					
	1 dB step size		2 dB step size		3 dB step size	
	Lower	Upper	Lower	Upper	Lower	Upper
+1	+0,4	+1,6	+0,85	+3,15	+1,3	+4,7
0	-0,6	+0,6	-0,6	+0,6	-0,6	+0,6
-1	-0,4	-1,6	-0,85	-3,15	-1,3	-4,7

Table 5.4.2.5.2: Transmitter aggregate power control tolerance

TPC_cmd group	Transmitter power control range after 10 equal TPC_cmd group (all units are in dB)				Transmitter power control range after 7 equal TPC_cmd groups (all units are in dB)	
	1 dB step size		2 dB step size		3 dB step size	
	Lower	Upper	Lower	Upper	Lower	Upper
+1	+7,7	+12,3	+15,7	+24,3	+15,7	+26,3
0	-1,1	+1,1	-1,1	+1,1	-1,1	+1,1
-1	-7,7	-12,3	-15,7	-24,3	-15,7	-26,3
0,0,0,0,+1	+5,7	+14,3	N/A	N/A	N/A	N/A
0,0,0,0,-1	-5,7	-14,3	N/A	N/A	N/A	N/A

- a) During Step A, the difference in mean power between adjacent slots shall be within the prescribed range for a TPC_cmd of 0, as given in table 5.4.2.5.1.
- b) During Step A, the change in mean power over 10 consecutive slots shall be within the prescribed range for a TPC_cmd group of 0, as given in table 5.4.2.5.2.
- c) During Step B, the difference in mean power between adjacent slots shall be within the prescribed range given in table 5.4.2.5.1, given that every 5th TPC_cmd should have the value +1, with a step size of 1 dB, and all other TPC_cmd should have the value 0.
- d) During Step B, the change in mean power over 50 consecutive slots shall be within the prescribed range for a TPC_cmd group of {0,0,0,0,+1}, as given in table 5.4.2.5.2.
- e) During Step C, the difference in mean power between adjacent slots shall be within the prescribed range given in table 5.4.2.5.1, given that every 5th TPC_cmd should have the value -1, with a step size of 1 dB, and all other TPC_cmd should have the value 0.
- f) During Step C, the change in mean power over 50 consecutive slots shall be within the prescribed range for a TPC_cmd group of {0,0,0,0,-1}, as given in table 5.4.2.5.2.
- g) During Step E, the difference in mean power between adjacent slots shall be within the prescribed range given in table 5.4.2.5.1 for a TPC_cmd of -1 and step size of 1 dB. This applies when the original (reference) timeslot power and the target timeslot power are between the Min power threshold for test and the Max power threshold for test derived from the Measured Maximum output power in Step D. For the power step adjacent to the Min or Max power threshold for test, the lower step size requirement does not apply.
- h) During Step E, the change in mean power over 10 consecutive slots shall be within the prescribed range for a TPC_cmd group of -1, and step size of 1 dB as given in table 5.4.2.5.2. This applies when the original (reference) timeslot power and the target timeslot power are between the Min power threshold for test and the Max power threshold for test derived from the Measured Maximum output power in Step D. The power step adjacent to the Min or Max power threshold for test should not be part of the 10 consecutive slots tested.
- i) During Step F, the difference in mean power between adjacent slots shall be within the prescribed range given in table 5.4.2.5.1 for a TPC_cmd of +1 and step size of 1 dB. This applies when the original (reference) timeslot power and the target timeslot power are between the Min power threshold for test and the Max power threshold for test derived from the Measured Maximum output power in Step F. For the power step adjacent to the Min or Max power threshold for test, the lower step size requirement does not apply.
- j) During Step F, the change in mean power over 10 consecutive slots shall be within the prescribed range for a TPC_cmd group of +1, and step size of 1 dB as given in table 5.4.2.5.2. This applies when the original (reference) timeslot power and the target timeslot power are between the Min power threshold for test and the Max power threshold for test derived from the Measured Maximum output power in Step F. The power step adjacent to the Min or Max power threshold for test should not be part of the 10 consecutive slots tested.

- k) During Step G, the difference in mean power between adjacent slots shall be within the prescribed range given in table 5.4.2.5.1 for a TPC_cmd of -1 and step size of 2 dB. This applies when the original (reference) timeslot power and the target timeslot power are between the Min power threshold for test and the Max power threshold for test derived from the Measured Maximum output power in Step F. For the power step adjacent to the Min or Max power threshold for test, the lower step size requirement does not apply.
- l) During Step G, the change in mean power over 10 consecutive slots shall be within the prescribed range for a TPC_cmd group of -1, and step size of 2 dB as given in table 5.4.2.5.2. This applies when the original (reference) timeslot power and the target timeslot power are between the Min power threshold for test and the Max power threshold for test derived from the Measured Maximum output power in Step F. The power step adjacent to the Min or Max power threshold for test should not be part of the 10 consecutive slots.
- m) During Step H, the difference in mean power between adjacent slots shall be within the prescribed range given in table 5.4.2.5.1 for a TPC_cmd of +1 and step size of 2 dB. This applies when the original (reference) timeslot power and the target timeslot power are between the Min power threshold for test and the Max power threshold for test derived from the Measured Maximum output power in Step H. For the power step adjacent to the Min or Max power threshold for test, the lower step size requirement does not apply.
- n) During Step H, the change in mean power over 10 consecutive slots shall be within the prescribed range for a TPC_cmd group of +1, and step size of 2 dB as given in table 5.4.2.5.2. This applies when the original (reference) timeslot power and the target timeslot power are between the Min power threshold for test and the Max power threshold for test derived from the Measured Maximum output power in Step H. The power step adjacent to the Min or Max power threshold for test should not be part of the 10 consecutive slots tested.

NOTE: If the above Test Requirement differs from the Minimum Requirement then the Test Tolerance applied for this test is non-zero. The Test Tolerance for this test is defined in clause F.2 and the explanation of how the Minimum Requirement has been relaxed by the Test Tolerance is given in clause F.4.

5.4.3 Minimum Output Power

5.4.3.1 Definition and applicability

The minimum controlled output power of the UE is when the power control setting is set to a minimum value. This is when both the inner loop and open loop power control indicate a minimum transmit output power is required.

The requirements and this test apply to all types of UTRA for the FDD UE.

5.4.3.2 Minimum Requirements

The minimum output power is defined as the mean power in one timeslot. The minimum transmit power shall be less than -50 dBm.

The normative reference for this requirement is TS 25.101 [1] clause 6.4.3.1.

5.4.3.3 Test purpose

To verify that the UE minimum transmit power is less than -50 dBm.

An excess minimum output power increases the interference to other channels, and decreases the system capacity.

5.4.3.4 Method of test

5.4.3.4.1 Initial conditions

Test environment: normal, TL/VL, TL/VH, TH/VL, TH/VH; see clauses G.2.1 and G.2.2.

Frequencies to be tested: low range, mid range, high range; see clause G.2.4.

- 1) Connect the SS to the UE antenna connector as shown in figure A.1.
- 2) A call is set up according to the Generic call setup procedure in TS34.108 [3] sub clause 7.3.2.
- 3) Enter the UE into loopback test mode and start the loopback test.

See TS 34.108 [3] and TS 34.109 [4] for details regarding generic call setup procedure and loopback test.

5.4.3.4.2 Procedure

- 1) Set and send continuously Down power control commands to the UE.
- 2) Measure the mean power of the UE.

5.4.3.5 Test requirements

The measured power, derived in step 2), shall be less than -49 dBm.

NOTE: If the above Test Requirement differs from the Minimum Requirement then the Test Tolerance applied for this test is non-zero. The Test Tolerance for this test is defined in clause F.2 and the explanation of how the Minimum Requirement has been relaxed by the Test Tolerance is given in clause F.4.

5.4.4 Out-of-synchronisation handling of output power

5.4.4.1 Definition and applicability

The receiver characteristics in this section are specified at the antenna connector of the UE. For UEs with more than one receiver antenna connector the AWGN signals applied to each receiver antenna connector shall be uncorrelated. The levels of the test signal applied to each of the antenna connectors shall be as defined in section 5.4.4.2 below.

The UE shall monitor the DPCCH quality in order to detect a loss of the signal on Layer 1, as specified in TS 25.214 [5]. The thresholds Q_{out} and Q_{in} specify at what DPCCH quality levels the UE shall shut its power off and when it shall turn its power on respectively. The thresholds are not defined explicitly, but are defined by the conditions under which the UE shall shut its transmitter off and turn it on, as stated in this clause.

The DPCCH quality shall be monitored in the UE and compared to the thresholds Q_{out} and Q_{in} for the purpose of monitoring synchronization. The threshold Q_{out} should correspond to a level of DPCCH quality where no reliable detection of the TPC commands transmitted on the downlink DPCCH can be made. This can be at a TPC command error ratio level of e.g. 30%. The threshold Q_{in} should correspond to a level of DPCCH quality where detection of the TPC commands transmitted on the downlink DPCCH is significantly more reliable than at Q_{out} . This can be at a TPC command error ratio level of e.g. 20%.

The requirements of this test apply to all types of UTRA for the FDD UE.

5.4.4.2 Minimum Requirements

When the UE estimates the DPCCH quality or the quality of the TPC fields of the F-DPCH frame received from the serving HS-DSCH cell over the last 160 ms period or quality of the TPC fields of the F-DPCH from the serving HS-DSCH cell over the previous 240 slots in which the TPC symbols are known to be present when the discontinuous uplink DPCCH transmission operation is enabled to be worse than a threshold Q_{out} , the UE shall shut its transmitter off within 40 ms. The UE shall not turn its transmitter on again until the DPCCH quality exceeds an acceptable level Q_{in} . When the UE estimates the DPCCH quality or the quality of the TPC fields of the F-DPCH frame received from the serving HS-DSCH cell over the last 160 ms period or quality of the TPC fields of the F-DPCH from the serving HS-DSCH cell over the previous 240 slots in which the TPC symbols are known to be present when the discontinuous uplink DPCCH transmission operation is enabled to be better than a threshold Q_{in} , the UE shall again turn its transmitter on within 40 ms.

The UE transmitter shall be considered "off" if the transmitted power is below the level defined in subclause 6.5.1 (Transmit off power). Otherwise the transmitter shall be considered as "on".

The normative reference for this requirement is TS 25.101 [1] clause 6.4.4.1.

The quality levels at the thresholds Q_{out} and Q_{in} correspond to different signal levels depending on the downlink conditions DCH parameters. For the conditions in table 5.4.4.1, a signal with the quality at the level Q_{out} can be generated by a DPCCH_Ec/Ior ratio of -25 dB, and a signal with Q_{in} by a DPCCH_Ec/Ior ratio of -21 dB. The DL reference measurement channel (12.2) kbps specified in subclause C.3.1 and with static propagation conditions. The downlink physical channels, other than those specified in table 5.4.4.1, are as specified in table E.3.3 of Annex E.

Table 5.4.4.1: DCH parameters for test of Out-of-synch handling test case

Parameter	Value	Unit
\hat{I}_{or}/I_{oc}	-1	dB
I_{oc}	-60	dBm / 3,84 MHz
$\frac{DPDCH_E_c}{I_{or}}$	See Figure 5.4.4.1: Before point A -16,6 After point A Not defined See note in clause 5.4.4.3	dB
$\frac{DPCCH_E_c}{I_{or}}$	See table 5.4.4.2	dB
Information Data Rate	12,2	kbps

Table 5.4.4.2: Minimum Requirements for DPCCH_Ec/Ior levels

Clause from figure 5.4.4.1	DPCCH_Ec/Ior	Unit
Before A	-16,6	dB
A to B	-22,0	dB
B to D	-28,0	dB
D to E	-24,0	dB
After E	-18,0	dB

Figure 5.4.4.1 shows an example scenario where the DPCCH_Ec/Ior ratio varies from a level where the DPCH is demodulated under normal conditions, down to a level below Q_{out} where the UE shall shut its power off and then back up to a level above Q_{in} where the UE shall turn the power back on.

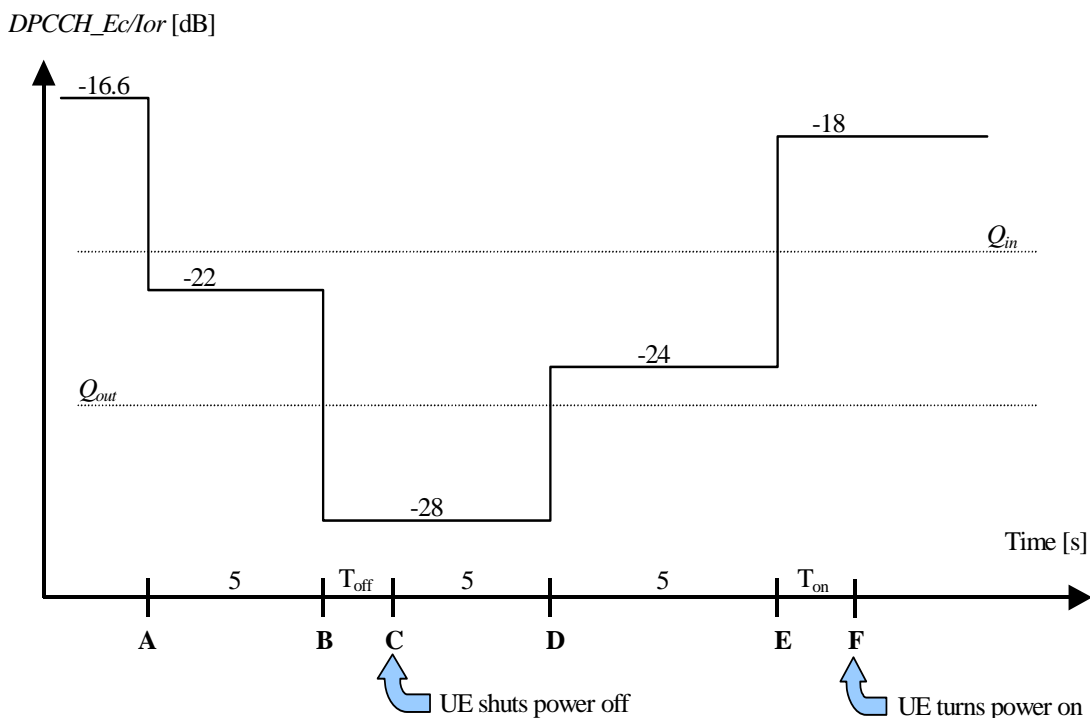

Figure 5.4.4.1: Test case for out-of-synch handling in the UE.

In this test case, the requirements for the UE are that:

1. The UE shall not shut its transmitter off before point B.
2. The UE shall shut its transmitter off before point C, which is $T_{off} = 200$ ms after point B.
3. The UE shall not turn its transmitter on between points C and E.
4. The UE shall turn its transmitter on before point F, which is $T_{on} = 200$ ms after point E.

The reference for this test case is TS 25.101 [1] clause 6.4.4.2.

5.4.4.3 Test purpose

To verify that the UE monitors the DPCCH quality and turns its transmitter on or off according to DPCCH level diagram specified in figure 5.4.4.1.

NOTE 1: DPDCH_Ec/I_{or} after point A is not defined in table 5.4.4.1. However it is assumed that DPDCH and DPCCH power level are same on DL 12,2 kbps reference measurement channel for testing. (PO1, PO2, and PO3 are zero.)

NOTE 2: The test case covers only the continuous uplink DPCCH transmission scenario.

5.4.4.4 Method of test

5.4.4.4.1 Initial conditions

Test environment: normal; see clauses G.2.1 and G.2.2.

Frequencies to be tested: mid range; see clause G.2.4.

- 1) Connect the SS to the UE antenna connector as shown in figure A.1.
- 2) A call is set up according to the Generic call setup procedure in TS34.108 [3] sub clause 7.3.2, with the following exception for information elements in System Information Block type 1 specified in TS 34.108 [3] subclause 6.1.0b.

Table 5.4.4.2A: System Information Block type 1 message

Information Element	Value/Remark
UE Timers and constants in connected mode - T313 - N313	15 seconds 200

- 3) DCH parameters are set up according to table 5.4.4.1 with DPCCH_Ec/I_{or} ratio level at -16,6 dB. The other RF parameters are set up according to clause E.3.3.
- 4) Enter the UE into loopback test mode and start the loopback test.

See TS 34.108 [3] and TS 34.109 [4] for details regarding generic call setup procedure and loopback test.

5.4.4.4.2 Procedure

- 1) The SS sends continuously Up power control commands to the UE until the UE transmitter power reach maximum level.
- 2) The SS controls the DPCCH_Ec/I_{or} ratio level according to clause 'A to B' as defined in table 5.4.4.3. The SS monitors the UE transmitted power for 5 seconds and verifies that the UE transmitter is not switched off during this time.
- 3) The SS controls the DPCCH_Ec/I_{or} ratio level according to clause 'B to D' as defined in table 5.4.4.3. The SS waits 200 ms and then verifies that the UE transmitter has been switched off.
- 4) The SS monitors the UE transmitted power for 5 seconds and verifies that the UE transmitter is not switched on during this time.
- 5) The SS controls the DPCCH_Ec/I_{or} ratio level according to clause 'D to E' as defined in table 5.4.4.3. The SS monitors the UE transmitted power for 5 s and verifies that the UE transmitter is not switched on during this time.
- 6) The SS controls the DPCCH_Ec/I_{or} ratio level according to clause 'After E' as defined in table 5.4.4.3. The SS waits 200 ms and then verifies that the UE transmitter has been switched on.

5.4.4.5 Test requirements

Table 5.4.4.3: Test Requirements for DPCCH_Ec/Ior levels

Clause from figure 5.4.4.1	DPCCH_Ec/Ior	Unit
Before A	-16,6	dB
A to B	-21,6	dB
B to D	-28,4	dB
D to E	-24,4	dB
After E	-17,6	dB

To pass the test, steps 1 through 6 of the procedure in clause 5.4.4.4.2 must be fulfilled.

The UE transmitter off criterion and its tolerances is defined in clause 5.5.1 (Transmit off power).

The UE transmitter on criterion and its tolerances is defined in clause 5.4.3 (Minimum Output Power). The UE transmitter is considered to be on if the UE transmitted power is higher than minimum output power.

NOTE: If the above Test Requirement differs from the Minimum Requirement then the Test Tolerance applied for this test is non-zero. The Test Tolerance for this test is defined in clause F.2 and the explanation of how the Test Requirement has been relaxed by the Test Tolerance is given in clause F.4.

5.5 Transmit ON/OFF Power

5.5.1 Transmit OFF Power

5.5.1.1 Definition and applicability

Transmit OFF power is defined as the RRC filtered mean power when the transmitter is off. The transmit OFF power state is when the UE does not transmit. During transmission gaps in UL compressed mode, the UE is not considered to be in the OFF state.

The requirements and this test apply to all types of UTRA for the FDD UE.

5.5.1.2 Minimum Requirements

The requirement for the transmit OFF power shall be less than -56 dBm.

The normative reference for this requirement is TS 25.101 [1] clause 6.5.1.1.

5.5.1.3 Test purpose

To verify that the UE transmit OFF power is less than -56 dBm.

An excess transmit OFF power increases the interference to other channels, and decreases the system capacity.

5.5.1.4 Method of test

This test is covered by clause 5.5.2 Transmit ON/OFF Time mask.

5.5.1.5 Test requirements

The measured RRC filtered mean power shall be less than -55 dBm.

NOTE: If the above Test Requirement differs from the Minimum Requirement then the Test Tolerance applied for this test is non-zero. The Test Tolerance for this test is defined in clause F.2 and the explanation of how the Minimum Requirement has been relaxed by the Test Tolerance is given in clause F.4.

5.5.2 Transmit ON/OFF Time mask

5.5.2.1 Definition and applicability

The time mask for transmit ON/OFF defines the ramping time allowed for the UE between transmit OFF power and transmit ON power. Possible ON/OFF scenarios for release 99 and release 4 only are PRACH, CPCH or uplink compressed mode. For release 5 and later the possible ON/OFF scenarios are PRACH or uplink compressed mode.

The requirements and this test apply to all types of UTRA for the FDD UE.

5.5.2.2 Minimum requirements

The mean power of successive slots shall be calculated according to figure 5.5.1 for PRACH preambles, and figure 5.5.2 for all other cases. The off signal is defined as the RRC filtered mean power.

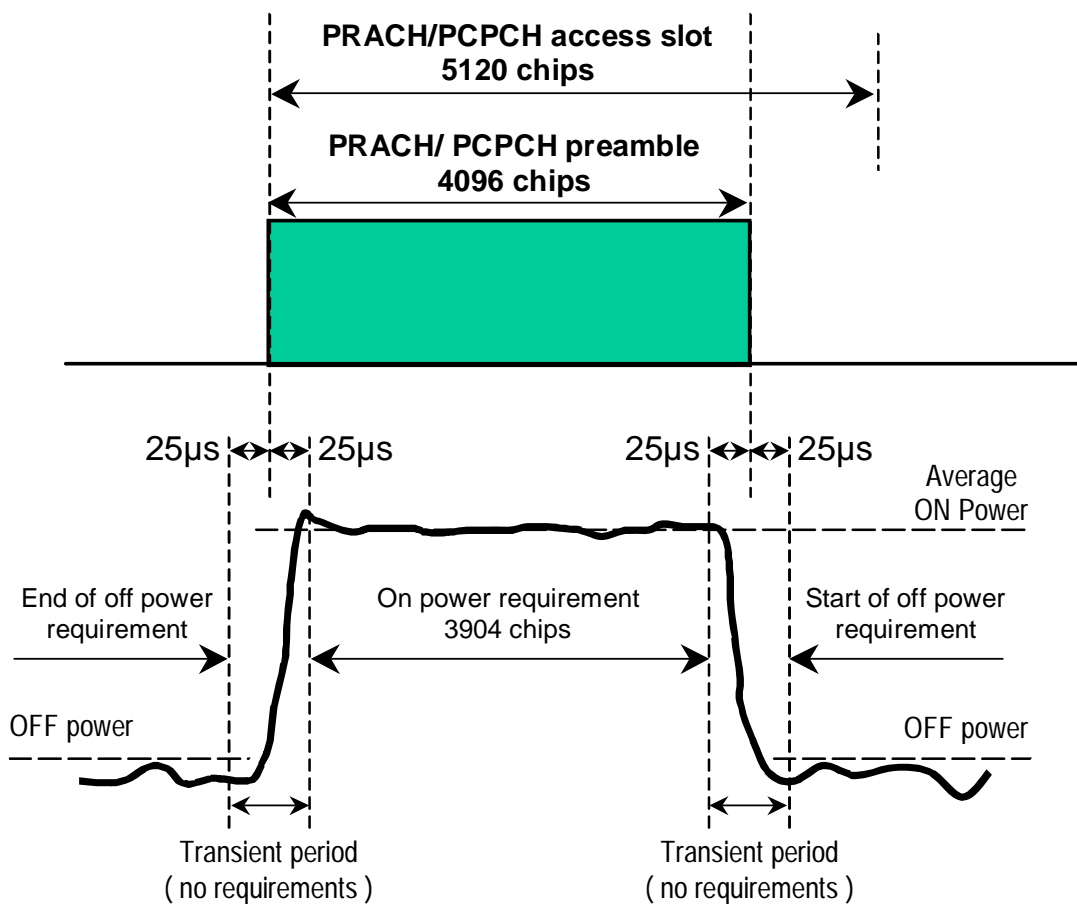

Figure 5.5.1: Transmit ON/OFF template for PRACH preambles

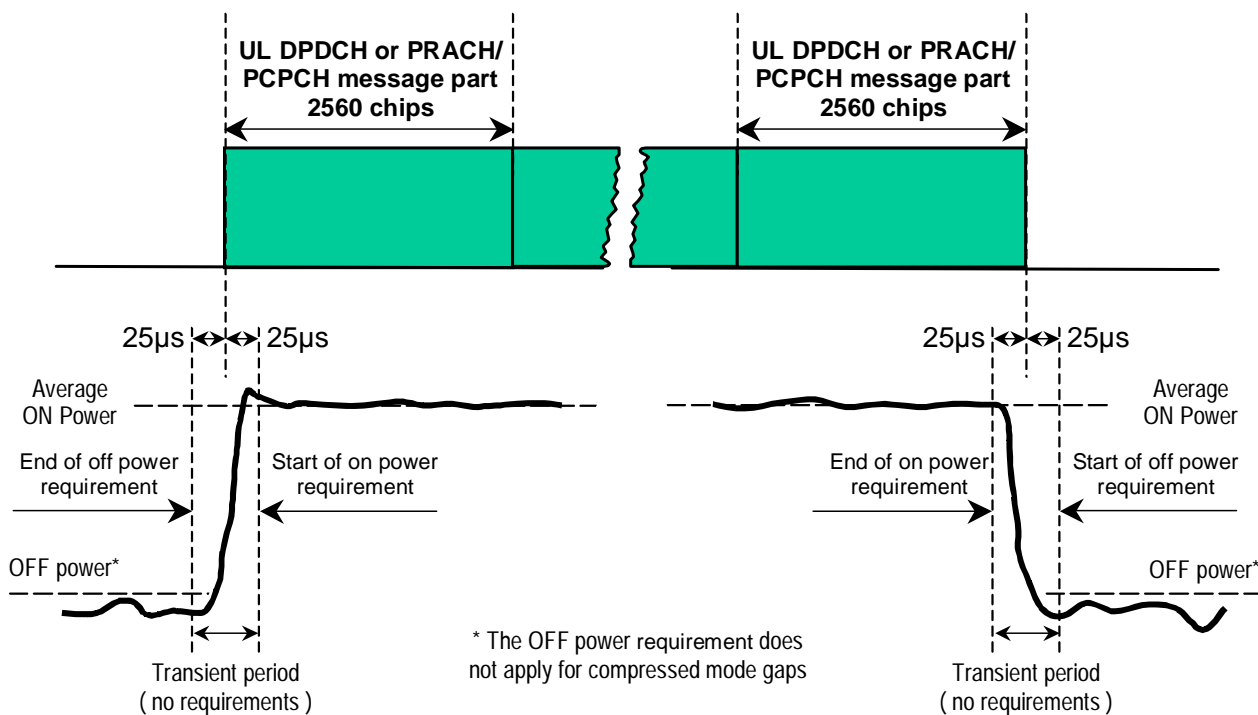

Figure 5.5.2: Transmit ON/OFF template for all other On/Off cases

OFF Power is defined in clause 5.5.1.2.

ON power is defined as the mean power. The specification depends on each possible case.

- First preamble of PRACH: Open loop accuracy (table 5.4.1.1).
- During preamble ramping of the RACH and between final RACH preamble and RACH message part: Accuracy depending on size of the required power difference (table 5.5.2.1).
- After transmission gaps in compressed mode: Accuracy as in table 5.7.1.
- Power step to Maximum Power: Maximum power accuracy (table 5.2.1).

Table 5.5.2.1: Transmitter power difference tolerance for RACH preamble ramping, and between final RACH preamble and RACH message part

Power difference size ΔP [dB]	Transmitter power difference tolerance [dB]
0	± 1
1	± 1
2	$\pm 1,5$
3	± 2
$4 \leq \Delta P \leq 10$	$\pm 2,5$
$11 \leq \Delta P \leq 15$	$\pm 3,5$
$16 \leq \Delta P \leq 20$	$\pm 4,5$
$21 \leq \Delta P$	$\pm 6,5$

The reference for this requirement is TS 25.101 [1] clause 6.5.2.1.

This is tested using PRACH operation.

5.5.2.3 Test purpose

To verify that the power ON/OFF ratio of the PRACH shown in figure 5.5.1 meets the requirements given in 5.5.2.2.

Transmission of the wrong power increases interference to other channels, or increases transmission errors in the uplink's own channel.

5.5.2.4 Method of test

5.5.2.4.1 Initial conditions

Test environment: normal, TL/VL, TL/VH, TH/VL, TH/VH; see clauses G.2.1 and G.2.2.

Frequencies to be tested: low range, mid range, high range; see clause G.2.4.

- 1) Connect the SS to the UE antenna connector as shown in figure A.1.
- 2) Channel conditions are initially set up with received CPICH_RSCP > -85 dBm. The relative power level of downlink physical channels to I_{or} are set up according to clause E.2.1. The parameter settings of the cell are set up according to table 5.5.2.1A.
- 3) Switch on the phone.
- 4) After the UE has performed registration and entered idle mode, \hat{I}_{or} is set up according to table 5.5.2.2. The relative power level of downlink physical channels to I_{or} are set up according to clause E.2.1
- 5) A call is set up according to the Generic call setup procedure, in [3] clause 7.3.1 with channel conditions according the test parameters in table 5.5.2.3.

The RACH procedure within the call setup is used for the test. The number of the available subchannels should be limited to one. This ensures that the preamble sequence is known to the SS. The preamble retransmission shall be at least 3. The power ramping step size shall be 1 dB. Note that the maximum number of preamble retransmissions is limited to 5 due to the fact that the commanded uplink power exceeds the allowed uplink power of more than 6 dB. The SS shall not send either an ACK or a NACK.

Table 5.5.2.1A: Settings for the serving cell

Parameter	Unit	Cell 1			
		Power class 1	Power class 2	Power class 3	Power class 4
Cell type		Serving cell			
UTRA RF Channel Number		Channel 1			
Qqualmin	dB	-24			
Qrxlevmin	dBm	-115			
UE_TXPWR_MAX_RACH	dBm	33	27	24	21

Table 5.5.2.2: Test parameters for Transmit ON/OFF Time mask (UE)

Parameter	Level / Status	Unit
\hat{I}_{or}	See table 5.5.2.3	dBm / 3,84 MHz

Table 5.5.2.3: Test parameters for Transmit ON/OFF Time mask (SS)

Parameter		Power Class 1	Power Class 2	Power Class 3	Power Class 4	Unit
\hat{I}_{or} (note 1)		<REF \hat{I}_{or} >	<REF \hat{I}_{or} >	<REF \hat{I}_{or} >	<REF \hat{I}_{or} >	dBm / 3,84 MHz
CPICH_RSCP (notes 1 and 2)		<REF \hat{I}_{or} > + CPICH_Ec / Ior	<REF \hat{I}_{or} > + CPICH_Ec / Ior	<REF \hat{I}_{or} > + CPICH_Ec / Ior	<REF \hat{I}_{or} > + CPICH_Ec / Ior	dBm
Primary CPICH DL TX power		+19	+19	+19	+19	dBm
Simulated path loss = Primary CPICH DL TX power – CPICH_RSCP	Band I, IV, VI, X	128.9	128.9	128.9	128.9	dB
	Band II, V, VII, XI	126.9	126.9	126.9	126.9	
	Band III, VIII	125.9	125.9	125.9	125.9	
	Band IX	127.9	127.9	127.9	127.9	
UL interference	Band I, IV, VI, X	–86	–92	–95	–98	dBm
	Band II, V, VII, XI	–84	–90	–93	–96	
	Band III, VIII	–83	–89	–92	–95	
	Band IX	–85	–91	–94	–97	
Constant Value		–10	–10	–10	–10	dB
Expected nominal UE TX power (note 3)		+32.9	+26.9	+23.9	+20.9	dBm
NOTE 1: <REF \hat{I}_{or} > is specified in Table 6.2.2, and CPICH_Ec / Ior is specified in Table E.2.2. The power level of S-CCPCH should be defined because S-CCPCH is transmitted during Preamble RACH transmission period. The power level of S-CCPCH is set to –5.3 dB relative to \hat{I}_{or} .						
NOTE 2: The purpose of this parameter is to calculate the Expected nominal UE TX power.						
NOTE 3: The Expected nominal UE TX power is calculated by using the equation in the clause 8.5.7 Open Loop Power Control of TS 25.331 [8].						

5.5.2.4.2 Procedure

- 1) Set the TX output level of the SS to obtain \hat{I}_{or} at the UE antenna connector and select the test parameters of table 5.5.2.3 according to the power class. \hat{I}_{or} shall be according to table 5.5.2.3.
- 2) Measure the mean power (ON power) of the UE on the first PRACH preamble according to the timing in figure 5.5.1.
- 3) Measure the RRC filtered mean power (OFF power) in a 2368 chip time interval before a transient period of 25 μ s (96 chips) prior to a RACH preamble (ON power). Measure the RRC filtered mean power (OFF power) in a 2368 chip time interval after a transient period of 25 μ s (96 chips) after a RACH preamble (ON power). Due to the dynamic range between the ON and OFF power measurements, the OFF power measurements can be made on subsequent PRACH preambles rather than adjacent to the first PRACH preamble.

5.5.2.5 Test requirements

The deviation with respect to the Expected nominal UE TX power (table 5.5.2.3), derived in step 2), shall not exceed the prescribed upper tolerance in table 5.2.2 (clause 5.2.5) and lower tolerance in table 5.4.1.4. (clause 5.4.1.5) for the first PRACH preamble.

The measured RRC filtered mean power, derived in step 3), shall be less than –55 dBm. (clause 5.5.1.5).

5.6 Change of TFC

5.6.1 Definition and applicability

A change of TFC (Transport Format Combination) in uplink means that the power in the uplink varies according to the change in data rate. DTX, where the DPDCH is turned off, is a special case of variable data, which is used to minimise the interference between UE(s) by reducing the UE transmit power when voice, user or control information is not present.

The requirements and this test apply to all types of UTRA for the FDD UE.

5.6.2 Minimum requirements

A change of output power is required when the TFC, and thereby the data rate, is changed. The ratio of the amplitude between the DPDCH codes and the DPCCH code will vary. The power step due to a change in TFC shall be calculated in the UE so that the power transmitted on the DPCCH shall follow the inner loop power control. The step in total transmitted power (DPCCH + DPDCH) shall then be rounded to the closest integer dB value. A power step exactly half-way between two integer values shall be rounded to the closest integer of greater magnitude. The accuracy of the power step, given the step size is specified in table 5.6.1. The power change due to a change in TFC is defined as the relative power difference between the mean power of the original (reference) timeslot and the mean power of the target timeslot, not including the transient duration. The transient duration is from 25 μs before the slot boundary to 25 μs after the slot boundary.

Table 5.6.1: Transmitter power step tolerance

Power control step size (Up or down) ΔP [dB]	Transmitter power step tolerance [dB]
0	±0,5
1	±0,5
2	±1,0
3	±1,5
4 ≤ ΔP ≤ 10	±2,0
11 ≤ ΔP ≤ 15	±3,0
16 ≤ ΔP ≤ 20	±4,0
21 ≤ ΔP	±6,0

Clause C.2.1 defines the UL reference measurement channels (12,2 kbps) for TX test and the power ratio between DPCCH and DPDCH as -5,46 dB. Therefore, only one power control step size is selected as minimum requirement from table 5.6.1. The accuracy of the power step, given the step size is specified in table 5.6.2.

Table 5.6.2: Transmitter power step tolerance for test

Quantized amplitude ratios β _c and β _d	Power control step size (Up or down) ΔP [dB]	Transmitter power step tolerance [dB]
β _c = 0,5333, β _d = 1,0	7	±2

The transmit power levels versus time shall meet the mask specified in figure 5.6.1.

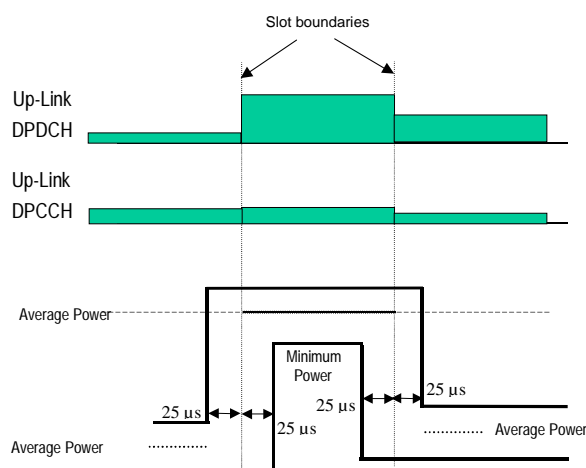

Figure 5.6.1: Transmit template during TFC change

The UL reference measurement channel (12,2 kbps) is a fixed rate channel. Therefore, DTX, where the DPDCH is turned off, is tested, as shown in figure 5.6.2.

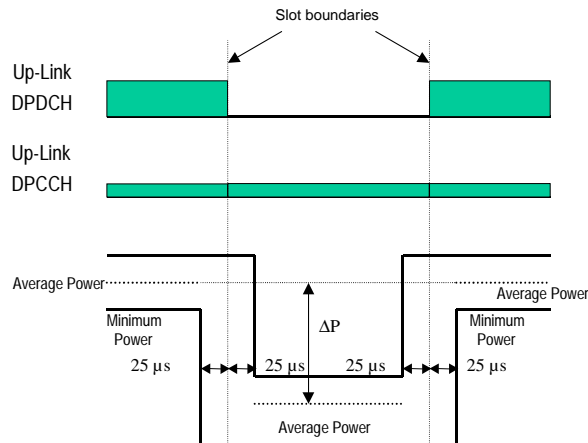

Figure 5.6.2: Transmit template during DTX

The reference for this requirement is TS 25.101 [1] clause 6.5.3.1.

5.6.3 Test purpose

To verify that the tolerance of power control step size does not exceed the described value shown in table 5.6.2.

To verify that the DTX ON/OFF power levels versus time meets the described mask shown in figure 5.6.2.

5.6.4 Method of test

5.6.4.1 Initial conditions

Test environment: normal; see clauses G.2.1 and G.2.2.

Frequencies to be tested: mid range; see clause G.2.4.

- 1) Connect the SS to the UE antenna connector as shown in figure A.1.
- 2) A call is set up according to the Generic call setup procedure in TS34.108 [3] sub clause 7.3.2. The Uplink DPCH Power Control Info shall specify the Power Control Algorithm as algorithm 2 for interpreting TPC commands.
- 3) Enter the UE into loopback test mode and start the loopback test.

See TS 34.108 [3] and TS 34.109 [4] for details regarding generic call setup procedure and loopback test.

5.6.4.2 Procedure

- 1) Set the power level of the UE to , 0 dBm \pm 1 dB.
- 2) Send alternating "0" and "1" TPC commands in the downlink so as to satisfy the condition of obtaining TPC_cmd = 0.
- 3) Measure the mean output power of the UE in two cases, both DPDCH and DPCCH are ON and only DPCCH is ON. The measurements shall not include the transient periods.

5.6.5 Test requirements

The difference in mean power between DPDCH ON and OFF, derived in step 3), shall not exceed the prescribed range in table 5.6.3.

Table 5.6.3: Transmitter power step tolerance for test

Quantized amplitude ratios β_c and β_d	Power control step size (Up or down) ΔP [dB]	Transmitter power step tolerance [dB]
$\beta_c = 0,5333, \beta_d = 1,0$	7	± 2.3

NOTE: If the above Test Requirement differs from the Minimum Requirement then the Test Tolerance applied for this test is non-zero. The Test Tolerance for this test is defined in clause F.2 and the explanation of how the Minimum Requirement has been relaxed by the Test Tolerance is given in clause F.4.

5.7 Power setting in uplink compressed mode

5.7.1 Definition and applicability

Compressed mode in uplink means that the power in uplink is changed.

The requirements and this test apply to all types of UTRA for the FDD UE that support UL or combined UL/DL compressed modes.

5.7.2 Minimum requirements

A change of output power is required during uplink compressed frames since the transmission of data is performed in a shorter interval. The ratio of the amplitude between the DPDCH codes and the DPCCH code will also vary. The power step due to compressed mode shall be calculated in the UE so that the energy transmitted on the pilot bits during each transmitted slot shall follow the inner loop power control.

Thereby, the power during compressed mode, and immediately afterwards, shall be such that the mean power of the DPCCH follows the steps due to inner loop power control combined with additional steps of $10\log_{10}(N_{\text{pilot,prev}} / N_{\text{pilot,curr}})$ dB where $N_{\text{pilot,prev}}$ is the number of pilot bits in the previously transmitted slot, and $N_{\text{pilot,curr}}$ is the current number of pilot bits per slot.

The resulting step in total transmitted power (DPCCH + DPDCH) shall then be rounded to the closest integer dB value. A power step exactly half-way between two integer values shall be rounded to the closest integer of greatest magnitude. The accuracy of the power step, given the step size, is specified in table 5.6.1 in clause 5.6.2. The power step is defined as the relative power difference between the mean power of the original (reference) timeslot and the mean power of the target timeslot, when neither the original timeslot nor the reference timeslot are in a transmission gap. The transient duration is not included, and is from 25 μ s before the slot boundary to 2.5 μ s after the slot boundary.

In addition to any power change due to the ratio $N_{\text{pilot,prev}} / N_{\text{pilot,curr}}$, the mean power of the DPCCH in the first slot after a compressed mode transmission gap shall differ from the mean power of the DPCCH in the last slot before the transmission gap by an amount Δ_{RESUME} , where Δ_{RESUME} is calculated as described in clause 5.1.2.3 of TS 25.214 [5].

The resulting difference in the total transmitted power (DPCCH + DPDCH) shall then be rounded to the closest integer dB value. A power difference exactly half-way between two integer values shall be rounded to the closest integer of greatest magnitude. The accuracy of the resulting difference in the total transmitted power (DPCCH + DPDCH) after a transmission gap of up to 14 slots shall be as specified in table 5.7.1.

Table 5.7.1: Transmitter power difference tolerance after a transmission gap of up to 14 slots

Power difference (Up or down) ΔP [dB]	Transmitter power step tolerance after a transmission gap [dB]
$\Delta P \leq 2$	+/- 3
3	+/- 3
$4 \leq \Delta P \leq 10$	+/- 3.5
$11 \leq \Delta P \leq 15$	+/- 4
$16 \leq \Delta P \leq 20$	+/- 4.5
$21 \leq \Delta P$	+/- 6.5

The power difference is defined as the difference between the mean power of the original (reference) timeslot before the transmission gap and the mean power of the target timeslot after the transmission gap, not including the transient

durations. The transient durations at the start and end of the transmission gaps are each from 25 μs before the slot boundary to 25 μs after the slot boundary.

The transmit power levels versus time shall meet the mask specified in figure 5.7.1.

The reference for this requirement is TS 25.101 [1] clause 6.5.4.1.

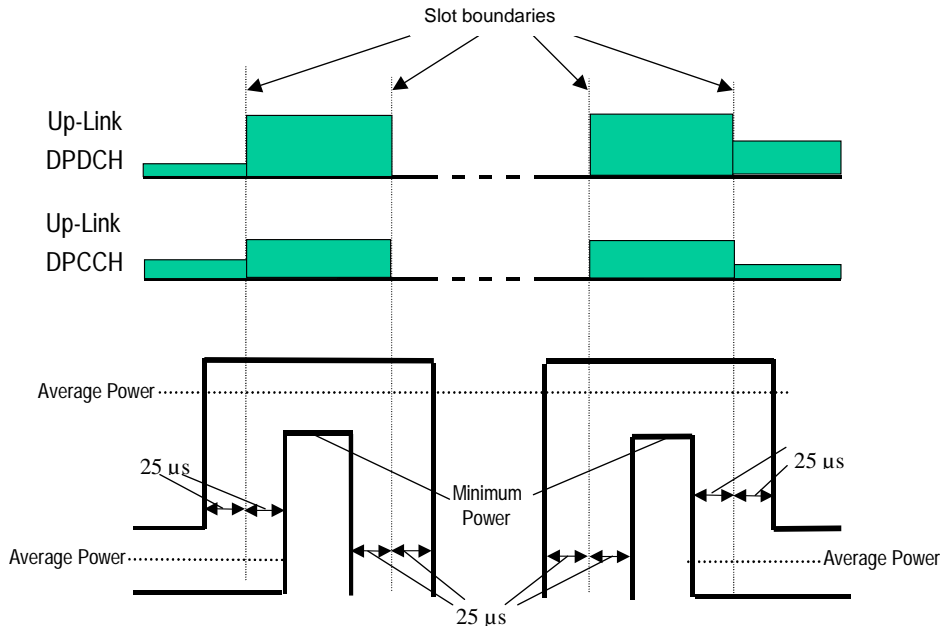

Figure 5.7.1: Transmit template during Compressed mode

For RPL (Recovery Period Length) slots after the transmission gap, where RPL is the minimum out of the transmission gap length and 7 slots, the UE shall use the power control algorithm and step size specified by the signalled Recovery Period Power Control Mode (RPP), as detailed in TS 25.214 [5] clause 5.1.2.3.

When nominal 3 dB power control steps are used in the recovery period, the transmitter mean power steps due to inner loop power control shall be within the range shown in table 5.7.2, and the transmitter aggregate mean power step due to inner loop power control shall be within the range shown in table 5.7.3, excluding any other power changes due, for example, to changes in spreading factor or number of pilot bits.

Table 5.7.2: Transmitter power control range for 3dB step size

TPC_cmd	Transmitter power control range for 3dB step size	
	Lower	Upper
+1	+1,5 dB	+4,5 dB
0	-0,5 dB	+0,5 dB
-1	-1,5 dB	-4,5 dB

Table 5.7.3: Transmitter aggregate power control range for 3dB step size

TPC_cmd group	Transmitter power control range after 7 equal TPC_cmd groups	
	Lower	Upper
+1	+16 dB	+26 dB
0	-1 dB	+1 dB
-1	-16 dB	-26 dB

The reference for this requirement is TS 25.101 [1] clause 6.4.2.1.1.

5.7.3 Test purpose

To verify that the changes in uplink transmit power in compressed mode are within the prescribed tolerances.

Excess error in transmit power setting in compressed mode increases the interference to other channels, or increases transmission errors in the uplink.

5.7.4 Method of test

5.7.4.1 Initial conditions

Test environment: normal; see clauses G.2.1 and G.2.2.

Frequencies to be tested: mid range; see clause G.2.4.

- 1) Connect the SS to the UE antenna connector as shown in figure A.1.
- 2) A call is set up according to the Generic call setup procedure in TS34.108 [3] sub clause 7.3.2. The 12,2 kbps UL reference measurement channel is used, with gain factors $\beta_c = 0,5333$ and $\beta_d = 1,0$ in non-compressed frames. Slot formats 0 and 0B are used on the uplink DPCCH.
- 3) Enter the UE into loopback test mode and start the loopback test.

See TS 34.108 [3] and TS 34.109 [4] for details regarding generic call setup procedure and loopback test.

5.7.4.2 Procedure

NOTE: CFNs are given in this procedure for reference as examples only. A fixed offset may be applied to the CFNs.

- 1) Before proceeding with step (3) below, set the output power of the UE to be in the range -36 ± 9 dBm. This may be achieved by setting the downlink signal (\hat{I}_{or}) to yield an appropriate open loop output power and/or by generating suitable downlink TPC commands from the SS.
- 2) Transmit the PHYSICAL CHANNEL RECONFIGURATION message to set the uplink power control parameters to use Algorithm 1 and a step size of 2 dB, and to set the compressed mode parameters shown in table 5.7.5. The contents of the message are specified in table 5.7.9. This set of compressed mode parameters defines the compressed mode pattern which is used to test the implementation of:
 - a) in steps (3) and (4), upward 3 dB output power steps and the implementation of a downward power change when resuming transmission after a compressed mode gap, and
 - b) in steps (7) and (8), downward 3dB output power steps and the implementation of an upward power change when resuming transmission after a compressed mode gap.

Table 5.7.5: Parameters for pattern A for compressed mode test

Parameter	Meaning	Value
TGPRC	Number of transmission gap patterns within the Transmission Gap Pattern Sequence	1
TGCFN	Connection Frame Number of the first frame of the first pattern within the Transmission Gap Pattern Sequence	0
TGSN	Slot number of the first transmission gap slot within the TGCFN	2
TGL1	Length of first transmission gap within the transmission gap pattern	7 slots
TGL2	Length of second transmission gap within the transmission gap pattern	7 slots
TGD	Duration between the starting slots of two consecutive transmission gaps within a transmission gap pattern	15 slots
TGPL1	Duration of transmission gap pattern 1	3 frames
TGPL2	Duration of transmission gap pattern 2	R99 and Rel-4: Omit Rel-5 and later releases: Not applicable
RPP	Recovery Period Power Control Mode	Mode 1
ITP	Initial Transmit Power Mode	Mode 1
UL/DL Mode	Defines whether UL only or combined UL/DL compressed mode is used	UL only or UL/DL
Downlink Compressed Mode Method	Method for generating downlink compressed mode gap	SF/2
Uplink Compressed Mode Method	Method for generating uplink compressed mode gap	SF/2
Scrambling code change	Indicates whether the alternative scrambling code is used	No code change
Downlink frame type	Downlink compressed frame structure	A
DeltaSIR	Delta in DL SIR target value to be set in the UE during compressed frames	0
DeltaSIRafter	Delta in DL SIR target value to be set in the UE one frame after the compressed frames	0

The resulting compressed mode pattern is shown in figure 5.7.2.

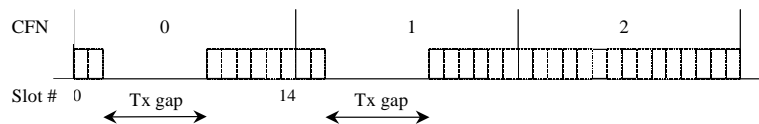

Figure 5.7.2: Pattern A for compressed mode test

- 3) After the PHYSICAL CHANNEL RECONFIGURATION COMPLETE message from the UE is received, transmit TPC commands on the downlink as shown in table 5.7.6.

Table 5.7.6: TPC commands transmitted in downlink

CFN	TPC commands in downlink
0	0 1 - - - - - 1 1 1 1 1 1
1	1 1 - - - - - 1 0 1 0 1 0
2	1 0 1 0 1 0 1 0 1 0 1 0 1

- 4) Measure the mean power in the following slots, not including the 25 μs transient periods at the start and end of each slot:

CFN 0: Slots # 9,10,11,12,13,14
 CFN 1: Slots # 0,1,9

- 5) Re-start the test. Before proceeding with step (7) below, set the output power of the UE to be in the range 2 ± 9 dBm. This may be achieved by setting the downlink signal (\hat{I}_{or}) to yield an appropriate open loop output power and/or by generating suitable downlink TPC commands from the SS.
- 6) Repeat step (2) above, with the exception that TGCFN = 3 in table 5.7.5 and table 5.7.9.
- 7) After the PHYSICAL CHANNEL RECONFIGURATION COMPLETE message from the UE is received, transmit TPC commands on the downlink as shown in table 5.7.7.

Table 5.7.7: TPC commands transmitted in downlink

CFN	TPC commands in downlink
3	0 1 - - - - - 0 0 0 0 0
4	0 0 - - - - - 0 1 0 1 0 1
5	0 1 0 1 0 1 0 1 0 1 0 1 0

- 8) Measure the mean power in the following slots, not including the 25 μ s transient periods at the start and end of each slot:
 - CFN 3: Slots # 9,10,11,12,13,14
 - CFN 4: Slots # 0,1,9
- 9) Re-start the test. Before proceeding with step (11) below, set the output power of the UE to be in the range -10 ± 9 dBm. This may be achieved by setting the downlink signal (\hat{I}_{or}) to yield an appropriate open loop output power and/or by generating suitable downlink TPC commands from the SS.
- 10) Transmit the PHYSICAL CHANNEL RECONFIGURATION message to set the uplink power control parameters to use Algorithm 1 and a step size of 1 dB, and to set the compressed mode parameters shown in table 5.7.8. The contents of the message are specified in table 5.7.10. This set of compressed mode parameters defines the compressed mode pattern which is used to test the implementation of power steps at the start and end of compressed frames, and the implementation of a zero power change when resuming transmission after a compressed mode gap.

Table 5.7.8: Parameters for pattern B for compressed mode test

Parameter	Meaning	Value
TGPRC	Number of transmission gap patterns within the Transmission Gap Pattern Sequence	1
TGCFN	Connection Frame Number of the first frame of the first pattern within the Transmission Gap Pattern Sequence	7
TGSN	Slot number of the first transmission gap slot within the TGCFN	8
TGL1	Length of first transmission gap within the transmission gap pattern	14 slots
TGL2	Length of second transmission gap within the transmission gap pattern	omit
TGD	Duration between the starting slots of two consecutive transmission gaps within a transmission gap pattern	UNDEFINED
TGPL1	Duration of transmission gap pattern 1	4 frames
TGPL2	Duration of transmission gap pattern 2	R99 and Rel-4: Omit Rel-5 and later releases: Not applicable
RPP	Recovery Period Power Control Mode	Mode 0
ITP	Initial Transmit Power Mode	Mode 0
UL/DL Mode	Defines whether UL only or combined UL/DL compressed mode is used	UL only or UL/DL
Downlink Compressed Mode Method	Method for generating downlink compressed mode gap	SF/2
Uplink Compressed Mode Method	Method for generating uplink compressed mode gap	SF/2
Scrambling code change	Indicates whether the alternative scrambling code is used	No code change
Downlink frame type	Downlink compressed frame structure	A
DeltaSIR	Delta in DL SIR target value to be set in the UE during compressed frames	0
DeltaSIRafter	Delta in DL SIR target value to be set in the UE one frame after the compressed frames	0

The resulting compressed mode pattern is shown in figure 5.7.3.

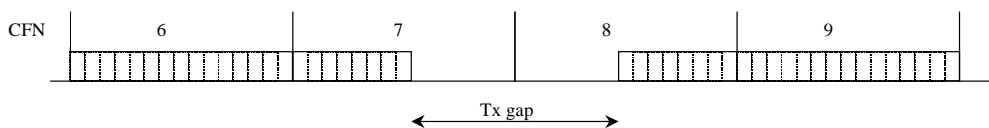

Figure 5.7.3: Pattern B for compressed mode test

- 11) After the PHYSICAL CHANNEL RECONFIGURATION COMPLETE message from the UE is received, transmit TPC commands on the downlink as shown in table 5.7.8.

Table 5.7.8: TPC commands transmitted in downlink

CFN	TPC commands in downlink
6	0 0 0 0 0 0 0 0 0 0 0 0 1 1 1
7	1 1 1 1 1 1 1 1 1 - - - - -
8	- - - - - 0 0 0 0 0 0 0
9	0 0 0 1 1 1 1 1 1 1 1 1 1 1 1

- 12) Measure the mean power in the following slots, not including the 25 μs transient periods at the start and end of each slot:

- CFN 6: Slot # 14
- CFN 7: Slots # 0 and 7
- CFN 8: Slots # 7 and 14
- CFN 9: Slot # 0

Table 5.7.9: PHYSICAL CHANNEL RECONFIGURATION message (step 2)

Information Element	Value/Remark	Version
Message Type		
UE Information Elements -RRC transaction identifier -Integrity check info - message authentication code - RRC message sequence number -Integrity protection mode info -Ciphering mode info -Activation time -New U-RNTI -New C-RNTI -RRC State Indicator -UTRAN DRX cycle length coefficient	0 SS calculates the value of MAC-I for this message and writes to this IE. The first/ leftmost bit of the bit string contains the most significant bit of the MAC-I. SS provides the value of this IE, from its internal counter. Not Present Not Present Not Present Not Present Not Present Not Present CELL_DCH Not Present	
CN Information Elements -CN Information info	Not Present	
UTRAN mobility information elements -URA identity	Not Present	
RB information elements -Downlink counter synchronisation info	Not Present	
PhyCH information elements -Frequency info	Not Present	
Uplink radio resources -Maximum allowed UL TX power -CHOICE channel requirement -Uplink DPCH power control info -CHOICE mode -DPCCH Power offset -PC Preamble -SRB delay -Power Control Algorithm -TPC step size -CHOICE mode -Scrambling code type -Scrambling code number -Number of DPDCH -spreading factor -TFCI existence -Number of FBI bits -Puncturing Limit	Not Present Uplink DPCH info FDD -40 (-80dB) 1 frame 7 frames Algorithm 1 2dB FDD Long 0 1 64 TRUE Not Present(0) 1	
Downlink radio resources -CHOICE mode -Downlink PDSCH information -Downlink information common for all radio links -Downlink DPCH info common for all RL -CHOICE mode -DPCH compressed mode info -Transmission gap pattern sequence -TGPSI -TGPS Status Flag -TGCFN -Transmission gap pattern sequence configuration parameters -TGMP -TGPRC -TGSN -TGL1 -TGL2 -TGD -TGPL1	FDD Not Present Not Present FDD 1 Activate 0 FDD measurement 1 2 7 7 15 3	R99 and Rel-4 only

-TGPL2	Not Present	R99 and Rel-4 only
-RPP	Mode 1	
-ITP	Mode 1	
-CHOICE UL/DL mode	UL only or UL and DL, depending on UE capability	
-Downlink compressed mode method	SF/2 or Not present depending on UE capability	
-Uplink compressed mode method	SF/2	
-Downlink frame type	A	
-DeltaSIR1	0	
-DeltaSIRafter1	0	
-DeltaSIR2	Not Present	
-DeltaSIRafter2	Not Present	
-N Identify abort	Not Present	
-T Reconfirm abort	Not Present	
-TX Diversity Mode	Not Present	
-SSDT information	Not Present	R99 and Rel-4 only
-Default DPCH Offset Value	Not Present	
-Downlink information per radio link list		
- Downlink information for each radio link		
-Choice mode	FDD	
-Primary CPICH info		
-Primary scrambling code	100	
-PDSCH with SHO DCH Info	Not Present	R99 and Rel-4 only
-PDSCH code mapping	Not Present	R99 and Rel-4 only
-Downlink DPCH info for each RL		
-CHOICE mode	FDD	
-Primary CPICH usage for channel estimation	Primary CPICH may be used	
-DPCH frame offset	Set to value Default DPCH Offset Value (as currently stored in SS) mod 38400	
-Secondary CPICH info	Not Present	
-DL channelisation code		
-Secondary scrambling code	Not Present	
-Spreading factor	128	
-Code number	96	
-Scrambling code change	No code change	
-TPC combination index	0	
-SSDT Cell Identity	Not Present	R99 and Rel-4 only
-Closed loop timing adjustment mode	Not Present	
-SCCPCH Information for FACH	Not Present	

-RPP	Mode 0	only
-ITP	Mode 0	
-CHOICE UL/DL mode	UL only or UL and DL, depending on UE capability	
-Downlink compressed mode method	SF/2 or Not present depending on UE capability	
-Uplink compressed mode method	SF/2	
-Downlink frame type	A	
-DeltaSIR1	0	
-DeltaSIRafter1	0	
-DeltaSIR2	Not Present	
-DeltaSIRafter2	Not Present	
-N Identify abort	Not Present	
-T Reconfirm abort	Not Present	
-TX Diversity Mode	Not Present	
-SSDT information	Not Present	R99 and Rel-4 only
-Default DPCH Offset Value	Not Present	
-Downlink information per radio link list		
- Downlink information for each radio link		
-Choice mode	FDD	
-Primary CPICH info		
-Primary scrambling code	100	
-PDSCH with SHO DCH Info	Not Present	R99 and Rel-4 only
-PDSCH code mapping	Not Present	R99 and Rel-4 only
-Downlink DPCH info for each RL		
-CHOICE mode	FDD	
-Primary CPICH usage for channel estimation	Primary CPICH may be used	
-DPCH frame offset	Set to value Default DPCH Offset Value (as currently stored in SS) mod 38400	
-Secondary CPICH info	Not Present	
-DL channelisation code		
-Secondary scrambling code	Not Present	
-Spreading factor	128	
-Code number	96	
-Scrambling code change	No code change	
-TPC combination index	0	
-SSDT Cell Identity	Not Present	R99 and Rel-4 only
-Closed loop timing adjustment mode	Not Present	
-SCCPCH Information for FACH	Not Present	

5.7.5 Test requirements

For ease of reference, the following uplink output power measurements are defined in figure 5.7.4. In this figure:

- P_g is the RRC filtered mean power in an uplink transmission gap, excluding the 25 μ s transient periods.
- P_a is the mean power in the last slot before a compressed frame (or pair of compressed frames), excluding the 25 μ s transient periods.
- P_b is the mean power in the first slot of a compressed frame, excluding the 25 μ s transient periods.
- P_c is the mean power in the last slot before a transmission gap, excluding the 25 μ s transient periods.
- P_d is the mean power in the first slot after a transmission gap, excluding the 25 μ s transient periods.
- P_e is the mean power in the last slot of a compressed frame, excluding the 25 μ s transient periods.
- P_f is the mean power in the first slot after a compressed frame (or pair of compressed frames), excluding the 25 μ s transient periods.

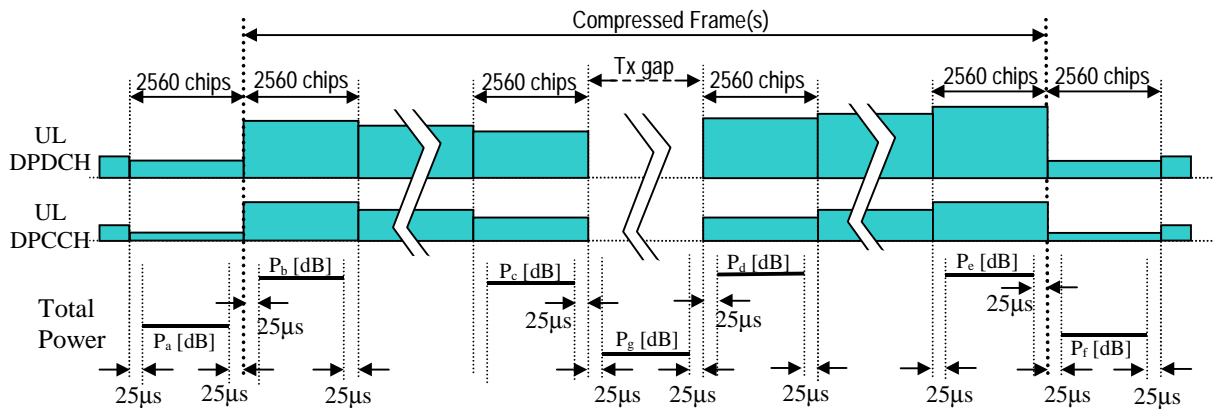

Figure 5.7.4: Uplink transmit power in uplink compressed mode

1. At the boundary between CFN 6 and CFN 7, $P_b - P_a$ shall be within the range $+4 \pm 2.3$ dB.
2. In slot #9 of CFN 1, the power difference $P_d - P_c$ from the power in slot #1 of CFN 1 shall be within the range -11 ± 4.3 dB.
3. In slot #9 of CFN 4, the power difference $P_d - P_c$ from the power in slot #1 of CFN 4 shall be within the range $+11 \pm 4.3$ dB.
4. In slot #7 of CFN 8, the power difference $P_d - P_c$ from the power in slot #7 of CFN 7 shall be within the range 0 ± 3.2 dB.
5. (void)
6. At the boundary between CFN 8 and CFN 9, $P_f - P_e$ shall be within the range -4 ± 2.3 dB.
7. In the slots between slot #10 of CFN 0 and slot #1 of CFN 1 inclusive, the change in mean power from the previous slot shall be within the range given in table 5.7. 11 for $TPC_cmd = +1$.
8. The aggregate change in mean power from slot #9 of CFN 0 to slot #1 of CFN 1 shall be within the range given in table 5.7. 12 for $TPC_cmd = +1$.
9. In the slots between slot #10 of CFN 3 and slot #1 of CFN 4 inclusive, the change in mean power from the previous slot shall be within the range given in table 5.7. 11 for $TPC_cmd = -1$.
10. The aggregate change in mean power from slot #9 of CFN 3 to slot #1 of CFN 4 shall be within the range given in table 5.7. 12 for $TPC_cmd = -1$.

Table 5.7.11: Transmitter power control range for 3dB step size

TPC_cmd	Transmitter power control range for 3dB step size	
	Lower	Upper
+1	+1,3 dB	+4,7 dB
0	-0,6 dB	+0,6 dB
-1	-1,3 dB	-4,7 dB

Table 5.7.12: Transmitter aggregate power control range for 3dB step size

TPC_cmd group	Transmitter power control range after 7 equal TPC_cmd groups	
	Lower	Upper
+1	+15,7dB	+26,3dB
0	-1,1dB	+1,1dB
-1	-15,7dB	-26,3dB

NOTE: If the above Test Requirement differs from the Minimum Requirement then the Test Tolerance applied for this test is non-zero. The Test Tolerance for this test is defined in clause F.2 and the explanation of how the Minimum Requirement has been relaxed by the Test Tolerance is given in clause F.4.

5.7A HS-DPCCH power control

5.7A.1 Definition and applicability

The transmission of Ack/Nack or CQI over the HS-DPCCH may cause the transmission power in the uplink to vary. The ratio of the amplitude between the DPCCH and the Ack/Nack and CQI respectively is signalled by higher layers.

The requirements and this test apply for Release 5 and later releases to all types of UTRA for the FDD UE that support HSDPA.

5.7A.2 Minimum requirement

The nominal sum power on DPCCH+DPDCH is independent of the transmission of Ack/Nack and CQI unless the UE output power when Ack/Nack or CQI is transmitted would exceed the maximum value specified in Table 5.2A.1 or fall below the value specified in 5.4.3.2, whereupon the UE may then also apply additional scaling to the total transmit power as defined in section 5.1.2.6 of TS.25.214 [5].

The composite transmitted power (DPCCH + DPDCH+HS-DPCCH) shall be rounded to the closest integer dB value. If rounding is done a power step exactly half-way between two integer values shall be rounded to the closest integer of greater magnitude.

The nominal power step due to transmission of Ack/Nack or CQI is defined as the difference between the nominal mean powers of two power evaluation periods either side of an HS-DPCCH boundary. The first evaluation period starts 25 μs after a DPCCH slot boundary and ends 25μs before the following HS-DPCCH slot boundary. The second evaluation period starts 25 μs after the same HS-DPCCH slot boundary and ends 25 μs before the following DPCCH slot boundary. This is described in figure 5.7A.1.

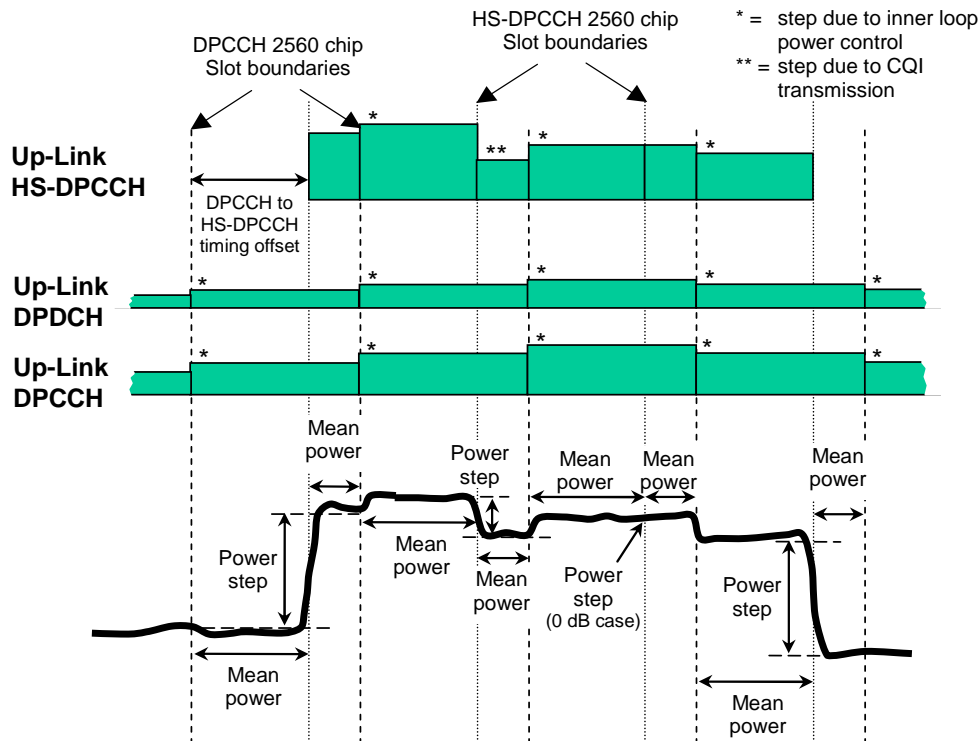

The power step due to HS-DPCCH transmission is the difference between the mean powers transmitted before and after an HS-DPCCH slot boundary. The mean power evaluation period excludes a 25μs period before and after any DPCCH or HS-DPCCH slot boundary.

Figure 5.7A.1: Transmit power template during HS-DPCCH transmission

The tolerance of the power step due to transmission of the HS-DPCCH shall meet the requirements in table 5.7A.1.

Table 5.7A.1: Transmitter power step tolerance

Power step size (Up or down) ΔP [dB]	Transmitter power step tolerance [dB]
0	+/- 0.5
1	+/- 0.5
2	+/- 1.0
3	+/- 1.5
$4 \leq \Delta P \leq 7$	+/- 2.0

The normative reference for this requirement is TS 25.101 [1] clause 6.5.5.1.

5.7A.3 Test purpose

To verify that the changes in uplink transmit power when transmitting the HS-DPCCH (Ack/Nack and CQI) and the power between HS-DPCCH transmissions are within the allowed power step tolerances as shown in table 5.7A.2 and 5.7A.3. The test is carried out at max power with TPC_cmd=1 and at a nominal power of 0 dBm at the minimum point of the 12ms transmit pattern (HS-DPCCH off).

5.7A.4 Method of test

5.7A.4.1 Initial conditions

Test environment: normal; see clauses G.2.1 and G.2.2.

Frequencies to be tested: mid range; see clause G.2.4.

- 1) Connect the SS (node B emulator) to the UE antenna connector as shown in figure A.1.
- 2) The UL Reference Measurement Channel and the Fixed Reference Channels (FRC H-Set 1, QPSK version) are specified in Annex C.10.1 and C.8.1.1.
- 3) An HSDPA call is set up according to TS 34.108 [3] clause 7.3.6. RF parameters are set up according to table E.5.1 and table E.5.10. Settings for the serving cell are defined in table 5.7A.1A.
- 4) Enter the UE into loopback test mode 1 in the presence of HSDPA and start the loopback test.

See TS 34.108 [3] and TS 34.109 [4] for details regarding loopback test mode for HSDPA.

Table 5.7A.1A: Settings for the serving cell during the measurement of HS-DPCCH

Parameter	Unit	Cell 1
Cell type		Serving cell
UTRA RF Channel Number		As defined in clause 5.7A.4.1
Qqualmin	dB	-24
Qrxlevmin	dBm	-115
UE_TXPWR_MAX_RACH	dBm	+21
\hat{I}_{or} (see notes 1 and 2)	dBm/3.84 MHz	-86
NOTE 1: The power level is specified in terms of \hat{I}_{or} instead of CPICH_RSCP because RSCP is a receiver measurement, whereas the SS can only set \hat{I}_{or} .		
NOTE 2: The cell fulfils TS 25.304, 5.2.3.1.2.		

5.7A.4.2 Procedure

- 1) Send TRANSPORT CHANNEL RECONFIGURATION message to set the beta values defined in table C.10.1.4 subtest 3 and the DPCH frame offset according the HS-DPCCH half slot offset required for measurements. This will create a signal with a repeat pattern of 12ms. The Uplink DPCH Power Control Info shall initially specify the Power Control Algorithm as algorithm 2 for interpreting TPC commands.

- 2) Generate suitable TPC commands from the SS to set the output power of the UE, measured at the UE antenna connector when the HS-DPCCH is not transmitted, to be in the range $0 \text{ dBm} \pm 2\text{dB}$. This is a nominal setting and not part of the test requirements.
- 5) Figure 5.7A.2 shows the 12ms cycle created when using the TRANSPORT CHANNEL RECONFIGURATION message from Annex I with the test specific message content defined below and with $\text{TPC_cmd}=0$. Measure the mean power during the half slot periods either side of the measurement points specified on figure 5.7A.2. The 25us transient periods at the end of each half slot period shall not be included. Measurement points 4, 8 and 11 are at the DPCCH slot boundaries just after and just before the HS-DPCCH transmission. Evaluate the difference in mean power to determine the power steps around the measurement points shown in Figure 5.7A.2. The power steps shall meet the test requirements in table 5.7A.2.
- 6) Reconfigure the uplink DPCCH power control Info to use Algorithm 1 with 1 dB step size. Set and send continuously Up power control commands to the UE until the UE output power during HS-DPCCH ACK/NACK transmission reaches the maximum as defined in table 5.2A.1.
- 7) Figure 5.7A.3 shows the 12ms cycle created when using $\text{TPC_cmd}=1$. Measure the mean power during the half slot periods either side of the measurement points specified on figure 5.7A.3. The 25us transient periods at the end of each half slot period shall not be included. Measurement points 5, 10 and 13 are at the DPCCH slot boundaries in between the HS-DPCCH transmissions. The last downward step prior to the HS-DPCCH transmission is not tested due to the accumulation of tolerances making the test requirement very wide. Evaluate the difference in mean power to determine the power steps around the measurement points shown in Figure 5.7A.3. The transmitter power steps shall meet the test requirements in table 5.7A.3.

Specific Message Contents

All messages indicated above shall use the same content as described in the default message content in clause 9 of TS 34.108 [3], except the TRANSPORT CHANNEL RECONFIGURATION message which is defined in Annex I. The test specific content for the TRANSPORT CHANNEL RECONFIGURATION message is as follows:

Information Element	Value/remark
- Ack-Nack repetition factor	1
- CQI repetition factor	1

5.7A.5 Test requirements

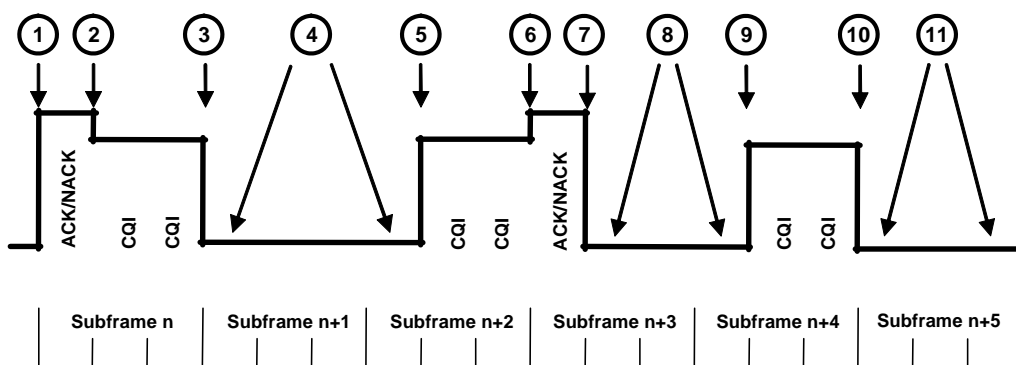

Figure 5.7A.2: Transmit power template below max power with $\text{TPC_cmd} = 0$

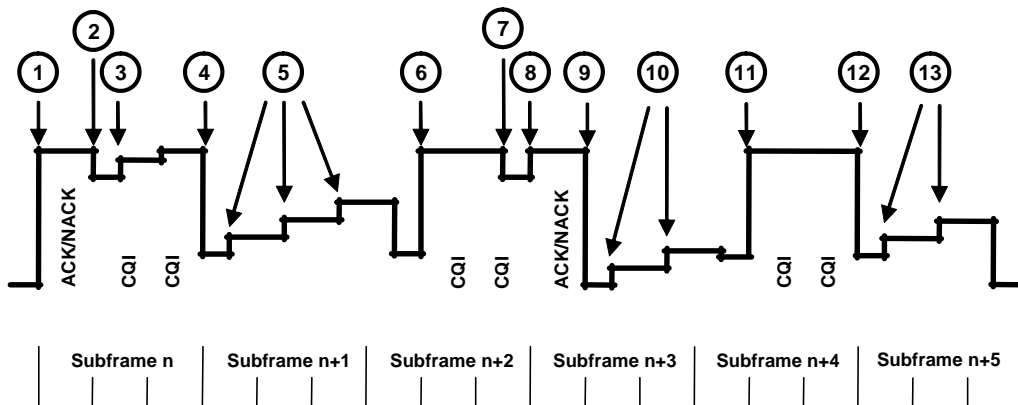

Figure 5.7A.3: Transmit power template at max power with TPC_cmd = 1

The difference in mean power derived in steps 5) and 7), shall not exceed the allowed transmitter power step range in table 5.7A.2 and 5.7A.3 respectively.

The UL reference measurement channel for TX test will be set as defined in C.10.1 with the power ratio between HS-DPCH, DPCCH and DPDCH being set to the values defined in table C.10.1.4 sub-test 3.

Table 5.7A.2: Transmitter power test requirements for TPC_cmd=0

Sub-test in table C.10.1.4	Power step	Nominal Power step size, ΔP [dB]	Rounded Power step size, ΔP [dB]	Transmitter power step Tolerance [dB]	Allowed Transmitter power step range [dB]
3	1	6.14	6	+/- 2.3	3.7 to 8.44
	2	-1.38	-1	+/- 0.6	-1.98 to -0.4
	3	-4.76	-5	+/- 2.3	-7.3 to -2.46
	4 ¹	0	0	+/- 0.6	-0.6 to 0.6
	5	4.76	5	+/- 2.3	2.46 to 7.3
	6	1.38	1	+/- 0.6	0.4 to 1.98
	7	-6.14	-6	+/- 2.3	-8.44 to -3.7
	8 ¹	0	0	+/- 0.6	-0.6 to 0.6
	9	4.76	5	+/- 2.3	2.46 to 7.3
	10	-4.76	-5	+/- 2.3	-7.3 to -2.46
	11 ¹	0	0	+/- 0.6	-0.6 to 0.6

Note 1: Two test points

Table 5.7A.3: Transmitter power test requirements for TPC_cmd=1

Sub-test in table C.10.1.4	Power step	Nominal Power step size, ΔP [dB]	Rounded Power step size, ΔP [dB]	Transmitter power step Tolerance [dB]	Allowed Transmitter power step range [dB]
3	1	6.14	6	+/- 2.3	3.7 to 8.44
	2	-1.38	-1	+/- 0.6	-1.98 to -0.4
	3	1	1	+/- 0.6	0.4 to 1.6
	4	-4.76	-5	+/- 2.3	-7.3 to -2.46
	5 ¹	1	1	+/- 0.6	0.4 to 1.6
	6	4.76	5	+/- 2.3	2.46 to 7.3
	7	-1.38	-1	+/- 0.6	-1.98 to -0.4
	8	1.38	1	+/- 0.6	0.40 to 1.98
	9	-6.14	-6	+/- 2.3	-8.44 to -3.7
	10 ²	1	1	+/- 0.6	0.4 to 1.6
	11	4.76	5	+/- 2.3	2.46 to 7.3
	12	-4.76	-5	+/- 2.3	-7.3 to -2.46
13 ²	1	1	+/- 0.6	0.4 to 1.6	
Note 1: Three test points					
Note 2: Two test points					

NOTE: If the above Test Requirement differs from the Minimum Requirement then the Test Tolerance applied for this test is non-zero. The Test Tolerance for this test is defined in clause F.2 and the explanation of how the Minimum Requirement has been relaxed by the Test Tolerance is given in clause F.4.

5.8 Occupied Bandwidth (OBW)

5.8.1 Definition and applicability

Occupied bandwidth is a measure of the bandwidth containing 99 % of the total integrated power of the transmitted spectrum, centred on the assigned channel frequency.

The requirements and this test apply to all types of UTRA for the FDD UE.

5.8.2 Minimum Requirements

The occupied channel bandwidth shall be less than 5 MHz based on a chip rate of 3,84 Mcps.

The normative reference for this requirement is TS 25.101 [1] clause 6.6.1.

5.8.3 Test purpose

To verify that the UE occupied channel bandwidth is less than 5 MHz based on a chip rate of 3,84 Mcps.

Excess occupied channel bandwidth increases the interference to other channels or to other systems.

5.8.4 Method of test

5.8.4.1 Initial conditions

Test environment: normal; see clauses G.2.1 and G.2.2.

Frequencies to be tested: low range, mid range, high range; see clause G.2.4.

- 1) Connect the SS to the UE antenna connector as shown in figure A.1.
- 2) A call is set up according to the Generic call setup procedure in TS34.108 [3] sub clause 7.3.2.
- 3) Enter the UE into loopback test mode and start the loopback test.

See TS 34.108 [3] and TS 34.109 [4] for details regarding generic call setup procedure and loopback test.

5.8.4.2 Procedure

- 1) Set and send continuously Up power control commands to the UE until the UE output power shall be maximum level.
- 2) Measure the power spectrum distribution within two times or more range over the requirement for Occupied Bandwidth specification centring on the current carrier frequency with 30 kHz or less RBW. The characteristic of the filter shall be approximately Gaussian (typical spectrum analyzer filter).
- 3) Calculate the total power within the range of all frequencies measured in '2)' and save this value as "Total Power".
- 4) Sum up the power upward from the lower boundary of the measured frequency range in '2)' and seek the limit frequency point by which this sum becomes 0,5 % of "Total Power" and save this point as "Lower Frequency".
- 5) Sum up the power downward from the upper boundary of the measured frequency range in '2)' and seek the limit frequency point by which this sum becomes 0,5 % of "Total Power" and save this point as "Upper Frequency".
- 6) Calculate the difference ("Upper Frequency" – "Lower Frequency" = "Occupied Bandwidth") between two limit frequencies obtained in '4)' and '5)'.

5.8.5 Test Requirements

The measured Occupied Bandwidth, derived in step 6), shall not exceed 5 MHz.

NOTE: If the above Test Requirement differs from the Minimum Requirement then the Test Tolerance applied for this test is non-zero. The Test Tolerance for this test is defined in clause F.2 and the explanation of how the Minimum Requirement has been relaxed by the Test Tolerance is given in clause F.4.

5.9 Spectrum emission mask

5.9.1 Definition and applicability

The spectrum emission mask of the UE applies to frequencies, which are between 2,5 MHz and 12,5 MHz away from the UE centre carrier frequency. The out of channel emission is specified relative to the RRC filtered mean power of the UE carrier.

The requirements and this test apply to all types of UTRA for the FDD UE.

5.9.2 Minimum Requirements

The power of any UE emission shall not exceed the levels specified in table 5.9.1.

The absolute requirement is based on a –50 dBm/3.84 MHz minimum power threshold for the UE. This limit is expressed for the narrower measurement bandwidths as –55.8 dBm/1 MHz and –71.1 dBm/30 kHz.

Table 5.9.1: Spectrum Emission Mask Requirement

Δf in MHz (Note 1)	Minimum requirement (Note 2)		Additional requirements Band II, IV, V, X (Note 3)	Measurement bandwidth (Note 6)
	Relative requirement	Absolute requirement		
2.5 - 3.5	$\left\{ -35 - 15 \cdot \left(\frac{\Delta f}{\text{MHz}} - 2.5 \right) \right\} \text{dBc}$	-71.1 dBm	-15 dBm	30 kHz (Note 4)
3.5 - 7.5	$\left\{ -35 - 1 \cdot \left(\frac{\Delta f}{\text{MHz}} - 3.5 \right) \right\} \text{dBc}$	-55.8 dBm	-13 dBm	1 MHz (Note 5)
7.5 - 8.5	$\left\{ -39 - 10 \cdot \left(\frac{\Delta f}{\text{MHz}} - 7.5 \right) \right\} \text{dBc}$	-55.8 dBm	-13 dBm	1 MHz (Note 5)
8.5 – 12.5 MHz	-49 dBc	-55.8 dBm	-13 dBm	1 MHz (Note 5)

Note 1: Δf is the separation between the carrier frequency and the centre of the measurement bandwidth.
Note 2: The minimum requirement is calculated from the relative requirement or the absolute requirement, whichever is the higher power.
Note 3: For operation in Band II, IV, V, X only, the minimum requirement is calculated from the minimum requirement calculated in Note 2 or the additional requirement for band II, whichever is the lower power.
Note 4: The first and last measurement position with a 30 kHz filter is at Δf equals to 2.515 MHz and 3.485 MHz.
Note 5: The first and last measurement position with a 1 MHz filter is at Δf equals to 4 MHz and 12 MHz.
Note 6: As a general rule, the resolution bandwidth of the measuring equipment should be equal to the measurement bandwidth. However, to improve measurement accuracy, sensitivity and efficiency, the resolution bandwidth may be smaller than the measurement bandwidth. When the resolution bandwidth is smaller than the measurement bandwidth, the result should be integrated over the measurement bandwidth in order to obtain the equivalent noise bandwidth of the measurement bandwidth.

The normative reference for this requirement is TS 25.101 [1] clause 6.6.2.1.1.

5.9.3 Test purpose

To verify that the power of UE emission does not exceed the prescribed limits shown in table 5.9.1.

Excess emission increases the interference to other channels or to other systems.

5.9.4 Method of test

5.9.4.1 Initial conditions

Test environment: normal; see clauses G.2.1 and G.2.2.

Frequencies to be tested: low range, mid range, high range; see clause G.2.4.

- 1) Connect the SS to the UE antenna connector as shown in figure A.1.
- 2) A call is set up according to the Generic call setup procedure in TS34.108 [3] sub clause 7.3.2.
- 3) Enter the UE into loopback test mode and start the loopback test.

See TS 34.108 [3] and TS 34.109 [4] for details regarding generic call setup procedure and loopback test.

5.9.4.2 Procedure

- 1) Set and send continuously Up power control commands to the UE until the UE output power shall be maximum level.
- 2) Measure the power of the transmitted signal with a measurement filter of bandwidths according to table 5.9.2. Measurements with an offset from the carrier centre frequency between 2,515 MHz and 3,485 MHz shall use a 30 kHz measurement filter. Measurements with an offset from the carrier centre frequency between 4 MHz and 12 MHz shall use 1 MHz measurement bandwidth and the result may be calculated by integrating multiple 50 kHz or narrower filter measurements. The characteristic of the filter shall be approximately Gaussian (typical

spectrum analyzer filter). The centre frequency of the filter shall be stepped in contiguous steps according to table 5.9.2. The measured power shall be recorded for each step.

- 3) Measure the RRC filtered mean power centered on the assigned channel frequency.
- 4) Calculate the ratio of the power 2) with respect to 3) in dBc.

5.9.5 Test requirements

The result of clause 5.9.4.2 step 4) shall fulfil the requirements of table 5.9.2.

Table 5.9.2: Spectrum Emission Mask Requirement

Δf in MHz (Note 1)	Minimum requirement (Note 2)		Additional requirements Band II, IV, V, X (Note 3)	Measurement bandwidth (Note 6)
	Relative requirement	Absolute requirement (in measurement band width)		
2.5 - 3.5	$\left\{ -33.5 - 15 \cdot \left(\frac{\Delta f}{\text{MHz}} - 2.5 \right) \right\} \text{dBc}$	-69.6 dBm	-15 dBm	30 kHz (Note 4)
3.5 - 7.5	$\left\{ -33.5 - 1 \cdot \left(\frac{\Delta f}{\text{MHz}} - 3.5 \right) \right\} \text{dBc}$	-54.3 dBm	-13 dBm	1 MHz (Note 5)
7.5 - 8.5	$\left\{ -37.5 - 10 \cdot \left(\frac{\Delta f}{\text{MHz}} - 7.5 \right) \right\} \text{dBc}$	-54.3 dBm	-13 dBm	1 MHz (Note 5)
8.5 - 12.5 MHz	-47.5 dBc	-54.3 dBm	-13 dBm	1 MHz (Note 5)

Note 1: Δf is the separation between the carrier frequency and the centre of the measurement bandwidth.
 Note 2: The minimum requirement is calculated from the relative requirement or the absolute requirement, whichever is the higher power.
 Note 3: For operation in Band II, IV, V, X only, the minimum requirement is calculated from the minimum requirement calculated in Note 2 or the additional requirement for band II, whichever is the lower power.
 Note 4: The first and last measurement position with a 30 kHz filter is at Δf equals to 2.515 MHz and 3.485 MHz.
 Note 5: The first and last measurement position with a 1 MHz filter is at Δf equals to 4 MHz and 12 MHz.
 Note 6: As a general rule, the resolution bandwidth of the measuring equipment should be equal to the measurement bandwidth. However, to improve measurement accuracy, sensitivity and efficiency, the resolution bandwidth may be smaller than the measurement bandwidth. When the resolution bandwidth is smaller than the measurement bandwidth, the result should be integrated over the measurement bandwidth in order to obtain the equivalent noise bandwidth of the measurement bandwidth.

NOTE: If the above Test Requirement differs from the Minimum Requirement then the Test Tolerance applied for this test is non-zero. The Test Tolerance for this test is defined in clause F.2 and the explanation of how the Minimum Requirement has been relaxed by the Test Tolerance is given in clause F.4.

5.9A Spectrum Emission Mask with HS-DPCCH

5.9A.1 Definition and applicability

The spectrum emission mask of the UE applies to frequencies, which are between 2,5 MHz and 12,5 MHz away from the UE centre carrier frequency. The out of channel emission is specified relative to the RRC filtered mean power of the UE carrier.

The requirements and this test apply for Release 5 and later releases to all types of UTRA for the FDD UE that support HSDPA.

5.9A.2 Minimum Requirements

The power of any UE emission shall not exceed the levels specified in table 5.9A.1. The absolute requirement is based on a -50 dBm/3.84 MHz minimum power threshold for the UE. This limit is expressed for the narrower measurement bandwidths as -55.8 dBm/1 MHz and -71.1 dBm/30 kHz. This is applicable for all values of β_c , β_d and β_{hs} as specified in [5].

Table 5.9A.1: Spectrum Emission Mask Requirement

Δf in MHz (Note 1)	Minimum requirement (Note 2)		Additional requirements Band II, IV, V, X (Note 3)	Measurement bandwidth (Note 6)
	Relative requirement	Absolute requirement		
2.5 to 3.5	$\left\{ -35 - 15 \cdot \left(\frac{\Delta f}{\text{MHz}} - 2.5 \right) \right\} \text{dBc}$	-71.1 dBm	-15 dBm	30 kHz (Note 4)
3.5 to 7.5	$\left\{ -35 - 1 \cdot \left(\frac{\Delta f}{\text{MHz}} - 3.5 \right) \right\} \text{dBc}$	-55.8 dBm	-13 dBm	1 MHz (Note 5)
7.5 to 8.5	$\left\{ -39 - 10 \cdot \left(\frac{\Delta f}{\text{MHz}} - 7.5 \right) \right\} \text{dBc}$	-55.8 dBm	-13 dBm	1 MHz (Note 5)
8.5 to 12.5 MHz	-49 dBc	-55.8 dBm	-13 dBm	1 MHz (Note 5)

Note 1: Δf is the separation between the carrier frequency and the centre of the measurement bandwidth.
 Note 2: The minimum requirement is calculated from the relative requirement or the absolute requirement, whichever is the higher power.
 Note 3: For operation in Band II, IV, V, X only, the minimum requirement is calculated from the minimum requirement calculated in Note 2 or the additional requirement for band II, whichever is the lower power.
 Note 4: The first and last measurement position with a 30 kHz filter is at Δf equals to 2.515 MHz and 3.485 MHz.
 Note 5: The first and last measurement position with a 1 MHz filter is at Δf equals to 4 MHz and 12 MHz.
 Note 6: As a general rule, the resolution bandwidth of the measuring equipment should be equal to the measurement bandwidth. However, to improve measurement accuracy, sensitivity and efficiency, the resolution bandwidth may be smaller than the measurement bandwidth. When the resolution bandwidth is smaller than the measurement bandwidth, the result should be integrated over the measurement bandwidth in order to obtain the equivalent noise bandwidth of the measurement bandwidth.

The normative reference for this requirement is TS 25.101 [1] clause 6.6.2.1.1.

5.9A.3 Test purpose

To verify that the power of UE emission does not exceed the prescribed limits shown in table 5.9A.1. even in the presence of the HS-DPCCH. (see note). This is applicable for all values of β_c , β_d and β_{hs} as specified in [5]. The maximum output power with HS-DPCCH is specified in table 5.2A.1.

Excess emission increases the interference to other channels or to other systems.

Note: For a static signal, the measurement with a 1MHz filter can be replaced by a narrower filter and integration over the bandwidth. (Note 6 in table 5.9A.1) For a non static signal the above described replacement gives different results, depending on the type of dynamic in the signal and depending on the bandwidth of the filter. Hence the signal is tested only when static.

5.9A.4 Method of test

5.9A.4.1 Initial conditions

Test environment: normal; see clauses G.2.1 and G.2.2.

Frequencies to be tested: low range, mid range, high range; see clause G.2.4.

1) Connect the SS (node B emulator) to the UE antenna connector as shown in figure A.1.

- 2) The UL Reference Measurement Channel and the Fixed Reference Channels (FRC H-Set 1, QPSK version) are specified in Annex C.10.1 and C.8.1.1.
- 3) An HSDPA call is set up according to TS 34.108 [3] clause 7.3.6. RF parameters are set up according to table E.5.1 and table E.5.10. Settings for the serving cell are defined in table 5.9A.2.
- 4) Enter the UE into loopback test mode in the presence of HSDPA and start the loopback test.

See TS 34.108 [3] and TS 34.109 [4] for details regarding loopback test mode for HSDPA.

Table 5.9A.2: Settings for the serving cell during the measurement of Spectrum Emission Mask with HS-DPCCH

Parameter	Unit	Cell 1
Cell type		Serving cell
UTRA RF Channel Number		As defined in clause 5.9A.4.1
Qqualmin	dB	-24
Qrxlevmin	dBm	-115
UE_TXPWR_MAX_RACH	dBm	+21
I_{or} (see notes 1 and 2)	dBm/3.84 MHz	-86
NOTE 1: The power level is specified in terms of I_{or} instead of CPICH_RSCP because RSCP is a receiver measurement, whereas the SS can only set I_{or} .		
NOTE 2: The cell fulfils TS 25.304, 5.2.3.1.2.		

5.9A.4.2 Procedure

- 1) Send TRANSPORT CHANNEL RECONFIGURATION message to set the beta values according to table C.10.1.4 and the DPCH frame offset according the HS-DPCCH slot offset required for measurements.
- 2) Set and send continuously Up power control commands to the UE.
- 3) Start transmitting HSDPA Data.
- 4) When UE has reached the maximum power, measure the power of the transmitted signal with a measurement filter of bandwidths according to table 5.9A.3. Measurements with an offset from the carrier centre frequency between 2,515 MHz and 3,485 MHz shall use a 30 kHz measurement filter. Measurements with an offset from the carrier centre frequency between 4 MHz and 12 MHz shall use 1 MHz measurement bandwidth and the result may be calculated by integrating multiple 50 kHz or narrower filter (≥ 3 kHz) measurements. The characteristic of the filter shall be approximately Gaussian (typical spectrum analyzer filter). The centre frequency of the filter shall be stepped in contiguous steps according to table 5.9A.3. The measured power shall be recorded for each step. The measurement duration with the filter on one frequency shall last at least the filter settling time and the measurement period shall be inside the HS-DPCCH on-period.
- 5) Measure the RRC filtered mean power centered on the assigned channel frequency.
- 6) Calculate the ratio of the power 4) with respect to 5) in dBc.
- 7) Repeat steps 1-6 for all the different combinations of beta values as given in table C.10.1.4.

All messages indicated above shall use the same content as described in the default message content in clause 9 of TS 34.108 [3], except the TRANSPORT CHANNEL RECONFIGURATION message which is defined in Annex I.

5.9A.5 Test requirements

The result of clause 5.9A.4.2 step 6) shall fulfil the requirements of table 5.9A.3.

Table 5.9A.3: Spectrum Emission Mask Requirement

Δf in MHz (Note 1)	Minimum requirement (Note 2)		Additional requirements Band II, IV, V, X (Note 3)	Measurement bandwidth (Note 6)
	Relative requirement	Absolute requirement		
2.5 to 3.5	$\left\{ -33.5 - 15 \cdot \left(\frac{\Delta f}{\text{MHz}} - 2.5 \right) \right\} \text{dBc}$	-69.6 dBm	-15 dBm	30 kHz (Note 4)
3.5 to 7.5	$\left\{ -33.5 - 1 \cdot \left(\frac{\Delta f}{\text{MHz}} - 3.5 \right) \right\} \text{dBc}$	-54.3 dBm	-13 dBm	1 MHz (Note 5)
7.5 to 8.5	$\left\{ -37.5 - 10 \cdot \left(\frac{\Delta f}{\text{MHz}} - 7.5 \right) \right\} \text{dBc}$	-54.3 dBm	-13 dBm	1 MHz (Note 5)
8.5 to 12.5 MHz	-47.5 dBc	-54.3 dBm	-13 dBm	1 MHz (Note 5)
<p>Note 1: Δf is the separation between the carrier frequency and the centre of the measurement bandwidth.</p> <p>Note 2: The minimum requirement is calculated from the relative requirement or the absolute requirement, whichever is the higher power.</p> <p>Note 3: For operation in Band II, IV, V, X only, the minimum requirement is calculated from the minimum requirement calculated in Note 2 or the additional requirement for band II, whichever is the lower power.</p> <p>Note 4: The first and last measurement position with a 30 kHz filter is at Δf equals to 2.515 MHz and 3.485 MHz.</p> <p>Note 5: The first and last measurement position with a 1 MHz filter is at Δf equals to 4 MHz and 12 MHz.</p> <p>Note 6: As a general rule, the resolution bandwidth of the measuring equipment should be equal to the measurement bandwidth. However, to improve measurement accuracy, sensitivity and efficiency, the resolution bandwidth may be smaller than the measurement bandwidth. When the resolution bandwidth is smaller than the measurement bandwidth, the result should be integrated over the measurement bandwidth in order to obtain the equivalent noise bandwidth of the measurement bandwidth.</p>				

NOTE: If the above Test Requirement differs from the Minimum Requirement then the Test Tolerance applied for this test is non-zero. The Test Tolerance for this test is defined in clause F.2 and the explanation of how the Minimum Requirement has been relaxed by the Test Tolerance is given in clause F.4.

5.9B Spectrum Emission Mask with E-DCH

5.9B.1 Definition and applicability

The spectrum emission mask of the UE applies to frequencies, which are between 2,5 MHz and 12,5 MHz away from the UE centre carrier frequency. The out of channel emission is specified relative to the RRC filtered mean power of the UE carrier.

The requirements and this test apply for Release 6 and later releases to all types of UTRA for the FDD UE that support HSDPA and E-DCH.

5.9B.2 Minimum Requirements

The power of any UE emission shall not exceed the levels specified in table 5.9B.1. The absolute requirement is based on a -50 dBm/3.84 MHz minimum power threshold for the UE. This limit is expressed for the narrower measurement bandwidths as -55.8 dBm/1 MHz and -71.1 dBm/30 kHz. This is applicable for all values of β_c , β_d , β_{hs} , β_{ec} and β_{ed} as specified in [5].

Table 5.9B.1: Spectrum Emission Mask Requirement

Δf in MHz (Note 1)	Minimum requirement (Note 2)		Additional requirements Band II, IV, V, X (Note 3)	Measurement bandwidth (Note 6)
	Relative requirement	Absolute requirement		
2.5 to 3.5	$\left\{ -35 - 15 \cdot \left(\frac{\Delta f}{\text{MHz}} - 2.5 \right) \right\} \text{dBc}$	-71.1 dBm	-15 dBm	30 kHz (Note 4)
3.5 to 7.5	$\left\{ -35 - 1 \cdot \left(\frac{\Delta f}{\text{MHz}} - 3.5 \right) \right\} \text{dBc}$	-55.8 dBm	-13 dBm	1 MHz (Note 5)
7.5 to 8.5	$\left\{ -39 - 10 \cdot \left(\frac{\Delta f}{\text{MHz}} - 7.5 \right) \right\} \text{dBc}$	-55.8 dBm	-13 dBm	1 MHz (Note 5)
8.5 to 12.5 MHz	-49 dBc	-55.8 dBm	-13 dBm	1 MHz (Note 5)
<p>Note 1: Δf is the separation between the carrier frequency and the centre of the measurement bandwidth.</p> <p>Note 2: The minimum requirement is calculated from the relative requirement or the absolute requirement, whichever is the higher power.</p> <p>Note 3: For operation in Band II, IV, V, X only, the minimum requirement is calculated from the minimum requirement calculated in Note 2 or the additional requirement for band II, whichever is the lower power.</p> <p>Note 4: The first and last measurement position with a 30 kHz filter is at Δf equals to 2.515 MHz and 3.485 MHz.</p> <p>Note 5: The first and last measurement position with a 1 MHz filter is at Δf equals to 4 MHz and 12 MHz.</p> <p>Note 6: As a general rule, the resolution bandwidth of the measuring equipment should be equal to the measurement bandwidth. However, to improve measurement accuracy, sensitivity and efficiency, the resolution bandwidth may be smaller than the measurement bandwidth. When the resolution bandwidth is smaller than the measurement bandwidth, the result should be integrated over the measurement bandwidth in order to obtain the equivalent noise bandwidth of the measurement bandwidth.</p>				

The normative reference for this requirement is TS 25.101 [1] clause 6.6.2.1.1.

5.9B.3 Test purpose

To verify that the power of UE emission does not exceed the prescribed limits shown in table 5.9B.1. even in the presence of the E-DCH. (see note). This is applicable for all values of β_c , β_d , β_{hs} , β_{ec} and β_{ed} as specified in [5]. The maximum output power with HS-DPCCH and/or E-DCH is specified in table 5.2B.1.

Excess emission increases the interference to other channels or to other systems.

Note: For a static signal, the measurement with a 1MHz filter can be replaced by a narrower filter and integration over the bandwidth. (Note 6 in table 5.9B.1) For a non static signal the above described replacement gives different results, depending on the type of dynamic in the signal and depending on the bandwidth of the filter. Hence the signal is tested only when static.

5.9B.4 Method of test

5.9B.4.1 Initial conditions

Test environment: normal; see clauses G.2.1 and G.2.2.

Frequencies to be tested: low range, mid range, high range; see clause G.2.4.

- 1) Connect the SS (node B emulator) to the UE antenna connector as shown in figure A.1.
- 2) The UL Reference Measurement Channel and the Fixed Reference Channels (FRC H-Set 1, QPSK) are specified in Annex C.11.1 and C.8.1.1.
- 3) An E-DCH call is set up according to TS 34.108 [3] 7.3.9 with the exceptions in the RADIO BEARER SETUP messages as given in Tables 5.2B.1A, 5.2B.2, 5.2B3 and 5.2B.4. These exceptions allow the beta values to be set according to table C.11.1.3 and each UL physical channel to be at constant power during the measurement. RF parameters are set up according to table E.5A.1. Settings for the serving cell are defined in table 5.9B.2.

- 4) Enter the UE into loopback test mode 1 looping back both the 12.2kbps RMC and HSDPA to E-DCH, and start the loopback test.

See TS 34.109 [4] clauses 5.3.2.3 and 5.3.2.6 for details regarding loopback test mode for HSDPA and E-DCH.

Table 5.9B.2: Settings for the serving cell during the measurement of Spectrum Emission Mask with E-DCH

Parameter	Unit	Cell 1
Cell type		Serving cell
UTRA RF Channel Number		As defined in clause 5.9B.4.1
Qqualmin	dB	-24
Qrxlevmin	dBm	-115
UE_TXPWR_MAX_RACH	dBm	+21
I_{or} (see notes 1 and 2)	dBm/3.84 MHz	-86
NOTE 1: The power level is specified in terms of I_{or} instead of CPICH_RSCP because RSCP is a receiver measurement, whereas the SS can only set I_{or} .		
NOTE 2: The cell fulfils TS 25.304, 5.2.3.1.2.		

5.9B.4.2 Procedure

- 1) Set UE to maximum output power according to 5.2B.4.2 steps 1 to 8.
- 2) When UE has reached the maximum power, measure the power of the transmitted signal with a measurement filter of bandwidths according to table 5.9B.3. Measurements with an offset from the carrier centre frequency between 2,515 MHz and 3,485 MHz shall use a 30 kHz measurement filter. Measurements with an offset from the carrier centre frequency between 4 MHz and 12 MHz shall use 1 MHz measurement bandwidth and the result may be calculated by integrating multiple 50 kHz or narrower filter (≥ 3 kHz) measurements. The characteristic of the filter shall be approximately Gaussian (typical spectrum analyzer filter). The centre frequency of the filter shall be stepped in contiguous steps according to table 5.9B.3. The measured power shall be recorded for each step. The measurement duration with the filter on one frequency shall last at least the filter settling time and the measurement period shall be inside the HS-DPCCH on-period.
- 3) Measure the RRC filtered mean power centered on the assigned channel frequency.
- 4) Calculate the ratio of the power 2) with respect to 3) in dBc.
- 5) Repeat steps 1-4 for all the different combinations of beta values as given in table C.11.1.3.

5.9B.5 Test requirements

The result of clause 5.9B.4.2 step 4) shall fulfil the requirements of table 5.9B.3.

Table 5.9B.3: Spectrum Emission Mask Requirement

Δf in MHz (Note 1)	Minimum requirement (Note 2)		Additional requirements Band II, IV, V, X (Note 3)	Measurement bandwidth (Note 6)
	Relative requirement	Absolute requirement		
2.5 to 3.5	$\left\{ -33.5 - 15 \cdot \left(\frac{\Delta f}{\text{MHz}} - 2.5 \right) \right\} \text{dBc}$	-69.6 dBm	-15 dBm	30 kHz (Note 4)
3.5 to 7.5	$\left\{ -33.5 - 1 \cdot \left(\frac{\Delta f}{\text{MHz}} - 3.5 \right) \right\} \text{dBc}$	-54.3 dBm	-13 dBm	1 MHz (Note 5)
7.5 to 8.5	$\left\{ -37.5 - 10 \cdot \left(\frac{\Delta f}{\text{MHz}} - 7.5 \right) \right\} \text{dBc}$	-54.3 dBm	-13 dBm	1 MHz (Note 5)
8.5 to 12.5 MHz	-47.5 dBc	-54.3 dBm	-13 dBm	1 MHz (Note 5)

Note 1: Δf is the separation between the carrier frequency and the centre of the measurement bandwidth.
Note 2: The minimum requirement is calculated from the relative requirement or the absolute requirement, whichever is the higher power.
Note 3: For operation in Band II, IV, V, X only, the minimum requirement is calculated from the minimum requirement calculated in Note 2 or the additional requirement for band II, whichever is the lower power.
Note 4: The first and last measurement position with a 30 kHz filter is at Δf equals to 2.515 MHz and 3.485 MHz.
Note 5: The first and last measurement position with a 1 MHz filter is at Δf equals to 4 MHz and 12 MHz.
Note 6: As a general rule, the resolution bandwidth of the measuring equipment should be equal to the measurement bandwidth. However, to improve measurement accuracy, sensitivity and efficiency, the resolution bandwidth may be smaller than the measurement bandwidth. When the resolution bandwidth is smaller than the measurement bandwidth, the result should be integrated over the measurement bandwidth in order to obtain the equivalent noise bandwidth of the measurement bandwidth.

NOTE: If the above Test Requirement differs from the Minimum Requirement then the Test Tolerance applied for this test is non-zero. The Test Tolerance for this test is defined in clause F.2 and the explanation of how the Minimum Requirement has been relaxed by the Test Tolerance is given in clause F.4.

5.10 Adjacent Channel Leakage Power Ratio (ACLR)

5.10.1 Definition and applicability

ACLR is the ratio of the RRC filtered mean power centred on the assigned channel frequency to the RRC filtered mean power centred on an adjacent channel frequency.

The requirements and this test apply to all types of UTRA for the FDD UE.

5.10.2 Minimum Requirements

If the adjacent channel RRC filtered mean power is greater than -50dBm then the ACLR shall be higher than the value specified in table 5.10.1.

Table 5.10.1: UE ACLR

Power Class	UE channel	ACLR limit
3	+5 MHz or -5 MHz	33 dB
3	+10 MHz or -10 MHz	43 dB
4	+5 MHz or -5 MHz	33 dB
4	+10 MHz or -10 MHz	43 dB

NOTE 1: The requirement shall still be met in the presence of switching transients.

NOTE 2: The ACLR requirements reflect what can be achieved with present state of the art technology.

NOTE 3: Requirement on the UE shall be reconsidered when the state of the art technology progresses.

The normative reference for this requirement is TS 25.101 [1] clause 6.6.2.2.1.

5.10.3 Test purpose

To verify that the UE ACLR does not exceed prescribed limit shown in table 5.10.1.

Excess ACLR increases the interference to other channels or to other systems.

5.10.4 Method of test

5.10.4.1 Initial conditions

Test environment: normal, TL/VL, TL/VH, TH/VL, TH/VH; see clauses G.2.1 and G.2.2.

Frequencies to be tested: low range, mid range, high range; see clause G.2.4.

- 1) Connect the SS to the UE antenna connector as shown in figure A.1.
- 2) A call is set up according to the Generic call setup procedure in TS34.108 [3] sub clause 7.3.2.
- 3) Enter the UE into loopback test mode and start the loopback test.

See TS 34.108 [3] and TS 34.109 [4] for details regarding generic call setup procedure and loopback test.

5.10.4.2 Procedure

- 1) Set and send continuously Up power control commands to the UE until the UE output power shall be maximum level.
- 2) Measure the RRC filtered mean power.
- 3) Measure the RRC filtered mean power of the first adjacent channels and the second adjacent channels.
- 4) Calculate the ratio of the power between the values measured in '2)' and '3)'.

5.10.5 Test requirements

If the measured adjacent channel RRC filtered mean power, derived in step 3), is greater than $-50,0$ dBm then the measured ACLR, derived in step 4), shall be higher than the limit in table 5.10.2.

Table 5.10.2: UE ACLR

Power Class	UE channel	ACLR limit
3	+5 MHz or -5 MHz	32,2 dB
3	+10 MHz or -10 MHz	42,2 dB
4	+5 MHz or -5 MHz	32,2 dB
4	+10 MHz or -10 MHz	42,2 dB

NOTE 1: The requirement shall still be met in the presence of switching transients.

NOTE 2: The ACLR requirements reflect what can be achieved with present state of the art technology.

NOTE 3: Requirement on the UE shall be reconsidered when the state of the art technology progresses.

NOTE 4: If the above Test Requirement differs from the Minimum Requirement then the Test Tolerance applied for this test is non-zero. The Test Tolerance for this test is defined in clause F.2 and the explanation of how the Minimum Requirement has been relaxed by the Test Tolerance is given in clause F.4.

5.10A Adjacent Channel Leakage Power Ratio (ACLR) with HS-DPCCH

5.10A.1 Definition and applicability

ACLR is the ratio of the RRC filtered mean power centred on the assigned channel frequency to the RRC filtered mean power centred on an adjacent channel frequency.

The requirements and this test apply for Release 5 and later releases to all types of UTRA for the FDD UE that support HSDPA.

5.10A.2 Minimum Requirements

If the adjacent channel RRC filtered mean power is greater than -50 dBm then the ACLR shall be higher than the value specified in table 5.10A.1. This is applicable for all values of β_c , β_d and β_{hs} as specified in [5].

Table 5.10A.1: UE ACLR

Power Class	UE channel	ACLR limit
3	+5 MHz or -5 MHz	33 dB
3	+10 MHz or -10 MHz	43 dB
4	+5 MHz or -5 MHz	33 dB
4	+10 MHz or -10 MHz	43 dB

NOTE 1: The requirement shall still be met in the presence of switching transients.

NOTE 2: The ACLR requirements reflect what can be achieved with present state of the art technology.

NOTE 3: Requirement on the UE shall be reconsidered when the state of the art technology progresses.

The normative reference for this requirement is TS 25.101 [1] clause 6.6.2.2.1.

5.10A.3 Test purpose

To verify that the UE ACLR does not exceed prescribed limit shown in table 5.10A.1. This is applicable for all values of β_c , β_d and β_{hs} as specified in [5]. The maximum output power with HS-DPCCH is specified in table 5.2A.1.

Excess ACLR increases the interference to other channels or to other systems.

5.10A.4 Method of test

5.10A.4.1 Initial conditions

Test environment: normal, TL/VL, TL/VH, TH/VL, TH/VH; see clauses G.2.1 and G.2.2.

Frequencies to be tested: low range, mid range, high range; see clause G.2.4.

- 1) Connect the SS (node B emulator) to the UE antenna connector as shown in figure A.1.
- 2) The UL Reference Measurement Channel and the Fixed Reference Channels (FRC H-Set 1, QPSK version) are specified in Annex C.10.1 and C.8.1.1.
- 3) An HSDPA call is set up according to TS 34.108 [3] clause 7.3.6. RF parameters are set up according to table E.5.1 and table E.5.10. Settings for the serving cell are defined in table 5.10A.2.
- 4) Enter the UE into loopback test mode in the presence of HSDPA and start the loopback test.

See TS 34.108 [3] and TS 34.109 [4] for details regarding loopback test mode for HSDPA.

Table 5.10A.2: Settings for the serving cell during the measurement of Adjacent Channel Leakage Power Ratio (ACLR) with HS-DPCCH

Parameter	Unit	Cell 1
Cell type		Serving cell
UTRA RF Channel Number		As defined in clause 5.10A.4.1
Qqualmin	dB	-24
Qrxlevmin	dBm	-115
UE_TXPWR_MAX_RACH	dBm	+21
\hat{I}_{or} (see notes 1 and 2)	dBm/3.84 MHz	-86
NOTE 1: The power level is specified in terms of \hat{I}_{or} instead of CPICH_RSCP because RSCP is a receiver measurement, whereas the SS can only set \hat{I}_{or} .		
NOTE 2: The cell fulfils TS 25.304, 5.2.3.1.2.		

5.10A.4.2 Procedure

- 1) Send TRANSPORT CHANNEL RECONFIGURATION message to set the beta values according to table C.10.1.4 and the DPCH frame offset according the HS-DPCCH slot offset required for measurements.
- 2) Set and send continuously Up power control commands to the UE.
- 3) Start transmitting HSDPA Data.
- 4) When UE has reached the maximum power, measure the RRC filtered mean power on the wanted channel. The measurement period shall be inside the HS-DPCCH on-period for the wanted and the adjacent channels.
- 5) Measure the RRC filtered mean power of the first adjacent channels and the second adjacent channels.
- 6) Calculate the ratio of the power between the values measured in step 4) and step 5).
- 7) Repeat steps 1-6 for all the different combinations of beta values as given in table C.10.1.4.

All messages indicated above shall use the same content as described in the default message content in clause 9 of TS 34.108 [3], except the TRANSPORT CHANNEL RECONFIGURATION message which is defined in Annex I.

5.10A.5 Test requirements

The measured ACLR, derived in step 6), shall be higher than the limit in table 5.10A.3.

Table 5.10A.3: UE ACLR

Power Class	UE channel	ACLR limit
3	+5 MHz or -5 MHz	32.2 dB
3	+10 MHz or -10 MHz	42.2 dB
4	+5 MHz or -5 MHz	32.2 dB
4	+10 MHz or -10 MHz	42.2 dB

NOTE: If the above Test Requirement differs from the Minimum Requirement then the Test Tolerance applied for this test is non-zero. The Test Tolerance for this test is defined in clause F.2 and the explanation of how the Minimum Requirement has been relaxed by the Test Tolerance is given in clause F.4.

5.10B Adjacent Channel Leakage Power Ratio (ACLR) with E-DCH

5.10B.1 Definition and applicability

ACLR is the ratio of the RRC filtered mean power centred on the assigned channel frequency to the RRC filtered mean power centred on an adjacent channel frequency.

The requirements and this test apply for Release 6 and later releases to all types of UTRA for the FDD UE that support HSDPA and E-DCH.

5.10B.2 Minimum Requirements

If the adjacent channel RRC filtered mean power is greater than -50dBm then the ACLR shall be higher than the value specified in table 5.10B.1. This is applicable for all values of β_c , β_d , β_{hs} , β_{ec} and β_{ed} as specified in [5].

Table 5.10B.1: UE ACLR

Power Class	UE channel	ACLR limit
3	+5 MHz or -5 MHz	33 dB
3	+10 MHz or -10 MHz	43 dB
4	+5 MHz or -5 MHz	33 dB
4	+10 MHz or -10 MHz	43 dB

NOTE 1: The requirement shall still be met in the presence of switching transients.

NOTE 2: The ACLR requirements reflect what can be achieved with present state of the art technology.

NOTE 3: Requirement on the UE shall be reconsidered when the state of the art technology progresses.

The normative reference for this requirement is TS 25.101 [1] clause 6.6.2.2.1.

5.10B.3 Test purpose

To verify that the UE ACLR does not exceed prescribed limit shown in table 5.10B.1. This is applicable for all values of β_c , β_d , β_{hs} , β_{ec} and β_{ed} as specified in [5]. The maximum output power with HS-DPCCH and/or E-DCH is specified in table 5.2B.1.

Excess ACLR increases the interference to other channels or to other systems.

5.10B.4 Method of test

5.10B.4.1 Initial conditions

Test environment: normal, TL/VL, TL/VH, TH/VL, TH/VH; see clauses G.2.1 and G.2.2.

Frequencies to be tested: low range, mid range, high range; see clause G.2.4.

- 1) Connect the SS (node B emulator) to the UE antenna connector as shown in figure A.1.
- 2) The UL Reference Measurement Channel and the Fixed Reference Channels (FRC H-Set 1, QPSK) are specified in Annex C.11.1 and C.8.1.1.
- 3) An E-DCH call is set up according to TS 34.108 [3] 7.3.9, with the exceptions in the RADIO BEARER SETUP messages as given in Tables 5.2B.1A, 5.2B.2, 5.2B.3 and 5.2B.4. These exceptions allow the beta values to be set according to table C.11.1.3 and each UL physical channel to be at constant power during the measurement. RF parameters are set up according to table E.5A.1. Settings for the serving cell are defined in table 5.10B.1A.
- 4) Enter the UE into loopback test mode 1 looping back both the 12.2kbps RMC and HSDPA to E-DCH and start the loopback test.

See TS 34.109 [4] clauses 5.3.2.3 and 5.3.2.6 for details regarding loopback test mode for HSDPA and E-DCH.

Table 5.10B.1A: Settings for the serving cell during the measurement of Adjacent Channel Leakage Power Ratio (ACLR) with E-DCH

Parameter	Unit	Cell 1
Cell type		Serving cell
UTRA RF Channel Number		As defined in clause 5.10B.4.1
Qqualmin	dB	-24
Qrxlevmin	dBm	-115
UE_TXPWR_MAX_RACH	dBm	+21
\hat{I}_{or} (see notes 1 and 2)	dBm/3.84 MHz	-86
NOTE 1: The power level is specified in terms of \hat{I}_{or} instead of CPICH_RSCP because RSCP is a receiver measurement, whereas the SS can only set \hat{I}_{or} .		
NOTE 2: The cell fulfils TS 25.304, 5.2.3.1.2.		

5.10B.4.2 Procedure

- 1) Set UE to maximum output power according to 5.2B.4.2 steps 1 to 8.
- 2) When UE has reached the maximum power, measure the RRC filtered mean power on the wanted channel. The measurement period shall be inside the HS-DPCCH on-period for the wanted and the adjacent channels.
- 3) Measure the RRC filtered mean power of the first adjacent channels and the second adjacent channels.
- 4) Calculate the ratio of the power between the values measured in step 2) and step 3).
- 5) Repeat steps 1-4 for all the different combinations of beta values as given in table C.11.1.3.

5.10B.5 Test requirements

The measured ACLR, derived in step 4), shall be higher than the limit in table 5.10B.2.

Table 5.10B.2: UE ACLR

Power Class	UE channel	ACLR limit
3	+5 MHz or -5 MHz	32.2 dB
3	+10 MHz or -10 MHz	42.2 dB
4	+5 MHz or -5 MHz	32.2 dB
4	+10 MHz or -10 MHz	42.2 dB

NOTE: If the above Test Requirement differs from the Minimum Requirement then the Test Tolerance applied for this test is non-zero. The Test Tolerance for this test is defined in clause F.2 and the explanation of how the Minimum Requirement has been relaxed by the Test Tolerance is given in clause

5.11 Spurious Emissions

5.11.1 Definition and applicability

Spurious emissions are emissions which are caused by unwanted transmitter effects such as harmonics emission, parasitic emission, intermodulation products and frequency conversion products, but exclude out of band emissions.

The frequency boundary and the detailed transitions of the limits between the requirement for out band emissions and spectrum emissions are based on ITU-R Recommendations SM.329.

The requirements and this test apply to all types of UTRA for the FDD UE.

5.11.2 Minimum Requirements

These requirements are only applicable for frequencies, which are greater than 12.5 MHz away from the UE centre carrier frequency.

Table 5.11.1a: General spurious emissions requirements

Frequency Bandwidth	Measurement Bandwidth	Minimum requirement
$9 \text{ kHz} \leq f < 150 \text{ kHz}$	1 kHz	-36 dBm
$150 \text{ kHz} \leq f < 30 \text{ MHz}$	10 kHz	-36 dBm
$30 \text{ MHz} \leq f < 1\,000 \text{ MHz}$	100 kHz	-36 dBm
$1 \text{ GHz} \leq f < 12,75 \text{ GHz}$	1 MHz	-30 dBm

Table 5.11.1b: Additional spurious emissions requirements

Operating Band	Frequency Bandwidth	Measurement Bandwidth	Minimum requirement
I	$860 \text{ MHz} \leq f \leq 895 \text{ MHz}$	3.84 MHz	-60 dBm
	$921 \text{ MHz} \leq f < 925 \text{ MHz}$	100 kHz	-60 dBm (see note 1)
	$925 \text{ MHz} \leq f \leq 935 \text{ MHz}$	100 kHz 3.84 MHz	-67 dBm (see note 1) -60 dBm
	$935 \text{ MHz} < f \leq 960 \text{ MHz}$	100 kHz	-79 dBm (see note 1)
	$1475.9 \text{ MHz} \leq f \leq 1500.9 \text{ MHz}$	3.84 MHz	-60 dBm
	$1805 \text{ MHz} \leq f \leq 1880 \text{ MHz}$	100 kHz	-71 dBm (see note 1)
	$1844.9 \text{ MHz} \leq f \leq 1879.9 \text{ MHz}$	3.84 MHz	-60 dBm
	$1884.5 \text{ MHz} < f < 1919.6 \text{ MHz}$	300 kHz	-41 dBm
	$2110 \text{ MHz} \leq f \leq 2170 \text{ MHz}$	3.84 MHz	-60 dBm
II	$869 \text{ MHz} \leq f \leq 894 \text{ MHz}$	3.84 MHz	-60 dBm
	$1930 \text{ MHz} \leq f \leq 1990 \text{ MHz}$	3.84 MHz	-60 dBm
	$2110 \text{ MHz} \leq f \leq 2170 \text{ MHz}$	3.84 MHz	-60 dBm
III	$921 \text{ MHz} \leq f < 925 \text{ MHz}$	100 kHz	-60 dBm (see note 1)
	$925 \text{ MHz} \leq f \leq 935 \text{ MHz}$	100 kHz 3.84 MHz	-67 dBm (see note 1) -60 dBm
	$935 \text{ MHz} < f \leq 960 \text{ MHz}$	100 kHz	-79 dBm (see note 1)
	$1805 \text{ MHz} \leq f \leq 1880 \text{ MHz}$	3.84 MHz	-60 dBm
	$2110 \text{ MHz} \leq f \leq 2170 \text{ MHz}$	3.84 MHz	-60 dBm
	$2620 \text{ MHz} \leq f \leq 2690 \text{ MHz}$	3.84 MHz	-60 dBm
IV	$869 \text{ MHz} \leq f \leq 894 \text{ MHz}$	3.84 MHz	-60 dBm
	$1930 \text{ MHz} \leq f \leq 1990 \text{ MHz}$	3.84 MHz	-60 dBm
	$2110 \text{ MHz} \leq f \leq 2170 \text{ MHz}$	3.84 MHz	-60 dBm
V	$869 \text{ MHz} \leq f \leq 894 \text{ MHz}$	3.84 MHz	-60 dBm
	$1930 \text{ MHz} \leq f \leq 1990 \text{ MHz}$	3.84 MHz	-60 dBm
	$2110 \text{ MHz} \leq f \leq 2170 \text{ MHz}$	3.84 MHz	-60 dBm
VI	$860 \text{ MHz} \leq f < 875 \text{ MHz}$	1 MHz	-37 dBm
	$875 \text{ MHz} \leq f \leq 895 \text{ MHz}$	3.84 MHz	-60 dBm
	$1475.9 \text{ MHz} \leq f \leq 1500.9 \text{ MHz}$	3.84 MHz	-60 dBm
	$1844.9 \text{ MHz} \leq f \leq 1879.9 \text{ MHz}$	3.84 MHz	-60 dBm
	$1884.5 \text{ MHz} \leq f \leq 1919.6 \text{ MHz}$	300 kHz	-41 dBm
	$2110 \text{ MHz} \leq f \leq 2170 \text{ MHz}$	3.84 MHz	-60 dBm
VII	$921 \text{ MHz} \leq f < 925 \text{ MHz}$	100 kHz	-60 dBm (see note 1)
	$925 \text{ MHz} \leq f \leq 935 \text{ MHz}$	100 kHz 3.84 MHz	-67 dBm (see note 1) -60 dBm
	$935 \text{ MHz} < f \leq 960 \text{ MHz}$	100 kHz	-79 dBm (see note 1)
	$1805 \text{ MHz} \leq f \leq 1880 \text{ MHz}$	100 kHz	-71 dBm (see note 1)
	$2110 \text{ MHz} \leq f \leq 2170 \text{ MHz}$	3.84 MHz	-60 dBm
	$2620 \text{ MHz} \leq f \leq 2690 \text{ MHz}$	3.84 MHz	-60 dBm
	$2590 \text{ MHz} \leq f \leq 2620 \text{ MHz}$	3.84 MHz	-50 dBm
VIII	$925 \text{ MHz} \leq f \leq 935 \text{ MHz}$	100 kHz 3.84 MHz	-67 dBm (see note 1) -60 dBm
	$935 \text{ MHz} < f \leq 960 \text{ MHz}$	100 kHz 3.84 MHz	-79 dBm (see note 1) -60 dBm
	$1805 \text{ MHz} < f \leq 1830 \text{ MHz}$	100 kHz 3.84 MHz	-71 dBm (see notes 1 and 2) -60 dBm (see note 2)
	$1830 \text{ MHz} < f \leq 1880 \text{ MHz}$	100 kHz 3.84 MHz	-71 dBm (see note 1) -60 dBm
	$2110 \text{ MHz} \leq f \leq 2170 \text{ MHz}$	3.84 MHz	-60 dBm
	$2620 \text{ MHz} \leq f \leq 2640 \text{ MHz}$	3.84 MHz	-60 dBm
	$2640 \text{ MHz} < f \leq 2690 \text{ MHz}$	3.84 MHz	-60 dBm (see note 2)
IX	$860 \text{ MHz} \leq f \leq 895 \text{ MHz}$	3.84 MHz	-60 dBm
	$1475.9 \text{ MHz} \leq f \leq 1500.9 \text{ MHz}$	3.84 MHz	-60 dBm
	$1844.9 \text{ MHz} \leq f \leq 1879.9 \text{ MHz}$	3.84 MHz	-60 dBm
	$1884.5 \text{ MHz} \leq f \leq 1919.6 \text{ MHz}$	300 kHz	-41 dBm
	$2110 \text{ MHz} \leq f \leq 2170 \text{ MHz}$	3.84 MHz	-60 dBm
X	$869 \text{ MHz} \leq f \leq 894 \text{ MHz}$	3.84 MHz	-60 dBm

	$1930 \text{ MHz} \leq f \leq 1990 \text{ MHz}$	3.84 MHz	-60 dBm
	$2110 \text{ MHz} \leq f \leq 2170 \text{ MHz}$	3.84 MHz	-60 dBm
XI	$860 \text{ MHz} \leq f \leq 895 \text{ MHz}$	3.84 MHz	-60 dBm
	$1475.9 \text{ MHz} \leq f \leq 1500.9 \text{ MHz}$	3.84 MHz	-60 dBm
	$1844.9 \text{ MHz} \leq f \leq 1879.9 \text{ MHz}$	3.84 MHz	-60 dBm
	$1884.5 \text{ MHz} \leq f \leq 1919.6 \text{ MHz}$	300 kHz	-41 dBm
	$2110 \text{ MHz} \leq f \leq 2170 \text{ MHz}$	3.84 MHz	-60 dBm
NOTE 1: The measurements are made on frequencies which are integer multiples of 200 kHz. As exceptions, up to five measurements with a level up to the applicable requirements defined in table 5.11.1a are permitted for each UARFCN used in the measurement			
NOTE 2: The measurements are made on frequencies which are integer multiples of 200 kHz. As exceptions, measurements with a level up to the applicable requirements defined in Table 5.11.1a are permitted for each UARFCN used in the measurement due to 2 nd or 3 rd harmonic spurious emissions			

NOTE: The applicability of each line in Table 5.11.1b for UEs of different releases is defined in TS 25.101 [1] and TS 25.307 [26].

As exceptions, up to five measurements with a level up to the applicable requirements defined in table 5.11.1a are permitted in each of the bands, 925 MHz to 960 MHz and 1805 MHz to 1880 MHz for each UARFCN used in the measurement. The reference is 3GPP TS 45.005 [29].

The normative reference for this requirement is TS 25.101 [1] clause 6.6.3.1.

5.11.3 Test purpose

To verify that the UE spurious emissions do not exceed described value shown in table 5.11.1a and table 5.11.1b.

Excess spurious emissions increase the interference to other systems.

5.11.4 Method of test

5.11.4.1 Initial conditions

Test environment: normal; see clauses G.2.1 and G.2.2.

Frequencies to be tested: low range, mid range, high range; see clause G.2.4.

- 1) Connect the SS to the UE antenna connector as shown in figure A.8.
- 2) A call is set up according to the Generic call setup procedure in TS34.108 [3] sub clause 7.3.2.
- 3) Enter the UE into loopback test mode and start the loopback test.

See TS 34.108 [3] and TS 34.109 [4] for details regarding generic call setup procedure and loopback test.

5.11.4.2 Procedure

- 1) Set and send continuously Up power control commands to the UE until the UE output power shall be maximum level.
- 2) Sweep the spectrum analyzer (or equivalent equipment) over a frequency range and measure the average power of spurious emission.

5.11.5 Test requirements

The measured average power of spurious emission, derived in step 2), shall not exceed the described value in tables 5.11.2a and 5.11.2b.

These requirements are only applicable for frequencies, which are greater than 12,5 MHz away from the UE centre carrier frequency.

Table 5.11.2a: General spurious emissions test requirements

Frequency Bandwidth	Measurement Bandwidth	Minimum requirement
$9 \text{ kHz} \leq f < 150 \text{ kHz}$	1 kHz	-36 dBm
$150 \text{ kHz} \leq f < 30 \text{ MHz}$	10 kHz	-36 dBm
$30 \text{ MHz} \leq f < 1\,000 \text{ MHz}$	100 kHz	-36 dBm
$1 \text{ GHz} \leq f < 12,75 \text{ GHz}$	1 MHz	-30 dBm

Table 5.11.2b: Additional spurious emissions test requirements

Operating Band	Frequency Bandwidth	Measurement Bandwidth	Minimum requirement
I	$860 \text{ MHz} \leq f \leq 895 \text{ MHz}$	3.84 MHz	-60 dBm
	$921 \text{ MHz} \leq f < 925 \text{ MHz}$	100 kHz	-60 dBm (see note 1)
	$925 \text{ MHz} \leq f \leq 935 \text{ MHz}$	100 kHz 3.84 MHz	-67 dBm (see note 1) -60 dBm
	$935 \text{ MHz} < f \leq 960 \text{ MHz}$	100 kHz	-79 dBm (see note 1)
	$1475.9 \text{ MHz} \leq f \leq 1500.9 \text{ MHz}$	3.84 MHz	-60 dBm
	$1805 \text{ MHz} \leq f \leq 1880 \text{ MHz}$	100 kHz	-71 dBm (see note 1)
	$1844.9 \text{ MHz} \leq f \leq 1879.9 \text{ MHz}$	3.84 MHz	-60 dBm
	$1884.5 \text{ MHz} < f < 1919.6 \text{ MHz}$	300 kHz	-41 dBm
	$2110 \text{ MHz} \leq f \leq 2170 \text{ MHz}$	3.84 MHz	-60 dBm
II	$2620 \text{ MHz} \leq f \leq 2690 \text{ MHz}$	3.84 MHz	-60 dBm
	$869 \text{ MHz} \leq f \leq 894 \text{ MHz}$	3.84 MHz	-60 dBm
	$1930 \text{ MHz} \leq f \leq 1990 \text{ MHz}$	3.84 MHz	-60 dBm
	$2110 \text{ MHz} \leq f \leq 2155 \text{ MHz}$	3.84 MHz	-60 dBm (see note 3)
III	$2110 \text{ MHz} \leq f \leq 2170 \text{ MHz}$	3.84 MHz	-60 dBm (see note 4)
	$921 \text{ MHz} \leq f < 925 \text{ MHz}$	100 kHz	-60 dBm (see note 1)
	$925 \text{ MHz} \leq f \leq 935 \text{ MHz}$	100 kHz 3.84 MHz	-67 dBm (see note 1) -60 dBm
	$935 \text{ MHz} < f \leq 960 \text{ MHz}$	100 kHz	-79 dBm (see note 1)
	$1805 \text{ MHz} \leq f \leq 1880 \text{ MHz}$	3.84 MHz	-60 dBm
	$2110 \text{ MHz} \leq f \leq 2170 \text{ MHz}$	3.84 MHz	-60 dBm
IV	$2620 \text{ MHz} \leq f \leq 2690 \text{ MHz}$	3.84 MHz	-60 dBm
	$869 \text{ MHz} \leq f \leq 894 \text{ MHz}$	3.84 MHz	-60 dBm
	$1930 \text{ MHz} \leq f \leq 1990 \text{ MHz}$	3.84 MHz	-60 dBm
	$2110 \text{ MHz} \leq f \leq 2155 \text{ MHz}$	3.84 MHz	-60 dBm (see note 3)
V	$2110 \text{ MHz} \leq f \leq 2170 \text{ MHz}$	3.84 MHz	-60 dBm (see note 4)
	$869 \text{ MHz} \leq f \leq 894 \text{ MHz}$	3.84 MHz	-60 dBm
	$1930 \text{ MHz} \leq f \leq 1990 \text{ MHz}$	3.84 MHz	-60 dBm
	$2110 \text{ MHz} \leq f \leq 2155 \text{ MHz}$	3.84 MHz	-60 dBm (see note 3)
VI	$2110 \text{ MHz} \leq f \leq 2170 \text{ MHz}$	3.84 MHz	-60 dBm (see note 4)
	$860 \text{ MHz} \leq f < 875 \text{ MHz}$	1 MHz	-37 dBm
	$875 \text{ MHz} \leq f \leq 895 \text{ MHz}$	3.84 MHz	-60 dBm
	$1475.9 \text{ MHz} \leq f \leq 1500.9 \text{ MHz}$	3.84 MHz	-60 dBm
	$1844.9 \text{ MHz} \leq f \leq 1879.9 \text{ MHz}$	3.84 MHz	-60 dBm
	$1884.5 \text{ MHz} \leq f \leq 1919.6 \text{ MHz}$	300 kHz	-41 dBm
VII	$2110 \text{ MHz} \leq f \leq 2170 \text{ MHz}$	3.84 MHz	-60 dBm
	$921 \text{ MHz} \leq f < 925 \text{ MHz}$	100 kHz	-60 dBm (see note 1)
	$925 \text{ MHz} \leq f \leq 935 \text{ MHz}$	100 kHz 3.84 MHz	-67 dBm (see note 1) -60 dBm
	$935 \text{ MHz} < f \leq 960 \text{ MHz}$	100 kHz	-79 dBm (see note 1)
	$1805 \text{ MHz} \leq f \leq 1880 \text{ MHz}$	100 kHz	-71 dBm (see note 1)
	$2110 \text{ MHz} \leq f \leq 2170 \text{ MHz}$	3.84 MHz	-60 dBm
	$2620 \text{ MHz} \leq f \leq 2690 \text{ MHz}$	3.84 MHz	-60 dBm
VIII	$2590 \text{ MHz} \leq f \leq 2620 \text{ MHz}$	3.84 MHz	-50 dBm
	$925 \text{ MHz} \leq f \leq 935 \text{ MHz}$	100 kHz 3.84 MHz	-67 dBm (see note 1) -60 dBm
	$935 \text{ MHz} < f \leq 960 \text{ MHz}$	100 kHz 3.84 MHz	-79 dBm (see note 1) -60 dBm
	$1805 \text{ MHz} < f \leq 1830 \text{ MHz}$	100 kHz 3.84 MHz	-71 dBm (see notes 1 and 2) -60 dBm (see note 2)
	$1830 \text{ MHz} < f \leq 1880 \text{ MHz}$	100 kHz 3.84 MHz	-71 dBm (see note 1) -60 dBm
	$2110 \text{ MHz} \leq f \leq 2170 \text{ MHz}$	3.84 MHz	-60 dBm
	$2620 \text{ MHz} \leq f \leq 2640 \text{ MHz}$	3.84 MHz	-60 dBm

	2640 MHz < f ≤ 2690 MHz	3.84 MHz	-60 dBm (see note 2)
IX	860 MHz ≤ f ≤ 895 MHz	3.84 MHz	-60dBm
	1475.9 MHz ≤ f ≤ 1500.9 MHz	3.84 MHz	-60 dBm
	1844.9 MHz ≤ f ≤ 1879.9 MHz	3.84 MHz	-60dBm
	1884.5 MHz ≤ f ≤ 1919.6 MHz	300 kHz	-41 dBm
	2110 MHz ≤ f ≤ 2170 MHz	3.84 MHz	-60 dBm
X	860 MHz ≤ f ≤ 895 MHz	3.84 MHz	-60 dBm
	1930 MHz ≤ f ≤ 1990 MHz	3.84 MHz	-60 dBm
	2110 MHz ≤ f ≤ 2170 MHz	3.84 MHz	-60 dBm
XI	860 MHz ≤ f ≤ 895 MHz	3.84 MHz	-60 dBm
	1475.9 MHz ≤ f ≤ 1500.9 MHz	3.84 MHz	-60 dBm
	1844.9 MHz ≤ f ≤ 1879.9 MHz	3.84 MHz	-60 dBm
	1884.5 MHz ≤ f ≤ 1919.6 MHz	300 kHz	-41 dBm
	2110 MHz ≤ f ≤ 2170 MHz	3.84 MHz	-60 dBm
NOTE 1: The measurements are made on frequencies which are integer multiples of 200 kHz. As exceptions, up to five measurements with a level up to the applicable requirements defined in table 5.11.2a are permitted for each UARFCN used in the measurement			
NOTE 2: The measurements are made on frequencies which are integer multiples of 200 kHz. As exceptions, measurements with a level up to the applicable requirements defined in Table 5.11.2a are permitted for each UARFCN used in the measurement due to 2 nd or 3 rd harmonic spurious emissions.			
NOTE 3: For UEs that conform to Release 6 and support Band II, IV or V shall support the defined frequency bandwidth.			
NOTE 4: For UEs that conform to Release 7 and later releases and support Band II, IV or V shall support the defined frequency bandwidth.			
NOTE 5: The applicability of each line in Table 5.11.2b for UEs of different releases is defined in TS 25.101 [1] and TS 25.307 [26].			

NOTE: The applicability of each line in Table 5.11.2b for UEs of different releases is defined in TS 25.101 [1] and TS 25.307 [26].

As exceptions, up to five measurements with a level up to the applicable requirements defined in table 5.11.2a are permitted in each of the bands, 925 MHz to 960 MHz and 1805 MHz to 1880 MHz for each UARFCN used in the measurement. The reference is 3GPP TS 45.005 [29].

NOTE: If the above Test Requirement differs from the Minimum Requirement then the Test Tolerance applied for this test is non-zero. The Test Tolerance for this test is defined in clause F.2 and the explanation of how the Minimum Requirement has been relaxed by the Test Tolerance is given in clause F.4.

5.12 Transmit Intermodulation

5.12.1 Definition and applicability

The transmit intermodulation performance is a measure of the capability of the transmitter to inhibit the generation of signals in its non linear elements caused by presence of the wanted signal and an interfering signal reaching the transmitter via the antenna.

UE(s) transmitting in close vicinity of each other can produce intermodulation products, which can fall into the UE, or Node B receive band as an unwanted interfering signal. The UE transmit intermodulation attenuation is defined by the ratio of the RRC filtered mean power of the wanted signal to the RRC filtered mean power of the intermodulation product when an interfering CW signal is added at a level below the wanted signal.

The requirements and this test apply to all types of UTRA for the FDD UE.

5.12.2 Minimum Requirements

The UE transmit intermodulation shall not exceed the described value in table 5.12.1.

Table 5.12.1: Transmit Intermodulation

CW Signal Frequency Offset from Transmitting Carrier	5MHz	10MHz
Interference CW Signal Level	-40 dBc	
Intermodulation Product	-31 dBc	-41 dBc

The normative reference for this requirement is TS 25.101 [1] clause 6.7.1.

5.12.3 Test purpose

To verify that the UE transmit intermodulation does not exceed the described value in table 5.12.1.

An excess transmit intermodulation increases transmission errors in the up link own channel when other transmitter exists nearby.

5.12.4 Method of test

5.12.4.1 Initial conditions

Test environment: normal; see clauses G.2.1 and G.2.2.

Frequencies to be tested: mid range; see clause G.2.4.

- 1) Connect the SS to the UE antenna connector as shown in figure A.2.
- 2) A call is set up according to the Generic call setup procedure in TS34.108 [3] sub clause 7.3.2.
- 3) Enter the UE into loopback test mode and start the loopback test.

See TS 34.108 [3] and TS 34.109 [4] for details regarding generic call setup procedure and loopback test.

5.12.4.2 Procedure

- 1) Set and send continuously Up power control commands to the UE until the UE output power shall be maximum level.
- 2) Set the frequency of the CW generator to the offset 1 or offset 2 as shown in table 5.12.2.
- 3) Measure the RRC filtered mean power of the UE.
- 4) Search the intermodulation product signal, then measure the RRC filtered mean power of transmitting intermodulation, and calculate the ratio with the power measured in step 3).
- 5) Repeat the measurement with another tone offset.

5.12.5 Test requirements

The ratio derived in step 4), shall not exceed the described value in table 5.12.2.

Table 5.12.2: Transmit Intermodulation

CW Signal Frequency Offset from Transmitting Carrier	5MHz	10MHz
Interference CW Signal Level	-40 dBc	
Intermodulation Product	-31 dBc	-41 dBc

NOTE: If the above Test Requirement differs from the Minimum Requirement then the Test Tolerance applied for this test is non-zero. The Test Tolerance for this test is defined in clause F.2 and the explanation of how the Minimum Requirement has been relaxed by the Test Tolerance is given in clause F.4.

5.13 Transmit Modulation

Transmit modulation defines the modulation quality for expected in-channel RF transmissions from the UE. The requirements apply to all transmissions including the PRACH/PCPCH pre-amble and message parts and all other expected transmissions for release 99 and release 4 only. For release 5 and later the requirements apply to all transmissions including the PRACH pre-amble and message parts and all other expected transmissions. In cases where the mean power of the RF signal is allowed to change versus time e.g. PRACH, DPCH in compressed mode, change of TFC, inner loop power control and for HSDPA transmissions with non-constant HS-DPCCH code power, the EVM and Peak Code Domain Error requirements do not apply during the 25 μ s period before and after the nominal time when the mean power is expected to change.

5.13.1 Error Vector Magnitude (EVM)

5.13.1.1 Definition and applicability

The Error Vector Magnitude is a measure of the difference between the reference waveform and the measured waveform. This difference is called the error vector. Both waveforms pass through a matched Root Raised Cosine filter with bandwidth 3,84 MHz and roll-off $\alpha=0,22$. Both waveforms are then further modified by selecting the frequency, absolute phase, absolute amplitude and chip clock timing so as to minimise the error vector. The EVM result is defined as the square root of the ratio of the mean error vector power to the mean reference power expressed as a %.

For Release 99 and Release 4 the measurement interval is one timeslot.

For Release 5 and later releases where tests may include power changes, the measurement interval is further clarified as being one timeslot except when the mean power between slots is expected to change whereupon the measurement interval is reduced by 25 μ s at each end of the slot. The requirements and this test apply to all types of UTRA for the FDD UE.

5.13.1.2 Minimum Requirements

The EVM shall not exceed 17,5 % for the parameters specified in table 5.13.1.

Table 5.13.1: Parameters for EVM

Parameter	Level / Status	Unit
Output power	≥ -20	dBm
Operating conditions	Normal conditions	
Power control step size	1	dB

The normative reference for this requirement is TS 25.101 [1] clause 6.8.2.1.

5.13.1.3 Test purpose

To verify that the EVM does not exceed 17,5 % for the specified parameters in table 5.13.1.

An excess EVM increases transmission errors in the up link own channel.

5.13.1.4 Method of test

5.13.1.4.1 Initial conditions

Test environment: normal; see clauses G.2.1 and G.2.2.

Frequencies to be tested: low range, mid range, high range; see clause G.2.4.

- 1) Connect the SS to the UE antenna connector as shown in figure A.1.
- 2) A call is set up according to the Generic call setup procedure in TS34.108 [3] sub clause 7.3.2.
- 3) Enter the UE into loopback test mode and start the loopback test.

See TS 34.108 [3] and TS 34.109 [4] for details regarding generic call setup procedure and loopback test.

5.13.1.4.2 Procedure

- 1) Set and send continuously Up power control commands to the UE until the UE output power shall be maximum level.
- 2) Measure the EVM using Global In-Channel Tx-Test (annex B).
- 3) Set the power level of UE to -18dBm or send Down power control commands (1dB step size should be used.) to the UE until UE output power shall be -18dBm with $\pm 2\text{dB}$ tolerance.
- 4) Repeat step 2).

5.13.1.5 Test requirements

The measured EVM, derived in step 2) and 4), shall not exceed 17,5 % for parameters specified in table 5.13.1 Parameters for EVM.

NOTE: If the above Test Requirement differs from the Minimum Requirement then the Test Tolerance applied for this test is non-zero. The Test Tolerance for this test is defined in clause F.2 and the explanation of how the Minimum Requirement has been relaxed by the Test Tolerance is given in clause F.4.

5.13.1A Error Vector Magnitude (EVM) with HS-DPCCH

5.13.1A.1 Definition and applicability

The Error Vector Magnitude is a measure of the difference between the reference waveform and the measured waveform. This difference is called the error vector. Both waveforms pass through a matched Root Raised Cosine filter with bandwidth 3,84 MHz and roll-off $\alpha=0,22$. Both waveforms are then further modified by selecting the frequency, absolute phase, absolute amplitude and chip clock timing so as to minimise the error vector. The EVM result is defined as the square root of the ratio of the mean error vector power to the mean reference power expressed as a %.

The measurement interval is one timeslot except when the mean power between slots is expected to change whereupon the measurement interval is reduced by 25 μs at each end of the slot.

For signals containing more than one spreading code where the slot alignment of the codes is not the same and the code power is varying, the period over which the nominal mean power remains constant can be less than one timeslot. For such time-varying signals it is not possible to define EVM across one timeslot since this interval contains an expected change in mean power, and the exact timing and trajectory of the power change is not defined. For these signals, the EVM minimum requirements apply only for intervals of at least one half timeslot (less any 25 μs transient periods) during which the nominal code power of each individual code is constant.

Note: The reason for setting a lower limit for the EVM measurement interval is that for any given impaired signal, the EVM would be expected to improve for measurement intervals less than one timeslot while the frequency error would be expected to degrade.

The requirements and this test apply for Release 5 only to all types of UTRA for the FDD UE that support HSDPA.

5.13.1A.2 Minimum Requirements

The EVM shall not exceed 17.5 % for the parameters specified in table 5.13.1A.1. This is applicable for all values of β_c , β_d and β_{hs} as specified in [5].

Table 5.13.1A.1: Parameters for EVM

Parameter		Level / Status	Unit
Output power		≥ -20	dBm
Operating conditions		Normal conditions	
Power control step size		1	dB
Measurement period ¹	PRACH	3904	Chips
	Any DPCH	From 1280 to 2560 ²	
Note 1: Less any 25 μs transient periods			
Note 2: The longest period over which the nominal power remains constant			

The normative reference for this requirement is TS 25.101 [1] clause 6.8.2.1.

5.13.1A.3 Test purpose

To verify that the EVM does not exceed 17.5 % for the specified parameters in table 5.13.1A.1 using the values of β_c , β_d and β_{hs} specified in table C.10.1.4 for subtest 3.

5.13.1A.4 Method of test

5.13.1A.4.1 Initial conditions

Test environment: normal; see clauses G.2.1 and G.2.2.

Frequencies to be tested: low range, mid range, high range; see clause G.2.4.

- 1) Connect the SS (node B emulator) to the UE antenna connector as shown in figure A.1.
- 2) The UL Reference Measurement Channel and the Fixed Reference Channels (FRC H-Set 1, QPSK version) are specified in Annex C.10.1 and C.8.1.1.
- 3) An HSDPA call is set up according to TS 34.108 [3] clause 7.3.6. RF parameters are set up according to table E.5.1 and table E.5.10. Settings for the serving cell are defined in table 5.13.1A.2. Set the Default DPCH Offset Value according to the required HS-DPCCH slot offset as specified in TS 25.331 [8] clause 8.6.6.14 and TS 25.211 [19].
- 4) Enter the UE into loopback test mode in the presence of HSDPA and start the loopback test.

See TS 34.108 [3] and TS 34.109 [4] for details regarding loopback test mode for HSDPA.

Table 5.13.1A.2: Settings for the serving cell during the measurement of Error Vector Magnitude (EVM) with HS-DPCCH

Parameter	Unit	Cell 1
Cell type		Serving cell
UTRA RF Channel Number		As defined in clause 5.13.1A.4.1
Qqualmin	dB	-24
Qrxlevmin	dBm	-115
UE_TXPWR_MAX_RACH	dBm	+21
\hat{I}_{or} (see notes 1 and 2)	dBm/3.84 MHz	-86
NOTE 1: The power level is specified in terms of \hat{I}_{or} instead of CPICH_RSCP because RSCP is a receiver measurement, whereas the SS can only set \hat{I}_{or} .		
NOTE 2: The cell fulfils TS 25.304, 5.2.3.1.2.		

5.13.1A.4.2 Procedure

- 1) Send the TRANSPORT CHANNEL RECONFIGURATION message defined in Annex I to set the beta values according to table C.10.1.4 subtest 3 and the DPCH frame offset according the HS-DPCCH half slot offset required for measurements. This will create a signal with a repeat pattern of 12ms as shown in Figure 5.13.1A.1. The Uplink DPCH Power Control Info shall specify the Power Control Algorithm as algorithm 2 for interpreting TPC commands.
- 2) Generate suitable TPC commands from the SS such that the half slot period with the highest output power for the defined 12ms sequence as measured at the UE antenna connector is the maximum output as defined in table 5.2A.1. Maintain this power level by sending alternating "0" and "1" TPC commands in the downlink so as to satisfy the condition of obtaining TPC_cmd = 0.
- 3) Start transmitting HSDPA Data.
- 4) With reference to Figure 5.13.1A.1 measure the EVM using Global In-Channel Tx-Test (annex B) during the last half slot period of the ACK/NACK in subframe n+3 when the UE is at its maximum power in the 12ms cycle (measurement point 3) and in the following half slot period when the CQI is off (measurement point 4) and the UE is at its minimum power in the cycle. Measure the EVM in the last half slot before subframe n when the UE is at its minimum power (measurement point 1) and immediately following in the first half slot of subframe n

when the ACK/NACK is transmitting and the UE is at its maximum power in the 12ms cycle (measurement point 2). All measurements shall exclude the 25 us transient periods at the beginning and end of each measurement period.

- 5) Generate suitable TPC commands from the SS such that the half slot period with the lowest output power for the defined 12ms sequence as measured at the UE antenna connector is -18dBm with ±2dB tolerance. Maintain this power level by sending alternating "0" and "1" TPC commands in the downlink so as to satisfy the condition of obtaining TPC_cmd = 0.
- 6) Repeat step 4).

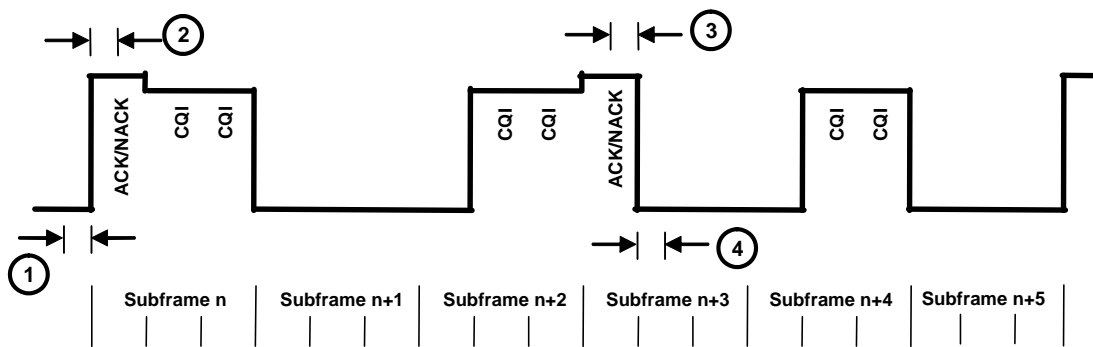

Figure 5.13.1A.1: HS-DPCCH on/off pattern showing measurement positions

All messages indicated above shall use the same content as described in the default message content in clause 9 of TS 34.108 [3], except the TRANSPORT CHANNEL RECONFIGURATION message which is defined in Annex I. The test specific exception for the TRANSPORT CHANNEL RECONFIGURATION message is as follows:

Information Element	Value/remark
- Ack-Nack repetition factor	1
- CQI repetition factor	1

5.13.1A.5 Test requirements

The measured EVM, derived in steps 4) and 6), shall not exceed 17.5 % for parameters specified in table 5.13.1A.1 parameters for EVM.

NOTE: If the above Test Requirement differs from the Minimum Requirement then the Test Tolerance applied for this test is non-zero. The Test Tolerance for this test is defined in clause F.2 and the explanation of how the Minimum Requirement has been relaxed by the Test Tolerance is given in clause F.4.

5.13.1AA Error Vector Magnitude (EVM) and phase discontinuity with HS-DPCCH

5.13.1AA.1 Definition and applicability

The Error Vector Magnitude is a measure of the difference between the reference waveform and the measured waveform. This difference is called the error vector. Both waveforms pass through a matched Root Raised Cosine filter with bandwidth 3,84 MHz and roll-off $\alpha=0,22$. Both waveforms are then further modified by selecting the frequency, absolute phase, absolute amplitude and chip clock timing so as to minimise the error vector. The EVM result is defined as the square root of the ratio of the mean error vector power to the mean reference power expressed as a %.

The measurement interval is one timeslot except when the mean power between slots is expected to change whereupon the measurement interval is reduced by 25 µs at each end of the slot.

For signals containing more than one spreading code where the slot alignment of the codes is not the same and the code power is varying, the period over which the nominal mean power remains constant can be less than one timeslot. For such time-varying signals it is not possible to define EVM across one timeslot since this interval contains an expected

change in mean power, and the exact timing and trajectory of the power change is not defined. For these signals, the EVM minimum requirements apply only for intervals of at least one half timeslot (less any 25µs transient periods) during which the nominal code power of each individual code is constant.

Note: The reason for setting a lower limit for the EVM measurement interval is that for any given impaired signal, the EVM would be expected to improve for measurement intervals less than one timeslot while the frequency error would be expected to degrade.

Phase discontinuity for HS-DPCCH is the change in phase due to the transmission of the HS-DPCCH. In the case where the HS-DPCCH timeslot is offset from the DPCCH timeslot, the period of evaluation of the phase discontinuity shall be the DPCCH timeslot that contains the HS-DPCCH slot boundary. The phase discontinuity for HS-DPCCH result is defined as the difference between the absolute phase used to calculate the EVM for that part of the DPCCH timeslot prior to the HS-DPCCH slot boundary, and the absolute phase used to calculate the EVM for remaining part of the DPCCH timeslot following the HS-DPCCH slot boundary. In all cases the subslot EVM is measured excluding the transient periods of 25 µs.

Since subslot EVM is only defined for intervals of at least one half timeslot, the phase discontinuity for HS-DPCCH is only defined for non-aligned timeslots when the offset is 0.5 slots.

The requirements and this test apply for Release 6 and later releases to all types of UTRA for the FDD UE that support HSDPA.

5.13.1AA.2 Minimum Requirements

The EVM shall not exceed 17.5 % for the parameters specified in table 5.13.1AA. This is applicable for all values of β_c , β_d and β_{hs} as specified in [5].

Table 5.13.1AA.1: Parameters for EVM

Parameter		Level / Status	Unit
Output power		≥ -20	dBm
Operating conditions		Normal conditions	
Power control step size		1	dB
Measurement period ¹	PRACH	3904	Chips
	Any DPCH	From 1280 to 2560 ²	
Note 1: Less any 25µs transient periods			
Note 2: The longest period over which the nominal power remains constant			

The phase discontinuity for HS-DPCCH shall not exceed the value specified in table 5.13.1AA.2 90% of the time. When calculating the phase discontinuity, the requirements for frequency error and EVM in sub clauses 6.3 and 6.8.2, of TS 25.101 [1] respectively shall be met.

Table 5.13.1AA.2: Phase discontinuity minimum requirement for HS-DPCCH at HS-DPCCH slot boundary

Phase discontinuity for HS-DPCCH $\Delta\theta$ in degrees	$\Delta\theta \leq 30$
--	------------------------

The normative reference for these requirements is TS 25.101 [1] clause 6.8.2.1 and 6.8.5.1.

5.13.1AA.3 Test purpose

To verify that the EVM does not exceed 17.5 % for the specified parameters in table 5.13.1AA using the values of β_c , β_d and β_{hs} specified in table C.10.1.4 for subtest 3.

To verify that HSDPA phase discontinuity does not exceed the values in table 5.13.1AA.2.

Note: The statistical aspect (90% pass rate) of this minimum requirement is not currently tested.

5.13.1AA.4 Method of test

5.13.1AA.4.1 Initial conditions

Test environment: normal; see clauses G.2.1 and G.2.2.

Frequencies to be tested: low range, mid range, high range; see clause G.2.4.

- 1) Connect the SS (node B emulator) to the UE antenna connector as shown in figure A.1.
- 2) The UL Reference Measurement Channel and the Fixed Reference Channels (FRC H-Set 1, QPSK version) are specified in Annex C.10.1 and C.8.1.1.
- 3) An HSDPA call is set up according to TS 34.108 [3] clause 7.3.6. RF parameters are set up according to table E.5.1 and table E.5.10. Settings for the serving cell are defined in table 5.13.1AA.3. Set the Default DPCH Offset Value according to the required HS-DPCCH slot offset as specified in TS 25.331 [8] clause 8.6.6.14 and TS 25.211 [19].
- 4) Enter the UE into loopback test mode in the presence of HSDPA and start the loopback test.

See TS 34.108 [3] and TS 34.109 [4] for details regarding loopback test mode for HSDPA.

Table 5.13.1AA.3: Settings for the serving cell during the measurement of Error Vector Magnitude (EVM) with HS-DPCCH

Parameter	Unit	Cell 1
Cell type		Serving cell
UTRA RF Channel Number		As defined in clause 5.13.1AA.4.1
Qqualmin	dB	-24
Qrxlevmin	dBm	-115
UE_TXPWR_MAX_RACH	dBm	+21
\bar{I}_{or} (see notes 1 and 2)	dBm/3.84 MHz	-86
NOTE 1: The power level is specified in terms of \bar{I}_{or} instead of CPICH_RSCP because RSCP is a receiver measurement, whereas the SS can only set \bar{I}_{or} .		
NOTE 2: The cell fulfils TS 25.304, 5.2.3.1.2.		

5.13.1AA.4.2 Procedure

- 1) Send the TRANSPORT CHANNEL RECONFIGURATION message defined in Annex I to set the beta values according to table C.10.1.4 subtest 3 and the DPCH frame offset according the HS-DPCCH half slot offset required for measurements. This will create a signal with a repeat pattern of 12ms as shown in Figure 5.13.1AA.1. The Uplink DPCH Power Control Info shall specify the Power Control Algorithm as algorithm 2 for interpreting TPC commands.
- 2) Generate suitable TPC commands from the SS such that the half slot period with the highest output power for the defined 12ms sequence as measured at the UE antenna connector is the maximum output as defined in table 5.2A.1. Maintain this power level by sending alternating "0" and "1" TPC commands in the downlink so as to satisfy the condition of obtaining $TPC_cmd = 0$.
- 3) Start transmitting HSDPA Data.
- 4) With reference to Figure 5.13.1AA.1 measure the EVM using Global In-Channel Tx-Test (annex B) during the last half slot period of the ACK/NACK in subframe n+3 when the UE is at its maximum power in the 12ms cycle (measurement point 3) and in the following half slot period when the CQI is off and the UE is at its minimum power in the cycle (measurement point 4). Compute from these two EVM results the phase discontinuity between the two half slot periods. Measure the EVM in the last half slot before subframe n when the UE is at its minimum power (measurement point 1) and immediately following in the first half slot of subframe n when the ACK/NACK is transmitting and the UE is at its maximum power in the 12ms cycle (measurement point 1). Compute from these two EVM results the phase discontinuity between the two half slot periods. All measurements shall exclude the 25 us transient periods at the beginning and end of each measurement period.
- 5) Generate suitable TPC commands from the SS such that the half slot period with the lowest output power for the defined 12ms sequence as measured at the UE antenna connector is -18dBm with ± 2 dB tolerance. Maintain this

power level by sending alternating "0" and "1" TPC commands in the downlink so as to satisfy the condition of obtaining TPC_cmd = 0.

6) Repeat step 4).

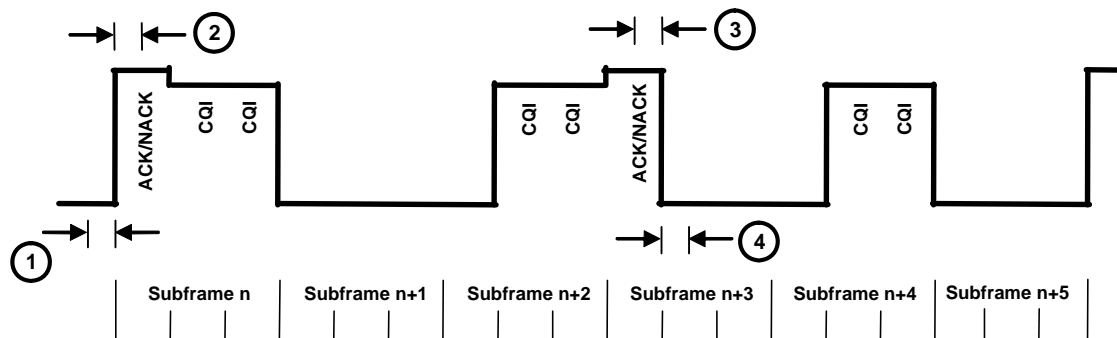

Figure 5.13.1AA.1: HS-DPCCH on/off pattern showing measurement positions

All messages indicated above shall use the same content as described in the default message content in clause 9 of TS 34.108 [3], except the TRANSPORT CHANNEL RECONFIGURATION message which is defined in Annex I. The test specific exception for the TRANSPORT CHANNEL RECONFIGURATION message is as follows:

Information Element	Value/remark
- Ack-Nack repetition factor	1
- CQI repetition factor	1

5.13.1AA.5 Test requirements

Table 5.13.1AA.4: Phase discontinuity test requirement for HS-DPCCH at HS-DPCCH slot boundary

Phase discontinuity for HS-DPCCH $\Delta\theta$ in degrees	$\Delta\theta \leq 36$
--	------------------------

The measured EVM, derived in steps 4) and 6), shall not exceed 17.5 % for parameters specified in table 5.13.1AA.1 parameters for EVM.

The measured phase discontinuity, derived in steps 4) and 6), shall not exceed the value specified in table 5.13.1AA.4.

NOTE: If the above Test Requirement differs from the Minimum Requirement then the Test Tolerance applied for this test is non-zero. The Test Tolerance for this test is defined in clause F.2 and the explanation of how the Minimum Requirement has been relaxed by the Test Tolerance is given in clause F.4.

5.13.2 Peak code domain error

5.13.2.1 Definition and applicability

The Peak Code Domain Error is computed by projecting power of the error vector (as defined in clause 5.13.1.1) onto the code domain at a specific spreading factor. The Code Domain Error for every code in the domain is defined as the ratio of the mean power of the projection onto that code, to the mean power of the composite reference waveform expressed in dB. The Peak Code Domain Error is defined as the maximum value for the Code Domain Error for all codes.

For Release 99 and Release 4 the measurement interval is one timeslot.

For Release 5 and later releases where tests may include power changes, the measurement interval is further clarified as being one timeslot except when the mean power between slots is expected to change whereupon the measurement interval is reduced by 25 μ s at each end of the slot.

The requirements and this test apply only to the UE in which the multi-code DPDCH transmission is provided and therefore does not apply for the PRACH and PCPCH preamble and message parts for R99 and Release 4 only or the PRACH preamble and message parts for Release 5 and later.

5.13.2.2 Minimum Requirements

The peak code domain error shall not exceed -15 dB at spreading factor 4 for the parameters specified in table 5.13.3. The requirements are defined using the UL reference measurement channel (768 kbps) specified in clause C.2.5.

Table 5.13.3: Parameters for Peak code domain error

Parameter	Level / Status	Unit
Output power	≥ -20	dBm
Operating conditions	Normal conditions	
Power control step size	1	dB

The normative reference for this requirement is TS 25.101 [1] clause 6.8.3.1.

5.13.2.3 Test purpose

To verify that the UE peak code domain error does not exceed -15 dB for the specified parameters in table 5.13.3.

An excess peak code domain error increases transmission errors in the up link own channel.

5.13.2.4 Method of test

5.13.2.4.1 Initial conditions

Test environment: normal; see clauses G.2.1 and G.2.2.

Frequencies to be tested: low range, mid range, high range; see clause G.2.4.

- 1) Connect the SS to the UE antenna connector as shown in figure A.1.
- 2) A call is set up according to the Generic call setup procedure in TS34.108 [3] sub clause 7.3.2, and RF parameters are set up according to table 5.13.4.
- 3) Enter the UE into loopback test mode and start the loopback test.

See TS 34.108 [3] and TS 34.109 [4] for details regarding generic call setup procedure and loopback test.

Table 5.13.4: Test parameters for Peak code domain error

Parameter	Level / Status	Unit
Operating conditions	Normal conditions	
Uplink signal	multi-code	
Information bit rate	2*384	kbps
Power control step size	1	dB

5.13.2.4.2 Procedure

- 1) Set and send continuously Up power control commands to the UE until the UE output power shall be maximum level.
- 2) Measure the Peak code Domain error using Global In-Channel Tx-Test (annex B).
- 3) Set the power level of UE to -18dBm or send Down power control commands (1dB step size should be used.) to the UE until UE output power shall be -18dBm with ± 2 dB tolerance.
- 4) Repeat step 2).

5.13.2.5 Test requirements

The measured Peak code domain error, derived in step 2) and 4), shall not exceed -14 dB.

NOTE: If the above Test Requirement differs from the Minimum Requirement then the Test Tolerance applied for this test is non-zero. The Test Tolerance for this test is defined in clause F.2 and the explanation of how the Minimum Requirement has been relaxed by the Test Tolerance is given in clause F.4

5.13.2A Relative Code Domain Error with HS-DPCCH

5.13.2A.1 Definition and applicability

The Relative Code Domain Error is computed by projecting the error vector (as defined in TS 25.101 [1] 6.8.2) onto the code domain. Only the code channels with non-zero betas in the composite reference waveform are considered for this requirement. The Relative Code Domain Error for every non-zero beta code in the domain is defined as the ratio of the mean power of the projection onto that non-zero beta code, to the mean power of the non-zero beta code in the composite reference waveform. This ratio is expressed in dB. The measurement interval is one timeslot except when the mean power between slots is expected to change whereupon the measurement interval is reduced by 25 μ s at each end of the slot.

The Relative Code Domain Error is affected by both the spreading factor and beta value of the various code channels in the domain. The Effective Code Domain Power (ECDP) is defined to capture both considerations into one parameter. It uses the Nominal CDP ratio (as defined in TS25101 [1] 6.2.3), and is defined as follows for each used code, k, in the domain:

$$ECDP_k = (\text{Nominal CDP ratio})_k + 10 \cdot \log_{10}(SF_k/256)$$

The requirements for Relative Code Domain Error are not applicable when either or both the following channel combinations occur:

- when the ECDP of any code channel is < -30dB.
- when the nominal code domain power of any code channel is < -20 dB

The requirement for Relative Code Domain Error also does not apply for the PRACH preamble and message parts.

The requirements apply for Release 6 and later releases to all types of UTRA for the FDD UE. This test applies only to UE that support HSDPA.

5.13.2A.2 Minimum Requirements

The Relative Code Domain Error shall meet the requirements in Table 5.13.2A.1 for the parameters specified in table 5.13.2A.2.

Table 5.13.2A.1: Relative Code Domain Error minimum requirement

ECDP dB	Relative Code Domain Error dB
-21 < ECDP	≤ -16
-30 \leq ECDP \leq -21	$\leq -37 - \text{ECDP}$
ECDP < -30	No requirement

Table 5.13.2A.2: Parameters for Error Vector Magnitude/Peak Code Domain Error

Parameter		Unit	Level
UE Output Power		dBm	≥ -20
Operating conditions			Normal conditions
Power control step size		dB	1
Measurement period (Note 1)	PRACH	Chips	3904
	Any DPCH		From 1280 to 2560 (Note 2)
Note 1: Less any 25 μ s transient periods			
Note 2: The longest period over which the nominal power remains constant			

The normative reference for this requirement is TS 25.101 [1] clause 6.8.3a.

5.13.2A.3 Test purpose

To verify that the Relative Code Domain Error does not exceed the values in table 5.13.2A.5 for the beta values defined in table 5.13.2A.4.

5.13.2A.4 Method of test

5.13.2A.4.1 Initial conditions

Test environment: normal; see clauses G.2.1 and G.2.2.

Frequencies to be tested: low range, mid range, high range; see clause G.2.4.

- 1) Connect the SS (node B emulator) to the UE antenna connector as shown in figure A.1.
- 2) The UL Reference Measurement Channel and the Fixed Reference Channels (FRC H-Set 1, QPSK version) are specified in Annex C.10.1 and C.8.1.1 with the beta values set according to table C.10.1.4.
- 3) An HSDPA call is set up according to TS 34.108 [3] clause 7.3.6. RF parameters are set up according to table E.5.1 and table E.5.10. Settings for the serving cell are defined in table 5.13.2A.3.
- 4) Enter the UE into loopback test mode in the presence of HSDPA and start the loopback test.

See TS 34.108 [3] and TS 34.109 [4] for details regarding loopback test mode for HSDPA.

Table 5.13.2A.3: Settings for the serving cell during the measurement of Relative Code Domain Error with HS-DPCCH

Parameter	Unit	Cell 1
Cell type		Serving cell
UTRA RF Channel Number		As defined in clause 5.2A.4.1
Qqualmin	dB	-24
Qrxlevmin	dBm	-115
UE_TXPWR_MAX_RACH	dBm	+21
I_{or} (see notes 1 and 2)	dBm/3.84 MHz	-86
NOTE 1: The power level is specified in terms of I_{or} instead of CPICH_RSCP because RSCP is a receiver measurement, whereas the SS can only set I_{or} .		
NOTE 2: The cell fulfils TS 25.304, 5.2.3.1.2.		

5.13.2A.4.2 Procedure

- 1) Set and send continuously Up power control commands to the UE and wait until the UE has reached maximum power.
- 2) Send TRANSPORT CHANNEL RECONFIGURATION message to set the beta values according to table C.10.1.4 sub test 1 and the DPCCH frame offset according the HS-DPCCH slot offset required for measurements.
- 3) Start transmitting HSDPA Data.
- 4) Measure the Relative Code Domain Error of the DPCCH, DPDCH and HS-DPCCH.
- 5) Repeat step 4 for the other combinations of beta values as given in table 5.13.2A.4.
- 6) Set the power level of UE to -18 dBm or send Down power control commands (1dB step size should be used.) to the UE until UE output power shall be -18 dBm with ± 2 dB tolerance.
- 7) Repeat step 4 for all the combinations of beta values as given in table 5.13.2A.4.

All messages indicated above shall use the same content as described in the default message content in clause 9 of TS 34.108 [3], except the TRANSPORT CHANNEL RECONFIGURATION message which is defined in Annex I.

5.13.2A.5 Test requirements

For the ECDP of each code measured in step 4 the Relative Code Domain Error shall not exceed the value given in table 5.13.2A.5.

Table 5.13.2A.4: Nominal ECDP ratios

Sub-test in table C.10.1.4	Code	Nominal Code Domain Power	Spreading factor	Nominal ECDP
1	DPCCH	-17.9	256	-17.9
	DPDCH	-0.4	64	-6.4
	HS-DPCCH	-11.8	256	-11.8
3	DPCCH	-7.2	256	-7.2
	DPDCH	-12.7	64	-18.7
	HS-DPCCH	-1.2	256	-1.2
4	DPCCH	-7.1	256	-7.1
	DPDCH	-18.5	64	-24.5
	HS-DPCCH	-1	256	-1

NOTE: The nominal ECDP ratios given above are calculated from the nominal beta factors and are for general information to indicate the test coverage. The actual ECDP to use in the test for each code shall be based on the measured code domain power. The accuracy of the code domain powers is tested separately in 5.2C.

Table 5.13.2A.5: Relative Code Domain Error test requirement

ECDP dB	Relative Code Domain Error dB
$-21 < \text{ECDP}$	≤ -15.5
$-30 \leq \text{ECDP} \leq -21$	$\leq -36.5 - \text{ECDP}$
$\text{ECDP} < -30$	No requirement

NOTE: If the above Test Requirement differs from the Minimum Requirement then the Test Tolerance applied for this test is non-zero. The Test Tolerance for this test is defined in clause F.2 and the explanation of how the Minimum Requirement has been relaxed by the Test Tolerance is given in clause F.4.

5.13.2B Relative Code Domain Error with HS-DPCCH and E-DCH

5.13.2B.1 Definition and applicability

The Relative Code Domain Error is computed by projecting the error vector (as defined in TS 25.101 [1] 6.8.2) onto the code domain. Only the code channels with non-zero betas in the composite reference waveform are considered for this requirement. The Relative Code Domain Error for every non-zero beta code in the domain is defined as the ratio of the mean power of the projection onto that non-zero beta code, to the mean power of the non-zero beta code in the composite reference waveform. This ratio is expressed in dB. The measurement interval is one timeslot except when the mean power between slots is expected to change whereupon the measurement interval is reduced by 25 μ s at each end of the slot.

The Relative Code Domain Error is affected by both the spreading factor and beta value of the various code channels in the domain. The Effective Code Domain Power (ECDP) is defined to capture both considerations into one parameter. It uses the Nominal CDP ratio (as defined in TS25101 [1] 6.2.3), and is defined as follows for each used code, k, in the domain:

$$\text{ECDP}_k = (\text{Nominal CDP ratio})_k + 10 \cdot \log_{10}(\text{SF}_k/256)$$

The requirements for Relative Code Domain Error are not applicable when either or both of the following channel combinations occur:

- when the ECDP of any code channel is < -30 dB.

- when the nominal code domain power of any code channel is < -20 dB

The requirement for Relative Code Domain Error also does not apply for the PRACH preamble and message parts.

The requirements apply for Release 6 and later releases to all types of UTRA for the FDD UE. This test applies only to UE that support HSDPA and E-DCH.

5.13.2B.2 Minimum Requirements

The Relative Code Domain Error shall meet the requirements in Table 5.13.2B.1 for the parameters specified in Table 5.13.2B.2.

Table 5.13.2B.1: Relative Code Domain Error minimum requirement

ECDP dB	Relative Code Domain Error dB
$-21 < \text{ECDP}$	≤ -16
$-30 \leq \text{ECDP} \leq -21$	$\leq -37 - \text{ECDP}$
$\text{ECDP} < -30$	No requirement

Table 5.13.2B.2: Parameters for Relative Code Domain Error with HS-DPCCH and E-DCH

Parameter		Unit	Level
UE Output Power		dBm	≥ -20
Operating conditions			Normal conditions
Power control step size		dB	1
Measurement period (Note 1)	PRACH	Chips	3904
	Any DPCH		From 1280 to 2560 (Note 2)
Note 1: Less any 25 μ s transient periods			
Note 2: The longest period over which the nominal power remains constant			

The normative reference for this requirement is TS 25.101 [1] clause 6.8.3a.

5.13.2B.3 Test purpose

To verify that the Relative Code Domain Error does not exceed the values in table 5.13.2B.9 for the beta values defined in table 5.13.2B.8.

5.13.2B.4 Method of test

5.13.2B.4.1 Initial conditions

Test environment: normal; see clauses G.2.1 and G.2.2.

Frequencies to be tested: low range, mid range, high range; see clause G.2.4.

- 1) Connect the SS (node B emulator) to the UE antenna connector as shown in figure A.1.
- 2) The UL Reference Measurement Channel and the Fixed Reference Channels (FRC H-Set 1, QPSK) are specified in Annex C.11.1 and C.8.1.1.
- 3) An E-DCH call is set up according to TS 34.108 [3] 7.3.9, with the following exceptions in the RADIO BEARER SETUP messages. These exceptions allow the beta values to be set according to table C.11.1.3 and each UL physical channel to be at constant power at the start of the measurement. RF parameters are set up according to table E.5A.1. Settings for the serving cell are defined in table 5.13.2B.7.
- 4) Enter the UE into loopback test mode 1 looping back both the 12.2kbps RMC and HSDPA to E-DCH and start the loopback test.

See TS 34.109 [4] clauses 5.3.2.3 and 5.3.2.6 for details regarding loopback test mode for HSDPA and E-DCH.

Table 5.13.2B.3: Contents of RADIO BEARER SETUP message: AM or UM (Test Loop Mode1)

Information Element	Value/Remark
UL Transport channel information for all transport channels <ul style="list-style-type: none"> - 2bit CTFC - Power offset Information - CHOICE Gain Factors - CHOICE mode - Gain factor β_c - Gain factor β_d 	3 Signalled Gain Factors FDD Value used in test: see Table C.11.1.3 Value used in test: see Table C.11.1.3
Note: All other 2 bit CTFC values use computed gain factors as in the default message	

Table 5.13.2B.4: Contents of RADIO BEARER SETUP message: AM or UM (E-DCH and HSDPA) for Sub-tests 1,2,4

Information Element	Value/Remark
E-DCH info <ul style="list-style-type: none"> - E-DPDCH info - Reference E-TFCIs - Reference E-TFCI - Reference E-TFCI PO - Reference E-TFCI - Reference E-TFCI PO - Reference E-TFCI - Reference E-TFCI PO - Reference E-TFCI - Reference E-TFCI PO - Reference E-TFCI - Reference E-TFCI PO 	Uplink DPCH info 5 E-TFCIs 11 4 67 18 71 23 75 26 81 27

Table 5.13.2B.5: Contents of RADIO BEARER SETUP message: AM or UM (E-DCH and HSDPA) for Sub-test 3

Information Element	Value/Remark
E-DCH info <ul style="list-style-type: none"> - E-DPDCH info - Reference E-TFCIs - Reference E-TFCI - Reference E-TFCI PO - Reference E-TFCI - Reference E-TFCI PO 	Uplink DPCH info 2 E-TFCIs 11 4 92 18

Table 5.13.2B.6: Contents of RADIO BEARER SETUP message: AM or UM (E-DCH and HSDPA)

Information Element	Value/Remark
CHOICE channel requirement - Power Control Algorithm - Δ_{ACK}	Uplink DPCH info Algorithm2 Value used in test: see Table C.11.1.3
- Δ_{NACK}	Value used in test: see Table C.11.1.3
- Ack-Nack repetition factor	3 (required for continuous HS-DPCCH signal)
E-DCH info	
- E-DPCCH/DPCCH power offset	Value used in test: see Table C.11.1.3
Downlink HS-PDSCH Information	
- Measurement Feedback Info	
- CQI Feedback cycle, k	4 ms
- CQI repetition factor	2 (required for continuous HS-DPCCH signal)
- Δ_{CQI}	Value used in test: see Table C.11.1.3

Table 5.13.2B.7: Settings for the serving cell during the measurement of Relative Code Domain Error with HS-DPCCH and E-DCH

Parameter	Unit	Cell 1
Cell type		Serving cell
UTRA RF Channel Number		As defined in clause 5.13.2B.4.1
Qqualmin	dB	-24
Qrxlevmin	dBm	-115
UE_TXPWR_MAX_RACH	dBm	+21
I_{or} (see notes 1 and 2)	dBm/3.84 MHz	-86
NOTE 1: The power level is specified in terms of I_{or} instead of CPICH_RSCP because RSCP is a receiver measurement, whereas the SS can only set I_{or} .		
NOTE 2: The cell fulfils TS 25.304, 5.2.3.1.2.		

5.13.2B.4.2 Procedure

- 1) Set UE to maximum output power according to 5.2.B.4.2 steps 1 to 8.
- 2) Measure the Relative Code Domain Error of the DPCCH, DPDCH, HS-DPCCH, E-DPCCH and E-DPDCH(s).
- 3) Repeat steps 1 through 2 for the other combinations of beta values as given in Table C.11.1.3.
- 4) Set the power level of UE to -18 dBm or send Down power control commands (1 dB step size should be used) to the UE until UE output power shall be -18 dBm with ± 2 dB tolerance.
- 5) Measure the Relative Code Domain Error of the DPCCH, DPDCH, HS-DPCCH, E-DPCCH and E-DPDCH(s).
- 6) Repeat steps 4 and 5 for all the combinations of beta values for sub-tests 1, 2, 3, and 4 as given in Table C.11.1.3.

5.13.2B.5 Test requirements

For the ECDP of each code measured in steps 2 and 5 the Relative Code Domain Error shall not exceed the value given in table 5.13.2B.9.

Table 5.13.2B.8: Nominal ECDP ratios

Sub-Test in Table C.11.1.3	Code	Nominal Code Domain Power	Spreading Factor	Nominal ECDP
1	DPCCH	-18.5	256	-18.5
	DPDCH	-15.8	64	-21.8
	HS-DPCCH	-12.5	256	-12.5
	E-DPCCH	-16.5	256	-16.8
	E-DPDCH	-0.5	4	-18.6
2	DPCCH	-14.0	256	-13.9
	DPDCH	-6.0	64	-11.9
	HS-DPCCH	-8.0	256	-7.8
	E-DPCCH	-8.0	256	-8.8
	E-DPDCH	-4.1	4	-22.0
3	DPCCH	-14.6	256	-15.2
	DPDCH	-19.1	64	-25.6
	HS-DPCCH	-8.6	256	-9.2
	E-DPCCH	-8.6	256	-6.2
	E-DPDCH1	-4.7	4	-23.4
	E-DPDCH2	-4.7	4	-23.4
4	DPCCH	-19.7	256	-19.7
	DPDCH	-2.2	64	-8.2
	HS-DPCCH	-13.7	256	-13.7
	E-DPCCH	-19.7	256	-19.4
	E-DPDCH	-4.7	4	-22.9

NOTE: The nominal ECDP ratios given above are calculated from the nominal beta factors and are for general information to indicate the test coverage. The actual ECDP to use in the test for each code shall be based on the measured code domain power. The accuracy of the code domain powers is tested separately in 5.2D.

Table 5.13.2B.9: Relative Code Domain Error test requirement

ECDP dB	Relative Code Domain Error dB
$-21 < \text{ECDP}$	≤ -15.5
$-30 \leq \text{ECDP} \leq -21$	$\leq -36.5 - \text{ECDP}$
$\text{ECDP} < -30$	No requirement

NOTE: If the above Test Requirement differs from the Minimum Requirement then the Test Tolerance applied for this test is non-zero. The Test Tolerance for this test is defined in clause F.2 and the explanation of how the Minimum Requirement has been relaxed by the Test Tolerance is given in clause F.4.

5.13.3 UE phase discontinuity

5.13.3.1 Definition and applicability

Phase discontinuity is the change in phase between any two adjacent timeslots. The EVM for each timeslot (excluding the transient periods of 25 μs on either side of the nominal timeslot boundaries) shall be measured according to subclause 5.13.2. The frequency, absolute phase, absolute amplitude and chip clock timing used to minimise the error vector are chosen independently for each timeslot. The phase discontinuity result is defined as the difference between the absolute phase used to calculate EVM for the preceding timeslot, and the absolute phase used to calculate EVM for the succeeding timeslot.

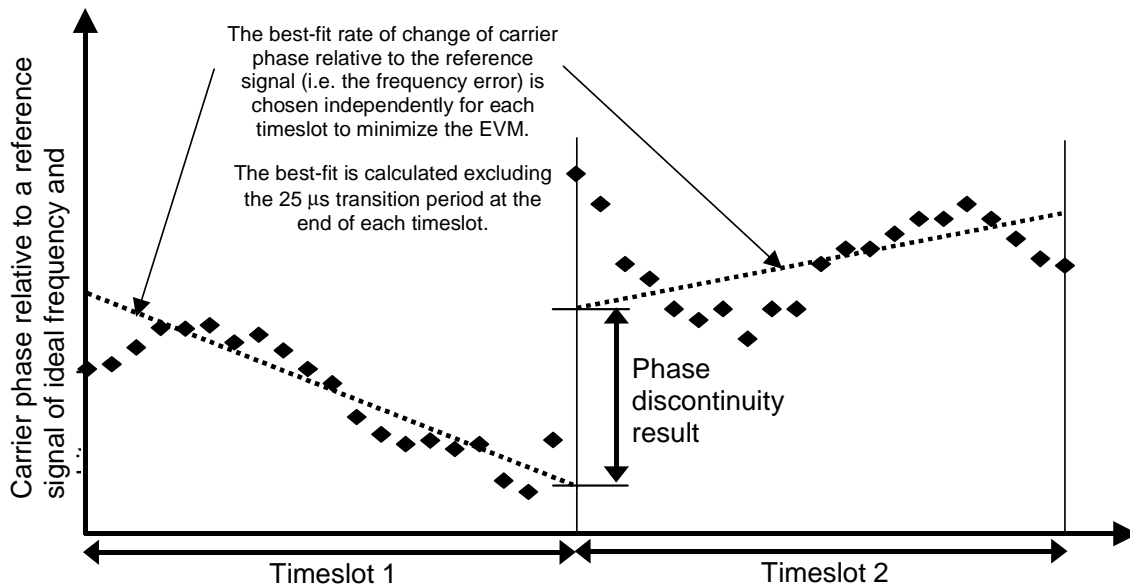

Figure 5.13.3.1 Graphical description of phase discontinuity

The best-fit rate of change of phase for each timeslot is calculated using the same process as used to minimize the EVM. This best-fit rate of change of phase is by definition the frequency error result for the timeslot. Due to the presence of power steps in the test, the data used for the best-fit calculation shall exclude the 25μs transition period at the beginning and end of each timeslot. The best-fit rate of change of phase for each timeslot is then extrapolated in both directions onto the timeslot boundaries. The phase discontinuity result at any one slot boundary is the difference between the extrapolated phase at the end of the timeslot preceding the slot boundary and the extrapolated phase at the start of the timeslot following the slot boundary.

The requirements and this test apply to all types of UTRA for the FDD UE for Release 5 and later releases.

5.13.3.2 Minimum requirements

The rate of occurrence of any phase discontinuity on an uplink DPCH for the parameters specified in table 5.13.1 shall not exceed the values specified in table 5.13.2. Phase shifts that are caused by changes of the UL transport format combination (TFC) and compressed mode are not included. When calculating the phase discontinuity, the requirements for frequency error and EVM in subclauses TS 25.101 [1] 6.3 and TS 25.101 [1] 6.8.2 for each timeslot shall be met.

Table 5.13.1: Parameters for Phase discontinuity

Parameter	Unit	Level
Power control step size	dB	1

Table 5.13.2: Phase discontinuity minimum requirement

Phase discontinuity $\Delta\theta$ in degrees	Maximum allowed rate of occurrence in Hz
$\Delta\theta \leq 30$	1500
$30 < \Delta\theta \leq 60$	300
$\Delta\theta > 60$	0

The normative reference for this requirement is TS 25.101 [1] clause 6.8.4.

5.13.3.3 Test purpose

To verify that the UE phase discontinuity is within the limits shown in clause 5.13.3.2.

To verify that any timeslot used in the calculation of a phase discontinuity result also passes the frequency error and EVM requirements referenced in clause 5.3.2 and 5.13.3.2.

5.13.3.4 Method of test

5.13.3.4.1 Initial conditions

Test environment: normal; see clauses G.2.1 and G.2.2.

Frequencies to be tested: mid range; see clause G.2.4.

- 1) Connect the SS to the UE antenna connector as shown in figure A.1.
- 2) A call is set up according to the Generic call setup procedure using power control algorithm 1 as specified in TS34.108 [3] sub clause 7.3.2.
- 3) Enter the UE into loopback test mode and start the loopback test.

See TS 34.108 [3] and TS 34.109 [4] for details regarding generic call setup procedure and loopback test.

Procedure

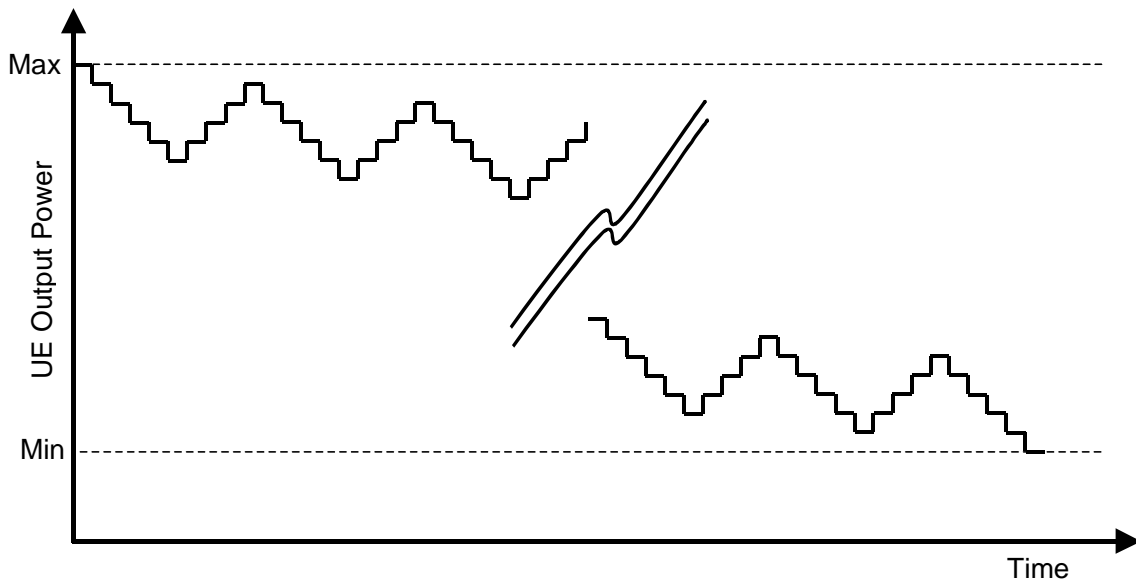

Figure 5.13.3.4 Five down four up hysteresis test pattern

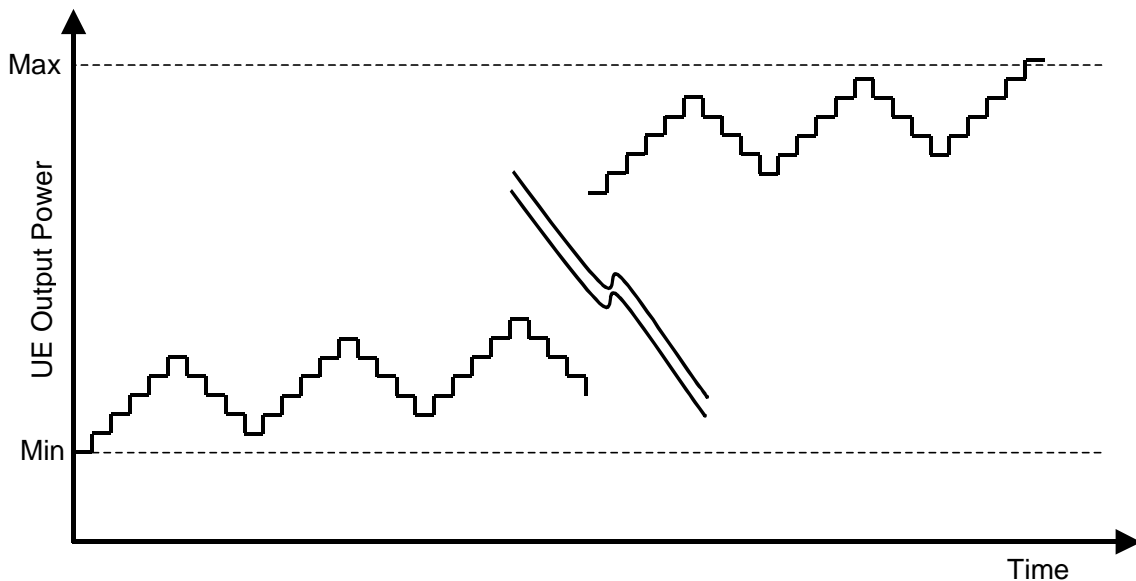

Figure 5.13.3.5 Five up four down hysteresis test pattern

- 1) Set the power of the UE to max power using continuous up TPC commands.
- 2) Transmit a sequence of five down four up TPC commands as shown in figure 5.13.3.4 until the UE has reached the minimum power defined in 5.4.3 with ± 2 dB tolerance.
- 3) During step 2 starting with the slot before the first down power step, measure the EVM of each slot and the phase discontinuity to the next slot.
- 4) Transmit a sequence of five up four down TPC commands as shown in figure 5.13.3.5 until the UE has reached its maximum power defined in 5.2 with ± 2 dB tolerance.
- 5) During step 4 starting with the slot before the first up power step, measure the EVM of each slot and the phase discontinuity to the next slot.

NOTE: In order to make it practical to measure the entire power control dynamic range (between min power threshold and max power threshold with suitable margins), it is permissible to segment the power control sequences into smaller subsequences. Except when within 5 dB of the upper or lower thresholds, segmentation will require sufficient overlap such that every power step in one direction is followed by four steps in the other direction.

5.13.3.5 Test requirements

- a) During 5.13.3.4.2 step 3, and step 5, the EVM of every measured slot which is greater than or equal to -20 dBm shall not exceed 17.5%
- b) During 5.13.3.4.2 step 3, and step 5, the Frequency error of every measured slot shall not exceed $\pm(0,1 \text{ ppm} + 10 \text{ Hz})$.
- c) During 5.13.3.4.2 step 3, and step 5; the phase discontinuity measurements made between any two adjacent slots shall be less than or equal to 36 degrees. If a phase discontinuity measurement is greater than 36 degrees and less than or equal to 66 degrees then the next four measurements shall be less than or equal to 36 degrees. No measurement shall exceed 66 degrees.

NOTE: If the above Test Requirement differs from the Minimum Requirement then the Test Tolerance applied for this test is non-zero. The Test Tolerance for this test is defined in clause F.2 and the explanation of how the Minimum Requirement has been relaxed by the Test Tolerance is given in clause F.4.

5.13.4 PRACH preamble quality

5.13.4.1 Definition and applicability

PRACH preamble quality is a measure of the ability of the UE to transmit the PRACH preamble in accordance with the core requirements so that the Node B can reliably decode the PRACH.

This test applies to all types of UTRA for the FDD UE from Release 5 onwards.

5.13.4.2 Minimum requirements

The EVM of the PRACH preamble observed over the interval of 3904 chips (i.e. excluding the transient periods) shall not exceed 17.5%.

The reference for this requirement is TS 25.101 [1] clause 6.8.2.

The UE modulated carrier frequency used to transmit the PRACH preamble observed over the interval of 3904 chips (i.e. excluding the transient periods) shall be within ± 0.1 PPM compared to the carrier frequency received from the Node B.

The reference for this requirement is TS 25.101 [1] clause 6.3.

The PRACH preamble shall be transmitted in the correct access slot using the correct signature as defined by the parameters signalled to the UE.

The reference for this requirement is TS 25.214 [5] clause 6.1 physical random access procedure.

5.13.4.3 Test purpose

The test purpose is to verify that the transmission quality of the first PRACH preamble meets the minimum requirements for modulation quality, carrier frequency, access slot and signature as defined in 5.13.4.2. The UE is tested at nominal maximum output power and nominally 5.6 dB to 8.6 dB above reference sensitivity, which simulates operation towards the cell boundary. The access slot and signature are chosen randomly from the allowed possibilities for each execution of the RACH procedure. There are 384 possible configurations that could be chosen, but only 10 of these are randomly selected for test in order to minimize the test time.

5.13.4.4 Method of test

5.13.4.4.1 Initial conditions

Test environment: normal, TL/VL, TL/VH, TH/VL, TH/VH; see clauses G.2.1 and G.2.2.

Frequencies to be tested: low range, mid range, high range; see clause G.2.4.

- 1) Connect the SS to the UE antenna connector as shown in figure A.1.
- 2) A call is set up according to the Generic call setup procedure, using the modified parameters according to table 5.13.4.1 and table 5.13.4.2. The relative power levels of the downlink physical channels to I_{OR} are set up according to clause E.2.1. The physical random access procedure within the call setup is used for the test.

See TS 34.108 [3] for details regarding generic call setup procedure and 25.214 [5] for details of the physical random access procedure.

Table 5.13.4.1: Static test parameters for PRACH quality

Static Parameters	Power Class 1	Power Class 2	Power Class 3	Power Class 4	Unit
\hat{I}_{or}	-98.1	-98.1	-98.1	-98.1	dBm / 3,84 MHz
Nominal CPICH_RSCP	-102	-102	-102	-102	dBm
Primary CPICH TX power	+24	+24	+24	+24	dBm
Simulated path loss = Primary CPICH TX power – CPICH_RSCP	+126	+126	+126	+126	dB
UL interference	-83	-89	-92	-95	dBm
Constant Value	-10	-10	-10	-10	dB
Expected nominal UE TX power ¹	+33	+27	+24	+21	dBm
Preamble Retrans Max	1				
NOTE 1: The Expected nominal UE TX power is calculated by using the equation in the clause 8.5.7 Open Loop Power Control of TS 25.331 [8].					

Table 5.13.4.2: Random test parameters for PRACH quality

Random Parameters ¹	Value
Available RACH Sub Channels	One sub-channel chosen at random from the 12-bit Available sub channel number
Available PRACH Signatures	One signature chosen at random from the 16-bit Available signature number
ASC Setting	Both Available signature Start Index and Available signature End Index are 0
AICH transmission timing	Chosen at random from the range 0 to 1
NOTE 1: In order to avoid a static test configuration, each time the RACH procedure is executed, the parameters in this table are to be chosen at random from the defined range. The random function used shall be such that each of the allowed selections is chosen with equal probability.	

Table 5.13.4.3: PAGING TYPE 1 Message content

Information Element	Value/remark
BCCH modification info	
MIB Value Tag	Set to the same value as the value tag of the MIB after the BCCH modification
BCCH Modification time	Not present

5.13.4.4.2 Procedure

- 1) Set the TX output level of the SS to obtain \hat{I}_{or} at the UE antenna connector. \hat{I}_{or} shall be according to table 5.13.4.1 depending on the power class of the UE.
- 2) The SS shall initiate a call by sending PAGING TYPE 1 message and measure the first RF transmission from the UE.
- 3) The SS shall determine the access slot used, the received signature, the EVM and the frequency error.
- 4) Choose a new set of parameters from table 5.13.4.2
- 5) Send PAGING TYPE 1 message with BCCH modification info as per table 5.13.4.3.
- 6) Wait 5seconds to allow the UE to read the new SIB 5.
- 7) Repeat from step number 2) ten times.

5.13.4.5 Test requirements

For all the transmitted PRACH preambles measured in 5.13.4.4.2 step 3:

- 1) The EVM shall not exceed 17,5 %.
- 2) The frequency error shall not exceed $\pm(0,1 \text{ ppm} + 10 \text{ Hz})$.

- 3) The detected access slot and signature shall be correct according to the physical random access procedure defined in [5].

NOTE: If the above Test Requirement differs from the Minimum Requirement then the Test Tolerance applied for this test is non-zero. The Test Tolerance for this test is defined in clause F.2 and the explanation of how the Minimum Requirement has been relaxed by the Test Tolerance is given in clause F.4.

6 Receiver Characteristics

6.1 General

Receiving performance test of the UE is implemented during communicating with the SS via air interface. The procedure is using normal call protocol until the UE is communicating on traffic channel basically. On the traffic channel, the UE provides special function for testing that is called Logical Test Interface and the UE is tested using this function (Refer to TS 34.109 [4])

Transmitting or receiving bit/symbol rate for test channel is shown in table 6.1.

Table 6.1: Bit / Symbol rate for Test Channel

Type of User Information	User bit rate	DL DPCH symbol rate	UL DPCH bit rate	Remarks
12,2 kbps reference measurement channel	12,2 kbps	30 ksps	60 kbps	Standard Test

Unless otherwise stated the receiver characteristics are specified at the antenna connector of the UE. For UE(s) with an integral antenna only, a reference antenna with a gain of 0 dBi is assumed. UE with an integral antenna may be taken into account by converting these power levels into field strength requirements, assuming a 0 dBi gain antenna. For UEs with more than one receiver antenna connector the AWGN signals applied to each receiver antenna connector shall be uncorrelated. The levels of the test signals applied to each of the antenna connectors shall be as defined in the respective sections below. The UE antenna performance has a significant impact on system performance, and minimum requirements on the antenna efficiency are therefore intended to be included in future versions of the present document. It is recognised that different requirements and test methods are likely to be required for the different types of UE.

With the exception of clause 6.8, all the parameters in clause 6 are defined using the DL reference measurement channel (12,2 kbps) specified in clause C.3.1 and unless stated otherwise, with DL power control OFF.

The common RF test conditions of Rx Characteristics are defined in clause E.3.2, and each test conditions in this clause (clause 6) should refer clause E.3.2. Individual test conditions are defined in the paragraph of each test.

When DCCH has been configured on downlink DCH then DCCH Data shall be continuously transmitted on downlink DCH during the measurement period. When there is no signalling to transmit on downlink DCCH then dummy DCCH transmission as described in Annex C.9 shall be used.

For HSDPA test cases, when DTCH has been configured on downlink DCH then DTCH Data shall be continuously transmitted on downlink DCH during the measurement period.

All Bit Error ratio (BER) measurements in clause 6 shall be performed according to the general rules for statistical testing in Annex F.6.

For HSDPA test cases without E-DCH, the MAC headers on HS-DSCH shall be according to Annex C.9A.

6.2 Reference Sensitivity Level

6.2.1 Definition and applicability

The reference sensitivity level <REFSENS> is the minimum mean power received at the UE antenna port at which the Bit Error Ratio (BER) shall not exceed a specific value

The requirements and this test apply to all types of UTRA for the FDD UE.

6.2.2 Minimum Requirements

The BER shall not exceed 0,001 for the parameters specified in table 6.2.1.

Table 6.2.1: Test parameters for Reference Sensitivity Level

Operating Band	Unit	DPCH_Ec <REFSENS>	<REF _{or} >
I	dBm/3.84 MHz	-117	-106.7
II	dBm/3.84 MHz	-115	-104.7
III	dBm/3.84 MHz	-114	-103.7
IV	dBm/3.84 MHz	-117	-106.7
V	dBm/3.84 MHz	-115	-104.7
VI	dBm/3.84 MHz	-117	-106.7
VII	dBm/3.84 MHz	-115	-104.7
VIII	dBm/3.84 MHz	-114	-103.7
IX	dBm/3.84 MHz	-116	-105.7
X	dBm/3.84 MHz	-117	-106.7
XI	dBm/3.84 MHz	-115	-104.7
1.	For Power class 3 this shall be at the maximum output power		
2.	For Power class 4 this shall be at the maximum output power		
3.	For the UE which supports both Band III and Band IX operating frequencies, the reference sensitivity level of -114.5 dBm DPCH_Ec <REFSENS> shall apply for Band IX. The corresponding <REF _{or} > is -104.2 dBm		

The normative reference for this requirement is TS 25.101 [1] clause 7.3.1.

6.2.3 Test purpose

To verify that the UE BER shall not exceed 0,001 for the parameters specified in table 6.2.1.

The lack of the reception sensitivity decreases the coverage area at the far side from Node B.

6.2.4 Method of test

6.2.4.1 Initial conditions

Test environment: normal, TL/VL, TL/VH, TH/VL, TH/VH; see clauses G.2.1 and G.2.2.

Frequencies to be tested: low range, mid range, high range; see clause G.2.4.

- 1) Connect the SS to the UE antenna connector as shown in figure A.1.
- 2) Channel conditions are initially set up with received CPICH_RSCP >-85 dBm. The relative power level of downlink physical channels to I_{or} are set up according to clause E.2.1. The parameter settings of the cell are set up according to TS 34.108 [3], clause 6.1.5 for "Default settings for a serving cell in a single cell environment".
- 3) Switch on the phone.
- 4) A call is set up according to the Generic call setup procedure in TS34.108 [3] sub clause 7.3.2.
- 5) The RF parameters are set up according to table 6.2.2.
- 6) Enter the UE into loopback test mode and start the loopback test.

See TS 34.109 [4] for details regarding loopback test.

6.2.4.2 Procedure

- 1) Set and send continuously Up power control commands to the UE until the UE output power shall be maximum level.

- 2) Measure the BER of DCH received from the UE at the SS.

6.2.5 Test requirements

The measured BER, derived in step 2), shall not exceed 0,001.

Table 6.2.2: Test parameters for Reference Sensitivity Level

Operating Band	Unit	DPCH_Ec <REFSENS>	<REF _{or} >
I	dBm/3.84 MHz	-116.3	-106
II	dBm/3.84 MHz	-114.3	-104
III	dBm/3.84 MHz	-113.3	-103
IV	dBm/3.84 MHz	-116.3	-106
V	dBm/3.84 MHz	-114.3	-104
VI	dBm/3.84 MHz	-116.3	-106
VII	dBm/3.84 MHz	-114.3	-104
VIII	dBm/3.84 MHz	-113.3	-103
IX	dBm/3.84 MHz	-115.3	-105
X	dBm/3.84 MHz	-116.3	-106
XI	dBm/3.84 MHz	-114.3	-104

1. For Power class 3 this shall be at the maximum output power
2. For Power class 4 this shall be at the maximum output power
3. For the UE which supports both Band III and Band IX operating frequencies, the reference sensitivity level of -113.8 dBm DPCH_Ec <REFSENS> shall apply for Band IX. The corresponding <REF_{or}> is -103.5 dBm

NOTE: If the above Test Requirement differs from the Minimum Requirement then the Test Tolerance applied for this test is non-zero. The Test Tolerance for this test is defined in clause F.2 and the explanation of how the Minimum Requirement has been relaxed by the Test Tolerance is given in clause F.4.

6.3 Maximum Input Level

6.3.1 Definition and applicability

This is defined as the maximum mean power received at the UE antenna port, which shall not degrade the specified BER performance.

The requirements and this test apply to all types of UTRA for the FDD UE.

6.3.2 Minimum requirements

The BER shall not exceed 0.001 for the parameters specified in table 6.3.

The reference for this requirement is TS 25.101 [1] clause 7.4.1.

NOTE: Since the spreading factor is large ($10\log(SF)=21\text{dB}$), the majority of the total input signal consists of the OCNS interference. The structure of OCNS signal is defined in clause E.3.3.

6.3.3 Test purpose

To verify that the UE BER shall not exceed 0,001 for the parameters specified in table 6.3.

An inadequate maximum input level causes loss of coverage near the Node B

6.3.4 Method of test

6.3.4.1 Initial conditions

Test environment: normal; see clauses G.2.1 and G.2.2.

Frequencies to be tested: mid range; see clause G.2.4.

- 1) Connect the SS to the UE antenna connector as shown in figure A.1.

- 2) RF parameters are set up according to table 6.3.3 and table E.3.3.
- 3) A call is set up according to the Generic call setup procedure specified in TS34.108[3] sub clause 7.3.2, with the following exception for information elements in RADIO BEARER SETUP message. With this exception, the Power Control Algorithm for the Uplink is set to algorithm 2.
- 4) Enter the UE into loopback test mode and start the loopback test.

Table 6.3.1 Contents of RADIO BEARER SETUP message: AM or UM

Information Element	Value/Remark
CHOICE channel requirement - Power Control Algorithm	Uplink DPCH info Algorithm2

See TS 34.108 [3] and TS 34.109 [4] for details regarding generic call setup procedure and loopback test.

Table 6.3.2: Test parameters for Maximum Input Level

Parameter	Level / Status	Unit
I_{or}	-25	dBm / 3,84MHz
$\frac{DPCH_E_c}{I_{or}}$	-19	dB
UE transmitted mean power	20 (for Power class 3) 18 (for Power class 4)	dBm

6.3.4.2 Procedure

- 1) Set the power level of UE according to the table 6.3.3 or send the power control commands (1dB step size should be used.) to the UE until UE output power measured by Test System shall be kept at the specified power level with ± 1 dB tolerance.
- 2) Measure the BER of DCH received from the UE at the SS.

6.3.5 Test requirements

The measured BER, derived in step 1), shall not exceed 0,001.

Table 6.3.3: Test requirements for Maximum Input Level

Parameter	Level / Status	Unit
I_{or}	-25.7	dBm / 3,84MHz
$\frac{DPCH_E_c}{I_{or}}$	-19	dB
UE transmitted mean power	20 (for Power class 3) 18 (for Power class 4)	dBm

NOTE: If the above Test Requirement differs from the Minimum Requirement then the Test Tolerance applied for this test is non-zero. The Test Tolerance for this test is defined in clause F.2 and the explanation of how the Minimum Requirement has been relaxed by the Test Tolerance is given in clause F.4.

6.3A Maximum Input Level for HS-PDSCH Reception (16QAM)

6.3A.1 Definition and applicability

Maximum input level for HS-PDSCH reception is defined as the maximum power received at the UE antenna port, which shall not degrade the specified HSDPA throughput performance. The requirements and this test apply to all types of UTRA FDD UE that support HSDPA(16QAM).

6.3A.2 Minimum requirements

The requirements are specified in terms of a minimum information bit throughput R for the DL reference channel H-Set 1 (16QAM version) specified in Annex C.8.1.1 with the addition of the parameters in Table 6.3A.1 and the downlink physical channel setup according to table E.5.1.

Using this configuration the throughput shall meet or exceed the minimum requirements specified in table 6.3A.2.

The reference for this requirement is TS 25.101 [1] clause 7.4.2.

Table 6.3A.1 Minimum requirement parameters for 16QAM Maximum Input Level

Parameter	Unit	Value
Phase reference \hat{I}_{or}	dBm/3.84 MHz	P-CPICH -25 *
UE transmitted mean power	dBm	20 (for Power class 3) 18 (for Power class 4)
DPCH_Ec/I _{or}	dB	-13
HS-SCCH_1_Ec/I _{or}	dB	-13
Redundancy and constellation version		6
Maximum number of HARQ transmissions		1

Note: The HS-SCCH and corresponding HS-PDSCH shall be transmitted continuously with constant power but the HS-SCCH shall only use the identity of the UE under test every third TTI.

Table 6.3A.2 Minimum throughput requirement

HS-PDSCH E_c/I_{or} (dB)	T-put R (kbps)
-3	700

6.3A.3 Test purpose

To verify that the UE HSDPA throughput meets the minimum requirements specified in table 6.3A.2 for the DL reference channel H-Set 1 specified in Annex C.8.1.1 with the addition of the parameters specified in table 6.3A.4.

An inadequate maximum input level causes loss of coverage near the Node B.

6.3A.4 Method of test

6.3A.4.1 Initial conditions

Test environment: normal; see clauses G.2.1 and G.2.2.

Frequencies to be tested: mid range; see clause G.2.4.

RF parameters are given in tables 6.3A.4 and table E.5.1.

Table 6.3A.3 Contents of RADIO BEARER SETUP message: AM or UM

Information Element	Value/Remark
CHOICE channel requirement - Power Control Algorithm	Uplink DPCH info Algorithm2

6.3A.4.2 Procedure

Connect the SS to the UE antenna connector as shown in figure A.1.

- 1) The UE is switched on.
- 2) An RRC connection is set-up according to the generic HSDPA set-up procedure with looping back 12.2kbps RMC specified in TS 34.108 [3] clause 7.3.6. Additional radio bearer message definition is in table 6.3A.3

- 3) Set the power level of UE according to the table 6.3A.4 and send power control commands to the UE .The UE output power measured by Test System shall be kept at the specified power level with ± 1 dB tolerance.
- 4) Measure the HS-PDSCH throughput R received by the UE by counting the number of NACK, ACK and statDTX on the UL HS-DPCCH (Throughput = blocksize*number of blocks acknowledged/time).
- 5) The UE is switched off.

6.3A.5 Test requirements

The measured throughput, as derived in step 4), shall meet or exceed 700Kbit/second. The minimum number of measurements required for a statistically significant result to this test are clarified in annex F.6.3, Table F.6.3.5.1.

Table 6.3A.4: Test requirement parameters for 16QAM Maximum Input Level

Parameter	Unit	Value
Phase reference \hat{I}_{or}	dBm/3.84 MHz	P-CPICH -25.7
UE transmitted mean power		20 (for Power class 3) 18 (for Power class 4)
DPCH_Ec/I _{or}	dB	-13
HS-SCCH_1_Ec/I _{or}	dB	-13
Redundancy and constellation version		6
Maximum number of HARQ transmissions		1

Note: The HS-SCCH and corresponding HS-DSCH shall be transmitted continuously with constant power but the HS-SCCH shall only use the identity of the UE under test every third TTI.

NOTE: If the above Test Requirement differs from the Minimum Requirement then the Test Tolerance applied for this test is non-zero. The Test Tolerance for this test is defined in clause F.2 and the explanation of how the Minimum Requirement has been relaxed by the Test Tolerance is given in clause F.4.

6.4 Adjacent Channel Selectivity (ACS) (Rel-99 and Rel-4)

6.4.1 Definition and applicability

Adjacent Channel Selectivity (ACS) is a measure of a receiver's ability to receive a W-CDMA signal at its assigned channel frequency in the presence of an adjacent channel signal at a given frequency offset from the centre frequency of the assigned channel. ACS is the ratio of the receive filter attenuation on the assigned channel frequency to the receive filter attenuation on the adjacent channel(s).

The requirements and this test apply to all types of UTRA for the FDD UE for Release 99 and Release 4.

6.4.2 Minimum Requirements

For the UE of power class 3 and 4, the BER shall not exceed 0,001 for the parameters specified in table 6.4.1. This test condition is equivalent to the ACS value 33 dB.

Table 6.4.1: Test parameters for Adjacent Channel Selectivity for Release 99 and Release 4.

Parameter	Level / Status	Unit
DPCH_Ec	-103	dBm / 3,84 MHz
\hat{I}_{or}	-92,7	dBm / 3,84 MHz
I_{oac} mean power (modulated)	-52	dBm
F_{uw} (offset)	-5 or +5	MHz
UE transmitted mean power	20 (for Power class 3) 18 (for Power class 4)	dBm

The normative reference for these requirements is TS 25.101 [1] clause 7.5.1.

NOTE: The I_{oac} (modulated) signal consists of the common channels needed for tests as specified in table E.4.1 and 16 dedicated data channels as specified in table E.3.6.

6.4.3 Test purpose

To verify that the UE BER does not exceed 0,001 for the test parameters specified in table 6.4.1.

The lack of the ACS decreases the coverage area when other transmitter exists in the adjacent channel.

6.4.4 Method of test

6.4.4.1 Initial conditions

Test environment: normal; see clauses G.2.1 and G.2.2.

Frequencies to be tested: mid range; see clause G.2.4.

- 1) Connect the SS to the UE antenna connector as shown in figure A.4.
- 2) RF parameters are set up according to table 6.4.2.
- 3) A call is set up according to the Generic call setup procedure specified in TS34.108[3] sub clause 7.3.2, with the following exception for information elements in RADIO BEARER SETUP message. With this exception, the Power Control Algorithm for the Uplink is set to algorithm 2.
- 4) Enter the UE into loopback test mode and start the loopback test.

Table 6.4.1A Contents of RADIO BEARER SETUP message: AM or UM

Information Element	Value/Remark
CHOICE channel requirement - Power Control Algorithm	Uplink DPCH info Algorithm2

See TS 34.108 [3] and TS 34.109 [4] for details regarding generic call setup procedure and loopback test.

6.4.4.2 Procedure

- 1) Set the parameters of the interference signal generator as shown in table 6.4.2.
- 2) Set the power level of UE according to the table 6.4.2 or send the power control commands (1dB step size should be used.) to the UE until UE output power measured by Test System shall be kept at the specified power level with ± 1 dB tolerance.
- 3) Measure the BER of DCH received from the UE at the SS.

6.4.5 Test requirements

The measured BER, derived in step 1), shall not exceed 0,001.

Table 6.4.2: Test parameters for Adjacent Channel Selectivity for Release 99 and Release 4.

Parameter	Level / Status	Unit
DPCH_Ec	-103	dBm / 3,84 MHz
I_{or}	-92,7	dBm / 3,84 MHz
I_{oac} mean power (modulated)	-52	dBm
F_{uw} (offset)	-5 or +5	MHz
UE transmitted mean power	20 (for Power class 3) 18 (for Power class 4)	dBm

NOTE: If the above Test Requirement differs from the Minimum Requirement then the Test Tolerance applied for this test is non-zero. The Test Tolerance for this test is defined in clause F.2 and the explanation of how the Minimum Requirement has been relaxed by the Test Tolerance is given in clause F.4.

6.4A Adjacent Channel Selectivity (ACS) (Rel-5 and later releases)

6.4A.1 Definition and applicability

Adjacent Channel Selectivity (ACS) is a measure of a receiver's ability to receive a W-CDMA signal at its assigned channel frequency in the presence of an adjacent channel signal at a given frequency offset from the centre frequency of the assigned channel. ACS is the ratio of the receive filter attenuation on the assigned channel frequency to the receive filter attenuation on the adjacent channel(s).

The requirements and this test apply to all types of UTRA for the FDD UE for Release 5 and later releases.

6.4A.2 Minimum Requirements

For the UE of power class 3 and 4, the BER shall not exceed 0,001 for the parameters specified in table 6.4A.1. This test condition is equivalent to the ACS value 33 dB.

Table 6.4A.1: Test parameters for Adjacent Channel Selectivity for release 5 and later releases

Parameter	Unit	Case 1	Case 2
DPCH_Ec	dBm/3.84 MHz	<REFSENS> + 14 dB	<REFSENS> + 41 dB
I _{or}	dBm/3.84 MHz	<REFI _{or} > + 14 dB	<REFI _{or} > + 41 dB
I _{oac} mean power (modulated)	dBm	-52	-25
F _{uw} (offset)	MHz	+5 or -5	+5 or -5
UE transmitted mean power	dBm	20 (for Power class 3) 18 (for Power class 4)	20 (for Power class 3) 18 (for Power class 4)

The normative reference for these requirements is TS 25.101 [1] clause 7.5.1.

NOTE: The I_{oac} (modulated) signal consists of the common channels needed for tests as specified in table E.4.1 and 16 dedicated data channels as specified in table E.3.6.

6.4A.3 Test purpose

To verify that the UE BER does not exceed 0,001 for the test parameters specified in table 6.4A.1.

The lack of the ACS decreases the coverage area when other transmitter exists in the adjacent channel.

6.4A.4 Method of test

6.4A.4.1 Initial conditions

Test environment: normal; see clauses G.2.1 and G.2.2.

Frequencies to be tested: mid range; see clause G.2.4.

- 1) Connect the SS to the UE antenna connector as shown in figure A.4.
- 2) RF parameters are set up according to table 6.4A.2.
- 3) A call is set up according to the Generic call setup procedure specified in TS34.108[3] sub clause 7.3.2, with the following exception for information elements in RADIO BEARER SETUP message. With this exception, the Power Control Algorithm for the Uplink is set to algorithm 2.
- 4) Enter the UE into loopback test mode and start the loopback test.

Table 6.4A.1A Contents of RADIO BEARER SETUP message: AM or UM

Information Element	Value/Remark
CHOICE channel requirement - Power Control Algorithm	Uplink DPCH info Algorithm2

See TS 34.108 [3] and TS 34.109 [4] for details regarding generic call setup procedure and loopback test.

6.4A.4.2 Procedure

- 1) Set the parameters of the interference signal generator as shown in table 6.4A.2 case 1.
- 2) Set the power level of UE according to the table 6.4A.2 case 1 or send the power control commands (1dB step size should be used.) to the UE until UE output power measured by Test System shall be kept at the specified power level with ± 1 dB tolerance.
- 3) Measure the BER of DCH received from the UE at the SS.
- 4) Set the parameters of the interference signal generator as shown in table 6.4A.2 case 2.
- 5) Set the power level of UE according to the table 6.4A.2 case 2 or send the power control commands (1dB step size should be used.) to the UE until UE output power measured by Test System shall be kept at the specified power level with ± 1 dB tolerance.
- 6) Measure the BER of DCH received from the UE at the SS.

6.4A.5 Test requirements

The measured BER, derived in step 1), shall not exceed 0,001.

Table 6.4A.2: Test parameters for Adjacent Channel Selectivity for Release 5 and later releases

Parameter	Unit	Case 1	Case 2
DPCH_Ec	dBm/3.84 MHz	<REFSENS> + 14 dB	<REFSENS> + 41 dB
\hat{I}_{or}	dBm/3.84 MHz	<REF \hat{I}_{or} > + 14 dB	<REF \hat{I}_{or} > + 41 dB
I_{oac} mean power (modulated)	dBm	-52	-25
F_{uw} (offset)	MHz	+5 or -5	+5 or -5
UE transmitted mean power	dBm	20 (for Power class 3) 18 (for Power class 4)	20 (for Power class 3) 18 (for Power class 4)

NOTE: If the above Test Requirement differs from the Minimum Requirement then the Test Tolerance applied for this test is non-zero. The Test Tolerance for this test is defined in clause F.2 and the explanation of how the Minimum Requirement has been relaxed by the Test Tolerance is given in clause F.4.

6.5 Blocking Characteristics

6.5.1 Definition and applicability

The blocking characteristic is a measure of the receiver's ability to receive a wanted signal at its assigned channel frequency in the presence of an unwanted interferer on frequencies other than those of the spurious response or the adjacent channels, without this unwanted input signal causing a degradation of the performance of the receiver beyond a specified limit. The blocking performance shall apply at all frequencies except those at which a spurious response occur.

The requirements in clause 6.5.2.1 and 6.5.2.2 and this test apply to all types of UTRA for the FDD UE.

The requirements in clause 6.5.2.3 and this test apply to the FDD UE supporting band II, band III, band IV, band V or Band VIII.

The frequency range 4 requirements do not apply to Release 5 or earlier releases, but only to Release 6 and onwards.

6.5.2 Minimum Requirements

6.5.2.1 Minimum Requirements (In-band blocking)

The BER shall not exceed 0,001 for the parameters specified in table 6.5.1. In-band blocking is defined for an unwanted interfering signal falling into the UE receive band or into the first 15 MHz below or above the UE receive band.

The normative reference for this requirement is TS 25.101 [1] clause 7.6.1.

Table 6.5.1: Test parameters for In-band blocking characteristics

Parameter	Unit	Level	
DPCH_Ec	dBm/3.84 MHz	<REFSENS>+3 dB	
\hat{I}_{or}	dBm/3.84 MHz	<REF \hat{I}_{or} > + 3 dB	
$I_{blocking}$ mean power (modulated)	dBm	-56	-44
F_{uw} offset		± 10 MHz	≤ 15 MHz & ≥ 15 MHz
F_{uw} (Band I operation)	MHz	$2102.4 \leq f \leq 2177.6$ (Note 2)	$2095 \leq f \leq 2185$
F_{uw} (Band II operation)	MHz	$1922.4 \leq f \leq 1997.6$ (Note 2)	$1915 \leq f \leq 2005$
F_{uw} (Band III operation)	MHz	$1797.4 \leq f \leq 1887.6$ (Note 2)	$1790 \leq f \leq 1895$
F_{uw} (Band IV operation)	MHz	$2102.4 \leq f \leq 2162.6$ (Note 2)	$2095 \leq f \leq 2170$
F_{uw} (Band V operation)	MHz	$861.4 \leq f \leq 901.6$ (Note 2)	$854 \leq f \leq 909$
F_{uw} (Band VI operation)	MHz	$867.4 \leq f \leq 892.6$ (Note 2 and 3)	$860 \leq f \leq 900$ (Note 3)
F_{uw} (Band VII operation)	MHz	$2612.4 \leq f \leq 2697.6$ (Note 2)	$2605 \leq f \leq 2705$
F_{uw} (Band VIII operation)	MHz	$917.4 \leq f \leq 967.6$ (Note 2)	$910 \leq f \leq 975$
F_{uw} (Band IX operation)	MHz	$1837.4 \leq f \leq 1887.4$ (Note 2)	$1829.9 \leq f \leq 1894.9$
F_{uw} (Band X operation)	MHz	$2102.4 \leq f \leq 2177.6$ (Note 2)	$2095 \leq f \leq 2185$
F_{uw} (Band XI operation)	MHz	$1468.4 \leq f \leq 1508.4$ (Note 2)	$1460.9 \leq f \leq 1515.9$
UE transmitted mean power	dBm	20 (for Power class 3) 18 (for Power class 4)	

Note 1: $I_{blocking}$ (modulated) consists of the common channels needed for tests as specified in Table E.4.1 and 16 dedicated data channels as specified in Table E.3.6.

Note 2: For each carrier frequency the requirement is valid for two frequencies, the carrier frequency +/- 10 MHz.

Note 3: For Band VI, the unwanted interfering signal does not fall inside the UE receive band, but within the first 15 MHz below or above the UE receive band.

6.5.2.2 Minimum requirements (Out of-band blocking)

The BER shall not exceed 0.001 for the parameters specified in table 6.5.2. Out-of-band band blocking is defined for an unwanted interfering signal falling more than 15 MHz below or above the UE receive band. For table 6.5.2 in frequency range 1, 2 and 3, up to 24 exceptions are allowed for spurious response frequencies in each assigned frequency channel when measured using a 1 MHz step size.

For Table 6.5.2 in frequency range 4, up to 8 exceptions are allowed for spurious response frequencies in each assigned frequency channel when measured using 1 MHz step size.

The normative reference for this requirement is TS 25.101 [1] clause 7.6.2.

Table 6.5.2: Test parameters for Out of band blocking characteristics

Parameter	Unit	Frequency range 1	Frequency range 2	Frequency range 3	Frequency range 4
DPCH_Ec	dBm/3.84 MHz	<REFSENS>+3 dB	<REFSENS>+3 dB	<REFSENS>+3 dB	<REFSENS> +3 dB
\hat{I}_{or}	dBm/3.84 MHz	<REF \hat{I}_{or} > + 3 dB	<REF \hat{I}_{or} > + 3 dB	<REF \hat{I}_{or} > + 3 dB	<REF \hat{I}_{or} > + 3 dB
$I_{blocking}$ (CW)	dBm	-44	-30	-15	-15
F_{uw} (Band I operation)	MHz	2050<f <2095 2185<f <2230	2025 <f ≤2050 2230 ≤f <2255	1 < f ≤2025 2255≤f<12750	-
F_{uw} (Band II operation)	MHz	1870<f <1915 2005<f <2050	1845 <f ≤1870 2050 ≤f <2075	1 < f ≤1845 2075≤f<12750	1850 ≤ f ≤ 1910
F_{uw} (Band III operation)	MHz	1745 <f <1790 1895<f <1940	1720 <f ≤ 1745 1940≤f < 1965	1 < f ≤1720 1965≤f<12750	-
F_{uw} (Band IV operation)	MHz	2050< f <2095 2170< f <2215	2025< f ≤2050 2215≤ f < 2240	1 < f ≤2025 2240≤f<12750	-
F_{uw} (Band V operation)	MHz	809< f <854 909< f <954	784< f ≤809 954≤ f < 979	1 < f ≤784 979≤f<12750	824 ≤ f ≤ 849
F_{uw} (Band VI operation)	MHz	815 < f < 860 900 < f < 945	790 < f ≤ 815 945 ≤ f < 970	1 < f ≤ 790 970 ≤ f < 12750	-
F_{uw} (Band VII operation)	MHz	2570 < f < 2605 2705 < f < 2750	na 2750 ≤ f < 2775	1 < f ≤ 2570 2775 ≤ f < 12750	-
F_{uw} (Band VIII operation)	MHz	865 < f < 910 975 < f < 1020	840 < f ≤ 865 1020 ≤ f < 1045	1 < f ≤ 840 1045 ≤ f < 12750	-
F_{uw} (Band IX operation)	MHz	1784.9 < f < 1829.9 1894.9 < f < 1939.9	1759.9 < f ≤ 1784.9 1939.9 ≤ f < 1964.9	1 < f ≤ 1759.9 1964.9 ≤ f < 12750	-
F_{uw} (Band X operation)	MHz	2050 < f < 2095 2185 < f < 2230	2025 < f ≤ 2050 2230 ≤ f < 2255	1 < f ≤ 2025 2255 ≤ f < 12750	-
F_{uw} (Band XI operation)	MHz	1415.9 < f < 1460.9 1515.9 < f < 1560.9	1390.9 < f ≤ 1415.9 1560.9 ≤ f < 1585.9	1 < f ≤ 1390.9 1585.9 ≤ f < 12750	-
UE transmitted mean power	dBm		20 (for Power class 3) 18 (for Power class 4)		
Band I operation		For 2095≤f ≤2185 MHz, the appropriate in-band blocking or adjacent channel selectivity in clause 6.5.2 and clause 6.4.2 shall be applied.			
Band II operation		For 1915≤f ≤2005 MHz, the appropriate in-band blocking or adjacent channel selectivity in clause 6.5.2 and clause 6.4.2 shall be applied			
Band III operation		For 1790≤f ≤1895 MHz, the appropriate in-band blocking or adjacent channel selectivity in clause 6.5.2 and clause 6.4.2 shall be applied.			
Band IV operation		For 2095≤f ≤2170 MHz, the appropriate in-band blocking or adjacent channel selectivity in clause 6.5.2 and clause 6.4.2 shall be applied.			
Band V operation		For 854≤f ≤909 MHz, the appropriate in-band blocking or adjacent channel selectivity in subclause 6.5.2 and subclause 6.4.2 shall be applied.			
Band VI operation		For 860≤f ≤900 MHz, the appropriate in-band blocking or adjacent channel selectivity in clause 6.5.2 and clause 6.4.2 shall be applied.			
Band VII operation		For 2605 ≤ f ≤ 2705 MHz, the appropriate in-band blocking or adjacent channel selectivity in subclause 6.5.2 and subclause 6.4.2 shall be applied.			
Band VIII operation		For 910 ≤ f ≤ 975 MHz, the appropriate in-band blocking or adjacent channel selectivity in subclause 6.5.2 and subclause 6.4.2 shall be applied.			
Band IX operation		For 1829.9≤f ≤ 1894.9 MHz, the appropriate in-band blocking or adjacent channel selectivity in clause 6.5.2 and clause 6.4.2 shall be applied.			
Band X operation		For 2095 ≤ f ≤ 2185 MHz, the appropriate in-band blocking or adjacent channel selectivity in clause 6.5.2 and clause 6.4.2 shall be applied.			
Band XI operation		For 1460.9 ≤ f ≤ 1515.9 MHz, the appropriate in-band blocking or adjacent channel selectivity in clause 6.5.2 and clause 6.4.2 shall be applied.			

6.5.2.3 Minimum requirements (Narrow band blocking)

The BER shall not exceed 0.001 for the parameters specified in table 6.5.3. This requirement is measure of a receiver's ability to receive a W-CDMA signal at its assigned channel frequency in the presence of an unwanted narrow band interferer at a frequency, which is less than the nominal channel spacing. The requirements and this test apply to UTRA for the FDD UE supporting band II, band III, band IV, band V or band VIII.

The normative reference for this requirement is TS 25.101 [1] clause 7.6.3

Table 6.5.3: Test parameters for narrow band blocking

Parameter	Unit	Band II, IV, V, X	Band III, VIII
DPCH_Ec	dBm/3.84 MHz	<REFSENS> + 10 dB	<REFSENS> + 10 dB
I _{or}	dBm/3.84 MHz	<REFI _{or} > + 10 dB	<REFI _{or} > + 10 dB
I _{blocking} (GMSK)	dBm	-57	-56
F _{uw} (offset)	MHz	2.7	2.8
UE transmitted mean power	dBm	20 (for Power class 3) 18 (for Power class 4)	

NOTE: I_{blocking} (GMSK) is an interfering signal as defined in TS 45.004. It is a continuous GMSK modulated carrier following the structure of the GSM signals, but with all modulating bits (including the midamble period) derived directly from a random or any pseudo random data stream.

6.5.3 Test purpose

To verify that the UE BER does not exceed 0,001 for the parameters specified in table 6.5.1, table 6.5.2 and table 6.5.3. For Table 6.5.2 in frequency range 1, 2 and 3, up to (24) exceptions are allowed for spurious response frequencies in each assigned frequency channel when measured using a 1 MHz step size.

For Table 6.5.2 in frequency range 4, up to 8 exceptions are allowed for spurious response frequencies in each assigned frequency channel when measured using a 1 MHz step size.

The lack of the blocking ability decreases the coverage area when other transmitter exists (except in the adjacent channels and spurious response).

6.5.4 Method of test

6.5.4.1 Initial conditions

For in-band case:

Test environment: normal; see clauses G.2.1 and G.2.2.

Frequencies to be tested: mid range; see clause G.2.4.

For out-of-band case:

Test environment: normal; see clauses G.2.1 and G.2.2.

Frequency to be tested: 1 arbitrary frequency chosen from the low, mid or high range; see clause G.2.4.

For narrow-band case:

Test environment: normal; see clauses G.2.1 and G.2.2.

Frequencies to be tested: mid range; see clause G.2.4.

- 1) Connect the SS to the UE antenna connector as shown in figure A.5.
- 2) RF parameters are set up according to table 6.5.4, table 6.5.5 and table 6.5.6.
- 3) A call is set up according to the Generic call setup procedure specified in TS34.108[3] sub clause 7.3.2, with the following exception for information elements in RADIO BEARER SETUP message. With this exception, the Power Control Algorithm for the Uplink is set to algorithm 2.

- 4) Enter the UE into loopback test mode and start the loopback test.

Table 6.5.3A Contents of RADIO BEARER SETUP message: AM or UM

Information Element	Value/Remark
CHOICE channel requirement - Power Control Algorithm	Uplink DPCH info Algorithm2

See TS 34.108 [3] and TS 34.109 [4] for details regarding generic call setup procedure and loopback test.

6.5.4.2 Procedure

- 1) Set the parameters of the CW generator or the interference signal generator as shown in table 6.5.4, 6.5.5 and table 6.5.6. For table 6.5.5, the frequency step size is 1 MHz.
- 2) Set the power level of UE according to the table 6.5.4, table 6.5.5, and table 6.5.6, or send the power control commands (1dB step size should be used.) to the UE until UE output power measured by Test System shall be kept at the specified power level with ± 1 dB tolerance.
- 3) Measure the BER of DCH received from the UE at the SS.
- 4) For table 6.5.5, record the frequencies for which BER exceed the test requirements.

6.5.5 Test requirements

For table 6.5.4, the measured BER, derived in step 2), shall not exceed 0.001. For table 6.5.5, the measured BER, derived in step 2) shall not exceed 0,001 except for the spurious response frequencies, recorded in step 3). The number of spurious response frequencies, recorded in step 3) shall not exceed 24 for frequency range 1, 2 and 3. The number of spurious response frequencies, recorded in step 3) shall not exceed 8 for frequency range 4 . For table 6.5.6, the measured BER, derived in step 2), shall not exceed 0.001.

Table 6.5.4: Test parameters for In-band blocking characteristics

Parameter	Unit	Level	
DPCH_Ec	dBm/3.84 MHz	<REFSENS>+3 dB	
\hat{I}_{or}	dBm/3.84 MHz	<REF \hat{I}_{or} > + 3 dB	
$I_{blocking}$ mean power (modulated)	dBm	-56	-44
F_{uw} offset		± 10 MHz	≤ -15 MHz & ≥ 15 MHz
F_{uw} (Band I operation)	MHz	$2102.4 \leq f \leq 2177.6$ (Note 2)	$2095 \leq f \leq 2185$
F_{uw} (Band II operation)	MHz	$1922.4 \leq f \leq 1997.6$ (Note 2)	$1915 \leq f \leq 2005$
F_{uw} (Band III operation)	MHz	$1797.4 \leq f \leq 1887.6$ (Note 2)	$1790 \leq f \leq 1895$
F_{uw} (Band IV operation)	MHz	$2102.4 \leq f \leq 2162.6$ (Note 2)	$2095 \leq f \leq 2170$
F_{uw} (Band V operation)	MHz	$861.4 \leq f \leq 901.6$ (Note 2)	$854 \leq f \leq 909$
F_{uw} (Band VI operation)	MHz	$867.4 \leq f \leq 892.6$ (Note 2 and 3)	$860 \leq f \leq 900$ (Note 3)
F_{uw} (Band VII operation)	MHz	$2612.4 \leq f \leq 2697.6$ (Note 2)	$2605 \leq f \leq 2705$
F_{uw} (Band VIII operation)	MHz	$917.4 \leq f \leq 967.6$ (Note 2)	$910 \leq f \leq 975$
F_{uw} (Band IX operation)	MHz	$1837.4 \leq f \leq 1887.4$ (Note 2)	$1829.9 \leq f \leq 1894.9$
F_{uw} (Band X operation)	MHz	$2102.4 \leq f \leq 2177.6$ (Note 2)	$2095 \leq f \leq 2185$
F_{uw} (Band XI operation)	MHz	$1468.4 \leq f \leq 1508.4$ (Note 2)	$1460.9 \leq f \leq 1515.9$
UE transmitted mean power	dBm	20 (for Power class 3) 18 (for Power class 4)	

Note 1: $I_{blocking}$ (modulated) consists of the common channels needed for tests as specified in Table E.4.1 and 16 dedicated data channels as specified in Table E.3.6.

Note 2: For each carrier frequency the requirement is valid for two frequencies, the carrier frequency +/- 10 MHz.

Note 3: For Band VI, the unwanted interfering signal does not fall inside the UE receive band, but within the first 15 MHz below or above the UE receive band.

Table 6.5.5: Test parameters for Out of band blocking characteristics

Parameter	Unit	Frequency range 1	Frequency range 2	Frequency range 3	Frequency range 4
DPCH_Ec	dBm/3.84 MHz	<REFSENS>+3 dB	<REFSENS>+3 dB	<REFSENS>+3 dB	<REFSENS> +3 dB
\hat{I}_{or}	dBm/3.84 MHz	<REF \hat{I}_{or} > + 3 dB	<REF \hat{I}_{or} > + 3 dB	<REF \hat{I}_{or} > + 3 dB	<REF \hat{I}_{or} > + 3 dB
$I_{blocking}$ (CW)	dBm	-44	-30	-15	-15
F_{uw} (Band I operation)	MHz	2050<f <2095 2185<f <2230	2025 <f ≤2050 2230 ≤f <2255	1 < f ≤2025 2255≤f<12750	-
F_{uw} (Band II operation)	MHz	1870<f <1915 2005<f <2050	1845 <f ≤1870 2050 ≤f <2075	1 < f ≤1845 2075≤f<12750	1850 ≤ f ≤ 1910
F_{uw} (Band III operation)	MHz	1745 <f <1790 1895<f <1940	1720 <f ≤ 1745 1940≤f < 1965	1 < f ≤1720 1965≤f<12750	-
F_{uw} (Band IV operation)	MHz	2050< f <2095 2170< f <2215	2025< f ≤2050 2215≤ f < 2240	1 < f ≤2025 2240≤f<12750	-
F_{uw} (Band V operation)	MHz	809< f <854 909< f <954	784< f ≤809 954≤ f < 979	1 < f ≤784 979≤f<12750	824 ≤ f ≤ 849
F_{uw} (Band VI operation)	MHz	815 < f < 860 900 < f < 945	790 < f ≤ 815 945 ≤ f < 970	1 < f ≤ 790 970 ≤ f < 12750	-
F_{uw} (Band VII operation)	MHz	2570 < f < 2605 2705 < f < 2750	na 2750 ≤ f < 2775	1 < f ≤ 2570 2775 ≤ f < 12750	-
F_{uw} (Band VIII operation)	MHz	865 < f < 910 975 < f < 1020	840 < f ≤ 865 1020 ≤ f < 1045	1 < f ≤ 840 1045 ≤ f < 12750	-
F_{uw} (Band IX operation)	MHz	1785 < f < 1830 1895 < f < 1940	1760 < f ≤ 1785 1940 ≤ f < 1965	1 < f ≤ 1760 1965 ≤ f < 12750	-
F_{uw} (Band X operation)	MHz	2050 < f < 2095 2185 < f < 2230	2025 < f ≤ 2050 2230 ≤ f < 2255	1 < f ≤ 2025 2255 ≤ f < 12750	-
F_{uw} (Band XI operation)	MHz	1416 < f < 1461 1516 < f < 1561	1391 < f ≤ 1416 1561 ≤ f < 1586	1 < f ≤ 1391 1586 ≤ f < 12750	-
UE transmitted mean power	dBm		20 (for Power class 3) 18 (for Power class 4)		
Band I operation		For 2095≤f ≤2185 MHz, the appropriate in-band blocking or adjacent channel selectivity in clause 6.5.2 and clause 6.4.2 shall be applied.			
Band II operation		For 1915≤f ≤2005 MHz, the appropriate in-band blocking or adjacent channel selectivity in clause 6.5.2 and clause 6.4.2 shall be applied			
Band III operation		For 1790≤f ≤1895 MHz, the appropriate in-band blocking or adjacent channel selectivity in clause 6.5.2 and clause 6.4.2 shall be applied.			
Band IV operation		For 2095≤f ≤2170 MHz, the appropriate in-band blocking or adjacent channel selectivity in clause 6.5.2 and clause 6.4.2 shall be applied.			
Band VI operation		For 860<f<875 MHz and 885<f<900 MHz, the appropriate in-band blocking or adjacent channel selectivity in subclause 6.5.2 and subclause 6.4.2 shall be applied			
Band VII operation		For 2605 ≤ f ≤ 2705 MHz, the appropriate in-band blocking or adjacent channel selectivity in subclause 6.5.2 and subclause 6.4.2 shall be applied.			
Band VIII operation		For 910 ≤ f ≤ 975 MHz, the appropriate in-band blocking or adjacent channel selectivity in subclause 6.5.2 and subclause 6.4.2 shall be applied.			
Band IX operation		For 1830≤f ≤1895 MHz, the appropriate in-band blocking or adjacent channel selectivity in clause 6.5.2 and clause 6.4.2 shall be applied.			
Band X operation		For 2095 ≤ f ≤ 2185 MHz, the appropriate in-band blocking or adjacent channel selectivity in clause 6.5.2 and clause 6.4.2 shall be applied.			
Band XI operation		For 1461 ≤ f ≤ 1516 MHz, the appropriate in-band blocking or adjacent channel selectivity in clause 6.5.2 and clause 6.4.2 shall be applied.			

Table 6.5.6: Test parameters for narrow band blocking

Parameter	Unit	Band II, IV, V, X	Band III, VIII
DPCH_Ec	dBm/3.84 MHz	<REFSENS> + 10 dB	<REFSENS> + 10 dB
I _{or}	dBm/3.84 MHz	<REFI _{or} > + 10 dB	<REFI _{or} > + 10 dB
I _{blocking} (GMSK)	dBm	-57	-56
F _{uw} (offset)	MHz	2.7	2.8
UE transmitted mean power	dBm	20 (for Power class 3) 18 (for Power class 4)	

NOTE: If the above Test Requirement differs from the Minimum Requirement then the Test Tolerance applied for this test is non-zero. The Test Tolerance for this test is defined in clause F.2 and the explanation of how the Minimum Requirement has been relaxed by the Test Tolerance is given in clause F.4.

6.6 Spurious Response

6.6.1 Definition and applicability

Spurious response is a measure of the receiver's ability to receive a wanted signal on its assigned channel frequency without exceeding a given degradation due to the presence of an unwanted CW interfering signal at any other frequency at which a response is obtained i.e. for which the out of band blocking limit is not met.

The requirements and this test apply to all types of UTRA for the FDD UE.

6.6.2 Minimum Requirements

The BER shall not exceed 0,001 for the parameters specified in table 6.6.1.

The normative reference for this requirement is TS 25.101 [1] clause 7.7.1.

Table 6.6.1: Test parameters for Spurious Response

Parameter	Level	Unit
DPCH_Ec	<REFSENS> +3 dB	dBm / 3,84MHz
I _{or}	<REFI _{or} > +3 dB	dBm / 3,84MHz
I _{blocking} (CW)	-44	dBm
F _{uw}	Spurious response frequencies	MHz
UE transmitted mean power	20 (for Power class 3) 18 (for Power class 4)	dBm

6.6.3 Test purpose

To verify that the UE BER does not exceed 0,001 for the parameters specified in table 6.6.1.

The lack of the spurious response ability decreases the coverage area when other unwanted interfering signal exists at any other frequency.

6.6.4 Method of test

6.6.4.1 Initial conditions

Test environment: normal; see clauses G.2.1 and G.2.2.

Frequency to be tested: the same frequency as chosen in clause 6.5.4.1 for Blocking characteristics out-of-band case.

- 1) Connect the SS to the UE antenna connector as shown in figure A.6.
- 2) RF parameters are set up according to table 6.6.2.
- 3) A call is set up according to the Generic call setup procedure specified in TS 34.108 [3] sub clause 7.3.2, with the following exception for information elements in RADIO BEARER SETUP message. With this exception, the Power Control Algorithm for the Uplink is set to algorithm 2.

- 4) Enter the UE into loopback test mode and start the loopback test.

Table 6.6.1A Contents of RADIO BEARER SETUP message: AM or UM

Information Element	Value/Remark
CHOICE channel requirement - Power Control Algorithm	Uplink DPCH info Algorithm2

See TS 34.108 [3] and TS 34.109 [4] for details regarding generic call setup procedure and loopback test.

6.6.4.2 Procedure

- 1) Set the parameter of the CW generator as shown in table 6.6.2. The spurious response frequencies are determined in step 3) of clause 6.5.4.2.
- 2) Set the power level of UE according to the table 6.6.2 or send the power control commands (1dB step size should be used.) to the UE until UE output power measured by Test System shall be kept at the specified power level with ± 1 dB tolerance.
- 3) Measure the BER of DCH received from the UE at the SS.

6.6.5 Test requirements

The measured BER, derived in step 2), shall not exceed 0,001.

Table 6.6.2: Test parameters for Spurious Response

Parameter	Level	Unit
DPCH_Ec	<REFSENS> +3 dB	dBm / 3,84MHz
I_{or}	<REF I_{or} > +3 dB	dBm / 3,84MHz
$I_{blocking}(CW)$	-44	dBm
F_{uw}	Spurious response frequencies	MHz
UE transmitted mean power	20 (for Power class 3) 18 (for Power class 4)	dBm

NOTE: If the above Test Requirement differs from the Minimum Requirement then the Test Tolerance applied for this test is non-zero. The Test Tolerance for this test is defined in clause F.2 and the explanation of how the Minimum Requirement has been relaxed by the Test Tolerance is given in clause F.4.

6.7 Intermodulation Characteristics

6.7.1 Definition and applicability

Third and higher order mixing of the two interfering RF signals can produce an interfering signal in the band of the desired channel. Intermodulation response rejection is a measure of the capability of the receiver to receive a wanted signal on its assigned channel frequency in the presence of two or more interfering signals which have a specific frequency relationship to the wanted signal.

The requirements and this test apply to all types of UTRA for the FDD UE. The test parameters in tables 6.7.2 and 6.7.4 applies to the FDD UE supporting Band II, Band III, Band IV, Band V or Band VIII.

6.7.2 Minimum Requirements

The BER shall not exceed 0,001 for the parameters specified in table 6.7.1 and in table 6.7.2.

The normative reference for this requirement is TS 25.101 [1] clause 7.8.1 and clause 7.8.2.

NOTE: I_{ouw2} (modulated) consists of the common channels needed for tests as specified in table E.4.1 and 16 dedicated data channels as specified in table E.3.6.

Table 6.7.1: Test parameters for Intermodulation Characteristics

Parameter	Level	Unit
DPCH_Ec	<REFSENS> +3 dB	dBm / 3,84 MHz
\hat{I}_{or}	<REF \hat{I}_{or} > +3 dB	dBm / 3,84 MHz
I_{ouw1} (CW)	-46	dBm
I_{ouw2} mean power (modulated)	-46	dBm
F_{uw1} (offset)	10 -10	MHz
F_{uw2} (offset)	20 -20	MHz
UE transmitted mean power	20 (for Power class 3) 18 (for Power class 4)	dBm

Table 6.7.2: Test parameters for narrow band intermodulation characteristics

Parameter	Unit	Band II, IV, V, X	Band III, VIII
DPCH_Ec	dBm/3.84 MHz	<REFSENS>+ 10 dB	<REFSENS>+ 10 dB
\hat{I}_{or}	dBm/3.84 MHz	<REF \hat{I}_{or} > + 10 dB	[<REF \hat{I}_{or} > + 10 dB
I_{ouw1} (CW)	dBm	-44	-43
I_{ouw2} (GMSK)	dBm	-44	-43
F_{uw1} (offset)	MHz	3.5 -3.5	3.6 -3.6
F_{uw2} (offset)	MHz	5.9 -5.9	6.0 -6.0
UE transmitted mean power	dBm	20 (for Power class 3) 18 (for Power class 4)	

NOTE: I_{ouw2} (GMSK) is an interfering signal as defined in TS 45.004. It is a continuous GMSK modulated carrier following the structure of the GSM signals, but with all modulating bits (including the midamble period) derived directly from a random or any pseudo random data stream.

6.7.3 Test purpose

To verify that the UE BER does not exceed 0,001 for the parameters specified in table 6.7.1 and in table 6.7.2.

The lack of the intermodulation response rejection ability decreases the coverage area when two or more interfering signals, which have a specific frequency relationship to the wanted signal, exist.

6.7.4 Method of test

6.7.4.1 Initial conditions

Test environment: normal; see clauses G.2.1 and G.2.2.

Frequencies to be tested: mid range; see clause G.2.4.

- 1) Connect the SS to the UE antenna connector as shown in figure A.7.
- 2) RF parameters are set up according to table 6.7.3 and table 6.7.4.
- 3) A call is set up according to the Generic call setup procedure specified in TS 34.108 [3] sub clause 7.3.2, with the following exception for information elements in RADIO BEARER SETUP message. With this exception, the Power Control Algorithm for the Uplink is set to algorithm 2.
- 4) Enter the UE into loopback test mode and start the loopback test.

Table 6.7.2A Contents of RADIO BEARER SETUP message: AM or UM

Information Element	Value/Remark
CHOICE channel requirement - Power Control Algorithm	Uplink DPCH info Algorithm2

See TS 34.108 [3] and TS 34.109 [4] for details regarding generic call setup procedure and loopback test.

6.7.4.2 Procedure

- 1) Set the parameters of the CW generator and interference signal generator as shown in table 6.7.3 and in table 6.7.4.
- 2) Set the power level of UE according to the tables 6.7.3, and table 6.7.4 or send the power control commands (1dB step size should be used.) to the UE until UE output power measured by Test System shall be kept at the specified power level with ± 1 dB tolerance.
- 3) Measure the BER of DCH received from the UE at the SS.

6.7.5 Test requirements

The measured BER, derived in step 1), shall not exceed 0,001.

Table 6.7.3: Test parameters for Intermodulation Characteristics

Parameter	Level		Unit
DPCH_Ec	<REFSENS> +3 dB		dBm / 3.84 MHz
\hat{I}_{or}	<REF \hat{I}_{or} > +3 dB		dBm / 3.84 MHz
I_{ouw1} (CW)	-46		dBm
I_{ouw2} mean power (modulated)	-46		dBm
F_{uw1} (offset)	10	-10	MHz
F_{uw2} (offset)	20	-20	MHz
UE transmitted mean power	20 (for Power class 3) 18 (for Power class 4)		dBm

Table 6.7.4: Test parameters for narrow band intermodulation characteristics

Parameter	Unit	Band II, IV, V, X		Band III, VIII	
DPCH_Ec	DdBm/3.84 MHz	<REFSENS>+ 10 dB		<REFSENS>+ 10 dB	
\hat{I}_{or}	DdBm/3.84 MHz	<REF \hat{I}_{or} > + 10 dB		[<REF \hat{I}_{or} > + 10 dB	
I_{ouw1} (CW)	dBm	-44		-43	
I_{ouw2} (GMSK)	dBm	-44		-43	
F_{uw1} (offset)	MHz	3.5	-3.5	3.6	-3.6
F_{uw2} (offset)	MHz	5.9	-5.9	6.0	-6.0
UE transmitted mean power	dBm	20 (for Power class 3) 18 (for Power class 4)			

NOTE: If the above Test Requirement differs from the Minimum Requirement then the Test Tolerance applied for this test is non-zero. The Test Tolerance for this test is defined in clause F.2 and the explanation of how the Minimum Requirement has been relaxed by the Test Tolerance is given in clause F.4.

6.8 Spurious Emissions

6.8.1 Definition and applicability

The spurious emissions power is the power of emissions generated or amplified in a receiver that appear at the UE antenna connector.

The requirements and this test apply to all types of UTRA for the FDD UE.

6.8.2 Minimum Requirements

The power of any narrow band CW spurious emission shall not exceed the maximum level specified in table 6.8.1 and table 6.8.2.

Table 6.8.1: General receiver spurious emission requirements

Frequency Band	Measurement Bandwidth	Maximum level	Note
$30 \text{ MHz} \leq f < 1 \text{ GHz}$	100 kHz	-57 dBm	
$1 \text{ GHz} \leq f \leq 12,75 \text{ GHz}$	1 MHz	-47 dBm	

Table 6.8.2: Additional receiver spurious emission requirements

Operating band	Frequency Band	Measurement Bandwidth	Maximum level	Note
I	1475.9 MHz ≤ f ≤ 1500.9 MHz	3.84 MHz	-60 dBm	
	1844.9 MHz ≤ f ≤ 1879.9 MHz	3.84 MHz	-60 dBm	
	1 920 MHz ≤ f ≤ 1 980 MHz	3,84 MHz	-60 dBm	UE transmit band in URA_PCH, Cell_PCH and idle state
	2 110 MHz ≤ f ≤ 2 170 MHz	3,84 MHz	-60 dBm	UE receive band
II	1850 MHz ≤ f ≤ 1910 MHz	3.84 MHz	-60 dBm	UE transmit band in URA_PCH, Cell_PCH and idle state
	1930 MHz ≤ f ≤ 1990 MHz	3.84 MHz	-60 dBm	UE receive band
III	1710 MHz ≤ f ≤ 1785 MHz	3.84 MHz	-60 dBm	UE transmit band in URA_PCH, Cell_PCH and idle state
	1805 MHz ≤ f ≤ 1880 MHz	3.84 MHz	-60 dBm	UE receive band
IV	869 MHz ≤ f < 894 MHz	3.84 MHz	-60 dBm	
	1710 MHz ≤ f < 1755 MHz	3.84 MHz	-60 dBm	UE transmit band in URA_PCH, Cell_PCH and idle state
	1930 MHz ≤ f ≤ 1990 MHz	3.84 MHz	-60 dBm	
	2110 MHz ≤ f ≤ 2170 MHz	3.84 MHz	-60 dBm	UE receive band
V	824 MHz ≤ f ≤ 849 MHz	3.84 MHz	-60 dBm	UE transmit band in URA_PCH, Cell_PCH and idle state
	869 MHz ≤ f < 894 MHz	3.84 MHz	-60 dBm	UE receive band
VI	815 MHz ≤ f ≤ 850 MHz	3.84 MHz	-60 dBm	UE in URA_PCH, Cell_PCH and idle state
	860 MHz ≤ f ≤ 895 MHz	3.84 MHz	-60 dBm	UE in URA_PCH, Cell_PCH and idle state
	1475.9 MHz ≤ f ≤ 1500.9 MHz	3.84 MHz	-60 dBm	
	1844.9 MHz ≤ f ≤ 1879.9 MHz	3.84 MHz	-60 dBm	
	2110 MHz ≤ f ≤ 2170 MHz	3.84 MHz	-60 dBm	
VII	921 MHz ≤ f < 925 MHz	100 kHz	-60 dBm (see note)	
	925 MHz ≤ f ≤ 935 MHz	100 kHz	-67 dBm (see note)	
		-3.84 MHz	-60 dBm	
	935 MHz < f ≤ 960 MHz	100 kHz	-79 dBm (see note)	
	1805 MHz ≤ f ≤ 1880 MHz	100 kHz	-71 dBm (see note)	
	2110 MHz ≤ f ≤ 2170 MHz	3.84 MHz	-60 dBm	
	2500 MHz ≤ f ≤ 2570 MHz	3.84 MHz	-60 dBm	UE transmit band in URA_PCH, Cell_PCH and idle state
VIII	2620 MHz ≤ f ≤ 2690 MHz	3.84 MHz	-60 dBm	UE receive band
	880 MHz ≤ f ≤ 915 MHz	3.84 MHz	-60 dBm	
	921 MHz ≤ f < 925 MHz	100 kHz	-60 dBm (see note)	
	925 MHz ≤ f ≤ 935 MHz	100 kHz	-67 dBm (see note)	
		3.84 MHz	-60 dBm	
	935 MHz < f ≤ 960 MHz	100 kHz	-79 dBm (see note)	
	1805 MHz < f ≤ 1880 MHz	3.84 MHz	-60 dBm	
	2110 MHz ≤ f ≤ 2170 MHz	3.84 MHz	-60 dBm	
2620 MHz ≤ f ≤ 2690 MHz	3.84 MHz	-60 dBm		
IX	860 MHz ≤ f ≤ 895 MHz	3.84 MHz	-60 dBm	
	1475.9 MHz ≤ f ≤ 1500.9 MHz	3.84 MHz	-60 dBm	
	1749.9 MHz ≤ f ≤ 1784.9 MHz	3.84 MHz	-60 dBm	UE transmit band in URA_PCH, Cell_PCH and idle state

	1844.9 MHz ≤ f ≤ 1879.9 MHz	3.84 MHz	-60 dBm	UE receive band
	2110 MHz ≤ f ≤ 2170 MHz	3.84 MHz	-60 dBm	
X	869 MHz ≤ f < 894 MHz	3.84 MHz	- 60 dBm	
	1710 MHz ≤ f < 1770 MHz	3.84 MHz	- 60 dBm	UE transmit band in URA_PCH, Cell_PCH and idle state
	1930 MHz ≤ f ≤ 1990 MHz	3.84 MHz	- 60 dBm	
	2110 MHz ≤ f ≤ 2170 MHz	3.84 MHz	-60 dBm	UE receive band
XI	860 MHz ≤ f ≤ 895 MHz	3.84 MHz	-60 dBm	
	1427.9 MHz ≤ f ≤ 1452.9 MHz	3.84 MHz	-60 dBm	UE transmit band in URA_PCH, Cell_PCH and idle state
	1475.9 MHz ≤ f ≤ 1500.9 MHz	3.84 MHz	-60 dBm	UE receive band
	1844.9 MHz ≤ f ≤ 1879.9 MHz	3.84 MHz	-60 dBm	
	2110 MHz ≤ f ≤ 2170 MHz	3.84 MHz	-60 dBm	
Note:	The measurements are made on frequencies which are integer multiples of 200 kHz. As exceptions, up to five measurements with a level up to the applicable requirements defined in Table 7.10 are permitted for each UARFCN used in the measurement			

The reference for this requirement is TS 25.101 [1] clause 7.9.1.

6.8.3 Test purpose

To verify that the UE spurious emission meets the specifications described in clause 6.8.2.

Excess spurious emissions increase the interference to other systems.

6.8.4 Method of test

6.8.4.1 Initial conditions

Test environment: normal; see clauses G.2.1 and G.2.2.

Frequencies to be tested: low range, mid range, high range; see clause G.2.4.

- 1) Connect a spectrum analyzer (or other suitable test equipment) to the UE antenna connector as shown in figure A.8.
- 2) RF parameters are setup according to table E.3.2.2. Settings for the serving cell are defined in table 6.8.2A.
- 3) A call is set up according to the setup procedure specified in TS34.108 [3] sub clause 7.3.5, with the following exceptions for information elements in System Information Block type3.

SIB 3 Information Element	Value/Remark
- Cell selection and re-selection info	FDD
- CHOICE mode	0 dB
- Sintrasearch	0 dB
- Sintersearch	This parameter is not present
- RAT List	Power level where Pcompensation=0
- Maximum allowed UL TX power	

The exceptions for SIB1 are defined in TS 34.108 [3] clause 7.3.5.2.

NOTE: The setup procedure (3) sets the UE into the CELL_FACH state. With this state and the SS level (2) it is ensured that UE continuously monitors the S-CCPCH and no cell reselections are performed [see 3GPP TS 25.304, clauses 5.2.3.and 5.2.6]. The UE will not be transmitting, and therefore will not interfere with the measurement.

Table 6.8.2A: Settings for the serving cell during the measurement of Rx Spurious Emissions

Parameter	Unit	Cell 1
Cell type		Serving cell
UTRA RF Channel Number		As defined in clause 6.8.4.1
Qqualmin	dB	-24
Qrxlevmin	dBm	-115
UE_TXPWR_MAX_RACH	dBm	+21
CPICH Ec (see notes 1 and 2)	dBm/3.84 MHz	As defined in table E.3.2.2
NOTE 1: The power level is specified in terms of CPICH_Ec instead of CPICH_RSCP as RSCP is a receiver measurement and only CPICH_Ec can be directly controlled by the SS.		
NOTE 2: The cell fulfils TS 25.304, 5.2.3.1.2.		

6.8.4.2 Procedure

- 1) Sweep the spectrum analyzer (or equivalent equipment) over a frequency range and measure the average power of spurious emission.

6.8.5 Test requirements

It shall be verified that the RRC connection release at the end of the procedure described in 34.108 [3] clause 7.3.5.3 shall be completed successfully indicating that the UE has stayed in CELL_FACH state during the measurement of the spurious emissions.

The measured spurious emissions, derived in step 1), shall not exceed the maximum level specified in table 6.8.3 and table 6.8.4.

Table 6.8.3: General receiver spurious emission requirements

Frequency Band	Measurement Bandwidth	Maximum level	Note
$30 \text{ MHz} \leq f < 1 \text{ GHz}$	100 kHz	-57 dBm	
$1 \text{ GHz} \leq f \leq 12,75 \text{ GHz}$	1 MHz	-47 dBm	

Table 6.8.4: Additional receiver spurious emission requirements

Operating Band	Frequency Band	Measurement Bandwidth	Maximum level	Note
I	$1475.9 \text{ MHz} \leq f \leq 1500.9 \text{ MHz}$	3.84 MHz	-60 dBm	
	$1844.9 \text{ MHz} \leq f \leq 1879.9 \text{ MHz}$	3.84 MHz	-60 dBm	
	$1\ 920 \text{ MHz} \leq f \leq 1\ 980 \text{ MHz}$	3,84 MHz	-60 dBm	UE transmit band
	$2\ 110 \text{ MHz} \leq f \leq 2\ 170 \text{ MHz}$	3,84 MHz	-60 dBm	UE receive band
II	$1850 \text{ MHz} \leq f \leq 1910 \text{ MHz}$	3.84 MHz	-60 dBm	UE transmit band
	$1930 \text{ MHz} \leq f \leq 1990 \text{ MHz}$	3.84 MHz	-60 dBm	UE receive band
III	$1710 \text{ MHz} \leq f \leq 1785 \text{ MHz}$	3.84 MHz	-60 dBm	UE transmit band
	$1805 \text{ MHz} \leq f \leq 1880 \text{ MHz}$	3.84 MHz	-60 dBm	UE receive band
IV	$869 \text{ MHz} \leq f < 894 \text{ MHz}$	3.84 MHz	-60 dBm	
	$1710 \text{ MHz} \leq f < 1755 \text{ MHz}$	3.84 MHz	-60 dBm	UE transmit band
	$1930 \text{ MHz} \leq f \leq 1990 \text{ MHz}$	3.84 MHz	-60 dBm	
	$2110 \text{ MHz} \leq f \leq 2155 \text{ MHz}$	3.84 MHz	-60 dBm	UE receive band (see note 1)
	$2110 \text{ MHz} \leq f \leq 2170 \text{ MHz}$	3.8.4 MHz	-60 dBm	UE receive band (see note 2)
V	$824 \text{ MHz} \leq f \leq 849 \text{ MHz}$	3.84 MHz	-60 dBm	UE transmit band
	$869 \text{ MHz} \leq f < 894 \text{ MHz}$	3.84 MHz	-60 dBm	UE receive band
VI	$815 \text{ MHz} \leq f \leq 850 \text{ MHz}$	3.84 MHz	-60 dBm	
	$860 \text{ MHz} \leq f \leq 895 \text{ MHz}$	3.84 MHz	-60 dBm	
	$1475.9 \text{ MHz} \leq f \leq 1500.9 \text{ MHz}$	3.84 MHz	-60 dBm	
	$1844.9 \text{ MHz} \leq f \leq 1879.9 \text{ MHz}$	3.84 MHz	-60 dBm	
	$2110 \text{ MHz} \leq f \leq 2170 \text{ MHz}$	3.84 MHz	-60 dBm	
VII	$921 \text{ MHz} \leq f < 925 \text{ MHz}$	100 kHz	-60 dBm (see note)	
	$925 \text{ MHz} \leq f \leq 935 \text{ MHz}$	100 kHz -3.84 MHz	-67 dBm (see note) -60 dBm	
	$935 \text{ MHz} < f \leq 960 \text{ MHz}$	100 kHz	-79 dBm (see note)	
	$1805 \text{ MHz} \leq f \leq 1880 \text{ MHz}$	100 kHz	-71 dBm (see note)	
	$2110 \text{ MHz} \leq f \leq 2170 \text{ MHz}$	3.84 MHz	-60 dBm	
	$2500 \text{ MHz} \leq f \leq 2570 \text{ MHz}$	3.84 MHz	-60 dBm	UE transmit band
	$2620 \text{ MHz} \leq f \leq 2690 \text{ MHz}$	3.84 MHz	-60 dBm	UE receive band
VIII	$880 \text{ MHz} \leq f \leq 915 \text{ MHz}$	3.84 MHz	-60 dBm	
	$921 \text{ MHz} \leq f < 925 \text{ MHz}$	100 kHz	-60 dBm (see note)	
	$925 \text{ MHz} \leq f \leq 935 \text{ MHz}$	100 kHz 3.84 MHz	-67 dBm (see note) -60 dBm	
	$935 \text{ MHz} < f \leq 960 \text{ MHz}$	100 kHz	-79 dBm (see note)	

	1805 MHz < f ≤ 1880 MHz	3.84 MHz	-60 dBm	
	2110 MHz ≤ f ≤ 2170 MHz	3.84 MHz	-60 dBm	
	2620 MHz ≤ f ≤ 2690 MHz	3.84 MHz	-60 dBm	
IX	860 MHz ≤ f ≤ 895 MHz	3.84 MHz	-60 dBm	
	1475.9 MHz ≤ f ≤ 1500.9 MHz	3.84 MHz	-60 dBm	
	1749.9 MHz ≤ f ≤ 1784.9 MHz	3.84 MHz	-60 dBm	UE transmit band
	1844.9 MHz ≤ f ≤ 1879.9 MHz	3.84 MHz	-60 dBm	UE receive band
	2110 MHz ≤ f ≤ 2170 MHz	3.84 MHz	-60 dBm	
X	869 MHz ≤ f < 894 MHz	3.84 MHz	-60 dBm	
	1710 MHz ≤ f < 1770 MHz	3.84 MHz	-60 dBm	UE transmit band
	1930 MHz ≤ f ≤ 1990 MHz	3.84 MHz	-60 dBm	
	2110 MHz ≤ f ≤ 2170 MHz	3.84 MHz	-60 dBm	UE transmit band
XI	860 MHz ≤ f ≤ 895 MHz	3.84 MHz	-60 dBm	
	1427.9 MHz ≤ f ≤ 1452.9 MHz	3.84 MHz	-60 dBm	UE transmit band
	1475.9 MHz ≤ f ≤ 1500.9 MHz	3.84 MHz	-60 dBm	UE receive band
	1844.9 MHz ≤ f ≤ 1879.9 MHz	3.84 MHz	-60 dBm	
	2110 MHz ≤ f ≤ 2170 MHz	3.84 MHz	-60 dBm	
Note:	The measurements are made on frequencies which are integer multiples of 200 kHz. As exceptions, up to five measurements with a level up to the applicable requirements defined in Table 7.10 are permitted for each UARFCN used in the measurement.			
Note 1:	For UEs that conform to Release 6 and support Band IV shall support the defined frequency bandwidth.			
Note 2:	For UEs that conform to Release 7 and later releases and support Band IV shall support the defined frequency bandwidth.			

NOTE 1: If the above Test Requirement differs from the Minimum Requirement then the Test Tolerance applied for this test is non-zero. The Test Tolerance for this test is defined in clause F.2 and the explanation of how the Minimum Requirement has been relaxed by the Test Tolerance is given in clause F.4.

NOTE 2: The Test Requirements are measured in the CELL_FACH state instead of in the UE states defined in the Minimum Requirement because the CELL_FACH state ensures that the UE receiver is continuously on and the UE transmitter is off whilst the spectrum analyser searches for spurious emissions. The UE states defined in the Minimum Requirement allow the UE receiver to be in discontinuous reception, and using those UE states during the measurement would have resulted in a complicated and significantly lengthened test procedure since the UE receiver would be allowed to be switched off part of the time.

7 Performance requirements

7.1 General

The performance requirements for the UE in this clause are specified for the measurement channels specified in annex C and table 7.1.1, the propagation conditions specified in clause 7.1.2 and the Down link Physical channels specified in annex D. Unless stated otherwise, DL power control is OFF. Unless otherwise stated the performance requirements are specified at the antenna connector of the UE. For UE(s) with more than one receive antenna connector the fading of the signals and the AWGN signals applied to each receiver antenna connector shall be uncorrelated. The levels of the test signal applied to each of the antenna connectors shall be as defined in the respective sections below.

When DCCH has been configured on downlink DCH then DCCH Data shall be continuously transmitted on downlink DCH during the measurement period. When there is no signalling to transmit on downlink DCCH then dummy DCCH transmission as described in Annex C.9 shall be used.

The method for Block Error Ratio (BLER) measurement is specified in Annex C.6. See 3GPP TS 34.109 [4] for details regarding the UE test loop.

Table 7.1.1: Bit / Symbol rate for Test Channel

Type of User Information	User bit rate	DL DPCH symbol rate	DL DPCH bit rate	TTI (ms)
12,2 kbps reference measurement channel	12,2 kbps	30 ksps	60 kbps	20
64 kbps reference measurement channel	64 kbps	120 ksps	240 kbps	20
144kbps reference measurement channel	144 kbps	240 ksps	480 kbps	20
384 kbps reference measurement channel	384 kbps	480 ksps	960 kbps	10

The common RF test conditions of Performance requirement are defined in clause E.3.3, and each test conditions in this clause (clause 7) should refer clause E.3.3. Individual test conditions are defined in the paragraph of each test.

All Block Error ratio (BLER) measurements in clause 7 shall be performed according to the general rules for statistical testing in Annex F.6

7.1.1 Measurement Configurations

It is assumed that fields inside DPCH have the same energy per PN chip. Also, if the power of S-CCPCH is not specified in the test parameter table, it should be set to zero. The power of OCNS should be adjusted that the power ratios (E_c/I_{or}) of all specified downlink channels add up to one.

Unless otherwise stated, the UE output power for the tests shall be greater than -10 dBm.

Note 1: If tests are performed with maximum UE output power it is known that this may cause a good UE to fail at least for tests in sections 7.7 and 7.10.

7.1.2 Definition of Additive White Gaussian Noise (AWGN) Interferer

See clause D.1.1.

7.2 Demodulation in Static Propagation conditions

7.2.1 Demodulation of Dedicated Channel (DCH)

7.2.1.1 Definition and applicability

The receive characteristic of the Dedicated Channel (DCH) in the static environment is determined by the Block Error Ratio (BLER). BLER is specified for each individual data rate of the DCH. DCH is mapped into the Dedicated Physical Channel (DPCH).

The UE shall be tested only according to the data rate, supported. The data-rate-corresponding requirements shall apply to the UE.

7.2.1.2 Minimum requirements

For the parameters specified in table 7.2.1.1 the average downlink $\frac{DPCH - E_c}{I_{or}}$ power ratio shall be below the specified value for the BLER shown in table 7.2.1.2. These requirements are applicable for TFCS size 16.

Table 7.2.1.1: DCH parameters in static propagation conditions

Parameter	Test 1	Test 2	Test 3	Test 4	Unit
Phase reference		P-CPICH			
\hat{I}_{or}/I_{oc}		-1			dB
I_{oc}		-60			dBm / 3,84 MHz
Information Data Rate	12,2	64	144	384	kbps

Table 7.2.1.2: DCH requirements in static propagation conditions

Test Number	$\frac{DPCH - E_c}{I_{or}}$	BLER
1	-16,6 dB	10^{-2}
2	-13,1 dB	10^{-1}
	-12,8 dB	10^{-2}
3	-9,9 dB	10^{-1}
	-9,8 dB	10^{-2}
4	-5,6 dB	10^{-1}
	-5,5 dB	10^{-2}

The reference for this requirement is TS 25.101 [1] clause 8.2.3.1.

7.2.1.3 Test purpose

To verify the ability of the receiver to receive a predefined test signal, representing a static propagation channel for the wanted and for the co-channel signals from serving and adjacent cells, with a BLER not exceeding a specified value.

7.2.1.4 Method of test

7.2.1.4.1 Initial conditions

Test environment: normal; see clauses G.2.1 and G.2.2.

Frequencies to be tested: mid range; see clause G.2.4.

1. Connect the SS and an AWGN noise source to the UE antenna connector as shown in figure A.9.
2. Set up a call according to the Generic call setup procedure TS34.108 [3] sub clause 7.3.2.
3. Set the test parameters for test 1-4 as specified in table 7.2.1.3.

4. Enter the UE into loopback test mode and start the loopback test.

7.2.1.4.2 Procedures

1. Measure BLER of DCH.

7.2.1.5 Test requirements

For the parameters specified in table 7.2.1.3 the average downlink $\frac{DPCH_E_c}{I_{or}}$ power ratio shall be below the specified value for the BLER shown in table 7.2.1.4. These requirements are applicable for TFCS size 16.

NOTE: The test case is executed with TFCS size 4 according to the Reference Measurement Channels defined in Annex C.

Table 7.2.1.3: DCH parameters in static propagation conditions

Parameter	Test 1	Test 2	Test 3	Test 4	Unit
Phase reference		P-CPICH			
\hat{I}_{or}/I_{oc}		-0,7			dB
I_{oc}		-60			dBm / 3,84 MHz
Information Data Rate	12,2	64	144	384	kbps

Table 7.2.1.4: DCH requirements in static propagation conditions

Test Number	$\frac{DPCH_E_c}{I_{or}}$	BLER
1	-16,5 dB	10^{-2}
2	-13,0 dB	10^{-1}
	-12,7 dB	10^{-2}
3	-9,8 dB	10^{-1}
	-9,7 dB	10^{-2}
4	-5,5 dB	10^{-1}
	-5,4 dB	10^{-2}

NOTE: If the above Test Requirement differs from the Minimum Requirement then the Test Tolerance applied for this test is non-zero. The Test Tolerance for this test is defined in clause F.2 and the explanation of how the Minimum Requirement has been relaxed by the Test Tolerance is given in clause F.4.

7.3 Demodulation of DCH in Multi-path Fading Propagation conditions

7.3.1 Single Link Performance

7.3.1.1 Definition and applicability

The receive characteristics of the Dedicated Channel (DCH) in different multi-path fading environments are determined by the Block Error Ratio (BLER) values. BLER is measured for the each of the individual data rate specified for the DPCH. DCH is mapped into in Dedicated Physical Channel (DPCH).

The UE shall be tested only according to the data rate, supported. The data-rate-corresponding requirements shall apply to the UE.

7.3.1.2 Minimum requirements

For the parameters specified in tables 7.3.1.1, 7.3.1.3, 7.3.1.5, 7.3.1.7 and 7.3.1.9 the average downlink $\frac{DPCH_E_c}{I_{or}}$ power ratio shall be below the specified value for the BLER shown in tables 7.3.1.2, 7.3.1.4, 7.3.1.6, 7.3.1.8 and 7.3.1.10. These requirements are applicable for TFCS size 16.

Table 7.3.1.1: DCH parameters in multi-path fading propagation conditions (Case 1)

Parameter	Test 1	Test 2	Test 3	Test 4	Unit
Phase reference		P-CPICH			
\hat{I}_{or}/I_{oc}		9			dB
I_{oc}		-60			dBm / 3,84 MHz
Information Data Rate	12,2	64	144	384	kbps

Table 7.3.1.2: DCH requirements in multi-path fading propagation conditions (Case 1)

Test Number	$\frac{DPCH_E_c}{I_{or}}$	BLER
1	-15,0 dB	10^{-2}
2	-13,9 dB	10^{-1}
	-10,0 dB	10^{-2}
3	-10,6 dB	10^{-1}
	-6,8 dB	10^{-2}
4	-6,3 dB	10^{-1}
	-2,2 dB	10^{-2}

Table 7.3.1.3: DCH parameters in multi-path fading propagation conditions (Case 2)

Parameter	Test 5	Test 6	Test 7	Test 8	Unit
Phase reference		P-CPICH			
\hat{I}_{or}/I_{oc}	-3	-3	3	6	dB
I_{oc}		-60			dBm / 3,84 MHz
Information Data Rate	12,2	64	144	384	kbps

Table 7.3.1.4: DCH requirements in multi-path fading propagation conditions (Case 2)

Test Number	$\frac{DPCH_E_c}{I_{or}}$	BLER
5	-7,7 dB	10^{-2}
6	-6,4 dB	10^{-1}
	-2,7 dB	10^{-2}
7	-8,1 dB	10^{-1}
	-5,1 dB	10^{-2}
8	-5,5 dB	10^{-1}
	-3,2 dB	10^{-2}

Table 7.3.1.5: DCH parameters in multi-path fading propagation conditions (Case 3)

Parameter	Test 9	Test 10	Test 11	Test 12	Unit
Phase reference			P-CPICH		
\hat{I}_{or}/I_{oc}	-3	-3	3	6	dB
I_{oc}			-60		dBm / 3,84 MHz
Information Data Rate	12,2	64	144	384	kbps

Table 7.3.1.6: DCH requirements in multi-path fading propagation conditions (Case 3)

Test Number	$\frac{DPCH - E_c}{I_{or}}$	BLER
9	-11,8 dB	10^{-2}
10	-8,1 dB	10^{-1}
	-7,4 dB	10^{-2}
	-6,8 dB	10^{-3}
11	-9,0 dB	10^{-1}
	-8,5 dB	10^{-2}
	-8,0 dB	10^{-3}
12	-5,9 dB	10^{-1}
	-5,1 dB	10^{-2}
	-4,4 dB	10^{-3}

Table 7.3.1.7: DCH parameters in multi-path fading propagation conditions (Case 1) with S-CPICH

Parameter	Test 13	Test 14	Test 15	Test 16	Unit
Phase reference			S-CPICH		
\hat{I}_{or}/I_{oc}		9			dB
I_{oc}		-60			dBm / 3,84 MHz
Information Data Rate	12,2	64	144	384	kbps

Table 7.3.1.8: DCH requirements in multi-path fading propagation conditions (Case 1) with S-CPICH

Test Number	$\frac{DPCH - E_c}{I_{or}}$	BLER
13	-15,0 dB	10^{-2}
14	-13,9 dB	10^{-1}
	-10,0 dB	10^{-2}
15	-10,6 dB	10^{-1}
	-6,8 dB	10^{-2}
16	-6,3 dB	10^{-1}
	-2,2 dB	10^{-2}

Table 7.3.1.9: DCH parameters in multi-path fading propagation conditions (Case 6)

Parameter	Test 17	Test 18	Test 19	Test 20	Unit
Phase reference			P-CPICH		
\hat{I}_{or}/I_{oc}	-3	-3	3	6	dB
I_{oc}		-60			dBm / 3,84 MHz
Information Data Rate	12,2	64	144	384	kbps

Table 7.3.1.10: DCH requirements in multi-path fading propagation conditions (Case 6)

Test Number	$\frac{DPCH_E_c}{I_{or}}$	BLER
17	-8,8 dB	10^{-2}
18	-5,1 dB	10^{-1}
	-4,4 dB	10^{-2}
	-3,8 dB	10^{-3}
19	-6,0 dB	10^{-1}
	-5,5 dB	10^{-2}
	-5,0 dB	10^{-3}
20	-2,9 dB	10^{-1}
	-2,1 dB	10^{-2}
	-1,4 dB	10^{-3}

The reference for this requirement is TS 25.101 [1] clause 8.3.1.1.

7.3.1.3 Test purpose

To verify the ability of the receiver to receive a predefined test signal, representing a multi-path fading propagation channel for the wanted and for the co-channel signals from serving and adjacent cells, with a BLER not exceeding a specified value.

7.3.1.4 Method of test

7.3.1.4.1 Initial conditions

Test environment: normal; see clauses G.2.1 and G.2.2.

Frequencies to be tested: mid range; see clause G.2.4.

1. Connect the SS, multi-path fading simulator and an AWGN noise source to the UE antenna connector as shown in figure A.10.
2. Set up a call according to the Generic call setup procedure TS34.108 [3] sub clause 7.3.2.
3. Set the test parameters for test 1-20 as specified table 7.3.1.11, table 7.3.1.13, table 7.3.1.15, table 7.3.1.17 and table 7.3.1.19.
4. Enter the UE into loopback test mode and start the loopback test.
5. Setup fading simulators as fading condition case 1, case 2, case 3 and case 6, which are described in table D.2.2.1.

7.3.1.4.2 Procedures

1. Measure BLER of DCH.

7.3.1.5 Test requirements

For the parameters specified in tables 7.3.1.11, 7.3.1.13, 7.3.1.15, 7.3.1.17 and 7.3.1.19 the average downlink $\frac{DPCH_E_c}{I_{or}}$ power ratio shall be below the specified value for the BLER shown in tables 7.3.1.12, 7.3.1.14, 7.3.1.16,

7.3.1.18 and 7.3.1.20. These requirements are applicable for TFCS size 16.

NOTE: The test case is executed with TFCS size 4 according to the Reference Measurement Channels defined in Annex C.

Table 7.3.1.11: DCH parameters in multi-path fading propagation conditions (Case 1)

Parameter	Test 1	Test 2	Test 3	Test 4	Unit
Phase reference			P-CPICH		
\hat{I}_{or}/I_{oc}		9,6			dB
I_{oc}		-60			dBm / 3,84 MHz
Information Data Rate	12,2	64	144	384	kbps

Table 7.3.1.12: DCH requirements in multi-path fading propagation conditions (Case 1)

Test Number	$\frac{DPCH - E_c}{I_{or}}$	BLER
1	-14,9 dB	10^{-2}
2	-13,8 dB	10^{-1}
	-9,9 dB	10^{-2}
3	-10,5 dB	10^{-1}
	-6,7 dB	10^{-2}
4	-6,2 dB	10^{-1}
	-2,1 dB	10^{-2}

Table 7.3.1.13: DCH parameters in multi-path fading propagation conditions (Case 2)

Parameter	Test 5	Test 6	Test 7	Test 8	Unit
Phase reference			P-CPICH		
\hat{I}_{or}/I_{oc}	-2,4	-2,4	3,6	6,6	dB
I_{oc}		-60			dBm / 3,84 MHz
Information Data Rate	12,2	64	144	384	kbps

Table 7.3.1.14: DCH requirements in multi-path fading propagation conditions (Case 2)

Test Number	$\frac{DPCH - E_c}{I_{or}}$	BLER
5	-7,6 dB	10^{-2}
6	-6,3 dB	10^{-1}
	-2,6 dB	10^{-2}
7	-8,0 dB	10^{-1}
	-5,0 dB	10^{-2}
8	-5,4 dB	10^{-1}
	-3,1 dB	10^{-2}

Table 7.3.1.15: DCH parameters in multi-path fading propagation conditions (Case 3)

Parameter	Test 9	Test 10	Test 11	Test 12	Unit
Phase reference			P-CPICH		
\hat{I}_{or}/I_{oc}	-2,4	-2,4	3,6	6,6	dB
I_{oc}		-60			dBm / 3,84 MHz
Information Data Rate	12,2	64	144	384	kbps

Table 7.3.1.16: DCH requirements in multi-path fading propagation conditions (Case 3)

Test Number	$\frac{DPCH_E_c}{I_{or}}$	BLER
9	-11,7 dB	10^{-2}
10	-8,0 dB	10^{-1}
	-7,3 dB	10^{-2}
	-6,7 dB	10^{-3}
11	-8,9 dB	10^{-1}
	-8,4 dB	10^{-2}
	-7,9 dB	10^{-3}
12	-5,8 dB	10^{-1}
	-5,0 dB	10^{-2}
	-4,3 dB	10^{-3}

Table 7.3.1.17: DCH parameters in multi-path fading propagation conditions (Case 1) with S-CPICH

Parameter	Test 13	Test 14	Test 15	Test 16	Unit
Phase reference		S-CPICH			
\hat{I}_{or}/I_{oc}		9,6			dB
I_{oc}		-60			dBm / 3,84 MHz
Information Data Rate	12,2	64	144	384	kbps

Table 7.3.1.18: DCH requirements in multi-path fading propagation conditions (Case 1) with S-CPICH

Test Number	$\frac{DPCH_E_c}{I_{or}}$	BLER
13	-14,9 dB	10^{-2}
14	-13,8 dB	10^{-1}
	-9,9 dB	10^{-2}
15	-10,5 dB	10^{-1}
	-6,7 dB	10^{-2}
16	-6,2 dB	10^{-1}
	-2,1 dB	10^{-2}

Table 7.3.1.19: DCH parameters in multi-path fading propagation conditions (Case 6)

Parameter	Test 17	Test 18	Test 19	Test 20	Unit
Phase reference		P-CPICH			
\hat{I}_{or}/I_{oc}	-2,4	-2,4	3,6	6,6	dB
I_{oc}		-60			dBm / 3,84 MHz
Information Data Rate	12,2	64	144	384	kbps

Table 7.3.1.20: DCH requirements in multi-path fading propagation conditions (Case 6)

Test Number	$\frac{DPCH - E_c}{I_{or}}$	BLER
17	-8,7 dB	10^{-2}
18	-5,0 dB	10^{-1}
	-4,3 dB	10^{-2}
	-3,7 dB	10^{-3}
19	-5,9 dB	10^{-1}
	-5,4 dB	10^{-2}
	-4,9 dB	10^{-3}
20	-2,8 dB	10^{-1}
	-2,0 dB	10^{-2}
	-1,3 dB	10^{-3}

NOTE: If the above Test Requirement differs from the Minimum Requirement then the Test Tolerance applied for this test is non-zero. The Test Tolerance for this test is defined in clause F.2 and the explanation of how the Minimum Requirement has been relaxed by the Test Tolerance is given in clause F.4.

7.4 Demodulation of DCH in Moving Propagation conditions

7.4.1 Single Link Performance

7.4.1.1 Definition and applicability

The receive single link performance of the Dedicated Channel (DCH) in dynamic moving propagation conditions are determined by the Block Error Ratio (BLER) values. BLER is measured for the each of the individual data rate specified for the DPCH. DCH is mapped into Dedicated Physical Channel (DPCH).

The UE shall be tested only according to the data rate, supported. The data-rate-corresponding requirements shall apply to the UE.

7.4.1.2 Minimum requirements

For the parameters specified in table 7.4.1.1 the average downlink $\frac{DPCH - E_c}{I_{or}}$ power ratio shall be below the specified value for the BLER shown in table 7.4.1.2.

Table 7.4.1.1: DCH parameters in moving propagation conditions

Parameter	Test 1	Test 2	Unit
Phase reference		P-CPICH	
\hat{I}_{or}/I_{oc}		-1	dB
I_{oc}		-60	dBm / 3,84 MHz
Information Data Rate	12,2	64	kbps

Table 7.4.1.2: DCH requirements in moving propagation conditions

Test Number	$\frac{DPCH - E_c}{I_{or}}$	BLER
1	-14,5 dB	10^{-2}
2	-10,9 dB	10^{-2}

The reference for this requirement is TS 25.101 [1] clause 8.4.1.1.

7.4.1.3 Test purpose

To verify the ability of the receiver to receive a predefined test signal, representing a moving propagation channel for the wanted and for the co-channel signals from serving and adjacent cells, with a BLER not exceeding a specified value.

7.4.1.4 Method of test

7.4.1.4.1 Initial conditions

Test environment: normal; see clauses G.2.1 and G.2.2.

Frequencies to be tested: mid range; see clause G.2.4.

1. Connect the SS and an AWGN noise source to the UE antenna connector as shown in figure A.10.
2. Set up a call according to the Generic call setup procedure TS34.108 [3] sub clause 7.3.2.
3. Set the test parameters as specified in table 7.4.1.3.
4. Enter the UE into loopback test mode and start the loopback test.
5. Setup fading simulator as moving propagation condition, which is described in clause D.2.3.

7.4.1.4.2 Procedures

1. Measure BLER of DCH.

7.4.1.5 Test requirements

For the parameters specified in table 7.4.1.3 the average downlink $\frac{DPCH - E_c}{I_{or}}$ power ratio shall be below the specified value for the BLER shown in table 7.4.1.4.

Table 7.4.1.3: DCH parameters in moving propagation conditions

Parameter	Test 1	Test 2	Unit
Phase reference \hat{I}_{or}/I_{oc}		P-CPICH -0,4	dB
I_{oc}		-60	dBm / 3,84 MHz
Information Data Rate	12,2	64	kbps

Table 7.4.1.4: DCH requirements in moving propagation conditions

Test Number	$\frac{DPCH - E_c}{I_{or}}$	BLER
1	-14,4 dB	10^{-2}
2	-10,8 dB	10^{-2}

NOTE: If the above Test Requirement differs from the Minimum Requirement then the Test Tolerance applied for this test is non-zero. The Test Tolerance for this test is defined in clause F.2 and the explanation of how the Minimum Requirement has been relaxed by the Test Tolerance is given in clause F.4.

7.5 Demodulation of DCH in Birth-Death Propagation conditions

7.5.1 Single Link Performance

7.5.1.1 Definition and applicability

The receive single link performance of the Dedicated Channel (DCH) in dynamic birth-death propagation conditions are determined by the Block Error Ratio (BLER) values. BLER is measured for the each of the individual data rate specified for the DPCH. DCH is mapped into Dedicated Physical Channel (DPCH).

The UE shall be tested only according to the data rate, supported. The data-rate-corresponding requirements shall apply to the UE.

7.5.1.2 Minimum requirements

For the parameters specified in table 7.5.1.1 the average downlink $\frac{DPCH - E_c}{I_{or}}$ power ratio shall be below the specified value for the BLER shown in table 7.5.1.2.

Table 7.5.1.1: DCH parameters in birth-death propagation conditions

Parameter	Test 1	Test 2	Unit
Phase reference		P-CPICH	
\hat{I}_{or}/I_{oc}		-1	dB
I_{oc}		-60	dBm / 3,84 MHz
Information Data Rate	12,2	64	kbps

Table 7.5.1.2: DCH requirements in birth-death propagation conditions

Test Number	$\frac{DPCH - E_c}{I_{or}}$	BLER
1	-12,6 dB	10^{-2}
2	-8,7 dB	10^{-2}

The reference for this requirement is TS 25.101 [1] clause 8.5.1.1.

7.5.1.3 Test purpose

To verify the ability of the receiver to receive a predefined test signal, representing a birth-death propagation channel for the wanted and for the co-channel signals from serving and adjacent cells, with a BLER not exceeding a specified value.

7.5.1.4 Method of test

7.5.1.4.1 Initial conditions

Test environment: normal; see clauses G.2.1 and G.2.2.

Frequencies to be tested: mid range; see clause G.2.4.

1. Connect the SS and an AWGN noise source to the UE antenna connector as shown in figure A.10.
2. Set up a call according to the Generic call setup procedure TS34.108 [3] sub clause 7.3.2.
3. Set the test parameters as specified in table 7.5.1.3.
4. Enter the UE into loopback test mode and start the loopback test.
5. Setup fading simulator as birth-death propagation condition, which is described in clause D.2.4.

7.5.1.4.2 Procedures

1. Measure BLER of DCH.

7.5.1.5 Test requirements

For the parameters specified in table 7.5.1.3 the average downlink $\frac{DPCH - E_c}{I_{or}}$ power ratio shall be below the specified value for the BLER shown in table 7.5.1.4.

Table 7.5.1.3: DCH parameters in birth-death propagation conditions

Parameter	Test 1	Test 2	Unit
Phase reference		P-CPICH	
\hat{I}_{or}/I_{oc}		-0,4	dB
I_{oc}		-60	dBm / 3,84 MHz
Information Data Rate	12,2	64	kbps

Table 7.5.1.4: DCH requirements in birth-death propagation conditions

Test Number	$\frac{DPCH_E_c}{I_{or}}$	BLER
1	-12,5 dB	10^{-2}
2	-8,6 dB	10^{-2}

NOTE: If the above Test Requirement differs from the Minimum Requirement then the Test Tolerance applied for this test is non-zero. The Test Tolerance for this test is defined in clause F.2 and the explanation of how the Minimum Requirement has been relaxed by the Test Tolerance is given in clause F.4.

7.5A Demodulation of DCH in high speed train condition

7.5A.1 Single Link Performance

7.5A.1.1 Definition and applicability

The receive single link performance of the Dedicated Channel (DCH) in high speed train conditions are determined by the Block Error Ratio (BLER) values. BLER is measured for the each of the individual data rate specified for the DPCH. DCH is mapped into Dedicated Physical Channel (DPCH).

The data-rate-corresponding requirements shall apply to the UE for Release 7 and later releases.

7.5A.1.2 Minimum requirement

For the parameters specified in Table 7.5A.1.1 the average downlink $\frac{DPCH_E_c}{I_{or}}$ power ratio shall be below the specified value for the BLER shown in Table 7.5A.2.

Table 7.5A.1.1: DCH parameters in high speed train condition

Parameter	Unit	Test 1
Phase reference		P-CPICH
\hat{I}_{or}/I_{oc}	dB	5
I_{oc}	dBm/3.84 MHz	-60
Information Data Rate	kbps	12.2

Table 7.5A.1.2: DCH requirements in high speed train condition

Test Number	$\frac{DPCH_E_c}{I_{or}}$	BLER
1	-21.8	10^{-2}

The reference for this requirement is TS 25.101 [1] clause 8.5A.1.1.

7.5A.1.3 Test purpose

To verify the ability of the receiver to receive a predefined test signal, representing a high speed train channel for the wanted and for the co-channel signals from serving and adjacent cells, with a BLER not exceeding a specified value.

7.5A.1.4 Method of test

7.5A.1.4.1 Initial conditions

Test environment: normal; see clauses G.2.1 and G.2.2.

Frequencies to be tested: mid range; see clause G.2.4.

1. Connect the SS and an AWGN noise source to the UE antenna connector as shown in figure A.10.
2. Set up a call according to the Generic call setup procedure in TS34.108[3] sub clause 7.3.2.
3. Set the test parameters as specified in table 7.5A.1.3.
4. Enter the UE into loopback test mode and start the loopback test.
5. Setup fading simulator as High speed train conditions, which is described in clause D.2.4A.

7.5A.1.4.2 Procedures

1. Measure BLER of DCH.

7.5A.1.5 Test requirements

For the parameters specified in table 7.5A.1.3 the average downlink $\frac{DPCH_E_c}{I_{or}}$ power ratio shall be below the specified value for the BLER shown in table 7.5A.1.4.

Table 7.5A.1.3: DCH parameters in high speed train condition

Parameter	Unit	Test 1
Phase reference		P-CPICH
\hat{I}_{or}/I_{oc}	dB	5.6
I_{oc}	dBm/3.84 MHz	-60
Information Data Rate	kbps	12.2

Table 7.5A.1.4: DCH requirements in high speed train condition

Test Number	$\frac{DPCH_E_c}{I_{or}}$	BLER
1	-21.7	10^{-2}

NOTE: If the above Test Requirement differs from the Minimum Requirement then the Test Tolerance applied for this test is non-zero. The Test Tolerance for this test is defined in clause F.2 and the explanation of how the Minimum Requirement has been relaxed by the Test Tolerance is given in clause F.4.

7.6 Demodulation of DCH in downlink Transmit diversity modes

7.6.1 Demodulation of DCH in open-loop transmit diversity mode

7.6.1.1 Definition and applicability

The receive characteristic of the Dedicated Channel (DCH) in open loop transmit diversity mode is determined by the Block Error Ratio (BLER). DCH is mapped into in Dedicated Physical Channel (DPCH).

The requirements and this test apply to all types of UTRA for the FDD UE.

7.6.1.2 Minimum requirements

For the parameters specified in table 7.6.1.1 the average downlink $\frac{DPCH_E_c}{I_{or}}$ power ratio shall be below the specified value for the BLER shown in table 7.6.1.2.

Table 7.6.1.1: Test parameters for DCH reception in a open-loop transmit diversity scheme (Propagation condition: Case 1)

Parameter	Test 1	Unit
Phase reference	P-CPICH	
\hat{I}_{or}/I_{oc}	9	dB
I_{oc}	-60	dBm / 3,84 MHz
Information data rate	12,2	kbps

Table 7.6.1.2: Test requirements for DCH reception in open-loop transmit diversity scheme

Test Number	$\frac{DPCH_E_c}{I_{or}}$ (antenna 1/2)	BLER
1	-16,8 dB	10^{-2}

The reference for this requirement is TS 25.101 [1] clause 8.6.1.1.

7.6.1.3 Test purpose

To verify that UE reliably demodulates the DPCH of the Node B while open loop transmit diversity is enabled during the connection.

7.6.1.4 Method of test

7.6.1.4.1 Initial conditions

Test environment: normal; see clauses G.2.1 and G.2.2.

Frequencies to be tested: mid range; see clause G.2.4.

- 1) Connect SS, multi-path fading simulators and an AWGN source to the UE antenna connector as shown in figure A.12.
- 2) Set up a call according to the Generic call setup procedure specified in TS 34.108 [3] clause 7.3.2, with the exceptions for information elements listed in table 7.6.1.3. With these exceptions, open-loop transmit diversity mode is activated.
- 3) RF parameters are set up according to table 7.6.1.4 and table E 3.4.
- 4) Enter the UE into loopback test mode and start the loopback test.
- 5) Set up fading simulators as fading condition case 1, which is described in table D.2.2.1.

See TS 34.108 [3] and TS 34.109 [4] for details regarding generic call setup procedure and loopback test.

Table 7.6.1.3: Specific Message Contents for open-loop transmit diversity mode

SYSTEM INFORMATION BLOCK TYPE5

Information Element	Value/remark
PRACH system information list - AICH info - STTD Indicator	TRUE
Secondary CCPCH system information - PICH info - STTD Indicator - Secondary CCPCH info - STTD Indicator	TRUE TRUE
Primary CCPCH info - CHOICE mode - TX Diversity indicator	FDD TRUE

SYSTEM INFORMATION BLOCK TYPE11

Information Element	Value/remark
New intra-frequency cells - Intra-frequency cell id	1
- TX Diversity indicator	TRUE

RRC CONNECTION SETUP

Information Element	Value/remark
Downlink information common for all radio links - CHOICE mode - TX Diversity Mode	FDD STTD,
Downlink DPCH info for each RL - CHOICE mode - Downlink DPCH info for each RL - Closed loop timing adjustment mode	FDD 1

RADIO BEARER SETUP

Information Element	Value/remark
Downlink information common for all radio links - Choice mode - TX Diversity Mode	FDD STTD
Downlink DPCH info for each RL - CHOICE mode - Downlink DPCH info for each RL - Closed loop timing adjustment mode	FDD 1

7.6.1.4.2 Procedure

- 1) Measure BLER in points specified in table 7.6.1.5.

7.6.1.5 Test Requirements

For the parameters specified in table 7.6.1.4 the average downlink $\frac{DPCH - E_c}{I_{or}}$ power ratio shall be below the specified value for the BLER shown in table 7.6.1.5.

Table 7.6.1.4: Test parameters for DCH reception in an open-loop transmit diversity scheme (Propagation condition: Case 1)

Parameter	Test 1	Unit
Phase reference	P-CPICH	
\hat{I}_{or}/I_{oc}	9,8	dB
I_{oc}	-60	dBm / 3,84 MHz
Information data rate	12,2	kbps

Table 7.6.1.5: Test requirements for DCH reception in open-loop transmit diversity scheme

Test Number	$\frac{DPCH_E_c}{I_{or}}$ (antenna 1/2)	BLER
1	-16,7 dB	10^{-2}

NOTE: If the above Test Requirement differs from the Minimum Requirement then the Test Tolerance applied for this test is non-zero. The Test Tolerance for this test is defined in clause F.2 and the explanation of how the Minimum Requirement has been relaxed by the Test Tolerance is given in clause F.4.

7.6.2 Demodulation of DCH in closed loop transmit diversity mode

7.6.2.1 Definition and applicability

The receive characteristic of the dedicated channel (DCH) in closed loop transmit diversity mode is determined by the Block Error Ratio (BLER). DCH is mapped into in Dedicated Physical Channel (DPCH).

The requirements for Closed loop mode 1 and test 1 apply to all types of UTRA for the FDD UE. The requirements for Closed loop mode 2 and test 2 apply to all types of UTRA for the FDD UE for Release 99 and Release 4 only.

7.6.2.2 Minimum requirements

For the parameters specified in table 7.6.2.1 the average downlink $\frac{DPCH_E_c}{I_{or}}$ power ratio shall be below the specified value for the BLER shown in table 7.6.2.2.

Table 7.6.2.1: Test Parameters for DCH Reception in closed loop transmit diversity mode (Propagation condition: Case 1)

Parameter	Test 1 (Mode 1)	Test 2 (Mode 2)	Unit
\hat{I}_{or}/I_{oc}	9	9	dB
I_{oc}	-60	-60	dBm / 3,84 MHz
Information data rate	12,2	12,2	kbps
Feedback error ratio	4	4	%
Closed loop timing adjustment mode	1	1	-

Table 7.6.2.2: Test requirements for DCH reception in closed loop transmit diversity mode

Test Number	$\frac{DPCH_E_c}{I_{or}}$ (see note)	BLER
1	-18,0 dB	10^{-2}
2	-18,3 dB	10^{-2}
NOTE: This is the total power from both antennas. Power sharing between antennas are closed loop mode dependent as specified in TS 25.214 [5].		

The reference for this requirement is TS 25.101 [1] clause 8.6.2.1.

7.6.2.3 Test purpose

To verify that UE reliably demodulates the DPCH of the Node B while closed loop transmit diversity is enabled during the connection.

7.6.2.4 Method of test

7.6.2.4.1 Initial conditions

Test environment: normal; see clauses G.2.1 and G.2.2.

Frequencies to be tested: mid range; see clause G.2.4.

- 1) Connect SS, multi-path fading simulators and an AWGN source to the UE antenna connector as shown in figure A.12.
- 2) Set up a call according to the Generic call setup procedure specified in TS 34.108 [3] clause 7.3.2, with the exceptions for information elements listed in table 7.6.2.3. With these exceptions, closed loop transmit diversity mode is activated.
- 3) RF parameters are set up according to table 7.6.2.1 and table E 3.5.
- 4) Enter the UE into loopback test mode and start the loopback test.
- 5) Set up fading simulators as fading condition case 1, which is described in table D.2.2.1.

See TS 34.108 [3] and TS 34.109 [4] for details regarding generic call setup procedure and loopback test.

Table 7.6.2.3: Specific Message Contents for closed loop transmit diversity mode

SYSTEM INFORMATION BLOCK TYPE5

Information Element	Value/remark
PRACH system information list - AICH info - STTD Indicator	TRUE
Secondary CCPCH system information - PICH info - STTD Indicator - Secondary CCPCH info - STTD Indicator	TRUE TRUE
Primary CCPCH info - CHOICE mode - TX Diversity indicator	FDD TRUE

SYSTEM INFORMATION BLOCK TYPE11

Information Element	Value/remark
New intra-frequency cells - Intra-frequency cell id	1
- TX Diversity indicator	TRUE

RRC CONNECTION SETUP for Closed loop mode1

Information Element	Value/remark
CHOICE channel requirement	Uplink DPCH info
- Number of FBI bit	1
Downlink information common for all radio links - CHOICE mode - TX Diversity Mode	FDD Closed loop mode1
Downlink DPCH info for each RL - CHOICE mode - Downlink DPCH info for each RL - Closed loop timing adjustment mode	FDD 1

RRC CONNECTION SETUP for Closed loop mode2

Information Element	Value/remark
CHOICE channel requirement	Uplink DPCH info
- Number of FBI bit	1
Downlink information common for all radio links - CHOICE mode - TX Diversity Mode	FDD Closed loop mode2
Downlink DPCH info for each RL - CHOICE mode - Downlink DPCH info for each RL - Closed loop timing adjustment mode	FDD 1

RADIO BEARER SETUP for Closed loop mode1

Information Element	Value/remark
CHOICE channel requirement	Uplink DPCH info
- Number of FBI bit	1
Downlink information common for all radio links - Choice mode - TX Diversity Mode	FDD Closed loop mode1
Downlink DPCH info for each RL - CHOICE mode - Downlink DPCH info for each RL - Closed loop timing adjustment mode	FDD 1

RADIO BEARER SETUP for Closed loop mode2

Information Element	Value/remark
CHOICE channel requirement	Uplink DPCH info
- Number of FBI bit	1
Downlink information common for all radio links - Choice mode - TX Diversity Mode	FDD Closed loop mode2
Downlink DPCH info for each RL - CHOICE mode - Downlink DPCH info for each RL - Closed loop timing adjustment mode	FDD 1

7.6.2.4.2 Procedure

- 1) Measure BLER in points specified in table 7.6.2.2.

7.6.2.5 Test Requirements

For the parameters specified in table 7.6.2.4 the average downlink $\frac{DPCH - E_c}{I_{or}}$ power ratio shall be below the specified value for the BLER shown in table 7.6.2.5.

Table 7.6.2.4: Test Parameters for DCH Reception in closed loop transmit diversity mode (Propagation condition: Case 1)

Parameter	Test 1 (Mode 1)	Test 2 (Mode 2)	Unit
\hat{I}_{or}/I_{oc}	9,8	9,8	dB
I_{oc}	-60	-60	dBm / 3,84 MHz
Information data rate	12,2	12,2	kbps
Feedback error ratio (*)	4	4	%
Closed loop timing adjustment mode	1	1	-
* Note: As the uplink is error free, the feedback error ratio is generated by the SS internally as follows: 4% of the feedback bits, received by the SS on the uplink, shall be inverted prior to being processed. The inverted bits shall occur at random, e.g controlled by a random generator.			

Table 7.6.2.5: Test requirements for DCH reception in closed loop transmit diversity mode

Test Number	$\frac{DPCH_E_c}{I_{or}}$ (see note)	BLER
1	-17,9 dB	10^{-2}
2	-18,2 dB	10^{-2}
NOTE: This is the total power from both antennas. Power sharing between antennas are closed loop mode dependent as specified in TS 25.214 [5].		

NOTE: If the above Test Requirement differs from the Minimum Requirement then the Test Tolerance applied for this test is non-zero. The Test Tolerance for this test is defined in clause F.2 and the explanation of how the Minimum Requirement has been relaxed by the Test Tolerance is given in clause F.4.

7.6.3 Demodulation of DCH in Site Selection Diversity Transmission Power Control mode

7.6.3.1 Definition and applicability

The bit error characteristics of UE receiver is determined in Site Selection Diversity Transmission Power Control (SSDT) mode. Two Node B emulators are required for this performance test. The delay profiles of signals received from different base stations are assumed to be the same but time shifted by 10 chip periods.

The requirements and this test apply to all types of UTRA for the Release 99 and Release 4 FDD UE.

7.6.3.2 Minimum requirements

The downlink physical channels and their relative power to I_{or} are the same as those specified in clause E.3.3 irrespective of Node Bs and the test cases. $DPCH_E_c/I_{or}$ value applies whenever DPDCH in the cell is transmitted. In Test 1 and Test 3, the received powers at UE from two Node Bs are the same, while 3dB offset is given to one that comes from one of Node Bs for Test 2 and Test 4 as specified in table 7.6.3.1.

For the parameters specified in table 7.6.3.1 the average downlink $\frac{DPCH_E_c}{I_{or}}$ power ratio shall be below the specified value for the BLER shown in table 7.6.3.2.

Table 7.6.3.1: DCH parameters in multi-path propagation conditions during SSDT mode (Propagation condition: Case 1)

Parameter	Test 1	Test 2	Test 3	Test 4	Unit
Phase reference	P-CPICH				
\hat{I}_{or1}/I_{oc}	0	-3	0	0	dB
\hat{I}_{or2}/I_{oc}	0	0	0	-3	dB
I_{oc}	-60				dBm / 3,84 MHz
Information Data Rate	12,2	12,2	12,2	12,2	kbps
Cell ID code word error ratio in uplink (note)	1	1	1	1	%
Number of FBI bits assigned to "S" Field	1	1	2	2	
Code word Set	Long	Long	Short	Short	
UL DPCCH slot Format	#2		#5		
NOTE:	The code word errors are introduced independently in both uplink channels.				

Table 7.6.3.2: DCH requirements in multi-path propagation conditions during SSDT Mode

Test Number	$\frac{DPCH_E_c}{I_{or}}$	BLER
1	-6,0 dB	10^{-2}
2	-5,0 dB	10^{-2}
3	-10,5 dB	10^{-2}
4	-9,2 dB	10^{-2}

The reference for this requirement is TS 25.101 [1] clause 8.6.3.1.

7.6.3.3 Test purpose

To verify that UE reliably demodulates the DPCH of the selected Node B while site selection diversity is enabled during soft handover.

7.6.3.4 Method of test

7.6.3.4.1 Initial conditions

Test environment: normal; see clauses G.2.1 and G.2.2.

Frequencies to be tested: mid range; see clause G.2.4.

- 1) Connect two SS's, multi-path fading simulators and an AWGN source to the UE antenna connector as shown in figure A.11.
- 2) Activate one of two cells (Cell 1).
- 3) Set up a call according to the Generic call setup procedure specified in TS 34.108 [3] clause 7.3.2, with the exceptions for information elements listed in table 7.6.3.3A. With these exceptions, necessary information for SSDT mode is sent to the UE.
- 4) Activate the other cell (Cell 2) on the other SS.
- 5) RF parameters are set up according to table 7.6.3.4 and table 7.6.3.5
- 6) After receiving MEASUREMENT REPORT message from the UE, send the ACTIVESET UPDATE message from Cell 1 to the UE in order to activate SSDT mode. Contents of the message is specified in table 7.6.3.3B
- 7) Enter the UE into loopback test mode and start the loopback test.
- 8) Set up fading simulators as fading condition case 1, which is described in table D.2.2.1.

Table 7.6.3.3A: Specific Message Contents for SSDT mode

RRC CONNECTION SETUP for Test 1 and Test 2

Information Element	Value/remark
Downlink information common for all radio links - CHOICE mode - SSDT information - S field - Code Word Set	FDD 1 long
Downlink DPCH info for each RL - CHOICE mode - Downlink DPCH info for each RL - SSDT Cell Identity	FDD a

RRC CONNECTION SETUP for Test 3 and Test 4

Information Element	Value/remark
Downlink information common for all radio links - CHOICE mode - SSDT information - S field - Code Word Set	FDD 2 short
Downlink DPCH info for each RL - CHOICE mode - Downlink DPCH info for each RL - SSDT Cell Identity	FDD a

RADIO BEARER SETUP for Test 1 and Test 2

Information Element	Value/remark
Downlink information common for all radio links - CHOICE mode - SSDT information - S field - Code Word Set	FDD 1 long
Downlink DPCH info for each RL - CHOICE mode - Downlink DPCH info for each RL - SSDT Cell Identity	FDD a

RADIO BEARER SETUP for Test 3 and Test 4

Information Element	Value/remark
Downlink information common for all radio links - CHOICE mode - SSDT information - S field - Code Word Set	FDD 2 short
Downlink DPCH info for each RL - CHOICE mode - Downlink DPCH info for each RL - SSDT Cell Identity	FDD a

Table 7.6.3.3B: Message Contents of ACTIVESET UPDATE message

ACTIVESET UPDATE for Test 1 and Test 2

Information Element/Group name	Value/Remark
Message Type (10.2.17)	
UE information elements - RRC transaction identifier - Integrity check info - message authentication code - RRC message sequence number - Activation time - New U-RNTI	0 SS calculates the value of MAC-I for this message and writes to this IE. The first/ leftmost bit of the bit string contains the most significant bit of the MAC-I. SS provides the value of this IE, from its internal counter. "now". Not Present
CN information elements - CN Information info	Not Present
Phy CH information elements Uplink radio resources - Maximum allowed UL TX power	33 dBm
Downlink radio resources - Radio link addition information - Radio link addition information - Primary CPICH info - Downlink DPCH info for each RL	1 Same as defined in Cell2
- CHOICE mode - Primary CPICH usage for channel estimation - DPCH frame offset - Secondary CPICH info	FDD Primary CPICH may be used This should be reflected by the IE" Cell synchronisation information" in received MEASUREMENT REPORT message Not Present
- DL channelisation code - Secondary scrambling code - Spreading factor - Code number - Scrambling code change - TPC combination index - SSDT Cell Identity - Closed loop timing adjustment mode - TFCI combining indicator - SCCPCH Information for FACH - Radio link removal information - TX Diversity Mode	Not Present 128 96 No code change 0 b Not Present FALSE Not Present Not Present None
- SSDT information - S field - Code Word Set	1 long

ACTIVESET UPDATE for Test 3 and Test 4

Information Element/Group name	Value/Remark
Message Type (10.2.17)	
UE information elements - RRC transaction identifier - Integrity check info - message authentication code - RRC message sequence number - Activation time - New U-RNTI	0 SS calculates the value of MAC-I for this message and writes to this IE. The first/ leftmost bit of the bit string contains the most significant bit of the MAC-I. SS provides the value of this IE, from its internal counter. "now". Not Present
CN information elements - CN Information info	Not Present
Phy CH information elements Uplink radio resources - Maximum allowed UL TX power	33 dBm
Downlink radio resources - Radio link addition information - Radio link addition information - Primary CPICH info - Downlink DPCH info for each RL	1 Same as defined in Cell2
- CHOICE mode - Primary CPICH usage for channel estimation - DPCH frame offset - Secondary CPICH info	FDD Primary CPICH may be used This should be reflected by the IE " Cell synchronisation information" in received MEASUREMENT REPORT message Not Present
- DL channelisation code - Secondary scrambling code - Spreading factor - Code number - Scrambling code change - TPC combination index - SSDT Cell Identity - Closed loop timing adjustment mode - TFCI combining indicator - SCCPCH Information for FACH - Radio link removal information - TX Diversity Mode	Not Present 128 96 No code change 0 b Not Present FALSE Not Present Not Present None
- SSDT information - S field - Code Word Set	2 short

7.6.3.4.2 Procedure

Measure BLER in points specified in table 7.6.3.4.

7.6.3.5 Test Requirements

For the parameters specified in table 7.6.3.4 the average downlink $\frac{DPCH - E_c}{I_{or}}$ power ratio shall be below the specified value for the BLER shown in table 7.6.3.5.

Table 7.6.3.4: DCH parameters in multi-path propagation conditions during SSDT mode (Propagation condition: Case 1)

Parameter	Test 1	Test 2	Test 3	Test 4	Unit
Phase reference	P-CPICH				
\hat{I}_{or1}/I_{oc}	0,8	-2,2	0,8	0,8	dB
\hat{I}_{or2}/I_{oc}	0,8	0,8	0,8	-2,2	dB
I_{oc}	-60				dBm / 3,84 MHz
Information Data Rate	12,2	12,2	12,2	12,2	kbps
Cell ID code word error ratio in uplink (note)	1	1	1	1	%
Number of FBI bits assigned to "S" Field	1	1	2	2	
Code word Set	Long	Long	Short	Short	
UL DPCCH slot Format	#2		#5		
NOTE:	The code word errors are introduced independently in both uplink channels.				

Table 7.6.3.5: DCH requirements in multi-path propagation conditions during SSDT mode

Test Number	$\frac{DPCH_E_c}{I_{or}}$	BLER
1	-5,9 dB	10^{-2}
2	-4,9 dB	10^{-2}
3	-10,4 dB	10^{-2}
4	-9,1 dB	10^{-2}

NOTE: If the above Test Requirement differs from the Minimum Requirement then the Test Tolerance applied for this test is non-zero. The Test Tolerance for this test is defined in clause F.2 and the explanation of how the Minimum Requirement has been relaxed by the Test Tolerance is given in clause F.4.

7.7 Demodulation in Handover conditions

7.7.1 Demodulation of DCH in Inter-Cell Soft Handover (Release 5 and earlier)

7.7.1.1 Definition and applicability

The bit error ratio characteristics of UE is determined during an inter-cell soft handover. During the soft handover a UE receives signals from different Base Stations. A UE has to be able to demodulate two P-CCPCH channels and to combine the energy of DCH channels. Delay profiles of signals received from different Base Stations are assumed to be the same but time shifted by 10 chips.

The receive characteristics of the different channels during inter-cell handover are determined by the Block Error Ratio (BLER) values.

The UE shall be tested only according to the data rate, supported. The data-rate-corresponding requirements shall apply to the UE. This test is applicable for Release 5 and earlier releases only.

7.7.1.2 Minimum requirements

For the parameters specified in table 7.7.1.1 the average downlink $\frac{DPCH_E_c}{I_{or}}$ power ratio shall be below the specified value for the BLER shown in table 7.7.1.2.

Table 7.7.1.1: DCH parameters in multi-path propagation conditions during Soft Handoff (Case 3)

Parameter	Test 1	Test 2	Test 3	Test 4	Unit
Phase reference			P-CPICH		
\hat{I}_{or1}/I_{oc} and \hat{I}_{or2}/I_{oc}	0	0	3	6	dB
I_{oc}			-60		dBm / 3,84 MHz
Information Data Rate	12,2	64	144	384	kbps

Table 7.7.1.2: DCH requirements in multi-path propagation conditions during Soft Handoff (Case 3)

Test Number	$\frac{DPCH_E_c}{I_{or}}$	BLER
1	-15,2 dB	10^{-2}
2	-11,8 dB	10^{-1}
	-11,3 dB	10^{-2}
3	-9,6 dB	10^{-1}
	-9,2 dB	10^{-2}
4	-6,0 dB	10^{-1}
	-5,5 dB	10^{-2}

The reference for this requirement is TS 25.101 [1] clause 8.7.1.1.

7.7.1.3 Test purpose

To verify that the BLER does not exceed the value at the $DPCH_E_c/I_{or}$ specified in table 7.7.1.2.

7.7.1.4 Method of test

7.7.1.4.1 Initial conditions

Test environment: normal; see clauses G.2.1 and G.2.2.

Frequencies to be tested: mid range; see clause G.2.4.

7.7.1.4.2 Procedures

- 1) Connect the SS, multi-path fading simulator and an AWGN noise source to the UE antenna connector as shown in figure A.11.
- 2) Set up the call according to the Generic call setup procedure specified in TS 34.108 [3] clause 7.3.2.
- 3) Set the test parameters for test 1-4 as specified in table 7.7.1.3.
- 4) Count, at the SS, the number of information blocks transmitted and the number of correctly received information blocks at the UE.
- 5) Measure BLER of DCH channel.

7.7.1.5 Test requirements

For the parameters specified in table 7.7.1.3 the average downlink $\frac{DPCH_E_c}{I_{or}}$ power ratio shall be below the specified value for the BLER shown in table 7.7.1.4.

Table 7.7.1.3: DCH parameters in multi-path propagation conditions during Soft Handoff (Case 3)

Parameter	Test 1	Test 2	Test 3	Test 4	Unit
Phase reference			P-CPICH		
\hat{I}_{or1}/I_{oc} and \hat{I}_{or2}/I_{oc}	0,6	0,6	3,6	6,6	dB
I_{oc}			-60		dBm / 3,84 MHz
Information Data Rate	12,2	64	144	384	kbps

Table 7.7.1.4: DCH requirements in multi-path propagation conditions during Soft Handoff (Case 3)

Test Number	$\frac{DPCH_E_c}{I_{or}}$	BLER
1	-15,1 dB	10^{-2}
2	-11,7 dB	10^{-1}
	-11,2 dB	10^{-2}
3	-9,5 dB	10^{-1}
	-9,1 dB	10^{-2}
4	-5,9 dB	10^{-1}
	-5,4 dB	10^{-2}

NOTE: If the above Test Requirement differs from the Minimum Requirement then the Test Tolerance applied for this test is non-zero. The Test Tolerance for this test is defined in clause F.2 and the explanation of how the Minimum Requirement has been relaxed by the Test Tolerance is given in clause F.4.

7.7.1A Demodulation of DCH in Inter-Cell Soft Handover (Release 6 and later)

7.7.1A.1 Definition and applicability

The bit error ratio characteristics of UE is determined during an inter-cell soft handover. During the soft handover a UE receives signals from different Base Stations. A UE has to be able to demodulate two P-CCPCH channels and to combine the energy of DCH channels. Delay profiles of signals received from different Base Stations are assumed to be the same but time shifted by 10 chips.

The receive characteristics of the different channels during inter-cell handover are determined by the Block Error Ratio (BLER) values.

The UE shall be tested only according to the data rate, supported. The data-rate-corresponding requirements shall apply to the UE. This test is applicable for Release 6 and later releases only.

7.7.1A.2 Minimum requirements

For the parameters specified in table 7.7.1A.1 the average downlink $\frac{DPCH_E_c}{I_{or}}$ power ratio shall be below the specified value for the BLER shown in table 7.7.1A.2.

Table 7.7.1A.1: DCH parameters in multi-path propagation conditions during Soft Handoff (Case 3)

Parameter	Test 1	Test 2	Test 3	Test 4	Unit
Phase reference			P-CPICH		
\hat{I}_{or1}/I_{oc} and \hat{I}_{or2}/I_{oc}	0	0	3	6	dB
I_{oc}			-60		dBm / 3,84 MHz
Information Data Rate	12,2	64	144	384	kbps

Table 7.7.1A.2: DCH requirements in multi-path propagation conditions during Soft Handoff (Case 3)

Test Number	$\frac{DPCH_E_c}{I_{or}}$	BLER
1	-15,2 dB	10^{-2}
2	-11,8 dB	10^{-1}
	-11,3 dB	10^{-2}
3	-9,9 dB	10^{-1}
	-9,5 dB	10^{-2}
4	-6,3 dB	10^{-1}
	-5,8 dB	10^{-2}

The reference for this requirement is TS 25.101 [1] clause 8.7.1A.1.

7.7.1A.3 Test purpose

To verify that the BLER does not exceed the value at the $DPCH_E_c/I_{or}$ specified in table 7.7.1A.2.

7.7.1A.4 Method of test

7.7.1A.4.1 Initial conditions

Test environment: normal; see clauses G.2.1 and G.2.2.

Frequencies to be tested: mid range; see clause G.2.4.

7.7.1A.4.2 Procedures

- 1) Connect the SS, multi-path fading simulator and an AWGN noise source to the UE antenna connector as shown in figure A.11.
- 2) Set up the call according to the Generic call setup procedure specified in TS 34.108 [3] clause 7.3.2.
- 3) Set the test parameters for test 1-4 as specified in table 7.7.1A.3.
- 4) Count, at the SS, the number of information blocks transmitted and the number of correctly received information blocks at the UE.
- 5) Measure BLER of DCH channel.

7.7.1A.5 Test requirements

For the parameters specified in table 7.7.1A.3 the average downlink $\frac{DPCH_E_c}{I_{or}}$ power ratio shall be below the specified value for the BLER shown in table 7.7.1A.4.

Table 7.7.1A.3: DCH parameters in multi-path propagation conditions during Soft Handoff (Case 3)

Parameter	Test 1	Test 2	Test 3	Test 4	Unit
Phase reference					
\hat{I}_{or1}/I_{oc} and \hat{I}_{or2}/I_{oc}	0,6	0,6	3,6	6,6	dB
I_{oc}			-60		dBm / 3,84 MHz
Information Data Rate	12,2	64	144	384	kbps

Table 7.7.1A.4: DCH requirements in multi-path propagation conditions during Soft Handoff (Case 3)

Test Number	$\frac{DPCH_E_c}{I_{or}}$	BLER
1	-15,1 dB	10^{-2}
2	-11,7 dB	10^{-1}
	-11,2 dB	10^{-2}
3	-9,8 dB	10^{-1}
	-9,4 dB	10^{-2}
4	-6,2 dB	10^{-1}
	-5,7 dB	10^{-2}

NOTE: If the above Test Requirement differs from the Minimum Requirement then the Test Tolerance applied for this test is non-zero. The Test Tolerance for this test is defined in clause F.2 and the explanation of how the Minimum Requirement has been relaxed by the Test Tolerance is given in clause F.4.

7.7.2 Combining of TPC commands from radio links of different radio link sets

7.7.2.1 Definition and applicability

When a UE is in soft handover, multiple TPC commands may be received in each slot from different cells in the active set. In general, the TPC commands transmitted in the same slot in the different cells may be different and need to be combined to give TPC_cmd as specified in TS 25.214 [5], in order to determine the required uplink power step.

The requirements and this test apply to all types of UTRA for the FDD UE.

7.7.2.2 Minimum requirements

Test parameters are specified in table 7.7.2.1. The delay profiles of the signals received from the different cells are the same but time-shifted by 10 chips.

For Test 1, the sequence of uplink power changes between adjacent slots shall be as shown in table 7.7.2.2 over the 4 consecutive slots more than 99% of the time. Note that this case is without an additional noise source I_{oc} .

For Test 2, the Cell1 and Cell2 TPC patterns are repeated a number of times. If the transmitted power of a given slot is increased compared to the previous slot, then a variable "Transmitted power UP" is increased by one, otherwise a variable "Transmitted power DOWN" is increased by one. The requirements for "Transmitted power UP" and "Transmitted power DOWN" are shown in table 7.7.2.3.

Table 7.7.2.1: Parameters for TPC command combining

Parameter	Test 1	Test 2	Unit
Phase reference		P-CPICH	-
DPCH_Ec/I _{or}		-12	dB
\hat{I}_{or1} and \hat{I}_{or2}		-60	dBm / 3,84 MHz
I_{oc}	-	-60	dBm / 3,84 MHz
Power-Control-Algorithm		Algorithm 1	-
Cell 1 TPC commands over 4 slots		{0,0,1,1}	-
Cell 2 TPC commands over 4 slots		{0,1,0,1}	-
Information Data Rate		12,2	Kbps
Propagation condition	Static without AWGN source I_{oc}	Multi-path fading case 3	-

Table 7.7.2.2: Requirements for Test 1

Test Number	Required power changes over the 4 consecutive slots
1	Down, Down, Down, Up

Table 7.7.2.3: Requirements for Test 2

Test Number	Ratio (Transmitted power UP) / (Total number of slots)	Ratio (Transmitted power DOWN) / (Total number of slots)
2	≥0,25	≥0,5

The reference for this requirement is TS 25.101 [1] clause 8.7.2.1.

7.7.2.3 Test purpose

To verify that the combining of TPC commands received in soft handover results in TPC_cmd being derived so as to meet the requirements stated in tables 7.7.2.2 and 7.7.2.3.

7.7.2.4 Method of test

7.7.2.4.1 Initial conditions

Test environment: normal; see clauses G.2.1 and G.2.2.

Frequencies to be tested: mid range; see clause G.2.4.

- 1) Connect two SS's to the UE antenna connector as shown in figure A.13.
- 2) Set the test parameters as specified in table 7.7.2.4 for Test 1.
- 3) Set up a call according to the Generic Call Setup procedure TS34.108 [3] sub clause 7.3.2.
- 4) Signal the uplink DPCH power control parameters to use Algorithm 1 and a step size of 1dB.
- 5) Enter the UE into loopback test mode and start the loopback test.

See TS 34.108 [3] and TS 34.109 [4] for details regarding the generic call setup procedure and loopback test.

7.7.2.4.2 Procedures

- 1) Before proceeding with paragraph (2), set the output power of the UE to be in the range -10 ± 9 dBm. This may be achieved by setting the downlink signal (\hat{I}_{OT}) to yield an appropriate open loop output power and/or by generating suitable downlink TPC commands from the SSs.
- 2) Send the following sequences of TPC commands in the downlink from each SS over a period of 5 timeslots:

	Downlink TPC commands				
	Slot #0	Slot #1	Slot #2	Slot #3	Slot #4
SS1	0	0	0	1	1
SS2	0	0	1	0	1

- 3) Measure the mean output power of the UE in timeslots # 0, 1, 2, 3 and 4, not including the 25 μ s transient periods at the start and end of each slot.
- 4) Repeat steps 1) to 3) according to Annex F.6.2 Table F.6.2.8.
- 5) End test 1 and disconnect UE.
- 6) Connect two SS's and an AWGN source to the UE antenna connector as shown in figure A.11.
- 7) Initialise variables "Transmitted power UP" and "Transmitted power DOWN" to zero.

- 8) Set the test parameters as specified in table 7.7.2.4 for Test 2.
- 9) Set up a call according to the Generic Call Setup procedure.
- 10) Signal the uplink DPCH power control parameters to use Algorithm 1 and a step size of 1 dB.
- 11) Enter the UE into loopback test mode and start the loopback test.
- 12) Perform the following steps a) to d) 193 times:
 - a) Before proceeding with step b), set the output power of the UE to be in the range -10 ± 9 dBm. This may be achieved by generating suitable downlink TPC commands from the SSs.
 - b) Send the following sequences of TPC commands in the downlink from each SS over a period of 33 timeslots:

	Downlink TPC commands
SS1	1 0 0 1 1 0 0 1 1 0 0 1 1 0 0 1 1 0 0 1 1 0 0 1 1 0 0 1 1 0 0 1 1
SS2	1 0 1 0 1 0 1 0 1 0 1 0 1 0 1 0 1 0 1 0 1 0 1 0 1 0 1 0 1 0 1 0 1 0 1

- c) Measure the mean output power of the UE in each timeslot, not including the 25 μ s transient periods at the start and end of each slot.
- d) For each timeslot from the 2nd timeslot to the 33rd timeslot inclusive:
 - if the mean power in that timeslot is greater than or equal to the mean power in the previous timeslot plus 0.4 dB, increment "Transmitted power UP" by 1;
 - if the mean power in that timeslot is less than or equal to the mean power in the previous timeslot minus 0.4 dB, increment "Transmitted power DOWN" by 1.

7.7.2.5 Test requirements

Test parameters are specified in table 7.7.2.4. The delay profiles of the signals received from the different cells are the same but time-shifted by 10 chips.

Table 7.7.2.4: Parameters for TPC command combining

Parameter	Test 1	Test 2	Unit
Phase reference		P-CPICH	-
DPCH_Ec/Ior		-11,9	dB
\hat{I}_{or1} and \hat{I}_{or2}	-60	-59.4	dBm / 3,84 MHz
I_{oc}	-	-60	dBm / 3,84 MHz
Power-Control-Algorithm		Algorithm 1	-
Cell 1 TPC commands over 4 slots		{0,0,1,1}	-
Cell 2 TPC commands over 4 slots		{0,1,0,1}	-
Information Data Rate		12,2	Kbps
Propagation condition	Static without AWGN	Multi-path fading case	-
	source I_{oc}	3	

- 1) In Step 3) of clause 7.7.2.4.2, the mean power in slot #1 shall be less than or equal to the mean power in slot #0 minus 0.4 dB.
- 2) In Step 3) of clause 7.7.2.4.2, the mean power in slot #2 shall be less than or equal to the mean power in slot #1 minus 0.4 dB.
- 3) In Step 3) of clause 7.7.2.4.2, the mean power in slot #3 shall be less than or equal to the mean power in slot #2 minus 0.4 dB.
- 4) In Step 3) of clause 7.7.2.4.2, the mean power in slot #4 shall be greater than or equal to the mean power in slot #3 plus 0.4 dB.
- 5) The sequence of test requirements 1-4 shall be fulfilled more than 99% of the time.

- 6) At the end of the test, "Transmitted power UP" shall be greater than or equal to 1443(23.36% of Total number of slots) and "Transmitted power DOWN" shall be greater than or equal to 2971(48.10% of total number of slots).

NOTE 1: The test limits in requirement (6) have been computed to give a confidence level of 99,7 % that a UE which follows the core requirements will pass while meeting the minimum test duration in Annex F table F.6.1.6.2 for multi-path fading environments. The number of timeslots has been chosen to get a good compromise between the test time and the risk of passing a bad UE.

NOTE 2: If the above Test Requirement differs from the Minimum Requirement then the Test Tolerance applied for this test is non-zero. The Test Tolerance for this test is defined in clause F.2 and the explanation of how the Minimum Requirement has been relaxed by the Test Tolerance is given in clause F.4.

7.7.3 Combining of reliable TPC commands from radio links of different radio link sets

7.7.3.1 Definition and applicability

When a UE is in soft handover, reliable TPC commands may be received in each slot from different cells in the active set. In general, the TPC commands transmitted in the same slot in the different cells may be different and need to be combined to give TPC_cmd as specified in TS 25.214 [5], in order to determine the required uplink power step.

The requirements and this test apply to all types of UTRA for the FDD UE.

7.7.3.2 Minimum requirements

Test parameters are specified in Table 7.7.3.1. Before the start of the tests, the UE transmit power shall be initialised to -15 dBm. An actual UE transmit power may vary from the target level of -15 dBm due to inaccurate UE output power step.

Test 1 verifies that the UE follows only the reliable TPC commands in soft handover. Test 2 verifies that the UE follows all the reliable TPC commands in soft handover.

During tests 1 and 2 the UE transmit power samples, which are defined as the mean power over one timeslot, shall stay 90% of the time within the range defined in Table 7.7.3.2.

Table 7.7.3.1: Parameters for reliable TPC command combining

Parameter	Unit	Test 1	Test 2
Phase reference	-	P-CPICH	
DPCH_Ec/Ior1	dB	Note 1	Note 1 & Note 3
DPCH_Ec/Ior2	dB	DPCH_Ec/Ior1 - 10	DPCH_Ec/Ior1 + 6
DPCH_Ec/Ior3	dB	DPCH_Ec/Ior1 - 10	-
\hat{I}_{or1}/I_{oc}	dB	-1	-1
\hat{I}_{or2}/I_{oc}	dB	-1	-1
\hat{I}_{or3}/I_{oc}	dB	-1	-
I_{oc}	dBm/3.84 MHz	-60	
Power-Control-Algorithm	-	Algorithm 1	
Cell 1 TPC commands	-	Note 2	Note 2
Cell 2 TPC commands	-	"1"	"1"
Cell 3 TPC commands	-	"1"	-
Information data Rate	Kbps	12.2	
Propagation condition	-	Static	
Note 1: The DPCH_Ec/Ior1 is set at the level corresponding to 5% TPC error rate.			
Note 2: The uplink power control from cell1 shall be such that the UE transmit power would stay at -15 dBm.			
Note 3: The maximum DPCH_Ec/Ior1 level in cell1 is -9 dB.			

Table 7.7.3.2: Test requirements for reliable TPC command combining

Parameter	Unit	Test 1	Test 2
UE output power	dBm	-15 ± 5 dB	-15 ± 3 dB

The reference for this requirement is TS 25.101 [1] clause 8.7.3.1.

7.7.3.3 Test purpose

To verify that the combining of reliable TPC commands received in soft handover results in TPC_cmd being derived so as to meet the requirements stated in tables 7.7.3.2 and 7.7.3.3.

7.7.3.4 Method of test

7.7.3.4.1 Test 1 Initial conditions

Test environment: normal; see clauses G.2.1 and G.2.2.

Frequencies to be tested: mid range; see clause G.2.4.

- 1) Connect three SS's to the UE antenna connector as shown in figure A.18.
- 2) Activate Cell 1.

7.7.3.4.2 Test 1 Procedures

- 1) Set up a call according to the Generic Call Setup procedure TS34.108 [3] sub clause 7.3.2. Signal the uplink DPCH power control parameters to use Algorithm 1 and a step size of 1dB. Enter the UE into loopback test mode and start the loopback test.
- 2) Activate the other two cells (Cell 2 and Cell 3) on the other SS's.
- 3) Set the test parameters as specified in table 7.7.3.3 for Test 1.
- 4) The downlink DPCH Ec/Ior1 level is adjusted so that 5 +/-1%. downlink TPC error is maintained from Ec/Ior1. Cell 1 transmits a known pattern of TPC commands and for each slot detect the power step. Thereby the TPC error rate can be measured. The downlink DPCH Ec/Ior1 is adjusted so that the TPC error rate is equal to 5 +/-1%.
- 5) Send power control commands to the UE until the UE output power measured by Test System is adjusted to the specified power level with ±1.5 dB tolerance due to power control step size.
- 6) Set up the UE in soft handover between Cell 1, Cell 2 and Cell 3. The downlink TPC commands from Cell 2 and Cell 3 shall continuously have the value "1" during the test while Cell 1 use the UE Output power = -15 dBm as the power control target.
- 7) The DPCH Ec/Ior2 and DPCH Ec/Ior3 are adjusted to be 10 dB lower than DPCH_Ec/Ior1.
- 8) Measure the mean output power of the UE, not including the 25 µs transient periods at the start and end of each slot.
- 9) Repeat step 8) according to Annex F.6.2 Table F.6.2.8.
- 10) End test 1 and disconnect UE.

See TS 34.108 [3] and TS 34.109 [4] for details regarding the generic call setup procedure and loopback test.

7.7.3.4.3 Test 2 Initial conditions

Test environment: normal; see clauses G.2.1 and G.2.2.

Frequencies to be tested: mid range; see clause G.2.4.

- 1) Connect two SS's to the UE antenna connector as shown in figure A.13.
- 2) Activate Cell 1.

7.7.3.4.4 Test 2 Procedures

- 1) Set up a call according to the Generic Call Setup procedure TS34.108 [3] sub clause 7.3.2. Signal the uplink DPCH power control parameters to use Algorithm 1 and a step size of 1dB. Enter the UE into loopback test mode and start the loopback test.
- 2) Activate the other cell (Cell 2) on the other SS
- 3) Set the test parameters as specified in table 7.7.3.3 for Test 2.
- 4) The downlink DPCH Ec/Ior1 level is adjusted so that 5 +/-1%. downlink TPC error is maintained from Ec/Ior1. Cell 1 transmits a known pattern of TPC commands and for each slot detect the power step. Thereby the TPC error rate can be measured. The downlink DPCH Ec/Ior1 is adjusted so that the TPC error rate is equal to 5 +/-1%.
- 5) Send power control commands to the UE until the UE output power measured by Test System is adjusted to the specified power level with ±1.5 dB tolerance due to power control step size.
- 6) Set up the UE in soft handover between Cell 1 and Cell 2. The downlink TPC commands from Cell 2 shall continuously have the value "1" during the test while Cell 1 use the UE Output power = -15 dBm as the power control target.
- 7) The DPCH Ec/Ior2 is adjusted to be 6 dB higher than DPCH_Ec/Ior1.
- 8) Measure the mean output power of the UE, not including the 25 µs transient periods at the start and end of each slot.
- 9) Repeat step 8) according to Annex F.6.2 Table F.6.2.8.
- 10) End test 2 and disconnect UE.

See TS 34.108 [3] and TS 34.109 [4] for details regarding the generic call setup procedure and loopback test.

7.7.3.5 Test requirements

Test parameters are specified in Table 7.7.3.3. Before the start of the tests, the UE transmit power shall be initialised to -15 dBm. An actual UE transmit power may vary from the target level of -15 dBm due to inaccurate UE output power step.

Table 7.7.3.3: Parameters for reliable TPC command combining

Parameter	Unit	Test 1	Test 2
Phase reference	-	P-CPICH	
DPCH_Ec/Ior1	dB	Note 1	Note 1 & Note 3
DPCH_Ec/Ior2	dB	DPCH_Ec/Ior1 - 10	DPCH_Ec/Ior1 + 6
DPCH_Ec/Ior3	dB	DPCH_Ec/Ior1 - 10	-
\hat{I}_{or1}/I_{oc}	dB	-1	-1
\hat{I}_{or2}/I_{oc}	dB	-1	-1
\hat{I}_{or3}/I_{oc}	dB	-1	-
I_{oc}	dBm/3.84 MHz	-60	
Power-Control-Algorithm	-	Algorithm 1	
Cell 1 TPC commands	-	Note 2	Note 2
Cell 2 TPC commands	-	"1"	"1"
Cell 3 TPC commands	-	"1"	-
Information data Rate	Kbps	12.2	
Propagation condition	-	Static	
Note 1:	The DPCH_Ec/Ior1 is configured to a level such that the TPC error rate is set to 5+/-1% (with 95% confidence).		
Note 2:	The uplink power control from cell1 shall be such that the UE transmit power would stay at -15 dBm.		
Note 3:	The maximum DPCH_Ec/Ior1 level in cell1 is -9 dB.		

NOTE 1: If the above Test Requirement differs from the Minimum Requirement then the Test Tolerance applied for this test is non-zero. The Test Tolerance for this test is defined in clause F.2 and the explanation of how the Minimum Requirement has been relaxed by the Test Tolerance is given in clause F.4.

- 1) In step 8) of clause 7.7.3.4.2, the UE transmit power samples, which are defined as the mean power over one timeslot, shall stay 90% of the time within the range defined in Table 7.7.3.2.
- 2) In step 8) of clause 7.7.3.4.4, the UE transmit power samples, which are defined as the mean power over one timeslot, shall stay 90% of the time within the range defined in Table 7.7.3.2.

7.8 Power control in downlink

Power control in the downlink is the ability of the UE receiver to converge to required link quality set by the network while using as low power as possible in downlink. If a BLER target has been assigned to a DCCH (See clause C.3), then it has to be such that outer loop is based on DTCH and not on DCCH.

Note: The above implies that the BLER target for the DCCH should be set low enough so that it does not dominate the one for the DTCH.

The minimum requirements in this subclause were derived with the assumption that the UTRAN responds immediately to the uplink TPC commands by adjusting the power of the first pilot field of the DL DPCCH that commences after end of the received TPC command.

However, for downlink power control tests introduced to the specifications in Release 99, Release 4 and Release 5, (and for those same tests that exist unmodified in Release 6 and later releases), it is permitted to use an SS implementation which has an additional one slot delay in responding to TPC commands. In such cases, there are two sets of test requirements and the choice of which set to use is a function only of the implementation of the SS and not a function of the UE.

Note: The additional delay in TPC response time shifts the expected UE performance. Simulations have predicted the expected change and rather than provide two alternative minimum requirements, for convenience the change in expected performance is covered by altering the test tolerance. This change in test tolerance does not imply the alternative implementation is less accurate.

Note: The possibility of removing the alternative test method for release 7 and later is for further study. If an SS implementation is upgraded to use the immediate TPC response time it will be necessary to modify the test implementation to use the applicable test requirements.

7.8.1 Power control in the downlink, constant BLER target

7.8.1.1 Definition and applicability

Power control in the downlink is the ability of the UE receiver to converge to required link quality set by the network while using as low power as possible in downlink. If a BLER target has been assigned to a DCCH (See clause C.3), then it has to be such that outer loop is based on DTCH and not on DCCH. The requirements and this test apply to all types of UTRA for the FDD UE.

7.8.1.2 Minimum requirements

For the parameters specified in table 7.8.1.1 the downlink $\frac{DPCH_E_c}{I_{or}}$ power ratio measured values, which are averaged over one slot, shall be below the specified value in table 7.8.1.2 more than 90% of the time. BLER shall be as shown in table 7.8.1.2. Power control in downlink is ON during the test.

Table 7.8.1.1: Test parameter for downlink power control, constant BLER target

Parameter	Test 1	Test 2	Unit
\hat{I}_{or}/I_{oc}	9	-1	dB
I_{oc}	-60		dBm / 3,84 MHz
Information Data Rate	12,2		kbps
Target quality on DTCH	0,01		BLER
Propagation condition	Case 4		
Maximum_DL_Power (note)	7		dB
Minimum_DL_Power (note)	-18		dB
DL Power Control step size, Δ_{TPC}	1		dB
Limited Power Increase	"Not used"		-
NOTE: Power is compared to P-CPICH as specified in [9].			

Table 7.8.1.2: Requirements in downlink power control, constant BLER target

Parameter	Test 1	Test 2	Unit
$\frac{DPCH_E_c}{I_{or}}$	-16,0	-9,0	dB
Measured quality on DTCH	0,01 ± 30 %	0,01 ± 30 %	BLER

The reference for this requirement is TS 25.101 [1] clause 8.8.1.1.

7.8.1.3 Test purpose

To verify that the UE receiver is capable of converging to required link quality set by network while using as low power as possible.

7.8.1.4 Method of test

7.8.1.4.1 Initial conditions

Test environment: normal; see clauses G.2.1 and G.2.2.

Frequencies to be tested: mid range; see clause G.2.4.

- 1) Connect SS, multipath fading simulator and an AWGN source to the UE antenna connector as shown in figure A.10.
- 2) Set up a call according to the Generic call setup procedure specified in TS 34.108 [3] clause 7.3.2, with the exception of the information element of the RRC CONNECTION SETUP message listed in Annex I. With this exception, the outer loop is based on DTCH and not on DCCH.
- 3) RF parameters are set up according to table 7.8.1.3.
- 4) Enter the UE into loopback test mode and start the loopback test.
- 5) SS will vary the physical channel power in downlink according to the TPC commands from UE. Downlink power control mode (DPC_MODE) 0 shall be used.

See TS 34.108 [3] and TS 34.109 [4] for details regarding generic call setup procedure and loopback test.

7.8.1.4.2 Procedure

- 1) After call set up, the SS waits 15 seconds.

- 2) After this period, BLER is measured. Simultaneously the downlink $\frac{DPCH - E_c}{I_{or}}$ power ratio averaged over one slot is measured.

7.8.1.5 Test Requirements

The test parameters are specified in table 7.8.1.3.

Table 7.8.1.3: Test parameter for downlink power control, constant BLER target

Parameter	Test 1	Test 2	Unit
\hat{I}_{or}/I_{oc}	9,6	-0,4	dB
I_{oc}	-60		dBm / 3,84 MHz
Information Data Rate	12,2		kbps
Target quality on DTCH	0,01		BLER
Propagation condition	Case 4		
Maximum_DL_Power (note)	7		dB
Minimum_DL_Power (note)	-18		dB
DL Power Control step size, Δ_{TPC}	1		dB
Limited Power Increase	"Not used"		-
NOTE: Power is compared to P-CPICH as specified in [9].			

- a) The measured quality on DTCH does not exceed the values in table 7.8.1.4 for SS supporting immediate TPC response time or the values in 7.8.1.4A for SS supporting an additional one slot delay in TPC response time. BLER measurements shall be performed according to the statistical testing in Annex F.6.1.10.
- b) The downlink $\frac{DPCH - E_c}{I_{or}}$ power ratio values, which are averaged over one slot, shall be below the values in table 7.8.1.4 more than 90 % of the time for SS supporting immediate TPC response time or the values in 7.8.1.4A for SS supporting an additional one slot delay in TPC response time.

Table 7.8.1.4: Requirements in downlink power control, constant BLER target

Parameter	Test 1	Test 2	Unit
$\frac{DPCH - E_c}{I_{or}}$	-15,9	-8,9	dB
Measured quality on DTCH	0,01 ± 30 %	0,01 ± 30 %	BLER

Table 7.8.1.4A: Requirements in downlink power control, constant BLER target using SS with an additional one slot delay in power control response time

Parameter	Test 1	Test 2	Unit
$\frac{DPCH - E_c}{I_{or}}$	-15,6	-8,7	dB
Measured quality on DTCH	0,01 ± 30 %	0,01 ± 30 %	BLER

NOTE: If the above Test Requirement differs from the Minimum Requirement then the Test Tolerance applied for this test is non-zero. The Test Tolerance for this test is defined in clause F.2 and the explanation of how the Minimum Requirement has been relaxed by the Test Tolerance is given in clause F.4.

7.8.2 Power control in the downlink, initial convergence

7.8.2.1 Definition and applicability

This requirement verifies that DL power control works properly during the first seconds after DPCH connection is established. The requirements and this test apply to all types of UTRA for the FDD UE.

7.8.2.2 Minimum requirements

For the parameters specified in table 7.8.2.1 the downlink DPCH_Ec/Ior power ratio measured values, which are averaged over 50 ms, shall be within the range specified in table 7.8.2.2 more than 90 % of the time. T1 equals to 500 ms and it starts 10 ms after the uplink DPDCH physical channel is considered established. T2 equals to 500 ms and it starts when T1 has expired. Power control is ON during the test.

The first 10 ms shall not be used for averaging, i.e. the first sample to be input to the averaging filter is at the beginning of T1. The averaging shall be performed with a sliding rectangular window averaging filter. The window size of the averaging filter is linearly increased from 0 up to 50 ms during the first 50 ms of T1, and then kept equal to 50ms.

Table 7.8.2.1: Test parameters for downlink power control, initial convergence

Parameter	Test 1	Test 2	Test 3	Test 4	Unit
Target quality value on DTCH	0,01	0,01	0,1	0,1	BLER
Initial DPCH_Ec/Ior	-5,9	-25,9	-3	-22,8	dB
Information Data Rate	12,2	12,2	64	64	kbps
\hat{I}_{or}/I_{oc}	-1				dB
I_{oc}	-60				dBm/3,84 MHz
Propagation condition	Static				
Maximum_DL_Power (note)	7				dB
Minimum_DL_Power (note)	-18				dB
DL Power Control step size, Δ_{TPC}	1				dB
Limited Power Increase	"Not used"				
NOTE: Power is compared to P-CPICH as specified in [9].					

Table 7.8.2.2: Requirements in downlink power control, initial convergence

Parameter	Test 1 and Test 2	Test 3 and Test 4	Unit
$\frac{DPCH_E_c}{I_{or}}$ during T1	$-18,9 \leq DPCH_E_c/I_{or} \leq -11,9$	$-15,1 \leq DPCH_E_c/I_{or} \leq -8,1$	dB
$\frac{DPCH_E_c}{I_{or}}$ during T2	$-18,9 \leq DPCH_E_c/I_{or} \leq -14,9$	$-15,1 \leq DPCH_E_c/I_{or} \leq -11,1$	dB

Note: The low limit is decreased by 3 dB for a UE with more than one antenna connector.

The reference for this requirement is TS 25.101 [1] clause 8.8.2.1.

Note: DTCH shall be transmitted during the whole test.

7.8.2.3 Test purpose

To verify that DL power control works properly during the first seconds after DPCH connection is established.

7.8.2.4 Method of test

7.8.2.4.1 Initial conditions

Test environment: normal; see clauses G.2.1 and G.2.2.

Frequencies to be tested: mid range; see clause G.2.4.

- 1) Connect SS and an AWGN source to the UE antenna connector as shown in figure A.9.

7.8.2.4.2 Procedure

- 1) Enter the UE into loopback test mode according to the Generic call setup procedure specified in TS 34.108 [3] clause 7.3.2, with the exception of the information element of the RRC CONNECTION SETUP message listed in Annex I. With this exception, the outer loop is based on DTCH and not on DCCH. System simulator shall activate power control at the activation time of the Radio Bearer Setup message (At RRC connection setup only)

DCCH is established). The uplink DPCH physical channel is considered established at the activation time of the Radio Bearer Setup message.

- 2) RF parameters are set up according to table 7.8.2.3 for the test running. After the transmission of Radio Bearer Setup message, Initial DPCH_Ec/Ior is set to the specified level at the activation time.
- 3) SS will vary the physical channel power in downlink according to the TPC commands from UE. Downlink power control mode (DPC_MODE) 0 shall be used.
- 4) Measure $\frac{DPCH_E_c}{I_{or}}$ power ratio averaged over 50 ms during T1. T1 starts 10 ms after the uplink DPDCH physical channel is considered established and T1 equals to 500 ms. The first 10 ms shall not be used for averaging, i.e. the first sample to be input to the averaging filter is at the beginning of T1. The averaging shall be performed with a sliding rectangular window averaging filter. The window size of the averaging filter is linearly increased from 0 up to 50 ms during the first 50 ms of T1, and then kept equal to 50ms. At the first slot where the averaging window crosses the T1 - T2 boundary, the average power level within the window begins to test against the T2 requirements.
- 5) Measure $\frac{DPCH_E_c}{I_{or}}$ power ratio averaged over 50 ms during T2. T2 starts, when T1 has expired and T2 equals to 500 ms.

The reception of the "RB setup complete" and the "CLOSE UE TEST LOOP COMPLETE" messages is not necessary to pass this test.

7.8.2.5 Test Requirements

The test parameters are specified in table 7.8.2.3.

Table 7.8.2.3: Test parameters for downlink power control, initial convergence

Parameter	Test 1	Test 2	Test 3	Test 4	Unit
Target quality value on DTCH	0,01	0,01	0,1	0,1	BLER
Initial DPCH_Ec/Ior	-5,9	-25,9	-3	-22,8	dB
Down Link Information Data Rate	12,2	12,2	64	64	kbps
Up Link Information Data Rate	12,2 Note 2	12,2 Note 2	12,2 Note 3	12,2 Note 3	kbps
\hat{I}_{or}/I_{oc}	-1				dB
I_{oc}	-60				dBm/3,84 MHz
Propagation condition	Static				
Maximum_DL_Power (note 1)	7				dB
Minimum_DL_Power (note 1)	-18				dB
DL Power Control step size, Δ_{TPC}	1				dB
Limited Power Increase	"Not used"				
NOTE 1: Power is compared to P-CPICH as specified in [9].					
NOTE 2: UL TM AUXMC 12.2 kbps, no CRC. See C.6.3.					
NOTE 3: UL AM AUXMC 12.2 kbps. See C.6.7.					

- a) The downlink $\frac{DPCH_E_c}{I_{or}}$ power ratio values shall be within the range specified in table 7.8.2.4 during T1 more than 90 % of the time or, when using an SS with an additional one slot delay in power control response, within the range specified in table 7.8.2.4A during T1 more than 90 % of the time.
- b) The downlink $\frac{DPCH_E_c}{I_{or}}$ power ratio values shall be within the range specified in table 7.8.2.4 during T2 more than 90 % of the time or, when using an SS with an additional one slot delay in power control response, within the range specified in table 7.8.2.4A during T2 more than 90 % of the time.

Table 7.8.2.4: Requirements in downlink power control, initial convergence

Parameter	Test 1 and Test 2	Test 3 and Test 4	Unit
$\frac{DPCH_E_c}{I_{or}}$ during T1	$-19,5 \leq DPCH_Ec/lor \leq -11,3$	$-15,7 \leq DPCH_Ec/lor \leq -7,5$	dB
$\frac{DPCH_E_c}{I_{or}}$ during T2	$-19,5 \leq DPCH_Ec/lor \leq -14,3$	$-15,7 \leq DPCH_Ec/lor \leq -10,5$	dB

Note: The low limit is decreased by 3 dB for a UE with more than one antenna connector.

Table 7.8.2.4A: Requirements in downlink power control, initial convergence target using SS with an additional one slot delay in power control response time

Parameter	Test 1 and Test 2	Test 3 and Test 4	Unit
$\frac{DPCH_E_c}{I_{or}}$ during T1	$-19,7 \leq DPCH_Ec/lor \leq -11,1$	$-15,9 \leq DPCH_Ec/lor \leq -7,3$	dB
$\frac{DPCH_E_c}{I_{or}}$ during T2	$-19,7 \leq DPCH_Ec/lor \leq -14,1$	$-15,9 \leq DPCH_Ec/lor \leq -10,3$	dB

Note: The low limit is decreased by 3 dB for a UE with more than one antenna connector.

NOTE: If the above Test Requirement differs from the Minimum Requirement then the Test Tolerance applied for this test is non-zero. The Test Tolerance for this test is defined in clause F.2 and the explanation of how the Minimum Requirement has been relaxed by the Test Tolerance is given in clause F.4.

7.8.3 Power control in the downlink, wind up effects

7.8.3.1 Definition and applicability

This requirement verifies that, after the downlink maximum power is limited in the UTRAN and it has been released again, the downlink power control in the UE does not have a wind up effect, i.e. the required DL power has increased during time period the DL power was limited. The requirements and this test apply to all types of UTRA for the FDD UE.

7.8.3.2 Minimum requirements

This test is run in three stages where stage 1 is for convergence of the power control loop, in stage two the maximum downlink power for the dedicated channel is limited not to be higher than the parameter specified in table 7.8.3.1. All parameters used in the three stages are specified in table 7.8.3.1. The downlink $\frac{DPCH_E_c}{I_{or}}$ power ratio measured values, which are averaged over one slot, during stage 3 shall be lower than the value specified in table 7.8.3.2 more than 90 % of the time. Power control of the UE is ON during the test.

Table 7.8.3.1: Test parameter for downlink power control, wind-up effects

Parameter	Test 1			Unit
	Stage 1	Stage 2	Stage 3	
Time in each stage	>15	5	0,5	s
\hat{I}_{or}/I_{oc}	5			dB
I_{oc}	-60			dBm/3,84 MHz
Information Data Rate	12,2			kbps
Quality target on DTCH	0,01			BLER
Propagation condition	Case 4			
Maximum_DL_Power (note)	7	-6,2	7	dB
Minimum_DL_Power (note)	-18			dB
DL Power Control step size, ΔTPC	1			dB
Limited Power Increase	"Not used"			-
NOTE: Power is compared to P-CPICH as specified in [9].				

Table 7.8.3.2: Requirements in downlink power control, wind-up effects

Parameter	Test 1, stage 3	Unit
$\frac{DPCH_E_c}{I_{or}}$	-13,3	dB

The reference for this requirement is TS 25.101 [1] clause 8.8.3.1.

7.8.3.3 Test purpose

To verify that the UE downlink power control does not require too high downlink power during a period after the downlink power is limited by the UTRAN.

7.8.3.4 Method of test

7.8.3.4.1 Initial conditions

Test environment: normal; see clauses G.2.1 and G.2.2.

Frequencies to be tested: mid range; see clause G.2.4.

- 1) Connect SS, multipath fading simulator and an AWGN source to the UE antenna connector as shown in figure A.10.
- 2) Set up a call according to the Generic call setup procedure specified in TS 34.108 [3] clause 7.3.2, with the exception of the information element of the RRC CONNECTION SETUP message listed in Annex I. With this exception, the outer loop is based on DTCH and not on DCCH.
- 3) Enter the UE into loopback test mode and start the loopback test.

See TS 34.108 [3] and TS 34.109 [4] for details regarding generic call setup procedure and loopback test.

7.8.3.4.2 Procedure

- 1) RF parameters are set up according to table 7.8.3.3. Stage 1 is used for the power control to converge and during Stage 2 the maximum downlink power is limited by UTRAN.
- 2) SS will vary the physical channel power in downlink according to the TPC commands from UE during stages 1, 2, and 3. Downlink power control mode (DPC_MODE) 0 shall be used.
- 3) Measure $\frac{DPCH_E_c}{I_{or}}$ power ratio during stage 3 according to table 7.8.3.3.
- 4) Repeat steps 1 – 3 328 times.

Note: The number of repetitions (328) is derived from minimum testing time for 3 km/h fading channels (Table F.6.1.6.2; 164 seconds).

7.8.3.5 Test Requirements

The test parameters are specified in table 7.8.3.3.

Table 7.8.3.3: Test parameter for downlink power control, wind-up effects

Parameter	Test 1			Unit
	Stage 1	Stage 2	Stage 3	
Time in each stage	>15	5	0,5	s
\hat{I}_{or}/I_{oc}	5,6			dB
I_{oc}	-60			dBm/3,84 MHz
Information Data Rate	12,2			kbps
Quality target on DTCH	0,01			BLER
Propagation condition	Case 4			
Maximum_DL_Power (note)	7	-6,2	7	dB
Minimum_DL_Power (note)	-18			dB
DL Power Control step size, Δ_{TPC}	1			dB
Limited Power Increase	"Not used"			-

NOTE: Power is compared to P-CPICH as specified in [9].

The downlink $\frac{DPCH_E_c}{I_{or}}$ power ratio values, which are averaged over one slot during stage 3, shall be lower than the level specified in table 7.8.3.4 during stage 3 more than 90 % of the time for SS supporting immediate TPC response time or the values in 7.8.3.4A for SS supporting an additional one slot delay in TPC response time.

Table 7.8.3.4: Requirements in downlink power control, wind-up effects

Parameter	Test 1, stage 3	Unit
$\frac{DPCH_E_c}{I_{or}}$	-13,2	dB

Table 7.8.3.4A: Requirements in downlink power control, wind-up effects with an additional one slot delay in power control response time

Parameter	Test 1, stage 3	Unit
$\frac{DPCH_E_c}{I_{or}}$	-12.9	dB

NOTE: If the above Test Requirement differs from the Minimum Requirement then the Test Tolerance applied for this test is non-zero. The Test Tolerance for this test is defined in clause F.2 and the explanation of how the Minimum Requirement has been relaxed by the Test Tolerance is given in clause F.4.

7.8.4 Power control in the downlink, different transport formats

7.8.4.1 Definition and applicability

This requirement verifies that UE outer loop power control has proper behaviour with different transport formats. The requirements and this test apply for Release 5 and later releases to all types of UTRA for the FDD UE.

7.8.4.2 Minimum requirements

Test 1 verifies that UE outer loop power control has proper behaviour with different transport formats.

The downlink reference measurement channel used in this subclause shall have two different transport formats. The different transport formats of the downlink reference measurement channel used shall correspond to the measurement channels specified in Annex C.3.1A. The different transport formats of the uplink reference measurement channel used shall correspond to the measurement channels specified in Annex C.6.3A. The transport format used in downlink reference measurement channel during different stages of the test shall be set according to the information data rates specified in Table 7.8.4.1. During stage 1 a downlink transport format combination using the 12.2kbps information data rate DTCH shall be used, and during stage 2 the downlink transport format combination shall be changed such that a 0kbps information data rate transport format combination is then used.

For the parameters specified in Table 7.8.4.1 the downlink $\frac{DPCH - E_c}{I_{or}}$ power ratio measured values, which are averaged over one slot, shall be below the specified value in Table 7.8.4.2 more than 90% of the time. BLER shall be as shown in Table 7.8.4.2. Power control in downlink is ON during the test.

Table 7.8.4.1: Parameters for downlink power control in case of different transport formats

Parameter	Unit	Test 1	
		Stage 1	Stage 2
Time in each stage	S	Note 1	Note 1
\hat{I}_{or}/I_{oc}	dB	9	
I_{oc}	dBm/3.84 MHz	-60	
Information Data Rate	Kbps	12.2	0
Quality target on DTCH	BLER	0.01	
Quality target on DCCH	BLER	1	
Propagation condition		Case4	
Maximum_DL_Power	dB	7	
Minimum_DL_Power	dB	-18	
DL Power Control step size, Δ_{TPC}	dB	1	
Limited Power Increase	-	"Not used"	
Note 1: The stage lasts until the DTCH quality has converged to the quality target			

NOTE: Power is compared to P-CPICH as specified in [9].

Table 7.8.4.2: Requirements in downlink power control in case of different transport formats

Parameter	Unit	Test 1, stage 1	Test 1, stage 2
$\frac{DPCH - E_c}{I_{or}}$	dB	-16.0	-18.0
Measured quality on DTCH	BLER	0.01±30%	0.01±30%

The reference for this requirement is TS 25.101 [1] clause 8.8.4.1.

7.8.4.3 Test purpose

To verify that the UE outer loop power control works properly with different transport formats.

7.8.4.4 Method of test

7.8.4.4.1 Initial conditions

Test environment: normal; see clauses G.2.1 and G.2.2.

Frequencies to be tested: mid range; see clause G.2.4.

- 1) Connect SS, multipath fading simulator and an AWGN source to the UE antenna connector as shown in figure A.10.
- 2) Set up a call according to the Generic call setup procedure specified in TS 34.108 [3] clause 7.3.2, with the exception of the information elements of the RRC CONNECTION SETUP message listed in Annex I. With this exception, the outer loop is based on DTCH and not on DCCH. Downlink power control mode (DPC_MODE) 0 shall be used.

3) Enter the UE into loopback test mode 2 and start the loopback test.

See TS 34.108 [3] and TS 34.109 [4] for details regarding generic call setup procedure and loopback test.

7.8.4.4.2 Procedure

- 1) RF parameters are set up according to table 7.8.4.3.
- 2) SS will vary the physical channel power in downlink according to the TPC commands from UE during stage 1 and 2.
- 3) Stage 1. The SS waits 15 seconds before it performs the measurement in step 4.
- 4) Measure quality on DTCH according to statistical significance in Annex F.6.1.10 and $\frac{DPCH - E_c}{I_{or}}$ power ratio according to table 7.8.4.3.
- 5) Stage 2. The SS waits 15 seconds before it performs the measurement in step 6.
- 6) Measure quality on DTCH according to statistical significance in Annex F.6.1.10 and $\frac{DPCH - E_c}{I_{or}}$ power ratio according to table 7.8.4.3. Note: The measurement should not start until after power control has converged.

7.8.4.5 Test Requirements

The test parameters are specified in table 7.8.4.3.

Table 7.8.4.3: Parameters for downlink power control in case of different transport formats

Parameter	Unit	Test 1	
		Stage 1	Stage 2
Time in each stage	S	Note 1	Note 1
\hat{I}_{or}/I_{oc}	dB	9.6	
I_{oc}	dBm/3.84 MHz	-60	
Information Data Rate	Kbps	12.2	0
Quality target on DTCH	BLER	0.01	
Quality target on DCCH	BLER	1	
Propagation condition		Case4	
Maximum_DL_Power	dB	7	
Minimum_DL_Power	dB	-18	
DL Power Control step size, Δ_{TPC}	dB	1	
Limited Power Increase	-	"Not used"	
Note 1: The stage lasts until the DTCH quality has converged to the quality target.			

NOTE: Power is compared to P-CPICH as specified in [9].

- a) The measured quality on DTCH does not exceed the values in table 7.8.4.4 or in table 7.8.4.5.
- b) The downlink $\frac{DPCH - E_c}{I_{or}}$ power ratio values, which are averaged over one slot, shall be below the values in table 7.8.4.4 more than 90 % of the time for SS supporting immediate power control response time or below the values in 7.8.4.5 for SS supporting an additional one slot delay in power control response time.

Table 7.8.4.4: Requirements in downlink power control in case of different transport formats

Parameter	Unit	Test 1, stage 1	Test 1, stage 2
$\frac{DPCH_E_c}{I_{or}}$	dB	-15.9	-17.9
Measured quality on DTCH	BLER	0.01±30%	0.01±30%

Table 7.8.4.5: Requirements in downlink power control in case of different transport formats with an additional one slot delay in power control response time

Parameter	Unit	Test 1, stage 1	Test 1, stage 2
$\frac{DPCH_E_c}{I_{or}}$	dB	-15.6	-17.7
Measured quality on DTCH	BLER	0.01±30%	0.01±30%

NOTE: If the above Test Requirement differs from the Minimum Requirement then the Test Tolerance applied for this test is non-zero. The Test Tolerance for this test is defined in clause F.2 and the explanation of how the Minimum Requirement has been relaxed by the Test Tolerance is given in clause F.4.

7.9 Downlink compressed mode

Downlink compressed mode is used to create gaps in the downlink transmission, to allow the UE to make measurements on other frequencies.

7.9.1 Single link performance

7.9.1.1 Definition and applicability

The receiver single link performance of the Dedicated Traffic Channel (DCH) in compressed mode is determined by the Block Error Ratio (BLER) and transmitted $DPCH_E_c/I_{or}$ power ratio in the downlink. If a BLER target has been assigned to a DCCH (See clause C.3), then it has to be such that outer loop is based on DTCH and not on DCCH.

Note: The above implies that the BLER target for the DCCH should be set low enough so that it does not dominate the one for the DTCH.

The compressed mode parameters are given in clause C.5. Tests 1 and 2 are using Set 1 compressed mode pattern parameters from table C.5.1 in clause C.5 while tests 3 and 4 are using Set 2 compressed mode patterns from the same table.

The requirements for compressed mode by spreading factor reduction (tests 1 and 2) apply to all types of UTRA for the FDD UE from Release 99 onwards. The requirements for compressed mode by puncturing (tests 3 and 4) apply to all types of UTRA for the FDD UE for Release 99 and Release 4 only..

7.9.1.2 Minimum requirements

For the parameters specified in table 7.9.1 the downlink $\frac{DPCH_E_c}{I_{or}}$ power ratio measured values, which are averaged over one slot, shall be below the specified value in table 7.9.2 more than 90% of the time. The measured quality on DTCH shall be as required in table 7.9.2.

Downlink power control is ON during the test. Uplink TPC commands shall be error free.

Table 7.9.1: Test parameter for downlink compressed mode

Parameter	Test 1	Test 2	Test 3	Test 4	Unit
Delta SIR1	0	3	0	3	dB
Delta SIR after1	0	3	0	3	dB
Delta SIR2	0	0	0	0	dB
Delta SIR after2	0	0	0	0	dB
\hat{I}_{or}/I_{oc}		9			dB
I_{oc}		-60			dBm / 3,84 MHz
Information Data Rate		12,2			kbps
Propagation condition		Case 2			
Target quality value on DTCH		0,01			BLER
Maximum DL Power (note)		7			dB
Minimum DL Power (note)		-18			dB
DL Power Control step size, Δ_{TPC}		1			dB
Limited Power Increase		"Not used"			-

NOTE: Power is compared to P-CPICH as specified in [9].

Table 7.9.2: Requirements in downlink compressed mode

Parameter	Test 1	Test 2	Test 3	Test 4	Unit
$\frac{DPCH - E_c}{I_{or}}$	-14,6	No requirements	-15,2	No requirements	dB
Measured quality of compressed and recovery frames	No requirements	< 0,001	No requirements	< 0,001	BLER
Measured quality on DTCH	0,01 ± 30 %				BLER

The reference for this requirement is TS 25.101 [1] clause 8.9.1.1.

7.9.1.3 Test purpose

The purpose of this test is to verify the reception of DPCH in a UE while downlink is in a compressed mode. The UE needs to preserve the BLER using sufficient low DL power. It is also verified that UE applies the Delta SIR values, which are signaled from network, in its outer loop power control algorithm.

7.9.1.4 Method of test

7.9.1.4.1 Initial conditions

Test environment: normal; see clauses G.2.1 and G.2.2.

Frequencies to be tested: mid range; see clause G.2.4.

- 1) Connect SS, multipath fading simulator and an AWGN source to the UE antenna connector as shown in figure A.10.
- 2) Set up a call according to the Generic call setup procedure, specified in TS 34.108 [3] clause 7.3.2, with the exception of the information element of the RRC CONNECTION SETUP message listed in Annex I. With this exception, the outer loop is based on DTCH and not on DCCH..
- 3) RF parameters are set up according to table 7.9.3.
- 4) Set compressed mode parameters according to table C.5.1. Tests 1 and 2 are using Set 1 compressed mode pattern parameters and while tests 3 and 4 are using Set 2 compressed mode pattern parameters.

NOTE: Set 2 is applicable to Release 99 and Release 4 only.

- 5) Enter the UE into loopback test mode and start the loopback test.
- 6) SS will vary the physical channel power in downlink according to the TPC commands from UE. Downlink power control mode (DPC_MODE) 0 shall be used. SS response time for UE TPC commands shall be one slot.

7) The SS waits 15 seconds before it performs measurements as described in 7.9.1.4.2.

See TS 34.108 [3] and TS 34.109 [4] for details regarding generic call setup procedure and loopback test.

7.9.1.4.2 Procedure

- 1) Test 1: Measure quality on DTCH and $\frac{DPCH - E_c}{I_{or}}$ power ratio values averaged over one slot.
- 2) Test 2: Measure quality on DTCH and quality of compressed and recovery frames.
- 3) Test 3: Measure quality on DTCH and $\frac{DPCH - E_c}{I_{or}}$ power ratio values averaged over one slot.
- 4) Test 4: Measure quality on DTCH and quality of compressed and recovery frames.

7.9.1.5 Test requirements

The test parameters are specified in table 7.9.3.

Table 7.9.3: Test parameter for downlink compressed mode

Parameter	Test 1	Test 2	Test 3	Test 4	Unit
Delta SIR1	0	3	0	3	dB
Delta SIR after1	0	3	0	3	dB
Delta SIR2	0	0	0	0	dB
Delta SIR after2	0	0	0	0	dB
\hat{I}_{or}/I_{oc}		9,6			dB
I_{oc}		-60			dBm / 3,84 MHz
Information Data Rate		12,2			kbps
Propagation condition		Case 2			
Target quality value on DTCH		0,01			BLER
Maximum DL Power (note)		7			dB
Minimum DL Power (note)		-18			dB
DL Power Control step size, Δ_{TPC}		1			dB
Limited Power Increase		"Not used"			-

NOTE: Power is compared to P-CPICH as specified in [9].

- a) Test 1: The downlink $\frac{DPCH - E_c}{I_{or}}$ power ratio values averaged over one slot shall be below the values in table 7.9.4 more than 90 % of the time. The measured quality on DTCH shall be as required in table 7.9.4. BLER measurements based on measured quality on DTCH shall be performed according to the statistical testing in Annex F.6.1.10.
- b) Test 2: Measured quality on DTCH and measured quality of compressed and recovery frames do not exceed the values in table 7.9.4. BLER measurements based on measured quality on DTCH shall be performed according to the statistical testing in Annex F.6.1.10.
- c) Test3: The downlink $\frac{DPCH - E_c}{I_{or}}$ power ratio values averaged over one slot shall be below the values in table 7.9.2 more than 90 % of the time. The measured quality on DTCH shall be as required in table 7.9.4. BLER measurements based on measured quality on DTCH shall be performed according to the statistical testing in Annex F.6.1.10.
- d) Test 4: Measured quality on DTCH and measured quality of compressed and recovery frames do not exceed the values in table 7.9.4. BLER measurements based on measured quality on DTCH shall be performed according to the statistical testing in Annex F.6.1.10.

Table 7.9.4: Requirements in downlink compressed mode

Parameter	Test 1	Test 2	Test 3	Test 4	Unit
$\frac{DPCH_E_c}{I_{or}}$	-14,5	No requirements	-15,1	No requirements	dB
Measured quality of compressed and recovery frames	No requirements	< 0,001	No requirements	< 0,001	BLER
Measured quality on DTCH	0,01 ± 30 %				BLER

NOTE: If the above Test Requirement differs from the Minimum Requirement then the Test Tolerance applied for this test is non-zero. The Test Tolerance for this test is defined in clause F.2 and the explanation of how the Minimum Requirement has been relaxed by the Test Tolerance is given in clause F.4.

7.10 Blind transport format detection

7.10.1 Definition and applicability

Performance of Blind transport format detection is determined by the Block Error Ratio (BLER) values and by the measured average transmitted DPCH_Ec/Ior value.

7.10.2 Minimum requirements

For the parameters specified in table 7.10.1 the average downlink $\frac{DPCH_E_c}{I_{or}}$ power ratio shall be below the specified value for the BLER and FDR shown in table 7.10.2. Table 7.10.3 defines the Transport Format Combinations Set for the downlink. The reference measurement channel used in this test case is defined in Annex C.4.

Table 7.10.1: Test parameters for Blind transport format detection

Parameter	Test 1	Test 2	Test 3	Test 4	Test 5	Test 6	Unit
\hat{I}_{or}/I_{oc}		-1			-3		dB
I_{oc}			-60				dBm / 3.84 MHz
Information Data Rate	12,2 (rate 1)	7,95 (rate 2)	1,95 (rate 3)	12,2 (rate 1)	7,95 (rate 2)	1,95 (rate 3)	kbps
Propagation condition	static						-
TFCI	multi-path fading case 3						-
			off				-

Table 7.10.2: The Requirements for DCH reception in Blind transport format detection

Test Number	$\frac{DPCH_E_c}{I_{or}}$	BLER	FDR
1	-17,7dB	10^{-2}	10^{-4}
2	-17,8dB	10^{-2}	10^{-4}
3	-18,4dB	10^{-2}	10^{-4}
4	-13,0dB	10^{-2}	10^{-4}
5	-13,2dB	10^{-2}	10^{-4}
6	-13,8dB	10^{-2}	10^{-4}
NOTE:	The value of DPCH_Ec/Ior, Ioc, and Ior/Ioc are defined in case of DPCH is transmitted.		

NOTE: In the test, 9 different Transport Format Combinations (table 7.10.3) are sent during the call set up procedure, so that the UE has to detect the correct transport format from these 9 candidates.

Table 7.10.3: Transport format combinations informed during the call set up procedure in the test

	1	2	3	4	5	6	7	8	9
DTCH	12,2 k	10,2 k	7,95 k	7,4 k	6,7 k	5,9 k	5,15 k	4,75 k	1,95 k
DCCH	2,4 k								

7.10.3 Test purpose

To verify the ability of the blind transport format detection to receive a predefined test signal, representing a static propagation channel for the wanted and for the co-channel signals from serving and adjacent cells, with a block error ratio (BLER) and false transport format detection ratio (FDR) not exceeding a specified value.

To verify the ability of the blind transport format detection to receive a predefined test signal, representing a multi-path propagation channel for the wanted and for the co-channel signals from serving and adjacent cells, with a block error ratio (BLER) and false transport format detection ratio (FDR) not exceeding a specified value.

7.10.4 Method of test

7.10.4.1 Initial conditions

Test environment: normal; see clauses G.2.1 and G.2.2.

Frequencies to be tested: mid range; see clause G.2.4.

1. Connect the SS and AWGN noise source to the UE antenna connector as shown in figure A.9 in the case for test 1-3. Connect the SS, multipath fading simulator and an AWGN noise source to the UE antenna connector as shown in figure A.10 in the case of test 4-6.
2. Set up a call according to the Generic call setup procedure TS34.108 [3] sub clause 7.3.2.
3. Set the test parameters for test 1-6 as specified table 7.10.4 and table 7.10.5.
4. Enter the UE into loopback test mode 2 and start the loopback test.
5. In the case of test 4-6, Setup fading simulator as fading condition case 3 which are described in table D.2.2.1.

Note: In loopback test mode 2 the UE may return any valid uplink Transport Format Combination.

7.10.4.2 Procedure

Measure BLER and FDR of DCH.

For FDR, the SS shall check the TFI of the UE transmitted transport format to verify that the UE has detected the correct downlink transport format.

In this test TF0 and TF10 on uplink DTCH shall be counted as block errors.

During the measurements downlink DCCH shall be continuously transmitted. When there is no signalling to transmit on downlink DCCH then dummy DCCH transmission as described in Annex C.9 shall be used.

NOTE: The TFCS size used in this test shall be 18 and not 9 as implied by TS 25.101 (and the NOTE above Table 7.10.3). Since the DCCH will be continuously transmitted and the DCCH is not used in the BTFD for the DTCH this does not have an impact on the BTFD performance.

7.10.5 Test requirements

The test parameters are specified in table 7.10.4.

Table 7.10.4: Test parameters for Blind transport format detection

Parameter	Test 1	Test 2	Test 3	Test 4	Test 5	Test 6	Unit
\hat{I}_{or}/I_{oc}		-0,7			-2,4		dB
I_{oc}				-60			dBm / 3.84 MHz
Information Data Rate	12,2 (rate 1)	7,95 (rate 2)	1,95 (rate 3)	12,2 (rate 1)	7,95 (rate 2)	1,95 (rate 3)	kbps
propagation condition		Static			multi-path fading case 3		-
TFCI			off				-

BLER and FDR shall not exceed the values at the DPCH_Ec/Ior specified in table 7.10.5.

Table 7.10.5: The Requirements for DCH reception in Blind transport format detection

Test Number	$\frac{DPCH_E_c}{I_{or}}$	BLER	FDR
1	-17,6dB	10^{-2}	10^{-4}
2	-17,7dB	10^{-2}	10^{-4}
3	-18,3dB	10^{-2}	10^{-4}
4	-12,9dB	10^{-2}	10^{-4}
5	-13,1dB	10^{-2}	10^{-4}
6	-13,7dB	10^{-2}	10^{-4}
NOTE: The value of DPCH_Ec/Ior, Ioc, and Ior/Ioc are defined in case of DPCH is transmitted.			

NOTE: If the above Test Requirement differs from the Minimum Requirement then the Test Tolerance applied for this test is non-zero. The Test Tolerance for this test is defined in clause F.2 and the explanation of how the Minimum Requirement has been relaxed by the Test Tolerance is given in clause F.4.

7.11 Demodulation of Paging Channel (PCH)

7.11.1 Definition and applicability

The receiver characteristics of paging channel are determined by the probability of missed paging message (Pm-p). PCH is mapped into the S-CCPCH and it is associated with the transmission of Paging Indicators (PI) to support efficient sleep-mode procedures.

The requirements and this test apply to all types of UTRA for the FDD UE for Release 4 and later releases.

7.11.2 Minimum requirements

For the parameters specified in table 7.11.1 the average probability of missed paging (Pm-p) shall be below the specified value in table 7.11.2. Power of downlink channels other than S-CCPCH and PICH are as defined in Table E.3.3.1 of Annex E. S-CCPCH structure is as defined in Annex C.7.

Table 7.11.1: Parameters for PCH detection

Parameter	Unit	Test 1	Test 2
Number of paging indicators per frame (Np)	-		72
Phase reference	-		P-CPICH
I_{oc}	dBm/3.84 MHz		-60
\hat{I}_{or}/I_{oc}	dB	-1	-3
Propagation condition		Static	Case 3

Table 7.11.2: Test requirements for PCH detection

Test Number	S-CCPCH_Ec/Ior	PICH_Ec/Ior	Pm-p
1	-14.8	-19	0.01
2	-9.8	-12	0.01

The reference for this requirement is TS 25.101 [1] clause 8.12.1.

7.11.3 Test purpose

To verify that average probability of missed paging (Pm-p) does not exceed a specified value.

7.11.4 Method of test

7.11.4.1 Initial conditions

Test environment: normal; see clauses G.2.1 and G.2.2.

Frequencies to be tested: mid range; see clause G.2.4.

- 1) Connect the SS and AWGN noise source to the UE antenna connector as shown in figure A.9 in the case of test 1. Connect the SS, multipath fading simulator and an AWGN noise source to the UE antenna connector as shown in figure A.10 in the case of test 2.
- 2) Set the test parameters for test 1-2 as specified in tables 7.11.3 and 7.11.4. In the case of test 2, Setup fading simulator as fading condition case 3 which are described in table D.2.2.1. Power of downlink channels other than S-CCPCH and PICH are as defined in table E.3.3.1. The S-CCPCH structure is as defined in Annex C.7 and includes 2 S-CCPCH according to TS 34.108 [3] section 6.1.1. The SCCPCH_Ec/Ior for the S-CCPCH carrying FACH is -7.0 dB while the SCCPCH_Ec/Ior for the S-CCPCH carrying PCH is defined in table 7.11.4.

7.11.4.2 Procedure

- 1) The UE is switched on.
- 2) An RRC connection is set up according to the generic set-up procedure specified in TS 34.108 [3] subclause 7.3.3 to place the UE in the CELL_PCH state.
- 3) The SS transmits the Paging type 1 message with used paging identity being a UTRAN identity and including the UE's assigned U-RNTI
- 4) If the UE responds with a CELL UPDATE message within 8 seconds, then a success is recorded. If the UE does not respond with a CELL UPDATE message within 8 seconds, a failure is recorded. On reception of the CELL UPDATE message the SS transmits 3 identical CELL UPDATE CONFIRM messages using CCCH on downlink FACH. Then the SS waits for 3 seconds to allow the UE time to move back to CELL_PCH state.
- 5) Repeat steps 3-4 according to Annex F.6.2 table 6.2.8.

NOTE: In the Step 4 above, the 3 identical CELL UPDATE CONFIRM messages are transmitted with the same RRC message sequence number. Transmitting 3 identical CELL UPDATE CONFIRM messages is done to increase the probability of correct message reception at the UE.

Specific Message Contents

All messages indicated above shall use the same content as described in the default message content in clause 9 of 34.108 [3] and clause 6.1.1 based on 6.1.0a.3 SIB default schedule of 34.108 [3], with the following exceptions:

PHYSICAL CHANNEL RECONFIGURATION (STEP 2)

Information Element	Value/remark
RRC State Indicator	CELL PCH
UTRAN DRX cycle length coefficient	6
Downlink information for each radio link - Primary CPICH info - Primary scrambling code	Reference to TS 34.108 [3] clause 6.1 "Default settings (FDD)"

SYSTEM INFORMATION BLOCK TYPE1 (STEP 2)

Information Element	Value/remark
- UE timers and constants in connected mode	
- T302	1000 ms

SYSTEM INFORMATION BLOCK TYPE5 (STEP 2)

Information Element	Value/remark
- SIB6 indicator	TRUE
- PICH Power offset	-9 dB (in Test 1) -2 dB (in Test 2)
- CHOICE Mode	FDD
- AICH Power offset	0 dB
...	
- Secondary CCPCH system information	(For 2 SCCPCHs)
- Secondary CCPCH info	(SCCPCH for standalone PCH)
- CHOICE mode	FDD
- Secondary scrambling code	Not Present
- STTD indicator	FALSE
- Spreading factor	128
- Code number	3
- Pilot symbol existence	FALSE
- TFCI existence	FALSE
- Fixed or Flexible position	Fixed
- Timing offset	30
- TFCS	
- CHOICE TFCI signalling	Normal
- TFCI Field 1 information	
- CHOICE TFCS representation	Complete reconfiguration
- TFCS complete reconfiguration information	
- CHOICE CTFC Size	2 bit
- CTFC information	0
- Power offset information	Not Present
- CTFC information	1
- Power offset information	Not Present
- FACH/PCH information	
- TFS	(PCH)
- CHOICE Transport channel type	Common transport channels
- Dynamic Transport format information	
- RLC Size	240
- Number of TB and TTI List	
- Number of Transport blocks	0
- Number of Transport blocks	1
- CHOICE Mode	FDD
- CHOICE Logical channel List	ALL
- Semi-static Transport Format information	
- Transmission time interval	10 ms
- Type of channel coding	Convolutional
- Coding Rate	1/2
- Rate matching attribute	256
- CRC size	16 bit
- Transport channel Identity	12 (for PCH)
- CTCH indicator	FALSE

- PICH info	
- CHOICE mode	FDD
- Channelisation code	2
- Number of PI per frame	72
- STTD indicator	FALSE
- Secondary CCPCH info	(SCCPCH including two FACHs)
- CHOICE mode	FDD
- Secondary scrambling code	Not Present
- STTD indicator	FALSE
- Spreading factor	64
- Code number	2
- Pilot symbol existence	FALSE
- TFCI existence	TRUE (default value)
- Fixed or Flexible position	Flexible (default value)
- Timing offset	Not Present
	Absence of this IE is equivalent to default value 0

PAGING TYPE 1 (STEP 3)

Information Element	Value/remark
Message Type	
Paging record list	
-Paging record	
- CHOICE Used paging identity	Utran-Identity
-U-RNTI	
-SRNC-Identity	'000000000001'B
-S-RNTI	'00000000000000000001'B
BCCH modification info	Not Present

CELL UPDATE (STEP 4):

Information Element	Value/remark	Version
Cell update cause	paging response	

CELL UPDATE CONFIRM (STEP 4):

Information Element	Value/remark
RRC transaction identifier	0
Activation time	Not Present
RRC State indicator	CELL_PCH
UTRAN DRX cycle length coefficient	6

7.11.5 Test requirements

For the parameters specified in table 7.11.3 the average probability of missed paging (P_{m-p}) shall be below the specified value in table 7.11.4. Power of downlink channels other than S-CCPCH and PICH are as defined in Table E.3.3.1 of Annex E. S-CCPCH structure is as defined in Annex C.7.

Table 7.11.3: Parameters for PCH detection

Parameter	Unit	Test 1	Test 2
Number of paging indicators per frame (N_p)	-	72	
Phase reference	-	P-CPICH	
I_{oc}	dBm/3.84 MHz	-60	
\hat{I}_{or}/I_{oc}	dB	-0.6	-2.3
Propagation condition		Static	Case 3

Table 7.11.4: Test requirements for PCH detection

Test Number	S-CCPCH_Ec/Ior	PICH_Ec/Ior	Pm-p
1	-14.8	-19	0.01
2	-9.8	-12	0.01

NOTE: If the above Test Requirement differs from the Minimum Requirement then the Test Tolerance applied for this test is non-zero. The Test Tolerance for this test is defined in clause F.2 and the explanation of how the Minimum Requirement has been relaxed by the Test Tolerance is given in clause F.4.

7.12 Detection of Acquisition Indicator (AI)

7.12.1 Definition and applicability

The receiver characteristics of Acquisition Indicator (AI) are determined by the probability of false alarm Pfa and probability of correct detection Pd. Pfa is defined as a conditional probability of detection of AI signature given that a AI signature was not transmitted. Pd is defined as a conditional probability of correct detection of AI signature given that the AI signature is transmitted.

The requirements and this test apply to all types of UTRA for the FDD UE for Release 4 and later releases.

7.12.2 Minimum requirements

For the parameters specified in table 7.12.1 the Pfa and 1-Pd shall not exceed the specified values in table 7.12.2. Power of downlink channels other than AICH is as defined in Table E.3.3.1 of Annex E.

Table 7.12.1: Parameters for AI detection

Parameter	Unit	Test 1
Phase reference	-	P-CPICH
I_{oc}	dBm/3.84 MHz	-60
Number of other transmitted AI signatures on AICH	-	0
\hat{I}_{or}/I_{oc}	dB	-1
AICH_Ec/Ior	dB	-22.0
AICH Power Offset	dB	-12.0
Propagation condition	-	Static

Note that AICH_Ec/Ior can not be set. Its value is calculated from other parameters and it is given for information only. (AICH_Ec/Ior = AICH Power Offset + CPICH_Ec/Ior)

Table 7.12.2: Test requirements for AI detection

Test Number	Pfa	1-Pd
1	0.01	0.01

The reference for this requirement is TS 25.101 [1] clause 8.13.1.

7.12.3 Test purpose

To verify that average probability of false detection of AI (Pfa) and average probability of missed AI (1-Pd) do not exceed specified values.

7.12.4 Method of test

7.12.4.1 Initial conditions

Test environment: normal; see clauses G.2.1 and G.2.2.

Frequencies to be tested: mid range; see clause G.2.4.

- 1) Connect the SS and AWGN noise source to the UE antenna connector as shown in figure A.9.
- 2) Set the test parameters for test 1 as specified in tables 7.12.4 and 7.12.5. Power of downlink channels other than AICH are as defined in Table E.3.3.1 of Annex E.

Table 7.12.3 UE parameters for AI test

Parameter	Unit	Set 1	Set 2
Maximum number of preamble ramping cycles(Mmax)		2	2
Maximum number of preambles in one preamble cycle (preamble retrans max)		32	12
Back-off time (Tb01=10ms*NB01) (NB01min=NB01max=10)	ms	100	100
Power ramp step when no acquisition indicator is received (power offset p0)	dB	1	3

Table 7.12.4 SS parameters for AI test

Parameter	Unit	Value
Primary CPICH DL TX power	dBm	-8
UL interference	dBm	-82
SIR in open loop power control (Constant value)	dB	-10

See reference TS25.331 [8] clause 8.5.7 Open loop power control to calculate Pinitial. See also reference TS25.214 [5] subclause 6 step 6.3.

7.12.4.2 Procedure

- 1) The UE is switched on.
- 2) The SS and the UE shall perform location registration procedure as specified in TS34.108 [3] clause 7.2.2. UE parameters are set as defined in table 7.12.3 Set 1.
- 3) SS sends the Paging type 1 message in idle mode with used paging identity being a CN identity and including the UE's assigned IMSI.
- 4) UE starts transmitting RACH preambles at level P=Pinitial.
- 5) SS does not send AI. If UE sends a new preamble a success for calculating Pfa is recorded. This step is repeated until UE stops sending preambles. SS does not calculate Pfa for the first preamble of every preamble cycles.
- 6) UE stops sending preambles. If number of sent preambles in the preamble cycle < preamble_retrans_max a failure for calculating Pfa is recorded and test continues from step 3. If number of preamble cycles $M \neq M_{max}$, a new preamble cycle is initiated and test continues from step 4. If number of preamble cycles $M = M_{max}$ then test continues from step 3.
- 7) Repeat steps 5-6 according to Annex F.6.2 table 6.2.8.
- 8) UE parameters are set as defined in table 7.12.3 Set 2 by modification of system information block 5.
- 9) SS sends the Paging type 1 message in idle mode with used paging identity being a CN identity and including the UE's assigned IMSI.
- 10) UE starts transmitting RACH preambles.
- 11) SS responds with AI signature containing NACK in AICH.
- 12) If UE stops sending preambles, a success for calculating Pd is recorded. If UE does not stop sending preambles, a failure for calculating Pd is recorded.

13) Repeat steps 9-12 according to Annex F.6.2 table 6.2.8.

Specific Message Contents

All messages indicated above shall use the same content as described in the default message content in clause 9 of 34.108 [3] and clause 6.1.0b of 34.108 [3], with the following exceptions:

SYSTEM INFORMATION BLOCK TYPE1

Information Element	Value/remark
- UE timers and constants in idle mode	
- T300	1000 ms

SYSTEM INFORMATION BLOCK TYPE5

Information Element	Value/remark
AICH Power Offset	-12

7.12.5 Test requirements

For the parameters specified in table 7.12.5 the Pfa and 1-Pd shall not exceed the specified values in table 7.12.6. Power of downlink channels other than AICH are as defined in Table E.3.3.1 of Annex E.

Table 7.12.5: Parameters for AI detection

Parameter	Unit	Test 1
Phase reference	-	P-CPICH
I_{oc}	dBm/3.84 MHz	-60
Number of other transmitted AI signatures on AICH	-	0
\hat{I}_{or}/I_{oc}	dB	-0.6
AICH E_c/I_{or}	dB	-22.0
AICH Power Offset	dB	-12.0
Propagation condition	-	Static

Table 7.12.6: Test requirements for AI detection

Test Number	Pfa	1-Pd
1	0.01	0.01

NOTE: If the above Test Requirement differs from the Minimum Requirement then the Test Tolerance applied for this test is non-zero. The Test Tolerance for this test is defined in clause F.2 and the explanation of how the Minimum Requirement has been relaxed by the Test Tolerance is given in clause F.4.

8 Requirements for support of RRM

8.1 General

The cell configuration mapping between cells as defined in TS 34.121 and cells as defined in TS 34.108 [3] section 6.1.4 is described in Annex K.

When DCCH has been configured on downlink DCH then DCCH Data shall be continuously transmitted on downlink DCH. When there is no signalling to transmit on downlink DCCH then dummy DCCH transmission as described in Annex C.9 shall be used.

The MAC header transmission on HS-DSCH for all E-DCH test cases shall use a correct MAC-hs header consistent with the actual HSDPA transmission.

For HSDPA test cases without E-DCH, the MAC headers on HS-DSCH shall be according to Annex C.9A.

The DL and UL RLC SDU size for all E-DCH tests in clause 8 shall be set according to Annex C.11.3.

For the UE which supports both Band I and Band VI operating frequencies, the inter-frequency requirements for Band VI shall apply to the multi-band UE by measuring a Band I frequency while in Band VI to prevent interference. Otherwise, the Band VI inter-frequency requirements cannot be tested.

Parameters given in table 8.1 will be used throughout this section, unless otherwise stated by the test case.

Table 8.1: Test parameters for UTRAN Cell (FDD)

Parameter	Unit	UTRAN Cells
Qrxlevmin	dBm	-115

8.1.1 Definition of Additive White Gaussian Noise (AWGN) Interferer

See clause D.1.1.

8.2 Idle Mode Tasks

8.2.1 Cell Selection

Void.

8.2.2 Cell Re-Selection

8.2.2.1 Scenario 1: Single carrier case

8.2.2.1.1 Definition and applicability

The cell re-selection delay is defined as the time from a change of cell levels to the moment when this change makes the UE camp on a new cell, and starts to send preambles on the PRACH for the RRC CONNECTION REQUEST message to perform a Location Updating procedure (MM) or Routing Area Updating procedure (GMM) on the new cell.

The requirements and this test apply to the FDD UE.

8.2.2.1.2 Minimum requirement

The cell re-selection delay shall be less than 8 s with a DRX cycle length of 1.28 s.

The rate of correct cell reselections observed during repeated tests shall be at least 90% with a confidence level of 95 %.

NOTE: The cell re-selection delay can be expressed as: $T_{\text{evaluateFDD}} + T_{\text{SI}}$, where:

$T_{\text{evaluateFDD}}$	See table 4.1 in TS 25.133 [2] clause 4.2.2.
T_{SI}	Maximum repetition period of relevant system info blocks that needs to be received by the UE to camp on a cell. 1280 ms is assumed in this test case.

This gives a total of 7.68 s, allow 8s in the test case.

The normative reference for this requirement is TS 25.133 [2] clauses 4.2.2.2 and A.4.2.1.

8.2.2.1.3 Test purpose

To verify that the UE meets the minimum requirement.

8.2.2.1.4 Method of test

8.2.2.1.4.1 Initial conditions

Test environment: normal; see clauses G.2.1 and G.2.2.

Frequencies to be tested: mid range; see clause G.2.4.

This scenario implies the presence of 1 carrier and 6 cells as given in tables 8.2.2.1.1 to 8.2.2.1.3. The UE is requested to monitor neighbouring cells on 1 carrier. The maximum repetition period of the relevant system info blocks that needs to be received by the UE to camp on a cell shall be 1 280 ms. Cell 1 and cell 2 shall belong to different Location Areas.

Table 8.2.2.1.1: Scenario 1: General test parameters for Cell Re-selection single carrier multi-cell case

Parameter		Unit	Value	Comment
Initial condition	Active cell		Cell2	
	Neighbour cells		Cell1, Cell3, Cell4, Cell5, Cell6	
Final condition	Active cell		Cell1	
SYSTEM INFORMATION BLOCK TYPE 1 - CN common GSM-MAP NAS system information	-		00 80(H) → Cell 1 00 81(H) → Cell 2	This identity should be set as different value from the neighbour cell so that a Location Updating procedure(MM) or a Routing Area Updating procedure(GMM) is performed when UE selects more suitable cell in idle state.
Access Service Class (ASC#0) - Persistence value	-		1	Selected so that no additional delay is caused by the random access procedure. The value shall be used for all cells in the test.
HCS				Not used
T_{SI}		ms	1280	See Annex I for the SIB repetition period of system information blocks.
DRX cycle length		s	1,28	The value shall be used for all cells in the test.
T1		s	15	T1 need to be defined so that cell re-selection reaction time is taken into account.
T2		s	15	T2 need to be defined so that cell re-selection reaction time is taken into account.

Table 8.2.2.1.2: Scenario 1: Test parameters for Cell re-selection single carrier multi cell

Parameter	Unit	Cell 1		Cell 2		Cell 3		Cell 4		Cell 5		Cell 6	
		T1	T2	T1	T2	T1	T2	T1	T2	T1	T2	T1	T2
UTRA RF Channel Number		Channel1		Channel1		Channel1		Channel1		Channel1		Channel1	
CPICH_Ec/Ior	dB	-10		-10		-10		-10		-10		-10	
PCCPCH_Ec/Ior	dB	-12		-12		-12		-12		-12		-12	
SCH_Ec/Ior	dB	-12		-12		-12		-12		-12		-12	
PICH_Ec/Ior	dB	-15		-15		-15		-15		-15		-15	
OCNS_Ec/Ior	dB	-0,941		-0,941		-0,941		-0,941		-0,941		-0,941	
\hat{I}_{or}/I_{oc}	dB	7,3	10,27	10,27	7,3	0,27	0,27	0,27	0,27	-4.8	-7.4	-4.8	-7.4
\hat{I}_{or} (Note 1)	dBm	-62.73	-59.73	-59.73	-62.73	-69.73	-69.73	-69.73	-69.73	-74.75	-77.39	-74.75	-77.39
I_{oc}	dBm / 3,84 MHz	-70											
CPICH_Ec/Io	dB	-16	-13	-13	-16	-23		-23		-23		-23	
Propagation Condition		AWGN											
Cell_selection_and_reselection_quality_measure		CPICH E _c /N ₀		CPICH E _c /N ₀		CPICH E _c /N ₀		CPICH E _c /N ₀		CPICH E _c /N ₀		CPICH E _c /N ₀	
Qqualmin	dB	-20		-20		-20		-20		-20		-20	
Qrxlevmin	dBm	-115		-115		-115		-115		-115		-115	
UE_TXPWR_MAX_RACH	dB	21		21		21		21		21		21	
Qoffset2 _{s, n}	dB	C1, C2: 0 C1, C3: 0 C1, C4: 0 C1, C5: 0 C1, C6: 0		C2, C1: 0 C2, C3: 0 C2, C4: 0 C2, C5: 0 C2, C6: 0		C3, C1: 0 C3, C2: 0 C3, C4: 0 C3, C5: 0 C3, C6: 0		C4, C1: 0 C4, C2: 0 C4, C3: 0 C4, C5: 0 C4, C6: 0		C5, C1: 0 C5, C2: 0 C5, C3: 0 C5, C4: 0 C5, C6: 0		C6, C1: 0 C6, C2: 0 C6, C3: 0 C6, C4: 0 C6, C5: 0	
Qhyst2	dB	0		0		0		0		0		0	
Treselection	s	0		0		0		0		0		0	
Sintrasearch	dB	not sent		not sent		not sent		not sent		not sent		not sent	

NOTE 1 The nominal \hat{I}_{or} values, although not explicitly defined in 25.133 [2] are added here since they are implied and need to be identified so that the test equipment can be configured.

8.2.2.1.4.2 Procedure

- 1) The SS activates cell 1-6 with T1 defined parameters in table 8.2.2.1.3 and monitors cell 1 and 2 for random access requests from the UE.
- 2) The UE is switched on.
- 3) The SS and the UE shall perform a first registration procedure on cell2.
- 4) 15 s after step 3 has completed, the parameters are changed to that as described for T2 in table 8.2.2.1.3.
- 5) The SS waits for random access requests from the UE. If the UE responds on cell 1 within 8 s from the beginning of time period T2 then the number of successful tests is increased by one. The SS and the UE shall perform a Location Updating procedure (MM) or a Routing Area Updating procedure (GMM) on cell1.
- 6) After 15 s from the beginning of time period T2, the parameters are changed to that as described for T1 in table 8.2.2.1.3.
- 7) The SS waits for random access requests from the UE. If the UE responds on cell 2 within 8 s from the beginning of time period T1 then the number of successful tests is increased by one. The SS and the UE shall perform a Location Updating procedure(MM) or a Routing Area Updating procedure (GMM) on cell2.
- 8) After 15 s from the beginning of time period T1, the parameters are changed to that as described for T2.
- 9) Repeat step 5) to 8) until the confidence level according to annex F.6.2 is achieved.

NOTE 1: The time required for receiving all the relevant system information data according to the reception procedure and the RRC procedure delay of system information blocks defined in 25.331 for a UTRAN cell. Since the maximum time to read the relevant system info blocks that needs to be received by the UE to camp on a cell is 1420ms (see note 2) and the maximum RRC procedure delay for reception system information block is 100ms, 1520 ms is assumed in this test case. Therefore this gives a total of 7.92s.(Minimum requirement + 240ms), allow 8s in the test case.

NOTE 2: The maximum repetition period of the relevant system info blocks that needs to be received by the UE to camp on a cell is 1280ms. The Master Information Block (MIB) is repeated every 8 frame and SIB5 (and SIB11) is segmented into 4 segments where the first segment is scheduled adjacent to the MIB at SIB_POS=40 and the other three segments are scheduled after the MIB (SIB_POS=42, 44 and 46). The maximum time for a UE to read SIB5 will occur if the UE start reading the BCH at the SFN after the MIB located prior to the first segment of SIB5 (SIB_POS 32). Then the UE will not be able to read SIB5 until the second occurrence of SIB5, which will happen at SIB_POS 46 + 1280ms. This gives that the maximum time for the UE to read the relevant system info will be 1420ms ((SIB_POS 46 – SIB_POS 32)*10ms +1280ms).

8.2.2.1.5 Test requirements

For the test to pass, the total number of successful attempts shall be more than 90% of the cases with a confidence level of 95 %.

Table 8.2.2.1.3: Scenario 1: Test requirements for Cell re-selection single carrier multi cell

Parameter	Unit	Cell 1		Cell 2		Cell 3		Cell 4		Cell 5		Cell 6	
		T1	T2	T1	T2	T1	T2	T1	T2	T1	T2	T1	T2
UTRA RF Channel Number		Channel1		Channel1		Channel1		Channel1		Channel1		Channel1	
CPICH_Ec/Ior	dB	-9.4		-9.4		-10.5		-10.5		-10.5		-10.5	
PCCPCH_Ec/Ior	dB	-11.4		-11.4		-12.5		-12.5		-12.5		-12.5	
SCH_Ec/Ior	dB	-11.4		-11.4		-12.5		-12.5		-12.5		-12.5	
PICH_Ec/Ior	dB	-14.4		-14.4		-15.5		-15.5		-15.5		-15.5	
OCNS_Ec/Ior	dB	-1.10		-1.10		-0.83		-0.83		-0.83		-0.83	
\hat{I}_{or}/I_{oc} Note 1	dB	7.00	10.40	10.40	7.00	0.30	0.30	0.30	0.30	0.30	0.30	0.30	0.30
\hat{I}_{or}	dBm	-63.0	-59.6	-59.6	-63.0	-69.7	-69.7	-69.7	-69.7	-69.7	-69.7	-69.7	-69.7
I_{oc}	dBm / 3,84 MHz	-70											
CPICH_Ec/Io Note 1	dB	-15.7	-12.3	-12.3	-15.7	-23.5	-23.5	-23.5	-23.5	-23.5	-23.5	-23.5	-23.5

All other parameters and conditions specified in table 8.2.2.1.2 are unchanged.

NOTE 1: These parameters are not directly settable, but are derived by calculation from the settable parameters.

NOTE 2: If the above Test Requirement differs from the Minimum Requirement then the Test Tolerance applied for this test is non-zero. The Test Tolerance for this test is defined in clause F.2 and the explanation of how the Minimum Requirement has been relaxed by the Test Tolerance is given in clause F.4.

8.2.2.2 Scenario 2: Multi carrier case

8.2.2.2.1 Definition and applicability

The cell re-selection delay is defined as the time from a change of cell levels to the moment when this change makes the UE camp on a new cell, and starts to send preambles on the PRACH for the RRC CONNECTION REQUEST message to perform a Location Updating procedure(MM) or Routing Area Updating procedure (GMM) on the new cell.

The requirements and this test apply to the FDD UE.

8.2.2.2.2 Minimum requirement

The cell re-selection delay shall be less than 8 s with a DRX cycle length of 1.28 s.

The rate of correct cell reselections observed during repeated tests shall be at least 90% with a confidence level of 95 %.

NOTE: The cell re-selection delay can be expressed as: $T_{\text{evaluateFDD}} + T_{\text{SI}}$, where:

$T_{\text{evaluateFDD}}$	See table 4.1 in TS 25.133 [2] clause 4.2.2.
T_{SI}	Maximum repetition period of relevant system info blocks that needs to be received by the UE to camp on a cell. 1280 ms is assumed in this test case.

This gives a total of 7.68 s, allow 8s in the test case.

The normative reference for this requirement is TS 25.133 [2] clauses 4.2.2.3 and A.4.2.2.

8.2.2.2.3 Test purpose

To verify that the UE meets the minimum requirement.

8.2.2.2.4 Method of test

8.2.2.2.4.1 Initial conditions

Test environment: normal; see clauses G.2.1 and G.2.2.

Frequencies to be tested: mid range; see clause G.2.4.

This scenario implies the presence of 2 carriers and 6 cells as given in tables 8.2.2.2.1 to 8.2.2.2.3. The UE is requested to monitor neighbouring cells on 2 carriers. The maximum repetition period of the relevant system info blocks that needs to be received by the UE to camp on a cell shall be 1 280 ms. Cell 1 and cell 2 shall belong to different Location Areas.

Table 8.2.2.2.1: Scenario 2: General test parameters for Cell Re-selection in multi carrier case

Parameter	Unit	Value	Comment
Initial condition	Active cell	Cell2	
	Neighbour cells	Cell1, Cell3, Cell4, Cell5, Cell6	
Final condition	Active cell	Cell1	
SYSTEM INFORMATION BLOCK TYPE 1 - CN common GSM-MAP NAS system information	-	00 80(H) → Cell 1 00 81(H) → Cell 2	This identity should be set as different value from the neighbour cell so that a Location Updating procedure (MM) or a Routing Area Updating procedure (GMM) is performed when UE selects more suitable cell in idle state.
Access Service Class (ASC#0) - Persistence value	-	1	Selected so that no additional delay is caused by the random access procedure. The value shall be used for all cells in the test.
HCS			Not used
T _{SI}	ms	1280	See Annex I for the SIB repetition period of system information blocks.
DRX cycle length	S	1,28	The value shall be used for all cells in the test.
T1	s	30	T1 need to be defined so that cell re-selection reaction time is taken into account.
T2	s	15	T2 need to be defined so that cell re-selection reaction time is taken into account.
NOTE: Monitored cell list size has 6 cells on 2 carriers. See Annex I for the cell information.			

Table 8.2.2.2.2: Scenario 2: Test parameters for Cell re-selection multi carrier multi cell

Parameter	Unit	Cell 1		Cell 2		Cell 3		Cell 4		Cell 5		Cell 6	
		T1	T2	T1	T2	T1	T2	T1	T2	T1	T2	T1	T2
UTRA RF Channel Number		Channel 1		Channel 2		Channel 1		Channel 1		Channel 2		Channel 2	
CPICH_Ec/Ior	dB	-10		-10		-10		-10		-10		-10	
PCCPCH_Ec/Ior	dB	-12		-12		-12		-12		-12		-12	
SCH_Ec/Ior	dB	-12		-12		-12		-12		-12		-12	
PICH_Ec/Ior	dB	-15		-15		-15		-15		-15		-15	
OCNS_Ec/Ior	dB	-0.941		-0.941		-0.941		-0.941		-0.941		-0.941	
\hat{I}_{or}/I_{oc}	dB	-3.4	2.2	2.2	-3.4	-7.4	-4.8	-7.4	-4.8	-4.8	-7.4	-4.8	-7.4
\hat{I}_{or} (Note 1)	dBm	-73.39	-67.75	-67.75	-73.39	-77.39	-74.75	-77.39	-74.75	-74.75	-77.39	-74.75	-77.39
I_{oc}	dBm / 3.84 MHz	-70											
CPICH_Ec/Io	dB	-16	-13	-13	-16	-20		-20		-20		-20	
Propagation Condition		AWGN											
Cell_selection_and_reselection_quality_measure		CPICH E _c /N ₀		CPICH E _c /N ₀		CPICH E _c /N ₀		CPICH E _c /N ₀		CPICH E _c /N ₀		CPICH E _c /N ₀	
Qqualmin	dB	-20		-20		-20		-20		-20		-20	
Qrxlevmin	dBm	-115		-115		-115		-115		-115		-115	
UE_TXPWR_MAX_RACH	dB	21		21		21		21		21		21	
Qoffset2 _{s, n}	dB	C1, C2: 0 C1, C3: 0 C1, C4: 0 C1, C5: 0 C1, C6: 0		C2, C1: 0 C2, C3: 0 C2, C4: 0 C2, C5: 0 C2, C6: 0		C3, C1: 0 C3, C2: 0 C3, C4: 0 C3, C5: 0 C3, C6: 0		C4, C1: 0 C4, C2: 0 C4, C3: 0 C4, C5: 0 C4, C6: 0		C5, C1: 0 C5, C2: 0 C5, C3: 0 C5, C4: 0 C5, C6: 0		C6, C1: 0 C6, C2: 0 C6, C3: 0 C6, C4: 0 C6, C5: 0	
Qhyst2	dB	0		0		0		0		0		0	
Treselection	s	0		0		0		0		0		0	
Sintrasearch	dB	not sent		not sent		not sent		not sent		not sent		not sent	
Sintersearch	dB	not sent		not sent		not sent		not sent		not sent		not sent	

NOTE 1 The nominal \hat{I}_{or} values, although not explicitly defined in 25.133 [2] are added here since they are implied and need to be identified so that the test equipment can be configured.

8.2.2.2.4.2 Procedures

- 1) The SS activates cell 1-6 with T1 defined parameters in table 8.2.2.2.3 and monitors cell 1 and 2 for random access requests from the UE.
- 2) The UE is switched on.
- 3) The SS and the UE shall perform a first location registration procedure on cell2.
- 4) 30 s after step3 has completed, the parameters are changed to that as described for T2 in table 8.2.2.2.3.
- 5) The SS waits for random access request from the UE. If the UE responds on cell 1 within 8 s from the beginning of time period T2 then the number of successful tests is increased by one. The SS and the UE shall perform a Location Updating procedure (MM) or a Routing Area Updating procedure (GMM) on cell1.
- 6) After another 15 s from the beginning of time period T2, the parameters are changed to that as described for T1 in table 8.2.2.2.3.
- 7) The SS waits for random access requests from the UE. If the UE responds on cell 2 within 8 s from the beginning of time period T1 then the number of successful tests is increased by one. The SS and the UE shall perform a Location Updating procedure (MM) or a Routing Area Updating procedure (GMM) on cell2.
- 8) After 15 s from the beginning of time period T1, the parameters are changed as described for T2.
- 9) Repeat step 5) to 8) until the confidence level according to annex F.6.2 is achieved.

NOTE 1: T1 is initially 30 s to allow enough time for the UE to search for cells as it has no prior knowledge of these.

NOTE 2: The time required for receiving all the relevant system information data according to the reception procedure and the RRC procedure delay of system information blocks defined in 25.331 for a UTRAN cell. Since the maximum time to read the relevant system info blocks that needs to be received by the UE to camp on a cell is 1420ms (see note 3) and the maximum RRC procedure delay for reception system information block is 100ms, 1520 ms is assumed in this test case. Therefore this gives a total of 7.92s (Minimum requirement + 240ms), allow 8s in the test case.

NOTE 3: The maximum repetition period of the relevant system info blocks that needs to be received by the UE to camp on a cell is 1280ms. The Master Information Block (MIB) is repeated every 8 frame and SIB5 (and SIB11) is segmented into 4 segments where the first segment is scheduled adjacent to the MIB at SIB_POS=40 and the other three segments are scheduled after the MIB (SIB_POS=42, 44 and 46). The maximum time for a UE to read SIB5 will occur if the UE start reading the BCH at the SFN after the MIB located prior to the first segment of SIB5 (SIB_POS 32). Then the UE will not be able to read SIB5 until the second occurrence of SIB5, which will happen at SIB_POS 46 + 1280ms. This gives that the maximum time for the UE to read the relevant system info will be 1420ms ((SIB_POS 46 – SIB_POS 32)*10ms +1280ms).

8.2.2.2.5 Test requirements

For the test to pass, the total number of successful tests shall be more than 90% of the cases with a confidence level of 95 %.

Table 8.2.2.2.3: Scenario 2: Test parameters for Cell re-selection multi carrier multi cell

Parameter	Unit	Cell 1		Cell 2		Cell 3		Cell 4		Cell 5		Cell 6	
		T1	T2	T1	T2	T1	T2	T1	T2	T1	T2	T1	T2
UTRA RF Channel Number		Channel 1		Channel 2		Channel 1		Channel 1		Channel 2		Channel 2	
CPICH_Ec/Ior	dB	-9.3		-9.3		-10.8		-10.8		-10.8		-10.8	
PCCPCH_Ec/Ior	dB	-11.3		-11.3		-12.8		-12.8		-12.8		-12.8	
SCH_Ec/Ior	dB	-11.3		-11.3		-12.8		-12.8		-12.8		-12.8	
PICH_Ec/Ior	dB	-14.3		-14.3		-15.8		-15.8		-15.8		-15.8	
OCNS_Ec/Ior	dB	-1.13		-1.13		-0.77		-0.77		-0.77		-0.77	
\hat{I}_{or}/I_{oc} Note 1	dB	-3.40	+4.80	+4.80	-3.40	-7.40	-3.00	-7.40	-3.00	-3.00	-7.40	-3.00	-7.40
\hat{I}_{or}	dBm	-73.4	-67.0	-67.0	-73.4	-77.4	-74.8	-77.4	-74.8	-74.8	-77.4	-74.8	-77.4
I_{oc}	dBm/3.84 MHz	-70.0	-71.8	-71.8	-70.0	-70.0	-71.8	-70.0	-71.8	-71.8	-70.0	-71.8	-70.0
CPICH_Ec/Io Note 1	dB	-15.3	-11.5	-11.5	-15.3	-20.8	-20.8	-20.8	-20.8	-20.8	-20.8	-20.8	-20.8

All other parameters and conditions specified in table 8.2.2.2 are unchanged.

NOTE 1: These parameters are not directly settable, but are derived by calculation from the settable parameters.

NOTE 2: If the above Test Requirement differs from the Minimum Requirement then the Test Tolerance applied for this test is non-zero. The Test Tolerance for this test is defined in clause F.2 and the explanation of how the Minimum Requirement has been relaxed by the Test Tolerance is given in clause F.4.

8.2.3 UTRAN to GSM Cell Re-Selection

8.2.3.1 Scenario 1: Both UTRA and GSM level changed

8.2.3.1.1 Definition and applicability

The cell re-selection delay is defined as the time from a change of cell levels to the moment when this change makes the UE camp on a new cell and starts to send the RR Channel Request message for location update to the new cell.

The requirements and this test apply to the combined FDD and GSM UE.

8.2.3.1.2 Minimum requirement

The cell re-selection delay shall be less than $26\text{ s} + T_{\text{BCCH}}$, where T_{BCCH} is the maximum time allowed to read BCCH data from GSM cell, see TS 05.08 [20] for R99 and TS 45.008 [30] for Rel-4 and later releases.

The rate of correct cell reselections observed during repeated tests shall be at least 90% with a confidence level of 95 %.

NOTE: The cell re-selection delay can be expressed as: $4 * T_{\text{measureGSM}} + T_{\text{BCCH}}$, where:

$T_{\text{measureGSM}}$ See table 4.1 in TS 25.133 [2] clause 4.2.2.

T_{BCCH} Maximum time allowed to read BCCH data from GSM cell, see TS 05.08 [20] for R99 and TS 45.008 [30] for Rel-4 or later releases.
According to [20] and [30], the maximum time allowed to read the BCCH data, when being synchronized to a BCCH carrier, is 1.9 s.

This gives a total of $25.6\text{ s} + T_{\text{BCCH}}$, allow $26\text{ s} + T_{\text{BCCH}}$ in the test case.

The normative reference for this requirement is TS 25.133 [2] clauses 4.2.2 and A.4.3.1.

8.2.3.1.3 Test purpose

To verify that the UE meets the minimum requirement.

8.2.3.1.4 Method of test

8.2.3.1.4.1 Initial conditions

Test environment: normal; see clauses G.2.1 and G.2.2.

Frequencies to be tested: mid range; see clause G.2.4.

This scenario implies the presence of 1 UTRAN serving cell, and 1 GSM cell to be re-selected, as given in tables 8.2.3.1.1 to 8.2.3.1.5. The UE is requested to monitor neighbouring cells on 1 UMTS carrier and 12 GSM cells. Cell 1 and cell 2 shall belong to different Location Areas.

Table 8.2.3.1.1: Scenario 1: General test parameters for UTRAN to GSM Cell Re-selection

Parameter		Unit	Value	Comment
Initial condition	Active cell		Cell1	
	Neighbour cell		Cell2	
Final condition	Active cell		Cell2	
HCS				Not used
DRX cycle length		s	1.28	
Monitored cell list size			12 GSM neighbours including the ARFCN of cell 2	NOTE: See Annex I for cell information
T1		s	45	
T2		s	35	

Table 8.2.3.1.2: Scenario 1: Test parameters for Cell re-selection UTRAN to GSM cell case (cell 1)

Parameter	Unit	Cell 1 (UTRA)	
		T1	T2
UTRA RF Channel Number		Channel 1	
CPICH_Ec/Ior	dB	-10	
PCCPCH_Ec/Ior	dB	-12	
SCH_Ec/Ior	dB	-12	
PICH_Ec/Ior	dB	-15	
OCNS_Ec/Ior	dB	-0.941	
\hat{I}_{or}/I_{oc}	dB	0	-5
I_{oc}	dBm/3.84 MHz	-70	
CPICH_Ec/Io	dB	-13	-16.2
CPICH_RSCP	dBm	-80	-85
Propagation Condition		AWGN	
Cell_selection_and_reselection_quality_measure		CPICH E _c /N ₀	
Qqualmin	dB	-20	
Qrxlevmin	dBm	-115	
UE_TXPWR_MAX_RACH	dBm	21	
Qoffset1 _{s,n}	dB	C1, C2: 0	
Qhyst1	dB	0	
Treselection	s	0	
Ssearch _{RAT}	dB	not sent	

Table 8.2.3.1.3: Scenario 1: Test parameters for Cell re-selection UTRAN to GSM cell case (cell 2)

Parameter	Unit	Cell 2 (GSM)	
		T1	T2
Absolute RF Channel Number		ARFCN 1	
RXLEV	dBm	-90	-75
RXLEV_ACCESS_MIN	dBm	-104	
MS_TXPWR_MAX_CCH	dBm	33	
FDD_Qmin	dB	-14	
Qsearch_I	-	always	

Specific 2 quarter Message Contents

All messages indicated shall use the same content as described in the default message content in TS 05.08 [20] clause 9 for R99 and in TS45.008 [30] clause 9 for Rel-4 and later releases, with the above exceptions.

8.2.3.1.4.2 Procedure

- 1) The SS activates cell 1 and 2 with T1 defined parameters in tables 8.2.3.1.4 and 8.2.3.1.5 and monitors cell 1 and 2 for random access requests from the UE.
- 2) The UE is switched on.
- 3) The SS and the UE shall perform a location registration procedure on cell 1.
- 4) After 45 s from the end of step 3, the parameters are changed as described for T2 in tables 8.2.3.1.4 and 8.2.3.1.5.
- 5) The SS waits for a location registration procedure from the UE. If the UE begins transmitting on cell 2 within 28 s then the number of successful tests is increased by one.
- 6) After 35 s from the beginning of T2, the parameters are changed as described for T1 in tables 8.2.3.1.4 and 8.2.3.1.5.
- 7) The SS and the UE shall perform a location registration procedure on cell 1.
- 8) After 45 s from the end of step 6, the parameters are changed as described for T2 in tables 8.2.3.1.4 and 8.2.3.1.5.

9) Repeat step 5) to 8) until the confidence level according to annex F.6.2 is achieved.

8.2.3.1.5 Test requirements

Table 8.2.3.1.4: Scenario 1: Cell re-selection UTRAN to GSM cell case (cell 1), test requirements

Parameter	Unit	Cell 1 (UTRA)	
		T1	T2
UTRA RF Channel Number		Channel 1	
CPICH_Ec/Ior	dB	-9.9	-10.1
PCCPCH_Ec/Ior	dB	-12	
SCH_Ec/Ior	dB	-12	
PICH_Ec/Ior	dB	-15	
OCNS_Ec/Ior	dB	-0.953	-0,928
\hat{I}_{or}/I_{oc}	dB	0.3	-5.3
I_{oc}	dBm/3.84 MHz	-70	
CPICH_Ec/Io (Note 1)	dB	-12.8	-16.5
CPICH_RSCP (Note1)	dBm	-79.6	-85.4
Propagation Condition		AWGN	
Cell_selection_and_reselection_quality_measure		CPICH E _c /N ₀	
Qqualmin	dB	-20	
Qrxlevmin	dBm	-115	
UE_TXPWR_MAX_RACH	dBm	21	
Qoffset _{1s,n}	dB	C1, C2: 0	
Qhyst1	dB	0	
Treselection	s	0	
Ssearch _{RAT}	dB	not sent	

Table 8.2.3.1.5: Scenario 1: Cell re-selection UTRAN to GSM cell case (cell 2), test requirements

Parameter	Unit	Cell 2 (GSM)	
		T1	T2
Absolute RF Channel Number		BCCH ARFCN of cell A as defined in the initial conditions in clause 26.6.5.1 of TS 51.010-1 [25] for the GSM band under test.	
RXLEV	dBm	-91	-74
RXLEV_ACCESS_MIN	dBm	-104	
MS_TXPWR_MAX_CCH	dBm	33	
FDD_Qmin	dB	-14	
Qsearch_I	-	always	

NOTE 1: CPICH_Ec/Io and CPICH_RSCP levels have been calculated from other parameters for information purposes. They are not settable parameters themselves.

For the test to pass, the total number of successful tests shall be at least 90% of the cases with a confidence level of 95%.

NOTE: If the above Test Requirement differs from the Minimum Requirement then the Test Tolerance applied for this test is non-zero. The Test Tolerance for this test is defined in clause F.2 and the explanation of how the Minimum Requirement has been relaxed by the Test Tolerance is given in clause F.4.

8.2.3.2 Scenario 2: Only UTRA level changed

8.2.3.2.1 Definition and applicability

The cell re-selection delay is defined as the time from a change of cell levels to the moment when this change makes the UE camp on a new cell and starts to send the RR Channel Request message for location update to the new cell.

The requirements and this test apply to the combined FDD and GSM UE.

8.2.3.2.2 Minimum requirement

The cell re-selection delay shall be less than $7.7 \text{ s} + T_{\text{BCCH}}$, where T_{BCCH} is the maximum time allowed to read BCCH data from GSM cell, see TS 05.08 [20] for R99 and TS 45.008 [30] for Rel-4 and later releases.

The rate of correct cell reselections observed during repeated tests shall be at least 90% with a confidence level of 95 %.

NOTE: The cell re-selection delay can be expressed as: $\text{Max}(3 * T_{\text{measureFDD}}, T_{\text{measureGSM}} + \text{DRX cycle length}) + T_{\text{BCCH}}$, where:

$T_{\text{measureFDD}}$	See table 4.1 in TS 25.133 [2] clause 4.2.2.
$T_{\text{measureGSM}}$	See table 4.1 in TS 25.133 [2] clause 4.2.2.
DRX cycle length	1.28s see Table A.4.7.A in TS 25.133 [2] clause A.4.3.2.
T_{BCCH}	Maximum time allowed to read BCCH data from GSM cell, see TS 05.08 [20] for R99 and TS 45.008 [30] for Rel-4 and later releases. According to [20] and [30], the maximum time allowed to read the BCCH data, when being synchronized to a BCCH carrier, is 1.9 s.

This gives a total of $7.68 \text{ s} + T_{\text{BCCH}}$, allow $7.7 \text{ s} + T_{\text{BCCH}}$ in the test case.

The normative reference for this requirement is TS 25.133 [2] clauses 4.2.2 and A.4.3.2.

8.2.3.2.3 Test purpose

To verify that the UE meets the minimum requirement.

8.2.3.2.4 Method of test

8.2.3.2.4.1 Initial conditions

Test environment: normal; see clauses G.2.1 and G.2.2.

Frequencies to be tested: mid range; see clause G.2.4.

This scenario implies the presence of 1 UTRAN serving cell, and 1 GSM cell to be re-selected, as given in tables 8.2.3.2.1 to 8.2.3.2.5. The UE is requested to monitor neighbouring cells on 1 UMTS carrier and 12 GSM cells. Cell 1 and cell 2 shall belong to different Location Areas.

Table 8.2.3.2.1: Scenario 2: General test parameters for UTRAN to GSM Cell Re-selection

Parameter		Unit	Value	Comment
Initial condition	Active cell		Cell1	
	Neighbour cell		Cell2	
Final condition	Active cell		Cell2	
HCS				Not used
DRX cycle length		s	1.28	
Monitored cell list size			12 GSM neighbours including the ARFCN of cell 2	NOTE: See Annex I for cell information
T1		s	45	
T2		s	12	

Table 8.2.3.2.2: Scenario 2: Test parameters for Cell re-selection UTRAN to GSM cell case (cell 1)

Parameter	Unit	Cell 1 (UTRA)	
		T1	T2
UTRA RF Channel Number		Channel 1	
CPICH_Ec/Ior	dB	-10	
PCCPCH_Ec/Ior	dB	-12	
SCH_Ec/Ior	dB	-12	
PICH_Ec/Ior	dB	-15	
OCNS_Ec/Ior	dB	-0.941	
\hat{I}_{or}/I_{oc}	dB	20	-9
I_{oc}	dBm/3.84 MHz	-81	
CPICH_Ec/Io	dB	-10.0	-19.5
CPICH_RSCP	dBm	-70	-100
Propagation Condition		AWGN	
Cell_selection_and_reselection_quality_measure		CPICH E _c /N ₀	
Qqualmin	dB	-20	
Qrxlevmin	dBm	-115	
UE_TXPWR_MAX_RACH	dBm	21	
Qoffset1 _{s,n}	dB	C1, C2: 0	
Qhyst1	dB	0	
Treselection	s	0	
Ssearch _{RAT}	dB	not sent	

Table 8.2.3.2.3: Scenario 2: Test parameters for Cell re-selection UTRAN to GSM cell case (cell 2)

Parameter	Unit	Cell 2 (GSM)	
		T1	T2
Absolute RF Channel Number		ARFCN 1	
RXLEV	dBm	-80	-80
RXLEV_ACCESS_MIN	dBm	-104	
MS_TXPWR_MAX_CCH	dBm	33	
Qsearch_I	-	always	

Specific 2 quarter Message Contents

All messages indicated shall use the same content as described in the default message content in TS 05.08 [20] clause 9 for R99 and in TS45.008 [30] clause 9 for Rel-4 and later releases, with the above exceptions.

8.2.3.2.4.2 Procedure

- 1) The SS activates cell 1 and 2 with T1 defined parameters in tables 8.2.3.2.4 and 8.2.3.2.5 and monitors cell 1 and 2 for random access requests from the UE.
- 2) The UE is switched on.
- 3) The SS and the UE shall perform a location registration procedure on cell 1.
- 4) After 45 s from the end of step 3, the parameters are changed as described for T2 in tables 8.2.3.2.4 and 8.2.3.2.5.
- 5) The SS waits for a location registration procedure from the UE. If the UE begins transmitting on cell 2 within 9.7 s then the number of successful tests is increased by one.
- 6) After 12 s from the beginning of T2, the parameters are changed as described for T1 in tables 8.2.3.2.4 and 8.2.3.2.5.
- 7) The SS and the UE shall perform a location registration procedure on cell 1.
- 8) After 45 s from the end of step 6, the parameters are changed as described for T2 in tables 8.2.3.2.4 and 8.2.3.2.5.

9) Repeat step 5) to 8) until the confidence level according to annex F.6.2 is achieved.

8.2.3.2.5 Test requirements

Table 8.2.3.2.4: Scenario 2: Cell re-selection UTRAN to GSM cell case (cell 1), test requirements

Parameter	Unit	Cell 1 (UTRA)	
		T1	T2
UTRA RF Channel Number		Channel 1	
CPICH_Ec/Ior	dB	-9.9	-10.1
PCCPCH_Ec/Ior	dB	-12	
SCH_Ec/Ior	dB	-12	
PICH_Ec/Ior	dB	-15	
OCNS_Ec/Ior	dB	-0.953	-0.941
\hat{I}_{or}/I_{oc}	dB	20.3	-9.3
I_{oc}	dBm/3.84 MHz	-81	
CPICH_Ec/Io (Note1)	dB	-9.9	-19.9
CPICH_RSCP (Note1)	dBm	-70.6	-100.4
Propagation Condition		AWGN	
Cell_selection_and_reselection_quality_measure		CPICH E_c/N_0	
Qqualmin	dB	-20	
Qrxlevmin	dBm	-115	
UE_TXPWR_MAX_RACH	dBm	21	
Qoffset1 _{s,n}	dB	C1, C2: 0	
Qhyst1	dB	0	
Treselection	s	0	
Ssearch _{RAT}	dB	not sent	

Table 8.2.3.2.5: Scenario 2: Cell re-selection UTRAN to GSM cell case (cell 2), test requirements

Parameter	Unit	Cell 2 (GSM)	
		T1	T2
Absolute RF Channel Number		BCCH ARFCN of cell A as defined in the initial conditions in clause 26.6.5.1 of TS 51.010-1 [25] for the GSM band under test.	
RXLEV	dBm	-81	-79
RXLEV_ACCESS_MIN	dBm	-104	
MS_TXPWR_MAX_CCH	dBm	33	
Qsearch_I	-	always	

NOTE 1: CPICH_Ec/Io and CPICH_RSCP levels have been calculated from other parameters for information purposes. They are not settable parameters themselves.

For the test to pass, the total number of successful tests shall be at least 90% of the cases with a confidence level of 95 %.

NOTE: If the above Test Requirement differs from the Minimum Requirement then the Test Tolerance applied for this test is non-zero. The Test Tolerance for this test is defined in clause F.2 and the explanation of how the Minimum Requirement has been relaxed by the Test Tolerance is given in clause F.4.

8.2.3.3 Scenario 3: HCS with only UTRA level changed

8.2.3.3.1 Definition and applicability

The cell re-selection delay is defined as the time from a change of cell levels to the moment when this change makes the UE camp on a new cell and starts to send the RR Channel Request message for location update to the new cell.

The requirements and this test apply to Release 6 and later releases for the combined FDD and GSM UE.

8.2.3.3.2 Minimum requirement

The cell re-selection delay shall be less than $37.7 \text{ s} + T_{\text{BCCH}}$, where T_{BCCH} is the maximum time allowed to read BCCH data from GSM cell, see TS 45.008 [30].

The rate of correct cell reselections observed during repeated tests shall be at least 90% with a confidence level of 95 %.

NOTE: The cell re-selection delay can be expressed as: $30\text{ s} + T_{\text{measureGSM}} + \text{DRX cycle length} + T_{\text{BCCH}}$, where:

$T_{\text{measureFDD}}$	See Table 4.1 in TS 25.133 [2] clause 4.2.2.
$T_{\text{measureGSM}}$	See Table 4.1 in TS 25.133 [2] clause 4.2.2.
DRX cycle length	1.28s see Table A.4.7.D in TS 25.133 [2] clause A.4.3.3.
T_{BCCH}	Maximum time allowed to read BCCH data from GSM cell, see TS 45.008 [30]. According to [20] and [30], the maximum time allowed to read the BCCH data, when being synchronized to a BCCH carrier, is 1.9 s.

This gives a total of $37.68\text{ s} + T_{\text{BCCH}}$, allow $37.7\text{ s} + T_{\text{BCCH}}$ in the test case.

The normative reference for this requirement is TS 25.133 [2] clauses 4.2.2 and A.4.3.3.

8.2.3.3.3 Test purpose

To verify that the UE meets the minimum requirement.

8.2.3.3.4 Method of test

8.2.3.3.4.1 Initial conditions

Test environment: normal; see clauses G.2.1 and G.2.2.

Frequencies to be tested: mid range; see clause G.2.4.

This scenario implies the presence of 1 UTRAN serving cell, and 1 GSM cell to be re-selected, as given in tables 8.2.3.3.1 to 8.2.3.3.5. The UE is requested to monitor neighbouring cells on 1 UMTS carrier and 12 GSM cells. Cell 1 and cell 2 shall belong to different Location Areas.

Table 8.2.3.3.1: Scenario 3: General test parameters for UTRAN to GSM Cell Re-selection

Parameter		Unit	Value	Comment
Initial condition	Active cell		Cell1	
	Neighbour cell		Cell2	
Final condition	Active cell		Cell2	
HCS				Used
DRX cycle length		s	1.28	
Monitored cell list size			12 GSM neighbours including the ARFCN of cell 2	NOTE: See Annex I for cell information
T1		s	45	
T2		s	45	

Table 8.2.3.3.2: Scenario 3: Test parameters for Cell re-selection UTRAN to GSM cell case (cell 1)

Parameter	Unit	Cell 1 (UTRA)	
		T1	T2
UTRA RF Channel Number		Channel 1	
CPICH_Ec/Ior	dB	-10	
PCCPCH_Ec/Ior	dB	-12	
SCH_Ec/Ior	dB	-12	
PICH_Ec/Ior	dB	-15	
OCNS_Ec/Ior	dB	-0.941	
\hat{I}_{or}/I_{oc}	dB	30	10
I_{oc}	dBm/3.84 MHz	-100	
CPICH_Ec/Io	dB	-10.0	-10.4
CPICH_RSCP	dBm	-80	-100
Propagation Condition		AWGN	
Cell_selection_and_reselection_quality_measure		CPICH E _c /N ₀	
Qqualmin	dB	-20	
Qrxlevmin	dBm	-115	
UE_TXPWR_MAX_RACH	dBm	21	
Qoffset1 _{s,n}	dB	C1, C2: 0	
Qhyst1	dB	0	
Treselection	s	0	
Ssearch _{RAT}	dB	0	
SHCS, _{RAT} m	dB	25	
S _{limit,SearchRAT}	dB	0	
Penalty_time	s	0 (default value)	
HCS_P _{RIO}		0 (default value)	
Qhcs		0 (default value)	
T _{C_{max}}	s	not used (default value)	

Table 8.2.3.3.3: Scenario 3: Test parameters for Cell re-selection UTRAN to GSM cell case (cell 2)

Parameter	Unit	Cell 2 (GSM)	
		T1	T2
Absolute RF Channel Number		ARFCN 1	
RXLEV	dBm	-80	-80
RXLEV_ACCESS_MIN	dBm	-104	
MS_TXPWR_MAX_CCH	dBm	33	
Qsearch_I	-	always	

Specific 2 quarter Message Contents

All messages indicated shall use the same content as described in the default message content in TS45.008 [30] clause 9, with the above exceptions.

8.2.3.3.4.2 Procedure

- 1) The SS activates cell 1 and 2 with T1 defined parameters in tables 8.2.3.3.4 and 8.2.3.3.5 and monitors cell 1 and 2 for random access requests from the UE.
- 2) The UE is switched on.
- 3) The SS and the UE shall perform a location registration procedure on cell 1.
- 4) After 45 s from the end of step 3, the parameters are changed as described for T2 in tables 8.2.3.3.4 and 8.2.3.3.5.
- 5) The SS waits for a location registration procedure from the UE. If the UE begins transmitting on cell 2 within 39.7 s then the number of successful tests is increased by one.

- 6) After 45 s from the beginning of T2, the parameters are changed as described for T1 in tables 8.2.3.3.4 and 8.2.3.3.5.
- 7) The SS and the UE shall perform a location registration procedure on cell 1.
- 8) After 45 s from the end of step 6, the parameters are changed as described for T2 in tables 8.2.3.3.4 and 8.2.3.3.5.
- 9) Repeat step 5) to 8) until the confidence level according to annex F.6.2 is achieved.

Specific Message Contents

All messages indicated above shall use the same content as described in the default message content in clause 6.1.0b of 34.108 [3], with the above and the following exceptions:

SYSTEM INFORMATION BLOCK TYPE3

Information Element	Value
HCS Serving Cell Information	
-HCS PRIO	0
-Qhcs	0
-T _{CRmax}	not used

SYSTEM INFORMATION BLOCK TYPE11

Information Element	Value
HCS neighbouring Cell Information	
-HCS PRIO	0
-Qhcs	0
-HCS Cell RE-selection Information	
-Penalty_time	0

8.2.3.3.5 Test requirements

Table 8.2.3.3.4: Scenario 3: Cell re-selection UTRAN to GSM cell case (cell 1), test requirements

Parameter	Unit	Cell 1 (UTRA)	
		T1	T2
UTRA RF Channel Number		Channel 1	
CPICH_Ec/Ior	dB	-9.9	-10.1
PCCPCH_Ec/Ior	dB	-12	
SCH_Ec/Ior	dB	-12	
PICH_Ec/Ior	dB	-15	
OCNS_Ec/Ior	dB	-0.953	-0.928
\hat{I}_{or}/I_{oc}	dB	30.3	9.7
I_{oc}	dBm/3.84 MHz	-100	
CPICH_Ec/Io (Note1)	dB	-9.9	-10.5
CPICH_RSCP (Note1)	dBm	-79.6	-100.4
Propagation Condition		AWGN	
Cell_selection_and_reselection_quality_measure		CPICH E _c /N ₀	
Qualmin	dB	-20	
Qrxlevmin	dBm	-115	
UE_TXPWR_MAX_RACH	dBm	21	
Qoffset1 _{s,n}	dB	C1, C2: 0	
Qhyst1	dB	0	
Treselection	s	0	
Ssearch _{RAT}	dB	0	
SHCS _{RATm}	dB	25	
S _{limit,SearchRAT}	dB	0	
Penalty_time	s	0 (default value)	
HCS_PRIO		0 (default value)	
Qhcs		0 (default value)	
T _{Cmax}	s	not used (default value)	

Table 8.2.3.3.5: Scenario 3: Cell re-selection UTRAN to GSM cell case (cell 2), test requirements

Parameter	Unit	Cell 2 (GSM)	
		T1	T2
Absolute RF Channel Number		BCCH ARFCN of cell A as defined in the initial conditions in clause 26.6.5.1 of TS 51.010-1 [25] for the GSM band under test.	
RXLEV	dBm	-81	-79
RXLEV_ACCESS_MIN	dBm	-104	
MS_TXPWR_MAX_CCH	dBm	33	
Qsearch_I	-	always	

NOTE 1: CPICH_Ec/Io and CPICH_RSCP levels have been calculated from other parameters for information purposes. They are not settable parameters themselves.

For the test to pass, the total number of successful tests shall be at least 90% of the cases with a confidence level of 95 %.

NOTE: If the above Test Requirement differs from the Minimum Requirement then the Test Tolerance applied for this test is non-zero. The Test Tolerance for this test is defined in clause F.2 and the explanation of how the Minimum Requirement has been relaxed by the Test Tolerance is given in clause F.4.

8.2.4 FDD/TDD Cell Re-selection

8.2.4.1 Definition and applicability

The cell re-selection delay is defined as the time from the cell quality levels change to the moment when this change makes the UE reselect a better ranked cell, and starts to send the RRC CONNECTION REQUEST message to perform a Location Registration on the new cell.

This test is for the case where the UE camps on an FDD cell and reselects to a TDD cell.

The requirements and this test apply to UEs supporting both FDD and TDD.

8.2.4.1.1 3.84 Mcps TDD Option

The cell re-selection delay is defined as the time from the cell quality levels change to the moment when this change makes the UE reselect a better ranked cell, and starts to send the RRC CONNECTION REQUEST message to perform a Location Registration on the new cell.

This test is for the case where the UE camps on an FDD cell and reselects to a 3.84Mcps TDD cell.

The requirements and this test apply to UEs supporting both FDD and 3.84Mcps TDD.

8.2.4.1.2 1.28 Mcps TDD Option

The cell re-selection delay is defined as the time from the cell quality levels change to the moment when this change makes the UE reselect a better ranked cell, and starts to send SYNCH-UL sequence in the UpPTS for sending RRC CONNECTION REQUEST message to perform a Location Registration on the new cell.

This test is for the case where the UE camps on a FDD cell and reselects to a 1.28Mcps TDD cell.

The requirements and this test apply to UEs supporting both FDD and 1.28Mcps TDD.

8.2.4.2 Minimum requirement

The cell re-selection delay shall be less than 8 s with a DRX cycle length of 1,28 s. This shall be verified in more than 90 % of the cases with a confidence level of 95 %.

The normative reference for this requirement is TS 25.133 [2] clauses 4.2.2.4 and A.4.4.

8.2.4.3 Test purpose

To verify that the UE meets the minimum requirement for the case where the UE camps on an FDD cell and reselects to a TDD cell.

8.2.4.4 Method of test

8.2.4.4.1 Initial conditions

8.2.4.4.1.1 3.84 Mcps TDD Option

This scenario implies the presence of UTRA FDD and 1 3.84Mcps TDD cell as given in tables 8.2.4.1, 8.2.4.2 and 8.2.4.3. The maximum repetition period of the relevant system information blocks that need to be received by the UE to camp on a cell shall be 1280 ms.

Cell 1 and cell 2 shall belong to different Location Areas.

Table 8.2.4.1: General test parameters for FDD/TDD Cell Re-selection

Parameter		Unit	Value	Comment
Initial condition	Active cell		Cell1	FDD cell
	Neighbour cells		Cell2	TDD cell
Final condition	Active cell		Cell2	TDD cell
UE_TXPWR_MAX_RACH		dBm	21	The value shall be used for all cells in the test.
Access Service Class (ASC#0) - Persistence value			1	Selected so that no additional delay is caused by the random access procedure. The value shall be used for all cells in the test.
HCS				Not used
DRX cycle length		S	1.28	The value shall be used for all cells in the test.
T1		S	15	
T2		S	15	

Table 8.2.4.2: Cell 1 specific test parameters for FDD/TDD Cell Re-selection

Parameter	Unit	Cell 1	
		T1	T2
UTRA RF Channel Number		Channel 1	
CPICH_Ec/I _{or}	dB	-10	
P-CCPCH_Ec/I _{or}	dB	-12	
SCH_Ec/I _{or}	dB	-12	
PICH_Ec/I _{or}	dB	-15	
OCNS_Ec/I _{or}	dB	-0.941	
\hat{I}_{or}/I_{oc}	dB	9	3
I_{oc}	dBm / 3.84 MHz	-70	
CPICH_RSCP	dBm	-71	-77
Propagation Condition		AWGN	
Cell_selection_and_reselection_quality_measure		CPICH_Ec/No	
Qrxlevmin	dBm	-115	
Qoffset1 _{s,n}	dB	0	
Qhyst1	dB	0	
Treselection	s	0	
Sintrasearch	dB	not sent	
Sintersearch	dB	not sent	

Table 8.2.4.3: Cell 2 specific test parameters for FDD/TDD Cell Re-selection

Parameter	Unit	Cell 2			
		0		8	
DL timeslot number		T1	T2	T1	T2
UTRA RF Channel Number		Channel 2			
P-CCPCH_Ec/Ior	dB	-3		n.a.	
PICH_Ec/Ior	dB	n.a.		-3	
SCH_Ec/Ior	dB	-9			
SCH_t_offset	dB	10			
OCNS_Ec/Ior	dB	-3.12			
\hat{I}_{or}/I_{oc}	dB	-4	2	-4	2
P-CCPCH RSCP	dBm	-77	-71	n.a.	n.a.
I_{oc}	dBm/ 3,84 MHz	-70			
Propagation Condition		AWGN			
Qrxlevmin	dBm	-103			
Qoffset2_s,n	dB	0			
Qhyst2	dB	0			
Treselection	s	0			
Sintrasearch	dB	not sent			
Sintersearch	dB	not sent			
NOTE:	that the transmit energy per PN chip for the SCH is averaged over the 256 chip duration when the SCH is present in the time slot.				

8.2.4.4.1.2 1.28Mcps TDD Option

This scenario implies the presence of UTRA FDD and 1 1.28Mcps TDD cell as given in tables 8.2.4.1A, 8.2.4.2A and 8.2.4.3A. The maximum repetition period of the relevant system information blocks that need to be received by the UE to camp on a cell shall be 1280 ms.

Cell 1 and cell 2 shall belong to different Location Areas.

Table 8.2.4.1A: General test parameters for FDD/TDD cell re-selection

Parameter		Unit	Value	Comment
Initial condition	Active cell		Cell1	FDD cell
	Neighbour cells		Cell2	TDD cell
Final condition	Active cell		Cell2	TDD cell
UE_TXPWR_MAX_RACH		dBm	21	The value shall be used for all cells in the test.
Access Service Class (ASC#0) - Persistence value			1	Selected so that no additional delay is caused by the random access procedure. The value shall be used for all cells in the test.
HCS				Not used
DRX cycle length		s	1,28	The value shall be used for all cells in the test.
T1		s	15	
T2		s	15	

Table 8.2.4.2A: FDD/TDD cell re-selection

Parameter	Unit	Cell 1	
		T1	T2
UTRA RF Channel Number		Channel 1	
CPICH_Ec/lor	dB	-10	
P-CCPCH_Ec/lor	dB	-12	
SCH_Ec/lor	dB	-12	
PICH_Ec/lor	dB	-15	
OCNS_Ec/lor	dB	-0.941	
\hat{I}_{or}/I_{oc}	dB	9	3
I_{oc}	dBm / 3.84 MHz	-70	
CPICH_RSCP	dBm	-71	-77
Propagation Condition		AWGN	
Cell_selection_and_reselection_quality_measure		CPICH_Ec/No	
Qrxlevmin	dBm	-115	
Qoffset1 _{s,n}	dB	0	
Qhyst1	dB	0	
Treselection	s	0	
Sintrasearch	dB	not sent	
Sintersearch	dB	not sent	

Table 8.2.4.3A: Cell 2 specific test parameters for FDD/TDD Cell Re-selection

Parameter	Unit	Cell 2			
		0		DwPTS	
DL timeslot number		T1	T2	T1	T2
UTRA RF Channel Number		Channel 2			
P-CCPCH_Ec/lor	dB	-3			
DwPCH_Ec/lor	dB	0			
OCNS_Ec/lor	dB	-3			
\hat{I}_{or}/I_{oc}	dB	-4	2	-4	2
P-CCPCH RSCP	dBm	-77	-71		
I_{oc}	dBm/ 1.28 MHz	-70			
Propagation Condition		AWGN			
Qrxlevmin	dBm	-103			
Qoffset1 _{s,n}	dB	0			
Qhyst1	dB	0			
Treselection	s	0			
Sintrasearch	dB	not sent			
Sintersearch	dB	not sent			

8.2.4.4.2 Procedures

- The SS activates cell 1 and cell 2 with T1 defined parameters and monitors them for random access requests from the UE.
- The UE is switched on.
- The SS waits for random access requests from the UE.

- d) After 15 s, the parameters are changed as described for T2.
- e) The SS waits for random access request from the UE.
- f) After another 15 s, the parameters are changed as described for T1.
- g) The SS waits for random access requests from the UE.
- h) Repeat step d) to g) until the confidence level according to annex F.6.2 is achieved.

8.2.4.5 Test requirements

- 1) In step c), after the UE has responded on cell 1, it shall not respond on any other cell (cell selection).
- 2) In step e), the UE shall respond on cell 2 within 8 s in more than 90 % of the cases.
- 3) In step g), the UE shall respond on cell 1.

NOTE: If the above Test Requirement differs from the Minimum Requirement then the Test Tolerance applied for this test is non-zero. The Test Tolerance for this test is defined in clause F.2 and the explanation of how the Minimum Requirement has been relaxed by the Test Tolerance is given in clause F.4.

8.3 UTRAN Connected Mode Mobility

8.3.1 FDD/FDD Soft Handover

8.3.1.1 Definition and applicability

The active set update delay of the UE is defined as the time from the end of the last TTI containing an RRC message implying soft handover to the switch off of the old downlink DPCH.

The requirements and this test apply to the FDD UE.

8.3.1.2 Minimum requirement

The active set update delay is defined as the time from when the UE has received the ACTIVE SET UPDATE message from UTRAN, or at the time stated through the activation time when to perform the active set update, to the time when the UE successfully uses the set of radio links stated in that message for power control.

The active set update delay is depending on the number of known cells referred to in the ACTIVE SET UPDATE message. A cell is known if it has been measured by the UE during the last 5 seconds and the SFN of the cell has been decoded by the UE.

And the phase reference is the primary CPICH.

The active set update delay shall be less than $50+10*KC+100*OC$ ms, where

KC is the number of known cells in the active set update message.

OC is the number of cells that are not known in the active set update message.

If the UE have radio links in the active set that it can not use for data detection (due to low signal level), the UE shall at least every 150 ms search for the radio link.

The normative reference for this requirement is TS 25.133 [2] clauses 5.1.2 and A.5.1.1. The active set update delay shall be less than 60 ms in CELL_DCH state when using test parameters as given in table 8.3.1.1.1.

8.3.1.3 Test purpose

To verify that the UE meets the minimum requirement.

8.3.1.4 Method of test

8.3.1.4.1 Initial conditions

Test environment: normal; see clauses G.2.1 and G.2.2.

Frequencies to be tested: mid range; see clause G.2.4.

The test parameters are given in table 8.3.1.1.1 and 8.3.1.1.2 below. In the measurement control information it is indicated to the UE that event-triggered reporting with Event 1A shall be used, and that CPICH Ec/Io and SFN-CFN observed time difference shall be reported together with Event 1A. The test consists of six successive time periods, with a time duration of T1, T2, T3, T4, T5 and T6 respectively. At the start of time duration T1, the UE may not have any timing information of cell 2.

Table 8.3.1.1.1: General test parameters for Soft handover

Parameter	Unit	Value	Comment
DCH parameters		DL Reference Measurement Channel 12.2 kbps and UL Auxiliary Measurement Channel 12.2 kbps	DL Measurement Channel as specified in clause C.3.1 UL Auxiliary Measurement Channel as specified in clause C.6.3
Power Control		On	
Target quality value on DTCH	BLER	0.01	
Initial conditions	Active cell	Cell 1	
	Neighbouring cell	Cell 2	
Final condition	Active cell	Cell 2	
Reporting range	dB	3	Applicable for event 1A and 1B
Hysteresis	dB	0	
W		1	Applicable for event 1A and 1B
Reporting deactivation threshold		0	Applicable for event 1A
Time to Trigger	ms	0	
Filter coefficient		0	
T0	s	10	
T1	s	5	
T2	s	3	
T3	s	0.5	
T4	ms	60	This is the requirement on active set update delay, see clause 8.3.1.2, where KC=1 and OC=0.
T5	ms	20	
T6	s	2	

Table 8.3.1.1.1A: Cell specific test parameters for Soft handover (T0)

Parameter	Unit	Cell 1	Cell 2
		T0	T0
CPICH_Ec/Ior	dB	-10	-10
PCCPCH_Ec/Ior	dB	-12	-12
SCH_Ec/Ior	dB	-12	-12
PICH_Ec/Ior	dB	-15	-15
DPCH_Ec/Ior	dB	Note1	N/A
OCNS_Ec/Ior	dB	Note2	-0.94
\hat{I}_{or}/I_{oc}	dB	0	-Inf
I_{oc}	dBm/ 3.84 MHz	-70	
CPICH_Ec/Io	dB	-13	-Inf
Propagation Condition		AWGN	

NOTE 1: The DPCH level is controlled by the power control loop.
NOTE 2: The power of the OCNS channel that is added shall make the total power from the cell to be equal to I_{or}.

Table 8.3.1.1.2: Cell specific test parameters for Soft handover

Parameter	Unit	Cell 1						Cell 2					
		T1	T2	T3	T4	T5	T6	T1	T2	T3	T4	T5	T6
CPICH_Ec/I _{or}	dB	-10						-10					
PCCPCH_Ec/I _{or}	dB	-12						-12					
SCH_Ec/I _{or}	dB	-12						-12					
PICH_Ec/I _{or}	dB	-15						-15					
DPCH_Ec/I _{or}	dB	Note1	Note1	Note1	N/A	N/A	N/A	N/A	Note3	Note1	Note1	Note1	
OCNS_Ec/I _{or}	dB	Note2	Note2	Note2	-0.94	-0.94	-0.94	-0.94	Note2	Note2	Note2	Note2	
\hat{I}_{or}/I_{oc}	dB	0	2.91	2.91	2.91	2.91	-Inf	2.91	2.91	2.91	2.91	2.91	
I_{oc}	dBm/3.84 MHz	-70											
CPICH_Ec/I _o	dB	-13	-14	-14	-14	-14	-Inf	-14	-14	-14	-14	-14	
Propagation Condition		AWGN											
Relative delay of paths received from cell 2 with respect to cell 1	chips	{-148 ... 148} Note 4											
NOTE 1: The DPCH level is controlled by the power control loop													
NOTE 2: The power of the OCNS channel that is added shall make the total power from the cell to be equal to I_{or}													
NOTE 3: The DPCH level is controlled by the power control loop. The initial power shall be set equal to the DPCH_Ec/I _{or} of Cell 1 at the end of T2.													
NOTE 4: The relative delay of the path from cell 2 with respect to cell 1 shall always be within ±148 chip.													

8.3.1.4.2 Procedure

- 1) The RF parameters are set up according to T0 in table 8.3.1.1.2A.
- 2) The UE is switched on.
- 3) A call is set up according to the test procedure specified in TS 34.108 [3] subclause 7.3.4 without Compressed mode parameters and test loop mode 2 is used. See TS 34.109 [4] for details regarding loopback test. 10 seconds after call setup is completed, the power settings will be set according to T1.
- 4) SS shall transmit a MEASUREMENT CONTROL message.
- 5) 5 seconds after power settings have been changed to T1, the SS shall switch the power settings from T1 to T2.
- 6) UE shall transmit a MEASUREMENT REPORT message triggered by event 1A containing the CFN-SFN observed time difference between cell 1 and cell 2.
- 7) At the beginning of T3 the downlink DPCH of cell 2 shall be activated.
- 8) SS shall send an ACTIVE SET UPDATE message with activation time "now ", adding cell 2 to the active set. The start of T4 is defined as the end of the last TTI containing the ACTIVE SET UPDATE message.
- 9) At the beginning of T5 the DPCH from cell 1 shall be switched off.
- 10) The UE downlink BLER shall be measured during time period T6.
- 11) If the UE sends a Cell Update message with the cell update cause as radio link failure, the SS shall re-establish the radio link on the first cell and shall continue the test. The BLER values measured for this loop will be discarded while maintaining the BLER values measured for the previous loops,

NOTE: The Radio link could be setup either by switching off the UE and restarting the test or by re-establishing the Radio Link directly using additional signalling procedures. However this decision is left upto the the SS manufacturer

- 12) After step 10 has completed, the DPCH from cell 1 shall be switched on. The SS shall send ACTIVE SET UPDATE message with activation time "now " to remove cell 2 from the active set. The RF parameters will be set according to T1.
- 13) BLER is measured during concatenated time periods T6. Repeat step 4-12 until the confidence level for BLER is achieved. This is defined in annex F.6.1.10.

Specific Message Contents

All messages indicated above shall use the same content as described in the default message content in clause 9 of 34.108 [3], with the following exceptions:

Contents of RRC CONNECTION SETUP message: UM (step 3):

Information Element	Value/remark	Version
Added or Reconfigured DL TrCH information list	1	
- Added or Reconfigured DL TrCH information		
- Downlink transport channel type	DCH	
- DL Transport channel identity	10	
- CHOICE DL parameters	Same as UL	
- Uplink transport channel type	DCH	
- UL TrCH Identity	5	
- DCH quality target	Not Present	

MEASUREMENT CONTROL message (step 4):

Information Element/Group name	Value/Remark
Message Type (10.2.17)	
UE information elements -RRC transaction identifier -Integrity check info -message authentication code -RRC message sequence number	0 SS calculates the value of MAC-I for this message and writes to this IE. The first/ leftmost bit of the bit string contains the most significant bit of the MAC-I. SS provides the value of this IE, from its internal counter.
Measurement Information elements -Measurement Identity -Measurement Command (10.3.7.46) -Measurement Reporting Mode (10.3.7.49) -Measurement Report Transfer Mode -Periodical Reporting / Event Trigger Reporting Mode -Additional measurements list (10.3.7.1)	1 Modify AM RLC Event trigger Not Present
-CHOICE <i>Measurement type</i> -Intra-frequency measurement (10.3.7.36) -Intra-frequency measurement objects list (10.3.7.33) -Intra-frequency measurement quantity (10.3.7.38) -Filter coefficient (10.3.7.9) -CHOICE mode -Measurement quantity -Intra-frequency reporting quantity (10.3.7.41)	Intra-frequency measurement Not Present 0 FDD CPICH_Ec/N0
-Reporting quantities for active set cells (10.3.7.5) -Cell synchronisation information reporting indicator -Cell Identity reporting indicator -CHOICE mode -CPICH Ec/N0 reporting indicator -CPICH RSCP reporting indicator -Pathloss reporting indicator	TRUE (Note 1) TRUE FDD TRUE TRUE FALSE
-Reporting quantities for monitored set cells (10.3.7.5) -Cell synchronisation information reporting indicator -Cell Identity reporting indicator -CHOICE mode -CPICH Ec/N0 reporting indicator -CPICH RSCP reporting indicator -Pathloss reporting indicator	TRUE (Note 1) TRUE FDD TRUE TRUE FALSE
-Reporting quantities for detected set cells (10.3.7.5)	Not Present
-Reporting cell status (10.3.7.61) -Measurement validity (10.3.7.51) -CHOICE report criteria -Intra-frequency measurement reporting criteria (10.3.7.39) -Parameters required for each event	Not Present Not Present Intra-frequency measurement reporting criteria 2
-Intra-frequency event identity -Triggering condition 2 -Reporting Range Constant -Cells forbidden to affect Reporting Range -W -Hysteresis -Threshold used frequency -Reporting deactivation threshold -Replacement activation threshold -Time to trigger -Amount of reporting -Reporting interval -Reporting cell status	Event 1A Monitored set cells 3 dB Not Present 1.0 0 dB Not Present 0 Not Present 0 ms Infinity 0 ms (Note 2)
- CHOICE reported cell - Maximum number of reported cells	Report cell within active set and/or monitored set cells on used frequency 3
-Intra-frequency event identity -Triggering condition 1 -Reporting Range Constant	Event 1B Active set cells 3 dB

Information Element/Group name	Value/Remark
-Cells forbidden to affect Reporting Range	Not Present
-W	1.0
-Hysteresis	0 dB
-Threshold used frequency	Not Present
-Reporting deactivation threshold	Not Present
-Replacement activation threshold	Not Present
-Time to trigger	0 ms
-Amount of reporting	Not Present
-Reporting interval	Not Present
-Reporting cell status	
- CHOICE reported cell	Report cell within active set and/or monitored set cells on used frequency
- Maximum number of reported cells	3
Physical channel information elements	
-DPCH compressed mode status info (10.3.6.34)	Not Present
NOTE 1: The SFN-CFN observed time difference is calculated from the OFF and Tm parameters contained in the IE "Cell synchronisation information ", TS 25.331, clause 10.3.7.6. According to TS 25.331, 8.6.7.7, this IE is included in MEASUREMENT REPORT if IE "Cell synchronisation information reporting indicator" in IE "Cell reporting quantities" TS 25.331, clause 10.3.7.5 is set to TRUE in MEASUREMENT CONTROL.	
NOTE 2: Reporting interval = 0 ms means no periodical reporting	

ACTIVE SET UPDATE message (step 8):

Information Element/Group name	Type and reference	Value/Remark	Version
Message Type	Message Type		
UE information elements			
-RRC transaction identifier	RRC transaction identifier 10.3.3.36	0	
-Integrity check info	Integrity check info 10.3.3.16		
-message authentication code		SS calculates the value of MAC-I for this message and writes to this IE. The first/leftmost bit of the bit string contains the most significant bit of the MAC-I.	
-RRC message sequence number		SS provides the value of this IE, from its internal counter.	
-Integrity protection mode info	Integrity protection mode info 10.3.3.19	Not Present	
-Ciphering mode info	Ciphering mode info 10.3.3.5	Not Present	
-Activation time	Activation time 10.3.3.1	"now".	
-New U-RNTI	U-RNTI 10.3.3.47	Not Present	
CN information elements			
-CN Information info	CN Information info 10.3.1.3	Not Present	
Phy CH information elements			
Uplink radio resources			
-Maximum allowed UL TX power	Maximum allowed UL TX power 10.3.6.39	33 dBm	
Downlink radio resources			
-Radio link addition information	Radio link addition information 10.3.6.68	Radio link addition information required for each RL to add	
-Primary CPICH info	Primary CPICH info 10.3.6.60	Same as defined in cell2	

Information Element/Group name	Type and reference	Value/Remark	Version
-D7ownlink DPCH info for each RL	Downlink DPCH info for each RL 10.3.6.21		
-CHOICE mode			
-FDD			
-Primary CPICH usage for channel estimation	Primary CPICH usage for channel estimation 10.3.6.62	Primary CPICH may be used	
-DPCH frame offset	Integer(0..38144 by step of 256)	This should be reflected by the IE" Cell synchronisation information" in received MEASUREMENT REPORT message	
-Secondary CPICH info	Secondary CPICH info 10.3.6.73	Not Present	
-DL channelisation code			
-Secondary scrambling code	Secondary scrambling code 10.3.6.74	Not Present	
-Spreading factor	Integer(4, 8, 16, 32, 64, 128, 256, 512)	128	
-Code number	Integer(0..Spreading factor - 1)	96	
-Scrambling code change	Enumerated (code change, no code change)	No code change	
-TPC combination index	TPC combination index 10.3.6.85	0	
-SSDT Cell Identity	SSDT Cell Identity 10.3.6.76	Not Present	R99 and Rel-4 only
-Closed loop timing adjustment mode	Integer(1, 2)	Not Present	
-TFCI combining indicator	TFCI combining indicator 10.3.6.81	FALSE	
-SCCPCH Information for FACH	SCCPCH Information for FACH 10.3.6.70	Not Present	
Radio link removal information		Radio link removal information required for each RL to remove	
-Radio link removal information	Radio link removal information 10.3.6.69	Not Present	
-TX Diversity Mode	TX Diversity Mode 10.3.6.86	None	
-SSDT information	SSDT information 10.3.6.77	Not Present	R99 and Rel-4 only

ACTIVESET UPDATE message (Radio link removal information)

Information Element/Group name	Value/Remark	Version
Message Type (10.2.17)		
UE information elements - RRC transaction identifier - Integrity check info - message authentication code - RRC message sequence number - Activation time - New U-RNTI	0 SS calculates the value of MAC-I for this message and writes to this IE. The first/ leftmost bit of the bit string contains the most significant bit of the MAC-I. SS provides the value of this IE, from its internal counter. "now". Not Present	
CN information elements - CN Information info	Not Present	
Phy CH information elements Uplink radio resources - Maximum allowed UL TX power	33 dBm	
Downlink radio resources - Radio link addition information - Radio link removal information - Primary CPICH info - Primary scrambling code - TX Diversity Mode - SSdT information	Not Present 1 Same as defined in cell2 Not Present Not Present	
		R99 and Rel-4 only

8.3.1.5 Test requirements

Table 8.3.1.1.2A: Cell specific test parameters for Soft handover (T0)

Parameter	Unit	Cell 1	Cell 2
		T0	T0
CPICH_Ec/Ior	dB	-9.3	-9.3
PCCPCH_Ec/Ior	dB	-11.3	-11.3
SCH_Ec/Ior	dB	-11.3	-11.3
PICH_Ec/Ior	dB	-14.3	-14.3
DPCH_Ec/Ior	dB	Note1	N/A
OCNS_Ec/Ior	dB	Note2	-1.13
\hat{I}_{or}/I_{oc}	dB	0	-Inf
I_{oc}	dBm/ 3.84 MHz	-70	
CPICH_Ec/Io	dB	-12.3	-Inf
Propagation Condition		AWGN	
NOTE 1: The DPCH level is controlled by the power control loop.			
NOTE 2: The power of the OCNS channel that is added shall make the total power from the cell to be equal to I_{or} .			

Table 8.3.1.1.3: Cell specific test parameters for Soft handover

Parameter	Unit	Cell 1						Cell 2					
		T1	T2	T3	T4	T5	T6	T1	T2	T3	T4	T5	T6
CPICH_Ec/I _{or}	dB	-9.3						-9.3					
PCCPCH_Ec/I _{or}	dB	-11.3						-11.3					
SCH_Ec/I _{or}	dB	-11.3						-11.3					
PICH_Ec/I _{or}	dB	-14.3						-14.3					
DPCH_Ec/I _{or}	dB	Note1	Note1	Note1	N/A	N/A	N/A	N/A	Note3	Note1	Note1		
OCNS		Note2	Note2	Note2	-1.13	-1.13	-1.13	-1.13	Note2	Note2	Note2		
\hat{I}_{or}/I_{oc}	dB	0	2.91	2.91	2.91	2.91	-Inf	2.91	2.91	2.91	2.91		
I_{oc}	dBm/3 .84 MHz	-70											
CPICH_Ec/I _o	dB	-12.3	-13.3	-13.3	-13.3	-13.3	-Inf	-13.3	-13.3	-13.3	-13.3		
Propagation Condition		AWGN											
Relative delay of paths received from cell 2 with respect to cell 1	chips	{-147.5 ... 147.5} Note 4											
NOTE 1:	The DPCH level is controlled by the power control loop												
NOTE 2:	The power of the OCNS channel that is added shall make the total power from the cell to be equal to I_{or}												
NOTE 3:	The DPCH level is controlled by the power control loop. The initial power shall be set equal to the DPCH_Ec/I _{or} of Cell 1 at the end of T2.												
NOTE 4:	The relative delay of the path from cell 2 with respect to cell 1 shall always be within -147.5 ... 147.5 chip.												

The average measured quality on the DTCH of the UE downlink during T6 shall be BLER = 0.01±30%. (The final BLER shall be achieved by integrating over a number of repetitions of procedure step 10).

NOTE: If the above Test Requirement differs from the Minimum Requirement then the Test Tolerance applied for this test is non-zero. The Test Tolerance for this test is defined in clause F.2 and the explanation of how the Minimum Requirement has been relaxed by the Test Tolerance is given in clause F.4.

8.3.2 FDD/FDD Hard Handover

8.3.2.1 FDD/FDD Hard Handover to intra-frequency cell

8.3.2.1.1 Definition and applicability

The hard handover delay of the UE is defined as the time from the end of the last TTI containing an RRC message implying hard handover to the transmission of the new uplink DPCH.

The requirements and this test apply to the FDD UE.

8.3.2.1.2 Minimum requirement

The interruption time shall be less than 110 ms in CELL_DCH state in the single carrier case. The rate of correct handovers observed during repeated tests shall be at least 90% with a confidence level of 95 %.

The hard handover delay $D_{handover}$ equals the RRC procedure delay defined in TS 25.331 clause 13.5.2 plus the interruption time stated in TS 25.133 [2] clause 5.2.2.2 as follows:

The interruption time, i.e. the time between the last TTI containing a transport block on the old DPCH and the time the UE starts transmission of the new uplink DPCH, is depending on whether the target cell is known for the UE or not.

If intra-frequency hard handover is commanded or inter-frequency hard handover is commanded when the UE does not need compressed mode to perform inter-frequency measurements, the interruption time shall be less than $T_{interrupt1}$

For Release 99, Release 4 and Release 5 $T_{interrupt1}$ is the following equation:

$$T_{interrupt1} = T_{IU} + 40 + 20 * KC + 150 * OC + 10 * F_{max} \text{ ms}$$

where:

T_{IU} is the interruption uncertainty when changing the timing from the old to the new cell. T_{IU} can be up to one frame (10 ms).

KC is the number of known target cells in the message, and

OC is the number of target cells that are not known in the message.

F_{max} denotes the maximum number of radio frames within the transmission time intervals of all transport channels that are multiplexed into the same CCTrCH.

NOTE: The figure 40 ms is the time required for measuring the downlink DPCCH channel as stated in TS 25.214 clause 4.3.1.2.

For Release 6 and later releases $T_{interrupt1}$ is the following equation:

$$T_{interrupt1} = T_{IU} + T_{sync} + 20 * KC + 150 * OC + 10 * F_{max} \text{ ms}$$

where

T_{IU} is the interruption uncertainty when changing the timing from the old to the new cell. T_{IU} can be up to one frame (10 ms).

KC is the number of known target cells in the message, and

OC is the number of target cells that are not known in the message.

F_{max} denotes the maximum number of radio frames within the transmission time intervals of all transport channels that are multiplexed into the same CCTrCH.

T_{sync} is the time required for measuring the downlink DPCCH channel as stated in TS 25.214 section 4.3.1.2. In case higher layers indicate the usage of a post-verification period $T_{sync}=0$ ms. Otherwise $T_{sync}=40$ ms.

In the interruption requirement $T_{interrupt1}$ a cell is known if it has been measured by the UE during the last 5 seconds and the SFN of the cell has been decoded by the UE.

The normative reference for this requirement is TS 25.133 [2] clauses 5.2.2 and A.5.2.1.

8.3.2.1.3 Test purpose

To verify that the UE meets the minimum requirement.

8.3.2.1.4 Method of test

8.3.2.1.4.1 Initial conditions

Test environment: normal; see clauses G.2.1 and G.2.2.

Frequencies to be tested: mid range; see clause G.2.4.

The test parameters are given in tables 8.3.2.1.1 to 8.3.2.1.3 below. In the measurement control information it is indicated to the UE that event-triggered reporting with Event 1A and 1B shall be used, and that CPICH Ec/Io and SFN-CFN observed timed difference shall be reported together with Event 1A. The test consists of three successive time periods, with a time duration of T1, T2 and T3 respectively. At the start of time duration T1, the UE may not have any timing information of cell 2.

UTRAN shall send a PHYSICAL CHANNEL RECONFIGURATION with activation time "now" with one active cell, cell 2. The Physical Channel reconfiguration message shall be sent to the UE during period T2, after the UE has reported event 1A. The start of T3 is defined as the end of the last TTI containing the Physical Channel reconfiguration message.

N312 shall have the smallest possible value i.e. only one insync is required.

Table 8.3.2.1.1: General test parameters for Handover to intra-frequency cell

Parameter		Unit	Value	Comment
DCH parameters			DL and UL Reference Measurement Channel 12.2 kbps	As specified in clause C.3.1 and C.2.1
Power Control			On	
Target quality value on DTCH		BLER	0.001	
Initial conditions	Active cell		Cell 1	
	Neighbouring cell		Cell 2	
Final condition	Active cell		Cell 2	
Reporting range		dB	3	Applicable for event 1A and 1B
Hysteresis		dB	0	
W			1	Applicable for event 1A and 1B
Reporting deactivation threshold			0	Applicable for event 1A
Time to Trigger		ms	0	
Filter coefficient			0	
T1		s	5	
T2		s	≤5	
T3		s	5	

Table 8.3.2.1.2: Cell specific test parameters for Handover to intra-frequency cell

Parameter	Unit	Cell 1			Cell 2		
		T1	T2	T3	T1	T2	T3
CPICH_Ec/lor	dB	-10			-10		
PCCPCH_Ec/lor	dB	-12			-12		
SCH_Ec/lor	dB	-12			-12		
PICH_Ec/lor	dB	-15			-15		
DPCH_Ec/lor	dB	Note1	Note1	Note3	N/A	N/A	Note1
OCNS_Ec/lor	dB	Note2	Note2	Note2	-0.941	-0.941	Note2
\hat{I}_{or} / I_{oc}	dB	0	6.97		-Infinity	5.97	
$\hat{I}_{or} (Note 4)$	dBm	-70.00	-63.03		-Infinity	-64.03	
I_{oc}	dBm/3.84 MHz	-70					
CPICH_Ec/lo	dB	-13			-Infinity	-14	
Propagation Condition		AWGN					
NOTE 1: The DPCH level is controlled by the power control loop							
NOTE 2: The power of the OCNS channel that is added shall make the total power from the cell to be equal to I_{or} .							
NOTE 3: The DPCH may not be power controlled by the power control loop.							
NOTE 4: The nominal \hat{I}_{or} values, although not explicitly defined in 25.133 [2] are added here since they are implied and need to be identified so that the test equipment can be configured.							

8.3.2.1.4.2 Procedure

- 1) The RF parameters are set up according to T1 in table 8.3.2.1.3.
- 2) The UE is switched on.
- 3) A call is set up according to the test procedure specified in TS 34.108 [3] subclause 7.3.4. Data shall be sent on the DTCH throughout the call.
- 4) SS shall transmit a MEASUREMENT CONTROL message on cell 1.
- 5) 5 seconds after step 4 has completed, the SS shall switch the power settings from T1 to T2 in table 8.3.2.1.3.
- 6) UE shall transmit a MEASUREMENT REPORT message triggered by event 1A
- 7) SS shall transmit a PHYSICAL CHANNEL RECONFIGURATION message with activation time set to "now". The start of T3 is defined as the end of the last TTI containing the physical channel reconfiguration message.

- 8) The SS shall switch the power settings from T2 to T3 in table 8.3.2.1.3.
- 9) If the UE transmits the UL DPCCH to cell 2 less than 190 ms from the beginning of time period T3 then the number of successful tests is increased by one. The UE shall transmit a PHYSICAL CHANNEL RECONFIGURATION COMPLETE message on the UL DCCH of cell 2.
- 10) After 5 seconds from the beginning of time period T3, the UE is switched off. Any timing information of cell 2 is deleted in the UE.
- 11) Repeat step 1-10 until the confidence level according to annex F.6.2 is achieved

Specific Message Contents

All messages indicated above shall use the same content as described in the default message content in clause 9 of 34.108 [3], with the following exceptions:

MEASUREMENT CONTROL message (step 4):

Information Element/Group name	Value/Remark
Message Type (10.2.17)	
UE information elements -RRC transaction identifier -Integrity check info -message authentication code -RRC message sequence number	0 SS calculates the value of MAC-I for this message and writes to this IE. The first/ leftmost bit of the bit string contains the most significant bit of the MAC-I. SS provides the value of this IE, from its internal counter.
Measurement Information elements -Measurement Identity -Measurement Command (10.3.7.46) -Measurement Reporting Mode (10.3.7.49) -Measurement Report Transfer Mode -Periodical Reporting / Event Trigger Reporting Mode -Additional measurements list (10.3.7.1)	1 Modify AM RLC Event trigger Not Present
-CHOICE <i>Measurement type</i> -Intra-frequency measurement (10.3.7.36) -Intra-frequency measurement objects list (10.3.7.33) -Intra-frequency measurement quantity (10.3.7.38) -Filter coefficient (10.3.7.9) -CHOICE mode -Measurement quantity -Intra-frequency reporting quantity (10.3.7.41)	Intra-frequency measurement Not Present 0 FDD CPICH_Ec/N0
-Reporting quantities for active set cells (10.3.7.5) -Cell synchronisation information reporting indicator -Cell Identity reporting indicator -CHOICE mode -CPICH Ec/N0 reporting indicator -CPICH RSCP reporting indicator -Pathloss reporting indicator	TRUE (Note 1) TRUE FDD TRUE TRUE FALSE
-Reporting quantities for monitored set cells (10.3.7.5) -Cell synchronisation information reporting indicator -Cell Identity reporting indicator -CHOICE mode -CPICH Ec/N0 reporting indicator -CPICH RSCP reporting indicator -Pathloss reporting indicator	TRUE (Note 1) TRUE FDD TRUE TRUE FALSE
-Reporting quantities for detected set cells (10.3.7.5)	Not Present
-Reporting cell status (10.3.7.61) -Measurement validity (10.3.7.51) -CHOICE report criteria -Intra-frequency measurement reporting criteria (10.3.7.39) -Parameters required for each event	Not Present Not Present Intra-frequency measurement reporting criteria 2
-Intra-frequency event identity -Triggering condition 2 -Reporting Range Constant -Cells forbidden to affect Reporting Range -W -Hysteresis -Threshold used frequency -Reporting deactivation threshold -Replacement activation threshold -Time to trigger -Amount of reporting -Reporting interval -Reporting cell status (10.3.7.61) -CHOICE reported cell -Maximum number of reported cells -Intra-frequency event identity -Triggering condition 1 -Reporting Range Constant	Event 1A Monitored set cells 3 dB Not Present 1.0 0 dB Not Present 0 Not Present 0 ms Infinity 0 ms (Note 2) Report cells within active set and/or monitored set cells on used frequency 2 Event 1B Active set cells 3 dB

Information Element/Group name	Value/Remark
-Cells forbidden to affect Reporting Range -W -Hysteresis -Threshold used frequency -Reporting deactivation threshold -Replacement activation threshold -Time to trigger -Amount of reporting -Reporting interval -Reporting cell status (10.3.7.61) -CHOICE reported cell -Maximum number of reported cells	Not Present 1.0 0 dB Not Present Not Present Not Present 0 ms Not Present Not Present Report cells within active set and/or monitored set cells on used frequency 2
Physical channel information elements -DPCH compressed mode status info (10.3.6.34)	Not Present
<p>NOTE 1: The SFN-CFN observed time difference is calculated from the OFF and Tm parameters contained in the IE "Cell synchronisation information", TS 25.331, clause 10.3.7.6. According to TS 25.331, 8.6.7.7, this IE is included in MEASUREMENT REPORT if IE "Cell synchronisation information reporting indicator" in IE "Cell reporting quantities" TS 25.331, clause 10.3.7.5 is set to TRUE in MEASUREMENT CONTROL.</p> <p>NOTE 2: Reporting interval = 0 ms means no periodical reporting.</p>	

PHYSICAL CHANNEL RECONFIGURATION message (step 7):

Information Element	Value/Remark	Version
Message Type		
UE Information Elements		
-RRC transaction identifier	0	
-Integrity check info		
-message authentication code	SS calculates the value of MAC-I for this message and writes to this IE. The first/leftmost bit of the bit string contains the most significant bit of the MAC-I.	
-RRC message sequence number	SS provides the value of this IE, from its internal counter.	
-Integrity protection mode info	Not Present	
-Ciphering mode info	Not Present	
-Activation time	"now"	
-New U-RNTI	Not Present	
-New C-RNTI	Not Present	
-RRC State Indicator	CELL_DCH	
-UTRAN DRX cycle length coefficient	Not Present	
CN Information Elements		
-CN Information info	Not Present	
UTRAN mobility information elements		
-URA identity	Not Present	
RB information elements		
-Downlink counter synchronisation info	Not Present	
PhyCH information elements		
-Frequency info (10.3.6.36)		
-CHOICE mode	FDD	
-UARFCN uplink(Nu)	Same uplink UARFCN as used for cell 2	
-UARFCN downlink(Nd)	Same downlink UARFCN as used for cell 2	
Uplink radio resources		
-Maximum allowed UL TX power	33 dBm	
-CHOICE <i>channel requirement</i>	Uplink DPCH info	
-Uplink DPCH info (10.3.6.88)		
-Uplink DPCH power control info (10.3.6.91)		
-CHOICE mode	FDD	
-DPCCH power offset	-40 (-80dB)	
- PC Preamble	1 frame	
- SRB delay	7 frames	
- Power Control Algorithm	Algorithm1	
- TPC step size	1dB	
-CHOICE mode	FDD	
-Scrambling code type	Long	
-Scrambling code number	0 (0 to 16777215)	
-Number of DPDCH	Not Present(1)	
-Spreading factor	64	
-TFCl existence	TRUE	
-Number of FBI bit	Not Present(0)	
-Puncturing Limit	1	
Downlink radio resources		
-CHOICE <i>mode</i>	FDD	
-Downlink PDSCH information	Not Present	
-Downlink information common for all radio links (10.3.6.24)		
-Downlink DPCH info common for all RL (10.3.6.18)		
-Timing indicator	Initialise	
-CFN-targetSFN frame offset	Not Present	
-Downlink DPCH power control information (10.3.6.23)		
-DPC mode	0 (single)	
-CHOICE mode	FDD	
-Power offset $P_{Pilot-DPDCH}$	0	
-DL rate matching restriction information	Not Present	
-Spreading factor	128	
-Fixed or Flexible Position	Fixed	
-TFCl existence	TRUE	
-CHOICE SF	128	
		R99 and Rel-4 only

Information Element	Value/Remark	Version
-Number of bits for Pilot bits(SF=128,256)	8	
-CHOICE mode	FDD	
-DPCH compressed mode info (10.3.6.33)	Not Present	
-TX Diversity mode (10.3.6.86)	None	
-SSDT information (10.3.6.77)	Not Present	R99 and Rel-4 only
-Default DPCH Offset Value (10.3.6.16)	0	
-Downlink information per radio link list	1	
-Downlink information for each radio link (10.3.6.27)		
-CHOICE mode	FDD	
-Primary CPICH info (10.3.6.60)		
-Primary scrambling code	150	
-PDSCH with SHO DCH info (10.3.6.47)	Not Present	R99 and Rel-4 only
-PDSCH code mapping (10.3.6.43)	Not Present	R99 and Rel-4 only
-Downlink DPCH info for each RL (10.3.6.21)		
-CHOICE mode	FDD	
-Primary CPICH usage for channel estimation	Primary CPICH may be used	
-DPCH frame offset	0 chips	
-Secondary CPICH info	Not Present	
-DL channelisation code		
-Secondary scrambling code	Not Present	
-Spreading factor	128	
-Code number	96	
-Scrambling code change	No change	
-TPC combination index	0	
- SSDT Cell Identity	Not Present	R99 and Rel-4 only
- Closed loop timing adjustment mode	Not Present	
- SCCPCH information for FACH (10.3.6.70)	Not Present	

MEASUREMENT REPORT message for Intra frequency test cases

Information Element	Value/remark
Message Type	
Integrity check info	The presence of this IE is dependent on IXIT statements in TS 34.123-2. If integrity protection is indicated to be active, this IE shall be present with the values of the sub IEs as stated below. Else, this IE and the sub-IEs shall be absent.
- Message authentication code	This IE is checked to see if it is present. The value is compared against the XMAC-I value computed by SS.
- RRC Message sequence number	This IE is checked to see if it is present. The value is used by SS to compute the XMAC-I value.
Measurement identity	1
Measured Results	
- Intra-frequency measured results list	
- Cell measured results	
- Cell Identity	Not present
- SFN-SFN observed time difference	Checked that this IE is present
- Cell synchronisation information	
- Tm	Checked that this IE is present
- OFF	Checked that this IE is present
- CHOICE mode	FDD
- Primary CPICH info	Checked that this IE is present
- Primary scrambling code	100
- CPICH Ec/N0	Checked that this IE is present
- CPICH RSCP	Checked that this IE is present
- Cell measured results	
- Cell Identity	Not present
- Cell synchronisation information	
- Tm	Checked that this IE is present
- OFF	Checked that this IE is present
- CHOICE mode	FDD
- Primary CPICH info	Checked that this IE is present
- Primary scrambling code	150
- CPICH Ec/N0	Checked that this IE is present
- CPICH RSCP	Checked that this IE is present
- Pathloss	Checked that this IE is absent
Measured results on RACH	Checked that this IE is absent
Additional measured results	Checked that this IE is absent
Event results	Checked that this IE is present

8.3.2.1.5 Test requirements

For the test to pass, the total number of successful tests shall be more than 90 % of the cases with a confidence level of 95 %.

Table 8.3.2.1.3: Test requirements for Handover to intra-frequency cell

Parameter	Unit	Cell 1			Cell 2		
		T1	T2	T3	T1	T2	T3
CPICH_Ec/Ior	dB	-9.3			-9.3		
PCCPCH_Ec/Ior	dB	-11.3			-11.3		
SCH_Ec/Ior	dB	-11.3			-11.3		
PICH_Ec/Ior	dB	-14.3			-14.3		
DPCH_Ec/Ior	dB	Note1	Note1	Note3	N/A	N/A	Note1
OCNS_Ec/Ior	dB	Note2	Note2	Note2	-1.13	-1.13	Note2
\hat{I}_{or}/I_{oc} (Note 4)	dB	0	7.0		-Infinity	6.0	
\hat{I}_{or}	dBm	-70.0	-63.0		-Infinity	-64.0	
I_{oc}	dBm/3. 84 MHz	-70					
CPICH_Ec/Io (Note 4)	dB	-12.3			-Infinity	-13.3	
Propagation Condition		AWGN					
NOTE 1: The DPCH level is controlled by the power control loop							
NOTE 2: The power of the OCNS channel that is added shall make the total power from the cell to be equal to I_{or} .							
NOTE 3: The DPCH may not be power controlled by the power control loop.							
NOTE 4: These parameters are not directly settable, but are derived by calculation from the settable parameters.							

NOTE: If the above Test Requirement differs from the Minimum Requirement then the Test Tolerance applied for this test is non-zero. The Test Tolerance for this test is defined in clause F.2 and the explanation of how the Minimum Requirement has been relaxed by the Test Tolerance is given in clause F.4.

8.3.2.2 FDD/FDD Hard Handover to inter-frequency cell

8.3.2.2.1 Definition and applicability

The hard handover delay is defined as the time from the end of the last TTI containing an RRC message implying hard handover to the transmission of the new uplink DPCH.

The requirements and this test apply to the FDD UE.

8.3.2.2.2 Minimum requirement

The interruption time shall be less than 140 ms in CELL_DCH state in the dual carrier case. The rate of correct handovers observed during repeated tests shall be at least 90% with a confidence level of 95 %.

The hard handover delay $D_{handover}$ equals the RRC procedure delay defined in TS 25.331 clause 13.5.2 plus the interruption time stated in TS 25.133 [2] clause 5.2.2.2 as follows:

If inter-frequency hard handover is commanded and the UE needs compressed mode to perform inter-frequency measurements, the interruption time shall be less than $T_{interrupt2}$

For Release 99, Release 4 and Release 5 $T_{interrupt1}$ is the following equation: $T_{interrupt2} = T_{IU} + 40 + 50 * KC + 150 * OC + 10 * F_{max}$ ms

For Release 6 and later releases $T_{interrupt1}$ is the following equation:

$$T_{interrupt2} = T_{IU} + T_{sync} + 50 * KC + 150 * OC + 10 * F_{max} \text{ ms}$$

In the interruption requirement $T_{interrupt2}$ a cell is known if:

- the cell has been measured by the UE during the last 5 seconds.

The phase reference is the primary CPICH.

The normative reference for this requirement is TS 25.133 [2] clauses 5.2.2 and A.5.2.2.

8.3.2.2.3 Test purpose

To verify that the UE meets the minimum requirement.

8.3.2.2.4 Method of test

8.3.2.2.4.1 Initial conditions

Test environment: normal; see clauses G.2.1 and G.2.2.

Frequencies to be tested: mid range; see clause G.2.4.

The test parameters are given in tables 8.3.2.2.1 to 8.3.2.2.3 below. The test consists of three successive time periods, with a time duration of T1, T2 and T3 respectively. In the measurement control information it is indicated to the UE that event-triggered reporting with Event 2C shall be used. The CPICH E_c/I_0 of the best cell on the unused frequency shall be reported together with Event 2C reporting. At the start of time duration T1, the UE may not have any timing information of cell 2.

UTRAN shall send a PHYSICAL CHANNEL RECONFIGURATION with activation time "now" with one active cell, cell 2. The Physical Channel reconfiguration message shall be sent to the UE during period T2, after the UE has reported event 2C. The start of T3 is defined as the end of the last TTI containing the Physical Channel reconfiguration message.

N312 shall have the smallest possible value i.e. only one insync is required.

Table 8.3.2.2.1: General test parameters for Handover to inter-frequency cell

Parameter		Unit	Value	Comment
DCH parameters			DL and UL Reference Measurement Channel 12.2 kbps	As specified in clause C.3.1 and C.2.1
Power Control			On	
Target quality value on DTCH		BLER	0.001	
Compressed mode			A.22 set 1	As specified in TS 34.121 clause C.5.
Initial conditions	Active cell		Cell 1	
	Neighbour cell		Cell 2	
Final conditions	Active cell		Cell 2	
Threshold non used frequency		dB	-18	Absolute E_c/I_0 threshold for event 2C
Hysteresis		dB	0	
W non-used frequency			1	Applicable for event 2C
Time to Trigger		ms	0	
Filter coefficient			0	
T1		s	5	
T2		s	≤5	
T3		s	5	

Table 8.3.2.2.2: Cell Specific parameters for Handover to inter-frequency cell

Parameter	Unit	Cell 1			Cell 2		
		T1	T2	T3	T1	T2	T3
UTRA RF Channel Number		Channel 1			Channel 2		
CPICH_Ec/I _{or}	dB	-10			-10		
PCCPCH_Ec/I _{or}	dB	-12			-12		
SCH_Ec/I _{or}	dB	-12			-12		
PICH_Ec/I _{or}	dB	-15			-15		
DPCH_Ec/I _{or}	dB	Note1	Note1	Note3	N/A	N/A	Note1
OCNS_Ec/I _{or}	dB	Note2	Note2	Note2	-0.941	-0.941	Note2
\hat{I}_{or}/I_{oc}	dB	0			-Infinity	-1.8	-1.8
\hat{I}_{or} (Note 4)	dBm	-70.0			-Infinity	-71.8	-71.8
I_{oc}	dBm/3. 84 MHz	-70					
CPICH_Ec/I _o	dB	-13			-Infinity	-14	
Propagation Condition		AWGN					
NOTE 1: The DPCH level is controlled by the power control loop							
NOTE 2: The power of the OCNS channel that is added shall make the total power from the cell to be equal to I_{or} .							
NOTE 3: The DPCH may not be power controlled by the power control loop.							
NOTE 4: The nominal \hat{I}_{or} values, although not explicitly defined in 25.133 [2] are added here since they are implied and need to be identified so that the test equipment can be configured.							

8.3.2.2.4.2 Procedure

- 1) The RF parameters are set up according to T1 in table 8.3.2.2.3.
- 2) The UE is switched on.
- 3) A call is set up according to the test procedure specified in TS 34.108 [3] subclause 7.3.4 with Compressed mode parameters as in Table 8.3.2.2.1. Data shall be sent on the DTCH throughout the call.
- 4) SS shall transmit a MEASUREMENT CONTROL message on cell 1.
- 5) 5 seconds after step 4 has completed, the SS shall switch the power settings from T1 to T2 in table 8.3.2.2.3.
- 6) UE shall transmit a MEASUREMENT REPORT message triggered by event 2C
- 7) SS shall transmit a PHYSICAL CHANNEL RECONFIGURATION message with activation time "now". The start of T3 is defined as the end of the last TTI containing the physical channel reconfiguration message.
- 8) The SS shall switch the power settings from T2 to T3 in table 8.3.2.2.3.
- 9) If the UE transmits the UL DPCCH to cell 2 less than 220 ms from the beginning of time period T3 then the number of successful tests is increased by one. The UE shall transmit a PHYSICAL CHANNEL RECONFIGURATION COMPLETE message on the UL DCCH of cell 2.
- 10) After 5 seconds from the beginning of time period T3, the UE is switched off. Any timing information of cell 2 is deleted in the UE.
- 11) Repeat step 1-10 until the confidence level according to annex F.6.2 is achieved

Specific Message Contents

All messages indicated below shall use the same content as described in the default message content in clause 9 of 34.108 [3], with the following exceptions:

MEASUREMENT CONTROL message, event 2C (step 4):

Information Element/Group name	Value/Remark
Message Type (10.2.17)	
UE information elements -RRC transaction identifier -Integrity check info -message authentication code -RRC message sequence number	0 SS calculates the value of MAC-I for this message and writes to this IE. The first/ leftmost bit of the bit string contains the most significant bit of the MAC-I. SS provides the value of this IE, from its internal counter.
Measurement Information elements -Measurement Identity -Measurement Command (10.3.7.46) -Measurement Reporting Mode (10.3.7.49) -Measurement Report Transfer Mode -Periodical Reporting / Event Trigger Reporting Mode -Additional measurements list (10.3.7.1)	2 Setup AM RLC Event trigger Not Present
-CHOICE <i>Measurement type</i> -Inter-frequency measurement (10.3.7.16) -Inter-frequency measurement objects list (10.3.7.13) - CHOICE Inter-frequency cell removal - New Inter frequency cells - Inter frequency cell id - Frequency info - CHOICE mode - UARFCN uplink(Nu) - UARFCN downlink(Nd) - Cell info - Cell individual offset - Reference time difference to cell - Read SFN indicator - CHOICE mode - Primary CPICH info - Primary scrambling code - Primary CPICH Tx Power - Tx Diversity Indicator - Cell for measurement -Inter-frequency measurement quantity (10.3.7.18) -CHOICE reporting criteria -Inter-frequency reporting criteria -Filter coefficient -CHOICE mode -Measurement quantity for frequency quality estimate	Inter-frequency measurement Not Present 4 FDD Not Present Same frequency as "Channel2" in Table 8.3.2.2.2 Not Present Not Present FALSE FDD Set to Primary scrambling code of Cell2 Set to Primary CPICH Tx Power of Cell2 described in Table 8.3.2.2.2 FALSE Not Present Inter-frequency reporting criteria 0 FDD CPICH Ec/N0
-Inter-frequency reporting quantity (10.3.7.21) -UTRA Carrier RSSI -Frequency quality estimate -Non frequency related cell reporting quantities (10.3.7.5) -Cell synchronisation information reporting indicator -Cell Identity reporting indicator -CHOICE mode -CPICH Ec/N0 reporting indicator -CPICH RSCP reporting indicator -Pathloss reporting indicator	FALSE FALSE TRUE TRUE FDD TRUE TRUE FALSE
-Reporting cell status (10.3.7.61) -Measurement validity (10.3.7.51) -Inter-frequency set update (10.3.7.22) -UE autonomous update mode	Not Present Not Present On with no reporting
-CHOICE report criteria	Inter-frequency measurement reporting criteria
-Inter-frequency measurement reporting criteria (10.3.7.19) -Parameters required for each event -Inter-frequency event identity (10.3.7.14) -Threshold used frequency	1 Event 2C Not Present

Information Element/Group name	Value/Remark
-W used frequency -Hysteresis -Time to trigger -Reporting cell status (10.3.7.61) -CHOICE reported cell -Maximum number of reported cells per reported non-used frequency -Parameters required for each non-used frequency -Threshold non-used frequency -W non-used frequency	Not Present 0 dB 0 ms Report cells within monitored and/or virtual active set on non-used frequency 1 1 -18 dB 1
Physical channel information elements -DPCH compressed mode status info (10.3.6.34)	Not Present

PHYSICAL CHANNEL RECONFIGURATION message (step 7):

Information Element	Value/Remark	Version
Message Type		
UE Information Elements		
-RRC transaction identifier	0	
-Integrity check info		
-message authentication code	SS calculates the value of MAC-I for this message and writes to this IE. The first/leftmost bit of the bit string contains the most significant bit of the MAC-I.	
-RRC message sequence number	SS provides the value of this IE, from its internal counter.	
-Integrity protection mode info	Not Present	
-Ciphering mode info	Not Present	
-Activation time	"now"	
-New U-RNTI	Not Present	
-New C-RNTI	Not Present	
-RRC State Indicator	CELL_DCH	
-UTRAN DRX cycle length coefficient	Not Present	
CN Information Elements		
-CN Information info	Not Present	
UTRAN mobility information elements		
-URA identity	Not Present	
RB information elements		
-Downlink counter synchronisation info	Not Present	
>RB with PDCP information list	Not Present	
>>RB with PDCP information	Not Present	
PhyCH information elements		
-Frequency info (10.3.6.36)		
-CHOICE mode	FDD	
-UARFCN uplink(Nu)	Same uplink UARFCN as used for cell 2	
-UARFCN downlink(Nd)	Same downlink UARFCN as used for cell 2	
Uplink radio resources		
-Maximum allowed UL TX power	33 dBm	
-CHOICE <i>channel requirement</i>	Uplink DPCH info	
-Uplink DPCH info (10.3.6.88)		
-Uplink DPCH power control info (10.3.6.91)		
-CHOICE mode	FDD	
-DPCCH power offset	-40 (-80dB)	
- PC Preamble	1 frame	
- SRB delay	7 frames	
- Power Control Algorithm	Algorithm1	
- TPC step size	1dB	
-CHOICE mode	FDD	
-Scrambling code type	Long	
-Scrambling code number	0 (0 to 16777215)	
-Number of DPDCH	Not Present(1)	
-Spreading factor	64	
-TFCH existence	TRUE	
-Number of FBI bit	Not Present(0)	
-Puncturing Limit	1	
Downlink radio resources		
-CHOICE <i>mode</i>	FDD	
-Downlink PDSCH information	Not Present	
-Downlink information common for all radio links (10.3.6.24)		
-Downlink DPCH info common for all RL (10.3.6.18)		
-Timing indicator	Initialise	
-CFN-targetSFN frame offset	Not Present	
-Downlink DPCH power control information (10.3.6.23)		
-DPC mode	0 (single)	
-CHOICE mode	FDD	
-Power offset $P_{Pilot-DPDCH}$	0	
-DL rate matching restriction information	Not Present	
-Spreading factor	128	
-Fixed or Flexible Position	Fixed	
		R99 and Rel-4 only

Information Element	Value/Remark	Version
-TFCI existence	TRUE	
-CHOICE SF	128	
-Number of bits for Pilot bits(SF=128,256)	8	
-CHOICE mode	FDD	
-DPCH compressed mode info (10.3.6.33)		
- Transmission gap pattern sequence	1	
- TGPSI	1	
- TGPS Status Flag	deactivate	
- TGCFN	Not Present	
- Transmission gap pattern sequence	Not Present	
configuration parameters		
-TX Diversity mode (10.3.6.86)	None	
-SSDT information (10.3.6.77)	Not Present	R99 and Rel-4 only
-Default DPCH Offset Value (10.3.6.16)	0	
-Downlink information per radio link list	1	
-Downlink information for each radio link (10.3.6.27)		
-CHOICE mode	FDD	
-Primary CPICH info (10.3.6.60)		
-Primary scrambling code	250	
-PDSCH with SHO DCH info (10.3.6.47)	Not Present	R99 and Rel-4 only
-PDSCH code mapping (10.3.6.43)	Not Present	R99 and Rel-4 only
-Downlink DPCH info for each RL (10.3.6.21)		
-CHOICE mode	FDD	
-Primary CPICH usage for channel estimation	Primary CPICH may be used	
-DPCH frame offset	0 chips	
-Secondary CPICH info	Not Present	
-DL channelisation code		
-Secondary scrambling code	Not Present	
-Spreading factor	128	
-Code number	96	
-Scrambling code change	No change	
-TPC combination index	0	
- SSDT Cell Identity	Not Present	R99 and Rel-4 only
- Closed loop timing adjustment mode	Not Present	
- SCCPCH information for FACH (10.3.6.70)	Not Present	

MEASUREMENT REPORT message for Inter frequency test cases

Information Element	Value/remark
Message Type	The presence of this IE is dependent on IXIT statements in TS 34.123-2. If integrity protection is indicated to be active, this IE shall be present with the values of the sub IEs as stated below. Else, this IE and the sub-IEs shall be absent.
Integrity check info	
- Message authentication code	This IE is checked to see if it is present. The value is compared against the XMAC-I value computed by SS.
- RRC Message sequence number	This IE is checked to see if it is present. The value is used by SS to compute the XMAC-I value.
Measurement identity	2
Measured Results	Checked that this IE is present Not present Checked that this IE is present FDD Checked that this IE is present 250 Checked that this IE is present Checked that this IE is present Checked that this IE is absent Checked that this IE is absent Checked that this IE is absent Checked that this IE is present
- Inter-frequency measured results	
- Frequency Info	
- Inter-freqcell measured results list	
- Cell measured results	
- Cell Identity	
- Cell synchronisation information	
- Tm	
- CHOICE mode	
- Primary CPICH info	
- Primary scrambling code	
- CPICH Ec/N0	
- CPICH RSCP	
- Pathloss	
Measured results on RACH	Checked that this IE is absent
Additional measured results	Checked that this IE is absent
Event results	Checked that this IE is present

8.3.2.2.5 Test requirements

For the test to pass, the total number of successful tests shall be more than 90% of the cases with a confidence level of 95 %.

Table 8.3.2.2.3: Test requirements for Handover to inter-frequency cell

Parameter	Unit	Cell 1			Cell 2		
		T1	T2	T3	T1	T2	T3
UTRA RF Channel Number		Channel 1			Channel 2		
CPICH_Ec/Ior	dB	-9.2			-9.2		
PCCPCH_Ec/Ior	dB	-11.2			-11.2		
SCH_Ec/Ior	dB	-11.2			-11.2		
PICH_Ec/Ior	dB	-14.2			-14.2		
DPCH_Ec/Ior	dB	Note1	Note1	Note3	N/A	N/A	Note1
OCNS_Ec/Ior	dB	Note2	Note2	Note2	-1.16	-1.16	Note2
\hat{I}_{or} / I_{oc} (Note 4)	dB	0			-Infinity	-1.8	-1.8
\hat{I}_{or}	dBm	-70.0			-Infinity	-71.8	-71.8
I_{oc}	dBm/3.84 MHz	-70					
CPICH_Ec/Io (Note 4)	dB	-12.2			-Infinity	-13.2	
Propagation Condition		AWGN					
NOTE 1: The DPCH level is controlled by the power control loop							
NOTE 2: The power of the OCNS channel that is added shall make the total power from the cell to be equal to I_{or} .							
NOTE 3: The DPCH may not be power controlled by the power control loop.							
NOTE 4: These parameters are not directly settable, but are derived by calculation from the settable parameters.							

NOTE: If the above Test Requirement differs from the Minimum Requirement then the Test Tolerance applied for this test is non-zero. The Test Tolerance for this test is defined in clause F.2 and the explanation of how the Minimum Requirement has been relaxed by the Test Tolerance is given in clause F.4.

8.3.3 FDD/TDD Handover

8.3.3.1 Definition and applicability

The hard handover delay is defined as the time from the end of the last TTI containing an RRC message implying hard handover to the transmission of the new uplink DPCCH.

The requirements and this test apply to the combined FDD and TDD UE for Release 99 and Release 4 only.

8.3.3.2 Minimum requirement

The hard handover delay shall be less than 110 ms in CELL_DCH state in the dual carrier case. The rate of correct handovers observed during repeated tests shall be at least 90% with a confidence level of 95 %.

The hard handover delay D_{handover} equals the RRC procedure delay defined in TS 25.331 clause 13.5.2 plus the interruption time stated in TS 25.133 [2] clause 5.3.2.2 as follows:

If FDD/TDD handover is commanded, the interruption time shall be less than:

$$T_{\text{interrupt}} = T_{\text{offset}} + T_{\text{UL}} + 30 * F_{\text{SFN}} + 20 * \text{KC} + 180 * \text{UC} + 10 * F_{\text{max}} \text{ ms}$$

where,

T_{offset}	Equal to 10 ms, the frame timing uncertainty between the old cell and the target cell and the time that can elapse until the appearance of a Beacon channel
T_{UL}	Equal to 10 ms, the time that can elapse until the appearance of the UL timeslot in the target cell
F_{SFN}	Equal to 1 if SFN decoding is required and equal to 0 otherwise
KC	Equal to 1 if a known target cell is indicated in the RRC message implying FDD/TDD handover and equal to 0 otherwise
UC	Equal to 1 if an unknown target cell is indicated in the RRC message implying FDD/TDD handover and equal to 0 otherwise
F_{max}	Denotes the maximum number of radio frames within the transmission time intervals of all transport channels that are multiplexed into the same CCTrCH.

An inter-frequency TDD target cell shall be considered known by the UE, if the target cell has been measured by the UE during the last 5 seconds.

The phase reference is the primary CPICH.

The normative reference for this requirement is TS 25.133 [2] clauses 5.3.2 and A.5.3.2.

8.3.3.3 Test purpose

To verify that the UE meets the minimum requirement.

8.3.3.4 Method of test

8.3.3.4.1 Initial conditions

Test environment: normal; see clauses G.2.1 and G.2.2.

Frequencies to be tested: mid range; see clause G.2.4.

The test parameters are given in Table 8.3.2.2.1 and 8.3.2.2.2 below. The test consists of three successive time periods, with a time duration of T1, T2 and T3 respectively. In the measurement control information it is indicated to the UE that event-triggered reporting with Event 2C shall be used. The Primary CCPCH RSCP of the best cell on the unused frequency shall be reported together with Event 2C reporting. At the start of time duration T1, the UE may not have any timing information of cell 2.

UTRAN shall send a PHYSICAL CHANNEL RECONFIGURATION with activation time "now" with one active cell, cell 2. The Physical Channel reconfiguration message shall be sent to the UE so that the whole message is available at the UE the RRC procedure delay prior to the beginning of T3. The RRC procedure delay is defined in TS 25.133 [2].

The UL DPCH in cell 2 shall be transmitted in timeslot 10.

Table 8.3.3.1: General test parameters for Handover to TDD cell

Parameter	Unit	Value	Comment
DCH parameters		DL and UL Reference Measurement Channel 12.2 kbps	As specified in TS 34.121 clause C.3.1 and in TS 34.122 clause C.2.2
Power Control		On	
Target quality value on DTCH	BLER	0.001	
Compressed mode		A.22 set 3	As specified in TS 34.121 clause C.5
Initial conditions	Active cell	Cell 1	FDD cell
	Neighbour cell	Cell 2	TDD cell
Final condition	Active cell	Cell 2	TDD cell
O	dB	0	Cell individual offset. This value shall be used for all cells in the test.
Hysteresis	dB	0	Hysteresis parameter for event 2C
Time to Trigger	ms	0	
Threshold non-used frequency	dBm	-75	Applicable for Event 2C
Filter coefficient		0	
Monitored cell list size		6 FDD neighbours on Channel 1 6 TDD neighbours on Channel 2	
T _{SI}	s	1.28	The value shall be used for all cells in the test
T1	s	5	
T2	s	15	
T3	s	5	

Table 8.3.3.2: Cell Specific parameters for Handover to TDD cell (cell 1)

Parameter	Unit	Cell 1	
		T1, T2	T3
UTRA RF Channel Number		Channel 1	
CPICH_Ec/I _{or}	dB	-10	
P-CCPCH_Ec/I _{or}	dB	-12	
SCH_Ec/I _{or}	dB	-12	
PICH_Ec/I _{or}	dB	-15	
DPCH_Ec/I _{or}	dB	Note 1	n.a.
OCNS_Ec/I _{or}	dB	Note 2	
\hat{I}_{or}/I_{oc}	dB	0	
I _{oc}	dBm/3.84 MHz	-70	
CPICH_Ec/I _o	dB	-13	
Propagation Condition		AWGN	
NOTE 1: The DPCH level is controlled by the power control loop			
NOTE 2: The power of the OCNS channel that is added shall make the total power from the cell to be equal to I _{or}			

Table 8.3.3.3: Cell Specific parameters for Handover to TDD cell (cell 2)

Parameter	Unit	Cell 2								
		0			2			8		
DL timeslot number		T1	T2	T3	T1	T2	T3	T1	T2	T3
UTRA RF Channel Number		Channel 2								
P-CCPCH_Ec/lor	dB	-3			n.a.			n.a.		
PICH_Ec/lor	dB	n.a.			n.a.			-3		
SCH_Ec/lor	dB	-9			n.a.			-9		
SCH_t_offset	dB	5			n.a.			5		
DPCH_Ec/lor	dB	n.a.			n.a.		Note 1	n.a.		
OCNS_Ec/lor	dB	-3.12			0		Note 2	-3.12		
\hat{I}_{or}/I_{oc}	dB	-Inf	6	-Inf	6			-Inf	6	
P-CCPCH RSCP	dBm	-Inf	-67	n.a.			n.a.			
I_{oc}	dBm/3, 84 MHz	-70								
Propagation Condition		AWGN								
NOTE 1: The DPCH level is controlled by the power control loop										
NOTE 2: The power of the OCNS channel that is added shall make the total power from the cell to be equal to lor.										
Note that the transmit energy per PN chip for the SCH is averaged over the 256 chip duration when the SCH is present in the time slot.										

8.3.3.4.2 Procedure

- 1) The RF parameters are set up according to T1.
- 2) The UE is switched on.
- 3) A call is set up according to the test procedure specified in TS 34.108 [3] subclause 7.3.4 with Compressed mode parameters as in Table 8.3.2.2.1. Data shall be sent on the DTCH throughout the call.
- 4) SS shall transmit a MEASUREMENT CONTROL message.
- 5) After 5 seconds, the SS shall switch the power settings from T1 to T2.
- 6) UE shall transmit a MEASUREMENT REPORT message triggered by event 2C.
- 7) SS shall transmit a PHYSICAL CHANNEL RECONFIGURATION message with activation time "now".
- 8) After 10 seconds, the SS shall switch the power settings from T2 to T3.
- 9) UE shall transmit a PHYSICAL CHANNEL RECONFIGURATION COMPLETE message on the UL DCCH of cell 2. If the UE transmits the UL DPCCH to cell 2 less than 110 ms from the beginning of time period T3 then the number of successful tests is increased by one.
- 10) After 5 seconds, the UE is switched off. Any timing information of cell 2 is deleted in the UE.
- 11) Repeat step 1-10 until the confidence level according to annex F.6.2 is achieved.

Specific Message Contents

All messages indicated above shall use the same content as described in the default message content in clause 9 of 34.108 [3], with the following exceptions:

MEASUREMENT CONTROL message, event 2C (step 4):

Information Element/Group name	Value/Remark
Message Type (10.2.17)	
UE information elements	
-RRC transaction identifier	0
-Integrity check info	
-message authentication code	SS calculates the value of MAC-I for this message and writes to this IE. The first/ leftmost bit of the bit string contains the most significant bit of the MAC-I.
-RRC message sequence number	SS provides the value of this IE, from its internal counter.
Measurement Information elements	
-Measurement Identity	1
-Measurement Command (10.3.7.46)	Modify
-Measurement Reporting Mode (10.3.7.49)	
-Measurement Report Transfer Mode	AM RLC
-Periodical Reporting / Event Trigger Reporting Mode	Event trigger
-Additional measurements list (10.3.7.1)	Not Present
-CHOICE <i>Measurement type</i>	Inter-frequency measurement
-Inter-frequency measurement (10.3.7.16)	
-Inter-frequency measurement objects list (10.3.7.13)	Not Present
-Inter-frequency measurement quantity (10.3.7.18)	
-CHOICE <i>reporting criteria</i>	Inter-frequency reporting criteria
-Inter-frequency reporting criteria	
-Filter coefficient	0
-CHOICE <i>mode</i>	TDD
-Measurement quantity for frequency quality estimate	Primary CCPCH RSCP
-Inter-frequency reporting quantity (10.3.7.21)	
-UTRA Carrier RSSI	FALSE
-Frequency quality estimate	FALSE
-Non frequency related cell reporting quantities (10.3.7.5)	
-Cell synchronisation information reporting indicator	TRUE
-Cell Identity reporting indicator	TRUE
-CHOICE <i>mode</i>	TDD
-Timeslot ISCP reporting indicator	TRUE
-Proposed TGSN reporting required	FALSE
-Primary CCPCH RSCP reporting indicator	TRUE
-Pathloss reporting indicator	TRUE
-Reporting cell status (10.3.7.61)	
-CHOICE <i>reported cell</i>	Report cells within monitored set on non-used frequency
-Maximum number of reported cells per reported non-used frequency	1
-Measurement validity (10.3.7.51)	Not Present
-Inter-frequency set update (10.3.7.22)	Not Present
-CHOICE <i>report criteria</i>	Inter-frequency measurement reporting criteria
-Inter-frequency measurement reporting criteria (10.3.7.19)	
-Parameters required for each event	1
-Inter-frequency event identity (10.3.7.14)	Event 2C
-Threshold used frequency	Not Present
-W used frequency	Not Present
-Hysteresis	0 dB
-Time to trigger	0 ms
-Reporting cell status (10.3.7.61)	
-CHOICE <i>reported cell</i>	Report cells within monitored set on non-used frequency
-Maximum number of reported cells per reported non-used frequency	1
-Parameters required for each non-used frequency	1
-Threshold non-used frequency	-80 dBm
-W non-used frequency	1
Physical channel information elements	
-DPCH compressed mode status info (10.3.6.34)	Not Present

PHYSICAL CHANNEL RECONFIGURATION message (step 7):

Information Element	Value/Remark
Message Type	
UE Information Elements	
-RRC transaction identifier	0
-Integrity check info	
-message authentication code	SS calculates the value of MAC-I for this message and writes to this IE. The first/ leftmost bit of the bit string contains the most significant bit of the MAC-I.
-RRC message sequence number	SS provides the value of this IE, from its internal counter.
-Integrity protection mode info	Not Present
-Ciphering mode info	Not Present
-Activation time	"now"
-New U-RNTI	Not Present
-New C-RNTI	Not Present
-RRC State Indicator	CELL_DCH
-UTRAN DRX cycle length coefficient	Not Present
CN Information Elements	
-CN Information info	Not Present
UTRAN mobility information elements	
-URA identity	Not Present
RB information elements	
-Downlink counter synchronisation info	Not Present
-RB with PDCP information list	Not Present
-RB with PDCP information	Not Present
PhyCH information elements	
-Frequency info (10.3.6.36)	
-CHOICE <i>mode</i>	TDD
-UARFCN (Nt)	Same UARFCN as used for cell 2
Uplink radio resources	
-Maximum allowed UL TX power	33 dBm
-CHOICE <i>channel requirement</i>	Uplink DPCH info
-Uplink DPCH info (10.3.6.88)	
-Uplink DPCH power control info (10.3.6.91)	
-CHOICE <i>mode</i>	TDD
-CHOICE <i>TDD option</i>	3.84 Mcps TDD
-UL Target SIR	Not Present
-CHOICE <i>UL OL PC info</i>	Individually signalled
-CHOICE <i>TDD option</i>	3.84 Mcps TDD
-Individual Timeslot interference info	1
-Individual timeslot interference (10.3.6.38)	
-Timeslot Number (10.3.6.84)	
-CHOICE <i>TDD option</i>	3.84 Mcps TDD
-Timeslot number	10
- UL Timeslot Interference	-90 dBm
-CHOICE <i>mode</i>	TDD
-Uplink timing advance control (10.3.6.96)	
-CHOICE <i>Timing Advance</i>	Disabled
-UL CCTrCH list	1
-UL Target SIR	TBD dB
-Time Info (10.3.6.83)	
-Activation Time	"now"
-Duration	Infinite
-Common timeslot info	Not Present
-Uplink DPCH timeslots and codes (10.3.6.94)	
-Dynamic SF Usage	False
-First individual timeslot info (10.3.6.37)	
-Timeslot Number (10.3.6.84)	
-CHOICE <i>TDD option</i>	3.84 Mcps
-Timeslot number	10
-TFCl existence	True
-Midamble shift and burst type (10.3.6.41)	
-CHOICE <i>TDD option</i>	3.84 Mcps
-CHOICE <i>Burst Type</i>	Type 1
-Midamble Allocation Mode	Default

Information Element	Value/Remark
-Midamble configuration burst type 1 and 3	16
-Midamble shift	Not present
-CHOICE <i>TDD option</i>	3.84 Mcps
-First timeslot code list	1
-Channelisation code	8/1
-CHOICE <i>more timeslots</i>	No more timeslots
Downlink radio resources	
-CHOICE <i>mode</i>	TDD
-Downlink information common for all radio links (10.3.6.24)	
-Downlink DPCH info common for all RL (10.3.6.18)	
-Timing indicator	Initialise
-CFN-targetSFN frame offset	Not Present
-Downlink DPCH power control information (10.3.6.23)	
-CHOICE <i>mode</i>	TDD
-TPC Step size	1 dB
-CHOICE <i>mode</i>	TDD
-CHOICE <i>mode</i>	TDD
-CHOICE <i>TDD option</i>	3.84 Mcps
-TX Diversity mode (10.3.6.86)	None
-Default DPCH Offset Value (10.3.6.16)	0
-Downlink information per radio link list	1
-Downlink information for each radio link (10.3.6.27)	
-CHOICE <i>mode</i>	TDD
-Primary CCPCH info (10.3.6.57)	
- CHOICE <i>mode</i>	TDD
- CHOICE <i>TDD option</i>	3.84 Mcps
- CHOICE <i>sync case</i>	Case 2
- Timeslot	0
- Cell parameters ID	20
- SCTD indicator	False
-Downlink DPCH info for each RL (10.3.6.21)	
-CHOICE <i>mode</i>	TDD
- DL CCTrCH list	1
-TFCS ID	Not Present
-Time Info (10.3.6.83)	
-Activation Time	"now"
-Duration	Infinite
-Common timeslot info	Not Present
- Downlink DPCH timeslots and codes (10.3.6.32)	
- First individual timeslot info (10.3.6.37)	
- Timeslot Number (10.3.6.84)	
- CHOICE <i>TDD option</i>	3.84 Mcps
- Timeslot number	2
- TFCl existence	True
- Midamble shift and burst type (10.3.6.41)	
- CHOICE <i>TDD option</i>	3.84 Mcps
- CHOICE <i>Burst Type</i>	Type 1
- Midamble Allocation Mode	Default
- Midamble configuration burst type 1 and 3	16
- Midamble shift	Not present
- CHOICE <i>TDD option</i>	3.84 Mcps
- First timeslot channelisation codes (10.3.6.17)	
- CHOICE <i>codes representation</i>	Consecutive codes
- First channelisation code	16/1
- Last channelisation code	16/2
- CHOICE <i>more timeslots</i>	No more timeslots
- SCCPCH information for FACH (10.3.6.70)	Not Present

MEASUREMENT REPORT message for Inter frequency test cases

This message is common for all inter frequency test cases in clause 8.7 and is described in Annex I.

8.3.3.5 Test requirements

For the test to pass, the total number of successful tests shall be more than 90% of the cases with a confidence level of 95 %.

NOTE: If the above Test Requirement differs from the Minimum Requirement then the Test Tolerance applied for this test is non-zero. The Test Tolerance for this test is defined in clause F.2 and the explanation of how the Minimum Requirement has been relaxed by the Test Tolerance is given in clause F.4.

8.3.4 Inter-system Handover from UTRAN FDD to GSM

8.3.4.1 Definition and applicability

The UTRAN to GSM cell handover delay is defined as the time from the end of the last TTI containing an RRC message implying hard handover to the transmission on the channel of the new RAT.

The requirements and this test apply to the combined FDD and GSM UE.

8.3.4.2 Minimum requirement

The UE shall begin to send access bursts on the new DCCH of the target cell less than 100 ms from the beginning of time period T3.

The rate of correct handovers observed during repeated tests shall be at least 90%.

NOTE: The test requirement in this case is expressed as:

$$T_{\text{Handover delay}} = 90 \text{ ms (Table 8.3.4.1)} + T_{\text{offset}} + T_{\text{UL}}$$

T_{offset} : Equal to 4.65 ms, GSM timing uncertainty between the time from when the UE is ready to transmit until the start of the next time-slot in GSM 26 multiframe structure

T_{UL} : Equal to 4.65 ms, the time the UE has to wait in case the next timeslot is an idle frame or a SACCH frame.

This gives a total of 99.3 ms, allow 100 ms in the test case.

Table 8.3.4.1: FDD/GSM handover - handover delay

UE synchronisation status	handover delay [ms]
The UE has synchronised to the GSM cell before the HANDOVER FROM UTRAN COMMAND is received	90
The UE has not synchronised to the GSM cell before the HANDOVER FROM UTRAN COMMAND is received	190

Table 8.3.4.2: FDD/GSM handover - interruption time

Synchronisation status	Interruption time [ms]
The UE has synchronised to the GSM cell before the HANDOVER FROM UTRAN COMMAND is received	40
The UE has not synchronised to the GSM cell before the HANDOVER FROM UTRAN COMMAND is received	140

The normative reference for this requirement is TS 25.133 [2] clauses 5.4.2 and A.5.4.

8.3.4.3 Test purpose

To verify that the UE meets the minimum requirement.

8.3.4.4 Method of test

8.3.4.4.1 Initial conditions

Test environment: normal; see clauses G.2.1 and G.2.2.

Frequencies to be tested: mid range; see clause G.2.4.

The test parameters are given in table 8.3.4.3, 8.3.4.4 and 8.3.4.5 below. In the measurement control information it is indicated to the UE that event-triggered reporting with Event 3C shall be used.. The test consists of three successive time periods, with a time duration of T1, T2 and T3 respectively. At the start of time duration T1, the UE may not have any timing information of cell 2.

The UTRAN shall send a HANDOVER FROM UTRAN COMMAND with activation time "now". In the GSM Handover command contained in that message, the IE starting time shall not be included. The RRC HANDOVER FROM UTRAN COMMAND message shall be sent to the UE. The start of T3 is defined as the end of the last TTI, containing the HO command.

The requirements are also applicable for a UE not requiring compressed mode, in which case no compressed mode pattern should be sent for the parameters specified in table 8.3.4.3.

Table 8.3.4.3: General test parameters for Correct reporting of GSM neighbours in AWGN propagation condition

Parameter	Unit	Value	Comment
DCH parameters		Conversational / speech / UL:12.2 DL:12.2 kbps / CS RAB + UL:3.4 DL:3.4 kbps	As specified in TS 34.108 clause 6.10.2.4.1.4
Power Control		On	
Target quality value on DTCH	BLER	0.001	
Compressed mode patterns			Only applicable for UE requiring compressed mode patterns
- GSM carrier RSSI measurement		DL Compressed mode reference pattern 2 in Set 2	As specified in clause C.5, table C.5.2
- GSM Initial BSIC identification		Pattern 2	As specified in clause TS 25.133 [2] 8.1.2.5.2.1 table 8.7.
- GSM BSIC re- confirmation		Pattern 2	As specified in clause TS 25.133 [2] 8.1.2.5.2.2 table 8.8.
Active cell		Cell 1	
Inter-RAT measurement quantity		GSM Carrier RSSI	
BSIC verification required		Required	
Threshold other system	dBm	-80	Absolute GSM carrier RSSI threshold for event 3B and 3C.
Hysteresis	dB	0	
Time to Trigger	ms	0	
Filter coefficient		0	
Monitored cell list size		24 FDD neighbours on Channel 1 6 GSM neighbours including the ARFCN of cell 2	NOTE: See Annex I for cell information . The information is sent before the compressed mode patterns starts.
N Identify abort		66	Taken from TS 25.133 [2] 8.1.2.5.2.1 table 8.7.
T Reconfirm abort		5.5	Based on TS 25.133 [2] 8.1.2.5.2.2 table 8.8, rounded up due to 0.5 seconds quantization, as specified in section 10.3.6.33 of TS 25.331 [8]
T1	s	20	
T2	s	5	
T3	s	5	

Table 8.3.4.4: Cell Specific Parameters for Handover UTRAN to GSM cell case (cell 1)

Parameter	Unit	Cell 1 (UTRA)
		T1, T2, T3
CPICH_Ec/I _{or}	dB	-10
PCCPCH_Ec/I _{or}	dB	-12
SCH_Ec/I _{or}	dB	-12
PICH_Ec/I _{or}	dB	-15
DCH_Ec/I _{or}	dB	Note 1
OCNS_Ec/I _{or}	dB	Note 2
\hat{I}_{or}/I_{oc}	dB	0
I_{oc}	dBm/3.84 MHz	-70
CPICH_Ec/I _o	dB	-13
Propagation Condition		AWGN
Q _{rxlevmin}	dBm	-115
NOTE 1: The DPCH level is controlled by the power control loop		
NOTE 2: The power of the OCNS channel that is added shall make the total power from the cell to be equal to I _{or} .		

Table 8.3.4.5: Cell Specific Parameters for Handover UTRAN to GSM cell case (cell 2)

Parameter	Unit	Cell 2 (GSM)	
		T1	T2, T3
Absolute RF Channel Number		ARFCN 1	
RXLEV	dBm	-85	-75

8.3.4.4.2 Procedure

- 1) The RF parameters for cell 1 are set up according to T1 in Table 8.3.4.4.
- 2) The UE is switched on.
- 3) A call is set up according to the test procedure specified in TS 34.108 [3] subclause 7.3.7. For UEs that require compressed mode, the compressed mode parameters are configured as in the table 8.3.4.3. The compressed mode shall remain inactive. Data shall be sent on the DTCH on the UTRA cell throughout the call.
- 4) The RF parameters for cell 2 are set up according to T1 in Table 8.3.4.6 and the SS configures a traffic channel.
- 5) The start of T1 is TTI aligned.
- 6) SS shall transmit PHYSICAL CHANNEL RECONFIGURATION message.
- 7) UE shall transmit PHYSICAL CHANNEL RECONFIGURATION COMPLETE message.
- 8) The SS shall transmit a MEASUREMENT CONTROL message on cell 1.
- 9) At the T1-T2 transition, the SS shall switch the power of cell 2 as in Table 8.3.4.6.
- 10) The UE shall transmit a MEASUREMENT REPORT message triggered by event 3C.
- 11) The SS shall transmit a HANDOVER FROM UTRAN COMMAND message with activation time "now" and indicating the traffic channel of the target GSM cell to the UE through DCCH of the serving UTRAN cell. The start of T3 is defined as the end of the last TTI, containing the HANDOVER command.
- 12) The UE shall transmit a burst on the traffic channel of cell 2 implying that it has switched to the GSM cell. The UE sends a HANDOVER ACCESS message. If the UE transmits access bursts on the new DCCH of the target cell less than 100 ms from the beginning of time period T3, then the number of successful tests is increased by one.
- 13) At the end of T3 SS shall end the call and UE is switched off. Any timing information of cell 2 is deleted in the UE.
- 14) Repeat step 1-13 until the confidence level according to annex F.6.2 is achieved.

Specific Message Contents

All messages indicated above shall use the same content as described in the default message content in clause 9 of 34.108 [3], with the following exceptions:

PHYSICAL CHANNEL RECONFIGURATION message for Inter Rat measurement (step 6):

Information Element	Value/Remark	Version
Message Type (10.2.22)		
UE Information Elements		
-RRC transaction identifier	0	
-Integrity check info		
-message authentication code	SS calculates the value of MAC-I for this message and writes to this IE. The first/ leftmost bit of the bit string contains the most significant bit of the MAC-I.	
-RRC message sequence number	SS provides the value of this IE, from its internal counter.	
-Integrity protection mode info	Not Present	
-Ciphering mode info	Not Present	
-Activation time	Not Present	
-New U-RNTI	Not Present	
-New C-RNTI	Not Present	
-RRC State Indicator	CELL_DCH	
-UTRAN DRX cycle length coefficient	Not Present	
CN Information Elements		
-CN Information info	Not Present	
UTRAN mobility information elements		
-URA identity	Not Present	
RB information elements		
-Downlink counter synchronisation info	Not Present	
PhyCH information elements		
-Frequency info (10.3.6.36)	Not Present	
Uplink radio resources		
-Maximum allowed UL TX power	33 dBm	
-CHOICE <i>channel requirement</i>	Not Present	
Downlink radio resources		
-CHOICE <i>mode</i>	FDD	
-Downlink PDSCH information	Not Present	R99 and Rel-4 only
-Downlink information common for all radio links (10.3.6.24)		
-Downlink DPCH info common for all RL (10.3.6.18)	Not Present	
-CHOICE <i>mode</i>	FDD	
-DPCH compressed mode info (10.3.6.33)	(1/3 TGPS)	
- Transmission gap pattern sequence	1	
- TGPSI	deactivate	
- TGPS Status Flag		
- Transmission gap pattern sequence configuration parameters		
-TGMP	GSM carrier RSSI measurement	
-TGPRC	Infinity	
-TGSN	4	
-TGL1	7	
-TGL2	Not Present	
-TGD	UNDEFINED	
-TGPL1	12	
-TGPL2	Not Present	R99 and Rel-4 only
-RPP	mode 0	
-ITP	mode 0	
-CHOICE UL/DL mode	UL and DL	
-Downlink compressed mode method	SF/2	
-Uplink compressed mode method	SF/2	
-Downlink frame type	B	
-DeltaSIR1	3.0	
-DeltaSIRafter1	3.0	
-DeltaSIR2	Not Present	
-DeltaSIRafter2	Not Present	
-N Identify abort	Not Present	
-T Reconfirm abort	Not Present	
- Transmission gap pattern sequence	(2/3 TGPS)	
- TGPSI	2	
- TGPS Status Flag	deactivate	

Information Element	Value/Remark	Version
- Transmission gap pattern sequence configuration parameters		
-TGMP	gsm-initialBSICIdentification	
-TGPRC	Infinity	
-TGSN	4	
-TGL1	7	
-TGL2	Not Present	
-TGD	UNDEFINED	
-TGPL1	8	
-TGPL2	Not Present	
-RPP	mode 0	
-ITP	mode 0	
-CHOICE UL/DL mode	UL and DL	
-Downlink compressed mode method	SF/2	
-Uplink compressed mode method	SF/2	
-Downlink frame type	B	
-DeltaSIR1	3.0	
-DeltaSIRafter1	3.0	
-DeltaSIR2	Not Present	
-DeltaSIRafter2	Not Present	
-N Identify abort	66	
-T Reconfirm abort	Not Present	
- Transmission gap pattern sequence	(3/3 TGPS)	
- TGPSI	3	
- TGPS Status Flag	deactivate	
- Transmission gap pattern sequence configuration parameters		
-TGMP	GSM BSIC re-confirmation	
-TGPRC	Infinity	
-TGSN	4	
-TGL1	7	
-TGL2	Not Present	
-TGD	UNDEFINED	
-TGPL1	8	
-TGPL2	Not Present	
-RPP	mode 0	
-ITP	mode 0	
-CHOICE UL/DL mode	UL and DL	
-Downlink compressed mode method	SF/2	
-Uplink compressed mode method	SF/2	
-Downlink frame type	B	
-DeltaSIR1	3.0	
-DeltaSIRafter1	3.0	
-DeltaSIR2	Not Present	
-DeltaSIRafter2	Not Present	
-N Identify abort	Not Present	
-T Reconfirm abort	5.5	
-SSDT information (10.3.6.77)	Not Present	R99 and Rel-4 only
-Default DPCH Offset Value (10.3.6.16)	Not Present	
-Downlink information per radio link list	1	
-Downlink information for each radio link (10.3.6.27)		
-CHOICE mode	FDD	
-Primary CPICH info (10.3.6.60)		
-Primary scrambling code	100	
-PDSCH with SHO DCH info (10.3.6.47)	Not Present	R99 and Rel-4 only
-PDSCH code mapping (10.3.6.43)	Not Present	R99 and Rel-4 only
-Downlink DPCH info for each RL (10.3.6.21)		
-CHOICE mode	FDD	
-Primary CPICH usage for channel estimation	Primary CPICH may be used	
-DPCH frame offset	Set to value Default DPCH Offset Value (as currently stored in SS) mod 38400	
-Secondary CPICH info	Not Present	
-DL channelisation code		
-Secondary scrambling code	Not Present	
-Spreading factor	128	
-Code number	96	

Information Element	Value/Remark	Version
-Scrambling code change -TPC combination index -SSDT Cell Identity -Closed loop timing adjustment mode -SCCPCH information for FACH (10.3.6.70)	No change 0 Not Present Not Present Not Present	R99 and Rel-4 only

MEASUREMENT CONTROL message (step 8):

Information Element/Group name	Value/Remark
Message Type (10.2.17)	
UE information elements	
-RRC transaction identifier -Integrity check info	0
-message authentication code -RRC message sequence number	SS calculates the value of MAC-I for this message and writes to this IE. The first/ leftmost bit of the bit string contains the most significant bit of the MAC-I. SS provides the value of this IE, from its internal counter.
Measurement Information elements	
-Measurement Identity -Measurement Command (10.3.7.46) -Measurement Reporting Mode (10.3.7.49) -Measurement Report Transfer Mode -Periodical Reporting / Event Trigger Reporting Mode -Additional measurements list (10.3.7.1)	2 Setup AM RLC Event trigger Not Present
-CHOICE <i>Measurement type</i> -Inter-RAT measurement (10.3.7.27) -Inter-RAT measurement objects list (10.3.7.23) -Inter-RAT measurement quantity (10.3.7.29) -Measurement quantity for UTRAN quality estimate (10.3.7.38) -Filter coefficient -CHOICE mode -Measurement quantity -CHOICE system -Measurement quantity -Filter coefficient -BSIC verification required -Inter-RAT reporting quantity (10.3.7.32) - UTRAN estimated quality - CHOICE system - Observed time difference to GSM cell reporting indicator - GSM Carrier RSSI reporting indicator -Reporting cell status (10.3.7.61) -CHOICE report criteria -Inter-RAT measurement reporting criteria (10.3.7.30) -Parameters required for each event -Inter-RAT event identity (10.3.7.24) -Threshold own system -W -Threshold other system -Hysteresis -Time to trigger -CHOICE reported cell -Maximum number of reported cells	Inter-RAT measurement Not Present 0 FDD CPICH Ec/N0 GSM GSM Carrier RSSI 0 Required FALSE GSM FALSE FALSE Inter-RAT measurement reporting criteria 1 Event 3C Not Present Not Present -80 dBm 0 dB 0 ms Report cells within active set or within virtual active set or of the other RAT 2
Physical channel information elements	
-DPCH compressed mode status info (10.3.6.34)	Active (for all three patterns specified in table 8.3.4.3)

HANDOVER FROM UTRAN COMMAND message (step 11):

Information Element	Value/remark
Message Type (10.2.15)	
UE information elements	
-RRC transaction identifier	0
-Integrity check info	SS calculates the value of MAC-I for this message and writes to this IE. The first/ leftmost bit of the bit string contains the most significant bit of the MAC-I.
-message authentication code	SS provides the value of this IE, from its internal counter.
-RRC message sequence number	now
-Activation time	
RB information elements	
-RAB information list	1
-RAB Info	
- RAB identity	0000 0001B The first/ leftmost bit of the bit string contains the most significant bit of the RAB identity.
- CN domain identity	CS domain
- NAS Synchronization Indicator	Not present
- Re-establishment timer	Use T315
Other information elements	
-CHOICE System type	GSM
-Frequency Band	Set to "GSM/ PCS 1900" if GSM/ PCS 1900 is used in this test. Otherwise set to "GSM/DCS 1800 Band"
-CHOICE GSM message	Single GSM message
-Single GSM message	GSM HANDOVER COMMAND formatted and coded according to GSM specifications as BIT STRING (1..512). The first/ <i>leftmost/ most significant</i> bit of the bit string contains bit 8 of the first octet of the GSM message. The contents of the HANDOVER COMMAND see next table.

HANDOVER COMMAND

Information Element (GSM)	Value/remark	Version
Protocol Discriminator	RR Management.	
Skip Indicator	0000	
Message Type	00101011	
Cell Description - Network Colour Code - Base station Colour Code - BCCH Carrier Number	1 5 BCCH ARFCN of cell A as defined in the initial conditions in clause 26.6.5.1 of TS 51.010-1 [25] for the GSM band under test.	
Channel Description 2 - Channel Type and TDMA offset - Timeslot Number - Training Sequence Code - Hopping - ARFCN	TCH/F + FACCH/F and SACCH/F Chosen arbitrarily by the test house, but not Zero. Chosen arbitrarily by the test house. Single RF channel. BCCH ARFCN of cell A as defined in the initial conditions in clause 26.6.5.1 of TS 51.010-1 [25] for the GSM band under test.	
Handover Reference - Handover Reference Value	Chosen arbitrarily by the test house.	
Power Command and ACCESS Type - ATC - EPC_mode - FPC - EPC_FPC - Power level	0 0 0 0 Chosen arbitrarily by the test house.	REL-5 R99 and REL-4 only REL-5
Synchronization Indication	Not present.	
Channel Mode	speech full rate or half rate version 1	
All other information elements	Not present.	

MEASUREMENT REPORT message for Inter-RAT test cases

This message is common for all inter RAT-frequency test cases and is described in Annex I.

8.3.4.5 Test requirements

Table 8.3.4.6: Cell Specific Parameters for Handover UTRAN to GSM cell case (cell 2), test requirements

Parameter	Unit	Cell 2 (GSM)	
		T1	T2, T3
Absolute RF Channel Number		BCCH ARFCN of cell A as defined in the initial conditions in clause 26.6.5.1 of TS 51.010-1 [25] for the GSM band under test.	
RXLEV	dBm	-85	-74

For the test to pass, the total number of successful tests shall be more than 90% of the cases with a confidence level of 95 %.

NOTE: If the above Test Requirement differs from the Minimum Requirement then the Test Tolerance applied for this test is non-zero. The Test Tolerance for this test is defined in clause F.2 and the explanation of how the Minimum Requirement has been relaxed by the Test Tolerance is given in clause F.4.

8.3.5 Cell Re-selection in CELL_FACH

8.3.5.1 One frequency present in neighbour list

8.3.5.1.1 Definition and applicability

The cell re-selection delay is defined as the time between the occurrence of an event which will trigger Cell Reselection process and the moment in time when the UE starts sending the the preambles on the PRACH for sending RRC CELL UPDATE message to the UTRAN.

The requirements and this test apply to the FDD UE.

8.3.5.1.2 Minimum requirements

The cell re-selection delay shall be less than 1.6 s.

The rate of correct cell reselections observed during repeated tests shall be at least 90%.

If a cell has been detectable at least $T_{\text{identify,intra}}$, the cell reselection delay in CELL_FACH state to a cell in the same frequency shall be less than

$$T_{\text{reselection,intra}} = T_{\text{Measurement_Period Intra}} + T_{\text{IU}} + 20 + T_{\text{SI}} + T_{\text{RA}} \text{ ms}$$

where

$$T_{\text{Measurement_Period Intra}} = 200 \text{ ms.}$$

T_{IU} is the interruption uncertainty when changing the timing from the old to the new cell. T_{IU} can be up to one frame (10 ms).

T_{SI} = The time required for receiving all the relevant system information data according to the reception procedure and the RRC procedure delay of system information blocks defined in 25.331 for a UTRAN cell. 1280 ms is assumed in this test case.

T_{RA} = The additional delay caused by the random access procedure. T_{RA} is a delay is caused by the physical random access procedure described in TS 25.214 clause 6.1. A persistence value is assumed to be 1 in this test case and therefore T_{RA} in this test case is 40 ms.

These requirements assume radio conditions to be sufficient, so reading of system information can be done without errors.

The normative reference for this requirement is TS 25.133 [2] clauses 5.5.2.1.1 and A.5.5.1.

8.3.5.1.3 Test purpose

The purpose of this test is to verify the requirement for the cell re-selection delay in CELL_FACH state in the single carrier case

8.3.5.1.4 Method of test

8.3.5.1.4.1 Initial conditions

Test environment: normal; see clauses G.2.1 and G.2.2.

Frequencies to be tested: mid range; see clause G.2.4.

The test parameters are given in table 8.3.5.1.1 to 8.3.5.1.5. The UE is requested to monitor neighbouring cells on 1 carrier. The maximum repetition period of the relevant system info blocks that needs to be received by the UE to camp on a cell shall be 1280 ms.

Table 8.3.5.1.1: General test parameters for Cell Re-selection in CELL_FACH, one freq. in neighbour list

Parameter		Unit	Value	Comment
Initial condition	Active cell		Cell2	
	Neighbour cells		Cell1, Cell3, Cell4, Cell5, Cell6	
Final condition	Active cell		Cell1	
Access Service Class (ASC#0) – Persistence value		-	1	Selected so that no additional delay is caused by the random access procedure. The value shall be used for all cells in the test.
HCS				Not used
T _{SI}		ms	1280	See Annex I for the SIB repetition period of system information blocks.
T1		s	15	
T2		s	15	

The transport and physical parameters of the S-CCPCH carrying the FACH are defined in TS 34.108 [3] clause 6.1.0b(Contents of System Information Block type 5 (FDD)).

Table 8.3.5.1.2: void

Table 8.3.5.1.3: void

Table 8.3.5.1.4: Cell specific conditions for Cell Re-selection in CELL_FACH, one freq. in neighbour list

Parameter	Unit	Cell 1		Cell 2		Cell 3		Cell 4		Cell 5		Cell 6	
		T1	T2	T1	T2	T1	T2	T1	T2	T1	T2	T1	T2
UTRA RF Channel Number		Channel 1		Channel 1		Channel 1		Channel 1		Channel 1		Channel 1	
CPICH_Ec/I _{or}	dB	-10		-10		-10		-10		-10		-10	
PCCPCH_Ec/I _{or}	dB	-12		-12		-12		-12		-12		-12	
SCH_Ec/I _{or}	dB	-12		-12		-12		-12		-12		-12	
PICH_Ec/I _{or}	dB	-15		-15		-15		-15		-15		-15	
S-CCPCH_Ec/I _{or}	dB	-12		-12		-12		-12		-12		-12	
OCNS_Ec/I _{or}	dB	-1.295		-1.295		-1.295		-1.295		-1.295		-1.295	
\hat{I}_{or} / I_{oc}	dB	7.3	10.27	10.27	7.3	0.27	0.27	0.27	0.27	0.27	0.27	0.27	0.27
\hat{I}_{or} (Note 1)	dBm	-62.73	-59.73	-59.73	-62.73	-69.73	-69.73	-69.73	-69.73	-69.73	-69.73	-69.73	-69.73
	dBm/3.84 MHz	-70											
CPICH_Ec/I _o	dB	-16	-13	-13	-16	-23	-23	-23	-23	-23	-23	-23	-23
Propagation Condition		AWGN											
Cell_selection_and_reselection_quality_measure		CPICH E _c /N ₀		CPICH E _c /N ₀		CPICH E _c /N ₀		CPICH E _c /N ₀		CPICH E _c /N ₀		CPICH E _c /N ₀	
Qqualmin	dB	-20		-20		-20		-20		-20		-20	
Qrxlevmin	dBm	-115		-115		-115		-115		-115		-115	
UE_TXPWR_MAX_RACH	dBm	21		21		21		21		21		21	
Qoffset 2 _{s, n}	dB	C1, C2: 0 C1, C3: 0 C1, C4: 0 C1, C5: 0 C1, C6: 0	C2, C1: 0 C2, C3: 0 C2, C4: 0 C2, C5: 0 C2, C6: 0	C3, C1: 0 C3, C2: 0 C3, C4: 0 C3, C5: 0 C3, C6: 0	C4, C1: 0 C4, C2: 0 C4, C3: 0 C4, C5: 0 C4, C6: 0	C5, C1: 0 C5, C2: 0 C5, C3: 0 C5, C4: 0 C5, C6: 0	C6, C1: 0 C6, C2: 0 C6, C3: 0 C6, C4: 0 C6, C5: 0						
Qhyst	dB	0		0		0		0		0		0	
Treselection	s	0		0		0		0		0		0	
Sintrasearch	dB	not sent		not sent		not sent		not sent		not sent		not sent	
IE "FACH Measurement occasion info"		not sent		not sent		not sent		not sent		not sent		not sent	

NOTE 1: The nominal \hat{I}_{or} values, although not explicitly defined in 25.133 [2] are added here since they are implied and need to be identified so that the test equipment can be configured.

8.3.5.1.4.2 Procedure

- 1) The SS activates cell 1-6 with RF parameters set up according to T1 in table 8.3.5.1.5.
- 2) The UE is switched on.
- 3) An RRC connection is set up according to the signalling sequence in the generic set-up procedure specified in TS 34.108 [3] subclause 7.3.5 to place the UE in the CELL_FACH state on Cell 2 and the SS waits for this process to complete.
- 4) After 15 seconds from completion of step 3 or the beginning of T1, the parameters are changed to those defined for T2 in table 8.3.5.1.5.
- 5) If the UE responds on Cell 1 with a PRACH (CELL UPDATE message cause "cell reselection") within 1.84 s, then the success is recorded, the SS shall transmit a CELL UPDATE CONFIRM message and then the procedure moves to step 7.
- 6) Since the UE has failed to respond with the correct message within the allowed time, a failure is recorded. The SS shall then wait for a total of 15 s from the beginning of T2 and if no response is received, the UE shall be switched off and the procedure returns to step 1. Otherwise the SS shall transmit a CELL UPDATE CONFIRM message and then the procedure continues with step 7.
- 7) After total of 15 s from the beginning of T2, the parameters are changed to those defined for T1 in table 8.3.5.1.5.
- 8) If the UE responds on Cell 2 with a PRACH (CELL UPDATE message cause "cell reselection") within 1.84 s, then a success is recorded and the procedure moves to step 10.
- 9) Since the UE has failed to respond with the correct message within the allowed time, a failure is recorded. The SS shall then wait for a total of 15 s from the beginning of T1 and if no response is received the UE shall be switched off and the procedure returns to step 1. Otherwise the SS shall transmit a CELL UPDATE CONFIRM message and then the procedure continues with step 10.
- 10) Steps 4 to 10 are repeated until the confidence level according to annex F.6.2 is achieved.

NOTE 1: The time required for receiving all the relevant system information data according to the reception procedure and the RRC procedure delay of system information blocks defined in 25.331 for a UTRAN cell. Since the maximum time to read the relevant system info blocks that needs to be received by the UE to camp on a cell is 1420ms (see note 2) and the maximum RRC procedure delay for reception system information block is 100ms, 1520 ms is assumed in this test case. Therefore the cell re-selection delay shall be less than 1.84 s. (Minimum requirement + 240ms). Specific Message Contents

NOTE 2: The maximum repetition period of the relevant system info blocks that needs to be received by the UE to camp on a cell is 1280ms. The Master Information Block (MIB) is repeated every 8 frame and SIB5 (and SIB11) is segmented into 4 segments where the first segment is scheduled adjacent to the MIB at SIB_POS=40 and the other three segments are scheduled after the MIB (SIB_POS=42, 44 and 46). The maximum time for a UE to read SIB5 will occur if the UE start reading the BCH at the SFN after the MIB located prior to the first segment of SIB5 (SIB_POS 32). Then the UE will not be able to read SIB5 until the second occurrence of SIB5, which will happen at SIB_POS 46 + 1280ms. This gives that the maximum time for the UE to read the relevant system info will be 1420ms ((SIB_POS 46 – SIB_POS 32)*10ms + 1280ms).

All messages indicated above shall use the same content as described in the default message content in clause 9 of 34.108 [3], with the following exceptions:

Contents of CELL UPDATE CONFIRM message for CELL_FACH

Information Element	Value/remark
RRC transaction identifier	0
Activation time	Not Present
New C-RNTI	1010101010101010 B
RRC State indicator	CELL_FACH

8.3.5.1.5 Test requirements

For the test to pass, the total number of successful attempts shall be more than 90% of the cases with a confidence level of 95 %.

Table 8.3.5.1.5: Cell specific test requirements for Cell Re-selection in CELL_FACH, one freq. in neighbour list

Parameter	Unit	Cell 1		Cell 2		Cell 3		Cell 4		Cell 5		Cell 6	
		T1	T2	T1	T2	T1	T2	T1	T2	T1	T2	T1	T2
UTRA RF Channel Number		Channel 1		Channel 1		Channel 1		Channel 1		Channel 1		Channel 1	
CPICH_Ec/lor	dB	-9.4		-9.4		-10.5		-10.5		-10.5		-10.5	
PCCPCH_Ec/lor	dB	-11.4		-11.4		-12.5		-12.5		-12.5		-12.5	
SCH_Ec/lor	dB	-11.4		-11.4		-12.5		-12.5		-12.5		-12.5	
PICH_Ec/lor	dB	-14.4		-14.4		-15.5		-15.5		-15.5		-15.5	
S-CCPCH_Ec/lor	dB	-11.4		-11.4		-12.5		-12.5		-12.5		-12.5	
OCNS_Ec/lor	dB	-1.52		-1.52		-1.13		-1.13		-1.13		-1.13	
\hat{I}_{or}/I_{oc} Note 1	dB	7.0	10.4	10.4	7.0	0.3	0.3	0.3	0.3	0.3	0.3	0.3	
\hat{I}_{or}	dBm	-63.0	-59.6	-59.6	-63.0	-69.7	-69.7	-69.7	-69.7	-69.7	-69.7	-69.7	
I_{oc}	dBm/3.84 MHz	-70											
CPICH_Ec/lor Note 1	dB	-15.7	-12.3	-12.3	-15.7	-23.5	-23.5	-23.5	-23.5	-23.5	-23.5	-23.5	

All other parameters and conditions specified in table 8.3.5.1.4 are unchanged.

NOTE 1: These parameters are not directly settable, but are derived by calculation from the settable parameters.

NOTE 2: If the above Test Requirement differs from the Minimum Requirement then the Test Tolerance applied for this test is non-zero. The Test Tolerance for this test is defined in clause F.2 and the explanation of how the Minimum Requirement has been relaxed by the Test Tolerance is given in clause F.4.

8.3.5.2 Two frequencies present in the neighbour list

8.3.5.2.1 Definition and applicability

The cell re-selection delay is defined as the time between the occurrence of an event which will trigger Cell Reselection process and the moment in time when the UE starts sending the preambles on the PRACH for sending RRC CELL UPDATE message to the UTRAN.

The requirements and this test apply to the FDD UE.

8.3.5.2.2 Minimum requirements

The cell re-selection delay shall be less than 1.9 s.

The rate of correct cell reselections observed during repeated tests shall be at least 90%.

If a cell has been detectable at least $T_{\text{identify,inter}}$, the cell reselection delay in CELL_FACH state to a FDD cell on a different frequency shall be less than

$$T_{\text{reselection,inter}} = T_{\text{Measurement inter}} + T_{\text{IU}} + 20 + T_{\text{SI}} + T_{\text{RA}} \text{ ms}$$

where

$T_{\text{Measurement inter}}$ is 480 ms in this case

T_{IU} is the interruption uncertainty when changing the timing from the old to the new cell. T_{IU} can be up to one frame (10 ms).

T_{SI} = The time required for receiving all the relevant system information data according to the reception procedure and the RRC procedure delay of system information blocks defined in 25.331 for a UTRAN cell. 1280 ms is assumed in this test case.

T_{RA} = The additional delay caused by the random access procedure. T_{RA} is a delay is caused by the physical random access procedure described in TS 25.214 clause 6.1. A persistence value is assumed to be 1 in this test case and therefore T_{RA} in this test case is 40 ms.

These requirements assume radio conditions to be sufficient, so that reading of system information can be done without errors.

The normative reference for this requirement is TS 25.133 [2] clauses 5.5.2.1.2 and A.5.5.2.

8.3.5.2.3 Test purpose

The purpose of this test is to verify the requirement for the cell re-selection delay in CELL_FACH state in the single carrier case

8.3.5.2.4 Method of test

8.3.5.2.4.1 Initial conditions

Test environment: normal; see clauses G.2.1 and G.2.2.

Frequencies to be tested: mid range; see clause G.2.4.

The test parameters are given in table 8.3.5.2.1 to 8.3.5.2.5. The UE is requested to monitor neighbouring cells on 2 carriers. The maximum repetition period of the relevant system info blocks that needs to be received by the UE to camp on a cell shall be 1 280 ms

Table 8.3.5.2.1: General test parameters for Cell Re-selection in CELL_FACH, two freqs. in neighbour list

Parameter		Unit	Value	Comment
Initial condition	Active cell		Cell2	
	Neighbour cells		Cell1, Cell3, Cell4, Cell5, Cell6	
Final condition	Active cell		Cell1	
Access Service Class (ASC#0) – Persistence value		-	1	Selected so that no additional delay is caused by the random access procedure. The value shall be used for all cells in the test.
HCS				Not used
T_{SI}		ms	1280	See Annex I for the SIB repetition period of system information blocks.
T1		s	15	
T2		s	15	

NOTE: Monitored cell list size has 6 cells on 2 carriers. See Annex I for the cell information.

The transport and physical parameters of the S-CCPCH carrying the FACH are defined in TS 34.108 [3] clause 6.1.0b (Contents of System Information Block type 5 (FDD)).

Table 8.3.5.2.2: void

Table 8.3.5.2.3: void

Table 8.3.5.2.4: Cell specific conditions for Cell re-selection in CELL_FACH state, two freqs. in neighbour list

Parameter	Unit	Cell 1		Cell 2		Cell 3		Cell 4		Cell 5		Cell 6	
		T1	T2	T1	T2	T1	T2	T1	T2	T1	T2	T1	T2
UTRA RF Channel Number		Channel 1		Channel 2		Channel 1		Channel 1		Channel 2		Channel 2	
CPICH_Ec/Ior	dB	-10		-10		-10		-10		-10		-10	
PCCPCH_Ec/Ior	dB	-12		-12		-12		-12		-12		-12	
SCH_Ec/Ior	dB	-12		-12		-12		-12		-12		-12	
PICH_Ec/Ior	dB	-15		-15		-15		-15		-15		-15	
S-CCPCH_Ec/Ior	dB	-12		-12		-12		-12		-12		-12	
OCNS_Ec/Ior	dB	-1.295		-1.295		-1.295		-1.295		-1.295		-1.295	
\hat{I}_{or}/I_{oc}	dB	-1.8	2.2	2.2	-1.8	-6.8	-4.8	-6.8	-4.8	-4.8	-6.8	-4.8	-6.8
\hat{I}_{or} (Note 1)	dBm	-71.85	-67.75	-67.75	-71.85	-76.85	-74.75	-76.85	-74.75	-74.75	-76.85	-74.75	-76.85
I_{oc}	dBm/3.84 MHz	-70											
CPICH_Ec/Io	dB	-15	-13	-13	-15	-20		-20		-20		-20	
Propagation Condition		AWGN											
Cell_selection_and_reselection_quality_measure		CPICH E _c /N ₀		CPICH E _c /N ₀		CPICH E _c /N ₀		CPICH E _c /N ₀		CPICH E _c /N ₀		CPICH E _c /N ₀	
Qqualmin	dB	-20		-20		-20		-20		-20		-20	
Qrxlevmin	dBm	-115		-115		-115		-115		-115		-115	
UE_TXPWR_MAX_RACH	dBm	21		21		21		21		21		21	
Qoffset2 _{s, n}	dB	C1, C2: 0 C1, C3: 0 C1, C4: 0 C1, C5: 0 C1, C6: 0	C2, C1: 0 C2, C3: 0 C2, C4: 0 C2, C5: 0 C2, C6: 0	C3, C1: 0 C3, C2: 0 C3, C4: 0 C3, C5: 0 C3, C6: 0	C4, C1: 0 C4, C2: 0 C4, C3: 0 C4, C5: 0 C4, C6: 0	C5, C1: 0 C5, C2: 0 C5, C3: 0 C5, C4: 0 C5, C6: 0	C6, C1: 0 C6, C2: 0 C6, C3: 0 C6, C4: 0 C6, C5: 0						
Qhyst2	dB	0		0		0		0		0		0	
Treselection	s	0		0		0		0		0		0	
Sintrasearch	dB	not sent		not sent		not sent		not sent		not sent		not sent	
Sintersearch	dB	not sent		not sent		not sent		not sent		not sent		not sent	
IE "FACH Measurement occasion info"		sent		sent		sent		sent		Sent		sent	
FACH Measurement occasion cycle length coefficient		3		3		3		3		3		3	
Inter-frequency FDD measurement indicator		TRUE		TRUE		TRUE		TRUE		TRUE		TRUE	
Inter-frequency TDD measurement indicator		FALSE		FALSE		FALSE		FALSE		FALSE		FALSE	
NOTE 1: The nominal I _{or} values, although not explicitly defined in 25.133 [2] are added here since they are implied and need to be identified so that the test equipment can be configured.													

8.3.5.2.4.2 Procedure

- 1) The RF parameters for cell 1 are set up according to T1 in table 8.3.5.2.5.
- 2) The UE is switched on.
- 3) An RRC connection is set up according to the signalling sequence in the generic set-up procedure specified in TS 34.108 [3] subclause 7.3.5 to place the UE in the CELL_FACH state on Cell 2 and the SS waits for this process to complete.
- 4) After 15 seconds from completion of step3 or the beginning of T1, the parameters are changed to those defined for T2 in table 8.3.5.2.5.
- 5) If the UE responds on Cell 1 with a PRACH (CELL UPDATE message cause "cell reselection") within 2.14 s, then the success is recorded, the SS shall transmit a CELL UPDATE CONFIRM message and then the procedure moves to step 7.
- 6) Since the UE has failed to respond with the correct message within the allowed time, a failure is recorded. The SS shall then wait for a total of 15 s from the beginning of T2 and if no response is received, the UE shall be switched off and the procedure returns to step 1. Otherwise the SS shall transmit a CELL UPDATE CONFIRM message and then the procedure continues with step 7.
- 7) After total of 15 s from the beginning of T2, the parameters are changed to those defined for T1 in table 8.3.5.2.5.
- 8) If the UE responds on Cell 2 with a PRACH (CELL UPDATE message cause "cell reselection") within 2.14 s, then a success is recorded and the procedure moves to step 10.
- 9) Since the UE has failed to respond with the correct message within the allowed time, a failure is recorded. The SS shall then wait for a total of 15 s from the beginning of T1 and if no response is received the UE shall be switched off and the procedure returns to step 1. Otherwise the SS shall transmit a CELL UPDATE CONFIRM message and then the procedure continues with step 10.
- 10) Steps 4 to 10 are repeated until the confidence level according to annex F.6.2 is achieved.

NOTE 1: The time required for receiving all the relevant system information data according to the reception procedure and the RRC procedure delay of system information blocks defined in 25.331 for a UTRAN cell. Since the maximum time to read the relevant system info blocks that needs to be received by the UE to camp on a cell is 1420ms (see note 2) and the maximum RRC procedure delay for reception system information block is 100ms, 1520 ms is assumed in this test case. Therefore the cell re-selection delay shall be less than 2.14 s. (Minimum requirement + 240ms).

NOTE 2: The maximum repetition period of the relevant system info blocks that needs to be received by the UE to camp on a cell is 1280ms. The Master Information Block (MIB) is repeated every 8 frame and SIB5 (and SIB11) is segmented into 4 segments where the first segment is scheduled adjacent to the MIB at SIB_POS=40 and the other three segments are scheduled after the MIB (SIB_POS=42, 44 and 46). The maximum time for a UE to read SIB5 will occur if the UE start reading the BCH at the SFN after the MIB located prior to the first segment of SIB5 (SIB_POS 32). Then the UE will not be able to read SIB5 until the second occurrence of SIB5, which will happen at SIB_POS 46 + 1280ms. This gives that the maximum time for the UE to read the relevant system info will be 1420ms ((SIB_POS 46 – SIB_POS 32)*10ms +1280ms).

Specific Message Contents

All messages indicated above shall use the same content as described in the default message content in clause 9 of 34.108 [3], with the following exceptions:

Contents of CELL UPDATE CONFIRM message for CELL_FACH

Information Element	Value/remark
RRC transaction identifier	0
Activation time	Not Present
New C-RNTI	10101010101010 B
RRC State indicator	CELL_FACH

8.3.5.2.5 Test requirements

For the test to pass, the total number of successful attempts shall be more than 90 % of the cases with a confidence level of 95 %.

Table 8.3.5.2.5: Cell specific test requirements for Cell re-selection in CELL_FACH state, two freqs. in neighbour list

Parameter	Unit	Cell 1		Cell 2		Cell 3		Cell 4		Cell 5		Cell 6	
		T1	T2	T1	T2	T1	T2	T1	T2	T1	T2	T1	T2
UTRA RF Channel Number		Channel 1		Channel 2		Channel 1		Channel 1		Channel 2		Channel 2	
CPICH_Ec/Ior	dB	-9.4		-9.4		-10.7		-10.7		-10.7		-10.7	
PCCPCH_Ec/Ior	dB	-11.4		-11.4		-12.7		-12.7		-12.7		-12.7	
SCH_Ec/Ior	dB	-11.4		-11.4		-12.7		-12.7		-12.7		-12.7	
PICH_Ec/Ior	dB	-14.4		-14.4		-15.7		-15.7		-15.7		-15.7	
S-CCPCH_Ec/Ior	dB	-11.4		-11.4		-12.7		-12.7		-12.7		-12.7	
OCNS_Ec/Ior	dB	-1.52		-1.52		-1.08		-1.08		-1.08		-1.08	
\hat{I}_{or}/I_{oc} Note 1	dB	-1.80	+4.64	+4.64	-1.80	-6.80	-3.16	-6.80	-3.16	-3.16	-6.80	-3.16	-6.80
\hat{I}_{or}	dBm	-71.8	-67.0	-67.0	-71.8	-76.8	-74.8	-76.8	-74.8	-74.8	-76.8	-74.8	-76.8
I_{oc}	dBm/3.84 MHz	-70.0	-71.6	-71.6	-70.0	-70.0	-71.6	-70.0	-71.6	-71.6	-70.0	-71.6	-70.0
CPICH_Ec/Io Note 1	dB	-14.4	-11.6	-11.6	-14.4	-20.7	-20.7	-20.7	-20.7	-20.7	-20.7	-20.7	-20.7

All other parameters and conditions specified in table 8.3.5.2.4 are unchanged.

NOTE 1: These parameters are not directly settable, but are derived by calculation from the settable parameters.

NOTE 2: If the above Test Requirement differs from the Minimum Requirement then the Test Tolerance applied for this test is non-zero. The Test Tolerance for this test is defined in clause F.2 and the explanation of how the Minimum Requirement has been relaxed by the Test Tolerance is given in clause F.4.

8.3.5.3 Cell Reselection to GSM

8.3.5.3.1 Definition and applicability

The cell re-reselection delay is defined as the time from the beginning of time period T2, to the moment when the UE starts to transmit the random access in Cell 2 (the GSM cell).

This requirements and this test apply to UE supporting FDD PS and GSM GPRS.

8.3.5.3.2 Minimum requirements

The cell re-selection delay shall be less than $5.5 + T_{RA}$ s.

The rate of correct reselections observed during repeated tests shall be at least 90%.

NOTE: The cell re-selection delay can be expressed

$$T_{\text{reselection,GSM}} = T_{\text{identify,GSM}} + T_{\text{measurement,GSM}} + 40 + T_{\text{BCCH}} + T_{\text{RA}} \text{ ms}$$

where:

$T_{\text{identify,GSM}}$ Specified in TS 25.133 [2] clause 8.4.2.5.2.1, here it is 2880 ms

$T_{\text{measurement,GSM}}$ Specified in TS 25.133 [2] clause 5.5.2.1.4, here it is 640 ms

T_{BCCH} According to TS 05.08 [20] for R99 and TS 45.008 [30] for Rel-4 and later releases, the maximum time allowed to read the BCCH data, when being synchronized to a BCCH carrier, is 1.9 s.

T_{RA} The additional delay caused by the random access procedure in the GSM cell, is 10 ms (2 GSM radio frames).

These requirements assume radio conditions to be sufficient, so reading of system information can be done without errors.

The normative reference for this requirement is TS 25.133 [2] clauses 5.5.2.1.4 and A.5.5.3.

8.3.5.3.3 Test purpose

The purpose of this test is to verify the requirement for the cell re-selection delay in CELL_FACH state.

8.3.5.3.4 Method of test

8.3.5.3.4.1 Initial conditions

Test environment: normal; see clauses G.2.1 and G.2.2.

Frequencies to be tested: mid range; see clause G.2.4.

The test parameters are given in table 8.3.5.3.1 to 8.3.5.3.5. This scenario implies the presence of 1 UTRAN serving cell, and 1 GSM cell to be re-selected. The UTRAN cell and the GSM cell are set to belong to different location areas. The GSM cell shall be set up to allow the UE to transmit radio access bursts in every GSM radio frame. The UE is requested to monitor neighbouring cells on 1 UMTS carrier and 6 GSM cells. The GSM cell is configured as GSM only (GPRS not active).

Table 8.3.5.3.1: General test parameters for UTRAN to GSM Cell Re-selection

Parameter		Unit	Value	Comment
Initial condition	Active cell		Cell1	
	Neighbour cell		Cell2	
Final condition	Active cell		Cell2	
HCS				Not used
Neighbour cell list size			24 FDD neighbours on Channel 1 6 GSM neighbours including the ARFCN of cell 2	NOTE: See Annex I for cell information.
T1		s	5	
T2		s	10	

The transport and physical parameters of the S-CCPCH carrying the FACH are defined in TS 34.108 [3] clause 6.1.0b (Contents of System Information Block type 5 (FDD)) .

Table 8.3.5.3.2: void

Table 8.3.5.3.3: void

Table 8.3.5.3.4: Cell re-selection UTRAN to GSM cell case (cell 1)

Parameter	Unit	Cell 1 (UTRA)	
		T1	T2
UTRA RF Channel Number		Channel 1	
CPICH_Ec/Ior	dB	-10	
PCCPCH_Ec/Ior	dB	-12	
SCH_Ec/Ior	dB	-12	
PICH_Ec/Ior	dB	-15	
S-CCPCH_Ec/Ior	dB	-12	
OCNS_Ec/Ior	dB	-1.295	
\hat{I}_{or}/I_{oc}	dB	0	-5
I_{oc}	dBm/3.84 MHz	-70	
CPICH_Ec/Io	dB	-13	-16.2
CPICH_RSCP	dBm	-80	-85
Propagation Condition		AWGN	
Cell_selection_and_reselection_quality_measure		CPICH Ec/No	
Qualmin	dB	-20	
Qrxlevmin	dBm	-115	
UE_TXPWR_MAX_RACH	dBm	21	
Qoffset1 _{s,n}	dB	C1, C2: 0	
Qhyst1	dB	0	
Treselection	s	0	
Ssearch _{RAT}	dB	Not sent	
IE "FACH Measurement occasion info"		Sent	
FACH Measurement occasion cycle length coefficient		3	
Inter-frequency FDD measurement indicator		FALSE	
Inter-frequency TDD measurement indicator		FALSE	
Inter-RAT measurement indicators		Included	
>RAT type		GSM	

Table 8.3.5.3.5: Cell re-selection UTRAN to GSM cell case (cell 2)

Parameter	Unit	Cell 2 (GSM)	
		T1	T2
Absolute RF Channel Number		ARFCN 1	
RXLEV	dBm	-90	-75
RXLEV_ACCESS_MIN	dBm	-104	
MS_TXPWR_MAX_CCH	dBm	33	
FDD_Qmin	dB	-14	
Qsearch_I	-	always	

Specific 2 quarter Message Contents

All messages indicated shall use the same content as described in the default message content in TS 05.08 [20] clause 9 for R99 and in TS45.008 [30] clause 9 for Rel-4 and later releases, with the above exceptions.

8.3.5.3.4.2 Procedure

- 1) The SS activates cell 1-2 with RF parameters set up according to T1 in tables 8.3.5.3.6 and 8.3.5.3.7.
- 2) The UE is switched on.

- 3) An RRC connection is set up according to the signalling sequence in the generic set-up procedure specified in TS 34.108 [3] subclause 7.3.8 to place the UE in CELL_FACH and the SS waits for this process to complete. T1 starts.
- 4) After 5 seconds from the beginning of T1, the parameters are changed to those defined for T2 in tables 8.3.5.3.6 and 8.3.5.3.7.
- 5) The SS waits for random access requests from the UE. If the UE responds on cell 2 within 5.51 s (=5.5 s + T_{RAS}) from the beginning of time period T2 then a success is recorded and the SS completes the location update procedure in GSM and the procedure continues with step 7.
- 6) Since the UE has failed to respond with the correct message within the allowed time, a failure is recorded. The SS shall then wait for a total of 10s from the beginning of T2 and if no response is received, the UE shall be switched off and the procedure returns to step 1. Otherwise the SS completes the location update procedure in GSM and the procedure continues with step 7.
- 7) After 10 s from the beginning of time period T2, the parameters are changed to those defined for T1 in tables 8.3.5.3.6 and 8.3.5.3.7.
- 8) The SS waits for random access requests from the UE on cell 1. The SS completes the routing area update procedure in UTRA. T1 starts.
- 9) Repeat step 4) to 8) until the confidence level according to annex F.6.2 is achieved.

8.3.5.3.5 Test requirements

Table 8.3.5.3.6: Cell re-selection UTRAN to GSM cell case (cell 1) Test Requirements

Parameter	Unit	Cell 1 (UTRA)	
		T1	T2
UTRA RF Channel Number		Channel 1	
CPICH_Ec/Ior	dB	-9.9	-10.1
PCCPCH_Ec/Ior	dB	-12	
SCH_Ec/Ior	dB	-12	
PICH_Ec/Ior	dB	-15	
S-CCPCH_Ec/Ior	dB	-12	
OCNS_Ec/Ior	dB	-1.309	-1.282
\hat{I}_{or}/I_{oc}	dB	0.3	-5.3
I_{oc}	dBm/3.84 MHz	-70	
CPICH_Ec/Io	dB	-12.8	-16.5
CPICH_RSCP	dBm	-79.6	-85.4
Propagation Condition		AWGN	
Cell_selection_and_reselection_quality_measure		CPICH Ec/No	
Qqualmin	dB	-20	
Qrxlevmin	dBm	-115	
UE_TXPWR_MAX_RACH	dBm	21	
Qoffset1s,n	dB	C1, C2: 0	
Qhyst1	dB	0	
Treselection	s	0	
Ssearch _{RAT}	dB	Not sent	
IE "FACH Measurement occasion info"		Sent	
FACH Measurement occasion cycle length coefficient		3	
Inter-frequency FDD measurement indicator		FALSE	
Inter-frequency TDD measurement indicator		FALSE	
Inter-RAT measurement indicators		Included	
>RAT type		GSM	

Table 8.3.5.3.7: Cell re-selection UTRAN to GSM cell case (cell 2) Test Requirements

Parameter	Unit	Cell 2 (GSM)	
		T1	T2
Absolute RF Channel Number		BCCH ARFCN of cell A as defined in the initial conditions in clause 26.6.5.1 of TS 51.010-1 [25] for the GSM band under test.	
RXLEV	dBm	-91	-74
RXLEV_ACCESS_MIN	dBm	-104	
MS_TXPWR_MAX_CCH	dBm	33	
FDD_Qmin	dB	-14	
Qsearch_I	-	always	

NOTE 1: CPICH_Ec/No and CPICH_RSCP levels have been calculated from other parameters for information purposes. They are not settable parameters themselves.

For the test to pass, the total number of successful attempts shall be more than 90% of the cases with a confidence level of 95 %.

Note: If the above Test Requirement differs from the Minimum Requirement then the Test Tolerance applied for this test is non-zero. The Test Tolerance for this test is defined in clause F.2 and the explanation of how the Minimum Requirement has been relaxed by the Test Tolerance is given in clause F.4.

8.3.5.4 Cell Reselection during an MBMS session, one frequency present in neighbour list

8.3.5.4.1 Definition and applicability

The purpose of this test is to verify the requirement for the cell identification for UEs in an MBMS PTM session and the required functionality on measurement occasions by use of a cell re-selection test case.

The requirements and this test apply to release 6 and later releases for FDD UE that supports MBMS.

Editor's note: This test is incomplete.

8.3.5.4.2 Minimum requirements

The UE is requested to receive the MBMS service and monitor neighbouring cells on 2 carriers. The maximum repetition period of the relevant system info blocks that needs to be received by the UE to camp on a cell shall be 1280 ms.

The cell re-selection delay shall be less than 1.9s.

During T1 and T2 the MTCH SDU ER shall not exceed 4.0%.

The rate of correct cell reselections observed during repeated tests shall be at least 90%.

NOTE: The cell re-selection delay in this case is expressed as:

$$T_{\text{reselection, inter}} = T_{\text{Measurement, inter}} + T_{\text{IU}} + 20 + T_{\text{SI}} + T_{\text{RA}} \text{ ms,}$$

where:

$T_{\text{Measurement, inter}}$ Specified in TS 25.133 [2] section 8.4.2.3.2 as 480ms

$T_{\text{identify, inter}}$ Specified in TS 25.133 [2] section 8.4.2.3.1 as 2.72 s in this case, thus 3sec for T2 is sufficient for identification of cell 1.

Note: The calculation based on the S-CCPCH carrying the FACH provides a measurement occasion of 20ms repeated every 80ms. As the MTCH TTI length is only 40ms this has to be shortened to a gap of 10ms every 80ms, the re-selection delay is based upon.

T_{SI} : The time required for receiving all the relevant system information data according to the reception procedure and the RRC procedure delay of system information blocks defined in 25.331 [8] for a UTRAN cell. 1280 ms is assumed in this test case.

Note: Since 1280 ms is one of the typical values for repeating system information blocks, T_{SI} of 1280 ms could be increased by the RRC procedure delay in order to allow the SIB repetition period of 1280 ms.

T_{RA} : T_{RA} is a delay is caused by the physical random access procedure described in TS 25.214 [5] section 6.1. A persistence value is assumed to be 1 in this test case and therefore T_{RA} in this test case is 40 ms.

Note: The maximum allowed time to be used to perform the measurements for a UE in an MBMS session may be smaller than the duration of the measurement occasion to fulfill the MBMS demodulation performance.

This gives a total of 1.83 s, allow 1.9s in the test case.

The reference for this requirement is TS 25.133 [2] clause A.5.5.4.1.

8.3.5.4.3 Test purpose

The purpose of this test is to verify the requirement for the cell identification for UEs in an MBMS PTM session and the required functionality on measurement occasions by use of a cell re-selection test case.

8.3.5.4.4 Method of test

8.3.5.4.4.1 Initial conditions

Test environment: normal; see clauses G.2.1 and G.2.2.

Frequencies to be tested: mid range; see clause G.2.4.

For the test parameters given in tables 8.3.5.4.4.1, 8.3.5.4.4.2, 8.3.5.4.4.3, 8.3.5.4.4.4, 8.3.5.4.4.5 and 8.3.5.4.4.6. The UE is requested to receive the MBMS service and monitor neighbouring cells on 2 carriers. The maximum repetition period of the relevant system info blocks that needs to be received by the UE to camp on a cell shall be 1280 ms.

Table 8.3.5.4.4.1: General test parameters for Cell Re-selection in CELL_FACH

Parameter		Unit	Value	Comment
initial condition	Active cell		Cell2	
final condition	Active cell		Cell1	
Access Service Class (ASC#0) - Persistence value		-	1	Selected so that no additional delay is caused by the random access procedure. The value shall be used for all cells in the test.
HCS				Not used
MBMS preferred frequency layer				Not used
T1		s	15(initial), 5 (repetition)	
T2		s	3	
T3		s	3	

The transport and physical parameters of the S-CCPCH carrying the FACH are defined in Table 8.3.5.4.2.2 and Table 8.3.5.4.2.3.

Table 8.3.5.4.4.2: Physical channel parameters for S-CCPCH_1 carrying the FACH.

Parameter	Unit	Level
Channel bit rate	Kbps	60
Channel symbol rate	Ksps	30
Slot Format #l	-	4
TFCI	-	OFF
Power offsets of TFCI and Pilot fields relative to data field	dB	0

Table 8.3.5.4.4.3: Transport channel parameters for S-CCPCH_1

Parameter	FACH
Transport Channel Number	1
Transport Block Size	480
Transport Block Set Size	480
Transmission Time Interval	20 ms
Type of Error Protection	Convolution Coding
Coding Rate	1/2
Rate Matching attribute	256
Size of CRC	16
Position of TrCH in radio frame	Fixed

The transport and physical parameters of the S-CCPCH carrying the MTCH are defined in Table 8.3.5.4.2.4 and Table 8.3.5.4.2.5.

Table 8.3.5.4.4.4: Physical channel parameters for S-CCPCH_2 carrying the MTCH.

Parameter	Unit	Level
Channel bit rate	Kbps	960
Channel symbol rate	Ksps	480
Slot Format #l	-	14
TFCI	-	ON
Power offsets of TFCI and Pilot fields relative to data field	dB	0

Table 8.3.5.4.4.5: Transport channel parameters for S-CCPCH_2

Parameter	FACH
Transport Channel Number	1
Transport Block Size	2560
Transport Block Set Size	10240
Transmission Time Interval	40ms
Type of Error Protection	Turbo Coding
Coding Rate	1/3
Rate Matching attribute	256
Size of CRC	16
Position of TrCH in radio frame	Flexible

Table 8.3.5.4.4.6: Cell specific test parameters for Cell re-selection in CELL_FACH state

Parameter	Unit	Cell 1			Cell 2		
		T1	T2	T3	T1	T2	T3
UTRA RF Channel Number		Channel 1			Channel 2		
CPICH_Ec/I _{or}	dB	-10			-10		
PCCPCH_Ec/I _{or}	dB	-12			-12		
SCH_Ec/I _{or}	dB	-12			-12		
PICH_Ec/I _{or}	dB	-15			-15		
S-CCPCH_1_Ec/I _{or}	dB	-12			-12		
S-CCPCH_2_Ec/I _{or}	dB	n.a.			-6		
OCNS_Ec/I _{or}	dB	Note 1			Note 1		
\hat{I}_{or}/I_{oc}	dB	-infinity	-3.37	0	0	0	-5
I_{oc}	dBm/3.84 MHz	-70					
CPICH_Ec/I _o	dB	-infinity	-15	-13	-13	-13	-16.2
Propagation Condition		AWGN					
Cell_selection_and_reselection_quality_measure		CPICH E _c /N ₀			CPICH E _c /N ₀		
Qqualmin	dB	-20			-20		
Qrxlevmin	dBm	-115			-115		
UE_TXPWR_MAX_RACH	dBm	21			21		
Qoffset2 _{s,n}	dB	C1, C2: 0			C2, C1: 0		
Qhyst2	dB	0			0		
Treselection	S	0			0		
Sintrasearch	dB	not sent			not sent		
Sintersearch	dB	not sent			not sent		
IE "FACH Measurement occasion info"		Sent			Sent		
FACH Measurement occasion cycle length coefficient		2			2		
Inter-frequency FDD measurement indicator		TRUE			TRUE		
Inter-frequency TDD measurement indicator		FALSE			FALSE		
Note 1. The power of the OCNS channel that is added shall make the total power from the cell to be equal to I _{or} .							

The cell re-reselection delay is defined as the time from the beginning of time period T3, to the moment when the UE camps on Cell 1, and starts to send preambles on the PRACH for sending the CELL UPDATE message with cause value "cell reselection" in Cell 1.

8.3.5.4.4.2 Procedure

TBD

Specific Message Contents

All messages indicated above shall use the same content as described in the default message content in clause 9 of 34.108 [3].

8.3.5.4.5 Test requirements

The cell re-reselection delay defined as the time from the beginning of time period T3, to the moment when the UE camps on Cell 1, and starts to send preambles on the PRACH for sending the CELL UPDATE message with cause value "cell reselection" in Cell 1.

The cell re-selection delay shall be less than 1.9s.

During T1 and T2 the MTCH SDU ER shall not exceed 4.0%.

8.3.6 Cell Re-selection in CELL_PCH

8.3.6.1 One frequency present in the neighbour list

8.3.6.1.1 Definition and applicability

The cell re-selection delay is defined as the time from a change of cell levels to the moment when this change makes the UE camp on a new cell, and starts to send preambles on the PRACH for the CELL UPDATE message with cause value "cell reselection" in the new cell.

The requirements and this test apply to the FDD UE.

8.3.6.1.2 Minimum requirements

The cell re-selection delay shall be less than 8 s with a DRX cycle length of 1.28 s.

The rate of correct cell reselections observed during repeated tests shall be at least 90% with a confidence level of 95 %.

NOTE: The cell re-selection delay can be expressed as: $T_{\text{evaluateFDD}} + T_{\text{SI}}$, where:

$T_{\text{evaluateFDD}}$	See table 4.1 in TS 25.133 [2] clause 4.2.2.
T_{SI}	Maximum repetition period of relevant system info blocks that needs to be received by the UE to camp on a cell. 1280 ms is assumed in this test case.

This gives a total of 7.68 s, allow 8s in the test case.

The normative reference for this requirement is TS 25.133 [2] clauses 5.6.2 and A.5.6.1.

8.3.6.1.3 Test purpose

To verify that the UE meets the minimum requirements and is capable of camping on to a new cell, within the required time, when the preferred cell conditions change.

8.3.6.1.4 Method of test

8.3.6.1.4.1 Initial conditions

Test environment: normal; see clauses G.2.1 and G.2.2.

Frequencies to be tested: mid range; see clause G.2.4.

This scenario implies the presence of 1 carrier and 6 cells as given in tables 8.3.6.1.1 to 8.3.6.1.3. The UE is requested to monitor neighbouring cells on 1 carrier. The maximum repetition period of the relevant system info blocks that needs to be received by the UE to camp on a cell shall be 1280 ms.

Table 8.3.6.1.1: General test parameters for Cell Re-selection in CELL_PCH, one freq. in neighbour list

Parameter		Unit	Value	Comment
initial condition	Active cell		Cell2	
	Neighbour cells		Cell1, Cell3, Cell4, Cell5, Cell6	
final condition	Active cell		Cell1	
Access Service Class (ASC#0) - Persistence value		-	1	Selected so that no additional delay is caused by the random access procedure. The value shall be used for all cells in the test.
HCS				Not used
T _{SI}		ms	1280	See Annex I for the SIB repetition period of system information blocks.
DRX cycle length		s	1.28	The value shall be used for all cells in the test.
T1		s	15	T1 need to be defined so that cell re-selection reaction time is taken into account.
T2		s	15	T2 need to be defined so that cell re-selection reaction time is taken into account.

Table 8.3.6.1.2: Cell specific test parameters for Cell re-selection in CELL_PCH state, one freq. in neighbour list

Parameter	Unit	Cell 1		Cell 2		Cell 3		Cell 4		Cell 5		Cell 6	
		T1	T2	T1	T2	T1	T2	T1	T2	T1	T2	T1	T2
UTRA RF Channel Number		Channel 1		Channel 1		Channel 1		Channel 1		Channel 1		Channel 1	
CPICH_Ec/Ior	dB	-10		-10		-10		-10		-10		-10	
PCCPCH_Ec/Ior	dB	-12		-12		-12		-12		-12		-12	
SCH_Ec/Ior	dB	-12		-12		-12		-12		-12		-12	
PICH_Ec/Ior	dB	-15		-15		-15		-15		-15		-15	
OCNS_Ec/Ior	dB	-0.941		-0.941		-0.941		-0.941		-0.941		-0.941	
\hat{I}_{or}/I_{oc}	dB	7.3	10.27	10.27	7.3	0.27	0.27	0.27	0.27	-4.8	-7.4	-4.8	-7.4
$\hat{I}_{or(Notes\ 1)}$	dBm	-62.73	-59.73	-59.73	-62.73	-69.73	-69.73	-69.73	-69.73	-74.75	-77.39	-74.75	-77.39
I_{oc}	dBm / 3.84 MHz	-70											
CPICH_Ec/Io	dB	-16	-13	-13	-16	-23		-23		-23		-23	
Propagation Condition		AWGN											
Cell_selection_and_reselection_quality_measure		CPICH E _c /N ₀		CPICH E _c /N ₀		CPICH E _c /N ₀		CPICH E _c /N ₀		CPICH E _c /N ₀		CPICH E _c /N ₀	
Qqualmin	dB	-20		-20		-20		-20		-20		-20	
Qrxlevmin	dBm	-115		-115		-115		-115		-115		-115	
UE_TXPWR_MAX_RACH	dBm	21		21		21		21		21		21	
Qoffset2 _{s, n}	dB	C1, C2: 0 C1, C3: 0 C1, C4: 0 C1, C5: 0 C1, C6: 0		C2, C1: 0 C2, C3: 0 C2, C4: 0 C2, C5: 0 C2, C6: 0		C3, C1: 0 C3, C2: 0 C3, C4: 0 C3, C5: 0 C3, C6: 0		C4, C1: 0 C4, C2: 0 C4, C3: 0 C4, C5: 0 C4, C6: 0		C5, C1: 0 C5, C2: 0 C5, C3: 0 C5, C4: 0 C5, C6: 0		C6, C1: 0 C6, C2: 0 C6, C3: 0 C6, C4: 0 C6, C5: 0	
Qhyst2	dB	0		0		0		0		0		0	
Treselection	s	0		0		0		0		0		0	
Sintrasearch	dB	not sent		not sent		not sent		not sent		not sent		not sent	

Note 1 The nominal \hat{I}_{or} values, although not explicitly defined in 25.133 [2] are added here since they are implied and need to be identified so that the test equipment can be configured.

8.3.6.1.4.2 Procedure

- 1) The SS activates cell 1-6 with T1 defined parameters in table 8.3.6.1.3 and monitors cell 1 and 2 for random access requests from the UE.
- 2) The UE is switched on.
- 3) An RRC connection is set up according to the generic set-up procedure specified in TS 34.108 [3] subclause 7.3.3 to place the UE in the CELL_PCH state on Cell 2 and then the SS waits for this process to complete.
- 4) After 15 s from the completion of step 3 or the beginning of T1, the parameters are changed to those defined for T2 in table 8.3.6.1.3.
- 5) If the UE responds on Cell 1 with a PRACH (CELL UPDATE message cause "cell reselection") within 8s, then a success is recorded, the SS shall transmit a CELL UPDATE CONFIRM message and then the procedure moves to step 7.
- 6) Since the UE has failed to respond with the correct message within the allowed time, a failure is recorded. The SS shall then wait for a total of 15s from the beginning of T2 and if no response is received, the UE shall be switched off and the procedure returns to step 1. Otherwise the SS shall transmit a CELL UPDATE CONFIRM message and then the procedure continues with step 7.
- 7) After a total of 15 s from the beginning of T2, the parameters are changed to those defined for T1 in table 8.3.6.1.3.
- 8) If the UE responds on Cell 2 with a PRACH (CELL UPDATE message cause "cell reselection") within 8s, then a success is recorded and the procedure moves to step 10.
- 9) Since the UE has failed to respond with the correct message within the allowed time, a failure is recorded. The SS shall then wait for a total of 15s from the beginning of T1 and if no response is received the UE shall be switched off and the procedure returns to step 1. Otherwise the SS shall transmit a CELL UPDATE CONFIRM message and then the procedure continues with step 10.
- 10) Steps 4 to 10 are repeated until the confidence level according to annex F.6.2 is achieved.

NOTE 1: The time required for receiving all the relevant system information data according to the reception procedure and the RRC procedure delay of system information blocks defined in 25.331 for a UTRAN cell. Since the maximum time to read the relevant system info blocks that needs to be received by the UE to camp on a cell is 1420ms (see note 2) and the maximum RRC procedure delay for reception system information block is 100ms, 1520 ms is assumed in this test case. Therefore this gives a total of 7.92s (Minimum requirement + 240ms), allow 8s in the test case.

NOTE 2: The maximum repetition period of the relevant system info blocks that needs to be received by the UE to camp on a cell is 1280ms. The Master Information Block (MIB) is repeated every 8 frame and SIB5 (and SIB11) is segmented into 4 segments where the first segment is scheduled adjacent to the MIB at SIB_POS=40 and the other three segments are scheduled after the MIB (SIB_POS=42, 44 and 46). The maximum time for a UE to read SIB5 will occur if the UE start reading the BCH at the SFN after the MIB located prior to the first segment of SIB5 (SIB_POS 32). Then the UE will not be able to read SIB5 until the second occurrence of SIB5, which will happen at SIB_POS 46 + 1280ms. This gives that the maximum time for the UE to read the relevant system info will be 1420ms ((SIB_POS 46 – SIB_POS 32)*10ms +1280ms).

Specific Message Contents

All messages indicated above shall use the same content as described in the default message content in clause 9 of 34.108 [3], with the following exceptions:

PHYSICAL CHANNEL RECONFIGURATION (Step 3)

Information Element	Value/remark
RRC State Indicator	CELL_PCH
UTRAN DRX cycle length coefficient	7
Downlink information for each radio link - Primary CPICH info - Primary scrambling code	Reference to TS 34.108 [3] clause 6.1 "Default settings (FDD)"

Contents of CELL UPDATE CONFIRM message for CELL_PCH

Information Element	Value/remark
RRC transaction identifier	0
Activation time	Not Present
RRC State indicator	CELL_PCH
UTRAN DRX cycle length coefficient	7

8.3.6.1.5 Test requirements

For the test to pass, the total number of successful attempts shall be more than 90% of the cases with a confidence level of 95 %.

Table 8.3.6.1.3: Cell specific test requirements for Cell re-selection in CELL_PCH state, one freq. in neighbour list

Parameter	Unit	Cell 1		Cell 2		Cell 3		Cell 4		Cell 5		Cell 6	
		T1	T2	T1	T2	T1	T2	T1	T2	T1	T2	T1	T2
UTRA RF Channel Number		Channel 1		Channel 1		Channel 1		Channel 1		Channel 1		Channel 1	
CPICH_Ec/I _{or}	dB	-9.4		-9.4		-10.5		-10.5		-10.5		-10.5	
PCCPCH_Ec/I _{or}	dB	-11.4		-11.4		-12.5		-12.5		-12.5		-12.5	
SCH_Ec/I _{or}	dB	-11.4		-11.4		-12.5		-12.5		-12.5		-12.5	
PICH_Ec/I _{or}	dB	-14.4		-14.4		-15.5		-15.5		-15.5		-15.5	
OCNS_Ec/I _{or}	dB	-1.10		-1.10		-0.83		-0.83		-0.83		-0.83	
\hat{I}_{or}/I_{oc} Note 1	dB	7.00	10.40	10.40	7.00	0.30		0.30		0.30		0.30	
\hat{I}_{or}	dBm	-63.0	-59.6	-59.6	-63.0	-69.7		-69.7		-69.7		-69.7	
I_{oc}	dBm / 3,84 MHz	-70											
CPICH_Ec/I _o Note 1	dB	-15.7	-12.3	-12.3	-15.7	-23.5		-23.5		-23.5		-23.5	

All other parameters and conditions specified in table 8.3.6.1.2 are unchanged.

NOTE 1: These parameters are not directly settable, but are derived by calculation from the settable parameters.

NOTE 2: If the above Test Requirement differs from the Minimum Requirement then the Test Tolerance applied for this test is non-zero. The Test Tolerance for this test is defined in clause F.2 and the explanation of how the Minimum Requirement has been relaxed by the Test Tolerance is given in clause F.4.

8.3.6.2 Two frequencies present in the neighbour list

8.3.6.2.1 Definition and applicability

The cell re-selection delay is defined as the time from a change of cell levels to the moment when this change makes the UE camp on a new cell, and starts to send preambles on the PRACH for the CELL UPDATE message with cause value "cell reselection" in the new cell.

The requirements and this test apply to the FDD UE.

8.3.6.2.2 Minimum requirement

The cell re-selection delay shall be less than 8 s with a DRX cycle length of 1.28 s.

The rate of correct cell reselections observed during repeated tests shall be at least 90% with a confidence level of 95 %.

NOTE: The cell re-selection delay can be expressed as: $T_{\text{evaluateFDD}} + T_{\text{SI}}$, where:

$T_{\text{evaluateFDD}}$	See table 4.1 in TS 25.133 [2] clause 4.2.2.
T_{SI}	Maximum repetition period of relevant system info blocks that needs to be received by the UE to camp on a cell. 1280 ms is assumed in this test case.

This gives a total of 7.68 s, allow 8s in the test case.

The normative reference for this requirement is TS 25.133 [2] clauses 5.6.2 and A.5.6.2.

8.3.6.2.3 Test purpose

To verify that the UE meets the minimum requirement and is capable of camping on to a new cell, within the required time, when the preferred cell conditions change.

8.3.6.2.4 Method of test

8.3.6.2.4.1 Initial conditions

Test environment: normal; see clauses G.2.1 and G.2.2.

Frequencies to be tested: mid range; see clause G.2.4.

This scenario implies the presence of 2 carriers and 6 cells as given in tables 8.3.6.2.1 to 8.3.6.2.3. The UE is requested to monitor neighbouring cells on 2 carriers. The maximum repetition period of the relevant system info blocks that needs to be received by the UE to camp on a cell shall be 1 280 ms.

Table 8.3.6.2.1: General test parameters for Cell Re-selection in CELL_PCH, two freqs. in neighbour list

Parameter		Unit	Value	Comment
initial condition	Active cell		Cell2	
	Neighbour cells		Cell1, Cell3, Cell4, Cell5, Cell6	
final condition	Active cell		Cell1	
Access Service Class (ASC#0) - Persistence value		-	1	Selected so that no additional delay is caused by the random access procedure. The value shall be used for all cells in the test.
HCS				Not used
T_{SI}		ms	1280	See Annex I for the SIB repetition period of system information blocks.
DRX cycle length		s	1.28	The value shall be used for all cells in the test.
T1		s	30	T1 need to be defined so that cell re-selection reaction time is taken into account.
T2		s	15	T2 need to be defined so that cell re-selection reaction time is taken into account.

NOTE: Monitored cell list size has 6 cells on 2 carriers. See Annex I for the cell information.

Table 8.3.6.2.2: Cell specific test parameters for Cell re-selection in CELL_PCH state, two freqs. in neighbour list

Parameter	Unit	Cell 1		Cell 2		Cell 3		Cell 4		Cell 5		Cell 6	
		T1	T2	T1	T2	T1	T2	T1	T2	T1	T2	T1	T2
UTRA RF Channel Number		Channel 1		Channel 2		Channel 1		Channel 1		Channel 2		Channel 2	
CPICH_Ec/Ior	dB	-10		-10		-10		-10		-10		-10	
PCCPCH_Ec/Ior	dB	-12		-12		-12		-12		-12		-12	
SCH_Ec/Ior	dB	-12		-12		-12		-12		-12		-12	
PICH_Ec/Ior	dB	-15		-15		-15		-15		-15		-15	
OCNS_Ec/Ior	dB	-0.941		-0.941		-0.941		-0.941		-0.941		-0.941	
\hat{I}_{or}/I_{oc}	dB	-3.4	2.2	2.2	-3.4	-7.4	-4.8	-7.4	-4.8	-4.8	-7.4	-4.8	-7.4
$\hat{I}_{or(1)}$	dBm	-73.39	-67.75	-67.75	-73.39	-77.39	-74.75	-77.39	-74.75	-74.75	-77.39	-74.75	-77.39
I_{oc}	dBm/3.84 MHz	-70											
CPICH_Ec/Io	dB	-16	-13	-13	-16	-20		-20		-20		-20	
Propagation Condition		AWGN											
Cell_selection_and_reselection_quality_measure		CPICH E _c /N ₀		CPICH E _c /N ₀		CPICH E _c /N ₀		CPICH E _c /N ₀		CPICH E _c /N ₀		CPICH E _c /N ₀	
Qqualmin	dB	-20		-20		-20		-20		-20		-20	
Qrxlevmin	dBm	-115		-115		-115		-115		-115		-115	
UE_TXPWR_MAX_RACH	dBm	21		21		21		21		21		21	
Qoffset2 _{s, n}	dB	C1, C2: 0 C1, C3: 0 C1, C4: 0 C1, C5: 0 C1, C6: 0		C2, C1: 0 C2, C3: 0 C2, C4: 0 C2, C5: 0 C2, C6: 0		C3, C1: 0 C3, C2: 0 C3, C4: 0 C3, C5: 0 C3, C6: 0		C4, C1: 0 C4, C2: 0 C4, C3: 0 C4, C5: 0 C4, C6: 0		C5, C1: 0 C5, C2: 0 C5, C3: 0 C5, C4: 0 C5, C6: 0		C6, C1: 0 C6, C2: 0 C6, C3: 0 C6, C4: 0 C6, C5: 0	
Qhyst2	dB	0		0		0		0		0		0	
Treselection	s	0		0		0		0		0		0	
Sintrasearch	dB	not sent		not sent		not sent		not sent		not sent		not sent	
Sintersearch	dB	not sent		not sent		not sent		not sent		not sent		not sent	

Note 1 The nominal \hat{I}_{or} values, although not explicitly defined in 25.133 [2] are added here since they are implied and need to be identified so that the test equipment can be configured.

8.3.6.2.4.2 Procedure

- 1) The SS activates cell 1-6 with T1 defined parameters in table 8.3.6.2.3 and monitors cell 1 and 2 for random access requests from the UE.
- 2) The UE is switched on.
- 3) A RRC connection is set up according the generic set-up procedure specified in TS 34.108 [3] subclause 7.3.3 to place the UE in CELL_PCH state on cell 2. The SS waits for this process to complete.
- 4) After 30 s from the completion of step 3 or the beginning of T1, the parameters are changed to those defined for T2 in table 8.3.6.2.3.
- 5) If the UE responds on Cell 1 with a PRACH (CELL UPDATE message cause "cell reselection") within 8s, then a success is recorded, the SS shall transmit a CELL UPDATE CONFIRM message and then the procedure moves to step 7.
- 6) Since the UE has failed to respond with the correct message within the allowed time, a failure is recorded. The SS shall then wait for a total of 15s from the beginning of T2 and if no response is received the UE shall be switched off and the procedure returns to step 1. Otherwise the SS shall transmit a CELL UPDATE CONFIRM message and then the procedure continues with step 7.
- 7) After a total of 15 s from the beginning of T2, the parameters are changed to those defined for T1 in table 8.3.6.2.3.
- 8) If the UE responds on Cell 2 with a PRACH (CELL UPDATE message cause "cell reselection") within 8s, then a success is recorded and the procedure moves to step 10.
- 9) Since the UE has failed to respond with the correct message within the allowed time, a failure is recorded. The SS shall then wait for a total of 15s from the beginning of T1 and if no response is received the UE shall be switched off and the procedure returns to step 1. Otherwise the SS shall transmit a CELL UPDATE CONFIRM message and then the procedure continues with step 10.
- 10) After a total of 15 s from the beginning of T1, the parameters are changed to those defined for T2 in table 8.3.6.2.3.
- 11) Steps 5 to 10 are repeated until the confidence level according to annex F.6.2 is achieved.

NOTE 1: T1 is initially 30 s to allow enough time for the UE to search for cells as it has no prior knowledge of these.

NOTE 2: The time required for receiving all the relevant system information data according to the reception procedure and the RRC procedure delay of system information blocks defined in 25.331 for a UTRAN cell. Since the maximum repetition period of the relevant system info blocks that needs to be received by the UE to camp on a cell is 1420ms (see note 3) and the maximum RRC procedure delay for reception system information block is 100ms, 1520 ms is assumed in this test case. Therefore this gives a total of 7.82s (Minimum requirement + 240ms), allow 8s in the test case.

NOTE 3: The maximum repetition period of the relevant system info blocks that needs to be received by the UE to camp on a cell is 1280ms. The Master Information Block (MIB) is repeated every 8 frame and SIB5 (and SIB11) is segmented into 4 segments where the first segment is scheduled adjacent to the MIB at SIB_POS=40 and the other three segments are scheduled after the MIB (SIB_POS=42, 44 and 46). The maximum time for a UE to read SIB5 will occur if the UE start reading the BCH at the SFN after the MIB located prior to the first segment of SIB5 (SIB_POS 32). Then the UE will not be able to read SIB5 until the second occurrence of SIB5, which will happen at SIB_POS 46 + 1280ms. This gives that the maximum time for the UE to read the relevant system info will be 1420ms ((SIB_POS 46 – SIB_POS 32)*10ms + 1280ms).

Specific Message Contents

All messages indicated above shall use the same content as described in the default message content in clause 9 of 34.108 [3], with the following exceptions:

PHYSICAL CHANNEL RECONFIGURATION (Step 3)

Information Element	Value/remark
RRC State Indicator	CELL_PCH
UTRAN DRX cycle length coefficient	7
Downlink information for each radio link - Primary CPICH info - Primary scrambling code	Reference to TS 34.108 [3] clause 6.1 "Default settings (FDD)"

Contents of CELL UPDATE CONFIRM message for CELL_PCH

Information Element	Value/remark
RRC transaction identifier	0
Activation time	Not Present
RRC State indicator	CELL_PCH
UTRAN DRX cycle length coefficient	7

8.3.6.2.5 Test requirements

For the test to pass, the total number of successful tests shall be more than 90% of the cases with a confidence level of 95 %.

Table 8.3.6.2.3: Cell specific test requirements for Cell re-selection in CELL_PCH state, two freqs. in neighbour list

Parameter	Unit	Cell 1		Cell 2		Cell 3		Cell 4		Cell 5		Cell 6	
		T1	T2	T1	T2	T1	T2	T1	T2	T1	T2	T1	T2
UTRA RF Channel Number		Channel 1		Channel 2		Channel 1		Channel 1		Channel 2		Channel 2	
CPICH_Ec/I _{or}	dB	-9.3		-9.3		-10.8		-10.8		-10.8		-10.8	
PCCPCH_Ec/I _{or}	dB	-11.3		-11.3		-12.8		-12.8		-12.8		-12.8	
SCH_Ec/I _{or}	dB	-11.3		-11.3		-12.8		-12.8		-12.8		-12.8	
PICH_Ec/I _{or}	dB	-14.3		-14.3		-15.8		-15.8		-15.8		-15.8	
OCNS_Ec/I _{or}	dB	-1.13		-1.13		-0.77		-0.77		-0.77		-0.77	
\hat{I}_{or}/I_{oc} Note 1	dB	-3.40	+4.80	+4.80	-3.40	-7.40	-3.00	-7.40	-3.00	-3.00	-7.40	-3.00	-7.40
\hat{I}_{or}	dBm	-73.4	-67.0	-67.0	-73.4	-77.4	-74.8	-77.4	-74.8	-74.8	-77.4	-74.8	-77.4
I_{oc}	dBm/3.84 MHz	-70.0	-71.8	-71.8	-70.0	-70.0	-71.8	-70.0	-71.8	-71.8	-70.0	-71.8	-70.0
CPICH_Ec/I _o Note 1	dB	-15.3	-11.5	-11.5	-15.3	-20.8	-20.8	-20.8	-20.8	-20.8	-20.8	-20.8	-20.8

All other parameters and conditions specified in table 8.3.6.2.2 are unchanged.

NOTE 1: These parameters are not directly settable, but are derived by calculation from the settable parameters.

NOTE 2: If the above Test Requirement differs from the Minimum Requirement then the Test Tolerance applied for this test is non-zero. The Test Tolerance for this test is defined in clause F.2 and the explanation of how the Minimum Requirement has been relaxed by the Test Tolerance is given in clause F.4.

8.3.6.3 Cell re-selection during an MBMS session, one UTRAN inter-frequency and 2 GSM cells present in the neighbour list

8.3.6.3.1 Definition and applicability

The cell re-selection delay is defined as the time from a change of cell levels to the moment when this change makes the UE camp on a new cell, and starts to send preambles on the PRACH for the CELL UPDATE message with cause value "cell reselection" in the new cell.

The requirements and this test apply to a Release 6 UE supporting GSM and MBMS.

Editor's note: This test is incomplete

8.3.6.3.2 Minimum requirement

The cell re-selection delay is defined as the time from the beginning of time period T3, to the moment when the UE camps on Cell 3, and starts to send the RR Channel Request message for location update to Cell 3.

The cell re-selection delay shall be less than $2.75 \text{ s} + T_{\text{BCCH}}$, where T_{BCCH} is the maximum time allowed to read BCCH data from GSM cell, see TS 45.008 [30].

During T1 and T2 the MTCH SDU ER shall not exceed 4.0%.

The rate of correct cell reselections observed during repeated tests shall be at least 90%.

NOTE: The cell re-selection delay can be expressed as: $\text{Max}(3 * T_{\text{measureFDD}}, T_{\text{measureGSM}} + \text{DRX cycle length}) + T_{\text{BCCH}}$, where:

$T_{\text{measureFDD}}$ See table 4.1 in TS 25.133 [2] clause 4.2.2.

$T_{\text{measureGSM}}$ See table 4.1 in TS 25.133 [2] clause 4.2.2.

DRX cycle length 160ms see Table A.4.7.A

T_{BCCH} Maximum time allowed to read BCCH data from GSM cell, see TS 45.008 [30]. According to [20] and [30], the maximum time allowed to read the BCCH data, when being synchronized to a BCCH carrier, is 1.9 s.

This gives a total of $2.72 \text{ s} + T_{\text{BCCH}}$, allow $2.75 \text{ s} + T_{\text{BCCH}}$ in the test case.

The normative reference for this requirement is TS 25.133 [2] clauses 4.2.2 and A.5.6.3.

8.3.6.3.3 Test purpose

To verify that the UE meets the minimum requirement and is capable of camping on to a new cell, within the required time, when the preferred cell conditions change.

8.3.6.3.4 Method of test

8.3.6.3.4.1 Initial conditions

Test environment: normal; see clauses G.2.1 and G.2.2.

Frequencies to be tested: mid range; see clause G.2.4.

This scenario implies the presence of 1 UTRAN serving cell, 1 UTRAN inter-frequency cell and 2 GSM cells of which one is to be re-selected. The UE is requested to monitor neighbor cells on 2 UMTS carriers (Channel 1, Channel 2) and 12 GSM cells. Test parameters are given in Tables 8.3.6.3.1 to 8.3.6.3.5.

Table 8.3.6.3.1: General test parameters for Cell Re-selection

Parameter		Unit	Value	Comment
Initial condition	Active cell		Cell2	UMTS cell providing the MBMS session
	Neighbour cells		Cell1	UMTS inter-frequency neighbour cell
			Cell3, Cell4	GSM cells
Final condition	Active cell		Cell3	
DRX cycle length		ms	160	
HCS				Not used
MBMS preferred frequency layer				Not used
Monitored cell list size			2 UMTS cells and 12 GSM cells, including the UARFCN of UMTS cells 1, 2 and the ARFCN of the GSM cells 3,4	NOTE: See Annex I for cell information
T1		s	15 (initial), 5 repeated	
T2		s	45	
T3		s	7	

The transport and physical channel parameters of the S-CCPCH_2 carrying the MTCH are defined in Tables 8.3.6.3.2 and 8.3.6.3.3.

The transport and physical channel parameters of S-CCPCH_1 carrying the FACH and PCH are TBD.

The transport and physical channel parameters of the S-CCPCH carrying the MCCH are TBD.

Table 8.3.6.3.2: Physical channel parameters for S-CCPCH_2 carrying the MTCH.

Parameter	Unit	Level
Channel bit rate	kbps	960
Channel symbol rate	ksps	480
Slot Format #1	-	14
TFCI	-	ON
Power offsets of TFCI and Pilot fields relative to data field	dB	0

Table 8.3.6.3.3: Transport channel parameters for S-CCPCH_2

Parameter	FACH
Transport Channel Number	1
Transport Block Size	2560
Transport Block Set Size	10240
Transmission Time Interval	40ms
Type of Error Protection	Turbo Coding
Coding Rate	1/3
Rate Matching attribute	256
Size of CRC	16
Position of TrCH in radio frame	Flexible

Table 8.3.6.3.4: Cell specific test parameters for serving Cell2 and inter-frequency neighbour Cell1

Parameter	Unit	Cell 1			Cell 2		
		T1	T2	T3	T1	T2	T3
UTRA RF Channel Number		Channel 1			Channel 2		
CPICH_Ec/Ior	dB	-10			-10		
PCCPCH_Ec/Ior	dB	-12			-12		
SCH_Ec/Ior	dB	-12			-12		
PICH_Ec/Ior	dB	-15			-15		
S-CCPCH_1_Ec/Ior	dB	-12			-12		
S-CCPCH_2_Ec/Ior	dB	n.a.			[-6,8]		
OCNS_Ec/Ior	dB	Note 1			Note 1		
\hat{I}_{or}/I_{oc}	dB	-infinity	-4.75	-infinity	0	0	-15
I_{oc}	dBm/3.8 4 MHz	-70					
CPICH_Ec/Io	dB	-infinity	-16	-infinity	-13	-13	-25.14
CPICH_RSCP		-infinity	-84,75	-infinity	-80	-80	-95
Propagation Condition		AWGN					
Cell_selection_and_reselection_quality_measure		CPICH E _c /N ₀			CPICH E _c /N ₀		
Qqualmin	dB	-20			-20		
Qrxlevmin	dBm	-115			-115		
UE_TXPWR_MAX_RACH	dBm	21			21		
Qoffset2 _{s,n}	dB	C1, C2: 0			C2, C1: 0		
Qhyst2	dB	0			0		
Qoffset1 _{s,n}	dB				C2, C3: 0; C2, C4: 0		
Qhyst1	dB	0			0		
Treselection	s	0			0		
Sintrasearch	dB	not sent			not sent		
Sintersearch	dB	not sent			not sent		
Note 1. The power of the OCNS channel that is added shall make the total power from the cell to be equal to Ior.							

Table 8.3.6.3.5: Cell re-selection parameters for GSM cells case (cell 3 and cell4)

Parameter	Unit	Cell 3 (GSM)			Cell 4 (GSM)		
		T1	T2	T3	T1	T2	T3
Absolute RF Channel Number		ARFCN 2			ARFCN 1		
RXLEV	dBm	-infinity	-85	-85	-infinity	-85	-infinity
RXLEV_ACCESS_MIN	dBm	-104			-104		
MS_TXPWR_MAX_CCH	dBm	33			33		
FDD_Qmin	dB	-14			-14		
Qsearch_I	-	always			always		

Specific 2 quarter Message Contents

All messages indicated shall use the same content as described in the default message content in TS45.008 [30] clause 9, with the above exceptions.

8.3.6.3.4.2 Procedure

Initiation

- 1) The SS activates cell 1 to 4 with T1 defined parameters in tables 8.3.6.3.4 and 8.3.6.3.5 and monitors cell 2 and 3 for random access requests from the UE. The SS broadcast the cell reselection parameters according to tables 8.3.6.3.4 and 8.3.6.3.5.
- 2) The UE is switched on. The UE has selected the broadcast service provided by the SS (included in the MBMS_ACTIVATED_SERVICES VARIABLE).

- 3) Set up a call according to the generic call setup procedure TS34.108 [3] clause 7.3.10 to configure and activate an MBMS broadcast session, and transition to CELL_PCH state. The SS waits for this procedure to be completed.
- 4) Initiate the variables N_UEOK_T1_TEMP, N_UEOK_T2_TEMP, N_UEOK_T1_ACC, N_UEOK_T2_ACC, N_SS_T1_ACC, N_SS_T2_ACC to 0.

T1

- 5) Start T1, and simultaneously start transmitting valid MAC headers on MTCH
- 6) After 5 s (15 s in the first iteration) from the start of T1, start transmitting invalid MAC headers on MTCH and store N_SS_T1

Go to CELL_FACH and read out UE counter

Note: Steps 7 to 14 below implies that the duration of T1 is longer than specified in the core requirement. The active measurement period is however correct.

- 7) The SS transmits a PAGING TYPE 1 message to the UE on the PCH and the UE moves to CELL_FACH state, sending a CELL UPDATE message. The SS replies with a CELL UPDATE CONFIRM message.
- 8) UE confirms the received C-RNTI to be used in CELL_FACH state by transmitting a UTRAN MOBILITY INFORMATION CONFIRM message on the uplink DCCH.
- 9) The SS sends a “UE TEST LOOP MODE 3 RLC SDU COUNTER REQUEST” message.
- 10) The UE to respond by a “UE TEST LOOP MODE 3 RLC SDU COUNTER RESPONSE” message reporting the number of received RLC SDUs on MTCH. Store this in the variable N_UEOK_T1_TEMP.
- 11) The SS calculate the following:

N_SS_T1: Number of SS transmitted RLC SDUs with valid MAC headers during T1

N_UEOK: UE received RLC SDUs as reported in the “UE TEST LOOP MODE 3 RLC SDU COUNTER RESPONSE” message in step 10

N_UEOK_T1: UE received RLC SDUs during T1. This is calculated as $N_{UEOK_T1_TEMP} - N_{UEOK_T2_TEMP}$.

N_UEOK_T1_ACC: Accumulated sum of N_UEOK_T1 during T1 periods tested so far.

N_SS_T1_ACC: Accumulated sum of N_SS_T1 during T1 periods tested so far.

Go back to CELL_PCH

- 12) The SS orders the UE to move to CELL_PCH state by transmitting a PHYSICAL CHANNEL RECONFIGURATION message with the RRC state indicator set to “CELL_PCH”.
- 13) The UE send a PHYSICAL CHANNEL RECONFIGURATION COMPLETE message

T2

- 14) The parameters are changed as described for T2 in tables 8.3.6.3.4 and 8.3.6.3.5 and the SS start sending valid MAC headers on MTCH.
- 15) After 45 s from the start of T2, the parameters are changed as described for T3 in tables 8.3.6.3.4 and 8.3.6.3.5. Simultaneously, the SS shall start transmitting invalid MAC headers on MTCH.

T3

- 16) The SS waits for a location registration procedure from the UE. If the UE begins transmitting on cell 3 (GSM cell) within 4.65 s then a success is recorded for the delay requirement and the procedure continues with step 18.
- 17) Since the UE has failed to respond with the correct message within the allowed time, a failure for the delay requirement is recorded.

Go to CELL_FACH and read out UE counter

- 18) The SS transmits a PAGING TYPE 1 message to the UE on the PCH and the UE moves to CELL_FACH state, sending a CELL UPDATE message. The SS replies with a CELL UPDATE CONFIRM message.
- 19) UE confirms the received C-RNTI to be used in CELL_FACH state by transmitting a UTRAN MOBILITY INFORMATION CONFIRM message on the uplink DCCH.
- 20) The SS sends a "UE TEST LOOP MODE 3 RLC SDU COUNTER REQUEST" message.
- 21) The UE to respond by a "UE TEST LOOP MODE 3 RLC SDU COUNTER RESPONSE" message reporting the number of received RLC SDUs on MTCH. Store this in the variable N_UEOK_T2_TEMP.
- 22) The SS calculate the following:

N_SS_T2: Number of SS transmitted RLC SDUs with valid MAC headers during T2

N_UEOK: UE received RLC SDUs as reported in the "UE TEST LOOP MODE 3 RLC SDU COUNTER RESPONSE" message in step 21

N_UEOK_T2: UE received RLC SDUs during T2. This is calculated as $N_UEOK_T2_TEMP - N_UEOK_T1_TEMP$.

N_UEOK_T2_ACC: Accumulated sum of N_UEOK_T2 during T2 periods tested so far.

N_SS_T2_ACC: Accumulated sum of N_SS_T2 during T2 periods tested so far.

Go back to CELL_PCH

- 23) The SS orders the UE to move to CELL_PCH state by transmitting a PHYSICAL CHANNEL RECONFIGURATION message with the RRC state indicator set to "CELL_PCH".
- 24) The UE send a PHYSICAL CHANNEL RECONFIGURATION COMPLETE message
- 25) After 7 s from the beginning of time period T3, the parameters are changed to those defined for T1 in tables 8.3.6.3.4 and 8.3.6.3.5.

Repeat step 5) to 25) until the confidence level for the delay requirement according to annex F.6.2 are achieved. This includes the confidence level for the RLC SDU error ratio. Refer Annex F.6.1 Table F.6.1.8-3

Post procedure

- 27) End the call according to the generic call setup procedure TS34.108 [3] clause 7.3.10.

SDU error rate is measured during concatenated time periods T1 and T2 separately, as follows:

$$SDU_ER_T1_ACC = (N_SS_T1_ACC - N_UEOK_T1_ACC) / N_SS_T1_ACC$$

$$SDU_ER_T2_ACC = (N_SS_T2_ACC - N_UEOK_T2_ACC) / N_SS_T2_ACC$$

Specific Message Contents

All messages indicated above shall use the same content as described in the default message content in clause 9 of 34.108 [3], with the exceptions stated in clause 7.3.10 of 34.108 [3]

8.3.6.3.5 Test requirements

For the test to pass, the following need to be fulfilled:

- the SDU error rate during T1 (SDU_ER_T1_ACC) shall not exceed 4.0 %,
- the SDU error rate during T2 (SDU_ER_T2_ACC) shall not exceed 4.0 %,
- the total number of successful tests of the cell re-selection delay requirement shall be more than 90% of the cases with a confidence level of 95 %.

Test tolerances are TBD.

8.3.7 Cell Re-selection in URA_PCH

8.3.7.1 One frequency present in the neighbour list

8.3.7.1.1 Definition and applicability

The cell re-selection delay is defined as the time from a change of cell levels to the moment when this change makes the UE camp on a new cell, and starts to send preambles on the PRACH for the URA UPDATE message with cause value "URA reselection" in the new cell.

The requirements and this test apply to the FDD UE.

8.3.7.1.2 Minimum requirement

The cell re-selection delay shall be less than 8 s with a DRX cycle length of 1.28 s.

The rate of correct cell reselections observed during repeated tests shall be at least 90% with a confidence level of 95 %.

NOTE: The cell re-selection delay can be expressed as: $T_{\text{evaluateFDD}} + T_{\text{SI}}$, where:

$T_{\text{evaluateFDD}}$	See table 4.1 in TS 25.133 [2] clause 4.2.2.
T_{SI}	Maximum repetition period of relevant system info blocks that needs to be received by the UE to camp on a cell. 1280 ms is assumed in this test case.

This gives a total of 7.68 s, allow 8s in the test case.

The normative reference for this requirement is TS 25.133 [2] clauses 5.7.2 and A.5.7.1.

8.3.7.1.3 Test purpose

To verify that the UE meets the minimum requirement and is capable of camping on to a new cell, within the required time, when the preferred cell conditions change.

8.3.7.1.4 Method of test

8.3.7.1.4.1 Initial conditions

Test environment: normal; see clauses G.2.1 and G.2.2.

Frequencies to be tested: mid range; see clause G.2.4.

This scenario implies the presence of 1 carrier and 6 cells as given in tables 8.3.7.1.1 to 8.3.7.1.3. The UE is requested to monitor neighbouring cells on 1 carrier. The maximum repetition period of the relevant system info blocks that needs to be received by the UE to camp on a cell shall be 1 280 ms. In System Information Block Type 2 cell1 and cell 2 URA identity is set to a different value.

Table 8.3.7.1.1: General test parameters for Cell Re-selection in URA_PCH, one freq. in neighbour list

Parameter		Unit	Value	Comment
Initial condition	Active cell		Cell2	
	Neighbour cells		Cell1, Cell3, Cell4, Cell5, Cell6	
Final condition	Active cell		Cell1	
SYSTEM INFORMATION BLOCK TYPE 2 - URA identity list - URA identity		-	0000 0000 0000 0001(B) (Cell 1) 0000 0000 0000 0010(B) (Cell 2)	
Access Service Class (ASC#0) - Persistence value		-	1	Selected so that no additional delay is caused by the random access procedure. The value shall be used for all cells in the test.
HCS				Not used
T _{SI}		ms	1280	See Annex I for the SIB repetition period of system information blocks.
DRX cycle length		s	1,28	The value shall be used for all cells in the test.
T1		s	15	T1 need to be defined so that cell re-selection reaction time is taken into account.
T2		s	15	T2 need to be defined so that cell re-selection reaction time is taken into account.

Table 8.3.7.1.2: Cell specific test parameters for Cell re-selection in URA_PCH state, one freq. in neighbour list

Parameter	Unit	Cell 1		Cell 2		Cell 3		Cell 4		Cell 5		Cell 6																			
		T1	T2	T1	T2	T1	T2	T1	T2	T1	T2	T1	T2																		
UTRA RF Channel Number		Channel 1		Channel 1		Channel 1		Channel 1		Channel 1		Channel 1																			
CPICH_Ec/Ior	dB	-10		-10		-10		-10		-10		-10																			
PCCPCH_Ec/Ior	dB	-12		-12		-12		-12		-12		-12																			
SCH_Ec/Ior	dB	-12		-12		-12		-12		-12		-12																			
PICH_Ec/Ior	dB	-15		-15		-15		-15		-15		-15																			
OCNS_Ec/Ior	dB	-0,941		-0,941		-0,941		-0,941		-0,941		-0,941																			
\hat{I}_{or}/I_{oc}	dB	7,3	10,27	10,27	7,3	0,27	0,27	0,27	0,27	-4.8	-7.4	-4.8	-7.4																		
$\hat{I}_{or(Notes\ 1)}$	dBm	-62.73	-59.73	-59.73	-62.73	-69.73	-69.73	-69.73	-69.73	-74.75	-77.39	-74.75	-77.39																		
I_{oc}	dBm / 3,84 MHz	-70																													
CPICH_Ec/Io	dB	-16	-13	-13	-16	-23		-23		-23		-23																			
Propagation Condition		AWGN																													
Cell_selection_and_reselection_quality_measure		CPICH E _c /N ₀		CPICH E _c /N ₀		CPICH E _c /N ₀		CPICH E _c /N ₀		CPICH E _c /N ₀		CPICH E _c /N ₀																			
Qqualmin	dB	-20		-20		-20		-20		-20		-20																			
Qrxlevmin	dBm	-115		-115		-115		-115		-115		-115																			
UE_TXPWR_MAX_RACH	dB	21		21		21		21		21		21																			
Qoffset2 _{s, n}	dB	C1, C2: 0	C1, C3: 0	C1, C4: 0	C1, C5: 0	C1, C6: 0	C2, C1: 0	C2, C3: 0	C2, C4: 0	C2, C5: 0	C2, C6: 0	C3, C1: 0	C3, C2: 0	C3, C4: 0	C3, C5: 0	C3, C6: 0	C4, C1: 0	C4, C2: 0	C4, C3: 0	C4, C5: 0	C4, C6: 0	C5, C1: 0	C5, C2: 0	C5, C3: 0	C5, C4: 0	C5, C6: 0	C6, C1: 0	C6, C2: 0	C6, C3: 0	C6, C4: 0	C6, C5: 0
Qhyst2	dB	0		0		0		0		0		0																			
Treselection	S	0		0		0		0		0		0																			
Sintrasearch	dB	not sent		not sent		not sent		not sent		not sent		not sent																			

Note 1 The nominal \hat{I}_{or} values, although not explicitly defined in 25.133 [2] are added here since they are implied and need to be identified so that the test equipment can be configured.

8.3.7.1.4.2 Procedure

- 1) The SS activates cell 1-6 with T1 defined parameters in table 8.3.7.1.3 and monitors cell 1 and 2 for random access requests from the UE.
- 2) The UE is switched on.
- 3) An RRC connection is set up according to the generic set-up procedure specified in TS 34.108 [3] subclause 7.3.3 to place the UE in the URA_PCH state on Cell 2 and then the SS waits for this process to complete.
- 4) After 15 s from the completion of step 3 or the beginning of T1, the parameters are changed to those defined for T2 in table 8.3.7.1.3.
- 5) If the UE responds on Cell 1 with a PRACH (URA UPDATE message cause "URA reselection") within 8s, then a success is recorded, the SS shall transmit a URA UPDATE CONFIRM message and then the procedure moves to step 7.
- 6) Since the UE has failed to respond with the correct message within the allowed time, a failure is recorded. The SS shall then wait for a total of 15s from the beginning of T2 and if no response is received, the UE shall be switched off and the procedure returns to step 1. Otherwise the SS shall transmit a URA UPDATE CONFIRM message and then the procedure continues with step 7.
- 7) After a total of another 15 s from the beginning of T2, the parameters are changed to those defined for T1 in table 8.3.7.1.3.
- 8) If the UE responds on Cell 2 with a PRACH (URA UPDATE message cause "URA reselection") within 8s, then a success is recorded and the procedure moves to step 10.
- 9) Since the UE has failed to respond with the correct message within the allowed time, a failure is recorded. The SS shall then wait for a total of 15s from the beginning of T1 and if no response is received the UE shall be switched off and the procedure returns to step 1. Otherwise the SS shall transmit a URA UPDATE CONFIRM message and then the procedure continues with step 10.
- 10) Steps 4 to 10 are repeated until the confidence level according to annex F.6.2 is achieved.

NOTE 1: The time required for receiving all the relevant system information data according to the reception procedure and the RRC procedure delay of system information blocks defined in 25.331 for a UTRAN cell. Since the maximum time to read the relevant system info blocks that needs to be received by the UE to camp on a cell is 1420ms and the maximum RRC procedure delay for reception system information block is 100ms, 1520 ms is assumed in this test case. Therefore this gives a total of 7.92s (Minimum requirement + 240ms), allow 8s in the test case.

NOTE 2: The maximum repetition period of the relevant system info blocks that needs to be received by the UE to camp on a cell is 1280ms. The Master Information Block (MIB) is repeated every 8 frame and SIB5 (and SIB11) is segmented into 4 segments where the first segment is scheduled adjacent to the MIB at SIB_POS=40 and the other three segments are scheduled after the MIB (SIB_POS=42, 44 and 46). The maximum time for a UE to read SIB5 will occur if the UE start reading the BCH at the SFN after the MIB located prior to the first segment of SIB5 (SIB_POS 32). Then the UE will not be able to read SIB5 until the second occurrence of SIB5, which will happen at SIB_POS 46 + 1280ms. This gives that the maximum time for the UE to read the relevant system info will be 1420ms ((SIB_POS 46 – SIB_POS 32)*10ms +1280ms).

Specific Message Contents

All messages indicated above shall use the same content as described in the default message content in clause 9 of 34.108 [3], with the following exceptions:

PHYSICAL CHANNEL RECONFIGURATION (Step 3)

Information Element	Value/remark
RRC State Indicator	URA PCH
UTRAN DRX cycle length coefficient	7

Contents of URA UPDATE CONFIRM message for URA_PCH

Information Element	Value/remark
RRC transaction identifier	0
RRC state indicator	URA_PCH
UTRAN DRX cycle length coefficient	7
URA identity	As specified in Table 8.3.7.1.1

8.3.7.1.5 Test requirements

For the test to pass, the total number of successful attempts shall be more than 90% with a confidence level of 95 % of the cases.

Table 8.3.7.1.3: Cell specific test requirements for Cell re-selection in URA_PCH state, one freq. in neighbour list

Parameter	Unit	Cell 1		Cell 2		Cell 3		Cell 4		Cell 5		Cell 6	
		T1	T2	T1	T2	T1	T2	T1	T2	T1	T2	T1	T2
UTRA RF Channel Number		Channel 1		Channel 1		Channel 1		Channel 1		Channel 1		Channel 1	
CPICH_Ec/lor	dB	-9.4		-9.4		-10.5		-10.5		-10.5		-10.5	
PCCPCH_Ec/lor	dB	-11.4		-11.4		-12.5		-12.5		-12.5		-12.5	
SCH_Ec/lor	dB	-11.4		-11.4		-12.5		-12.5		-12.5		-12.5	
PICH_Ec/lor	dB	-14.4		-14.4		-15.5		-15.5		-15.5		-15.5	
OCNS_Ec/lor	dB	-1.10		-1.10		-0.83		-0.83		-0.83		-0.83	
\hat{I}_{or}/I_{oc} Note 1	dB	7.00	10.40	10.40	7.00	0.30		0.30		0.30		0.30	
\hat{I}_{or}	dBm	-63.0	-59.6	-59.6	-63.0	-69.7		-69.7		-69.7		-69.7	
I_{oc}	dBm / 3,84 MHz	-70											
CPICH_Ec/lor Note 1	dB	-15.7	-12.3	-12.3	-15.7	-23.5		-23.5		-23.5		-23.5	

All other parameters and conditions specified in table 8.3.7.1.2 are unchanged.

NOTE 1: These parameters are not directly settable, but are derived by calculation from the settable parameters.

NOTE 2: If the above Test Requirement differs from the Minimum Requirement then the Test Tolerance applied for this test is non-zero. The Test Tolerance for this test is defined in clause F.2 and the explanation of how the Minimum Requirement has been relaxed by the Test Tolerance is given in clause F.4.

8.3.7.2 Two frequencies present in the neighbour list

8.3.7.2.1 Definition and applicability

The cell re-selection delay is defined as the time from a change of cell levels to the moment when this change makes the UE camp on a new cell, and starts to send preambles on the PRACH for the URA UPDATE message with cause value "URA reselection" in the new cell.

The requirements and this test apply to the FDD UE.

8.3.7.2.2 Minimum requirement

The cell re-selection delay shall be less than 8 s with a DRX cycle length of 1.28 s.

The rate of correct cell reselections observed during repeated tests shall be at least 90% with a confidence level of 95 %.

NOTE: The cell re-selection delay can be expressed as: $T_{\text{evaluateFDD}} + T_{\text{SI}}$, where:

$T_{\text{evaluateFDD}}$	See table 4.1 in TS 25.133 [2] clause 4.2.2.
T_{SI}	Maximum repetition period of relevant system info blocks that needs to be received by the UE to camp on a cell. 1280 ms is assumed in this test case.

This gives a total of 7.68 s, allow 8s in the test case.

The normative reference for this requirement is TS 25.133 [2] clauses 5.7.2 and A.5.7.2.

8.3.7.2.3 Test purpose

To verify that the UE meets the minimum requirement and is capable of camping on to a new cell, within the required time, when the preferred cell conditions change.

8.3.7.2.4 Method of test

8.3.7.2.4.1 Initial conditions

Test environment: normal; see clauses G.2.1 and G.2.2.

Frequencies to be tested: mid range; see clause G.2.4.

This scenario implies the presence of 2 carriers and 6 cells as given in tables 8.3.7.2.1 to 8.3.7.2.3. The UE is requested to monitor neighbouring cells on 2 carriers. The maximum repetition period of the relevant system info blocks that needs to be received by the UE to camp on a cell shall be 1 280 ms. In System Information Block Type 2 in cell 1 and cell 2 URA identity is set to different value.

Table 8.3.7.2.1: General test parameters for Cell Re-selection in URA_PCH, two freqs. in neighbour list

Parameter		Unit	Value	Comment
Initial condition	Active cell		Cell2	
	Neighbour cells		Cell1, Cell3, Cell4, Cell5, Cell6	
Final condition	Active cell		Cell1	
SYSTEM INFORMATION BLOCK TYPE 2 - URA identity list - URA identity			0000 0000 0000 0001(B) (Cell 1) 0000 0000 0000 0010(B) (Cell 2)	
Access Service Class (ASC#0) - Persistence value		-	1	Selected so that no additional delay is caused by the random access procedure. The value shall be used for all cells in the test.
HCS				Not used
T _{SI}		ms	1280	See Annex I for the SIB repetition period of system information blocks.
DRX cycle length		s	1,28	The value shall be used for all cells in the test.
T1		s	30	T1 need to be defined so that cell re-selection reaction time is taken into account.
T2		s	15	T2 need to be defined so that cell re-selection reaction time is taken into account.

Table 8.3.7.2.2: Cell specific test parameters for Cell Re-selection in URA_PCH state, two freqs. in neighbour list

Parameter	Unit	Cell 1		Cell 2		Cell 3		Cell 4		Cell 5		Cell 6	
		T1	T2	T1	T2	T1	T2	T1	T2	T1	T2	T1	T2
UTRA RF Channel Number		Channel 1		Channel 2		Channel 1		Channel 1		Channel 2		Channel 2	
CPICH_Ec/Ior	dB	-10		-10		-10		-10		-10		-10	
PCCPCH_Ec/Ior	dB	-12		-12		-12		-12		-12		-12	
SCH_Ec/Ior	dB	-12		-12		-12		-12		-12		-12	
PICH_Ec/Ior	dB	-15		-15		-15		-15		-15		-15	
OCNS_Ec/Ior	dB	-0.941		-0.941		-0.941		-0.941		-0.941		-0.941	
\hat{I}_{or}/I_{oc}	dB	-3.4	2.2	2.2	-3.4	-7.4	-4.8	-7.4	-4.8	-4.8	-7.4	-4.8	-7.4
$\hat{I}_{or(1)}$	dBm	-73.39	-67.75	-67.75	-73.39	-77.39	-74.75	-77.39	-74.75	-74.75	-77.39	-74.75	-77.39
I_{oc}	dBm / 3.84 MHz	-70											
CPICH_Ec/Io	dB	-16	-13	-13	-16	-20		-20		-20		-20	
Propagation Condition		AWGN											
Cell_selection_and_reselection_quality_measure		CPICH E _c /N ₀		CPICH E _c /N ₀		CPICH E _c /N ₀		CPICH E _c /N ₀		CPICH E _c /N ₀		CPICH E _c /N ₀	
Qqualmin	dB	-20		-20		-20		-20		-20		-20	
Qrxlevmin	dBm	-115		-115		-115		-115		-115		-115	
UE_TXPWR_MAX_RACH	dB	21		21		21		21		21		21	
Qoffset2 _{s, n}	dB	C1, C2: 0 C1, C3: 0 C1, C4: 0 C1, C5: 0 C1, C6: 0		C2, C1: 0 C2, C3: 0 C2, C4: 0 C2, C5: 0 C2, C6: 0		C3, C1: 0 C3, C2: 0 C3, C4: 0 C3, C5: 0 C3, C6: 0		C4, C1: 0 C4, C2: 0 C4, C3: 0 C4, C5: 0 C4, C6: 0		C5, C1: 0 C5, C2: 0 C5, C3: 0 C5, C4: 0 C5, C6: 0		C6, C1: 0 C6, C2: 0 C6, C3: 0 C6, C4: 0 C6, C5: 0	
Qhyst2	dB	0		0		0		0		0		0	
Treselection	s	0		0		0		0		0		0	
Sintrasearch	dB	not sent		not sent		not sent		not sent		not sent		not sent	
Sintrasearch	dB	not sent		not sent		not sent		not sent		not sent		not sent	

Note 1 The nominal \hat{I}_{or} values, although not explicitly defined in 25.133 [2] are added here since they are implied and need to be identified so that the test equipment can be configured.

8.3.7.2.4.2 Procedures

- 1) The SS activates cell 1-6 with T1 defined parameters in table 8.3.7.2.3 and monitors cell 1 and 2 for random access requests from the UE.
- 2) The UE is switched on.
- 3) An RRC connection is set up according the generic set-up procedure specified in TS 34.108 [3] subclause 7.3.3 to place the UE in URA_PCH state on cell 2. The SS waits for this process to complete.
- 4) After 30 s from the completion of step 3 or the beginning of T1, the parameters are changed to those defined for T2 in table 8.3.7.2.3.
- 5) If the UE responds on Cell 1 with a PRACH (URA UPDATE message cause "URA reselection") within 8s, then a success is recorded, the SS shall transmit a URA UPDATE CONFIRM message and then the procedure moves to step 7.
- 6) Since the UE has failed to respond with the correct message within the allowed time, a failure is recorded. The SS shall then wait for a total of 15s from the beginning of T2 and if no response is received the UE shall be switched off and the procedure returns to step 1. Otherwise the SS shall transmit a URA UPDATE CONFIRM message and then the procedure continues with step 7.
- 7) After a total of 15 s from the beginning of T2, the parameters are changed to those defined for T1 in table 8.3.7.2.3.
- 8) If the UE responds on Cell 2 with a PRACH (URA UPDATE message cause "URA reselection") within 8s, then a success is recorded and the procedure moves to step 10.
- 9) Since the UE has failed to respond with the correct message within the allowed time, a failure is recorded. The SS shall then wait for a total of 15s from the beginning of T1 and if no response is received the UE shall be switched off and the procedure returns to step 1. Otherwise the SS shall transmit a URA UPDATE CONFIRM message and then the procedure continues with step 10.
- 10) After a total of 15 s from the beginning of T1, the parameters are changed to those defined for T2 in table 8.3.7.2.3.
- 11) Steps 5 to 10 are repeated until the confidence level according to annex F.6.2 is achieved.

NOTE 1: T1 is initially 30 s to allow enough time for the UE to search for cells as it has no prior knowledge of these.

NOTE 2: The time required for receiving all the relevant system information data according to the reception procedure and the RRC procedure delay of system information blocks defined in 25.331 for a UTRAN cell. Since the maximum time to read the relevant system info blocks that needs to be received by the UE to camp on a cell is 1420ms (see note 3) and the maximum RRC procedure delay for reception system information block is 100ms, 1520 ms is assumed in this test case. Therefore this gives a total of 7.82s (Minimum requirement + 240ms), allow 8s in the test case.

NOTE 3: The maximum repetition period of the relevant system info blocks that needs to be received by the UE to camp on a cell is 1280ms. The Master Information Block (MIB) is repeated every 8 frame and SIB5 (and SIB11) is segmented into 4 segments where the first segment is scheduled adjacent to the MIB at SIB_POS=40 and the other three segments are scheduled after the MIB (SIB_POS=42, 44 and 46). The maximum time for a UE to read SIB5 will occur if the UE start reading the BCH at the SFN after the MIB located prior to the first segment of SIB5 (SIB_POS 32). Then the UE will not be able to read SIB5 until the second occurrence of SIB5, which will happen at SIB_POS 46 + 1280ms. This gives that the maximum time for the UE to read the relevant system info will be 1420ms ((SIB_POS 46 – SIB_POS 32)*10ms + 1280ms).

Specific Message Contents

All messages indicated above shall use the same content as described in the default message content in clause 9 of 34.108 [3], with the following exceptions:

PHYSICAL CHANNEL RECONFIGURATION (Step 3)

Information Element	Value/remark
RRC State Indicator	URA_PCH
UTRAN DRX cycle length coefficient	7

Contents of URA UPDATE CONFIRM message for URA_PCH

Information Element	Value/remark
RRC transaction identifier	0
RRC state indicator	URA_PCH
UTRAN DRX cycle length coefficient	7
URA identity	As specified in Table 8.3.7.2.1

8.3.7.2.5 Test requirements

For the test to pass, the total number of successful tests shall be more than 90% of the cases with a confidence level of 95%.

Table 8.3.7.2.3: Cell specific test requirements for Cell re-selection in URA_PCH state, two freqs. in neighbour list

Parameter	Unit	Cell 1		Cell 2		Cell 3		Cell 4		Cell 5		Cell 6	
		T1	T2	T1	T2	T1	T2	T1	T2	T1	T2	T1	T2
UTRA RF Channel Number		Channel 1		Channel 2		Channel 1		Channel 1		Channel 2		Channel 2	
CPICH_Ec/lor	dB	-9.3		-9.3		-10.8		-10.8		-10.8		-10.8	
PCCPCH_Ec/lor	dB	-11.3		-11.3		-12.8		-12.8		-12.8		-12.8	
SCH_Ec/lor	dB	-11.3		-11.3		-12.8		-12.8		-12.8		-12.8	
PICH_Ec/lor	dB	-14.3		-14.3		-15.8		-15.8		-15.8		-15.8	
OCNS_Ec/lor	dB	-1.13		-1.13		-0.77		-0.77		-0.77		-0.77	
\hat{I}_{or}/I_{oc} Note 1	dB	-3.40	+4.80	+4.80	-3.40	-7.40	-3.00	-7.40	-3.00	-3.00	-7.40	-3.00	-7.40
\hat{I}_{or}	dBm	-73.4	-67.0	-67.0	-73.4	-77.4	-74.8	-77.4	-74.8	-74.8	-77.4	-74.8	-77.4
I_{oc}	dBm/ 3.84 MHz	-70.0	-71.8	-71.8	-70.0	-70.0	-71.8	-70.0	-71.8	-71.8	-70.0	-71.8	-70.0
CPICH_Ec/lor Note 1	dB	-15.3	-11.5	-11.5	-15.3	-20.8	-20.8	-20.8	-20.8	-20.8	-20.8	-20.8	-20.8

All other parameters and conditions specified in table 8.3.7.2.2 are unchanged.

NOTE 1: These parameters are not directly settable, but are derived by calculation from the settable parameters.

NOTE 2: If the above Test Requirement differs from the Minimum Requirement then the Test Tolerance applied for this test is non-zero. The Test Tolerance for this test is defined in clause F.2 and the explanation of how the Minimum Requirement has been relaxed by the Test Tolerance is given in clause F.4.

8.3.8 Serving HS-DSCH cell change

8.3.8.1 Definition and applicability

When the UE receives a RRC message implying HS-DSCH cell change with the activation time "now" or earlier than RRC procedure delay seconds from the end of the last TTI containing the RRC command, the UE shall be ready to receive the HS-SCCH channel from the new cell within $D_{\text{cell_change}}$ seconds from the end of the last TTI containing the RRC command.

The requirements and this test apply to Release 6 and later releases for all types of UTRA for the FDD UE that support HSDPA (all categories).

8.3.8.2 Minimum requirement

The UE shall start to transmit the CQI to cell 2 based on the quality of cell 2 less than 74 ms from the beginning of time period T4.

The UE shall also be able to start to receive the first HS-SCCH message from cell 2 less than 74 ms from the beginning of time period T4 and transmit the ACK or NAK which corresponds to the HS-SCCH message.

NOTE: The delay $D_{\text{cell_change}}$ equals the RRC procedure delay defined in TS25.331 Section 13.5.2 plus the interruption time of receiving HS-DSCH data stated in section 5.10.2.2 of TS 25.133.
The RRC procedure delay is 50 ms and the interruption time is given by $T_{\text{interrupt1}} = T_{\text{IU}} + 22 \text{ ms} = 24 \text{ ms}$.

The total delay $D_{\text{cell_change}} = 50 + 24 \text{ ms} = 74 \text{ ms}$

The reference for this requirement is TS 25.133 [2] clauses 5.10.2 and A.5.8.

8.3.8.3 Test purpose

The purpose of this test is to verify the requirement for the delay when performing the serving HS-DSCH cell change in CELL_DCH state specified in section 8.3.8.2.

8.3.8.4 Method of test

The test parameters are given in Table 8.3.8.1, 8.3.8.1a, and 8.3.8.2 below. The test consists of 4 successive time periods, with a time duration of T1, T2, T3 and T4 respectively. At the start of time duration T1 the UE have cell 1 and cell 2 in active set and cell 1 as the serving HS-DSCH cell.

Data shall be transmitted continuously to the UE on the HS-DSCH channel.

Table 8.3.8.1: General test parameters for serving HS-DSCH cell change

Parameter		Unit	Value	Comment
DCH parameters			DL Reference Measurement Channel 12.2 kbps	As specified in section C.3.1
Power Control			On	
Target quality value on DTCH		BLER	0.001	
HSDPA parameters			Fixed Reference Channel Definition H-Set 1, with QPSK modulation only.	As specified in section C.8.1.1
Initial conditions	Active cells		Cell 1 and Cell 2	
	Serving HS-DSCH cell		Cell 1	
Final condition	Active cell		Cell 1 and Cell 2	
	Serving HS-DSCH cell		Cell 2	
Hysteresis		dB	0	
Time to Trigger		ms	0	
Filter coefficient			0	
CQI Feedback cycle, k		ms	2 (0 for cell 1)	
CQI repetition factor			1	
HS-SCCH-1 signalling pattern		-	The six sub-frame HS-SCCH-1 signalling pattern shall be "...XOOXOO...", where "X" indicates TTI in which the HS-SCCH-1 uses the identity of the UE under test, and "O" indicates TTI in which the HS-SCCH-1 uses a different UE identity.	
DPCH Frame offset		256*chip	0	
Default DPCH Offset Value (DOFF)		512*chip	0	
T1		s	5	
T2		s	3	
T3		s	0.5	
T4		ms	100	

Table 8.3.8.1a: Cell specific test parameters for serving HS-DSCH cell change, initial conditions

Parameter	Unit	Cell 1	Cell 2
		T0	T0
UTRA RF Channel Number		Channel 1	Channel 1
CPICH_Ec/Ior	dB	-10	-10
PCCPCH_Ec/Ior	dB	-12	-12
SCH_Ec/Ior	dB	-12	-12
PICH_Ec/Ior	dB	-15	-15
DPCH_Ec/Ior	dB	(Note 1)	N/A
HS-PDSCH_Ec/Ior(Note 3)	dB	-10	-inf
HS-SCCH-1_Ec/Ior(Note 4)	dB	-13	-inf
OCNS_Ec/Ior	dB	(Note 2)	-0.94
\hat{I}_{or} / I_{oc}	dB	3.64	-inf
I_{oc}	dBm/3.84 MHz	-70	
CPICH_Ec/Io	dB	-13	-inf
Propagation Condition		AWGN	
Note 1: The DPCH level is controlled by the power control loop.			
Note 2: The power of the OCNS channel that is added shall make the total power from the cell to be equal to Ior.			
Note 3: E_c / I_{or} value represent the per code power for HS-PDSCH channel.			
Note 4: HS-SCCH-2, HS-SCCH-3, and HS-SCCH-4 are DTX.			

Table 8.3.8.2: Cell specific test parameters for serving HS-DSCH cell change

Parameter	Unit	Cell 1				Cell 2			
		T1	T2	T3	T4	T1	T2	T3	T4
UTRA RF Channel Number		Channel 1				Channel 1			
CPICH_Ec/I _{or}	dB	-10				-10			
PCCPCH_Ec/I _{or}	dB	-12				-12			
SCH_Ec/I _{or}	dB	-12				-12			
PICH_Ec/I _{or}	dB	-15				-15			
DPCH_Ec/I _{or}	dB	Note1	Note1	Note1	N/A	N/A	N/A	Note3	Note1
HS-PDSCH_Ec/I _{or}	dB	-10			-inf	-inf			-10
HS-SCCH-1_Ec/I _{or}	dB	-13			-inf	-inf			-13
OCNS		Note2	Note2	Note2	Note2	Note2	Note2	Note2	Note2
\hat{I}_{or}/I_{oc}	dB	3.64	1.14			1.14	3.64		
I_{oc}	dBm/3.84 MHz	-70							
CPICH_Ec/I _o	dB	-13	-15.5			-15.5	-13		
Propagation Condition		AWGN							
Relative delay of paths received from cell 2 with respect to cell 1	Chips	{-148 ... 148} Note 4							
<p>Note 1: The DPCH level is controlled by the power control loop</p> <p>Note 2: The power of the OCNS channel that is added shall make the total power from the cell to be equal to I_{or}</p> <p>Note 3: The DPCH level is controlled by the power control loop. The initial power shall be set equal to the DPCH_Ec/I_{or} of Cell 1 at the end of T2.</p> <p>Note 4: The relative delay of the path from cell 2 with respect to cell 1 shall always be within ± 148 chip.</p>									

8.3.8.4.1 Initial conditions

Test environment: normal; see clauses G.2.1 and G.2.2.

Frequencies to be tested: mid range; see clause G.2.4.

- 1) Connect the SS (node B emulator) and fader and AWGN noise source to the UE antenna connector as shown in figure A.14.
- 2) Set up an HSDPA call according to TS 34.108 [3] clause 7.3.6 with levels according to T0 in table 8.3.8.1a with cell 1 as serving HS-DSCH cell.
- 3) The information bit data shall be pseudo random and not repeated before 10 different information bit payload blocks are processed. (e.g. Fixed reference Channel Definition H-set 1 (QPSK): The information bit payload block is 9377 bits long. Hence the PRBSequence must be at least $9377 * 10$ bits long.) Use a PRBS from ITU-T O.153 Ref [27]
- 4) Once the HSDPA connection is setup, start transmitting HSDPA Data.

8.3.8.4.2 Procedure

- 1) Turn on cell 2 and set the levels for both cells according to T1 in table 8.3.8.3.
- 2) SS shall send a MEASUREMENT CONTROL message (event 1A, 1B)
- 3) SS shall send a MEASUREMENT CONTROL message (event 1D)
- 4) UE shall send a MEASUREMENT REPORT message triggered by event 1A containing the CFN-SFN observed time difference between cell1 and cell2.
- 5) SS shall send an ACTIVE SET UPDATE message with activation time "now ", adding cell 2 to the active set
- 6) UE shall send a ACTIVE SET UPDATE COMPLETE message
- 7) After 5 seconds from the beginning of T1, the SS shall switch the power settings from T1 to T2 according to the parameters defined in table 8.3.8.3.
- 8) During time period T2, UE shall transmit a MEASUREMENT REPORT message (intra frequency) triggered by event 1D for cell 2.
- 9) After 3 seconds from the beginning of T2, the SS shall switch the power settings from T2 to T3 according to the parameters defined in table 8.3.8.3.
- 10) During T3, no CQI measurements shall be reported by the UE.
- 11) SS shall transmit a PHYSICAL CHANNEL RECONFIGURATION message (cell 2 HS-DSCH serving cell) with activation time set to "now" changing serving HS-DSCH from cell 1 to cell 2. The start of T4 is defined as the end of the last TTI containing the physical channel reconfiguration message.
- 12) The SS shall switch the power settings from T3 to T4 in table 8.3.8.3 and immediately start transmitting HSDPA Data on cell 2. The SS shall not send any HSDPA data on cell 1 after the start of T4.
- 13) The SS shall measure the time from start of T4 until the start of the HS-DPCCH subframe where the UE starts transmitting CQI measurements on cell 2
- 14) The SS shall measure the time from start of T4 until the start of the HS-DPCCH subframe where the UE starts transmitting ACK/NAK. The SS shall not start to monitor the HS-DPCCH for ACK/NAK until one frame after the start of T4 to eliminate the risk of detecting the ACK/NAK for cell 1.
- 15) If steps 10, 13 and 14 fulfill the test requirements, then the number of successful tests is increased by one.
- 16) The UE shall transmit a PHYSICAL CHANNEL RECONFIGURATION COMPLETE message on the UL DCCH of cell 2.
- 17) SS shall transmit a PHYSICAL CHANNEL RECONFIGURATION message (cell 1 HS-DSCH serving cell) with activation time set to "now" changing serving HS-DSCH back to cell 1.

- 18) The SS shall switch the power settings from T4 to T1 in table 8.3.8.3. The start of T1 is defined as the end of the last TTI containing the physical channel reconfiguration message.
- 19) The SS shall start transmitting HSDPA Data on cell 1 and shall not send any HSDPA data on cell 2.
- 20) During T1, the UE may transmit a MEASUREMENT REPORT message (intra frequency) triggered by event 1D for cell 1 and may also transmit a MEASUREMENT REPORT message (intra frequency) triggered by event 1B for cell 2.
- 21) Repeat step 7-20 until the confidence level according to annex F.6.2 is achieved

Specific Message Contents

The default messages for SIB11 and SIB12 as specified for Cell 1 and Cell 2 in clause 6.1.4 of 34.108 [3] are used.

Default parameters according to Cell 1 and Cell 2 in clause 6.1.4.

All messages indicated above shall use the same content as described in the default message content in clause 9 of 34.108 [3], with the following exceptions:

MEASUREMENT CONTROL message (event 1A, 1B)

Information Element/Group name	Value/Remark
Message Type (10.2.17)	
UE information elements -RRC transaction identifier -Integrity check info -message authentication code -RRC message sequence number	0 SS calculates the value of MAC-I for this message and writes to this IE. The first/ leftmost bit of the bit string contains the most significant bit of the MAC-I. SS provides the value of this IE, from its internal counter.
Measurement Information elements -Measurement Identity -Measurement Command (10.3.7.46) -Measurement Reporting Mode (10.3.7.49) -Measurement Report Transfer Mode -Periodical Reporting / Event Trigger Reporting Mode -Additional measurements list (10.3.7.1)	1 Modify AM RLC Event trigger Not Present
-CHOICE <i>Measurement type</i> -Intra-frequency measurement (10.3.7.36) -Intra-frequency measurement objects list (10.3.7.33) -Intra-frequency measurement quantity (10.3.7.38) -Filter coefficient (10.3.7.9) -CHOICE mode -Measurement quantity -Intra-frequency reporting quantity (10.3.7.41)	Intra-frequency measurement Not Present 0 FDD CPICH_Ec/N0
-Reporting quantities for active set cells (10.3.7.5) -Cell synchronisation information reporting indicator -Cell Identity reporting indicator -CHOICE mode -CPICH Ec/N0 reporting indicator -CPICH RSCP reporting indicator -Pathloss reporting indicator	TRUE (Note 1) TRUE FDD TRUE TRUE FALSE
-Reporting quantities for monitored set cells (10.3.7.5) -Cell synchronisation information reporting indicator -Cell Identity reporting indicator -CHOICE mode -CPICH Ec/N0 reporting indicator -CPICH RSCP reporting indicator -Pathloss reporting indicator	TRUE (Note 1) TRUE FDD TRUE TRUE FALSE
-Reporting quantities for detected set cells (10.3.7.5)	Not Present
-Reporting cell status (10.3.7.61) -Measurement validity (10.3.7.51) -CHOICE report criteria -Intra-frequency measurement reporting criteria (10.3.7.39) -Parameters required for each event	Not Present Not Present Intra-frequency measurement reporting criteria 2
-Intra-frequency event identity -Triggering condition 2 -Reporting Range Constant -Cells forbidden to affect Reporting Range -W -Hysteresis -Threshold used frequency -Reporting deactivation threshold -Replacement activation threshold -Time to trigger -Amount of reporting -Reporting interval -Reporting cell status	Event 1A Monitored set cells 3 dB Not Present 1.0 0 dB Not Present 0 Not Present 0 ms Infinity 0 ms (Note 2)
- CHOICE reported cell - Maximum number of reported cells	Report cell within active set and/or monitored set cells on used frequency 3
-Intra-frequency event identity -Triggering condition 1 -Reporting Range Constant	Event 1B Active set cells 3 dB

Information Element/Group name	Value/Remark
-Cells forbidden to affect Reporting Range -W -Hysteresis -Threshold used frequency -Reporting deactivation threshold -Replacement activation threshold -Time to trigger -Amount of reporting -Reporting interval -Reporting cell status - CHOICE reported cell - Maximum number of reported cells	Not Present 1.0 0 dB Not Present Not Present Not Present 0 ms Not Present Not Present Report cell within active set and/or monitored set cells on used frequency 3
Physical channel information elements	
-DPCH compressed mode status info (10.3.6.34)	Not Present
Note 1: The SFN-CFN observed time difference is calculated from the OFF and Tm parameters contained in the IE "Cell synchronisation information ", TS 25.331, clause 10.3.7.6. According to TS 25.331, 8.6.7.7, this IE is included in MEASUREMENT REPORT if IE "Cell synchronisation information reporting indicator" in IE "Cell reporting quantities" TS 25.331, clause 10.3.7.5 is set to TRUE in MEASUREMENT CONTROL.	
Note 2: Reporting interval = 0 ms means no periodical reporting	

MEASUREMENT CONTROL (event 1D):

Use the same message as specified in 34.108 except for the following:

Information Element	Value/remark
Measurement identity	2
Measurement command	Setup
- CHOICE measurement type	Intra-frequency measurement
- Intra-frequency measurement objects list	Not present
- Intra-frequency measurement quantity	
- Filter coefficient	0
- CHOICE mode	FDD
- Measurement quantity	CPICH RSCP
- Intra-frequency reporting quantity	
- Reporting quantities for active set cells	
- Cell synchronisation information reporting	FALSE
indicator	
- Cell Identity reporting indicator	FALSE
- CPICH Ec/NO reporting indicator	TRUE
- CPICH RSCP reporting indicator	TRUE
- Pathloss reporting indicator	FALSE
- Reporting quantities for monitored set cells	
- Cell synchronisation information reporting	FALSE
indicator	
- Cell Identity reporting indicator	FALSE
- CPICH Ec/NO reporting indicator	FALSE
- CPICH RSCP reporting indicator	FALSE
- Pathloss reporting indicator	FALSE
- Reporting quantities for detected set cells	Not Present
- Reporting cell status	Not present
- Measurement validity	Not present
- CHOICE report criteria	Intra-frequency measurement reporting criteria
- Parameters required for each event	
- Intra-frequency event identity	1D
- Triggering condition 2	Active set cells
- Hysteresis	0
- Time to trigger	0
- Reporting cell status	
- CHOICE reported cell	Report cells within active set
- Maximum number of reported cells	3
- Use CIO	FALSE
Measurement reporting mode	
- Measurement reporting transfer mode	Acknowledged mode RLC
- Periodic reporting / Event trigger reporting mode	Event trigger
Additional measurement list	Not present
DPCH compressed mode status info	Not present

ACTIVE SET UPDATE message:

Information Element/Group name	Type and reference	Value/Remark
Message Type	Message Type	
UE information elements		
-RRC transaction identifier	RRC transaction identifier 10.3.3.36	0
-Integrity check info	Integrity check info 10.3.3.16	
-message authentication code		SS calculates the value of MAC-I for this message and writes to this IE. The first/ leftmost bit of the bit string contains the most significant bit of the MAC-I.
-RRC message sequence number		SS provides the value of this IE, from its internal counter.
-Integrity protection mode info	Integrity protection mode info 10.3.3.19	Not Present
-Cipherng mode info	Cipherng mode info 10.3.3.5	Not Present
-Activation time	Activation time 10.3.3.1	"now".

Information Element/Group name	Type and reference	Value/Remark
-New U-RNTI	U-RNTI 10.3.3.47	Not Present
CN information elements		
-CN Information info	CN Information info 10.3.1.3	Not Present
Phy CH information elements		
Uplink radio resources		
-Maximum allowed UL TX power	Maximum allowed UL TX power 10.3.6.39	33 dBm
Downlink radio resources		
-Radio link addition information	Radio link addition information 10.3.6.68	Radio link addition information required for each RL to add
-Primary CPICH info	Primary CPICH info 10.3.6.60	Same as defined in cell2
-Downlink DPCH info for each RL	Downlink DPCH info for each RL 10.3.6.21	
-CHOICE mode		
-FDD		
-Primary CPICH usage for channel estimation	Primary CPICH usage for channel estimation 10.3.6.62	Primary CPICH may be used
-DPCH frame offset	Integer(0..38144 by step of 256)	This should be reflected by the IE" Cell synchronisation information" in received MEASUREMENT REPORT message
-Secondary CPICH info	Secondary CPICH info 10.3.6.73	Not Present
-DL channelisation code		
-Secondary scrambling code	Secondary scrambling code 10.3.6.74	Not Present
-Spreading factor	Integer(4, 8, 16, 32, 64, 128, 256, 512)	128
-Code number	Integer(0..Spreading factor - 1)	96
-Scrambling code change	Enumerated (code change, no code change)	No code change
-TPC combination index	TPC combination index 10.3.6.85	0
-Closed loop timing adjustment mode	Integer(1, 2)	Not Present
-TFCI combining indicator	TFCI combining indicator 10.3.6.81	FALSE
-SCCPCH Information for FACH	SCCPCH Information for FACH 10.3.6.70	Not Present
Radio link removal information		Radio link removal information required for each RL to remove
-Radio link removal information	Radio link removal information 10.3.6.69	Not Present
-TX Diversity Mode	TX Diversity Mode 10.3.6.86	None

Contents of PHYSICAL CHANNEL RECONFIGURATION message (cell 2 HS-DSCH serving cell):

Information Element	Value/remark
Message Type	
RRC transaction identifier	Arbitrarily selects an integer between 0 and 3
Integrity check info	
- message authentication code	SS calculates the value of MAC-I for this message and writes to this IE. The first/ leftmost bit of the bit string contains the most significant bit of the MAC-I.
- RRC message sequence number	SS provides the value of this IE, from its internal counter.
Integrity protection mode info	Not Present
Ciphering mode info	Not Present
Activation time	Not Present
Delay restriction flag	Not Present
New U-RNTI	Not Present
New C-RNTI	Not Present
New H-RNTI	'0101 0101 0101 0101'
New Primary E-RNTI	Not Present
New Secondary E-RNTI	Not Present
RRC State indicator	CELL_DCH
UTRAN DRX cycle length coefficient	Not Present
CN information info	Not Present
URA identity	Not Present
Downlink counter synchronization info	Not Present
Frequency info	Not present

Information Element	Value/remark
Maximum allowed UL TX power	Not present
CHOICE <i>channel requirement</i>	Uplink DPCH info
- Uplink DPCH power control info	
- DPCH power offset	-40 (-80dB)
- PC Preamble	1 frame
- SRB delay	7 frames
- Power Control Algorithm	Algorithm1
- TPC step size	0 (1dB)
- Δ_{ACK}	3
- Δ_{NACK}	3
- Ack-Nack repetition factor	1
- Scrambling code type	Long
- Scrambling code number	0 (0 to 16777215)
- Number of DPDCH	Not Present(1)
- spreading factor	64
- TFCI existence	TRUE
- Number of FBI bit	Not Present(0)
- Puncturing Limit	1
E-DCH Info	Not Present
CHOICE Mode	FDD
Downlink HS-PDSCH Information	
- HS-SCCH Info	
- CHOICE mode	FDD
- DL Scrambling Code	Not present
- HS-SCCH Channelisation Code Information	
- HS-SCCH Channelisation Code	2
- HS-SCCH Channelisation Code	3
- HS-SCCH Channelisation Code	6
- HS-SCCH Channelisation Code	7
- Measurement Feedback Info	
- CHOICE mode	FDD
- Measurement Power Offset	12 (6 dB)
- CQI Feedback cycle, k	2 ms
- CQI repetition factor	1
- Δ_{CQI}	5 (corresponds to 0dB in relative power offset)
- CHOICE mode	FDD (no data)
Downlink information common for all radio links	
- Downlink DPCH info common for all RL	
- Timing indicator	Maintain
- CFN-targetSFN frame offset	Not Present
- Downlink DPCH power control information	
- DPC mode	0 (single)
- CHOICE mode	FDD
- Power offset $P_{Pilot-DPCH}$	0
- DL rate matching restriction information	Not Present
- Spreading factor	Reference to clause 6.10 Parameter Set
- Fixed or Flexible Position	Reference to clause 6.10 Parameter Set
- TFCI existence	Reference to clause 6.10 Parameter Set
- CHOICE SF	Reference to clause 6.10 Parameter Set
- DPCH compressed mode info	Not Present
- TX Diversity mode	None
- Default DPCH Offset Value	Not Present
- MAC-hs reset indicator	Not Present

Information Element	Value/remark
- Downlink information for each radio link - Choice mode - Primary CPICH info - Primary scrambling code - Cell ID - Serving HS-DSCH radio link indicator - Downlink DPCH info for each RL	(for cell 1) FDD Same as defined in cell1 Not Present FALSE Not present
- Downlink information for each radio link - Choice mode - Primary CPICH info - Primary scrambling code - Serving HS-DSCH radio link indicator - Downlink DPCH info for each RL - CHOICE mode - Primary CPICH usage for channel estimation - DPCH frame offset - Secondary CPICH info - DL channelisation code - Secondary scrambling code - Spreading factor - Code number - Scrambling code change - TPC combination index - Closed loop timing adjustment mode	(for cell 2) FDD Same as defined in cell2 TRUE FDD Primary CPICH may be used Set to value Default DPCH Offset Value (as currently stored in SS) mod 38 400 Not Present Not present 128 96 No change 0 Not Present
MBMS PL Service Restriction Information	Not Present

Contents of PHYSICAL CHANNEL RECONFIGURATION message (cell 1 HS-DSCH serving cell):

Information Element	Value/remark
Message Type	
RRC transaction identifier	Arbitrarily selects an integer between 0 and 3
Integrity check info	
- message authentication code	SS calculates the value of MAC-I for this message and writes to this IE. The first/ leftmost bit of the bit string contains the most significant bit of the MAC-I.
- RRC message sequence number	SS provides the value of this IE, from its internal counter.
Integrity protection mode info	Not Present
Ciphering mode info	Not Present
Activation time	Not Present
Delay restriction flag	Not Present
New U-RNTI	Not Present
New C-RNTI	Not Present
New H-RNTI	'0101 0101 0101 0101'
New Primary E-RNTI	Not Present
New Secondary E-RNTI	Not Present
RRC State indicator	CELL_DCH
UTRAN DRX cycle length coefficient	Not Present
CN information info	Not Present
URA identity	Not Present
Downlink counter synchronization info	Not Present
Frequency info	Not present
Maximum allowed UL TX power	Not present
CHOICE <i>channel requirement</i>	Uplink DPCH info
- Uplink DPCH power control info	
- DPCCH power offset	-40 (-80dB)
- PC Preamble	1 frame
- SRB delay	7 frames
- Power Control Algorithm	Algorithm1
- TPC step size	0 (1dB)
- Δ_{ACK}	3
- Δ_{NACK}	3
- Ack-Nack repetition factor	1
- Scrambling code type	Long

Information Element	Value/remark
- Scrambling code number	0 (0 to 16777215)
- Number of DPDCH	Not Present(1)
- spreading factor	64
- TFCI existence	TRUE
- Number of FBI bit	Not Present(0)
- Puncturing Limit	1
E-DCH Info	Not Present
CHOICE Mode	FDD
Downlink HS-PDSCH Information	
- HS-SCCH Info	
- CHOICE mode	FDD
- DL Scrambling Code	Not present
- HS-SCCH Channelisation Code Information	
- HS-SCCH Channelisation Code	2
- HS-SCCH Channelisation Code	3
- HS-SCCH Channelisation Code	6
- HS-SCCH Channelisation Code	7
- Measurement Feedback Info	
- CHOICE mode	FDD
- Measurement Power Offset	12 (6 dB)
- CQI Feedback cycle, k	0
- CQI repetition factor	1
- Δ_{CQI}	5 (corresponds to 0dB in relative power offset)
- CHOICE mode	FDD (no data)
Downlink information common for all radio links	
- Downlink DPCH info common for all RL	
- Timing indicator	Maintain
- CFN-targetSFN frame offset	Not Present
- Downlink DPCH power control information	
- DPC mode	0 (single)
- CHOICE mode	FDD
- Power offset $P_{Pilot-DPCH}$	0
- DL rate matching restriction information	Not Present
- Spreading factor	Reference to clause 6.10 Parameter Set
- Fixed or Flexible Position	Reference to clause 6.10 Parameter Set
- TFCI existence	Reference to clause 6.10 Parameter Set
- CHOICE SF	Reference to clause 6.10 Parameter Set
- DPCH compressed mode info	Not Present
- TX Diversity mode	None
- Default DPCH Offset Value	Not Present
- MAC-hs reset indicator	Not Present
- Downlink information for each radio link	(for cell 2)
- Choice mode	FDD
- Primary CPICH info	
- Primary scrambling code	Same as defined in cell 2
- Cell ID	Not Present
- Serving HS-DSCH radio link indicator	FALSE
- Downlink DPCH info for each RL	Not present
- Downlink information for each radio link	(for cell 1)
- Choice mode	FDD
- Primary CPICH info	
- Primary scrambling code	Same as defined in cell 1
- Serving HS-DSCH radio link indicator	TRUE
- Downlink DPCH info for each RL	
- CHOICE mode	FDD
- Primary CPICH usage for channel estimation	Primary CPICH may be used
- DPCH frame offset	Set to value Default DPCH Offset Value (as currently stored in SS) mod 38 400
- Secondary CPICH info	Not Present
- DL channelisation code	
- Secondary scrambling code	Not present
- Spreading factor	128
- Code number	96
- Scrambling code change	No change
- TPC combination index	0
- Closed loop timing adjustment mode	Not Present
MBMS PL Service Restriction Information	Not Present

MEASUREMENT REPORT message

This message is common for all intra-frequency test cases and are described in Annex I.

8.3.8.5 Test requirements

For the test to pass, the total number of successful tests shall be more than 90% of the cases with a confidence level of 95 %.

Table 8.3.8.2a: Cell specific test parameters for serving HS-DSCH cell change, initial conditions

Parameter	Unit	Cell 1	Cell 2
		T0	T0
UTRA RF Channel Number		Channel 1	Channel 1
CPICH_Ec/Ior	dB	-9.3	-9.3
PCCPCH_Ec/Ior	dB	-11.3	-11.3
SCH_Ec/Ior	dB	-11.3	-11.3
PICH_Ec/Ior	dB	-14.3	-14.3
DPCH_Ec/Ior	dB	(Note 1)	N/A
HS-PDSCH_Ec/Ior(Note 3)	dB	-9.3	-inf
HS-SCCH-1_Ec/Ior(Note 4)	dB	-12.3	-inf
OCNS_Ec/Ior	dB	(Note 2)	-1.13
\hat{I}_{or} / I_{oc}	dB	3.64	-inf
I_{oc}	dBm/3.84 MHz	-70	
CPICH_Ec/Io	dB	-12.3	-inf
Propagation Condition		AWGN	
Note 1:	The DPCH level is controlled by the power control loop.		
Note 2:	The power of the OCNS channel that is added shall make the total power from the cell to be equal to Ior.		
Note 3:	E_c / I_{or} value represent the per code power for HS-PDSCH channel.		
Note 4:	HS-SCCH-2, HS-SCCH-3, and HS-SCCH-4 are DTX.		

Table 8.3.8.3: Cell specific test parameters for serving HS-DSCH cell change

Parameter	Unit	Cell 1				Cell 2			
		T1	T2	T3	T4	T1	T2	T3	T4
UTRA RF Channel Number		Channel 1				Channel 1			
CPICH_Ec/I _{or}	dB	-9.3				-9.3			
PCCPCH_Ec/I _{or}	dB	-11.3				-11.3			
SCH_Ec/I _{or}	dB	-11.3				-11.3			
PICH_Ec/I _{or}	dB	-14.3				-14.3			
DPCH_Ec/I _{or}	dB	Note1	Note1	Note1	N/A	N/A	N/A	Note3	Note1
HS-PDSCH_Ec/I _{or} Note 5	dB	-9.3			-inf	-inf			-9.3
HS-SCCH-1_Ec/I _{or} Note 6	dB	-12.3			-inf	-inf			-12.3
OCNS		Note2	Note2	Note2	Note2	Note2	Note2	Note2	Note2
\hat{I}_{or}/I_{oc}	dB	3.64	1.14			1.14	3.64		
I_{oc}	dBm/3.84 MHz	-70							
CPICH_Ec/I _o	dB	-12.3	-14.8			-14.8	-12.3		
Propagation Condition		AWGN							
Relative delay of paths received from cell 2 with respect to cell 1	Chips	{-147.5 ... 147.5} Note 4							
<p>Note 1: The DPCH level is controlled by the power control loop</p> <p>Note 2: The power of the OCNS channel that is added shall make the total power from the cell to be equal to I_{or}</p> <p>Note 3: The DPCH level is controlled by the power control loop. The initial power shall be set equal to the DPCH_Ec/I_{or} of Cell 1 at the end of T2.</p> <p>Note 4: The relative delay of the path from cell 2 with respect to cell 1 shall always be within ± 147.5 chip.</p> <p>Note 5: E_c/I_{or} value represent the per code power for HS-PDSCH channel.</p> <p>Note 6: HS-SCCH-2, HS-SCCH-3, and HS-SCCH-4 are DTX.</p>									

The delay from the start of the HS-DSCH sub frame until the start of the corresponding UL HS-DPCCH is 5.3 ms. The test requirement for ACK/NAK shall be increased by this delay. This delay is not relevant for CQI reporting.

The maximum uncertainty of delay due to not scheduling any data to the UE is 2 HS-SCCH sub frames for HS-SCCH signalling pattern used (up to 2 consecutive sub frames not allocated to the UE), the test requirement for ACK/NAK shall be increased by this delay. This delay is not relevant for CQI reporting.

Step 10: No CQI reports shall be sent prior to serving cell change. The reason is that the source of the CQI reports (which cell it is calculated from) can not be determined, and the test must therefore verify that no CQI reports are transmitted based on cell 1 measurements.

Step 13: Time from end of last frame of the serving cell change command to the sub frame of HS-DPCCH where CQI is starting shall be less than $74 \text{ ms} + T_0 * T_{\text{chip}} = 74.3 \text{ ms}$. Allow 75 ms in the test.

Step 14: Time from end of last frame of the serving cell change command to the sub frame of HS-DPCCH where ACK/NAK is starting shall be less than $74 \text{ ms} + 7.5 * T_{\text{slot}} + T_0 * T_{\text{chip}} + 2 * T_{\text{subframe}} = 74 + 9.3 = 83.3 \text{ ms}$. Allow 85 ms in the test.

Note: If the above Test Requirement differs from the Minimum Requirement then the Test Tolerance applied for this test is non-zero. The Test Tolerance for this test is defined in clause F.2 and the explanation of how the Minimum Requirement has been relaxed by the Test Tolerance is given in clause F.4.

8.4 RRC Connection Control

8.4.1 RRC Re-establishment delay

8.4.1.1 Test 1

8.4.1.1.1 Definition and applicability

The UE Re-establishment delay requirement ($T_{\text{UE-RE-ESTABLISH-REQ}}$) is defined as the time between the moment when radio link failure is considered by the UE, to when the UE starts to send preambles on the PRACH.

$T_{\text{UE-RE-ESTABLISH-REQ}}$ is depending on whether the target cell is known by the UE or not. A cell is known if either or both of the following conditions are true:

- the UE has had radio links connected to the cell in the previous (old) active set.
- the cell has been measured by the UE during the last 5 seconds.

The phase reference is the primary CPICH.

The requirements of this test apply to the FDD UE.

8.4.1.1.2 Minimum requirement

The Re-establishment delay $T_{\text{RE-ESTABLISH}}$ to a known cell shall be less than 1.9 s.

The rate of correct RRC re-establishments observed during repeated tests shall be at least 90%.

NOTE: The Re-establishment delay in this case can be expressed as

$$T_{\text{RE-ESTABLISH}} = T_{\text{RRC-RE-ESTABLISH}} + T_{\text{UE-RE-ESTABLISH-REQ-KNOWN}}$$

where

$$T_{\text{RRC-RE-ESTABLISH}} = 160 \text{ ms} + (N_{313} - 1) * 10 \text{ ms} + T_{313}$$

$$T_{\text{UE-RE-ESTABLISH-REQ-KNOWN}} = 50 \text{ ms} + T_{\text{search}} + T_{\text{SI}} + T_{\text{RA}}$$

$$N_{313} = 20$$

$$T_{313} = 0 \text{ s}$$

$$T_{\text{search}} = 100 \text{ ms}$$

T_{RA} = The additional delay caused by the random access procedure. 40 ms is assumed in this test case.

T_{SI} is the time required for receiving all the relevant system information data according to the reception procedure and the RRC procedure delay of system information blocks defined in 25.331 for a UTRAN cell (ms). 1280 ms is assumed in this test case.

This gives a total of 1820ms, allow 1.9s in the test case.

8.4.1.1.3 Test purpose

To verify that the UE meets the minimum requirement.

8.4.1.1.4 Method of test

8.4.1.1.4.1 Initial conditions

Test environment: normal; see clauses G.2.1 and G.2.2.

Frequencies to be tested: mid range; see clause G.2.4.

The test parameters are given in table 8.4.1.1, table 8.4.1.1.A , and table 8.4.1.2 below. The maximum repetition period of the relevant system info blocks that needs to be received by the UE to camp on a cell shall be 1280 ms. And DRX cycle length shall be 1280ms. In the measurement control information it is indicated to the UE that periodic reporting shall be used. The test consist of 2 successive time periods, with a time duration of T1 and T2 respectively. At the start of time period T2, the dedicated channel is removed.

Table 8.4.1.1 General test parameters for RRC re-establishment delay, Test 1

Parameter	Unit	Value	Comment
DCH Parameters		DL and UL Reference measurement channel 12.2 kbps	As specified in clause C.3.1 and C.2.1
Power Control		On	
Active cell, Initial condition		Cell 1	
Active cell, Final condition		Cell 2	
N313		20	
N315		1	
T313	Seconds	0	
Monitored cell list size		24	Monitored set shall only include intra frequency neighbours. NOTE: See Annex I for cell information.
Cell 2			Included in the monitored set
T_{SI}	ms	1280	See Annex I for the SIB repetition period of system information blocks.
Reporting frequency	Seconds	4	
T1	s	10	
T2	s	6	

Table 8.4.1.1.A Cell specific parameters for RRC re-establishment delay test, Test 1

Parameter	Unit	Cell 1		Cell 2	
		T0		T0	
Cell Frequency	ChNr	1		1	
CPICH_Ec/Ior	dB	-10		-10	
PCCPCH_Ec/Ior	dB	-12		-12	
SCH_Ec/Ior	dB	-12		-12	
PICH_Ec/Ior	dB	-15		-15	
DCH_Ec/Ior	dB	Note 1		-infinity	
OCNS_Ec/Ior	dB	Note 2		-0.941	
\hat{I}_{or}/I_{oc}	dB	2.39		-infinity	
I_{oc}	dBm/ 3.84 MHz	-70			
CPICH_Ec/Io	dB	-12		-infinity	
Propagation Condition		AWGN			
Note 1: The DPCH level is controlled by the power control loop.					
Note 2: The power of the OCNS channel that is added shall make the total power from the cell to be equal to I_{or} .					

Table 8.4.1.2 Cell specific parameters for RRC re-establishment delay test, Test 1

Parameter	Unit	Cell 1		Cell 2	
		T1	T2	T1	T2
Cell Frequency	ChNr	1		1	
CPICH_Ec/Ior	dB	-10		-10	
PCCPCH_Ec/Ior	dB	-12		-12	
SCH_Ec/Ior	dB	-12		-12	
PICH_Ec/Ior	dB	-15		-15	
DCH_Ec/Ior	dB	Note 1	-Infinity	Not applicable	
OCNS_Ec/Ior	dB	Note 2	-0.941	-0.941	
\hat{I}_{or}/I_{oc}	dB	2,39	-Infinity	4,39	0,02
I_{oc}	dBm/ 3.84 MHz	-70			
CPICH_Ec/Io	dB	-15	-Infinity	-13	
Propagation Condition		AWGN			
Note 1: The DPCH level is controlled by the power control loop.					
Note 2: The power of the OCNS channel that is added shall make the total power from the cell to be equal to I_{or} .					

8.4.1.1.4.2 Procedure

- 1) The RF parameters are set up according to T0.
- 2) The UE is switched on.
- 3) A call is set up according to the test procedure specified in TS 34.108 [3] subclause 7.3.4 without Compressed mode parameters.
- 4) The RF parameters are setup according to T1.
- 5) 10 s after step4 has completed, the parameters are changed to that as described for T2.
- 6) If the UE responds on cell 2 within 2.1 s from the beginning of time period T2 with a CELL_UPDATE command then the number of successful tests is increased by one.
- 7) SS shall transmit a RRC CONNECTION RELEASE message to make the UE transit to idle mode.
- 8) After 6 seconds from the beginning of time period T2, the RF parameters are set up according to T0.
- 9) The SS shall wait for 30s to make the UE complete cell reselection to cell1.
- 10) Repeat step 3-9 until the confidence level according to annex F.6.2 is achieved.

NOTE 1: The time required for receiving all the relevant system information data according to the reception procedure and the RRC procedure delay of system information blocks is defined in 25.331 for a UTRAN cell. Since the maximum time to read the relevant system info blocks that needs to be received by the UE to camp on a cell is 1420ms (see note 2) and the maximum RRC procedure delay for reception system information block is 100ms, 1520ms is assumed in this test case. Therefore this gives a total of 2060ms (Minimum requirement + 240ms), allow 2.1s in the test case.

NOTE 2: The maximum repetition period of the relevant system info blocks that needs to be received by the UE to camp on a cell is 1280ms. The Master Information Block (MIB) is repeated every 8 frame and SIB5 (and SIB11) is segmented into 4 segments where the first segment is scheduled adjacent to the MIB at SIB_POS=40 and the other three segments are scheduled after the MIB (SIB_POS=42, 44 and 46). The maximum time for a UE to read SIB5 will occur if the UE start reading the BCH at the SFN after the MIB located prior to the first segment of SIB5 (SIB_POS 32). Then the UE will not be able to read SIB5 until the second occurrence of SIB5, which will happen at SIB_POS 46 + 1280ms. This gives that the maximum time for the UE to read the relevant system info will be 1420ms ((SIB_POS 46 – SIB_POS 32)*10ms +1280ms).

All messages indicated above shall use the same content as described in the default message content in clause 9 of 34.108 [3], with the following exceptions:

Contents of RRC CONNECTION RELEASE message UM (Step 7):

Information Element	Value/remark	Version
Release cause	Re-establishment Reject	

8.4.1.1.5 Test requirements

For the test to pass, the total number of successful tests shall be more than 90% of the cases with a confidence level of 95%.

Note: If the above Test Requirement differs from the Minimum Requirement then the Test Tolerance applied for this test is non-zero. The Test Tolerance for this test is defined in clause F.2 and the explanation of how the Minimum Requirement has been relaxed by the Test Tolerance is given in clause F.4.

8.4.1.2 Test 2

8.4.1.2.1 Definition and applicability

The UE Re-establishment delay requirement ($T_{UE-E-ESTABLISH-REQ}$) is defined as the time between the moment when radio link failure is considered by the UE, to when the UE starts to send preambles on the PRACH.

$T_{UE-RE-ESTABLISH-REQ}$ is depending on whether the target cell is known by the UE or not. A cell is known if either or both of the following conditions are true:

- the UE has had radio links connected to the cell in the previous (old) active set.
- the cell has been measured by the UE during the last 5 seconds.

The phase reference is the primary CPICH.

The requirements of this test apply to the FDD UE.

8.4.1.2.2 Minimum requirement

The rate of correct RRC re-establishments observed during repeated tests shall be at least 90%.

NOTE: The Re-establishment delay in this case can be expressed as

$$T_{RE-ESTABLISH} = T_{RRC-RE-ESTABLISH} + T_{UE-RE-ESTABLISH-REQ-UNKNOWN}$$

where

$$T_{RRC-RE-ESTABLISH} = 160\text{ms} + (N_{313} - 1) * 10\text{ms} + T_{313}$$

$$T_{UE-RE-ESTABLISH-REQ-UNKNOWN} = 50\text{ms} + T_{\text{search}} * NF + T_{SI} + T_{RA}$$

N_{313} =	20
T_{313} =	0s
T_{search} =	800ms
NF	is the number of different frequencies in the monitored set. 3 frequencies are assumed in this test case.
T_{RA} =	The additional delay caused by the random access procedure. 40 ms is assumed in this test case.
T_{SI}	is the time required for receiving all the relevant system information data according to the reception procedure and the RRC procedure delay of system information blocks defined in 25.331 for a UTRAN cell (ms).1280 ms is assumed in this test case.

This gives a total of 4120ms, allow 4.2s in the test case.

8.4.1.2.3 Test purpose

To verify that the UE meets the minimum requirement.

8.4.1.2.4 Method of test

8.4.1.2.4.1 Initial conditions

Test environment: normal; see clauses G.2.1 and G.2.2.

Frequencies to be tested: mid range; see clause G.2.4.

The test parameters are given in table 8.4.1.3 and table 8.4.1.4 below. The maximum repetition period of the relevant system info blocks that needs to be received by the UE to camp on a cell shall be 1280 ms. And DRX cycle length shall be 1280ms. In the measurement control information it is indicated to the UE that periodic reporting shall be used. The test consists of 2 successive time periods, with a time duration of T1 and T2 respectively. At the start of time period T2, the dedicated channel is removed.

Table 8.4.1.3 General test parameters for RRC re-establishment delay, Test 2

Parameter	Unit	Value	Comment
DCH Parameters		DL and UL Reference measurement channel 12.2 kbps	As specified in clause C.3.1 and C.2.1
Power Control		On	
Active cell, initial condition		Cell 1	
Active cell, final condition		Cell 2	
N_{313}		20	
N_{315}		1	
T_{313}	Seconds	0	
Monitored cell list size		24	Monitored set shall include 2 additional frequencies. NOTE: See Annex I for cell information.
Cell 2			Cell 2 is not included in the monitored set. Cell 2 is located on one of the 2 additional frequencies of the monitored set. NOTE: Cell 2 is included in the monitored cell list (SIB 11), but not known by the UE.
T_{SI}	ms	1280	See Annex I for the SIB repetition period of system information blocks.
Reporting frequency	Seconds	4	
T1	s	10	
T2	s	6	

Table 8.4.1.4 Cell specific parameters for RRC re-establishment delay test, Test 2

Parameter	Unit	Cell 1		Cell 2	
		T1	T2	T1	T2
Cell Frequency	ChNr	1		2	
CPICH_Ec/I _{or}	dB	-10		-10	
PCCPCH_Ec/I _{or}	dB	-12		-12	
SCH_Ec/I _{or}	dB	-12		-12	
PICH_Ec/I _{or}	dB	-15		-15	
DCH_Ec/I _{or}	dB	Note 1	-Infinity	Not applicable	
OCNS_Ec/I _{or}	dB	Note 2	-0.941	-0.941	
\hat{I}_{or}/I_{oc}	dB	-3,35	-Infinity	-Infinity	0,02
I_{oc}	dBm/ 3.84 MHz	-70			
CPICH_Ec/I _o	dB	-15	-Infinity	-Infinity	-13
Propagation Condition		AWGN			
Note 1: The DPCH level is controlled by the power control loop.					
Note 2: The power of the OCNS channel that is added shall make the total power from the cell to be equal to I_{or} .					

8.4.1.2.4.2 Procedure

- 1) The RF parameters are set up according to T1.
- 2) The UE is switched on.
- 3) A call is set up according to the test procedure specified in TS 34.108 [3] subclause 7.3.4 without Compressed mode parameters.
- 4) 10 s after step3 has completed, the parameters are changed to that as described for T2.
- 5) If the UE responds on cell 2 within 4.4 s from the beginning of time period T2 with a CELL_UPDATE command then the number of successful tests is increased by one.
- 6) SS shall transmit a RRC CONNECTION RELEASE message to make the UE transit to idle mode.
- 7) After 6 seconds the RF parameters are set up according to T1.
- 8) The SS shall wait for 30s to make the UE complete cell reselection to cell1.
- 9) Repeat step 3-8 until the confidence level according to annex F.6.2 is achieved.

NOTE 1: The time required for receiving all the relevant system information data according to the reception procedure and the RRC procedure delay of system information blocks is defined in 25.331 for a UTRAN cell. Since the maximum time to read the relevant system info blocks that needs to be received by the UE to camp on a cell is 1420ms (see note 2) and the maximum RRC procedure delay for reception system information block is 100ms, 1520ms is assumed in this test case. Therefore this gives a total of 4360ms (Minimum requirement + 240ms), allow 4.4s in the test case.

NOTE 2: The maximum repetition period of the relevant system info blocks that needs to be received by the UE to camp on a cell is 1280ms. The Master Information Block (MIB) is repeated every 8 frame and SIB5 (and SIB11) is segmented into 4 segments where the first segment is scheduled adjacent to the MIB at SIB_POS=40 and the other three segments are scheduled after the MIB (SIB_POS=42, 44 and 46). The maximum time for a UE to read SIB5 will occur if the UE start reading the BCH at the SFN after the MIB located prior to the first segment of SIB5 (SIB_POS 32). Then the UE will not be able to read SIB5 until the second occurrence of SIB5, which will happen at SIB_POS 46 + 1280ms. This gives that the maximum time for the UE to read the relevant system info will be 1420ms ((SIB_POS 46 – SIB_POS 32)*10ms +1280ms).

All messages indicated above shall use the same content as described in the default message content in clause 9 of 34.108 [3], with the following exceptions:

Contents of RRC CONNECTION RELEASE message UM (Step 6):

Information Element	Value/remark	Version
Release cause	Re-establishment Reject	

8.4.1.2.5 Test requirements

For the test to pass, the total number of successful tests shall be more than 90% of the cases with a confidence level of 95%.

Note: If the above Test Requirement differs from the Minimum Requirement then the Test Tolerance applied for this test is non-zero. The Test Tolerance for this test is defined in clause F.2 and the explanation of how the Minimum Requirement has been relaxed by the Test Tolerance is given in clause F.4.

8.4.2 Random Access

8.4.2.1 Correct behaviour when receiving an ACK (Release 5 and earlier)

8.4.2.1.1 Definition and applicability

The random access procedure is used when establishing the layer 1 communication between the UE and UTRAN. The random access shall provide a fast access but without disturbing ongoing connections. The random access is specified in clause 6 of TS 25.214 [5] and the control of the RACH transmission is specified in clause 11.2 of TS 25.321. A random access transmit sequence is described in clause 6.7.2 of TS 25.303.

This test is applicable for Release 5 and earlier releases only. See subclause 8.4.2.1A for later releases.

8.4.2.1.2 Minimum Requirements

The UE shall have capability to calculate initial power according to the open loop algorithm and apply this power level at the first preamble and increase the power on additional preambles. The absolute power applied to the first preamble shall have an accuracy as specified in table 6.3 of TS 25.101 [1]. The relative power applied to additional preambles shall have an accuracy as specified in clause 6.5.2.1 of 25.101 [1].

The absolute power applied to the first preamble shall be -30 dBm with an accuracy as specified in clause 6.4.1.1 of TS 25.101 [1]. The accuracy is ± 9 dB in the case of normal condition or ± 12 dB in the case of extreme condition.

There are two relative powers, one is the power difference for preamble ramping and another is the power difference between last preamble part and message part. From the test parameter in the table 8.4.2.1.2, the test requirement of the power difference for all preamble ramping is 3dB (Power offset P₀). The accuracy is ± 2 dB as specified in clause 6.5.2.1 of 25.101 [1]. The test requirement of the power difference between 10th preamble PRACH and message part is 3 dB (note). The accuracy is ± 2 dB as specified in clause 6.5.2.1 of 25.101 [1].

NOTE: In order to calculate the power difference between 10th preamble PRACH and message part by using Power offset P_{p-m} in the table 8.4.2.1.2, the gain factors of PRACH message part are needed. The gain factor β_d is set to 15. The temporary gain factor β_c is set to 15.

The UE shall stop transmitting preambles upon a ACK on the AICH has been received and then transmit a message. The UE shall transmit 10 preambles and 1 message.

The normative reference for this requirements is TS 25.133 [2] clauses 6.3.2 and A.6.2.2.1.

8.4.2.1.3 Test purpose

The purpose of this test is to verify that the behaviour of the random access procedure is according to the requirements and that the PRACH power settings are within specified limits.

8.4.2.1.4 Method of test

8.4.2.1.4.1 Initial conditions

Test environment: normal, TL/VL, TL/VH, TH/VL, TH/VH; see clauses G.2.1 and G.2.2.

Frequencies to be tested: mid range; see clause G.2.4.

- 1) Connect the SS to the UE antenna connector as shown in figure A.1 in the case of the PRACH power measurement. And in the case of the function test of the random access procedure, connect the SS to the UE antenna connector as shown in figure A.8. A spectrum analyzer is set to 0 span mode.

See TS 34.108 [3] for details regarding generic call setup procedure.

Table 8.4.2.1.1: RF Parameters for Random Access test

Parameter	Unit	Cell 1
UTRA RF Channel Number		Channel 1
CPICH_Ec/Ior	dB	-10
PCCPCH_Ec/Ior	dB	-12
SCH_Ec/Ior	dB	-12
Number of other transmitted Acquisition Indicators	-	0
AICH_Ec/Ior	dB	-10
PICH_Ec/Ior	dB	-15
OCNS_Ec/Ior when an AI is not transmitted	dB	-0,941
OCNS_Ec/Ior when an AI is transmitted	dB	-1,516
\hat{I}_{or}/I_{oc}	dB	0
I_{oc}	dBm/3.84 MHz	-70
CPICH_Ec/Io	dB	-13
Propagation Condition		AWGN

The test parameters "System Information Block (SIB) type 5 (ASC #0)" defined in clause 6.1 of TS 34.108 [3], shall be used in all random access tests (see note). Crucial parameters for the test requirements are repeated in tables 8.4.2.1.2 and 8.4.2.1.3 and these overrule the parameters defined in SIB type 5.

NOTE: A parameter of AC-to-ASC mapping(AC0-9) in SIB5 of clause 6.1 of TS 34.108 [3] shall be set to 0 in the case of all random access tests. The EFACC of Type A, which is specified in clause 8.3.2.15 of TS 34.108 [3], shall be selected.

Table 8.4.2.1.2: UE parameters for Random Access test

Parameter	Unit	Value
Access Service Class (ASC#0)		
- Persistence value	0..1	1
Maximum number of preamble ramping cycles (M_{max}).		2
Maximum number of preambles in one preamble ramping cycle (Preamble Retrans Max)		12
The backoff time T_{B01} $N_{B01min}=N_{B01max}$	ms #TTI	N/A 10
Power step when no acquisition indicator is received (Power offset P0)	dB	3
Power offset between the last transmitted preamble and the control part of the message (Power offset P _{p-m})	dB	0
Maximum allowed UL TX power	DBm	21

Table 8.4.2.1.3: SS parameters for Random Access test

Parameter	Unit	Value
Primary CPICH DL TX power	dBm	-8
UL interference	dBm	-92
SIR in open loop power control (Constant value)	dB	-10
AICH Power Offset	dB	0

8.4.2.1.4.2 Procedure

- 1) A call is set up according to the Generic call setup procedure. The test parameters are set up according to table 8.4.2.1.1, table 8.4.2.1.2 and table 8.4.2.1.3. The PRACH procedure within the call setup is used for the test. It is necessary that an ACK on the AICH shall be transmitted after 10 preambles have been received by the SS
- 2) Measure the first PRACH preamble output power, the each power difference for preamble ramping and the power difference between 10th preamble PRACH and message part of the UE according to annex B.
- 3) Measure the number of the preamble part and the message part by using a spectrum analyzer.

8.4.2.1.5 Test requirements

The accuracy of the first preamble as specified in clause 6.4.1.1 of TS 25.101 [1] shall not be verified in this test. It is verified under the section 5.4.1, Open loop power control.

There are two relative powers, one is the power difference for preamble ramping and another is the power difference between last preamble part and message part. From the test parameter in the table 8.4.2.1.2, the test requirement of the power difference for all preamble ramping is 3dB (Power offset P₀). The accuracy is ± 3 dB. The test requirement of the power difference between 10th preamble PRACH and message part (control + data) is 3 dB (note). The accuracy is ± 3 dB

**Table 8.4.2.1.4:
Test requirement for power difference**

	Power difference for all preambles	Power difference between 10th preamble PRACH and message part (control+data)
Test requirement	3dB ± 3 dB	3dB ± 3 dB

NOTE: In order to calculate the power difference between 10th preamble PRACH and message part by using Power offset P_{p-m} in the table 8.4.2.1.2, the gain factors of PRACH message part are needed. The gain factor β_d is set to 15. The temporary gain factor β_c is set to 15.

The UE shall stop transmitting preambles upon a ACK on the AICH has been received and then transmit a message. The UE shall transmit 10 preambles and 1 message.

Table 8.4.2.1.5: RF Parameters for Random Access test

Parameter	Unit	Cell 1
UTRA RF Channel Number		Channel 1
CPICH_Ec/lor	dB	-10
PCCPCH_Ec/lor	dB	-12
SCH_Ec/lor	dB	-12
Number of other transmitted Acquisition Indicators	-	0
AICH_Ec/lor	dB	-10
PICH_Ec/lor	dB	-15
OCNS_Ec/lor when an AI is not transmitted	dB	-0,941
OCNS_Ec/lor when an AI is transmitted	dB	-1,516
\hat{I}_{or}/I_{oc}	dB	0
I_{oc}	dBm/3.84 MHz	-70
CPICH_Ec/lo	dB	-13
Propagation Condition		AWGN

NOTE: If the above Test Requirement differs from the Minimum Requirement then the Test Tolerance applied for this test is non-zero. The Test Tolerance for this test is defined in clause F.2 and the explanation of how the Minimum Requirement has been relaxed by the Test Tolerance is given in clause F.4.

8.4.2.1A Correct behaviour when receiving an ACK (Release 6 and later)

8.4.2.1A.1 Definition and applicability

The random access procedure is used when establishing the layer 1 communication between the UE and UTRAN. The random access shall provide a fast access but without disturbing ongoing connections. The random access is specified in clause 6 of TS 25.214 [5] and the control of the RACH transmission is specified in clause 11.2 of TS 25.321. A random access transmit sequence is described in clause 6.7.2 of TS 25.303.

This test is applicable for Release 6 and later releases only. This test includes measurement of PRACH timing. See subclause 8.4.2.1 for the PRACH test for earlier releases that does not include PRACH timing.

8.4.2.1A.2 Minimum Requirements

The UE shall have capability to calculate initial power according to the open loop algorithm and apply this power level at the first preamble and increase the power on additional preambles. The absolute power applied to the first preamble shall have an accuracy as specified in table 6.3 of TS 25.101 [1]. The relative power applied to additional preambles shall have an accuracy as specified in clause 6.5.2.1 of 25.101 [1].

The absolute power applied to the first preamble shall be -30 dBm with an accuracy as specified in clause 6.4.1.1 of TS 25.101 [1]. The accuracy is ± 9 dB in the case of normal condition or ± 12 dB in the case of extreme condition.

There are two relative powers, one is the power difference for preamble ramping and another is the power difference between last preamble part and message part. From the test parameter in the table 8.4.2.1A.2, the test requirement of the power difference for all preamble ramping is 3dB (Power offset P₀). The accuracy is ± 2 dB as specified in clause 6.5.2.1 of 25.101 [1]. The test requirement of the power difference between 10th preamble PRACH and message part is 3 dB (note). The accuracy is ± 2 dB as specified in clause 6.5.2.1 of 25.101 [1].

NOTE: In order to calculate the power difference between 10th preamble PRACH and message part by using Power offset P_{p-m} in the table 8.4.2.1A.2, the gain factors of PRACH message part are needed. The gain factor β_d is set to 15. The temporary gain factor β_c is set to 15.

The UE shall stop transmitting preambles upon an ACK on the AICH has been received and then transmit a message. The UE shall transmit 10 preambles and 1 message.

The UE PRACH burst timing error shall be less than or equal to ± 3.5 Chips. The reference point shall be the expected timing calculated from the UE's reference detected path of the P-CCPCH.

The normative reference for this requirement is TS 25.133 [2] clauses 6.3.2, 7.4.2 and A.6.2.2.1.

8.4.2.1A.3 Test purpose

The purpose of this test is to verify that the behaviour of the random access procedure is according to the requirements and that the PRACH power settings and timing are within specified limits.

8.4.2.1A.4 Method of test

8.4.2.1A.4.1 Initial conditions

Test environment: normal, TL/VL, TL/VH, TH/VL, TH/VH; see clauses G.2.1 and G.2.2.

Frequencies to be tested: mid range; see clause G.2.4.

- 1) Connect the SS to the UE antenna connector as shown in figure A.1 in the case of the PRACH power measurement. And in the case of the function test of the random access procedure, connect the SS to the UE antenna connector as shown in figure A.8.

See TS 34.108 [3] for details regarding generic call setup procedure.

Table 8.4.2.1A.1: RF Parameters for Random Access test

Parameter	Unit	Cell 1
UTRA RF Channel Number		Channel 1
CPICH_Ec/Ior	dB	-10
PCCPCH_Ec/Ior	dB	-12
SCH_Ec/Ior	dB	-12
Number of other transmitted Acquisition Indicators	-	0
AICH_Ec/Ior	dB	-10
PICH_Ec/Ior	dB	-15
OCNS_Ec/Ior when an AI is not transmitted	dB	-0,941
OCNS_Ec/Ior when an AI is transmitted	dB	-1,516
\hat{I}_{or}/I_{oc}	dB	0
I_{oc}	dBm/3.84 MHz	-70
CPICH_Ec/Io	dB	-13
Propagation Condition		AWGN

The test parameters "System Information Block (SIB) type 5 (ASC #0)" defined in clause 6.1 of TS 34.108 [3], shall be used in all random access tests (see note). Crucial parameters for the test requirements are repeated in tables 8.4.2.1A.2 and 8.4.2.1A.3 and these overrule the parameters defined in SIB type 5.

NOTE: A parameter of AC-to-ASC mapping (AC0-9) in SIB5 of clause 6.1 of TS 34.108 [3] shall be set to 0 in the case of all random access tests. The EFACC of Type A, which is specified in clause 8.3.2.15 of TS 34.108 [3], shall be selected.

Table 8.4.2.1A.2: UE parameters for Random Access test

Parameter	Unit	Value
Access Service Class (ASC#0)		
- Persistence value	0..1	1
Maximum number of preamble ramping cycles (M_{max}).		2
Maximum number of preambles in one preamble ramping cycle (Preamble Retrans Max)		12
The backoff time T_{B01} $N_{B01min}=N_{B01max}$	ms #TTI	N/A 10
Power step when no acquisition indicator is received (Power offset P0)	dB	3
Power offset between the last transmitted preamble and the control part of the message (Power offset P _{p-m})	dB	0
Maximum allowed UL TX power	DBm	21

Table 8.4.2.1A.3: SS parameters for Random Access test

Parameter	Unit	Value
Primary CPICH DL TX power	dBm	-8
UL interference	dBm	-92
SIR in open loop power control (Constant value)	dB	-10
AICH Power Offset	dB	0

8.4.2.1A.4.2 Procedure

- 1) A call is set up according to the Generic call setup procedure. The test parameters are set up according to table 8.4.2.1A.1, table 8.4.2.1A.2 and table 8.4.2.1A.3. The PRACH procedure within the call setup is used for the test. It is necessary that an ACK on the AICH shall be transmitted after 10 preambles have been received by the SS
- 2) Measure the first PRACH preamble output power and timing, the each power difference for preamble ramping and the power difference between 10th preamble PRACH and message part of the UE according to annex B.
- 3) Measure the number and timing of the preamble part and the message part by using a spectrum analyzer.

8.4.2.1A.5 Test requirements

The power accuracy of the first preamble as specified in clause 6.4.1.1 of TS 25.101 [1] shall not be verified in this test. It is verified under the section 5.4.1, Open loop power control.

The timing accuracy of all measured PRACH preamble and PRACH message bursts shall be within ± 4 chips of the reference timing for the used access slot for PRACH preambles or slot for PRACH messages. The reference timing shall be the expected timing calculated from the UE's reference detected path of the P-CCPCH.

There are two relative powers, one is the power difference for preamble ramping and another is the power difference between last preamble part and message part. From the test parameter in the table 8.4.2.1A.2, the test requirement of the power difference for all preamble ramping is 3dB (Power offset P0). The accuracy is ± 3 dB. The test requirement of the power difference between 10th preamble PRACH and message part (control + data) is 3 dB (note). The accuracy is ± 3 dB

Table 8.4.2.1A.4:
Test requirement for power difference

	Power difference for all preambles		Power difference between 10th preamble PRACH and message part (control+data)	
Test requirement	3dB	±3 dB	3dB	±3 dB

NOTE: In order to calculate the power difference between 10th preamble PRACH and message part by using Power offset P_{p-m} in the table 8.4.2.1A.2, the gain factors of PRACH message part are needed. The gain factor β_d is set to 15. The temporary gain factor β_c is set to 15.

The UE shall stop transmitting preambles upon an ACK on the AICH has been received and then transmit a message. The UE shall transmit 10 preambles and 1 message.

Table 8.4.2.1A.5: RF Parameters for Random Access test

Parameter	Unit	Cell 1
UTRA RF Channel Number		Channel 1
CPICH_Ec/lor	dB	-10
PCCPCH_Ec/lor	dB	-12
SCH_Ec/lor	dB	-12
Number of other transmitted Acquisition Indicators	-	0
AICH_Ec/lor	dB	-10
PICH_Ec/lor	dB	-15
OCNS_Ec/lor when an AI is not transmitted	dB	-0,941
OCNS_Ec/lor when an AI is transmitted	dB	-1,516
\hat{I}_{or}/I_{oc}	dB	0
I_{oc}	dBm/3.84 MHz	-70
CPICH_Ec/lo	dB	-13
Propagation Condition		AWGN

NOTE: If the above Test Requirement differs from the Minimum Requirement then the Test Tolerance applied for this test is non-zero. The Test Tolerance for this test is defined in clause F.2 and the explanation of how the Minimum Requirement has been relaxed by the Test Tolerance is given in clause F.4.

8.4.2.2 Correct behaviour when receiving an NACK

8.4.2.2.1 Definition and applicability

The random access procedure is used when establishing the layer 1 communication between the UE and UTRAN. The random access shall provide a fast access but without disturbing ongoing connections. The random access is specified in clause 6 of TS 25.214 and the control of the RACH transmission is specified in clause 11.2 of TS 25.321. A random access transmit sequence is described in clause 6.7.2 of TS 25.303.

8.4.2.2.2 Minimum Requirements

The UE shall stop transmitting preambles upon a NACK on the AICH has been received and then repeat the ramping procedure when the back off timer T_{B01} expires.

The UE shall transmit 10 preambles in the first ramping cycle and no transmission shall be done by the UE within 100 ms after the NACK has been transmitted by the SS. Then the UE shall start the second preamble ramping cycle.

The normative reference for this requirements is TS 25.133 [2] clauses 6.3.2 and A.6.2.2.2.

8.4.2.2.3 Test purpose

The purpose of this test is to verify that the behaviour of the random access procedure is according to the requirements.

8.4.2.2.4 Method of test

8.4.2.2.4.1 Initial conditions

Test environment: normal, TL/VL, TL/VH, TH/VL, TH/VH; see clauses G.2.1 and G.2.2.

Frequencies to be tested: mid range; see clause G.2.4.

- 1) Connect the SS to the UE antenna connector as shown in figure A.8. A spectrum analyzer is set to 0 span mode.

See TS 34.108 [3] for details regarding generic call setup procedure.

8.4.2.2.4.2 Procedure

- 1) A call is set up according to the Generic call setup procedure. The test parameters are set up according to table 8.4.2.1.1, table 8.4.2.1.2 and table 8.4.2.1.3. The PRACH procedure within the call setup is used for the test. It is necessary that a NACK on the AICH shall be transmitted after 10 preambles have been received by the SS
- 2) Measure the number of the preamble part and the time delay between 10th preamble in the first ramping cycle and first preamble in the second ramping cycle by using a spectrum analyzer.

8.4.2.2.5 Test requirements

The UE shall stop transmitting preambles upon a NACK on the AICH has been received and then repeat the ramping procedure when the back off timer T_{B01} expires.

The UE shall transmit 10 preambles in the first ramping cycle and no transmission shall be done by the UE within 100 ms after the NACK has been transmitted by the SS. Then the UE shall start the second preamble ramping cycle.

NOTE: If the above Test Requirement differs from the Minimum Requirement then the Test Tolerance applied for this test is non-zero. The Test Tolerance for this test is defined in clause F.2 and the explanation of how the Minimum Requirement has been relaxed by the Test Tolerance is given in clause F.4.

8.4.2.3 Correct behaviour at Time-out

8.4.2.3.1 Definition and applicability

The random access procedure is used when establishing the layer 1 communication between the UE and UTRAN. The random access shall provide a fast access but without disturbing ongoing connections. The random access is specified in clause 6 of TS 25.214 and the control of the RACH transmission is specified in clause 11.2 of TS 25.321. A random access transmit sequence is described in clause 6.7.2 of TS 25.303.

8.4.2.3.2 Minimum Requirements

The UE shall stop transmit preambles when reaching the maximum number of preambles allowed in a cycle. The UE shall then repeat the ramping procedure until the maximum number of preamble ramping cycles are reached. No ACK/NACK shall be sent by SS during this test.

The UE shall transmit 2 preambles cycles, consisting of 12 preambles in each preamble cycle.

The normative reference for this requirements is TS 25.133 [2] clauses 6.3.2 and A.6.2.2.3.

8.4.2.3.3 Test purpose

The purpose of this test is to verify that the behaviour of the random access procedure is according to the requirements.

8.4.2.3.4 Method of test

8.4.2.3.4.1 Initial conditions

Test environment: normal, TL/VL, TL/VH, TH/VL, TH/VH; see clauses G.2.1 and G.2.2.

Frequencies to be tested: mid range; see clause G.2.4.

- 1) Connect the SS to the UE antenna connector as shown in figure A.8. A spectrum analyzer is set to 0 span mode.

See TS 34.108 [3] for details regarding generic call setup procedure.

8.4.2.3.4.2 Procedure

- 1) A call is set up according to the Generic call setup procedure. The test parameters are set up according to table 8.4.2.1.1, table 8.4.2.1.2, and table 8.4.2.1.3. The PRACH procedure within the call setup is used for the test. It is necessary that SS shall transmit no AICH.
- 2) Measure the number of the preamble part by using a spectrum analyzer.

8.4.2.3.5 Test requirements

The UE shall stop transmit preambles when reaching the maximum number of preambles allowed in a cycle. The UE shall then repeat the ramping procedure until the maximum number of preamble ramping cycles are reached. No ACK/NACK shall be sent by SS during this test.

The UE shall transmit 2 preamble cycles, consisting of 12 preambles in each preamble cycle.

NOTE: If the above Test Requirement differs from the Minimum Requirement then the Test Tolerance applied for this test is non-zero. The Test Tolerance for this test is defined in clause F.2 and the explanation of how the Minimum Requirement has been relaxed by the Test Tolerance is given in clause F.4.

8.4.2.4 Correct behaviour when reaching maximum transmit power

8.4.2.4.1 Definition and applicability

The random access procedure is used when establishing the layer 1 communication between the UE and UTRAN. The random access shall provide a fast access but without disturbing ongoing connections. The random access is specified in clause 6 of TS 25.214 [5] and the control of the RACH transmission is specified in clause 11.2 of TS 25.321 [13]. A random access transmit sequence is described in clause 6.7.2 of TS 25.303 [12].

8.4.2.4.2 Minimum Requirements

The UE shall not exceed the maximum allowed UL TX power, which is specified in Table 8.4.2.4.1 and configured by the SS, with more than the accuracy tolerances as defined in section 6.5 of TS 25.133 [2].

Section 6.5 of TS25.133 [2] states that for UE output powers that are outside the range covered by the UE transmitted power measurement the UE output power shall not exceed the Maximum allowed UL TX Power with more than the tolerances specified for the Open loop power control in TS 25.101 [1] section 6.4.1.

No ACK/NACK shall be sent by SS during this test.

8.4.2.4.3 Test purpose

The purpose of this test is to verify that the PRACH power behavior when reaching Maximum allowed UL TX power is correct.

8.4.2.4.4 Method of test

8.4.2.4.4.1 Initial condition

Test environment: normal, TL/VL, TL/VH, TH/VL, TH/VH; see clauses G.2.1 and G.2.2.

Frequencies to be tested: mid range; see clause G.2.4.

- 1) Connect the SS to the UE antenna connector as shown in figure A.1.

See TS 34.108 [3] for details regarding generic call setup procedure.

Table 8.4.2.4.1: UE parameters for correct behaviour when reaching maximum transmit power

Parameter	Unit	Value
Access Service Class (ASC#0)		
- Persistence value	0..1	1
Maximum number of preamble ramping cycles (M_{max}).		2
Maximum number of preambles in one preamble ramping cycle (Preamble Retrans Max)		12
The backoff time T_{B01} $N_{B01min}=N_{B01max}$	ms #TTI	N/A 10
Power step when no acquisition indicator is received (Power offset P0)	dB	3
Power offset between the last transmitted preamble and the control part of the message (Power offset P _{p-m})	dB	0
Maximum allowed UL TX power	dBm	0

8.4.2.4.4.2 Procedure

- 1) A call is set up according to the Generic call setup procedure. The test parameters are set up according to table 8.4.2.1.1, table 8.4.2.4.1 and table 8.4.2.1.3. The PRACH procedure within the call setup is used for the test. It is necessary that SS shall transmit no AICH.
- 2) Set the TX output level of the SS to obtain \hat{I}_{or} at the UE antenna connector. \hat{I}_{or} shall be according to table 8.4.2.1.4.
- 3) Measure all PRACH preamble output power of the UE according to annex B.

8.4.2.4.5 Test requirements

The UE shall not exceed the Maximum allowed UL TX power configured by the SS with more than the tolerance specified in Table 8.4.2.4.2.

Table 8.4.2.4.2: Test requirement for maximum preamble power

	Maximum preamble power	
Test requirement(normal)	0dBm	±10 dB
Test requirement(extreme)	0dBm	±13 dB

NOTE: If the above Test Requirement differs from the Minimum Requirement then the Test Tolerance applied for this test is non-zero. The Test Tolerance for this test is defined in clause F.2 and the explanation of how the Minimum Requirement has been relaxed by the Test Tolerance is given in clause F.4.

8.4.3 Transport format combination selection in UE

8.4.3.1 Interactive or Background, PS, UL: 64 kbps

8.4.3.1.1 Definition and applicability

When the UE estimates that a certain TFC would require more power than the maximum transmit power, it shall limit the usage of transport format combinations for the assigned transport format set, according to the functionality specified in section 11.4 in TS25.321 [13]. This in order to make it possible for the network operator to maximise the coverage. Transport format combination selection is described in section 11.4 of TS 25.321 [13].

The requirements and this test apply to all types of UTRA for the FDD UE for Release 99, Release 4, Release 5 and later releases.

8.4.3.1.2 Minimum requirements

The UE shall continuously evaluate based on the *Elimination*, *Recovery* and *Blocking* criteria defined below, how TFCs on an uplink DPDCH can be used for the purpose of TFC selection. The evaluation shall be performed for every TFC in the TFCS using the estimated UE transmit power of a given TFC. The UE transmit power estimation for a given TFC shall be made using the UE transmitted power measured over the measurement period, defined in 9.1.6.1 of TS 25.133 [2] as one slot, and the gain factors of the corresponding TFC.

The UE shall consider the *Elimination* criterion for a given TFC to be detected if the estimated UE transmit power needed for this TFC is greater than the Maximum UE transmitter power for at least X out of the last Y successive measurement periods immediately preceding evaluation. The MAC in the UE shall consider that the TFC is in Excess-Power state for the purpose of TFC selection.

MAC in the UE shall indicate the available bit rate for each logical channel to upper layers within T_{notify} from the moment the *Elimination* criterion was detected.

The UE shall consider the *Recovery* criterion for a given TFC to be detected if the estimated UE transmit power needed for this TFC has not been greater than the Maximum UE transmitter power for the last Z successive measurement periods immediately preceding evaluation. The MAC in the UE shall consider that the TFC is in Supported state for the purpose of TFC selection.

MAC in the UE shall indicate the available bitrate for each logical channel to upper layers within T_{notify} from the moment the *Recovery* criterion was detected.

The evaluation of the *Elimination* criterion and the *Recovery* criterion shall be performed at least once per radio frame.

The definitions of the parameters X,Y and Z which shall be used when evaluating the *Elimination* and the *Recovery* criteria when no compressed mode patterns are activated are given in Table 8.4.3.1.1.

Table 8.4.3.1.1: X, Y, Z parameters for TFC selection

X	Y	Z
15	30	30

The UE shall consider the *Blocking* criterion for a given TFC to be fulfilled at the latest at the start of the longest uplink TTI after the moment at which the TFC will have been in Excess-Power state for a duration of:

$$(T_{\text{notify}} + T_{\text{modify}} + T_{\text{L1_proc}})$$

where:

T_{notify} equals 15 ms

T_{modify} equals $\text{MAX}(T_{\text{adapt_max}}, T_{\text{TTI}})$

$T_{\text{L1_proc}}$ equals 15 ms

$T_{\text{adapt_max}}$ equals $\text{MAX}(T_{\text{adapt_1}}, T_{\text{adapt_2}}, \dots, T_{\text{adapt_N}})$

N equals the number of logical channels that need to change rate

For Release 99 and Release 4, $T_{\text{adapt_n}}$ equals the time it takes for higher layers to provide data to MAC in a new supported bitrate, for logical channel n. Table 8.4.3.1.2 defines T_{adapt} times for different services. For services where no codec is used T_{adapt} shall be considered to be equal to 0 ms.

Table 8.4.3.1.2: T_{adapt}

Service	T_{adapt} [ms]
UMTS AMR	40
UMTS AMR2	60

For Release 5 and later releases $T_{\text{adapt_n}}$ equals the time it takes for higher layers to provide data to MAC in a new supported bitrate, for logical channel n. For services where no codec is used T_{adapt} shall be considered to be equal to 0 ms. For services where either UMTS_AMR2 or UMTS_AMR_WB is used, T_{adapt} shall be considered to be

equal to the time required to switch from the current codec mode to a new supported codec mode. In that case Tadapt equals 20 ms + 40 ms per codec mode switch. E.g. Tadapt equals 60ms if one codec mode switch is necessary and Tadapt equals 140ms if 3 codec mode switches are necessary.

T_{TTI} equals the longest uplink TTI of the selected TFC (ms).

The Maximum UE transmitter power is defined as follows

Maximum UE transmitter power = MIN(Maximum allowed UL TX Power, UE maximum transmit power)

where

Maximum allowed UL TX Power is set by SS and defined in TS 25.331 [8], and

UE maximum transmit power is defined by the UE power class, and specified in TS 25.101 [1].

The normative reference for these requirements is TS 25.133 [2] clauses 6.4.2 and A.6.4.1.

8.4.3.1.3 Test purpose

The purpose is to verify the UE blocks (stops using) a currently used TFC when the UE output power is not sufficient to support that TFC. The test will verify the general requirement on TFC selection in section 8.4.3.1.2 for a RAB intended for packet data services, i.e. Interactive or Background, PS, UL: 64kbps as defined in TS 34.108 [3].

8.4.3.1.4 Method of test

8.4.3.1.4.1 Initial conditions

Test environment: normal, TL/VL, TL/VH, TH/VL, TH/VH; see clauses G.2.1 and G.2.2.

Frequencies to be tested: mid range; see clause G.2.4.

The test parameters are given in Tables 8.4.3.1.3, 8.4.3.1.4, 8.4.3.1.5 and 8.4.3.1.6 below. The test consists of 2 successive time periods, with a time duration of T1 and T2 respectively.

Details on the UL reference RAB in table 8.4.3.1.3 and 8.4.3.1.4 can be found in TS 34.108 [3] section "Interactive or background / UL:64 DL: 64 kbps / PS RAB + UL:3.4 DL:3.4 kbps SRBs for DCCH".

Table 8.4.3.1.3: UL reference RAB, Interactive or Background

	TFI	64 kbps RAB (20ms TTI)	DCCH 3.4kbps (40ms TTI)
TFS	TF0, bits	0x336	0x148
	TF1, bits	1x336	1x148
	TF2, bits	2x336	N/A
	TF3, bits	3x336	N/A
	TF4, bits	4x336	N/A

Table 8.4.3.1.4: UL TFCI

TFCI	(64 kbps RAB, DCCH)
UL_TFC0	(TF0, TF0)
UL_TFC1	(TF0, TF1)
UL_TFC2	(TF1, TF0)
UL_TFC3	(TF1, TF1)
UL_TFC4	(TF2, TF0)
UL_TFC5	(TF2, TF1)
UL_TFC6	(TF3, TF0)
UL_TFC7	(TF3, TF1)
UL_TFC8	(TF4, TF0)
UL_TFC9	(TF4, TF1)

Table 8.4.3.1.5: General test parameters

Parameter	Unit	Value	Comment
TFCS size		10	
TFCS		UL_TFC0, UL_TFC1, UL_TFC2, UL_TFC3, UL_TFC4, UL_TFC5, UL_TFC6, UL_TFC7, UL_TFC8, UL_TFC9	
Power Control		On	
Active cell		Cell 1	
Maximum allowed UL TX power	dBm	21	
T0	s	10	
T1	s	30	
T2	s	10	
Propagation condition		AWGN	

Table 8.4.3.1.6: Cell specific test parameters

Parameter	Unit	Cell 1		
		T0	T1	T2
UTRA RF Channel Number		Channel 1		
CPICH_Ec/I _{or}	dB	-10		
PCCPCH_Ec/I _{or}	dB	-12		
SCH_Ec/I _{or}	dB	-12		
PICH_Ec/I _{or}	dB	-15		
DPCH_Ec/I _{or}	dB	Note 1		
OCNS_Ec/I _{or}	dB	Note 2		
\hat{I}_{or}/I_{oc}	dB	0		
I_{oc}	dBm/3.84 MHz	-70		
CPICH_Ec/I _o	dB	-13		
Propagation Condition		AWGN		
Note 1: The DPCH level is controlled by the power control loop				
Note 2: The power of the OCNS channel that is added shall make the total power from the cell to be equal to I _{or} .				

The amount of available user data shall be sufficient to allow uplink transmission at the highest bit rate (UL_TFC8 or UL_TFC9) during the entire test and it shall be ensured that the UE is using UL_TFC8 or UL_TFC9 at the end of T1.

8.4.3.1.4.2 Procedure

- 1) The SS activates cell 1 with T0 parameters defined in table 8.4.3.1.6.
- 2) The UE is switched on.
- 3) An RRC connection is set up according to the generic set-up procedure specified in TS 34.108 [3] subclause 7.3.2, using the test procedure to setup a PS call using the parameters defined in tables 8.4.3.1.3, 8.4.3.1.4 and 8.4.3.1.5.
- 4) SS shall transmit a MEASUREMENT CONTROL message.
- 5) For T1=30 secs the SS shall command the UE output power to be between 14 and 15 dB below the UE Maximum allowed UL Tx power (table 8.4.3.1.5).
- 6) The SS shall start sending continuously TPC_cmd=1 to the UE for T2=10 secs (see NOTE).
- 7) The time from the beginning of T2 until the UE blocks (stops using) UL_TFC8 and UL_TFC9 shall be measured by the SS. The UE shall stop using UL_TFC8 and UL_TFC9 within 140 ms from beginning of time period T2. A success is counted, if the UE stops within 140ms. An error is counted otherwise.
- 8) Repeat steps 5-7 until the confidence level according to annex F.6.2 is achieved.

NOTE: This will emulate that UL_TFC8 to UL_TFC9 can not be supported because the UE reaches the maximum UL Tx power and still SS is sending power-up commands. .

Specific Message Contents

All messages indicated above shall use the same content as described in the default message content in clause 9 of 34.108 [3], with the following exceptions:

MEASUREMENT CONTROL message:

Information Element	Value/Remark
Message Type	
UE information elements	
-RRC transaction identifier	0
-Integrity check info	
-message authentication code	SS calculates the value of MAC-I for this message and writes to this IE. The first/leftmost bit of the bit string contains the most significant bit of the MAC-I.
-RRC message sequence number	SS provides the value of this IE, from its internal counter.
Measurement Information elements	
-Measurement Identity	1
-Measurement Command	Modify
-Measurement Reporting Mode	
- Measurement Report Transfer Mode	Acknowledged mode RLC
- Periodical Reporting / Event Trigger Reporting Mode	Periodical reporting
-Additional measurement list	Not Present
-CHOICE Measurement Type	Intra-frequency measurement
-Intra-frequency measurement	
- Intra-frequency measurement objects list	Not Present
-Intra-frequency measurement quantity	
-Filter coefficient	0
-CHOICE mode	FDD
-Measurement quantity	CPICH RSCP
-Intra-frequency reporting quantity	
-Reporting quantities for active set cells	
-Cell synchronisation information reporting indicator	TRUE
-Cell Identity reporting indicator	TRUE
-CHOICE mode	FDD
-CPICH Ec/N0 reporting indicator	TRUE
-CPICH RSCP reporting indicator	TRUE
-Pathloss reporting indicator	FALSE
-Reporting quantities for monitored set cells	
-Cell synchronisation information reporting indicator	FALSE
-Cell Identity reporting indicator	TRUE
-CHOICE mode	FDD
-CPICH Ec/N0 reporting indicator	TRUE
-CPICH RSCP reporting indicator	TRUE
-Pathloss reporting indicator	FALSE
-Reporting quantities for detected set cells	Not Present
-Reporting cell status	
-CHOICE reported cell	Report all active set cells + cells within monitored set on used frequency
-Maximum number of reported cells	Virtual/active set cells + 2
-Measurement validity	Not Present
-CHOICE <i>report criteria</i>	Periodical reporting criteria
-Amount of reporting	Infinity
-Reporting interval	250 ms
Physical channel information elements	
-DPCH compressed mode status info	Not Present

8.4.3.1.5 Test requirements

For the test to pass, the total number of successful tests shall be more than 90% of the cases with a confidence level of 95%.

Note: If the above Test Requirement differs from the Minimum Requirement then the Test Tolerance applied for this test is non-zero. The Test Tolerance for this test is defined in clause F.2 and the explanation of how the Minimum Requirement has been relaxed by the Test Tolerance is given in clause F.4.

8.4.4 E-TFC restriction in UE

8.4.4.1 10ms TTI E-DCH E-TFC restriction

8.4.4.1.1 Definition and applicability

When the UE estimates that a certain TFC and E-TFC would require more power than the maximum transmit power, it shall limit the usage of transport format combinations for the assigned transport format set, according to the functionality specified in section 11.8.1.4 in TS25.321 [13]. This is in order to make it possible for the network operator to maximise the coverage. E-TFC selection is described in section 11.8.1.4 of TS25.321 [13].

The requirements of this test apply to Release 6 and later releases for all types of UTRA for the FDD UE that support E-DCH and HSDPA.

8.4.4.1.2 Minimum requirements

The UE shall continuously evaluate based on the *Elimination*, *Recovery* and *Blocking* criteria defined below, how TFCs on an uplink DPDCH can be used for the purpose of TFC selection. The evaluation shall be performed for every TFC in the TFCS using the estimated UE transmit power.

The UE transmit power estimation for a given TFC, when HS-DPCCH is not transmitted during the measurement period, shall be calculated using the DPDCH and DPCCH gain factors of the corresponding TFC and reference transmit power. The reference transmit power is the transmit power of DPCCH and DPDCH of a given TFC during the measurement period for which UE transmit power estimation is made. If HS-DPCCH is transmitted either partially or totally within the given measurement period the UE transmit power estimation for a given TFC shall be calculated using DPDCH and DPCCH gain factors, the maximum value of the HS-DPCCH gain factor that is used during the measurement period, and the reference transmit power. The timing of the measurement period, which is defined in 9.1.6.1 of TS 25.133 [2] as one slot, is the same as the timing of the DPCH slot.

E-TFC selection is allowed only in the CELL_DCH state. E-TFC selection is based on the estimated power leftover from TFC selection if the DPDCH is present and from the HS-DPCCH.

The UE shall estimate the normalised remaining power margin available for E-TFC selection based on the following equation for E-TFC candidate j

$$NRPM_j = (P_{Max_j} - P_{DPCCH, target} - P_{DPDCH} - P_{HS-DPCCH} - P_{E-DPCCH}) / P_{DPCCH, target}$$

where

P_{Max_j} = Maximum UE transmitter power for E-TFC- j as defined in section 6.5 of TS25.133 [2].

$P_{DPCCH}(t)$ represents a slotwise estimate of the current UE DPCCH power at time t . If at time t , the UE is transmitting a compressed mode frame then $P_{DPCCH,comp}(t) = P_{DPCCH}(t) \times (N_{pilot,C} / N_{pilot,N})$ else $P_{DPCCH,comp}(t) = P_{DPCCH}(t)$. If the UE is not transmitting uplink DPCCH during the slot at time t , either due to compressed mode gaps or when discontinuous uplink DPCCH transmission operation is enabled then the power shall not contribute to the filtered result. Samples of $P_{DPCCH,comp}(t)$ shall be filtered using a filter period of 3 slotwise estimates of $P_{DPCCH,comp}(t)$ when the E-DCH TTI is 2ms or 15 slotwise estimates of $P_{DPCCH,comp}$ when the E-DCH TTI is 10ms to give $P_{DPCCH,filtered}$. The accuracy of the P_{DPCCH} estimate shall be at least that specified in table 8.4.4.1.1.2.

If the target E-DCH TTI for which $NRPM_j$ evaluated does not correspond to a compressed mode frame then $P_{DPCCH,target} = P_{DPCCH,filtered}$.

If the target E-DCH TTI for which $NRPM_j$ is being evaluated corresponds to a compressed mode frame then $P_{DPCCH,target} = P_{DPCCH,filtered} \times (N_{pilot,N} / N_{pilot,C})$. $N_{pilot,N}$ and $N_{pilot,C}$ are numbers of pilot symbols as defined in [5].

P_{DPDCH} = estimated DPDCH transmit power, based on $P_{DPDCH,target}$ and the gain factors from the TFC selection that has already been made. If the target E-DCH TTI for for which $NRPM_j$ is being evaluated corresponds to a compressed mode frame then the modification to the gain factors which occur due to compressed mode shall be included in the estimate of P_{DPDCH}

$P_{HS-DPCCH}$ = estimated HS-DPCCH transmit power based on the maximum HS-DPCCH gain factor based on $P_{DPCCH,target}$ and the most recent signalled values of Δ_{ACK} , Δ_{NACK} and Δ_{CQI} . If the target E-DCH TTI for for which $NRPM_j$ is being evaluated corresponds to a compressed mode frame then the modification to the gain factors which occur due to compressed mode shall be included in the estimate of $P_{HS-DPCCH}$

$P_{E-DPCCH}$ = estimated E-DPCCH transmit power, based on $P_{DPCCH,target}$ and the E-DPCCH gain factor calculated using the most recent signalled value of $\Delta_{E-DPCCH}$. If the target E-DCH TTI for for which $NRPM_j$ is being evaluated corresponds to a compressed mode frame then the modification to the gain factors which occur due to compressed mode shall be included in the estimate of $P_{E-DPCCH}$

Note: $P_{DPCCH}(t)$, P_{Max_j} , $P_{DPCCH,fil,target}$, P_{DPDCH} , $P_{HS-DPCCH}$, and $P_{E-DPCCH}$ are expressed in linear power units

The UE shall consider the *Elimination* criterion for a given TFC to be detected if the estimated UE transmit power needed for this TFC is greater than the Maximum UE transmitter power for at least X out of the last Y successive measurement periods immediately preceding evaluation. The MAC in the UE shall consider that the TFC is in Excess-Power state for the purpose of TFC selection.

MAC in the UE shall indicate the available bitrate for each logical channel to upper layers within T_{notify} from the moment the *Elimination* criterion was detected.

The UE shall consider the *Recovery* criterion for a given TFC to be detected if the estimated UE transmit power needed for this TFC has not been greater than the Maximum UE transmitter power for the last Z successive measurement periods immediately preceding evaluation. The MAC in the UE shall consider that the TFC is in Supported state for the purpose of TFC selection.

MAC in the UE shall indicate the available bitrate for each logical channel to upper layers within T_{notify} from the moment the *Recovery* criterion was detected.

The evaluation of the *Elimination* criterion and the *Recovery* criterion shall be performed at least once per radio frame.

The definitions of the parameters X, Y and Z which shall be used when evaluating the *Elimination* and the *Recovery* criteria when no compressed mode patterns are activated are given in Table 8.4.4.1.1.1.

Table 8.4.4.1.1.1: X, Y, Z parameters for TFC selection

X	Y	Z
15	30	30

The UE shall consider the *Blocking* criterion for a given TFC to be fulfilled at the latest at the start of the longest uplink TTI after the moment at which the TFC will have been in Excess-Power state for a duration of:

$$(T_{notify} + T_{modify} + T_{L1_proc})$$

where:

T_{notify} equals 15 ms, and

T_{modify} equals $\text{MAX}(T_{adapt_max}, T_{TTI})$, and

T_{L1_proc} equals 15 ms, and

T_{adapt_max} equals $\text{MAX}(T_{adapt_1}, T_{adapt_2}, \dots, T_{adapt_N})$, and

N equals the number of logical channels that need to change rate, and

T_{adapt_n} equals the time it takes for higher layers to provide data to MAC in a new supported bitrate, for logical channel n. For services where no codec is used T_{adapt} shall be considered to be equal to 0 ms. For services where either UMTS_AMR2 or UMTS_AMR_WB is used, T_{adapt} shall be considered to be equal to the time required to switch from the current codec mode to a new supported codec mode. In that case T_{adapt} equals 20 ms + 40 ms

per codec mode switch. E.g. Tadapt equals 60ms if one codec mode switch is necessary and Tadapt equals 140ms if 3 codec mode switches are necessary.

T_{TTI} equals the longest uplink TTI of the selected TFC (ms).

The UE shall be able to update the normalised remaining power estimate of each E-TFC at least every E-DCH TTI. The UE shall use the latest available estimate of $NRPM_j$ at the time when all absolute and relative grants relating to the E-DCH TTI under consideration have been received. Using the estimates of $NRPM_j$ the UE shall evaluate for each E-TFC which configured MAC-d flows are supported and which are unsupported as follows:

In the case that the target E-DCH TTI for which E-TFC restriction is being considered does not belong to a compressed mode frame then if $NRPM_j \geq \sum(\beta_{ed,j}/\beta_c)^2$ then E-TFC_j can be supported, otherwise it cannot be supported

In the case that the target E-DCH TTI for which E-TFC restriction is being considered belongs to a compressed mode frame then if $NRPM_j \geq \sum(\beta_{ed,c,j}/\beta_{c,c})^2$ then E-TFC_j can be supported, otherwise it cannot be supported

$\beta_{ed,j}/\beta_c$ and $\beta_{ed,c,j}/\beta_{c,c}$ is the quantized amplitude ratio.

If the UE is allowed to reduce its maximum transmit power for certain TFCs and E-TFCs, the UE shall use the reduced maximum transmit power in the evaluation of the TFC and E-TFC selection criteria for those TFCs.

Table 8.4.4.1.1.2: Accuracy requirements for the estimate of P_{DPCCH} used in E-TFC restriction

Total UE output power value (dBm)	P_{DPCCH} accuracy(dB) (note 1)
25<= total output power <34	note 2
24<= total output power <25	±2.0
23<= total output power <24	±2.0
22<= total output power <23	±2.0
21<= total output power <22	±2.0
20<= total output power < 21	±2.5
19<= total output power <20	±3.0
18<= total output power <19	±3.5
17<= total output power <18	±4.0
16<= total output power <17	±4.0
15<= total output power <16	±4.0
14<= total output power <15	±4.0
13<= total output power <14	±4.0 (power class 4) ±6.0 (power class 3)
12<= total output power <13	±4.0 (power class 4) ±6.0 (power class 3)
11<= total output power <12	±4.0 (power class 4) ±6.0 (power class 3)
-50<= total output power <11	±6.0
Note 1: P_{DPCCH} accuracy is the difference between the estimate of P_{DPCCH} used by the UE for the purposes of E-TFC selection and the actual power of the DPCCH being transmitted	
Note 2: No tolerance is specified.	

The normative reference for these requirements is TS 25.133 [2] clauses 6.4.2 and A.6.6.1.1.

8.4.4.1.3 Test Purpose

The purpose is to verify the UE stops using a currently used E-TFC when its remaining power margin is not sufficient to support that E-TFC, and resumes using that E-TFC when its remaining power margin is sufficient to support it. This test will verify the general requirement on E-TFC selection in section 8.4.4.1.2 for a 10 ms TTI E-DCH Transport Block Size Table 0 as defined in TS 25.321 [13].

The test will verify the general requirement on E-TFC restriction and recovery in section 6.4 of TS25.133 [2] for a 10ms TTI E-DCH Transport Block Size Table 0.

NOTE: The test case covers only the continuous uplink DPCCH transmission scenario.

8.4.4.1.4 Method of test

8.4.4.1.4.1 Initial conditions

Test environment: normal, TL/VL, TL/VH, TH/VL, TH/VH; see clauses G.2.1 and G.2.2.

Frequencies to be tested: mid range; see clause G.2.4.

- 1) Connect the SS (node B emulator) to the UE antenna connector as shown in figure A.1.
- 2) The UL Reference Measurement Channel and the Fixed Reference Channels (FRC H-Set 1, QPSK) are specified in Annex C.11.1 and C.8.1.1.

The test parameters are given in Table 8.4.4.1.3 and 8.4.4.1.6 below. The test consists of 2 time periods, with a time duration of T1 and T2 respectively.

The UE shall be configured to transmit UL DTCH data continuously on the DPCH. An HSDPA radio bearer shall be configured so that the UE transmits ACK on the UL HS-DPCCH. An E-DCH radio bearer shall be configured, so that UE is transmitting E-DPCCH and E-DPDCH in the initial condition before the time T1, defined as T0.

Table 8.4.4.1.3: General test parameters

Parameter	Unit	Value	Comment
UL DPCH configuration		12.2kbps reference measurement channel	
E-DCH Transport Block Size Table		10ms TTI E-DCH Transport Block Size Table 0 according to TS 25.321 [13] annex B.3	
UL Power Control		On	
Active cell		Cell 1	
Maximum allowed UL TX power	dBm	24	For a class 4 UE maximum allowed TX power can still be signalled as 24dBm however the UE only has capability to transmit 21dBm
Propagation condition		AWGN	
β_d/β_c		9/15	Care needs to be taken to ensure that TFCS with $\beta_d/\beta_c = 9/15$ is always used even during power limited part of the test in T2
A_{hs}		2	$\Delta_{ACK}=\Delta_{NACK}=\Delta_{CQI}$
A_{ec}		2	
$\beta_{ed,ref}/\beta_c$		5/15	
L_{ref}		1	
K_{ref}		18	
Δ_{harq}	dB	0	
$PL_{non-max}$		0.52	
E-DCH minimum set E-TFI		0	Makes E-DCH transport block size with index 0 unblockable even in power limited phase
Periodicity for Scheduling Info		Every TTI	Ensures that some data is sent on every TTI even in the power limited phase
E-DCH MAC-D flow maximum number of retransmissions		0	
T1	S	2	
T2	S	2	

Table 8.4.4.1.4: Additional cell specific parameters

Parameter	Unit	Cell 1		
		T0	T1	T2
UTRA RF Channel Number		Channel 1		
P-CPICH E_c/I_{or}		-10		
PCCPCH E_c/I_{or}	dB	-12		
SCH E_c/I_{or}	dB	-12		
PICH E_c/I_{or}	dB	-15		
DPCH E_c/I_{or}	dB	-7.5		
HS-SCCH E_c/I_{or}	dB	-7.5		
HS-PDSCH E_c/I_{or}	dB	-3.67		
E-RGCH E_c/I_{or}	dB	DTX'd		
E-AGCH E_c/I_{or}	dB	-20		
E-HICH E_c/I_{or}	dB	-20		
OCNS E_c/I_{or}	dB	Note 1		
\hat{I}_{or}	dBm/3.84 MHz	-70		
Note 1: The power of the OCNS channel that is added shall make the total power from the cell to be equal to I_{or} .				

The amount of available user data shall be sufficient to allow E-DCH uplink transmission at the highest possible bit rate with E-DCH TB index 127. It shall also be ensured that sufficient data is made available on the DTCH so that the UE is continuously transmitting on the DPCH.

8.4.4.1.4.2 Procedure

- 1) The SS activates cell 1 with T0 parameters defined in table 8.4.4.1.4.
- 2) The UE is switched on.
- 3) An E-DCH call is set up according to TS 34.108 [3] 7.3.9 with the following exceptions in the RADIO BEARER SETUP messages. These exceptions are derived from Table 8.4.4.1.3, and in addition allow the beta values to be set and each UL physical channel to be at constant power during the measurement.
- 4) Enter the UE into loopback mode 1 looping back both the 12.2kbps RMC and HSDPA to E-DCH and start the loopback test. See TS 34.109 [4] clauses 5.3.2.3 and 5.3.2.6. This way the UE is configured to transmit a data stream on the E-DPDCH with E-DPCCH.

Table 8.4.4.1.4A Contents of RADIO BEARER SETUP message: AM or UM (Test Loop Mode1)

Information Element	Value/Remark
UL Transport channel information for all transport channels	
- 2bit CTFC	3
- Power offset Information	
- CHOICE Gain Factors	Signalled Gain Factors
- CHOICE mode	FDD
- Gain factor β_c	15/15
- Gain factor β_d	9/15
Maximum allowed UL TX power	24dBm
Note: All other 2 bit CTFC values use computed gain factors as in the default message	

Table 8.4.4.1.4B Contents of RADIO BEARER SETUP message: AM or UM (E-DCH and HSDPA)

Information Element	Value/Remark
- Added or reconfigured E-DCH MAC-d flow - E-DCH MAC-d flow maximum number of retransmissions	0
Uplink DPCH info - Δ_{ACK} - Δ_{NACK} - Ack-Nack repetition factor	8, giving $A_{hs} = 30/15$ 8, giving $A_{hs} = 30/15$ 3 (required for continuous HS-DPCCH signal)
E-DCH info - E-DPCCH info - E-DPCCH/DPCCH power offset - E-DPDCH info - E-DCH minimum set E-TFCI - Reference E-TFCIs - Reference E-TFCI - Reference E-TFCI PO - Maximum channelisation codes - PLnon-max - Scheduling Information Configuration - Periodicity for Scheduling Info – grant	Uplink DPCH info 8, giving $A_{ec} = 30/15$ 0, making E-DCH transport block size with index 0 unblockable even in power limited phase 1 E-TFCI 0 0, giving $A_{ed} = 5/15$ 2sf4, for E-DPDCH Categories 1, 2 and 3 2sf2, for E-DPDCH Categories 4, 5 and 6 0.52 Every TTI
Downlink HS-PDSCH Information - Measurement Feedback Info - CQI Feedback cycle, k - CQI repetition factor - Δ_{CQI}	4 ms 2 (required for continuous HS-DPCCH signal) 8, giving $A_{hs} = 30/15$

- 5) The Nominal Avg. Information Bit Rate in the DL is set to 534 kbps according to QPSK H-Set 1. The UL RLC PDU size shall be 336 bits. The SS signals AG value = 31 and AG scope = 0 on the E-AGCH continuously to give UE grants to make use of the maximum possible data rate.
- 6) Before T1, the SS shall send continuously TPC_cmd = +1 to the UE. The UE shall be transmitting at its maximum DPCCH power and the UE uplink E-DPCCH shall indicate use of E-TFCI with index 0.
- 7) From the start of T1 the system simulator shall send sufficient consecutive TPC_cmd = -1 to the UE until the DPCCH power is between -2.3dBm and +1dBm for a power class 3 UE, or between -5.3dBm and -2dBm for a power class 4 UE.
- 8) From the start of T1 the E-TFC indicated on the UE uplink E-DPCCH shall be measured by the SS. An “ETFCI recovery success” is counted, if the UE is using the E-TFC index which represents the maximum of the UE’s capabilities as shown in Table 8.4.4.1.5, within 50ms from the start of T1. An ETFCI recovery error is counted otherwise.

Table 8.4.4.1.5: UE’s 10 ms TTI FDD E-DCH

E-DPDCH Category	E-TFCI Index
Category 1	101
Category 2 - 3	119
Category 4 - 6	127

- 9) Before T2, UE P_{DPCCH} power shall be between -2.3dBm and +1dBm for a power class 3 UE, or between -5.3dBm and -2dBm for a power class 4 UE. The UE uplink E-DPCCH shall indicate use of the E-TFCI which represents the maximum of the UE’s capabilities.
- 10) From the start of T2 the system simulator shall send shall send continuously TPC_cmd = +1 to the UE.
- 11) From the start of T2 the E-TFC indicated on the UE uplink E-DPCCH shall be measured by the SS. An “ETFCI restriction success” is counted, if the UE is using E-TFC with index 0, within 50 ms from the start of T2. An ETFCI restriction error is counted otherwise. During this phase the UE may perform DTX of the E-DPDCH in accordance with [5] clause 5.1.2.6.

12) Repeat steps 6-11 until the confidence level according to Annex F.6.2 is achieved.

NOTE: The required headroom to support E-TFC 127 can be calculated using the parameters $L_{ref}=1$, $K_{ref}=18$ and $K_{127}=20000$. This requires $\{(5006) * 3+12\} * 4 = 60120$ bits before rate matching/ARQ based on section 4 of [31]. This can be transmitted on $2xSF/2$ codes, so needs equivalent of $4xSF/4$ codes, giving $L_{127}=4$.

8.4.4.1.5 Test Requirements

For the test to pass, the ETFCI recovery success ratio shall be more than 90%, and also the ETFCI restriction success ratio shall be more than 90%, each with a confidence level of 95%.

Table 8.4.4.1.6: Cell specific test parameters

Parameter	Unit	Cell 1		
		T0	T1	T2
UTRA RF Channel Number		Channel 1		
P-CPICH E_c/I_{or}		-9.9		
PCCPCH E_c/I_{or}	dB	-12		
SCH E_c/I_{or}	dB	-12		
PICH E_c/I_{or}	dB	-15		
DPCH E_c/I_{or}	dB	-7.5		
HS-SCCH E_c/I_{or}	dB	-7.5		
HS-DSCH E_c/I_{or} (Note 2)	dB	-3.7		
E-RGCH E_c/I_{or}	dB	DTX'd		
E-AGCH E_c/I_{or}	dB	-20		
E-HICH E_c/I_{or}	dB	-20		
OCNS E_c/I_{or}	dB	Note 1		
\hat{I}_{or}	dBm/3.84 MHz	-69.3		
Note 1:	The power of the OCNS channel that is added shall make the total power from the cell to be equal to I_{or} .			
Note 2:	E_c/I_{or} value represent the total power of the HS-DSCH channel (which include five codes as required by H-Set 1)			

Note: If the above Test Requirement differs from the Minimum Requirement then the Test Tolerance applied for this test is non-zero. The Test Tolerance for this test is defined in clause F.2 and the explanation of how the Minimum Requirement has been relaxed by the Test Tolerance is given in clause F.4.

8.4.4.2 2ms TTI E-DCH E-TFC restriction

8.4.4.2.1 Definition and applicability

When the UE estimates that a certain TFC and E-TFC would require more power than the maximum transmit power, it shall limit the usage of transport format combinations for the assigned transport format set, according to the functionality specified in section 11.8.1.4 in TS25.321 [13]. This is in order to make it possible for the network operator to maximise the coverage. E-TFC selection is described in section 11.8.1.4 of TS25.321 [13].

The requirements of this test apply to Release 6 and later releases for all types of UTRA for the FDD UE that support E-DCH and HSDPA.

8.4.4.2.2 Minimum requirements

The UE shall continuously evaluate based on the *Elimination*, *Recovery* and *Blocking* criteria defined below, how TFCs on an uplink DPDCH can be used for the purpose of TFC selection. The evaluation shall be performed for every TFC in the TFCS using the estimated UE transmit power.

The UE transmit power estimation for a given TFC, when HS-DPCCH is not transmitted during the measurement period, shall be calculated using the DPDCH and DPCCH gain factors of the corresponding TFC and reference transmit power. The reference transmit power is the transmit power of DPCCH and DPDCH of a given TFC during the

measurement period for which UE transmit power estimation is made. If HS-DPCCH is transmitted either partially or totally within the given measurement period the UE transmit power estimation for a given TFC shall be calculated using DPDCH and DPCCH gain factors, the maximum value of the HS-DPCCH gain factor that is used during the measurement period, and the reference transmit power. The timing of the measurement period, which is defined in 9.1.6.1 of TS 25.133 [2] as one slot, is the same as the timing of the DPCH slot.

E-TFC selection is allowed only in the CELL_DCH state. E-TFC selection is based on the estimated power leftover from TFC selection if the DPDCH is present and from the HS-DPCCH.

The UE shall estimate the normalised remaining power margin available for E-TFC selection based on the following equation for E-TFC candidate j

$$NRPM_j = (P_{Max_j} - P_{DPCCH, target} - P_{DPDCH} - P_{HS-DPCCH} - P_{E-DPCCH}) / P_{DPCCH, target}$$

where

P_{Max_j} = Maximum UE transmitter power for E-TFC-j as defined in section 6.5 of TS25.133 [2].

$P_{DPCCH}(t)$ represents a slotwise estimate of the current UE DPCCH power at time t. If at time t, the UE is transmitting a compressed mode frame then $P_{DPCCH,comp}(t) = P_{DPCCH}(t) \times (N_{pilot,C} / N_{pilot,N})$ else $P_{DPCCH,comp}(t) = P_{DPCCH}(t)$. If the UE is not transmitting uplink DPCCH during the slot at time t, either due to compressed mode gaps or when discontinuous uplink DPCCH transmission operation is enabled then the power shall not contribute to the filtered result. Samples of $P_{DPCCH,comp}(t)$ shall be filtered using a filter period of 3 slotwise estimates of $P_{DPCCH,comp}(t)$ when the E-DCH TTI is 2ms or 15 slotwise estimates of $P_{DPCCH,comp}$ when the E-DCH TTI is 10ms to give $P_{DPCCH,filtered}$. The accuracy of the P_{DPCCH} estimate shall be at least that specified in table 8.4.4.1.1.2.

If the target E-DCH TTI for which $NRPM_j$ evaluated does not correspond to a compressed mode frame then $P_{DPCCH,target} = P_{DPCCH,filtered}$.

If the target E-DCH TTI for which $NRPM_j$ is being evaluated corresponds to a compressed mode frame then $P_{DPCCH,target} = P_{DPCCH,filtered} \times (N_{pilot,N} / N_{pilot,C})$. $N_{pilot,N}$ and $N_{pilot,C}$ are numbers of pilot symbols as defined in [5].

P_{DPDCH} = estimated DPDCH transmit power, based on $P_{DPCCH,target}$ and the gain factors from the TFC selection that has already been made. If the target E-DCH TTI for for which $NRPM_j$ is being evaluated corresponds to a compressed mode frame then the modification to the gain factors which occur due to compressed mode shall be included in the estimate of P_{DPDCH}

$P_{HS-DPCCH}$ = estimated HS-DPCCH transmit power based on the maximum HS-DPCCH gain factor based on $P_{DPCCH,target}$ and the most recent signalled values of Δ_{ACK} , Δ_{NACK} and Δ_{CQI} . If the target E-DCH TTI for for which $NRPM_j$ is being evaluated corresponds to a compressed mode frame then the modification to the gain factors which occur due to compressed mode shall be included in the estimate of $P_{HS-DPCCH}$

$P_{E-DPCCH}$ = estimated E-DPCCH transmit power, based on $P_{DPCCH,target}$ and the E-DPCCH gain factor calculated using the most recent signalled value of $\Delta_{E-DPCCH}$. If the target E-DCH TTI for for which $NRPM_j$ is being evaluated corresponds to a compressed mode frame then the modification to the gain factors which occur due to compressed mode shall be included in the estimate of $P_{E-DPCCH}$

Note: $P_{DPCCH}(t)$, P_{Max_j} , $P_{DPCCH,filtered}$, P_{DPDCH} , $P_{HS-DPCCH}$, and $P_{E-DPCCH}$ are expressed in linear power units

The UE shall consider the *Elimination* criterion for a given TFC to be detected if the estimated UE transmit power needed for this TFC is greater than the Maximum UE transmitter power for at least X out of the last Y successive measurement periods immediately preceding evaluation. The MAC in the UE shall consider that the TFC is in Excess-Power state for the purpose of TFC selection.

MAC in the UE shall indicate the available bitrate for each logical channel to upper layers within T_{notify} from the moment the *Elimination* criterion was detected.

The UE shall consider the *Recovery* criterion for a given TFC to be detected if the estimated UE transmit power needed for this TFC has not been greater than the Maximum UE transmitter power for the last Z successive measurement periods immediately preceding evaluation. The MAC in the UE shall consider that the TFC is in Supported state for the purpose of TFC selection.

MAC in the UE shall indicate the available bitrate for each logical channel to upper layers within T_{notify} from the moment the *Recovery* criterion was detected.

The evaluation of the *Elimination* criterion and the *Recovery* criterion shall be performed at least once per radio frame.

The definitions of the parameters X, Y and Z which shall be used when evaluating the *Elimination* and the *Recovery* criteria when no compressed mode patterns are activated are given in Table 8.4.4.2.2.1.

Table 8.4.4.2.2.1: X, Y, Z parameters for TFC selection

X	Y	Z
15	30	30

The UE shall consider the *Blocking* criterion for a given TFC to be fulfilled at the latest at the start of the longest uplink TTI after the moment at which the TFC will have been in Excess-Power state for a duration of:

$$(T_{\text{notify}} + T_{\text{modify}} + T_{\text{L1_proc}})$$

where:

T_{notify} equals 15 ms, and

T_{modify} equals $\text{MAX}(T_{\text{adapt_max}}, T_{\text{TTI}})$, and

$T_{\text{L1_proc}}$ equals 15 ms, and

$T_{\text{adapt_max}}$ equals $\text{MAX}(T_{\text{adapt_1}}, T_{\text{adapt_2}}, \dots, T_{\text{adapt_N}})$, and

N equals the number of logical channels that need to change rate, and

$T_{\text{adapt_n}}$ equals the time it takes for higher layers to provide data to MAC in a new supported bitrate, for logical channel n. For services where no codec is used T_{adapt} shall be considered to be equal to 0 ms. For services where either UMTS_AMR2 or UMTS_AMR_WB is used, T_{adapt} shall be considered to be equal to the time required to switch from the current codec mode to a new supported codec mode. In that case T_{adapt} equals 20 ms + 40 ms per codec mode switch. E.g. T_{adapt} equals 60ms if one codec mode switch is necessary and T_{adapt} equals 140ms if 3 codec mode switches are necessary.

T_{TTI} equals the longest uplink TTI of the selected TFC (ms).

The UE shall be able to update the normalised remaining power estimate of each E-TFC at least every E-DCH TTI. The UE shall use the latest available estimate of NRPM_j at the time when all absolute and relative grants relating to the E-DCH TTI under consideration have been received. Using the estimates of NRPM_j the UE shall evaluate for each E-TFC which configured MAC-d flows are supported and which are unsupported as follows:

In the case that the target E-DCH TTI for which E-TFC restriction is being considered does not belong to a compressed mode frame then if $\text{NRPM}_j \geq \sum (\beta_{\text{ed},j} / \beta_c)^2$ then E-TFC_j can be supported, otherwise it cannot be supported

In the case that the target E-DCH TTI for which E-TFC restriction is being considered belongs to a compressed mode frame then if $\text{NRPM}_j \geq \sum (\beta_{\text{ed},C,j} / \beta_{c,C})^2$ then E-TFC_j can be supported, otherwise it cannot be supported

$\beta_{\text{ed},j} / \beta_c$ and $\beta_{\text{ed},C,j} / \beta_{c,C}$ is the quantized amplitude ratio.

If the UE is allowed to reduce its maximum transmit power for certain TFCs and E-TFCs, the UE shall use the reduced maximum transmit power in the evaluation of the TFC and E-TFC selection criteria for those TFCs.

Table 8.4.4.2.2: Accuracy requirements for the estimate of P_{DPCCCH} used in E-TFC restriction

Total UE output power value (dBm)	P_{DPCCCH} accuracy(dB) (note 1)
25<= total output power <34	Note 2
24<= total output power <25	±2.0
23<= total output power <24	±2.0
22<= total output power <23	±2.0
21<= total output power <22	±2.0
20<= total output power < 21	±2.5
19<= total output power <20	±3.0
18<= total output power <19	±3.5
17<= total output power <18	±4.0
16<= total output power <17	±4.0
15<= total output power <16	±4.0
14<= total output power <15	±4.0
13<= total output power <14	±4.0 (power class 4) ±6.0 (power class 3)
12<= total output power <13	±4.0 (power class 4) ±6.0 (power class 3)
11<= total output power <12	±4.0 (power class 4) ±6.0 (power class 3)
-50<= total output power <11	±6.0
Note 1:	P_{DPCCCH} accuracy is the difference between the estimate of P_{DPCCCH} used by the UE for the purposes of E-TFC selection and the actual power of the DPCCCH being transmitted
Note 2:	No tolerance is specified.

The normative reference for these requirements is TS 25.133 [2] clauses 6.4.2 and A.6.6.1.2.

8.4.4.2.3 Test Purpose

The purpose is to verify the UE stops using a currently used E-TFC when its remaining power margin is not sufficient to support that E-TFC, and resumes using that E-TFC when its remaining power margin is sufficient to support it. This test will verify the general requirement on E-TFC selection in section 8.4.4.2.2 for a 2 ms TTI E-DCH Transport Block Size Table 0 as defined in TS 25.321 [13].

The test will verify the general requirement on E-TFC restriction and recovery in section 6.4 of TS25.133 [2] for a 2 ms TTI E-DCH Transport Block Size Table 0.

NOTE: The test case covers only the continuous uplink DPCCCH transmission scenario.

8.4.4.2.4 Method of test

8.4.4.2.4.1 Initial conditions

Test environment: normal, TL/VL, TL/VH, TH/VL, TH/VH; see clauses G.2.1 and G.2.2.

Frequencies to be tested: mid range; see clause G.2.4.

- 1) Connect the SS (node B emulator) to the UE antenna connector as shown in figure A.1.
- 2) The UL Reference Measurement Channel and the Fixed Reference Channels (FRC H-Set 1, QPSK) are specified in Annex C.11.1 and C.8.1.1.

The test parameters are given in Table 8.4.4.2.3 and 8.4.4.2.6 below. The test consists of 2 time periods, with a time duration of T1 and T2 respectively.

The UE shall be configured to transmit UL DTCH data continuously on the DPCH. An HSDPA radio bearer shall be configured so that the UE transmits ACK on the UL HS-DPCCH. An E-DCH radio bearer shall be configured, so that UE is transmitting E-DPCCH and E-DPDCH in the initial condition before the time T1, defined as T0.

Table 8.4.4.2.3: General test parameters

Parameter	Unit	Value	Comment
UL DPCH configuration		12.2kbps reference measurement channel	
E-DCH Transport Block Size Table		2ms TTI E-DCH Transport Block Size Table 0 according to 25.321 annex B.1	
UL Power Control		On	
Active cell		Cell 1	
Maximum allowed UL TX power	dBm	24	For a class 4 UE maximum allowed TX power can still be signalled as 24dBm however the UE only has capability to transmit 21dBm
Propagation condition		AWGN	
β_d/β_c		9/15	Care needs to be taken to ensure that TFCS with $\beta_d/\beta_c = 9/15$ is always used even during power limited part of the test in T2
A_{hs}		2	$\Delta_{ACK}=\Delta_{NACK}=\Delta_{CQI}$
A_{ec}		2	
$\beta_{ed,ref}/\beta_c$		5/15	
L_{ref}		1	
K_{ref}		18	
Δ_{harq}	dB	0	
$PL_{non-max}$		0.52	
E-DCH minimum set E-TFI		0	Makes E-DCH transport block size with index 0 unblockable even in power limited phase
Periodicity for Scheduling Info		Every TTI	Ensures that some data is sent on every TTI even in the power limited phase
E-DCH MAC-d flow maximum number of retransmissions		0	
T1	S	2	
T2	S	2	

Table 8.4.4.2.4: Additional cell specific parameters

Parameter	Unit	Cell 1		
		T0	T1	T2
UTRA RF Channel Number		Channel 1		
P-CPICH E_c/I_{or}		-10		
PCCPCH E_c/I_{or}	dB	-12		
SCH E_c/I_{or}	dB	-12		
PICH E_c/I_{or}	dB	-15		
DPCH E_c/I_{or}	dB	-7.5		
HS-SCCH E_c/I_{or}	dB	-7.5		
HS-DSCH E_c/I_{or}	dB	-3.67		
E-RGCH E_c/I_{or}	dB	-DTX'd		
E-AGCH E_c/I_{or}	dB	-20		
E-HICH E_c/I_{or}	dB	-20		
OCNS E_c/I_{or}	dB	Note 1		
\hat{I}_{or}	dBm/3.84 MHz	-70		
Note 1: The power of the OCNS channel that is added shall make the total power from the cell to be equal to I_{or} .				

The amount of available user data shall be sufficient to allow E-DCH uplink transmission at the highest possible bit rate with E-DCH TB index 127. It shall also be ensured that sufficient data is made available on the DTCH so that the UE is continuously transmitting on the DPCH.

8.4.4.2.4.2 Procedure

- 1) The SS activates cell 1 with T0 parameters defined in table 8.4.4.2.4.
- 2) The UE is switched on.
- 3) An E-DCH call is set up according to TS 34.108 [3] 7.3.9 with the following exceptions in the RADIO BEARER SETUP messages. These exceptions are derived from Table 8.4.4.2.3, and in addition allow the beta values to be set and each UL physical channel to be at constant power during the measurement.
- 4) Enter the UE into loopback mode 1 looping back both the 12.2kbps RMC and HSDPA to E-DCH and start the loopback test. See TS 34.109 [4] clauses 5.3.2.3 and 5.3.2.6. This way the UE is configured to transmit a data stream on the E-DPDCH with E-DPCCH.

Table 8.4.4.2.4A Contents of RADIO BEARER SETUP message: AM or UM (Test Loop Mode1)

Information Element	Value/Remark
UL Transport channel information for all transport channels	
- 2bit CTFC	3
- Power offset Information	
- CHOICE Gain Factors	Signalled Gain Factors
- CHOICE mode	FDD
- Gain factor β_c	15/15
- Gain factor β_d	9/15
Maximum allowed UL TX power	24dBm
Note: All other 2 bit CTFC values use computed gain factors as in the default message	

Table 8.4.4.2.4B Contents of RADIO BEARER SETUP message: AM or UM (E-DCH and HSDPA)

Information Element	Value/Remark
Added or Reconfigured TrCH information list - Added or Reconfigured UL TrCH information - CHOICE UL parameters - E-DCH Transmission Time Interval	2 ms
- Added or reconfigured E-DCH MAC-d flow - E-DCH MAC-d flow maximum number of retransmissions	0
Uplink DPCH info - Δ_{ACK} - Δ_{NACK} - Ack-Nack repetition factor	8, giving $A_{hs} = 30/15$ 8, giving $A_{hs} = 30/15$ 3 (required for continuous HS-DPCCH signal)
E-DCH info - E-DPCCH info - E-DPCCH/DPCCH power offset - E-DPDCH info - E-DCH minimum set E-TFCI - Reference E-TFCIs - Reference E-TFCI - Reference E-TFCI PO - Maximum channelisation codes - PLnon-max - Scheduling Information Configuration - Periodicity for Scheduling Info – grant	Uplink DPCH info 8, giving $A_{ec} = 30/15$ 0, making E-DCH transport block size with index 0 unblockable even in power limited phase 1 E-TFCI 0 0, giving $A_{ed} = 5/15$ 2sf4, for E-DPDCH Category 2 2sf2, for E-DPDCH Categories 4 and 6 0.52 [Every TTI] Ensures that some data is sent on every TTI even in the power limited phase
Downlink HS-PDSCH Information - Measurement Feedback Info - CQI Feedback cycle, k - CQI repetition factor - Δ_{CQI}	4 ms 2 (required for continuous HS-DPCCH signal) 8, giving $A_{hs} = 30/15$

- 5) The Nominal Avg. Information Bit Rate in the DL is set to 534 kbps according to QPSK H-Set 1. The UL RLC PDU size = 336 bits. The SS signals AG value = 31 and AG scope = 0 on the E-AGCH continuously to give UE grants to make use of the maximum possible data rate.
- 6) Before T1, the SS shall send continuously TPC_cmd = +1 to the UE. The UE shall be transmitting at its maximum DPCCH power and the UE uplink E-DPCCH shall indicate use of E-TFCI with index 0.
- 7) From the start of T1 the system simulator shall send sufficient consecutive TPC_cmd = -1 to the UE until the DPCCH power is between 0.3 dBm and 3.0 dBm for a power class 3 UE, or between -3.3 dBm and 0 dBm for a power class 4 UE.
- 8) From the start of T1 the E-TFC indicated on the UE uplink E-DPCCH shall be measured by the SS. An “ETFCI recovery success” is counted, if the UE is using the E-TFC index which represents the maximum of the UE’s capabilities as shown in Table 8.4.4.2.5, within 31 ms from the start of T1. An ETFCI recovery error is counted otherwise.

Table 8.4.4.2.5: UE’s 2 ms TTI FDD E-DCH

E-DPDCH Category	E-TFCI Index
Category 2	88
Category 4	108
Category 6	127

- 9) Before T2, UE P_{DPCCH} power shall be between 0.3dBm and +3dBm for a power class 3 UE, or between -3.3dBm and 0dBm for a power class 4 UE. The UE uplink E-DPCCH shall indicate use of the E-TFCI which represents the maximum of the UE’s capabilities.
- 10) From the start of T2 the system simulator shall send shall send continuously TPC_cmd = +1 to the UE.

11) From the start of T2 the E-TFC indicated on the UE uplink E-DPCCH shall be measured by the SS. An “ETFCI restriction success” is counted, if the UE is using E-TFC with index 0, within 31 ms from the start of T2. An ETFCI restriction error is counted otherwise. During this phase the UE may perform DTX of the E-DPDCH in accordance with [5] clause 5.1.2.6.

12) Repeat steps 6-11 until the confidence level according to Annex F.6.2 is achieved.

NOTE: The required headroom to support E-TFC 127 can be calculated using the parameters $L_{\text{ref}}=1$, $K_{\text{ref}}=18$ and $K_{127}=11484$. This requires $\{(3836) * 3+12\} * 4 = 34560$ bits before rate matching/ARQ based on section 4 of [31]. This can be transmitted on $2xSF/2$ codes, so needs equivalent of $4xSF/4$ codes, giving $L_{127}=4$.

8.4.4.2.5 Test Requirements

For the test to pass, the ETFCI recovery success ratio shall be more than 90%, and also the ETFCI restriction success ratio shall be more than 90%, each with a confidence level of 95%.

Table 8.4.4.2.6: Additional cell specific test parameters

Parameter	Unit	Cell 1		
		T0	T1	T2
UTRA RF Channel Number		Channel 1		
P-CPICH E_c/I_{or}		-9.9		
PCCPCH E_c/I_{or}	dB	-12		
SCH E_c/I_{or}	dB	-12		
PICH E_c/I_{or}	dB	-15		
DPCH E_c/I_{or}	dB	-7.5		
HS-SCCH E_c/I_{or}	dB	-7.5		
HS-DSCH E_c/I_{or} (Note 2)	dB	-3.7		
E-RGCH E_c/I_{or}	dB	-DTX'd		
E-AGCH E_c/I_{or}	dB	-20		
E-HICH E_c/I_{or}	dB	-20		
OCNS E_c/I_{or}	dB	Note 1		
\hat{I}_{or}	dBm/3.84 MHz	-69.3		
Note 1:	The power of the OCNS channel that is added shall make the total power from the cell to be equal to I_{or} .			
Note 2:	E_c/I_{or} value represent the total power of the HS-DSCH channel (which include five codes as required by H-Set 1)			

Note: If the above Test Requirement differs from the Minimum Requirement then the Test Tolerance applied for this test is non-zero. The Test Tolerance for this test is defined in clause F.2 and the explanation of how the Minimum Requirement has been relaxed by the Test Tolerance is given in clause F.4.

8.5 Timing and Signalling Characteristics

8.5.1 UE Transmit Timing

8.5.1.1 Definition and applicability

The UE transmit timing is defined as the timing of the uplink DPCCH/DPDCH frame relative to the first detected path (in time) of the corresponding downlink DPCCH/DPDCH frame from the reference cell. The reference point is the antenna connector of the UE.

The requirements and this test apply to all types of UTRA of the FDD UE.

8.5.1.2 Minimum requirements

The UE initial transmission timing error shall be less than or equal to ± 1.5 chips. This requirement applies at the first transmission on the DPCCH/DPDCH. The reference point for the UE initial transmit timing control requirement shall be the time when the first detected path (in time) of the corresponding downlink DPCCH/DPDCH or F-DPCH frame is received from the reference cell plus T_0 chips. T_0 is defined in TS25.211 [19].

When the UE is not in soft handover, the reference cell shall be the one the UE has in the active set. In case the UE is initially allocated in soft handover, the reference cell shall be the same cell as used for calculating the initial CFN as defined in 25.331 [8].

The cell, which is selected as a reference cell, shall remain as a reference cell even if other cells are added to the active set. In case that the reference cell is removed from the active set the UE shall start adjusting its transmit timing no later than the time when the whole active set update message is available at the UE taking the RRC procedure delay into account.

When the UE has performed a timing-maintained intra- or inter-frequency hard handover and higher layers has indicated that the UE shall not perform any synchronisation procedure for timing maintained intra- or inter-frequency hard handover, or when the UE attempts to re establish all dedicated physical channel(s) after an inter-RAT, intra- or inter-frequency hard-handover failure [18], it shall resume UL transmission with the same transmit timing as used immediately before the handover attempt. After resuming transmission, transmit timing adjustment requirements defined in the remainder of this clause apply.

The UE shall be capable of changing the transmission timing according to the received downlink DPCCH/DPDCH or F-DPCH frame. When the transmission timing error between the UE and the reference cell exceeds ± 1.5 chips the UE is required to adjust its timing to within ± 1.5 chips.

All adjustments made to the UE timing shall follow these rules:

- 1) The maximum amount of the timing change in one adjustment shall be $\frac{1}{4}$ chip.
- 2) The minimum adjustment rate shall be 233ns per second.
- 3) The maximum adjustment rate shall be $\frac{1}{4}$ chip per 200 ms.

In particular, within any given $800 \cdot d$ ms period, the UE transmit timing shall not change in excess of $\pm d$ chip from the timing at the beginning of this $800 \cdot d$ ms period, where $0 \leq d \leq 1/4$.

The normative reference for this requirement is TS 25.133 [2] clause 7.1.2.

- Note 1: The requirement to test that the start of adjustment occurs no later than the RRC procedure delay after the cell update message is not to be tested.
- Note 2: The understanding of the period $800 \cdot d$ is that this is the period between any two timing adjustments. Since d is not defined it is only possible to test against this requirement using the maximum value of $d = \frac{1}{4}$. This defines a minimum period of 200ms over which the maximum adjustment rate of $\frac{1}{4}$ chip per 200ms can fairly be evaluated.
- Note 3: Due to the fact that the UE can update its timing at any interval, including just less than 200ms, when evaluating the maximum adjustment rate in any 200ms period an additional $\frac{1}{4}$ chip quantization uncertainty must be allowed for since there exists the possibility of two timing adjustments during the evaluation period.
- Note 4: The minimum adjustment rate of 233ns/s is only to be evaluated from the end of the RRC procedure delay until the UE has converged on the new reference cell.
- Note 5: In addition to the minimum requirements above, an additional allowance is made to the maximum and minimum adjustment rates of 0.384 chips / s and -0.384 chips/s respectively for the possibility of up to a 0.1 PPM frequency error between the UE and the test system.

8.5.1.3 Test purpose

The purpose of this test is to:

- 1) Verify that the UE initial transmit timing accuracy is within the limits specified in 8.5.1.5.

- 2) Verify that the UE transmit timing accuracy remains within the limits specified in 8.5.1.5 when the timing of a cell in the active set not used as the reference cell changes its timing.
- 3) After receipt of the ACTIVESET UPDATE message, verify that the maximum amount of timing change in one adjustment, and the minimum and maximum adjustment rate are within the limits specified in 8.5.1.5.
- 4) Verify that after convergence on the new reference cell the UE is within the limits specified in 8.5.1.5.

8.5.1.4 Method of test

8.5.1.4.1 Initial conditions

Test environment: normal; see clauses G.2.1 and G.2.2.

Frequencies to be tested: mid range; see clause G.2.4.

For this test, two cells on the same frequency are used.

The reporting of event 1A and event 1B is configured with SIB 11.

- 1) Connect the test system to the UE antenna connector as shown in figure A.14.

Table 8.5.1.1: Test parameters for UE Transmit Timing requirements

Parameter	Unit	Level
DPCH_Ec/lor, Cell 1 and Cell 2	dB	-13.5
CPICH_Ec/lor, Cell 1 and Cell 2	dB	-10
PCCPH_Ec/lor, Cell 1 and Cell 2	dB	-12
SCH_Ec/lor, Cell 1 and Cell 2	dB	-12
PICH_Ec/lor, Cell 1 and Cell 2	dB	-15
OCNS_Ec/lor, Cell 1 and Cell 2	dB	-1.2
I _{or} , Cell 1	dBm/3.84 MHz	-96
I _{or} , Cell 2	dBm/3.84 MHz	-99
Information data rate	kbps	12.2
Relative delay of path received from cell 2 with respect to cell 1	μs	+/-2
Propagation condition	AWGN	

8.5.1.4.2 Procedure

1. A call is set up with Cell 1 according to the Generic call setup procedure specified in TS 34.108 [3] subclause 7.3.4 without Compressed mode. The test parameters are set up according to table 8.5.1.2.
2. After a connection is set up with cell 1, the test system shall measure the UE transmit timing offset with respect to the first detected path (in time) of the downlink DPCCH/DPDCH of cell 1.
3. Cell 2 is introduced into the test system at a delay of +2 μs (7.68 chips) from cell 1. The UE shall transmit a Measurement report message triggered by event 1A. The test system transmits an ACTIVESET UPDATE message (Radio link addition information).
4. The test system transmits a Measurement Control message. The test system verifies that cell 2 is added to the active set.
5. The test system shall measure the UE transmit timing error with respect to the first detected path (in time) of the downlink DPCCH/DPDCH of cell 1.
6. The test system switches the Tx timing of cell 2 to a delay of -2 μs with respect to cell 1. During this step the UE may lose the knowledge of the timing of cell 2. It is assumed that the UE regains knowledge of cell 2 timing prior to step 11.
7. After 2 seconds the test system verifies that cell 2 remains in the active set. The SS then sends a Measurement Control message (measurement release for measurement ID 2).
8. The test system shall measure the UE transmit timing error with respect to the first detected path (in time) of the downlink DPCCH/DPDCH of cell 1.

9. The test system switches off cell 1.
10. Void
11. The UE shall transmit a Measurement report message triggered by event 1B, and the test system shall transmit an ACTIVESET UPDATE message (Radio link removal information). The test system samples the UE Transmit Timing once per frame, beginning immediately after the last TTI, containing the ACTIVESET UPDATE. The samples are named $TrTm(t)$ **Transmit Timing** (discrete time) starting at $t=0$. This instant shall be designated $t=RRC_start$. The instant taken 60 ms later (the maximum allowed RRC procedure delay) shall be designated $t=RRC_end$. The sampling of timing shall continue until $t > RRC_end + 1800$. (The furthest the UE has to adjust is 8.68 chips @ $(1/4/0.28 - 0.384)$ chips / s = 17.1 seconds.)
12. After step 11 has completed, the test system shall, after a delay of 2 seconds, measure the UE transmit timing offset with respect to the first detected path (in time) of the downlink DPCCH/DPDCH of the new reference cell.
13. The test system turns on cell 1 again with the same timing as used in step 1 of the procedure. The UE shall transmit a Measurement report message triggered by event 1A. The test system shall transmit an ACTIVESET UPDATE message (Radio link addition information).
14. The test system transmits a Measurement Control message. The test system verifies that cell 1 is added to the active set. SS then sends a Measurement Control message (measurement release for measurement ID 2).
15. Test system measures the UE transmit timing with respect to the first detected path (in time) of the downlink DPCCH/DPDCH of cell 2.
16. Test system switches off cell 2 and starts sampling the UE Transmit Timing error relative to cell 2 at a rate of once per frame. starting at $t=0$.
17. Void.
18. Step 11 is repeated.
19. Step 12 is repeated.

MEASUREMENT CONTROL message

Information Element	Value/Remark
Message Type	
UE information elements -RRC transaction identifier -Integrity check info -message authentication code -RRC message sequence number	0 SS calculates the value of MAC-I for this message and writes to this IE. The first/ leftmost bit of the bit string contains the most significant bit of the MAC-I. SS provides the value of this IE, from its internal counter.
Measurement Information elements -Measurement Identity -Measurement Command -Measurement Reporting Mode - Measurement Report Transfer Mode - Periodical Reporting / Event Trigger Reporting Mode -Additional measurement list -CHOICE Measurement Type -Intra-frequency measurement - Intra-frequency measurement objects list -Intra-frequency cell info list -Intra-frequency measurement quantity -Filter coefficient -CHOICE mode -Measurement quantity -Intra-frequency reporting quantity -Reporting quantities for active set cells -Cell synchronisation information reporting indicator -Cell Identity reporting indicator -CHOICE mode -CPICH Ec/N0 reporting indicator -CPICH RSCP reporting indicator -Pathloss reporting indicator -Reporting quantities for monitored set cells -Cell synchronisation information reporting indicator -Cell Identity reporting indicator -CHOICE mode -CPICH Ec/N0 reporting indicator -CPICH RSCP reporting indicator -Pathloss reporting indicator -Reporting quantities for detected set cells -Reporting cell status -CHOICE reported cell -Maximum number of reported cells -Measurement validity -CHOICE report criteria -Amount of reporting -Reporting interval	2 Setup Acknowledged mode RLC Periodical reporting Not Present Intra-frequency measurement Not Present 0 FDD CPICH RSCP TRUE TRUE FDD TRUE TRUE FALSE FALSE FALSE FDD FALSE FALSE FALSE Not Present Report all active set cells + cells within monitored set on used frequency Virtual/active set cells + 2 Not Present Periodical reporting criteria Infinity 250 ms
Physical channel information elements -DPCH compressed mode status info	Not Present

ACTIVESET UPDATE message (Radio link addition information)

Information Element/Group name	Value/Remark	Version
Message Type (10.2.17)		
UE information elements - RRC transaction identifier - Integrity check info - message authentication code - RRC message sequence number - Activation time - New U-RNTI	0 SS calculates the value of MAC-I for this message and writes to this IE. The first/ leftmost bit of the bit string contains the most significant bit of the MAC-I. SS provides the value of this IE, from its internal counter. "now". Not Present	
CN information elements - CN Information info	Not Present	
Phy CH information elements Uplink radio resources - Maximum allowed UL TX power	33 dBm	
Downlink radio resources - Radio link addition information - Radio link addition information - Primary CPICH info - Primary scrambling code - Downlink DPCH info for each RL	1 Same as adding cell	
- CHOICE mode - Primary CPICH usage for channel estimation - DPCH frame offset - Secondary CPICH info	FDD Primary CPICH may be used This should be reflected by the IE" Cell synchronisation information" in received MEASUREMENT REPORT message Not Present	
- DL channelisation code - Secondary scrambling code - Spreading factor - Code number - Scrambling code change - TPC combination index - SSDT Cell Identity - Closed loop timing adjustment mode - TFCI combining indicator - SCCPCH Information for FACH - Radio link removal information - TX Diversity Mode	Not Present 128 96 No code change 0 Not Present Not Present FALSE Not Present Not Present Not Present	R99 and Rel-4 only
- SSDT information	Not Present	R99 and Rel-4 only

ACTIVESET UPDATE message (Radio link removal information)

Information Element/Group name	Value/Remark	Version
Message Type (10.2.17)		
UE information elements		
- RRC transaction identifier	0	
- Integrity check info		
-message authentication code	SS calculates the value of MAC-I for this message and writes to this IE. The first/ leftmost bit of the bit string contains the most significant bit of the MAC-I.	
-RRC message sequence number	SS provides the value of this IE, from its internal counter.	
- Activation time	"now".	
- New U-RNTI	Not Present	
CN information elements		
- CN Information info	Not Present	
Phy CH information elements		
Uplink radio resources		
- Maximum allowed UL TX power	33 dBm	
Downlink radio resources		
- Radio link addition information	Not Present	
- Radio link removal information	1	
- Primary CPICH info		
- Primary scrambling code	Same as removing cell	
- TX Diversity Mode	Not Present	
- SSDT information	Not Present	R99 and Rel-4 only

Measurement Control message (measurement release)

Information Element/Group name	Value/Remark
Message Type (10.2.17)	
UE information elements	
- RRC transaction identifier	0
- Integrity check info	
-message authentication code	SS calculates the value of MAC-I for this message and writes to this IE. The first/ leftmost bit of the bit string contains the most significant bit of the MAC-I.
-RRC message sequence number	SS provides the value of this IE, from its internal counter.
Measurement Information elements	
-Measurement Identity	2
-Measurement Command	release

8.5.1.5 Test requirements

Table 8.5.1.2: Test parameters for UE Transmit Timing requirements

Parameter	Unit	Level
DPCH_Ec/ Ior, Cell 1 and Cell 2	dB	-13.4
CPICH_Ec/ Ior, Cell 1 and Cell 2	dB	-9.9
PCCPH_Ec/ Ior, Cell 1 and Cell 2	dB	-12
SCH_Ec/ Ior, Cell 1 and Cell 2	dB	-12
PICH_Ec/ Ior, Cell 1 and Cell 2	dB	-15
OCNS_Ec/ Ior, Cell 1 and Cell 2	dB	-1.21
I _{or} , Cell 1	dBm/3.84 MHz	-95
I _{or} , Cell 2	dBm/3.84 MHz	-97.7
Information data rate	kbps	12.2
Relative delay of path received from cell 2 with respect to cell 1	μs	+/-2
Propagation condition	AWGN	

The following measurement uncertainties have been taken into account in the test requirements below:

The accuracy of transmit timing measurements relative to the reference cell = ± 0.5 chips

The accuracy of the difference between two transmit timing measurements = ± 0.25 chips¹⁾ In steps 2, 5 and 8, the UE transmit timing offset shall be within $T_0 \pm 2.0$ chips with respect to the first detected path (in time) of the downlink DPCCH/DPDCH of cell 1.

- 2) In step 11, check for all adjacent samples that the maximum adjustment step of $\frac{1}{4}$ chip adjusted for measurement uncertainty is met:

From $t=1$ until the end of the measurement record, $|\text{TrTm}(t) - \text{TrTm}(t-1)|$ shall be $\leq (\frac{1}{4} + 0.25)$ chips.

Check for the short term maximum allowed adjustment rate of $\frac{1}{4}$ chip in 200 ms adjusted for quantization uncertainty, frequency drift and measurement uncertainty, using a sliding window of step size 10ms:

From $t=20$ until the end of the measurement record, $|\text{TrTm}(t) - \text{TrTm}(t-20)|$ shall be $\leq (\frac{1}{4} + \frac{1}{4} + 0.384/5 + 0.25)$ chips.

Check for the long term maximum allowed adjustment rate of $\frac{1}{4}$ chip in 200 ms adjusted for frequency drift, quantization uncertainty and measurement uncertainty:

From $t=\text{RRC_end}+21$ until the end of the measurement record, $|\text{TrTm}(t) - \text{TrTm}(\text{RRC_end})|$ shall be $\leq ((t-\text{RRC_end})/20 * (\frac{1}{4} + 0.384/5) + \frac{1}{4} + 0.25)$ chips.

Check for convergence then for the long term minimum allowed adjustment rate of 233 ns/s ($\frac{1}{4}$ chip in 280 ms) adjusted for frequency drift, quantization uncertainty and measurement uncertainty:

For $|\text{TrTm}(t)| < 5.68$ chips, the UE is regarded as still adjusting.

For $|\text{TrTm}(t)| \geq 5.68$ chips, the UE is regarded as converged.

For the last transition from adjusting to converged:

$|\text{TrTm}(t) - \text{TrTm}(\text{RRC_end})|$ shall be $\geq ((t-\text{RRC_end})/28 * (\frac{1}{4} - 0.384*0.28) - \frac{1}{4} - 0.25)$ chips.

Check that final timing is within ± 1.5 chips ± 0.5 chip measurement uncertainty of the timing of the new reference cell

For $t=1750$ to $t=1800$, $5.68 < |\text{TrTm}(t)| < 9.68$

- 3) In step 12. and 15, the UE transmit timing error shall be within $T_0 \pm 2.0$ chips with respect to the first detected path (in time) of the downlink DPCCH/DPDCH of cell 2.
- 4) In step 18, Repeat test requirement step 2 for the second set of TrTm (t) data.
- 5) In step 19., UE transmit timing offset shall be within $T_0 \pm 2.0$ chips with respect to the first detected path (in time) of the downlink DPCCH/DPDCH of cell 1.

NOTE 1: The above Test Requirement differs from the Test Requirement of TS 25.133 [2] clause A7.1.2, from which the requirements for the test system are subtracted to give the above Test Requirement.

NOTE 2: If the above Test Requirement differs from the Minimum Requirement then the Test Tolerance applied for this test is non-zero. The Test Tolerance for this test is defined in clause F.2 and the explanation of how the Minimum Requirement has been relaxed by the Test Tolerance is given in clause F.4.

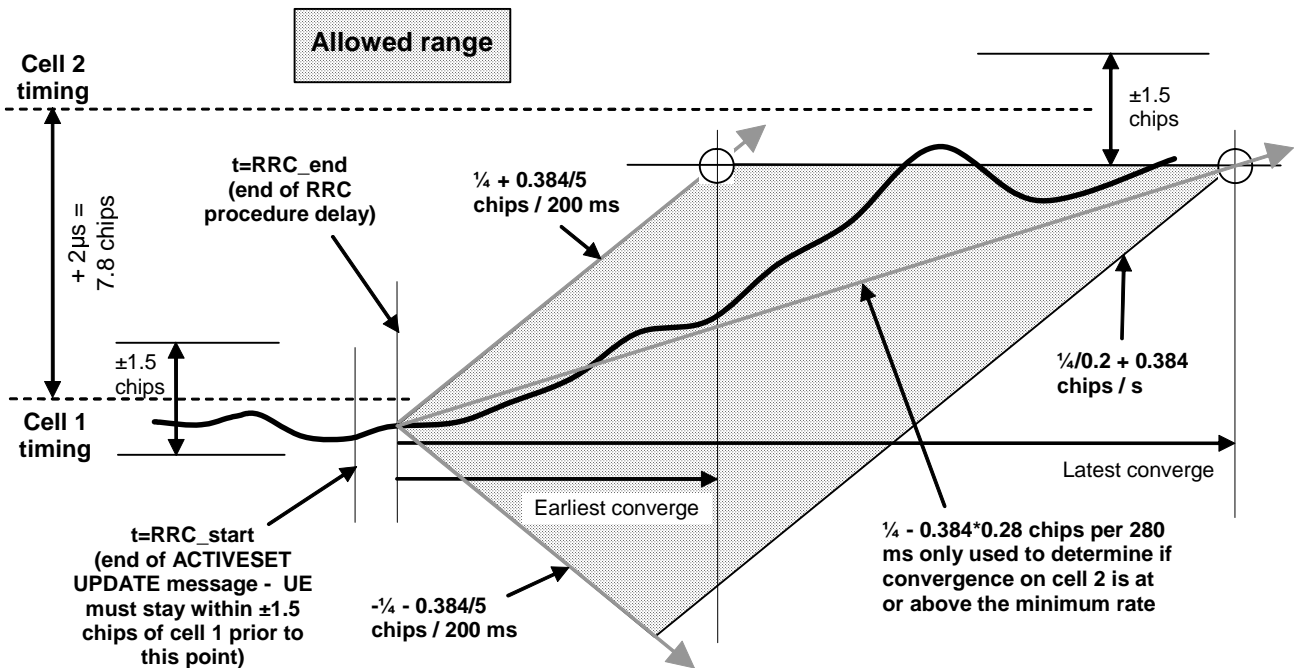

Figure 8.5.1.5 Illustration of measurement principle (excluding measurement uncertainty)

8.6 UE Measurements Procedures

8.6.1 FDD intra frequency measurements

8.6.1.1 Event triggered reporting in AWGN propagation conditions (R99)

8.6.1.1.1 Definition and applicability

In the event triggered reporting period the measurement reporting delay is defined as the time between any event that will trigger a measurement report until the UE starts to transmit over the Uu interface. This requirement assumes that the measurement report is not delayed by other RRC signalling on the DCCH. This measurement reporting delay excludes a delay uncertainty resulted when inserting the measurement report to the TTI of the uplink DCCH. The delay uncertainty is twice the TTI of the uplink DCCH.

The requirements and this test apply to the Release 99 FDD UE.

8.6.1.1.2 Minimum requirements

The UE shall be able to identify and decode the SFN of a new detectable cell belonging to the monitored set within

$$T_{\text{identify intra}} = \text{Max} \left\{ 800, T_{\text{basic identify FDD, intra}} \cdot \frac{T_{\text{Measurement Period, Intra}}}{T_{\text{Intra}}} \right\} \text{ms}$$

A cell shall be considered detectable when CPICH Ec/Io ≥ -20 dB, SCH_Ec/Io ≥ -20 dB for at least one channel tap and SCH_Ec/Io is equally divided between primary synchronisation code and secondary synchronisation code. When L3 filtering is used an additional delay can be expected.

In case of conflict when a compressed gap sequence is activated the UE may choose to prioritise the SFN decoding. In the CELL_DCH state the measurement period for intra frequency measurements is 200 ms. When no transmission gap pattern sequence is activated, the UE shall be capable of performing CPICH measurements for 8 identified intra-frequency cells of the monitored set and/or the active set, and the UE physical layer shall be capable of reporting measurements to higher layers with the measurement period of 200 ms. When one or more transmission gap pattern sequences are activated, the UE shall be capable of performing CPICH measurements for at least Y_{measurement intra} cells, where Y_{measurement intra} is defined in the following equation. The measurement accuracy for all measured cells shall be as specified in the sub-clause 9.1.1 and 9.1.2 of TS 25.133 [2]. If the UE has identified more than Y_{measurement intra} cells, the

UE shall perform measurements of all identified cells but the reporting rate of CPICH measurements of cells from UE physical layer to higher layers may be decreased.

$$Y_{\text{measurement intra}} = \text{Floor} \left\{ X_{\text{basic measurement FDD}} \cdot \frac{T_{\text{Intra}}}{T_{\text{Measurement Period, Intra}}} \right\} \text{ cells}$$

where

$X_{\text{basic measurement FDD}} = 8$ (cells)

$T_{\text{Measurement_Period Intra}} = 200$ ms. The measurement period for Intra frequency CPICH measurements.

T_{Intra} : This is the minimum time that is available for intra frequency measurements, during the measurement period with an arbitrarily chosen timing.

$T_{\text{basic_identify_FDD, intra}} = 800$ ms. This is the time period used in the intra frequency equation where the maximum allowed time for the UE to identify a new FDD cell is defined.

Reported measurements contained in event triggered measurement reports shall meet the requirements in section 9 of TS 25.133 [2].

The UE shall not send event triggered measurement reports, as long as the reporting criteria are not fulfilled.

The measurement reporting delay is defined as the time between any event that will trigger a measurement report until the UE starts to transmit over the Uu interface. This requirement assumes that the measurement report is not delayed by other RRC signalling on the DCCH. This measurement reporting delay excludes a delay uncertainty resulted when inserting the measurement report to the TTI of the uplink DCCH. The delay uncertainty is twice the TTI of the uplink DCCH.

The event triggered measurement reporting delay, on cells belonging to monitored set, measured without L3 filtering, shall be less than the above defined $T_{\text{identify intra}}$ defined above.

If a cell, belonging to monitored set, which the UE has identified and measured at least once over the measurement period, becomes undetectable for a period < 5 seconds and then the cell becomes detectable again and triggers an event, the measurement reporting delay shall be less than $T_{\text{Measurement_Period Intra}}$ ms provided the timing to that cell has not changed more than +/-32 chips, the UE CPICH measurement capabilities defined above are valid and L3 filtering has not been used. When L3 filtering is used an additional delay can be expected.

If a cell belonging to monitored set has been detectable at least for the time period $T_{\text{identify intra}}$ and then enters or leaves the reporting range, the event triggered measurement reporting delay shall be less than $T_{\text{Measurement_Period Intra}}$ when the L3 filter has not been used and the UE CPICH measurement capabilities defined above are valid.

The normative reference for these requirements is TS 25.133 [2] clauses 8.1.2.2 and A.8.1.1.

8.6.1.1.3 Test purpose

To verify that the UE meets the minimum requirements.

8.6.1.1.4 Method of test

8.6.1.1.4.1 Initial conditions

Test environment: normal; see clauses G.2.1 and G.2.2.

Frequencies to be tested: mid range; see clause G.2.4.

The test parameters are given in tables 8.6.1.1.1 to 8.6.1.1.3 below. In the measurement control information it is indicated to the UE that event-triggered reporting with Event 1A and 1B shall be used and that CPICH Ec/Io and SFN-CFN observed time difference shall be reported together with Event 1A.. The test consists of four successive time periods, with a time duration of T1, T2, T3 and T4 respectively. During time duration T1, the UE shall not have any timing information of cell 2.

Table 8.6.1.1.1: General test parameters for Event triggered reporting in AWGN propagation conditions

Parameter	Unit	Value	Comment
DCH parameters		DL and UL Reference Measurement Channel 12.2 kbps	As specified in C.3.1 and C.2.1
Power Control		On	
Active cell		Cell 1	
Reporting range	dB	3	Applicable for event 1A and 1B
Hysteresis	dB	0	
W		0	Applicable for event 1A and 1B
Reporting deactivation threshold		0	Applicable for event 1A
Time to Trigger	ms	0	
Filter coefficient		0	
Monitored cell list size		24	NOTE: See Annex I for cell information.
T1	s	5	
T2	s	5	
T3	s	1	
T4	s	5	

Table 8.6.1.1.2: Cell specific test parameters for Event triggered reporting in AWGN propagation conditions

Parameter	Unit	Cell 1				Cell 2			
		T1	T2	T3	T4	T1	T2	T3	T4
CPICH_Ec/lor	dB	-10				-10			
PCCPCH_Ec/lor	dB	-12				-12			
SCH_Ec/lor	dB	-12				-12			
PICH_Ec/lor	dB	-15				-15			
DPCH_Ec/lor	dB	Note 1				N/A		Note 1	
OCNS		Note 2				-0.941		Note 2	
\hat{I}_{or}/I_{oc}	dB	0	6.97	6.97	0	-Infinity	5.97	5.97	-Infinity
\hat{I}_{or} (Note 3)	dBm	-70	-63.03	-63.03	-70	-Infinity	-64.03	-64.03	-Infinity
I_{oc}	dBm/3.84 MHz	-70							
CPICH_Ec/lo	dB	-13	-13	-13	-13	-Infinity	-14	-14	-Infinity
Propagation Condition		AWGN							
Note 1: The DPCH level is controlled by the power control loop									
Note 2: The power of the OCNS channel that is added shall make the total power from the cell to be equal to I_{or} .									
Note 3: The nominal \hat{I}_{or} values, although not explicitly defined in 25.133 [2] are added here since they are implied and need to be identified so that the test equipment can be configured.									

8.6.1.1.4.2 Procedure

1. The RF parameters are set up according to T1 in table 8.6.1.1.3, with cell 1 active.
2. The UE is switched on.
3. A call is set up according to the test procedure specified in TS 34.108 [3] sub clause 7.3.2. The scrambling code is set to Cell2.
4. SS shall transmit a MEASUREMENT CONTROL message. T1 starts.
5. After 5 seconds from the beginning of T1, the SS shall switch the power settings from T1 to T2 in table 8.6.1.1.3.
6. UE shall transmit a MEASUREMENT REPORT message triggered by event 1A. The measurement reporting delay from the beginning of T2 shall be less than 880 ms. If the UE fails to report the event within the required delay, then the counter event1A_failure is increased by one. If the reporting delay for this event is within the required limit, the counter event1A_success is increased by one.

7. During the time period T2 the SS shall after the Event 1A triggered measurement is reported send an Active Set Update command with activation time “start of T3” adding cell 2 to the active set. The Active Set Update message shall be sent to the UE so that the whole message is available at the UE the RRC procedure delay prior to the beginning of T3.
8. After 6 seconds from the beginning of T2, the SS shall switch the power settings from T2 to T4 in table 8.6.1.1.3.
9. UE shall transmit a MEASUREMENT REPORT message triggered by event 1B. The measurement reporting delay from the beginning of T4 shall be less than 280 ms. If the UE fails to report the event within the required delay, then the counter event1B_failure is increased by one. If the reporting delay for this event is within the required limit, the counter event1B_success is increased by one.
10. After the SS receive the MEASUREMENT REPORT message in step 9) or 5 seconds after the beginning of T4, the SS shall transmits a RRC Connection Release message to make the UE to transit to idle mode.
11. SS shall sets the new primary code groups and primary codes on Cell2. Three different primary code groups and primary codes according to Annex I are used to turn on Cell2. Previous timing information of cell 2 is invalid in the UE. The RF parameters are set up according to T1.
12. Repeat steps 3-11 according to Annex F.6.2 Table 6.2.8. If one counter reaches the pass criterion, this counter is stopped and the remaining counters are continued. For the overall outcome of the test to be considered a pass, the counters for 1A events and for 1B events shall independen tly indicate a pass result. The test is stopped immediately and the test is considered to be a fail, if any counter reaches an early fail criterion.

Specific Message Contents

All messages indicated above shall use the same content as described in the default message content in clause 9 of 34.108 [3], with the following exceptions:

MEASUREMENT CONTROL message:

Information Element/Group name	Value/Remark
Message Type (10.2.17)	
UE information elements -RRC transaction identifier -Integrity check info -message authentication code -RRC message sequence number	0 SS calculates the value of MAC-I for this message and writes to this IE. The first/ leftmost bit of the bit string contains the most significant bit of the MAC-I. SS provides the value of this IE, from its internal counter.
Measurement Information elements -Measurement Identity -Measurement Command (10.3.7.46) -Measurement Reporting Mode (10.3.7.49) -Measurement Report Transfer Mode -Periodical Reporting / Event Trigger Reporting Mode -Additional measurements list (10.3.7.1)	1 Modify AM RLC Event trigger Not Present
-CHOICE <i>Measurement type</i> -Intra-frequency measurement (10.3.7.36) -Intra-frequency measurement objects list (10.3.7.33) -Intra-frequency measurement quantity (10.3.7.38) -Filter coefficient (10.3.7.9) -CHOICE mode -Measurement quantity -Intra-frequency reporting quantity (10.3.7.41)	Intra-frequency measurement Not Present 0 FDD CPICH_Ec/N0
-Reporting quantities for active set cells (10.3.7.5) -Cell synchronisation information reporting indicator -Cell Identity reporting indicator -CHOICE mode -CPICH Ec/N0 reporting indicator -CPICH RSCP reporting indicator -Pathloss reporting indicator	TRUE (Note 1) TRUE FDD TRUE TRUE FALSE
-Reporting quantities for monitored set cells (10.3.7.5) -Cell synchronisation information reporting indicator -Cell Identity reporting indicator -CHOICE mode -CPICH Ec/N0 reporting indicator -CPICH RSCP reporting indicator -Pathloss reporting indicator	TRUE (Note 1) TRUE FDD TRUE TRUE FALSE
-Reporting quantities for detected set cells (10.3.7.5)	Not Present
-Reporting cell status (10.3.7.61) -Measurement validity (10.3.7.51) -CHOICE report criteria -Intra-frequency measurement reporting criteria (10.3.7.39) -Parameters required for each event	Not Present Not Present Intra-frequency measurement reporting criteria 2
-Intra-frequency event identity -Triggering condition 2 -Reporting Range Constant -Cells forbidden to affect Reporting Range -W -Hysteresis -Threshold used frequency -Reporting deactivation threshold -Replacement activation threshold -Time to trigger -Amount of reporting -Reporting interval -Reporting cell status - CHOICE reported cell - Maximum number of reported cells	Event 1A Monitored set cells 3 dB Not Present 0 0 dB Not Present 0 Not Present 0 ms 1 0 ms (Note 2) Report cell within active set and/or monitored set cells on used frequency 3
-Intra-frequency event identity -Triggering condition 1 -Reporting Range Constant	Event 1B Active set cells 3 dB

Information Element/Group name	Value/Remark
-Cells forbidden to affect Reporting Range	Not Present
-W	0
-Hysteresis	0 dB
-Threshold used frequency	Not Present
-Reporting deactivation threshold	Not Present
-Replacement activation threshold	Not Present
-Time to trigger	0 ms
-Amount of reporting	Not Present
-Reporting interval	Not present
-Reporting cell status	
- CHOICE reported cell	Report cell within active set and/or monitored set cells on used frequency
- Maximum number of reported cells	3
Physical channel information elements	
-DPCH compressed mode status info (10.3.6.34)	Not Present
Note 1: The SFN-CFN observed time difference is calculated from the OFF and Tm parameters contained in the IE "Cell synchronisation information", TS 25.331, clause 10.3.7.6. According to TS 25.331, 8.6.7.7, this IE is included in MEASUREMENT REPORT if IE "Cell synchronisation information reporting indicator" in IE "Cell reporting quantities" TS 25.331, clause 10.3.7.5 is set to TRUE in MEASUREMENT CONTROL.	
Note 2: Reporting interval = 0 ms means no periodical reporting	

MEASUREMENT REPORT message for Intra frequency test cases

This message is common for all intra frequency test cases is described in Annex I.

8.6.1.1.5 Test requirements

For the test to pass, the total number of successful tests shall be at least 90%, of the cases with a confidence level of 95%. For the overall outcome of the test to be considered a pass, the counters for 1A events and for 1B events shall independently indicate a pass result.

Table 8.6.1.1.3: Test requirements for Event triggered reporting in AWGN propagation conditions

Parameter	Unit	Cell 1				Cell 2			
		T1	T2	T3	T4	T1	T2	T3	T4
CPICH_Ec/lor	dB	-9.3				-9.3			
PCCPCH_Ec/lor	dB	-11.3				-11.3			
SCH_Ec/lor	dB	-11.3				-11.3			
PICH_Ec/lor	dB	-14.3				-14.3			
DPCH_Ec/lor	dB	Note 1				N/A		Note 1	
OCNS		Note 2				-1.13		Note 2	
\hat{I}_{or} / I_{oc} (Note 3)	dB	0	7.0	7.0	0	-Infinity	6.0	6.0	-Infinity
\hat{I}_{or}	dBm	-70	-63.0	-63.0	-70	-Infinity	-64.0	-64.0	-Infinity
I_{oc}	dBm/3.84 MHz	-70							
CPICH_Ec/lo (Note 3)	dB	-12.3	-12.3	-12.3	-12.3	-Infinity	-13.3	-13.3	-Infinity
Propagation Condition		AWGN							
Note 1: The DPCH level is controlled by the power control loop Note 2: The power of the OCNS channel that is added shall make the total power from the cell to be equal to I_{or} . Note 3: These parameters are not directly settable, but are derived by calculation from the settable parameters..									

NOTE: If the above Test Requirement differs from the Minimum Requirement then the Test Tolerance applied for this test is non-zero. The Test Tolerance for this test is defined in clause F.2 and the explanation of

8.6.1.1A Event triggered reporting in AWGN propagation conditions (Rel-4 and later)

8.6.1.1A.1 Definition and applicability

In the event triggered reporting period the measurement reporting delay is defined as the time between any event that will trigger a measurement report until the UE starts to transmit over the Uu interface. This requirement assumes that the measurement report is not delayed by other RRC signalling on the DCCH. This measurement reporting delay excludes a delay uncertainty resulted when inserting the measurement report to the TTI of the uplink DCCH. The delay uncertainty is twice the TTI of the uplink DCCH.

The requirements and this test apply to the Rel-4 and later FDD UE.

8.6.1.1A.2 Minimum requirements

The UE shall be able to identify and decode the SFN of a new detectable cell belonging to the monitored set within

$$T_{\text{identify intra}} = \text{Max} \left\{ 800, T_{\text{basic identify FDD, intra}} \cdot \frac{T_{\text{Measurement Period, Intra}}}{T_{\text{Intra}}} \right\} \text{ms}$$

A cell shall be considered detectable when CPICH Ec/Io \geq -20 dB, SCH_Ec/Io \geq -20 dB for at least one channel tap and SCH_Ec/Ior is equally divided between primary synchronisation code and secondary synchronisation code. When L3 filtering is used an additional delay can be expected.

In case of conflict when a compressed gap sequence is activated the UE may choose to prioritise the SFN decoding.

The UE shall be able to identify a new detectable cell not belonging to the monitored set within

$$T_{\text{identify detected set}} = 30s$$

when CPICH Ec/Io \geq -20 dB, SCH_Ec/Io \geq -17 dB and SCH_Ec/Ior is equally divided between primary synchronisation code and secondary synchronisation code. When L3 filtering is used an additional delay can be expected.

In the CELL_DCH state the measurement period for intra frequency measurements is 200 ms. When no transmission gap pattern sequence is activated, the UE shall be capable of performing CPICH measurements for 8 identified intra-frequency cells of the monitored set and/or the active set, and the UE physical layer shall be capable of reporting measurements to higher layers with the measurement period of 200 ms. When one or more transmission gap pattern sequences are activated, the UE shall be capable of performing CPICH measurements for at least $Y_{\text{measurement intra}}$ cells, where $Y_{\text{measurement intra}}$ is defined in the following equation. The measurement accuracy for all measured cells shall be as specified in the sub-clause 9.1.1 and 9.1.2 of TS 25.133 [2]. If the UE has identified more than $Y_{\text{measurement intra}}$ cells, the UE shall perform measurements of all identified cells but the reporting rate of CPICH measurements of cells from UE physical layer to higher layers may be decreased.

$$Y_{\text{measurement intra}} = \text{Floor} \left\{ X_{\text{basic measurement FDD}} \cdot \frac{T_{\text{Intra}}}{T_{\text{Measurement Period, Intra}}} \right\} \text{ cells}$$

where

$$X_{\text{basic measurement FDD}} = 8 \text{ (cells)}$$

$$T_{\text{Measurement_Period Intra}} = 200 \text{ ms. The measurement period for Intra frequency CPICH measurements.}$$

T_{Intra} : This is the minimum time that is available for intra frequency measurements, during the measurement period with an arbitrarily chosen timing.

$T_{\text{basic_identify_FDD, intra}} = 800 \text{ ms. This is the time period used in the intra frequency equation where the maximum allowed time for the UE to identify a new FDD cell is defined.}$

The UE shall furthermore be capable of performing CPICH measurements for at least 1 detected intra-frequency cell, in the detected set, and the UE physical layer shall be capable of reporting measurements to higher layers with the measurement period of 10 s. The measurement accuracy for all measured cells shall be as specified in the sub-clause 9.1.1 and 9.1.2 of TS 25.133 [2].

Reported measurements contained in event triggered measurement reports shall meet the requirements in section 9 of TS 25.133 [2].

The UE shall not send event triggered measurement reports, as long as the reporting criteria are not fulfilled.

The measurement reporting delay is defined as the time between any event that will trigger a measurement report until the UE starts to transmit over the Uu interface. This requirement assumes that the measurement report is not delayed by other RRC signalling on the DCCH. This measurement reporting delay excludes a delay uncertainty resulted when inserting the measurement report to the TTI of the uplink DCCH. The delay uncertainty is twice the TTI of the uplink DCCH.

The event triggered measurement reporting delay, on cells belonging to monitored set, measured without L3 filtering, shall be less than the above defined $T_{\text{identify_intra}}$ defined above.

If a cell, belonging to monitored set, which the UE has identified and measured at least once over the measurement period, becomes undetectable for a period < 5 seconds and then the cell becomes detectable again and triggers an event, the measurement reporting delay shall be less than $T_{\text{Measurement_Period Intra}}$ ms provided the timing to that cell has not changed more than ± 32 chips, the UE CPICH measurement capabilities defined above are valid and L3 filtering has not been used. When L3 filtering is used an additional delay can be expected.

If a cell belonging to monitored set has been detectable at least for the time period $T_{\text{identify_intra}}$ and then enters or leaves the reporting range, the event triggered measurement reporting delay shall be less than $T_{\text{Measurement_Period Intra}}$ when the L3 filter has not been used and the UE CPICH measurement capabilities defined above are valid.

The event triggered measurement reporting delay on cells not belonging to monitored set, measured without L3 filtering, shall be less than the above defined $T_{\text{identify_detected set}}$ defined above.

The normative reference for these requirements is TS 25.133 [2] clauses 8.1.2.2 and A.8.1.1.

8.6.1.1A.3 Test purpose

To verify that the UE meets the minimum requirements.

8.6.1.1A.4 Method of test

8.6.1.1A.4.1 Initial conditions

Test environment: normal; see clauses G.2.1 and G.2.2.

Frequencies to be tested: mid range; see clause G.2.4.

The test parameters are given in tables 8.6.1.1A.1 to 8.6.1.1A.3 below. In the measurement control information it is indicated to the UE that event-triggered reporting with Event 1A and 1B shall be used. The test consists of three successive time periods, with a time duration of T1, T2 and T3 respectively. During time duration T1, the UE shall not have any timing information of cell 2.

Table 8.6.1.1A.1: General test parameters for Event triggered reporting in AWGN propagation conditions

Parameter	Unit	Value	Comment
DCH parameters		DL and UL Reference Measurement Channel 12.2 kbps	As specified in C.3.1 and C.2.1
Power Control		On	
Active cell		Cell 1	
Reporting range	dB	3	Applicable for event 1A and 1B
Hysteresis	dB	0	
W		1	Applicable for event 1A and 1B
Reporting deactivation threshold		0	Applicable for event 1A
Time to Trigger	ms	0	
Filter coefficient		0	
Monitored cell list size		24	NOTE: See Annex I for cell information
T1	s	5	
T2	s	5	
T3	s	5	

Table 8.6.1.1A.2: Cell specific test parameters for Event triggered reporting in AWGN propagation conditions

Parameter	Unit	Cell 1			Cell 2		
		T1	T2	T3	T1	T2	T3
CPICH_Ec/I _{or}	dB		-10			-10	
PCCPCH_Ec/I _{or}	dB		-12			-12	
SCH_Ec/I _{or}	dB		-12			-12	
PICH_Ec/I _{or}	dB		-15			-15	
DPCH_Ec/I _{or}	dB		Note 1			N/A	
OCNS_Ec/I _{or}	dB		Note 2			-0.941	
\hat{I}_{or}/I_{oc}	dB	0	6.97	0	-Infinity	5.97	-Infinity
\hat{I}_{or} (Note 3)	dBm	-70	-63.03	-70	-Infinity	-64.03	-Infinity
I_{oc}	dBm/3.84 MHz	-70					
CPICH_Ec/I _o	dB	-13	-13	-13	-Infinity	-14	-Infinity
Propagation Condition		AWGN					
Note 1: The DPCH level is controlled by the power control loop Note 2: The power of the OCNS channel that is added shall make the total power from the cell to be equal to I_{or} . Note 3: The nominal \hat{I}_{or} values, although not explicitly defined in 25.133 [2] are added here since they are implied and need to be identified so that the test equipment can be configured.							

8.6.1.1A.4.2 Procedure

1. The RF parameters are set up according to T1 in table 8.6.1.1A.3.
2. The UE is switched on.
3. A call is set up according to the test procedure specified in TS 34.108 [3] sub clause 7.3.2. The scrambling code is set to Cell2.
4. SS shall transmit a MEASUREMENT CONTROL message. T1 starts.
5. After 5 seconds from the beginning of T1, the SS shall switch the power settings from T1 to T2 in table 8.6.1.1A.3.
6. UE shall transmit a MEASUREMENT REPORT message triggered by event 1A. The measurement reporting delay from the beginning of T2 shall be less than 880 ms. If the UE fails to report the event within the required delay, then the counter event1A_failure is increased by one. If the reporting delay for this event is within the required limit, the counter event1A_success is increased by one.
7. After 5 seconds from the beginning of T2, the SS shall switch the power settings from T2 to T3 in table 8.6.1.1A.3.
8. UE shall transmit a MEASUREMENT REPORT message triggered by event 1B. The measurement reporting delay from the beginning of T3 shall be less than 280 ms. If the UE fails to report the event within the required delay, then the counter event1B_failure is increased by one. If the reporting delay for this event is within the required limit, the counter event1B_success is increased by one.
9. After the SS receives the MEASUREMENT REPORT message in step 8) or 5 seconds after the beginning of T3, the SS shall transmits a RRC Connection Release message to make the UE to transit to idle mode.
10. SS shall sets the new primary code group and primary code on Cell2. Three different primary code groups and primary codes according to Annex I are used to turn on Cell2. Previous timing information of cell 2 is invalid in the UE. The RF parameters are set up according to T1 in table 8.6.1.1A.3.
11. Repeat steps 3-10 according to Annex F.6.2 Table 6.2.8. If one counter reaches the pass criterion, this counter is stopped and the remaining counters are continued. For the overall outcome of the test to be considered a pass, the counters for 1A events and for 1B events shall independently indicate a pass result. The test is stopped immediately and the test is considered to be a fail, if any counter reaches an early fail criterion.

Specific Message Contents

All messages indicated above shall use the same content as described in the default message content in clause 9 of 34.108 [3], with the following exceptions:

MEASUREMENT CONTROL message:

Information Element/Group name	Value/Remark
Message Type (10.2.17)	
UE information elements	
-RRC transaction identifier	0
-Integrity check info	
-message authentication code	SS calculates the value of MAC-I for this message and writes to this IE. The first/ leftmost bit of the bit string contains the most significant bit of the MAC-I.
-RRC message sequence number	SS provides the value of this IE, from its internal counter.
Measurement Information elements	
-Measurement Identity	1
-Measurement Command (10.3.7.46)	Modify
-Measurement Reporting Mode (10.3.7.49)	
-Measurement Report Transfer Mode	AM RLC
-Periodical Reporting / Event Trigger Reporting Mode	Event trigger
-Additional measurements list (10.3.7.1)	Not Present
-CHOICE <i>Measurement type</i>	Intra-frequency measurement
-Intra-frequency measurement (10.3.7.36)	
-Intra-frequency measurement objects list (10.3.7.33)	Not Present
-Intra-frequency measurement quantity (10.3.7.38)	
-Filter coefficient (10.3.7.9)	0
-CHOICE mode	FDD
-Measurement quantity	CPICH_Ec/N0
-Intra-frequency reporting quantity (10.3.7.41)	
-Reporting quantities for active set cells (10.3.7.5)	
-Cell synchronisation information reporting indicator	TRUE (Note 1)
-Cell Identity reporting indicator	TRUE
-CHOICE mode	FDD
-CPICH Ec/N0 reporting indicator	TRUE
-CPICH RSCP reporting indicator	TRUE
-Pathloss reporting indicator	FALSE
-Reporting quantities for monitored set cells (10.3.7.5)	
-Cell synchronisation information reporting indicator	TRUE (Note 1)
-Cell Identity reporting indicator	TRUE
-CHOICE mode	FDD
-CPICH Ec/N0 reporting indicator	TRUE
-CPICH RSCP reporting indicator	TRUE
-Pathloss reporting indicator	FALSE
-Reporting quantities for detected set cells (10.3.7.5)	Not Present
-Reporting cell status (10.3.7.61)	Not Present
-Measurement validity (10.3.7.51)	Not Present
-CHOICE report criteria	Intra-frequency measurement reporting criteria
-Intra-frequency measurement reporting criteria (10.3.7.39)	
-Parameters required for each event	2
-Intra-frequency event identity	Event 1A
-Triggering condition 2	Monitored set cells
-Reporting Range Constant	3 dB
-Cells forbidden to affect Reporting Range	Not Present
-W	1.0
-Hysteresis	0 dB
-Threshold used frequency	Not Present
-Reporting deactivation threshold	0
-Replacement activation threshold	Not Present
-Time to trigger	0 ms
-Amount of reporting	Infinity
-Reporting interval	0 ms (Note 2)
-Reporting cell status	
- CHOICE reported cell	Report cell within active set and/or monitored set cells on used frequency
- Maximum number of reported cells	3
-Intra-frequency event identity	Event 1B
-Triggering condition 1	Active set cells and monitored set cells
-Reporting Range Constant	3 dB

Information Element/Group name	Value/Remark
-Cells forbidden to affect Reporting Range	Not Present
-W	1.0
-Hysteresis	0 dB
-Threshold used frequency	Not Present
-Reporting deactivation threshold	Not Present
-Replacement activation threshold	Not Present
-Time to trigger	0 ms
-Amount of reporting	Not Present
-Reporting interval	0 ms (note 2)
-Reporting cell status	
- CHOICE reported cell	Report cell within active set and/or monitored set cells on used frequency
- Maximum number of reported cells	3
Physical channel information elements	
-DPCH compressed mode status info (10.3.6.34)	Not Present
Note 1: The SFN-CFN observed time difference is calculated from the OFF and Tm parameters contained in the IE "Cell synchronisation information", TS 25.331, clause 10.3.7.6. According to TS 25.331, 8.6.7.7, this IE is included in MEASUREMENT REPORT if IE "Cell synchronisation information reporting indicator" in IE "Cell reporting quantities" TS 25.331, clause 10.3.7.5 is set to TRUE in MEASUREMENT CONTROL.	
Note 2: Reporting interval = 0 ms means no periodical reporting	

MEASUREMENT REPORT message for Intra frequency test cases

This message is common for all intra frequency test cases is described in Annex I.

8.6.1.1A.5 Test requirements

For the test to pass, the total number of successful tests shall be at least 90%, of the cases with a confidence level of 95%. For the overall outcome of the test to be considered a pass, the counters for 1A events and for 1B events shall independently indicate a pass result.

Table 8.6.1.1A.3: Test requirements for Event triggered reporting in AWGN propagation conditions

Parameter	Unit	Cell 1			Cell 2		
		T1	T2	T3	T1	T2	T3
CPICH_Ec/Ior	dB	-9.3			-9.3		
PCCPCH_Ec/Ior	dB	-11.3			-11.3		
SCH_Ec/Ior	dB	-11.3			-11.3		
PICH_Ec/Ior	dB	-14.3			-14.3		
DPCH_Ec/Ior	dB	Note 1			N/A		
OCNS		Note 2			-1.13		
\hat{I}_{or}/I_{oc} (Note 3)	dB	0	7.0	0	-Infinity	6.0	-Infinity
\hat{I}_{or}	dBm	-70	-63.0	-70	-Infinity	-64.0	-Infinity
I_{oc}	dBm/3.84 MHz	-70					
CPICH_Ec/Io (Note 3)	dB	-12.3	-12.3	-12.3	-Infinity	-13.3	-Infinity
Propagation Condition		AWGN					

Note 1: The DPCH level is controlled by the power control loop
 Note 2: The power of the OCNS channel that is added shall make the total power from the cell to be equal to I_{or} .
 Note 3: These parameters are not directly settable, but are derived by calculation from the settable parameters..

NOTE: If the above Test Requirement differs from the Minimum Requirement then the Test Tolerance applied for this test is non-zero. The Test Tolerance for this test is defined in clause F.2 and the explanation of how the Minimum Requirement has been relaxed by the Test Tolerance is given in clause F.4.

8.6.1.2 Event triggered reporting of multiple neighbours in AWGN propagation condition (R99)

8.6.1.2.1 Definition and applicability

In the event triggered reporting period the measurement reporting delay is defined as the time between any event that will trigger a measurement report until the UE starts to transmit over the Uu interface. This requirement assumes that the measurement report is not delayed by other RRC signalling on the DCCH. This measurement reporting delay excludes a delay uncertainty resulted when inserting the measurement report to the TTI of the uplink DCCH. The delay uncertainty is twice the TTI of the uplink DCCH.

The requirements and this test apply to the Release 99 FDD UE.

8.6.1.2.2 Minimum requirements

The requirements are the same as in sub clause 8.6.1.1.2.

The normative reference for these requirements is TS 25.133 [2] clauses 8.1.2.2 and A.8.1.2.

8.6.1.2.3 Test purpose

To verify that the UE meets the minimum requirements.

8.6.1.2.4 Method of test

8.6.1.2.4.1 Initial conditions

Test environment: normal; see clauses G.2.1 and G.2.2.

Frequencies to be tested: mid range; see clause G.2.4.

The initial test parameters are given in table 8.6.1.2.4.

Table 8.6.1.2.1: Cell specific initial test parameters for Event triggered reporting of multiple neighbours in AWGN propagation conditions

Parameter	Unit	Cell 1	Cell 2	Cell3
		T0	T0	T0
CPICH_Ec/I _{or}	dB	-10	-10	-10
PCCPCH_Ec/I _{or}	dB	-12	-12	-12
SCH_Ec/I _{or}	dB	-12	-12	-12
PICH_Ec/I _{or}	dB	-15	-15	-15
DPCH_Ec/I _{or}	dB	Note 1	N/A	N/A
OCNS_Ec/I _{or}	dB	Note 2	-0.941	-0.941
\hat{I}_{or}/I_{oc}	dB	0	-Inf	-Inf
\hat{I}_{or} (Note 3)	dBm	-85	-Inf	-Inf
I_{oc}	dBm/3.84 MHz	-85		
CPICH_Ec/I _o	dB	-13	-Inf	-Inf
Propagation Condition		AWGN		
Note 1: The DPCH level is controlled by the power control loop.				
Note 2: The power of the OCNS channel that is added shall make the total power from the cell to be equal to I _{or} .				
Note 3: The nominal \hat{I}_{or} values, although not explicitly defined in 25.133 [2] are added here since they are implied and need to be identified so that the test equipment can be configured.				

The test parameters are given in table 8.6.1.2.2 and 8.6.1.2.5. In the measurement control information it is indicated to the UE that event-triggered reporting with Event 1A, 1C and 1B shall be used and the periodical reporting of the events is not applied. The CPICH Ec/I_o and SFN-CFN observed time difference shall be reported together with Event 1A. The test consists of six successive time periods, with a time duration of T1, T2, T3, T4, T5 and T6 respectively. In the initial condition before the time T1, defined as T0, only Cell 1 is active.

Table 8.6.1.2.2: General test parameters for Event triggered reporting of multiple neighbours in AWGN propagation conditions

Parameter	Unit	Value	Comment
DCH parameters		DL and UL Reference Measurement Channel 12.2 kbps	As specified in C.3.1 and C.2.1
Power Control		On	
Active cell		Cell 1	
Reporting range	dB	3	Applicable for event 1A and 1B
Hysteresis	dB	0	
W		0	Applicable for event 1A and 1B
Replacement activation threshold		0	Applicable for event 1C
Reporting deactivation threshold		0	Applicable for event 1A
Time to Trigger	ms	0	
Filter coefficient		0	
Monitored cell list size		32	NOTE: See Annex I for cell information.
T1	s	10	
T2	s	1	
T3	s	10	
T4	s	4	
T5	s	1	
T6	s	10	

Table 8.6.1.2.3: Cell specific test parameters for Event triggered reporting of multiple neighbours in AWGN propagation condition

Parameter	Unit	Cell 1						Cell 2						Cell3								
		T1	T2	T3	T4	T5	T6	T1	T2	T3	T4	T5	T6	T1	T2	T3	T4	T5	T6			
CPICH_Ec/I _{or}	dB	-10						-10						-10								
PCCPCH_Ec/I _{or}	dB	-12						-12						-12								
SCH_Ec/I _{or}	dB	-12						-12						-12								
PICH_Ec/I _{or}	dB	-15						-15						-15								
DPCH_Ec/I _{or}	dB	Note 1						N/A						N/A	Note 1			N/A				
OCNS_Ec/I _{or}	dB	Note 2						-0.941						-0.941	Note 2			-0.941				
\hat{I}_{or}/I_{oc}	dB	6.97		6.93	5.97		6.12		-Inf		9.43	6.97		7.62		5.97		6.93	-Inf		5.62	
\hat{I}_{or} (Note 3)	dBm	-78.03		-78.07	-79.03		-78.88		-Inf		-75.57	-78.03		-77.38		-79.03		-78.07	-Inf		-79.38	
I_{oc}	dBm/ 3.84 MHz	-85																				
CPICH_Ec/I _o	dB	-13		-16	-14		-15.5		-Inf		-13.5	-13		-14		-14		-16	-Inf		-16	
Propagation Condition		AWGN																				
Note 1:	The DPCH level is controlled by the power control loop																					
Note 2:	The power of the OCNS channel that is added shall make the total power from the cell to be equal to I _{or}																					
Note 3:	The nominal \hat{I}_{or} values, although not explicitly defined in 25.133 [2] are added here since they are implied and need to be identified so that the test equipment can be configured.																					

8.6.1.2.4.2 Procedure

- 1) The RF parameters are set up according to T0 in table 8.6.1.2.4.
- 2) The UE is switched on.
- 3) A call is set up according to the test procedure specified in TS 34.108 [3] sub clause 7.3.2. The scrambling code is set to Cell2 and Cell3.
- 4) SS shall transmit the initial MEASUREMENT CONTROL message.
- 5) 5 seconds after step4 has completed, the SS shall switch the power settings for T0 to T1 in table 8.6.1.2.5.
- 6) UE shall transmit a MEASUREMENT REPORT message for Cell 3 triggered by event 1A. The measurement reporting delay from the beginning of T1 shall be less than 880 ms. If the UE fails to report the event within the required delay, then the counter event1A_failure is increased by one. If the reporting delay for this event is within the required limit, the counter event1A_success is increased by one.
- 7) During the time period T1, the SS shall after the Event 1A triggered measurement is reported send an Active Set Update command with activation time "start of T2" adding cell 3 to the active set. The Active Set Update message shall be sent to the UE so that the whole message is available at the UE at least the RRC procedure delay prior to the beginning of T2.
- 8) UE may transmit a MEASUREMENT REPORT message for Cell 3 triggered by event 1C. In case it doesn't this shall not be considered as a failure.
- 9) After 11 seconds from the beginning of T1, the SS shall switch the power settings from T1 to T3 in table 8.6.1.2.5.
- 10) UE shall transmit a MEASUREMENT REPORT message for Cell 2 triggered by event 1C. The measurement reporting delay from the beginning of T3 shall be less than 880 ms. If the UE fails to report the event within the required delay, then the counter event1C_failure is increased by one. If the reporting delay for this event is within the required limit, the counter event1C_success is increased by one.
- 11) UE shall transmit a MEASUREMENT REPORT message for Cell 2 triggered by event 1A. The measurement reporting delay from the beginning of T3 shall be less than 880 ms. If the UE fails to report the event within the required delay, then the counter event1A_failure is increased by one. If the reporting delay for this event is within the required limit, the counter event1A_success is increased by one.
- 12) SS shall transmit the measurement control message to disable event 1C reporting.
- 13) After 10 seconds from the beginning of T3, the SS shall switch the power settings from T3 to T4 in table 8.6.1.2.5.
- 14) UE shall transmit a MEASUREMENT REPORT message for Cell 3 triggered by event 1B. The measurement reporting delay from the beginning of T4 shall be less than 280 ms. If the UE fails to report the event within the required delay, then the counter event1B_failure is increased by one. If the reporting delay for this event is within the required limit, the counter event1B_success is increased by one.
- 15) During the time period T4, SS shall after the Event 1B triggered measurement is reported send an Active Set Update command with activation time "start of T5" removing cell 3 from the active set. The Active Set Update message shall be sent to the UE so that the whole message is available at the UE at least the RRC procedure delay prior to the beginning of T5.
- 16) Void.
- 17) After 5 seconds from the beginning of T4, the SS shall switch the power settings from T5 to T6 in table 8.6.1.2.5.
- 18) UE shall transmit a MEASUREMENT REPORT message for Cell 3 triggered by event 1A. The measurement reporting delay from the beginning of T6 shall be less than 280 ms. If the UE fails to report the event within the required delay, then the counter event1A_failure is increased by one. If the reporting delay for this event is within the required limit, the counter event1A_success is increased by one.
- 19) Void.

20) Void.

21) After the SS receive the MEASUREMENT REPORT message in step 18) or 10 seconds after the beginning of T6, the SS shall transmit a RRC Connection Release message to make the UE to transit to idle mode.

22) SS shall set the new primary code group and primary code on Cell2 and Cell3. Three different primary code groups and primary codes according to Annex I are used to turn on Cell2 and Cell3. Previous timing information of Cell 2 and Cell3 are invalid in the UE. The RF parameters are set up according to T0 in table 8.6.1.2.4.

23) Repeat steps 3-22 used with three different primary code groups and primary codes on Cell2 and Cell3 until the confidence level according to annex F.6.2 is achieved. If one counter reaches the pass criterion, this counter is stopped and the remaining counters are continued. For the overall outcome of the test to be considered a pass, the counters for 1A events and for 1B events and for 1C events shall independently indicate a pass result. The test is stopped immediately and the test is considered to be a fail, if any counter reaches an early fail criterion.

Specific Message Contents

All messages indicated above shall use the same content as described in the default message content in clause 9 of 34.108 [3], with the following exceptions:

Initial MEASUREMENT CONTROL message:

Information Element/Group name	Value/Remark
Message Type (10.2.17)	
UE information elements	
-RRC transaction identifier	0
-Integrity check info	
-message authentication code	SS calculates the value of MAC-I for this message and writes to this IE. The first/ leftmost bit of the bit string contains the most significant bit of the MAC-I.
-RRC message sequence number	SS provides the value of this IE, from its internal counter.
Measurement Information elements	
-Measurement Identity	1
-Measurement Command (10.3.7.46)	Modify
-Measurement Reporting Mode (10.3.7.49)	
-Measurement Report Transfer Mode	AM RLC
-Periodical Reporting / Event Trigger Reporting Mode	Event trigger
-Additional measurements list (10.3.7.1)	Not Present
-CHOICE <i>Measurement type</i>	Intra-frequency measurement
-Intra-frequency measurement (10.3.7.36)	
-Intra-frequency measurement objects list (10.3.7.33)	Not Present
-Intra-frequency measurement quantity (10.3.7.38)	
-Filter coefficient (10.3.7.9)	0
-CHOICE mode	FDD
-Measurement quantity	CPICH_Ec/N0
-Intra-frequency reporting quantity (10.3.7.41)	
-Reporting quantities for active set cells (10.3.7.5)	
-Cell synchronisation information reporting indicator	TRUE (Note 1)
-Cell Identity reporting indicator	TRUE
-CHOICE mode	FDD
-CPICH Ec/N0 reporting indicator	TRUE
-CPICH RSCP reporting indicator	TRUE
-Pathloss reporting indicator	FALSE
-Reporting quantities for monitored set cells (10.3.7.5)	
-Cell synchronisation information reporting indicator	TRUE (Note 1)
-Cell Identity reporting indicator	TRUE
-CHOICE mode	FDD
-CPICH Ec/N0 reporting indicator	TRUE
-CPICH RSCP reporting indicator	TRUE
-Pathloss reporting indicator	FALSE
-Reporting quantities for detected set cells (10.3.7.5)	Not Present
-Reporting cell status (10.3.7.61)	Not Present
-Measurement validity (10.3.7.51)	Not Present
-CHOICE report criteria	Intra-frequency measurement reporting criteria
-Intra-frequency measurement reporting criteria (10.3.7.39)	
-Parameters required for each event	3
-Intra-frequency event identity	Event 1A
-Triggering condition 2	Monitored set cells
-Reporting Range Constant	3 dB
-Cells forbidden to affect Reporting Range	Not Present
-W	0
-Hysteresis	0 dB
-Threshold used frequency	Not Present
-Reporting deactivation threshold	0
-Replacement activation threshold	Not Present
-Time to trigger	0 ms
-Amount of reporting	1
-Reporting interval	0 ms (Note 2)
-Reporting cell status	
- CHOICE reported cell	Report cell within active set and/or monitored set cells on used frequency
- Maximum number of reported cells	3
-Intra-frequency event identity	Event 1B
-Triggering condition 1	Active set cells
-Reporting Range Constant	3 dB

Information Element/Group name	Value/Remark
-Cells forbidden to affect Reporting Range -W -Hysteresis -Threshold used frequency -Reporting deactivation threshold -Replacement activation threshold -Time to trigger -Amount of reporting -Reporting interval -Reporting cell status - CHOICE reported cell - Maximum number of reported cells	Not Present 0 0 dB Not Present Not Present Not Present 0 ms Not Present Not Present Report cell within active set and/or monitored set cells on used frequency 3
-Intra-frequency event identity -Reporting Range Constant -Cells forbidden to affect Reporting Range -W -Hysteresis -Threshold used frequency -Reporting deactivation threshold -Replacement activation threshold -Time to trigger -Amount of reporting -Reporting interval -Reporting cell status - CHOICE reported cell - Maximum number of reported cells	Event 1C Not present Not Present Not present 0 dB Not Present Not present 0 0 ms 1 0 ms (Note 2) Report cell within active set and/or monitored set cells on used frequency 3
Physical channel information elements -DPCH compressed mode status info (10.3.6.34)	Not Present
NOTE 1: The SFN-CFN observed time difference is calculated from the OFF and Tm parameters contained in the IE "Cell synchronisation information", TS 25.331, clause 10.3.7.6. According to TS 25.331, 8.6.7.7, this IE is included in MEASUREMENT REPORT if IE "Cell synchronisation information reporting indicator" in IE "Cell reporting quantities" TS 25.331, clause 10.3.7.5 is set to TRUE in MEASUREMENT CONTROL.	
NOTE 2: Reporting interval = 0 ms means no periodical reporting.	

MEASUREMENT CONTROL message to disable event 1C reporting:

Information Element/Group name	Value/Remark
Message Type (10.2.17)	
UE information elements	
-RRC transaction identifier	0
-Integrity check info	
-message authentication code	SS calculates the value of MAC-I for this message and writes to this IE. The first/ leftmost bit of the bit string contains the most significant bit of the MAC-I.
-RRC message sequence number	SS provides the value of this IE, from its internal counter.
Measurement Information elements	
-Measurement Identity	1
-Measurement Command (10.3.7.46)	Modify
-Measurement Reporting Mode (10.3.7.49)	
-Measurement Report Transfer Mode	AM RLC
-Periodical Reporting / Event Trigger Reporting Mode	Event trigger
-Additional measurements list (10.3.7.1)	Not Present
-CHOICE <i>Measurement type</i>	Intra-frequency measurement
-Intra-frequency measurement (10.3.7.36)	
-Intra-frequency measurement objects list (10.3.7.33)	Not Present
-Intra-frequency measurement quantity (10.3.7.38)	
-Filter coefficient (10.3.7.9)	0
-CHOICE mode	FDD
-Measurement quantity	CPICH_Ec/NO
-Intra-frequency reporting quantity (10.3.7.41)	Not Present
-Reporting cell status (10.3.7.61)	Not Present
-Measurement validity (10.3.7.51)	Not Present
-CHOICE report criteria	Intra-frequency measurement reporting criteria
-Intra-frequency measurement reporting criteria (10.3.7.39)	
-Parameters required for each event	2
-Intra-frequency event identity	Event 1A
-Triggering condition 2	Monitored set cells
-Reporting Range Constant	3 dB
-Cells forbidden to affect Reporting Range	Not Present
-W	0
-Hysteresis	0 dB
-Threshold used frequency	Not Present
-Reporting deactivation threshold	0
-Replacement activation threshold	Not Present
-Time to trigger	0 ms
-Amount of reporting	1
-Reporting interval	0 ms (Note 1)
-Reporting cell status	
- CHOICE reported cell	Report cell within active set and/or monitored set cells on used frequency
- Maximum number of reported cells	3
-Intra-frequency event identity	Event 1B
-Triggering condition 1	Active set cells
-Reporting Range Constant	3 dB
-Cells forbidden to affect Reporting Range	Not Present
-W	0
-Hysteresis	0 dB
-Threshold used frequency	Not Present
-Reporting deactivation threshold	Not Present
-Replacement activation threshold	Not Present
-Time to trigger	0 ms
-Amount of reporting	Not Present
-Reporting interval	Not Present
-Reporting cell status	
- CHOICE reported cell	Report cell within active set and/or monitored set cells on used frequency
- Maximum number of reported cells	3
Physical channel information elements	
-DPCH compressed mode status info (10.3.6.34)	Not Present

Information Element/Group name	Value/Remark
NOTE 1: Reporting interval = 0 ms means no periodical reporting.	

MEASUREMENT REPORT message for Intra frequency test cases

This message is common for all intra frequency test cases is described in Annex I.

8.6.1.2.5 Test requirements

For the test to pass, the total number of successful tests shall be at least 90%, of the cases with a confidence level of 95%. For the overall outcome of the test to be considered a pass, the counters for 1A events and for 1B events and for 1C events shall independently indicate a pass result.

Table 8.6.1.2.4: Initial test requirements for Event triggered reporting of multiple neighbours in AWGN propagation conditions

Parameter	Unit	Cell 1	Cell 2	Cell3
		T0	T0	T0
CPICH_Ec/I _{or}	dB	-9.3	-9.3	-9.3
PCCPCH_Ec/I _{or}	dB	-11.3	-11.3	-11.3
SCH_Ec/I _{or}	dB	-11.3	-11.3	-11.3
PICH_Ec/I _{or}	dB	-14.3	-14.3	-14.3
DPCH_Ec/I _{or}	dB	Note 1	N/A	N/A
OCNS_Ec/I _{or}	dB	Note 2	-1.13	-1.13
\hat{I}_{or}/I_{oc} (Note 3)	dB	0	-Inf	-Inf
\hat{I}_{or}	dBm	-85	-Inf	-Inf
I_{oc}	dBm/3.84 MHz	-85		
CPICH_Ec/I _o (Note 3)	dB	-12.3	-Inf	-Inf
Propagation Condition		AWGN		
Note 1: The DPCH level is controlled by the power control loop.				
Note 2: The power of the OCNS channel that is added shall make the total power from the cell to be equal to I _{or} .				
Note 1: These parameters are not directly settable, but are derived by calculation from the settable parameters.				

Table 8.6.1.2.5: Test requirements for Event triggered reporting of multiple neighbours in AWGN propagation condition

Parameter	Unit	Cell 1						Cell 2						Cell3											
		T1	T2	T3	T4	T5	T6	T1	T2	T3	T4	T5	T6	T1	T2	T3	T4	T5	T6						
CPICH_Ec/lor	dB	-9.3						-9.3						-9.3											
PCCPCH_Ec/lor	dB	-11.3						-11.3						-11.3											
SCH_Ec/lor	dB	-11.3						-11.3						-11.3											
PICH_Ec/lor	dB	-14.3						-14.3						-14.3											
DPCH_Ec/lor	dB	Note 1						N/A						N/A	Note 1			N/A							
OCNS_Ec/lor	dB	Note 2						-1.13						-1.13	Note 2			-1.13							
\hat{I}_{or}/I_{oc} (Note 3)	dB	7.0		6.9		6.0		6.1		-Inf		9.4		7.0		7.6		6.0		6.9		-Inf		5.6	
\hat{I}_{or}	dBm	-78.0		-78.1		-79.0		-78.9		-Inf		-75.6		-78.0		-77.4		-79.0		-78.1		-Inf		-79.4	
I_{oc}	dBm/ 3.84 MHz	-85																							
CPICH_Ec/lor(Note 3)	dB	-12.3		-15.3		-13.3		-14.8		-Inf		-12.8		-12.3		-13.3		-13.3		-15.3		-Inf		-15.3	
Propagation Condition		AWGN																							
Note 1: The DPCH level is controlled by the power control loop																									
Note 2: The power of the OCNS channel that is added shall make the total power from the cell to be equal to I_{or}																									
Note 3: These parameters are not directly settable, but are derived by calculation from the settable parameters.																									

NOTE: If the above Test Requirement differs from the Minimum Requirement then the Test Tolerance applied for this test is non-zero. The Test Tolerance for this test is defined in clause F.2 and the explanation of how the Minimum Requirement has been relaxed by the Test Tolerance is given in clause F.4.

8.6.1.2A Event triggered reporting of multiple neighbours in AWGN propagation condition (Rel-4 and later)

8.6.1.2A.1 Definition and applicability

In the event triggered reporting period the measurement reporting delay is defined as the time between any event that will trigger a measurement report until the UE starts to transmit over the Uu interface. This requirement assumes that the measurement report is not delayed by other RRC signalling on the DCCH. This measurement reporting delay excludes a delay uncertainty resulted when inserting the measurement report to the TTI of the uplink DCCH. The delay uncertainty is twice the TTI of the uplink DCCH.

The requirements and this test apply to the Rel-4 and later FDD UE.

8.6.1.2A.2 Minimum requirements

The requirements are the same as in sub clause 8.6.1.1A.2.

The normative reference for these requirements is TS 25.133 [2] clauses 8.1.2.2 and A.8.1.2.

8.6.1.2A.3 Test purpose

To verify that the UE meets the minimum requirements.

8.6.1.2A.4 Method of test

8.6.1.2A.4.1 Initial conditions

Test environment: normal; see clauses G.2.1 and G.2.2.

Frequencies to be tested: mid range; see clause G.2.4.

The initial test parameters are given in table 8.6.1.2A.4.

Table 8.6.1.2A.1: Cell specific initial test parameters for Event triggered reporting of multiple neighbours in AWGN propagation conditions

Parameter	Unit	Cell 1	Cell 2	Cell3
		T0	T0	T0
CPICH_Ec/lor	dB	-10	-10	-10
PCCPCH_Ec/lor	dB	-12	-12	-12
SCH_Ec/lor	dB	-12	-12	-12
PICH_Ec/lor	dB	-15	-15	-15
DPCH_Ec/lor	dB	Note 1	N/A	N/A
OCNS_Ec/lor	dB	Note 2	-0.941	-0.941
\hat{I}_{or} / I_{oc}	dB	0	-Inf	-Inf
\hat{I}_{or} (Note 3)	dBm	-85	-Inf	-Inf
I_{oc}	dBm/3.84 MHz	-85		
CPICH_Ec/lo	dB	-13	-Inf	-Inf
Propagation Condition		AWGN		
Note 1: The DPCH level is controlled by the power control loop.				
Note 2: The power of the OCNS channel that is added shall make the total power from the cell to be equal to I_{or} .				
Note 3: The nominal \hat{I}_{or} values, although not explicitly defined in 25.133 [2] are added here since they are implied and need to be identified so that the test equipment can be configured.				

The test parameters are given in table 8.6.1.2A.2 and 8.6.1.2A.3. In the measurement control information it is indicated to the UE that event-triggered reporting with Event 1A, 1C and 1B shall be used and the periodical reporting of the events is not applied. The test consists of four successive time periods, with a time duration of T1, T2, T3 and T4 respectively. In the initial condition before the time T1 only Cell1 is active.

Table 8.6.1.2A.2: General test parameters for Event triggered reporting of multiple neighbours in AWGN propagation conditions

Parameter	Unit	Value	Comment
DCH parameters		DL and UL Reference Measurement Channel 12.2 kbps	As specified in C.3.1 and C.2.1
Power Control		On	
Active cell		Cell 1	
Reporting range	dB	3	Applicable for event 1A and 1B
Hysteresis	dB	0	
W		1	Applicable for event 1A and 1B
Replacement activation threshold		0	Applicable for event 1C
Reporting deactivation threshold		0	Applicable for event 1A
Time to Trigger	ms	0	
Filter coefficient		0	
Monitored cell list size		32	NOTE: See Annex I for cell information
T1	S	10	
T2	S	10	
T3	S	5	
T4	S	10	

Table 8.6.1.2A.3: Cell specific test parameters for Event triggered reporting of multiple neighbours in AWGN propagation condition

Parameter	Unit	Cell 1				Cell 2				Cell3			
		T1	T2	T3	T4	T1	T2	T3	T4	T1	T2	T3	T4
CPICH_Ec/Ior	dB	-10				-10				-10			
PCCPCH_Ec/Ior	dB	-12				-12				-12			
SCH_Ec/Ior	dB	-12				-12				-12			
PICH_Ec/Ior	dB	-15				-15				-15			
DPCH_Ec/Ior	dB	Note 1				N/A				N/A			
OCNS_Ec/Ior	dB	Note 2				-0.941				-0.941			
\hat{I}_{or}/I_{oc}	dB	6.97	6.93	5.97	6.12	-Inf	9.43	6.97	7.62	5.97	6.93	-Inf	5.62
\hat{I}_{or} (Note 3)	dBm	-78.03	-78.07	-79.03	-78.88	-Inf	-75.57	-78.03	-77.38	-79.03	-78.07	-Inf	-79.38
I_{oc}	dBm/3.84 MHz	-85											
CPICH_Ec/Io	dB	-13	-16	-14	-15.5	-Inf	-13.5	-13	-14	-14	-16	-Inf	-16
Propagation Condition		AWGN											
Note 1: The DPCH level is controlled by the power control loop.													
Note 2: The power of the OCNS channel that is added shall make the total power from the cell to be equal to I_{or} .													
Note 3: The nominal \hat{I}_{or} values, although not explicitly defined in 25.133 [2] are added here since they are implied and need to be identified so that the test equipment can be configured.													

8.6.1.2A.4.2 Procedure

- 1) The RF parameters are set up according to T0 in table 8.6.1.2A.4.
- 2) The UE is switched on.
- 3) A call is set up according to the test procedure specified in TS 34.108 [3] sub clause 7.3.2. The scrambling code is set to Cell2 and Cell3.
- 4) SS shall transmit the initial MEASUREMENT CONTROL message.
- 5) 5 seconds after step4 has completed, the SS shall switch the power settings for T0 to T1 in table 8.6.1.2A.5.
- 6) UE shall transmit a MEASUREMENT REPORT message for Cell 3 triggered by event 1A. The measurement reporting delay from the beginning of T1 shall be less than 880 ms. If the UE fails to report the event within the required delay, then the counter event1A_failure is increased by one. If the reporting delay for this event is within the required limit, the counter event1A_success is increased by one.

- 7) UE may transmit a MEASUREMENT REPORT message for Cell 3 triggered by event 1C. In case it doesn't this shall not be considered as a failure.
- 8) After 10 seconds from the beginning of T1, the SS shall switch the power settings from T1 to T2 in table 8.6.1.2A.5.
- 9) UE shall transmit a MEASUREMENT REPORT message for Cell 2 triggered by event 1C. The measurement reporting delay from the beginning of T2 shall be less than 880 ms. If the UE fails to report the event within the required delay, then the counter event1C_failure is increased by one. If the reporting delay for this event is within the required limit, the counter event1C_success is increased by one.
- 10) UE shall transmit a MEASUREMENT REPORT message for Cell 2 triggered by event 1A. The measurement reporting delay from the beginning of T2 shall be less than 880 ms. If the UE fails to report the event within the required delay, then the counter event1A_failure is increased by one. If the reporting delay for this event is within the required limit, the counter event1A_success is increased by one.
- 11) UE may transmit a MEASUREMENT REPORT message for Cell 3 triggered by event 1C. In case it doesn't this shall not be considered as a failure.
- 12) SS shall transmit the measurement control message to disable event 1C reporting
- 13) After 10 seconds from the beginning of T2, the SS shall switch the power settings from T2 to T3 in table 8.6.1.2A.5.
- 14) UE shall transmit a MEASUREMENT REPORT message for Cell 3 triggered by event 1B. The measurement reporting delay from the beginning of T3 shall be less than 280 ms. If the UE fails to report the event within the required delay, then the counter event1B_failure is increased by one. If the reporting delay for this event is within the required limit, the counter event1B_success is increased by one.
- 15) After 5 seconds from the beginning of T3, the SS shall switch the power settings from T3 to T4 in table 8.6.1.2A.5.
- 16) UE shall transmit a MEASUREMENT REPORT message for Cell 3 triggered by event 1A. The measurement reporting delay from the beginning of T4 shall be less than 280 ms. If the UE fails to report the event within the required delay, then the counter event1A_failure is increased by one. If the reporting delay for this event is within the required limit, the counter event1A_success is increased by one.
- 17) Void
- 18) Void
- 19) After the SS receive the MEASUREMENT REPORT message in step 16) or 10 seconds after the beginning of T4, the SS shall transmit a RRC Connection Release message to make the UE to transit to idle mode.
- 20) SS shall set the new primary code group and primary code on Cell2 and Cell3. Three different primary code groups and primary codes according to Annex I are used to turn on Cell2 and Cell3. Previous timing information of Cell 2 and Cell3 are invalid in the UE. The RF parameters are set up according to T0 in table 8.6.1.2A.4.
- 21) Repeat steps 3-20 until the confidence level according to annex F.6.2 is achieved. If one counter reaches the pass criterion, this counter is stopped and the remaining counters are continued. For the overall outcome of the test to be considered a pass, the counters for 1A events and for 1B and for 1C events shall independently indicate a pass result. The test is stopped immediately and the test is considered to be a fail, if any counter reaches an early fail criterion.

Specific Message Contents

All messages indicated above shall use the same content as described in the default message content in clause 9 of 34.108 [3], with the following exceptions:

Initial MEASUREMENT CONTROL message:

Information Element/Group name	Value/Remark
Message Type (10.2.17)	
UE information elements -RRC transaction identifier -Integrity check info -message authentication code -RRC message sequence number	0 SS calculates the value of MAC-I for this message and writes to this IE. The first/ leftmost bit of the bit string contains the most significant bit of the MAC-I. SS provides the value of this IE, from its internal counter.
Measurement Information elements -Measurement Identity -Measurement Command (10.3.7.46) -Measurement Reporting Mode (10.3.7.49) -Measurement Report Transfer Mode -Periodical Reporting / Event Trigger Reporting Mode -Additional measurements list (10.3.7.1)	1 Modify AM RLC Event trigger Not Present
-CHOICE <i>Measurement type</i> -Intra-frequency measurement (10.3.7.36) -Intra-frequency measurement objects list (10.3.7.33) -Intra-frequency measurement quantity (10.3.7.38) -Filter coefficient (10.3.7.9) -CHOICE mode -Measurement quantity -Intra-frequency reporting quantity (10.3.7.41)	Intra-frequency measurement Not Present 0 FDD CPICH_Ec/N0
-Reporting quantities for active set cells (10.3.7.5) -Cell synchronisation information reporting indicator -Cell Identity reporting indicator -CHOICE mode -CPICH Ec/N0 reporting indicator -CPICH RSCP reporting indicator -Pathloss reporting indicator	TRUE (Note 1) TRUE FDD TRUE TRUE FALSE
-Reporting quantities for monitored set cells (10.3.7.5) -Cell synchronisation information reporting indicator -Cell Identity reporting indicator -CHOICE mode -CPICH Ec/N0 reporting indicator -CPICH RSCP reporting indicator -Pathloss reporting indicator	TRUE (Note 1) TRUE FDD TRUE TRUE FALSE
-Reporting quantities for detected set cells (10.3.7.5)	Not Present
-Reporting cell status (10.3.7.61) -Measurement validity (10.3.7.51) -CHOICE report criteria -Intra-frequency measurement reporting criteria (10.3.7.39) -Parameters required for each event	Not Present Not Present Intra-frequency measurement reporting criteria 3
-Intra-frequency event identity -Triggering condition 2 -Reporting Range Constant -Cells forbidden to affect Reporting Range -W -Hysteresis -Threshold used frequency -Reporting deactivation threshold -Replacement activation threshold -Time to trigger -Amount of reporting -Reporting interval -Reporting cell status - CHOICE reported cell - Maximum number of reported cells	Event 1A Monitored set cells 3 dB Not Present 1.0 0 dB Not Present 0 Not Present 0 ms Infinity 0 ms (Note 2) Report cell within active set and/or monitored set cells on used frequency 3
-Intra-frequency event identity -Triggering condition 1 -Reporting Range Constant	Event 1B Active set cells and monitored set cells 3 dB

Information Element/Group name	Value/Remark
-Cells forbidden to affect Reporting Range -W -Hysteresis -Threshold used frequency -Reporting deactivation threshold -Replacement activation threshold -Time to trigger -Amount of reporting -Reporting interval -Reporting cell status - CHOICE reported cell - Maximum number of reported cells	Not Present 1.0 0 dB Not Present Not Present Not Present 0 ms Not Present 0 ms (Note 2) Report cell within active set and/or monitored set cells on used frequency 3
-Intra-frequency event identity -Reporting Range Constant -Cells forbidden to affect Reporting Range -W -Hysteresis -Threshold used frequency -Reporting deactivation threshold -Replacement activation threshold -Time to trigger -Amount of reporting -Reporting interval -Reporting cell status - CHOICE reported cell - Maximum number of reported cells	Event 1C Not present Not Present Not present 0 dB Not Present Not present 0 0 ms Infinity 0 ms (Note 2) Report cell within active set and/or monitored set cells on used frequency 3
Physical channel information elements -DPCH compressed mode status info (10.3.6.34)	Not Present
NOTE 1: The SFN-CFN observed time difference is calculated from the OFF and Tm parameters contained in the IE "Cell synchronisation information", TS 25.331, clause 10.3.7.6. According to TS 25.331, 8.6.7.7, this IE is included in MEASUREMENT REPORT if IE "Cell synchronisation information reporting indicator" in IE "Cell reporting quantities" TS 25.331, clause 10.3.7.5 is set to TRUE in MEASUREMENT CONTROL.	
NOTE 2: Reporting interval = 0 ms means no periodical reporting.	

MEASUREMENT CONTROL message to disable event 1C reporting:

Information Element/Group name	Value/Remark
Message Type (10.2.17)	
UE information elements	
-RRC transaction identifier	0
-Integrity check info	
-message authentication code	SS calculates the value of MAC-I for this message and writes to this IE. The first/ leftmost bit of the bit string contains the most significant bit of the MAC-I.
-RRC message sequence number	SS provides the value of this IE, from its internal counter.
Measurement Information elements	
-Measurement Identity	1
-Measurement Command (10.3.7.46)	Modify
-Measurement Reporting Mode (10.3.7.49)	
-Measurement Report Transfer Mode	AM RLC
-Periodical Reporting / Event Trigger Reporting Mode	Event trigger
-Additional measurements list (10.3.7.1)	Not Present
-CHOICE <i>Measurement type</i>	Intra-frequency measurement
-Intra-frequency measurement (10.3.7.36)	
-Intra-frequency measurement objects list (10.3.7.33)	Not Present
-Intra-frequency measurement quantity (10.3.7.38)	
-Filter coefficient (10.3.7.9)	0
-CHOICE mode	FDD
-Measurement quantity	CPICH_Ec/N0
-Intra-frequency reporting quantity (10.3.7.41)	Not Present
-Reporting cell status (10.3.7.61)	Not Present
-Measurement validity (10.3.7.51)	Not Present
-CHOICE report criteria	Intra-frequency measurement reporting criteria
-Intra-frequency measurement reporting criteria (10.3.7.39)	
-Parameters required for each event	2
-Intra-frequency event identity	Event 1A
-Triggering condition 2	Monitored set cells
-Reporting Range Constant	3 dB
-Cells forbidden to affect Reporting Range	Not Present
-W	1.0
-Hysteresis	0 dB
-Threshold used frequency	Not Present
-Reporting deactivation threshold	0
-Replacement activation threshold	Not Present
-Time to trigger	0 ms
-Amount of reporting	Infinity
-Reporting interval	0 ms (Note 1)
-Reporting cell status	
- CHOICE reported cell	Report cell within active set and/or monitored set cells on used frequency
- Maximum number of reported cells	3
-Intra-frequency event identity	Event 1B
-Triggering condition 1	Active set cells and monitored set cells
-Reporting Range Constant	3 dB
-Cells forbidden to affect Reporting Range	Not Present
-W	1.0
-Hysteresis	0 dB
-Threshold used frequency	Not Present
-Reporting deactivation threshold	Not Present
-Replacement activation threshold	Not Present
-Time to trigger	0 ms
-Amount of reporting	Not Present
-Reporting interval	0 ms (Note 1)
-Reporting cell status	
- CHOICE reported cell	Report cell within active set and/or monitored set cells on used frequency
- Maximum number of reported cells	3
Physical channel information elements	
-DPCH compressed mode status info (10.3.6.34)	Not Present

Information Element/Group name	Value/Remark
NOTE 1: Reporting interval = 0 ms means no periodical reporting.	

MEASUREMENT REPORT message for Intra frequency test cases

This message is common for all intra frequency test cases is described in Annex I.

8.6.1.2A.5 Test requirements

For the test to pass, the total number of successful tests shall be at least 90%, of the cases with a confidence level of 95%. For the overall outcome of the test to be considered a pass, the counters for 1A events and for 1B events and for 1C events shall independently indicate a pass result.

Table 8.6.1.2A.4: Initial test requirements for Event triggered reporting of multiple neighbours in AWGN propagation conditions

Parameter	Unit	Cell 1	Cell 2	Cell3
		T0	T0	T0
CPICH_Ec/lor	dB	-9.3	-9.3	-9.3
PCCPCH_Ec/lor	dB	-11.3	-11.3	-11.3
SCH_Ec/lor	dB	-11.3	-11.3	-11.3
PICH_Ec/lor	dB	-14.3	-14.3	-14.3
DPCH_Ec/lor	dB	Note 1	N/A	N/A
OCNS_Ec/lor	dB	Note 2	-1.13	-1.13
\hat{I}_{or}/I_{oc}	dB	0	-Inf	-Inf
\hat{I}_{or}	dBm	-85	-Inf	-Inf
I_{oc}	dBm/3.84 MHz	-85		
CPICH_Ec/lor (Note 3)	dB	-12.3	-Inf	-Inf
Propagation Condition		AWGN		

Note 1: The DPCH level is controlled by the power control loop.
Note 2: The power of the OCNS channel that is added shall make the total power from the cell to be equal to I_{or} .
Note 3: These parameters are not directly settable, but are derived by calculation from the settable parameters.

Table 8.6.1.2A.5: Test requirements for Event triggered reporting of multiple neighbours in AWGN propagation condition

Parameter	Unit	Cell 1				Cell 2				Cell3			
		T1	T2	T3	T4	T1	T2	T3	T4	T1	T2	T3	T4
CPICH_Ec/lor	dB	-9.3				-9.3				-9.3			
PCCPCH_Ec/lor	dB	-11.3				-11.3				-11.3			
SCH_Ec/lor	dB	-11.3				-11.3				-11.3			
PICH_Ec/lor	dB	-14.3				-14.3				-14.3			
DPCH_Ec/lor	dB	Note 1				N/A				N/A			
OCNS_Ec/lor	dB	Note 2				-1.13				-1.13			
\hat{I}_{or}/I_{oc} (Note 3)	dB	7.0	6.9	6.0	6.1	-Inf	9.4	7.0	7.6	6.0	6.9	-Inf	5.6
\hat{I}_{or}	dBm	-78.0	-78.1	-79.0	-78.9	-Inf	-75.6	-78.0	-77.4	-79.0	-78.1	-Inf	-79.4
I_{oc}	dBm/3.84 MHz	-85											
CPICH_Ec/lor (Note 3)	dB	-12.3	-15.3	-13.3	-14.8	-Inf	-12.8	-12.3	-13.3	-13.3	-15.3	-Inf	-15.3
Propagation Condition		AWGN											

Note 1: The DPCH level is controlled by the power control loop.
Note 2: The power of the OCNS channel that is added shall make the total power from the cell to be equal to I_{or} .
Note 3: These parameters are not directly settable, but are derived by calculation from the settable parameters.

NOTE: If the above Test Requirement differs from the Minimum Requirement then the Test Tolerance applied for this test is non-zero. The Test Tolerance for this test is defined in clause F.2 and the explanation of how the Minimum Requirement has been relaxed by the Test Tolerance is given in clause F.4.

8.6.1.3 Event triggered reporting of two detectable neighbours in AWGN propagation condition (R99)

8.6.1.3.1 Definition and applicability

In the event triggered reporting period the measurement reporting delay is defined as the time between any event that will trigger a measurement report until the UE starts to transmit over the Uu interface. This requirement assumes that the measurement report is not delayed by other RRC signalling on the DCCH. This measurement reporting delay excludes a delay uncertainty resulted when inserting the measurement report to the TTI of the uplink DCCH . The delay uncertainty is twice the TTI of the uplink DCCH.

The requirements and this test apply to the Release 99 FDD UE.

8.6.1.3.2 Minimum requirements

The requirements are the same as in sub clause 8.6.1.1.2.

The normative reference for these requirements is TS 25.133 [2] clauses 8.1.2.2 and A.8.1.3.

8.6.1.3.3 Test purpose

To verify that the UE meets the minimum requirements.

8.6.1.3.4 Method of test

8.6.1.3.4.1 Initial conditions

Test environment: normal; see clauses G.2.1 and G.2.2.

Frequencies to be tested: mid range; see clause G.2.4.

The initial test parameters are given in table 8.6.1.3.1.

Table 8.6.1.3.1: Cell specific initial test parameters for Event triggered reporting of two detectable neighbours in AWGN propagation condition

Parameter	Unit	Cell 1	Cell 2	Cell3
		T0	T0	T0
CPICH_Ec/Ior	dB	-10	-10	-10
PCCPCH_Ec/Ior	dB	-12	-12	-12
SCH_Ec/Ior	dB	-12	-12	-12
PICH_Ec/Ior	dB	-15	-15	-15
DPCH_Ec/Ior	dB	-17	N/A	N/A
OCNS_Ec/Ior	dB	Note 1	-0.941	-0.941
\hat{I}_{or}/I_{oc}	dB	Note 2	-Inf	-Inf
\hat{I}_{or} (Note 3)	dBm	-79.13	-Inf	-Inf
I_{oc}	dBm/3.84 MHz	-85		
CPICH_Ec/Io	dB	-11	-Inf	-Inf
Propagation Condition		AWGN		
Note 1:	The DPCH level is controlled by the power control loop.			
Note 2:	The power of the OCNS channel that is added shall make the total power from the cell to be equal to Ior.			
Note 3:	The nominal \hat{I}_{or} values, although not explicitly defined in 25.133 [2] are added here since they are implied and need to be identified so that the test equipment can be configured.			

The test parameters are given in table 8.6.1.3.2 and 8.6.1.3.5. In the measurement control information it is indicated to the UE that event-triggered reporting with Event 1A and 1B shall be used and the periodical reporting of the events is not applied. CPICH Ec/Io and SFN-CFN observed time difference shall be reported together with Event 1A. The test consists of five successive time periods, with a time duration of T1, T2, T3, T4 and T5 respectively. In the initial condition before the time T1, defined as T0, only Cell1 is active.

Table 8.6.1.3.2: General test parameters for Event triggered reporting of two detectable neighbours in AWGN propagation condition

Parameter	Unit	Value	Comment
DCH parameters		DL and UL Reference Measurement Channel 12.2 kbps	As specified in C.3.1 and C.2.1
Power Control		On	
Active cell		Cell 1	
Reporting range	dB	3	Applicable for event 1A and 1B
Hysteresis	dB	0	
W		0	Applicable for event 1A and 1B
Reporting deactivation threshold		0	Applicable for event 1A
Time to Trigger	ms	0	
Filter coefficient		0	
Monitored cell list size		32	NOTE: See Annex I for cell information.
T1	s	10	
T2	s	10	
T3	s	1	
T4	s	10	
T5	s	10	

Table 8.6.1.3.3: Cell specific test parameters for Event triggered reporting of two detectable neighbours in AWGN propagation condition

Parameter	Unit	Cell 1					Cell 2					Cell3				
		T1	T2	T3	T4	T5	T1	T2	T3	T4	T5	T1	T2	T3	T4	T5
CPICH_Ec/I _{or}	dB	-10					-10					-10				
PCCPCH_Ec/I _{or}	dB	-12					-12					-12				
SCH_Ec/I _{or}	dB	-12					-12					-12				
PICH_Ec/I _{or}	dB	-15					-15					-15				
DPCH_Ec/I _{or}	dB	Note 1					N/A		Note 1			N/A				
OCNS_Ec/I _{or}	dB	Note 2					-0.941		Note 2			-0.941				
\hat{I}_{or}/I_{oc}	dB	14.55	28.51	14.45	28.51	-Inf	27.51		13.95	21.51	8.05	21.51		13.95	27.5	
\hat{I}_{or} (Note 3)	dBm	70.45	56.49	70.55	56.49	-Inf	-57.49		-71.05	-63.49	-76.95	-63.49		-71.05	-57.49	
I_{oc}	dBm/3.84 MHz	-85														
CPICH_Ec/I _o	dB	-11	-13	-14.5	-13	-Inf	-14.0		-15	-20	-17.5	-20		-15	-14	
Propagation Condition		AWGN														
<p>Note 1: The DPCH level is controlled by the power control loop</p> <p>Note 2: The power of the OCNS channel that is added shall make the total power from the cell to be equal to I_{or}</p> <p>Note 3: The nominal I_{or} values, although not explicitly defined in 25.133 [2] are added here since they are implied and need to be identified so that the test equipment can be configured.</p>																

8.6.1.3.4.2 Procedure

- 1) The RF parameters are set up according to T0 in table 8.6.1.3.4.
- 2) The UE is switched on.
- 3) A call is set up according to the test procedure specified in TS 34.108 [3] sub clause 7.3.2. The scrambling code is set to Cell2 and Cell3.
- 4) SS shall transmit a MEASUREMENT CONTROL message.
- 5) After 10 seconds from the beginning T0, the SS shall switch the power settings from T0 to T1 in table 8.6.1.3.5.
- 6) After a total of 10 seconds from the beginning of T1, the SS shall switch the power settings from T1 to T2.
- 7) UE shall transmit a MEASUREMENT REPORT message for Cell 2 triggered by event 1A. The measurement reporting delay from the beginning of T2 shall be less than 880 ms. If the UE fails to report the event within the required delay, then the counter event1A_failure is increased by one. If the reporting delay for this event is within the required limit, the counter event1A_success is increased by one.
- 8) During the time period T2, the SS shall, after the Event 1A triggered measurement is reported, send an Active Set Update command with activation time “start of T3” adding cell 2 to the active set. The Active Set Update message shall be sent to the UE so that the whole message is available at the UE at least the RRC procedure delay prior to the beginning of T3.
- 9) After 11 seconds from the beginning T2, the SS shall switch the power settings from T2 to T4.
- 10) UE shall transmit a MEASUREMENT REPORT message for Cell 3 triggered by event 1A. The measurement reporting delay from the beginning of T4 shall be less than 280 ms. If the UE fails to report the event within the required delay, then the counter event1A_failure is increased by one. If the reporting delay for this event is within the required limit, the counter event1A_success is increased by one.
- 11) After 10 seconds from the beginning T4, the SS shall switch the power settings from T4 to T5.
- 12) UE shall transmit a MEASUREMENT REPORT message for Cell 2 triggered by event 1B. The measurement reporting delay from the beginning of T5 shall be less than 280 ms. If the UE fails to report the event within the required delay, then the counter event1B_failure is increased by one. If the reporting delay for this event is within the required limit, the counter event1B_success is increased by one.
- 13) After the SS receive the MEASUREMENT REPORT message in step 12) or 10 seconds after the beginning of T5, the SS shall transmit a RRC Connection Release message to make the UE to transit to idle mode.
- 14) SS shall set the new primary code group and primary code on Cell2 and Cell3. Three different primary code groups and primary codes according to Annex I are used to turn on Cell2 and Cell3. Previous timing information of Cell 2 and Cell3 are invalid in the UE. The RF parameters are set up according to T0 in table 8.6.1.3.4.
- 15) Repeat steps 3-14 until the confidence level according to annex F.6.2 is achieved. If one counter reaches the pass criterion, this counter is stopped and the remaining counters are continued. For the overall outcome of the test to be considered a pass, the counters for 1A events and for 1B events shall independently indicate a pass result. The test is stopped immediately and the test is considered to be a fail, if any counter reaches an early fail criterion.

Specific Message Contents

All messages indicated above shall use the same content as described in the default message content in clause 9 of 34.108 [3], with the following exceptions:

MEASUREMENT CONTROL message:

Information Element/Group name	Value/Remark
Message Type (10.2.17)	
UE information elements	
-RRC transaction identifier	0
-Integrity check info	
-message authentication code	SS calculates the value of MAC-I for this message and writes to this IE. The first/ leftmost bit of the bit string contains the most significant bit of the MAC-I.
-RRC message sequence number	SS provides the value of this IE, from its internal counter.
Measurement Information elements	
-Measurement Identity	1
-Measurement Command (10.3.7.46)	Modify
-Measurement Reporting Mode (10.3.7.49)	
-Measurement Report Transfer Mode	AM RLC
-Periodical Reporting / Event Trigger Reporting Mode	Event trigger
-Additional measurements list (10.3.7.1)	Not Present
-CHOICE <i>Measurement type</i>	Intra-frequency measurement
-Intra-frequency measurement (10.3.7.36)	
-Intra-frequency measurement objects list (10.3.7.33)	Not Present
-Intra-frequency measurement quantity (10.3.7.38)	
-Filter coefficient (10.3.7.9)	0
-CHOICE mode	FDD
-Measurement quantity	CPICH_Ec/N0
-Intra-frequency reporting quantity (10.3.7.41)	
-Reporting quantities for active set cells (10.3.7.5)	
-Cell synchronisation information reporting indicator	TRUE (Note 1)
-Cell Identity reporting indicator	TRUE
-CHOICE mode	FDD
-CPICH Ec/N0 reporting indicator	TRUE
-CPICH RSCP reporting indicator	TRUE
-Pathloss reporting indicator	FALSE
-Reporting quantities for monitored set cells (10.3.7.5)	
-Cell synchronisation information reporting indicator	TRUE (Note 1)
-Cell Identity reporting indicator	TRUE
-CHOICE mode	FDD
-CPICH Ec/N0 reporting indicator	TRUE
-CPICH RSCP reporting indicator	TRUE
-Pathloss reporting indicator	FALSE
-Reporting quantities for detected set cells (10.3.7.5)	Not Present
-Reporting cell status (10.3.7.61)	Not Present
-Measurement validity (10.3.7.51)	Not Present
-CHOICE report criteria	Intra-frequency measurement reporting criteria
-Intra-frequency measurement reporting criteria (10.3.7.39)	
-Parameters required for each event	2
-Intra-frequency event identity	Event 1A
-Triggering condition 2	Monitored set cells
-Reporting Range Constant	3 dB
-Cells forbidden to affect Reporting Range	Not Present
-W	0
-Hysteresis	0 dB
-Threshold used frequency	Not Present
-Reporting deactivation threshold	0
-Replacement activation threshold	Not Present
-Time to trigger	0 ms
-Amount of reporting	Infinity
-Reporting interval	0 ms (Note 2)
-Reporting cell status	
- CHOICE reported cell	Report cell within active set and/or monitored set cells on used frequency
- Maximum number of reported cells	3
-Intra-frequency event identity	Event 1B
-Triggering condition 1	Active set cells
-Reporting Range Constant	3 dB

Information Element/Group name	Value/Remark
-Cells forbidden to affect Reporting Range	Not Present
-W	0
-Hysteresis	0 dB
-Threshold used frequency	Not Present
-Reporting deactivation threshold	Not Present
-Replacement activation threshold	Not Present
-Time to trigger	0 ms
-Amount of reporting	Not Present
-Reporting interval	0 ms (Note 2)
-Reporting cell status	
- CHOICE reported cell	Report cell within active set and/or monitored set cells on used frequency
- Maximum number of reported cells	3
Physical channel information elements	
-DPCH compressed mode status info (10.3.6.34)	Not Present
NOTE 1: The SFN-CFN observed time difference is calculated from the OFF and Tm parameters contained in the IE "Cell synchronisation information", TS 25.331, clause 10.3.7.6. According to TS 25.331, 8.6.7.7, this IE is included in MEASUREMENT REPORT if IE "Cell synchronisation information reporting indicator" in IE "Cell reporting quantities" TS 25.331, clause 10.3.7.5 is set to TRUE in MEASUREMENT CONTROL.	
NOTE 2: Reporting interval = 0 ms means no periodical reporting.	

MEASUREMENT REPORT message for Intra frequency test cases

This message is common for all intra frequency test cases is described in Annex I.

8.6.1.3.5 Test requirements

For the test to pass, the total number of successful tests shall be at least 90% of the cases with a confidence level of 95%. For the overall outcome of the test to be considered a pass, the counters for 1A events and for 1B events shall independently indicate a pass result.

Table 8.6.1.3.4: Initial test parameters for Event triggered reporting of two detectable neighbours in AWGN propagation condition

Parameter	Unit	Cell 1	Cell 2	Cell3
		T0	T0	T0
CPICH_Ec/Ior	dB	-9.60	-9.60	-9.60
PCCPCH_Ec/Ior	dB	-11.60	-11.60	-11.60
SCH_Ec/Ior	dB	-11.60	-11.60	-11.60
PICH_Ec/Ior	dB	-14.60	-14.60	-14.60
DPCH_Ec/Ior	dB	Note 1	N/A	N/A
OCNS_Ec/Ior	dB	Note 2	-1.04	-1.04
\hat{I}_{or}/I_{oc} (Note 3)	dB	5.90	-Inf	-Inf
\hat{I}_{or}	dBm	-79.10	-Inf	-Inf
I_{oc}	dBm/3.84 MHz		-85	
CPICH_Ec/Io (Note 3)	dB	-10.49	-Inf	-Inf
Propagation Condition		AWGN		
Note 1: The DPCH level is controlled by the power control loop.				
Note 2: The power of the OCNS channel that is added shall make the total power from the cell to be equal to Ior.				
Note 3: These parameters are not directly settable, but are derived by calculation from the settable parameters.				

Table 8.6.1.3.5: Test parameters for Event triggered reporting of two detectable neighbours in AWGN propagation condition

Parameter	Unit	Cell 1					Cell 2					Cell3				
		T1	T2	T3	T4	T5	T1	T2	T3	T4	T5	T1	T2	T3	T4	T5
CPICH_Ec/lor	dB	-960					-9.60					-9.60				
PCCPCH_Ec/lor	dB	-11.60					-11.60					-11.60				
SCH_Ec/lor	dB	-11.60					-11.60					-11.60				
PICH_Ec/lor	dB	-14.60					-14.60					-14.60				
DPCH_Ec/lor	dB	Note 1					N/A		Note 1			N/A				
OCNS_Ec/lor	dB	Note 2					-1.04		Note 2			-1.04				
\hat{I}_{or}/I_{oc} (Note 3)	dB	14.6	28.50	14.5	28.5	-Inf	27.50		14.0	21.50	8.1	21.50	14.0	27.5		
\hat{I}_{or}	dBm	-70.40	-56.50	-70.50	-56.50	-Inf	-57.50		-71.00	-63.50	-76.90	-63.50	-71.00	-57.50		
I_{oc}	dBm/3.84 MHz	-85														
CPICH_Ec/lo (Note 3)	dB	-10.60	-12.60	-14.1	-12.60	-Inf	-13.60		-14.60	-19.60	-17.1	-19.60	-14.60	-13.60		
Propagation Condition		AWGN														
Note 1:	The DPCH level is controlled by the power control loop															
Note 2:	The power of the OCNS channel that is added shall make the total power from the cell to be equal to lor															
Note 3:	These parameters are not directly settable, but are derived by calculation from the settable parameters.															

NOTE: If the above Test Requirement differs from the Minimum Requirement then the Test Tolerance applied for this test is non-zero. The Test Tolerance for this test is defined in clause F.2 and the explanation of how the Minimum Requirement has been relaxed by the Test Tolerance is given in clause F.4.

8.6.1.3A Event triggered reporting of two detectable neighbours in AWGN propagation condition (Rel-4 and later)

8.6.1.3A.1 Definition and applicability

In the event triggered reporting period the measurement reporting delay is defined as the time between any event that will trigger a measurement report until the UE starts to transmit over the Uu interface. This requirement assumes that the measurement report is not delayed by other RRC signalling on the DCCH. This measurement reporting delay excludes a delay uncertainty resulted when inserting the measurement report to the TTI of the uplink DCCH. The delay uncertainty is twice the TTI of the uplink DCCH.

The requirements and this test apply to the Rel-4 and later FDD UE.

8.6.1.3A.2 Minimum requirements

The requirements are the same as in sub clause 8.6.1.1A.2.

The normative reference for these requirements is TS 25.133 [2] clauses 8.1.2.2 and A.8.1.3.

8.6.1.3A.3 Test purpose

To verify that the UE meets the minimum requirements.

8.6.1.3A.4 Method of test

8.6.1.3A.4.1 Initial conditions

Test environment: normal; see clauses G.2.1 and G.2.2.

Frequencies to be tested: mid range; see clause G.2.4.

The initial test parameters are given in table 8.6.1.3A.4.

Table 8.6.1.3A.1: Cell specific initial test parameters for Event triggered reporting of two detectable neighbours in AWGN propagation condition

Parameter	Unit	Cell 1	Cell 2	Cell3
		T0	T0	T0
CPICH_Ec/Ior	dB	-10	-10	-10
PCCPCH_Ec/Ior	dB	-12	-12	-12
SCH_Ec/Ior	dB	-12	-12	-12
PICH_Ec/Ior	dB	-15	-15	-15
DPCH_Ec/Ior	dB	Note 1	N/A	N/A
OCNS_Ec/Ior	dB	Note 2	-0.941	-0.941
\hat{I}_{or}/I_{oc}	dB	5.87	-Inf	-Inf
\hat{I}_{or} (Note 3)	dBm	-79.13	-Inf	-Inf
I_{oc}	dBm/3.84 MHz	-85		
CPICH_Ec/Io	dB	-11	-Inf	-Inf
Propagation Condition		AWGN		
Note 1:	The DPCH level is controlled by the power control loop.			
Note 2:	The power of the OCNS channel that is added shall make the total power from the cell to be equal to I_{or} .			
Note 3:	The nominal \hat{I}_{or} values, although not explicitly defined in 25.133 [2] are added here since they are implied and need to be identified so that the test equipment can be configured.			

The test parameters are given in table 8.6.1.3A.2 and 8.6.1.3A.5. In the measurement control information it is indicated to the UE that event-triggered reporting with Event 1A and 1B shall be used and the periodical reporting of the events is not applied. The test consists of four successive time periods, with a time duration of T1, T2, T3 and T4 respectively. In the initial condition before the time T1 only Cell1 is active.

Table 8.6.1.3A.2: General test parameters for Event triggered reporting of two detectable neighbours in AWGN propagation condition

Parameter	Unit	Value	Comment
DCH parameters		DL and UL Reference Measurement Channel 12.2 kbps	As specified in C.3.1 and C.2.1
Power Control		On	
Active cell		Cell 1	
Reporting range	dB	3	Applicable for event 1A and 1B
Hysteresis	dB	0	
W		1	Applicable for event 1A and 1B
Reporting deactivation threshold		0	Applicable for event 1A
Time to Trigger	Ms	0	
Filter coefficient		0	
Monitored cell list size		32	NOTE: See Annex I for cell information.
T1	S	10	
T2	S	10	
T3	S	10	
T4	S	10	

Table 8.6.1.3A.3: Cell specific test parameters for Event triggered reporting of two detectable neighbours in AWGN propagation condition

Parameter	Unit	Cell 1				Cell 2				Cell3			
		T1	T2	T3	T4	T1	T2	T3	T4	T1	T2	T3	T4
CPICH_Ec/I _{or}	dB		-10				-10				-10		
PCCPCH_Ec/I _{or}	dB		-12				-12				-12		
SCH_Ec/I _{or}	dB		-12				-12				-12		
PICH_Ec/I _{or}	dB		-15				-15				-15		
DPCH_Ec/I _{or}	dB	Note 1				N/A				N/A			
OCNS_Ec/I _{or}	dB	Note 2				-0.941				-0.941			
\hat{I}_{or}/I_{oc}	dB	14.55	28.51	14.45	28.51	-Inf	27.51	13.95	21.51	8.05	21.51	13.95	27.51
\hat{I}_{or} (Note 3)	dBm	-70.45	-56.49	-70.55	-56.49	-Inf	-57.49	-71.05	-63.49	-76.95	-63.49	-71.05	-57.49
I_{oc}	dBm/3.8 4 MHz	-85											
CPICH_Ec/I _o	dB	-11	-13	-14.5	-13	-Inf	-14.0	-15	-20	-17.5	-20	-15	-14
Propagation Condition		AWGN											
Note 1: The DPCH level is controlled by the power control loop													
Note 2: The power of the OCNS channel that is added shall make the total power from the cell to be equal to I_{or} .													
Note 3: The nominal I _{or} values, although not explicitly defined in 25.133 [2] are added here since they are implied and need to be identified so that the test equipment can be configured.													

8.6.1.3A.4.2 Procedure

- 1) The RF parameters are set up according to T0 in table 8.6.1.3A.4.
- 2) The UE is switched on.
- 3) A call is set up according to the test procedure specified in TS 34.108 [3] sub clause 7.3.2. The scrambling code is set to Cell2 and Cell3.
- 4) SS shall transmit a MEASUREMENT CONTROL message.
- 5) After 10 seconds from the beginning T0, the SS shall switch the power settings from T0 to T1 in 8.6.1.3A.5.
- 6) After a total of 10 seconds from the beginning of T1, the SS shall switch the power settings from T1 to T2.
- 7) UE shall transmit a MEASUREMENT REPORT message for Cell 2 triggered by event 1A. The measurement reporting delay from the beginning of T2 shall be less than 880 ms. If the UE fails to report the event within the required delay, then the counter event1A_failure is increased by one. If the reporting delay for this event is within the required limit, the counter event1A_success is increased by one.

- 8) After 10 seconds from the beginning T2, the SS shall switch the power settings from T2 to T3.
- 9) UE shall transmit a MEASUREMENT REPORT message for Cell 3 triggered by event 1A. The measurement reporting delay from the beginning of T3 shall be less than 280 ms. If the UE fails to report the event within the required delay, then the counter event1A_failure is increased by one. If the reporting delay for this event is within the required limit, counter event1A_success is increased by one.
- 10) After 10 seconds from the beginning T3, the SS shall switch the power settings from T3 to T4.
- 11) UE shall transmit a MEASUREMENT REPORT message for Cell 2 triggered by event 1B. The measurement reporting delay from the beginning of T4 shall be less than 280 ms. If the UE fails to report the event within the required delay, then the counter event1B_failure is increased by one. If the reporting delay for this event is within the required limit, the counter event1B_success is increased by one.
- 12) After the SS receive the MEASUREMENT REPORT message in step 11) or 10 seconds after the beginning of T4, the SS shall transmit a RRC Connection Release message to make the UE to transit to idle mode.
- 13) SS shall set the new primary code group and primary code on Cell2 and Cell3. Three different primary code groups and primary codes according to Annex I are used to turn on Cell2 and Cell3. Previous timing information of Cell 2 and Cell3 are invalid in the UE. The RF parameters are set up according to T0.
- 14) Repeat steps 3-13 used with three different primary code groups and primary codes on Cell2 and Cell3 until the confidence level according to annex F.6.2 is achieved. If one counter reaches the pass criterion, this counter is stopped and the remaining counters are continued. For the overall outcome of the test to be considered a pass, the counters for 1A events and for 1B events shall independently indicate a pass result. The test is stopped immediately and the test is considered to be a fail, if any counter reaches an early fail criterion.

Specific Message Contents

All messages indicated above shall use the same content as described in the default message content in clause 9 of 34.108 [3], with the following exceptions:

MEASUREMENT CONTROL message:

Information Element/Group name	Value/Remark
Message Type (10.2.17)	
UE information elements	
-RRC transaction identifier	0
-Integrity check info	
-message authentication code	SS calculates the value of MAC-I for this message and writes to this IE. The first/ leftmost bit of the bit string contains the most significant bit of the MAC-I.
-RRC message sequence number	SS provides the value of this IE, from its internal counter.
Measurement Information elements	
-Measurement Identity	1
-Measurement Command (10.3.7.46)	Modify
-Measurement Reporting Mode (10.3.7.49)	
-Measurement Report Transfer Mode	AM RLC
-Periodical Reporting / Event Trigger Reporting Mode	Event trigger
-Additional measurements list (10.3.7.1)	Not Present
-CHOICE <i>Measurement type</i>	Intra-frequency measurement
-Intra-frequency measurement (10.3.7.36)	
-Intra-frequency measurement objects list (10.3.7.33)	Not Present
-Intra-frequency measurement quantity (10.3.7.38)	
-Filter coefficient (10.3.7.9)	0
-CHOICE mode	FDD
-Measurement quantity	CPICH_Ec/N0
-Intra-frequency reporting quantity (10.3.7.41)	
-Reporting quantities for active set cells (10.3.7.5)	
-Cell synchronisation information reporting indicator	TRUE (Note 1)
-Cell Identity reporting indicator	TRUE
-CHOICE mode	FDD
-CPICH Ec/N0 reporting indicator	TRUE
-CPICH RSCP reporting indicator	TRUE
-Pathloss reporting indicator	FALSE
-Reporting quantities for monitored set cells (10.3.7.5)	
-Cell synchronisation information reporting indicator	TRUE (Note 1)
-Cell Identity reporting indicator	TRUE
-CHOICE mode	FDD
-CPICH Ec/N0 reporting indicator	TRUE
-CPICH RSCP reporting indicator	TRUE
-Pathloss reporting indicator	FALSE
-Reporting quantities for detected set cells (10.3.7.5)	Not Present
-Reporting cell status (10.3.7.61)	Not Present
-Measurement validity (10.3.7.51)	Not Present
-CHOICE report criteria	Intra-frequency measurement reporting criteria
-Intra-frequency measurement reporting criteria (10.3.7.39)	
-Parameters required for each event	2
-Intra-frequency event identity	Event 1A
-Triggering condition 2	Monitored set cells
-Reporting Range Constant	3 dB
-Cells forbidden to affect Reporting Range	Not Present
-W	1.0
-Hysteresis	0 dB
-Threshold used frequency	Not Present
-Reporting deactivation threshold	0
-Replacement activation threshold	Not Present
-Time to trigger	0 ms
-Amount of reporting	Infinity
-Reporting interval	0 ms (Note 2)
-Reporting cell status	
- CHOICE reported cell	Report cell within active set and/or monitored set cells on used frequency
- Maximum number of reported cells	3
-Intra-frequency event identity	Event 1B
-Triggering condition 1	Active set cells and monitored set cells
-Reporting Range Constant	3 dB

Information Element/Group name	Value/Remark
-Cells forbidden to affect Reporting Range	Not Present
-W	1.0
-Hysteresis	0 dB
-Threshold used frequency	Not Present
-Reporting deactivation threshold	Not Present
-Replacement activation threshold	Not Present
-Time to trigger	0 ms
-Amount of reporting	Not Present
-Reporting interval	0 ms (Note 2)
-Reporting cell status	
- CHOICE reported cell	Report cell within active set and/or monitored set cells on used frequency
- Maximum number of reported cells	3
Physical channel information elements	
-DPCH compressed mode status info (10.3.6.34)	Not Present
NOTE 1: The SFN-CFN observed time difference is calculated from the OFF and Tm parameters contained in the IE "Cell synchronisation information", TS 25.331, clause 10.3.7.6. According to TS 25.331, 8.6.7.7, this IE is included in MEASUREMENT REPORT if IE "Cell synchronisation information reporting indicator" in IE "Cell reporting quantities" TS 25.331, clause 10.3.7.5 is set to TRUE in MEASUREMENT CONTROL.	
NOTE 2: Reporting interval = 0 ms means no periodical reporting.	

MEASUREMENT REPORT message for Intra frequency test cases

This message is common for all intra frequency test cases is described in Annex I.

8.6.1.3A.5 Test requirements

For the test to pass, the total number of successful tests shall be at least 90% of the cases with a confidence level of 95%. For the overall outcome of the test to be considered a pass, the counters for 1A events and for 1B events shall independently indicate a pass result.

Table 8.6.1.3A.4: Initial test parameters for Event triggered reporting of two detectable neighbours in AWGN propagation condition

Parameter	Unit	Cell 1	Cell 2	Cell3
		T0	T0	T0
CPICH_Ec/Ior	dB	-9.60	-9.60	-9.60
PCCPCH_Ec/Ior	dB	-11.60	-11.60	-11.60
SCH_Ec/Ior	dB	-11.60	-11.60	-11.60
PICH_Ec/Ior	dB	-14.60	-14.60	-14.60
DPCH_Ec/Ior	dB	Note 1	N/A	N/A
OCNS_Ec/Ior	dB	Note 2	-1.04	-1.04
\hat{I}_{or}/I_{oc} (Note 3)	dB	5.90	-Inf	-Inf
\hat{I}_{or}	dBm	-79.10	-Inf	-Inf
I_{oc}	dBm/3.84 MHz		-85	
CPICH_Ec/Io (Note 3)	dB	-10.59	-Inf	-Inf
Propagation Condition		AWGN		
Note 1: The DPCH level is controlled by the power control loop				
Note 2: The power of the OCNS channel that is added shall make the total power from the cell to be equal to I_{or} .				
Note 3: These parameters are not directly settable, but are derived by calculation from the settable parameters.				

Table 8.6.1.3A.5: Test parameters for Event triggered reporting of two detectable neighbours in AWGN propagation condition

Parameter	Unit	Cell 1				Cell 2				Cell3			
		T1	T2	T3	T4	T1	T2	T3	T4	T1	T2	T3	T4
CPICH_Ec/I _{or}	dB	-9.60				-9.60				-9.60			
PCCPCH_Ec/I _{or}	dB	-11.60				-11.60				-11.60			
SCH_Ec/I _{or}	dB	-11.60				-11.60				-11.60			
PICH_Ec/I _{or}	dB	-14.60				-14.60				-14.60			
DPCH_Ec/I _{or}	dB	Note 1				N/A				N/A			
OCNS_Ec/I _{or}	dB	Note 2				-1.04				-1.04			
\hat{I}_{or}/I_{oc} (Note 3)	dB	14.60	28.50	14.50	28.50	-Inf	27.50	14.0	21.50	8.10	21.50	14.0	27.50
\hat{I}_{or}	dBm	-70.40	-56.50	-70.50	-56.50	-Inf	-57.50	-71.00	-63.50	-76.90	-63.50	-71.00	-57.50
I_{oc}	dBm/3.8 4 MHz	-85											
CPICH_Ec/I _o (Note 3)	dB	-10.60	-12.60	-14.10	-12.60	-Inf	-13.60	-14.60	-19.60	-17.10	-19.60	-14.60	-13.60
Propagation Condition		AWGN											
Note 1: The DPCH level is controlled by the power control loop.													
Note 2: The power of the OCNS channel that is added shall make the total power from the cell to be equal to I_{or} .													
Note 3: These parameters are not directly settable, but are derived by calculation from the settable parameters.													

NOTE: If the above Test Requirement differs from the Minimum Requirement then the Test Tolerance applied for this test is non-zero. The Test Tolerance for this test is defined in clause F.2 and the explanation of how the Minimum Requirement has been relaxed by the Test Tolerance is given in clause F.4.

8.6.1.4 Void

8.6.1.4A Correct reporting of neighbours in fading propagation condition (Rel-4 and later)

8.6.1.4A.1 Definition and applicability

In the event triggered reporting period the measurement reporting delay is defined as the time between any event that will trigger a measurement report until the UE starts to transmit over the Uu interface. This requirement assumes that the measurement report is not delayed by other RRC signalling on the DCCH. This measurement reporting delay excludes a delay uncertainty resulted when inserting the measurement report to the TTI of the uplink DCCH. The delay uncertainty is twice the TTI of the uplink DCCH.

The requirements and this test apply to the Release 4 and later FDD UE.

8.6.1.4A.2 Minimum requirements

The requirements are the same as in sub clause 8.6.1.1A.2.

The normative reference for these requirements is TS 25.133 [2] clauses 8.1.2.2 and A.8.1.4.

8.6.1.4A.3 Test purpose

To verify that the UE meets the minimum requirements and also verify that the UE performs sufficient layer 1 filtering of the measurements. The test is performed in fading propagation conditions.

8.6.1.4A.4 Method of test

8.6.1.4A.4.1 Initial conditions

Test environment: normal; see clauses G.2.1 and G.2.2.

Frequencies to be tested: mid range; see clause G.2.4.

The test parameters are given in table 8.6.1.4A.1 and 8.6.1.4A.2. In the measurement control information it is indicated to the UE that event-triggered reporting with Event 1A and Event 1B shall be used. The test consists of two successive time periods, each with time duration of T1 and T2 respectively.

The TTI of the uplink DCCH shall be 20ms.

Table 8.6.1.4A.1: General test parameters for correct reporting of neighbours in fading propagation condition

Parameter	Unit	Value	Comment
DCH parameters		DL and UL Reference Measurement Channel 12.2 kbps	As specified in C.3.1 and C.2.1
Power Control		On	
Active cell		Cell 1	
Reporting range	dB	0	Applicable for event 1A and 1B
Hysteresis	dB	0	
W		1	Applicable for event 1A and 1B
Reporting deactivation threshold		0	Applicable for event 1A
Time to Trigger	ms	120	
Filter coefficient		0	
Monitored cell list size		24	Signalled before time T1. NOTE: See Annex I for cell information.
T1	s	200	
T2	s	201	

Table 8.6.1.4A.2: Cell specific test parameters for correct reporting of neighbours in fading propagation condition

Parameter	Unit	Cell 1		Cell 2	
		T1	T2	T1	T2
CPICH_Ec/lor	dB	-10	-10	-10	-10
PCCPCH_Ec/lor	dB	-12	-12	-12	-12
SCH_Ec/lor	dB	-12	-12	-12	-12
PICH_Ec/lor	dB	-15	-15	-15	-15
DPCH_Ec/lor	dB	Note 1	Note 1	N/A	N/A
OCNS_Ec/lor	dB	Note 2	Note 2	-0.941	-0.941
\hat{I}_{or}/I_{oc}	dB	7.29	3.29	3.29	7.29
\hat{I}_{or} (Note 3)	dBm	-62.71	-66.71	-66.71	-62.71
I_{oc}	dBm/3.84 MHz	-70			
CPICH_Ec/lo	dB	-12	-16	-16	-12
Propagation Condition	Case 5 as specified in table D.2.2.1				
Note 1: The DPCH level is controlled by the power control loop. Note 2: The power of the OCNS channel that is added shall make the total power from the cell to be equal to I_{or} . Note 3: The nominal I_{or} values, although not explicitly defined in 25.133 [2] are added here since they are implied and need to be identified so that the test equipment can be configured.					

8.6.1.4A.4.2 Procedure

- 1) The RF parameters are set up according to T1.
- 2) The UE is switched on.
- 3) A call is set up in AWGN conditions, according to the test procedure specified in TS 34.108 [3] sub clause 7.3.2. The scrambling code is set to Cell2.
- 4) SS shall transmit a MEASUREMENT CONTROL message.
- 5) 5 seconds after step4 has completed, the fading simulator is switched on, configured with the settings in table 8.6.1.4A.3 at the beginning of T1.

- 6) UE may start to transmit MEASUREMENT REPORT messages triggered by event 1A.
- 7) SS shall count the reports. The number of received event 1A reports shall be less than 60. If the SS receives 60 or greater event 1A reports, then a failure is recorded. If the SS receives number of event 1A reports within the required limit, the number of successful tests is increased by one.
- 8) After 200 seconds from the beginning of T1, the SS shall switch the power settings from T1 to T2.
- 9) UE may start to transmit MEASUREMENT REPORT messages triggered by event 1B.
- 10) During the first 1s of time period T2 no event reports shall be counted.
- 11) After the first 1s SS shall start counting the reports. The number of received event 1B reports shall be less than 60. If the SS receives number of event 1B reports within the required limit, the number of successful tests is increased by one.
- 12) After 201 seconds from the beginning of T2, the SS shall transmit a RRC Connection Release message to make the UE to transit to idle mode.
- 13) SS shall set the different previous primary code group and primary code on Cell2. Three different primary code groups and primary codes according to Annex I are used to turn on Cell2. Previous timing information of cell 2 is invalid in the UE. The RF parameters are set up according to T1.
- 14) Repeat steps 3-13 until the confidence level according to annex F.6.2 is achieved.

Specific Message Contents

All messages indicated above shall use the same content as described in the default message content in clause 9 of 34.108 [3], with the following exceptions:

MEASUREMENT CONTROL message:

Information Element/Group name	Value/Remark
Message Type (10.2.17)	
UE information elements	
-RRC transaction identifier	0
-Integrity check info	
-message authentication code	SS calculates the value of MAC-I for this message and writes to this IE. The first/ leftmost bit of the bit string contains the most significant bit of the MAC-I.
-RRC message sequence number	SS provides the value of this IE, from its internal counter.
Measurement Information elements	
-Measurement Identity	1
-Measurement Command (10.3.7.46)	Modify
-Measurement Reporting Mode (10.3.7.49)	
-Measurement Report Transfer Mode	AM RLC
-Periodical Reporting / Event Trigger Reporting Mode	Event trigger
-Additional measurements list (10.3.7.1)	Not Present
-CHOICE <i>Measurement type</i>	Intra-frequency measurement
-Intra-frequency measurement (10.3.7.36)	
-Intra-frequency measurement objects list (10.3.7.33)	Not Present
-Intra-frequency measurement quantity (10.3.7.38)	
-Filter coefficient (10.3.7.9)	0
-CHOICE mode	FDD
-Measurement quantity	CPICH_Ec/N0
-Intra-frequency reporting quantity (10.3.7.41)	
-Reporting quantities for active set cells (10.3.7.5)	
-Cell synchronisation information reporting indicator	TRUE (Note 1)
-Cell Identity reporting indicator	TRUE
-CHOICE mode	FDD
-CPICH Ec/N0 reporting indicator	TRUE
-CPICH RSCP reporting indicator	TRUE
-Pathloss reporting indicator	FALSE
-Reporting quantities for monitored set cells (10.3.7.5)	
-Cell synchronisation information reporting indicator	TRUE (Note 1)
-Cell Identity reporting indicator	TRUE
-CHOICE mode	FDD
-CPICH Ec/N0 reporting indicator	TRUE
-CPICH RSCP reporting indicator	TRUE
-Pathloss reporting indicator	FALSE
-Reporting quantities for detected set cells (10.3.7.5)	Not Present
-Reporting cell status (10.3.7.61)	Not Present
-Measurement validity (10.3.7.51)	Not Present
-CHOICE report criteria	Intra-frequency measurement reporting criteria
-Intra-frequency measurement reporting criteria (10.3.7.39)	
-Parameters required for each event	2
-Intra-frequency event identity	Event 1A
-Triggering condition 2	Active set cells and monitored set cells
-Reporting Range Constant	0 dB
-Cells forbidden to affect Reporting Range	Not Present
-W	1.0
-Hysteresis	0 dB
-Threshold used frequency	Not Present
-Reporting deactivation threshold	0
-Replacement activation threshold	Not Present
-Time to trigger	120 ms
-Amount of reporting	Infinity
-Reporting interval	0 ms (Note 2)
-Reporting cell status	
- CHOICE reported cell	Report cell within active set and/or monitored set cells on used frequency
- Maximum number of reported cells	3
-Intra-frequency event identity	Event 1B
-Triggering condition 1	Active set cells and monitored set cells
-Reporting Range Constant	0 dB

Information Element/Group name	Value/Remark
-Cells forbidden to affect Reporting Range	Not Present
-W	1.0
-Hysteresis	0 dB
-Threshold used frequency	Not Present
-Reporting deactivation threshold	Not Present
-Replacement activation threshold	Not Present
-Time to trigger	120 ms
-Amount of reporting	Not Present
-Reporting interval	0 ms (Note 2)
-Reporting cell status	
- CHOICE reported cell	Report cell within active set and/or monitored set cells on used frequency
- Maximum number of reported cells	3
Physical channel information elements	
-DPCH compressed mode status info (10.3.6.34)	Not Present
Note 1: The SFN-CFN observed time difference is calculated from the OFF and Tm parameters contained in the IE "Cell synchronisation information", TS 25.331, clause 10.3.7.6. According to TS 25.331, 8.6.7.7, this IE is included in MEASUREMENT REPORT if IE "Cell synchronisation information reporting indicator" in IE "Cell reporting quantities" TS 25.331, clause 10.3.7.5 is set to TRUE in MEASUREMENT CONTROL.	
Note 2: Reporting interval = 0 ms means no periodical reporting	

MEASUREMENT REPORT message for Intra frequency test cases

This message is common for all intra frequency test cases is described in Annex I.

8.6.1.4A.5 Test requirements

For the test to pass, the total number of successful tests shall be at least 90% of the cases with a confidence level of 95%. The number of successful tests shall be on an event level, i.e. the SS shall check every time first if the number of the event 1A events is within the required limit, and then, check if the number of the event 1B events is within the required limit.

Table 8.6.1.4A.3: Test requirements for correct reporting of neighbours in fading propagation condition

Parameter	Unit	Cell 1		Cell 2	
		T1	T2	T1	T2
CPICH_Ec/lor	dB	-9.30	-9.70	-9.70	-9.30
PCCPCH_Ec/lor	dB	-11.30	-11.70	-11.70	-11.30
SCH_Ec/lor	dB	-11.30	-11.70	-11.70	-11.30
PICH_Ec/lor	dB	-14.30	-14.70	-14.70	-14.30
DPCH_Ec/lor	dB	Note 1	Note 1	N/A	
OCNS_Ec/lor	dB	Note 2	Note 2	-1.02	-1.13
\hat{I}_{or}/I_{oc} (Note 3)	dB	7.30	3.30	3.30	7.30
\hat{I}_{or}	dBm	-62.70	-66.70	-66.70	-62.70
I_{oc}	dBm/3.84 MHz	-70			
CPICH_Ec/lor (Note 3)	dB	-11.30	-15.70	-15.70	-11.30
Propagation Condition	Case 5 as specified in table D.2.2.1				
Note 1: The DPCH level is controlled by the power control loop.					
Note 2: The power of the OCNS channel that is added shall make the total power from the cell to be equal to I_{or} .					
Note 3: These parameters are not directly settable, but are derived by calculation from the settable parameters.					

NOTE: If the above Test Requirement differs from the Minimum Requirement then the Test Tolerance applied for this test is non-zero. The Test Tolerance for this test is defined in clause F.2 and the explanation of how the Minimum Requirement has been relaxed by the Test Tolerance is given in clause F.4.

8.6.1.5 Event triggered reporting of multiple neighbour cells in Case 1 fading condition

8.6.1.5.1 Definition and applicability

In the event triggered reporting period the measurement reporting delay is defined as the time between any event that will trigger a measurement report until the UE starts to transmit over the Uu interface. This requirement assumes that the measurement report is not delayed by other RRC signalling on the DCCH. This measurement reporting delay excludes a delay uncertainty resulted when inserting the measurement report to the TTI of the uplink DCCH . The delay uncertainty is twice the TTI of the uplink DCCH.

The requirements and this test apply to the Release 5 and later FDD UE.

8.6.1.5.2 Minimum requirements

The requirements are the same as in sub clause 8.6.1.1A.2.

The normative reference for these requirements is TS 25.133 [2] clauses 8.1.2.2 and A.8.1.5.

8.6.1.5.3 Test purpose

To verify that the UE meets the minimum requirements. The test is performed in Case 1 fading propagation conditions.

8.6.1.5.4 Method of test

8.6.1.5.4.1 Initial conditions

Test environment: normal; see clauses G.2.1 and G.2.2.

Frequencies to be tested: mid range; see clause G.2.4.

The test parameters are given in table 8.6.1.5.1 and 8.6.1.5.2. In the measurement control information it is indicated to the UE that event-triggered reporting with Event 1A shall be used and “CFN-SFN-Observed Time Difference” shall be reported. The test consists of two successive time periods, each with time duration of T1 and T2 respectively. During time duration T1, the UE shall not have any timing information of invisible cells.

Table 8.6.1.5.1: General test parameters for event triggered reporting in multi-cell pedestrian fading propagation condition

Parameter	Unit	Value	Comment
DCH parameters		DL Reference Measurement Channel 12.2 kbps	As specified in TS 25.101 section A.3.1
Power Control		On	
Active cells		Cell2, Cell3, Cell4	
Hysteresis	dB	0	Applicable for event 1A
Time to Trigger	ms	0	Applicable for event 1A
Filter coefficient		0	Applicable for event 1A
Reporting range R_{1a}	dB	9	Applicable for event 1A
W		0	Applicable for event 1A
TriggeringCondition		activeSetAndMonitoredSetCells	Applicable for event 1A
Monitored cell list size		32	
T1	s	5	
T2	s	5	

Table 8.6.1.5.2: Cell specific test parameters for event triggered reporting in multi-cell pedestrian fading propagation condition

Parameter	Unit	Cell 1		Cell 2		Cell 3		Cell 4	
		T1	T2	T1	T2	T1	T2	T1	T2
UTRA RF Channel Number		Channel 1		Channel 1		Channel 1		Channel 1	
CPICH_Ec/lor	dB	-10		-10		-10		-10	
PCCPCH_Ec/lor	dB	-12		-12		-12		-12	
SCH_Ec/lor	dB	-12		-12		-12		-12	
PICH_Ec/lor	dB	-15		-15		-15		-15	
DPCH_Ec/lor	dB	n.a.		Note 1		Note 1		Note 1	
OCNS_Ec/lor	dB	-0.941		Note 2		Note 2		Note 2	
\hat{I}_{or}/I_{oc}	dB	$-\infty$	1.3	4.3	1.3	4.3	1.3	1.3	4.3
I_{oc}	dBm/3.84 MHz	-70							
Propagation Condition		Case 1 (3km/h) as specified in table D.2.2.1							
CPICH_Ec/lo	dB	$-\infty$	-17.6	-14.6	-17.6	-14.6	-17.6	-17.6	-14.6
$\frac{SCH - \hat{E}_{c,maxpath}}{I_o}$	dB	$-\infty$	-20.0	-17.0	-20.0	-17.0	-20.0	-20.0	-17.0
NOTE 1: The DPCH level is controlled by the power control loop. NOTE 2: The power of the OCNS channel that is added shall make the total power equal to I_{or} . NOTE 3: CPICH_Ec/lo and SCH_Ec_maxpath/lo levels have been calculated from other parameters for information purposes. They are not settable themselves.									

8.6.1.5.4.2 Procedure

- 1) The RF parameters are set up according to T1 in table 8.6.1.5.1.
- 2) The UE is switched on.
- 3) A call is set up with Cell 2 in AWGN conditions, according to the test procedure specified in TS 34.108 [3] sub clause 7.3.2. The scrambling codes are set to Cell1.
- 4) SS shall transmit a MEASUREMENT CONTROL message.
- 5) The fading simulator is switched on, configured with the settings in table 8.6.1.5.3. T1 starts.
- 6) During the time period T1, the SS shall send an Active Set Update command with activation time "start of T1" adding cell 3 to the active set. The Active Set Update message shall be sent to the UE so that the whole message is available at the UE at least the RRC procedure delay prior to the beginning of T1.
- 7) During the time period T1, the SS shall send an Active Set Update command with activation time "start of T1" adding cell 4 to the active set. The Active Set Update message shall be sent to the UE so that the whole message is available at the UE at least the RRC procedure delay prior to the beginning of T1.
- 8) After 5 seconds from the beginning of T1, the SS shall switch the power settings from T1 to T2 according to the parameters defined in table 8.6.1.5.3.
- 9) UE shall transmit a MEASUREMENT REPORT message for Cell 1 triggered by event 1A containing the CFN-SFN observe time difference between cell 1 and cell 2. The measurement reporting delay from the beginning of T2 shall be less than 880 ms. If the UE fails to report the event within the required delay, then the counter event1A_failure is increased by one. If the reporting delay for this event is within the required limit, the counter event1A_success is increased by one.
- 10) After the SS receives the MEASUREMENT REPORT message in step 9) or 5 seconds after the beginning of T2, the SS shall transmits a RRC Connection Release message to make the UE to transit to idle mode.
- 11) SS shall set the new primary code group and primary code on Cell 1. Three different primary code groups and primary codes according to Annex I are used to turn on Cell 1. Previous timing information of cell 1 is invalid in the UE. The RF parameters are set up according to T1 in table 8.6.1.5.3.

12) Repeat steps 3-11 according to Annex F.6.2 is achieved. If one counter reaches the pass criterion, this counter is stopped and the remaining counters are continued. For the overall outcome of the test to be considered a pass, the counters for 1A events shall independently indicate a pass result. The test is stopped immediately and the test is considered to be a fail, if any counter reaches an early fail criterion.

Specific Message Contents

All messages indicated above shall use the same content as described in the default message content in clause 9 of 34.108 [3], with the following exceptions:

MEASUREMENT CONTROL message:

Information Element/Group name	Value/Remark
Message Type (10.2.17)	
UE information elements	
-RRC transaction identifier	0
-Integrity check info	
-message authentication code	SS calculates the value of MAC-I for this message and writes to this IE. The first/ leftmost bit of the bit string contains the most significant bit of the MAC-I.
-RRC message sequence number	SS provides the value of this IE, from its internal counter.
Measurement Information elements	
-Measurement Identity	1
-Measurement Command (10.3.7.46)	Modify
-Measurement Reporting Mode (10.3.7.49)	
-Measurement Report Transfer Mode	AM RLC
-Periodical Reporting / Event Trigger Reporting Mode	Event trigger
-Additional measurements list (10.3.7.1)	Not Present
-CHOICE <i>Measurement type</i>	Intra-frequency measurement
-Intra-frequency measurement (10.3.7.36)	
-Intra-frequency measurement objects list (10.3.7.33)	Not Present
-Intra-frequency measurement quantity (10.3.7.38)	
-Filter coefficient (10.3.7.9)	0
-CHOICE mode	FDD
-Measurement quantity	CPICH_Ec/N0
-Intra-frequency reporting quantity (10.3.7.41)	
-Reporting quantities for active set cells (10.3.7.5)	
-Cell synchronisation information reporting indicator	TRUE (Note 1)
-Cell Identity reporting indicator	TRUE
-CHOICE mode	FDD
-CPICH Ec/N0 reporting indicator	TRUE
-CPICH RSCP reporting indicator	TRUE
-Pathloss reporting indicator	FALSE
-Reporting quantities for monitored set cells (10.3.7.5)	
-Cell synchronisation information reporting indicator	TRUE (Note 1)
-Cell Identity reporting indicator	TRUE
-CHOICE mode	FDD
-CPICH Ec/N0 reporting indicator	TRUE
-CPICH RSCP reporting indicator	TRUE
-Pathloss reporting indicator	FALSE
-Reporting quantities for detected set cells (10.3.7.5)	Not Present
-Reporting cell status (10.3.7.61)	Not Present
-Measurement validity (10.3.7.51)	Not Present
-CHOICE report criteria	Intra-frequency measurement reporting criteria
-Intra-frequency measurement reporting criteria (10.3.7.39)	
-Parameters required for each event	1
-Intra-frequency event identity	Event 1A
-Triggering condition 1	Active set cells and monitored set cells
-Reporting Range Constant	9 dB
-Cells forbidden to affect Reporting Range	Not Present
-W	0
-Hysteresis	0 dB
-Threshold used frequency	Not Present
-Reporting deactivation threshold	Not Present
-Replacement activation threshold	Not Present
-Time to trigger	0 ms
-Amount of reporting	Infinity
-Reporting interval	0 ms (Note 2)
-Reporting cell status	
- CHOICE reported cell	Report cell within active set and/or monitored set cells on used frequency
- Maximum number of reported cells	3
Physical channel information elements	
-DPCH compressed mode status info (10.3.6.34)	Not Present

Information Element/Group name	Value/Remark
Note 1:	The SFN-CFN observed time difference is calculated from the OFF and Tm parameters contained in the IE "Cell synchronisation information", TS 25.331, clause 10.3.7.6. According to TS 25.331, 8.6.7.7, this IE is included in MEASUREMENT REPORT if IE "Cell synchronisation information reporting indicator" in IE "Cell reporting quantities" TS 25.331, clause 10.3.7.5 is set to TRUE in MEASUREMENT CONTROL.
Note 2:	Reporting interval = 0 ms means no periodical reporting

MEASUREMENT REPORT message for Intra frequency test cases

This message is common for all intra frequency test cases is described in Annex I.

8.6.1.5.5 Test requirements

For the test to pass, the total number of successful tests shall be at least 90% of the cases with a confidence level of 95%. For the overall outcome of the test to be considered a pass, the counters for Event 1A shall independently indicate a pass result.

Table 8.6.1.5.3: Test requirements for Cell specific test parameters for event triggered reporting in multi-cell pedestrian fading propagation condition

Parameter	Unit	Cell 1		Cell 2		Cell 3		Cell 4	
		T1	T2	T1	T2	T1	T2	T1	T2
UTRA RF Channel Number		Channel 1		Channel 1		Channel 1		Channel 1	
CPICH_Ec/Ior	dB	-9.3		-9.3		-9.3		-9.3	
PCCPCH_Ec/Ior	dB	-11.3		-11.3		-11.3		-11.3	
SCH_Ec/Ior	dB	-11.3		-11.3		-11.3		-11.3	
PICH_Ec/Ior	dB	-14.3		-14.3		-14.3		-14.3	
DPCH_Ec/Ior	dB	n.a.		Note 1		Note 1		Note 1	
OCNS_Ec/Ior	dB	-1.13	-1.19	Note 2		Note 2		Note 2	
\hat{I}_{or}/I_{oc}	dB	∞	1.2	4.2	1.2	4.2	1.2	1.2	4.2
I_{oc}	dBm/3.84 MHz	-70							
Propagation Condition		Case 1 (3km/h) as specified in table D.2.2.1							
CPICH_Ec/Io	dB	∞	-16.9	-13.9	-16.9	-13.9	-16.9	-16.9	-13.9
	dB	∞	-19.3	-16.3	-19.3	-16.3	-19.3	-19.3	-16.3
NOTE 1: The DPCH level is controlled by the power control loop.									
NOTE 2: The power of the OCNS channel that is added shall make the total power equal to I_{or} .									
NOTE 3: CPICH_Ec/Io and SCH_Ec_maxpath/Io levels have been calculated from other parameters for information purposes. They are not settable themselves.									

NOTE: If the above Test Requirement differs from the Minimum Requirement then the Test Tolerance applied for this test is non-zero. The Test Tolerance for this test is defined in clause F.2 and the explanation of how the Minimum Requirement has been relaxed by the Test Tolerance is given in clause F.4.

8.6.1.6 Event triggered reporting of multiple neighbour cells in Case 3 fading condition

8.6.1.6.1 Definition and applicability

In the event triggered reporting period the measurement reporting delay is defined as the time between any event that will trigger a measurement report until the UE starts to transmit over the Uu interface. This requirement assumes that the measurement report is not delayed by other RRC signalling on the DCCH. This measurement reporting delay excludes a delay uncertainty resulted when inserting the measurement report to the TTI of the uplink DCCH. The delay uncertainty is twice the TTI of the uplink DCCH.

The requirements and this test apply to the Release 5 and later FDD UE.

8.6.1.6.2 Minimum requirements

The requirements are the same as in sub clause 8.6.1.1A.2.

The normative reference for these requirements is TS 25.133 [2] clauses 8.1.2.2 and A.8.1.6.

8.6.1.6.3 Test purpose

To verify that the UE meets the minimum requirements. The test is performed in Case 3 fading propagation conditions.

8.6.1.6.4 Method of test

8.6.1.6.4.1 Initial conditions

Test environment: normal; see clauses G.2.1 and G.2.2.

Frequencies to be tested: mid range; see clause G.2.4.

The test parameters are given in table 8.6.1.5.1 and 8.6.1.5.2. In the measurement control information it is indicated to the UE that event-triggered reporting with Event 1A and Event 1F shall be used and “CFN-SFN-Observed Time Difference” shall be reported. The test consists of two successive time periods, each with time duration of T1 and T2 respectively. During time duration T1, the UE shall not have any timing information of invisible cells.

Table 8.6.1.6.1: General test parameters for event triggered reporting in multi-cell pedestrian fading propagation condition

Parameter	Unit	Value	Comment
DCH parameters		DL Reference Measurement Channel 12.2 kbps	As specified in TS 25.101 section A.3.1
Power Control		On	
Active cells		Cell2, Cell3, Cell4	
Hysteresis	dB	0	Applicable for event 1A
Time to Trigger	ms	0	Applicable for event 1A
Filter coefficient		0	Applicable for event 1A and event 1F
Reporting range R_{1a}	dB	8	Applicable for event 1A
W		0	Applicable for event 1A
TriggeringCondition		activeSetAndMonitoredSetCells	Applicable for event 1A
Absolute threshold T_{1f}	dB	-20	Applicable for event 1F
Time to Trigger	ms	0	Applicable for event 1F
TriggeringCondition		activeSet	Applicable for event 1F
Monitored cell list size		32	
T1	s	5	
T2	s	5	

Table 8.6.1.6.2: Cell specific test parameters for event triggered reporting in multi-cell pedestrian fading propagation condition

Parameter	Unit	Cell 1		Cell 2		Cell 3		Cell 4	
		T1	T2	T1	T2	T1	T2	T1	T2
UTRA RF Channel Number		Channel 1		Channel 1		Channel 1		Channel 1	
CPICH_Ec/I _{or}	dB	-10		-10		-10		-10	
PCCPCH_Ec/I _{or}	dB	-12		-12		-12		-12	
SCH_Ec/I _{or}	dB	-9.3		-9.3		-9.3		-9.3	
PICH_Ec/I _{or}	dB	-15		-15		-15		-15	
DPCH_Ec/I _{or}	dB	n.a.		Note 1		Note 1		Note 1	
OCNS_Ec/I _{or}	dB	Note 2		Note 2		Note 2		Note 2	
\hat{I}_{or}/I_{oc}	dB	-∞	1.1	3.6	4.6	3.6	4.6	6.6	-∞
I_{oc}	dBm/3.84 MHz	-70							
Propagation Condition		Case 3 (120km/h)							
CPICH_Ec/I _o	dB	-∞	-18.0	-16.5	-14.5	-16.5	-14.5	-13.5	-∞
$\frac{SCH_E_{c,maxpath}}{I_o}$	dB	-∞	-20.0	-18.5	-16.5	18.5	-16.5	-15.5	-∞
NOTE 1: The DPCH level is controlled by the power control loop. NOTE 2: The power of the OCNS channel that is added shall make the total power equal to I _{or} . NOTE 3: CPICH_Ec/I _o , SCH_Ec_maxpath/I _o , and I _o levels have been calculated from other parameters for information purposes. They are not settable themselves.									

8.6.1.6.4.2 Procedure

- 1) The RF parameters are set up according to T1 in table 8.6.1.6.1.
- 2) The UE is switched on.
- 3) A call is set up with Cell 2 in AWGN conditions, according to the test procedure specified in TS 34.108 [3] sub clause 7.3.2. The scrambling code is set to Cell1.
- 4) SS shall transmit a MEASUREMENT CONTROL message.
- 5) The fading simulator is switched on, configured with the settings in table 8.6.1.6.3. T1 starts.
- 6) During the time period T1, the SS shall send an Active Set Update command with activation time “start of T1” adding cell 3 to the active set. The Active Set Update message shall be sent to the UE so that the whole message is available at the UE at least the RRC procedure delay prior to the beginning of T1.
- 7) During the time period T1, the SS shall send an Active Set Update command with activation time “start of T1” adding cell 4 to the active set. The Active Set Update message shall be sent to the UE so that the whole message is available at the UE at least the RRC procedure delay prior to the beginning of T1.
- 8) After 5 seconds from the beginning of T1, the SS shall switch the power settings from T1 to T2 according to the parameters defined in table 8.6.1.6.3.
- 9) UE shall transmit a MEASUREMENT REPORT message for Cell 1 triggered by event 1A containing the CFN-SFN observe time difference between cell 1 and cell 2. The measurement reporting delay from the beginning of T2 shall be less than 880 ms. If the UE fails to report the event within the required delay, then the counter event1A_failure is increased by one. If the reporting delay for this event is within the required limit, the counter event1A_success is increased by one.
- 10) During the time period T2, SS shall after the Event 1A triggered measurement is reported send an Active Set Update command with activation time “start of T2” removing cell 4 from the active set. The Active Set Update message shall be sent to the UE so that the whole message is available at the UE at least the RRC procedure delay prior to the beginning of T2.

- 11) UE shall transmit a MEASUREMENT REPORT message for Cell 1 triggered by event 1F containing the CFN-SFN observe time difference between cell 1 and cell 2. The measurement reporting delay from the beginning of T2 shall be less than 880 ms. If the UE fails to report the event within the required delay, then the counter event1F_failure is increased by one. If the reporting delay for this event is within the required limit, the counter event1F_success is increased by one.
- 12) After the SS receives the MEASUREMENT REPORT message in step 11) or 5 seconds after the beginning of T2, the SS shall transmit a RRC Connection Release message to make the UE to transit to idle mode.
- 13) SS shall set the new primary code group and primary code on Cell 1. Three different primary code groups and primary codes according to Annex I are used to turn on Cell 1. Previous timing information of cell 1 is invalid in the UE. The RF parameters are set up according to T1 in table 8.6.1.6.3.
- 14) Repeat steps 3-13 according to Annex F.6.2 is achieved. If one counter reaches the pass criterion, this counter is stopped and the remaining counters are continued. For the overall outcome of the test to be considered a pass, the counters for 1A events and for 1F events shall independently indicate a pass result. The test is stopped immediately and the test is considered to be a fail, if any counter reaches an early fail criterion.

Specific Message Contents

All messages indicated above shall use the same content as described in the default message content in clause 9 of 34.108 [3], with the following exceptions:

MEASUREMENT CONTROL message:

Information Element/Group name	Value/Remark
Message Type (10.2.17)	
UE information elements	
-RRC transaction identifier	0
-Integrity check info	
-message authentication code	SS calculates the value of MAC-I for this message and writes to this IE. The first/ leftmost bit of the bit string contains the most significant bit of the MAC-I.
-RRC message sequence number	SS provides the value of this IE, from its internal counter.
Measurement Information elements	
-Measurement Identity	1
-Measurement Command (10.3.7.46)	Modify
-Measurement Reporting Mode (10.3.7.49)	
-Measurement Report Transfer Mode	AM RLC
-Periodical Reporting / Event Trigger Reporting Mode	Event trigger
-Additional measurements list (10.3.7.1)	Not Present
-CHOICE <i>Measurement type</i>	Intra-frequency measurement
-Intra-frequency measurement (10.3.7.36)	
-Intra-frequency measurement objects list (10.3.7.33)	Not Present
-Intra-frequency measurement quantity (10.3.7.38)	
-Filter coefficient (10.3.7.9)	0
-CHOICE mode	FDD
-Measurement quantity	CPICH_Ec/N0
-Intra-frequency reporting quantity (10.3.7.41)	
-Reporting quantities for active set cells (10.3.7.5)	
-Cell synchronisation information reporting indicator	TRUE (Note 1)
-Cell Identity reporting indicator	TRUE
-CHOICE mode	FDD
-CPICH Ec/N0 reporting indicator	TRUE
-CPICH RSCP reporting indicator	TRUE
-Pathloss reporting indicator	FALSE
-Reporting quantities for monitored set cells (10.3.7.5)	
-Cell synchronisation information reporting indicator	TRUE (Note 1)
-Cell Identity reporting indicator	TRUE
-CHOICE mode	FDD
-CPICH Ec/N0 reporting indicator	TRUE
-CPICH RSCP reporting indicator	TRUE
-Pathloss reporting indicator	FALSE
-Reporting quantities for detected set cells (10.3.7.5)	Not Present
-Reporting cell status (10.3.7.61)	Not Present
-Measurement validity (10.3.7.51)	Not Present
-CHOICE report criteria	Intra-frequency measurement reporting criteria
-Intra-frequency measurement reporting criteria (10.3.7.39)	
-Parameters required for each event	2
-Intra-frequency event identity	Event 1A
-Triggering condition 2	Active set cells and monitored set cells
-Reporting Range Constant	8 dB
-Cells forbidden to affect Reporting Range	Not Present
-W	0
-Hysteresis	0 dB
-Threshold used frequency	Not Present
-Reporting deactivation threshold	Not Present
-Replacement activation threshold	Not Present
-Time to trigger	0 ms
-Amount of reporting	Infinity
-Reporting interval	0 ms (Note 2)
-Reporting cell status	
- CHOICE reported cell	Report cell within active set and/or monitored set cells on used frequency
- Maximum number of reported cells	3
-Intra-frequency event identity	Event 1F
-Triggering condition 1	Active set cells
-Reporting Range Constant	Not Present

Information Element/Group name	Value/Remark
-Cells forbidden to affect Reporting Range	Not Present
-W	Not Present
-Hysteresis	Not Present
-Threshold used frequency	-20 dB
-Reporting deactivation threshold	Not Present
-Replacement activation threshold	Not Present
-Time to trigger	0 ms
-Amount of reporting	Not Present
-Reporting interval	0 ms (Note 2)
-Reporting cell status	
- CHOICE reported cell	Report cell within active set and/or monitored set cells on used frequency
- Maximum number of reported cells	3
Physical channel information elements	
-DPCH compressed mode status info (10.3.6.34)	Not Present
Note 1: The SFN-CFN observed time difference is calculated from the OFF and Tm parameters contained in the IE "Cell synchronisation information", TS 25.331, clause 10.3.7.6. According to TS 25.331, 8.6.7.7, this IE is included in MEASUREMENT REPORT if IE "Cell synchronisation information reporting indicator" in IE "Cell reporting quantities" TS 25.331, clause 10.3.7.5 is set to TRUE in MEASUREMENT CONTROL.	
Note 2: Reporting interval = 0 ms means no periodical reporting	

MEASUREMENT REPORT message for Intra frequency test cases

This message is common for all intra frequency test cases is described in Annex I.

8.6.1.6.5 Test requirements

For the test to pass, the total number of successful tests shall be at least 90% of the cases with a confidence level of 95%. For the overall outcome of the test to be considered a pass, the counters for Event 1A and for Event 1F shall independently indicate a pass result.

Table 8.6.1.6.3: Test requirements for Cell specific test parameters for event triggered reporting in multi-cell pedestrian fading propagation condition

Parameter	Unit	Cell 1		Cell 2		Cell 3		Cell 4	
		T1	T2	T1	T2	T1	T2	T1	T2
UTRA RF Channel Number		Channel 1		Channel 1		Channel 1		Channel 1	
CPICH_Ec/lor	dB	-9.3		-9.3		-9.3		-9.3	
PCCPCH_Ec/lor	dB	-11.3		-11.3		-11.3		-11.3	
SCH_Ec/lor	dB	-8.6		-8.6		-8.6		-8.6	
PICH_Ec/lor	dB	-14.3		-14.3		-14.3		-14.3	
DPCH_Ec/lor	dB	n.a.		Note 1		Note 1		Note 1	
OCNS_Ec/lor	dB	Note 2		Note 2		Note 2		Note 2	
\hat{I}_{or} / I_{oc}	dB	-∞	0.80	3.3	4.3	3.3	4.3	6.3	-∞
I_{oc}	dBm/3.84 MHz	-70							
Propagation Condition		Case 3 (120km/h)							
CPICH_Ec/lo	dB	-∞	-17.3	-15.8	-13.8	-15.8	-13.8	-12.8	-∞
$\frac{SCH - \hat{E}_{c,maxpath}}{I_o}$	dB	-∞	-19.3	-17.8	-15.8	-17.8	-15.8	-14.8	-∞
NOTE 1: The DPCH level is controlled by the power control loop. NOTE 2: The power of the OCNS channel that is added shall make the total power equal to I_{or} . NOTE 3: CPICH_Ec/lo, SCH_Ec_maxpath/lo, and I_o levels have been calculated from other parameters for information purposes. They are not settable themselves.									

NOTE: If the above Test Requirement differs from the Minimum Requirement then the Test Tolerance applied for this test is non-zero. The Test Tolerance for this test is defined in clause F.2 and the explanation of how the Minimum Requirement has been relaxed by the Test Tolerance is given in clause F.4.

8.6.2 FDD inter frequency measurements

8.6.2.1 Correct reporting of neighbours in AWGN propagation condition (Release 5 and earlier)

8.6.2.1.1 Definition and applicability

In the event triggered reporting period the measurement reporting delay is defined as the time between any event that will trigger a measurement report until the UE starts to transmit the measurement report over the Uu interface. This requirement assumes that the measurement report is not delayed by other RRC signalling on the DCCH. This measurement reporting delay excludes a delay uncertainty resulted when inserting the measurement report to the TTI of the uplink DCCH. The delay uncertainty is twice the TTI of the uplink DCCH.

The requirements and this test apply to all types of UTRA for the FDD UE for Release 5 and earlier releases.

8.6.2.1.2 Minimum requirements

The UE shall be able to identify a new detectable cell belonging to the monitored set within

$$T_{\text{identify_inter}} = \text{Max} \left\{ 5000, T_{\text{basic_identify_FDD,inter}} \cdot \frac{T_{\text{Measurement_Period_Inter}}}{T_{\text{Inter}}} \cdot N_{\text{Freq}} \right\} \text{ms}$$

A cell shall be considered detectable when CPICH Ec/Io \geq -20 dB, SCH_Ec/Io \geq -17 dB for at least one channel tap and SCH_Ec/Ior is equally divided between primary synchronisation code and secondary synchronisation code. When L3 filtering is used an additional delay can be expected.

When transmission gaps are scheduled for FDD inter frequency measurements the UE physical layer shall be capable of reporting measurements to higher layers with measurement accuracy as specified in sub-clause 9.1.1 and 9.1.2 of 25.133 [2] with measurement period given by

$$T_{\text{measurement_inter}} = \text{Max} \left\{ T_{\text{Measurement_Period_Inter}}, T_{\text{basic_measurement_FDD_inter}} \cdot \frac{T_{\text{Measurement_Period_Inter}}}{T_{\text{Inter}}} \cdot N_{\text{Freq}} \right\} \text{ms}$$

If the UE does not need compressed mode to perform inter-frequency measurements, the measurement period for inter frequency measurements is 480 ms.

The UE shall be capable of performing CPICH measurements for $X_{\text{basic_measurement_FDD_inter}}$ inter-frequency cells per FDD frequency of the monitored set or the virtual active set, and the UE physical layer shall be capable of reporting measurements to higher layers with the measurement period of $T_{\text{Measurement_Inter}}$.

$$X_{\text{basic_measurement_FDDinter}} = 6$$

$T_{\text{Measurement_Period_Inter}} = 480$ ms. The period used for calculating the measurement period $T_{\text{measurement_inter}}$ for inter frequency CPICH measurements.

T_{Inter} : This is the minimum time that is available for inter frequency measurements, during the period $T_{\text{Measurement_Period_inter}}$ with an arbitrarily chosen timing. The minimum time per transmission gap is calculated by using the actual idle length within the transmission gap as given in the table 11 of Annex B in TS 25.212 [31] and by assuming 2*0.5 ms for implementation margin and after that taking only full slots into account in the calculation.

$T_{\text{basic_identify_FDD,inter}} = 800$ ms. This is the time period used in the inter frequency equation where the maximum allowed time for the UE to identify a new FDD cell is defined.

$T_{\text{basic_measurement_FDD_inter}} = 50$ ms. This is the time period used in the equation for defining the measurement period for inter frequency CPICH measurements.

N_{Freq} : Number of FDD frequencies indicated in the inter frequency measurement control information.

The event triggered measurement reporting delay, measured without L3 filtering shall be less than $T_{\text{identify_inter}}$ defined in Clause 8.1.2.3.1 of 25.133 [2] When L3 filtering is used an additional delay can be expected.

If a cell has been detectable at least for the time period $T_{\text{identify_inter}}$ and then enters or leaves the reporting range, the event triggered measurement reporting delay shall be less than $T_{\text{Measurement_Period Inter}}$ provided the timing to that cell has not changed more than ± 32 chips while transmission gap has not been available and the L3 filter has not been used.

The normative reference for these requirements is TS 25.133 [2] clauses 8.1.2.3 and A.8.2.1.

8.6.2.1.3 Test purpose

To verify that the UE meets the minimum requirements.

8.6.2.1.4 Method of test

8.6.2.1.4.1 Initial conditions

Test environment: normal; see clauses G.2.1 and G.2.2.

Frequencies to be tested: mid range; see clause G.2.4.

The initial test parameters are given in table 8.6.2.1.1

Table 8.6.2.1.1: Cell specific initial test parameters for Correct reporting of neighbours in AWGN propagation condition

Parameter	Unit	Cell 1	Cell 2	Cell3
		T0	T0	T0
CPICH_Ec/Ior	dB	-10	-10	-10
PCCPCH_Ec/Ior	dB	-12	-12	-12
SCH_Ec/Ior	dB	-12	-12	-12
PICH_Ec/Ior	dB	-15	-15	-15
DPCH_Ec/Ior	dB	Note 1	N/A	N/A
OCNS_Ec/Ior	dB	Note 2	-0.941	-0.941
\hat{I}_{or}/I_{oc}	dB	0	-Inf	-Inf
\hat{I}_{or} (Note 3)	dBm	-70	-Inf	-Inf
I_{oc}	dBm/3.84 MHz	-70		
CPICH_Ec/Io	dB	-13	-Inf	-Inf
Propagation Condition		AWGN		
Note 1:	The DPCH level is controlled by the power control loop.			
Note 2:	The power of the OCNS channel that is added shall make the total power from the cell to be equal to I_{or} .			
Note 3:	The nominal \hat{I}_{or} values, although not explicitly defined in 25.133 [2] are added here since they are implied and need to be identified so that the test equipment can be configured.			

The test consists of two successive time periods, with a time duration T1 and T2. The test parameters are given in tables 8.6.2.1.2 and 8.6.2.1.3 below. In the measurement control information it is indicated to the UE that event-triggered reporting with Event 1A and 2C shall be used. The CPICH Ec/I0 of the best cell on the unused frequency shall be reported together with Event 2C reporting.

Table 8.6.2.1.2: General test parameters for Correct reporting of neighbours in AWGN propagation condition

Parameter	Unit	Value	Comment
DCH parameters		DL and UL Reference Measurement Channel 12.2 kbps	As specified in C.3.1 and C.2.1
Power Control		On	
Compressed mode		C.5.2 set 1	As specified in C.5.
Active cell		Cell 1	
Threshold non used frequency	dB	-18	Absolute E_c/I_0 threshold for event 2C
Reporting range	dB	4	Applicable for event 1A
Hysteresis	dB	0	
W		1	Applicable for event 1A
W non-used frequency		1	Applicable for event 2C
Reporting deactivation threshold		0	Applicable for event 1A
Time to Trigger	ms	0	
Filter coefficient		0	
Monitored cell list size		24 on channel 1 16 on channel 2	NOTE: See Annex I for cell information. The information is sent before the compressed mode pattern starts.
T1	s	10	
T2	s	5	

Table 8.6.2.1.3: Cell Specific parameters for Correct reporting of neighbours in AWGN propagation condition

Parameter	Unit	Cell 1		Cell 2		Cell 3	
		T1	T2	T1	T2	T1	T2
UTRA RF Channel Number		Channel 1		Channel 1		Channel 2	
CPICH_Ec/I _{or}	dB	-10		-10		-10	
PCCPCH_Ec/I _{or}	dB	-12		-12		-12	
SCH_Ec/I _{or}	dB	-12		-12		-12	
PICH_Ec/I _{or}	dB	-15		-15		-15	
DPCH_Ec/I _{or}	dB	Note 1		N/A		N/A	
OCNS_Ec/I _{or}	dB	Note 2		-0.941		-0.941	
\hat{I}_{or}/I_{oc}	dB	0	5.42	-Infinity	3.92	-1.8	-1.8
\hat{I}_{or} (Note 3)	dBm	-70	-64.58	-Infinity	-66.08	-71.80	-71.80
I_{oc}	dBm/3.84 MHz	-70				-70	
CPICH_Ec/I _o	dB	-13	-13	-Infinity	-14.5	-14	-14
Propagation Condition	AWGN						
Note 1: The DPCH level is controlled by the power control loop. Note 2: The power of the OCNS channel that is added shall make the total power from the cell to be equal to I_{or} . Note 3: The nominal I_{or} values, although not explicitly defined in 25.133 [2] are added here since they are implied and need to be identified so that the test equipment can be configured.							

8.6.2.1.4.2 Procedure

- 1) The parameters are set up according to table 8.6.2.1.2 and table 8.6.2.1.4.
- 2) The UE is switched on.
- 3) A call is set up according to the test procedure specified in TS 34.108 [3] sub clause 7.3.2. The scrambling code is set to Cell2 and Cell3.
- 4) SS shall transmit a MEASUREMENT CONTROL message (inter frequency).
- 5) SS shall transmit a MEASUREMENT CONTROL message (intra frequency).

- 6) SS shall transmit PHYSICAL CHANNEL RECONFIGURATION message.
- 7) UE shall transmit PHYSICAL CHANNEL RECONFIGURATION COMPLETE message.
- 8) 5 seconds after step 7 has completed, the SS shall switch the power settings from T0 to T1 according to the parameters defined in table 8.6.2.1.5.
- 9) UE shall transmit a MEASUREMENT REPORT message (inter frequency) triggered by event 2C. The measurement reporting delay from the beginning of T1 shall be less than 9.08 seconds. If the UE fails to report the event within the required delay, then the counter event2C_failure is increased by one. If the reporting delay for this event is within the required limit, the counter event2C_success is increased by one.
- 10) After 10 seconds from the beginning of T1, the SS shall switch the power settings from T1 to T2 according to the parameters defined in table 8.6.2.1.5.
- 11) UE shall transmit a MEASUREMENT REPORT message (intra frequency) triggered by event 1A. The measurement reporting delay from the beginning of T2 shall be less than 1040 ms. If the UE fails to report the event within the required delay, then the counter event1A_failure is increased by one. If the reporting delay for this event is within the required limit, the counter event1A_success is increased by one.
- 12) After the SS receive the MEASUREMENT REPORT message in step 11) or 5 seconds after the beginning of T2, the SS shall transmit a RRC Connection Release message to make the UE to transit to idle mode.
- 13) SS shall set the new primary code groups and primary codes on Cell2 and Cell3. Three different primary code groups and primary codes according to Annex I are used to turn on Cell2 and Cell3. Previous timing information of Cell 2 and Cell3 are invalid in the UE. The RF parameters are set up according to T0.
- 14) Repeat steps 3-13 used with three different primary code groups and primary codes on Cell2 and Cell3 until the confidence level according to annex F.6.2 is achieved. If one counter reaches the pass criterion, this counter is stopped and the remaining counters are continued. For the overall outcome of the test to be considered a pass, the counters for 2C events and for 1A events shall independently indicate a pass result. The test is stopped immediately and the test is considered to be a fail, if any counter reaches an early fail criterion.

NOTE: The measurement reporting delay is 956.2 ms plus 80 ms delay uncertainty (twice the TTI). This gives a total of 1036.2 ms and rounded off to 1040 ms.

Specific Message Contents

All messages indicated above shall use the same content as described in the default message content in clause 9 of 34.108 [3], with the following exceptions:

PHYSICAL CHANNEL RECONFIGURATION message for Inter frequency measurement:

Information Element	Value/Remark	Version
Message Type		
UE Information Elements		
-RRC transaction identifier	0	
-Integrity check info	SS calculates the value of MAC-I for this message and writes to this IE. The first/leftmost bit of the bit string contains the most significant bit of the MAC-I.	
-message authentication code	SS provides the value of this IE, from its internal counter.	
-RRC message sequence number	Not Present	
-Integrity protection mode info	Not Present	
-Ciphering mode info	Not Present	
-Activation time	Not Present	
-New U-RNTI	Not Present	
-New C-RNTI	Not Present	
-RRC State Indicator	CELL_DCH	
-UTRAN DRX cycle length coefficient	Not Present	
CN Information Elements		
-CN Information info	Not Present	
UTRAN mobility information elements		
-URA identity	Not Present	
RB information elements		
-Downlink counter synchronisation info	Not Present	
PhyCH information elements		
-Frequency info	Not Present	
Uplink radio resources		
-Maximum allowed UL TX power	Not Present	
Downlink radio resources		
-CHOICE mode	FDD	
-Downlink PDSCH information	Not Present	R99 and Rel-4 only
-Downlink information common for all radio links	Not Present	
-Downlink DPCH info common for all RL	FDD	
-CHOICE mode		
-DPCH compressed mode info		
-Transmission gap pattern sequence	1	
-TGPSI	Activate	
-TGPS Status Flag	(Current CFN + (256 – TTI/10msec))mod 256	
-TGCFN		
-Transmission gap pattern sequence configuration parameters		
-TGMP	FDD measurement	
-TGPRC	Infinity	
-TGSN	4	
-TGL1	7	
-TGL2	Not Present	
-TGD	UNDEFINED	
-TGPL1	3	
-TGPL2	Not Present	R99 and Rel-4 only
-RPP	Mode 0	
-ITP	Mode 0	
-CHOICE UL/DL mode	UL and DL	
-Downlink compressed mode method	SF/2	
-Uplink compressed mode method	SF/2	
-Downlink frame type	B	
-DeltaSIR1	3.0	
-DeltaSIRafter1	3.0	
-DeltaSIR2	Not Present	
-DeltaSIRafter2	Not Present	
-N Identify abort	Not Present	
-T Reconfirm abort	Not Present	
-TX Diversity Mode	Not Present	
-SSDT information	Not Present	R99 and Rel-4 only

-Default DPCH Offset Value	Not Present	
-Downlink information per radio link list		
- Downlink information for each radio link		
-Choice mode	FDD	
-Primary CPICH info	100	
-Primary scrambling code	Not Present	R99 and Rel-4 only
-PDSCH with SHO DCH Info		
-PDSCH code mapping	Not Present	R99 and Rel-4 only
-Downlink DPCH info for each RL		
-CHOICE mode	FDD	
-Primary CPICH usage for channel estimation	Primary CPICH may be used	
-DPCH frame offset	Set to value Default DPCH Offset Value (as currently stored in SS) mod 38400	
-Secondary CPICH info	Not Present	
-DL channelisation code		
-Secondary scrambling code	Not Present	
-Spreading factor	128	
-Code number	96	
-Scrambling code change	No code change	
-TPC combination index	0	
-SSDT Cell Identity	Not Present	R99 and Rel-4 only
-Closed loop timing adjustment mode	Not Present	
-SCCPCH Information for FACH	Not Present	

MEASUREMENT CONTROL message (inter frequency):

Information Element/Group name	Value/Remark
Message Type (10.2.17)	
UE information elements	
-RRC transaction identifier	0
-Integrity check info	
-message authentication code	SS calculates the value of MAC-I for this message and writes to this IE. The first/leftmost bit of the bit string contains the most significant bit of the MAC-I.
-RRC message sequence number	SS provides the value of this IE, from its internal counter.
Measurement Information elements	
-Measurement Identity	2
-Measurement Command (10.3.7.46)	Setup
-Measurement Reporting Mode (10.3.7.49)	
-Measurement Report Transfer Mode	AM RLC
-Periodical Reporting / Event Trigger Reporting Mode	Event trigger
-Additional measurements list (10.3.7.1)	Not Present
-CHOICE <i>Measurement type</i>	Inter-frequency measurement
-Inter-frequency measurement (10.3.7.16)	
-Inter-frequency measurement objects list (10.3.7.13)	
- CHOICE Inter-frequency cell removal	Not Present
- New Inter frequency cells	
- Inter frequency cell id	4
- Frequency info	
- CHOICE mode	FDD
- UARFCN uplink(Nu)	Not Present
- UARFCN downlink(Nd)	Same frequency as "Channel2" in Table 8.6.2.1.5
- Cell info	
- Cell individual offset	Not Present
- Reference time difference to cell	Not Present
- Read SFN indicator	FALSE
- CHOICE mode	FDD
- Primary CPICH info	
- Primary scrambling code	Set to Primary scrambling code of Cell3
- Primary CPICH Tx Power	Set to Primary CPICH Tx Power of Cell3 described in Table 8.6.2.1.5
- Tx Diversity Indicator	FALSE
- Cell for measurement	Not Present
-Inter-frequency measurement quantity (10.3.7.18)	
-CHOICE reporting criteria	Inter-frequency reporting criteria
-Filter coefficient (10.3.7.9)	0
-CHOICE mode	FDD
-Measurement quantity for frequency quality estimate	CPICH_Ec/N0
-Inter-frequency reporting quantity (10.3.7.21)	
-UTRA Carrier RSSI	FALSE
-Frequency quality estimate	FALSE
-Non frequency related cell reporting quantities (10.3.7.5)	
-Cell synchronisation information reporting indicator	TRUE (Note 1)
-Cell Identity reporting indicator	TRUE
-CHOICE mode	FDD
-CPICH Ec/N0 reporting indicator	TRUE
-CPICH RSCP reporting indicator	TRUE
-Pathloss reporting indicator	FALSE
-Reporting cell status (10.3.7.61)	Not Present
-Measurement validity (10.3.7.51)	Not Present
- Inter-frequency set update (10.3.7.22)	
-UE autonomous update mode	On with no reporting
-CHOICE report criteria	Inter-frequency measurement reporting criteria
-Inter-frequency measurement reporting criteria (10.3.7.19)	
-Parameters required for each event	1
-Inter-frequency event identity	Event 2C
-Threshold used frequency	Not present
-W used frequency	Not present

Information Element/Group name	Value/Remark
-Hysteresis -Time to trigger -Reporting cell status -CHOICE reported cell -Maximum number of reported cells -Parameters required for each non-used frequency -Threshold non used frequency -W non-used frequency	0 dB 0 ms Report cells within monitored and/or virtual active set on non-used frequency 3 -18 dB 1
Physical channel information elements -DPCH compressed mode status info (10.3.6.34)	Not Present
NOTE 1: The SFN-CFN observed time difference is calculated from the OFF and Tm parameters contained in the IE "Cell synchronisation information", TS 25.331, clause 10.3.7.6. According to TS 25.331, 8.6.7.7, this IE is included in MEASUREMENT REPORT if IE "Cell synchronisation information reporting indicator" in IE "Cell reporting quantities" TS 25.331, clause 10.3.7.5 is set to TRUE in MEASUREMENT CONTROL.	

MEASUREMENT CONTROL message (intra frequency):

Information Element/Group name	Value/Remark
Message Type (10.2.17)	
UE information elements	
-RRC transaction identifier	0
-Integrity check info	
-message authentication code	SS calculates the value of MAC-I for this message and writes to this IE. The first/ leftmost bit of the bit string contains the most significant bit of the MAC-I.
-RRC message sequence number	SS provides the value of this IE, from its internal counter.
Measurement Information elements	
-Measurement Identity	1
-Measurement Command (10.3.7.46)	Modify
-Measurement Reporting Mode (10.3.7.49)	
-Measurement Report Transfer Mode	AM RLC
-Periodical Reporting / Event Trigger Reporting Mode	Event trigger
-Additional measurements list (10.3.7.1)	Not Present
-CHOICE <i>Measurement type</i>	Intra-frequency measurement
-Intra-frequency measurement (10.3.7.36)	
-Intra-frequency measurement objects list (10.3.7.33)	Not Present
-Intra-frequency measurement quantity (10.3.7.38)	
-Filter coefficient (10.3.7.9)	0
-CHOICE mode	FDD
-Measurement quantity	CPICH_Ec/N0
-Intra-frequency reporting quantity (10.3.7.41)	
-Reporting quantities for active set cells (10.3.7.5)	
-Cell synchronisation information reporting indicator	TRUE (Note 1)
-Cell Identity reporting indicator	TRUE
-CHOICE mode	FDD
-CPICH Ec/N0 reporting indicator	TRUE
-CPICH RSCP reporting indicator	TRUE
-Pathloss reporting indicator	FALSE
-Reporting quantities for monitored set cells (10.3.7.5)	
-Cell synchronisation information reporting indicator	TRUE (Note 1)
-Cell Identity reporting indicator	TRUE
-CHOICE mode	FDD
-CPICH Ec/N0 reporting indicator	TRUE
-CPICH RSCP reporting indicator	TRUE
-Pathloss reporting indicator	FALSE
-Reporting quantities for detected set cells (10.3.7.5)	Not Present
-Reporting cell status (10.3.7.61)	Not Present
-Measurement validity (10.3.7.51)	Not Present
-CHOICE report criteria	Intra-frequency measurement reporting criteria
-Intra-frequency measurement reporting criteria (10.3.7.39)	
-Parameters required for each event	1
-Intra-frequency event identity	Event 1A
-Triggering condition 2	Monitored set cells
-Reporting Range Constant	4 dB
-Cells forbidden to affect Reporting Range	Not Present
-CHOICE mode	FDD
-Primary CPICH info (10.3.6.60)	
-W	1.0
-Hysteresis	0 dB
-Threshold used frequency	Not Present
-Reporting deactivation threshold	0
-Replacement activation threshold	Not Present
-Time to trigger	0 ms
-Amount of reporting	Infinity
-Reporting interval	0 ms (Note 2)
-Reporting cell status	Not Present
Physical channel information elements	
-DPCH compressed mode status info (10.3.6.34)	Not Present

Information Element/Group name	Value/Remark
Note 1:	The SFN-CFN observed time difference is calculated from the OFF and Tm parameters contained in the IE "Cell synchronisation information", TS 25.331, clause 10.3.7.6. According to TS 25.331, 8.6.7.7, this IE is included in MEASUREMENT REPORT if IE "Cell synchronisation information reporting indicator" in IE "Cell reporting quantities" TS 25.331, clause 10.3.7.5 is set to TRUE in MEASUREMENT CONTROL.
Note 2:	Reporting interval = 0 ms means no periodical reporting

MEASUREMENT REPORT message for Inter frequency test cases

MEASUREMENT REPORT message for Intra frequency test cases

These messages are common for all inter and intra frequency test cases and are described in Annex I.

8.6.2.1.5 Test requirements

For the test to pass, the total number of successful tests shall be at least 90% of the cases with a confidence level of 95%. For the overall outcome of the test to be considered a pass, the counters for 2C events and for 1A events shall independently indicate a pass result.

Table 8.6.2.1.4: Test requirements for initial test parameters for Correct reporting of neighbours in AWGN propagation condition

Parameter	Unit	Cell 1	Cell 2	Cell3
		T0	T0	T0
CPICH_Ec/Ior	dB	-9.2	-9.2	-9.2
PCCPCH_Ec/Ior	dB	-11.2	-11.2	-11.2
SCH_Ec/Ior	dB	-11.2	-11.2	-11.2
PICH_Ec/Ior	dB	-14.2	-14.2	-14.2
DPCH_Ec/Ior	dB	Note 1	N/A	N/A
OCNS_Ec/Ior	dB	Note 2	-1.16	-1.16
\hat{I}_{or}/I_{oc} (Note 3)	dB	0	-Inf	-Inf
\hat{I}_{or}	dBm	-70	-Inf	-Inf
I_{oc}	dBm/3.84 MHz	-70		
CPICH_Ec/Io (Note 3)	dB	-12.21	-Inf	-Inf
Propagation Condition		AWGN		
Note 1:	The DPCH level is controlled by the power control loop.			
Note 2:	The power of the OCNS channel that is added shall make the total power from the cell to be equal to I_{or} .			
Note 3:	These parameters are not directly settable, but are derived by calculation from the settable parameters.			

Table 8.6.2.1.5: Test requirements for Correct reporting of neighbours in AWGN propagation condition

Parameter	Unit	Cell 1		Cell 2		Cell 3	
		T1	T2	T1	T2	T1	T2
UTRA RF Channel Number		Channel 1		Channel 1		Channel 2	
CPICH_Ec/Ior	dB	-9.2		-9.2		-9.2	
PCCPCH_Ec/Ior	dB	-11.2		-11.2		-11.2	
SCH_Ec/Ior	dB	-11.2		-11.2		-11.2	
PICH_Ec/Ior	dB	-14.2		-14.2		-14.2	
DPCH_Ec/Ior	dB	Note 1		N/A		N/A	
OCNS_Ec/Ior	dB	Note 2		-1.16		-1.16	
\hat{I}_{or}/I_{oc} (Note 3)	dB	0	5.42	-Infinity	3.9	-1.8	-1.8
\hat{I}_{or}	dBm	-70	-64.6	-Infinity	-66.10	-71.8	-71.8
I_{oc}	dBm/3.84 MHz	-70					
CPICH_Ec/Io (Note 3)	dB	-12.21	-12.20	-Infinity	-13.70	-13.20	-13.20
Propagation Condition	AWGN						
Note 1:	The DPCH level is controlled by the power control loop.						
Note 2:	The power of the OCNS channel that is added shall make the total power from the cell to be equal to I_{or} .						
Note 3:	These parameters are not directly settable, but are derived by calculation from the settable parameters.						

NOTE: If the above Test Requirement differs from the Minimum Requirement then the Test Tolerance applied for this test is non-zero. The Test Tolerance for this test is defined in clause F.2 and the explanation of how the Minimum Requirement has been relaxed by the Test Tolerance is given in clause F.4.

8.6.2.1A Correct reporting of neighbours in AWGN propagation condition (Release 6 and later)

8.6.2.1A.1 Definition and applicability

In the event triggered reporting period the measurement reporting delay is defined as the time between any event that will trigger a measurement report until the UE starts to transmit the measurement report over the Uu interface. This requirement assumes that the measurement report is not delayed by other RRC signalling on the DCCH. This measurement reporting delay excludes a delay uncertainty resulted when inserting the measurement report to the TTI of the uplink DCCH. The delay uncertainty is twice the TTI of the uplink DCCH.

The requirements and this test apply to Release 6 and later release for all types of UTRA for the FDD UE.

8.6.2.1A.2 Minimum requirements

The UE shall be able to identify a new detectable cell belonging to the monitored set within

$$T_{\text{identify, inter}} = T_{\text{basic identify FDD,inter}} \cdot \frac{T_{\text{Measurement Period, Inter}}}{T_{\text{Inter}}} \cdot N_{\text{Freq}} \quad \text{ms}$$

A cell shall be considered detectable when CPICH Ec/Io \geq -20 dB, SCH_Ec/Io \geq -17 dB for at least one channel tap and SCH_Ec/Ior is equally divided between primary synchronisation code and secondary synchronisation code. When L3 filtering is used an additional delay can be expected.

When transmission gaps are scheduled for FDD inter frequency measurements the UE physical layer shall be capable of reporting measurements to higher layers with measurement accuracy as specified in sub-clause 9.1.1 and 9.1.2 of 25.133 [2] with measurement period given by

$$T_{\text{measurement_inter}} = \text{Max} \left\{ T_{\text{Measurement_Period_Inter}}, T_{\text{basic_measurement_FDD_inter}} \cdot \frac{T_{\text{Measurement_Period_Inter}}}{T_{\text{Inter}}} \cdot N_{\text{Freq}} \right\} \text{ms}$$

If the UE does not need compressed mode to perform inter-frequency measurements, the measurement period for inter frequency measurements is 480 ms.

The UE shall be capable of performing CPICH measurements for $X_{\text{basic_measurement_FDD_inter}}$ inter-frequency cells per FDD frequency of the monitored set or the virtual active set, and the UE physical layer shall be capable of reporting measurements to higher layers with the measurement period of $T_{\text{Measurement_Inter}}$.

$$X_{\text{basic_measurement_FDD_inter}} = 6$$

$T_{\text{Measurement_Period_Inter}} = 480$ ms. The period used for calculating the measurement period $T_{\text{measurement_inter}}$ for inter frequency CPICH measurements.

T_{Inter} : This is the minimum time that is available for inter frequency measurements, during the period $T_{\text{Measurement_Period_inter}}$ with an arbitrarily chosen timing. The minimum time per transmission gap is calculated by using the actual idle length within the transmission gap as given in the table 11 of Annex B in TS 25.212 [31] and by assuming $2 \cdot 0.5$ ms for implementation margin and after that taking only full slots into account in the calculation.

$T_{\text{basic_identify_FDD_inter}} = 300$ ms. This is the time period used in the inter frequency equation where the maximum allowed time for the UE to identify a new FDD cell is defined.

$T_{\text{basic_measurement_FDD_inter}} = 50$ ms. This is the time period used in the equation for defining the measurement period for inter frequency CPICH measurements.

N_{Freq} : Number of FDD frequencies indicated in the inter frequency measurement control information.

The event triggered measurement reporting delay, measured without L3 filtering shall be less than $T_{\text{identify_inter}}$ defined in Clause 8.1.2.3.1 of 25.133 [2] When L3 filtering is used an additional delay can be expected.

If a cell has been detectable at least for the time period $T_{\text{identify_inter}}$ and then enters or leaves the reporting range, the event triggered measurement reporting delay shall be less than $T_{\text{Measurement_Period_Inter}}$ provided the timing to that cell has not changed more than ± 32 chips while transmission gap has not been available and the L3 filter has not been used.

The normative reference for these requirements is TS 25.133 [2] clauses 8.1.2.3 and A.8.2.1.

8.6.2.1A.3 Test purpose

To verify that the UE meets the minimum requirements.

8.6.2.1A.4 Method of test

8.6.2.1A.4.1 Initial conditions

Test environment: normal; see clauses G.2.1 and G.2.2.

Frequencies to be tested: mid range; see clause G.2.4.

The initial test parameters are given in table 8.6.2.1A.1

Table 8.6.2.1A.1: Cell specific initial test parameters for Correct reporting of neighbours in AWGN propagation condition

Parameter	Unit	Cell 1	Cell 2	Cell3
		T0	T0	T0
CPICH_Ec/I _{or}	dB	-10	-10	-10
PCCPCH_Ec/I _{or}	dB	-12	-12	-12
SCH_Ec/I _{or}	dB	-12	-12	-12
PICH_Ec/I _{or}	dB	-15	-15	-15
DPCH_Ec/I _{or}	dB	Note 1	N/A	N/A
OCNS_Ec/I _{or}	dB	Note 2	-0.941	-0.941
\hat{I}_{or}/I_{oc}	dB	0	-Inf	-Inf
\hat{I}_{or} (Note 3)	dBm	-70	-Inf	-Inf
I_{oc}	dBm/3.84 MHz		-70	
CPICH_Ec/I _o	dB	-13	-Inf	-Inf
Propagation Condition		AWGN		
Note 1:	The DPCH level is controlled by the power control loop.			
Note 2:	The power of the OCNS channel that is added shall make the total power from the cell to be equal to I_{or} .			
Note 3:	The nominal \hat{I}_{or} values, although not explicitly defined in 25.133 [2] are added here since they are implied and need to be identified so that the test equipment can be configured.			

The test consists of two successive time periods, with a time duration T1 and T2. The test parameters are given in tables 8.6.2.1A.2 and 8.6.2.1A.3 below. In the measurement control information it is indicated to the UE that event-triggered reporting with Event 1A and 2C shall be used. The CPICH Ec/I_o of the best cell on the unused frequency shall be reported together with Event 2C reporting.

Table 8.6.2.1A.2: General test parameters for Correct reporting of neighbours in AWGN propagation condition

Parameter	Unit	Value	Comment
DCH parameters		DL and UL Reference Measurement Channel 12.2 kbps	As specified in C.3.1 and C.2.1
Power Control		On	
Compressed mode		C.5.2 set 1	As specified in C.5.
Active cell		Cell 1	
Threshold non used frequency	dB	-18	Absolute Ec/I _o threshold for event 2C
Reporting range	dB	4	Applicable for event 1A
Hysteresis	dB	0	
W		1	Applicable for event 1A
W non-used frequency		1	Applicable for event 2C
Reporting deactivation threshold		0	Applicable for event 1A
Time to Trigger	ms	0	
Filter coefficient		0	
Monitored cell list size		24 on channel 1 16 on channel 2	NOTE: See Annex I for cell information. The information is sent before the compressed mode pattern starts.
T1	s	5	
T2	s	5	

Table 8.6.2.1A.3: Cell Specific parameters for Correct reporting of neighbours in AWGN propagation condition

Parameter	Unit	Cell 1		Cell 2		Cell 3	
		T1	T2	T1	T2	T1	T2
UTRA RF Channel Number		Channel 1		Channel 1		Channel 2	
CPICH_Ec/lor	dB	-10		-10		-10	
PCCPCH_Ec/lor	dB	-12		-12		-12	
SCH_Ec/lor	dB	-12		-12		-12	
PICH_Ec/lor	dB	-15		-15		-15	
DPCH_Ec/lor	dB	Note 1		N/A		N/A	
OCNS_Ec/lor	dB	Note 2		-0.941		-0.941	
\hat{I}_{or}/I_{oc}	dB	0	5.42	-Infinity	3.92	-1.8	-1.8
\hat{I}_{or} (Note 3)	dBm	-70	-64.58	-Infinity	-66.08	-71.80	-71.80
I_{oc}	dBm/3.84 MHz	-70				-70	
CPICH_Ec/lo	dB	-13	-13	-Infinity	-14.5	-14	-14
Propagation Condition	AWGN						
<p>Note 1: The DPCH level is controlled by the power control loop.</p> <p>Note 2: The power of the OCNS channel that is added shall make the total power from the cell to be equal to I_{or}.</p> <p>Note 3: The nominal I_{or} values, although not explicitly defined in 25.133 [2] are added here since they are implied and need to be identified so that the test equipment can be configured.</p>							

8.6.2.1A.4.2 Procedure

- 1) The parameters are set up according to table 8.6.2.1A.2 and table 8.6.2.1A.4.
- 2) The UE is switched on.
- 3) A call is set up according to the test procedure specified in TS 34.108 [3] sub clause 7.3.2. The scrambling code is set to Cell2 and Cell3.
- 4) SS shall transmit a MEASUREMENT CONTROL message (inter frequency).
- 5) SS shall transmit a MEASUREMENT CONTROL message (intra frequency).
- 6) SS shall transmit PHYSICAL CHANNEL RECONFIGURATION message.
- 7) UE shall transmit PHYSICAL CHANNEL RECONFIGURATION COMPLETE message.
- 8) 5 seconds after step7 has completed, the SS shall switch the power settings from T0 to T1 according to the parameters defined in table 8.6.2.1A.5.
- 9) UE shall transmit a MEASUREMENT REPORT message (inter frequency) triggered by event 2C. The measurement reporting delay from the beginning of T1 shall be less than [3.48] seconds. If the UE fails to report the event within the required delay, then the counter event2C_failure is increased by one. If the reporting delay for this event is within the required limit, the counter event2C_success is increased by one.
- 10) After 5 seconds from the beginning of T1, the SS shall switch the power settings from T1 to T2 according to the parameters defined in table 8.6.2.1A.5.
- 11) UE shall transmit a MEASUREMENT REPORT message (intra frequency) triggered by event 1A. The measurement reporting delay from the beginning of T2 shall be less than 1040 ms. If the UE fails to report the event within the required delay, then the counter event1A_failure is increased by one. If the reporting delay for this event is within the required limit, the counter event1A_success is increased by one.
- 12) After the SS receive the MEASUREMENT REPORT message in step 11) or 5 seconds after the beginning of T2, the SS shall transmits a RRC Connection Release message to make the UE to transit to idle mode.
- 13) SS shall sets the new primary code groups and primary codes on Cell2 and Cell3. Three different primary code groups and primary codes according to Annex I are used to turn on Cell2 and Cell3. Previous timing information of Cell 2 and Cell3 are invalid in the UE. The RF parameters are set up according to T0.

14) Repeat steps 3-13 used with three different primary code groups and primary codes on Cell2 and Cell3 until the confidence level according to annex F.6.2 is achieved. If one counter reaches the pass criterion, this counter is stopped and the remaining counters are continued. For the overall outcome of the test to be considered a pass, the counters for 2C events and for 1A events shall independently indicate a pass result. The test is stopped immediately and the test is considered to be a fail, if any counter reaches an early fail criterion.

NOTE: The measurement reporting delay is 956.2 ms plus 80 ms delay uncertainty (twice the TTI). This gives a total of 1036.2 ms and rounded off to 1040 ms.

Specific Message Contents

All messages indicated above shall use the same content as described in the default message content in clause 9 of 34.108 [3], with the following exceptions:

PHYSICAL CHANNEL RECONFIGURATION message for Inter frequency measurement:

Information Element	Value/Remark	Version
Message Type		
UE Information Elements		
-RRC transaction identifier	0	
-Integrity check info		
-message authentication code	SS calculates the value of MAC-I for this message and writes to this IE. The first/leftmost bit of the bit string contains the most significant bit of the MAC-I.	
-RRC message sequence number	SS provides the value of this IE, from its internal counter.	
-Integrity protection mode info	Not Present	
-Ciphering mode info	Not Present	
-Activation time	Not Present	
-New U-RNTI	Not Present	
-New C-RNTI	Not Present	
-RRC State Indicator	CELL_DCH	
-UTRAN DRX cycle length coefficient	Not Present	
CN Information Elements		
-CN Information info	Not Present	
UTRAN mobility information elements		
-URA identity	Not Present	
RB information elements		
-Downlink counter synchronisation info	Not Present	
PhyCH information elements		
-Frequency info	Not Present	
Uplink radio resources		
-Maximum allowed UL TX power	Not Present	
Downlink radio resources		
-CHOICE mode	FDD	R99 and Rel-4 only
-Downlink PDSCH information	Not Present	
-Downlink information common for all radio links		
-Downlink DPCH info common for all RL	Not Present	
-CHOICE mode	FDD	
-DPCH compressed mode info		
-Transmission gap pattern sequence		
-TGPSI	1	
-TGPS Status Flag	Activate	
-TGCFN	(Current CFN + (256 – TTI/10msec))mod 256	
-Transmission gap pattern sequence configuration parameters		
-TGMP	FDD measurement	
-TGPRC	Infinity	
-TGSN	4	
-TGL1	7	
-TGL2	Not Present	
-TGD	UNDEFINED	
-TGPL1	3	
-TGPL2	Not Present	R99 and Rel-4 only
-RPP	Mode 0	
-ITP	Mode 0	
-CHOICE UL/DL mode	UL and DL	
-Downlink compressed mode method	SF/2	
-Uplink compressed mode method	SF/2	
-Downlink frame type	B	
-DeltaSIR1	3.0	
-DeltaSIRafter1	3.0	
-DeltaSIR2	Not Present	
-DeltaSIRafter2	Not Present	
-N Identify abort	Not Present	
-T Reconfirm abort	Not Present	
-TX Diversity Mode	Not Present	
-SSDT information	Not Present	R99 and Rel-4 only

-Default DPCH Offset Value	Not Present	
-Downlink information per radio link list		
- Downlink information for each radio link		
-Choice mode	FDD	
-Primary CPICH info	100	
-Primary scrambling code	Not Present	R99 and Rel-4 only
-PDSCH with SHO DCH Info		
-PDSCH code mapping	Not Present	R99 and Rel-4 only
-Downlink DPCH info for each RL		
-CHOICE mode	FDD	
-Primary CPICH usage for channel estimation	Primary CPICH may be used	
-DPCH frame offset	Set to value Default DPCH Offset Value (as currently stored in SS) mod 38400	
-Secondary CPICH info	Not Present	
-DL channelisation code		
-Secondary scrambling code	Not Present	
-Spreading factor	128	
-Code number	96	
-Scrambling code change	No code change	
-TPC combination index	0	
-SSDT Cell Identity	Not Present	R99 and Rel-4 only
-Closed loop timing adjustment mode	Not Present	
-SCCPCH Information for FACH	Not Present	

MEASUREMENT CONTROL message (inter frequency):

Information Element/Group name	Value/Remark
Message Type (10.2.17)	
UE information elements	
-RRC transaction identifier	0
-Integrity check info	
-message authentication code	SS calculates the value of MAC-I for this message and writes to this IE. The first/leftmost bit of the bit string contains the most significant bit of the MAC-I.
-RRC message sequence number	SS provides the value of this IE, from its internal counter.
Measurement Information elements	
-Measurement Identity	2
-Measurement Command (10.3.7.46)	Setup
-Measurement Reporting Mode (10.3.7.49)	
-Measurement Report Transfer Mode	AM RLC
-Periodical Reporting / Event Trigger Reporting Mode	Event trigger
-Additional measurements list (10.3.7.1)	Not Present
-CHOICE <i>Measurement type</i>	Inter-frequency measurement
-Inter-frequency measurement (10.3.7.16)	
-Inter-frequency measurement objects list (10.3.7.13)	
- CHOICE Inter-frequency cell removal	Not Present
- New Inter frequency cells	
- Inter frequency cell id	4
- Frequency info	
- CHOICE mode	FDD
- UARFCN uplink(Nu)	Not Present
- UARFCN downlink(Nd)	Same frequency as "Channel2" in Table 8.6.2.1.5
- Cell info	
- Cell individual offset	Not Present
- Reference time difference to cell	Not Present
- Read SFN indicator	FALSE
- CHOICE mode	FDD
- Primary CPICH info	
- Primary scrambling code	Set to Primary scrambling code of Cell3
- Primary CPICH Tx Power	Set to Primary CPICH Tx Power of Cell3 described in Table 8.6.2.1.5
- Tx Diversity Indicator	FALSE
- Cell for measurement	Not Present
-Inter-frequency measurement quantity (10.3.7.18)	
-CHOICE reporting criteria	Inter-frequency reporting criteria
-Filter coefficient (10.3.7.9)	0
-CHOICE mode	FDD
-Measurement quantity for frequency quality estimate	CPICH_Ec/N0
-Inter-frequency reporting quantity (10.3.7.21)	
-UTRA Carrier RSSI	FALSE
-Frequency quality estimate	FALSE
-Non frequency related cell reporting quantities (10.3.7.5)	
-Cell synchronisation information reporting indicator	TRUE (Note 1)
-Cell Identity reporting indicator	TRUE
-CHOICE mode	FDD
-CPICH Ec/N0 reporting indicator	TRUE
-CPICH RSCP reporting indicator	TRUE
-Pathloss reporting indicator	FALSE
-Reporting cell status (10.3.7.61)	Not Present
-Measurement validity (10.3.7.51)	Not Present
- Inter-frequency set update (10.3.7.22)	
-UE autonomous update mode	On with no reporting
-CHOICE report criteria	Inter-frequency measurement reporting criteria
-Inter-frequency measurement reporting criteria (10.3.7.19)	
-Parameters required for each event	1
-Inter-frequency event identity	Event 2C
-Threshold used frequency	Not present
-W used frequency	Not present

Information Element/Group name	Value/Remark
-Hysteresis -Time to trigger -Reporting cell status -CHOICE reported cell -Maximum number of reported cells -Parameters required for each non-used frequency -Threshold non used frequency -W non-used frequency	0 dB 0 ms Report cells within monitored and/or virtual active set on non-used frequency 3 -18 dB 1
Physical channel information elements -DPCH compressed mode status info (10.3.6.34)	Not Present
NOTE 1: The SFN-CFN observed time difference is calculated from the OFF and Tm parameters contained in the IE "Cell synchronisation information", TS 25.331, clause 10.3.7.6. According to TS 25.331, 8.6.7.7, this IE is included in MEASUREMENT REPORT if IE "Cell synchronisation information reporting indicator" in IE "Cell reporting quantities" TS 25.331, clause 10.3.7.5 is set to TRUE in MEASUREMENT CONTROL.	

MEASUREMENT CONTROL message (intra frequency):

Information Element/Group name	Value/Remark
Message Type (10.2.17)	
UE information elements	
-RRC transaction identifier	0
-Integrity check info	
-message authentication code	SS calculates the value of MAC-I for this message and writes to this IE. The first/ leftmost bit of the bit string contains the most significant bit of the MAC-I.
-RRC message sequence number	SS provides the value of this IE, from its internal counter.
Measurement Information elements	
-Measurement Identity	1
-Measurement Command (10.3.7.46)	Modify
-Measurement Reporting Mode (10.3.7.49)	
-Measurement Report Transfer Mode	AM RLC
-Periodical Reporting / Event Trigger Reporting Mode	Event trigger
-Additional measurements list (10.3.7.1)	Not Present
-CHOICE <i>Measurement type</i>	Intra-frequency measurement
-Intra-frequency measurement (10.3.7.36)	
-Intra-frequency measurement objects list (10.3.7.33)	Not Present
-Intra-frequency measurement quantity (10.3.7.38)	
-Filter coefficient (10.3.7.9)	0
-CHOICE mode	FDD
-Measurement quantity	CPICH_Ec/N0
-Intra-frequency reporting quantity (10.3.7.41)	
-Reporting quantities for active set cells (10.3.7.5)	
-Cell synchronisation information reporting indicator	TRUE (Note 1)
-Cell Identity reporting indicator	TRUE
-CHOICE mode	FDD
-CPICH Ec/N0 reporting indicator	TRUE
-CPICH RSCP reporting indicator	TRUE
-Pathloss reporting indicator	FALSE
-Reporting quantities for monitored set cells (10.3.7.5)	
-Cell synchronisation information reporting indicator	TRUE (Note 1)
-Cell Identity reporting indicator	TRUE
-CHOICE mode	FDD
-CPICH Ec/N0 reporting indicator	TRUE
-CPICH RSCP reporting indicator	TRUE
-Pathloss reporting indicator	FALSE
-Reporting quantities for detected set cells (10.3.7.5)	Not Present
-Reporting cell status (10.3.7.61)	Not Present
-Measurement validity (10.3.7.51)	Not Present
-CHOICE report criteria	Intra-frequency measurement reporting criteria
-Intra-frequency measurement reporting criteria (10.3.7.39)	
-Parameters required for each event	1
-Intra-frequency event identity	Event 1A
-Triggering condition 2	Monitored set cells
-Reporting Range Constant	4 dB
-Cells forbidden to affect Reporting Range	Not Present
-CHOICE mode	FDD
-Primary CPICH info (10.3.6.60)	
-W	1.0
-Hysteresis	0 dB
-Threshold used frequency	Not Present
-Reporting deactivation threshold	0
-Replacement activation threshold	Not Present
-Time to trigger	0 ms
-Amount of reporting	Infinity
-Reporting interval	0 ms (Note 2)
-Reporting cell status	Not Present
Physical channel information elements	
-DPCH compressed mode status info (10.3.6.34)	Not Present

Information Element/Group name	Value/Remark
Note 1:	The SFN-CFN observed time difference is calculated from the OFF and Tm parameters contained in the IE "Cell synchronisation information", TS 25.331, clause 10.3.7.6. According to TS 25.331, 8.6.7.7, this IE is included in MEASUREMENT REPORT if IE "Cell synchronisation information reporting indicator" in IE "Cell reporting quantities" TS 25.331, clause 10.3.7.5 is set to TRUE in MEASUREMENT CONTROL.
Note 2:	Reporting interval = 0 ms means no periodical reporting

MEASUREMENT REPORT message for Inter frequency test cases

MEASUREMENT REPORT message for Intra frequency test cases

These messages are common for all inter and intra frequency test cases and are described in Annex I.

8.6.2.1A.5 Test requirements

For the test to pass, the total number of successful tests shall be at least 90% of the cases with a confidence level of 95%. For the overall outcome of the test to be considered a pass, the counters for 2C events and for 1A events shall independently indicate a pass result.

Table 8.6.2.1A.4: Test requirements for initial test parameters for Correct reporting of neighbours in AWGN propagation condition

Parameter	Unit	Cell 1	Cell 2	Cell3
		T0	T0	T0
CPICH_Ec/Ior	dB	-9.2	-9.2	-9.2
PCCPCH_Ec/Ior	dB	-11.2	-11.2	-11.2
SCH_Ec/Ior	dB	-11.2	-11.2	-11.2
PICH_Ec/Ior	dB	-14.2	-14.2	-14.2
DPCH_Ec/Ior	dB	Note 1	N/A	N/A
OCNS_Ec/Ior	dB	Note 2	-1.16	-1.16
\hat{I}_{or}/I_{oc} (Note 3)	dB	0	-Inf	-Inf
\hat{I}_{or}	dBm	-70	-Inf	-Inf
I_{oc}	dBm/3.84 MHz	-70		
CPICH_Ec/Io (Note 3)	dB	-12.21	-Inf	-Inf
Propagation Condition		AWGN		
Note 1:	The DPCH level is controlled by the power control loop.			
Note 2:	The power of the OCNS channel that is added shall make the total power from the cell to be equal to I_{or} .			
Note 3:	These parameters are not directly settable, but are derived by calculation from the settable parameters.			

Table 8.6.2.1A.5: Test requirements for Correct reporting of neighbours in AWGN propagation condition

Parameter	Unit	Cell 1		Cell 2		Cell 3	
		T1	T2	T1	T2	T1	T2
UTRA RF Channel Number		Channel 1		Channel 1		Channel 2	
CPICH_Ec/I _{or}	dB	-9.2		-9.2		-9.2	
PCCPCH_Ec/I _{or}	dB	-11.2		-11.2		-11.2	
SCH_Ec/I _{or}	dB	-11.2		-11.2		-11.2	
PICH_Ec/I _{or}	dB	-14.2		-14.2		-14.2	
DPCH_Ec/I _{or}	dB	Note 1		N/A		N/A	
OCNS_Ec/I _{or}	dB	Note 2		-1.16		-1.16	
\hat{I}_{or}/I_{oc} (Note 3)	dB	0	5.42	-Infinity	3.9	-1.8	-1.8
\hat{I}_{or}	dBm	-70	-64.6	-Infinity	-66.10	-71.8	-71.8
I_{oc}	dBm/3.84 MHz	-70					
CPICH_Ec/I _o (Note 3)	dB	-12.21	-12.20	-Infinity	-13.70	-13.20	-13.20
Propagation Condition	AWGN						
Note 1:	The DPCH level is controlled by the power control loop.						
Note 2:	The power of the OCNS channel that is added shall make the total power from the cell to be equal to I_{or} .						
Note 3:	These parameters are not directly settable, but are derived by calculation from the settable parameters.						

NOTE: If the above Test Requirement differs from the Minimum Requirement then the Test Tolerance applied for this test is non-zero. The Test Tolerance for this test is defined in clause F.2 and the explanation of how the Minimum Requirement has been relaxed by the Test Tolerance is given in clause F.4.

8.6.2.2 Correct reporting of neighbours in fading propagation condition (Release 5 only)

8.6.2.2.1 Definition and applicability

In the event triggered reporting period the measurement reporting delay is defined as the time between any event that will trigger a measurement report until the UE starts to transmit the measurement report over the Uu interface. This requirement assumes that the measurement report is not delayed by other RRC signalling on the DCCH. This measurement reporting delay excludes a delay uncertainty resulted when inserting the measurement report to the TTI of the uplink DCCH. The delay uncertainty is twice the TTI of the uplink DCCH.

The requirements and this test apply for Release 5 only to all types of UTRA for the FDD UE. The requirements and this test apply for Release 5 and later releases to all types of UTRA for the FDD UE.

8.6.2.2.2 Minimum requirements

The requirements are the same as in sub clause 8.6.2.1.2.

The normative reference for these requirements is TS 25.133 [2] clauses 8.1.2.3 and A.8.2.2.

8.6.2.2.3 Test purpose

To verify that the UE meets the minimum requirements. The test is performed in fading propagation conditions.

8.6.2.2.4 Method of test

8.6.2.2.4.1 Initial conditions

Test environment: normal; see clauses G.2.1 and G.2.2.

Frequencies to be tested: mid range; see clause G.2.4.

The test parameters are given in table 8.6.2.2.4.1 and 8.6.2.2.4.2. In the measurement control information it is indicated to the UE that event-triggered reporting 2C shall be used. The test consists of two successive time periods, each with time duration of T1 and T2 respectively.

Table 8.6.2.2.4.1: General test parameters for correct reporting of neighbours in fading propagation condition

Parameter	Unit	Value	Comment
DCH parameters		DL Reference Measurement Channel 12.2 kbps	As specified in C.3.1 and C.2.1
Power Control		On	
Compressed mode		C.5.2 set 2 (TGPL1=12)	As specified in C.5
Active cell		Cell 1	
Absolute Threshold (Ec/NO) for Event 2C	dB	-18	
Hysteresis	dB	0	
Time to Trigger	ms	0	
Filter coefficient		0	
Monitored cell list size		Total 24 8 on frequency Channel 2	NOTE: See Annex I for cell information. The information is sent before the compressed mode pattern starts.
Propagation Condition		Case 5	As specified in Annex D
Frequency offset	ppm	+/- 0.1	Frequency offset between Cell 1 and Cell 2.
T1	s	2	
T2	s	40	

Table 8.6.2.2.4.2: Cell specific test parameters for correct reporting of neighbours in fading propagation condition

Parameter	Unit	Cell 1		Cell 2	
		T1	T2	T1	T2
UTRA RF Channel Number		Channel 1		Channel 2	
CPICH_Ec/I _{or}	dB	-10		-10	
PCCPCH_Ec/I _{or}	dB	-12		-12	
SCH_Ec/I _{or}	dB	-12		-12	
PICH_Ec/I _{or}	dB	-15		-15	
DPCH_Ec/I _{or}	dB	Note 1		N/A	
OCNS_Ec/I _{or}	dB	Note 2		-0.941	
\hat{I}_{or}/I_{oc}	dB	0		-Infinity	-1.8
\hat{I}_{or} (Note 3)	dBm	-70		-Infinity	-71.8
I_{oc}	dBm/3.84 MHz	-70		-70	
CPICH_Ec/I _o	dB	-13		-Infinity	-14
Propagation Condition		Case 5 as specified in Annex D			
Note 1: The DPCH level is controlled by the power control loop.					
Note 2: The power of the OCNS channel that is added shall make the total power from the cell to be equal to I _{or} .					
Note 3: The nominal \hat{I}_{or} values, although not explicitly defined in 25.133 [2] are added here since they are implied and need to be identified so that the test equipment can be configured.					

8.6.2.2.4.2 Procedure

- 1) The RF parameters are set up according to T1 in table 8.6.2.2.4.3.
- 2) The UE is switched on.
- 3) A call is set up in AWGN conditions, according to the test procedure specified in TS 34.108 [3] sub clause 7.3.2. The scrambling code is set to Cell2.
- 4) SS shall transmit a MEASUREMENT CONTROL message.
- 5) SS shall transmit PHYSICAL CHANNEL RECONFIGURATION message.

- 6) The fading simulator is switched on, configured with settings in table 8.6.2.2.4.3. T1 starts.
- 7) After 2 seconds from the beginning of T1, the SS shall switch the power settings from T1 to T2 according to the parameters defined in table 8.6.2.2.4.3.
- 8) UE shall transmit a MEASUREMENT REPORT message triggered by event 2C. The measurement reporting delay from the beginning of T2 shall be less than 36.4 s. If the UE fails to report the event within the required delay, then a failure is recorded. If the reporting delay for this event is within the required limit, the number of successful tests is increased by one.
- 9) After the SS receive the MEASUREMENT REPORT message in step 8) or 40 seconds after the beginning of T2, the SS shall transmits a RRC Connection Release message to make the UE to transit to idle mode.
- 10) SS shall sets the new primary code group and primary code on Cell2. Three different primary code groups and primary codes according to Annex I are used to turn on Cell2. Previous timing information of Cell 2 is invalid in the UE. The RF parameters are set up according to T1.
- 11) Repeat steps 3-10 until the confidence level is achieved according to Annex F.6.2 Table F.6.2.8.

Specific Message Contents

All messages indicated above shall use the same content as described in the default message content in clause 9 of 34.108 [3], with the following exceptions:

MEASUREMENT CONTROL message:

Information Element/Group name	Value/Remark
Message Type (10.2.17)	
UE information elements	
-RRC transaction identifier	0
-Integrity check info	
-message authentication code	SS calculates the value of MAC-I for this message and writes to this IE. The first/leftmost bit of the bit string contains the most significant bit of the MAC-I.
-RRC message sequence number	SS provides the value of this IE, from its internal counter.
Measurement Information elements	
-Measurement Identity	2
-Measurement Command (10.3.7.46)	Setup
-Measurement Reporting Mode (10.3.7.49)	
-Measurement Report Transfer Mode	AM RLC
-Periodical Reporting / Event Trigger Reporting Mode	Event trigger
-Additional measurements list (10.3.7.1)	Not Present
-CHOICE <i>Measurement type</i>	Inter-frequency measurement
-Inter-frequency measurement (10.3.7.16)	
-Inter-frequency measurement objects list (10.3.7.13)	
- CHOICE Inter-frequency cell removal	Not Present
- New Inter frequency cells	
- Inter frequency cell id	4
- Frequency info	
- CHOICE mode	FDD
- UARFCN uplink(Nu)	Not Present
- UARFCN downlink(Nd)	Same frequency as "Channel2" in Table 8.6.2.2.4.3
- Cell info	
- Cell individual offset	Not Present
- Reference time difference to cell	Not Present
- Read SFN indicator	FALSE
- CHOICE mode	FDD
- Primary CPICH info	
- Primary scrambling code	Set to Primary scrambling code of Cell2
- Primary CPICH Tx Power	Set to Primary CPICH Tx Power of Cell2 described in Table 8.6.2.2.4.3
- Tx Diversity Indicator	FALSE
- Cell for measurement	Not Present
-Inter-frequency measurement quantity (10.3.7.18)	
-CHOICE reporting criteria	Inter-frequency reporting criteria
-Filter coefficient (10.3.7.9)	0
-CHOICE mode	FDD
-Measurement quantity for frequency quality estimate	CPICH_Ec/N0
-Inter-frequency reporting quantity (10.3.7.21)	
-UTRA Carrier RSSI	FALSE
-Frequency quality estimate	FALSE
-Non frequency related cell reporting quantities (10.3.7.5)	
-Cell synchronisation information reporting indicator	TRUE (Note 1)
-Cell Identity reporting indicator	TRUE
-CHOICE mode	FDD
-CPICH Ec/N0 reporting indicator	TRUE
-CPICH RSCP reporting indicator	TRUE
-Pathloss reporting indicator	FALSE
-Reporting cell status (10.3.7.61)	Not Present
-Measurement validity (10.3.7.51)	Not Present
- Inter-frequency set update (10.3.7.22)	
-UE autonomous update mode	On with no reporting
-CHOICE report criteria	Inter-frequency measurement reporting criteria
-Inter-frequency measurement reporting criteria (10.3.7.19)	
-Parameters required for each event	1
-Inter-frequency event identity	Event 2C
-Threshold used frequency	Not present
-W used frequency	Not present

Information Element/Group name	Value/Remark
-Hysteresis -Time to trigger -Reporting cell status -CHOICE reported cell -Maximum number of reported cells -Parameters required for each non-used frequency -Threshold non used frequency -W non-used frequency	0 dB 0 ms Report cells within monitored and/or virtual active set on non-used frequency 3 -18 dB 1
Physical channel information elements -DPCH compressed mode status info (10.3.6.34)	Not Present
Note 1: The SFN-CFN observed time difference is calculated from the OFF and Tm parameters contained in the IE "Cell synchronisation information", TS 25.331, clause 10.3.7.6. According to TS 25.331, 8.6.7.7, this IE is included in MEASUREMENT REPORT if IE "Cell synchronisation information reporting indicator" in IE "Cell reporting quantities" TS 25.331, clause 10.3.7.5 is set to TRUE in MEASUREMENT CONTROL.	

PHYSICAL CHANNEL RECONFIGURATION message for Inter frequency measurement:

Information Element	Value/Remark	Version
Message Type		
UE Information Elements		
-RRC transaction identifier	0	
-Integrity check info		
-message authentication code	SS calculates the value of MAC-I for this message and writes to this IE. The first/leftmost bit of the bit string contains the most significant bit of the MAC-I.	
-RRC message sequence number	SS provides the value of this IE, from its internal counter.	
-Integrity protection mode info	Not Present	
-Ciphering mode info	Not Present	
-Activation time	Not Present	
-New U-RNTI	Not Present	
-New C-RNTI	Not Present	
-RRC State Indicator	CELL_DCH	
-UTRAN DRX cycle length coefficient	Not Present	
CN Information Elements		
-CN Information info	Not Present	
UTRAN mobility information elements		
-URA identity	Not Present	
RB information elements		
-Downlink counter synchronisation info	Not Present	
PhyCH information elements		
-Frequency info	Not Present	
Uplink radio resources		
-Maximum allowed UL TX power	33 dBm	
Downlink radio resources		
-CHOICE mode	FDD	
-Downlink PDSCH information	Not Present	R99 and Rel-4 only
-Downlink information common for all radio links (10.3.6.24)		
-Downlink DPCH info common for all RL (10.3.6.18)	Not Present	
-CHOICE mode	FDD	
-DPCH compressed mode info (10.3.6.33)		
-Transmission gap pattern sequence		
-TGPSI	1	
-TGPS Status Flag	Activate	
-TGCFN	(Current CFN + (256 – TTI/10msec))mod 256	
-Transmission gap pattern sequence configuration parameters		
-TGMP	FDD measurement	
-TGPRC	Infinity	
-TGSN	4	
-TGL1	7	
-TGL2	Not Present	
-TGD	UNDEFINED	
-TGPL1	12	
-TGPL2	Not Present	R99 and Rel-4 only
-RPP	Mode 0	
-ITP	Mode 0	
-CHOICE UL/DL mode	UL and DL	
-Downlink compressed mode method	SF/2	
-Uplink compressed mode method	SF/2	
-Downlink frame type	B	
-DeltaSIR1	3.0	
-DeltaSIRafter1	3.0	
-DeltaSIR2	Not Present	
-DeltaSIRafter2	Not Present	
-N Identify abort	Not Present	
-T Reconfirm abort	Not Present	
-TX Diversity mode (10.3.6.86)	Not Present	
-SSDT information (10.3.6.77)	Not Present	R99 and Rel-4 only
-Default DPCH Offset Value (10.3.6.16)	Not Present	

Information Element	Value/Remark	Version
-Downlink information per radio link list		
-Downlink information for each radio link (10.3.6.27)		
-CHOICE mode	FDD	
-Primary CPICH info (10.3.6.60)	100	R99 and Rel-4 only
-Primary scrambling code	Not Present	R99 and Rel-4 only
-PDSCH with SHO DCH info (10.3.6.47)	Not Present	
-PDSCH code mapping (10.3.6.43)	Not Present	
-Downlink DPCH info for each RL (10.3.6.21)		
-CHOICE mode	FDD	
-Primary CPICH usage for channel estimation	Primary CPICH may be used	
-DPCH frame offset	Set to value Default DPCH Offset Value (as currently stored in SS) mod 38400	
-Secondary CPICH info	Not Present	
-DL channelisation code	Not Present	
-Secondary scrambling code	Not Present	
-Spreading factor	128	
-Code number	96	
-Scrambling code change	No code change	
-TPC combination index	0	
-SSDT Cell Identity	Not Present	R99 and Rel-4 only
- Closed loop timing adjustment mode	Not Present	
- SCCPCH information for FACH (10.3.6.70)	Not Present	

MEASUREMENT REPORT message for Inter frequency test cases

These messages are common for all inter frequency test cases and are described in Annex I.

8.6.2.2.5 Test requirements

For the test to pass, the total number of successful tests shall be at least 90% of the cases with a confidence level of 95% According to annex F.6.2. The number of successful tests shall be on an event level, i.e. the SS shall check how many events are reported successfully out of the total number of events checked.

Table 8.6.2.2.4.3: Test requirements for correct reporting of neighbours in fading propagation condition

Parameter	Unit	Cell 1		Cell 2	
		T1	T2	T1	T2
UTRA RF Channel Number		Channel 1		Channel 2	
CPICH_Ec/lor	dB	-9.2		-9.2	
PCCPCH_Ec/lor	dB	-11.2		-11.2	
SCH_Ec/lor	dB	-11.2		-11.2	
PICH_Ec/lor	dB	-14.2		-14.2	
DPCH_Ec/lor	dB	Note 1		N/A	
OCNS_Ec/lor	dB	Note 2		-1.16	
\hat{I}_{or}/I_{oc} (Note 3)	dB	0		-Infinity	-1.8
\hat{I}_{or}	dBm	-70		-Infinity	-71.8
I_{oc}	dBm/3.84 MHz	-70			
CPICH_Ec/lor (Note 3)	dB	-12.21		-Infinity	-13.2
Propagation Condition	Case 5 as specified in Annex D				
Note 1:	The DPCH level is controlled by the power control loop.				
Note 2:	The power of the OCNS channel that is added shall make the total power from the cell to be equal to I_{or} .				
Note 3:	These parameters are not directly settable, but are derived by calculation from the settable parameters.				

NOTE: If the above Test Requirement differs from the Minimum Requirement then the Test Tolerance applied for this test is non-zero. The Test Tolerance for this test is defined in clause F.2 and the explanation of how the Minimum Requirement has been relaxed by the Test Tolerance is given in clause F.4.

8.6.2.2A Correct reporting of neighbours in fading propagation condition (Release 6 and later)

8.6.2.2A.1 Definition and applicability

In the event triggered reporting period the measurement reporting delay is defined as the time between any event that will trigger a measurement report until the UE starts to transmit the measurement report over the Uu interface. This requirement assumes that the measurement report is not delayed by other RRC signalling on the DCCH. This measurement reporting delay excludes a delay uncertainty resulted when inserting the measurement report to the TTI of the uplink DCCH. The delay uncertainty is twice the TTI of the uplink DCCH.

The requirements and this test apply for Release 6 and later releases to all types of UTRA for the FDD UE.

8.6.2.2A.2 Minimum requirements

The requirements are the same as in sub clause 8.6.2.1A.2.

The normative reference for these requirements is TS 25.133 [2] clauses 8.1.2.3 and A.8.2.2.

8.6.2.2A.3 Test purpose

To verify that the UE meets the minimum requirements. The test is performed in fading propagation conditions.

8.6.2.2A.4 Method of test

8.6.2.2A.4.1 Initial conditions

Test environment: normal; see clauses G.2.1 and G.2.2.

Frequencies to be tested: mid range; see clause G.2.4.

The test parameters are given in table 8.6.2.2A.4.1 and 8.6.2.2A.4.2. In the measurement control information it is indicated to the UE that event-triggered reporting 2C shall be used. The test consists of two successive time periods, each with time duration of T1 and T2 respectively.

Table 8.6.2.2A.4.1: General test parameters for correct reporting of neighbours in fading propagation condition

Parameter	Unit	Value	Comment
DCH parameters		DL Reference Measurement Channel 12.2 kbps	As specified in C.3.1 and C.2.1
Power Control		On	
Compressed mode		C.5.2 set 2 (TGPL1=12)	As specified in C.5
Active cell		Cell 1	
Absolute Threshold (Ec/NO) for Event 2C	dB	-18	
Hysteresis	dB	0	
Time to Trigger	ms	0	
Filter coefficient		0	
Monitored cell list size		Total 24 8 on frequency Channel 2	NOTE: See Annex I for cell information. The information is sent before the compressed mode pattern starts.
Propagation Condition		Case 5	As specified in Annex D
Frequency offset	ppm	+/- 0.1	Frequency offset between Cell 1 and Cell 2.
T1	s	2	
T2	s	15	

Table 8.6.2.2A.4.2: Cell specific test parameters for correct reporting of neighbours in fading propagation condition

Parameter	Unit	Cell 1		Cell 2	
		T1	T2	T1	T2
UTRA RF Channel Number		Channel 1		Channel 2	
CPICH_Ec/I _{or}	dB	-10		-10	
PCCPCH_Ec/I _{or}	dB	-12		-12	
SCH_Ec/I _{or}	dB	-12		-12	
PICH_Ec/I _{or}	dB	-15		-15	
DPCH_Ec/I _{or}	dB	Note 1		N/A	
OCNS_Ec/I _{or}	dB	Note 2		-0.941	
\hat{I}_{or}/I_{oc}	dB	0		-Infinity	-1.8
\hat{I}_{or} (Note 3)	dBm	-70		-Infinity	-71.8
I_{oc}	dBm/3.84 MHz	-70		-70	
CPICH_Ec/I _o	dB	-13		-Infinity	-14
Propagation Condition		Case 5 as specified in Annex D			
Note 1: The DPCH level is controlled by the power control loop.					
Note 2: The power of the OCNS channel that is added shall make the total power from the cell to be equal to I_{or} .					
Note 3: The nominal \hat{I}_{or} values, although not explicitly defined in 25.133 [2] are added here since they are implied and need to be identified so that the test equipment can be configured.					

8.6.2.2A.4.2 Procedure

- 1) The RF parameters are set up according to T1 in table 8.6.2.2A.4.3.
- 2) The UE is switched on.
- 3) A call is set up in AWGN conditions, according to the test procedure specified in TS 34.108 [3] sub clause 7.3.2. The scrambling code is set to Cell2.
- 4) SS shall transmit a MEASUREMENT CONTROL message.
- 5) SS shall transmit PHYSICAL CHANNEL RECONFIGURATION message.
- 6) The fading simulator is switched on, configured with settings in table 8.6.2.2A.4.3. T1 starts.
- 7) After 2 seconds from the beginning of T1, the SS shall switch the power settings from T1 to T2 according to the parameters defined in table 8.6.2.2A.4.3.
- 8) UE shall transmit a MEASUREMENT REPORT message triggered by event 2C. The measurement reporting delay from the beginning of T2 shall be less than [13.9] seconds. If the UE fails to report the event within the required delay, then a failure is recorded. If the reporting delay for this event is within the required limit, the number of successful tests is increased by one.
- 9) After the SS receive the MEASUREMENT REPORT message in step 8) or 15 seconds after the beginning of T2, the SS shall transmits a RRC Connection Release message to make the UE to transit to idle mode.
- 10) SS shall sets the new primary code group and primary code on Cell2. Three different primary code groups and primary codes according to Annex I are used to turn on Cell2. Previous timing information of Cell 2 is invalid in the UE. The RF parameters are set up according to T1.
- 11) Repeat steps 3-10 until the confidence level is achieved according to Annex F.6.2 Table F.6.2.8.

Specific Message Contents

All messages indicated above shall use the same content as described in the default message content in clause 9 of 34.108 [3], with the following exceptions:

MEASUREMENT CONTROL message:

Information Element/Group name	Value/Remark
Message Type (10.2.17)	
UE information elements	
-RRC transaction identifier	0
-Integrity check info	
-message authentication code	SS calculates the value of MAC-I for this message and writes to this IE. The first/leftmost bit of the bit string contains the most significant bit of the MAC-I.
-RRC message sequence number	SS provides the value of this IE, from its internal counter.
Measurement Information elements	
-Measurement Identity	2
-Measurement Command (10.3.7.46)	Setup
-Measurement Reporting Mode (10.3.7.49)	
-Measurement Report Transfer Mode	AM RLC
-Periodical Reporting / Event Trigger Reporting Mode	Event trigger
-Additional measurements list (10.3.7.1)	Not Present
-CHOICE <i>Measurement type</i>	Inter-frequency measurement
-Inter-frequency measurement (10.3.7.16)	
-Inter-frequency measurement objects list (10.3.7.13)	
- CHOICE Inter-frequency cell removal	Not Present
- New Inter frequency cells	
- Inter frequency cell id	4
- Frequency info	
- CHOICE mode	FDD
- UARFCN uplink(Nu)	Not Present
- UARFCN downlink(Nd)	Same frequency as "Channel2" in Table 8.6.2.2.4.3
- Cell info	
- Cell individual offset	Not Present
- Reference time difference to cell	Not Present
- Read SFN indicator	FALSE
- CHOICE mode	FDD
- Primary CPICH info	
- Primary scrambling code	Set to Primary scrambling code of Cell2
- Primary CPICH Tx Power	Set to Primary CPICH Tx Power of Cell2 described in Table 8.6.2.2.4.3
- Tx Diversity Indicator	FALSE
- Cell for measurement	Not Present
-Inter-frequency measurement quantity (10.3.7.18)	
-CHOICE reporting criteria	Inter-frequency reporting criteria
-Filter coefficient (10.3.7.9)	0
-CHOICE mode	FDD
-Measurement quantity for frequency quality estimate	CPICH_Ec/N0
-Inter-frequency reporting quantity (10.3.7.21)	
-UTRA Carrier RSSI	FALSE
-Frequency quality estimate	FALSE
-Non frequency related cell reporting quantities (10.3.7.5)	
-Cell synchronisation information reporting indicator	TRUE (Note 1)
-Cell Identity reporting indicator	TRUE
-CHOICE mode	FDD
-CPICH Ec/N0 reporting indicator	TRUE
-CPICH RSCP reporting indicator	TRUE
-Pathloss reporting indicator	FALSE
-Reporting cell status (10.3.7.61)	Not Present
-Measurement validity (10.3.7.51)	Not Present
- Inter-frequency set update (10.3.7.22)	
-UE autonomous update mode	On with no reporting
-CHOICE report criteria	Inter-frequency measurement reporting criteria
-Inter-frequency measurement reporting criteria (10.3.7.19)	
-Parameters required for each event	1
-Inter-frequency event identity	Event 2C
-Threshold used frequency	Not present
-W used frequency	Not present

Information Element/Group name	Value/Remark
-Hysteresis -Time to trigger -Reporting cell status -CHOICE reported cell -Maximum number of reported cells -Parameters required for each non-used frequency -Threshold non used frequency -W non-used frequency	0 dB 0 ms Report cells within monitored and/or virtual active set on non-used frequency 3 -18 dB 1
Physical channel information elements -DPCH compressed mode status info (10.3.6.34)	Not Present
Note 1: The SFN-CFN observed time difference is calculated from the OFF and Tm parameters contained in the IE "Cell synchronisation information", TS 25.331, clause 10.3.7.6. According to TS 25.331, 8.6.7.7, this IE is included in MEASUREMENT REPORT if IE "Cell synchronisation information reporting indicator" in IE "Cell reporting quantities" TS 25.331, clause 10.3.7.5 is set to TRUE in MEASUREMENT CONTROL.	

PHYSICAL CHANNEL RECONFIGURATION message for Inter frequency measurement:

Information Element	Value/Remark	Version
Message Type		
UE Information Elements		
-RRC transaction identifier	0	
-Integrity check info		
-message authentication code	SS calculates the value of MAC-I for this message and writes to this IE. The first/leftmost bit of the bit string contains the most significant bit of the MAC-I.	
-RRC message sequence number	SS provides the value of this IE, from its internal counter.	
-Integrity protection mode info	Not Present	
-Ciphering mode info	Not Present	
-Activation time	Not Present	
-New U-RNTI	Not Present	
-New C-RNTI	Not Present	
-RRC State Indicator	CELL_DCH	
-UTRAN DRX cycle length coefficient	Not Present	
CN Information Elements		
-CN Information info	Not Present	
UTRAN mobility information elements		
-URA identity	Not Present	
RB information elements		
-Downlink counter synchronisation info	Not Present	
PhyCH information elements		
-Frequency info	Not Present	
Uplink radio resources		
-Maximum allowed UL TX power	33 dBm	
Downlink radio resources		
-CHOICE mode	FDD	
-Downlink PDSCH information	Not Present	R99 and Rel-4 only
-Downlink information common for all radio links (10.3.6.24)		
-Downlink DPCH info common for all RL (10.3.6.18)	Not Present	
-CHOICE mode	FDD	
-DPCH compressed mode info (10.3.6.33)		
-Transmission gap pattern sequence		
-TGPSI	1	
-TGPS Status Flag	Activate	
-TGCFN	(Current CFN + (256 – TTI/10msec))mod 256	
-Transmission gap pattern sequence configuration parameters		
-TGMP	FDD measurement	
-TGPRC	Infinity	
-TGSN	4	
-TGL1	7	
-TGL2	Not Present	
-TGD	UNDEFINED	
-TGPL1	12	
-TGPL2	Not Present	R99 and Rel-4 only
-RPP	Mode 0	
-ITP	Mode 0	
-CHOICE UL/DL mode	UL and DL	
-Downlink compressed mode method	SF/2	
-Uplink compressed mode method	SF/2	
-Downlink frame type	B	
-DeltaSIR1	3.0	
-DeltaSIRafter1	3.0	
-DeltaSIR2	Not Present	
-DeltaSIRafter2	Not Present	
-N Identify abort	Not Present	
-T Reconfirm abort	Not Present	
-TX Diversity mode (10.3.6.86)	Not Present	
-SSDT information (10.3.6.77)	Not Present	R99 and Rel-4 only
-Default DPCH Offset Value (10.3.6.16)	Not Present	

Information Element	Value/Remark	Version
-Downlink information per radio link list		
-Downlink information for each radio link (10.3.6.27)		
-CHOICE mode	FDD	
-Primary CPICH info (10.3.6.60)		
-Primary scrambling code	100	
-PDSCH with SHO DCH info (10.3.6.47)	Not Present	R99 and Rel-4 only
-PDSCH code mapping (10.3.6.43)	Not Present	R99 and Rel-4 only
-Downlink DPCH info for each RL (10.3.6.21)		
-CHOICE mode	FDD	
-Primary CPICH usage for channel estimation	Primary CPICH may be used	
-DPCH frame offset	Set to value Default DPCH Offset Value (as currently stored in SS) mod 38400	
-Secondary CPICH info	Not Present	
-DL channelisation code		
-Secondary scrambling code	Not Present	
-Spreading factor	128	
-Code number	96	
-Scrambling code change	No code change	
-TPC combination index	0	
-SSDT Cell Identity	Not Present	R99 and Rel-4 only
- Closed loop timing adjustment mode	Not Present	
- SCCPCH information for FACH (10.3.6.70)	Not Present	

MEASUREMENT REPORT message for Inter frequency test cases

These messages are common for all inter frequency test cases and are described in Annex I.

8.6.2.2A.5 Test requirements

For the test to pass, the total number of successful tests shall be at least 90% of the cases with a confidence level of 95% According to annex F.6.2. The number of successful tests shall be on an event level, i.e. the SS shall check how many events are reported successfully out of the total number of events checked.

Table 8.6.2.2A.4.3: Test requirements for correct reporting of neighbours in fading propagation condition

Parameter	Unit	Cell 1		Cell 2	
		T1	T2	T1	T2
UTRA RF Channel Number		Channel 1		Channel 2	
CPICH_Ec/lor	dB	-9.2		-9.2	
PCCPCH_Ec/lor	dB	-11.2		-11.2	
SCH_Ec/lor	dB	-11.2		-11.2	
PICH_Ec/lor	dB	-14.2		-14.2	
DPCH_Ec/lor	dB	Note 1		N/A	
OCNS_Ec/lor	dB	Note 2		-1.16	
\hat{I}_{or} / I_{oc} (Note 3)	dB	0		-Infinity	-1.8
\hat{I}_{or}	dBm	-70		-Infinity	-71.8
I_{oc}	dBm/3.84 MHz	-70			
CPICH_Ec/lor (Note 3)	dB	-12.21		-Infinity	-13.2
Propagation Condition	Case 5 as specified in Annex D				
Note 1: The DPCH level is controlled by the power control loop.					
Note 2: The power of the OCNS channel that is added shall make the total power from the cell to be equal to I_{or} .					
Note 3: These parameters are not directly settable, but are derived by calculation from the settable parameters.					

NOTE: If the above Test Requirement differs from the Minimum Requirement then the Test Tolerance applied for this test is non-zero. The Test Tolerance for this test is defined in clause F.2 and the explanation of how the Minimum Requirement has been relaxed by the Test Tolerance is given in clause F.4.

8.6.2.3 Correct reporting of neighbours in fading propagation condition using TGL1=14

8.6.2.3.1 Definition and applicability

In the event triggered reporting period the measurement reporting delay is defined as the time between any event that will trigger a measurement report until the UE starts to transmit the measurement report over the Uu interface. This requirement assumes that the measurement report is not delayed by other RRC signalling on the DCCH. This measurement reporting delay excludes a delay uncertainty resulted when inserting the measurement report to the TTI of the uplink DCCH. The delay uncertainty is twice the TTI of the uplink DCCH.

The requirements and this test apply for Release 6 and later releases to all types of UTRA for the FDD UE.

8.6.2.3.2 Minimum requirements

The requirements are the same as in sub clause 8.6.2.1.2.

The normative reference for these requirements is TS 25.133 [2] clauses 8.1.2.3 and A.8.2.3.

8.6.2.3.3 Test purpose

To verify that the UE meets the minimum requirements. The test is performed in fading propagation conditions using TGL1=14.

8.6.2.3.4 Method of test

8.6.2.3.4.1 Initial conditions

Test environment: normal; see clauses G.2.1 and G.2.2.

Frequencies to be tested: mid range; see clause G.2.4.

The test parameters are given in table 8.6.2.3.4.1 and 8.6.2.3.4.2. In the measurement control information it is indicated to the UE that event-triggered reporting 2C shall be used. The test consists of two successive time periods, each with time duration of T1 and T2 respectively.

Table 8.6.2.3.4.1: General test parameters for correct reporting of neighbours in fading propagation condition using TGL1=14

Parameter	Unit	Value	Comment
DCH parameters		DL Reference Measurement Channel 12.2 kbps	As specified in C.3.1 and C.2.1
Power Control		On	
Compressed mode		C.5.2 set 4 (TGPL1=4)	As specified in C.5
Active cell		Cell 1	
Absolute Threshold (Ec/NO) for Event 2C	dB	-18	
Hysteresis	dB	0	
Time to Trigger	ms	0	
Filter coefficient		0	
Monitored cell list size		Total 24 8 on frequency Channel 2	NOTE: See Annex I for cell information. The information is sent before the compressed mode pattern starts.
Propagation Condition		Case 5	As specified in Annex D
Frequency offset	ppm	+/- 0.1	Frequency offset between Cell 1 and Cell 2.
T1	s	2	
T2	s	2	

Table 8.6.2.3.4.2: Cell specific test parameters for correct reporting of neighbours in fading propagation condition using TGL1=14

Parameter	Unit	Cell 1		Cell 2	
		T1	T2	T1	T2
UTRA RF Channel Number		Channel 1		Channel 2	
CPICH_Ec/I _{or}	dB	-10		-10	
PCCPCH_Ec/I _{or}	dB	-12		-12	
SCH_Ec/I _{or}	dB	-12		-12	
PICH_Ec/I _{or}	dB	-15		-15	
DPCH_Ec/I _{or}	dB	Note 1		N/A	
OCNS		Note 2		-0.941	
\hat{I}_{or}/I_{oc}	dB	0		-Infinity	-1.8
$\hat{I}_{or} (Note\ 3)$	dB	-70		-Infinity	-71.8
I_{oc}	dBm/3.84 MHz	-70		-70	
CPICH_Ec/I _o	dB	-13		-Infinity	-14
Propagation Condition	Case 5 as specified in Annex D				
Note 1:	The DPCH level is controlled by the power control loop				
Note 2:	The power of the OCNS channel that is added shall make the total power from the cell to be equal to I _{or} .				
Note 3:	The nominal I _{or} values, although not explicitly defined in 25.133 [2] are added here since they are implied and need to be identified so that the test equipment can be configured.				

8.6.2.3.4.2 Procedure

- 1) The RF parameters are set up according to T1 in table 8.6.2.3.4.3.
- 2) The UE is switched on.
- 3) A call is set up in AWGN conditions, according to the test procedure specified in TS 34.108 [3] sub clause 7.3.2. The scrambling code is set to Cell2.
- 4) SS shall transmit a MEASUREMENT CONTROL message.
- 5) SS shall transmit PHYSICAL CHANNEL RECONFIGURATION message.
- 6) The fading simulator is switched on, configured with settings in table 8.6.2.3.4.3. T1 starts.
- 7) After 2 seconds from the beginning of T1, the SS shall switch the power settings from T1 to T2 according to the parameters defined in table 8.6.2.3.4.3.
- 8) UE shall transmit a MEASUREMENT REPORT message triggered by event 2C. The measurement reporting delay from the beginning of T2 shall be less than [1.78] seconds. If the UE fails to report the event within the required delay, then a failure is recorded. If the reporting delay for this event is within the required limit, the number of successful tests is increased by one.
- 9) After the SS receive the MEASUREMENT REPORT message in step 8) or 2 seconds after the beginning of T2, the SS shall transmits a RRC Connection Release message to make the UE to transit to idle mode.
- 10) SS shall sets the new primary code group and primary code on Cell2. Three different primary code groups and primary codes according to Annex I are used to turn on Cell2. Previous timing information of Cell 2 is invalid in the UE. The RF parameters are set up according to T1.
- 11) Repeat steps 3-10 until the confidence level is achieved according to Annex F.6.2 Table F.6.2.8.

Specific Message Contents

All messages indicated above shall use the same content as described in the default message content in clause 9 of 34.108 [3], with the following exceptions:

MEASUREMENT CONTROL message:

Information Element/Group name	Value/Remark
Message Type (10.2.17)	
UE information elements	
-RRC transaction identifier	0
-Integrity check info	
-message authentication code	SS calculates the value of MAC-I for this message and writes to this IE. The first/leftmost bit of the bit string contains the most significant bit of the MAC-I.
-RRC message sequence number	SS provides the value of this IE, from its internal counter.
Measurement Information elements	
-Measurement Identity	2
-Measurement Command (10.3.7.46)	Setup
-Measurement Reporting Mode (10.3.7.49)	
-Measurement Report Transfer Mode	AM RLC
-Periodical Reporting / Event Trigger Reporting Mode	Event trigger
-Additional measurements list (10.3.7.1)	Not Present
-CHOICE <i>Measurement type</i>	Inter-frequency measurement
-Inter-frequency measurement (10.3.7.16)	
-Inter-frequency measurement objects list (10.3.7.13)	
- CHOICE Inter-frequency cell removal	Not Present
- New Inter frequency cells	
- Inter frequency cell id	4
- Frequency info	
- CHOICE mode	FDD
- UARFCN uplink(Nu)	Not Present
- UARFCN downlink(Nd)	Same frequency as "Channel2" in Table 8.6.2.3.4.3
- Cell info	
- Cell individual offset	Not Present
- Reference time difference to cell	Not Present
- Read SFN indicator	FALSE
- CHOICE mode	FDD
- Primary CPICH info	
- Primary scrambling code	Set to Primary scrambling code of Cell2
- Primary CPICH Tx Power	Set to Primary CPICH Tx Power of Cell2 described in Table 8.6.2.3.4.3
- Tx Diversity Indicator	FALSE
- Cell for measurement	Not Present
-Inter-frequency measurement quantity (10.3.7.18)	
-CHOICE reporting criteria	Inter-frequency reporting criteria
-Filter coefficient (10.3.7.9)	0
-CHOICE mode	FDD
-Measurement quantity for frequency quality estimate	CPICH_Ec/N0
-Inter-frequency reporting quantity (10.3.7.21)	
-UTRA Carrier RSSI	FALSE
-Frequency quality estimate	FALSE
-Non frequency related cell reporting quantities (10.3.7.5)	
-Cell synchronisation information reporting indicator	TRUE (Note 1)
-Cell Identity reporting indicator	TRUE
-CHOICE mode	FDD
-CPICH Ec/N0 reporting indicator	TRUE
-CPICH RSCP reporting indicator	TRUE
-Pathloss reporting indicator	FALSE
-Reporting cell status (10.3.7.61)	Not Present
-Measurement validity (10.3.7.51)	Not Present
- Inter-frequency set update (10.3.7.22)	
-UE autonomous update mode	On with no reporting
-CHOICE report criteria	Inter-frequency measurement reporting criteria
-Inter-frequency measurement reporting criteria (10.3.7.19)	
-Parameters required for each event	1
-Inter-frequency event identity	Event 2C
-Threshold used frequency	Not present
-W used frequency	Not present

Information Element/Group name	Value/Remark
-Hysteresis -Time to trigger -Reporting cell status -CHOICE reported cell -Maximum number of reported cells -Parameters required for each non-used frequency -Threshold non used frequency -W non-used frequency	0 dB 0 ms Report cells within monitored and/or virtual active set on non-used frequency 3 -18 dB 1
Physical channel information elements -DPCH compressed mode status info (10.3.6.34)	Not Present
Note 1: The SFN-CFN observed time difference is calculated from the OFF and Tm parameters contained in the IE "Cell synchronisation information", TS 25.331, clause 10.3.7.6. According to TS 25.331, 8.6.7.7, this IE is included in MEASUREMENT REPORT if IE "Cell synchronisation information reporting indicator" in IE "Cell reporting quantities" TS 25.331, clause 10.3.7.5 is set to TRUE in MEASUREMENT CONTROL.	

PHYSICAL CHANNEL RECONFIGURATION message for Inter frequency measurement:

Information Element	Value/Remark	Version
Message Type		
UE Information Elements		
-RRC transaction identifier	0	
-Integrity check info		
-message authentication code	SS calculates the value of MAC-I for this message and writes to this IE. The first/leftmost bit of the bit string contains the most significant bit of the MAC-I.	
-RRC message sequence number	SS provides the value of this IE, from its internal counter.	
-Integrity protection mode info	Not Present	
-Ciphering mode info	Not Present	
-Activation time	Not Present	
-New U-RNTI	Not Present	
-New C-RNTI	Not Present	
-RRC State Indicator	CELL_DCH	
-UTRAN DRX cycle length coefficient	Not Present	
CN Information Elements		
-CN Information info	Not Present	
UTRAN mobility information elements		
-URA identity	Not Present	
RB information elements		
-Downlink counter synchronisation info	Not Present	
PhyCH information elements		
-Frequency info	Not Present	
Uplink radio resources		
-Maximum allowed UL TX power	33 dBm	
Downlink radio resources		
-CHOICE mode	FDD	
-Downlink PDSCH information	Not Present	R99 and Rel-4 only
-Downlink information common for all radio links (10.3.6.24)		
-Downlink DPCH info common for all RL (10.3.6.18)	Not Present	
-CHOICE mode	FDD	
-DPCH compressed mode info (10.3.6.33)		
-Transmission gap pattern sequence		
-TGPSI	1	
-TGPS Status Flag	Activate	
-TGCFN	(Current CFN + (256 – TTI/10msec))mod 256	
-Transmission gap pattern sequence configuration parameters		
-TGMP	FDD measurement	
-TGPRC	Infinity	
-TGSN	8	
-TGL1	14	
-TGL2	Not Present	
-TGD	UNDEFINED	
-TGPL1	4	
-TGPL2	Not Present	R99 and Rel-4 only
-RPP	Mode 0	
-ITP	Mode 0	
-CHOICE UL/DL mode	UL and DL	
-Downlink compressed mode method	SF/2	
-Uplink compressed mode method	SF/2	
-Downlink frame type	B	
-DeltaSIR1	3.0	
-DeltaSIRafter1	3.0	
-DeltaSIR2	Not Present	
-DeltaSIRafter2	Not Present	
-N Identify abort	Not Present	
-T Reconfirm abort	Not Present	
-TX Diversity mode (10.3.6.86)	Not Present	
-SSDT information (10.3.6.77)	Not Present	R99 and Rel-4 only
-Default DPCH Offset Value (10.3.6.16)	Not Present	

Information Element	Value/Remark	Version
-Downlink information per radio link list		
-Downlink information for each radio link (10.3.6.27)		
-CHOICE mode	FDD	
-Primary CPICH info (10.3.6.60)	100	R99 and Rel-4 only
-Primary scrambling code	Not Present	R99 and Rel-4 only
-PDSCH with SHO DCH info (10.3.6.47)	Not Present	
-PDSCH code mapping (10.3.6.43)	Not Present	
-Downlink DPCH info for each RL (10.3.6.21)		
-CHOICE mode	FDD	
-Primary CPICH usage for channel estimation	Primary CPICH may be used	
-DPCH frame offset	Set to value Default DPCH Offset Value (as currently stored in SS) mod 38400	
-Secondary CPICH info	Not Present	
-DL channelisation code	Not Present	
-Secondary scrambling code	Not Present	
-Spreading factor	128	
-Code number	96	
-Scrambling code change	No code change	
-TPC combination index	0	
-SSDT Cell Identity	Not Present	R99 and Rel-4 only
- Closed loop timing adjustment mode	Not Present	
- SCCPCH information for FACH (10.3.6.70)	Not Present	

MEASUREMENT REPORT message for Inter frequency test cases

These messages are common for all inter frequency test cases and are described in Annex I.

8.6.2.3.5 Test requirements

For the test to pass, the total number of successful tests shall be at least 90% of the cases with a confidence level of 95% According to annex F.6.2. The number of successful tests shall be on an event level, i.e. the SS shall check how many events are reported successfully out of the total number of events checked.

Table 8.6.2.3.4.3: Test requirements for correct reporting of neighbours in fading propagation condition

Parameter	Unit	Cell 1		Cell 2	
		T1	T2	T1	T2
UTRA RF Channel Number		Channel 1		Channel 2	
CPICH_Ec/lor	dB	-9.2		-9.2	
PCCPCH_Ec/lor	dB	-11.2		-11.2	
SCH_Ec/lor	dB	-11.2		-11.2	
PICH_Ec/lor	dB	-14.2		-14.2	
DPCH_Ec/lor	dB	Note 1		N/A	
OCNS_Ec/lor	dB	Note 2		-1.16	
\hat{I}_{or}/I_{oc} (Note 3)	dB	0		-Infinity	-1.8
\hat{I}_{or}	dBm	-70		-Infinity	-71.8
I_{oc}	dBm/3.84 MHz	-70			
CPICH_Ec/lor (Note 3)	dB	-12.21		-Infinity	-13.2
Propagation Condition	Case 5 as specified in Annex D				
Note 1:	The DPCH level is controlled by the power control loop.				
Note 2:	The power of the OCNS channel that is added shall make the total power from the cell to be equal to I_{or} .				
Note 3:	These parameters are not directly settable, but are derived by calculation from the settable parameters.				

NOTE: If the above Test Requirement differs from the Minimum Requirement then the Test Tolerance applied for this test is non-zero. The Test Tolerance for this test is defined in clause F.2 and the explanation of how the Minimum Requirement has been relaxed by the Test Tolerance is given in clause F.4.

8.6.3 TDD measurements

8.6.3.1 Correct reporting of TDD neighbours in AWGN propagation condition

8.6.3.1.1 Definition and applicability

In the event triggered reporting period the measurement reporting delay is defined as the time between any event that will trigger a measurement report until the UE starts to transmit over the Uu interface. This requirement assumes that the measurement report is not delayed by other RRC signalling on the DCCH. This measurement reporting delay excludes a delay uncertainty resulted when inserting the measurement report to the TTI of the uplink DCCH. The delay uncertainty is twice the TTI of the uplink DCCH.

The requirements and this test apply to the combined FDD and TDD UE for Release 99 and Release 4 only.

8.6.3.1.2 Minimum requirement

8.6.3.1.2.1 3.84Mcps TDD option

When transmission gaps are scheduled for inter-frequency TDD measurements, the UE shall be able to identify a new detectable inter-frequency TDD cell belonging to the monitored set within

$$T_{\text{identify TDD inter}} = \text{Max} \left\{ 5000, N_{\text{basic identify TDD inter}} \cdot \frac{T_{\text{Measurement Period TDD inter}}}{N_{\text{TDD inter}}} \cdot N_{\text{Freq}} \right\} \text{ms}$$

If the UE does not need compressed mode to perform inter-frequency TDD measurements, the UE shall be able to identify a new detectable inter-frequency TDD cell belonging to the monitored set within 5000 ms.

An inter-frequency TDD cell shall be considered detectable when P-CCPCH Ec/Io ≥ -8 dB and SCH_Ec/Io ≥ -13 dB. When L3 filtering is used an additional delay can be expected.

When transmission gaps are scheduled for inter frequency TDD measurements the UE physical layer shall be capable of reporting measurements to higher layers with a measurement period as given by

$$T_{\text{measurement TDD inter}} = \text{Max} \left\{ T_{\text{Measurement Period TDD inter}}, N_{\text{basic measurement TDD inter}} \cdot \frac{T_{\text{Measurement Period TDD inter}}}{N_{\text{TDD inter}}} \cdot N_{\text{Freq}} \right\} \text{ms}$$

If the UE does not need compressed mode to perform inter-frequency TDD measurements, the measurement period for inter-frequency TDD measurements shall be 480 ms.

The UE shall be capable of performing P-CCPCH RSCP measurements for $X_{\text{basic measurement TDD inter}}$ inter-frequency TDD cells per TDD frequency of the monitored set and the UE physical layer shall be capable of reporting measurements to higher layers with the measurement period of $T_{\text{measurement TDD inter}}$.

where

$$X_{\text{basic measurement TDD inter}} = 6 \text{ (cells)}$$

$T_{\text{Measurement_Period TDD inter}} = 480$ ms. The time period used for calculating the measurement period $T_{\text{measurement_TDD inter}}$ for inter frequency P-CCPCH RSCP measurements.

$N_{\text{TDD inter}}$: This is the smallest resulting integer number of transmission gap patterns in a transmission gap pattern sequence assigned to UE by UTRAN for inter frequency TDD measurements during the time period

$T_{\text{Measurement_Period TDD inter}}$ with an arbitrarily chosen timing.

$N_{\text{basic_identify_TDD inter}} = 80$. This is the number of transmission gap patterns in a transmission gap pattern sequence for inter-frequency TDD measurements during the time period used in the inter frequency TDD equation where the maximum allowed time for the UE to identify a new inter frequency TDD cell is defined.

$N_{\text{basic_measurement_TDD inter}} = 5$. This is the number of transmission gap patterns in a transmission gap pattern sequence for inter-frequency TDD measurements during the time period $T_{\text{Measurement_Period TDD inter}}$ with an arbitrarily chosen timing that is used in the inter-frequency TDD equation for defining where the measurement period for inter frequency P-CCPCH RSCP measurements is defined.

N_{Freq} : This is the number of TDD frequencies indicated in the inter frequency measurement control information.

8.6.3.1.2.2 1.28Mcps TDD option

When transmission gaps are scheduled for inter-frequency TDD measurements, the UE shall be able to identify a new detectable inter-frequency TDD cell belonging to the monitored set within

$$T_{\text{identify TDD inter}} = \text{Max} \left\{ 5000, N_{\text{basic identify TDD inter}} \cdot \frac{T_{\text{Measurement Period TDD inter}}}{N_{\text{TDD inter}}} \cdot N_{\text{Freq}} \right\} \text{ms}$$

If the UE does not need compressed mode to perform inter-frequency TDD measurements, the UE shall be able to identify a new detectable inter-frequency TDD cell belonging to the monitored set within 5000 ms.

An inter-frequency TDD cell shall be considered detectable when $P\text{-CCPCH } E_c/I_o \geq -8$ dB and $DwPCH_E_c/I_o \geq -5$ dB. When L3 filtering is used an additional delay can be expected.

When transmission gaps are scheduled for inter frequency TDD measurements the UE physical layer shall be capable of reporting measurements to higher layers with a measurement period as given by

$$T_{\text{measurement TDD inter}} = \text{Max} \left\{ T_{\text{Measurement Period TDD inter}}, N_{\text{basic measurement TDD inter}} \cdot \frac{T_{\text{Measurement Period TDD inter}}}{N_{\text{TDD inter}}} \cdot N_{\text{Freq}} \right\} \text{ms}$$

If the UE does not need compressed mode to perform inter-frequency TDD measurements, the measurement period for inter-frequency TDD measurements shall be 480 ms.

The UE shall be capable of performing P-CCPCH RSCP measurements for $X_{\text{basic measurement TDD inter}}$ inter-frequency TDD cells per TDD frequency of the monitored set and the UE physical layer shall be capable of reporting measurements to higher layers with the measurement period of $T_{\text{measurement TDD inter}}$.

where

$$X_{\text{basic measurement TDD inter}} = 6 \text{ (cells)}$$

$T_{\text{Measurement_Period TDD inter}} = 480$ ms. The time period used for calculating the measurement period $T_{\text{measurement_TDD inter}}$ for inter frequency P-CCPCH RSCP measurements.

$N_{\text{TDD inter}}$: This is the smallest resulting integer number of transmission gap patterns in a transmission gap pattern sequence assigned to UE by UTRAN for inter frequency TDD measurements during the time period $T_{\text{Measurement_Period TDD inter}}$ with an arbitrarily chosen timing.

$N_{\text{basic_identify_TDD inter}} = 80$. This is the number of transmission gap patterns in a transmission gap pattern sequence for inter-frequency TDD measurements during the time period used in the inter frequency TDD equation where the maximum allowed time for the UE to identify a new inter frequency TDD cell is defined.

$N_{\text{basic_measurement_TDD inter}} = 5$. This is the number of transmission gap patterns in a transmission gap pattern sequence for inter-frequency TDD measurements during the time period $T_{\text{Measurement_Period TDD inter}}$ with an arbitrarily chosen timing that is used in the inter-frequency TDD equation for defining where the measurement period for inter frequency P-CCPCH RSCP measurements is defined.

N_{Freq} : This is the number of TDD frequencies indicated in the inter frequency measurement control information.

The normative reference for this requirement is TS 25.133 [2] clauses 8.1.2.4 and A.8.3.1

8.6.3.1.3 Test purpose

To verify that the UE meets the minimum requirement.

8.6.3.1.4 Method of test

8.6.3.1.4.1 Initial conditions

8.6.3.1.4.1.1 3.84Mcps TDD option

Test environment: normal; see clauses G.2.1 and G.2.2.

Frequencies to be tested: mid range; see clause G.2.4.

The test parameters are given in Table 8.6.3.1.1, 8.6.3.1.2 and 8.6.3.1.3. The test consists of 2 successive time periods, with a time duration T1 and T2. Two cells shall be present in the test, cell 1 being the UTRA FDD serving cell and cell 2 being a 3.84Mcps TDD neighbour cell on the unused frequency. All cells shall be synchronised, i.e. share the same frame and timeslot timing.

In the measurement control information it is indicated to the UE that event-triggered reporting with Event 2C shall be used. P-CCPCH RSCP of the best cell on the unused frequency shall be reported together with Event 2C reporting. The Measurement control message shall be sent to the UE such that the delay between the end of the last received TTI containing the message and the beginning of T1 is at least equal to the RRC procedure delay as defined in [9].

The TTI of the uplink DCCH shall be 20 ms.

Table 8.6.3.1.1: General test parameters for Correct reporting of TDD inter-frequency neighbours in AWGN propagation condition

Parameter	Unit	Value	Comment
DCH parameters		DL Reference Measurement Channel 12.2 kbps	As specified in TS 34.121 Annex C
Power Control		On	
Target quality value on DTCH	BLER	0.01	
Compressed mode		A.22 set 3	As specified in TS 34.121 Annex C
Initial conditions	Active cell	Cell 1	FDD cell
	Neighbour cell	Cell 2	TDD cell
Final condition	Active cell	Cell 1	FDD cell
O	dB	0	Cell individual offset. This value shall be used for all cells in the test.
Hysteresis	dB	0	Hysteresis parameter for event 2C
Time to Trigger	ms	0	
Threshold non-used frequency	dBm	-71	Applicable for Event 2C
Filter coefficient		0	
Monitored cell list size		6 FDD neighbours on Channel 1 6 TDD neighbours on Channel 2	
T1	S	15	
T2	S	10	

Table 8.6.3.1.2: Cell 1 specific parameters for Correct reporting of TDD inter-frequency neighbours in AWGN propagation condition

Parameter	Unit	Cell 1
		T1, T2
UTRA RF Channel Number		Channel 1
CPICH_Ec/I _{or}	dB	-10
P-CCPCH_Ec/I _{or}	dB	-12
SCH_Ec/I _{or}	dB	-12
PICH_Ec/I _{or}	dB	-15
DPCH_Ec/I _{or}	dB	Note 1
OCNS_Ec/I _{or}	dB	Note 2
\hat{I}_{or}/I_{oc}	dB	0
I_{oc}	dBm/3.84 MHz	-70
CPICH_Ec/I _o	dB	-13
Propagation Condition		AWGN
Note 1: The DPCH level is controlled by the power control loop		
Note 2: The power of the OCNS channel that is added shall make the total power from the cell to be equal to I_{or} .		

Table 8.6.3.1.3: Cell 2 specific parameters for Correct reporting of TDD inter-frequency neighbours in AWGN propagation condition

Parameter	Unit	Cell 2			
		0		8	
DL timeslot number		T1	T2	T1	T2
UTRA RF Channel Number		Channel 2			
P-CCPCH_Ec/I _{or}	dB	-3		n.a.	
PICH_Ec/I _{or}	dB	n.a.		-3	
SCH_Ec/I _{or}	dB	-9			
SCH_t _{offset}	dB	10			
OCNS_Ec/I _{or}	dB	-3.12			
P-CCPCH RSCP	dBm	-75	-67	n.a.	n.a.
\hat{I}_{or}/I_{oc}	dB	-2	6	-2	6
I_{oc}	dBm/3,84 MHz	-70			
Propagation Condition		AWGN			
Note that the transmit energy per PN chip for the SCH is averaged over the 256 chip duration when the SCH is present in the time slot.					

8.6.3.1.4.1.2 1.28Mcps TDD option

Test environment: normal; see clauses G.2.1 and G.2.2.

Frequencies to be tested: mid range; see clause G.2.4.

The test parameters are given in Table 8.6.3.1.1A, 8.6.3.1.2A and 8.6.3.1.3A. The test consists of 2 successive time periods, with a time duration T1 and T2. Two cells shall be present in the test, cell 1 being the UTRA FDD serving cell and cell 2 being a 1.28Mcps TDD neighbour cell on the unused frequency. All cells shall be synchronised, i.e. share the same frame and timeslot timing.

In the measurement control information it is indicated to the UE that event-triggered reporting with Event 2C shall be used. P-CCPCH RSCP of the best cell on the unused frequency shall be reported together with Event 2C reporting. The Measurement control message shall be sent to the UE such that the delay between the end of the last received TTI containing the message and the beginning of T1 is at least equal to the RRC procedure delay as defined in [9].

The TTI of the uplink DCCH shall be 20 ms.

Table 8.6.3.1.1A: General test parameters for Correct reporting of TDD inter-frequency neighbours in AWGN propagation condition

Parameter	Unit	Value	Comment
DCH parameters		DL Reference Measurement Channel 12.2 kbps	As specified in TS 25.101 section A.3.1
Power Control		On	
Target quality value on DTCH	BLER	0.01	
Compressed mode		A.22 set 3	As specified in TS25.101 section A.5
Initial conditions	Active cell	Cell 1	FDD cell
	Neighbour cell	Cell 2	TDD cell
Final condition	Active cell	Cell 1	FDD cell
O	dB	0	Cell individual offset. This value shall be used for all cells in the test.
Hysteresis	dB	0	Hysteresis parameter for event 2C
Time to Trigger	ms	0	
Threshold non-used frequency	dBm	-71	Applicable for Event 2C
Filter coefficient		0	
Monitored cell list size		6 FDD neighbours on Channel 1 6 TDD neighbours on Channel 2	
T1	s	15	
T2	s	10	

Table 8.6.3.1.2A: Cell 1 specific parameters for Correct reporting of TDD inter-frequency neighbours in AWGN propagation condition

Parameter	Unit	Cell 1
		T1, T2
UTRA RF Channel Number		Channel 1
CPICH_Ec/lor	dB	-10
P-CCPCH_Ec/lor	dB	-12
SCH_Ec/lor	dB	-12
PICH_Ec/lor	dB	-15
DPCH_Ec/lor	dB	Note 1
OCNS_Ec/lor	dB	Note 2
\hat{I}_{or}/I_{oc}	dB	0
I_{oc}	dBm/3.84 MHz	-70
CPICH_Ec/lo	dB	-13
Propagation Condition		AWGN
Note 1: The DPCH level is controlled by the power control loop		
Note 2: The power of the OCNS channel that is added shall make the total power from the cell to be equal to I_{or} .		

Table 8.6.3.1.3A: Cell 2 specific parameters for Correct reporting of TDD inter-frequency neighbours in AWGN propagation condition

Parameter	Unit	Cell 2			
		0		DwPTs	
DL timeslot number		T1	T2	T1	T2
UTRA RF Channel Number		Channel 2			
P-CCPCH_Ec/lor	dB	-3			
DwPCH_Ec/lor	dB			0	
OCNS_Ec/lor	dB	-3			
P-CCPCH RSCP	dBm	-75	-67		
\hat{I}_{or}/I_{oc}	dB	-2	6	-2	6
I_{oc}	dBm/1.28 MHz	-70			
Propagation Condition		AWGN			

8.6.3.1.4.2 Procedure

- 1) The RF parameters are set up according to T1.
- 2) The UE is switched on.
- 3) A call is set up according to the generic set-up procedure specified in TS 34.108 [3] subclause 7.3.2.
- 4) SS shall transmit a MEASUREMENT CONTROL message.
- 5) SS shall transmit a PHYSICAL CHANNEL RECONFIGURATION message.
- 6) UE shall transmit a PHYSICAL CHANNEL RECONFIGURATION COMPLETE message
- 7) After 10 seconds from the beginning of T1, the SS shall switch the power settings from T1 to T2.
- 8) UE shall transmit a MEASUREMENT REPORT message triggered by event 2c for cell 2. The measurement reporting delay from the beginning of T2 shall be less than 9.2 s. If the UE fails to report the event within the required delay, then a failure is recorded. If the reporting delay for this event is within the required limit, the number of successful tests is increased by one.
- 9) After 10 seconds from the beginning of T3, the UE is switched off. Any timing information of cell 2 is deleted in the UE.

10) Repeat steps 1-9 until the confidence level according to annex F.6.2 is achieved.

Specific Message Contents

All messages indicated above shall use the same content as described in the default message content in clause 9 of 34.108 [3], with the following exceptions:

MEASUREMENT CONTROL message (step 4):

Information Element/Group name	Value/Remark
Message Type (10.2.17)	
UE information elements	
-RRC transaction identifier	0
-Integrity check info	
-message authentication code	SS calculates the value of MAC-I for this message and writes to this IE. The first/ leftmost bit of the bit string contains the most significant bit of the MAC-I.
-RRC message sequence number	SS provides the value of this IE, from its internal counter.
Measurement Information elements	
-Measurement Identity	1
-Measurement Command (10.3.7.46)	Modify
-Measurement Reporting Mode (10.3.7.49)	
-Measurement Report Transfer Mode	AM RLC
-Periodical Reporting / Event Trigger Reporting Mode	Event trigger
-Additional measurements list (10.3.7.1)	Not Present
-CHOICE <i>Measurement type</i>	Inter-frequency measurement
-Inter-frequency measurement (10.3.7.16)	
-Inter-frequency measurement objects list (10.3.7.13)	
-CHOICE <i>inter-frequency cell removal</i>	No inter-frequency cells removed
-New inter-frequency cells	1
-Inter-frequency cell id	1
-Frequency info (10.3.6.36)	
-CHOICE <i>mode</i>	TDD
-UARFCN(Nt)	Same frequency as channel 2 in Table 8.6.2.4.1.2
-Cell info (10.3.7.2)	
-Cell individual offset	Not Present
-Reference time difference to cell	Not Present
-Read SFN indicator	False
-CHOICE <i>mode</i>	TDD
-Primary CCPCH info (10.3.6.57)	
-CHOICE <i>mode</i>	TDD
-3.84Mcps	
-CHOICE <i>Sync case</i>	2
-Timeslot	0
-1.28 Mcps	
- TSTD indicator	True
-cell parameters ID	Set to cell parameters ID of cell 2
-SCTD indicator	FALSE
-Primary CCPCH Tx power	Set to Primary CCPCH Tx power of cell 2 as described in Table 8.6.2.4.1.2
-Timeslot list	Not Present
-Cell selection and re-selection info	Not Present
-Cell for measurement	Not Present
-Inter-frequency measurement quantity (10.3.7.18)	
-CHOICE <i>reporting criteria</i>	Inter-frequency reporting criteria
-Filter coefficient (10.3.7.9)	0
-CHOICE <i>mode</i>	TDD
-Measurement quantity for frequency quality estimate	Primary CCPCH RSCP
-Inter-frequency reporting quantity (10.3.7.21)	
-UTRA carrier RSSI	
-Frequency quality estimate	
-Non frequency related cell reporting quantities (10.3.7.5)	
-Cell synchronisation information reporting indicator	FALSE
-Cell identity reporting indicator	FALSE
-CHOICE <i>mode</i>	TDD
-Timeslot ISCP reporting indicator	FALSE
-Proposed TGSN Reporting required	FALSE
-Primary CCPCH RSCP reporting indicator	TRUE
-Pathloss reporting indicator	FALSE
-Reporting cell status (10.3.7.61)	Not Present
-Measurement validity (10.3.7.51)	Not Present
-CHOICE <i>report criteria</i>	Inter-frequency measurement reporting

Information Element/Group name	Value/Remark
-Inter-frequency measurement reporting criteria (10.3.7.19) -Parameters required for each event	criteria 1
-Intra-frequency event identity -Threshold used frequency -W Used frequency -Hysteresis -Time to trigger -Reporting Cell Status (10.3..61) -CHOICE reported cell -Maximum number of reported cells -Parameters required for each non-used frequenc - Threshold non-used frequency - W non-used frequency	Event 2C Not Present Not Present 0 dB 0 ms Report cells within active and/or monitored set on used frequency or within virtual active and/or monitored set on non-used frequency 3 -71 1
Physical channel information elements -DPCH compressed mode status info (10.3.6.34)	Not Present

PHYSICAL CHANNEL RECONFIGURATION message (Step 6)

Information Element	Value/Remark	Version
Message Type		
UE Information Elements		
-RRC transaction identifier	0	
-Integrity check info		
-message authentication code	SS calculates the value of MAC-I for this message and writes to this IE. The first/ leftmost bit of the bit string contains the most significant bit of the MAC-I.	
-RRC message sequence number	SS provides the value of this IE, from its internal counter.	
-Integrity protection mode info	Not Present	
-Ciphering mode info	Not Present	
-Activation time	Not Present	
-New U-RNTI	Not Present	
-New C-RNTI	Not Present	
-RRC State Indicator	CELL_DCH	
-UTRAN DRX cycle length coefficient	Not Present	
CN Information Elements		
-CN Information info	Not Present	
UTRAN mobility information elements		
-URA identity	Not Present	
RB information elements		
-Downlink counter synchronisation info	Not Present	
PhyCH information elements		
-Frequency info	Not Present	
Uplink radio resources		
-Maximum allowed UL TX power	Not Present	
Downlink radio resources		
-CHOICE mode	FDD	
-Downlink PDSCH information	Not Present	R99 and Rel-4 only
-Downlink information common for all radio links		
-Downlink DPCH info common for all RL	Not Present	
-CHOICE mode	FDD	
-DPCH compressed mode info		
-Transmission gap pattern sequence		
-TGPSI	1	
-TGPS Status Flag	Activate	
-TGCFN	(Current CFN + (256 – TTI/10msec))mod 256	
-Transmission gap pattern sequence configuration parameters		
-TGMP	TDD measurement	
-TGPRC	Not present	
-TGSCN	10	
-TGL1	10	
-TGL2	Not Present	
-TGD	UNDEFINED	
-TGPL1	11	
-TGPL2	Not Present	R99 and Rel-4 only
-RPP	Mode 0	
-ITP	Mode 0	
-CHOICE UL/DL mode	UL and DL	
-Downlink compressed mode method	SF/2	
-Uplink compressed mode method	puncturing	
-Downlink frame type	A	
-DeltaSIR1	3.0	
-DeltaSIRafter1	3.0	
-DeltaSIR2	Not Present	
-DeltaSIRafter2	Not Present	
-N Identify abort	Not Present	
-T Reconfirm abort	Not Present	
-TX Diversity Mode	Not Present	
-SSDT information	Not Present	R99 and Rel-4

-Default DPCH Offset Value	Not Present	only
-Downlink information per radio link list		
- Downlink information for each radio link		
-Choice mode	FDD	
-Primary CPICH info		
-Primary scrambling code	100	
-PDSCH with SHO DCH Info	Not Present	R99 and Rel-4 only
-PDSCH code mapping	Not Present	R99 and Rel-4 only
-Downlink DPCH info for each RL		
-CHOICE mode	FDD	
-Primary CPICH usage for channel estimation	Primary CPICH may be used	
-DPCH frame offset	Set to value Default DPCH Offset Value (as currently stored in SS) mod 38400	
-Secondary CPICH info	Not Present	
-DL channelisation code		
-Secondary scrambling code	Not Present	
-Spreading factor	128	
-Code number	96	
-Scrambling code change	No code change	
-TPC combination index	0	
-SSDT Cell Identity	Not Present	R99 and Rel-4 only
-Closed loop timing adjustment mode	Not Present	
-SCCPCH Information for FACH	Not Present	

MEASUREMENT REPORT message (step 8)

Information Element	Value/remark
Message Type (10.2.17)	
Integrity check info	
-message authentication code	SS calculates the value of MAC-I for this message and writes to this IE. The first/ leftmost bit of the bit string contains the most significant bit of the MAC-I.
-RRC message sequence number	SS provides the value of this IE, from its internal counter.
Measurement identity	1
Measured Results (10.3.7.44)	
-CHOICE Measurement	Inter-frequency Measured results list
-Inter-frequency measured results	1
-Frequency info	TDD
-CHOICE mode	Same frequency as channel 2
-UARFCN(Nt)	Not Present
-UTRA carrier RSSI	1
-Inter-frequency cell measured results	1
-Cell measured results (10.3.7.3)	
-Cell identity	Not Present
-Cell synchronisation info	Not Present
-CHOICE mode	TDD
-Cell parameters ID	Set to cell parameters ID of Cell 2
-Proposed TGSN	Not Present
-Primary CCPCH RSCP	Checked that this IE is present
-Pathloss	Not Present
-Timeslot list	Not Present
Measured results on RACH	Not Present
Additional measured results	Not Present
Event results (10.3.7.7)	
-CHOICE event result	Inter-frequency measurement event results
-Inter-frequency event identity	2C
-Inter-frequency cells	1
-Frequency Info	TDD
-CHOICE mode	Same frequency as channel 2
-UARFCN(Nt)	TDD
-CHOICE mode	TDD
-Primary CCPCH Info	TDD
-CHOICE mode	TDD
-CHOICE Sync Case	Not Present
-Cell Parameters ID	Set to cell parameters ID of Cell 2
-SCTD Indicator	FALSE

8.6.3.1.5 Test requirements

The UE shall send one Event 2C triggered measurement report for Cell 2 with a measurement reporting delay less than 9.2 s from the beginning of time period T2.

The UE shall not send event triggered measurement reports, as long as the reporting criteria are not fulfilled.

For the test to pass, the total number of successful tests shall be more than 90% of the cases with a confidence level of 95%.

8.6.4 GSM measurements

8.6.4.1 Correct reporting of GSM neighbours in AWGN propagation condition

8.6.4.1.1 Definition and applicability

In the event triggered reporting period the measurement reporting delay is defined as the time between any event that will trigger a measurement report until the UE starts to transmit the measurement report over the Uu interface. This requirement assumes that the measurement report is not delayed by other RRC signalling on the DCCH. This measurement reporting delay excludes a delay uncertainty resulted when inserting the measurement report to the TTI of the uplink DCCH. The delay uncertainty is twice the TTI of the uplink DCCH.

The requirements in this section apply only to UE supporting FDD and GSM for Release 99 and later releases.

8.6.4.1.2 Minimum requirements

Measurements on GSM cells can be requested with BSIC verified or BSIC non-verified.

- 1) In CELL_DCH state when a transmission gap pattern sequence is provided by the UTRAN the UE shall continuously measure GSM cells and search for new GSM cells given in the monitored set.
- 2) If the UE does not need compressed mode to perform GSM measurements:
 - the UE shall measure all GSM cells present in the monitored set
 - the relevant requirements for GSM dedicated mode when a TCH channel is assigned in TS 45.008 shall apply.

The normative reference for these requirements is TS 25.133 [2] clauses 8.1.2.5 and A.8.4.1.

8.6.4.1.3 Test purpose

To verify that the UE meets the minimum requirements.

8.6.4.1.4 Method of test

8.6.4.1.4.1 Test 1 initial conditions

Test 1 with BSIC verification required case:

Test environment: normal; see clauses G.2.1 and G.2.2.

Frequencies to be tested: mid range; see clause G.2.4.

The test parameters are given in table 8.6.4.1, 8.6.4.2 and 8.6.4.3 below. In the measurement control information it is indicated to the UE that event-triggered reporting with Event 3B and 3C shall be used. The test consists of three successive time periods, with a time duration of T1, T2 and T3 respectively.

Table 8.6.4.1: General test parameters for Correct reporting of GSM neighbours in AWGN propagation condition, Test 1

Parameter	Unit	Value	Comment
DCH parameters		DL Reference Measurement Channel 12.2 kbps	As specified in TS 25.101 section A.3.1
Power Control		On	
Target quality value on DTCH	BLER	0.01	
Compressed mode patterns - GSM carrier RSSI measurement - GSM Initial BSIC identification		DL Compressed mode reference pattern 2 in Set 2 Pattern 2	Only applicable for UE requiring compressed mode patterns As specified in table A.22 TS 25.101 section A.5 As specified in section 8.1.2.5.2.1 TS 25.133 [2] table 8.7.
Active cell		Cell 1	
Inter-RAT measurement quantity		GSM Carrier RSSI	
BSIC verification required		Required	
Threshold other system	dBm	-80	Absolute GSM carrier RSSI threshold for event 3B and 3C.
Hysteresis	dB	0	
Time to Trigger	ms	0	
Filter coefficient		0	
Monitored cell list size		24 FDD neighbours on Channel 1 6 GSM neighbours including the ARFCN of cell 2	See Annex I for cell information. Measurement control information is sent before the compressed mode patterns starts.
N Identify abort		66	Taken from table 8.7 in TS 25.133 [2].
T1	s	5	
T2	s	7	
T3	s	5	

Table 8.6.4.2: Cell specific test parameters for Correct reporting of GSM neighbours in AWGN propagation condition (cell 1)

Parameter	Unit	Cell 1
		T0, T1, T2, T3
UTRA RF Channel Number		Channel 1
CPICH_Ec/lor	dB	-10
PCCPCH_Ec/lor	dB	-12
SCH_Ec/lor	dB	-12
PICH_Ec/lor	dB	-15
DPCH_Ec/lor	dB	Note 1
OCNS_Ec/lor	dB	Note 2
\hat{I}_{or}/I_{oc}	dB	0
I_{oc}	dBm/ 3.84 MHz	-85
CPICH_Ec/lo	dB	-13
Propagation Condition		AWGN
Note 1: The DPCH level is controlled by the power control loop.		
Note 2: The power of the OCNS channel that is added shall make the total power from the cell to be equal to I_{or} .		

Table 8.6.4.3: Cell specific test parameters for Correct reporting of GSM neighbours in AWGN propagation condition (cell 2)

Parameter	Unit	Cell 2			
		T0	T1	T2	T3
Absolute RF Channel Number RXLEV	dBm	-Infinity	ARFCN 1	-75	-85
			-Infinity		

8.6.4.1.4.2 Test 1 Procedure

- 1) The RF parameters are set up according to T0 in Table 8.6.4.2 and 8.6.4.7.
- 2) The UE is switched on.
- 3) A call is set up according to the test procedure specified in TS 34.108 [3] sub clause 7.3.2. The RF parameters are set up according to T1 in Table 8.6.4.2 and 8.6.4.7.
- 4) SS shall transmit PHYSICAL CHANNEL RECONFIGURATION message.
- 5) UE shall transmit PHYSICAL CHANNEL RECONFIGURATION COMPLETE message6)SS shall transmit a MEASUREMENT CONTROL message.
- 7) After 5 seconds from the beginning of T1, the SS shall switch the power settings from T1 to T2 in Table 8.6.4.2 and 8.6.4.7.
- 8) UE shall transmit a MEASUREMENT REPORT message triggered by event 3C. The measurement reporting delay from the beginning of T2 shall be less than 6.32s. If the UE fails to report the event within the required delay, then the counter event3C_failure is increased by one. If the reporting delay for this event is within the required limit, the counter event3C_success is increased by one.
- 9) After 7 seconds from the beginning of T2, the SS shall switch the power settings from T2 to T3 in Table 8.6.4.2 and 8.6.4.7.
- 10) UE shall transmit a MEASUREMENT REPORT message triggered by event 3B. The measurement reporting delay from the beginning of T3 shall be less than 1040 ms. If the UE fails to report the event within the required delay, then the counter event3B_failure is increased by one. If the reporting delay for this event is within the required limit, the counter event3B_success is increased by one.
- 11) After the SS receive the MEASUREMENT REPORT message in step 10) or 5 seconds after the beginning of T3, the UE is switched off.
- 12) Repeat steps 1-11 according to Annex F.6.2 Table F.6.2.8. If one counter reaches the pass criterion, this counter is stopped and the remaining counters are continued. For the overall outcome of the test to be considered a pass, the counters for 3C events and for 3B events shall independently indicate a pass result. The test is stopped immediately and the test is considered to be a fail, if any counter reaches an early fail criterion.

Specific Message Contents

All messages indicated above shall use the same content as described in the default message content in clause 9 of 34.108 [3], with the following exceptions:

PHYSICAL CHANNEL RECONFIGURATION message for Inter Rat measurement (step 4):

Information Element	Value/Remark	Version
Message Type (10.2.22)		
UE Information Elements		
-RRC transaction identifier	0	
-Integrity check info		
-message authentication code	SS calculates the value of MAC-I for this message and writes to this IE. The first/ leftmost bit of the bit string contains the most significant bit of the MAC-I.	
-RRC message sequence number	SS provides the value of this IE, from its internal counter.	
-Integrity protection mode info	Not Present	
-Ciphering mode info	Not Present	
-Activation time	Not Present	
-New U-RNTI	Not Present	
-New C-RNTI	Not Present	
-RRC State Indicator	CELL_DCH	
-UTRAN DRX cycle length coefficient	Not Present	
CN Information Elements		
-CN Information info	Not Present	
UTRAN mobility information elements		
-URA identity	Not Present	
RB information elements		
-Downlink counter synchronisation info	Not Present	
PhyCH information elements		
-Frequency info (10.3.6.36)	Not Present	
Uplink radio resources		
-Maximum allowed UL TX power	33 dBm	
-CHOICE <i>channel requirement</i>	Not Present	
Downlink radio resources		
-CHOICE <i>mode</i>	FDD	
-Downlink PDSCH information	Not Present	R99 and Rel-4 only
-Downlink information common for all radio links (10.3.6.24)		
-Downlink DPCH info common for all RL (10.3.6.18)	Not Present	
-CHOICE <i>mode</i>	FDD	
-DPCH compressed mode info (10.3.6.33)	(1/2 TGPS)	
- Transmission gap pattern sequence		
- TGPSI	1	
- TGPS Status Flag	deactivate	
- Transmission gap pattern sequence		
configuration parameters		
-TGMP	GSM carrier RSSI measurement	
-TGPRC	Infinity	
-TGSN	4	
-TGL1	7	
-TGL2	Not Present	
-TGD	UNDEFINED	
-TGPL1	12	
-TGPL2	Not Present	R99 and Rel-4 only
-RPP	mode 0	
-ITP	mode 0	
-CHOICE UL/DL mode	UL and DL	
-Downlink compressed mode method	SF/2	
-Uplink compressed mode method	SF/2	
-Downlink frame type	B	
-DeltaSIR1	3.0	
-DeltaSIRafter1	3.0	
-DeltaSIR2	Not Present	
-DeltaSIRafter2	Not Present	
-N Identify abort	Not Present	
-T Reconfirm abort	Not Present	
- Transmission gap pattern sequence	(2/2 TGPS)	
- TGPSI	2	
- TGPS Status Flag	deactivate	

Information Element	Value/Remark	Version
- Transmission gap pattern sequence configuration parameters		
-TGMP	gsm-initialBSICIdentification	
-TGPRC	Infinity	
-TGSN	4	
-TGL1	7	
-TGL2	Not Present	
-TGD	UNDEFINED	
-TGPL1	8	
-TGPL2	Not Present	
-RPP	mode 0	
-ITP	mode 0	
-CHOICE UL/DL mode	UL and DL	
-Downlink compressed mode method	SF/2	
-Uplink compressed mode method	SF/2	
-Downlink frame type	B	
-DeltaSIR1	3.0	
-DeltaSIRafter1	3.0	
-DeltaSIR2	Not Present	
-DeltaSIRafter2	Not Present	
-N Identify abort	66	
-T Reconfirm abort	Not Present	
-SSDT information (10.3.6.77)	Not Present	R99 and Rel-4 only
-Default DPCH Offset Value (10.3.6.16)	Not Present	
-Downlink information per radio link list	1	
-Downlink information for each radio link (10.3.6.27)		
-CHOICE mode	FDD	
-Primary CPICH info (10.3.6.60)		
-Primary scrambling code	100	
-PDSCH with SHO DCH info (10.3.6.47)	Not Present	R99 and Rel-4 only
-PDSCH code mapping (10.3.6.43)	Not Present	R99 and Rel-4 only
-Downlink DPCH info for each RL (10.3.6.21)		
-CHOICE mode	FDD	
-Primary CPICH usage for channel estimation	Primary CPICH may be used	
-DPCH frame offset	Set to value Default DPCH Offset Value (as currently stored in SS) mod 38400	
-Secondary CPICH info	Not Present	
-DL channelisation code		
-Secondary scrambling code	Not Present	
-Spreading factor	128	
-Code number	96	
-Scrambling code change	No change	
-TPC combination index	0	
-SSDT Cell Identity	Not Present	R99 and Rel-4 only
- Closed loop timing adjustment mode	Not Present	
- SCCPCH information for FACH (10.3.6.70)	Not Present	

MEASUREMENT CONTROL message:

Information Element/Group name	Value/Remark
Message Type (10.2.17)	
UE information elements	
-RRC transaction identifier	0
-Integrity check info	
-message authentication code	SS calculates the value of MAC-I for this message and writes to this IE. The first/ leftmost bit of the bit string contains the most significant bit of the MAC-I.
-RRC message sequence number	SS provides the value of this IE, from its internal counter.
Measurement Information elements	
-Measurement Identity	2
-Measurement Command (10.3.7.46)	Setup
-Measurement Reporting Mode (10.3.7.49)	
-Measurement Report Transfer Mode	AM RLC
-Periodical Reporting / Event Trigger Reporting Mode	Event trigger
-Additional measurements list (10.3.7.1)	Not Present
-CHOICE <i>Measurement type</i>	Inter-RAT measurement
-Inter-RAT measurement (10.3.7.27)	
-Inter-RAT measurement objects list (10.3.7.23)	Not Present
-Inter-RAT measurement quantity (10.3.7.29)	
-Measurement quantity for UTRAN quality estimate (10.3.7.38)	
-Filter coefficient	0
-CHOICE mode	FDD
-Measurement quantity	CPICH Ec/N0
-CHOICE system	GSM
-Measurement quantity	GSM Carrier RSSI
-Filter coefficient	0
-BSIC verification required	Required
-Inter-RAT reporting quantity (10.3.7.32)	
- UTRAN estimated quality	FALSE
- CHOICE system	GSM
- Observed time difference to GSM cell reporting indicator	FALSE
- GSM Carrier RSSI reporting indicator	FALSE
-Reporting cell status (10.3.7.61)	Not Present
-CHOICE report criteria	Inter-RAT measurement reporting criteria
-Inter-RAT measurement reporting criteria (10.3.7.30)	
-Parameters required for each event	2
-Inter-RAT event identity (10.3.7.24)	Event 3B
-Threshold own system	Not Present
-W	Not Present
-Threshold other system	-80 dBm
-Hysteresis	0 dB
-Time to trigger	0 ms
-Reporting cell status (10.3.7.61)	
-CHOICE reported cell	Report cells within active set or within virtual active set or of the other RAT
-Maximum number of reported cells	2
-Inter-RAT event identity (10.3.7.24)	Event 3C
-Threshold own system	Not Present
-W	Not Present
-Threshold other system	-80 dBm
-Hysteresis	0 dB
-Time to trigger	0 ms
-Reporting cell status (10.3.7.61)	
-CHOICE reported cell	Report cells within active set or within virtual active set or of the other RAT
-Maximum number of reported cells	2
Physical channel information elements	
-DPCH compressed mode status info (10.3.6.34)	Active (for two patterns specified in table 8.6.4.1)

8.6.4.1.4.3 Test 2 initial conditions

Test 2 without BSIC verification required case:

Test environment: normal; see clauses G.2.1 and G.2.2.

Frequencies to be tested: mid range; see clause G.2.4.

The test parameters are given in table 8.6.4.4, 8.6.4.5 and 8.6.4.6 below. In the measurement control information it is indicated to the UE that event-triggered reporting with Event 3B and 3C shall be used. The test consists of three successive time periods, with a time duration of T1, T2 and T3 respectively.

Table 8.6.4.4: General test parameters for Correct reporting of GSM neighbours in AWGN propagation condition, Test 2

Parameter	Unit	Value	Comment
DCH parameters		DL Reference Measurement Channel 12.2 kbps	As specified in TS 25.101 section A.3.1
Power Control		On	
Target quality value on DTCH	BLER	0.01	
Compressed mode patterns - GSM carrier RSSI measurement		DL Compressed mode reference pattern 2 in Set 2	Only applicable for UE requiring compressed mode patterns As specified in table A.22 TS 25.101 section A.5
Active cell		Cell 1	
Inter-RAT measurement quantity		GSM Carrier RSSI	
BSIC verification required		not required	
Threshold other system	dBm	-80	Absolute GSM carrier RSSI threshold for event 3B and 3C.
Hysteresis	dB	0	
Time to Trigger	Ms	0	
Filter coefficient		0	
Monitored cell list size		24 FDD neighbours on Channel 1 6 GSM neighbours including the ARFCN of cell 2	See Annex I for cell information. Measurement control information is sent before the compressed mode patterns starts.
T1	s	5	
T2	s	2	
T3	s	5	

Table 8.6.4.5: Cell specific test parameters for Correct reporting of GSM neighbours in AWGN propagation condition (cell 1)

Parameter	Unit	Cell 1
		T0, T1, T2, T3
UTRA RF Channel Number		Channel 1
CPICH_Ec/lor	dB	-10
PCCPCH_Ec/lor	dB	-12
SCH_Ec/lor	dB	-12
PICH_Ec/lor	dB	-15
DPCH_Ec/lor	dB	Note 1
OCNS_Ec/lor	dB	Note 2
\hat{I}_{or}/I_{oc}	dB	0
I_{oc}	dBm/ 3.84 MHz	-85
CPICH_Ec/lo	dB	-13
Propagation Condition		AWGN
Note 1: The DPCH level is controlled by the power control loop.		
Note 2: The power of the OCNS channel that is added shall make the total power from the cell to be equal to I_{or} .		

Table 8.6.4.6: Cell specific test parameters for Correct reporting of GSM neighbours in AWGN propagation condition (cell 2)

Parameter	Unit	Cell 2			
		T0	T1	T2	T3
Absolute RF Channel Number		ARFCN 1			
RXLEV	dBm	-Infinity	-Infinity	-75	-85

8.6.4.1.4.4 Test 2 Procedure

- 1) The RF parameters are set up according to T0 in Table 8.6.4.5 and 8.6.4.8.
- 2) The UE is switched on.
- 3) A call is set up according to the test procedure specified in TS 34.108 [3] sub clause 7.3.2. The RF parameters are set up according to T1 in Table 8.6.4.5 and 8.6.4.8.
- 4) SS shall transmit PHYSICAL CHANNEL RECONFIGURATION message.
- 5) UE shall transmit PHYSICAL CHANNEL RECONFIGURATION COMPLETE message
- 6) SS shall transmit a MEASUREMENT CONTROL message.
- 7) After 5 seconds from the beginning of T1, the SS shall switch the power settings from T1 to T2 in Table 8.6.4.5 and 8.6.4.8.
- 8) UE shall transmit a MEASUREMENT REPORT message triggered by event 3C. The measurement reporting delay from the beginning of T2 shall be less than 1040 ms. If the UE fails to report the event within the required delay, then the counter event3C_failure is increased by one. If the reporting delay for this event is within the required limit, the counter event3C_success is increased by one.
- 9) After 2 seconds from the beginning of T2, the SS shall switch the power settings from T2 to T3 in Table 8.6.4.5 and 8.6.4.8.
- 10) UE shall transmit a MEASUREMENT REPORT message triggered by event 3B. The measurement reporting delay from the beginning of T3 shall be less than 1040 ms. If the UE fails to report the event within the required delay, then the counter event3B_failure is increased by one. If the reporting delay for this event is within the required limit, the counter event3B_success is increased by one.
- 11) After the SS receive the MEASUREMENT REPORT message in step 10) or 5 seconds after the beginning of T3, the UE is switched off.
- 12) Repeat steps 1-11 according to Annex F.6.2 Table F.6.2.8. If one counter reaches the pass criterion, this counter is stopped and the remaining counters are continued. For the overall outcome of the test to be considered a pass, the counters for 3C events and for 3B events shall independently indicate a pass result. The test is stopped immediately and the test is considered to be a fail, if any counter reaches an early fail criterion.

Specific Message Contents

All messages indicated above shall use the same content as described in the default message content in clause 9 of 34.108 [3], with the following exceptions:

PHYSICAL CHANNEL RECONFIGURATION message for Inter Rat measurement (step 4):

Information Element	Value/Remark	Version
Message Type (10.2.22)		
UE Information Elements		
-RRC transaction identifier	0	
-Integrity check info		
-message authentication code	SS calculates the value of MAC-I for this message and writes to this IE. The first/ leftmost bit of the bit string contains the most significant bit of the MAC-I.	
-RRC message sequence number	SS provides the value of this IE, from its internal counter.	
-Integrity protection mode info	Not Present	
-Ciphering mode info	Not Present	
-Activation time	Not Present	
-New U-RNTI	Not Present	
-New C-RNTI	Not Present	
-RRC State Indicator	CELL_DCH	
-UTRAN DRX cycle length coefficient	Not Present	
CN Information Elements		
-CN Information info	Not Present	
UTRAN mobility information elements		
-URA identity	Not Present	
RB information elements		
-Downlink counter synchronisation info	Not Present	
PhyCH information elements		
-Frequency info (10.3.6.36)	Not Present	
Uplink radio resources		
-Maximum allowed UL TX power	33 dBm	
-CHOICE <i>channel requirement</i>	Not Present	
Downlink radio resources		
-CHOICE <i>mode</i>	FDD	
-Downlink PDSCH information	Not Present	R99 and Rel-4 only
-Downlink information common for all radio links (10.3.6.24)		
-Downlink DPCH info common for all RL (10.3.6.18)	Not Present	
-CHOICE <i>mode</i>	FDD	
-DPCH compressed mode info (10.3.6.33)		
- Transmission gap pattern sequence	1	
- TGPSI	1	
- TGPS Status Flag	deactivate	
- Transmission gap pattern sequence		
configuration parameters		
-TGMP	GSM carrier RSSI measurement	
-TGPRC	Infinity	
-TGSN	4	
-TGL1	7	
-TGL2	Not Present	
-TGD	UNDEFINED	
-TGPL1	12	
-TGPL2	Not Present	R99 and Rel-4 only
-RPP	mode 0	
-ITP	mode 0	
-CHOICE UL/DL mode	UL and DL	
-Downlink compressed mode method	SF/2	
-Uplink compressed mode method	SF/2	
-Downlink frame type	B	
-DeltaSIR1	3.0	
-DeltaSIRafter1	3.0	
-DeltaSIR2	Not Present	
-DeltaSIRafter2	Not Present	
-N Identify abort	Not Present	
-T Reconfirm abort	Not Present	
-TX Diversity mode (10.3.6.86)	None	
-SSDT information (10.3.6.77)	Not Present	R99 and Rel-4 only
-Default DPCH Offset Value (10.3.6.16)	Not Present	

Information Element	Value/Remark	Version
-Downlink information per radio link list	1	
-Downlink information for each radio link (10.3.6.27)		
-CHOICE mode	FDD	
-Primary CPICH info (10.3.6.60)		
-Primary scrambling code	100	
-PDSCH with SHO DCH info (10.3.6.47)	Not Present	R99 and Rel-4 only
-PDSCH code mapping (10.3.6.43)	Not Present	R99 and Rel-4 only
-Downlink DPCH info for each RL (10.3.6.21)		
-CHOICE mode	FDD	
-Primary CPICH usage for channel estimation	Primary CPICH may be used	
-DPCH frame offset	Set to value Default DPCH Offset Value (as currently stored in SS) mod 38400	
-Secondary CPICH info	Not Present	
-DL channelisation code		
-Secondary scrambling code	Not Present	
-Spreading factor	128	
-Code number	96	
-Scrambling code change	No change	
-TPC combination index	0	
-SSDT Cell Identity	Not Present	R99 and Rel-4 only
- Closed loop timing adjustment mode	Not Present	
- SCCPCH information for FACH (10.3.6.70)	Not Present	

MEASUREMENT CONTROL message:

Information Element/Group name	Value/Remark
Message Type (10.2.17)	
UE information elements	
-RRC transaction identifier	0
-Integrity check info	
-message authentication code	SS calculates the value of MAC-I for this message and writes to this IE. The first/ leftmost bit of the bit string contains the most significant bit of the MAC-I.
-RRC message sequence number	SS provides the value of this IE, from its internal counter.
Measurement Information elements	
-Measurement Identity	2
-Measurement Command (10.3.7.46)	Setup
-Measurement Reporting Mode (10.3.7.49)	
-Measurement Report Transfer Mode	AM RLC
-Periodical Reporting / Event Trigger Reporting Mode	Event trigger
-Additional measurements list (10.3.7.1)	Not Present
-CHOICE <i>Measurement type</i>	Inter-RAT measurement
-Inter-RAT measurement (10.3.7.27)	
-Inter-RAT measurement objects list (10.3.7.23)	Not Present
-Inter-RAT measurement quantity (10.3.7.29)	
-Measurement quantity for UTRAN quality estimate (10.3.7.38)	
-Filter coefficient	0
-CHOICE mode	FDD
-Measurement quantity	CPICH Ec/N0
-CHOICE system	GSM
-Measurement quantity	GSM Carrier RSSI
-Filter coefficient	0
-BSIC verification required	Not Required
-Inter-RAT reporting quantity (10.3.7.32)	
- UTRAN estimated quality	FALSE
- CHOICE system	GSM
- Observed time difference to GSM cell reporting indicator	FALSE
- GSM Carrier RSSI reporting indicator	FALSE
-Reporting cell status (10.3.7.61)	Not Present
-CHOICE report criteria	Inter-RAT measurement reporting criteria
-Inter-RAT measurement reporting criteria (10.3.7.30)	
-Parameters required for each event	2
-Inter-RAT event identity (10.3.7.24)	Event 3B
-Threshold own system	Not Present
-W	Not Present
-Threshold other system	-80 dBm
-Hysteresis	0 dB
-Time to trigger	0 ms
-Reporting cell status (10.3.7.61)	
-CHOICE reported cell	Report cells within active set or within virtual active set or of the other RAT
-Maximum number of reported cells	2
-Inter-RAT event identity (10.3.7.24)	Event 3C
-Threshold own system	Not Present
-W	Not Present
-Threshold other system	-80 dBm
-Hysteresis	0 dB
-Time to trigger	0 ms
-Reporting cell status (10.3.7.61)	
-CHOICE reported cell	Report cells within active set or within virtual active set or of the other RAT
-Maximum number of reported cells	2
Physical channel information elements	
-DPCH compressed mode status info (10.3.6.34)	Active (for the pattern specified in table 8.6.4.4)

MEASUREMENT REPORT message for inter – RAT test cases

These messages are common for all inter-RAT test cases and are described in Annex I.

8.6.4.1.5 Test requirements

8.6.4.1.5.1 TEST 1 With BSIC verification required

Table 8.6.4.7: Cell specific test parameters for Correct reporting of GSM neighbours in AWGN propagation condition (cell 2), test requirements

Parameter	Unit	Cell 2			
		T0	T1	T2	T3
Absolute RF Channel Number		BCCH ARFCN of cell A as defined in the initial conditions in clause 26.6.5.1 of TS 51.010-1 [25] for the GSM band under test.			
RXLEV	dBm	-Infinity	-Infinity	-75	-85

For the test to pass, the total number of successful tests shall be at least 90% of the cases, with a confidence level of 95%. For the overall outcome of the test to be considered a pass, the counters for 3C events and for 3B events shall independently indicate a pass result.

NOTE: If the above Test Requirement differs from the Minimum Requirement then the Test Tolerance applied for this test is non-zero. The Test Tolerance for this test is defined in clause F.2 and the explanation of how the Minimum Requirement has been relaxed by the Test Tolerance is given in clause F.4.

8.6.4.1.5.2 TEST 2 Without BSIC verification required

Table 8.6.4.8: Cell specific test parameters for Correct reporting of GSM neighbours in AWGN propagation condition (cell 2), test requirements

Parameter	Unit	Cell 2			
		T0	T1	T2	T3
Absolute RF Channel Number		BCCH ARFCN of cell A as defined in the initial conditions in clause 26.6.5.1 of TS 51.010-1 [25] for the GSM band under test.			
RXLEV	dBm	-Infinity	-Infinity	-75	-85

For the test to pass, the total number of successful tests shall be at least 90% of the cases, with a confidence level of 95%. For the overall outcome of the test to be considered a pass, the counters for 3C events and for 3B events shall independently indicate a pass result.

NOTE: If the above Test Requirement differs from the Minimum Requirement then the Test Tolerance applied for this test is non-zero. The Test Tolerance for this test is defined in clause F.2 and the explanation of how the Minimum Requirement has been relaxed by the Test Tolerance is given in clause F.4.

8.6.5 Combined Interfrequency and GSM measurements

8.6.5.1 Correct reporting of neighbours in AWGN propagation condition

8.6.5.1.1 Definition and applicability

In the event triggered reporting period the measurement reporting delay is defined as the time between any event that will trigger a measurement report until the UE starts to transmit the measurement report over the Uu interface. This requirement assumes that the measurement report is not delayed by other RRC signalling on the DCCH. This measurement reporting delay excludes a delay uncertainty resulted when inserting the measurement report to the TTI of the uplink DCCH. The delay uncertainty is twice the TTI of the uplink DCCH.

The requirements in this section apply only to UE supporting FDD and GSM for Release 6 and later releases.

8.6.5.1.2 Minimum requirement

When transmission gaps are scheduled for FDD inter frequency measurements the UE shall be able to identify a new detectable cell belonging to the monitored set within

$$T_{\text{identify_inter}} = \text{Max} \left\{ 5000, T_{\text{basic_identify_FDD,inter}} \cdot \frac{T_{\text{Measurement_Period, Inter}}}{T_{\text{Inter}}} \cdot N_{\text{Freq}} \right\} \text{ms}$$

The UE physical layer shall when transmission gaps are scheduled for FDD inter frequency measurements also be capable of reporting measurements to higher layers with measurement accuracy as specified in sub-clause 9.1.1 and 9.1.2 of 25.133 [2] with measurement period given by

$$T_{\text{measurement_inter}} = \text{Max} \left\{ T_{\text{Measurement_Period Inter}}, T_{\text{basic_measurement FDD inter}} \cdot \frac{T_{\text{Measurement_Period Inter}}}{T_{\text{Inter}}} \cdot N_{\text{Freq}} \right\} \text{ms}$$

If the UE does not need compressed mode to perform inter-frequency measurements, the measurement period for inter frequency measurements is 480 ms.

A cell shall be considered detectable when CPICH Ec/Io \geq -20 dB, SCH_Ec/Io \geq -17 dB for at least one channel tap and SCH_Ec/Ior is equally divided between primary synchronisation code and secondary synchronisation code. When L3 filtering is used an additional delay can be expected.

The event triggered measurement reporting delay, measured without L3 filtering shall be less than $T_{\text{identify_inter}}$ defined in Clause 8.1.2.3.1 of 25.133 [2] When L3 filtering is used an additional delay can be expected.

If a cell has been detectable at least for the time period $T_{\text{identify_inter}}$ and then enters or leaves the reporting range, the event triggered measurement reporting delay shall be less than $T_{\text{Measurement_Period Inter}}$ provided the timing to that cell has not changed more than +/-32 chips while transmission gap has not been available and the L3 filter has not been used.

Measurements on GSM cells can be requested with BSIC verified or BSIC non-verified.

- 1) In CELL_DCH state when a transmission gap pattern sequence is provided by the UTRAN the UE shall continuously measure GSM cells and search for new GSM cells given in the monitored set.
- 2) If the UE does not need compressed mode to perform GSM measurements:
 - the UE shall measure all GSM cells present in the monitored set
 - the relevant requirements for GSM dedicated mode when a TCH channel is assigned in TS 45.008 shall apply.

The normative reference for these requirements is TS 25.133 [2] clauses 8.1.2.3, 8.1.2.5 and A.8.54.1.

8.6.5.1.3 Test purpose

To verify that the UE makes correct reporting of an event when doing combined inter frequency and GSM measurements.

8.6.5.1.4 Method of test

8.6.5.1.4.1 Initial conditions

Test environment: normal; see clauses G.2.1 and G.2.2.

Frequencies to be tested: mid range; see clause G.2.4.

The test parameters are given in tables 8.6.5.1.4.1, 8.6.5.1.4.2 and 8.6.5.1.4.3. In the measurement control information it is indicated to the UE that event-triggered reporting with Event 2B and 3A shall be used as well as periodic reporting with period 4s. The test consists of five successive time periods, with a time duration T1, T2, T3, T4 and T5 respectively.

Table 8.6.5.1.4.1: General test parameters for Correct reporting of neighbours in AWGN propagation condition

Parameter	Unit	Value	Comment
DCH parameters		DL Reference Measurement Channel 12.2 kbps	As specified in C.3.1
Power Control		On	
Compressed mode			Only applicable for UE requiring compressed mode patterns.
Interfrequency measurements		DL compressed mode reference pattern 3, set 1	As specified in table C.5.3
- GSM carrier RSSI measurement		DL compressed mode reference pattern 3, set 2	As specified in table C.5.3
- GSM Initial BSIC identification		DL compressed mode reference pattern 3, set 3	As specified in table C.5.3
- GSM BSIC reconfirmation		DL compressed mode reference pattern 3, set 4	As specified in table C.5.3
Active cell		Cell 1	
Inter-RAT measurement quantity		GSM Carrier RSSI	
BSIC verification required		required	
Absolute Threshold (Ec/No) used frequency	dB	-15	Ec/lo threshold for Event 2B and 3A
Absolute Threshold (Ec/No) used for a not used frequency	dB	-15	Ec/lo threshold for Event 2B
Threshold other system	dBm	-80	Absolute GSM carrier RSSI threshold for event 3A.
Time to Trigger	ms	0	
Filter coefficient		0	
Monitored cell list size		Total 24 FDD neighbours 8 on frequency Channel 2 6 GSM neighbours including ARFCN 1	See annex I for cell information. Measurement control information is sent before the compressed mode pattern starts.
Propagation Condition		AWGN	
T1	s	1	
T2	s	4	
T3	s	1	
T4	s	8	

Table 8.6.5.1.4.2: Cell Specific parameters for Correct reporting of neighbours in AWGN propagation condition

Parameter	Unit	Cell 1					Cell 2						
		T0	T1	T2	T3	T4	T5	T0	T1	T2	T3	T4	T5
UTRA RF Channel Number		Channel 1					Channel 2						
CPICH_Ec/lor	dB	-10								-10			
PCCPCH_Ec/lor	dB	-12								-12			
SCH_Ec/lor	dB	-12								-12			
PICH_Ec/lor	dB	-15								-15			
DPCH_Ec/lor	dB	Note 1			N/A		N/A			Note 1			
OCNS		Note 2			- 0.941		-0.941			Note 2			
\hat{I}_{or} / I_{oc}	dB	0			-8		-Infinity		0	0		-8	
I_{oc}	dBm/3.84 MHz	-60											
CPICH_Ec/lo	dB	-13			-18.6		-Infinity		-13	-13	-18.6		
Note 1: The DPCH level is controlled by the power control loop Note 2: The power of the OCNS channel that is added shall make the total power from the cell to be equal to I_{or}													

Table 8.6.5.1.4.3: Cell specific test parameters for Correct reporting of GSM neighbours in AWGN propagation condition (cell 3)

Parameter	Unit	Cell 3					
		T0	T1	T2	T3	T4	T5
Absolute RF Channel Number		ARFCN 1					
RXLEV	dBm	-Infinity			-75		
GSM BSIC		N/A			Valid	Not valid	

8.6.5.1.4.2 Procedure

- 1) The RF parameters are set up according to T0 in Table 8.6.5.1.4.4 and 8.6.5.1.4.5.
- 2) The UE is switched on.
- 3) A call is set up according to the test procedure specified in TS 34.108 [3] sub clause 7.3.2.
- 4) SS shall transmit PHYSICAL CHANNEL RECONFIGURATION message (compressed gaps).
- 5) UE shall transmit PHYSICAL CHANNEL RECONFIGURATION COMPLETE message (compressed gaps).
- 6) SS shall transmit a MEASUREMENT CONTROL message (inter frequency)
- 7) SS shall transmit a MEASUREMENT CONTROL message (periodic inter RAT)
- 8) SS shall transmit a MEASUREMENT CONTROL message (event triggered inter RAT, activation of TGPSI 1-4)
- 9) 3 seconds after step8 has completed, the SS shall switch the power settings from T0 to T1 according to the parameters defined in table 8.6.5.1.4.4 and 8.6.5.1.4.5.
- 10) 1 seconds after step9 has completed, the SS shall switch the power settings from T1 to T2 according to the parameters defined in tables 8.6.5.1.4.4 and 8.6.5.1.4.5.
- 11) UE shall transmit a MEASUREMENT REPORT message (inter frequency) triggered by event 2B for cell 2. The measurement reporting delay from the beginning of T2 shall be less than 3.5 seconds. If the UE fails to report the event within the required delay, then the counter event2B_failure is increased by one. If the reporting delay for this event is within the required limit, the counter event2B_success is increased by one.
- 12) After 4 seconds from the beginning of T2, the SS shall switch the power settings from T2 to T3 according to the parameters defined in tables 8.6.5.1.4.4 and 8.6.5.1.4.5
- 13) The UE shall receive a PHYSICAL CHANNEL RECONFIGURATION so that a timing maintained hard handover is completed to cell 2 within 1 s since the beginning of T3.
- 14) UE shall transmit PHYSICAL CHANNEL RECONFIGURATION COMPLETE message
- 15) SS shall transmit a MEASUREMENT CONTROL message (Intra Frequency)
- 16) After 1 seconds from the beginning of T3, the SS shall switch the power settings from T3 to T4 according to the parameters defined in tables 8.6.5.1.4.4 and 8.6.5.1.4.5.
- 17) UE shall transmit a MEASUREMENT REPORT message (inter RAT) triggered by event 3A for cell 3. The measurement reporting delay from the beginning of T4 shall be less than 6 s. If the UE fails to report the event within the required delay, then the counter event3A_failure is increased by one. If the reporting delay for this event is within the required limit, the counter event3A_success is increased by one..
- 18) After 8 seconds from the beginning of T4, the SS shall switch the power settings from T4 to T5 according to the parameters defined in tables 8.6.5.1.4.4 and 8.6.5.1.4.5.
- 19) UE shall in a periodic MEASUREMENT REPORT message (inter RAT) indicate that the BSIC of the GSM carrier is not verified. The measurement reporting delay from the beginning of T5 until this message shall be less than 9.04 s. If the UE fails to report the event within the required delay, then the counter BSIC_failure is increased by one. If the reporting delay for this event is within the required limit, the counter BSIC_success is increased by one.

20) After the SS receive the MEASUREMENT REPORT message in step 19) or 15 seconds after the beginning of T5, the UE is switched off.

21) Repeat steps 1-19 according to Annex F.6.2 Table F.6.2.8. If one counter reaches the pass criterion, this counter is stopped and the remaining counters are continued. For the overall outcome of the test to be considered a pass, the counters for 2B events, 3A events and for BSIC events shall independently indicate a pass result. The test is stopped immediately and the test is considered to be a fail, if any counter reaches an early fail criterion.

Specific Message Contents

All messages indicated above shall use the same content as described in the default message content in clause 9 of 34.108 [3], with the following exceptions:

MEASUREMENT CONTROL message (inter frequency)

Information Element/Group name	Value/Remark
Message Type (10.2.17)	
UE information elements -RRC transaction identifier -Integrity check info -message authentication code -RRC message sequence number	0 SS calculates the value of MAC-I for this message and writes to this IE. The first/ leftmost bit of the bit string contains the most significant bit of the MAC-I. SS provides the value of this IE, from its internal counter.
Measurement Information elements -Measurement Identity -Measurement Command (10.3.7.46) -Measurement Reporting Mode (10.3.7.49) -Measurement Report Transfer Mode -Periodical Reporting / Event Trigger Reporting Mode -Additional measurements list (10.3.7.1)	1 Setup AM RLC Event trigger Not Present
-CHOICE <i>Measurement type</i> -Inter-frequency measurement (10.3.7.16) -Inter-frequency measurement objects list (10.3.7.13) - CHOICE Inter-frequency cell removal - New Inter frequency cells - Inter frequency cell id - Frequency info - CHOICE mode - UARFCN uplink(Nu) - UARFCN downlink(Nd) - Cell info - Cell individual offset - Reference time difference to cell - Read SFN indicator - CHOICE mode - Primary CPICH info - Primary scrambling code - Primary CPICH Tx Power - Tx Diversity Indicator - Cell for measurement -Inter-frequency measurement quantity (10.3.7.18) -CHOICE reporting criteria -Inter-frequency reporting criteria -Filter coefficient -CHOICE mode -Measurement quantity for frequency quality estimate	Inter-frequency measurement Not Present Refer to table K.1 FDD Not Present Same frequency as "Channel2" in Table 8.6.5.1.4.2 Not Present Not Present FALSE FDD Set to Primary scrambling code of Cell2 Not present FALSE Not Present Inter-frequency reporting criteria 0 FDD CPICH Ec/N0
-Inter-frequency reporting quantity (10.3.7.21) -UTRA Carrier RSSI -Frequency quality estimate -Non frequency related cell reporting quantities (10.3.7.5) -Cell synchronisation information reporting indicator -Cell Identity reporting indicator -CHOICE mode -CPICH Ec/N0 reporting indicator -CPICH RSCP reporting indicator -Pathloss reporting indicator	FALSE FALSE FALSE FALSE FDD TRUE FALSE FALSE
-Reporting cell status (10.3.7.61) -Measurement validity (10.3.7.51) -Inter-frequency set update (10.3.7.22) -UE autonomous update mode	Not Present Not Present On with no reporting
-CHOICE report criteria	Inter-frequency measurement reporting criteria
-Inter-frequency measurement reporting criteria (10.3.7.19) - Parameters required for each events - Inter-frequency event identity - Threshold used frequency - W used frequency	2b -15 dB 0

Information Element/Group name	Value/Remark
- Hysteresis - Time to trigger - Reporting cell status - Maximum number of reporting cells - Non used frequency parameter list - Threshold non used frequency - W non-used frequency	0 dB 0 ms Within active set or within virtual active set or of the other RAT 1 -15 dB 0
Physical channel information elements -DPCH compressed mode status info (10.3.6.34)	Not present

MEASUREMENT CONTROL message (event triggered inter RAT, activation of TGPSI 1-4)

Information Element/Group name	Value/Remark
Message Type (10.2.17)	
UE information elements	
-RRC transaction identifier	0
-Integrity check info	
-message authentication code	SS calculates the value of MAC-I for this message and writes to this IE. The first/ leftmost bit of the bit string contains the most significant bit of the MAC-I.
-RRC message sequence number	SS provides the value of this IE, from its internal counter.
Measurement Information elements	
-Measurement Identity	2
-Measurement Command (10.3.7.46)	Setup
-Measurement Reporting Mode (10.3.7.49)	
-Measurement Report Transfer Mode	AM RLC
-Periodical Reporting / Event Trigger Reporting Mode	Event trigger
-Additional measurements list (10.3.7.1)	Not Present
-CHOICE <i>Measurement type</i>	Inter-RAT measurement
-Inter-RAT measurement (10.3.7.27)	
-Inter-RAT measurement objects list (10.3.7.23)	Not Present
-Inter-RAT measurement quantity (10.3.7.29)	
-Measurement quantity for UTRAN quality estimate (10.3.7.38)	
-Filter coefficient	0
-CHOICE mode	FDD
-Measurement quantity	CPICH EcNo
-CHOICE system	GSM
-Measurement quantity	GSM Carrier RSSI
-Filter coefficient	0
-BSIC verification required	Required
-Inter-RAT reporting quantity (10.3.7.32)	
- UTRAN estimated quality	FALSE
- CHOICE system	GSM
- Observed time difference to GSM cell reporting indicator	FALSE
- GSM Carrier RSSI reporting indicator	TRUE
-Reporting cell status (10.3.7.61)	Not Present
-CHOICE report criteria	Inter-RAT measurement reporting criteria
-Inter-RAT measurement reporting criteria (10.3.7.30)	
-Inter-RAT event identity (10.3.7.24)	Event 3A
-Threshold own system	-15
-W	0
-Threshold other system	-80
-Hysteresis	0 dB
-Time to trigger	0 ms
-Reporting cell status (10.3.7.61)	
-CHOICE reported cell	Report cells within active set or within virtual active set or of the other RAT
-Maximum number of reported cells	2
Physical channel information elements	
-DPCH compressed mode status info (10.3.6.34)	
- TGPS reconfiguration CFN	(Current CFN + (230 – TTI/10msec))mod 256
-Transmission gap pattern sequence (1 to <MaxTGPS>)	
- TGPSI	1
- TGPS Status Flag	activate
- TGCFN	(TGPS reconfiguration CFN +6)mod 256
- TGPSI	2
- TGPS Status Flag	activate
- TGCFN	(TGPS reconfiguration CFN +10)mod 256
- TGPSI	3
- TGPS Status Flag	activate
- TGCFN	(TGPS reconfiguration CFN +18)mod 256
- TGPSI	4
- TGPS Status Flag	activate
- TGCFN	(TGPS reconfiguration CFN +26)mod 256

MEASUREMENT CONTROL message (periodic inter RAT)

Information Element/Group name	Value/Remark	Version
Message Type (10.2.17)		
UE information elements		
-RRC transaction identifier	0	
-Integrity check info		
-message authentication code	SS calculates the value of MAC-I for this message and writes to this IE. The first/ leftmost bit of the bit string contains the most significant bit of the MAC-I.	
-RRC message sequence number	SS provides the value of this IE, from its internal counter.	
Measurement Information elements		
-Measurement Identity	3	
-Measurement Command (10.3.7.46)	Setup	
-Measurement Reporting Mode (10.3.7.49)	AM RLC	
-Measurement Report Transfer Mode	Periodical reporting	
-Periodical Reporting / Event Trigger Reporting Mode		
-Additional measurements list (10.3.7.1)	Not Present	
-CHOICE <i>Measurement type</i>	Inter-RAT measurement	
-Inter-RAT measurement (10.3.7.27)		
-Inter-RAT measurement objects list (10.3.7.23)	Not Present	
-Inter-RAT measurement quantity (10.3.7.29)		
-Measurement quantity for UTRAN quality estimate (10.3.7.38)	Not Present	
-CHOICE system	GSM	
-Measurement quantity	GSM Carrier RSSI	
-Filter coefficient	0	
-BSIC verification required	not required	
-Inter-RAT reporting quantity (10.3.7.32)		
-UTRAN estimated quality	FALSE	
-CHOICE system	GSM	
-GSM carrier RSSI reporting indicator	TRUE	
-Reporting cell status (10.3.7.61)		
-CHOICE reported cell	Report cells within active set or within virtual active set or of the other RAT	
-Maximum number of reported cells	6	
-CHOICE report criteria	Periodical reporting criteria	
-Periodical reporting criteria (10.3.7.53)		
-Amount of reporting	Infinity	
-Reporting interval	4000 ms	
Physical channel information elements		
-DPCH compressed mode status info (10.3.6.34)	Not Present	

MEASUREMENT CONTROL message (Intra Frequency)

Information Element/Group name	Value/Remark
Message Type (10.2.17)	
UE information elements -RRC transaction identifier -Integrity check info -message authentication code -RRC message sequence number	0 SS calculates the value of MAC-I for this message and writes to this IE. The first/ leftmost bit of the bit string contains the most significant bit of the MAC-I. SS provides the value of this IE, from its internal counter.
Measurement Information elements -Measurement Identity -Measurement Command (10.3.7.46) -Measurement Reporting Mode (10.3.7.49) -Measurement Report Transfer Mode -Periodical Reporting / Event Trigger Reporting Mode -Additional measurements list (10.3.7.1)	1 Setup AM RLC Event trigger Not Present
-CHOICE <i>Measurement type</i> -Intra-frequency measurement (10.3.7.36) -Intra-frequency measurement objects list (10.3.7.33) - CHOICE Intra-frequency cell removal - New intra-frequency cells - Intra-frequency cell id - Cell info - Cell individual offset - Reference time difference to cell - Read SFN indicator - CHOICE mode - Primary CPICH info - Primary scrambling code - Primary CPICH Tx Power - Tx Diversity Indicator - Cells for measurement -Intra-frequency measurement quantity (10.3.7.38) -Filter coefficient (10.3.7.9) -CHOICE mode -Measurement quantity -Intra-frequency reporting quantity (10.3.7.41)	Intra-frequency measurement Not Present Refer to table K.1 Not Present Not Present FALSE FDD Set to Primary scrambling code of Cell2 Not present FALSE Not Present 0 FDD CPICH_Ec/N0
-Reporting quantities for active set cells (10.3.7.5) -Cell synchronisation information reporting indicator -Cell Identity reporting indicator -CHOICE mode -CPICH Ec/N0 reporting indicator -CPICH RSCP reporting indicator -Pathloss reporting indicator	FALSE TRUE FDD TRUE TRUE FALSE
-Reporting quantities for monitored set cells (10.3.7.5) -Cell synchronisation information reporting indicator -Cell Identity reporting indicator -CHOICE mode -CPICH Ec/N0 reporting indicator -CPICH RSCP reporting indicator -Pathloss reporting indicator	FALSE TRUE FDD TRUE TRUE FALSE
-Reporting quantities for detected set cells (10.3.7.5)	Not Present
-Reporting cell status (10.3.7.61) -Measurement validity (10.3.7.51) -CHOICE report criteria -Intra-frequency measurement reporting criteria (10.3.7.39) -Parameters required for each event	Not Present Not Present Intra-frequency measurement reporting criteria 1
-Intra-frequency event identity -Triggering condition 2 -Reporting Range Constant -Cells forbidden to affect Reporting Range -W -Hysteresis	Event 1A Monitored set cells 3 dB Not Present 1.0 0 dB

Information Element/Group name	Value/Remark
-Threshold used frequency -Reporting deactivation threshold -Replacement activation threshold -Time to trigger -Amount of reporting -Reporting interval -Reporting cell status (10.3.7.61) -CHOICE reported cell -Maximum number of reported cells	Not Present 0 Not Present 0 ms Infinity 0 ms (Note 1) Report cells within active set and/or monitored set cells on used frequency 2
Physical channel information elements	
-DPCH compressed mode status info (10.3.6.34)	Not Present
Note 1: Reporting interval = 0 ms means no periodical reporting	

PHYSICAL CHANNEL RECONFIGURATION (compressed gaps):

Information Element	Value/Remark	Version
Message Type (10.2.22)		
UE Information Elements		
-RRC transaction identifier	0	
-Integrity check info		
-message authentication code	SS calculates the value of MAC-I for this message and writes to this IE. The first/leftmost bit of the bit string contains the most significant bit of the MAC-I.	
-RRC message sequence number	SS provides the value of this IE, from its internal counter.	
-Integrity protection mode info	Not Present	
-Ciphering mode info	Not Present	
-Activation time	Not Present	
-New U-RNTI	Not Present	
-New C-RNTI	Not Present	
-RRC State Indicator	CELL_DCH	
-UTRAN DRX cycle length coefficient	Not Present	
CN Information Elements		
-CN Information info	Not Present	
UTRAN mobility information elements		
-URA identity	Not Present	
RB information elements		
-Downlink counter synchronisation info	Not Present	
PhyCH information elements		
-Frequency info (10.3.6.36)	Not Present	
Uplink radio resources		
-Maximum allowed UL TX power	33 dBm	
-CHOICE <i>channel requirement</i>	Not Present	
Downlink radio resources		
-CHOICE <i>mode</i>	FDD	
-Downlink information common for all radio links (10.3.6.24)		
-Downlink DPCH info common for all RL (10.3.6.18)	Not Present	
-CHOICE <i>mode</i>	FDD	
-DPCH compressed mode info (10.3.6.33)		
- Transmission gap pattern sequence	(1/3 TGPS)	
- TGPSI	1	
- TGPS Status Flag	deactivate	
- Transmission gap pattern sequence		
configuration parameters		
-TGMP	FDD measurement	
-TGPRC	Infinity	
-TGSN	8	
-TGL1	14	
-TGL2	Not Present	
-TGD	UNDEFINED	
-TGPL1	8	
-RPP	mode 0	
-ITP	mode 0	
-CHOICE UL/DL mode	UL and DL	
-Downlink compressed mode method	SF/2	
-Uplink compressed mode method	SF/2	
-Downlink frame type	B	
-DeltaSIR1	3.0	
-DeltaSIRafter1	3.0	
-DeltaSIR2	Not Present	
-DeltaSIRafter2	Not Present	
-N Identify abort	Not Present	
-T Reconfirm abort	Not Present	
- Transmission gap pattern sequence	(2/3 TGPS)	
- TGPSI	2	
- TGPS Status Flag	deactivate	
- Transmission gap pattern sequence		
configuration parameters		

Information Element	Value/Remark	Version
-TGMP	GSM carrier RSSI measurement	
-TGPRC	Infinity	
-TGSN	8	
-TGL1	14	
-TGL2	Not Present	
-TGD	UNDEFINED	
-TGPL1	24	
-RPP	mode 0	
-ITP	mode 0	
-CHOICE UL/DL mode	UL and DL	
-Downlink compressed mode method	SF/2	
-Uplink compressed mode method	SF/2	
-Downlink frame type	B	
-DeltaSIR1	3.0	
-DeltaSIRafter1	3.0	
-DeltaSIR2	Not Present	
-DeltaSIRafter2	Not Present	
-N Identify abort	Not Present	
-T Reconfirm abort	Not Present	
- Transmission gap pattern sequence	(3/3 TGPS)	
- TGPSI	3	
- TGPS Status Flag	deactivate	
- Transmission gap pattern sequence		
configuration parameters		
-TGMP	GSM Initial BSIC identification	
-TGPRC	Infinity	
-TGSN	8	
-TGL1	14	
-TGL2	Not Present	
-TGD	UNDEFINED	
-TGPL1	24	
-RPP	mode 0	
-ITP	mode 0	
-CHOICE UL/DL mode	UL and DL	
-Downlink compressed mode method	SF/2	
-Uplink compressed mode method	SF/2	
-Downlink frame type	B	
-DeltaSIR1	3.0	
-DeltaSIRafter1	3.0	
-DeltaSIR2	Not Present	
-DeltaSIRafter2	Not Present	
-N Identify abort	22	
-T Reconfirm abort	Not Present	
- Transmission gap pattern sequence	4	
- TGPSI	4	
- TGPS Status Flag	deactivate	
- Transmission gap pattern sequence		
configuration parameters		
-TGMP	GSM BSIC re-confirmation	
-TGPRC	Infinity	
-TGSN	8	
-TGL1	14	
-TGL2	Not Present	
-TGD	UNDEFINED	
-TGPL1	24	
-RPP	mode 0	
-ITP	mode 0	
-CHOICE UL/DL mode	UL and DL	
-Downlink compressed mode method	SF/2	
-Uplink compressed mode method	SF/2	
-Downlink frame type	B	
-DeltaSIR1	3.0	
-DeltaSIRafter1	3.0	
-DeltaSIR2	Not Present	
-DeltaSIRafter2	Not Present	
-N Identify abort	Not Present	
-T Reconfirm abort	5.5	

Information Element	Value/Remark	Version
-TX Diversity mode (10.3.6.86)	None	
-Default DPCH Offset Value (10.3.6.16)	Not Present	
-Downlink information per radio link list	1	
-Downlink information for each radio link (10.3.6.27)		
-CHOICE mode	FDD	
-Primary CPICH info (10.3.6.60)		
-Primary scrambling code	Set to Primary scrambling code of Cell1	
-Downlink DPCH info for each RL (10.3.6.21)		
-CHOICE mode	FDD	
-Primary CPICH usage for channel estimation	Primary CPICH may be used	
-DPCH frame offset	Set to value Default DPCH Offset Value (as currently stored in SS) mod 38400	
-Secondary CPICH info	Not Present	
-DL channelisation code		
-Secondary scrambling code	Not Present	
-Spreading factor	128	
-Code number	96	
-Scrambling code change	No change	
-TPC combination index	0	
- Closed loop timing adjustment mode	Not Present	
- SCCPCH information for FACH (10.3.6.70)	Not Present	

PHYSICAL CHANNEL RECONFIGURATION message for Hard Handover:

Information Element	Value/Remark	Version
Message Type		
UE Information Elements		
-RRC transaction identifier	0	
-Integrity check info		
-message authentication code	SS calculates the value of MAC-I for this message and writes to this IE. The first/ leftmost bit of the bit string contains the most significant bit of the MAC-I.	
-RRC message sequence number	SS provides the value of this IE, from its internal counter.	
-Integrity protection mode info	Not Present	
-Ciphering mode info	Not Present	
-Activation time	"now"	
-New U-RNTI	Not Present	
-New C-RNTI	Not Present	
-RRC State Indicator	CELL_DCH	
-UTRAN DRX cycle length coefficient	Not Present	
CN Information Elements		
-CN Information info	Not Present	
UTRAN mobility information elements		
-URA identity	Not Present	
RB information elements		
-Downlink counter synchronisation info	Not Present	
>RB with PDCP information list	Not Present	
>>RB with PDCP information	Not Present	
PhyCH information elements		
-Frequency info (10.3.6.36)		
-CHOICE mode	FDD	
-UARFCN uplink(Nu)	Same uplink UARFCN as used for cell 2	
-UARFCN downlink(Nd)	Same downlink UARFCN as used for cell 2	
Uplink radio resources		
-Maximum allowed UL TX power	33 dBm	
-CHOICE <i>channel requirement</i>	Uplink DPCH info	
-Uplink DPCH info (10.3.6.88)		
-Uplink DPCH power control info (10.3.6.91)		
-CHOICE mode	FDD	
-DPCCH power offset	-40 (-80dB)	
- PC Preamble	1 frame	
- SRB delay	7 frames	
- Power Control Algorithm	Algorithm1	
- TPC step size	1dB	
-CHOICE mode	FDD	
-Scrambling code type	Long	
-Scrambling code number	0 (0 to 16777215)	
-Number of DPDCH	Not Present(1)	
-Spreading factor	64	
-TFCI existence	TRUE	
-Number of FBI bit	Not Present(0)	
-Puncturing Limit	1	
Downlink radio resources		
-CHOICE <i>mode</i>	FDD	
-Downlink information common for all radio links (10.3.6.24)		
-Downlink DPCH info common for all RL (10.3.6.18)		
-Timing indicator	Maintain	
-CFN-targetSFN frame offset	Not Present	
-Downlink DPCH power control information (10.3.6.23)		
-DPC mode	0 (single)	
-CHOICE mode	FDD	
-Power offset $P_{Pilot-DPDCH}$	0	
-DL rate matching restriction information	Not Present	
-Spreading factor	128	
-Fixed or Flexible Position	Fixed	

Information Element	Value/Remark	Version
-TFCI existence	TRUE	
-CHOICE SF	128	
-Number of bits for Pilot bits(SF=128,256)	8	
-CHOICE mode	FDD	
-DPCH compressed mode info (10.3.6.33)	Not Present	
-Default DPCH Offset Value (10.3.6.16)	0	
-Downlink information per radio link list	1	
-Downlink information for each radio link (10.3.6.27)		
-CHOICE mode	FDD	
-Primary CPICH info (10.3.6.60)		
-Primary scrambling code	Set to Primary scrambling code of Cell2	
-Downlink DPCH info for each RL (10.3.6.21)		
-CHOICE mode	FDD	
-Primary CPICH usage for channel estimation	Primary CPICH may be used	
-DPCH frame offset	0 chips	
-Secondary CPICH info	Not Present	
-DL channelisation code		
-Secondary scrambling code	Not Present	
-Spreading factor	128	
-Code number	96	
-Scrambling code change	No change	
-TPC combination index	0	
- Closed loop timing adjustment mode	Not Present	
- SCCPCH information for FACH (10.3.6.70)	Not Present	

MEASUREMENT REPORT message for inter-frequency

These messages are common for all inter-frequency test cases and are described in Annex I.

MEASUREMENT REPORT message for inter-RAT

These messages are common for all inter-RAT test cases and are described in Annex I.

8.6.5.1.5 Test requirements

Table 8.6.5.1.4.4: Cell Specific parameters for Correct reporting of neighbours in AWGN propagation condition

Parameter	Unit	Cell 1					Cell 2					
		T0	T1	T2	T3	T4	T5	T0	T1	T2	T3	T4
UTRA RF Channel Number		Channel 1					Channel 2					
CPICH_Ec/lor	dB	-9.2					-9.2					
PCCPCH_Ec/lor	dB	-11.2					-11.2					
SCH_Ec/lor	dB	-11.2					-11.2					
PICH_Ec/lor	dB	-14.2					-14.2					
DPCH_Ec/lor	dB	Note 1			N/A		N/A			Note 1		
OCNS		Note 2			- 0.941		-0.941			Note 2		
\hat{I}_{or}/I_{oc}	dB	0		-8			-Infinity		0	0	-8	
I_{oc}	dBm/3.8 4 MHz	-60										
CPICH_Ec/lo (Note 3)	dB	-12.2		-17.8			-Infinity		-12.2	-12.2	-17.8	
Note 1: The DPCH level is controlled by the power control loop Note 2: The power of the OCNS channel that is added shall make the total power from the cell to be equal to I_{or} Note 3: These parameters are not directly settable, but are derived by calculation from the settable parameters.												

Table 8.6.5.1.4.5: Cell specific test parameters for Correct reporting of GSM neighbours in AWGN propagation condition (cell 3)

Parameter	Unit	Cell 3				
		T0	T1	T2	T3	T4
Absolute RF Channel Number		ARFCN 1				
RXLEV	dBm	-Infinity			-74	
GSM BSIC		N/A			Valid	Not valid

For the test to pass, the total number of successful tests shall be at least 90% of the cases, with a confidence level of 95%. For the overall outcome of the test to be considered a pass, the counters for 2B events, 3A events and for BSIC events shall independently indicate a pass result.

NOTE: If the above Test Requirement differs from the Minimum Requirement then the Test Tolerance applied for this test is non-zero. The Test Tolerance for this test is defined in clause F.2 and the explanation of how the Minimum Requirement has been relaxed by the Test Tolerance is given in clause F.4.

8.7 Measurements Performance Requirements

Unless explicitly stated:

- Reported measurements shall be within defined range in 90 % of the cases.
- Measurement channel is 12.2 kbps as defined in Annex C, sub-clause C.3.1. This measurement channel is used both in active cell and cells to be measured.
- Physical channels used as defined in Annex E.
- Cell 1 is the active cell.
- Single task reporting.
- Power control is active.

Note: For the UE which supports both Band III and Band IX operating frequencies, the measurement performance requirements for Band III shall apply to the multi-band UE.

8.7.1 CPICH RSCP

8.7.1.1 Intra frequency measurements accuracy

8.7.1.1.1 Absolute accuracy requirement

8.7.1.1.1.1 Definition and applicability

The absolute accuracy of CPICH RSCP is defined as the CPICH RSCP measured from one cell compared to the actual CPICH RSCP power from same cell.

The requirements and this test apply to all types of UTRA for the FDD UE.

8.7.1.1.1.2 Minimum Requirements

The accuracy requirements in table 8.7.1.1.1.1 are valid under the following conditions:

$CPICH_RSCP1|_{dBm} \geq -114$ dBm for Bands I, IV, VI and X,

$CPICH_RSCP1|_{dBm} \geq -113$ dBm for Band IX,

$CPICH_RSCP1|_{dBm} \geq -112$ dBm for Bands II, V, VII and XI,

$CPICH_RSCP1|_{dBm} \geq -111$ dBm for Band III and VIII.

$$\left| \frac{I_o}{\hat{I}_{or}} \right|_{in \text{ dB}} - \left(\frac{CPICH - E_c}{I_{or}} \right)_{in \text{ dB}} \leq 20dB$$

Table 8.7.1.1.1.1: CPICH_RSCP Intra frequency absolute accuracy

Parameter	Unit	Accuracy [dB]		Conditions			
		Normal condition	Extreme condition	Band I, IV, VI and X	Band IX	Band II, V, VII and XI	Band III and VIII
				Io [dBm/3.84 MHz]	Io [dBm/3.84 MHz]	Io [dBm/3.84 MHz]	Io [dBm/3.84 MHz]
CPICH_RSCP	dBm	± 6	± 9	-94...-70	-93...-70	-92...-70	-91...-70
	dBm	± 8	± 11	-70...-50	-70...-50	-70...-50	-70...-70

The normative reference for this requirement is TS 25.133 [2] clauses 9.1.1.1.1 and A.9.1.1.2.

8.7.1.1.1.3 Test purpose

The purpose of this test is to verify that the CPICH RSCP absolute measurement accuracy is within the specified limits in clause 8.7.1.1.2. This measurement is for handover evaluation, DL open loop power control, UL open loop control and for the calculation of pathloss.

8.7.1.1.1.4 Method of test

8.7.1.1.1.4.1 Initial conditions

Test environment: normal, TL/VL, TL/VH, TH/VL, TH/VH; see clauses G.2.1 and G.2.2.

Frequencies to be tested: mid range; see clause G.2.4.

In this case all cells are on the same frequency. CPICH RSCP intra frequency absolute accuracy requirements are tested by using test parameters in table 8.7.1.1.2.

Table 8.7.1.1.1.2: CPICH RSCP Intra frequency parameters

Parameter	Unit	Test 1		Test 2		Test 3		
		Cell 1	Cell 2	Cell 1	Cell 2	Cell 1	Cell 2	
UTRA RF Channel number		Channel 1		Channel 1		Channel 1		
CPICH_Ec/lor	dB	-10		-10		-10		
PCCPCH_Ec/lor	dB	-12		-12		-12		
SCH_Ec/lor	dB	-12		-12		-12		
PICH_Ec/lor	dB	-15		-15		-15		
DPCH_Ec/lor	dB	-15	-	-15	-	-15	-	
OCNS_Ec/lor	dB	-1.11	-0.94	-1.11	-0.94	-1.11	-0.94	
Ioc	Band I, IV, VI, X	dBm/ 3.84 MHz	-75.54	-59.98	-97.47			
	Band IX*				-96.47			
	Band II, V, VII, XI				-95.47			
	Band III, VIII				-94.47			
Ior/Ioc	dB	4	0	9	0	0	-6.53	
CPICH RSCP, Note 1	Band I, IV, VI, X	dBm	-81.5	-85.5	-60.98	-69.88	-107.47	-114.0
	Band IX*						-106.47	-113.0
	Band II, V, VII, XI						-105.47	-112.0
	Band III, VIII						-104.47	-111.0
Io, Note 1	Band I, IV, VI, X	dBm/3.84 MHz	-69	-50	-94			
	Band IX*				-93			
	Band II, V, VII, XI				-92			
	Band III, VIII				-91			
Propagation condition	-	AWGN		AWGN		AWGN		
NOTE 1: CPICH RSCP and Io levels have been calculated from other parameters for information purposes. They are not settable parameters themselves.								
*) For the UE which supports both Band III and Band IX operating frequencies, the measurement performance requirements for Band III shall apply to the multi-band UE.								
Tests shall be done sequentially. Test 1 shall be done first. After test 1 has been executed test parameters for tests 2 and 3 shall be set within 5 seconds so that UE does not loose the Cell 2 in between the tests.								

8.7.1.1.1.4.2 Procedure

- 1) A call is set up according to the test procedure specified in TS 34.108 [3] clause 7.3.2. The RF parameters for Test 1 are set up according to table 8.7.1.1.1.4.
- 2) SS shall transmit MEASUREMENT CONTROL message.
- 3) UE shall transmit periodically MEASUREMENT REPORT messages.
- 4) SS shall check CPICH_RSCP value in MEASUREMENT REPORT messages. CPICH RSCP power of Cell 1 and Cell 2 reported by UE is compared to actual CPICH RSCP power for each MEASUREMENT REPORT message.
- 5) SS shall count number of MEASUREMENT REPORT messages transmitted by UE. After 1000 MEASUREMENT REPORT messages have been received from UE, the RF parameters are set up according to table 8.7.1.1.1.4 for Test 2. While RF parameters are being set up, MEASUREMENT REPORT messages from UE are ignored. SS shall wait for additional 1s and ignore the MEASUREMENT REPORT messages during this period. Then, step 4) above is repeated. After further 1000 MEASUREMENT REPORT messages have been received from UE, the RF parameters are set up according to table 8.7.1.1.1.4 for Test 3. While RF parameters are being set up, MEASUREMENT REPORT messages from UE are ignored. SS shall wait for additional 1s and ignore the MEASUREMENT REPORT messages during this period. Then, step 4) above is repeated.
- 6) After further 1000 MEASUREMENT REPORT messages have been received from UE, the SS shall transmit RRC CONNECTION RELEASE message.
- 7) UE shall transmit RRC CONNECTION RELEASE COMPLETE message.

Specific Message Contents

All messages indicated above shall use the same content as described in the default message content in clause 9 of 34.108 [3], with the following exceptions:

MEASUREMENT CONTROL message for Intra frequency measurement (Step 2):

Information Element	Value/Remark
Message Type	
UE information elements	
-RRC transaction identifier	0
-Integrity check info	
-message authentication code	SS calculates the value of MAC-I for this message and writes to this IE. The first/leftmost bit of the bit string contains the most significant bit of the MAC-I.
-RRC message sequence number	SS provides the value of this IE, from its internal counter.
Measurement Information elements	
-Measurement Identity	1
-Measurement Command	Modify
-Measurement Reporting Mode	
- Measurement Report Transfer Mode	Acknowledged mode RLC
- Periodical Reporting / Event Trigger Reporting Mode	Periodical reporting
-Additional measurement list	Not Present
-CHOICE Measurement Type	Intra-frequency measurement
-Intra-frequency measurement	
- Intra-frequency measurement objects list	Not Present
-Intra-frequency measurement quantity	
-Filter coefficient	0
-CHOICE mode	FDD
-Measurement quantity	CPICH RSCP
-Intra-frequency reporting quantity	
-Reporting quantities for active set cells	
-Cell synchronisation information reporting indicator	TRUE
-Cell Identity reporting indicator	TRUE
-CHOICE mode	FDD
-CPICH Ec/N0 reporting indicator	TRUE
-CPICH RSCP reporting indicator	TRUE
-Pathloss reporting indicator	FALSE
-Reporting quantities for monitored set cells	
-Cell synchronisation information reporting indicator	FALSE
-Cell Identity reporting indicator	TRUE
-CHOICE mode	FDD
-CPICH Ec/N0 reporting indicator	TRUE
-CPICH RSCP reporting indicator	TRUE
-Pathloss reporting indicator	FALSE
-Reporting quantities for detected set cells	Not Present
-Reporting cell status	
-CHOICE reported cell	Report all active set cells + cells within monitored set on used frequency
-Maximum number of reported cells	Virtual/active set cells + 2
-Measurement validity	Not Present
-CHOICE <i>report criteria</i>	Periodical reporting criteria
-Amount of reporting	Infinity
-Reporting interval	250 ms
Physical channel information elements	
-DPCH compressed mode status info	Not Present

MEASUREMENT REPORT message for Intra frequency test cases

This message is common for all intra frequency test cases in clause 8.7 and is described in Annex I.

8.7.1.1.1.5 Test requirements

Table 8.7.1.1.1.3: CPICH_RSCP Intra frequency absolute accuracy, test requirement

Parameter	Unit	Accuracy [dB]		Conditions			
		Normal condition	Extreme condition	I _o [dBm/3.84 MHz]			
				Band I, IV, VI and X	Band IX	Band II, V, VII and XI	Band III, VIII
CPICH_RSCP	dBm	±7.4	±10.4	-94...-70	-93...-70	-92...-70	-91...-70
	dBm	±9.4	±12.4	-70...-50	-70...-50	-70...-50	-70...-50

Table 8.7.1.1.1.4: CPICH RSCP Intra frequency test parameters

Parameter		Unit	Test 1		Test 2		Test 3	
			Cell 1	Cell 2	Cell 1	Cell 2	Cell 1	Cell 2
UTRA RF Channel number			Channel 1		Channel 1		Channel 1	
CPICH_Ec/lor		dB	-10		-10		-10	
PCCPCH_Ec/lor		dB	-12		-12		-12	
SCH_Ec/lor		dB	-12		-12		-12	
PICH_Ec/lor		dB	-15		-15		-15	
DPCH_Ec/lor		dB	-15	-	-15	-	-15	-
OCNS_Ec/lor		dB	-1.11	-0.94	-1.11	-0.94	-1.11	-0.94
I _{oc}	Band I, IV, VI, X	dBm/ 3.84 MHz	-74.54		-61,6		-96.47	
	Band IX*						-95.47	
	Band II, V, VII, XI						-94.47	
	Band III, VIII						-93.47	
I _{or} /I _{oc}		dB	4.3	0.3	9.3	0.3	0.3	-6.23
CPICH RSCP, Note 1	Band I, IV, VI, X	dBm	-80.2	-84.2	-62.3	-71.3	-106.17	
	Band IX*						-112.7	
	Band II, V, VII, XI						-105.17	
	Band III, VIII						-111.7	
I _o , Note 1	Band I, IV, VI, X	dBm / 3.84 MHz	-67.8		-51,4		-92,8	
	Band IX*						-91.8	
	Band II, V, VII, XI						-90.8	
	Band III, VIII						-89.8	
Propagation condition		-	AWGN		AWGN		AWGN	
NOTE 1: CPICH RSCP and I _o levels have been calculated from other parameters for information purposes. They are not settable parameters themselves.								
*) For the UE which supports both Band III and Band IX operating frequencies, the measurement performance requirements for Band III shall apply to the multi-band UE.								
Tests shall be done sequentially. Test 1 shall be done first. After test 1 has been executed test parameters for tests 2 and 3 shall be set within 5 seconds so that UE does not loose the Cell 2 in between the tests.								

The reported values for the absolut intra frequency CPICH RSCP measurement shall meet the requirements in table 8.7.1.1.1.5.

Table 8.7.1.1.1.5: CPICH_RSCP Intra frequency absolute accuracy requirements for the reported values

	Test 1	Test 2	Test 3 (Band I, IV, VI and X)	Test 3 (Band IX)	Test 3 (Band II,V, VII and XI)	Test 3 (Band III, VIII)
Normal Conditions						
Lowest reported value (Cell 1)	CPICH_RSCP _26	CPICH_RSCP _44	CPICH_RSCP _2	CPICH_RSCP _3	CPICH_RSCP _4	CPICH_RSCP _5
Highest reported value (Cell 1)	CPICH_RSCP _45	CPICH_RSCP _63	CPICH_RSCP _17	CPICH_RSCP _18	CPICH_RSCP _19	CPICH_RSCP _20
Lowest reported value (Cell 2)	CPICH_RSCP _22	CPICH_RSCP _35	CPICH_RSCP -5 (NOTE 2)	CPICH_RSCP -4 (NOTE 2)	CPICH_RSCP -3 (NOTE 2)	CPICH_RSCP -2 (NOTE 2)
Highest reported value (Cell 2)	CPICH_RSCP _41	CPICH_RSCP _54	CPICH_RSCP _10	CPICH_RSCP _11	CPICH_RSCP _12	CPICH_RSCP _13
Extreme Conditions						
Lowest reported value (Cell 1)	CPICH_RSCP _23	CPICH_RSCP _41	CPICH_RSCP -1 (NOTE 2)	CPICH_RSCP _0	CPICH_RSCP _1	CPICH_RSCP _2
Highest reported value (Cell 1)	CPICH_RSCP _48	CPICH_RSCP _66	CPICH_RSCP _20	CPICH_RSCP _21	CPICH_RSCP _22	CPICH_RSCP _23
Lowest reported value (Cell 2)	CPICH_RSCP _19	CPICH_RSCP _32	CPICH_RSCP -5 (NOTE 2)	CPICH_RSCP -5 (NOTE 2)	CPICH_RSCP -5 (NOTE 2)	CPICH_RSCP -5 (NOTE 2)
Highest reported value (Cell 2)	CPICH_RSCP _44	CPICH_RSCP _57	CPICH_RSCP _13	CPICH_RSCP _14	CPICH_RSCP _15	CPICH_RSCP _16

NOTE 1: If the above Test Requirement differs from the Minimum Requirement then the Test Tolerance applied for this test is non-zero. The Test Tolerance for this test is defined in clause F.2 and the explanation of how the Minimum Requirement has been relaxed by the Test Tolerance is given in clause F.4.

NOTE 2: This value applies for a UE complying to release 5 or later. The corresponding value for a pre-release 5 UE is CPICH_RSCP_0.

8.7.1.1.2 Relative accuracy requirement

8.7.1.1.2.1 Definition and applicability

The relative accuracy of CPICH RSCP is defined as the CPICH RSCP measured from one cell compared to the CPICH RSCP measured from another cell on the same frequency.

The requirements and this test apply to all types of UTRA for the FDD UE.

8.7.1.1.2.2 Minimum Requirements

The accuracy requirements in table 8.7.1.1.2.1 are valid under the following conditions:

CPICH_RSCP1,2|_{dBm} ≥ -114 dBm for Bands I, IV, VI and X,

CPICH_RSCP1,2|_{dBm} ≥ -113 dBm for Band IX,

CPICH_RSCP1,2|_{dBm} ≥ -112 dBm for Bands II, V, VII and XI,

CPICH_RSCP1,2|_{dBm} ≥ -111 dBm for Band III and VIII.

$$\left| CPICH_RSCP1 \Big|_{in\ dBm} - CPICH_RSCP2 \Big|_{in\ dBm} \right| \leq 20dB$$

$$\left| \frac{I_o}{\hat{I}_{or}} \right|_{in\ dB} - \left(\frac{CPICH_E_c}{I_{or}} \right) \Big|_{in\ dB} \leq 20dB$$

Table 8.7.1.1.2.1: CPICH_RSCP Intra frequency relative accuracy

Parameter	Unit	Accuracy [dB]		Conditions			
		Normal condition	Extreme condition	Band I, IV, VI and X	Band IX	Band II,V, VII and XI	Band III and VIII
				Io [dBm/3.84 MHz]	Io [dBm/3.84 MHz]	Io [dBm/3.84 MHz]	Io [dBm/3.84 MHz]
CPICH_RSCP	dBm	± 3	± 3	-94...-50	-93...-50	-92...-50	-91...-50

The normative reference for this requirement is TS 25.133 [2] clauses 9.1.1.1.2 and A.9.1.1.2.

8.7.1.1.2.3 Test purpose

The purpose of this test is to verify that the CPICH RSCP relative measurement accuracy is within the specified limits in clause 8.7.1.1.2.2. This measurement is for handover evaluation, DL open loop power control, UL open loop control and for the calculation of pathloss.

8.7.1.1.2.4 Method of test

8.7.1.1.2.4.1 Initial conditions

Test environment: normal, TL/VL, TL/VH, TH/VL, TH/VH; see clauses G.2.1 and G.2.2.

Frequencies to be tested: mid range; see clause G.2.4.

In this case all cells are on the same frequency. CPICH RSCP intra frequency relative accuracy requirements are tested by using test parameters in table 8.7.1.1.1.2.

8.7.1.1.2.4.2 Procedure

- 1) A call is set up according to the test procedure specified in TS 34.108 [3] clause 7.3.2. The RF parameters for Test 1 are set up according to table 8.7.1.1.2.3.
- 2) SS shall transmit MEASUREMENT CONTROL message.
- 3) UE shall transmit periodically MEASUREMENT REPORT messages.
- 4) SS shall check CPICH_RSCP value of Cell 1 and Cell 2 in MEASUREMENT REPORT messages. CPICH RSCP power value measured from Cell 1 is compared to CPICH RSCP power value measured from Cell 2 for each MEASUREMENT REPORT message.
- 5) The result of step 3) is compared to actual power level difference of CPICH RSCP of Cell 1 and Cell 2.
- 6) SS shall count number of MEASUREMENT REPORT messages transmitted by UE. After 1000 MEASUREMENT REPORT messages have been received from UE, the RF parameters are set up according to table 8.7.1.1.2.3 for Test 2. While RF parameters are being set up, MEASUREMENT REPORT messages from UE are ignored. SS shall wait for additional 1s and ignore the MEASUREMENT REPORT messages during this period. Then, steps 4) and 5) above are repeated. After further 1000 MEASUREMENT REPORT messages have been received from UE, the RF parameters are set up according to table 8.7.1.1.2.3 for Test 3. While RF parameters are being set up, MEASUREMENT REPORT messages from UE are ignored. SS shall wait for additional 1s and ignore the MEASUREMENT REPORT messages during this period. Then, steps 4) and 5) above are repeated.
- 7) After further 1000 MEASUREMENT REPORT messages have been received from UE, the SS shall transmit RRC CONNECTION RELEASE message.
- 8) UE shall transmit RRC CONNECTION RELEASE COMPLETE message.

Specific Message Contents

All messages indicated above shall use the same content as described in the default message content in clause 9 of 34.108 [3], with the following exceptions:

MEASUREMENT CONTROL message for Intra frequency measurement in clause 8.7.1.1.1.4.2 is used.

MEASUREMENT REPORT message for Intra frequency test cases

This message is common for all intra frequency test cases in clause 8.7 and is described in Annex I.

8.7.1.1.2.5 Test requirements

Table 8.7.1.1.2.2: CPICH_RSCP Intra frequency relative accuracy, test requirements

Parameter	Unit	Accuracy [dB]		Conditions			
		Normal condition	Extreme condition	Io [dBm/3.84 MHz]			
				Band I, IV, VI and X	Band IX	Band II, V, VII and XI	Band III and VIII
CPICH_RSCP	dBm	±3.8	±3.8	-94...-50	-93...-50	-92...-50	-91...-50

Table 8.7.1.1.2.3: CPICH RSCP Intra frequency test parameters

Parameter	Unit	Test 1		Test 2		Test 3		
		Cell 1	Cell 2	Cell 1	Cell 2	Cell 1	Cell 2	
UTRA RF Channel number		Channel 1		Channel 1		Channel 1		
CPICH_Ec/Ior	dB	-10		-10		-10		
PCCPCH_Ec/Ior	dB	-12		-12		-12		
SCH_Ec/Ior	dB	-12		-12		-12		
PICH_Ec/Ior	dB	-15		-15		-15		
DPCH_Ec/Ior	dB	-15	-	-15	-	-15	-	
OCNS_Ec/Ior	dB	-1.11	-0.94	-1.11	-0.94	-1.11	-0.94	
Ior	Band I, IV, VI, X	dBm/ 3.84 MHz	-74.54	-61,6	-96.47			
	Band IX*				-95.47			
	Band II, V, VII, XI				-94.47			
	Band III, VIII				-93.47			
Ior/Ioc	dB	4.3	0.3	9.3	0.3	0.3	-6.23	
CPICH RSCP, Note 1	Band I, IV, VI, X	dBm	-80.2	-84.2	-62.3	-71.3	-106.17	-112.7
	Band IX*						-105.17	-111.7
	Band II, V, VII, XI						-104.17	-110.7
	Band III, VIII						-103.17	-109.7
Io, Note 1	Band I, IV, VI, X	dBm/ 3.84 MHz	-67.8	-51,4	-92,8			
	Band IX*				-91.8			
	Band II, V, VII, XI				-90.8			
	Band III, VIII				-89.8			
Propagation condition	-	AWGN		AWGN		AWGN		
NOTE 1: CPICH RSCP and Io levels have been calculated from other parameters for information purposes. They are not settable parameters themselves.								
*) For the UE which supports both Band III and Band IX operating frequencies, the measurement performance requirements for Band III shall apply to the multi-band UE.								
Tests shall be done sequentially. Test 1 shall be done first. After test 1 has been executed test parameters for tests 2 and 3 shall be set within 5 seconds so that UE does not loose the Cell 2 in between the tests.								

The reported values for the relative intra frequency CPICH RSCP measurement shall meet the requirements in table 8.7.1.1.2.4.

Table 8.7.1.1.2.4: CPICH_RSCP Intra frequency relative accuracy requirements for the reported values

	Test 1	Test 2	Test 3
Normal Conditions			
Lowest reported value cell 2	CPICH_RSCP_(x - 8)	CPICH_RSCP_(x - 13)	CPICH_RSCP_(x - 11)
Highest reported value cell 2	CPICH_RSCP_x	CPICH_RSCP_(x - 5)	CPICH_RSCP_(x - 3)
Extreme Conditions			
Lowest reported value cell2	CPICH_RSCP_(x - 8)	CPICH_RSCP_(x - 13)	CPICH_RSCP_(x - 11)
Highest reported value cell2	CPICH_RSCP_x	CPICH_RSCP_(x - 5)	CPICH_RSCP_(x - 3)
CPICH_RSCP_x is the reported value of cell 1			

NOTE: If the above Test Requirement differs from the Minimum Requirement then the Test Tolerance applied for this test is non-zero. The Test Tolerance for this test is defined in clause F.2 and the explanation of how the Minimum Requirement has been relaxed by the Test Tolerance is given in clause F.4.

8.7.1.2 Inter frequency measurement accuracy

8.7.1.2.1 Relative accuracy requirement

8.7.1.2.1.1 Definition and applicability

The relative accuracy of CPICH RSCP in inter frequency case is defined as the CPICH RSCP measured from one cell compared to the CPICH RSCP measured from another cell on a different frequency.

The requirements and this test apply to all types of UTRA for the FDD UE.

8.7.1.2.1.2 Minimum Requirements

The accuracy requirements in table 8.7.1.2.1.1 are valid under the following conditions:

CPICH_RSCP_{1,2|dBm} ≥ -114 dBm for Bands I, IV, VI and X,

CPICH_RSCP_{1,2|dBm} ≥ -113 dBm for Band IX,

CPICH_RSCP_{1,2|dBm} ≥ -112 dBm for Bands II, V, VII and XI,

CPICH_RSCP_{1,2|dBm} ≥ -111 dBm for Band III and VIII.

$$\left| CPICH_RSCP1 \Big|_{in\ dBm} - CPICH_RSCP2 \Big|_{in\ dBm} \right| \leq 20dB$$

$$| Channel\ 1_Io|_{dBm/3.84\ MHz} - Channel\ 2_Io|_{dBm/3.84\ MHz} | \leq 20\ dB.$$

$$\left(\frac{I_o}{\hat{I}_{or}} \right) \Big|_{in\ dB} - \left(\frac{CPICH - E_c}{I_{or}} \right) \Big|_{in\ dB} \leq 20dB$$

Table 8.7.1.2.1.1: CPICH_RSCP Inter frequency relative accuracy

Parameter	Unit	Accuracy [dB]		Conditions			
		Normal condition	Extreme condition	Band I, IV, VI and X	Band IX	Band II, V, VII and XI	Band III and VIII
				Io [dBm/3.84 MHz]	Io [dBm/3.84 MHz]	Io [dBm/3.84 MHz]	Io [dBm/3.84 MHz]
CPICH_RSCP	dBm	± 6	± 6	-94...-50	-93...-50	-92...-50	-91...-50

The normative reference for this requirement is TS 25.133 [2] clauses 9.1.1.2.1 and A.9.1.1.2.

8.7.1.2.1.3 Test purpose

The purpose of this test is to verify that the CPICH RSCP relative measurement accuracy is within the specified limits in clause 8.7.1.2.1.2. This measurement is for handover evaluation, DL open loop power control, UL open loop control and for the calculation of pathloss.

8.7.1.2.1.4 Method of test

8.7.1.2.1.4.1 Initial conditions

Test environment: normal, TL/VL, TL/VH, TH/VL, TH/VH; see clauses G.2.1 and G.2.2.

Frequencies to be tested: mid range; see clause G.2.4.

In this case both cells are on different frequencies and compressed mode is applied. The gap length is 7, detailed definition is in clause C.5, set 1 of table C.5.2 except for TGRRC and TGCFN. TGPRC and TGCFN shall set to "Infinity" and "(Current CFN + (256 – TTI/10msec))mod 256". CPICH RSCP inter frequency relative accuracy requirements are tested by using test parameters in table 8.7.1.2.1.2.

Table 8.7.1.2.1.2: CPICH RSCP Inter frequency parameters

Parameter		Unit	Test 1		Test 2	
			Cell 1	Cell 2	Cell 1	Cell 2
UTRA RF Channel number			Channel 1	Channel 2	Channel 1	Channel 2
CPICH_Ec/lor		dB	-10		-10	
PCCPCH_Ec/lor		dB	-12		-12	
SCH_Ec/lor		dB	-12		-12	
PICH_Ec/lor		dB	-15		-15	
DPCH_Ec/lor		dB	-15	-	-15	-
OCNS_Ec/lor		dB	-1.11	-0.94	-1.11	-0.94
lor	Band I, IV, VI, X	dBm/ 3.84 MHz	-60.00	-60.00	-84.00	-94.46
	Band IX*				-83.00	-93.46
	Band II, V, VII, XI				-82.00	-92.46
	Band III, VIII				-81.00	-91.46
lor/lor		dB	9.54	9.54	0	-9.54
CPICH RSCP, Note 1	Band I, IV, VI, X	dBm	-60.46	-60.46	-94.0	-114.0
	Band IX*				-93.0	-113.0
	Band II, V, VII, XI				-92.0	-112.0
	Band III, VIII				-91.0	-111.0
lo, Note 1	Band I, IV, VI, X	dBm/3.84 MHz	-50.00	-50.00	-81.0	-94.0
	Band IX*				-80.0	-93.0
	Band II, V, VII, XI				-79.0	-92.0
	Band III, VIII				-78.0	-91.0
Propagation condition		-	AWGN		AWGN	
NOTE 1: CPICH RSCP and lo levels have been calculated from other parameters for information purposes. They are not settable parameters themselves.						
*) For the UE which supports both Band III and Band IX operating frequencies, the measurement performance requirements for Band III shall apply to the multi-band UE.						
Tests shall be done sequentially. Test 1 shall be done first. After test 1 has been executed test parameters for test 2 shall be set within 5 seconds so that UE does not loose the Cell 2 in between the tests.						

8.7.1.2.1.4.2 Procedure

- 1) A call is set up according to the test procedure specified in TS 34.108 [3] clause 7.3.2. The RF parameters for Test 1 are set up according to table 8.7.1.2.1.4.
- 2) SS shall transmit PHYSICAL CHANNEL RECONFIGURATION message.
- 3) UE shall transmit PHYSICAL CHANNEL RECONFIGURATION COMPLETE message.
- 4) SS shall transmit MEASUREMENT CONTROL message for intra frequency measurement and transmit MEASUREMENT CONTROL message for inter frequency measurement.
- 5) UE shall transmit periodically MEASUREMENT REPORT messages.

- 6) SS shall check CPICH_RSCP value of Cell 1 and Cell 2 in MEASUREMENT REPORT messages. CPICH RSCP power value measured from Cell 1 is compared to CPICH RSCP power value measured from Cell 2 for each MEASUREMENT REPORT message.
- 7) The result of step 5) is compared to actual power level difference of CPICH RSCP of Cell 1 and Cell 2.
- 8) SS shall count number of MEASUREMENT REPORT messages transmitted by UE. After 1000 MEASUREMENT REPORT messages have been received from UE, the RF parameters are set up according to table 8.7.1.2.1.4 for Test 2. While RF parameters are being set up, MEASUREMENT REPORT messages from UE are ignored. SS shall wait for additional 1s and ignore the MEASUREMENT REPORT messages during this period. Then, steps 6) and 7) above are repeated.
- 9) After further 1000 MEASUREMENT REPORT messages have been received from UE, the SS shall transmit RRC CONNECTION RELEASE message.
- 10) UE shall transmit RRC CONNECTION RELEASE COMPLETE message.

Specific Message Contents

All messages indicated above shall use the same content as described in the default message content in clause 9 of 34.108 [3], with the following exceptions:

PHYSICAL CHANNEL RECONFIGURATION message for Inter frequency measurement (step 1):

Information Element	Value/Remark	Version
Message Type		
UE Information Elements		
-RRC transaction identifier	0	
-Integrity check info		
-message authentication code	SS calculates the value of MAC-I for this message and writes to this IE. The first/ leftmost bit of the bit string contains the most significant bit of the MAC-I.	
-RRC message sequence number	SS provides the value of this IE, from its internal counter.	
-Integrity protection mode info	Not Present	
-Ciphering mode info	Not Present	
-Activation time	Not Present	
-New U-RNTI	Not Present	
-New C-RNTI	Not Present	
-RRC State Indicator	CELL_DCH	
-UTRAN DRX cycle length coefficient	Not Present	
CN Information Elements		
-CN Information info	Not Present	
UTRAN mobility information elements		
-URA identity	Not Present	
RB information elements		
-Downlink counter synchronisation info	Not Present	
PhyCH information elements		
-Frequency info	Not Present	
Uplink radio resources		
-Maximum allowed UL TX power	Not Present	
- CHOICE channel requirement	Not Present	
Downlink radio resources		
-CHOICE mode	FDD	
-Downlink PDSCH information	Not Present	R99 and Rel-4 only
-Downlink information common for all radio links		
-Downlink DPCH info common for all RL	Not Present	
-CHOICE mode	FDD	
-DPCH compressed mode info		
-Transmission gap pattern sequence		
-TGPSI	1	
-TGPS Status Flag	Activate	
-TGCFN	(Current CFN + (256 – TTI/10msec))mod 256	
-Transmission gap pattern sequence configuration parameters		
-TGMP	FDD measurement	
-TGPRC	Infinity	
-TGSN	4	
-TGL1	7	
-TGL2	Not Present	
-TGD	UNDEFINED	
-TGPL1	3	
-TGPL2	Not Present	R99 and Rel-4 only
-RPP	Mode 0	
-ITP	Mode 0	
-CHOICE UL/DL mode	UL and DL	
-Downlink compressed mode method	SF/2	
-Uplink compressed mode method	SF/2	
-Downlink frame type	B	
-DeltaSIR1	3.0	
-DeltaSIRafter1	3.0	
-DeltaSIR2	Not Present	
-DeltaSIRafter2	Not Present	
-N Identify abort	Not Present	
-T Reconfirm abort	Not Present	
-TX Diversity Mode	Not Present	
-SSDT information	Not Present	R99 and

-Default DPCH Offset Value	Not Present	Rel-4 only
-Downlink information per radio link list		
-Downlink information for each radio link		
-Choice mode	FDD	
-Primary CPICH info		
-Primary scrambling code	100	
-PDSCH with SHO DCH Info	Not Present	R99 and Rel-4 only
-PDSCH code mapping	Not Present	R99 and Rel-4 only
-Downlink DPCH info for each RL		
-CHOICE mode	FDD	
-Primary CPICH usage for channel estimation	Primary CPICH may be used	
-DPCH frame offset	Set to value Default DPCH Offset Value (as currently stored in SS) mod 38400	
-Secondary CPICH info	Not Present	
-DL channelisation code		
-Secondary scrambling code	Not Present	
-Spreading factor	128	
-Code number	96	
-Scrambling code change	No code change	
-TPC combination index	0	
-SSDT Cell Identity	Not Present	R99 and Rel-4 only
-Closed loop timing adjustment mode	Not Present	
-SCCPCH Information for FACH	Not Present	

First MEASUREMENT CONTROL message for Intra frequency measurement (Step 3):

Information Element	Value/Remark
Message Type	
UE information elements	
-RRC transaction identifier	0
-Integrity check info	
-message authentication code	SS calculates the value of MAC-I for this message and writes to this IE. The first/leftmost bit of the bit string contains the most significant bit of the MAC-I.
-RRC message sequence number	SS provides the value of this IE, from its internal counter.
Measurement Information elements	
-Measurement Identity	1
-Measurement Command	Modify
-Measurement Reporting Mode	
- Measurement Report Transfer Mode	Acknowledged mode RLC
- Periodical Reporting / Event Trigger Reporting Mode	Periodical reporting
-Additional measurement list	Not Present
-CHOICE Measurement Type	Intra-frequency measurement
-Intra-frequency measurement	
- Intra-frequency measurement objects list	
-Intra-frequency cell info list	Not Present
-Intra-frequency measurement quantity	
-Filter coefficient	0
-CHOICE mode	FDD
-Measurement quantity	CPICH RSCP
-Intra-frequency reporting quantity	
-Reporting quantities for active set cells	
-Cell synchronisation information reporting indicator	TRUE
-Cell Identity reporting indicator	TRUE
-CHOICE mode	FDD
-CPICH Ec/N0 reporting indicator	TRUE
-CPICH RSCP reporting indicator	TRUE
-Pathloss reporting indicator	FALSE
-Reporting quantities for monitored set cells	
-Cell synchronisation information reporting indicator	FALSE
-Cell Identity reporting indicator	TRUE
-CHOICE mode	FDD
-CPICH Ec/N0 reporting indicator	TRUE
-CPICH RSCP reporting indicator	TRUE
-Pathloss reporting indicator	FALSE
-Reporting quantities for detected set cells	Not Present
-Reporting cell status	
-CHOICE reported cell	Report all active set cells + cells within monitored set on used frequency
-Maximum number of reported cells	Virtual/active set cells + 2
-Measurement validity	Not Present
-CHOICE <i>report criteria</i>	Periodical reporting criteria
-Amount of reporting	Infinity
-Reporting interval	250 ms
Physical channel information elements	
-DPCH compressed mode status info	Not Present

Second MEASUREMENT CONTROL message for Inter frequency measurement (step 3):

Information Element	Value/Remark
Message Type UE information elements -RRC transaction identifier -Integrity check info -message authentication code -RRC message sequence number	0 SS calculates the value of MAC-I for this message and writes to this IE. The first/leftmost bit of the bit string contains the most significant bit of the MAC-I. SS provides the value of this IE, from its internal counter.
Measurement Information elements -Measurement Identity -Measurement Command -Measurement Reporting Mode - Measurement Report Transfer Mode - Periodical Reporting / Event Trigger Reporting Mode -Additional measurement list -CHOICE Measurement Type -Inter-frequency measurement object list -CHOICE Inter-frequency cell removal -New inter-frequency cells -Cell for measurement -Inter-frequency measurement quantity -CHOICE reporting criteria -Filter coefficient -CHOICE mode -Measurement quantity for frequency quality estimate -Inter-frequency reporting quantity -UTRA Carrier RSSI -Frequency quality estimate -Non frequency related cell reporting quantities -Cell synchronisation information reporting indicator -Cell Identity reporting indicator -CHOICE mode -CPICH Ec/N0 reporting indicator -CPICH RSCP reporting indicator -Pathloss reporting indicator -Reporting cell status -CHOICE reported cell -Maximum number of reported cells -Measurement validity -Inter-frequency set update -CHOICE report criteria -Amount of reporting -Reporting interval	2 Setup Acknowledged mode RLC Periodical reporting Not Present Inter-frequency measurement Not Present Cell 2 information is included Not Present Inter-frequency reporting criteria 0 FDD CPICH RSCP TRUE TRUE TRUE TRUE FDD TRUE TRUE FALSE Report cells within monitored set on non-used frequency 2 Not Present Not Present Periodical reporting criteria Infinity 500 ms
Physical channel information elements -DPCH compressed mode status info	Not Present

MEASUREMENT REPORT message for Inter frequency test cases

This message is common for all inter frequency test cases in clause 8.7 and is described in Annex I.

8.7.1.2.1.5 Test requirements

Table 8.7.1.2.1.3: CPICH_RSCP Inter frequency relative accuracy, test requirements

Parameter	Unit	Accuracy [dB]		Conditions			
		Normal condition	Extreme condition	Io [dBm/3.84 MHz]			
				Band I, IV, VI and X	Band IX	Band II, V, VII and XI	Band III and VIII
CPICH_RSCP	dBm	±7.1	±7.1	-94...-50	-93...-50	-92...-50	-91...-50

Table 8.7.1.2.1.4: CPICH RSCP Inter frequency tests parameters

Parameter	Unit	Test 1		Test 2		
		Cell 1	Cell 2	Cell 1	Cell 2	
UTRA RF Channel number		Channel 1	Channel 2	Channel 1	Channel 2	
CPICH_Ec/Ior	dB	-10		-10		
PCCPCH_Ec/Ior	dB	-12		-12		
SCH_Ec/Ior	dB	-12		-12		
PICH_Ec/Ior	dB	-15		-15		
DPCH_Ec/Ior	dB	-15	-	-15	-	
OCNS_Ec/Ior	dB	-1.11	-0.94	-1.11	-0.94	
Ior	Band I, IV, VI, X	dBm/ 3.84 MHz	-61.6	-61.6	-83.00	-93.46
	Band IX*				-82.00	-92.46
	Band II, V, VII, XI				-81.00	-91.46
	Band III, VIII				-80.00	-90.46
Ior/Ior	dB	9.84	9.84	0.3	-9.24	
CPICH RSCP, Note 1	Band I, IV, VI, X	dBm	-61.8	-61.8	-92.7	-112.7
	Band IX*				-91.7	-111.7
	Band II, V, VII, XI				-90.7	-110.7
	Band III, VIII				-89.7	-109.7
Io, Note 1	Band I, IV, VI, X	dBm/3.84 MHz	-51.3	-51.3	-79.8	-93.0
	Band IX*				-78.8	-92.0
	Band II, V, VII, XI				-77.8	-91.0
	Band III, VIII				-76.8	-90.0
Propagation condition	-	AWGN		AWGN		
NOTE 1: CPICH RSCP and Io levels have been calculated from other parameters for information purposes. They are not settable parameters themselves.						
*) For the UE which supports both Band III and Band IX operating frequencies, the measurement performance requirements for Band III shall apply to the multi-band UE.						
Tests shall be done sequentially. Test 1 shall be done first. After test 1 has been executed test parameters for test 2 shall be set within 5 seconds so that UE does not loose the Cell 2 in between the tests.						

The reported values for the relative inter frequency CPICH RSCP measurement shall meet the requirements in table 8.7.1.2.1.5.

Table 8.7.1.2.1.5: CPICH_RSCP Inter frequency relative accuracy requirements for the reported values

	Test 1	Test 2
Normal Conditions		
Lowest reported value cell 2	CPICH_RSCP_(x - 8)	CPICH_RSCP_(x - 28)
Highest reported value cell 2	CPICH_Ec/No_(x + 8)	CPICH_Ec/No_(x - 12)
Extreme Conditions		
Lowest reported value cell2	CPICH_RSCP_(x - 8)	CPICH_RSCP_(x - 28)
Highest reported value cell2	CPICH_Ec/No_(x + 8)	CPICH_Ec/No_(x - 12)
CPICH_RSCP_x is the reported value of cell 1		

NOTE: If the above Test Requirement differs from the Minimum Requirement then the Test Tolerance applied for this test is non-zero. The Test Tolerance for this test is defined in clause F.2 and the explanation of how the Minimum Requirement has been relaxed by the Test Tolerance is given in clause F.4.

8.7.2 CPICH Ec/Io

8.7.2.1 Intra frequency measurements accuracy

8.7.2.1.1 Absolute accuracy requirement

8.7.2.1.1.1 Definition and applicability

The absolute accuracy of CPICH Ec/Io is defined as the CPICH Ec/Io measured from one cell compared to the actual CPICH_Ec/Io power ratio from same cell.

The requirements and this test apply to all types of UTRA for the FDD UE.

8.7.2.1.1.2 Minimum Requirements

The accuracy requirements in table 8.7.2.1.1.1 are valid under the following conditions:

CPICH_RSCP1_{dBm} ≥ -114 dBm for Bands I, IV, VI and X,

CPICH_RSCP1_{dBm} ≥ -113 dBm for Band IX,

CPICH_RSCP1_{dBm} ≥ -112 dBm for Bands II, V, VII and XI,

CPICH_RSCP1_{dBm} ≥ -111 dBm for Band III and VIII.

$$\left| \frac{I_o}{\hat{I}_{or}} \right|_{in\ dB} - \left(\frac{CPICH_Ec}{I_{or}} \right)_{in\ dB} \leq 20dB$$

Table 8.7.2.1.1.1: CPICH_Ec/Io Intra frequency absolute accuracy, minimum requirements

Parameter	Unit	Accuracy [dB]		Conditions			
		Normal condition	Extreme condition	Band I, IV, VI and X	Band IX	Band II, V, VII, and XI	Band III and VIII
				I _o [dBm/3.84 MHz]	I _o [dBm/3.84 MHz]	I _o [dBm/3.84 MHz]	I _o [dBm/3.84 MHz]
CPICH_Ec/Io	dB	± 1.5 for -14 ≤ CPICH Ec/Io ± 2 for -16 ≤ CPICH Ec/Io < -14 ± 3 for -20 ≤ CPICH Ec/Io < -16	± 3	-94...-50	-93...-50	-92...-50	-91...-50

The normative reference for this requirement is TS 25.133 [2] clause 9.1.2.1.1.

8.7.2.1.1.3 Test purpose

The purpose of this test is to verify that the CPICH Ec/Io absolute measurement accuracy is within the specified limits in clause 8.7.2.1.1.2. This measurement is for Cell selection/re-selection and for handover evaluation.

8.7.2.1.1.4 Method of test

8.7.2.1.1.4.1 Initial conditions

Test environment: normal, TL/VL, TL/VH, TH/VL, TH/VH; see clauses G.2.1 and G.2.2.

Frequencies to be tested: mid range; see clause G.2.4.

In this case all cells are on the same frequency. CPICH Ec/Io intra frequency absolute accuracy requirements are tested by using the test parameters in table 8.7.2.1.1.2.

Table 8.7.2.1.1.2: CPICH_Ec/Io Intra frequency parameters

Parameter		Unit	Test 1		Test 2		Test 3	
			Cell 1	Cell 2	Cell 1	Cell 2	Cell 1	Cell 2
UTRA RF Channel number			Channel 1		Channel 1		Channel 1	
CPICH_Ec/Io		dB	-10		-10		-10	
PCCPCH_Ec/Io		dB	-12		-12		-12	
SCH_Ec/Io		dB	-12		-12		-12	
PICH_Ec/Io		dB	-15		-15		-15	
DPCH_Ec/Io		dB	-15	-	-15	-	-6	-
OCNS_Ec/Io		dB	-1.11	-0.94	-1.11	-0.94	-2.56	-0.94
Ioc	Band I, IV, VI, X	dBm/ 3.84 MHz	-56.98		-89.07		-94.98	
	Band IX*				-88.07		-93.98	
	Band II, V, VII, XI				-87.07		-92.98	
	Band III, VIII				-86.07		-91.98	
Ior/Ioc		dB	3.0	3.0	-2.9	-2.9	-9.0	-9.0
CPICH Ec/Io, Note 1		dBm	-14.0	-14.0	-16.0	-16.0	-20.0	-20.0
Io, Note 1	Band I, IV, VI, X	dBm/3.84 MHz	-50		-86		-94	
	Band IX*				-85		-93	
	Band II, V, VII, XI				-84		-92	
	Band III, VIII				-83		-91	
Propagation condition		-	AWGN		AWGN		AWGN	
NOTE 1: CPICH Ec/Io and Io levels have been calculated from other parameters for information purposes. They are not settable parameters themselves.								
*) For the UE which supports both Band III and Band IX operating frequencies, the measurement performance requirements for Band III shall apply to the multi-band UE.								
Tests shall be done sequentially. Test 1 shall be done first. After test 1 has been executed test parameters for tests 2 and 3 shall be set within 5 seconds so that UE does not loose the Cell 2 in between the tests.								

8.7.2.1.1.4.2 Procedure

- 1) A call is set up according to the test procedure specified in TS 34.108 [3] subclause 7.3.2. The RF parameters for Test 1 are set up according to table 8.7.2.1.1.5.
- 2) SS shall transmit MEASUREMENT CONTROL message.
- 3) UE shall transmit periodically MEASUREMENT REPORT messages.
- 4) SS shall check CPICH_Ec/Io value in MEASUREMENT REPORT messages. According to table 8.7.2.1.1.3 the SS calculates CPICH_Ec/Io power ratio of Cell 1, which is compared to the actual CPICH Ec/Io power ratio from the same cell for each MEASUREMENT REPORT message.
- 5) SS shall count number of MEASUREMENT REPORT messages transmitted by UE. After 1000 MEASUREMENT REPORT messages have been received from UE, the RF parameters are set up according to table 8.7.2.1.1.5 for Test 2. While RF parameters are being set up, MEASUREMENT REPORT messages from UE are ignored. SS shall wait for additional 1s and ignore the MEASUREMENT REPORT messages during this period. Then, step 4) above is repeated. After further 1000 MEASUREMENT REPORT messages have been received from UE, the RF parameters are set up according to table 8.7.2.1.1.5 for Test 3. While RF parameters are being set up, MEASUREMENT REPORT messages from UE are ignored. SS shall wait for additional 1s and ignore the MEASUREMENT REPORT messages during this period. Then, step 4) above is repeated.
- 6) After further 1000 MEASUREMENT REPORT messages have been received from UE, the SS shall transmit RRC CONNECTION RELEASE message.
- 7) UE shall transmit RRC CONNECTION RELEASE COMPLETE message.

Table 8.7.2.1.1.3: CPICH Ec/Io measurement report mapping

Reported value	Measured quantity value	Unit
CPICH_Ec/No_00	$\text{CPICH Ec/Io} < -24$	dB
CPICH_Ec/No_01	$-24 \leq \text{CPICH Ec/Io} < -23.5$	dB
CPICH_Ec/No_02	$-23.5 \leq \text{CPICH Ec/Io} < -23$	dB
...
CPICH_Ec/No_47	$-1 \leq \text{CPICH Ec/Io} < -0.5$	dB
CPICH_Ec/No_48	$-0.5 \leq \text{CPICH Ec/Io} < 0$	dB
CPICH_Ec/No_49	$0 \leq \text{CPICH Ec/Io}$	dB

Specific Message Contents

All messages indicated above shall use the same content as described in default message content in clause 9 of 34.108 [3], with the following exceptions:

MEASUREMENT CONTROL message for Intra frequency measurement (Step 1):

Information Element	Value/Remark
Message Type	
UE information elements	
-RRC transaction identifier	0
-Integrity check info	
-message authentication code	SS calculates the value of MAC-I for this message and writes to this IE. The first/leftmost bit of the bit string contains the most significant bit of the MAC-I.
-RRC message sequence number	SS provides the value of this IE, from its internal counter.
Measurement Information elements	
-Measurement Identity	1
-Measurement Command	Modify
-Measurement Reporting Mode	
- Measurement Report Transfer Mode	Acknowledged mode RLC
- Periodical Reporting / Event Trigger Reporting Mode	Periodical reporting
-Additional measurement list	Not Present
-CHOICE Measurement Type	Intra-frequency measurement
-Intra-frequency measurement	
- Intra-frequency measurement objects list	Not Present
-Intra-frequency measurement quantity	
-Filter coefficient	0
-CHOICE mode	FDD
-Measurement quantity	CPICH RSCP
-Intra-frequency reporting quantity	
-Reporting quantities for active set cells	
-Cell synchronisation information reporting indicator	TRUE
-Cell Identity reporting indicator	TRUE
-CHOICE mode	FDD
-CPICH Ec/N0 reporting indicator	TRUE
-CPICH RSCP reporting indicator	TRUE
-Pathloss reporting indicator	FALSE
-Reporting quantities for monitored set cells	
-Cell synchronisation information reporting indicator	FALSE
-Cell Identity reporting indicator	FALSE
-CHOICE mode	FDD
-CPICH Ec/N0 reporting indicator	TRUE
-CPICH RSCP reporting indicator	TRUE
-Pathloss reporting indicator	FALSE
-Reporting quantities for detected set cells	Not Present
-Reporting cell status	
-CHOICE reported cell	Report all active set cells + cells within monitored set on used frequency
-Maximum number of reported cells	Virtual/active set cells + 2
-Measurement validity	Not Present
-CHOICE <i>report criteria</i>	Periodical reporting criteria
-Amount of reporting	Infinity
-Reporting interval	250 ms
Physical channel information elements	
-DPCH compressed mode status info	Not Present

MEASUREMENT REPORT message for Intra frequency test cases

This message is common for all intra frequency test cases in clause 8.7 and is described in Annex I.

8.7.2.1.1.5 Test requirements

The CPICH Ec/Io measurement accuracy shall meet the requirements in clause 8.7.2.1.1.2. The effect of assumed thermal noise and noise generated in the receiver (-99 dBm for Band I, IV, VI and X, -98dBm for Band IX, -97 dBm for Band II, V and XI, -96 dBm for Band III) shall be added into the required accuracy defined in subclause 8.7.2.1.1.2 as shown in table 8.7.2.1.1.4.

Table 8.7.2.1.1.4: CPICH_Ec/Io Intra frequency absolute accuracy, test requirements

Parameter	Unit	Accuracy [dB]		Conditions			
		Normal condition	Extreme condition	Io [dBm/3.84 MHz]			
				Band I, IV, VI and X	Band IX	Band II,V, VII and XI	Band III and VIII
CPICH_Ec /Io	dB	-3.1...1.9 for $-14 \leq \text{CPICH Ec/Io}$ -3.6...2.4 for $-16 \leq \text{CPICH Ec/Io} < -14$ -4.6...3.4 for $-20 \leq \text{CPICH Ec/Io} < -16$	-4.6...3.4	-94...-87	-93...-86	-92...-85	-91...-84
		± 1.95 for $-14 \leq \text{CPICH Ec/Io}$ ± 2.4 for $-16 \leq \text{CPICH Ec/Io} < -14$ ± 3.4 for $-20 \leq \text{CPICH Ec/Io} < -16$	± 3.4	-87...-50	-86...-50	-85...-50	-84...-50

The normative reference for this requirement is TS 25.133 [2] clause A.9.1.2.2.

Table 8.7.2.1.1.5: CPICH_Ec/Io Intra frequency tests parameters

Parameter	Unit	Test 1		Test 2		Test 3	
		Cell 1	Cell 2	Cell 1	Cell 2	Cell 1	Cell 2
UTRA RF Channel number		Channel 1		Channel 1		Channel 1	
CPICH_Ec/Ior	dB	-9.7		-9.8		-9.9	
PCCPCH_Ec/Ior	dB	-11.7		-11.8		-11.9	
SCH_Ec/Ior	dB	-11.7		-11.8		-11.9	
PICH_Ec/Ior	dB	-14.7		-14.8		-14.9	
DPCH_Ec/Ior	dB	-14.7	-	-14.8	-	-5.9	-
OCNS_Ec/Ior	dB	-1.2	-1.02	-1.17	-0.99	-2.64	-0.97
Ior	Band I, IV, VI, X	dBm/ 3.84 MHz	-58.5	-89.07		-93.98	
	Band IX*			-88.07		-92.98	
	Band II, V, VII, XI			-87.07		-91.98	
	Band III, VIII			-86.07		-90.98	
Ior/Ioc	dB	3.3	3.3	-2.6	-2.6	-8.7	-8.7
CPICH Ec/Io, Note 1	dBm	-13.6	-13.6	-15.6	-15.6	-19.6	-19.6
Io, Note 1	Band I, IV, VI, X	dBm / 3.84 MHz	-51.3	-85.85		-92.9	
	Band IX*			-84.85		-91.9	
	Band II, V, VII, XI			-83.85		-90.9	
	Band III, VIII			-82.85		-89.9	
Propagation condition	-	AWGN		AWGN		AWGN	
NOTE 1: CPICH Ec/Io and Io levels have been calculated from other parameters for information purposes. They are not settable parameters themselves.							
*) For the UE which supports both Band III and Band IX operating frequencies, the measurement performance requirements for Band III shall apply to the multi-band UE.							
Tests shall be done sequentially. Test 1 shall be done first. After test 1 has been executed test parameters for tests 2 and 3 shall be set within 5 seconds so that UE does not loose the Cell 2 in between the tests.							

The reported values for the absolute intra frequency CPICH Ec/Io measurement shall meet the requirements in table 8.7.2.1.1.6.

Table 8.7.2.1.1.6: CPICH_Ec/Io Intra frequency absolute accuracy requirements for the reported values

	Test 1	Test 2	Test 3
Normal Conditions			
Lowest reported value	CPICH_Ec/No_17	CPICH_Ec/No_12	CPICH_Ec/No_0
Highest reported value	CPICH_Ec/No_25	CPICH_Ec/No_22	CPICH_Ec/No_16
Extreme Conditions			
Lowest reported value	CPICH_Ec/No_14	CPICH_Ec/No_10	CPICH_Ec/No_0
Highest reported value	CPICH_Ec/No_28	CPICH_Ec/No_24	CPICH_Ec/No_16

NOTE: If the above Test Requirement differs from the Minimum Requirement then the Test Tolerance applied for this test is non-zero. The Test Tolerance for this test is defined in clause F.2 and the explanation of how the Minimum Requirement has been relaxed by the Test Tolerance is given in clause F.4.

8.7.2.1.2 Relative accuracy requirement

8.7.2.1.2.1 Definition and applicability

The relative accuracy of CPICH Ec/Io is defined as the CPICH Ec/Io measured from one cell compared to the CPICH Ec/Io measured from another cell on the same frequency.

The requirements and this test apply to all types of UTRA for the FDD UE.

8.7.2.1.2.2 Minimum Requirements

The accuracy requirements in table 8.7.2.1.2.1 are valid under the following conditions:

CPICH_RSCP1,2|_{dBm} ≥ -114 dBm for Bands I, IV, VI and X,

CPICH_RSCP1,2|_{dBm} ≥ -113 dBm for Band IX,

CPICH_RSCP1,2|_{dBm} ≥ -112 dBm for Bands II, V, VII and XI,

CPICH_RSCP1,2|_{dBm} ≥ -111 dBm for Band III and VIII.

$$\left| CPICH_RSCP1 \Big|_{in\ dBm} - CPICH_RSCP2 \Big|_{in\ dBm} \right| \leq 20dB$$

$$\left(\frac{I_o}{\hat{I}_{or}} \right) \Big|_{in\ dB} - \left(\frac{CPICH_E_c}{I_{or}} \right) \Big|_{in\ dB} \leq 20dB$$

Table 8.7.2.1.2.1: CPICH_Ec/Io Intra frequency relative accuracy

Parameter	Unit	Accuracy [dB]		Conditions			
		Normal condition	Extreme condition	Band I, IV, VI and X	Band IX	Band II, V, VII, and XI	Band III and VIII
				Io [dBm/3.84 MHz]	Io [dBm/3.84 MHz]	Io [dBm/3.84 MHz]	Io [dBm/3.84 MHz]
The lower of the CPICH_Ec/Io from cell1 and cell2	dB	± 1.5 for -14 ≤ CPICH Ec/Io ± 2 for -16 ≤ CPICH Ec/Io < -14 ± 3 for -20 ≤ CPICH Ec/Io < -16	± 3	-94...-50	-93...-50	-92...-50	-91...-50

The normative reference for this requirement is TS 25.133 [2] clauses 9.1.2.1.2 and A.9.1.2.2.

8.7.2.1.2.3 Test purpose

The purpose of this test is to verify that the CPICH Ec/Io relative measurement accuracy is within the specified limits in clause 8.7.2.1.2.2. This measurement is for Cell selection/re-selection and for handover evaluation.

8.7.2.1.2.4 Method of test

8.7.2.1.2.4.1 Initial conditions

Test environment: normal, TL/VL, TL/VH, TH/VL, TH/VH; see clauses G.2.1 and G.2.2.

Frequencies to be tested: mid range; see clause G.2.4.

In this case all cells are in the same frequency. CPICH Ec/Io intra frequency relative accuracy requirements are tested by using test parameters in table 8.7.2.1.1.2.

8.7.2.1.2.4.2 Procedure

- 1) A call is set up according to the test procedure specified in TS 34.108 [3] subclause 7.3.2. The RF parameters for Test 1 are set up according to table 8.7.2.1.2.3.
- 2) SS shall transmit MEASUREMENT CONTROL message.
- 3) UE shall transmit periodically MEASUREMENT REPORT messages.
- 4) SS shall check CPICH_Ec/No value of Cell 1 and Cell 2 in MEASUREMENT REPORT messages. According to table 8.7.2.1.1.3 the SS calculates CPICH_Ec/Io power ratio of Cell 1 and Cell 2. CPICH_Ec/Io power ratio value measured from Cell 1 is compared to CPICH_Ec/Io power ratio value measured from Cell 2 for each MEASUREMENT REPORT message.
- 5) The result of step 3) is compared to actual power level difference of CPICH_Ec/Io of Cell 1 and Cell 2.
- 6) SS shall count number of MEASUREMENT REPORT messages transmitted by UE. After 1000 MEASUREMENT REPORT messages have been received from UE, the RF parameters are set up according to table 8.7.2.1.2.3 for Test 2. While RF parameters are being set up, MEASUREMENT REPORT messages from UE are ignored. SS shall wait for additional 1s and ignore the MEASUREMENT REPORT messages during this period. Then, steps 4) and 5) above are repeated. After further 1000 MEASUREMENT REPORT messages have been received from UE, the RF parameters are set up according to table 8.7.2.1.2.3 for Test 3. While RF parameters are being set up, MEASUREMENT REPORT messages from UE are ignored. SS shall wait for additional 1s and ignore the MEASUREMENT REPORT messages during this period. Then, steps 4) and 5) above are repeated.
- 7) After further 1000 MEASUREMENT REPORT messages have been received from UE, the SS shall transmit RRC CONNECTION RELEASE message.
- 8) UE shall transmit RRC CONNECTION RELEASE COMPLETE message.

Specific Message Contents

All messages indicated above shall use the same content as described in the default message content in clause 9 of 34.108 [3], with the following exceptions:

MEASUREMENT CONTROL message for Intra frequency measurement in clause 8.7.2.1.1.4.2 is used.

MEASUREMENT REPORT message for Intra frequency test cases

This message is common for all intra frequency test cases in clause 8.7 and is described in Annex I.

8.7.2.1.2.5 Test requirements

Table 8.7.2.1.2.2: CPICH_Ec/Io Intra frequency relative accuracy

Parameter	Unit	Accuracy [dB]		Conditions			
		Normal condition	Extreme condition	Io [dBm / 3.84 MHz]			
				Band I, IV, VI, and X	Band IX	Band II, V, VII and XI	Band III and VIII
CPICH_Ec/Io	dB	± 2.3 for $-14 \leq \text{CPICH Ec/Io}$ ± 2.8 for $-16 \leq \text{CPICH Ec/Io} < -14$ ± 3.8 for $-20 \leq \text{CPICH Ec/Io} < -16$	± 3.8	-94...-50	-93...-50	-92...-50	-91...-50

Table 8.7.2.1.2.3: CPICH_Ec/Io Intra frequency tests parameters

Parameter		Unit	Test 1		Test 2		Test 3	
			Cell 1	Cell 2	Cell 1	Cell 2	Cell 1	Cell 2
UTRA RF Channel number			Channel 1		Channel 1		Channel 1	
CPICH_Ec/Io		dB	-9.7		-9.8		-9.9	
PCCPCH_Ec/Io		dB	-11.7		-11.8		-11.9	
SCH_Ec/Io		dB	-11.7		-11.8		-11.9	
PICH_Ec/Io		dB	-14.7		-14.8		-14.9	
DPCH_Ec/Io		dB	-14.7	-	-14.8	-	-5.9	-
OCNS_Ec/Io		dB	-1.2	-1.02	-1.17	-0.99	-2.64	-0.97
Ioc	Band I, IV, VI, X	dBm/ 3.84 MHz	-58.5		-89.07		-93.98	
	Band IX*				-88.07		-92.98	
	Band II, V, VII, XI				-87.07		-91.98	
	Band III, VIII				-86.07		-90.98	
Ior/Ioc	dB	3.3	3.3	-2.6	-2.6	-8.7	-8.7	
CPICH Ec/Io, Note 1		dBm	-13.6	-13.6	-15.6	-15.6	-19.6	-19.6
Io, Note 1	Band I, IV, VI, X	dBm / 3.84 MHz	-51,3		-85.85		-92.9	
	Band IX*				-84.85		-91.9	
	Band II, V, VII, XI				-83.85		-90.9	
	Band III, VIII				-82.85		-89.9	
Propagation condition		-	AWGN		AWGN		AWGN	
NOTE 1: CPICH Ec/Io and Io levels have been calculated from other parameters for information purposes. They are not settable parameters themselves.								
*) For the UE which supports both Band III and Band IX operating frequencies, the measurement performance requirements for Band III shall apply to the multi-band UE.								
Tests shall be done sequentially. Test 1 shall be done first. After test 1 has been executed test parameters for tests 2 and 3 shall be set within 5 seconds so that UE does not loose the Cell 2 in between the tests.								

The reported values for the relative intra frequency CPICH Ec/Io measurement shall meet the requirements in table 8.7.2.1.2.4.

Table 8.7.2.1.2.4: CPICH_Ec/Io Intra frequency relative accuracy requirements for the reported values

	Test 1	Test 2	Test 3
Normal Conditions			
Lowest reported value cell 2	CPICH_Ec/No_(x - 5)	CPICH_Ec/No_(x - 6)	CPICH_Ec/No_(x - 8)
Highest reported value cell 2	CPICH_Ec/No_(x+ 5)	CPICH_Ec/No_(x + 6)	CPICH_Ec/No_(x+ 8)
Extreme Conditions			
Lowest reported value cell2	CPICH_Ec/No_(x - 8)	CPICH_Ec/No_(x - 8)	CPICH_Ec/No_(x - 8)
Highest reported value cell2	CPICH_Ec/No_(x + 8)	CPICH_Ec/No_(x+ 8)	CPICH_Ec/No_(x+ 8)
CPICH_Ec/No_x is the reported value of cell 1			

NOTE: If the above Test Requirement differs from the Minimum Requirement then the Test Tolerance applied for this test is non-zero. The Test Tolerance for this test is defined in clause F.2 and the explanation of how the Minimum Requirement has been relaxed by the Test Tolerance is given in clause F.4.

8.7.2.2 Inter frequency measurement accuracy

8.7.2.2.1 Absolute accuracy requirement

Void

8.7.2.2.2 Relative accuracy requirement

8.7.2.2.2.1 Definition and applicability

The relative accuracy of CPICH Ec/Io in the inter frequency case is defined as the CPICH Ec/Io measured from one cell compared to the CPICH Ec/Io measured from another cell on a different frequency.

The requirements and this test apply to all types of UTRA for the FDD UE.

8.7.2.2.2.2 Minimum Requirements

The accuracy requirements in table 8.7.2.2.2.1 are valid under the following conditions:

$CPICH_RSCP1,2|_{dBm} \geq -114$ dBm for Bands I, IV, VI and X,

$CPICH_RSCP1,2|_{dBm} \geq -113$ dBm for Band IX,

$CPICH_RSCP1,2|_{dBm} \geq -112$ dBm for Bands II, V, VII and XI,

$CPICH_RSCP1,2|_{dBm} \geq -111$ dBm for Band III and VIII.

$$\left| CPICH_RSCP1|_{in\ dBm} - CPICH_RSCP2|_{in\ dBm} \right| \leq 20\ dB$$

$$| Channel\ 1_Io|_{dBm/3.84\ MHz} - Channel\ 2_Io|_{dBm/3.84\ MHz} | \leq 20\ dB.$$

$$\left(\frac{I_o}{\hat{I}_{or}} \right)_{in\ dB} - \left(\frac{CPICH_E_c}{I_{or}} \right)_{in\ dB} \leq 20\ dB$$

Table 8.7.2.2.2.1: CPICH_Ec/Io Inter frequency relative accuracy, minimum requirements

Parameter	Unit	Accuracy [dB]		Conditions			
		Normal condition	Extreme condition	Band I, IV, VI, and X	Band IX	Band II, V, VII and XI	Band III and VIII
				Io [dBm/3.84 MHz]	Io [dBm/3.84 MHz]	Io [dBm/3.84 MHz]	Io [dBm/3.84 MHz]
The lower of the CPICH_Ec/Io from cell1 and cell2	dB	± 1.5 for $-14 \leq CPICH\ Ec/Io$ ± 2 for $-16 \leq CPICH\ Ec/Io < -14$ ± 3 for $-20 \leq CPICH\ Ec/Io < -16$	± 3	-94...-50	-93...-50	-92...-50	-91...-50

The normative reference for this requirement is TS 25.133 [2] clauses 9.1.2.2.2 and A.9.1.2.2.

8.7.2.2.2.3 Test purpose

The purpose of this test is to verify that the CPICH Ec/Io relative measurement accuracy is within the specified limits in clause 8.7.2.2.2.2. This measurement is for Cell selection/re-selection and for handover evaluation.

8.7.2.2.2.4 Method of test

8.7.2.2.2.4.1 Initial conditions

Test environment: normal, TL/VL, TL/VH, TH/VL, TH/VH; see clauses G.2.1 and G.2.2.

Frequencies to be tested: mid range; see clause G.2.4.

In this case both cells are in different frequency and compressed mode is applied. The gap length is 7, detailed definition is in clause C.5, set 1 of table C.5.2 except for TGRRC and TGCFN. TGPRC and TGCFN shall set to "Infinity" and "(Current CFN + (256 – TTI/10msec))mod 256". CPICH Ec/Io inter frequency relative accuracy requirements are tested by using test parameters in table 8.7.2.2.2.2.

Table 8.7.2.2.2.2: CPICH Ec/Io Inter frequency parameters

Parameter	Unit	Test 1		Test 2		Test 3		
		Cell 1	Cell 2	Cell 1	Cell 2	Cell 1	Cell 2	
UTRA RF Channel number		Channel 1	Channel 2	Channel 1	Channel 2	Channel 1	Channel 2	
CPICH_Ec/Ior	dB	-10		-10		-10		
PCCPCH_Ec/Ior	dB	-12		-12		-12		
SCH_Ec/Ior	dB	-12		-12		-12		
PICH_Ec/Ior	dB	-15		-15		-15		
DPCH_Ec/Ior	dB	-15	-	-6	-	-6	-	
OCNS_Ec/Ior	dB	-1.11	-0.94	-2.56	-0.94	-2.56	-0.94	
Ior	Band I, IV, VI, X	dBm/ 3.84 MHz	-52.22	-52.22	-87.27	-87.27	-94.46	-94.46
	Band IX*				-86.27	-86.27	-93.46	-93.46
	Band II, V, VII, XI				-85.27	-85.27	-92.46	-92.46
	Band III, VIII				-84.27	-84.27	-91.46	-91.46
Ior/Ioc	dB	-1.75	-1.75	-4.7	-4.7	-9.54	-9.54	
CPICH Ec/Io, Note 1	dBm	-14.0	-14.0	-16.0	-16.0	-20.0	-20.0	
Io, Note 1	Band I, IV, VI, X	dBm/3.84 MHz	-50	-50	-86	-86	-94	-94
	Band IX*				-85	-85	-93	-93
	Band II, V, VII, XI				-84	-84	-92	-92
	Band III, VIII				-83	-83	-91	-91
Propagation condition	-	AWGN		AWGN		AWGN		
NOTE 1: CPICH Ec/Io and Io levels have been calculated from other parameters for information purposes. They are not settable parameters themselves.								
*) For the UE which supports both Band III and Band IX operating frequencies, the measurement performance requirements for Band III shall apply to the multi-band UE.								
Tests shall be done sequentially. Test 1 shall be done first. After test 1 has been executed test parameters for tests 2 and 3 shall be set within 5 seconds so that UE does not loose the Cell 2 in between the tests.								

8.7.2.2.2.4.2 Procedure

- 1) A call is set up according to the test procedure specified in TS 34.108 [3] subclause 7.3.2. The RF parameters for Test 1 are set up according to table 8.7.2.2.2.4.
- 2) SS shall transmit PHYSICAL CHANNEL RECONFIGURATION message.
- 3) UE shall transmit PHYSICAL CHANNEL RECONFIGURATION COMPLETE message.
- 4) SS shall transmit a MEASUREMENT CONTROL message for intra frequency measurement and transmit another MEASUREMENT CONTROL message for inter frequency measurement.
- 5) UE shall transmit periodically MEASUREMENT REPORT messages.
- 6) SS shall check CPICH_Ec/Io value of Cell 1 and Cell 2 in MEASUREMENT REPORT messages. According to table 8.7.2.1.1.3 the SS calculates CPICH_Ec/Io power ratio of Cell 1 and Cell 2. CPICH_Ec/Io power ratio measured from Cell 1 is compared to CPICH_Ec/Io power value measured from Cell 2 for each MEASUREMENT REPORT message.
- 7) The result of step 6) is compared to actual power level difference of CPICH_Ec/Io of Cell 1 and Cell 2.
- 8) SS shall count number of MEASUREMENT REPORT messages transmitted by UE. After 1000 MEASUREMENT REPORT messages have been received from UE, the RF parameters are set up according to table 8.7.2.2.2.4 for Test 2. While RF parameters are being set up, MEASUREMENT REPORT messages from UE are ignored. SS shall wait for additional 1s and ignore the MEASUREMENT REPORT messages during this period. Then, steps 6) and 7) above are repeated. After further 1000 MEASUREMENT REPORT messages have been received from UE, the RF parameters are set up according to table 8.7.2.2.2.4 for Test 3. While RF parameters are being set up, MEASUREMENT REPORT messages from UE are ignored. SS shall wait for additional 1s and ignore the MEASUREMENT REPORT messages during this period. Then, steps 6) and 7) above are repeated.
- 9) After 1000 MEASUREMENT REPORT messages have been received from UE, the SS shall transmit RRC CONNECTION RELEASE message.
- 10) UE shall transmit RRC CONNECTION RELEASE COMPLETE message.

Specific Message Contents

All messages indicated above shall use the same content as described in default message content in clause 9 of 34.108 [3], with the following exceptions:

PHYSICAL CHANNEL RECONFIGURATION message for Inter frequency measurement (step 1):

Information Element	Value/Remark	Version
Message Type		
UE Information Elements		
-RRC transaction identifier	0	
-Integrity check info		
-message authentication code	SS calculates the value of MAC-I for this message and writes to this IE. The first/ leftmost bit of the bit string contains the most significant bit of the MAC-I.	
-RRC message sequence number	SS provides the value of this IE, from its internal counter.	
-Integrity protection mode info	Not Present	
-Ciphering mode info	Not Present	
-Activation time	Not Present	
-New U-RNTI	Not Present	
-New C-RNTI	Not Present	
-RRC State Indicator	CELL_DCH	
-UTRAN DRX cycle length coefficient	Not Present	
CN Information Elements		
-CN Information info	Not Present	
UTRAN mobility information elements		
-URA identity	Not Present	
RB information elements		
-Downlink counter synchronisation info	Not Present	
PhyCH information elements		
-Frequency info	Not Present	
Uplink radio resources		
-Maximum allowed UL TX power	Not Present	
- CHOICE channel requirement	Not Present	
Downlink radio resources		
-CHOICE mode	FDD	
-Downlink PDSCH information	Not Present	R99 and Rel-4 only
-Downlink information common for all radio links		
-Downlink DPCH info common for all RL	Not Present	
-CHOICE mode	FDD	
-DPCH compressed mode info		
-Transmission gap pattern sequence		
-TGPSI	1	
-TGPS Status Flag	Activate	
-TGCFN	(Current CFN + (256 – TTI/10msec))mod 256	
-Transmission gap pattern sequence		
configuration parameters		
-TGMP	FDD measurement	
-TGPRC	Infinity	
-TGSN	4	
-TGL1	7	
-TGL2	Not Present	
-TGD	UNDEFINED	
-TGPL1	3	
-TGPL2	Not Present	R99 and Rel-4 only
-RPP	Mode 0	
-ITP	Mode 0	
-CHOICE UL/DL mode	UL and DL	
-Downlink compressed mode method	SF/2	
-Uplink compressed mode method	SF/2	
-Downlink frame type	B	
-DeltaSIR1	3.0	
-DeltaSIRafter1	3.0	
-DeltaSIR2	Not Present	
-DeltaSIRafter2	Not Present	
-N Identify abort	Not Present	
-T Reconfirm abort	Not Present	
-TX Diversity Mode	Not Present	
-SSDT information	Not Present	R99 and Rel-4 only

-Default DPCH Offset Value	Not Present	
-Downlink information per radio link list		
-Downlink information for each radio link		
-Choice mode	FDD	
-Primary CPICH info		
-Primary scrambling code	100	
-PDSCH with SHO DCH Info	Not Present	R99 and Rel-4 only
-PDSCH code mapping	Not Present	R99 and Rel-4 only
-Downlink DPCH info for each RL		
-CHOICE mode	FDD	
-Primary CPICH usage for channel estimation	Primary CPICH may be used	
-DPCH frame offset	Set to value Default DPCH Offset Value (as currently stored in SS) mod 38400	
-Secondary CPICH info	Not Present	
-DL channelisation code		
-Secondary scrambling code	Not Present	
-Spreading factor	128	
-Code number	96	
-Scrambling code change	No code change	
-TPC combination index	0	
-SSDT Cell Identity	Not Present	R99 and Rel-4 only
-Closed loop timing adjustment mode	Not Present	
-SCCPCH Information for FACH	Not Present	

First MEASUREMENT CONTROL message for Intra frequency measurement (Step 3):

Information Element	Value/Remark
Message Type	
UE information elements	
-RRC transaction identifier	0
-Integrity check info	
-message authentication code	SS calculates the value of MAC-I for this message and writes to this IE. The first/leftmost bit of the bit string contains the most significant bit of the MAC-I.
-RRC message sequence number	SS provides the value of this IE, from its internal counter.
Measurement Information elements	
-Measurement Identity	1
-Measurement Command	Modify
-Measurement Reporting Mode	
- Measurement Report Transfer Mode	Acknowledged mode RLC
- Periodical Reporting / Event Trigger Reporting Mode	Periodical reporting
-Additional measurement list	Not Present
-CHOICE Measurement Type	Intra-frequency measurement
-Intra-frequency measurement	
- Intra-frequency measurement objects list	
-Intra-frequency cell info list	Not Present
-Intra-frequency measurement quantity	
-Filter coefficient	0
-CHOICE mode	FDD
-Measurement quantity	CPICH RSCP
-Intra-frequency reporting quantity	
-Reporting quantities for active set cells	
-Cell synchronisation information reporting indicator	TRUE
-Cell Identity reporting indicator	TRUE
-CHOICE mode	FDD
-CPICH Ec/N0 reporting indicator	TRUE
-CPICH RSCP reporting indicator	TRUE
-Pathloss reporting indicator	FALSE
-Reporting quantities for monitored set cells	
-Cell synchronisation information reporting indicator	FALSE
-Cell Identity reporting indicator	TRUE
-CHOICE mode	FDD
-CPICH Ec/N0 reporting indicator	TRUE
-CPICH RSCP reporting indicator	TRUE
-Pathloss reporting indicator	FALSE
-Reporting quantities for detected set cells	Not Present
-Reporting cell status	
-CHOICE reported cell	Report all active set cells + cells within monitored set on used frequency
-Maximum number of reported cells	Virtual/active set cells + 2
-Measurement validity	Not Present
-CHOICE <i>report criteria</i>	Periodical reporting criteria
-Amount of reporting	Infinity
-Reporting interval	250 ms
Physical channel information elements	
-DPCH compressed mode status info	Not Present

Second MEASUREMENT CONTROL message for Inter frequency measurement (step 3):

Information Element	Value/Remark
Message Type	
UE information elements	
-RRC transaction identifier	0
-Integrity check info	
-message authentication code	SS calculates the value of MAC-I for this message and writes to this IE. The first/leftmost bit of the bit string contains the most significant bit of the MAC-I.
-RRC message sequence number	SS provides the value of this IE, from its internal counter.
Measurement Information elements	
-Measurement Identity	2
-Measurement Command	Setup
-Measurement Reporting Mode	
- Measurement Report Transfer Mode	Acknowledged mode RLC
- Periodical Reporting / Event Trigger Reporting Mode	Periodical reporting
-Additional measurement list	Not Present
-CHOICE Measurement Type	Inter-frequency measurement
-Inter-frequency measurement	
-Inter-frequency cell info list	
-CHOICE Inter-frequency cell removal	Not Present
-New inter-frequency cells	Cell 2 information is included
-Cell for measurement	Not Present
-Inter-frequency measurement quantity	
-CHOICE reporting criteria	Inter-frequency reporting criteria
-Filter coefficient	0
-CHOICE mode	FDD
-Measurement quantity for frequency quality estimate	CPICH RSCP
-Inter-frequency reporting quantity	
-UTRA Carrier RSSI	TRUE
-Frequency quality estimate	TRUE
-Non frequency related cell reporting quantities	
-Cell synchronisation information reporting indicator	TRUE
-Cell Identity reporting indicator	TRUE
-CHOICE mode	FDD
-CPICH Ec/N0 reporting indicator	TRUE
-CPICH RSCP reporting indicator	TRUE
-Pathloss reporting indicator	FALSE
-Reporting cell status	
-CHOICE reported cell	Report cells within monitored set on non-used frequency
-Maximum number of reported cells	2
-Measurement validity	Not Present
-Inter-frequency set update	Not Present
-CHOICE report criteria	Periodical reporting criteria
-Amount of reporting	Infinity
-Reporting interval	500 ms
Physical channel information elements	
-DPCH compressed mode status info	Not Present

MEASUREMENT REPORT message for Intra frequency test cases

This message is common for all inter frequency test cases in clause 8.7 and is described in Annex I.

8.7.2.2.2.5 Test requirements

The effect of assumed thermal noise and noise generated in the receiver (-99 dBm for Band I, IV, VI and X, -98dBm for Band IX, -97 dBm for Band II, V and XI, -96 dBm for Band III) shall be added into the required accuracy defined in clause 8.7.2.2.2.2 as shown in table 8.7.2.2.2.3.

Table 8.7.2.2.3: CPICH_Ec/Io Inter frequency relative accuracy, test requirements

Parameter	Unit	Normal condition	Extreme condition	Io [dBm/3.84 MHz]			
				Band I, IV, VI and X	Band IX	Band II, V, VII and XI	Band III and VIII
CPICH_Ec/Io	dB	±3.5 for -14 ≤ CPICH Ec/Io ±4 for -16 ≤ CPICH Ec/Io < -14 ±5 for -20 ≤ CPICH Ec/Io < -16	± 5	-94...-87	-93...-86	-92...-85	-91...-84
		±2.3 for -14 ≤ CPICH Ec/Io ± 2.8 for -16 ≤ CPICH Ec/Io < -14 ± 3.8 for -20 ≤ CPICH Ec/Io < -16	± 3.8	-87...-50	-86...-50	-85...-50	-84...-50

The normative reference for this requirement is TS 25.133 [2] clause A.9.1.2.2.

Table 8.7.2.2.4: CPICH Ec/Io Inter frequency tests parameters

Parameter		Unit	Test 1		Test 2		Test 3	
			Cell 1	Cell 2	Cell 1	Cell 2	Cell 1	Cell 2
UTRA RF Channel number			Channel 1	Channel 2	Channel 1	Channel 2	Channel 1	Channel 2
CPICH_Ec/Ior		dB	-10		-10		-10	
PCCPCH_Ec/Ior		dB	-12		-12		-12	
SCH_Ec/Ior		dB	-12		-12		-12	
PICH_Ec/Ior		dB	-15		-15		-15	
DPCH_Ec/Ior		dB	-15	-	-6	-	-6	-
OCNS_Ec/Ior		dB	-1.11	-0.94	-2.56	-0.94	-2.56	-0.94
Ior	Band I, IV, VI, X	dBm/ 3.84 MHz	-53.5	-53.5	-86.27	-86.27	-93.46	-93.46
	Band IX*				-85.27	-85.27	-92.46	-92.46
	Band II, V, VII, XI				-84.27	-84.27	-91.46	-91.46
	Band III, VIII				-83.27	-83.27	-90.46	-90.46
Ior/Ioc		dB	-1.45	-1.45	-4.4	-4.4	-9.24	-9.24
CPICH Ec/Io, Note 1		dBm	-13.8	-13.8	-15.7	-15.7	-19.7	-19.7
Io, Note 1	Band I, IV, VI, X	dBm /3.84 MHz	-51.15	-51.15	-84.9	-84.9	-93	-93
	Band IX*				-83.9	-83.9	-92	-92
	Band II, V, VII, XI				-82.9	-82.9	-91	-91
	Band III, VIII				-81.9	-81.9	-90	-90
Propagation condition		-	AWGN		AWGN		AWGN	
NOTE 1: CPICH Ec/Io and Io levels have been calculated from other parameters for information purposes. They are not settable parameters themselves.								
*) For the UE which supports both Band III and Band IX operating frequencies, the measurement performance requirements for Band III shall apply to the multi-band UE.								
Tests shall be done sequentially. Test 1 shall be done first. After test 1 has been executed test parameters for tests 2 and 3 shall be set within 5 seconds so that UE does not loose the Cell 2 in between the tests.								

NOTE: If the above Test Requirement differs from the Minimum Requirement then the Test Tolerance applied for this test is non-zero. The Test Tolerance for this test is defined in clause F.2 and the explanation of how the Minimum Requirement has been relaxed by the Test Tolerance is given in clause F.4.

The reported values for the relative inter frequency CPICH Ec/Io measurement shall meet the requirements in table 8.7.2.2.5.

Table 8.7.2.2.5: CPICH_Ec/Io Inter frequency relative accuracy requirements for the reported values

	Test 1	Test 2	Test 3
Normal Conditions			
Lowest reported value cell 2	CPICH_Ec/No_(x -5)	CPICH_Ec/No_(x - 6)	CPICH_Ec/No_(x - 10)
Highest reported value cell 2	CPICH_Ec/No_(x+5)	CPICH_Ec/No_(x + 6)	CPICH_Ec/No_(x +10)
Extreme Conditions			
Lowest reported value cell2	CPICH_Ec/No_(x - 8)	CPICH_Ec/No_(x - 8)	CPICH_Ec/No_(x - 10)
Highest reported value cell2	CPICH_Ec/No_(x + 8)	CPICH_Ec/No_(x + 8)	CPICH_Ec/No_(x + 10)
CPICH_Ec/No_x is the reported value of cell 1			

8.7.3 UTRA Carrier RSSI

NOTE: This measurement is for Inter-frequency handover evaluation.

8.7.3.1 Absolute measurement accuracy requirement

8.7.3.1.1 Definition and applicability

The absolute accuracy of UTRA Carrier RSSI is defined as the UTRA Carrier RSSI measured from one frequency compared to the actual UTRA Carrier RSSI power of that same frequency.

The requirements and this test apply to all types of UTRA for the FDD UE.

8.7.3.1.2 Minimum Requirements

Table 8.7.3.1.1: UTRA Carrier RSSI Inter frequency absolute accuracy

Parameter	Unit	Accuracy [dB]		Conditions			
		Normal condition	Extreme condition	Band I, IV, VI, and X	Band IX	Band II, V, VII and XI	Band III and VIII
				Io [dBm/3.84 MHz]	Io [dBm/3.84 MHz]	Io [dBm/3.84 MHz]	Io [dBm/3.84 MHz]
UTRA Carrier RSSI	dBm	± 4	± 7	-94...-70	-93...-70	-92...-70	-91...-70
	dBm	± 6	± 9	-70...-50	-70...-50	-70...-50	-70...-50

The normative reference for this requirement is TS 25.133 [2] clause 9.1.3.1.

8.7.3.1.3 Test purpose

The purpose of this test is to verify that the UTRA Carrier RSSI measurement is within the specified limits. This measurement is for inter-frequency handover evaluation.

8.7.3.1.4 Method of test

8.7.3.1.4.1 Initial conditions

Test environment: normal, TL/VL, TL/VH, TH/VL, TH/VH; see clauses G.2.1 and G.2.2.

Frequencies to be tested: mid range; see clause G.2.4.

In this case both cells are on different frequencies and compressed mode is applied. The gap length is 7, detailed definition is in clause C.5, Set 1 of table C.5.2 except for TGRRC and TGCFN. TGPRC and TGCFN shall set to "Infinity" and "(Current CFN + (256 – TTI/10msec))mod 256". UTRA Carrier RSSI absolute accuracy requirements are tested by using test parameters in table 8.7.3.1.2.

Table 8.7.3.1.2: UTRA Carrier RSSI Inter frequency absolute accuracy parameters

Parameter	Unit	Test 1		Test 2		Test 3		
		Cell 1	Cell 2	Cell 1	Cell 2	Cell 1	Cell 2	
UTRA RF Channel number		Channel 1	Channel 2	Channel 1	Channel 2	Channel 1	Channel 2	
CPICH_Ec/lor	dB	-10		-10		-10		
PCCPCH_Ec/lor	dB	-12		-12		-12		
SCH_Ec/lor	dB	-12		-12		-12		
PICH_Ec/lor	dB	-15		-15		-15		
DPCH_Ec/lor	dB	-15	-	-6	-	-6	-	
OCNS_Ec/lor	dB	-1.11	-0.94	-2.56	-0.94	-2.56	-0.94	
lor	Band I, IV, VI, X	dBm/ 3.84 MHz	-52.22	-52.22	-70.27	-70.27	-94.46	-94.46
	Band IX*						-93.46	-93.46
	Band II, V, VII, XI						-92.46	-92.46
	Band III, VIII						-91.46	-91.46
lor/lor	dB	-1.75	-1.75	-4.7	-4.7	-9.54	-9.54	
CPICH Ec/lo, Note 1	dBm	-14.0	-14.0	-16.0	-16.0	-20.0	-20.0	
lo, Note 1	Band I, IV, VI, X	dBm/3.84 MHz	-50	-50	-69	-69	-94	-94
	Band IX*						-93	-93
	Band II, V, VII, XI						-92	-92
	Band III, VIII						-91	-91
Propagation condition	-	AWGN		AWGN		AWGN		
NOTE 1: CPICH Ec/lo and lo levels have been calculated from other parameters for information purposes. They are not settable parameters themselves.								
*) For the UE which supports both Band III and Band IX operating frequencies, the measurement performance requirements for Band III shall apply to the multi-band UE.								
Tests shall be done sequentially. Test 1 shall be done first. After test 1 has been executed test parameters for tests 2 and 3 shall be set within 5 seconds so that UE does not loose the Cell 2 in between the tests.								

8.7.3.1.4.2 Procedure

- 1) A call is set up according to the test procedure specified in TS 34.108 [3] subclause 7.3.2. The RF parameters for Test 1 are set up according to table 8.7.3.1.2.
- 2) SS shall transmit PHYSICAL CHANNEL RECONFIGURATION message.
- 3) UE shall transmit PHYSICAL CHANNEL RECONFIGURATION COMPLETE message.
- 4) SS shall transmit MEASUREMENT CONTROL message.
- 5) UE shall transmit periodically MEASUREMENT REPORT messages.
- 6) SS shall check UTRA carrier RSSI value of Channel 2 in MEASUREMENT REPORT messages. UTRA carrier RSSI power of Channel 2 reported by UE is compared to actual UTRA Carrier RSSI value of Channel 2 for each MEASUREMENT REPORT message.
- 7) SS shall count number of MEASUREMENT REPORT messages transmitted by UE. After 1000 MEASUREMENT REPORT messages have been received from UE, the RF parameters are set up according to table 8.7.3.1.2 for Test 2. While RF parameters are being set up, MEASUREMENT REPORT messages from UE are ignored. SS shall wait for additional 1s and ignore the MEASUREMENT REPORT messages during this period. Then, step 6) above is repeated. After further 1000 MEASUREMENT REPORT messages have been received from UE, the RF parameters are set up according to table 8.7.3.1.2 for Test 3. While RF parameters are being set up, MEASUREMENT REPORT messages from UE are ignored. SS shall wait for additional 1s and ignore the MEASUREMENT REPORT messages during this period. Then, step 6) above is repeated.
- 8) After further 1000 MEASUREMENT REPORT messages have been received from UE, the SS shall transmit RRC CONNECTION RELEASE message.
- 9) UE shall transmit RRC CONNECTION RELEASE COMPLETE message.

Specific Message Contents

All messages indicated above shall use the same content as described in default message content in clause 9 of 34.108 [3], with the following exceptions:

PHYSICAL CHANNEL RECONFIGURATION message for Inter frequency measurement (step 2):

Information Element	Value/Remark	Version
Message Type		
UE Information Elements		
-RRC transaction identifier	0	
-Integrity check info		
-message authentication code	SS calculates the value of MAC-I for this message and writes to this IE. The first/ leftmost bit of the bit string contains the most significant bit of the MAC-I.	
-RRC message sequence number	SS provides the value of this IE, from its internal counter.	
-Integrity protection mode info	Not Present	
-Ciphering mode info	Not Present	
-Activation time	Not Present	
-New U-RNTI	Not Present	
-New C-RNTI	Not Present	
-RRC State Indicator	CELL_DCH	
-UTRAN DRX cycle length coefficient	Not Present	
CN Information Elements		
-CN Information info	Not Present	
UTRAN mobility information elements		
-URA identity	Not Present	
RB information elements		
-Downlink counter synchronisation info	Not Present	
PhyCH information elements		
-Frequency info	Not Present	
Uplink radio resources		
-Maximum allowed UL TX power	Not Present	
- CHOICE channel requirement	Not Present	
Downlink radio resources		
-CHOICE mode	FDD	
-Downlink PDSCH information	Not Present	R99 and Rel-4 only
-Downlink information common for all radio links		
-Downlink DPCH info common for all RL	Not Present	
-CHOICE mode	FDD	
-DPCH compressed mode info		
-Transmission gap pattern sequence		
-TGPSI	1	
-TGPS Status Flag	Activate	
-TGCFN	(Current CFN + (256 – TTI/10msec))mod 256	
-Transmission gap pattern sequence		
configuration parameters		
-TGMP	FDD measurement	
-TGPRC	Infinity	
-TGSN	4	
-TGL1	7	
-TGL2	Not Present	
-TGD	UNDEFINED	
-TGPL1	3	
-TGPL2	Not Present	R99 and Rel-4 only
-RPP	Mode 0	
-ITP	Mode 0	
-CHOICE UL/DL mode	UL and DL	
-Downlink compressed mode method	SF/2	
-Uplink compressed mode method	SF/2	
-Downlink frame type	B	
-DeltaSIR1	3.0	
-DeltaSIRafter1	3.0	
-DeltaSIR2	Not Present	
-DeltaSIRafter2	Not Present	
-N Identify abort	Not Present	
-T Reconfirm abort	Not Present	
-TX Diversity Mode	Not Present	
-SSDT information	Not Present	R99 and Rel-4 only

-Default DPCH Offset Value	Not Present	
-Downlink information per radio link list		
-Downlink information for each radio link		
-Choice mode	FDD	
-Primary CPICH info		
-Primary scrambling code	100	
-PDSCH with SHO DCH Info	Not Present	R99 and Rel-4 only
-PDSCH code mapping	Not Present	R99 and Rel-4 only
-Downlink DPCH info for each RL		
-CHOICE mode	FDD	
-Primary CPICH usage for channel estimation	Primary CPICH may be used	
-DPCH frame offset	Set to value Default DPCH Offset Value (as currently stored in SS) mod 38400	
-Secondary CPICH info	Not Present	
-DL channelisation code		
-Secondary scrambling code	Not Present	
-Spreading factor	128	
-Code number	96	
-Scrambling code change	No code change	
-TPC combination index	0	
-SSDT Cell Identity	Not Present	R99 and Rel-4 only
-Closed loop timing adjustment mode	Not Present	
-SCCPCH Information for FACH	Not Present	

MEASUREMENT CONTROL message for Inter frequency measurement (step 4):

Information Element	Value/Remark
Message Type	
UE information elements	
-RRC transaction identifier	0
-Integrity check info	
-message authentication code	SS calculates the value of MAC-I for this message and writes to this IE. The first/leftmost bit of the bit string contains the most significant bit of the MAC-I.
-RRC message sequence number	SS provides the value of this IE, from its internal counter.
Measurement Information elements	
-Measurement Identity	2
-Measurement Command	Setup
-Measurement Reporting Mode	
- Measurement Report Transfer Mode	Acknowledged mode RLC
- Periodical Reporting / Event Trigger Reporting Mode	Periodical reporting
-Additional measurement list	Not Present
-CHOICE Measurement Type	Inter-frequency measurement
-Inter-frequency measurement	
-Inter-frequency cell info list	
-CHOICE Inter-frequency cell removal	Not Present
-New inter-frequency cells	Cell 2 information is included.
-Cell for measurement	Not Present
-Inter-frequency measurement quantity	
-CHOICE reporting criteria	Inter-frequency reporting criteria
-Filter coefficient	0
-CHOICE mode	FDD
-Measurement quantity for frequency quality estimate	CPICH RSCP
-Inter-frequency reporting quantity	
-UTRA Carrier RSSI	TRUE
-Frequency quality estimate	TRUE
-Non frequency related cell reporting quantities	
-Cell synchronisation information reporting indicator	TRUE
-Cell Identity reporting indicator	TRUE
-CHOICE mode	FDD
-CPICH Ec/N0 reporting indicator	TRUE
-CPICH RSCP reporting indicator	TRUE
-Pathloss reporting indicator	FALSE
-Reporting cell status	
-CHOICE reported cell	Report cells within monitored set on non-used frequency
-Maximum number of reported cells	2
-Measurement validity	Not Present
-Inter-frequency set update	Not Present
-CHOICE report criteria	Periodical reporting criteria
-Amount of reporting	Infinity
-Reporting interval	500 ms
Physical channel information elements	
-DPCH compressed mode status info	Not Present

MEASUREMENT REPORT message for Inter frequency test cases

This message is common for all inter frequency test cases in clause 8.7 and is described in Annex I.

8.7.3.1.5 Test requirements

The UTRA Carrier RSSI absolute measurement accuracy shall meet the requirements in clause 8.7.3.1.2. The effect of assumed thermal noise and noise generated in the receiver (-99 dBm for Band I, IV, VI and X, -98dBm for Band IX, -97 dBm for Band II, V, VII and XI, -96 dBm for Band III and VIII) shall be added into the required accuracy defined in subclause 8.7.3.1.2 as shown in table 8.7.3.1.3.

Table 8.7.3.1.3: UTRA Carrier RSSI absolute accuracy, test requirements

Parameter	Unit	Accuracy [dB]					
		Normal condition			Extreme condition		
		Test 1	Test 2	Test 3	Test 1	Test 2	Test 3
UTRA Carrier RSSI	dBm	± 7.15	± 5.1	-5...5.8	± 10.15	± 8.1	-8...8.8

The normative reference for this requirement is TS 25.133 [2] clause A.9.1.3.2.

Table 8.7.3.1.4: UTRA Carrier RSSI Inter frequency absolute accuracy test parameters

Parameter		Unit	Test 1		Test 2		Test 3	
			Cell 1	Cell 2	Cell 1	Cell 2	Cell 1	Cell 2
UTRA RF Channel number			Channel 1	Channel 2	Channel 1	Channel 2	Channel 1	Channel 2
CPICH_Ec/Ior		dB	-10		-10		-10	
PCCPCH_Ec/Ior		dB	-12		-12		-12	
SCH_Ec/Ior		dB	-12		-12		-12	
PICH_Ec/Ior		dB	-15		-15		-15	
DPCH_Ec/Ior		dB	-15	-	-6	-	-6	-
OCNS_Ec/Ior		dB	-1.11	-0.94	-2.56	-0.94	-2.56	-0.94
Ior	Band I, IV, VI, X	dBm/ 3.84 MHz	-53.5	-53.5	-69.27	-69.27	-93.46	-93.46
	Band IX*						-92.46	-92.46
	Band II, V, VII, XI						-91.46	-91.46
	Band III, VIII						-90.46	-90.46
Ior/Ioc		dB	-1.45	-1.45	-4.4	-4.4	-9.24	-9.24
CPICH Ec/Io, Note 1		dBm	-13.8	-13.8	-15.7	-15.7	-19.7	-19.7
Io, Note 1	Band I, IV, VI, X	dBm/3.84 MHz	-51.15	-51.15	-67.9	-67.9	-93	-93
	Band IX*						-92	-92
	Band II, V, VII, XI						-91	-91
	Band III, VIII						-90	-90
Propagation condition		-	AWGN		AWGN		AWGN	
NOTE 1: CPICH Ec/Io and Io levels have been calculated from other parameters for information purposes. They are not settable parameters themselves.								
*) For the UE which supports both Band III and Band IX operating frequencies, the measurement performance requirements for Band III shall apply to the multi-band UE.								
Tests shall be done sequentially. Test 1 shall be done first. After test 1 has been executed test parameters for tests 2 and 3 shall be set within 5 seconds so that UE does not loose the Cell 2 in between the tests.								

The reported values for the UTRA Carrier RSSI absolute measurement shall meet the requirements in table 8.7.3.1.5.

Table 8.7.3.1.5: UTRA Carrier RSSI absolute accuracy requirements for the reported values

	Test 1	Test 2	Test 3
Normal Conditions			
Lowest reported value (Cell 2)	UTRA_carrier_RSSI_LEV_4 2	UTRA_carrier_RSSI_LEV_2 7	UTRA_carrier_RSSI_LEV_0 2
Highest reported value (Cell 2)	UTRA_carrier_RSSI_LEV_5 7	UTRA_carrier_RSSI_LEV_3 8	UTRA_carrier_RSSI_LEV_1 3
Extreme Conditions			
Lowest reported value (Cell 2)	UTRA_carrier_RSSI_LEV_3 9	UTRA_carrier_RSSI_LEV_2 4	UTRA_carrier_RSSI_LEV_0 0
Highest reported value (Cell 2)	UTRA_carrier_RSSI_LEV_6 0	UTRA_carrier_RSSI_LEV_4 1	UTRA_carrier_RSSI_LEV_1 6

NOTE: If the above Test Requirement differs from the Minimum Requirement then the Test Tolerance applied for this test is non-zero. The Test Tolerance for this test is defined in clause F.2 and the explanation of how the Minimum Requirement has been relaxed by the Test Tolerance is given in clause F.4.

8.7.3.2 Relative measurement accuracy requirement

8.7.3.2.1 Definition and applicability

The relative accuracy requirement is defined as the UTRA Carrier RSSI measured from one frequency compared to the UTRA Carrier RSSI measured from another frequency.

The requirements and this test apply for Release 6 and later releases to all types of UTRA for the FDD UE.

8.7.3.2.2 Minimum Requirements

The accuracy requirements in table 8.7.3.2.1 are valid under the following condition:

$$|\text{Channel 1}_{\text{Io}}|_{\text{dBm}/3.84 \text{ MHz}} - |\text{Channel 2}_{\text{Io}}|_{\text{dBm}/3.84 \text{ MHz}} < 20 \text{ dB.}$$

Table 8.7.3.2.1: UTRA Carrier RSSI Inter frequency relative accuracy

Parameter	Unit	Accuracy [dB]		Conditions			
		Normal condition	Extreme condition	Band I, IV, VI and X	Band IX	Band II, V, VII and XI	Band III and VIII
				Io [dBm/3.84 MHz]	Io [dBm/3.84 MHz]	Io [dBm/3.84 MHz]	Io [dBm/3.84 MHz]
UTRA Carrier RSSI	dBm	± 7	± 11	-94...-50	-93...-50	-92...-50	-91...-50

The normative reference for this requirement is TS 25.133 [2] clause 9.1.3.2.

8.7.3.2.3 Test purpose

The purpose of this test is to verify that the UTRA Carrier RSSI measurement is within the specified limits. This measurement is for inter-frequency handover evaluation.

8.7.3.2.4 Method of test

8.7.3.2.4.1 Initial conditions

Test environment: normal, TL/VL, TL/VH, TH/VL, TH/VH; see clauses G.2.1 and G.2.2.

Frequencies to be tested: mid range; see clause G.2.4.

In this case all cells are on different frequencies and compressed mode is applied. The gap length is 7, detailed definition is in clause C.5, Set 1 of table C.5.2 except for TGRRC and TGCFN. TGPRC and TGCFN shall set to "Infinity" and "(Current CFN + (256 – TTI/10msec))mod 256". UTRA Carrier RSSI relative accuracy requirements are tested by using test parameters in table 8.7.3.2.1A. UTRA carrier RSSI measurements of neighbour cell 2 and neighbour cell 3 are reported to serving cell 1.

Table 8.7.3.2.1A: UTRA Carrier RSSI Inter frequency relative accuracy test parameters

Parameter	Unit	Test 1			Test 2			Test 3			
		Cell 1	Cell 2	Cell 3	Cell 1	Cell 2	Cell 3	Cell 1	Cell 2	Cell 3	
UTRA RF Channel number		Channel 1	Channel 2	Channel 3	Channel 1	Channel 2	Channel 3	Channel 1	Channel 2	Channel 3	
CPICH_Ec/Ior	dB	-10			-10			-10			
PCCPCH_Ec/Ior	dB	-12			-12			-12			
SCH_Ec/Ior	dB	-12			-12			-12			
PICH_Ec/Ior	dB	-15			-15			-15			
DPCH_Ec/Ior	dB	-15	-	-	-6	-	-	-6	-	-	
OCNS_Ec/Ior	dB	-1.11	-0.94	-0.94	-2.56	-0.94	-0.94	-2.56	-0.94	-0.94	
Ior	Band I, IV, VI, X	dBm/ 3.84 MHz	-52.23	-52.23	-71.23	-91.27	-91.27	-81.27	-94.45	-94.45	-75.45
	Band IX*								-93.45	-93.45	-74.45
	Band II, V, VII, XI								-92.45	-92.45	-73.45
	Band III, VIII								-91.45	-91.45	-72.45
Ior/Ioc	dB	-1.75	-1.75	-1.75	-4.7	-4.7	-4.7	-9.54	-9.54	-9.54	
CPICH Ec/Io, Note 1	dBm	-14.0	-14.0	-14.0	-16.0	-16.0	-16.0	-20.0	-20.0	-20.0	
Ioc, Note 1	Band I, IV, VI, X	dBm/ 3.84 MHz	-50 (Note 2)	-50	-69	-90 (Note 2)	-90	-80	-94 (Note 2)	-94	-75
	Band IX*								-93 (Note 2)	-93	-74
	Band II, V, VII, XI								-92 (Note 2)	-92	-73
	Band III, VIII								-91 (Note 2)	-91	-72
Propagation condition	-	AWGN			AWGN			AWGN			
NOTE 1: CPICH Ec/Io and Ioc levels have been calculated from other parameters for information purposes. They are not settable parameters themselves.											
NOTE 2: Ioc levels are not reported by the UE on cell 1.											
*) For the UE which supports both Band III and Band IX operating frequencies, the measurement performance requirements for Band III shall apply to the multi-band UE.											
Tests shall be done sequentially. Test 1 shall be done first. After test 1 has been executed test parameters for tests 2 and 3 shall be set within 5 seconds so that UE does not lose Cell 2 or Cell 3 in between the tests.											

The normative reference for this requirement is TS 25.133 [2] clause A.9.1.3.2.

8.7.3.2.4.2 Procedure

- 1) A call is set up according to the test procedure specified in TS 34.108 [3] clause 7.3.2. The RF parameters for Test 1 are set up according to table 8.7.3.2.3.
- 2) SS shall transmit PHYSICAL CHANNEL RECONFIGURATION message.
- 3) UE shall transmit PHYSICAL CHANNEL RECONFIGURATION COMPLETE message.
- 4) SS shall transmit MEASUREMENT CONTROL message. The SS shall wait 6.8 seconds to allow UE to be ready for inter frequency measurements.
- 5) UE shall transmit periodically MEASUREMENT REPORT messages.
- 6) SS shall check UTRA carrier RSSI value of Channel 2 and Channel 3 in MEASUREMENT REPORT messages. UTRA carrier RSSI power value measured from Channel 3 is compared to UTRA carrier RSSI power value measured from Channel 2 for each MEASUREMENT REPORT message.
- 7) The result of step 6) is compared to actual power level difference of UTRA Carrier RSSI of Channel 3 and Channel 2.
- 8) SS shall count number of MEASUREMENT REPORT messages transmitted by UE. After 1000 MEASUREMENT REPORT messages have been received from UE, the RF parameters are set up according to table 8.7.3.2.3 for Test 2. While RF parameters are being set up, MEASUREMENT REPORT messages from

UE are ignored. SS shall wait for additional 1s and ignore the MEASUREMENT REPORT messages during this period. Then, steps 6) and 7) above are repeated. After further 1000 MEASUREMENT REPORT messages have been received from UE, the RF parameters are set up according to table 8.7.3.2.3 for Test 3. While RF parameters are being set up, MEASUREMENT REPORT messages from UE are ignored. SS shall wait for additional 1s and ignore the MEASUREMENT REPORT messages during this period. Then, steps 6) and 7) above are repeated.

9) After further 1000 MEASUREMENT REPORT messages have been received from UE, the SS shall transmit RRC CONNECTION RELEASE message.

10) UE shall transmit RRC CONNECTION RELEASE COMPLETE message.

Specific Message Contents

All messages indicated above shall use the same content as described in default message content in clause 9 of 34.108 [3], with the following exceptions:

PHYSICAL CHANNEL RECONFIGURATION message for Inter frequency measurement (step 2):

Information Element	Value/Remark	Version
Message Type		
UE Information Elements		
-RRC transaction identifier	0	
-Integrity check info		
-message authentication code	SS calculates the value of MAC-I for this message and writes to this IE. The first/ leftmost bit of the bit string contains the most significant bit of the MAC-I.	
-RRC message sequence number	SS provides the value of this IE, from its internal counter.	
-Integrity protection mode info	Not Present	
-Ciphering mode info	Not Present	
-Activation time	Not Present	
-New U-RNTI	Not Present	
-New C-RNTI	Not Present	
-RRC State Indicator	CELL_DCH	
-UTRAN DRX cycle length coefficient	Not Present	
CN Information Elements		
-CN Information info	Not Present	
UTRAN mobility information elements		
-URA identity	Not Present	
RB information elements		
-Downlink counter synchronisation info	Not Present	
PhyCH information elements		
-Frequency info	Not Present	
Uplink radio resources		
-Maximum allowed UL TX power	Not Present	
- CHOICE channel requirement	Not Present	
Downlink radio resources		
-CHOICE mode	FDD	
-Downlink PDSCH information	Not Present	R99 and Rel-4 only
-Downlink information common for all radio links		
-Downlink DPCH info common for all RL	Not Present	
-CHOICE mode	FDD	
-DPCH compressed mode info		
-Transmission gap pattern sequence		
-TGPSI	1	
-TGPS Status Flag	Activate	
-TGCFN	(Current CFN + (256 – TTI/10msec))mod 256	
-Transmission gap pattern sequence		
configuration parameters		
-TGMP	FDD measurement	
-TGPRC	Infinity	
-TGSN	4	
-TGL1	7	
-TGL2	Not Present	
-TGD	UNDEFINED	
-TGPL1	3	
-TGPL2	Not Present	R99 and Rel-4 only
-RPP	Mode 0	
-ITP	Mode 0	
-CHOICE UL/DL mode	UL and DL	
-Downlink compressed mode method	SF/2	
-Uplink compressed mode method	SF/2	
-Downlink frame type	B	
-DeltaSIR1	3.0	
-DeltaSIRafter1	3.0	
-DeltaSIR2	Not Present	
-DeltaSIRafter2	Not Present	
-N Identify abort	Not Present	
-T Reconfirm abort	Not Present	
-TX Diversity Mode	Not Present	
-SSDT information	Not Present	R99 and Rel-4 only

-Default DPCH Offset Value	Not Present	
-Downlink information per radio link list		
-Downlink information for each radio link		
-Choice mode	FDD	
-Primary CPICH info		
-Primary scrambling code	100	
-PDSCH with SHO DCH Info	Not Present	R99 and Rel-4 only
-PDSCH code mapping	Not Present	R99 and Rel-4 only
-Downlink DPCH info for each RL		
-CHOICE mode	FDD	
-Primary CPICH usage for channel estimation	Primary CPICH may be used	
-DPCH frame offset	Set to value Default DPCH Offset Value (as currently stored in SS) mod 38400	
-Secondary CPICH info	Not Present	
-DL channelisation code		
-Secondary scrambling code	Not Present	
-Spreading factor	128	
-Code number	96	
-Scrambling code change	No code change	
-TPC combination index	0	
-SSDT Cell Identity	Not Present	R99 and Rel-4 only
-Closed loop timing adjustment mode	Not Present	
-SCCPCH Information for FACH	Not Present	

MEASUREMENT CONTROL message for Inter frequency measurement (step 4):

Information Element	Value/Remark
Message Type	
UE information elements -RRC transaction identifier -Integrity check info -message authentication code -RRC message sequence number	0 SS calculates the value of MAC-I for this message and writes to this IE. The first/leftmost bit of the bit string contains the most significant bit of the MAC-I. SS provides the value of this IE, from its internal counter.
Measurement Information elements -Measurement Identity -Measurement Command -Measurement Reporting Mode - Measurement Report Transfer Mode - Periodical Reporting / Event Trigger Reporting Mode -Additional measurement list -CHOICE Measurement Type -Inter-frequency measurement -Inter-frequency cell info list -CHOICE Inter-frequency cell removal -New inter-frequency cells -Cell for measurement -Inter-frequency measurement quantity -CHOICE reporting criteria -Filter coefficient -CHOICE mode -Measurement quantity for frequency quality estimate -Inter-frequency reporting quantity -UTRA Carrier RSSI -Frequency quality estimate -Non frequency related cell reporting quantities -Cell synchronisation information reporting indicator -Cell Identity reporting indicator -CHOICE mode -CPICH Ec/N0 reporting indicator -CPICH RSCP reporting indicator -Pathloss reporting indicator -Reporting cell status -CHOICE reported cell -Maximum number of reported cells -Measurement validity -Inter-frequency set update -CHOICE report criteria -Amount of reporting -Reporting interval	2 Setup Acknowledged mode RLC Periodical reporting Not Present Inter-frequency measurement Not Present Cell 2 and Cell 3 information are included. Not Present Inter-frequency reporting criteria 0 FDD CPICH RSCP TRUE TRUE TRUE TRUE FDD TRUE TRUE Report cells within monitored set on non-used frequency 3 Not Present Not Present Periodical reporting criteria Infinity 500 ms
Physical channel information elements -DPCH compressed mode status info	Not Present

MEASUREMENT REPORT message for inter frequency test cases

This message is common for all inter frequency test cases in clause 8.7 and is described in Annex I.

8.7.3.2.5 Test requirements

The UTRA Carrier RSSI relative measurement accuracy shall meet the requirements in clause 8.7.3.2.2. The effect of assumed thermal noise and noise generated in the receiver (-99 dBm for Band I, IV, VI and X, -98dBm for Band IX, -97 dBm for Band II, V, VII and XI, -96 dBm for Band III and VIII) shall be added into the required accuracy defined in clause 8.7.3.2.2 as shown in table 8.7.3.2.2.

Table 8.7.3.2.2: UTRA Carrier RSSI relative accuracy, test requirements

Parameter	Unit	Accuracy [dB]					
		Normal condition			Extreme condition		
		Test 1	Test 2	Test 3	Test 1	Test 2	Test 3
UTRA Carrier RSSI	dBm	± 7.9	± 8.8	± 8.9	± 11.9	± 12.8	± 12.9

Table 8.7.3.2.3: UTRA Carrier RSSI Inter frequency relative accuracy test parameters

Parameter	Unit	Test 1			Test 2			Test 3			
		Cell 1	Cell 2	Cell 3	Cell 1	Cell 2	Cell 3	Cell 1	Cell 2	Cell 3	
UTRA RF Channel number		Channel 1	Channel 2	Channel 3	Channel 1	Channel 2	Channel 3	Channel 1	Channel 2	Channel 3	
CPICH_Ec/lor	dB	-10			-10			-10			
PCCPCH_Ec/lor	dB	-12			-12			-12			
SCH_Ec/lor	dB	-12			-12			-12			
PICH_Ec/lor	dB	-15			-15			-15			
DPCH_Ec/lor	dB	-15	-	-	-6	-	-	-6	-	-	
OCNS_Ec/lor	dB	-1.11	-0.94	-0.94	-2.56	-0.94	-0.94	-2.56	-0.94	-0.94	
lor	Band I, IV, VI, X	dBm/3.84 MHz	-53.50	-53.50	-71.23	-91.27	-91.27	-81.27	-93.45	-93.45	-74.45
	Band IX*								-92.45	-92.45	-73.45
	Band II, V, VII, XI								-91.45	-91.45	-72.45
	Band III, VIII								-90.45	-90.45	-71.45
lor/loc	dB	-1.45	-1.45	-1.45	-4.4	-4.4	-4.4	-9.24	-9.24	-9.24	
CPICH Ec/lo, Note 1	dBm	-13.7	-13.7	-13.7	-15.7	-15.7	-15.7	-19.7	-19.7	-19.7	
lo, Note 1	Band I, IV, VI, X	dBm/3.84 MHz	-51.15 (Note 2)	-51.15	-69	-90 (Note 2)	-90	-80	-93 (Note 2)	-93	-74
	Band IX*								-92 (Note 2)	-92	-73
	Band II, V, VII, XI								-91 (Note 2)	-91	-72
	Band III, VIII								-90 (Note 2)	-90	-71
Propagation condition	-	AWGN			AWGN			AWGN			
NOTE 1: CPICH Ec/lo and lo levels have been calculated from other parameters for information purposes. They are not settable parameters themselves.											
NOTE 2: lo levels are not reported by the UE on cell 1.											
*) For the UE which supports both Band III and Band IX operating frequencies, the measurement performance requirements for Band III shall apply to the multi-band UE.											
Tests shall be done sequentially. Test 1 shall be done first. After test 1 has been executed test parameters for tests 2 and 3 shall be set within 5 seconds so that UE does not loose Cell 2 or Cell 3 in between the tests.											
The frequency separation among 3 cells shall be at least 10 MHz to avoid overlapping the AWGN interference coming from different loc sources.											

The reported values for the UTRA Carrier RSSI relative measurement shall meet the requirements in table 8.7.3.2.4.

Table 8.7.3.2.4: UTRA Carrier RSSI relative accuracy requirements for the reported values

	Test 1	Test 3	Test 3
Normal Conditions			
Lowest reported value (Cell 3)	UTRA_carrier_RSSI_LEV_(x - 26)	UTRA_carrier_RSSI_LEV_(x + 1)	UTRA_carrier_RSSI_LEV_(x + 10)
Highest reported value (Cell 3)	UTRA_carrier_RSSI_LEV_(x - 10)	UTRA_carrier_RSSI_LEV_(x + 19)	UTRA_carrier_RSSI_LEV_(x + 28)
Extreme Conditions			
Lowest reported value (Cell 3)	UTRA_carrier_RSSI_LEV_(x - 30)	UTRA_carrier_RSSI_LEV_(x - 3)	UTRA_carrier_RSSI_LEV_(x + 6)
Highest reported value (Cell 3)	UTRA_carrier_RSSI_LEV_(x - 6)	UTRA_carrier_RSSI_LEV_(x + 23)	UTRA_carrier_RSSI_LEV_(x + 32)
UTRA_carrier_RSSI_LEV_x is the reported value of cell 2			

NOTE: If the above Test Requirement differs from the Minimum Requirement then the Test Tolerance applied for this test is non-zero. The Test Tolerance for this test is defined in clause F.2 and the explanation of how the Minimum Requirement has been relaxed by the Test Tolerance is given in clause F.4.

8.7.3A GSM Carrier RSSI

8.7.3A.1 Definition and applicability

The GSM carrier RSSI measurement is used for handover between UTRAN and GSM.

The requirements and this test apply to the combined FDD and GSM UE.

8.7.3A.2 Minimum Requirements

The UE shall meet the measurement accuracy requirements stated for RXLEV below, when the given measurement time allows the UE to take at least 3 GSM carrier RSSI samples per GSM carrier in the monitored set during the measurement period.

The absolute accuracy shall be as follows:

The R.M.S received signal level at the receiver input shall be measured by the UE and the BSS over the full range of -110 dBm to -48 dBm with an absolute accuracy of ± 4 dB from -110 dBm to -70 dBm under normal conditions and ± 6 dB over the full range under both normal and extreme conditions. The R.M.S received signal level at the receiver input shall be measured by the UE above -48 dBm up to -38 dBm with an absolute accuracy of ± 9 dB under both normal and extreme conditions.

If the received signal level falls below the reference sensitivity level for the type of UE or BSS, then the measured level shall be within the range allowing for the absolute accuracy specified above. In case the upper limit of this range is below the reference sensitivity level for the type of UE or BSS, then the upper limit shall be considered as equal to the reference sensitivity level.

The relative accuracy shall be as follows:

If signals of level x_1 and x_2 dBm are received (where $x_1 \leq x_2$) and levels y_1 and y_2 dBm respectively are measured, if $x_2 - x_1 < 20$ dB and x_1 is not below the reference sensitivity level, then y_1 and y_2 shall be such that:

$(x_2 - x_1) - a \leq y_2 - y_1 \leq (x_2 - x_1) + b$ if the measurements are on the same or on different RF channel within the same frequency band;

and

$(x_2 - x_1) - c \leq y_2 - y_1 \leq (x_2 - x_1) + d$ if the measurements are on different frequency bands:

a, b, c and d are in dB and depend on the value of x_1 as follows:

	a	b	c	d
$x1 \geq s+14, x2 < -48$ dBm	2	2	4	4
$s+14 > x1 \geq s+1$	3	2	5	4
$s+1 > x1$	4	2	6	4

For single band MS or BTS and measurements between ARFCN in the same band for a multiband MS or BTS;

s = reference sensitivity level as specified in 3GPP TS 05.05 [28] for R99 and in 3GPP TS 45.005 [29] for Rel-4 and later releases.

For measurements between ARFCN in different bands;

s = the reference sensitivity level as specified in [28] and [29] for the band including x1.

At extreme temperature conditions an extra 2 dB shall be added to c and d in above table.

The selectivity of the received signal level measurement shall be as follows:

- for adjacent (200 kHz) channel ≥ 16 dB;
- for adjacent (400 kHz) channel ≥ 48 dB;
- for adjacent (600 kHz) channel ≥ 56 dB.

The selectivity shall be met using random, continuous, GSM-modulated signals with the wanted signal at the level 20 dB above the reference sensitivity level.

The reporting range and mapping specified for RXLEV in TS 05.08[20] for R99 and in TS 45.008 [30] for Rel-4 and later releases shall apply.

The rate of correct measurements observed during repeated tests shall be at least 90%.

The normative reference for this requirement is:

For R99: TS 25.133 [2] clause 8.1.2.5 and 9.1.4 and TS 05.08 [20] clause 8.1.2.

For Rel-4 and later releases: TS 25.133 [2] clause 8.1.2.5 and 9.1.4 and TS 45.008 [30] clause 8.1.2.

8.7.3A.3 Test purpose

The purpose of this test is to verify that the GSM Carrier RSSI measurement accuracy in CELL_DCH state, for UE that needs compressed mode to perform GSM measurements, is within the specified limits. This measurement is for UTRAN to GSM handover evaluation.

8.7.3A.4 Method of test

8.7.3A.4.1 Initial conditions

Test environment: normal, TL/VL, TH/VH; see clauses G.2.1 and G.2.2.

Frequencies to be tested: mid range; see clause G.2.4.

In the test in Cell_DCH state compressed mode with purpose "GSM Carrier RSSI Measurement" is applied to measure on GSM. The gap length is 7, detailed definition is in clause C.5, Set 2 of table C.5.2 except for TGPRC and TGCFN. TGPRC and TGCFN shall set to "Infinity" and "(Current CFN + (256 - TTI/10msec))mod 256". Table 8.7.3A.1 defines the limits of signal strengths and code powers on the UMTS FDD cell, where the requirement is applicable. In the measurement control information it is indicated to the UE that periodic reporting of the GSM RSSI measurement.

The requirements are also applicable for a UE not requiring compressed mode, in which case no compressed mode pattern should be sent for the parameters specified in table 8.7.3A.1.

Table 8.7.3A.1: General GSM Carrier RSSI test parameters

Parameter	Unit	Value	Comment
DCH parameters		DL Reference Measurement Channel 12.2 kbps	As specified in section C.3.1
Power Control		On	
Target quality value on DTCH	BLER	0.01	
Compressed mode patterns - GSM carrier RSSI measurement		Compressed mode reference pattern 2 Set 2	As specified in table C.5.2 section C.5
Inter-RAT measurement quantity		GSM Carrier RSSI	
BSIC verification required		Not required	
Monitored cell list size		6 GSM neighbours	See Annex I for cell information Measurement control information is sent before the compressed mode patterns starts.

Table 8.7.3A.2: Cell specific GSM Carrier RSSI test parameters

Parameter	Unit	Cell 1
UTRA RF Channel number	-	Channel 1
lor/loc	dB	-1
loc	dBm/ 3.84 MHz	-70
Propagation condition	-	AWGN

Table 8.7.3A.3: Signal levels at receiver input in dBm

Step	BCCH1	BCCH2	BCCH3	BCCH4	BCCH5	BCCH6
1	-38.5	-38.5	NA	NA	NA	NA
2	-48.5	-48.5	NA	NA	NA	NA
3	-70.5	-70.5	NA	NA	NA	NA
4	-109.5	-109.5	NA	NA	NA	NA
5	-57.5	NA	-54.5	NA	NA	NA
6	-64.5	NA	-59.5	NA	NA	NA
7	-71.5	NA	NA	-64.5	NA	NA
8	-78.5	NA	NA	-69.5	NA	NA
9	-85.5	NA	NA	NA	-74.5	NA
10	-92.5	NA	NA	NA	-79.5	NA
11	-99.5	NA	NA	NA	NA	-84.5
12	-106.5	NA	NA	NA	NA	-89.5

Table 8.7.3A.4: ARFCN numbers for GSM cells

GSM band	BCCH1	BCCH2	BCCH3	BCCH4	BCCH5	BCCH6
GSM 450	276	293	264	269	281	288
GSM 480	323	340	311	316	328	335
GSM 900	62	124	20	40	80	100
DCS 1800	700	885	585	660	790	835
PCS 1900	700	805	585	660	790	550
450/900	124	276	293	269	288	1
480/900	124	323	340	316	335	1
450/1800	885	276	293	269	288	512
480/1800	885	323	340	316	335	512
900/1800	885	62	124	40	100	512
450/900/1800	124	276	885	293	1	512
480/900/1800	124	323	885	340	1	512
GSM 850 for FDD Band V and VI (Note)	220	251	150	160	210	230
GSM 850 for FDD bands ≠ FDD Band V and VI	189	251	150	170	210	230
GSM 750	475	511	440	455	485	500
750/850	251	475	511	455	485	128

Note: The following BCCH ARFCN's specified for FDD Band V and VI provide enough gap for a UMTS cell and its AWGN to be setup with center frequency at UARFCN number 4400.

8.7.3A.4.2 Procedure

- 1) A call is set up according to the test procedure specified in TS 34.108 [3] clause 7.3.2. The RF parameters for cell 1 are set up according to table 8.7.3A.1 and 8.7.3A.2.
- 2) The RF parameters for two GSM cells are set up according to the step 1 in table 8.7.3A.5. The fading profile for the BCCHs will be set to static, see 51.010-1 [25]. The ARFCN numbers for GSM cells are set up according to table 8.7.3A.4.
- 3) SS shall transmit PHYSICAL CHANNEL RECONFIGURATION message.
- 4) UE shall transmit PHYSICAL CHANNEL RECONFIGURATION COMPLETE message.
- 5) SS shall transmit MEASUREMENT CONTROL message.
- 6) UE shall transmit periodically MEASUREMENT REPORT messages.
- 7) SS shall check GSM carrier RSSI value of the two GSM cells in MEASUREMENT REPORT messages. The GSM CARRIER RSSI values reported in the first measurement report are discarded. The SS records repeatedly GSM CARRIER RSSI values reported for the two BCCHs in each step. One report produces more than one mapped level or level difference. If the UE reports a value compliant with the applicable Table 8.7.3A.6 or 8.7.3A.7 or 8.7.3A.8 or 8.7.3A.9 then a success is recorded. Otherwise a failure is recorded. The successes and failures are assigned to the individual mapped levels or level differences. Repeat steps 7 according to Annex F.6.2 table 6.2.8. The repetition shall be continued, until the last mapped level or level difference experiences an early decision according to Annex F.6.2.
- 8) The RF parameters for two GSM cells are set up according to the next test step in table 8.7.3A.5.
- 9) Repeat procedure steps 7 and 8 until MEASUREMENT REPORT messages from the test step 12 of Table 8.7.3A.5 have been recorded.

Specific Message Contents

All messages indicated above shall use the same content as described in the system information in clause 6.1.0b of 34.108 [3] and in default message content in clause 9 of 34.108 [3], with the following exceptions:

PHYSICAL CHANNEL RECONFIGURATION message for Inter-RAT measurement (step 3):

Information Element	Value/Remark	Version
Message Type (10.2.22)		
UE Information Elements		
-RRC transaction identifier	0	
-Integrity check info		
-message authentication code	SS calculates the value of MAC-I for this message and writes to this IE. The first/ leftmost bit of the bit string contains the most significant bit of the MAC-I.	
-RRC message sequence number	SS provides the value of this IE, from its internal counter.	
-Integrity protection mode info	Not Present	
-Ciphering mode info	Not Present	
-Activation time	Not Present	
-New U-RNTI	Not Present	
-New C-RNTI	Not Present	
-RRC State Indicator	CELL_DCH	
-UTRAN DRX cycle length coefficient	Not Present	
CN Information Elements		
-CN Information info	Not Present	
UTRAN mobility information elements		
-URA identity	Not Present	
RB information elements		
-Downlink counter synchronisation info	Not Present	
PhyCH information elements		
-Frequency info (10.3.6.36)	Not Present	
Uplink radio resources		
-Maximum allowed UL TX power	33 dBm	
-CHOICE <i>channel requirement</i>	Not Present	
Downlink radio resources		
-CHOICE <i>mode</i>	FDD	
-Downlink PDSCH information	Not Present	R99 and Rel-4 only
-Downlink information common for all radio links (10.3.6.24)		
-Downlink DPCH info common for all RL (10.3.6.18)	Not Present	
-CHOICE <i>mode</i>	FDD	
-DPCH compressed mode info (10.3.6.33)		
- Transmission gap pattern sequence	1	
- TGPSI	1	
- TGPS Status Flag	activate	
- TGCFN	(Current CFN + (256 – TTI/10msec))mod 256	
- Transmission gap pattern sequence configuration parameters		
-TGMP	GSM carrier RSSI measurement	
-TGPRC	Infinity	
-TGSN	4	
-TGL1	7	
-TGL2	Not Present	
-TGD	UNDEFINED	
-TGPL1	12	
-TGPL2	Not Present	R99 and Rel-4 only
-RPP	mode 0	
-ITP	mode 0	
-CHOICE UL/DL mode	UL and DL	
-Downlink compressed mode method	SF/2	
-Uplink compressed mode method	SF/2	
-Downlink frame type	B	
-DeltaSIR1	3.0	
-DeltaSIRafter1	3.0	
-DeltaSIR2	Not Present	
-DeltaSIRafter2	Not Present	
-N Identify abort	Not Present	
-T Reconfirm abort	Not Present	
-TX Diversity mode (10.3.6.86)	None	

Information Element	Value/Remark	Version
-SSDT information (10.3.6.77)	Not Present	R99 and Rel-4 only
-Default DPCH Offset Value (10.3.6.16)	Not Present	
-Downlink information per radio link list	1	R99 and Rel-4 only R99 and Rel-4 only
-Downlink information for each radio link (10.3.6.27)		
-CHOICE mode	FDD	
-Primary CPICH info (10.3.6.60)		
-Primary scrambling code	100	
-PDSCH with SHO DCH info (10.3.6.47)	Not Present	
-PDSCH code mapping (10.3.6.43)	Not Present	
-Downlink DPCH info for each RL (10.3.6.21)		
-CHOICE mode	FDD	
-Primary CPICH usage for channel estimation	Primary CPICH may be used	
-DPCH frame offset	Set to value Default DPCH Offset Value (as currently stored in SS) mod 38400	
-Secondary CPICH info	Not Present	R99 and Rel-4 only
-DL channelisation code		
-Secondary scrambling code	Not Present	
-Spreading factor	128	
-Code number	96	
-Scrambling code change	No change	
-TPC combination index	0	
-SSDT Cell Identity	Not Present	
- Closed loop timing adjustment mode	Not Present	
- SCCPCH information for FACH (10.3.6.70)	Not Present	

MEASUREMENT CONTROL message for Inter-RAT measurement (step 5):

Information Element/Group name	Value/Remark	Version
Message Type (10.2.17)		
UE information elements		
-RRC transaction identifier	0	
-Integrity check info		
-message authentication code	SS calculates the value of MAC-I for this message and writes to this IE. The first/leftmost bit of the bit string contains the most significant bit of the MAC-I.	
-RRC message sequence number	SS provides the value of this IE, from its internal counter.	
Measurement Information elements		
-Measurement Identity	2	
-Measurement Command (10.3.7.46)	Setup	
-Measurement Reporting Mode (10.3.7.49)		
-Measurement Report Transfer Mode	AM RLC	
-Periodical Reporting / Event Trigger Reporting Mode	Periodical reporting	
-Additional measurements list (10.3.7.1)	Not Present	
-CHOICE <i>Measurement type</i>	Inter-RAT measurement	
-Inter-RAT measurement (10.3.7.27)		
-Inter-RAT measurement objects list (10.3.7.23)		
-CHOICE <i>Inter-RAT cell removal</i>	Remove no inter-RAT cells	
-New inter-RAT cells	6	
-Inter-RAT cell id	9+n (n=0 to 5)	
-CHOICE Radio Access Technology	GSM	
-Cell individual offset	0	
-Cell selection and re-selection info (10.3.2.4)	Not Present	
-BSIC (10.3.8.2)		
-Base transceiver Station Identity Code (BSIC)	BSIC(1+n) for n=0, 1 according to 34.108 [3] Table 6.1.10; for n=2 to 5 chosen arbitrarily by the test house such that it does not collide with BSICs of other Inter-RAT cell ids According to PICS/PIXIT	
-Band indicator	BCCH(1+n) according to Table Table 8.7.3A.4	
-BCCH ARFCN	Not Present	
-Cell for measurement	Not Present	
-Inter-RAT measurement quantity (10.3.7.29)		
-Measurement quantity for UTRAN quality estimate (10.3.7.38)	Not Present	
-CHOICE system	GSM	
-Measurement quantity	GSM Carrier RSSI	
-Filter coefficient	0	
-BSIC verification required	not required	
-Inter-RAT reporting quantity (10.3.7.32)		
-UTRAN estimated quality	FALSE	
-CHOICE system	GSM	
-Observed time difference to GSM cell Reporting indicator	FALSE	R99 and Rel-4 only
-GSM carrier RSSI reporting indicator	TRUE	
-Reporting cell status (10.3.7.61)		
-CHOICE reported cell	Report cells within active set or within virtual active set or of the other RAT	
-Maximum number of reported cells	6	
-CHOICE report criteria	Periodical reporting criteria	
-Periodical reporting criteria (10.3.7.53)		
-Amount of reporting	Infinity	
-Reporting interval	500 ms	
Physical channel information elements		
-DPCH compressed mode status info (10.3.6.34)	Not Present	

MEASUREMENT REPORT message for inter-RAT test cases

This message is common for all inter-RAT test cases in clause 8.7 and is described in Annex I.

8.7.3A.5 Test requirements

Table 8.7.3A.5: Signal levels at receiver input in dBm, test parameters for test requirements

Step	BCCH1	BCCH2	BCCH3	BCCH4	BCCH5	BCCH6
1	-39.5	-39.5	NA	NA	NA	NA
2	-49.5	-49.5	NA	NA	NA	NA
3	-71.5	-71.5	NA	NA	NA	NA
4	-108.5	-108.5	NA	NA	NA	NA
5	-57.5	NA	-54.5	NA	NA	NA
6	-64.5	NA	-59.5	NA	NA	NA
7	-71.5	NA	NA	-64.5	NA	NA
8	-78.5	NA	NA	-69.5	NA	NA
9	-85.5	NA	NA	NA	-74.5	NA
10	-92.5	NA	NA	NA	-79.5	NA
11	-99.5	NA	NA	NA	NA	-84.5
12	-106.5	NA	NA	NA	NA	-89.5

For the UE preliminarily to pass the absolute requirements of GSM Carrier RSSI measurement, at least 90% of the reported GSM Carrier RSSI measurements shall fulfill the following test requirements for each step and each test environment with a confidence level of 95%.

Table 8.7.3A.6: GSM Carrier RSSI absolute accuracy requirements for the reported values

Step	Normal		TL/VL & TH/VH	
	Lowest reported value for BCCH1	Highest reported value for BCCH1	Lowest reported value for BCCH1	Highest reported value for BCCH1
1	RXLEV = 61	RXLEV = 63	RXLEV = 61	RXLEV = 63
2	RXLEV = 54	RXLEV = 63	RXLEV = 54	RXLEV = 63
3	RXLEV = 34	RXLEV = 44	RXLEV = 32	RXLEV = 46
4	RXLEV = 00	RXLEV = 09	RXLEV = 00	RXLEV = 09
5	RXLEV = 46	RXLEV = 60	RXLEV = 46	RXLEV = 60
6	RXLEV = 39	RXLEV = 53	RXLEV = 39	RXLEV = 53
7	RXLEV = 34	RXLEV = 44	RXLEV = 32	RXLEV = 46
8	RXLEV = 27	RXLEV = 37	RXLEV = 25	RXLEV = 39
9	RXLEV = 20	RXLEV = 30	RXLEV = 18	RXLEV = 32
10	RXLEV = 13	RXLEV = 23	RXLEV = 11	RXLEV = 25
11	RXLEV = 06	RXLEV = 16	RXLEV = 04	RXLEV = 18
12	RXLEV = 00	RXLEV = 09	RXLEV = 00	RXLEV = 11

Note: It is not mandatory for the UE to report BCCH1 in step 12

For the UE preliminarily to pass the relative requirements of GSM Carrier RSSI measurement, at least 90% of the reported GSM Carrier RSSI measurements shall fulfill the following test requirements for each step and each test environment with a confidence level of 95%.

Table 8.7.3A.7: GSM Carrier RSSI Relative accuracy requirements for the reported values, measurements on different ARFCN within the same frequency band

Step	Normal & TL/VL & TH/VH	
	Lowest reported value for BCCH2	Highest reported value for BCCH2
1	No requirements	No requirements
2	RXLEV = x-4	RXLEV = x+4
3	RXLEV = x-4	RXLEV = x+4
4	RXLEV = x-6	RXLEV = x+4
	Lowest reported value for BCCH3	Highest reported value for BCCH3
5	RXLEV = x-1	RXLEV = x+7
6	RXLEV = x+1	RXLEV = x+9
	Lowest reported value for BCCH4	Highest reported value for BCCH4
7	RXLEV = x+3	RXLEV = x+11
8	RXLEV = x+5	RXLEV = x+13
	Lowest reported value for BCCH5	Highest reported value for BCCH5
9	RXLEV = x+7	RXLEV = x+15
10	RXLEV = x+8	RXLEV = x+17
	Lowest reported value for BCCH6	Highest reported value for BCCH6
11	RXLEV = x+10	RXLEV = x+19
12	RXLEV = x+11	RXLEV = x+21
x is the reported value RXLEV for BCCH1		
Note: It is not mandatory for the UE to report BCCH1 in step 12		

For the UE preliminarily to pass the relative requirements of GSM Carrier RSSI measurement, at least 90% of the reported GSM Carrier RSSI measurements shall fulfill the following test requirements for each step and each test environment with a confidence level of 95%.

Table 8.7.3A.8: GSM Carrier RSSI Relative accuracy requirements for the reported values, measurements on different frequency bands

Step	Normal		TL/VL & TH/VH	
	Lowest reported value for BCCH2	Highest reported value for BCCH2	Lowest reported value for BCCH2	Highest reported value for BCCH2
1	No requirements	No requirements	No requirements	No requirements
2	RXLEV = x-6	RXLEV = x+6	RXLEV = x-8	RXLEV = x+8
3	RXLEV = x-6	RXLEV = x+6	RXLEV = x-8	RXLEV = x+8
4	RXLEV = x-8	RXLEV = x+6	RXLEV = x-10	RXLEV = x+8
	Lowest reported value for BCCH3	Highest reported value for BCCH3	Lowest reported value for BCCH3	Highest reported value for BCCH3
5	RXLEV = x-3	RXLEV = x+9	RXLEV = x-5	RXLEV = x+11
6	RXLEV = x-1	RXLEV = x+11	RXLEV = x-3	RXLEV = x+13
	Lowest reported value for BCCH4	Highest reported value for BCCH4	Lowest reported value for BCCH4	Highest reported value for BCCH4
7	RXLEV = x+1	RXLEV = x+13	RXLEV = x-1	RXLEV = x+15
8	RXLEV = x+3	RXLEV = x+15	RXLEV = x+1	RXLEV = x+17
	Lowest reported value for BCCH5	Highest reported value for BCCH5	Lowest reported value for BCCH5	Highest reported value for BCCH5
9	RXLEV = x+5	RXLEV = x+17	RXLEV = x+3	RXLEV = x+19
10	RXLEV = x+6	RXLEV = x+19	RXLEV = x+4	RXLEV = x+21
	Lowest reported value for BCCH6	Highest reported value for BCCH6	Lowest reported value for BCCH6	Highest reported value for BCCH6
11	RXLEV = x+8	RXLEV = x+21	RXLEV = x+6	RXLEV = x+23
12	RXLEV = x+9	RXLEV = x+23	RXLEV = x+7	RXLEV = x+25
x is the reported value RXLEV for BCCH1				
Note: It is not mandatory for the UE to report BCCH1 in step 12				

For the UE preliminarily to pass the relative requirements of GSM Carrier RSSI measurement, at least 90% of the reported GSM Carrier RSSI measurements shall fulfill the following test requirements for each step and each test environment with a confidence level of 95%.

Table 8.7.3A.9: GSM Carrier RSSI Relative accuracy requirements for the reported values, measurements at single frequency (BCCH1)

Step n	Step m	Normal & TL/VL & TH/VH	
		Lowest reported value for BCCH1 at step n	Highest reported value for BCCH1 at step n
5	6	RXLEV = x+3	RXLEV = x+11
5	7	RXLEV = x+10	RXLEV = x+18
6	7	RXLEV = x+3	RXLEV = x+11
6	8	RXLEV = x+10	RXLEV = x+18
7	8	RXLEV = x+3	RXLEV = x+11
7	9	RXLEV = x+10	RXLEV = x+18
8	9	RXLEV = x+3	RXLEV = x+11
8	10	RXLEV = x+9	RXLEV = x+18
9	10	RXLEV = x+2	RXLEV = x+11
9	11	RXLEV = x+9	RXLEV = x+18
10	11	RXLEV = x+2	RXLEV = x+11
10	12	RXLEV = x+8	RXLEV = x+18
11	12	RXLEV = x+1	RXLEV = x+11
x is the reported value of BCCH1 at step m			
Note: It is not mandatory for the UE to report BCCH1 in step 12			

For the UE finally to pass, all preliminary decisions must be decided pass.

FFS: 3 test-environments * 12 reporting periods * 3 levels per report = 108 individual pass fail decisions

An individual pass/fail decision has a wrong decision risk of 5%. All individual decisions must pass, to pass the entire test. As a consequence a UE with marginal performance for each individual level will pass each individual test with a probability of 95%, but will fail the entire test with high probability. It is for further study whether to:

- Accept this situation.
- Decrease the wrong decision risk for each individual test at the expense of additional test time, to increase the pass probability for the entire test.
- Introduce allowance to fail a limited number of individual tests.

8.7.3B Transport channel BLER

Void.

8.7.3C UE transmitted power (R99 and Rel-4 only)

8.7.3C.1 Definition and applicability

The UE transmitted power absolute accuracy is defined as difference between the UE reported value and the UE transmitted power measured by test system. The reference point for the UE transmitted power shall be the antenna connector of the UE.

The requirements and this test apply to the R99 and Rel-4 only FDD UE.

8.7.3C.2 Minimum requirements

The measurement period in CELL_DCH state is 1 slot.

Table 8.7.3C.2.1 UE transmitted power absolute accuracy

Parameter	Unit	Accuracy [dB]	
		PUEMAX 24dBm	PUEMAX 21dBm
UE reported power \geq PUEMAX	dBm	+1/-3	± 2
PUEMAX > UE reported power \geq PUEMAX-1	dBm	+1.5/-3.5	± 2.5
PUEMAX-1 > UE reported power \geq PUEMAX-2	dBm	+2/-4	± 3
PUEMAX-2 > UE reported power \geq PUEMAX-3	dBm	+2.5/-4.5	± 3.5
PUEMAX-3 > UE reported power \geq PUEMAX-10	dBm	+3/-5	± 4

NOTE 1: User equipment maximum output power, PUEMAX, is the maximum output power level without tolerance defined for the power class of the UE in TS 25.101 [1] section 6.2.1.

NOTE 2: UE transmitted power is the reported value.

For each empty slot created by compressed mode, no value shall be reported by the UE L1 for those slots.

The normative reference for this requirement is TS 25.133 [2] clause 9.1.6.

8.7.3C.3 Test purpose

The purpose of this test is to verify that for any reported value of UE Transmitted Power in the range PUEMAX to PUEMAX-10 that the actual UE mean power lies within the range specified in clause 8.7.3C.2.

8.7.3C.4 Method of test

8.7.3C.4.1 Initial conditions

Test environment: normal, TL/VL, TL/VH, TH/VL, TH/VH; see clauses G.2.1 and G.2.2.

Frequencies to be tested: mid range; see clause G.2.4.

- 1) Connect SS to the UE antenna connector as shown in figure A.1.

The test parameters are given in Table 8.7.3C.4.1 and 8.7.3C.4.2 below. In the measurement control information it shall be indicated to the UE that periodic reporting of the UE transmitted power measurement shall be used.

Table 8.7.3C.4.1: General test parameters for UE transmitted power

Parameter	Unit	Value	Comment
DCH parameters		DL Reference Measurement Channel 12.2 kbps	As specified in clause C.3.1
DL-Power Control		Off	

Table 8.7.3C.4.2: Cell Specific parameters for UE transmitted power

Parameter	Unit	Cell 1
CPICH_Ec/I _{or}	dB	-10
PCCPCH_Ec/I _{or}	dB	-12
SCH_Ec/I _{or}	dB	-12
PICH_Ec/I _{or}	dB	-15
DPCH_Ec/I _{or}	dB	-3
OCNS_Ec/I _{or}	dB	-5.2
\hat{I}_{or}/I_{oc}	dB	0
I_{oc}	dBm/3.84 MHz	-70
CPICH_Ec/I _o	dB	-13
Propagation Condition		AWGN

8.7.3C.4.2 Procedure

- 1) A call is set up according to the test procedure specified in TS 34.108 [3] subclause 7.3.2. The RF parameters are set up according to table 8.7.3C.4.1 and 8.7.3C.4.2. Set the UE power and Maximum allowed UL TX power to the maximum power for the UE power class.
- 2) SS shall send continuously during the entire test Up power control commands to the UE.
- 3) SS shall transmit the MEASUREMENT CONTROL message as defined in the specific message contents below.
- 4) Decode the UE Transmitted power reported by the UE in the next available MEASUREMENT REPORT message.
- 5) Measure the mean power of the UE over a period of one timeslot.
- 6) Steps 4 and 5 shall be repeated 1000 times.
- 7) Decrease the Maximum allowed UL TX power by 1 dB. The SS shall transmit the PHYSICAL CHANNEL RECONFIGURATION message, as defined in the specific message contents below.
- 8) SS shall wait for the PHYSICAL CHANNEL RECONFIGURATION COMPLETE message from the UE.
- 9) Repeat from step 4) until the Maximum allowed UL TX Power reaches PUEMAX-10.

Specific Message Contents

All messages indicated above shall use the same content as described in default message content in clause 9 of 34.108 [3], with the following exceptions:

MEASUREMENT CONTROL message:

Information Element	Value/Remark
Message Type	
UE information elements	
-RRC transaction identifier	0
-Integrity check info	
-message authentication code	SS calculates the value of MAC-I for this message and writes to this IE. The first/leftmost bit of the bit string contains the most significant bit of the MAC-I.
-RRC message sequence number	SS provides the value of this IE, from its internal counter.
Measurement Information elements	
-Measurement Identity	5
-Measurement Command	SETUP
-CHOICE Measurement type	UE Internal measurement
-UE Internal measurement quantity	
-Measurement quantity	UE Transmitted power
-Filter coefficient	0
-UE Internal reporting quantity	
-UE Transmitted power	TRUE
-CHOICE mode	FDD
-UE Rx-Tx time difference	FALSE
-CHOICE report criteria	Periodical reporting criteria
-Amount of reporting	Infinity
-Reporting interval	250
-Measurement Reporting Mode	
-Measurement Report Transfer Mode	AM RLC
-Periodical Reporting / Event Trigger Reporting Mode	Periodical reporting
-AdditionalMeasurementList	Not Present
Physical channel information elements	
-DPCH compressed mode status info	Not Present

MEASUREMENT REPORT message:

Information Element	Value/remark
Message Type	
Integrity check info	The presence of this IE is dependent on PIXIT statements in TS 34.123-2. If integrity protection is indicated to be active, this IE shall be present with the values of the sub IEs as stated below. Else, this IE and the sub-IEs shall be absent.
- Message authentication code	This IE is checked to see if it is present. The value is compared against the XMAC-I value computed by SS.
- RRC Message sequence number	This IE is checked to see if it is present. The value is used by SS to compute the XMAC-I value.
Measurement identity	5
Measured Results	UE Internal measured results
- CHOICE Measurement	FDD
- Choice mode	Checked that this IE is present
- UE Transmitted power	Checked that this IE is absent
- UE Rx-Tx report entries	Checked that this IE is absent
Measured results on RACH	Checked that this IE is absent
Additional measured results	Checked that this IE is absent
Event results	Checked that this IE is absent

PHYSICAL CHANNEL RECONFIGURATION message:

Information Element	Value/Remark	Version
Message Type		
UE Information Elements		
-RRC transaction identifier	0	
-Integrity check info		
-message authentication code	SS calculates the value of MAC-I for this message and writes to this IE. The first/leftmost bit of the bit string contains the most significant bit of the MAC-I.	
-RRC message sequence number	SS provides the value of this IE, from its internal counter.	
-Integrity protection mode info	Not Present	
-Cipherring mode info	Not Present	
-Activation time	Not Present	
-New U-RNTI	Not Present	
-New C-RNTI	Not Present	
-RRC State Indicator	CELL_DCH	
-UTRAN DRX cycle length coefficient	Not Present	
CN Information Elements		
-CN Information info	Not Present	
UTRAN mobility information elements		
-URA identity	Not Present	
RB information elements		
-Downlink counter synchronisation info	Not Present	
PhyCH information elements		
-Frequency info	Not Present	
Uplink radio resources		
-Maximum allowed UL TX power	At the first time this value is set to PUEMAX-1. After the second time this value is decreased with 1 dB from previous value.	
Downlink radio resources		
-CHOICE mode	FDD	
-Downlink PDSCH information	Not Present	
-Downlink information common for all radio links	Not Present	
-Downlink information per radio link list	Not Present	R99 and R4 only

8.7.3C.5 Test requirements

Compare each of the UE transmitted power reports against the following mean power measurement. At least 90% of the mean power measurements for any one value of reported UE transmitted power shall be within the range specified in table 8.7.3C.5.

Table 8.7.3C.5 UE transmitted power test requirements

UE reported value	SS measured mean power (X) range [dBm]	
	PUEMAX 24dBm	PUEMAX 21dBm
UE_TX_POWER_104	$33-3.7 \leq X < 34+1.7$	$33-2.7 \leq X < 34+2.7$
UE_TX_POWER_103	$32-3.7 \leq X < 33+1.7$	$32-2.7 \leq X < 33+2.7$
•	•	•
•	•	•
•	•	•
UE_TX_POWER_097	$26-3.7 \leq X < 27+1.7$	•
UE_TX_POWER_096	$25-3.7 \leq X < 26+1.7$	•
UE_TX_POWER_095	$24-3.7 \leq X < 25+1.7$	•
UE_TX_POWER_094	$23-4.2 \leq X < 24+2.2$	$23-2.7 \leq X < 24+2.7$
UE_TX_POWER_093	$22-4.7 \leq X < 23+2.7$	$22-2.7 \leq X < 23+2.7$
UE_TX_POWER_092	$21-5.2 \leq X < 22+3.2$	$21-2.7 \leq X < 22+2.7$
UE_TX_POWER_091	$20-5.7 \leq X < 21+3.7$	$20-3.2 \leq X < 21+3.2$
UE_TX_POWER_090	$19-5.7 \leq X < 20+3.7$	$19-3.7 \leq X < 20+3.7$
UE_TX_POWER_089	$18-5.7 \leq X < 19+3.7$	$18-4.2 \leq X < 19+4.2$
UE_TX_POWER_088	•	$17-4.7 \leq X < 18+4.7$
UE_TX_POWER_087	•	$16-4.7 \leq X < 17+4.7$
UE_TX_POWER_086	•	$15-4.7 \leq X < 15+4.7$
•	•	•
•	•	•
•	•	•
UE_TX_POWER_022	$-49-5.7 \leq X < -48+3.7$	$-49-4.7 \leq X < -48+4.7$
UE_TX_POWER_021	$-50-5.7 \leq X < -49+3.7$	$-50-4.7 \leq X < -49+4.7$

NOTE 1: Although test requirements are given for all UE reported values, a good UE will likely report values between PUEMAX and PUEMAX - 10 dB. However, even a good UE may report also wider range of values due to errors in TPC command reception and allowed range specified for UE transmit power setting accuracy when Maximum Allowed UL TX Power has been signaled. On the other hand, a faulty UE may report any power value but then it does not fulfill the Table 8.7.3C.5 requirements for mean power or then it will not pass some other tests e.g. TC 5.2 of this specification.

NOTE 2: If the above Test Requirement differs from the Minimum Requirement then the Test Tolerance applied for this test is non-zero. The Test Tolerance for this test is defined in clause F.2 and the explanation of how the Minimum Requirement has been relaxed by the Test Tolerance is given in clause F.4.

8.7.3D UE transmitted power (Rel-5 and later)

8.7.3D.1 Definition and applicability

The UE transmitted power absolute accuracy is defined as difference between the UE reported value and the UE transmitted power measured by test system. The reference point for the UE transmitted power shall be the antenna connector of the UE.

The requirements and this test apply to Release 5 and later releases for the FDD UE.

8.7.3D.2 Minimum requirements

This requirement is applicable in CELL_DCH state. The measured quantity is the transmitted power averaged over the longest period (excluding a 25 μ s period either side of any expected composite power change) during which the nominal composite symbol power reaches the maximum during 1 DPCH slot interval.

The normative reference for this requirement is TS 25.133 [2] clause 9.1.6.

8.7.3D.3 Test purpose

The purpose of this test is to verify that for any reported value of UE Transmitted Power in the range specified in table 8.7.3D.5 that the actual UE mean power lies within the range specified in clause 8.7.3D.5.

8.7.3D.4 Method of test

8.7.3D.4.1 Initial conditions

Test environment: normal, TL/VL, TL/VH, TH/VL, TH/VH; see clauses G.2.1 and G.2.2.

Frequencies to be tested: mid range; see clause G.2.4.

- 1) Connect SS to the UE antenna connector as shown in figure A.1.

The test parameters are given in Table 8.7.3D.4.1 and 8.7.3D.4.2 below. In the measurement control information it shall be indicated to the UE that periodic reporting of the UE transmitted power measurement shall be used. The UE measured quantity absolute accuracy is defined in Table 8.7.3D.4.3.

Table 8.7.3D.4.1: General test parameters for UE transmitted power

Parameter	Unit	Value	Comment
DCH parameters		DL Reference Measurement Channel 12.2 kbps	As specified in clause C.3.1
DL-Power Control		Off	

Table 8.7.3D.4.2: Cell Specific parameters for UE transmitted power

Parameter	Unit	Cell 1
CPICH_Ec/lor	dB	-10
PCCPCH_Ec/lor	dB	-12
SCH_Ec/lor	dB	-12
PICH_Ec/lor	dB	-15
DPCH_Ec/lor	dB	-3
OCNS_Ec/lor	dB	-5.2
\hat{I}_{or}/I_{oc}	dB	0
I_{oc}	dBm/3.84 MHz	-70
CPICH_Ec/lo	dB	-13
Propagation Condition		AWGN

Table 8.7.3D.4.3: UE transmitted power requirements

Reported value	Measured quantity value (dBm)	Accuracy (dB) note 1	
UE_TX_POWER_104	33 ≤ to < 34	note 2	
UE_TX_POWER_103	32 ≤ to < 33	note 2	
UE_TX_POWER_102	31 ≤ to < 32	note 2	
...	...		
UE_TX_POWER_096	25 ≤ to < 26	note 2	
UE_TX_POWER_095	24 ≤ to < 25	2.0	-2.0
UE_TX_POWER_094	23 ≤ to < 24	2.0	-2.0
UE_TX_POWER_093	22 ≤ to < 23	2.0	-2.0
UE_TX_POWER_092	21 ≤ to < 22	2.0	-2.0
UE_TX_POWER_091	20 ≤ to < 21	2.5	-2.5
UE_TX_POWER_090	19 ≤ to < 20	3.0	-3.0
UE_TX_POWER_089	18 ≤ to < 19	3.5	-3.5
UE_TX_POWER_088	17 ≤ to < 18	4.0	-4.0
UE_TX_POWER_087	16 ≤ to < 17	4.0	-4.0
UE_TX_POWER_086	15 ≤ to < 16	4.0	-4.0
UE_TX_POWER_085	14 ≤ to < 15	4.0	-4.0
UE_TX_POWER_084	13 ≤ to < 14	4.0*	-4.0 (note 3)
UE_TX_POWER_083	12 ≤ to < 13	4.0*	-4.0 (note 3)
UE_TX_POWER_082	11 ≤ to < 12	4.0*	-4.0 (note 3)
UE_TX_POWER_081	10 ≤ to < 11	note 2	
...	...		
UE_TX_POWER_023	-48 ≤ to < -47	note 2	
UE_TX_POWER_022	-49 ≤ to < -48	note 2	
UE_TX_POWER_021	-50 ≤ to < -49	note 2	
Note 1:	The tolerance is specified for the maximum and minimum measured quantity value (dBm), i.e. MIN(Measured quantity value) + MIN(Accuracy) ≤ UE transmitted Power < Max (Measured quantity value) + MAX(Accuracy)		
Note 2:	No tolerance is specified.		
Note 3:	Applicable to power class 4		

8.7.3D.4.2 Procedure

- 1) A call is set up according to the test procedure specified in TS 34.108 [3] subclause 7.3.2. The RF parameters are set up according to table 8.7.3D.4.1 and 8.7.3D.4.2. Set the UE power and Maximum allowed UL TX power to the maximum power for the UE power class.
- 2) SS shall send continuously during the entire test Up power control commands to the UE.
- 3) SS shall transmit the MEASUREMENT CONTROL message as defined in the specific message contents below.
- 4) Decode the UE Transmitted power reported by the UE in the next available MEASUREMENT REPORT message.
- 5) Measure the mean power of the UE over the longest period (excluding a 25 μs period either side of any expected composite power change) during which the nominal composite symbol power reaches the maximum during one DPCH slot interval.
- 6) Steps 4 and 5 shall be repeated 1000 times.
- 7) Decrease the Maximum allowed UL TX power by 1 dB. The SS shall transmit the PHYSICAL CHANNEL RECONFIGURATION message, as defined in the specific message contents below.
- 8) SS shall wait for the PHYSICAL CHANNEL RECONFIGURATION COMPLETE message from the UE.
- 9) Repeat from step 4) until the Maximum allowed UL TX Power reaches PUEMAX-10.

Specific Message Contents

All messages indicated above shall use the same content as described in default message content in clause 9 of 34.108 [3], with the following exceptions:

MEASUREMENT CONTROL message:

Information Element	Value/Remark
Message Type	
UE information elements	
-RRC transaction identifier	0
-Integrity check info	
-message authentication code	SS calculates the value of MAC-I for this message and writes to this IE. The first/leftmost bit of the bit string contains the most significant bit of the MAC-I.
-RRC message sequence number	SS provides the value of this IE, from its internal counter.
Measurement Information elements	
-Measurement Identity	5
-Measurement Command	SETUP
-CHOICE Measurement type	UE Internal measurement
-UE Internal measurement quantity	
-Measurement quantity	UE Transmitted power
-Filter coefficient	0
-UE Internal reporting quantity	
-UE Transmitted power	TRUE
-CHOICE mode	FDD
-UE Rx-Tx time difference	FALSE
-CHOICE report criteria	Periodical reporting criteria
-Amount of reporting	Infinity
-Reporting interval	250
-Measurement Reporting Mode	
-Measurement Report Transfer Mode	AM RLC
-Periodical Reporting / Event Trigger Reporting Mode	Periodical reporting
-AdditionalMeasurementList	Not Present
Physical channel information elements	
-DPCH compressed mode status info	Not Present

MEASUREMENT REPORT message:

Information Element	Value/remark
Message Type	
Integrity check info	The presence of this IE is dependent on PIXIT statements in TS 34.123-2. If integrity protection is indicated to be active, this IE shall be present with the values of the sub IEs as stated below. Else, this IE and the sub-IEs shall be absent.
- Message authentication code	This IE is checked to see if it is present. The value is compared against the XMAC-I value computed by SS.
- RRC Message sequence number	This IE is checked to see if it is present. The value is used by SS to compute the XMAC-I value.
Measurement identity	5
Measured Results	
- CHOICE Measurement	UE Internal measured results
- Choice mode	FDD
- UE Transmitted power	Checked that this IE is present
- UE Rx-Tx report entries	Checked that this IE is absent
Measured results on RACH	Checked that this IE is absent
Additional measured results	Checked that this IE is absent
Event results	Checked that this IE is absent

PHYSICAL CHANNEL RECONFIGURATION message:

Information Element	Value/Remark	Version
Message Type		
UE Information Elements	0	
-RRC transaction identifier		
-Integrity check info		
-message authentication code	SS calculates the value of MAC-I for this message and writes to this IE. The first/leftmost bit of the bit string contains the most significant bit of the MAC-I.	
-RRC message sequence number	SS provides the value of this IE, from its internal counter.	
-Integrity protection mode info	Not Present	
-Ciphering mode info	Not Present	
-Activation time	Not Present	
-New U-RNTI	Not Present	
-New C-RNTI	Not Present	
-RRC State Indicator	CELL_DCH	
-UTRAN DRX cycle length coefficient	Not Present	
CN Information Elements		
-CN Information info	Not Present	
UTRAN mobility information elements		
-URA identity	Not Present	
RB information elements		
-Downlink counter synchronisation info	Not Present	
PhyCH information elements		
-Frequency info	Not Present	
Uplink radio resources		
-Maximum allowed UL TX power	At the first time this value is set to PUEMAX-1. After the second time this value is decreased with 1 dB from previous value.	
Downlink radio resources		
-CHOICE mode	FDD	
-Downlink PDSCH information	Not Present	
-Downlink information common for all radio links	Not Present	R99 and R4 only
-Downlink information per radio link list	Not Present	

8.7.3D.5 Test requirements

Compare each of the UE transmitted power reports against the following mean power measurement. At least 90% of the mean power measurements for any one value of reported UE transmitted power shall be within the range specified in table 8.7.3D.5.

Table 8.7.3D.5 UE transmitted power test requirements

Reported value	Measured quantity value (dBm)	Accuracy (dB) note 1	
UE_TX_POWER_104	33 ≤ to < 34	note 2	
UE_TX_POWER_103	32 ≤ to < 33	note 2	
UE_TX_POWER_102	31 ≤ to < 32	note 2	
...	...		
UE_TX_POWER_096	25 ≤ to < 26	note 2	
UE_TX_POWER_095	24 ≤ to < 25	2.7	-2.7
UE_TX_POWER_094	23 ≤ to < 24	2.7	-2.7
UE_TX_POWER_093	22 ≤ to < 23	2.7	-2.7
UE_TX_POWER_092	21 ≤ to < 22	2.7	-2.7
UE_TX_POWER_091	20 ≤ to < 21	3.2	-3.2
UE_TX_POWER_090	19 ≤ to < 20	3.7	-3.7
UE_TX_POWER_089	18 ≤ to < 19	4.2	-4.2
UE_TX_POWER_088	17 ≤ to < 18	4.7	-4.7
UE_TX_POWER_087	16 ≤ to < 17	4.7	-4.7
UE_TX_POWER_086	15 ≤ to < 16	4.7	-4.7
UE_TX_POWER_085	14 ≤ to < 15	4.7	-4.7
UE_TX_POWER_084	13 ≤ to < 14	4.7*	-4.7 (note 3)
UE_TX_POWER_083	12 ≤ to < 13	4.7*	-4.7 (note 3)
UE_TX_POWER_082	11 ≤ to < 12	4.7*	-4.7 (note 3)
UE_TX_POWER_081	10 ≤ to < 11	note 2	
...	...		
UE_TX_POWER_023	-48 ≤ to < -47	note 2	
UE_TX_POWER_022	-49 ≤ to < -48	note 2	
UE_TX_POWER_021	-50 ≤ to < -49	note 2	
Note 1: The tolerance is specified for the maximum and minimum measured quantity value (dBm), i.e. $\text{MIN}(\text{Measured quantity value}) + \text{MIN}(\text{Accuracy})$ $\leq \text{UE transmitted Power} < \text{MAX}(\text{Measured quantity value}) + \text{MAX}(\text{Accuracy})$			
Note 2: No tolerance is specified.			
Note 3: Applicable to power class 4			

NOTE 1: If the above Test Requirement differs from the Minimum Requirement then the Test Tolerance applied for this test is non-zero. The Test Tolerance for this test is defined in clause F.2 and the explanation of how the Minimum Requirement has been relaxed by the Test Tolerance is given in clause F.4.

8.7.4 SFN-CFN observed time difference

8.7.4.1 Intra frequency measurement requirement

8.7.4.1.1 Definition and applicability

The intra frequency SFN-CFN observed time difference is defined as the SFN-CFN observed time difference from the active cell to a neighbour cell that is in the same frequency. This measurement is specified in clause 5.1.8 of TS 25.215 [22].

The reference point for the SFN-CFN observed time difference shall be the antenna connector of the UE.

The requirements and this test apply to all types of UTRA for the FDD UE.

8.7.4.1.2 Minimum requirements

The accuracy requirement in table 8.7.4.1.1 is valid under the following conditions:

CPICH_RSCP1,2_{dBm} ≥ -114 dBm for Bands I, IV, VI and X,

CPICH_RSCP1,2_{dBm} ≥ -113 dBm for Band IX,

CPICH_RSCP1,2_{dBm} ≥ -112 dBm for Bands II, V, VII and XI,

CPICH_RSCP1,2_{dBm} ≥ -111 dBm for Band III and VIII.

$$\left| CPICH_RSCP1 \Big|_{in\ dBm} - CPICH_RSCP2 \Big|_{in\ dBm} \right| \leq 20dB$$

$$\left(\frac{I_o}{\hat{I}_{or}} \right) \Big|_{in\ dB} - \left(\frac{CPICH_E_c}{I_{or}} \right) \Big|_{in\ dB} \leq 20dB$$

$$\left(\frac{I_o}{\hat{I}_{or}} \right) \Big|_{in\ dB} - \left(\frac{P - CCPCH_E_c}{I_{or}} \right) \Big|_{in\ dB} \text{ is low enough to ensure successful SFN decoding.}$$

Table 8.7.4.1.1 SFN-CFN observed time difference intra frequency accuracy

Parameter	Unit	Accuracy [chip]	Conditions			
			Io [dBm/3.84 MHz]			
			Band I, IV, VI and X	Band IX	Band II, V, VII and XI	Band III and VIII
SFN-CFN observed time difference	chip	± 1	-94...-50	-93...-50	-92...-50	-91...-50

The normative reference for this requirement is TS 25.133 [2] clauses 9.1.7.1 and A.9.1.4.2.

8.7.4.1.3 Test Purpose

The purpose of this test is to verify that the SFN-CFN observed time difference measurement accuracy is within the specified limits in the clause 8.7.4.1.2. This measurement is for handover timing purposes to identify active cell and neighbour cell time difference.

8.7.4.1.4 Method of test

8.7.4.1.4.1 Initial conditions

Test environment: normal, TL/VL, TL/VH, TH/VL, TH/VH; see clauses G.2.1 and G.2.2.

Frequencies to be tested: mid range; see clause G.2.4.

During the test the timing difference between Cell 1 and 2 can be set to value from 0...9830399 chips.

In this case all cells are in the same frequency. Table 8.7.4.1.2 defines the limits of signal strengths and code powers, where the requirements are applicable.

Table 8.7.4.1.2: SFN-CFN observed time difference Intra frequency test parameters

Parameter		Unit	Test 1		Test 2		Test 3	
			Cell 1	Cell 2	Cell 1	Cell 2	Cell 1	Cell 2
UTRA RF Channel number			Channel 1		Channel 1		Channel 1	
CPICH_Ec/Ior		dB	-10		-10		-10	
PCCPCH_Ec/Ior		dB	-12		-12		-12	
SCH_Ec/Ior		dB	-12		-12		-12	
PICH_Ec/Ior		dB	-15		-15		-15	
DPCH_Ec/Ior		dB	-15		-15		-15	
OCNS_Ec/Ior		dB	-1.11		-1.11		-1.11	
Ior/Ioc		dB	10.5		10.5		10.5	
Ioc		dBm/ 3.84 MHz	$I_o - 13.7 \text{ dB} = I_{oc}$, Note 1		$I_o - 13.7 \text{ dB} = I_{oc}$, Note 1		$I_o - 13.7 \text{ dB} = I_{oc}$, Note 1	
Io	Band I, IV, VI, X	dBm/3.84 MHz	-50		-72		-94	
	Band IX*						-93	
	Band II, V, VII, XI						-92	
	Band III, VIII						-91	
SFN-CFN observed time difference as specified in TS 25.215 [22]		chip	x Note 2					
Propagation condition		-	AWGN		AWGN		AWGN	
NOTE 1: <i>Ioc</i> level shall be adjusted according the total signal power <i>I_o</i> at receiver input and the geometry factor <i>I_o/I_{oc}</i> .								
*) For the UE which supports both Band III and Band IX operating frequencies, the measurement performance requirements for Band III shall apply to the multi-band UE.								
NOTE2: For example, x= 491520 or 9830399. This is a calculated value using parameters "OFF" and "Tm" as specified in TS 25.215 [22].								
Tests shall be done sequentially. Test 1 shall be done first. After test 1 has been executed test parameters for tests 2 and 3 shall be set within 5 seconds so that UE does not loose the Cell 2 in between the tests.								

8.7.4.1.4.2 Procedure

- 1) A call is set up according to the test procedure specified in TS 34.108 [3] subclause 7.3.2. The RF parameters for Test 1 are set up according to table 8.7.4.1.4.
- 2) SS shall transmit MEASUREMENT CONTROL message.
- 3) UE shall transmit periodically MEASUREMENT REPORT message.
- 4) SS shall check "OFF" and "Tm" values in MEASUREMENT REPORT message and calculate SFN-CFN observed time difference value according to the definition in clause 5.1.8 of TS 25.215 [22]. This value shall be compared to the actual SFN-CFN observed time difference value for each MEASUREMENT REPORT message.
- 5) SS shall count the number of MEASUREMENT REPORT messages transmitted by UE. After 1000 MEASUREMENT REPORT messages have been received from UE, the RF parameters are set up according to table 8.7.4.1.4 for Test 2. While RF parameters are being set up, MEASUREMENT REPORT messages from UE are ignored. SS shall wait for additional 1s and ignore the MEASUREMENT REPORT messages during this period. Then, step 4) above is repeated. After further 1000 MEASUREMENT REPORT messages have been received from UE, the RF parameters are set up according to table 8.7.4.1.4 for Test 3. While RF parameters are being set up, MEASUREMENT REPORT messages from UE are ignored. SS shall wait for additional 1s and ignore the MEASUREMENT REPORT messages during this period. Then, step 4) above is repeated.
- 6) After further 1000 MEASUREMENT REPORT messages have been received from UE, the SS shall transmit RRC CONNECTION RELEASE message.
- 7) UE shall transmit RRC CONNECTION RELEASE COMPLETE message.

Specific Message Contents

All messages indicated above shall use the same content as described in the default message content in clause 9 of 34.108 [3], with the following exceptions:

MEASUREMENT CONTROL message for intra frequency measurement

Information Element	Value/Remark
Message Type	
UE information elements	
-RRC transaction identifier	0
-Integrity check info	
-message authentication code	SS calculates the value of MAC-I for this message and writes to this IE. The first/leftmost bit of the bit string contains the most significant bit of the MAC-I.
-RRC message sequence number	SS provides the value of this IE, from its internal counter.
Measurement Information elements	
-Measurement Identity	1
-Measurement Command	Modify
-Measurement Reporting Mode	
- Measurement Report Transfer Mode	Acknowledged mode RLC
- Periodical Reporting / Event Trigger Reporting Mode	Periodical reporting
-Additional measurement list	Not Present
-CHOICE Measurement Type	Intra-frequency measurement
-Intra-frequency measurement	
- Intra-frequency measurement objects list	Not Present
-Intra-frequency measurement quantity	
-Filter coefficient	0
-CHOICE mode	FDD
-Measurement quantity	CPICH RSCP
-Intra-frequency reporting quantity	
-Reporting quantities for active set cells	
-Cell synchronisation information reporting indicator	TRUE
-Cell Identity reporting indicator	TRUE
-CHOICE mode	FDD
-CPICH Ec/N0 reporting indicator	TRUE
-CPICH RSCP reporting indicator	TRUE
-Pathloss reporting indicator	FALSE
-Reporting quantities for monitored set cells	
-Cell synchronisation information reporting indicator	TRUE
-Cell Identity reporting indicator	TRUE
-CHOICE mode	FDD
-CPICH Ec/N0 reporting indicator	TRUE
-CPICH RSCP reporting indicator	TRUE
-Pathloss reporting indicator	FALSE
-Reporting quantities for detected set cells	Not Present
-Reporting cell status	
-CHOICE reported cell	Report all active set cells + cells within monitored set on used frequency
-Maximum number of reported cells	Virtual/active set cells + 2
-Measurement validity	Not Present
-CHOICE <i>report criteria</i>	Periodical reporting criteria
-Amount of reporting	Infinity
-Reporting interval	250 ms
Physical channel information elements	
-DPCH compressed mode status info	Not Present

MEASUREMENT REPORT message for Intra frequency test cases

This message is common for all intra frequency test cases in clause 8.7 and is described in Annex I.

8.7.4.1.5 Test requirements

Table 8.7.4.1.3 SFN-CFN observed time difference intra frequency accuracy

Parameter	Unit	Accuracy [chip]	Conditions			
			Io [dBm/3.84 MHz]			
			Band I, IV, VI, and X	Band IX	Band II, V, VII and XI	Band III, and VIII
SFN-CFN observed time difference	chip	± 1.5	-94...-50	-93...-50	-92...-50	-91...-50

Table 8.7.4.1.4: SFN-CFN observed time difference Intra frequency test parameters

Parameter		Unit	Test 1		Test 2		Test 3	
			Cell 1	Cell 2	Cell 1	Cell 2	Cell 1	Cell 2
UTRA RF Channel number			Channel 1		Channel 1		Channel 1	
CPICH_Ec/Ior		dB	-10		-10		-10	
PCCPCH_Ec/Ior		dB	-12		-12		-12	
SCH_Ec/Ior		dB	-12		-12		-12	
PICH_Ec/Ior		dB	-15		-15		-15	
DPCH_Ec/Ior		dB	-15		-15		-15	
OCNS_Ec/Ior		dB	-1.11		-1.11		-1.11	
Ior/Ioc		dB	10.8		10.8		10.8	
Ioc	Band I, IV, VI, X	dBm/ 3.84 MHz	-65.3		-85.7		-106.7	
	Band IX*						-105.7	
	Band II, V, VII, XI						-104.7	
	Band III, VIII						-103.7	
Io, Note 1	Band I, IV, VI, X	dBm/3.84 MHz	-51.3		-71.7		-92.7	
	Band IX*						-91.7	
	Band II, V, VII, XI						-90.7	
	Band III, VIII						-89.7	
SFN-CFN observed time difference as specified in TS 25.215 [22]		chip	x Note 2					
Propagation condition		-	AWGN		AWGN		AWGN	
NOTE 1: Io level has been calculated from other parameters for information purposes. It is not a settable parameter itself.								
*) For the UE which supports both Band III and Band IX operating frequencies, the measurement performance requirements for Band III shall apply to the multi-band UE.								
NOTE2: For example, x= 491520 or 9830399. This is a calculated value using parameters "OFF" and "Tm" as specified in TS 25.215 [22].								
Tests shall be done sequentially. Test 1 shall be done first. After test 1 has been executed test parameters for tests 2 and 3 shall be set within 5 seconds so that UE does not loose the Cell 2 in between the tests.								

The accuracy of the SFN-CFN observed time difference measurement value calculated from the reported "OFF" and "Tm" values shall meet the requirements in table 8.7.4.1.5.

Table 8.7.4.1.5: SFN-CFN observed time difference measurement accuracy requirements for the reported values

	Test 1	Test 2	Test 3
Lowest reported value	SFN_CFN_TIME (X - 2)	SFN_CFN_TIME (X - 2)	SFN_CFN_TIME (X - 2)
Highest reported value	SFN_CFN_TIME (X + 2)	SFN_CFN_TIME (X + 2)	SFN_CFN_TIME (X + 2)
SFN-CFN_TIME (X) is the reported value for the actual SFN-CFN observed time difference value as defined in table 8.7.4.1.4			

NOTE: If the above Test Requirement differs from the Minimum Requirement then the Test Tolerance applied for this test is non-zero. The Test Tolerance for this test is defined in clause F.2 and the explanation of how the Minimum Requirement has been relaxed by the Test Tolerance is given in clause F.4.

8.7.4.2 Inter frequency measurement requirement

8.7.4.2.1 Definition and applicability

The inter frequency SFN-CFN observed time difference is defined as the SFN-CFN time difference from the active cell to a neighbour cell that is in a different frequency. This measurement is specified in clause 5.1.8 of TS 25.215 [22].

The reference point for the SFN-CFN observed time difference shall be the antenna connector of the UE.

The requirements and this test apply to all types of UTRA for the FDD UE.

8.7.4.2.2 Minimum requirements

The accuracy requirement in table 8.7.4.2.1 is valid under the following conditions:

$CPICH_RSCP1,2|_{dBm} \geq -114$ dBm for Bands I, IV, VI and X,

$CPICH_RSCP1,2|_{dBm} \geq -113$ dBm for Band IX,

$CPICH_RSCP1,2|_{dBm} \geq -112$ dBm for Bands II, V, VII and XI,

$CPICH_RSCP1,2|_{dBm} \geq -111$ dBm for Band III and VIII.

$$\left| CPICH_RSCP1|_{in\ dBm} - CPICH_RSCP2|_{in\ dBm} \right| \leq 20\text{dB}$$

$$\left| Channel\ 1_Io|_{dBm/3.84\ MHz} - Channel\ 2_Io|_{dBm/3.84\ MHz} \right| \leq 20\ dB.$$

$$\left(\frac{I_o}{\hat{I}_{or}} \right)_{in\ dB} - \left(\frac{CPICH - E_c}{I_{or}} \right)_{in\ dB} \leq 20\text{dB}$$

Table 8.7.4.2.1 SFN-CFN observed time difference inter frequency accuracy

Parameter	Unit	Accuracy [chip]	Conditions			
			Io [dBm/3.84 MHz]			
			Band I, IV, VI and X	Band IX	Band II, V, VII and XI	Band III and VIII
SFN-CFN observed time difference	chip	± 1	-94...-50	-93...-50	-92...-50	-91...-50

The normative reference for this requirement is TS 25.133 [2] clauses 9.1.7.2 and A.9.1.4.2.

8.7.4.2.3 Test purpose

The purpose of this test is to verify that the SFN-CFN observed time difference measurement accuracy is within the specified limits in the clause 8.7.4.2.2. This measurement is for handover timing purposes to identify active cell and neighbour cell time difference.

8.7.4.2.4 Method of test

8.7.4.2.4.1 Initial conditions

Test environment: normal, TL/VL, TL/VH, TH/VL, TH/VH; see clauses G.2.1 and G.2.2.

Frequencies to be tested: mid range; see clause G.2.4.

During the test the timing difference between Cell 1 and 2 can be set to value from 0...9830399 chips.

In this test case both cells are in different frequency and compressed mode is applied. The gap length is 7, detailed definition is in clause C.5, set 1 of table C.5.2 except for TGRRC and TGCFN. TGPRC and TGCFN shall set to "Infinity" and "(Current CFN + (256 – TTI/10msec))mod 256". Table 8.7.4.2.2 defines the limits of signal strengths and code powers, where the requirement is applicable.

Table 8.7.4.2.2: SFN-CFN observed time difference Inter frequency tests parameters

Parameter		Unit	Test 1		Test 2		Test 3	
			Cell 1	Cell 2	Cell 1	Cell 2	Cell 1	Cell 2
UTRA RF Channel number			Channel 1	Channel 2	Channel 1	Channel 2	Channel 1	Channel 2
CPICH_Ec/lor		dB	-10		-10		-10	
PCCPCH_Ec/lor		dB	-12		-12		-12	
SCH_Ec/lor		dB	-12		-12		-12	
PICH_Ec/lor		dB	-15		-15		-15	
DPCH_Ec/lor		dB	-15		-15		-15	
OCNS_Ec/lor		dB	-1.11		-1.11		-1.11	
\hat{I}_{or}/loc		dB	10.1		10.1		10.1	
loc		dBm/ 3.84 MHz	$lo - 10.6 \text{ dB} = loc$, Note 1		$lo - 10.6 \text{ dB} = loc$, Note 1		$lo - 10.6 \text{ dB} = loc$, Note 1	
lo	Band I, IV, VI, X	dBm/3.84 MHz	-50		-72		-94	
	Band IX*						-93	
	Band II, V, VII, XI						-92	
	Band III, VIII						-91	
S FN-CFN observed time difference as specified in TS 25.215 [22]		chip	x Note 2					
Propagation condition		-	AWGN		AWGN		AWGN	
NOTE 1: loc level shall be adjusted in each carrier frequency according the total signal power lo at receiver input and the geometry factor \hat{I}_{or}/loc .								
*) For the UE which supports both Band III and Band IX operating frequencies, the measurement performance requirements for Band III shall apply to the multi-band UE.								
NOTE2: For example, $x= 491520$ or 9830399 . This is a calculated value using parameters "OFF" and "Tm" as specified in TS 25.215 [22].								
Tests shall be done sequentially. Test 1 shall be done first. After test 1 has been executed test parameters for tests 2 and 3 shall be set within 5 seconds so that UE does not loose the Cell 2 in between the tests.								

8.7.4.2.4.2 Procedure

- 1) A call is set up according to the test procedure specified in TS 34.108 [3] subclause 7.3.2. The RF parameters for Test 1 are set up according to table 8.7.4.2.4.
- 2) SS shall transmit PHYSICAL CHANNEL RECONFIGURATION message.
- 3) UE shall transmit PHYSICAL CHANNEL RECONFIGURATION COMPLETE message.
- 4) SS shall transmit MEASUREMENT CONTROL message.
- 5) UE shall transmit periodically MEASUREMENT REPORT messages.
- 6) SS shall check "OFF" and "Tm" values in MEASUREMENT REPORT message and calculate SFN-CFN observed time difference value according to the definition in clause 5.1.8 of TS 25.215 [22]. Note that according to TS 25.215 [22] UE is always reporting "OFF" parameter to be zero. This value shall be compared to the actual SFN-CFN observed time difference value for each MEASUREMENT REPORT message taking into account that "OFF" parameter is set to zero.
- 7) SS shall count number of MEASUREMENT REPORT messages transmitted by UE. After 1000 MEASUREMENT REPORT messages have been received from UE, the RF parameters are set up according to table 8.7.4.2.4 for Test 2. While RF parameters are being set up, MEASUREMENT REPORT messages from UE are ignored. SS shall wait for additional 1s and ignore the MEASUREMENT REPORT messages during this period. Then, steps 5) and 6) above are repeated. After further 1000 MEASUREMENT REPORT messages have been received from UE, the RF parameters are set up according to table 8.7.4.2.4 for Test 3. While RF parameters are being set up, MEASUREMENT REPORT messages from UE are ignored. SS shall wait for additional 1s and ignore the MEASUREMENT REPORT messages during this period. Then, steps 5) and 6) above are repeated.
- 8) After further 1000 MEASUREMENT REPORT messages have been received from UE, the SS shall transmit RRC CONNECTION RELEASE message.
- 9) UE shall transmit RRC CONNECTION RELEASE COMPLETE message.

Specific Message Contents

All messages indicated above shall use the same content as described in the default message content in clause 9 of 34.108 [3], with the following exceptions:

PHYSICAL CHANNEL RECONFIGURATION message for inter frequency measurement

Information Element	Value/Remark	Version
Message Type		
UE Information Elements		
-RRC transaction identifier	0	
-Integrity check info		
-message authentication code	SS calculates the value of MAC-I for this message and writes to this IE. The first/ leftmost bit of the bit string contains the most significant bit of the MAC-I.	
-RRC message sequence number	SS provides the value of this IE, from its internal counter.	
-Integrity protection mode info	Not Present	
-Ciphering mode info	Not Present	
-Activation time	Not Present	
-New U-RNTI	Not Present	
-New C-RNTI	Not Present	
-RRC State Indicator	CELL_DCH	
-UTRAN DRX cycle length coefficient	Not Present	
CN Information Elements		
-CN Information info	Not Present	
UTRAN mobility information elements		
-URA identity	Not Present	
RB information elements		
-Downlink counter synchronisation info	Not Present	
PhyCH information elements		
-Frequency info	Not Present	
Uplink radio resources		
-Maximum allowed UL TX power	Not Present	
- CHOICE channel requirement	Not Present	
Downlink radio resources		
-CHOICE mode	FDD	
-Downlink PDSCH information	Not Present	R99 and Rel-4 only
-Downlink information common for all radio links		
-Downlink DPCH info common for all RL	Not Present	
-CHOICE mode	FDD	
-DPCH compressed mode info		
-Transmission gap pattern sequence		
-TGPSI	1	
-TGPS Status Flag	Activate	
-TGCFN	(Current CFN + (256 – TTI/10msec))mod 256	
-Transmission gap pattern sequence		
configuration parameters		
-TGMP	FDD measurement	
-TGPRC	Infinity	
-TGSN	4	
-TGL1	7	
-TGL2	Not Present	
-TGD	UNDEFINED	
-TGPL1	3	
-TGPL2	Not Present	R99 and Rel-4 only
-RPP	Mode 0	
-ITP	Mode 0	
-CHOICE UL/DL mode	UL and DL	
-Downlink compressed mode method	SF/2	
-Uplink compressed mode method	SF/2	
-Downlink frame type	B	
-DeltaSIR1	3.0	
-DeltaSIRafter1	3.0	
-DeltaSIR2	Not Present	
-DeltaSIRafter2	Not Present	
-N Identify abort	Not Present	
-T Reconfirm abort	Not Present	
-TX Diversity Mode	Not Present	
-SSDT information	Not Present	R99 and Rel-4

-Default DPCH Offset Value	Not Present	only
-Downlink information per radio link list		
-Downlink information for each radio link		
-Choice mode	FDD	
-Primary CPICH info		
-Primary scrambling code	100	
-PDSCH with SHO DCH Info	Not Present	R99 and Rel-4 only
-PDSCH code mapping	Not Present	R99 and Rel-4 only
-Downlink DPCH info for each RL		
-CHOICE mode	FDD	
-Primary CPICH usage for channel estimation	Primary CPICH may be used	
-DPCH frame offset	Set to value Default DPCH Offset Value (as currently stored in SS) mod 38400	
-Secondary CPICH info	Not Present	
-DL channelisation code		
-Secondary scrambling code	Not Present	
-Spreading factor	128	
-Code number	96	
-Scrambling code change	No code change	
-TPC combination index	0	
-SSDT Cell Identity	Not Present	R99 and Rel-4 only
-Closed loop timing adjustment mode	Not Present	
-SCCPCH Information for FACH	Not Present	

MEASUREMENT CONTROL message for Inter frequency measurement

Information Element	Value/Remark
Message Type	
UE information elements	
-RRC transaction identifier	0
-Integrity check info	
-message authentication code	SS calculates the value of MAC-I for this message and writes to this IE. The first/leftmost bit of the bit string contains the most significant bit of the MAC-I.
-RRC message sequence number	SS provides the value of this IE, from its internal counter.
Measurement Information elements	
-Measurement Identity	2
-Measurement Command	Setup
-Measurement Reporting Mode	
- Measurement Report Transfer Mode	Acknowledged mode RLC
- Periodical Reporting / Event Trigger Reporting Mode	Periodical reporting
-Additional measurement list	Not Present
-CHOICE Measurement Type	Inter-frequency measurement
-Inter-frequency measurement	
-Inter-frequency cell info list	
-CHOICE Inter-frequency cell removal	Not Present
-New inter-frequency cells	Cell 2 information is included
-Cell for measurement	
-Inter-frequency measurement quantity	Inter-frequency reporting criteria
-CHOICE reporting criteria	
-Filter coefficient	0
-CHOICE mode	FDD
-Measurement quantity for frequency quality estimate	CPICH RSCP
-Inter-frequency reporting quantity	
-UTRA Carrier RSSI	TRUE
-Frequency quality estimate	TRUE
-Non frequency related cell reporting quantities	
-Cell synchronisation information reporting indicator	TRUE
-Cell Identity reporting indicator	TRUE
-CHOICE mode	FDD
-CPICH Ec/N0 reporting indicator	TRUE
-CPICH RSCP reporting indicator	TRUE
-Pathloss reporting indicator	FALSE
-Reporting cell status	
-CHOICE reported cell	Report cells within monitored set on non-used frequency
-Maximum number of reported cells	2
-Measurement validity	Not Present
-Inter-frequency set update	Not Present
-CHOICE report criteria	Periodical reporting criteria
-Amount of reporting	Infinity
-Reporting interval	500 ms
Physical channel information elements	
-DPCH compressed mode status info	Not Present

MEASUREMENT REPORT message for Inter frequency test cases

This message is common for all inter frequency test cases in clause 8.7 and is described in Annex I.

8.7.4.2.5 Test requirements

Table 8.7.4.2.3 SFN-CFN observed time difference inter frequency accuracy

Parameter	Unit	Accuracy [chip]	Conditions			
			Io [dBm/3.84 MHz]			
			Band I, IV, VI and X	Band IX	Band II, V, VII and XI	Band III and VIII
SFN-CFN observed time difference	chip	± 1.5	-94...-50	-93...-50	-92...-50	-91...-50

Table 8.7.4.2.4: SFN-CFN observed time difference Inter frequency tests parameters

Parameter	Unit	Test 1		Test 2		Test 3		
		Cell 1	Cell 2	Cell 1	Cell 2	Cell 1	Cell 2	
UTRA RF Channel number		Channel 1	Channel 2	Channel 1	Channel 2	Channel 1	Channel 2	
CPICH_Ec/lor	dB	-10		-10		-10		
PCCPCH_Ec/lor	dB	-12		-12		-12		
SCH_Ec/lor	dB	-12		-12		-12		
PICH_Ec/lor	dB	-15		-15		-15		
DPCH_Ec/lor	dB	-15		-15		-15		
OCNS_Ec/lor	dB	-1.11		-1.11		-1.11		
lor/loc	dB	10.4		10.4		10.4		
loc	Band I, IV, VI, X	dBm/ 3.84 MHz		-62.1		-82.6		-103.5
	Band IX*							-102.5
	Band II, V, VII, XI							-101.5
	Band III, VIII							-100.5
Io, Note 1	Band I, IV, VI, X	dBm/3.84 MHz		-51.3		-71.8		-92.7
	Band IX*							-91.7
	Band II, V, VII, XI							-90.7
	Band III, VIII							-89.7
SFN-CFN observed time difference as specified in TS 25.215 [22]	chip	x Note 2						
Propagation condition	-	AWGN		AWGN		AWGN		
NOTE 1: Io level has been calculated from other parameters for information purposes. It is not a settable parameter itself.								
*) For the UE which supports both Band III and Band IX operating frequencies, the measurement performance requirements for Band III shall apply to the multi-band UE.								
NOTE2: For example, x= 491520 or 9830399. This is a calculated value using parameters "OFF" and "Tm" as specified in TS 25.215 [22].								
Tests shall be done sequentially. Test 1 shall be done first. After test 1 has been executed test parameters for tests 2 and 3 shall be set within 5 seconds so that UE does not loose the Cell 2 in between the tests.								

The accuracy of the SFN-CFN observed time difference measurement value calculated from the reported "OFF" and "Tm" values shall meet the requirements in table 8.7.4.2.5.

Table 8.7.4.2.5: SFN-CFN observed time difference measurement accuracy requirements for the reported values

	Test 1	Test 2	Test 3
Lowest reported value	SFN_CFN_TIME (X - 2)	SFN_CFN_TIME (X - 2)	SFN_CFN_TIME (X - 2)
Highest reported value	SFN_CFN_TIME (X + 2)	SFN_CFN_TIME (X + 2)	SFN_CFN_TIME (X + 2)
SFN-CFN_TIME (X) is the reported value for the actual SFN-CFN observed time difference value as defined in table 8.7.4.2.4 taking into account that "OFF" parameter is set to zero.			

NOTE: If the above Test Requirement differs from the Minimum Requirement then the Test Tolerance applied for this test is non-zero. The Test Tolerance for this test is defined in clause F.2 and the explanation of how the Minimum Requirement has been relaxed by the Test Tolerance is given in clause F.4.

8.7.5 SFN-SFN observed time difference

8.7.5.1 SFN-SFN observed time difference type 1

8.7.5.1.1 Definition and applicability

This measurement is specified in clause 5.1.9 of TS 25.215 [22]. The reference point for the SFN-SFN observed time difference type 1 shall be the antenna connector of the UE.

The requirements and this test apply to all types of UTRA for the FDD UE.

8.7.5.1.2 Minimum requirements

The accuracy requirement in table 8.7.5.1.1 is valid under the following conditions:

$CPICH_RSCP1,2|_{dBm} \geq -114$ dBm for Bands I, IV, VI and X,

$CPICH_RSCP1,2|_{dBm} \geq -113$ dBm for Band IX,

$CPICH_RSCP1,2|_{dBm} \geq -112$ dBm for Bands II, V, VII and XI,

$CPICH_RSCP1,2|_{dBm} \geq -111$ dBm for Band III and VIII.

$$\left| CPICH_RSCP1|_{in\ dBm} - CPICH_RSCP2|_{in\ dBm} \right| \leq 20\text{dB}$$

$$\left(\frac{I_o}{\hat{I}_{or}} \right)_{in\ dB} - \left(\frac{CPICH - E_c}{I_{or}} \right)_{in\ dB} \leq 20\text{dB}$$

$$\left(\frac{I_o}{\hat{I}_{or}} \right)_{in\ dB} - \left(\frac{P - CCPCH - E_c}{I_{or}} \right)_{in\ dB} \text{ is low enough to ensure successful SFN decoding.}$$

Table 8.7.5.1.1 SFN-SFN observed time difference type 1 measurement accuracy

Parameter	Unit	Accuracy [chip]	Conditions			
			Io [dBm/3.84 MHz]			
			Band I, IV, VI and X	Band IX	Band II, V, VII and XI	Band III and VIII
SFN-SFN observed time difference type1	chip	± 1	-94...-50	-93...-50	-92...-50	-91...-50

The normative reference for this requirement is TS 25.133 [2] clause 9.1.8.1.1 and A.9.1.5.1.2.

8.7.5.1.3 Test purpose

The purpose of this test is to verify that the measurement accuracy of SFN-SFN observed time difference type 1 is within the limit specified in clause 8.7.5.1.2. This measurement is for identifying time difference between two cells.

8.7.5.1.4 Method of test

8.7.5.1.4.1 Initial conditions

Test environment: normal; see clauses G.2.1 and G.2.2.

Frequencies to be tested: mid range; see clause G.2.4.

During the test the timing difference between Cell 1 and 2 can be set to value from 0...9830399 chips.

- 1) Connect SS to the UE antenna connector as shown in figure A.14.

In this case all cells are in the same frequency. Table 8.7.5.1.2 defines the limits of signal strengths and code powers, where the requirements are applicable.

Table 8.7.5.1.2: SFN-SFN observed time difference type 1 Intra frequency test parameters

Parameter		Unit	Test 1		Test 2		Test 3	
			Cell 1	Cell 2	Cell 1	Cell 2	Cell 1	Cell 2
UTRA RF Channel number			Channel 1		Channel 1		Channel 1	
CPICH_Ec/lor		dB	-10		-10		-10	
PCCPCH_Ec/lor		dB	-12		-12		-12	
SCH_Ec/lor		dB	-12		-12		-12	
PICH_Ec/lor		dB	-15		-15		-15	
S-CCPCH_Ec/lor		dB	-12		-12		-12	
OCNS_Ec/lor		dB	-1.29		-1.29		-1.29	
lor/loc		dB	10.5		10.5		10.5	
loc		dBm/ 3.84 MHz	$lo - 13.7 \text{ dB} = loc$, Note 1		$lo - 13.7 \text{ dB} = loc$, Note 1		$lo - 13.7 \text{ dB} = loc$, Note 1	
lo	Band I, IV, VI, X	dBm/3.84 MHz	-50		-72		-94	
	Band IX*						-93	
	Band II, V, VII, XI						-92	
	Band III, VIII						-91	
SFN-SFN observed time difference type 1 as specified in TS 25.215 [22]		chip	x Note 2					
Propagation condition		-	AWGN		AWGN		AWGN	
NOTE 1: <i>loc</i> level shall be adjusted according the total signal power <i>lo</i> at receiver input and the geometry factor \hat{lor}/loc .								
*) For the UE which supports both Band III and Band IX operating frequencies, the measurement performance requirements for Band III shall apply to the multi-band UE.								
NOTE2: For example, x= 491520 or 9830399. This is a calculated value using the parameters "OFF" and "Tm" as specified in TS 25.215 [22].								
Tests shall be done sequentially. Test 1 shall be done first. After test 1 has been executed test parameters for tests 2 and 3 shall be set within 5 seconds so that UE does not loose the Cell 2 in between the tests.								

8.7.5.1.4.2 Procedure

- 1) A call is set up according to the test procedure specified in TS 34.108 [3] subclause 7.3.5. The RF parameters for Test 1 are set up according to table 8.7.5.1.4.
- 2) SS shall transmit MEASUREMENT CONTROL message.
- 3) UE shall transmit periodically MEASUREMENT REPORT messages.
- 4) SS shall check "SFN-SFN observed time difference type 1" value in MEASUREMENT REPORT message. The reported value shall be compared to actual SFN-SFN observed time difference type 1 value for each MEASUREMENT REPORT message.
- 5) SS shall count the number of MEASUREMENT REPORT messages transmitted by UE. After 1000 MEASUREMENT REPORT messages have been received from UE, the RF parameters are set up according to table 8.7.5.1.4 for Test 2. While RF parameters are being set up, MEASUREMENT REPORT messages from UE are ignored. SS shall wait for additional 1s and ignore the MEASUREMENT REPORT messages during this period. Then, step 4) above is repeated. After further 1000 MEASUREMENT REPORT messages have been received from UE, the RF parameters are set up according to table 8.7.5.1.4 for Test 3. While RF parameters are being set up, MEASUREMENT REPORT messages from UE are ignored. SS shall wait for additional 1s and ignore the MEASUREMENT REPORT messages during this period. Then, step 4) above is repeated.
- 6) After further 1000 MEASUREMENT REPORT messages have been received from UE, the SS shall transmit RRC CONNECTION RELEASE message.
- 7) UE shall transmit RRC CONNECTION RELEASE COMPLETE message.

Specific Message Contents

All messages indicated above shall use the same content as described in the default message content in clause 6.1.0b of 34.108 [3] and clause 9 of 34.108 [3], with the following exceptions:

Contents of System Information Block type 11 (FDD) (Step 1):

Information Element	Value/Remark
<ul style="list-style-type: none"> - Intra-frequency measurement system information - Intra-frequency reporting quantity for RACH Reporting - SFN-SFN observed time difference reporting indicator - CHOICE mode - Reporting quantity - Maximum number of reported cells on RACH 	type 1 FDD CPICH RSCP current cell + best neighbour

MEASUREMENT CONTROL message for Traffic Volume measurement (Step 2):

Information Element/Group name	Value/Remark	
Message Type (10.2.17)		
UE information elements <ul style="list-style-type: none"> - RRC transaction identifier - Integrity check info - message authentication code - RRC message sequence number 	0 SS calculates the value of MAC-I for this message and writes to this IE. The first/ leftmost bit of the bit string contains the most significant bit of the MAC-I. SS provides the value of this IE, from its internal counter.	
Measurement Information elements <ul style="list-style-type: none"> - Measurement Identity - Measurement Command (10.3.7.46) - Measurement Reporting Mode (10.3.7.49) - Measurement Report Transfer Mode - Periodical Reporting / Event Trigger Reporting Mode - Additional measurements list (10.3.7.1) 	4 Setup AM RLC Periodical reporting Not Present	
<ul style="list-style-type: none"> - CHOICE <i>Measurement type</i> (10.3.7.68) - Traffic volume measurement Object (10.3.7.70) <ul style="list-style-type: none"> - Traffic volume measurement objects - Uplink transport channel type - Uplink transport channel type - UL Target Transport Channel ID - Traffic volume measurement quantity (10.3.7.71) <ul style="list-style-type: none"> - Measurement quantity - Time Interval to take an average or a variance - Traffic volume reporting quantity (10.3.7.74) - RLC Buffer Payload for each RB - Average of RLC Buffer Payload for each RB - Variance of RLC Buffer Payload for each RB - Measurement validity (10.3.7.51) - CHOICE <i>report criteria</i> (10.3.7.53) <ul style="list-style-type: none"> - Amount of reporting - Reporting interval 	Traffic Volume measurement 1 RACHorCPCH RACH Not Present RLC Buffer Payload Not Present FALSE FALSE FALSE Not Present Periodical reporting criteria Infinity 250 ms	R99 and Rel-4 only Rel-5
Physical channel information elements <ul style="list-style-type: none"> -DPCH compressed mode status info (10.3.6.34) 	Not Present	

MEASUREMENT REPORT message for SFN-SFN observed time difference type 1 test case (Step 3)

Information Element	Value/remark
Message Type	The presence of this IE is dependent on IXIT statements in TS 34.123-2. If integrity protection is indicated to be active, this IE shall be present with the values of the sub IEs as stated below. Else, this IE and the sub-IEs shall be absent.
Integrity check info	
- Message authentication code	This IE is checked to see if it is present. The value is compared against the XMAC-I value computed by SS.
- RRC Message sequence number	This IE is checked to see if it is present. The value is used by SS to compute the XMAC-I value.
Measurement identity	4
Measured Results	Checked that this IE is absent
Measured results on RACH	Checked that this IE is present
- Measurement result for current cell	Checked that this IE is present
- CHOICE mode	FDD
- CHOICE measurement quantity	Checked that this IE is present
- Measurement results for monitored cells	1
- SFN-SFN observed time difference	Checked that this IE is present
- CHOICE Type	Type 1
- CHOICE mode	FDD
- Primary CPICH info	Checked that this IE is present
- Primary scrambling code	150
Additional measured results	Checked that this IE is absent
Event results	Checked that this IE is absent

8.7.5.1.5 Test requirements

Table 8.7.5.1.3 SFN-SFN observed time difference type 1 measurement accuracy

Parameter	Unit	Accuracy [chip]	Conditions			
			Io [dBm/3.84 MHz]			
			Band I, IV, VI and X	Band IX	Band II, V, VII and XI	Band III and VIII
SFN-SFN observed time difference type1	chip	± 1.5	-94...-50	-93...-50	-92...-50	-91...-50

Table 8.7.5.1.4: SFN-SFN observed time difference type 1 Intra frequency test parameters

Parameter		Unit	Test 1		Test 2		Test 3	
			Cell 1	Cell 2	Cell 1	Cell 2	Cell 1	Cell 2
UTRA RF Channel number			Channel 1		Channel 1		Channel 1	
CPICH_Ec/lor		dB	-10		-10		-10	
PCCPCH_Ec/lor		dB	-12		-12		-12	
SCH_Ec/lor		dB	-12		-12		-12	
PICH_Ec/lor		dB	-15		-15		-15	
S-CCPCH_Ec/lor		dB	-12		-12		-12	
OCNS_Ec/lor		dB	-1.29		-1.29		-1.29	
lor/loc		dB	10.8		10.8		10.8	
loc	Band I, IV, VI, X	dBm/ 3.84 MHz	-65.3 dB		-85.7		-106.7	
	Band IX*						-105.7	
	Band II, V, VII, XI						-104.7	
	Band III, VIII						-103.7	
lo, Note 1	Band I, IV, VI, X	dBm/3.84 MHz	-51.3		-71.7		-92.7	
	Band IX*						-91.7	
	Band II, V, VII, XI						-90.7	
	Band III, VIII						-89.7	
SFN-SFN observed time difference type 1 as specified in TS 25.215 [22]		chip	x Note 2					
Propagation condition		-	AWGN		AWGN		AWGN	
NOTE 1: lo level has been calculated from other parameters for information purposes. It is not a settable parameter itself.								
*) For the UE which supports both Band III and Band IX operating frequencies, the measurement performance requirements for Band III shall apply to the multi-band UE.								
NOTE2: For example, x= 491520 or 9830399. This is a calculated value using the parameters "OFF" and "Tm" as specified in TS 25.215 [22].								
Tests shall be done sequentially. Test 1 shall be done first. After test 1 has been executed test parameters for tests 2 and 3 shall be set within 5 seconds so that UE does not loose the Cell 2 in between the tests.								

The reported values for SFN-SFN observed time difference type 1 accuracy shall meet the requirements in table 8.7.5.1.5.

Table 8.7.5.1.5: SFN-SFN observed time difference type 1 measurement accuracy requirements for the reported values

	Test 1	Test 2	Test 3
Lowest reported value	T1_SFN-SFN_TIME_(X - 2)	T1_SFN-SFN_TIME_(X - 2)	T1_SFN-SFN_TIME_(X - 2)
Highest reported value	T1_SFN-SFN_TIME_(X + 2)	T1_SFN-SFN_TIME_(X + 2)	T1_SFN-SFN_TIME_(X + 2)
T1_SFN-SFN_TIME_(X) is the reporting value corresponding to SFN-SFN observed time difference type 1 measured by system simulator			

NOTE: If the above Test Requirement differs from the Minimum Requirement then the Test Tolerance applied for this test is non-zero. The Test Tolerance for this test is defined in clause F.2 and the explanation of how the Minimum Requirement has been relaxed by the Test Tolerance is given in clause F.4.

8.7.5.2 SFN-SFN observed time difference type 2 without IPDL period active

Note: This test case is not complete and there are currently no plans to complete it.

8.7.5.2.1 Definition and applicability

This measurement is specified in clause 5.1.9 of TS 25.215 [22]. The reference point for the SFN-SFN observed time difference type 2 shall be the antenna connector of the UE.

The requirements and this test apply to all types of UTRA for the FDD UE supporting this measurement.

8.7.5.2.2 Minimum requirements

The accuracy requirement in table 8.7.5.2.1 is valid under the following conditions:

$CPICH_RSCP_{1,2}|_{dBm} \geq -114$ dBm for Bands I, IV, VI and X,

$CPICH_RSCP_{1,2}|_{dBm} \geq -113$ dBm for Band IX,

$CPICH_RSCP_{1,2}|_{dBm} \geq -112$ dBm for Bands II, V, VII and XI,

$CPICH_RSCP_{1,2}|_{dBm} \geq -111$ dBm for Band III and VIII.

$$\left| \frac{I_o}{\hat{I}_{or}} \right|_{in\ dB} - \left(\frac{CPICH - E_c}{I_{or}} \right)_{in\ dB} \leq 20dB$$

Table 8.7.5.2.1 SFN-SFN observed time difference type 2 measurement accuracy

Parameter	Unit	Accuracy [chip]	Conditions			
			Io [dBm/3.84 MHz]			
			Band I, IV, VI and X	Band IX	Band II, V, VII and XI	Band III, and VIII
SFN-SFN observed time difference type1	chip	± 0.5	-94...-50	-93...-50	-92...-50	-91...-50

The normative reference for this requirement is TS 25.133 [2] clause 9.1.8.2.1.

8.7.5.2.3 Test purpose and Environment

The purpose of this test is to verify that the SFN-SFN observed time difference type 2 measurement accuracy without IPDL period active is within the limits specified in clause 8.7.5.2.2.

During the test the time difference between Cell 1 and 2 can be set to value from -1279.75 to 1280 chips.

In this case all cells are in the same frequency. Table 8.7.5.2.2 defines the limits of signal strengths and code powers, where the requirements are applicable.

Table 8.7.5.2.2: SFN-SFN observed time difference type 2 Intra frequency test parameters

Parameter		Unit	Cell 1	Cell 2
UTRA RF Channel number			Channel 1	Channel 1
CPICH_Ec/Ior		dB	-10	-10
PCCPCH_Ec/Ior		dB	-12	-12
SCH_Ec/Ior		dB	-12	-12
PICH_Ec/Ior		dB	-15	-15
DPCH_Ec/Ior		dB	-15	-15
OCNS		dB	-1.11	-1.11
\hat{I}_{or}/I_{oc}		dB	10.5	10.5
I_{oc}		dBm/ 3.84 MHz	$I_{oc} - 13.7 \text{ dB} = I_{oc}$, Note 1	$I_{oc} - 13.7 \text{ dB} = I_{oc}$, Note 1
CPICH_Ec/Io, Note 2		dB	-13.2	-13.2
Range 1	I_{oc}	dBm/3.84 MHz	-94...-70 (Band I, IV, VI, X) -93...-70 (Band IX*) -92...-70 (Band II, V, VII, XI) -91...-70 (Band III, VIII)	94...-70 (Band I, IV, VI, X) -93...-70 (Band IX*) -92...-70 (Band II, V, VII, XI) -91...-70 (Band III, VIII)
Range 2			-94...-50 (Band I, IV, VI, X) -93...-50 (Band IX*) -92...-50 (Band II, V, VII, XI) -91...-50 (Band III, VIII)	-94...-50 (Band I, IV, VI, X) -93...-50 (Band IX*) -92...-50 (Band II, V, VII, XI) -91...-50 (Band III, VIII)
Propagation condition		-	AWGN	
NOTE 1: I_{oc} level shall be adjusted according the total signal power spectral density I_{oc} at receiver input and the geometry factor \hat{I}_{or}/I_{oc} .				
*) For the UE which supports both Band III and Band IX operating frequencies, the measurement performance requirements for Band III shall apply to the multi-band UE.				
NOTE 2: I_{oc} and CPICH Ec/Io levels have been calculated from other parameters for information purposes. They are not settable parameters themselves.				

8.7.5.3 SFN-SFN observed time difference type 2 with IPDL period active

Note: This test case is not complete and there are currently no plans to complete it.

8.7.5.3.1 Definition and applicability

This measurement is specified in clause 5.1.9 of TS 25.215 [22]. The reference point for the SFN-SFN observed time difference type 2 shall be the antenna connector of the UE.

The requirements and this test apply to all types of UTRA for the FDD UE supporting IPDL measurements.

8.7.5.3.2 Minimum requirements

The accuracy requirement in table 8.7.5.3.1 is valid under the following conditions:

$CPICH_RSCP_{1,2}|_{dBm} \geq -114 \text{ dBm}$ for Bands I, IV, VI and X,

$CPICH_RSCP_{1,2}|_{dBm} \geq -113 \text{ dBm}$ for Band IX,

$CPICH_RSCP_{1,2}|_{dBm} \geq -112 \text{ dBm}$ for Bands II, V, VII and XI,

$CPICH_RSCP_{1,2}|_{dBm} \geq -111 \text{ dBm}$ for Band III and VIII.

$$\left| \frac{I_{oc}}{\hat{I}_{or}} \right|_{in \text{ dB}} - \left(\frac{CPICH - E_c}{I_{or}} \right)_{in \text{ dB}} \leq 20 \text{ dB}$$

Additionally the accuracy requirement in table 8.7.5.3.1 is also valid for neighbour cells for which the following conditions apply to during idle periods provided idle periods have a length of 1 slot:

$CPICH_RSCP_{x,y}|_{dBm} \geq -114 \text{ dBm}$.

$$\left. \frac{I_{o_idle_period}}{(\hat{I}_{or})} \right|_{in\ dB} - \left(\frac{CPICH_Ec}{I_{or}} \right) \Big|_{in\ dB} \leq 20dB,$$

where x and y represent cells measured using idle periods and $I_{o_idle_period}$ is the total received power during the idle period.

NOTE: Additional general conditions are needed for the requirements in table 8.7.5.3.1 to be valid.

Table 8.7.5.3.1 SFN-SFN observed time difference type 2 measurement accuracy

Parameter	Unit	Accuracy [chip]	Conditions			
			Io [dBm/3.84 MHz]			
			Band I, IV, VI and X	Band IX	Band II, V, VII and XI	Band III and VIII
SFN-SFN observed time difference type1	chip	± 0.5	-94...-50	-93...-50	-92...-50	-91...-50

The normative reference for this requirement is TS 25.133 [2] clause 9.1.8.2.2.

8.7.5.3.3 Test purpose and Environment

The purpose of this test is to verify that the SFN-SFN observed time difference type 2 measurement accuracy without IPDL period active is within the limits specified in clause 8.7.5.2.2.

During the test the time difference between Cell 1 and 2 shall be set according to the assistance data defined in table 8.7.5.3.3.

In this case all cells are in the same frequency. Table 8.7.5.3.2 defines the limits of signal strengths and code powers, where the requirements are applicable.

Table 8.7.5.3.2: SFN-SFN observed time difference type 2 Intra frequency test parameters

Parameter	Unit	Cell 1		Cell 2	
		No idle period	Idle period in Cell 1	No idle period	Idle period in Cell 1
UTRA RF Channel number		Channel 1	Channel 1	Channel 1	Channel 1
CPICH_Ec/Ior	dB	-10	-10	-10	-10
PCCPCH_Ec/Ior	dB	-12	-12	-12	-12
SCH_Ec/Ior	dB	-12	-12	-12	-12
PICH_Ec/Ior	dB	-15	-15	-15	-15
DPCH_Ec/Ior	dB	-15	-15	-	-
OCNS	dB	-1.11	-1.11	-0.94	-0.94
Ior/Ioc	dB	10.5	-24.5	-6	-6
Ioc	dBm/ 3.84 MHz	-80			
Io, Note 1	dBm/3.84 MHz	-69.04	-79.01	-69.04	-79.01
CPICH_Ec/Io, Note 1	dB	-10.46	-35.49	-26.96	-16.99
Propagation condition	-	AWGN			
NOTE 1: Io and CPICH Ec/Io levels have been calculated from other parameters for information purposes. They are is not settable parameters themselves.					

When verifying the SFN-SFN observed time difference type 2 intra frequency measurement accuracy with IPDL period active the idle period parameters in table 8.7.5.3.3 shall be used.

Table 8.7.5.3.3: SFN-SFN observed time difference type 2 Intra frequency test parameters

Parameter	Unit	Cell 1
Search Window Size	Chips	80
IP_Status	-	Continuous
IP_Spacing	Frames	10
IP_Length	Symbols	10
IP_Offset	frame	NA
Seed	integer	13
Burst_Start		NA
Burst_Length		NA
Burst_Freq		NA

8.7.6 UE Rx-Tx time difference

8.7.6.1 UE Rx-Tx time difference type 1

8.7.6.1.1 Definition and applicability

The UE Rx-Tx time difference is defined as the time difference between the UE uplink DPCCCH/DPDCH frame transmission and the first detected path (in time) of the downlink DPCH frame from the measured radio link. The reference point of the UE Rx-Tx time difference shall be the antenna connector of the UE. This measurement is specified in clause 5.1.10 of TS 25.215.

The requirements and this test apply to all types of UTRA for the FDD UE.

8.7.6.1.2 Minimum requirements

Table 8.7.6.1.1 UE Rx-Tx time difference type 1 measurement accuracy

Parameter	Unit	Accuracy [chip]	Conditions			
			I _o [dBm/3.84MHz]			
			Band I, IV, VI and X	Band IX	Band II, V, VII and XI	Band III and VIII
UE RX-TX time difference	chip	± 1.5	-94...-50	-93...-50	-92...-50	-91...-50

The normative reference for this requirement is TS 25.133 [2] clause 9.1.9.1.1 and A.9.1.6.1.2.

8.7.6.1.3 Test purpose

The purpose of this test is to verify that the measurement accuracy of Rx-Tx time difference is within the limit specified in clause 8.7.6.1.2. This measurement is used for call setup purposes to compensate propagation delay of DL and UL.

8.7.6.1.4 Method of test

8.7.6.1.4.1 Initial conditions

Test environment: normal; see clauses G.2.1 and G.2.2.

Frequencies to be tested: mid range; see clause G.2.4.

- 1) Connect SS to the UE antenna connector as shown in figure A.1

Table 8.7.6.1.2: UE Rx-Tx time difference type 1 intra frequency test parameters

Parameter		Unit	Test 1	Test 2	Test 3
			Cell 1	Cell 1	Cell 1
UTRA RF Channel number			Channel 1	Channel 1	Channel 1
CPICH_Ec/lor		dB	-10	-10	-10
PCCPCH_Ec/lor		dB	-12	-12	-12
SCH_Ec/lor		dB	-12	-12	-12
PICH_Ec/lor		dB	-15	-15	-15
DPCH_Ec/lor		dB	-15	-15	-15
OCNS_Ec/lor		dB	-1.11	-1.11	-1.11
\hat{I}_{or}/I_{oc}		dB	10.5	10.5	10.5
I_{oc}		dBm/ 3.84 MHz	$I_{oc} - 10.9 \text{ dB} = I_{oc}$, Note 1	$I_{oc} - 10.9 \text{ dB} = I_{oc}$, Note 1	$I_{oc} - 10.9 \text{ dB} = I_{oc}$, Note 1
I_{o}	Band I, IV, VI, X	dBm/3.84 MHz	-94	-72	-50
	Band IX*		-93		
	Band II, V, VII, XI		-92		
	Band III, VIII		-91		
Propagation condition		-	AWGN	AWGN	AWGN
NOTE 1: I_{oc} level shall be adjusted according the total signal power spectral density I_{o} at receiver input and the geometry factor \hat{I}_{or}/I_{oc} .					
*) For the UE which supports both Band III and Band IX operating frequencies, the measurement performance requirements for Band III shall apply to the multi-band UE.					

8.7.6.1.4.2 Procedure

- 1) A call is set up according to the test procedure specified in TS 34.108 [3] subclause 7.3.2. The RF parameters are set up according to table 8.7.6.1.4 for Test 1.
- 2) SS shall transmit MEASUREMENT CONTROL message.
- 3) UE shall transmit periodically MEASUREMENT REPORT message.
- 4) SS shall check "UE Rx-Tx time difference type 1" value in MEASUREMENT REPORT message. The reported value shall be compared to actual UE Rx-Tx time difference value for each MEASUREMENT REPORT message. The comparison should be repeated 1000 times.
- 5) The RF parameters are set up according table 8.7.6.1.4 for Test 2. While RF parameters are being set up, MEASUREMENT REPORT messages from UE are ignored. SS shall wait for additional 1s and ignore the MEASUREMENT REPORT messages during this period.
- 6) SS shall check "UE Rx-Tx time difference type 1" value in MEASUREMENT REPORT message. The reported value shall be compared to actual UE Rx-Tx time difference value for each MEASUREMENT REPORT message. The comparison should be repeated 1000 times.
- 7) The RF parameters are set up according table 8.7.6.1.4 for Test 3. While RF parameters are being set up, MEASUREMENT REPORT messages from UE are ignored. SS shall wait for additional 1s and ignore the MEASUREMENT REPORT messages during this period.
- 8) SS shall check "UE Rx-Tx time difference type 1" value in MEASUREMENT REPORT message. The reported value shall be compared to actual UE Rx-Tx time difference value for each MEASUREMENT REPORT message. The comparison should be repeated 1000 times.
- 9) SS shall transmit RRC CONNECTION RELEASE message.

Specific Message Contents

All messages indicated above shall use the same content as described in default message content in clause 9 of 34.108 [3], with the following exceptions:

MEASUREMENT CONTROL message for Intra frequency measurement (Step 2):

Information Element	Value/Remark
Message Type UE information elements -RRC transaction identifier -Integrity check info -message authentication code -RRC message sequence number	0 SS calculates the value of MAC-I for this message and writes to this IE. The first/leftmost bit of the bit string contains the most significant bit of the MAC-I. SS provides the value of this IE, from its internal counter.
Measurement Information elements -Measurement Identity -Measurement Command - Additional measurements list -Measurement Reporting Mode -Measurement Report Transfer Mode -Periodical Reporting / Event Trigger Reporting Mode -CHOICE Measurement type -UE Internal measurement quantity -CHOICE mode -Measurement quantity -Filter coefficient -UE Internal reporting quantity -UE Transmitted power -CHOICE mode -UE Rx-Tx time difference -CHOICE report criteria -Amount of reporting -Reporting interval	5 SETUP Not Present AM RLC Periodical reporting UE Internal measurement FDD UE Rx-Tx time difference 0 FALSE FDD TRUE Periodical reporting criteria Infinity 250
Physical channel information elements -DPCH compressed mode status info	Not Present

MEASUREMENT REPORT message

Information Element	Value/remark
Message Type Integrity check info - Message authentication code - RRC Message sequence number Measurement identity Measured Results - CHOICE Measurement - Choice mode - UE Transmitted power - UE Rx-Tx report entries - Primary CPICH info - Primary scrambling code - UE Rx-Tx time difference type 1 Measured results on RACH Additional measured results Event results	The presence of this IE is dependent on IXIT statements in TS 34.123-2. If integrity protection is indicated to be active, this IE shall be present with the values of the sub IEs as stated below. Else, this IE and the sub-IEs shall be absent. This IE is checked to see if it is present. The value is compared against the XMAC-I value computed by SS. This IE is checked to see if it is present. The value is used by SS to compute the XMAC-I value. 5 UE Internal measured results FDD Checked that this IE is absent Checked that this IE is present 100 Checked that this IE is present Checked that this IE is absent Checked that this IE is absent Checked that this IE is absent

8.7.6.1.5 Test requirements

Table 8.7.6.1.3 UE Rx-Tx time difference type 1 measurement accuracy

Parameter	Unit	Accuracy [chip]	Conditions			
			Io [dBm/3.84MHz]			
			Band I, IV, VI and X	Band IX	Band II, V, VII and XI	Band III and VIII
UE RX-TX time difference	chip	± 2.0	-94...-50	-93...-50	-92...-50	-91...-50

Table 8.7.6.1.4: UE Rx-Tx time difference type 1 intra frequency test parameters

Parameter		Unit	Test 1 Cell 1	Test 2 Cell 1	Test 3 Cell 1
UTRA RF Channel number			Channel 1	Channel 1	Channel 1
CPICH_Ec/Ior		dB	-10	-10	-10
PCCPCH_Ec/Ior		dB	-12	-12	-12
SCH_Ec/Ior		dB	-12	-12	-12
PICH_Ec/Ior		dB	-15	-15	-15
DPCH_Ec/Ior		dB	-15	-15	-15
OCNS_Ec/Ior		dB	-1.11	-1.11	-1.11
Ior/Ioc		dB	10.5	10.5	10.5
Ioc	Band I, IV, VI, X	dBm/ 3.84 MHz	-103.6	-82.9	-62.2
	Band IX*		-102.6		
	Band II, V, VII, XI		-101.6		
	Band III, VIII		-100.6		
Io	Band I, IV, VI, X	dBm/3.84 MHz	-92.7	-72	-51.3
	Band IX*		-91.7		
	Band II, V, VII, XI		-90.7		
	Band III, VIII		-89.7		
Propagation condition		-	AWGN	AWGN	AWGN

NOTE 1: Ioc level shall be adjusted according the total signal power spectral density Io at receiver input and the geometry factor Ior/Ioc.
 *) For the UE which supports both Band III and Band IX operating frequencies, the measurement performance requirements for Band III shall apply to the multi-band UE.

The reported values for UE Rx-Tx time difference accuracy shall meet the requirements in table 8.7.6.1.5.

Table 8.7.6.1.5: UE Tx-Rx time difference type 1 measurement accuracy requirements for the reported values

	Test 1	Test 2	Test 3
Lowest reported value	RX-TX_TIME_(X - 2)	RX-TX_TIME_(X - 2)	RX-TX_TIME_(X - 2)
Highest reported value	RX-TX_TIME_(X + 2)	RX-TX_TIME_(X + 2)	RX-TX_TIME_(X + 2)

RX-TX_TIME_(X) is the reporting value corresponding to UE Rx-Tx time difference measured by system simulator

NOTE: If the above Test Requirement differs from the Minimum Requirement then the Test Tolerance applied for this test is non-zero. The Test Tolerance for this test is defined in clause F.2 and the explanation of how the Minimum Requirement has been relaxed by the Test Tolerance is given in clause F.4.

8.7.6.2 UE Rx-Tx time difference type 2

Note: This test case is not complete and there are currently no plans to complete it.

8.7.6.2.1 Definition and applicability

The UE Rx-Tx time difference is defined as the time difference between the UE uplink DPCCCH/DPDCH frame transmission and the first detected path (in time) of the downlink DPCH frame from the measured radio link. The reference point of the UE Rx-Tx time difference shall be the antenna connector of the UE. This measurement is specified in clause 5.1.10 of TS 25.215.

The requirements and this test apply to all types of UTRA for the FDD UE supporting this measurement.

8.7.6.2.2 Minimum requirements

Table 8.7.6.2.1 UE Rx-Tx time difference type 2 measurement accuracy

Parameter	Unit	Accuracy [chip]	Conditions			
			Io [dBm/3.84MHz]			
			Band I, IV, VI and X	Band IX	Band II, V, VII and XI	Band III and VIII
UE RX-TX time difference	chip	± 1.0	-94...-50	-93...-50	-92...-50	-91...-50

The normative reference for this requirement is TS 25.133 [2] clause 9.1.9.2.1.

8.7.6.2.3 Test purpose

The purpose of this test is to verify that the measurement accuracy of Rx-Tx time difference type 2 is within the limit specified in clause 8.7.6.2.2.

The connection is started using cell 1, then cell 2 is added to the active set so that cell 1 is the timing reference. During the test the downlink DPCH time difference between Cell 1 and 2 can be set to any value from -148 to 148 chips.

Table 8.7.6.2.2 defines the limits of signal strengths and code powers, where the requirements are applicable.

Table 8.7.6.2.2 UE Rx-Tx time difference type 2 measurement parameters

Parameter	Unit	Cell 1	Cell 2
UTRA RF Channel number		Channel 1	Channel 1
Downlink DPCH timing	Chips	Timing reference	From reference timing -148 to reference timing+148
CPICH_Ec/Ior	dB	-10	-10
PCCPCH_Ec/Ior	dB	-12	-12
SCH_Ec/Ior	dB	-12	-12
PICH_Ec/Ior	dB	-15	-15
DPCH_Ec/Ior	dB	-15	-15
OCNS	dB	-1.11	-1.11
\hat{I} or/Ioc	dB	10.5	10.5
Ioc	dBm/ 3.84 MHz	Io -10.9 dB = Ioc, Note 1	Io-13.7 dB = Ioc, Note 1
Io	dBm/ 3.84 MHz	-94...-50 (Band I, IV, VI, X) -93...-50 (Band IX*) -92...-50 (Band II, V, VII, XI) -91...-50 (Band III, VIII)	-94...-50 (Band I, IV, VI, X) -93...-50 (Band IX*) -92...-50 (Band II, V, VII, XI) -91...-50 (Band III, VIII)
Propagation condition	-	AWGN	
NOTE 1: Ioc level shall be adjusted according the total signal power spectral density Io at receiver input and the geometry factor \hat{I} or/Ioc.			
*) For the UE which supports both Band III and Band IX operating frequencies, the measurement performance requirements for Band III shall apply to the multi-band UE.			

8.7.7 Observed time difference to GSM cell (R99 and Rel-4 only)

Void

8.7.8 P-CCPCH RSCP

8.7.8.1 Absolute measurement accuracy

8.7.8.1.1 Definition and applicability

The absolute accuracy of P-CCPCH RSCP is defined as the P-CCPCH RSCP measured in an UTRA TDD cell on one frequency compared to the actual P-CCPCH RSCP power of that cell on the same frequency.

The requirements and this test apply only to UE supporting both UTRA FDD and UTRA TDD for Release 99 and Release 4 only.

8.7.8.1.2 Minimum Requirements

8.7.8.1.2.1 3.84Mcps TDD option

The accuracy requirement in table 8.7.8.1.1 is valid under the following conditions:

$$P\text{-CCPCH_RSCP} \geq -102 \text{ dBm},$$

$$\left(\frac{I_o}{\hat{I}_{or}} \right)_{in \text{ dB}} - \left(\frac{P - CCPCH - E_c}{I_{or}} \right)_{in \text{ dB}} \leq 8 \text{ dB}$$

Table 8.7.8.1.1: P-CCPCH RSCP inter frequency absolute accuracy

Parameter	Unit	Accuracy [dB]		Conditions
		Normal conditions	Extreme conditions	Io [dBm/3.84 MHz]
P-CCPCH_RSCP	dBm	± 6	± 9	-94...-70
	dBm	± 8	± 11	-70...-50

8.7.8.1.2.2 1.28Mcps TDD option

The accuracy requirement in table 9.31A is valid under the following conditions:

$$P\text{-CCPCH RSCP} \geq -102 \text{ dBm}$$

$$P\text{-CCPCH } E_c/I_o \geq -8 \text{ dB}$$

Table 8.7.8.1.1A: P-CCPCH RSCP inter frequency absolute accuracy

Parameter	Unit	Accuracy [dB]		Conditions
		Normal conditions	Extreme conditions	Io [dBm/1.28 MHz]
P-CCPCH_RSCP	dBm	± 6	± 9	-94...-70
	dBm	± 8	± 11	-70...-50

The normative reference for this requirement is TS 25.133 [2] clauses 9.1.11.1 and A.9.1.8.

8.7.8.1.3 Test purpose

The purpose of this test is to verify that the P-CCPCH RSCP absolute measurement accuracy is within the specified limits.

8.7.8.1.4 Method of test

8.7.8.1.4.1 Initial conditions

8.7.8.1.4.1.1 3.84Mcps TDD option

Test environment: normal, TL/VL, TL/VH, TH/VL, TH/VH; see clauses G.2.1 and G.2.2.

Frequencies to be tested: mid range; see clause G.2.4.

In this case both cells are on different frequencies. Cell 1 is a UTRA FDD cell and cell 2 is a 3.84Mcps TDD cell. The second Beacon timeslot shall be provided for cell 2 in timeslot 8. Compressed mode as specified in TS 25.101 [1] section A.5, set 3 of table A.22, is applied. TGPRC and TGCFN shall be set to "Infinity" and "(Current CFN + (256 – TTI/10msec)) mod 256". P-CCPCH RSCP inter frequency absolute accuracy requirements are tested by using test parameters in Table 8.7.8.1.2.

Table 8.7.8.1.2: P-CCPCH RSCP inter frequency tests parameters

Parameter	Unit	Test 1		Test 2	
		Cell 1	Cell 2	Cell 1	Cell 2
DL timeslot number		n.a.	0 8	n.a.	0 8
UTRA RF Channel number		Channel 2	Channel 1	Channel 2	Channel 1
CPICH_Ec/lor	dB	-10	n.a.	-10	n.a.
P-CCPCH_Ec/lor	dB	-12	-3 n.a.	-12	-3 n.a.
SCH_Ec/lor	dB	-12	-9	-12	-9
SCH_t _{offset}		n.a.	5	n.a.	5
PICH_Ec/lor	dB	-15	n.a. -3	-15	n.a. -3
DPCH_Ec/lor	dB	-15	n.a.	-15	n.a.
OCNS_Ec/lor	dB	-1.11	-3.12	-1.11	-3.12
loc	dBm/ 3.84 MHz	-60	-57.7	-84	-84.7
lor/loc	dB	9.54	7	0	3
P-CCPCH RSCP, Note 1	dBm	n.a.	-53.7 n.a.	n.a.	-84.7 n.a.
CPICH RSCP, Note 1	dBm	-60.46	n.a.	-94	n.a.
lo, Note 1	dBm/3.84 MHz	-50	-50	-81	-80
Propagation condition	-	AWGN		AWGN	
Note 1: P-CCPCH RSCP, CPICH RSCP and lo levels have been calculated from other parameters for information purposes. They are not settable parameters themselves.					
Note that the transmit energy per PN chip for the SCH is averaged over the 256 chip duration when the SCH is present in the time slot.					
Tests shall be done sequentially. Test 1 shall be done first. After test 1 has been executed, test parameters for test 2 shall be set within 5 seconds so that the UE does not lose the Cell 2 in between the test.					

8.7.8.1.4.1.2 1.28Mcps TDD option

Test environment: normal, TL/VL, TL/VH, TH/VL, TH/VH; see clauses G.2.1 and G.2.2.

Frequencies to be tested: mid range; see clause G.2.4.

In this case both cells are on different frequencies. Cell 1 is a UTRA FDD cell and cell 2 is a 1.28McpsTDD cell. The second Beacon timeslot shall be provided for cell 2 in timeslot 2. Compressed mode as specified in TS 25.101 [1] section A.5, set 3 of table A.22, is applied. TGPRC and TGCFN shall be set to "Infinity" and "(Current CFN + (256 – TTI/10msec)) mod 256". P-CCPCH RSCP inter frequency absolute accuracy requirements are tested by using test parameters in Table 8.7.8.1.2A.

Table 8.7.8.1.2A: P-CCPCH RSCP inter frequency tests parameters

Parameter	Unit	Test 1			Test 2		
		Cell 1	Cell 2		Cell 1	Cell 2	
DL timeslot number		n.a.	0	DwPTS	n.a.	0	DwPTS
UTRA RF Channel number		Channel 2	Channel 1		Channel 2	Channel 1	
CPICH_Ec/lor	dB	-10	n.a.		-10	n.a.	
P-CCPCH_Ec/lor	dB	-12	-3		-12	-3	
DwPCH_Ec/lor	dB	n.a.		0	n.a.		0
PICH_Ec/lor	dB	-15	n.a.	n.a.	-15	n.a.	n.a.
DPCH_Ec/lor	dB	-15	n.a.	n.a.	-15	n.a.	n.a.
OCNS_Ec/lor	dB	-1.11	-3		-1.11	-3	
loc		-60 dBm/ 3.84 MHz	-57.7 dBm/1.28 MHz		-84 dBm/ 3.84 MHz	-84.7 dBm/1.28 MHz	
lor/loc	dB	9.54	7		0	3	
P-CCPCH RSCP, Note 1	dBm	n.a.	-53.7		n.a.	-84.7	
CPICH RSCP, Note 1	dBm	-60.46	n.a.		-94	n.a.	
Io, Note 1		-50 dBm/ 3.84 MHz	-50 dBm/1.28 MHz		-81 dBm/ 3.84 MHz	-80 dBm/1.28 MHz	
Propagation condition	-	AWGN			AWGN		
Note 1: P-CCPCH RSCP, CPICH RSCP and Io levels have been calculated from other parameters for information purposes. They are not settable parameters themselves.							
Tests shall be done sequentially. Test 1 shall be done first. After test 1 has been executed, test parameters for test 2 shall be set within 5 seconds so that the UE does not lose the Cell 2 in between the test.							

1) A call is set up according to the test procedure specified in TS 34.108 [3] clause 7.3.2. The RF parameters for Test 1 are set up according to table 8.7.8.1.2.

8.7.8.1.4.2 Procedure

- 1) SS shall transmit the PHYSICAL CHANNEL RECONFIGURATION message.
- 2) UE shall transmit the PHYSICAL CHANNEL RECONFIGURATION COMPLETE message.
- 3) SS shall transmit the MEASUREMENT CONTROL message.
- 4) UE shall transmit periodically MEASUREMENT REPORT messages.
- 5) SS shall check P-CCPCH RSCP values of Cell 2 in the MEASUREMENT REPORT messages. P-CCPCH RSCP power level of Cell 2 reported by the UE shall be compared to the actually set P-CCPCH RSCP value of Cell 2 for each MEASUREMENT REPORT message.
- 6) SS shall count number of MEASUREMENT REPORT messages transmitted by UE. After 1000 MEASUREMENT REPORT messages have been received from UE, the RF parameters are set up according to table 8.7.8.1.2 for Test 2. While RF parameters are being set up, MEASUREMENT REPORT messages from UE are ignored. SS shall wait for additional 1s and ignore the MEASUREMENT REPORT messages during this period. Then, steps 4) and 5) above are repeated.
- 7) After further 1000 MEASUREMENT REPORT messages have been received from UE, the SS shall transmit RRC CONNECTION RELEASE message.
- 8) UE shall transmit RRC CONNECTION RELEASE COMPLETE message.

Specific Message Contents

All messages indicated above shall use the same content as described in the default message content in clause 9 of 34.108 [3] and in Annex I, with the following exceptions:

PHYSICAL CHANNEL RECONFIGURATION message for inter frequency measurement (Step 1):

Information Element	Value/Remark	Revision
Message Type		
UE Information Elements		
-RRC transaction identifier	0	
-Integrity check info		
-message authentication code	SS calculates the value of MAC-I for this message and writes to this IE. The first/ leftmost bit of the bit string contains the most significant bit of the MAC-I.	
-RRC message sequence number	SS provides the value of this IE, from its internal counter.	
-Integrity protection mode info	Not Present	
-Ciphering mode info	Not Present	
-Activation time	Not Present	
-New U-RNTI	Not Present	
-New C-RNTI	Not Present	
-RRC State Indicator	CELL_DCH	
-UTRAN DRX cycle length coefficient	Not Present	
CN Information Elements		
-CN Information info	Not Present	
UTRAN mobility information elements		
-URA identity	Not Present	
RB information elements		
-Downlink counter synchronisation info	Not Present	
PhyCH information elements		
-Frequency info	Not Present	
Uplink radio resources		
-Maximum allowed UL TX power	Not Present	
- CHOICE channel requirement	Not Present	
Downlink radio resources		
-CHOICE mode	FDD	
-Downlink PDSCH information	Not Present	R99 and Rel-4 only
-Downlink information common for all radio links		
-Downlink DPCH info common for all RL	Not Present	
-CHOICE mode	FDD	
-DPCH compressed mode info		
-Transmission gap pattern sequence		
-TGPSI	1	
-TGPS Status Flag	Activate	
-TGCFN	(Current CFN + (256 – TTI/10msec))mod 256	
-Transmission gap pattern sequence		
configuration parameters		
-TGMP	TDD measurement	
-TGPRC	Infinity	
-TGSN	10	
-TGL1	10	
-TGL2	Not Present	
-TGD	UNDEFINED	
-TGPL1	11	
-TGPL2	Not Present	R99 and Rel-4 only
-RPP	Mode 0	
-ITP	Mode 0	
-CHOICE UL/DL mode	UL and DL	
-Downlink compressed mode method	Puncturing	
-Uplink compressed mode method	SF/2	
-Downlink frame type	A	
-DeltaSIR1	3.0	
-DeltaSIRafter1	3.0	
-DeltaSIR2	Not Present	
-DeltaSIRafter2	Not Present	
-N Identify abort	Not Present	
-T Reconfirm abort	Not Present	
-TX Diversity Mode	Not Present	
-SSDT information	Not Present	R99 and Rel-4

-Default DPCH Offset Value	Not Present	only
-Downlink information per radio link list		
-Downlink information for each radio link		
-Choice mode	FDD	
-Primary CPICH info		
-Primary scrambling code	100	
-PDSCH with SHO DCH Info	Not Present	R99 and Rel-4 only
-PDSCH code mapping	Not Present	R99 and Rel-4 only
-Downlink DPCH info for each RL		
-CHOICE mode	FDD	
-Primary CPICH usage for channel estimation	Primary CPICH may be used	
-DPCH frame offset	Set to value Default DPCH Offset Value (as currently stored in SS) mod 38400	
-Secondary CPICH info	Not Present	
-DL channelisation code		
-Secondary scrambling code	Not Present	
-Spreading factor	128	
-Code number	96	
-Scrambling code change	No code change	
-TPC combination index	0	
-SSDT Cell Identity	Not Present	R99 and Rel-4 only
-Closed loop timing adjustment mode	Not Present	
-SCCPCH Information for FACH	Not Present	

MEASUREMENT CONTROL message for inter frequency measurement (Step 3):

Information Element	Value/Remark
Message Type	
UE information elements	
-RRC transaction identifier	0
-Integrity check info	
-message authentication code	SS calculates the value of MAC-I for this message and writes to this IE. The first/leftmost bit of the bit string contains the most significant bit of the MAC-I.
-RRC message sequence number	SS provides the value of this IE, from its internal counter.
Measurement Information elements	
-Measurement Identity	2
-Measurement Command	Setup
-Measurement Reporting Mode	
- Measurement Report Transfer Mode	Acknowledged mode RLC
- Periodical Reporting / Event Trigger Reporting Mode	Periodical reporting
-Additional measurement list	Not Present
-CHOICE Measurement Type	Inter-frequency measurement
-Inter-frequency measurement	
-Inter-frequency cell info list	
-CHOICE Inter-frequency cell removal	Not Present
-New inter-frequency cells	Cell 2 information is included.
-Cell for measurement	Not Present
-Inter-frequency measurement quantity	
-CHOICE reporting criteria	Inter-frequency reporting criteria
-Filter coefficient	0
-CHOICE mode	TDD
-Measurement quantity for frequency quality estimate	Primary CCPCH RSCP
-Inter-frequency reporting quantity	
-UTRA Carrier RSSI	FALSE
-Frequency quality estimate	TRUE
-Non frequency related cell reporting quantities	
-Cell synchronisation information reporting indicator	FALSE
-Cell Identity reporting indicator	
-CHOICE mode	FALSE
-Timeslot ISCP reporting indicator	TDD
-Proposed TGSN Reporting required	FALSE
-Primary CCPCH RSCP reporting indicator	FALSE
-Pathloss reporting indicator	TRUE
-Reporting cell status	FALSE
-CHOICE reported cell	Report cells within monitored set on non-used frequency
-Maximum number of reported cells	2
-Measurement validity	Not Present
-Inter-frequency set update	Not Present
-CHOICE report criteria	Periodical reporting criteria
-Amount of reporting	Infinity
-Reporting interval	500 ms
Physical channel information elements	
-DPCH compressed mode status info	Not Present

8.7.8.1.5 Test requirements

The PCCPCH RSCP measurement accuracy shall meet the requirements in clause 8.7.8.1.2.

NOTE: If the above Test Requirement differs from the Minimum Requirement then the Test Tolerance applied for this test is non-zero. The Test Tolerance for this test is defined in clause F.2 and the explanation of how the Minimum Requirement has been relaxed by the Test Tolerance is given in clause F.4.

8.7.9 UE Transmission Power Headroom

8.7.9.1 Definition and applicability

The accuracy requirements for the UE transmission power headroom depends on the total power transmitted by the UE as defined in the functionality in section 9.2.5.3.2 of TS 25.321[13], section 9.1.13.4 of TS 25.133 [2] and section 5.1.14 of TS 25.215 [22]. The requirements and this test apply to Release 6 and later releases for all types of UTRA for the FDD UE that support E-DCH and HSDPA.

8.7.9.2 Minimum Requirements

The UE transmission power headroom (UPH) is defined in section 5.1.14 of TS 25.215 [22] as the ratio of the maximum UE transmission power and the corresponding DPCCCH code power, and shall be calculated as following:

$$UPH = P_{\max,tx} / P_{DPCCCH}$$

where:

$P_{\max,tx}$ = min {Maximum allowed UL TX Power, P_{\max} } is the UE maximum transmission power;

Maximum allowed UL TX Power is set by UTRAN and defined in [8];

P_{\max} is the UE nominal maximum output power according to the UE power class and specified in [1] table 6.1;

P_{DPCCCH} is the transmitted code power on DPCCCH.

The accuracy requirements for UE transmission power headroom depends on the total power transmitted by the UE. Table 8.7.9.1 defines the accuracy of the measured quantity as defined in section 9.1.13.4 of TS 25.133 [2].

Table 8.7.9.1: UPH reporting accuracy

Total UE output power value (dBm)	UPH reporting accuracy(dB) (note 1)
25<= total output power <34	note 2
24<= total output power <25	±2.0
23<= total output power <24	±2.0
22<= total output power <23	±2.0
21<= total output power <22	±2.0
20<= total output power < 21	±2.5
19<= total output power <20	±3.0
18<= total output power <19	±3.5
17<= total output power <18	±4.0
16<= total output power <17	±4.0
15<= total output power <16	±4.0
14<= total output power <15	±4.0
13<= total output power <14	±4.0 (power class 4) ±6.0 (power class 3)
12<= total output power <13	±4.0 (power class 4) ±6.0 (power class 3)
11<= total output power <12	±4.0 (power class 4) ±6.0 (power class 3)
-50<= total output power <11	±6.0
Note 1 : UPH reporting accuracy is the difference between the UPH reported by the UE and the actual uplink power headroom	
Note 2 : No tolerance is specified.	

8.7.9.3 Test purpose

The purpose of this test case is to verify that the UE transmission power headroom measurement report accuracy is within the specified limits defined in section 9.1.13.4 of 25.133 [2] shown in table 8.7.9.1.

8.7.9.4 Method of test

8.7.9.4.1 Initial conditions

Test environment: normal, TL/VL, TL/VH, TH/VL, TH/VH; see clauses G.2.1 and G.2.2.

Frequencies to be tested: mid range; see clause G.2.4.

- 1) Connect the SS (node B emulator) to the UE antenna connector as shown in figure A.1.
- 2) The beta factors for E-DPCCH & HS-DPCCH, Reference E-TFCI index, and E-DCH configurations are set as in table 8.7.9.2.

Table 8.7.9.2: General test parameters for UE transmission power headroom

Parameter	Unit	Value	Comment
DL DCH configuration		DL Reference Measurement Channel 12.2 kbps	As specified in Annex C.3.1 of the present document
DL configuration		DL Fixed Reference Channel (FRC H-Set 1, QPSK version)	As specified in Annex C.8.1.1 of the present document
E-DCH TTI	ms	10	
E-DCH configuration		10 ms TTI E-DCH Transport Block Size Table 0 according to TS 25.321 [13] annex B.3.	
DL Power Control		Off	
Active cell		Cell 1	
β_{ec}/β_c		5/15	
β_{ed_ref}/β_c		5/15	
A _{hs}		5/15	$\Delta ACK = \Delta NACK = \Delta CQI$
Reference E-TFCI index		0 as per Table 0 according to TS 25.321 [13] annex B.3.	

- 3) The power levels and cell specific parameters are set as in table 8.7.9.3.

Table 8.7.9.3: Cell Specific parameters for UE transmission power headroom

Parameter	Unit	Cell 1
CPICH_Ec/I _{or}	dB	-10
PCCPCH_Ec/I _{or}	dB	-12
SCH_Ec/I _{or}	dB	-12
PICH_Ec/I _{or}	dB	-15
DPCH_Ec/I _{or}	dB	-10
HS-SCCH_Ec/I _{or}	dB	-8
HS-PDSCH_Ec/I _{or}	dB	-3
E-AGCH_Ec/I _{or}	dB	DTX'd
E-HICH_Ec/I _{or}	dB	DTX'd
E-RGCH_Ec/I _{or}	dB	DTX'd
OCNS	dB	Note 1
I _{or}	dBm/3.84 MHz	-70
Note 1: The power of the OCNS channel that is added shall make the total power from the cell to be equal to I _{or} .		

- 4) The UE is switched on.
- 5) An E-DCH call is set up according to TS 34.108 [3] 7.3.9 with the following exceptions in the RADIO BEARER SETUP message. These exceptions are derived from Table 8.7.9.2, and in addition allow the beta values to be set and each UL physical channel to be at constant power during the measurement.

Table 8.7.9.4 Contents of RADIO BEARER SETUP message: AM or UM (E-DCH and HSDPA)

Information Element	Value/Remark
Uplink DPCH info <ul style="list-style-type: none"> - Power Control Algorithm - Δ_{ACK} - Δ_{NACK} - Ack-Nack repetition factor 	Algorithm 2 0, giving $A_{hs} = 5/15$ 0, giving $A_{hs} = 5/15$ 3 (required for continuous HS-DPCCH signal)
E-DCH info <ul style="list-style-type: none"> - E-DPCCH info - E-DPCCH/DPCCH power offset - E-DPDCH info - Reference E-TFCIs - Reference E-TFCI - Reference E-TFCI PO - Scheduling Information Configuration - Periodicity for Scheduling Info – no grant 	Uplink DPCH info 0, giving $A_{ec} = 5/15$ 1 E-TFCI 0 0, giving $A_{ed_ref} = 5/15$ 10 ms
Downlink HS-PDSCH Information <ul style="list-style-type: none"> - Measurement Feedback Info <ul style="list-style-type: none"> - CQI Feedback cycle, k - CQI repetition factor - Δ_{CQI} 	4 ms 2 (required for continuous HS-DPCCH signal) 0, giving $A_{hs} = 5/15$

8.7.9.4.2 Test procedure

- 1) The Scheduling Information configuration for the E-DCH indicates to the UE that it shall periodically report Scheduling Information, which contains UPH measurement every E-DCH TTI. During the test the system simulator shall not send any scheduling grant to the UE, and therefore the UE will not send any payload data on the E-DCH.
- 2) The SS shall set the UE DPCCH power to be between -11.1 dBm and -8 dBm for a power class 3 UE, or between -14.1 dBm and -11dBm for a power class 4 UE by using uplink power control.
- 3) The SS measures both the power transmitted by the UE on DPCCH and the total output power of the UE every time slot. The SS averages both the DPCCH output power and total output power of the UE over 100 ms.
- 4) The SS estimates the UE transmission power headroom as the difference between the maximum allowed uplink transmit power (P_{max}) and the average DPCCH power measured in step 3.
- 5) The SS notes the UE transmission power headroom value reported in the Scheduling Information.
- 6) The SS calculates the difference between the UE transmission power headroom value estimated in step 4 and the reported UE transmission power headroom noted in step 5. The SS notes this as the UE transmission power headroom accuracy, and compares it to the applicable limit according to the total output power measured in step 3.
- 7) If the UE transmission power headroom accuracy exceeds the value in Table 8.7.9.5 count a bad result, otherwise a good result with respect to the actually set TX power.
- 8) Repeat steps 3 to 7 in order to collect more good or bad results for the currently set power level. Continue the repetition, until statistical significance according to Annex F.6.2.8 is achieved.
- 9) The SS sends 5 up TPC commands at the frame boundary to bring the Tx power of the UE up by a nominal 1 dB step, then alternate UP/DOWN to maintain constant Tx power.
- 10) Repeat steps 3 through 9 and note the UE transmission power headroom accuracy for each UE total power value until the UE stops reporting UPH or does not give lower UPH values. If the lowest reported UPH is $UE_POWER_HEADROOM_8$ or higher for a power class 3 UE, or $UE_POWER_HEADROOM_7$ or higher for a power class 4 UE, then count a bad result.

8.7.9.5 Test requirements

The UE transmission power headroom measurement report accuracy recorded in steps 6, 9 and 10 above shall meet the requirements in table 8.7.9.5. The rate of correct measurements observed during repeated tests shall be at least 90%. To

pass the test, the UE transmission power headroom accuracy for each power level in the reporting range must pass. Once a power level is passed, no more results need be collected on this power level.

Table 8.7.9.5: Test requirement for UPH reporting accuracy

Total UE output power value (dBm)	UPH reporting accuracy(dB) (note 1)
25<= total output power <34	note 2
24<= total output power <25	±2.8
23<= total output power <24	±2.8
22<= total output power <23	±2.8
21<= total output power <22	±2.8
20<= total output power < 21	±3.3
19<= total output power <20	±3.8
18<= total output power <19	±4.3
17<= total output power <18	±4.8
16<= total output power <17	±4.8
15<= total output power <16	±4.8
14<= total output power <15	±4.8
13<= total output power <14	±4.8 (power class 4) ±6.8 (power class 3)
12<= total output power <13	±4.8 (power class 4) ±6.8 (power class 3)
11<= total output power <12	±4.8 (power class 4) ±6.8 (power class 3)
-50<= total output power <11	±6.8
Note 1: UPH reporting accuracy is the difference between the UPH reported by the UE and the actual uplink power headroom	
Note 2: No tolerance is specified.	

NOTE1: If the above Test Requirement differs from the Minimum Requirement then the Test Tolerance applied for this test is non-zero. The Test Tolerance for this test is defined in clause F.2 and the explanation of how the Minimum Requirement has been relaxed by the Test Tolerance is given in clause F.4.

9 Performance requirements for HSDPA

9.1 General

The performance requirements for the UE in this clause are specified for the measurement channels specified in Annex C, the propagation conditions specified in Annex D and the Down link Physical channels specified in Annex E. Unless stated otherwise, DL power control is OFF.

Unless otherwise stated the performance requirements are specified at the antenna connector of the UE. For UE(s) with more than one receive antenna connector the fading of the signals and the AWGN signals applied to each receiver antenna connector shall be uncorrelated. The levels of the test signal applied to each of the antenna connectors shall be as defined in the respective sections below.

A UE with one antenna connector may also fulfill the enhanced performance requirements Type 1 and Type 3. The levels of the test signal are applied to the single antenna connector as defined in the respective sections below.

When DCCH has been configured on downlink DCH then DCCH Data shall be continuously transmitted on downlink DCH during the measurement period. When there is no signalling to transmit on downlink DCCH then dummy DCCH transmission as described in Annex C.9 shall be used.

When DTCH has been configured on downlink DCH then DTCH Data shall be continuously transmitted on downlink DCH during the measurement period.

The MAC headers on HS-DSCH shall be according to Annex C.9A.

The common RF test conditions of Performance requirements are defined in clause E.5, and each test conditions in clause 9 should refer to clause E.5. Individual test conditions are defined in the paragraph of each test.

All throughput measurements in clause 9 shall be performed according to the general rules for statistical testing in Annex F.6.3.

Unless otherwise stated, the UE output power for the tests shall be greater than -10 dBm.

The requirement for a FDD UE that support HSDPA shall be tested according to the declared UE HS-DSCH category. For Release 6 and later UEs that support either the optional Type 1 or the Type 2 enhanced performance requirement, the UE shall be tested according to this enhanced performance requirement as well. For Release 7 and later UEs that support optional Type 3 enhanced performance requirement, the UE shall be tested according to this enhanced performance requirement as well.

9.1.1 Definition of Additive White Gaussian Noise (AWGN) Interferer

See clause D.1.1.

9.2 Demodulation of HS-DSCH (Fixed Reference Channel)

The minimum performance requirement for a particular UE belonging to certain HS-DSCH category are determined according to Table 9.2.1. The performance requirements for a particular UE belonging to certain HS-DSCH category and supporting the optional enhanced performance requirements type 1 are determined according to Table 9.2.2. The performance requirements for a particular UE belonging to HS-DSCH categories 7 or 8 and supporting the optional enhanced performance requirements type 2 are determined according to Table 9.2.3. The performance requirements for a particular UE belonging to HS-DSCH categories 7 or 8 and supporting the optional enhanced performance requirements type 3 are determined according to Table 9.2.3A.

Table 9.2.1: FRC for minimum performance requirements for different HS-DSCH categories

HS-DSCH category	Corresponding requirement		
	Single Link	Open Loop Diversity	Closed Loop Diversity
Category 1	H-Set 1	H-Set 1	H-Set 1
Category 2	H-Set 1	H-Set 1	H-Set 1
Category 3	H-Set 2	H-Set 2	H-Set 2
Category 4	H-Set 2	H-Set 2	H-Set 2
Category 5	H-Set 3	H-Set 3	H-Set 3
Category 6	H-Set 3	H-Set 3	H-Set 3
Category 7 (Note 1)	H-Set 6, H-Set 3	H-Set 3	H-Set 3
Category 8 (Note 1)	H-Set 6, H-Set 3	H-Set 3	H-Set 3
Category 11	H-Set 4	H-Set 4	H-Set 4
Category 12	H-Set 5	H-Set 5	H-Set 5

Note 1: Single link minimum performance requirements for Categories 7 and 8 in Pedestrian A with $\hat{I}_{or}/I_{oc}=10\text{dB}$ are set according to H-Set 6. Requirements in other conditions are according to H-Set 3.

Note 2: For UE supporting the minimum performance requirements for HS-DSCH the minimum requirements for HS-SCCH detection for single link are determined in Table 9.4.1.2 and for open loop transmit diversity in Table 9.4.2.2.

Table 9.2.2: FRC for enhanced performance requirements type 1 for different HS-DSCH categories

HS-DSCH category	Corresponding requirement		
	Single Link	Open Loop Diversity	Closed Loop Diversity
Category 1	H-Set 1	H-Set 1	H-Set 1
Category 2	H-Set 1	H-Set 1	H-Set 1
Category 3	H-Set 2	H-Set 2	H-Set 2
Category 4	H-Set 2	H-Set 2	H-Set 2
Category 5	H-Set 3	H-Set 3	H-Set 3
Category 6	H-Set 3	H-Set 3	H-Set 3
Category 7 (Note 1)	H-Set 6, H-Set 3	H-Set 3	H-Set 3
Category 8 (Note 1)	H-Set 6, H-Set 3	H-Set 3	H-Set 3

Note 1: Single link enhanced performance requirements type 1 for Categories 7 and 8 in Pedestrian A with $\hat{I}_{or}/I_{oc}=10\text{dB}$ are set according to H-Set 6. Requirements in other conditions are according to H-Set 3.

Note 2: For UE supporting the enhanced performance requirements type 1 for HS-DSCH the requirements for HS-SCCH detection for single link are determined in Table 9.4.1A.2 and for open loop transmit diversity in Table 9.4.2A.2.

Table 9.2.3: FRC for enhanced performance requirements type 2 for different HS-DSCH categories

HS-DSCH category	Corresponding requirement		
	Single Link (Note 1)	Open Loop Diversity (Note 2)	Closed Loop Diversity (Note 3)
Category 7	H-Set 6, H-Set 3	H-Set 3	H-Set 6, H-Set 3
Category 8	H-Set 6, H-Set 3	H-Set 3	H-Set 6, H-Set 3

Note 1: Single link enhanced performance requirements type 2 for Categories 7 and 8 with $\hat{I}_{or}/I_{oc}=10\text{dB}$ are set according to H-Set 6. Requirements in other conditions are according to H-Set 3 minimum performance requirements.

Note 2: Open loop transmit diversity requirements are set according to H-Set 3 minimum performance requirements.

Note 3: Closed loop transmit diversity enhanced performance requirements type 2 for Categories 7 and 8 in Pedestrian B 3km/h with $\hat{I}_{or}/I_{oc}=10\text{dB}$ and $E_c/I_{or}=-3\text{dB}$ are set according to H-Set 6. Requirements in other conditions are set according to H-Set 3 minimum performance requirements.

Note 4: For UE supporting the enhanced performance requirements type 2 for HS-DSCH the minimum requirements for HS-SCCH detection for single link are determined in Table 9.4.1.2 and for open loop transmit diversity in Table 9.4.2.2.

Table 9.2.3A: FRC for enhanced performance requirements type 3 for different HS-DSCH categories

HS-DSCH category	Corresponding requirement		
	Single Link (Note 1)	Open Loop Diversity (Note 2)	Closed Loop Diversity (Note 3)
Category 7	H-Set 6, H-Set 3	H-Set 3	H-Set 3
Category 8	H-Set 6, H-Set 3	H-Set 3	H-Set 3
Note 1	Single link enhanced performance requirements type 3 for Categories 7 and 8 with $\hat{I}_{or}/I_{oc}=10\text{dB}$ and $\hat{I}_{or}/I_{oc}=5\text{dB}$ are set according to H-Set 6. Requirements in other conditions are according to H-Set 3 type1 enhanced performance requirements.		
Note 2	Open loop transmit diversity requirements are set according to H-Set 3 type1 enhanced performance requirements.		
Note 3	Closed loop transmit diversity requirements are set according to H-Set 3 type1 enhanced performance requirements.		
Note 4	For UE supporting the enhanced performance requirements type 3 for HS-DSCH the requirements for HS-SCCH detection for single link are determined in Table 9.4.1A.2 and for open loop transmit diversity in Table 9.4.2A.2.		

During the Fixed Reference Channel tests the behaviour of the Node-B emulator in response to the ACK/NACK signalling field of the HS-DPCCH is specified in Table 9.2.4:

Table 9.2.4: Node-B Emulator Behaviour in response to ACK/NACK/DTX

HS-DPCCH ACK/NACK Field State	Node-B Emulator Behaviour
ACK	ACK: new transmission using 1 st redundancy and constellation version (RV)
NACK	NACK: retransmission using the next RV (up to the maximum permitted number or RV's)
DTX	DTX: retransmission using the RV previously transmitted to the same H-ARQ process

NOTE: Performance requirements in this section assume a sufficient power allocation to HS-SCCH_1 so that probability of reporting DTX is very low.

The reference for this requirement is TS 25.101 [1] clauses 9.2.

9.2.1 Single Link Performance

The test cases in the following sections 9.2.1A to 9.2.1F define the Single Link Performance tests for the different H-Sets for the different HS-DSCH Categories as defined in tables 9.2.1, 9.2.2 and 9.2.3.

9.2.1A Single Link Performance - QPSK/16QAM, Fixed Reference Channel (FRC) H-Set 1/2/3

9.2.1A.1 Definition and applicability

The receiver single link performance of the High Speed Physical Downlink Shared Channel (HS-DSCH) in different multi-path fading environments are determined by the information bit throughput R.

The requirements and this test apply to Release 5 and later releases for all types of UTRA for the FDD UE that support HSDPA UE capability categories 1 to 6.

9.2.1A.2 Minimum requirements

Requirements for a particular UE belonging to certain HS-DSCH category are determined according to the relevant part of Table 9.2.1.

The requirements are specified in terms of minimum information bit throughput R for the DL reference channels H-set 1/2/3 specified in Annex C.8.1.1, C.8.1.2 and C.8.1.3 respectively, with the addition of the relevant parameters in Tables 9.2.1A.1 and 9.2.1A.3 plus the downlink physical channel setup according to table E.5.1.

Using this configuration the throughput shall meet or exceed the minimum requirements specified in tables 9.2.1A.2 and 9.2.1A.4.

Table 9.2.1A.1: Test Parameters for Testing QPSK FRCs H-Set 1/H-Set 2/H-Set 3

Parameter	Unit	Test 1	Test 2	Test 3	Test 4
Phase reference	dBm/3.84 MHz	P-CPICH			
I_{oc}		-60			
Redundancy and constellation version coding sequence		{0,2,5,6}			
Maximum number of HARQ transmission		4			
Note: The HS-SCCH-1 and HS-PDSCH shall be transmitted continuously with constant power. HS-SCCH-1 shall only use the identity of the UE under test for those TTI intended for the UE.					

Table 9.2.1A.2: Minimum requirement QPSK, Fixed Reference Channel (FRC) H-Set 1/2/3

Test Number	Propagation Conditions	Reference value		
		HS-PDSCH E_c / I_{or} (dB)	T-put R (kbps) * $\hat{I}_{or} / I_{oc} = 0$ dB	T-put R (kbps) * $\hat{I}_{or} / I_{oc} = 10$ dB
1	PA3	-6	65	309
		-3	N/A	423
2	PB3	-6	23	181
		-3	138	287
3	VA30	-6	22	190
		-3	142	295
4	VA120	-6	13	181
		-3	140	275
* Notes: 1) The reference value R is for the Fixed Reference Channel (FRC) H-Set 1 2) For Fixed Reference Channel (FRC) H-Set 2 the reference values for R should be scaled (multiplied by 1.5 and rounding to the nearest integer t-put in kbps, where values of $i+1/2$ are rounded up to $i+1$, i integer) 3) For Fixed Reference Channel (FRC) H-Set 3 the reference values for R should be scaled (multiplied by 3 and rounding to the nearest integer t-put in kbps, where values of $i+1/2$ are rounded up to $i+1$, i integer)				

Table 9.2.1A.3: Test Parameters for Testing 16QAM FRCs H-Set 1/H-Set 2/H-Set 3

Parameter	Unit	Test 1	Test 2	Test 3	Test 4
Phase reference	dBm/3.84 MHz	P-CPICH			
I_{oc}		-60			
Redundancy and constellation version coding sequence		{6,2,1,5}			
Maximum number of HARQ transmission		4			
Note: The HS-SCCH-1 and HS-PDSCH shall be transmitted continuously with constant power. HS-SCCH-1 shall only use the identity of the UE under test for those TTI intended for the UE.					

Table 9.2.1A.4: Minimum requirement 16QAM, Fixed Reference Channel (FRC) H-Set 1/2/3

Test Number	Propagation Conditions	Reference value	
		HS-PDSCH E_c / I_{or} (dB)	T-put R (kbps) * $\hat{I}_{or} / I_{oc} = 10$ dB
1	PA3	-6	198
		-3	368
2	PB3	-6	34
		-3	219
3	VA30	-6	47
		-3	214
4	VA120	-6	28
		-3	167
* Notes: 1)The reference value R is for the Fixed Reference Channel (FRC) H-Set 1 2) For Fixed Reference Channel (FRC) H-Set 2 the reference values for R should be scaled (multiplied by 1.5 and rounding to the nearest integer t-put in kbps, where values of $i+1/2$ are rounded up to $i+1$, i integer) 3) For Fixed Reference Channel (FRC) H-Set 3 the reference values for R should be scaled (multiplied by 3 and rounding to the nearest integer t-put in kbps, where values of $i+1/2$ are rounded up to $i+1$, i integer)			

The reference for this requirement is TS 25.101 [1] clauses 9.2.1.1 and 9.2.1.2.

9.2.1A.3 Test purpose

To verify the ability of the receiver to receive a predefined test signal, representing a multi-path fading channel with information bit throughput R not falling below a specified value. The test stresses the multicode reception and channel decoding with incremental redundancy.

9.2.1A.4 Method of test

9.2.1A.4.1 Initial conditions

Test environment: normal; see clauses G.2.1 and G.2.2.

Frequencies to be tested: mid range; see clause G.2.4.

- 1) Connect the SS (node B emulator) and fader and AWGN noise source to the UE antenna connector as shown in figure A.10.
- 2) Set up an HSDPA call with looping back 12.2kbps RMC according to TS 34.108 [3] clause 7.3.6 with levels according to table E.5.0.
- 3) Set the node B emulator behaviour according to table 9.2.4. Set the test parameters for tests 1-4 according to tables 9.2.1A.1 and 9.2.1A.3 and levels according to tables 9.2.1A.5 to 9.2.1A.8 as appropriate. The configuration of the downlink channels is defined in table E.5.1.
- 4) The information bit data shall be pseudo random and not repeated before 10 different information bit payload blocks are processed. (e.g. Fixed reference Channel Definition H-set 1 (16 QAM): The information bit payload block is 4664 bits long. Hence the PRBS sequence must be at least $4664 * 10$ bits long.) Use a PRBS from ITU-T O.153 Ref [27]
- 5) The SS shall not time the transmission freely. It shall time the transmission strictly according to the reference measurement channels: i.e. Process number i is continued exactly after 6 TTIs.
- 6) Setup the fading simulator with fading conditions as described in table D.2.2.1.A

9.2.1A.4.2 Procedure

- 1) Once the HSDPA connection is setup, change levels according to Tables E.5.6 to E.5.8B as specified by table E.5.9 and start transmitting HSDPA Data.
- 2) For all relevant propagation conditions, for all relevant I_{oc} levels, for all relevant E_c/I_{or} , for all relevant \hat{I}_{or}/I_{oc} , for all relevant H-sets in tables 9.2.1A.5 to 9.2.1A.8 count the number of NACK, ACK and statDTX on the UL

HS-DPCCH during the test interval and decide pass or fail according to Annex F.6.3 tables F.6.3.5.2.1 and F.6.3.5.2.2.

9.2.1A.5 Test Requirements

Tables 9.2.1A.5 to 9.2.1A.8 define the primary level settings including test tolerance for all relevant throughput tests. The pass / fail decision for throughput is done according to Annex F.6.3.

Tables E.5.6 to E.5.8B define the secondary and subsequently ranked level settings including test tolerance. As those level settings are not uniform for the throughput tests in this clause, Table E.5.9 indicates which levels are applied, when the primary level settings (E_c/I_{or} and I_{or}/I_{oc}) and propagation conditions (PA3, PB3, VA30, VA 120) vary.

Table 9.2.1A.5: Test Parameters for Testing QPSK FRCs H-Set 1/H-Set 2/H-Set 3

Parameter	Unit	Test 1	Test 2	Test 3	Test 4
Phase reference		P-CPICH			
I_{oc}	dBm/3.84 MHz	-60 (no test tolerance applied)			

Table 9.2.1A.6: Test requirement QPSK, Fixed Reference Channel (FRC) H-Set 1/2/3

Test Number	Propagation Conditions	Reference value		
		HS-PDSCH E_c/I_{or} (dB)	T-put R (kbps) * $\hat{I}_{or}/I_{oc} = 0.6$ dB	T-put R (kbps) * $\hat{I}_{or}/I_{oc} = 10.6$ dB
1	PA3	-5.9	65	309
		-2.9	N/A	423
2	PB3	-5.9	23	181
		-2.9	138	287
3	VA30	-5.9	22	190
		-2.9	142	295
4	VA120	-5.9	13	181
		-2.9	140	275

* Notes: 1) The reference value R is for the Fixed Reference Channel (FRC) H-Set 1
2) For Fixed Reference Channel (FRC) H-Set 2 the reference values for R should be scaled (multiplied by 1.5 and rounding to the nearest integer t-put in kbps, where values of $i+1/2$ are rounded up to $i+1$, i integer)
3) For Fixed Reference Channel (FRC) H-Set 3 the reference values for R should be scaled (multiplied by 3 and rounding to the nearest integer t-put in kbps, where values of $i+1/2$ are rounded up to $i+1$, i integer)

Table 9.2.1A.7: Test Parameters for Testing 16QAM FRCs H-Set 1/H-Set 2/H-Set 3

Parameter	Unit	Test 1	Test 2	Test 3	Test 4
Phase reference		P-CPICH			
I_{oc}	dBm/3.84 MHz	-60 (no test tolerance applied)			

Table 9.2.1A.8: Test requirement 16QAM, Fixed Reference Channel (FRC) H-Set 1/2/3

Test Number	Propagation Conditions	Reference value	
		HS-PDSCH E_c / I_{or} (dB)	T-put R (kbps) * $\hat{I}_{or} / I_{oc} = 10.6$ dB
1	PA3	-5.9	198
		-2.9	368
2	PB3	-5.9	34
		-2.9	219
3	VA30	-5.9	47
		-2.9	214
4	VA120	-5.9	28
		-2.9	167

* Notes: 1) The reference value R is for the Fixed Reference Channel (FRC) H-Set 1
2) For Fixed Reference Channel (FRC) H-Set 2 the reference values for R should be scaled (multiplied by 1.5 and rounding to the nearest integer t-put in kbps, where values of $i+1/2$ are rounded up to $i+1$, i integer)
3) For Fixed Reference Channel (FRC) H-Set 3 the reference values for R should be scaled (multiplied by 3 and rounding to the nearest integer t-put in kbps, where values of $i+1/2$ are rounded up to $i+1$, i integer)

9.2.1B Single Link Performance - QPSK, Fixed Reference Channel (FRC) H-Set 4/5

9.2.1B.1 Definition and applicability

The receiver single link performance of the High Speed Physical Downlink Shared Channel (HS-DSCH) in different multi-path fading environments are determined by the information bit throughput R.

The requirements and this test apply to Release 5 and later releases for all types of UTRA for the FDD UE that support HSDPA UE capability categories 11 and 12.

9.2.1B.2 Minimum requirements

Requirements for a particular UE belonging to certain HS-DSCH category are determined according to the relevant part of Table 9.2.1.

The requirements are specified in terms of minimum information bit throughput R for the DL reference channels H-set 4/5 specified in Annex C.8.1.4 and C.8.1.5 respectively, with the addition of the relevant parameters in Table 9.2.1B.1 plus the downlink physical channel setup according to table E.5.1.

Using this configuration the throughput shall meet or exceed the minimum requirements specified in Tables 9.2.1B.2 and 9.2.1B.3.

Table 9.2.1B.1: Test Parameters for Testing QPSK FRCs H-Set 4/H-Set 5

Parameter	Unit	Test 1	Test 2	Test 3	Test 4
Phase reference			P-CPICH		
I_{oc}	dBm/3.84 MHz		-60		
Redundancy and constellation version coding sequence			{0,2,5,6}		
Maximum number of HARQ transmission			4		

Note: The HS-SCCH-1 and HS-PDSCH shall be transmitted continuously with constant power. HS-SCCH-1 shall only use the identity of the UE under test for those TTI intended for the UE.

Table 9.2.1B.2: Minimum requirement QPSK, Fixed Reference Channel (FRC) H-Set 4

Test Number	Propagation Conditions	Reference value		
		HS-PDSCH E_c/I_{or} (dB)	T-put R (kbps) * $\hat{I}_{or}/I_{oc} = 0$ dB	T-put R (kbps) * $\hat{I}_{or}/I_{oc} = 10$ dB
1	PA3	-6	72	340
		-3	N/A	439
2	PB3	-6	24	186
		-3	142	299
3	VA30	-6	19	183
		-3	148	306
4	VA120	-6	11	170
		-3	144	284

* Note: The reference value R is for the Fixed Reference Channel (FRC) H-Set 4

Table 9.2.1B.3: Minimum requirement QPSK, Fixed Reference Channel (FRC) H-Set 5

Test Number	Propagation Conditions	Reference value		
		HS-PDSCH E_c/I_{or} (dB)	T-put R (kbps) * $\hat{I}_{or}/I_{oc} = 0$ dB	T-put R (kbps) * $\hat{I}_{or}/I_{oc} = 10$ dB
1	PA3	-6	98	464
		-3	N/A	635
2	PB3	-6	35	272
		-3	207	431
3	VA30	-6	33	285
		-3	213	443
4	VA120	-6	20	272
		-3	210	413

* Note: The reference value R is for the Fixed Reference Channel (FRC) H-Set 5

The reference for this requirement is TS 25.101 [1] clauses 9.2.1.3.

9.2.1B.3 Test purpose

To verify the ability of the receiver to receive a predefined test signal, representing a multi-path fading channel with information bit throughput R not falling below a specified value. The test stresses the multicode reception and channel decoding with incremental redundancy.

9.2.1B.4 Method of test

9.2.1B.4.1 Initial conditions

Test environment: normal; see clauses G.2.1 and G.2.2.

Frequencies to be tested: mid range; see clause G.2.4.

- 1) Connect the SS (node B emulator) and fader and AWGN noise source to the UE antenna connector as shown in figure A.10.
- 2) Set up an HSDPA call with looping back 12.2kbps RMC according to TS 34.108 [3] clause 7.3.6 with levels according to table E.5.0.
- 3) Set the node B emulator behaviour according to table 9.2.4. Set the test parameters for tests 1-4 according to table 9.2.1B.1 and levels according to tables 9.2.1B.4 to 9.2.1B.6 as appropriate. The configuration of the downlink channels is defined in table E.5.1.
- 4) The information bit data shall be pseudo random and not repeated before 10 different information bit payload blocks are processed. (e.g. Fixed reference Channel Definition H-set 5: The information bit payload block is 3202 bits long. Hence the PRBSequence must be at least $3202 * 10$ bits long.) Use a PRBS from ITU-T O.153 Ref [27]

- 5) The SS shall not time the transmission freely. It shall time the transmission strictly according to the reference measurement channels: i.e. Process number is continued exactly after 6 TTIs.
- 6) Setup the fading simulator with fading conditions as described in table D.2.2.1.A

9.2.1B.4.2 Procedure

- 1) Once the HSDPA connection is setup, change levels according to Tables E.5.6 to E.5.8B as specified by table E.5.9 and start transmitting HSDPA Data.
- 2) For all relevant propagation conditions, for all relevant I_{oc} levels, for all relevant E_c/I_{or} , for all relevant \hat{I}_{or}/I_{oc} , for all relevant H-sets in tables 9.2.1B.4 to 9.2.1B.6 count the number of NACK, ACK and statDTX on the UL HS-DPCCH during the test interval and decide pass or fail according to Annex F.6.3 tables F.6.3.5.2.3 and F.6.3.5.2.4.

9.2.1B.5 Test Requirements

Tables 9.2.1B.4 to 9.2.1B.6 define the primary level settings including test tolerance for all relevant throughput tests. The pass / fail decision for throughput is done according to Annex F.6.3.

Tables E.5.6 to E.5.8B define the secondary and subsequently ranked level settings including test tolerance. As those level settings are not uniform for the throughput tests in this clause, Table E.5.9 indicates which levels are applied, when the primary level settings (E_c/I_{or} and I_{or}/I_{oc}) and propagation conditions (PA3, PB3, VA30, VA 120) vary.

Table 9.2.1B.4: Test Parameters for Testing QPSK FRCs H-Set 4/H-Set 5

Parameter	Unit	Test 1	Test 2	Test 3	Test 4
Phase reference		P-CPICH			
I_{oc}	dBm/3.84 MHz	-60 (no test tolerance applied)			

Table 9.2.1B.5: Test requirement QPSK, Fixed Reference Channel (FRC) H-Set 4

Test Number	Propagation Conditions	Reference value		
		HS-PDSCH E_c/I_{or} (dB)	T-put R (kbps) * $\hat{I}_{or}/I_{oc} = 0.6$ dB	T-put R (kbps) * $\hat{I}_{or}/I_{oc} = 10.6$ dB
1	PA3	-5.9	72	340
		-2.9	N/A	439
2	PB3	-5.9	24	186
		-2.9	142	299
3	VA30	-5.9	19	183
		-2.9	148	306
4	VA120	-5.9	11	170
		-2.9	144	284

* Note: The reference value R is for the Fixed Reference Channel (FRC) H-Set 4

Table 9.2.1B.6: Test requirement QPSK, Fixed Reference Channel (FRC) H-Set 5

Test Number	Propagation Conditions	Reference value		
		HS-PDSCH E_c/I_{or} (dB)	T-put R (kbps) * $\hat{I}_{or}/I_{oc} = 0.6$ dB	T-put R (kbps) * $\hat{I}_{or}/I_{oc} = 10.6$ dB
1	PA3	-5.9	98	464
		-2.9	N/A	635
2	PB3	-5.9	35	272
		-2.9	207	431
3	VA30	-5.9	33	285
		-2.9	213	443
4	VA120	-5.9	20	272
		-2.9	210	413

* Notes: The reference value R is for the Fixed Reference Channel (FRC) H-Set 5

9.2.1C Single Link Performance - QPSK/16QAM, Fixed Reference Channel (FRC) H-Set 6/3

9.2.1C.1 Definition and applicability

The receiver single link performance of the High Speed Physical Downlink Shared Channel (HS-DSCH) in different multi-path fading environments are determined by the information bit throughput R.

The requirements and this test apply to Release 6 and later releases for all types of UTRA for the FDD UE that support HSDPA UE capability categories 7 and 8.

9.2.1C.2 Minimum requirements

Requirements for a particular UE belonging to certain HS-DSCH category are determined according to the relevant part of Table 9.2.1.

The requirements are specified in terms of minimum information bit throughput R for the DL reference channels H-set 6/3 specified in Annex C.8.1.6 and C.8.1.3 respectively, with the addition of the relevant parameters in Tables 9.2.1C.1, 9.2.1C.3, 9.2.1C.5 and 9.2.1C.7 plus the downlink physical channel setup according to table E.5.1.

Using this configuration the throughput shall meet or exceed the minimum requirements specified in Tables 9.2.1C.2, 9.2.1C.4, 9.2.1C.6, and 9.2.1C.8.

Table 9.2.1C.1: Test Parameters for Testing QPSK FRCs H-Set 6

Parameter	Unit	Test 1
Phase reference		P-CPICH
I_{oc}	dBm/3.84 MHz	-60
Redundancy and constellation version coding sequence		{0,2,5,6}
Maximum number of HARQ transmission		4
Note:	The HS-SCCH-1 and HS-PDSCH shall be transmitted continuously with constant power. HS-SCCH-1 shall only use the identity of the UE under test for those TTI intended for the UE.	

Table 9.2.1C.2: Minimum requirement QPSK, Fixed Reference Channel (FRC) H-Set 6

Test Number	Propagation Conditions	Reference value	
		HS-PDSCH E_c / I_{or} (dB)	T-put R (kbps) * $\hat{I}_{or} / I_{oc} = 10$ dB
1	PA3	-6	1407
		-3	2090

Table 9.2.1C.3: Test Parameters for Testing 16QAM FRCs H-Set 6

Parameter	Unit	Test 1
Phase reference		P-CPICH
I_{oc}	dBm/3.84 MHz	-60
Redundancy and constellation version coding sequence		{6,2,1,5}
Maximum number of HARQ transmission		4
Note: The HS-SCCH-1 and HS-PDSCH shall be transmitted continuously with constant power. HS-SCCH-1 shall only use the identity of the UE under test for those TTI intended for the UE.		

Table 9.2.1C.4: Minimum requirement 16QAM, Fixed Reference Channel (FRC) H-Set 6

Test Number	Propagation Conditions	Reference value	
		HS-PDSCH E_c / I_{or} (dB)	T-put R (kbps) * $\hat{I}_{or} / I_{oc} = 10$ dB
1	PA3	-6	887
		-3	1664

Table 9.2.1C.5: Test Parameters for Testing QPSK FRCs H-Set 3

Parameter	Unit	Test 2	Test 3	Test 4
Phase reference	dBm/3.84 MHz	P-CPICH		
I_{oc}		-60		
Redundancy and constellation version coding sequence		{0,2,5,6}		
Maximum number of HARQ transmission		4		
Note: The HS-SCCH-1 and HS-PDSCH shall be transmitted continuously with constant power. HS-SCCH-1 shall only use the identity of the UE under test for those TTI intended for the UE.				

Table 9.2.1C.6: Minimum requirement QPSK, Fixed Reference Channel (FRC) H-Set 3

Test Number	Propagation Conditions	Reference value		
		HS-PDSCH E_c / I_{or} (dB)	T-put R (kbps) * $\hat{I}_{or} / I_{oc} = 0$ dB	T-put R (kbps) * $\hat{I}_{or} / I_{oc} = 10$ dB
2	PB3	-6	23	181
		-3	138	287
3	VA30	-6	22	190
		-3	142	295
4	VA120	-6	13	181
		-3	140	275
* Notes: 1) The reference value R is for the Fixed Reference Channel (FRC) H-Set 1, for Fixed Reference Channel (FRC) H-Set 3 the reference values for R should be scaled (multiplied by 3 and rounding to the nearest integer t-put in kbps, where values of $i+1/2$ are rounded up to $i+1$, i integer)				

Table 9.2.1C.7: Test Parameters for Testing 16QAM FRCs H-Set 3

Parameter	Unit	Test 2	Test 3	Test 4
Phase reference	dBm/3.84 MHz	P-CPICH		
I_{oc}		-60		
Redundancy and constellation version coding sequence		{6,2,1,5}		
Maximum number of HARQ transmission		4		
Note: The HS-SCCH-1 and HS-PDSCH shall be transmitted continuously with constant power. HS-SCCH-1 shall only use the identity of the UE under test for those TTI intended for the UE.				

Table 9.2.1C.8: Minimum requirement 16QAM, Fixed Reference Channel (FRC) H-Set 3

Test Number	Propagation Conditions	Reference value	
		HS-PDSCH E_c / I_{or} (dB)	T-put R (kbps) * $\hat{I}_{or} / I_{oc} = 10$ dB
2	PB3	-6	34
		-3	219
3	VA30	-6	47
		-3	214
4	VA120	-6	28
		-3	167
* Notes: 1)The reference value R is for the Fixed Reference Channel (FRC) H-Set 1, for Fixed Reference Channel (FRC) H-Set 3 the reference values for R should be scaled (multiplied by 3 and rounding to the nearest integer t-put in kbps, where values of $i+1/2$ are rounded up to $i+1$, i integer)			

The reference for this requirement is TS 25.101 [1] clauses 9.2.1.1, 9.2.1.2, 9.2.1.4 and 9.2.1.5.

9.2.1C.3 Test purpose

To verify the ability of the receiver to receive a predefined test signal, representing a multi-path fading channel with information bit throughput R not falling below a specified value. The test stresses the multicode reception and channel decoding with incremental redundancy.

9.2.1C.4 Method of test

9.2.1C.4.1 Initial conditions

Test environment: normal; see clauses G.2.1 and G.2.2.

Frequencies to be tested: mid range; see clause G.2.4.

- 1) Connect the SS (node B emulator) and fader and AWGN noise source to the UE antenna connector as shown in figure A.10.
- 2) Set up an HSDPA call with looping back 12.2kbps RMC according to TS 34.108 [3] clause 7.3.6 with levels according to table E.5.0.
- 3) Set the node B emulator behaviour according to table 9.2.4. Set the test parameters for tests 1-4 according to tables 9.2.1C.1, 9.2.1C.3, 9.2.1C.5 or 9.2.1C.7 and levels according to tables 9.2.1C.9 to 9.2.1C.16 respectively. The configuration of the downlink channels is defined in table E.5.1.
- 4) The information bit data shall be pseudo random and not repeated before 10 different information bit payload blocks are processed. (e.g. Fixed reference Channel Definition H-set 3 (16QAM): The information bit payload block is 4664 bits long. Hence the PRBSequence must be at least $4664 * 10$ bits long.) Use a PRBS from ITU-T O.153 Ref [27]
- 5) The SS shall not time the transmission freely. It shall time the transmission strictly according to the reference measurement channels: i.e. Process number is continued exactly after 6 TTIs.

6) Setup the fading simulator with fading conditions as described in table D.2.2.1.A

9.2.1C.4.2 Procedure

- 1) Once the HSDPA connection is setup, change levels according to Tables E.5.6 to E.5.8B as specified by table E.5.9 and start transmitting HSDPA Data.
- 2) For all relevant propagation conditions, for all relevant I_{oc} levels, for all relevant E_c/I_{or} , for all relevant \hat{I}_{or}/I_{oc} , for all relevant H-sets in tables 9.2.1C.9 to 9.2.1C.16 count the number of NACK, ACK and statDTX on the UL HS-DPCCH during the test interval and decide pass or fail according to Annex F.6.3 tables F.6.3.5.2.1, F.6.3.5.2.2, F.6.3.5.2.5 and F.6.3.5.2.6.

9.2.1C.5 Test Requirements

Tables 9.2.1C.9 to 9.2.1C.16 define the primary level settings including test tolerance for all relevant throughput tests. The pass / fail decision for throughput is done according to Annex F.6.3.

Tables E.5.6 to E.5.8B define the secondary and subsequently ranked level settings including test tolerance. As those level settings are not uniform for the throughput tests in this clause, Table E.5.9 indicates which levels are applied, when the primary level settings (E_c/I_{or} and I_{or}/I_{oc}) and propagation conditions (PA3, PB3, VA30, VA 120) vary.

Table 9.2.1C.9: Test Parameters for Testing QPSK FRCs H-Set 6

Parameter	Unit	Test 1
Phase reference		P-CPICH
I_{oc}	dBm/3.84 MHz	-60 (no test tolerance applied)

Table 9.2.1C.10: Test requirement QPSK, Fixed Reference Channel (FRC) H-Set 6

Test Number	Propagation Conditions	Reference value	
		HS-PDSCH E_c / I_{or} (dB)	T-put R (kbps) * $\hat{I}_{or} / I_{oc} = 10.6$ dB
1	PA3	-5.9	1407
		-2.9	2090

Table 9.2.1C.11: Test Parameters for Testing 16QAM FRCs H-Set 6

Parameter	Unit	Test 1
Phase reference		P-CPICH
I_{oc}	dBm/3.84 MHz	-60 (no test tolerance applied)

Table 9.2.1C.12: Test requirement 16QAM, Fixed Reference Channel (FRC) H-Set 6

Test Number	Propagation Conditions	Reference value	
		HS-PDSCH E_c / I_{or} (dB)	T-put R (kbps) * $\hat{I}_{or} / I_{oc} = 10.6$ dB
1	PA3	-5.9	887
		-2.9	1664

Table 9.2.1C.13: Test Parameters for Testing QPSK FRCs H-Set 3

Parameter	Unit	Test 2	Test 3	Test 4
Phase reference		P-CPICH		
I_{oc}	dBm/3.84 MHz	-60 (no test tolerance applied)		

Table 9.2.1C.14: Test requirement QPSK, Fixed Reference Channel (FRC) H-Set 3

Test Number	Propagation Conditions	Reference value		
		HS-PDSCH E_c/I_{or} (dB)	T-put R (kbps) * $\hat{I}_{or}/I_{oc} = 0.6$ dB	T-put R (kbps) * $\hat{I}_{or}/I_{oc} = 10.6$ dB
2	PB3	-5.9	23	181
		-2.9	138	287
3	VA30	-5.9	22	190
		-2.9	142	295
4	VA120	-5.9	13	181
		-2.9	140	275

* Notes: 1) The reference value R is for the Fixed Reference Channel (FRC) H-Set 1, for Fixed Reference Channel (FRC) H-Set 3 the reference values for R should be scaled (multiplied by 3 and rounding to the nearest integer t-put in kbps, where values of $i+1/2$ are rounded up to $i+1$, i integer)

Table 9.2.1C.15: Test Parameters for Testing 16QAM FRCs H-Set 3

Parameter	Unit	Test 2	Test 3	Test 4
Phase reference		P-CPICH		
I_{oc}	dBm/3.84 MHz	-60 (no test tolerance applied)		

Table 9.2.1C.16: Test requirement 16QAM, Fixed Reference Channel (FRC) H-Set 3

Test Number	Propagation Conditions	Reference value	
		HS-PDSCH E_c/I_{or} (dB)	T-put R (kbps) * $\hat{I}_{or}/I_{oc} = 10.6$ dB
2	PB3	-5.9	34
		-2.9	219
3	VA30	-5.9	47
		-2.9	214
4	VA120	-5.9	28
		-2.9	167

* Notes: 1)The reference value R is for the Fixed Reference Channel (FRC) H-Set 1, for Fixed Reference Channel (FRC) H-Set 3 the reference values for R should be scaled (multiplied by 3 and rounding to the nearest integer t-put in kbps, where values of $i+1/2$ are rounded up to $i+1$, i integer)

9.2.1D Single Link Performance - Enhanced Performance Requirements Type 1 - QPSK/16QAM, Fixed Reference Channel (FRC) H-Set 1/2/3

9.2.1D.1 Definition and applicability

The receiver single link performance of the High Speed Physical Downlink Shared Channel (HS-DSCH) in different multi-path fading environments are determined by the information bit throughput R.

The requirements and this test apply for Release 6 and later releases to all types of UTRA for the FDD UE that support: the HSDPA UE capability categories 1 to 6 and the optional enhanced performance requirements type 1.

9.2.1D.2 Minimum requirements

The performance requirements for a particular UE belonging to certain HS-DSCH category and supporting the optional enhanced performance requirements type 1 are determined according to the relevant part of Table 9.2.2.

During the Fixed Reference Channel (FRC) tests the behaviour of the Node-B emulator in response to the ACK/NACK signalling field of the HS-DPCCH is specified in Table 9.2.4.

The requirements are specified in terms of minimum information bit throughput R for the DL reference channels H-set 1/2/3 specified in Annex C.8.1.1, C.8.1.2 and C.8.1.3 respectively, with the addition of the relevant parameters in Tables 9.2.1D.1 and 9.2.1D.3 plus the downlink physical channel setup according to table E.5.1.

Using this configuration the throughput shall meet or exceed the minimum requirements specified in tables 9.2.1D.2 and 9.2.1D.4.

Table 9.2.1D.1: Test Parameters for Testing QPSK FRCs H-Set 1/H-Set 2/H-Set 3

Parameter	Unit	Test 1	Test 2	Test 3	Test 4
Phase reference	dBm/3.84 MHz	P-CPICH			
I_{oc}		-60			
Redundancy and constellation version coding sequence		{0,2,5,6}			
Maximum number of HARQ transmission		4			
Note: The HS-SCCH-1 and HS-PDSCH shall be transmitted continuously with constant power. HS-SCCH-1 shall only use the identity of the UE under test for those TTI intended for the UE.					

Table 9.2.1D.2: Minimum requirement Enhanced requirement type 1 QPSK, Fixed Reference Channel (FRC) H-Set 1/2/3

Test Number	Propagation Conditions	Reference value		
		HS-PDSCH E_c / I_{or} (dB)	T-put R (kbps) * $\hat{I}_{or} / I_{oc} = 0$ dB	T-put R (kbps) * $\hat{I}_{or} / I_{oc} = 10$ dB
1	PA3	-12	N/A	247
		-9	N/A	379
		-6	195	N/A
		-3	329	N/A
2	PB3	-9	N/A	195
		-6	156	316
		-3	263	N/A
3	VA30	-9	N/A	212
		-6	171	329
		-3	273	N/A
4	VA120	-9	N/A	191
		-6	168	293
		-3	263	N/A

* Notes: 1) The reference value R is for the Fixed Reference Channel (FRC) H-Set 1
 2) For Fixed Reference Channel (FRC) H-Set 2 the reference values for R should be scaled (multiplied by 1.5 and rounding to the nearest integer t-put in kbps, where values of $i+1/2$ are rounded up to $i+1$, i integer)
 3) For Fixed Reference Channel (FRC) H-Set 3 the reference values for R should be scaled (multiplied by 3 and rounding to the nearest integer t-put in kbps, where values of $i+1/2$ are rounded up to $i+1$, i integer)

Table 9.2.1D.3: Test Parameters for Testing 16QAM FRCs H-Set 1/H-Set 2/H-Set 3

Parameter	Unit	Test 1	Test 2	Test 3	Test 4
Phase reference	dBm/3.84 MHz	P-CPICH			
I_{oc}		-60			
Redundancy and constellation version coding sequence		{6,2,1,5}			
Maximum number of HARQ transmission		4			
Note: The HS-SCCH-1 and HS-PDSCH shall be transmitted continuously with constant power. HS-SCCH-1 shall only use the identity of the UE under test for those TTI intended for the UE.					

Table 9.2.1D.4: Minimum requirement Enhanced requirement type 1 16QAM, Fixed Reference Channel (FRC) H-Set 1/2/3

Test Number	Propagation Conditions	Reference value	
		HS-PDSCH E_c / I_{or} (dB)	T-put R (kbps)* $\hat{I}_{or} / I_{oc} = 10$ dB
1	PA3	-9	312
		-6	487
2	PB3	-6	275
		-3	408
3	VA30	-6	296
		-3	430
4	VA120	-6	271
		-3	392
* Notes: 1)The reference value R is for the Fixed Reference Channel (FRC) H-Set 1 2) For Fixed Reference Channel (FRC) H-Set 2 the reference values for R should be scaled (multiplied by 1.5 and rounding to the nearest integer t-put in kbps, where values of $i+1/2$ are rounded up to $i+1$, i integer) 3) For Fixed Reference Channel (FRC) H-Set 3 the reference values for R should be scaled (multiplied by 3 and rounding to the nearest integer t-put in kbps, where values of $i+1/2$ are rounded up to $i+1$, i integer)			

The reference for this requirement is TS 25.101 [1] clauses 9.2.1.1 and 9.2.1.2.

9.2.1D.3 Test purpose

To verify the ability of the receiver to receive a predefined test signal, representing a multi-path fading channel with information bit throughput R not falling below a specified value. The test stresses the multicode reception and channel decoding with incremental redundancy.

9.2.1D.4 Method of test

9.2.1D.4.1 Initial conditions

Test environment: normal; see clauses G.2.1 and G.2.2.

Frequencies to be tested: mid range; see clause G.2.4.

- 1) Connect the SS (node B emulator) and faders and AWGN noise sources to the UE antenna connectors as shown in figure A.21 for UEs that support receive diversity or figure A.10 for UEs that do not support receive diversity.
- 2) Set up an HSDPA call with looping back 12.2kbps RMC according to TS 34.108 [3] clause 7.3.6 with levels according to table E.5.0.
- 3) Set the node B emulator behaviour according to table 9.2.4. Set the test parameters for tests 1-4 according to table 9.2.1D.1 or 9.2.1D.3 and the levels according to tables 9.2.1D.5 to 9.2.1D.8 as appropriate. The configuration of the downlink channels is defined in table E.5.1.

- 4) The information bit data shall be pseudo random and not repeated before 10 different information bit payload blocks are processed. (e.g. Fixed reference Channel Definition H-set 1 (16 QAM): The information bit payload block is 4664 bits long. Hence the PRBSequence must be at least 4664 * 10 bits long.) Use a PRBS from ITU-T O.153 Ref [27]
- 5) The SS shall not time the transmission freely. It shall time the transmission strictly according to the reference measurement channels: i.e. Process number i is continued exactly after 6 TTIs.
- 6) Setup the fading simulators with fading conditions as described in table D.2.2.1.A and for UEs that support receive diversity as also described in clause D.2.5.

9.2.1D.4.2 Procedure

- 1) Once the HSDPA connection is setup, change levels according to Tables E.5.6 to E.5.8B as specified by table E.5.9 and start transmitting HSDPA Data.
- 2) For all relevant propagation conditions, for all relevant Ioc levels, for all relevant Ec/Ior, for all relevant \hat{I}_{or}/I_{oc} , for all relevant H-sets in tables 9.2.1D.5 to 9.2.1D.8 count the number of NACK, ACK and statDTX on the UL HS-DPCCH during the test interval and decide pass or fail according to Annex F.6.3 tables F.6.3.5.2.1A and F.6.3.5.2.2A.

9.2.1D.5 Test Requirements

Tables 9.2.1D.5 to 9.2.1D.8 define the primary level settings including test tolerance for all relevant throughput tests. The pass / fail decision for throughput is done according to Annex F.6.3.

Tables E.5.6 to E.5.8B define the secondary and subsequently ranked level settings including test tolerance. As those level settings are not uniform for the throughput tests in this clause, Table E.5.9 indicates which levels are applied, when the primary level settings (Ec/Ior and Ior/Ioc) and propagation conditions (PA3,PB3, VA30, VA 120) vary.

Table 9.2.1D.5: Test Parameters for Testing QPSK FRCs H-Set 1/H-Set 2/H-Set 3

Parameter	Unit	Test 1	Test 2	Test 3	Test 4
Phase reference		P-CPICH			
I_{oc}	dBm/3.84 MHz	-60 (no test tolerance applied)			

Table 9.2.1D.6: Test requirement enhanced requirement type 1 QPSK, Fixed Reference Channel (FRC) H-Set 1/2/3

Test Number	Propagation Conditions	Reference value		
		HS-PDSCH E_c / I_{or} (dB)	T-put R (kbps) * $\hat{I}_{or} / I_{oc} = 0.6$ dB	T-put R (kbps) * $\hat{I}_{or} / I_{oc} = 10.6$ dB
1	PA3	-11.9	N/A	247
		-8.9	N/A	379
		-5.9	195	N/A
		-2.9	329	N/A
2	PB3	-8.9	N/A	195
		-5.9	156	316
		-2.9	263	N/A
3	VA30	-8.9	N/A	212
		-5.9	171	329
		-2.9	273	N/A
4	VA120	-8.9	N/A	191
		-5.9	168	293
		-2.9	263	N/A

* Notes: 1) The reference value R is for the Fixed Reference Channel (FRC) H-Set 1
 2) For Fixed Reference Channel (FRC) H-Set 2 the reference values for R should be scaled (multiplied by 1.5 and rounding to the nearest integer t-put in kbps, where values of $i+1/2$ are rounded up to $i+1$, i integer)
 3) For Fixed Reference Channel (FRC) H-Set 3 the reference values for R should be scaled (multiplied by 3 and rounding to the nearest integer t-put in kbps, where values of $i+1/2$ are rounded up to $i+1$, i integer)

Table 9.2.1D.7: Test Parameters for Testing 16QAM FRCs H-Set 1/H-Set 2/H-Set 3

Parameter	Unit	Test 1	Test 2	Test 3	Test 4
Phase reference		P-CPICH			
I_{oc}	dBm/3.84 MHz	-60 (no test tolerance applied)			

Table 9.2.1D.8: Test requirement enhanced requirement type 1 16QAM, Fixed Reference Channel (FRC) H-Set 1/2/3

Test Number	Propagation Conditions	Reference value	
		HS-PDSCH E_c / I_{or} (dB)	T-put R (kbps) * $\hat{I}_{or} / I_{oc} = 10.6$ dB
1	PA3	-8.9	312
		-5.9	487
2	PB3	-5.9	275
		-2.9	408
3	VA30	-5.9	296
		-2.9	430
4	VA120	-5.9	271
		-2.9	392

* Notes: 1) The reference value R is for the Fixed Reference Channel (FRC) H-Set 1
2) For Fixed Reference Channel (FRC) H-Set 2 the reference values for R should be scaled (multiplied by 1.5 and rounding to the nearest integer t-put in kbps, where values of $i+1/2$ are rounded up to $i+1$, i integer)
3) For Fixed Reference Channel (FRC) H-Set 3 the reference values for R should be scaled (multiplied by 3 and rounding to the nearest integer t-put in kbps, where values of $i+1/2$ are rounded up to $i+1$, i integer)

9.2.1E Single Link Performance - Enhanced Performance Requirements Type 1- QPSK/16QAM, Fixed Reference Channel (FRC) H-Set 6/3

9.2.1E.1 Definition and applicability

The receiver single link performance of the High Speed Physical Downlink Shared Channel (HS-DSCH) in different multi-path fading environments are determined by the information bit throughput R.

The requirements and this test apply for Release 6 and later releases to all types of UTRA for the FDD UE that support: HSDPA UE capability categories 7 and 8; and the optional enhanced performance requirements type 1.

9.2.1E.2 Minimum requirements

The performance requirements for a particular UE belonging to certain HS-DSCH category and supporting the optional enhanced performance requirements type 1 are determined according to the relevant part of Table 9.2.2.

During the Fixed Reference Channel (FRC) tests the behaviour of the Node-B emulator in response to the ACK/NACK signalling field of the HS-DPCCH is specified in Table 9.2.4.

The requirements are specified in terms of minimum information bit throughput R for the DL reference channels H-set 6/3 specified in Annex C.8.1.6 and C.8.1.3 respectively, with the addition of the relevant parameters in Tables 9.2.1E.1, 9.2.1E.3, 9.2.1E.5 and 9.2.1E.7 plus the downlink physical channel setup according to table E.5.1.

Using this configuration the throughput shall meet or exceed the minimum requirements specified in tables 9.2.1E.2, 9.2.1E.4, 9.2.1E.6 and 9.2.1E.8.

Table 9.2.1E.1: Test Parameters for Testing QPSK FRCs H-Set 6

Parameter	Unit	Test 1
Phase reference		P-CPICH
I_{oc}	dBm/3.84 MHz	-60
Redundancy and constellation version coding sequence		{0,2,5,6}
Maximum number of HARQ transmission		4
Note:	The HS-SCCH-1 and HS-PDSCH shall be transmitted continuously with constant power. HS-SCCH-1 shall only use the identity of the UE under test for those TTI intended for the UE.	

Table 9.2.1E.2: Minimum requirement Enhanced requirements type 1 QPSK, Fixed Reference Channel (FRC) H-Set 6

Test Number	Propagation Conditions	Reference value	
		HS-PDSCH E_c / I_{or} (dB)	T-put R (kbps) * $\hat{I}_{or} / I_{oc} = 10$ dB
1	PA3	-12	672
		-9	1305

Table 9.2.1E.3: Test Parameters for Testing 16QAM FRCs H-Set 6

Parameter	Unit	Test 1
Phase reference		P-CPICH
I_{oc}	dBm/3.84 MHz	-60
Redundancy and constellation version coding sequence		{6,2,1,5}
Maximum number of HARQ transmission		4
Note:	The HS-SCCH-1 and HS-PDSCH shall be transmitted continuously with constant power. HS-SCCH-1 shall only use the identity of the UE under test for those TTI intended for the UE.	

Table 9.2.1E.4: Minimum requirement Enhanced requirements type 1 16QAM, Fixed Reference Channel (FRC) H-Set 6

Test Number	Propagation Conditions	Reference value	
		HS-PDSCH E_c / I_{or} (dB)	T-put R (kbps) * $\hat{I}_{or} / I_{oc} = 10$ dB
1	PA3	-9	912
		-6	1730

Table 9.2.1E.5: Test Parameters for Testing QPSK FRCs H-Set 3

Parameter	Unit	Test 2	Test 3	Test 4
Phase reference	dBm/3.84 MHz	P-CPICH		
I_{oc}		-60		
Redundancy and constellation version coding sequence		{0,2,5,6}		
Maximum number of HARQ transmission		4		
Note:	The HS-SCCH-1 and HS-PDSCH shall be transmitted continuously with constant power. HS-SCCH-1 shall only use the identity of the UE under test for those TTI intended for the UE.			

Table 9.2.1E.6: Minimum requirement Enhanced requirement type 1 QPSK, Fixed Reference Channel (FRC) H-Set 3

Test Number	Propagation Conditions	Reference value		
		HS-PDSCH E_c/I_{or} (dB)	T-put R (kbps) * $\hat{I}_{or}/I_{oc} = 0$ dB	T-put R (kbps) * $\hat{I}_{or}/I_{oc} = 10$ dB
2	PB3	-9	N/A	195
		-6	156	316
		-3	263	N/A
3	VA30	-9	N/A	212
		-6	171	329
		-3	273	N/A
4	VA120	-9	N/A	191
		-6	168	293
		-3	263	N/A

* Notes: 1) The reference value R is for the Fixed Reference Channel (FRC) H-Set 1, for Fixed Reference Channel (FRC) H-Set 3 the reference values for R should be scaled (multiplied by 3 and rounding to the nearest integer t-put in kbps, where values of $i+1/2$ are rounded up to $i+1$, i integer)

Table 9.2.1E.7: Test Parameters for Testing 16QAM FRCs H-Set 3

Parameter	Unit	Test 2	Test 3	Test 4
Phase reference	dBm/3.84 MHz	P-CPICH		
I_{oc}		-60		
Redundancy and constellation version coding sequence		{6,2,1,5}		
Maximum number of HARQ transmission		4		

Note: The HS-SCCH-1 and HS-PDSCH shall be transmitted continuously with constant power. HS-SCCH-1 shall only use the identity of the UE under test for those TTI intended for the UE.

Table 9.2.1E.8: Minimum requirement Enhanced requirement type 1 16QAM, Fixed Reference Channel (FRC) H-Set 3

Test Number	Propagation Conditions	Reference value	
		HS-PDSCH E_c/I_{or} (dB)	T-put R (kbps) * $\hat{I}_{or}/I_{oc} = 10$ dB
2	PB3	-6	275
		-3	408
3	VA30	-6	296
		-3	430
4	VA120	-6	271
		-3	392

* Notes: 1) The reference value R is for the Fixed Reference Channel (FRC) H-Set 1, for Fixed Reference Channel (FRC) H-Set 3 the reference values for R should be scaled (multiplied by 3 and rounding to the nearest integer t-put in kbps, where values of $i+1/2$ are rounded up to $i+1$, i integer)

The reference for this requirement is TS 25.101 [1] clauses 9.2.1.1, 9.2.1.2, 9.2.1.4, and 9.2.1.5.

9.2.1E.3 Test purpose

To verify the ability of the receiver to receive a predefined test signal, representing a multi-path fading channel with information bit throughput R not falling below a specified value. The test stresses the multicode reception and channel decoding with incremental redundancy.

9.2.1E.4 Method of test

9.2.1E.4.1 Initial conditions

Test environment: normal; see clauses G.2.1 and G.2.2.

Frequencies to be tested: mid range; see clause G.2.4.

- 1) The SS (node B emulator) and faders and AWGN noise sources to the UE antenna connectors as shown in figure A.21 for UEs that support receive diversity or figure A.10 for UEs that do not support receive diversity.
- 2) Set up an HSDPA call with looping back 12.2kbps RMC according to TS 34.108 [3] clause 7.3.6 with levels according to table E.5.0.
- 3) Set the node B emulator behaviour according to table 9.2.4. Set the test parameters for tests 1-4 according to table 9.2.1E.1, 9.2.1E.3 or 9.2.1E.5 and levels according to tables 9.2.1E.9 to 9.2.1E.16 as appropriate. The configuration of the downlink channels is defined in table E.5.1.
- 4) The information bit data shall be pseudo random and not repeated before 10 different information bit payload blocks are processed. (e.g. Fixed reference Channel Definition H-set 3 (16 QAM): The information bit payload block is 4664 bits long. Hence the PRBSequence must be at least $4664 * 10$ bits long.) Use a PRBS from ITU-T O.153 Ref [27]
- 5) The SS shall not time the transmission freely. It shall time the transmission strictly according to the reference measurement channels: i.e. Process number i is continued exactly after 6 TTIs.
- 6) Setup the fading simulators with fading conditions as described in table D.2.2.1.A and for UEs that support receive diversity as also described in clause D.2.5.

9.2.1E.4.2 Procedure

- 1) Once the HSDPA connection is setup, change levels according to Tables E.5.6 to E.5.8B as specified by table E.5.9 and start transmitting HSDPA Data.
- 2) For all relevant propagation conditions, for all relevant I_{oc} levels, for all relevant E_c/I_{or} , for all relevant \hat{I}_{or}/I_{oc} , for all relevant H-sets in tables 9.2.1E.9 to 9.2.1E.16 count the number of NACK, ACK and statDTX on the UL HS-DPCCH during the test interval and decide pass or fail according to Annex F.6.3 tables F.6.3.5.2.1A, F.6.3.5.2.2A, F.6.3.5.2.5A and F.6.3.5.2.6A.

9.2.1E.5 Test Requirements

Tables 9.2.1E.9 to 9.2.1E.16 define the primary level settings including test tolerance for all relevant throughput tests. The pass / fail decision for throughput is done according to Annex F.6.3.

Tables E.5.6 to E.5.8B define the secondary and subsequently ranked level settings including test tolerance. As those level settings are not uniform for the throughput tests in this clause, Table E.5.9 indicates which levels are applied, when the primary level settings (E_c/I_{or} and I_{or}/I_{oc}) and propagation conditions (PA3, PB3, VA30, VA 120) vary.

Table 9.2.1E.9: Test Parameters for Testing QPSK FRCs H-Set 6

Parameter	Unit	Test 1
Phase reference		P-CPICH
I_{oc}	dBm/3.84 MHz	-60 (no test tolerance applied)

Table 9.2.1E.10: Test requirement enhanced requirements type 1 QPSK, Fixed Reference Channel (FRC) H-Set 6

Test Number	Propagation Conditions	Reference value	
		HS-PDSCH E_c/I_{or} (dB)	T-put R (kbps) * $\hat{I}_{or}/I_{oc} = 10.6$ dB
1	PA3	-11.9	672
		-8.9	1305

Table 9.2.1E.11: Test Parameters for Testing 16QAM FRCs H-Set 6

Parameter	Unit	Test 1
Phase reference		P-CPICH
I_{oc}	dBm/3.84 MHz	-60 (no test tolerance applied)

Table 9.2.1E.12: Test requirement enhanced requirements type 1 16QAM, Fixed Reference Channel (FRC) H-Set 6

Test Number	Propagation Conditions	Reference value	
		HS-PDSCH E_c / I_{or} (dB)	T-put R (kbps) * $\hat{I}_{or} / I_{oc} = 10.6$ dB
1	PA3	-8.9	912
		-5.9	1730

Table 9.2.1E.13: Test Parameters for Testing QPSK FRCs H-Set 3

Parameter	Unit	Test 2	Test 3	Test 4
Phase reference		P-CPICH		
I_{oc}	dBm/3.84 MHz	-60 (no test tolerance applied)		

Table 9.2.1E.14: Test requirement enhanced requirement type 1 QPSK, Fixed Reference Channel (FRC) H-Set 3

Test Number	Propagation Conditions	Reference value		
		HS-PDSCH E_c / I_{or} (dB)	T-put R (kbps) * $\hat{I}_{or} / I_{oc} = 0.6$ dB	T-put R (kbps) * $\hat{I}_{or} / I_{oc} = 10.6$ dB
2	PB3	-8.9	N/A	195
		-5.9	156	316
		-2.9	263	N/A
3	VA30	-8.9	N/A	212
		-5.9	171	329
		-2.9	273	N/A
4	VA120	-8.9	N/A	191
		-5.9	168	293
		-2.9	263	N/A

* Notes: 1) The reference value R is for the Fixed Reference Channel (FRC) H-Set 1, for Fixed Reference Channel (FRC) H-Set 3 the reference values for R should be scaled (multiplied by 3 and rounding to the nearest integer t-put in kbps, where values of i+1/2 are rounded up to i+1, i integer)

Table 9.2.1E.15: Test Parameters for Testing 16QAM FRCs H-Set 3

Parameter	Unit	Test 2	Test 3	Test 4
Phase reference		P-CPICH		
I_{oc}	dBm/3.84 MHz	-60 (no test tolerance applied)		

Table 9.2.1E.16: Test requirement enhanced requirement type 1 16QAM, Fixed Reference Channel (FRC) H-Set 3

Test Number	Propagation Conditions	Reference value	
		HS-PDSCH E_c / I_{or} (dB)	T-put R (kbps) * $\hat{I}_{or} / I_{oc} = 10.6$ dB
2	PB3	-5.9	275
		-2.9	408
3	VA30	-5.9	296
		-2.9	430
4	VA120	-5.9	271
		-2.9	392

* Notes: 1)The reference value R is for the Fixed Reference Channel (FRC) H-Set 1, for Fixed Reference Channel (FRC) H-Set 3 the reference values for R should be scaled (multiplied by 3 and rounding to the nearest integer t-put in kbps, where values of $i+1/2$ are rounded up to $i+1$, i integer)

9.2.1F Single Link Performance - Enhanced Performance Requirements Type 2 - QPSK/16QAM, Fixed Reference Channel (FRC) H-Set 6/3

9.2.1F.1 Definition and applicability

The receiver single link performance of the High Speed Physical Downlink Shared Channel (HS-DSCH) in different multi-path fading environments are determined by the information bit throughput R.

The requirements and this test apply for Release 6 and later releases to all types of UTRA for the FDD UE that support: HSDPA UE capability categories 7 and 8 and the optional enhanced performance requirements type 2.

9.2.1F.2 Minimum requirements

The performance requirements for a particular UE belonging to HS-DSCH categories 7 and 8 and supporting the optional enhanced performance requirements type 2 are determined according to the relevant part of Table 9.2.3.

During the Fixed Reference Channel (FRC) tests the behaviour of the Node-B emulator in response to the ACK/NACK signalling field of the HS-DPCCH is specified in Table 9.2.4.

The requirements are specified in terms of minimum information bit throughput R for the DL reference channels H-set 6/3 specified in Annex C.8.1.6 and C.8.1.3 respectively, with the addition of the relevant parameters in Tables 9.2.1F.1, 9.2.1F.3 and 9.2.1F.5 plus the downlink physical channel setup according to table E.5.1.

Using this configuration the throughput shall meet or exceed the minimum requirements specified in tables 9.2.1F.2, 9.2.1F.4 and 9.2.1F.6.

Table 9.2.1F.1: Test Parameters for Testing QPSK FRCs H-Set 6

Parameter	Unit	Test 1	Test 2	Test 3	Test 4
Phase reference		P-CPICH			
I_{oc}	dBm/3.84 MHz	-60			
Redundancy and constellation version coding sequence		{0,2,5,6}			
Maximum number of HARQ transmission		4			
Note:	The HS-SCCH-1 and HS-PDSCH shall be transmitted continuously with constant power. HS-SCCH-1 shall only use the identity of the UE under test for those TTI intended for the UE.				

Table 9.2.1F.2: Minimum requirement Enhanced requirement type 2 QPSK, Fixed Reference Channel (FRC) H-Set 6

Test Number	Propagation Conditions	Reference value	
		HS-PDSCH E_c / I_{or} (dB)	T-put R (kbps) * $\hat{I}_{or} / I_{oc} = 10$ dB
1	PA3	-6	1494
		-3	2153
2	PB3	-6	1038
		-3	1744
3	VA30	-6	1142
		-3	1782
4	VA120	-6	909
		-3	1467

Table 9.2.1F.3: Test Parameters for Testing 16QAM FRCs H-Set 6

Parameter	Unit	Test 1	Test 2	Test 3	Test 4
Phase reference		P-CPICH			
I_{oc}	dBm/3.84 MHz	-60			
Redundancy and constellation version coding sequence		{6,2,1,5}			
Maximum number of HARQ transmission		4			
Note:	The HS-SCCH-1 and HS-PDSCH shall be transmitted continuously with constant power. HS-SCCH-1 shall only use the identity of the UE under test for those TTI intended for the UE.				

Table 9.2.1F.4: Minimum requirement Enhanced requirement type 2 16QAM, Fixed Reference Channel (FRC) H-Set 6

Test Number	Propagation Conditions	Reference value	
		HS-PDSCH E_c/I_{or} (dB)	T-put R (kbps) * $\hat{I}_{or}/I_{oc} = 10$ dB
1	PA3	-6	991
		-3	1808
2	PB3	-6	465
		-3	1370
3	VA30	-6	587
		-3	1488
4	VA120	-6	386
		-3	1291

Table 9.2.1F.5: Test Parameters for Testing QPSK FRCs H-Set 3

Parameter	Unit	Test 1	Test 2	Test 3	Test 4
Phase reference	dBm/3.84 MHz	P-CPICH			
I_{oc}		-60			
Redundancy and constellation version coding sequence		{0,2,5,6}			
Maximum number of HARQ transmission		4			
Note:	The HS-SCCH-1 and HS-PDSCH shall be transmitted continuously with constant power. HS-SCCH-1 shall only use the identity of the UE under test for those TTI intended for the UE.				

Table 9.2.1F.6: Minimum requirement Enhanced requirement type 2 QPSK, Fixed Reference Channel (FRC) H-Set 3

Test Number	Propagation Conditions	Reference value		
		HS-PDSCH E_c/I_{or} (dB)	T-put R (kbps) * $\hat{I}_{or}/I_{oc} = 0$ dB	T-put R (kbps) * $\hat{I}_{or}/I_{oc} = 10$ dB
1	PA3	-6	65	N/A
		-3	N/A	N/A
2	PB3	-6	23	N/A
		-3	138	N/A
3	VA30	-6	22	N/A
		-3	142	N/A
4	VA120	-6	13	N/A
		-3	140	N/A
* Notes:	1) The reference value R is for the Fixed Reference Channel (FRC) H-Set 1, for Fixed Reference Channel (FRC) H-Set 3 the reference values for R should be scaled (multiplied by 3 and rounding to the nearest integer t-put in kbps, where values of $i+1/2$ are rounded up to $i+1$, i integer) 2) For UE supporting enhanced performance requirement type 2 and condition $\hat{I}_{or}/I_{oc} = 10$ dB this is tested using the Fixed Reference Channel (FRC) H-Set 6.			

The reference for this requirement is TS 25.101 [1] clauses 9.2.1.1, 9.2.1.2, 9.2.1.4, and 9.2.1.5.

9.2.1F.3 Test purpose

To verify the ability of the receiver to receive a predefined test signal, representing a multi-path fading channel with information bit throughput R not falling below a specified value. The test stresses the multicode reception and channel decoding with incremental redundancy.

9.2.1F.4 Method of test

9.2.1F.4.1 Initial conditions

Test environment: normal; see clauses G.2.1 and G.2.2.

Frequencies to be tested: mid range; see clause G.2.4.

- 1) Connect the SS (node B emulator) and fader and AWGN noise source to the UE antenna connector as shown in figure A.10.
- 2) Set up an HSDPA call with looping back 12.2kbps RMC according to TS 34.108 [3] clause 7.3.6 with levels according to table E.5.0.
- 3) Set the node B emulator behaviour according to table 9.2.4. Set the test parameters for tests 1-4 according to table 9.2.1F.1, 9.2.1F.3 or 9.2.1F.5 and levels according to tables 9.2.1F.7 to 9.2.1F.12 as appropriate. The configuration of the downlink channels is defined in table E.5.1.
- 4) The information bit data shall be pseudo random and not repeated before 10 different information bit payload blocks are processed. (e.g. Fixed reference Channel Definition H-set 6 (16 QAM): The information bit payload block is 9377 bits long. Hence the PRBSequence must be at least $9377 * 10$ bits long.) Use a PRBS from ITU-T O.153 Ref [27]
- 5) The SS shall not time the transmission freely. It shall time the transmission strictly according to the reference measurement channels: i.e. Process number is continued exactly after 6 TTIs.
- 6) Setup the fading simulator with fading conditions as described in table D.2.2.1.A.

9.2.1F.4.2 Procedure

- 1) Once the HSDPA connection is setup, change levels according to Tables E.5.6 to E.5.8B as specified by table E.5.9 and start transmitting HSDPA Data.
- 2) For all relevant propagation conditions, for all relevant I_{oc} levels, for all relevant E_c/I_{or} , for all relevant I_{or}/I_{oc} , for all relevant H-sets in tables 9.2.1F.7 to 9.2.1F.12 count the number of NACK, ACK and statDTX on the UL HS-DPCCH during the test interval and decide pass or fail according to Annex F.6.3 tables F.6.3.5.2.1, F.6.3.5.2.5B and F.6.3.5.2.6B.

9.2.1F.5 Test Requirements

Tables 9.2.1F.7 to 9.2.1F.12 define the primary level settings including test tolerance for all relevant throughput tests. The pass / fail decision for throughput is done according to Annex F.6.3.

Tables E.5.6 to E.5.8B define the secondary and subsequently ranked level settings including test tolerance. As those level settings are not uniform for the throughput tests in this clause, Table E.5.9 indicates which levels are applied, when the primary level settings (E_c/I_{or} and I_{or}/I_{oc}) and propagation conditions (PA3,PB3, VA30, VA 120) vary.

Table 9.2.1F.7: Test Parameters for Testing QPSK FRCs H-Set 6

Parameter	Unit	Test 1	Test 2	Test 3	Test 4
Phase reference		P-CPICH			
I_{oc}	dBm/3.84 MHz	-60 (no test tolerance applied)			

Table 9.2.1F.8: Test requirement enhanced requirement type 2 QPSK, Fixed Reference Channel (FRC) H-Set 6

Test Number	Propagation Conditions	Reference value	
		HS-PDSCH E_c / I_{or} (dB)	T-put R (kbps) * $\hat{I}_{or} / I_{oc} = 10.6$ dB
1	PA3	-5.9	1494
		-2.9	2153
2	PB3	-5.9	1038
		-2.9	1744
3	VA30	-5.9	1142
		-2.9	1782
4	VA120	-5.9	909
		-2.9	1467

Table 9.2.1F.9: Test Parameters for Testing 16QAM FRCs H-Set 6

Parameter	Unit	Test 1	Test 2	Test 3	Test 4
Phase reference		P-CPICH			
I_{oc}	dBm/3.84 MHz	-60 (no test tolerance applied)			

Table 9.2.1F.10: Test requirement enhanced requirement type 2 16QAM, Fixed Reference Channel (FRC) H-Set 6

Test Number	Propagation Conditions	Reference value	
		HS-PDSCH E_c / I_{or} (dB)	T-put R (kbps) * $\hat{I}_{or} / I_{oc} = 10.6$ dB
1	PA3	-5.9	991
		-2.9	1808
2	PB3	-5.9	465
		-2.9	1370
3	VA30	-5.9	587
		-2.9	1488
4	VA120	-5.9	386
		-2.9	1291

Table 9.2.1F.11: Test Parameters for Testing QPSK FRCs H-Set 3

Parameter	Unit	Test 1	Test 2	Test 3	Test 4
Phase reference		P-CPICH			
I_{oc}	dBm/3.84 MHz	-60 (no test tolerance applied)			

Table 9.2.1F.12: Test requirement QPSK, Fixed Reference Channel (FRC) H-Set 3

Test Number	Propagation Conditions	Reference value		
		HS-PDSCH E_c / I_{or} (dB)	T-put R (kbps) * $\hat{I}_{or} / I_{oc} = 0.6$ dB	T-put R (kbps) * $\hat{I}_{or} / I_{oc} = 10.6$ dB
1	PA3	-5.9	65	N/A
		-2.9	N/A	N/A
2	PB3	-5.9	23	N/A
		-2.9	138	N/A
3	VA30	-5.9	22	N/A
		-2.9	142	N/A
4	VA120	-5.9	13	N/A
		-2.9	140	N/A

* Notes: 1) The reference value R is for the Fixed Reference Channel (FRC) H-Set 1, for Fixed Reference Channel (FRC) H-Set 3 the reference values for R should be scaled (multiplied by 3 and rounding to the nearest integer t-put in kbps, where values of $i+1/2$ are rounded up to $i+1$, i integer)
2) For UE supporting enhanced performance requirement type 2 and condition $\hat{I}_{or} / I_{oc} = 10$ dB this is tested using the Fixed Reference Channel (FRC) H-Set 6.

9.2.1G Single Link Performance - Enhanced Performance Requirements Type 3 - QPSK/16QAM, Fixed Reference Channel (FRC) H-Set 6/3

9.2.1G.1 Definition and applicability

The receiver single link performance of the High Speed Physical Downlink Shared Channel (HS-DSCH) in different multi-path fading environments are determined by the information bit throughput R.

The requirements and this test apply for Release 7 and later releases to all types of UTRA for the FDD UE that support: HSDPA UE capability categories 7 and 8 and the optional enhanced performance requirements type 3.

9.2.1G.2 Minimum requirements

The performance requirements for a particular UE belonging to HS-DSCH categories 7 and 8 and supporting the optional enhanced performance requirements type 3 are determined according to the relevant part of Table 9.2.3A.

During the Fixed Reference Channel (FRC) tests the behaviour of the Node-B emulator in response to the ACK/NACK signalling field of the HS-DPCCH is specified in Table 9.2.4.

The requirements are specified in terms of minimum information bit throughput R for the DL reference channels H-set 6/3 specified in Annex C.8.1.6 and C.8.1.3 respectively, with the addition of the relevant parameters in Tables 9.2.1G.1 and 9.2.1G.4 plus the downlink physical channel setup according to table E.5.1.

Using this configuration the throughput shall meet or exceed the minimum requirements specified in tables 9.2.1G.2, 9.2.1G.3, 9.2.1G.5 and 9.2.1G.6.

Table 9.2.1G.1: Test Parameters for Testing QPSK FRCs H-Set 6

Parameter	Unit	Test 1	Test 2	Test 3	Test 4	Test 5
Phase reference		P-CPICH				
I_{oc}	dBm/3.84 MHz	-60				
Redundancy and constellation version coding sequence		{0,2,5,6}				
Maximum number of HARQ transmission		4				
Note:	The HS-SCCH-1 and HS-PDSCH shall be transmitted continuously with constant power. HS-SCCH-1 shall only use the identity of the UE under test for those TTI intended for the UE.					

Table 9.2.1G.2: Minimum requirement Enhanced requirement type 3 QPSK at $\hat{I}_{or}/I_{oc} = 10$ dB, Fixed Reference Channel (FRC) H-Set 6

Test Number	Propagation Conditions	Reference value	
		HS-PDSCH E_c/I_{or} (dB)	T-put R (kbps) * $\hat{I}_{or}/I_{oc} = 10$ dB
1	PA3	-9	1554
		-6	2495
2	PB3	-9	1190
		-6	2098
3	VA30	-9	1229
		-6	2013
4	VA120	-9	1060
		-6	1674

Table 9.2.1G.3: Minimum requirement Enhanced requirement type 3 QPSK at $\hat{I}_{or}/I_{oc} = 5$ dB, Fixed Reference Channel (FRC) H-Set 6

Test Number	Propagation Conditions	Reference value	
		HS-PDSCH E_c/I_{or} (dB)	T-put R (kbps) * $\hat{I}_{or}/I_{oc} = 5$ dB
5	PB3	-6	1248
		-3	2044

Table 9.2.1G.4: Test Parameters for Testing 16QAM FRCs H-Set 6

Parameter	Unit	Test 1	Test 2	Test 3	Test 4	Test 5
Phase reference		P-CPICH				
I_{oc}	dBm/3.84 MHz	-60				
Redundancy and constellation version coding sequence		{6,2,1,5}				
Maximum number of HARQ transmission		4				
Note:	The HS-SCCH-1 and HS-PDSCH shall be transmitted continuously with constant power. HS-SCCH-1 shall only use the identity of the UE under test for those TTI intended for the UE.					

Table 9.2.1G.5: Minimum requirement Enhanced requirement type 3 16QAM at $\hat{I}_{or}/I_{oc} = 10$ dB, Fixed Reference Channel (FRC) H-Set 6

Test Number	Propagation Conditions	Reference value	
		HS-PDSCH E_c/I_{or} (dB)	T-put R (kbps) * $\hat{I}_{or}/I_{oc} = 10$ dB
1	PA3	-6	1979
		-3	3032
2	PB3	-6	1619
		-3	2464
3	VA30	-6	1710
		-3	2490
4	VA120	-6	1437
		-3	2148

Table 9.2.1G.6: Minimum requirement Enhanced requirement type 3 16QAM at $\hat{I}_{or}/I_{oc} = 5$ dB, Fixed Reference Channel (FRC) H-Set 6

Test Number	Propagation Conditions	Reference value	
		HS-PDSCH E_c/I_{or} (dB)	T-put R (kbps) * $\hat{I}_{or}/I_{oc} = 5$ dB
5	PB3	-6	779
		-3	1688

The reference for this requirement is TS 25.101 [1] clauses 9.2.1.1, 9.2.1.2, 9.2.1.4, and 9.2.1.5.

9.2.1G.3 Test purpose

To verify the ability of the receiver to receive a predefined test signal, representing a multi-path fading channel with information bit throughput R not falling below a specified value. The test stresses the multicode reception and channel decoding with incremental redundancy.

9.2.1G.4 Method of test

9.2.1G.4.1 Initial conditions

Test environment: normal; see clauses G.2.1 and G.2.2.

Frequencies to be tested: mid range; see clause G.2.4.

- 1) Connect the SS (node B emulator) and fader and AWGN noise source to the UE antenna connector as shown in figure A.21 for UEs that support receive diversity or figure A.10 for UEs that do not support receive diversity.
- 2) Set up an HSDPA call with looping back 12.2kbps RMC according to TS 34.108 [3] clause 7.3.6 with levels according to table E.5.0.
- 3) Set the node B emulator behaviour according to table 9.2.4. Set the test parameters for tests 1-4 according to table 9.2.1G.1 or 9.2.1G.4 and levels according to tables 9.2.1G.7 to 9.2.1G.12 as appropriate. The configuration of the downlink channels is defined in table E.5.1.
- 4) The information bit data shall be pseudo random and not repeated before 10 different information bit payload blocks are processed. (e.g. Fixed reference Channel Definition H-set 6 (16 QAM): The information bit payload block is 9377 bits long. Hence the PRBS sequence must be at least $9377 * 10$ bits long.) Use a PRBS from ITU-T O.153 Ref [27]
- 5) The SS shall not time the transmission freely. It shall time the transmission strictly according to the reference measurement channels: i.e. Process number is continued exactly after 6 TTIs.
- 6) Setup the fading simulator with fading conditions as described in table D.2.2.1.A and clause D.2.6.

9.2.1G.4.2 Procedure

- 1) Once the HSDPA connection is setup, change levels according to Tables E.5.6 to E.5.8B as specified by table E.5.9 and start transmitting HSDPA Data.
- 2) For all relevant propagation conditions, for all relevant I_{oc} levels, for all relevant E_c/I_{or} , for all relevant \hat{I}_{or}/I_{oc} , for all relevant H-sets in tables 9.2.1G.7 to 9.2.1G.12 count the number of NACK, ACK and statDTX on the UL HS-DPCCH during the test interval and decide pass or fail according to Annex F.6.3 tables F.6.3.5.2.1, F.6.3.5.2.5B and F.6.3.5.2.6B.

9.2.1G.5 Test Requirements

Tables 9.2.1G.7 to 9.2.1G.12 define the primary level settings including test tolerance for all relevant throughput tests. The pass / fail decision for throughput is done according to Annex F.6.3.

Tables E.5.6 to E.5.8B define the secondary and subsequently ranked level settings including test tolerance. As those level settings are not uniform for the throughput tests in this clause, Table E.5.9 indicates which levels are applied, when the primary level settings (E_c/I_{or} and I_{or}/I_{oc}) and propagation conditions (PA3,PB3, VA30, VA 120) vary.

Table 9.2.1G.7: Test Parameters for Testing QPSK FRCs H-Set 6

Parameter	Unit	Test 1	Test 2	Test 3	Test 4	Test 5
Phase reference		P-CPICH				
I_{oc}	dBm/3.84 MHz	-60 (no test tolerance applied)				

Table 9.2.1G.8: Test requirement enhanced requirement type 3 QPSK at $\hat{I}_{or}/I_{oc} = 10$ dB, Fixed Reference Channel (FRC) H-Set 6

Test Number	Propagation Conditions	Reference value	
		HS-PDSCH E_c/I_{or} (dB)	T-put R (kbps) * $\hat{I}_{or}/I_{oc} = 10.6$ dB
1	PA3	-8.9	1554
		-5.9	2495
2	PB3	-8.9	1190
		-5.9	2098
3	VA30	-8.9	1229
		-5.9	2013
4	VA120	-8.9	1060
		-5.9	1674

Table 9.2.1G.9: Test requirement enhanced requirement type 3 QPSK at $\hat{I}_{or}/I_{oc} = 5$ dB, Fixed Reference Channel (FRC) H-Set 6

Test Number	Propagation Conditions	Reference value	
		HS-PDSCH E_c/I_{or} (dB)	T-put R (kbps) * $\hat{I}_{or}/I_{oc} = 5.6$ dB
5	PB3	-5.9	1248
		-2.9	2044

Table 9.2.1G.10: Test Parameters for Testing 16QAM FRCs H-Set 6

Parameter	Unit	Test 1	Test 2	Test 3	Test 4	Test 5
Phase reference		P-CPICH				
I_{oc}	dBm/3.84 MHz	-60 (no test tolerance applied)				

Table 9.2.1G.11: Test requirement enhanced requirement type 3 16QAM at $\hat{I}_{or}/I_{oc} = 10$, Fixed Reference Channel (FRC) H-Set 6

Test Number	Propagation Conditions	Reference value	
		HS-PDSCH E_c/I_{or} (dB)	T-put R (kbps) * $\hat{I}_{or}/I_{oc} = 10.6$ dB
1	PA3	-5.9	1979
		-2.9	3032
2	PB3	-5.9	1619
		-2.9	2464
3	VA30	-5.9	1710
		-2.9	2490
4	VA120	-5.9	1437
		-2.9	2148

Table 9.2.1G.12: Test requirement enhanced requirement type 3 16QAM at $\hat{I}_{or}/I_{oc} = 5$, Fixed Reference Channel (FRC) H-Set 6

Test Number	Propagation Conditions	Reference value	
		HS-PDSCH E_c/I_{or} (dB)	T-put R (kbps) * $\hat{I}_{or}/I_{oc} = 5.6$ dB
5	PB3	-5.9	779
		-2.9	1688

9.2.2 Open Loop Diversity Performance

The test cases in the following sections 9.2.2A to 9.2.2D define the Open Loop Diversity Performance tests for the different H-Sets for the different HS-DSCH Categories as defined in tables 9.2.1, 9.2.2 and 9.2.3.

9.2.2A Open Loop Diversity Performance - QPSK/16QAM, Fixed Reference Channel (FRC) H-Set 1/2/3

9.2.2A.1 Definition and applicability

The receiver open loop transmit diversity performance of the High Speed Physical Downlink Shared Channel (HS-DSCH) in multi-path fading environments are determined by the information bit throughput R .

The requirements and this test apply to Release 5 and later releases for all types of UTRA for FDD UE that support HSDPA UE capability categories 1 to 6.

The requirements and this test apply for Release 6 and later releases to all types of UTRA for the FDD UE that support HSDPA UE capability categories 7 and 8.

9.2.2A.2 Minimum requirements

Requirements for a particular UE belonging to certain HS-DSCH category are determined according to the relevant part of Table 9.2.1.

The requirements are specified in terms of minimum information bit throughput R for the DL reference channels H-set 1/2/3 specified in Annex C.8.1.1, C.8.1.2 and C.8.1.3 respectively, with the addition of the relevant parameters in Tables 9.2.2A.1 and 9.2.2A.3 plus the downlink physical channel setup according to table E.5.2.

Using this configuration the throughput shall meet or exceed the minimum requirements specified in tables 9.2.2A.2 and 9.2.2A.4.

Table 9.2.2A.1: Test Parameters for Testing QPSK FRCs H-Set 1/H-Set 2/H-Set 3

Parameter	Unit	Test 1	Test 2	Test 3
Phase reference		P-CPICH		
I_{oc}	dBm/3.84 MHz	-60		
Redundancy and constellation version coding sequence		{0,2,5,6}		
Maximum number of HARQ transmission		4		
Note:	The HS-SCCH-1 and HS-PDSCH shall be transmitted continuously with constant power. HS-SCCH-1 shall only use the identity of the UE under test for those TTI intended for the UE.			

Table 9.2.2A.2: Minimum requirement QPSK, Fixed Reference Channel (FRC) H-Set 1/2/3

Test Number	Propagation Conditions	Reference value		
		HS-PDSCH E_c/I_{or} (dB)	T-put R (kbps) * $\hat{I}_{or}/I_{oc} = 0$ dB	T-put R (kbps) * $\hat{I}_{or}/I_{oc} = 10$ dB
1	PA3	-6	77	375
		-3	180	475
2	PB3	-6	20	183
		-3	154	274
3	VA30	-6	15	187
		-3	162	284
* Notes: 1) The reference value R is for the Fixed Reference Channel (FRC) H-Set 1 2) For Fixed Reference Channel (FRC) H-Set 2 the reference values for R should be scaled (multiplied by 1.5 and rounding to the nearest integer t-put in kbps, where values of $i+1/2$ are rounded up to $i+1$, i integer) 3) For Fixed Reference Channel (FRC) H-Set 3 the reference values for R should be scaled (multiplied by 3 and rounding to the nearest integer t-put in kbps, where values of $i+1/2$ are rounded up to $i+1$, i integer)				

Table 9.2.2A.3: Test Parameters for Testing 16QAM FRCs H-Set 1/H-Set 2/H-Set 3

Parameter	Unit	Test 1	Test 2	Test 3
Phase reference		P-CPICH		
I_{oc}	dBm/3.84 MHz	-60		
Redundancy and constellation version coding sequence		{6,2,1,5}		
Maximum number of HARQ transmission		4		
Note:	The HS-SCCH-1 and HS-PDSCH shall be transmitted continuously with constant power. HS-SCCH-1 shall only use the identity of the UE under test for those TTI intended for the UE.			

Table 9.2.2A.4: Minimum requirement 16QAM, Fixed Reference Channel (FRC) H-Set 1/2/3

Test Number	Propagation Conditions	Reference value	
		HS-PDSCH E_c/I_{or} (dB)	T-put R (kbps) * $\hat{I}_{or}/I_{oc} = 10$ dB
1	PA3	-6	295
		-3	463
2	PB3	-6	24
		-3	243
3	VA30	-6	35
		-3	251

* Notes: 1) The reference value R is for the Fixed Reference Channel (FRC) H-Set 1
2) For Fixed Reference Channel (FRC) H-Set 2 the reference values for R should be scaled (multiplied by 1.5 and rounding to the nearest integer t-put in kbps, where values of $i+1/2$ are rounded up to $i+1$, i integer)
3) For Fixed Reference Channel (FRC) H-Set 3 the reference values for R should be scaled (multiplied by 3 and rounding to the nearest integer t-put in kbps, where values of $i+1/2$ are rounded up to $i+1$, i integer)

The reference for this requirement is TS 25.101 [1] clauses 9.2.2.1 and 9.2.2.2.

9.2.2A.3 Test purpose

To verify the ability of the receiver to receive a predefined test signal, representing a multi-path fading channel with information bit throughput R not falling below a specified value. The test stresses the multi-code reception and channel decoding with incremental redundancy.

9.2.2A.4 Method of test

9.2.2A.4.1 Initial conditions

Test environment: normal; see clauses G.2.1 and G.2.2.

Frequencies to be tested: mid range; see clause G.2.4.

1. Connect the SS (Node B Emulator) and faders and AWGN noise sources to the UE antenna connector as shown in figure A.12.
2. Set the node B emulator behaviour according to table 9.2.4. Set the test parameters for tests 1-3 according to table 9.2.2A.1 or 9.2.2A.3 and levels according to tables 9.2.2A.6 to 9.2.2A.9. The configuration of the downlink channels is defined in table E.5.2.
3. The information bit data shall be pseudo random and not repeated before 10 different information bit payload blocks are processed. (e.g. Fixed reference Channel Definition H-set 1 (16 QAM): The information bit payload block is 4664 bits long. Hence the PRBS must be at least $4664 * 10$ bits long) Use a PRBS from ITU-T O.153 Ref [27].

4. Setup the fading simulators with fading conditions as described in table D.2.2.1.A and clause D.2.7.

Table 9.2.2A.5: Specific Message Contents for open-loop transmit diversity mode

SYSTEM INFORMATION BLOCK TYPE5

Information Element	Value/remark
PRACH system information list - AICH info - STTD Indicator	TRUE
Secondary CCPCH system information - PICH info - STTD Indicator - Secondary CCPCH info - STTD Indicator	TRUE TRUE
Primary CCPCH info - CHOICE mode - TX Diversity indicator	FDD TRUE

SYSTEM INFORMATION BLOCK TYPE11

Information Element	Value/remark
New intra-frequency cells - Intra-frequency cell id	1
- TX Diversity indicator	TRUE

RRC CONNECTION SETUP

Information Element	Value/remark
Downlink information common for all radio links - CHOICE mode - TX Diversity Mode	FDD STTD
Downlink DPCH info for each RL - CHOICE mode - Downlink DPCH info for each RL - Closed loop timing adjustment mode	FDD 1

RADIO BEARER SETUP for Closed test loop mode1 and HSDPA

Information Element	Value/remark
Downlink information common for all radio links - CHOICE mode - TX Diversity Mode	FDD STTD
Downlink DPCH info for each RL - CHOICE mode - Downlink DPCH info for each RL - Closed loop timing adjustment mode	FDD 1

9.2.2A.4.2 Procedure

1. Set up a HSDPA with looping back 12.2kbps RMC connection according to the generic HSDPA set-up procedure specified in TS 34.108 [3] sub clause 7.3.6 with the exceptions for information elements listed in table 9.2.2A.5, with levels according to table E.5.0.
2. Once the HSDPA connection is setup, change levels according to Tables E.5.6 to E.5.8B as specified by table E.5.9 and start transmitting HSDPA Data.
3. For all relevant propagation conditions, for all relevant Ioc levels, for all relevant Ec/Ior, for all relevant Ior/Ioc, for all relevant H-sets in tables 9.2.2A.6 to 9.2.2A.9 count the number of NACK, ACK and statDTX on the UL HS-DPCCH during the test interval and decide pass or fail according to Annex F.6.3 tables F.6.3.5.3.1 and F.6.3.5.3.2. ACK is counted as a pass. NACK and statDTX are counted as a failure.

9.2.2A.5 Test Requirements

Tables 9.2.2A.6 to 9.2.2A.9 define the primary level settings including test tolerance and test parameters for all relevant throughput tests. The pass / fail decision for throughput is done according to Annex F.6.3.

Tables E.5.6 to E.5.8B define the secondary and subsequently ranked level settings including test tolerance. As those level settings are not uniform for the throughput tests in this clause, Table E.5.9 indicates which levels are applied, when the primary level settings (E_c/I_{or} and I_{or}/I_{oc}) and propagation conditions (PA3, PB3, VA30, VA 120) vary.

Note that the levels in tables E.5.6 to E.5.8B, when applied in this subclause (open loop transmit diversity) are equal to the sum of the levels at both antennas. They are equally divided between both antennas according to Table E.5.2: column Note.

Table 9.2.2A.6: Test Parameters for Testing QPSK FRCs H-Set 1/H-Set 2/H-Set 3

Parameter	Unit	Test 1	Test 2	Test 3
Phase reference		P-CPICH		
I_{oc}	dBm/3.84 MHz	-60 (no test tolerance applied)		

Table 9.2.2A.7: Test requirement QPSK, Fixed Reference Channel (FRC) H-Set 1/2/3

Test Number	Propagation Conditions	Reference value		
		HS-PDSCH E_c/I_{or} (dB)	T-put R (kbps) * $\hat{I}_{or}/I_{oc} = 0.8$ dB	T-put R (kbps) * $\hat{I}_{or}/I_{oc} = 10.8$ dB
1	PA3	-5.9	77	375
		-2.9	180	475
2	PB3	-5.9	20	183
		-2.9	154	274
3	VA30	-5.9	15	187
		-2.9	162	284

* Notes: 1) The reference value R is for the Fixed Reference Channel (FRC) H-Set 1
2) For Fixed Reference Channel (FRC) H-Set 2 the reference values for R should be scaled (multiplied by 1.5 and rounding to the nearest integer t-put in kbps, where values of $i+1/2$ are rounded up to $i+1$, i integer)
3) For Fixed Reference Channel (FRC) H-Set 3 the reference values for R should be scaled (multiplied by 3 and rounding to the nearest integer t-put in kbps, where values of $i+1/2$ are rounded up to $i+1$, i integer)

Table 9.2.2A.8: Test Parameters for Testing 16QAM FRCs H-Set 1/H-Set 2/H-Set 3

Parameter	Unit	Test 1	Test 2	Test 3
Phase reference		P-CPICH		
I_{oc}	dBm/3.84 MHz	-60 (no test tolerance applied)		

Table 9.2.2A.9: Test requirement 16QAM, Fixed Reference Channel (FRC) H-Set 1/2/3

Test Number	Propagation Conditions	Reference value	
		HS-PDSCH E_c/I_{or} (dB)	T-put R (kbps) * $\hat{I}_{or}/I_{oc} = 10.8$ dB
1	PA3	-5.9	295
		-2.9	463
2	PB3	-5.9	24
		-2.9	243
3	VA30	-5.9	35
		-2.9	251

* Notes: 1) The reference value R is for the Fixed Reference Channel (FRC) H-Set 1
2) For Fixed Reference Channel (FRC) H-Set 2 the reference values for R should be scaled (multiplied by 1.5 and rounding to the nearest integer t-put in kbps, where values of $i+1/2$ are rounded up to $i+1$, i integer)
3) For Fixed Reference Channel (FRC) H-Set 3 the reference values for R should be scaled (multiplied by 3 and rounding to the nearest integer t-put in kbps, where values of $i+1/2$ are rounded up to $i+1$, i integer)

NOTE: If the above Test Requirement differs from the Minimum Requirement then the Test Tolerance applied for this test is non-zero. The Test Tolerance for this test is defined in clause F.2 and the explanation of how the Minimum Requirement has been relaxed by the Test Tolerance is given in clause F.4.

9.2.2B Open Loop Diversity Performance - QPSK, Fixed Reference Channel (FRC) H-Set 4/5

9.2.2B.1 Definition and applicability

The receiver open loop transmit diversity performance of the High Speed Physical Downlink Shared Channel (HS-DSCH) in multi-path fading environments are determined by the information bit throughput R .

The requirements and this test apply to Release 5 and later releases for all types of UTRA for FDD UE that support HSDPA UE capability categories 11 and 12.

9.2.2B.2 Minimum requirements

Requirements for a particular UE belonging to certain HS-DSCH category are determined according to the relevant part of Table 9.2.1.

The requirements are specified in terms of minimum information bit throughput R for the DL reference channels H-set 4/5 specified in Annex C.8.1.4 and C.8.1.5 respectively, with the addition of the relevant parameters in Table 9.2.2B.1 plus the downlink physical channel setup according to table E.5.2.

Using this configuration the throughput shall meet or exceed the minimum requirements specified in tables 9.2.2B.2 and 9.2.2B.3.

Table 9.2.2B.1: Test Parameters for Testing QPSK FRCs H-Set 4/H-Set 5

Parameter	Unit	Test 1	Test 2	Test 3
Phase reference		P-CPICH		
I_{oc}	dBm/3.84 MHz	-60		
Redundancy and constellation version coding sequence		{0,2,5,6}		
Maximum number of HARQ transmission		4		
Note:	The HS-SCCH-1 and HS-PDSCH shall be transmitted continuously with constant power. HS-SCCH-1 shall only use the identity of the UE under test for those TTI intended for the UE.			

Table 9.2.2B.2: Minimum requirement QPSK, Fixed Reference Channel (FRC) H-Set 4

Test Number	Propagation Conditions	Reference value		
		HS-PDSCH E_c/I_{or} (dB)	T-put R (kbps) * $\hat{I}_{or}/I_{oc} = 0$ dB	T-put R (kbps) * $\hat{I}_{or}/I_{oc} = 10$ dB
1	PA3	-6	70	369
		-3	171	471
2	PB3	-6	14	180
		-3	150	276
3	VA30	-6	11	184
		-3	156	285

* Note: The reference value R is for the Fixed Reference Channel (FRC) H-Set 4

Table 9.2.2B.3: Minimum requirement QPSK, Fixed Reference Channel (FRC) H-Set 5

Test Number	Propagation Conditions	Reference value		
		HS-PDSCH E_c/I_{or} (dB)	T-put R (kbps) * $\hat{I}_{or}/I_{oc} = 0$ dB	T-put R (kbps) * $\hat{I}_{or}/I_{oc} = 10$ dB
1	PA3	-6	116	563
		-3	270	713
2	PB3	-6	30	275
		-3	231	411
3	VA30	-6	23	281
		-3	243	426

* Note: The reference value R is for the Fixed Reference Channel (FRC) H-Set 5

The reference for this requirement is TS 25.101 [1] clause 9.2.2.3.

9.2.2B.3 Test purpose

To verify the ability of the receiver to receive a predefined test signal, representing a multi-path fading channel with information bit throughput R not falling below a specified value. The test stresses the multi-code reception and channel decoding with incremental redundancy.

9.2.2B.4 Method of test

9.2.2B.4.1 Initial conditions

Test environment: normal; see clauses G.2.1 and G.2.2.

Frequencies to be tested: mid range; see clause G.2.4.

1. Connect the SS (Node B Emulator) and faders and AWGN noise sources to the UE antenna connector as shown in figure A.12.
2. Set the node B emulator behaviour according to table 9.2.4. Set the test parameters for tests 1-3 according to table 9.2.2B.1 and levels according to tables 9.2.2B.5 to 9.2.2B.7. The configuration of the downlink channels is defined in table E.5.2.
3. The information bit data shall be pseudo random and not repeated before 10 different information bit payload blocks are processed. (e.g. Fixed reference Channel Definition H-set 1 (16 QAM): The information bit payload block is 4664 bits long. Hence the PRBS must be at least $4664 * 10$ bits long) Use a PRBS from ITU-T O.153 Ref [27].
4. Setup the fading simulators with fading conditions as described in table D.2.2.1.A and clause D.2.7.

Table 9.2B.4: Specific Message Contents for open-loop transmit diversity mode

SYSTEM INFORMATION BLOCK TYPE5

Information Element	Value/remark
PRACH system information list - AICH info - STTD Indicator	TRUE
Secondary CCPCH system information - PICH info - STTD Indicator - Secondary CCPCH info - STTD Indicator	TRUE TRUE
Primary CCPCH info - CHOICE mode - TX Diversity indicator	FDD TRUE

SYSTEM INFORMATION BLOCK TYPE11

Information Element	Value/remark
New intra-frequency cells - Intra-frequency cell id	1
- TX Diversity indicator	TRUE

RRC CONNECTION SETUP

Information Element	Value/remark
Downlink information common for all radio links - CHOICE mode - TX Diversity Mode	FDD STTD
Downlink DPCH info for each RL - CHOICE mode - Downlink DPCH info for each RL - Closed loop timing adjustment mode	FDD 1

RADIO BEARER SETUP for Closed test loop mode1 and HSDPA

Information Element	Value/remark
Downlink information common for all radio links - CHOICE mode - TX Diversity Mode	FDD STTD
Downlink DPCH info for each RL - CHOICE mode - Downlink DPCH info for each RL - Closed loop timing adjustment mode	FDD 1

9.2.2B.4.2 Procedure

1. Set up a HSDPA connection with looping back 12.2kbps RMC according to the generic HSDPA set-up procedure specified in TS 34.108 [3] sub clause 7.3.6 with the exceptions for information elements listed in table 9.2.2B.4, with levels according to table E.5.0.
2. Once the HSDPA connection is setup, change levels according to Tables E.5.6 to E.5.8B as specified by table E.5.9 and start transmitting HSDPA Data.
3. For all relevant propagation conditions, for all relevant I_{oc} levels, for all relevant E_c/I_{or} , for all relevant \hat{I}_{or}/I_{oc} , for all relevant H-sets in tables 9.2.2B.5 to 9.2.2B.7 count the number of NACK, ACK and statDTX on the UL HS-DPCCH during the test interval and decide pass or fail according to Annex F.6.3 tables F.6.3.5.3.3 and F.6.3.5.3.4. ACK is counted as a pass. NACK and statDTX are counted as a failure.

9.2.2B.5 Test Requirements

Tables 9.2.2B.5 to 9.2.2B.7 define the primary level settings including test tolerance and test parameters for all relevant throughput tests. The pass / fail decision for throughput is done according to Annex F.6.3.

Tables E.5.6 to E.5.8B define the secondary and subsequently ranked level settings including test tolerance. As those level settings are not uniform for the throughput tests in this clause, Table E.5.9 indicates which levels are applied, when the primary level settings (E_c/I_{or} and I_{or}/I_{oc}) and propagation conditions (PA3, PB3, VA30, VA 120) vary.

Note that the levels in tables E.5.6 to E.5.8B, when applied in this subclause (open loop transmit diversity) are equal to the sum of the levels at both antennas. They are equally divided between both antennas according to Table E.5.2: column Note.

Table 9.2.2B.5: Test Parameters for Testing QPSK FRCs H-Set 4/H-Set 5

Parameter	Unit	Test 1	Test 2	Test 3
Phase reference		P-CPICH		
I_{oc}	dBm/3.84 MHz	-60 (no test tolerance applied)		

Table 9.2.2B.6: Test requirement QPSK, Fixed Reference Channel (FRC) H-Set 4

Test Number	Propagation Conditions	Reference value		
		HS-PDSCH E_c/I_{or} (dB)	T-put R (kbps) * $\hat{I}_{or}/I_{oc} = 0.8$ dB	T-put R (kbps) * $\hat{I}_{or}/I_{oc} = 10.8$ dB
1	PA3	-5.9	70	369
		-2.9	171	471
2	PB3	-5.9	14	180
		-2.9	150	276
3	VA30	-5.9	11	184
		-2.9	156	285

* Note: The reference value R is for the Fixed Reference Channel (FRC) H-Set 4

Table 9.2.2B.7: Test requirement QPSK, Fixed Reference Channel (FRC) H-Set 5

Test Number	Propagation Conditions	Reference value		
		HS-PDSCH E_c/I_{or} (dB)	T-put R (kbps) * $\hat{I}_{or}/I_{oc} = 0.8$ dB	T-put R (kbps) * $\hat{I}_{or}/I_{oc} = 10.8$ dB
1	PA3	-5.9	116	563
		-2.9	270	713
2	PB3	-5.9	30	275
		-2.9	231	411
3	VA30	-5.9	23	281
		-2.9	243	426

* Note: The reference value R is for the Fixed Reference Channel (FRC) H-Set 5

NOTE: If the above Test Requirement differs from the Minimum Requirement then the Test Tolerance applied for this test is non-zero. The Test Tolerance for this test is defined in clause F.2 and the explanation of how the Minimum Requirement has been relaxed by the Test Tolerance is given in clause F.4.

9.2.2C Open Loop Diversity Performance - Enhanced Performance Requirements Type 1 - QPSK/16QAM, Fixed Reference Channel (FRC) H-Set 1/2/3

9.2.2C.1 Definition and applicability

The receiver open loop transmit diversity performance of the High Speed Physical Downlink Shared Channel (HS-DSCH) in multi-path fading environments are determined by the information bit throughput R.

The requirements and this test apply for Release 6 and later releases to all types of UTRA for the FDD UE that support HSDPA UE capability categories 1 to 8 and the optional enhanced performance requirements type 1.

9.2.2C.2 Minimum requirements

Requirements for a particular UE belonging to certain HS-DSCH category are determined according to the relevant parts of Table 9.2.2.1

The requirements are specified in terms of minimum information bit throughput R for the DL reference channels H-set 1/2/3 specified in Annex C.8.1.1, C.8.1.2 and C.8.1.3 respectively, with the addition of the relevant parameters in Tables 9.2.2C.1 and 9.2.2C.3 plus the downlink physical channel setup according to table E.5.2.

Using this configuration the throughput shall meet or exceed the minimum requirements specified in tables 9.2.2C.2 and 9.2.2C.4.

Table 9.2.2C.1: Test Parameters for Testing QPSK FRCs H-Set 1/H-Set 2/H-Set 3

Parameter	Unit	Test 1	Test 2	Test 3
Phase reference		P-CPICH		
I_{oc}	dBm/3.84 MHz	-60		
Redundancy and constellation version coding sequence		{0,2,5,6}		
Maximum number of HARQ transmission		4		
Note:	The HS-SCCH-1 and HS-PDSCH shall be transmitted continuously with constant power. HS-SCCH-1 shall only use the identity of the UE under test for those TTI intended for the UE.			

Table 9.2.2C.2: Minimum requirement Enhanced requirement type 1, QPSK, Fixed Reference Channel (FRC) H-Set 1/2/3

Test Number	Propagation Conditions	Reference value		
		HS-PDSCH E_c / I_{or} (dB)	T-put R (kbps) * $\hat{I}_{or} / I_{oc} = 0$ dB	T-put R (kbps) * $\hat{I}_{or} / I_{oc} = 10$ dB
1	PA3	-12	N/A	268
		-9	N/A	407
		-6	197	N/A
		-3	333	N/A
2	PB3	-9	N/A	183
		-6	152	288
		-3	251	N/A
3	VA30	-9	N/A	197
		-6	164	307
		-3	261	N/A
* Notes: 1) The reference value R is for the Fixed Reference Channel (FRC) H-Set 1 2) For Fixed Reference Channel (FRC) H-Set 2 the reference values for R should be scaled (multiplied by 1.5 and rounding to the nearest integer t-put in kbps, where values of $i+1/2$ are rounded up to $i+1$, i integer) 3) For Fixed Reference Channel (FRC) H-Set 3 the reference values for R should be scaled (multiplied by 3 and rounding to the nearest integer t-put in kbps, where values of $i+1/2$ are rounded up to $i+1$, i integer)				

Table 9.2.2C.3: Test Parameters for Testing 16QAM FRCs H-Set 1/H-Set 2/H-Set 3

Parameter	Unit	Test 1	Test 2	Test 3
Phase reference		P-CPICH		
I_{oc}	dBm/3.84 MHz	-60		
Redundancy and constellation version coding sequence		{6,2,1,5}		
Maximum number of HARQ transmission		4		
Note:	The HS-SCCH-1 and HS-PDSCH shall be transmitted continuously with constant power. HS-SCCH-1 shall only use the identity of the UE under test for those TTI intended for the UE.			

Table 9.2.2C.4: Minimum requirement Enhanced requirement type 1, 16QAM, Fixed Reference Channel (FRC) H-Set 1/2/3

Test Number	Propagation Conditions	Reference value	
		HS-PDSCH E_c / I_{or} (dB)	T-put R (kbps) * $\hat{I}_{or} / I_{oc} = 10$ dB
1	PA3	-9	340
		-6	513
2	PB3	-6	251
		-3	374
3	VA30	-6	280
		-3	398

* Notes: 1)The reference value R is for the Fixed Reference Channel (FRC) H-Set 1
2) For Fixed Reference Channel (FRC) H-Set 2 the reference values for R should be scaled (multiplied by 1.5 and rounding to the nearest integer t-put in kbps, where values of $i+1/2$ are rounded up to $i+1$, i integer)
3) For Fixed Reference Channel (FRC) H-Set 3 the reference values for R should be scaled (multiplied by 3 and rounding to the nearest integer t-put in kbps, where values of $i+1/2$ are rounded up to $i+1$, i integer)

The reference for this requirement is TS 25.101 [1] clauses 9.2.2.1 and 9.2.2.2.

9.2.2C.3 Test purpose

To verify the ability of the receiver to receive a predefined test signal, representing a multi-path fading channel with information bit throughput R not falling below a specified value. The test stresses the multi-code reception and channel decoding with incremental redundancy.

9.2.2C.4 Method of test

9.2.2C.4.1 Initial conditions

Test environment: normal; see clauses G.2.1 and G.2.2.

Frequencies to be tested: mid range; see clause G.2.4.

1. Connect the SS (Node B Emulator) and faders and AWGN noise sources to the UE antenna connector as shown in figure A.22 for UEs that support receive diversity or figure A.12 for UEs that do not support receive diversity.
2. Set the node B emulator behaviour according to table 9.2.4. Set the test parameters for tests 1-3 according to table 9.2.2C.1 or 9.2.2C.3 and levels according to tables 9.2.2C.6 to 9.2.2C.9. The configuration of the downlink channels is defined in table E.5.2.
3. The information bit data shall be pseudo random and not repeated before 10 different information bit payload blocks are processed. (e.g. Fixed reference Channel Definition H-set 1 (16 QAM): The information bit payload block is 4664 bits long. Hence the PRBS must be at least $4664 * 10$ bits long) Use a PRBS from ITU-T O.153 Ref [27].

4. Setup the fading simulators with fading conditions as described in table D.2.2.1.A and clause D.2.5.

Table 9.2.2C.5: Specific Message Contents for open-loop transmit diversity mode

SYSTEM INFORMATION BLOCK TYPE5

Information Element	Value/remark
PRACH system information list - AICH info - STTD Indicator	TRUE
Secondary CCPCH system information - PICH info - STTD Indicator - Secondary CCPCH info - STTD Indicator	TRUE TRUE
Primary CCPCH info - CHOICE mode - TX Diversity indicator	FDD TRUE

SYSTEM INFORMATION BLOCK TYPE11

Information Element	Value/remark
New intra-frequency cells - Intra-frequency cell id	1
- TX Diversity indicator	TRUE

RRC CONNECTION SETUP

Information Element	Value/remark
Downlink information common for all radio links - CHOICE mode - TX Diversity Mode	FDD STTD
Downlink DPCH info for each RL - CHOICE mode - Downlink DPCH info for each RL - Closed loop timing adjustment mode	FDD 1

RADIO BEARER SETUP for Closed test loop mode1 and HSDPA

Information Element	Value/remark
Downlink information common for all radio links - CHOICE mode - TX Diversity Mode	FDD STTD
Downlink DPCH info for each RL - CHOICE mode - Downlink DPCH info for each RL - Closed loop timing adjustment mode	FDD 1

9.2.2C.4.2 Procedure

1. Set up a HSDPA connection with looping back 12.2kbps RMC according to the generic HSDPA set-up procedure specified in TS 34.108 [3] sub clause 7.3.6 with the exceptions for information elements listed in table 9.2.2C.5, with levels according to table E.5.0.
2. Once the HSDPA connection is setup, change levels according to Tables E.5.6 to E.5.8B as specified by table E.5.9 and start transmitting HSDPA Data.
3. For all relevant propagation conditions, for all relevant Ioc levels, for all relevant Ec/Ior, for all relevant Ior/Ioc, for all relevant H-sets in tables 9.2.2C.6 to 9.2.2C.9 count the number of NACK, ACK and statDTX on the UL HS-DPCCH during the test interval and decide pass or fail according to Annex F.6.3 tables F.6.3.5.3.5 and F.6.3.5.3.6. ACK is counted as a pass. NACK and statDTX are counted as a failure.

9.2.2C.5 Test Requirements

Tables 9.2.2C.6 to 9.2.2C.9 define the primary level settings including test tolerance and test parameters for all relevant throughput tests. The pass / fail decision for throughput is done according to Annex F.6.3.

Tables E.5.6 to E.5.8B define the secondary and subsequently ranked level settings including test tolerance. As those level settings are not uniform for the throughput tests in this clause, Table E.5.9 indicates which levels are applied, when the primary level settings (E_c/I_{or} and I_{or}/I_{oc}) and propagation conditions (PA3, PB3, VA30, VA 120) vary.

Note that the levels in tables E.5.6 to E.5.8B, when applied in this subclause (open loop transmit diversity) are equal to the sum of the levels at both antennas. They are equally divided between both antennas according to Table E.5.2: column Note.

Table 9.2.2C.6: Test Parameters for Testing QPSK FRCs H-Set 1/H-Set 2/H-Set 3

Parameter	Unit	Test 1	Test 2	Test 3
Phase reference		P-CPICH		
I_{oc}	dBm/3.84 MHz	-60 (no test tolerance applied)		

Table 9.2.2C.7: Test requirement Enhanced requirement type 1, QPSK, Fixed Reference Channel (FRC) H-Set 1/2/3

Test Number	Propagation Conditions	Reference value		
		HS-PDSCH E_c / I_{or} (dB)	T-put R (kbps) * $\hat{I}_{or} / I_{oc} = 0.8$ dB	T-put R (kbps) * $\hat{I}_{or} / I_{oc} = 10.8$ dB
1	PA3	-11.9	N/A	268
		-8.9	N/A	407
		-5.9	197	N/A
		-2.9	333	N/A
2	PB3	-8.9	N/A	183
		-5.9	152	288
		-2.9	251	N/A
3	VA30	-8.9	N/A	197
		-5.9	164	307
		-2.9	261	N/A

* Notes: 1) The reference value R is for the Fixed Reference Channel (FRC) H-Set 1
2) For Fixed Reference Channel (FRC) H-Set 2 the reference values for R should be scaled (multiplied by 1.5 and rounding to the nearest integer t-put in kbps, where values of $i+1/2$ are rounded up to $i+1$, i integer)
3) For Fixed Reference Channel (FRC) H-Set 3 the reference values for R should be scaled (multiplied by 3 and rounding to the nearest integer t-put in kbps, where values of $i+1/2$ are rounded up to $i+1$, i integer)

Table 9.2.2C.8: Test Parameters for Testing 16QAM FRCs H-Set 1/H-Set 2/H-Set 3

Parameter	Unit	Test 1	Test 2	Test 3
Phase reference		P-CPICH		
I_{oc}	dBm/3.84 MHz	-60 (no test tolerance applied)		

Table 9.2.2C.9: Test requirement Enhanced requirement type 1, 16QAM, Fixed Reference Channel (FRC) H-Set 1/2/3

Test Number	Propagation Conditions	Reference value	
		HS-PDSCH E_c / I_{or} (dB)	T-put R (kbps) * $\hat{I}_{or} / I_{oc} = 10.8$ dB
1	PA3	-8.9	340
		-5.9	513
2	PB3	-5.9	251
		-2.9	374
3	VA30	-5.9	280
		-2.9	398

* Notes: 1) The reference value R is for the Fixed Reference Channel (FRC) H-Set 1
2) For Fixed Reference Channel (FRC) H-Set 2 the reference values for R should be scaled (multiplied by 1.5 and rounding to the nearest integer t-put in kbps, where values of $i+1/2$ are rounded up to $i+1$, i integer)
3) For Fixed Reference Channel (FRC) H-Set 3 the reference values for R should be scaled (multiplied by 3 and rounding to the nearest integer t-put in kbps, where values of $i+1/2$ are rounded up to $i+1$, i integer)

NOTE: If the above Test Requirement differs from the Minimum Requirement then the Test Tolerance applied for this test is non-zero. The Test Tolerance for this test is defined in clause F.2 and the explanation of how the Minimum Requirement has been relaxed by the Test Tolerance is given in clause F.4.

9.2.2D Open Loop Diversity Performance - Enhanced Performance Requirements Type 2 - QPSK/16QAM, Fixed Reference Channel (FRC) H-Set 3

9.2.2D.1 Definition and applicability

The receiver open loop transmit diversity performance of the High Speed Physical Downlink Shared Channel (HS-DSCH) in multi-path fading environments are determined by the information bit throughput R .

The requirements and this test apply to Release 6 and later releases for all types of UTRA for FDD UE that support HSDPA UE capability categories 7 and 8 and the optional enhanced performance requirements type 2.

9.2.2D.2 Minimum requirements

Requirements for a particular UE belonging to certain HS-DSCH category are determined according to the relevant part of Table 9.2.1.

The requirements are specified in terms of minimum information bit throughput R for the DL reference channels H-set 3 specified in Annex C.8.1.3, with the addition of the relevant parameters in Tables 9.2.2D.1 and 9.2.2D.3 plus the downlink physical channel setup according to table E.5.2.

Using this configuration the throughput shall meet or exceed the minimum requirements specified in tables 9.2.2D.2 and 9.2.2D.4.

Table 9.2.2D.1: Test Parameters for Testing QPSK FRCs H-Set 3

Parameter	Unit	Test 1	Test 2	Test 3
Phase reference		P-CPICH		
I_{oc}	dBm/3.84 MHz	-60		
Redundancy and constellation version coding sequence		{0,2,5,6}		
Maximum number of HARQ transmission		4		
Note:	The HS-SCCH-1 and HS-PDSCH shall be transmitted continuously with constant power. HS-SCCH-1 shall only use the identity of the UE under test for those TTI intended for the UE.			

Table 9.2.2D.2: Minimum requirement Enhanced performance requirements Type 2, QPSK, Fixed Reference Channel (FRC) H-Set 3

Test Number	Propagation Conditions	Reference value		
		HS-PDSCH E_c/I_{or} (dB)	T-put R (kbps) * $\hat{I}_{or}/I_{oc} = 0$ dB	T-put R (kbps) * $\hat{I}_{or}/I_{oc} = 10$ dB
1	PA3	-6	77	375
		-3	180	475
2	PB3	-6	20	183
		-3	154	274
3	VA30	-6	15	187
		-3	162	284

* Notes: 1) The reference value R is for the Fixed Reference Channel (FRC) H-Set 1, for Fixed Reference Channel (FRC) H-Set 3 the reference values for R should be scaled (multiplied by 3 and rounding to the nearest integer t-put in kbps, where values of $i+1/2$ are rounded up to $i+1$, i integer)

Table 9.2.2D.3: Test Parameters for Testing 16QAM FRCs H-Set 3

Parameter	Unit	Test 1	Test 2	Test 3
Phase reference		P-CPICH		
I_{oc}	dBm/3.84 MHz	-60		
Redundancy and constellation version coding sequence		{6,2,1,5}		
Maximum number of HARQ transmission		4		
Note:	The HS-SCCH-1 and HS-PDSCH shall be transmitted continuously with constant power. HS-SCCH-1 shall only use the identity of the UE under test for those TTI intended for the UE.			

Table 9.2.2D.4: Minimum requirement Enhanced performance requirements Type 2, 16QAM, Fixed Reference Channel (FRC) H-Set 3

Test Number	Propagation Conditions	Reference value	
		HS-PDSCH E_c/I_{or} (dB)	T-put R (kbps) * $\hat{I}_{or}/I_{oc} = 10$ dB
1	PA3	-6	295
		-3	463
2	PB3	-6	24
		-3	243
3	VA30	-6	35
		-3	251

* Notes: 1) The reference value R is for the Fixed Reference Channel (FRC) H-Set 1, for Fixed Reference Channel (FRC) H-Set 3 the reference values for R should be scaled (multiplied by 3 and rounding to the nearest integer t-put in kbps, where values of $i+1/2$ are rounded up to $i+1$, i integer)

The reference for this requirement is TS 25.101 [1] clauses 9.2.2.1 and 9.2.2.2.

9.2.2D.3 Test purpose

To verify the ability of the receiver to receive a predefined test signal, representing a multi-path fading channel with information bit throughput R not falling below a specified value. The test stresses the multi-code reception and channel decoding with incremental redundancy.

9.2.2D.4 Method of test

9.2.2D.4.1 Initial conditions

Test environment: normal; see clauses G.2.1 and G.2.2.

Frequencies to be tested: mid range; see clause G.2.4.

1. Connect the SS (Node B Emulator) and faders and AWGN noise sources to the UE antenna connector as shown in figure A.12.
2. Set the node B emulator behaviour according to table 9.2.4. Set the test parameters for tests 1-3 according to table 9.2.2D.1 or 9.2.2D.3 and levels according to tables 9.2.2D.6 to 9.2.2D.9. The configuration of the downlink channels is defined in table E.5.2.
3. The information bit data shall be pseudo random and not repeated before 10 different information bit payload blocks are processed. (e.g. Fixed reference Channel Definition H-set 1 (16 QAM): The information bit payload block is 4664 bits long. Hence the PRBS must be at least $4664 * 10$ bits long) Use a PRBS from ITU-T O.153 Ref [27].
4. Setup the fading simulators with fading conditions as described in table D.2.2.1.A and clause D.2.7.

Table 9.2.2D.5: Specific Message Contents for open-loop transmit diversity mode

SYSTEM INFORMATION BLOCK TYPE5

Information Element	Value/remark
PRACH system information list - AICH info - STTD Indicator	TRUE
Secondary CCPCH system information - PICH info - STTD Indicator - Secondary CCPCH info - STTD Indicator	TRUE TRUE
Primary CCPCH info - CHOICE mode - TX Diversity indicator	FDD TRUE

SYSTEM INFORMATION BLOCK TYPE11

Information Element	Value/remark
New intra-frequency cells - Intra-frequency cell id	1
- TX Diversity indicator	TRUE

RRC CONNECTION SETUP

Information Element	Value/remark
Downlink information common for all radio links - CHOICE mode - TX Diversity Mode	FDD STTD
Downlink DPCH info for each RL - CHOICE mode - Downlink DPCH info for each RL - Closed loop timing adjustment mode	FDD 1

RADIO BEARER SETUP for Closed test loop mode1 and HSDPA

Information Element	Value/remark
Downlink information common for all radio links - CHOICE mode - TX Diversity Mode	FDD STTD
Downlink DPCH info for each RL - CHOICE mode - Downlink DPCH info for each RL - Closed loop timing adjustment mode	FDD 1

9.2.2D.4.2 Procedure

1. Set up a HSDPA connection with looping back 12.2kbps RMC according to the generic HSDPA set-up procedure specified in TS 34.108 [3] sub clause 7.3.6 with the exceptions for information elements listed in table 9.2.2D.5, with levels according to table E.5.0.
2. Once the HSDPA connection is setup, change levels according to Tables E.5.6 to E.5.8B as specified by table E.5.9 and start transmitting HSDPA Data.
3. For all relevant propagation conditions, for all relevant I_{oc} levels, for all relevant E_c/I_{or} , for all relevant \hat{I}_{or}/I_{oc} , for all relevant H-sets in tables 9.2.2D.6 to 9.2.2D.9 count the number of NACK, ACK and statDTX on the UL HS-DPCCH during the test interval and decide pass or fail according to Annex F.6.3 tables F.6.3.5.3.1 and F.6.3.5.3.2. ACK is counted as a pass. NACK and statDTX are counted as a failure.

9.2.2D.5 Test Requirements

Tables 9.2.2D.6 to 9.2.2D.9 define the primary level settings including test tolerance and test parameters for all relevant throughput tests. The pass / fail decision for throughput is done according to Annex F.6.3.

Tables E.5.6 to E.5.8B define the secondary and subsequently ranked level settings including test tolerance. As those level settings are not uniform for the throughput tests in this clause, Table E.5.9 indicates which levels are applied, when the primary level settings (E_c/I_{or} and I_{or}/I_{oc}) and propagation conditions (PA3,PB3, VA30, VA 120) vary.

Note that the levels in tables E.5.6 to E.5.8B, when applied in this subclause (open loop transmit diversity) are equal to the sum of the levels at both antennas. They are equally divided between both antennas according to Table E.5.2: column Note.

Table 9.2.2D.6: Test Parameters for Testing QPSK FRCs H-Set 3

Parameter	Unit	Test 1	Test 2	Test 3
Phase reference		P-CPICH		
I_{oc}	dBm/3.84 MHz	-60 (no test tolerance applied)		

Table 9.2.2D.7: Test requirement Enhanced performance requirements Type 2, QPSK, Fixed Reference Channel (FRC) H-Set 3

Test Number	Propagation Conditions	Reference value		
		HS-PDSCH E_c/I_{or} (dB)	T-put R (kbps) * $\hat{I}_{or}/I_{oc} = 0.8$ dB	T-put R (kbps) * $\hat{I}_{or}/I_{oc} = 10.8$ dB
1	PA3	-5.9	77	375
		-2.9	180	475
2	PB3	-5.9	20	183
		-2.9	154	274
3	VA30	-5.9	15	187
		-2.9	162	284

* Notes: 1) The reference value R is for the Fixed Reference Channel (FRC) H-Set 1, for Fixed Reference Channel (FRC) H-Set 3 the reference values for R should be scaled (multiplied by 3 and rounding to the nearest integer t-put in kbps, where values of $i+1/2$ are rounded up to $i+1$, i integer)

Table 9.2.2D.8: Test Parameters for Testing 16QAM FRCs H-Set 3

Parameter	Unit	Test 1	Test 2	Test 3
Phase reference		P-CPICH		
I_{oc}	dBm/3.84 MHz	-60 (no test tolerance applied)		

Table 9.2.2D.9: Test requirement Enhanced performance requirements Type 2, 16QAM, Fixed Reference Channel (FRC) H-Set 3

Test Number	Propagation Conditions	Reference value	
		HS-PDSCH E_c/I_{or} (dB)	T-put R (kbps) * $\hat{I}_{or}/I_{oc} = 10.8$ dB
1	PA3	-5.9	295
		-2.9	463
2	PB3	-5.9	24
		-2.9	243
3	VA30	-5.9	35
		-2.9	251

* Notes: 1) The reference value R is for the Fixed Reference Channel (FRC) H-Set 1, for Fixed Reference Channel (FRC) H-Set 3 the reference values for R should be scaled (multiplied by 3 and rounding to the nearest integer t-put in kbps, where values of $i+1/2$ are rounded up to $i+1$, i integer)

NOTE: If the above Test Requirement differs from the Minimum Requirement then the Test Tolerance applied for this test is non-zero. The Test Tolerance for this test is defined in clause F.2 and the explanation of how the Minimum Requirement has been relaxed by the Test Tolerance is given in clause F.4.

9.2.3 Closed Loop Diversity Performance

The test cases in the following sections 9.2.3A to 9.2.3D define the Closed Loop Diversity Performance tests for the different H-Sets for the different HS-DSCH Categories as defined in tables 9.2.1, 9.2.2 and 9.2.3.

9.2.3A Closed Loop Diversity Performance - QPSK/16QAM, Fixed Reference Channel (FRC) H-Set 1/2/3

9.2.3A.1 Definition and applicability

The receiver closed loop transmit diversity performance of the High Speed Physical Downlink Shared Channel (HS-DSCH) in multi-path fading environments are determined by the information bit throughput R .

The requirements and this test apply to Release 5 and later releases for all types of UTRA for FDD UE that support HSDPA UE capability categories 1 to 6.

The requirements and this test apply for Release 6 and later releases to all types of UTRA for the FDD UE that support HSDPA UE capability categories 7 and 8.

9.2.3A.2 Minimum requirements

Requirements for a particular UE belonging to certain HS-DSCH category are determined according to the relevant part of Table 9.2.1.

The requirements are specified in terms of minimum information bit throughput R for the DL reference channels H-set 1/2/3 specified in Annex C.8.1.1, C.8.1.2 and C.8.1.3 respectively, with the addition of the relevant parameters in tables 9.2.3A.1 and 9.2.3A.3 plus the downlink physical channel setup according to table E.5.3.

Using this configuration the throughput shall meet or exceed the minimum requirements specified in tables 9.2.3A.2 and 9.2.3A.4.

Table 9.2.3A.1: Test Parameters for Testing QPSK FRCs H-Set 1/H-Set 2/H-Set 3

Parameter	Unit	Test 1	Test 2	Test 3
Phase reference		P-CPICH		
I_{oc}	dBm/3.84 MHz	-60		
DPCH frame offset ($\tau_{DPCH,n}$)	Chip	0		
Redundancy and constellation version coding sequence		{0,2,5,6}		
Maximum number of HARQ transmission		4		
Feedback Error Ratio	%	4		
Closed loop timing adjustment mode		1		
Note: The HS-SCCH-1 and HS-PDSCH shall be transmitted continuously with constant power. HS-SCCH-1 shall only use the identity of the UE under test for those TTI intended for the UE.				

Table 9.2.3A.2: Minimum requirement QPSK, Fixed Reference Channel (FRC) H-Set 1/2/3

Test Number	Propagation Conditions	Reference value		
		HS-PDSCH E_c / I_{or} (dB)	T-put R (kbps) * $\hat{I}_{or} / I_{oc} = 0$ dB	T-put R (kbps) * $\hat{I}_{or} / I_{oc} = 10$ dB
1	PA3	-6	118	399
		-3	225	458
2	PB3	-6	50	199
		-3	173	301
3	VA30	-6	47	204
		-3	172	305
* Notes: 1) The reference value R is for the Fixed Reference Channel (FRC) H-Set 1 2) For Fixed Reference Channel (FRC) H-Set 2 the reference values for R should be scaled (multiplied by 1.5 and rounding to the nearest integer t-put in kbps, where values of $i+1/2$ are rounded up to $i+1$, i integers) 3) For Fixed Reference Channel (FRC) H-Set 3 the reference values for R should be scaled (multiplied by 3 and rounding to the nearest integer t-put in kbps, where values of $i+1/2$ are rounded up to $i+1$, i integer)				

Table 9.2.3A.3: Test Parameters for Testing 16QAM FRCs H-Set 1/H-Set 2/H-Set 3

Parameter	Unit	Test 1	Test 2	Test 3
Phase reference		P-CPICH		
I_{oc}	dBm/3.84 MHz	-60		
DPCH frame offset ($\tau_{DPCH,n}$)	Chip	0		
Redundancy and constellation version coding sequence		{6,2,1,5}		
Maximum number of HARQ transmission		4		
Feedback Error Ratio	%	4		
Closed loop timing adjustment mode		1		
Note: The HS-SCCH-1 and HS-PDSCH shall be transmitted continuously with constant power. HS-SCCH-1 shall only use the identity of the UE under test for those TTI intended for the UE.				

Table 9.2.3A.4 Minimum requirement 16QAM, Fixed Reference Channel (FRC) H-Set 1/2/3

Test Number	Propagation Conditions	Reference value	
		HS-PDSCH E_c / I_{or} (dB)	T-put R (kbps) * $\hat{I}_{or} / I_{oc} = 10$ dB
1	PA3	-6	361
		-3	500
2	PB3	-6	74
		-3	255
3	VA30	-6	84
		-3	254

* Notes: 1)The reference value R is for the Fixed Reference Channel (FRC) H-Set 1
2) For Fixed Reference Channel (FRC) H-Set 2 the reference values for R should be scaled (multiplied by 1.5 and rounding to the nearest integer t-put in kbps, where values of $i+1/2$ are rounded up to $i+1$, i integer)
3) For Fixed Reference Channel (FRC) H-Set 3 the reference values for R should be scaled (multiplied by 3 and rounding to the nearest integer t-put in kbps, where values of $i+1/2$ are rounded up to $i+1$, i integer)

The reference for this requirement is TS 25.101 [1] clauses 9.2.3.1 and 9.2.3.2.

9.2.3A.3 Test purpose

To verify the ability of the receiver to receive a predefined test signal, representing a multi-path fading channel with information bit throughput R not falling below a specified value. The test stresses the multi-code reception and channel decoding with incremental redundancy.

9.2.3A.4 Method of test

9.2.3A.4.1 Initial conditions

Test environment: normal; see clauses G.2.1 and G.2.2.

Frequencies to be tested: mid range; see clause G.2.4.

1. Connect the SS (Node B Emulator) and faders and AWGN noise sources to the UE antenna connector as shown in figure A.12.
2. Set the node B emulator behaviour according to table 9.2.4. Set the test parameters for tests 1-3 according to table 9.2.3A.1 or 9.2.3A.3 and levels according to tables 9.2.3A.6 to 9.2.3A.9. The configuration of the downlink channels is defined in table E.5.3.
3. The information bit data shall be pseudo random and not repeated before 10 different information bit payload blocks are processed. (e.g. Fixed reference Channel Definition H-set 1 (16 QAM): The information bit payload block is 4664 bits long. Hence the PRBS must be at least $4664 * 10$ bits long) Use a PRBS from ITU-T O.153 Ref [27].
4. Setup the fading simulators with fading conditions as described in table D.2.2.1.A and clause D.2.7.

Table 9.2.3A.5: Specific Message Contents for closed loop transmit diversity mode

SYSTEM INFORMATION BLOCK TYPE5

Information Element	Value/remark
PRACH system information list - AICH info - STTD Indicator	TRUE
Secondary CCPCH system information - PICH info - STTD Indicator - Secondary CCPCH info - STTD Indicator	TRUE TRUE
Primary CCPCH info - CHOICE mode - TX Diversity indicator	FDD TRUE

SYSTEM INFORMATION BLOCK TYPE11

Information Element	Value/remark
New intra-frequency cells - Intra-frequency cell id	1
- TX Diversity indicator	TRUE

RRC CONNECTION SETUP

Information Element	Value/remark
CHOICE channel requirement - Number of FBI bit	Uplink DPCH info 1
Downlink information common for all radio links - CHOICE mode - TX Diversity Mode	FDD Closed loop mode1
Downlink DPCH info for each RL - CHOICE mode - Downlink DPCH info for each RL - Closed loop timing adjustment mode	FDD 1

RADIO BEARER SETUP for Closed test loop mode1 and HSDPA

Information Element	Value/remark
CHOICE channel requirement - Number of FBI bit	Uplink DPCH info 1
Downlink information common for all radio links - CHOICE mode - TX Diversity Mode	FDD Closed loop mode1
Downlink DPCH info for each RL - CHOICE mode - Downlink DPCH info for each RL - Closed loop timing adjustment mode	FDD 1

9.2.3A.4.2 Procedure

1. Set up a HSDPA connection with looping back 12.2kbps RMC according to the generic HSDPA set-up procedure specified in TS 34.108 [3] sub clause 7.3.6 with the exceptions for information elements listed in table 9.2.3A.5, with levels according to table E.5.0.
2. Once the HSDPA connection is setup, change levels according to Tables E.5.6 to E.5.8B as specified by table E.5.9 and start transmitting HSDPA Data.
3. For all relevant propagation conditions, for all relevant Ioc levels, for all relevant Ec/Ior, for all relevant $\hat{I}or/Ioc$, for all relevant H-sets in tables 9.2.3A.6 to 9.2.3A.9 count the number of NACK, ACK and statDTX on the UL HS-DPCCH during the test interval and decide pass or fail according to Annex F.6.3 tables F.6.3.5.4.1 and F.6.3.5.4.2. ACK is counted as a pass. NACK and statDTX are counted as a failure.

9.2.3A.5 Test Requirements

Tables 9.2.3A.6 to 9.2.3A.9 define the primary level settings including test tolerance and test parameters for all relevant throughput tests. The pass / fail decision for throughput is done according to Annex F.6.3.

Tables E.5.6 to E.5.8B define the secondary and subsequently ranked level settings including test tolerance. As those level settings are not uniform for the throughput tests in this clause, Table E.5.9 indicates which levels are applied, when the primary level settings (E_c/I_{or} and I_{or}/I_{oc}) and propagation conditions (PA3, PB3, VA30, VA 120) vary.

Note that the levels in tables E.5.6 to E.5.8B, when applied in this subclause (closed loop transmit diversity) are equal to the sum of the levels at both antennas. They are equally divided between both antennas according to Table E.5.3: column Note.

Table 9.2.3A.6: Test Parameters for Testing QPSK FRCs H-Set 1/H-Set 2/H-Set 3

Parameter	Unit	Test 1	Test 2	Test 3
Phase reference		P-CPICH		
I_{oc}	dBm/3.84 MHz	-60 (no test tolerance applied)		

Table 9.2.3A.7: Test requirement QPSK, Fixed Reference Channel (FRC) H-Set 1/2/3

Test Number	Propagation Conditions	Reference value		
		HS-PDSCH E_c/I_{or} (dB)	T-put R (kbps) * $\hat{I}_{or}/I_{oc} = 0.8$ dB	T-put R (kbps) * $\hat{I}_{or}/I_{oc} = 10.8$ dB
1	PA3	-5.9	118	399
		-2.9	225	458
2	PB3	-5.9	50	199
		-2.9	173	301
3	VA30	-5.9	47	204
		-2.9	172	305

* Notes: 1) The reference value R is for the Fixed Reference Channel (FRC) H-Set 1
2) For Fixed Reference Channel (FRC) H-Set 2 the reference values for R should be scaled (multiplied by 1.5 and rounding to the nearest integer t-put in kbps, where values of $i+1/2$ are rounded up to $i+1$, i integers)
3) For Fixed Reference Channel (FRC) H-Set 3 the reference values for R should be scaled (multiplied by 3 and rounding to the nearest integer t-put in kbps, where values of $i+1/2$ are rounded up to $i+1$, i integer)

Table 9.2.3A.8: Test Parameters for Testing 16QAM FRCs H-Set 1/H-Set 2/H-Set 3

Parameter	Unit	Test 1	Test 2	Test 3
Phase reference		P-CPICH		
I_{oc}	dBm/3.84 MHz	-60 (no test tolerance applied)		

Table 9.2.3A.9 Test requirement 16QAM, Fixed Reference Channel (FRC) H-Set 1/2/3

Test Number	Propagation Conditions	Reference value	
		HS-PDSCH E_c / I_{or} (dB)	T-put R (kbps) * $\hat{I}_{or} / I_{oc} = 10.8$ dB
1	PA3	-5.9	361
		-2.9	500
2	PB3	-5.9	74
		-2.9	255
3	VA30	-5.9	84
		-2.9	254

* Notes: 1)The reference value R is for the Fixed Reference Channel (FRC) H-Set 1
2) For Fixed Reference Channel (FRC) H-Set 2 the reference values for R should be scaled (multiplied by 1.5 and rounding to the nearest integer t-put in kbps, where values of $i+1/2$ are rounded up to $i+1$, i integer)
3) For Fixed Reference Channel (FRC) H-Set 3 the reference values for R should be scaled (multiplied by 3 and rounding to the nearest integer t-put in kbps, where values of $i+1/2$ are rounded up to $i+1$, i integer)

NOTE: If the above Test Requirement differs from the Minimum Requirement then the Test Tolerance applied for this test is non-zero. The Test Tolerance for this test is defined in clause F.2 and the explanation of how the Minimum Requirement has been relaxed by the Test Tolerance is given in clause F.4

9.2.3B Closed Loop Diversity Performance - QPSK, Fixed Reference Channel (FRC) H-Set 4/5

9.2.3B.1 Definition and applicability

The receiver closed loop transmit diversity performance of the High Speed Physical Downlink Shared Channel (HS-DSCH) in multi-path fading environments are determined by the information bit throughput R .

The requirements and this test apply to Release 5 and later releases for all types of UTRA for FDD UE that support HSDPA UE capability categories 11 and 12

9.2.3B.2 Minimum requirements

Requirements for a particular UE belonging to certain HS-DSCH category are determined according to the relevant part of Table 9.2.1.

The requirements are specified in terms of minimum information bit throughput R for the DL reference channels H-set 4/5 specified in Annex C.8.1.4 and C.8.1.5 respectively, with the addition of the relevant parameters in Tables 9.2.3B.1 plus the downlink physical channel setup according to table E.5.3.

Using this configuration the throughput shall meet or exceed the minimum requirements specified in tables 9.2.3B.2 and 9.2.3B.3.

Table 9.2.3B.1: Test Parameters for Testing QPSK FRCs H-Set 4/H-Set 5

Parameter	Unit	Test 1	Test 2	Test 3
Phase reference		P-CPICH		
I_{oc}	dBm/3.84 MHz	-60		
DPCH frame offset ($\tau_{DPCH,n}$)	Chip	0		
Redundancy and constellation version coding sequence		{0,2,5,6}		
Maximum number of HARQ transmission		4		
Feedback Error Ratio	%	4		
Closed loop timing adjustment mode		1		
Note: The HS-SCCH-1 and HS-PDSCH shall be transmitted continuously with constant power. HS-SCCH-1 shall only use the identity of the UE under test for those TTI intended for the UE.				

Table 9.2.3B.2: Minimum requirement QPSK, Fixed Reference Channel (FRC) H-Set 4

Test Number	Propagation Conditions	Reference value		
		HS-PDSCH E_c / I_{or} (dB)	T-put R (kbps) * $\hat{I}_{or} / I_{oc} = 0$ dB	T-put R (kbps) * $\hat{I}_{or} / I_{oc} = 10$ dB
1	PA3	-6	114	398
		-3	223	457
2	PB3	-6	43	196
		-3	167	292
3	VA30	-6	40	199
		-3	170	305
* Note: The reference value R is for the Fixed Reference Channel (FRC) H-Set 4				

Table 9.2.3B.3: Minimum requirement QPSK, Fixed Reference Channel (FRC) H-Set 5

Test Number	Propagation Conditions	Reference value		
		HS-PDSCH E_c / I_{or} (dB)	T-put R (kbps) * $\hat{I}_{or} / I_{oc} = 0$ dB	T-put R (kbps) * $\hat{I}_{or} / I_{oc} = 10$ dB
1	PA3	-6	177	599
		-3	338	687
2	PB3	-6	75	299
		-3	260	452
3	VA30	-6	71	306
		-3	258	458
* Note: The reference value R is for the Fixed Reference Channel (FRC) H-Set 5				

The reference for this requirement is TS 25.101 [1] clause 9.2.3.3.

9.2.3B.3 Test purpose

To verify the ability of the receiver to receive a predefined test signal, representing a multi-path fading channel with information bit throughput R not falling below a specified value. The test stresses the multi-code reception and channel decoding with incremental redundancy.

9.2.3B.4 Method of test

9.2.3B.4.1 Initial conditions

Test environment: normal; see clauses G.2.1 and G.2.2.

Frequencies to be tested: mid range; see clause G.2.4.

1. Connect the SS (Node B Emulator) and faders and AWGN noise sources to the UE antenna connector as shown in figure A.12.
2. Set the node B emulator behaviour according to table 9.2.4. Set the test parameters for tests 1-3 according to table 9.2.3B.1 and levels according to tables 9.2.3B.5 to 9.2.3B.7. The configuration of the downlink channels is defined in table E.5.3.
3. The information bit data shall be pseudo random and not repeated before 10 different information bit payload blocks are processed. (e.g. Fixed reference Channel Definition H-set 1 (16 QAM): The information bit payload block is 4664 bits long. Hence the PRBS must be at least $4664 * 10$ bits long) Use a PRBS from ITU-T O.153 Ref [27].
4. Setup the fading simulators with fading conditions as described in table D.2.2.1.A and clause D.2.7.

Table 9.2.3B.4: Specific Message Contents for closed loop transmit diversity mode

SYSTEM INFORMATION BLOCK TYPE5

Information Element	Value/remark
PRACH system information list - AICH info - STTD Indicator	TRUE
Secondary CCPCH system information - PICH info - STTD Indicator - Secondary CCPCH info - STTD Indicator	TRUE TRUE
Primary CCPCH info - CHOICE mode - TX Diversity indicator	FDD TRUE

SYSTEM INFORMATION BLOCK TYPE11

Information Element	Value/remark
New intra-frequency cells - Intra-frequency cell id	1
- TX Diversity indicator	TRUE

RRC CONNECTION SETUP

Information Element	Value/remark
CHOICE channel requirement - Number of FBI bit	Uplink DPCH info 1
Downlink information common for all radio links - CHOICE mode - TX Diversity Mode	FDD Closed loop mode1
Downlink DPCH info for each RL - CHOICE mode - Downlink DPCH info for each RL - Closed loop timing adjustment mode	FDD 1

RADIO BEARER SETUP for Closed test loop mode1 and HSDPA

Information Element	Value/remark
CHOICE channel requirement - Number of FBI bit	Uplink DPCH info 1
Downlink information common for all radio links - CHOICE mode - TX Diversity Mode	FDD Closed loop mode1
Downlink DPCH info for each RL - CHOICE mode - Downlink DPCH info for each RL - Closed loop timing adjustment mode	FDD 1

9.2.3B.4.2 Procedure

1. Set up a HSDPA connection with looping back 12.2kbps RMC according to the generic HSDPA set-up procedure specified in TS 34.108 [3] sub clause 7.3.6 with the exceptions for information elements listed in table 9.2.3B.4, with levels according to table E.5.0.
2. Once the HSDPA connection is setup, change levels according to Tables E.5.6 to E.5.8B as specified by table E.5.9 and start transmitting HSDPA Data.
3. For all relevant propagation conditions, for all relevant I_{oc} levels, for all relevant E_c/I_{or} , for all relevant \hat{I}_{or}/I_{oc} , for all relevant H-sets in tables 9.2.3B.5 to 9.2.3B.7 count the number of NACK, ACK and statDTX on the UL HS-DPCCH during the test interval and decide pass or fail according to Annex F.6.3 tables F.6.3.5.4.3 and F.6.3.5.4.4. ACK is counted as a pass. NACK and statDTX are counted as a failure.

9.2.3B.5 Test Requirements

Tables 9.2.3B.5 to 9.2.3B.7 define the primary level settings including test tolerance and test parameters for all relevant throughput tests. The pass / fail decision for throughput is done according to Annex F.6.3.

Tables E.5.6 to E.5.8B define the secondary and subsequently ranked level settings including test tolerance. As those level settings are not uniform for the throughput tests in this clause, Table E.5.9 indicates which levels are applied, when the primary level settings (E_c/I_{or} and I_{or}/I_{oc}) and propagation conditions (PA3, PB3, VA30, VA 120) vary.

Note that the levels in tables E.5.6 to E.5.8B, when applied in this subclause (closed loop transmit diversity) are equal to the sum of the levels at both antennas. They are equally divided between both antennas according to Table E.5.3: column Note.

Table 9.2.3B.5: Test Parameters for Testing QPSK FRCs H-Set 4/H-Set 5

Parameter	Unit	Test 1	Test 2	Test 3
Phase reference		P-CPICH		
I_{oc}	dBm/3.84 MHz	-60 (no test tolerance applied)		

Table 9.2.3B.6: Test requirement QPSK, Fixed Reference Channel (FRC) H-Set 4

Test Number	Propagation Conditions	Reference value		
		HS-PDSCH E_c/I_{or} (dB)	T-put R (kbps) * $\hat{I}_{or}/I_{oc} = 0.8$ dB	T-put R (kbps) * $\hat{I}_{or}/I_{oc} = 10.8$ dB
1	PA3	-5.9	114	398
		-2.9	223	457
2	PB3	-5.9	43	196
		-2.9	167	292
3	VA30	-5.9	40	199
		-2.9	170	305

* Note: The reference value R is for the Fixed Reference Channel (FRC) H-Set 4

Table 9.2.3B.7: Test requirement QPSK, Fixed Reference Channel (FRC) H-Set 5

Test Number	Propagation Conditions	Reference value		
		HS-PDSCH E_c/I_{or} (dB)	T-put R (kbps) * $\hat{I}_{or}/I_{oc} = 0.8$ dB	T-put R (kbps) * $\hat{I}_{or}/I_{oc} = 10.8$ dB
1	PA3	-5.9	177	599
		-2.9	338	687
2	PB3	-5.9	75	299
		-2.9	260	452
3	VA30	-5.9	71	306
		-2.9	258	458

* Note: The reference value R is for the Fixed Reference Channel (FRC) H-Set 5

NOTE: If the above Test Requirement differs from the Minimum Requirement then the Test Tolerance applied for this test is non-zero. The Test Tolerance for this test is defined in clause F.2 and the explanation of how the Minimum Requirement has been relaxed by the Test Tolerance is given in clause F.4

9.2.3C Closed Loop Diversity Performance Enhanced Performance Requirements Type 1, QPSK/16QAM, Fixed Reference Channel (FRC) H-Set 1/2/3

9.2.3C.1 Definition and applicability

The receiver closed loop transmit diversity performance of the High Speed Physical Downlink Shared Channel (HS-DSCH) in multi-path fading environments are determined by the information bit throughput R. The requirements and this test apply to Release 6 and later releases for all types of UTRA for FDD UE that support HSDPA UE capability categories 1 to 8 and the optional enhanced performance requirements type 1.

9.2.3C.2 Minimum requirements

Requirements for a particular UE belonging to certain HS-DSCH category are determined according to the relevant part of Table 9.2.2.

The requirements are specified in terms of minimum information bit throughput R for the DL reference channels H-set 1/2/3 specified in Annex C.8.1.1, C.8.1.2 and C.8.1.3 respectively, with the addition of the relevant parameters in Tables 9.2.3C.1 and 9.2.3C.3 plus the downlink physical channel setup according to table E.5.3.

Using this configuration the throughput shall meet or exceed the minimum requirements specified in tables 9.2.3C.2 and 9.2.3C.4.

Table 9.2.3C.1: Test Parameters for Testing QPSK FRCs H-Set 1/H-Set 2/H-Set 3

Parameter	Unit	Test 1	Test 2	Test 3
Phase reference		P-CPICH		
I_{oc}	dBm/3.84 MHz		-60	
DPCH frame offset ($\tau_{DPCH,n}$)	Chip		0	
Redundancy and constellation version coding sequence			{0,2,5,6}	
Maximum number of HARQ transmission			4	
Feedback Error Ratio	%		4	
Closed loop timing adjustment mode			1	
Note:	The HS-SCCH-1 and HS-PDSCH shall be transmitted continuously with constant power. HS-SCCH-1 shall only use the identity of the UE under test for those TTI intended for the UE.			

Table 9.2.3C.2: Minimum requirement Enhanced requirement type 1, QPSK, Fixed Reference Channel (FRC) H-Set 1/2/3

Test Number	Propagation Conditions	Reference value		
		HS-PDSCH E_c / I_{or} (dB)	T-put R (kbps) * $\hat{I}_{or} / I_{oc} = 0$ dB	T-put R (kbps) * $\hat{I}_{or} / I_{oc} = 10$ dB
1	PA3	-6	118	399
		-3	225	458
2	PB3	-6	50	199
		-3	173	301
3	VA30	-6	47	204
		-3	172	305

* Notes: 1) The reference value R is for the Fixed Reference Channel (FRC) H-Set 1
2) For Fixed Reference Channel (FRC) H-Set 2 the reference values for R should be scaled (multiplied by 1.5 and rounding to the nearest integer t-put in kbps, where values of $i+1/2$ are rounded up to $i+1$, i integers)
3) For Fixed Reference Channel (FRC) H-Set 3 the reference values for R should be scaled (multiplied by 3 and rounding to the nearest integer t-put in kbps, where values of $i+1/2$ are rounded up to $i+1$, i integer)

Table 9.2.3C.3: Test Parameters for Testing 16QAM FRCs H-Set 1/H-Set 2/H-Set 3

Parameter	Unit	Test 1	Test 2	Test 3
Phase reference		P-CPICH		
I_{oc}	dBm/3.84 MHz	-60		
DPCH frame offset ($\tau_{DPCH,n}$)	Chip	0		
Redundancy and constellation version coding sequence		{6,2,1,5}		
Maximum number of HARQ transmission		4		
Feedback Error Ratio	%	4		
Closed loop timing adjustment mode		1		

Note: The HS-SCCH-1 and HS-PDSCH shall be transmitted continuously with constant power. HS-SCCH-1 shall only use the identity of the UE under test for those TTI intended for the UE.

Table 9.2.3C.4 Minimum requirement Enhanced requirement type 1, 16QAM, Fixed Reference Channel (FRC) H-Set 1/2/3

Test Number	Propagation Conditions	Reference value	
		HS-PDSCH E_c / I_{or} (dB)	T-put R (kbps) * $\hat{I}_{or} / I_{oc} = 10$ dB
1	PA3	-6	361
		-3	500
2	PB3	-6	74
		-3	255
3	VA30	-6	84
		-3	254

* Notes: 1) The reference value R is for the Fixed Reference Channel (FRC) H-Set 1
2) For Fixed Reference Channel (FRC) H-Set 2 the reference values for R should be scaled (multiplied by 1.5 and rounding to the nearest integer t-put in kbps, where values of $i+1/2$ are rounded up to $i+1$, i integer)
3) For Fixed Reference Channel (FRC) H-Set 3 the reference values for R should be scaled (multiplied by 3 and rounding to the nearest integer t-put in kbps, where values of $i+1/2$ are rounded up to $i+1$, i integer)

The reference for this requirement is TS 25.101 [1] clauses 9.2.3.1 and 9.2.3.2.

9.2.3C.3 Test purpose

To verify the ability of the receiver to receive a predefined test signal, representing a multi-path fading channel with information bit throughput R not falling below a specified value. The test stresses the multi-code reception and channel decoding with incremental redundancy.

9.2.3C.4 Method of test

9.2.3C.4.1 Initial conditions

Test environment: normal; see clauses G.2.1 and G.2.2.

Frequencies to be tested: mid range; see clause G.2.4.

1. Connect the SS (Node B Emulator) and faders and AWGN noise sources to the UE antenna connector as shown in figure A.22 for UEs that support receive diversity or figure A.12 for UEs that do not support receive diversity.
2. Set the node B emulator behaviour according to table 9.2.4. Set the test parameters for tests 1-3 according to table 9.2.3C.1 or 9.2.3C.3 and levels according to tables 9.2.3C.6 to 9.2.3C.9. The configuration of the downlink channels is defined in table E.5.3.
3. The information bit data shall be pseudo random and not repeated before 10 different information bit payload blocks are processed. (e.g. Fixed reference Channel Definition H-set 1 (16 QAM): The information bit payload block is 4664 bits long. Hence the PRBS must be at least $4664 * 10$ bits long) Use a PRBS from ITU-T O.153 Ref [27].
4. Setup the fading simulators with fading conditions as described in table D.2.2.1.A and clause D.2.5.

Table 9.2.3C.5: Specific Message Contents for closed loop transmit diversity mode

SYSTEM INFORMATION BLOCK TYPE5

Information Element	Value/remark
PRACH system information list - AICH info - STTD Indicator	TRUE
Secondary CCPCH system information - PICH info - STTD Indicator - Secondary CCPCH info - STTD Indicator	TRUE TRUE
Primary CCPCH info - CHOICE mode - TX Diversity indicator	FDD TRUE

SYSTEM INFORMATION BLOCK TYPE11

Information Element	Value/remark
New intra-frequency cells - Intra-frequency cell id	1
- TX Diversity indicator	TRUE

RRC CONNECTION SETUP

Information Element	Value/remark
CHOICE channel requirement - Number of FBI bit	Uplink DPCH info 1
Downlink information common for all radio links - CHOICE mode - TX Diversity Mode	FDD Closed loop mode1
Downlink DPCH info for each RL - CHOICE mode - Downlink DPCH info for each RL - Closed loop timing adjustment mode	FDD 1

RADIO BEARER SETUP for Closed test loop mode1 and HSDPA

Information Element	Value/remark
CHOICE channel requirement - Number of FBI bit	Uplink DPCH info 1
Downlink information common for all radio links - CHOICE mode - TX Diversity Mode	FDD Closed loop mode1
Downlink DPCH info for each RL - CHOICE mode - Downlink DPCH info for each RL - Closed loop timing adjustment mode	FDD 1

9.2.3C.4.2 Procedure

1. Set up a HSDPA connection with looping back 12.2kbps RMC according to the generic HSDPA set-up procedure specified in TS 34.108 [3] sub clause 7.3.6 with the exceptions for information elements listed in table 9.2.3C.5, with levels according to table E.5.0.
2. Once the HSDPA connection is setup, change levels according to Tables E.5.6 to E.5.8B as specified by table E.5.9 and start transmitting HSDPA Data.
3. For all relevant propagation conditions, for all relevant I_{oc} levels, for all relevant E_c/I_{or} , for all relevant \hat{I}_{or}/I_{oc} , for all relevant H-sets in tables 9.2.3C.6 to 9.2.3C.9 count the number of NACK, ACK and statDTX on the UL HS-DPCCH during the test interval and decide pass or fail according to Annex F.6.3 tables F.6.3.5.4.1 and F.6.3.5.4.2. ACK is counted as a pass. NACK and statDTX are counted as a failure.

9.2.3C.5 Test Requirements

Tables 9.2.3C.6 to 9.2.3C.9 define the primary level settings including test tolerance and test parameters for all relevant throughput tests. The pass / fail decision for throughput is done according to Annex F.6.3.

Tables E.5.6 to E.5.8B define the secondary and subsequently ranked level settings including test tolerance. As those level settings are not uniform for the throughput tests in this clause, Table E.5.9 indicates which levels are applied, when the primary level settings (E_c/I_{or} and I_{or}/I_{oc}) and propagation conditions (PA3, PB3, VA30, VA 120) vary.

Note that the levels in tables E.5.6 to E.5.8B, when applied in this subclause (closed loop transmit diversity) are equal to the sum of the levels at both antennas. They are equally divided between both antennas according to Table E.5.3: column Note.

Table 9.2.3C.6: Test Parameters for Testing QPSK FRCs H-Set 1/H-Set 2/H-Set 3

Parameter	Unit	Test 1	Test 2	Test 3
Phase reference			P-CPICH	
I_{oc}	dBm/3.84 MHz	-60 (no test tolerance applied)		

Table 9.2.3C.7: Test requirement Enhanced requirement type 1, QPSK, Fixed Reference Channel (FRC) H-Set 1/2/3

Test Number	Propagation Conditions	Reference value		
		HS-PDSCH E_c / I_{or} (dB)	T-put R (kbps) * $\hat{I}_{or} / I_{oc} = 0.8$ dB	T-put R (kbps) * $\hat{I}_{or} / I_{oc} = 10.8$ dB
1	PA3	-5.9	118	399
		-2.9	225	458
2	PB3	-5.9	50	199
		-2.9	173	301
3	VA30	-5.9	47	204
		-2.9	172	305

* Notes: 1) The reference value R is for the Fixed Reference Channel (FRC) H-Set 1
2) For Fixed Reference Channel (FRC) H-Set 2 the reference values for R should be scaled (multiplied by 1.5 and rounding to the nearest integer t-put in kbps, where values of $i+1/2$ are rounded up to $i+1$, i integers)
3) For Fixed Reference Channel (FRC) H-Set 3 the reference values for R should be scaled (multiplied by 3 and rounding to the nearest integer t-put in kbps, where values of $i+1/2$ are rounded up to $i+1$, i integer)

Table 9.2.3C.8: Test Parameters for Testing 16QAM FRCs H-Set 1/H-Set 2/H-Set 3

Parameter	Unit	Test 1	Test 2	Test 3
Phase reference		P-CPICH		
I_{oc}	dBm/3.84 MHz	-60 (no test tolerance applied)		

Table 9.2.3C.9 Test requirement Enhanced requirement type 1, 16QAM, Fixed Reference Channel (FRC) H-Set 1/2/3

Test Number	Propagation Conditions	Reference value	
		HS-PDSCH E_c / I_{or} (dB)	T-put R (kbps) * $\hat{I}_{or} / I_{oc} = 10.8$ dB
1	PA3	-5.9	361
		-2.9	500
2	PB3	-5.9	74
		-2.9	255
3	VA30	-5.9	84
		-2.9	254

* Notes: 1)The reference value R is for the Fixed Reference Channel (FRC) H-Set 1
2) For Fixed Reference Channel (FRC) H-Set 2 the reference values for R should be scaled (multiplied by 1.5 and rounding to the nearest integer t-put in kbps, where values of $i+1/2$ are rounded up to $i+1$, i integer)
3) For Fixed Reference Channel (FRC) H-Set 3 the reference values for R should be scaled (multiplied by 3 and rounding to the nearest integer t-put in kbps, where values of $i+1/2$ are rounded up to $i+1$, i integer)

NOTE: If the above Test Requirement differs from the Minimum Requirement then the Test Tolerance applied for this test is non-zero. The Test Tolerance for this test is defined in clause F.2 and the explanation of how the Minimum Requirement has been relaxed by the Test Tolerance is given in clause F.4

9.2.3D Closed Loop Diversity Performance - Enhanced Performance Requirements Type 2 - QPSK/16QAM, Fixed Reference Channel (FRC) H-Set 6/3

9.2.3D.1 Definition and applicability

The receiver closed loop transmit diversity performance of the High Speed Physical Downlink Shared Channel (HS-DSCH) in multi-path fading environments are determined by the information bit throughput R .

The requirements and this test apply for Release 6 and later releases to all types of UTRA for the FDD UE that support HSDPA UE capability categories 7 and 8 and the optional enhanced performance requirements type 2.

9.2.3D.2 Minimum requirements

Requirements for a particular UE belonging to certain HS-DSCH category are determined according to the relevant part of Table 9.2.3.

The requirements are specified in terms of minimum information bit throughput R for the DL reference channels H-set 6/3 specified in Annex C.8.1.6 and C.8.1.3 respectively, with the addition of the relevant parameters in Tables 9.2.3D.1, 9.2.3D.3, 9.2.3D.5 and 9.2.3D.7 plus the downlink physical channel setup according to table E.5.3.

Using this configuration the throughput shall meet or exceed the minimum requirements specified in tables 9.2.3D.2, 9.2.3D.4, 9.2.3D.6 and 9.2.3D.8.

Table 9.2.3D.1: Test Parameters for Testing QPSK FRCs H-Set 6

Parameter	Unit	Test 1
Phase reference		P-CPICH
I_{oc}	dBm/3.84 MHz	-60
DPCH frame offset ($\tau_{DPCH,n}$)	Chip	0
Redundancy and constellation version coding sequence		{0,2,5,6}
Maximum number of HARQ transmission		4
Feedback Error Rate	%	4
Closed loop timing adjustment mode		1
Note:	The HS-SCCH-1 and HS-PDSCH shall be transmitted continuously with constant power. HS-SCCH-1 shall only use the identity of the UE under test for those TTI intended for the UE.	

Table 9.2.3D.2: Minimum requirement Enhanced requirement type 2 QPSK, Fixed Reference Channel (FRC) H-Set 6

Test Number	Propagation Conditions	Reference value	
		HS-PDSCH E_c / I_{or} (dB)	T-put R (kbps) * $\hat{I}_{or} / I_{oc} = 10$ dB
1	PB3	-3	1536

Table 9.2.3D.3: Test Parameters for Testing 16-QAM FRCs H-Set 6

Parameter	Unit	Test 1
Phase reference		P-CPICH
I_{oc}	dBm/3.84 MHz	-60
DPCH frame offset ($\tau_{DPCH,n}$)	Chip	0
Redundancy and constellation version coding sequence		{6,2,1,5}
Maximum number of HARQ transmission		4
Feedback Error Rate	%	4
Closed loop timing adjustment mode		1
Note:	The HS-SCCH-1 and HS-PDSCH shall be transmitted continuously with constant power. HS-SCCH-1 shall only use the identity of the UE under test for those TTI intended for the UE.	

Table 9.2.3D.4: Minimum requirement Enhanced requirement type 2 16QAM, Fixed Reference Channel (FRC) H-Set 6

Test Number	Propagation Conditions	Reference value	
		HS-PDSCH E_c / I_{or} (dB)	T-put R (kbps) * $\hat{I}_{or} / I_{oc} = 10$ dB
1	PB3	-3	1154

Table 9.2.3D.5: Test Parameters for Testing QPSK FRCs H-Set 3

Parameter	Unit	Test 1	Test 2	Test 3
Phase reference			P-CPICH	
I_{oc}	dBm/3.84 MHz		-60	
DPCH frame offset ($\tau_{DPCH,n}$)	Chip		0	
Redundancy and constellation version coding sequence			{0,2,5,6}	
Maximum number of HARQ transmission			4	
Feedback Error Ratio	%		4	
Closed loop timing adjustment mode			1	
Note:	The HS-SCCH-1 and HS-PDSCH shall be transmitted continuously with constant power. HS-SCCH-1 shall only use the identity of the UE under test for those TTI intended for the UE.			

Table 9.2.3D.6: Minimum requirement Enhanced performance requirements Type 2, QPSK, Fixed Reference Channel (FRC) H-Set 3

Test Number	Propagation Conditions	Reference value		
		HS-PDSCH E_c / I_{or} (dB)	T-put R (kbps) * $\hat{I}_{or} / I_{oc} = 0$ dB	T-put R (kbps) * $\hat{I}_{or} / I_{oc} = 10$ dB
1	PA3	-6	118	399
		-3	225	458
2	PB3	-6	50	199
		-3	173	*Note 2
3	VA30	-6	47	204
		-3	172	305
<p>* Notes: 1) The reference value R is for the Fixed Reference Channel (FRC) H-Set 1, for Fixed Reference Channel (FRC) H-Set 3 the reference values for R should be scaled (multiplied by 3 and rounding to the nearest integer t-put in kbps, where values of $i+1/2$ are rounded up to $i+1$, i integer)</p> <p>2) Closed loop transmit diversity enhanced performance requirements type 2 for Categories 7 and 8 in Pedestrian B 3km/h with $\hat{I}_{or} / I_{oc} = 10$ dB and $E_c / I_{or} = -3$ dB are set according to H-Set 6.</p>				

Table 9.2.3D.7: Test Parameters for Testing 16QAM FRCs H-Set 3

Parameter	Unit	Test 1	Test 2	Test 3
Phase reference		P-CPICH		
I_{oc}	dBm/3.84 MHz	-60		
DPCH frame offset ($\tau_{DPCH,n}$)	Chip	0		
Redundancy and constellation version coding sequence		{6,2,1,5}		
Maximum number of HARQ transmission		4		
Feedback Error Ratio	%	4		
Closed loop timing adjustment mode		1		
Note: The HS-SCCH-1 and HS-PDSCH shall be transmitted continuously with constant power. HS-SCCH-1 shall only use the identity of the UE under test for those TTI intended for the UE.				

Table 9.2.3D.8 Minimum requirement Enhanced performance requirements Type 2, 16QAM, Fixed Reference Channel (FRC) H-Set 3

Test Number	Propagation Conditions	Reference value	
		HS-PDSCH E_c / I_{or} (dB)	T-put R (kbps) * $\hat{I}_{or} / I_{oc} = 10$ dB
1	PA3	-6	361
		-3	500
2	PB3	-6	74
		-3	*Note 2
3	VA30	-6	84
		-3	254
* Notes: 1) The reference value R is for the Fixed Reference Channel (FRC) H-Set 1, for Fixed Reference Channel (FRC) H-Set 3 the reference values for R should be scaled (multiplied by 3 and rounding to the nearest integer t-put in kbps, where values of $i+1/2$ are rounded up to $i+1$, i integer) 2) Closed loop transmit diversity enhanced performance requirements type 2 for Categories 7 and 8 in Pedestrian B 3km/h with $\hat{I}_{or} / I_{oc} = 10$ dB and $E_c / I_{or} = -3$ dB are set according to H-Set 6.			

The reference for this requirement is TS 25.101 [1] clauses 9.2.3.1, 9.2.3.2, 9.2.3.4 and 9.2.3.5.

9.2.3D.3 Test purpose

To verify the ability of the receiver to receive a predefined test signal, representing a multi-path fading channel with information bit throughput R not falling below a specified value. The test stresses the multi-code reception and channel decoding with incremental redundancy.

9.2.3D.4 Method of test

9.2.3D.4.1 Initial conditions

Test environment: normal; see clauses G.2.1 and G.2.2.

Frequencies to be tested: mid range; see clause G.2.4.

1. Connect the SS (Node B Emulator) and faders and AWGN noise sources to the UE antenna connector as shown in figure A.12.

2. Set the node B emulator behaviour according to table 9.2.4. Set the test parameters for tests 1-3 according to table 9.2.3D.1, 9.2.3D.3, 9.2.3D.5 or 9.2.3D.7 and levels according to tables 9.2.3D.10 to 9.2.3D.17. The configuration of the downlink channels is defined in table E.5.3.
3. The information bit data shall be pseudo random and not repeated before 10 different information bit payload blocks are processed. (e.g. Fixed reference Channel Definition H-set 1 (16 QAM): The information bit payload block is 4664 bits long. Hence the PRBS must be at least 4664 * 10 bits long) Use a PRBS from ITU-T O.153 Ref [27].
4. Setup the fading simulators with fading conditions as described in table D.2.2.1.A and clause D.2.7.

Table 9.2.3D.9: Specific Message Contents for closed loop transmit diversity mode

SYSTEM INFORMATION BLOCK TYPE5

Information Element	Value/remark
PRACH system information list - AICH info - STTD Indicator	TRUE
Secondary CCPCH system information - PICH info - STTD Indicator - Secondary CCPCH info - STTD Indicator	TRUE TRUE
Primary CCPCH info - CHOICE mode - TX Diversity indicator	FDD TRUE

SYSTEM INFORMATION BLOCK TYPE11

Information Element	Value/remark
New intra-frequency cells - Intra-frequency cell id	1
- TX Diversity indicator	TRUE

RRC CONNECTION SETUP

Information Element	Value/remark
CHOICE channel requirement - Number of FBI bit	Uplink DPCH info 1
Downlink information common for all radio links - CHOICE mode - TX Diversity Mode	FDD Closed loop mode1
Downlink DPCH info for each RL - CHOICE mode - Downlink DPCH info for each RL - Closed loop timing adjustment mode	FDD 1

RADIO BEARER SETUP for Closed test loop mode1 and HSDPA

Information Element	Value/remark
CHOICE channel requirement - Number of FBI bit	Uplink DPCH info 1
Downlink information common for all radio links - CHOICE mode - TX Diversity Mode	FDD Closed loop mode1
Downlink DPCH info for each RL - CHOICE mode - Downlink DPCH info for each RL - Closed loop timing adjustment mode	FDD 1

9.2.3D.4.2 Procedure

1. Set up a HSDPA connection with looping back 12.2kbps RMC according to the generic HSDPA set-up procedure specified in TS 34.108 [3] sub clause 7.3.6 with the exceptions for information elements listed in table 9.2.3D.9, with levels according to table E.5.0.
2. Once the HSDPA connection is setup, change levels according to Tables E.5.6 to E.5.8B as specified by table E.5.9 and start transmitting HSDPA Data.
3. For all relevant propagation conditions, for all relevant I_{oc} levels, for all relevant E_c/I_{or} , for all relevant \hat{I}_{or}/I_{oc} , for all relevant H-sets in tables 9.2.3D.10 to 9.2.3D.17 count the number of NACK, ACK and statDTX on the UL HS-DPCCH during the test interval and decide pass or fail according to Annex F.6.3 tables F.6.3.5.4.1, F.6.3.5.4.2, F.6.3.5.4.5 and F.6.3.5.4.6. ACK is counted as a pass. NACK and statDTX are counted as a failure.

9.2.3D.5 Test Requirements

Tables 9.2.3D.10 to 9.2.3D.17 define the primary level settings including test tolerance and test parameters for all relevant throughput tests. The pass / fail decision for throughput is done according to Annex F.6.3.

Tables E.5.6 to E.5.8B define the secondary and subsequently ranked level settings including test tolerance. As those level settings are not uniform for the throughput tests in this clause, Table E.5.9 indicates which levels are applied, when the primary level settings (E_c/I_{or} and I_{or}/I_{oc}) and propagation conditions (PA3, PB3, VA30, VA 120) vary.

Note that the levels in tables E.5.6 to E.5.8B, when applied in this subclause (closed loop transmit diversity) are equal to the sum of the levels at both antennas. They are equally divided between both antennas according to Table E.5.3: column Note.

Table 9.2.3D.10: Test Parameters for Testing QPSK FRCs H-Set 6

Parameter	Unit	Test 1
Phase reference		P-CPICH
I_{oc}	dBm/3.84 MHz	-60 (no test tolerance applied)

Table 9.2.3D.11: Test requirement Enhanced requirement type 2 QPSK, Fixed Reference Channel (FRC) H-Set 6

Test Number	Propagation Conditions	Reference value	
		HS-PDSCH E_c/I_{or} (dB)	T-put R (kbps) * $\hat{I}_{or}/I_{oc} = 10.8$ dB
1	PB3	-2.9	1536

Table 9.2.3D.12: Test Parameters for Testing 16-QAM FRCs H-Set 6

Parameter	Unit	Test 1
Phase reference		P-CPICH
I_{oc}	dBm/3.84 MHz	-60 (no test tolerance applied)

Table 9.2.3D.13: Test requirement Enhanced requirement type 2 16QAM, Fixed Reference Channel (FRC) H-Set 6

Test Number	Propagation Conditions	Reference value	
		HS-PDSCH E_c/I_{or} (dB)	T-put R (kbps) * $\hat{I}_{or}/I_{oc} = 10.8$ dB
1	PB3	-2.9	1154

Table 9.2.3D.14: Test Parameters for Testing QPSK FRCs H-Set 3

Parameter	Unit	Test 1	Test 2	Test 3
Phase reference		P-CPICH		
I_{oc}	dBm/3.84 MHz	-60 (no test tolerance applied)		

Table 9.2.3D.15: Test requirement Enhanced performance requirements Type 2, QPSK, Fixed Reference Channel (FRC) H-Set 3

Test Number	Propagation Conditions	Reference value		
		HS-PDSCH E_c / I_{or} (dB)	T-put R (kbps) * $\hat{I}_{or} / I_{oc} = 0.8$ dB	T-put R (kbps) * $\hat{I}_{or} / I_{oc} = 10.8$ dB
1	PA3	-5.9	118	399
		-2.9	225	458
2	PB3	-5.9	50	199
		-2.9	173	*Note 2
3	VA30	-5.9	47	204
		-2.9	172	305

* Notes: 1) The reference value R is for the Fixed Reference Channel (FRC) H-Set 1, for Fixed Reference Channel (FRC) H-Set 3 the reference values for R should be scaled (multiplied by 3 and rounding to the nearest integer t-put in kbps, where values of $i+1/2$ are rounded up to $i+1$, i integer)
2) Closed loop transmit diversity enhanced performance requirements type 2 for Categories 7 and 8 in Pedestrian B 3km/h with $\hat{I}_{or} / I_{oc} = 10$ dB and $E_c / I_{or} = -3$ dB are set according to H-Set 6.

Table 9.2.3D.16: Test Parameters for Testing 16QAM FRCs H-Set 3

Parameter	Unit	Test 1	Test 2	Test 3
Phase reference		P-CPICH		
I_{oc}	dBm/3.84 MHz	-60 (no test tolerance applied)		

Table 9.2.3D.17 Test requirement Enhanced performance requirements Type 2, 16QAM, Fixed Reference Channel (FRC) H-Set 3

Test Number	Propagation Conditions	Reference value	
		HS-PDSCH E_c / I_{or} (dB)	T-put R (kbps) * $\hat{I}_{or} / I_{oc} = 10.8$ dB
1	PA3	-5.9	361
		-2.9	500
2	PB3	-5.9	74
		-2.9	*Note 2
3	VA30	-5.9	84
		-2.9	254

* Notes: 1) The reference value R is for the Fixed Reference Channel (FRC) H-Set 1, for Fixed Reference Channel (FRC) H-Set 3 the reference values for R should be scaled (multiplied by 3 and rounding to the nearest integer t-put in kbps, where values of $i+1/2$ are rounded up to $i+1$, i integer)
2) Closed loop transmit diversity enhanced performance requirements type 2 for Categories 7 and 8 in Pedestrian B 3km/h with $\hat{I}_{or} / I_{oc} = 10$ dB and $E_c / I_{or} = -3$ dB are set according to H-Set 6.

NOTE: If the above Test Requirement differs from the Minimum Requirement then the Test Tolerance applied for this test is non-zero. The Test Tolerance for this test is defined in clause F.2 and the explanation of how the Minimum Requirement has been relaxed by the Test Tolerance is given in clause F.4

9.3 Reporting of Channel Quality Indicator

For the cases in this subclause where CQI reporting is evaluated under fading conditions it is expected that the UE will not always detect the HS-SCCH, resulting in a DTX for the uplink ACK/NACK transmission. The downlink configuration for evaluating CQI performance does not use retransmission. Therefore any BLER calculations must exclude any packets where the UE may have attempted to combine data from more than one transmission due to having missed one or more new data indicators from lost HS-SCCH transmissions.

The implication of this situation is covered in the procedure for each test.

9.3.1 Single Link Performance - AWGN Propagation Conditions

9.3.1.1 Definition and applicability

The reporting accuracy of channel quality indicator (CQI) under AWGN environments is determined by the reporting variance and the BLER performance using the transport format indicated by the reported CQI median.

The requirements and this test apply to all types of UTRA for the FDD UE that support HSDPA.

9.3.1.2 Minimum requirements

For the parameters specified in Table 9.3.1.1, and using the downlink physical channels specified in table E.5.1 the reported CQI value shall be in the range of ± 2 of the reported median more than 90% of the time. If the HS-PDSCH BLER using the transport format indicated by median CQI is less than or equal to 0.1, the BLER using the transport format indicated by the (median CQI +2) shall be greater than 0.1. If the HS-PDSCH BLER using the transport format indicated by the median CQI is greater than 0.1, the BLER using transport format indicated by (median CQI -1) shall be less than or equal to 0.1.

Table 9.3.1.1: Test Parameters for CQI test in AWGN – single link

Parameter	Unit	Test 1	Test 2	Test 3
\hat{I}_{or} / I_{oc}	dB	0	5	10
I_{oc}	dBm/3.84 MHz	-60		
Phase reference	-	P-CPICH		
HS-PDSCH E_c / I_{or}	dB	-3		
HS-SCCH_1 E_c / I_{or}	dB	-10		
DPCH E_c / I_{or}	dB	-10		
Maximum number of H-ARQ transmission	-	1		
Number of HS-SCCH set to be monitored	-	1		
CQI feedback cycle	ms	2		
CQI repetition factor	-	1		
HS-SCCH-1 signalling pattern	-	To incorporate inter-TTI=3 the six sub-frame HS-SCCH-1 signalling pattern shall be "...XOOXOO...", where "X" indicates TTI in which the HS-SCCH-1 uses the identity of the UE under test, and "O" indicates TTI in which the HS-SCCH-1 uses a different UE identity.		
Note1:	Measurement power offset "I" is configured by RRC accordingly and as defined in [8].			
Note2:	TF for HS-PDSCH is configured according to the reported CQI statistics. TF based on median CQI, median CQI -1, median CQI+2 are used. Other physical channel parameters are configured according to the CQI mapping table described in TS25.214			
Note 3:	HS-PDSCH E_c/I_{or} is decreased according to reference power adjustment Δ described in TS 25.214.			
Note 4:	For any given transport format the power of the HS-SCCH and HS-PDSCH shall be transmitted continuously with constant power.			

The reference for this requirement is TS 25.101 [1] clause 9.3.1.1.

9.3.1.3 Test purpose

To verify that the variance of the CQI reports when using TF based on CQI 16 is within the limits defined and that a BLER of 10% falls between the TF based on Median CQI-1 and the TF based on Median CQI TF or between the TF based on Median CQI and the TF based on Median CQI+2.

9.3.1.4 Method of test

9.3.1.4.1 Initial conditions

Test environment: normal; see clauses G.2.1 and G.2.2.

Frequencies to be tested: mid range; see clause G.2.4.

1. Connect SS and an AWGN noise source to the UE antenna connector as shown in figure A.9.
2. Set Ack/Nack handling at the SS such that regardless of the response from the UE (Ack, Nack or DTX) new data is sent each time, this is because HARQ transmissions are set to one, i.e. no re-transmission of failed blocks. The sending of new data means that for each HARQ process the new data indicator bit in the HS-SCCH toggles for consecutive transmissions.

9.3.1.4.2 Procedure

- 1) Set up an HSDPA call with looping back 12.2kbps RMC according to TS 34.108 [3] clause 7.3.6 with levels according to table E.5.0, and with the following exceptions in the RADIO BEARER SETUP message.

Table 9.3.1.2 Contents of RADIO BEARER SETUP message: AM or UM (HSDPA)

Information Element	Value/Remark
Downlink HS-PDSCH Information - HS-SCCH Info - CHOICE mode - DL Scrambling Code - HS-SCCH Channelisation Code Info - HS-SCCH Channelisation Code - Measurement Feedback Info - CHOICE mode - POhsdsch	FDD 2 FDD Compatible with the values in table 9.3.1.1 and according to TS 25.214 [5] clause 6A.2
- Added or Reconfigured DL TrCH information - CHOICE DL parameters - HARQ Info - Number of Processes - Added or reconfigured MAC-d flow - MAC-hs queue to add or reconfigure list - MAC-d PDU size Info - MAC-d PDU size - MAC-d PDU size index - MAC-d PDU size - MAC-d PDU size index	HS-DSCH 2 (one queue) 112 bits (Note 1) 0 448 bits (Note 1) 1
Note 1:	For UE Categories 1-6, 11 and 12, MAC-d PDU size of 112 is used. For other UE categories, MAC-d PDU sizes of 112 and 448 are used. Less than CQI value of 23 according to [5], 112 is used, and above the CQI values, 448 is used.

- 2) Set test conditions according to test 1 in table 9.3.1.1. The configuration of the downlink channels is defined in table E.5.1.

Note: The following part of the procedure will test if the UE reports a limited range of CQI values under the predefined channel conditions.

- 3) The SS shall send the TF according to CQI value 16 and keep it regardless of the CQI value sent by the UE. Continue transmission of the HS-PDSCH until 2000 CQI reports have been gathered. In this process the SS collects CQI reports every 2 ms and also cases where UE transmits nothing in its CQI field (CQI0) are counted as CQI reports.
- 4) Set up a relative frequency distribution for the CQI-values, reported. Calculate the median value (Median CQI is the CQI that is at or crosses 50% distribution from the lower CQI side). This CQI-value is declared as Median CQI value,
- 5) If 1800 or more of the CQI values are in the range $(\text{Median CQI} - 2) \leq \text{Median CQI} \leq (\text{Median CQI} + 2)$ then continue with step 6), otherwise fail the UE.

Note: The following part of the procedure will test if BLER versus CQI has the correct sense.

- 6) The SS shall transmit the TF according to the median-CQI value and shall not react to the UE's CQI reports. For any HSDPA block transmitted by the SS, record the associated ACK, NACK and statDTX responses. The responses are then filtered as follows: for the sequence of responses for each HARQ process, discard all the statDTX responses. If the number of consecutive discarded statDTX for any one process is an odd number including one, also discard the next response for that HARQ process regardless whether it is an ACK or NACK. Continue to gather data until the number of filtered ACK+NACK responses reaches 1000.

For the filtered ACK and NACK responses if the ratio $(\text{NACK} / \text{ACK} + \text{NACK}) < 0.1$ then goto step 7), otherwise goto step 8)

- 7) The SS shall transmit the TF according to the median-CQI+2 value and shall not react to the UE's CQI reports. For any HSDPA block, transmitted by the SS, record and filter the ACK, NACK and statDTX responses as in step 6 until 1000 filtered ACK+NACK responses are gathered.

If the ratio $(\text{NACK} / \text{ACK} + \text{NACK}) \geq 0.1$

then pass the UE, otherwise fail the UE

- 8) The SS shall transmit the TF according to the median-CQI-1 value and shall not react to the UE's CQI value. For any HSDPA block, transmitted by the SS, record and filter the ACK, NACK and statDTX responses as in step 6 until 1000 filtered ACK+NACK responses are gathered.

If the ratio $(\text{NACK} / \text{ACK} + \text{NACK}) < 0.1$

then pass the UE, otherwise fail the UE.

Note: The statistical selectivity based on 1000 samples is not sufficient to distinguish between $\text{BLER} < 0.1$ and > 0.1 . However, it is assumed that the difference between

[true BLER on Median CQI - true BLER on (Median CQI + 2)] and
[true BLER on Median CQI - true BLER on (Median CQI - 1)]

is large enough to exceed the statistical uncertainty and hence the measurement can indicate the correct sense of BLER.

- 9) Repeat the same procedure (steps 3 to 8) with test conditions according to the table 9.3.1.1 for Test 2 and Test 3.

9.3.1.5 Test Requirements

The pass fail decision is as specified in the test procedure in clause 9.3.1.4.2.

There are no parameters in the test setup or measurement process whose variation impacts the results so there are no applicable test tolerances for this test.

9.3.2 Single Link Performance - Fading Propagation Conditions

9.3.2.1 Definition and applicability

The reporting accuracy of the channel quality indicator (CQI) under fading environments is determined by the BLER performance using the transport format indicated by the reported CQI median.

The requirements and this test apply to all types of UTRA for the FDD UE that support HSDPA.

9.3.2.2 Minimum requirements

For the parameters specified in Table 9.3.2.1, and using the downlink physical channels specified in table E.5.1, the requirements are specified in terms of maximum BLERs at particular reported CQIs when transmitting a fixed transport format given by the CQI median as shown in Table 9.3.2.2. The BLER at a particular reported CQI is obtained by associating a particular CQI reference measurement period with the HS-PDSCH subframe overlapping with the end of this CQI reference measurement period and calculating the fraction of erroneous HS-PDSCH subframes.

Table 9.3.2.1: Test Parameters for CQI test in fading – single link

Parameter	Unit	Test 1	Test 2
HS-PDSCH E_c/I_{or}	dB	-8	-4
\hat{I}_{or}/I_{oc}	dB	0	5
I_{oc}	dBm/3.84 MHz	-60	
Phase reference	-	P-CPICH	
HS-SCCH_1 E_c/I_{or}	dB	-8.5	
DPCH E_c/I_{or}	dB	-6	
Maximum number of H-ARQ transmission	-	1	
Number of HS-SCCH set to be monitored	-	1	
CQI feedback cycle	ms	2	
CQI repetition factor	-	1	
HS-SCCH-1 signalling pattern	-	To incorporate inter-TTI=3 the six sub-frame HS-SCCH-1 signalling pattern shall be "...XOOXOO...", where "X" indicates TTI in which the HS-SCCH-1 uses the identity of the UE under test, and "O" indicates TTI in which the HS-SCCH-1 uses a different UE identity.	
Propagation Channel		Case 8	
Note1:	Measurement power offset "I" is configured by RRC accordingly and as defined in [8]		
Note2:	TF for HS-PDSCH is configured according to the reported CQI statistics. TF based on median CQI is used. Other physical channel parameters are configured according to the CQI mapping table described in TS25.214		
Note 3:	HS-PDSCH E_c/I_{or} is decreased according to reference power adjustment Δ described in TS 25.214.		
Note 4:	For any given transport format the power of the HS-SCCH and HS-PDSCH shall be transmitted continuously with constant power.		

Table 9.3.2.2: Minimum requirement for CQI test in fading – single link

Reported CQI	Maximum BLER	
	Test 1	Test2
CQI median	60%	60%
CQI median + 3	15%	15%

The reference for this requirement is TS 25.101 [1] clause 9.3.1.2.

9.3.2.3 Test purpose

To verify that when using the TF based on the Median CQI that the BLER for blocks associated with CQI reports of Median CQI is $\leq 60\%$ and that the BLER for blocks associated with CQI reports of Median CQI+3 is $\leq 15\%$.

9.3.2.4 Method of test

9.3.2.4.1 Initial conditions

Test environment: normal; see clauses G.2.1 and G.2.2.

Frequencies to be tested: mid range; see clause G.2.4.

- 1) Connect SS, multipath fading simulator and an AWGN noise source to the UE antenna connector as shown in figure A.10.
- 2) Set Ack/Nack handling at the SS such that regardless of the response from the UE (Ack, Nack or DTX) new data is sent each time, this is because HARQ transmissions are set to one, i.e. no re-transmission of failed blocks. The

sending of new data means that for each HARQ process the new data indicator bit in the HS-SCCH toggles for consecutive transmissions.

9.3.2.4.2 Procedure

- 1) Set up an HSDPA call with looping back 12.2kbps RMC according to TS 34.108 [3] clause 7.3.6 with levels according to table E.5.0, and with the following exceptions in the RADIO BEARER SETUP message. Set test conditions according to test 1 in table 9.3.2.1. The configuration of the downlink channels is defined in table E.5.1.

Table 9.3.2.3 Contents of RADIO BEARER SETUP message: AM or UM (HSDPA)

Information Element	Value/Remark
Downlink HS-PDSCH Information	
- HS-SCCH Info	FDD
- CHOICE mode	
- DL Scrambling Code	
- HS-SCCH Channelisation Code Info	2
- HS-SCCH Channelisation Code	
- Measurement Feedback Info	
- CHOICE mode	FDD
- POhsdsch	Compatible with the values in table 9.3.2.1 and according to TS 25.214 [5] clause 6A.2
- Added or Reconfigured DL TrCH information	HS-DSCH
- CHOICE DL parameters	
- HARQ Info	
- Number of Processes	2
- Added or reconfigured MAC-d flow	
- MAC-hs queue to add or reconfigure list	(one queue)
- MAC-d PDU size Info	
- MAC-d PDU size	112 bits (Note 1)
- MAC-d PDU size index	0
- MAC-d PDU size	448 bits (Note 1)
- MAC-d PDU size index	1
Note 1:	For UE Categories 1-6, 11 and 12, MAC-d PDU size of 112 is used. For other UE categories, MAC-d PDU sizes of 112 and 448 are used. Less than CQI value of 23 according to [5], 112 is used, and above the CQI values, 448 is used.

- 2) The SS shall send TF according to CQI value 16 and keep it regardless of the CQI value sent by the UE. Continue transmission of the HS-PDSCH until 8200 CQI reports have been gathered. In this process the SS collects CQI reports every 2 ms and also cases where UE transmits nothing in its CQI field (CQI0) are counted as CQI reports.
- 3) Set up a relative frequency distribution for the reported CQI values. Calculate the median value (Median CQI is the CQI that is at or crosses 50% distribution from the lower CQI side). This CQI-value is declared as Median CQI value,
- 4) The SS shall transmit the TF according to the median-CQI value and shall not react to the UE's reported CQI value. For any HSDPA block transmitted by the SS, record the ACK, NACK and statDTX responses, and associate with each response the CQI report that corresponds to the CQI evaluation period in which the end of the HS-PDSCH is received. (See figure 9.3.2.1 below.)

The responses are then filtered as follows: for the sequence of responses for each HARQ process, discard all the statDTX responses. If the number of consecutive discarded statDTX for any one process is an odd number including one, also discard the next response for that HARQ process regardless whether it is an ACK or NACK. Continue to gather and filter responses until 1000 filtered responses with CQI = Median CQI and 1000 filtered responses with CQI = Median CQI + 3 have been collected.

- 5) Measure BLER as described below.

In the test there are two BLER requirements to be tested:

R1: HSDPA block with corresponding reported CQI = Median CQI BLER ≤ 60%

R2: HSDPA block with corresponding reported CQI = Median CQI + 3 BLER ≤ 15%

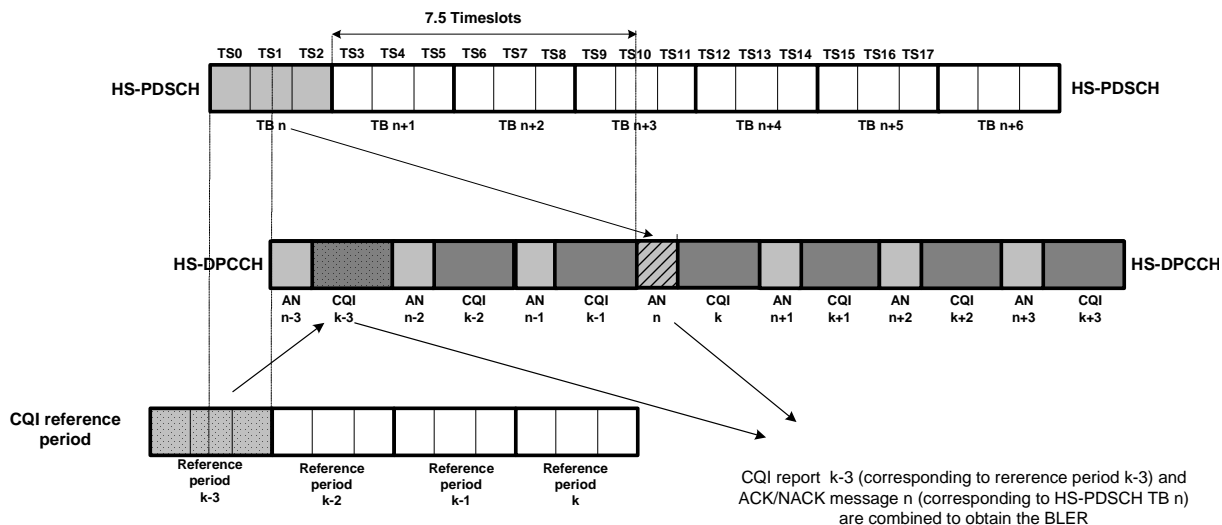

Figure 9.3.2.1 Combination of ACK/NACK message and the CQI report for BLER calculation

For each set of samples R1 and R2 the BLER = (NACK) / (ACK + NACK)

Repeat the same procedure with test conditions according to the test 2 of table 9.3.2.1.

9.3.2.5 Test Requirements

The measured BLER shall not exceed values specified in table 9.3.2.2.

There are no parameters in the test setup or measurement process whose variation impacts the results so there are no applicable test tolerances for this test.

9.3.3 Open Loop Diversity Performance - AWGN Propagation Conditions

9.3.3.1 Definition and applicability

The reporting accuracy of channel quality indicator (CQI) under AWGN environments is determined by the reporting variance and the BLER performance using the transport format indicated by the reported CQI median.

The requirements and this test apply for Release 6 to all types of UTRA for the FDD UE that support HSDPA.

9.3.3.2 Minimum requirements

For the parameters specified in Table 9.3.3.1, and using the downlink physical channels specified in table E.5.2 the reported CQI value shall be in the range of +/-2 of the reported median more than 90% of the time. If the HS-PDSCH BLER using the transport format indicated by median CQI is less than or equal to 0.1, the BLER using the transport format indicated by the (median CQI +2) shall be greater than 0.1. If the HS-PDSCH BLER using the transport format indicated by the median CQI is greater than 0.1, the BLER using transport format indicated by (median CQI -1) shall be less than or equal to 0.1.

Table 9.3.3.1: Test Parameters for CQI test in AWGN – single link

Parameter	Unit	Test 1	Test 2	Test 3
\hat{I}_{or} / I_{oc}	dB	0	5	10
I_{oc}	dBm/3.84 MHz	-60		
Phase reference	-	P-CPICH		
HS-PDSCH E_c / I_{or}	dB	-3		
HS-SCCH_1 E_c / I_{or}	dB	-10		
DPCH E_c / I_{or}	dB	-10		
Maximum number of H-ARQ transmission	-	1		
Number of HS-SCCH set to be monitored	-	1		
CQI feedback cycle	ms	2		
CQI repetition factor	-	1		
HS-SCCH-1 signalling pattern	-	To incorporate inter-TTI=3 the six sub-frame HS-SCCH-1 signalling pattern shall be "...XOOXOO...", where "X" indicates TTI in which the HS-SCCH-1 uses the identity of the UE under test, and "O" indicates TTI in which the HS-SCCH-1 uses a different UE identity.		
Note1:	Measurement power offset "I" is configured by RRC accordingly and as defined in [8].			
Note2:	TF for HS-PDSCH is configured according to the reported CQI statistics. TF based on median CQI, median CQI -1, median CQI+2 are used. Other physical channel parameters are configured according to the CQI mapping table described in TS25.214			
Note 3:	HS-PDSCH E_c/I_{or} is decreased according to reference power adjustment Δ described in TS 25.214.			
Note 4:	For any given transport format the power of the HS-SCCH and HS-PDSCH shall be transmitted continuously with constant power.			

The reference for this requirement is TS 25.101 [1] clause 9.3.2.1.

9.3.3.3 Test purpose

To verify that the variance of the CQI reports when using TF based on CQI 16 is within the limits defined and that a BLER of 10% falls between the TF based on Median CQI-1 and the TF based on Median CQI TF or between the TF based on Median CQI and the TF based on Median CQI+2.

9.3.3.4 Method of test

9.3.3.4.1 Initial conditions

Test environment: normal; see clauses G.2.1 and G.2.2.

Frequencies to be tested: mid range; see clause G.2.4.

1. Connect SS and an AWGN noise source to the UE antenna connector as shown in figure A.12a.
2. Set Ack/Nack handling at the SS such that regardless of the response from the UE (Ack, Nack or DTX) new data is sent each time, this is because HARQ transmissions are set to one, i.e. no re-transmission of failed blocks. The sending of new data means that for each HARQ process the new data indicator bit in the HS-SCCH toggles for consecutive transmissions.

9.3.3.4.2 Procedure

- 1) Set up an HSDPA call with looping back 12.2kbps RMC according to TS 34.108 [3] clause 7.3.6 with the exceptions for information elements listed in table 9.3.3.2, with levels according to table E.5.0.
- 2) Set test conditions according to test 1 according table 9.3.3.1. The configuration of the downlink channels is defined in table E.5.2.

Note: The following part of the procedure will test if the UE reports a limited range of CQI values under the predefined channel conditions.

- 3) The SS shall send the TF according to CQI value 16 and keep it regardless of the CQI value sent by the UE. Continue transmission of the HS-PDSCH until 2000 CQI reports have been gathered. In this process the SS collects CQI reports every 2 ms and also cases where UE transmits nothing in its CQI field (CQI0) are counted as CQI reports.
- 4) Set up a relative frequency distribution for the CQI-values, reported. Calculate the median value (Median CQI is the CQI that is at or crosses 50% distribution from the lower CQI side). This CQI-value is declared as Median CQI value,
- 5) If 1800 or more of the CQI values are in the range $(\text{Median CQI} - 2) \leq \text{Median CQI} \leq (\text{Median CQI} + 2)$ then continue with step 6), otherwise fail the UE.

Note: The following part of the procedure will test if BLER versus CQI has the correct sense.

- 6) The SS shall transmit the TF according to the median-CQI value and shall not react to the UE's CQI reports. For any HSDPA block transmitted by the SS, record the associated ACK, NACK and statDTX responses. The responses are then filtered as follows: for the sequence of responses for each HARQ process, discard all the statDTX responses. If the number of consecutive discarded statDTX for any one process is an odd number including one, also discard the next response for that HARQ process regardless whether it is an ACK or NACK. Continue to gather data until the number of filtered ACK+NACK responses reaches 1000.

For the filtered ACK and NACK responses if the ratio $(\text{NACK} / \text{ACK} + \text{NACK}) < 0.1$ then goto step 7), otherwise goto step 8)

- 7) The SS shall transmit the TF according to the median-CQI+2 value and shall not react to the UE's CQI reports. For any HSDPA block, transmitted by the SS, record and filter the ACK, NACK and statDTX responses as in step 6 until 1000 filtered ACK+NACK responses are gathered.

If the ratio $(\text{NACK} / \text{ACK} + \text{NACK}) \geq 0.1$

then pass the UE, otherwise fail the UE

- 8) The SS shall transmit the TF according to the median-CQI-1 value and shall not react to the UE's CQI value. For any HSDPA block, transmitted by the SS, record and filter the ACK, NACK and statDTX responses as in step 6 until 1000 filtered ACK+NACK responses are gathered.

If the ratio $(\text{NACK} / \text{ACK} + \text{NACK}) < 0.1$

then pass the UE, otherwise fail the UE.

Note: The statistical selectivity based on 1000 samples is not sufficient to distinguish between $\text{BLER} < 0.1$ and > 0.1 . However, it is assumed that the difference between

[true BLER on Median CQI - true BLER on (Median CQI + 2)] and
[true BLER on Median CQI - true BLER on (Median CQI - 1)]

is large enough to exceed the statistical uncertainty and hence the measurement can indicate the correct sense of BLER.

- 9) Repeat the same procedure (steps 3 to 8) with test conditions according to the table 9.3.3.1 for Test 2 and Test 3.

Table 9.3.3.2: Specific Message Contents for open-loop transmit diversity mode

SYSTEM INFORMATION BLOCK TYPE5

Information Element	Value/remark
PRACH system information list - AICH info - STTD Indicator	TRUE
Secondary CCPCH system information - PICH info - STTD Indicator - Secondary CCPCH info - STTD Indicator	TRUE TRUE
Primary CCPCH info - CHOICE mode - TX Diversity indicator	FDD TRUE

SYSTEM INFORMATION BLOCK TYPE11

Information Element	Value/remark
New intra-frequency cells - Intra-frequency cell id	1
- TX Diversity indicator	TRUE

RRC CONNECTION SETUP

Information Element	Value/remark
Downlink information common for all radio links - CHOICE mode - TX Diversity Mode	FDD STTD
Downlink DPCH info for each RL - CHOICE mode - Downlink DPCH info for each RL - Closed loop timing adjustment mode	FDD 1

RADIO BEARER SETUP for Closed test loop mode1

Information Element	Value/remark
Downlink information common for all radio links - CHOICE mode - TX Diversity Mode	FDD STTD
Downlink DPCH info for each RL - CHOICE mode - Downlink DPCH info for each RL - Closed loop timing adjustment mode	FDD 1

RADIO BEARER SETUP message: AM or UM (HSDPA)

Information Element	Value/remark
Downlink HS-PDSCH Information - HS-SCCH Info - CHOICE mode - DL Scrambling Code - HS-SCCH Channelisation Code Info - HS-SCCH Channelisation Code - Measurement Feedback Info - CHOICE mode - POhsdsch	FDD 2 FDD Compatible with the values in table 9.3.3.1 and according to TS 25.214 [5] clause 6A.2
- Added or Reconfigured DL TrCH information - CHOICE DL parameters - HARQ Info - Number of Processes - Added or reconfigured MAC-d flow - MAC-hs queue to add or reconfigure list - MAC-d PDU size Info - MAC-d PDU size	HS-DSCH 2 (one queue) 112 bits (Note 1)
- MAC-d PDU size index	0
- MAC-d PDU size	448 bits (Note 1)
- MAC-d PDU size index	1
Downlink information common for all radio links - CHOICE mode - TX Diversity Mode	FDD STTD
Downlink DPCH info for each RL - CHOICE mode - Downlink DPCH info for each RL - Closed loop timing adjustment mode	FDD 1
Note 1: For UE Categories 1-6, 11 and 12, MAC-d PDU size of 112 is used. For other UE categories, MAC-d PDU sizes of 112 and 448 are used. Less than CQI value of 23 according to [5], 112 is used, and above the CQI values, 448 is used.	

9.3.3.5 Test Requirements

The pass fail decision is as specified in the test procedure in clause 9.3.3.4.2.

There are no parameters in the test setup or measurement process whose variation impacts the results so there are no applicable test tolerances for this test.

9.3.4 Open Loop Diversity Performance - Fading Propagation Conditions

9.3.4.1 Definition and applicability

The reporting accuracy of the channel quality indicator (CQI) under fading environments is determined by the BLER performance using the transport format indicated by the reported CQI median.

The requirements and this test apply for Release 6 to all types of UTRA for the FDD UE that support HSDPA.

9.3.4.2 Minimum requirements

For the parameters specified in Table 9.3.4.1, and using the downlink physical channels specified in table E.5.2, the requirements are specified in terms of maximum BLERs at particular reported CQIs when transmitting a fixed transport format given by the CQI median as shown in Table 9.3.4.2.. The BLER at a particular reported CQI is obtained by associating a particular CQI reference measurement period with the HS-PDSCH subframe overlapping with the end of this CQI reference measurement period and calculating the fraction of erroneous HS-PDSCH subframes.

Table 9.3.4.1: Test Parameters for CQI test in fading – single link

Parameter	Unit	Test 1	Test 2
HS-PDSCH E_c/I_{or}	dB	-8	-4
\hat{I}_{or}/I_{oc}	dB	0	5
I_{oc}	dBm/3.84 MHz	-60	
Phase reference	-	P-CPICH	
HS-SCCH_1 E_c/I_{or}	dB	-8.5	
DPCH E_c/I_{or}	dB	-6	
Maximum number of H-ARQ transmission	-	1	
Number of HS-SCCH set to be monitored	-	1	
CQI feedback cycle	ms	2	
CQI repetition factor	-	1	
HS-SCCH-1 signalling pattern	-	To incorporate inter-TTI=3 the six sub-frame HS-SCCH-1 signalling pattern shall be "...XOOXOO...", where "X" indicates TTI in which the HS-SCCH-1 uses the identity of the UE under test, and "O" indicates TTI in which the HS-SCCH-1 uses a different UE identity.	
Propagation Channel		Case 8	
Note1:	Measurement power offset "I" is configured by RRC accordingly and as defined in [8]		
Note2:	TF for HS-PDSCH is configured according to the reported CQI statistics. TF based on median CQI is used. Other physical channel parameters are configured according to the CQI mapping table described in TS25.214		
Note 3:	HS-PDSCH E_c/I_{or} is decreased according to reference power adjustment Δ described in TS 25.214.		
Note 4:	For any given transport format the power of the HS-SCCH and HS-PDSCH shall be transmitted continuously with constant power.		

Table 9.3.4.2: Minimum requirement for CQI test in fading – single link

Reported CQI	Maximum BLER	
	Test 1	Test2
CQI median	60%	60%
CQI median + 3	15%	15%

The reference for this requirement is TS 25.101 [1] clause 9.3.2.2.

9.3.4.3 Test purpose

To verify that when using the TF based on the Median CQI that the BLER for blocks associated with CQI reports of Median CQI is $\leq 60\%$ and that the BLER for blocks associated with CQI reports of Median CQI+3 is $\leq 15\%$.

9.3.4.4 Method of test

9.3.4.4.1 Initial conditions

Test environment: normal; see clauses G.2.1 and G.2.2.

Frequencies to be tested: mid range; see clause G.2.4.

- 1) Connect SS, multipath fading simulator and an AWGN noise source to the UE antenna connector as shown in figure A.12.
- 2) Set Ack/Nack handling at the SS such that regardless of the response from the UE (Ack, Nack or DTX) new data is sent each time, this is because HARQ transmissions are set to one, i.e. no re-transmission of failed blocks. The

sending of new data means that for each HARQ process the new data indicator bit in the HS-SCCH toggles for consecutive transmissions.

- 3) Setup the fading simulators with fading conditions as described in table D.2.2.1.A and clause D.2.7.

9.3.4.4.2 Procedure

- 1) Set up an HSDPA call with looping back 12.2kbps RMC according to TS 34.108 [3] clause 7.3.6 with the exceptions for information elements listed in table 9.3.4.3, with levels according to table E.5.0. Set test conditions according to test 1 according table 9.3.4.1. The configuration of the downlink channels is defined in table E.5.2.
- 2) The SS shall send TF according to CQI value 16 and keep it regardless of the CQI value sent by the UE. Continue transmission of the HS-PDSCH until 8200 CQI reports have been gathered. In this process the SS collects CQI reports every 2 ms and also cases where UE transmits nothing in its CQI field (CQI0) are counted as CQI reports.
- 3) Set up a relative frequency distribution for the reported CQI values. Calculate the median value (Median CQI is the CQI that is at or crosses 50% distribution from the lower CQI side). This CQI-value is declared as Median CQI value,
- 4) The SS shall transmit the TF according to the median-CQI value and shall not react to the UE's reported CQI value. For any HSDPA block transmitted by the SS, record the ACK, NACK and statDTX responses, and associate with each response the CQI report that corresponds to the CQI evaluation period in which the end of the HS-PDSCH is received. (See figure 9.3.4.1 below.)

The responses are then filtered as follows: for the sequence of responses for each HARQ process, discard all the statDTX responses. If the number of consecutive discarded statDTX for any one process is an odd number including one, also discard the next response for that HARQ process regardless whether it is an ACK or NACK. Continue to gather and filter responses until 1000 filtered responses with CQI = Median CQI and 1000 filtered responses with CQI = Median CQI + 3 have been collected.

- 5) Measure BLER as described below.

In the test there are two BLER requirements to be tested:

R1: HSDPA block with corresponding reported CQI = Median CQI BLER ≤ 60%

R2: HSDPA block with corresponding reported CQI = Median CQI + 3 BLER ≤ 15%

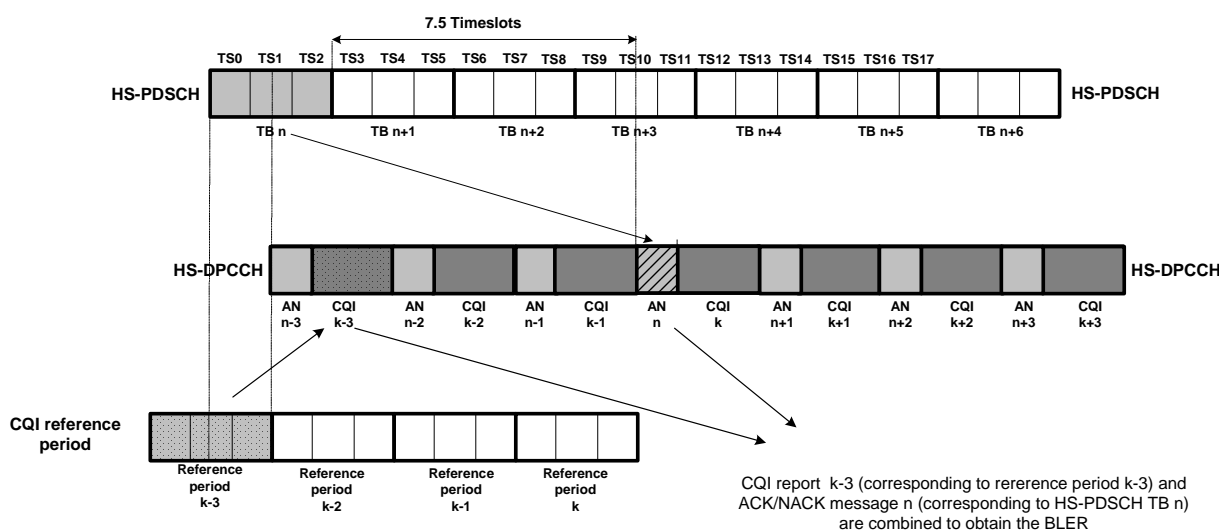

Figure 9.3.4.1 Combination of ACK/NACK message and the CQI report for BLER calculation

For each set of events R1 and R2 the BLER = (NACK) / (ACK + NACK)

Repeat the same procedure with test conditions according to the test 2 of table 9.3.4.1.

Table 9.3.4.3: Specific Message Contents for open-loop transmit diversity mode

SYSTEM INFORMATION BLOCK TYPE5

Information Element	Value/remark
PRACH system information list - AICH info - STTD Indicator	TRUE
Secondary CCPCH system information - PICH info - STTD Indicator - Secondary CCPCH info - STTD Indicator	TRUE TRUE
Primary CCPCH info - CHOICE mode - TX Diversity indicator	FDD TRUE

SYSTEM INFORMATION BLOCK TYPE11

Information Element	Value/remark
New intra-frequency cells - Intra-frequency cell id	1
- TX Diversity indicator	TRUE

RRC CONNECTION SETUP

Information Element	Value/remark
Downlink information common for all radio links - CHOICE mode - TX Diversity Mode	FDD STTD
Downlink DPCH info for each RL - CHOICE mode - Downlink DPCH info for each RL - Closed loop timing adjustment mode	FDD 1

RADIO BEARER SETUP for Closed test loop mode1

Information Element	Value/remark
Downlink information common for all radio links - CHOICE mode - TX Diversity Mode	FDD STTD
Downlink DPCH info for each RL - CHOICE mode - Downlink DPCH info for each RL - Closed loop timing adjustment mode	FDD 1

RADIO BEARER SETUP message: AM or UM (HSDPA)

Information Element	Value/remark
Downlink HS-PDSCH Information - HS-SCCH Info - CHOICE mode - DL Scrambling Code - HS-SCCH Channelisation Code Info - HS-SCCH Channelisation Code - Measurement Feedback Info - CHOICE mode - POhsdsch	FDD 2 FDD Compatible with the values in table 9.3.4.1 and according to TS 25.214 [5] clause 6A.2
- Added or Reconfigured DL TrCH information - CHOICE DL parameters - HARQ Info - Number of Processes - Added or reconfigured MAC-d flow - MAC-hs queue to add or reconfigure list - MAC-d PDU size Info - MAC-d PDU size	HS-DSCH 2 (one queue) 112 bits (Note 1)
- MAC-d PDU size index	0
- MAC-d PDU size	448 bits (Note 1)
- MAC-d PDU size index	1
Downlink information common for all radio links - CHOICE mode - TX Diversity Mode	FDD STTD
Downlink DPCH info for each RL - CHOICE mode - Downlink DPCH info for each RL - Closed loop timing adjustment mode	FDD 1
Note 1: For UE Categories 1-6, 11 and 12, MAC-d PDU size of 112 is used. For other UE categories, MAC-d PDU sizes of 112 and 448 are used. Less than CQI value of 23 according to [5], 112 is used, and above the CQI values, 448 is used.	

9.3.4.5 Test Requirements

The measured BLER shall not exceed values specified in table 9.3.4.2.

There are no parameters in the test setup or measurement process whose variation impacts the results so there are no applicable test tolerances for this test.

9.3.5 Closed Loop Diversity Performance - AWGN Propagation Conditions

9.3.5.1 Definition and applicability

The reporting accuracy of channel quality indicator (CQI) under AWGN environments is determined by the reporting variance and the BLER performance using the transport format indicated by the reported CQI median.

The requirements and this test apply for Release 6 to all types of UTRA for the FDD UE that support HSDPA.

9.3.5.2 Minimum requirements

For the parameters specified in Table 9.3.5.1, and using the downlink physical channels specified in table E.5.3 the reported CQI value shall be in the range of ± 2 of the reported median more than 90% of the time. If the HS-PDSCH BLER using the transport format indicated by median CQI is less than or equal to 0.1, the BLER using the transport format indicated by the (median CQI +2) shall be greater than 0.1. If the HS-PDSCH BLER using the transport format indicated by the median CQI is greater than 0.1, the BLER using transport format indicated by (median CQI -1) shall be less than or equal to 0.1.

Table 9.3.5.1: Test Parameters for CQI test in AWGN – single link

Parameter	Unit	Test 1	Test 2	Test 3
\hat{I}_{or} / I_{oc}	dB	0	5	10
I_{oc}	dBm/3.84 MHz	-60		
Phase reference	-	P-CPICH		
HS-PDSCH E_c / I_{or}	dB	-3		
HS-SCCH_1 E_c / I_{or}	dB	-10		
DPCH E_c / I_{or}	dB	-10		
Maximum number of H-ARQ transmission	-	1		
Number of HS-SCCH set to be monitored	-	1		
CQI feedback cycle	ms	2		
CQI repetition factor	-	1		
Feedback Error Rate	%	0		
Closed loop timing adjustment mode		1		
HS-SCCH-1 signalling pattern	-	To incorporate inter-TTI=3 the six sub-frame HS-SCCH-1 signalling pattern shall be "...XOOXOO...", where "X" indicates TTI in which the HS-SCCH-1 uses the identity of the UE under test, and "O" indicates TTI in which the HS-SCCH-1 uses a different UE identity.		
Note1:	Measurement power offset "T" is configured by RRC accordingly and as defined in [8].			
Note2:	TF for HS-PDSCH is configured according to the reported CQI statistics. TF based on median CQI, median CQI -1, median CQI+2 are used. Other physical channel parameters are configured according to the CQI mapping table described in TS25.214			
Note 3:	HS-PDSCH E_c/I_{or} is decreased according to reference power adjustment Δ described in TS 25.214.			
Note 4:	For any given transport format the power of the HS-SCCH and HS-PDSCH shall be transmitted continuously with constant power.			

The reference for this requirement is TS 25.101 [1] clause 9.3.3.1.

9.3.5.3 Test purpose

To verify that the variance of the CQI reports when using TF based on CQI 16 is within the limits defined and that a BLER of 10% falls between the TF based on Median CQI-1 and the TF based on Median CQI TF or between the TF based on Median CQI and the TF based on Median CQI+2.

9.3.5.4 Method of test

9.3.5.4.1 Initial conditions

Test environment: normal; see clauses G.2.1 and G.2.2.

Frequencies to be tested: mid range; see clause G.2.4.

1. Connect SS and an AWGN noise source to the UE antenna connector as shown in figure A.12a.
2. Set Ack/Nack handling at the SS such that regardless of the response from the UE (Ack, Nack or DTX) new data is sent each time, this is because HARQ transmissions are set to one, i.e. no re-transmission of failed blocks. The sending of new data means that for each HARQ process the new data indicator bit in the HS-SCCH toggles for consecutive transmissions.

9.3.5.4.2 Procedure

- 1) Set up an HSDPA call with looping back 12.2kbps RMC according to TS 34.108 [3] clause 7.3.6 with the exceptions for information elements listed in table 9.3.5.2, with levels according to table E.5.0.
- 2) Set test conditions according to test 1 according table 9.3.5.1. The configuration of the downlink channels is defined in table E.5.3.

Note: The following part of the procedure will test if the UE reports a limited range of CQI values under the predefined channel conditions.

- 3) The SS shall send the TF according to CQI value 16 and keep it regardless of the CQI value sent by the UE. Continue transmission of the HS-PDSCH until 2000 CQI reports have been gathered. In this process the SS collects CQI reports every 2 ms and also cases where UE transmits nothing in its CQI field (CQI0) are counted as CQI reports.
- 4) Set up a relative frequency distribution for the CQI-values, reported. Calculate the median value (Median CQI is the CQI that is at or crosses 50% distribution from the lower CQI side). This CQI-value is declared as Median CQI value,
- 5) If 1800 or more of the CQI values are in the range $(\text{Median CQI} - 2) \leq \text{Median CQI} \leq (\text{Median CQI} + 2)$ then continue with step 6), otherwise fail the UE.

Note: The following part of the procedure will test if BLER versus CQI has the correct sense.

- 6) The SS shall transmit the TF according to the median-CQI value and shall not react to the UE's CQI reports. For any HSDPA block transmitted by the SS, record the associated ACK, NACK and statDTX responses. The responses are then filtered as follows: for the sequence of responses for each HARQ process, discard all the statDTX responses. If the number of consecutive discarded statDTX for any one process is an odd number including one, also discard the next response for that HARQ process regardless whether it is an ACK or NACK. Continue to gather data until the number of filtered ACK+NACK responses reaches 1000.

For the filtered ACK and NACK responses if the ratio $(\text{NACK} / \text{ACK} + \text{NACK}) < 0.1$ then goto step 7), otherwise goto step 8)

- 7) The SS shall transmit the TF according to the median-CQI+2 value and shall not react to the UE's CQI reports. For any HSDPA block, transmitted by the SS, record and filter the ACK, NACK and statDTX responses as in step 6 until 1000 filtered ACK+NACK responses are gathered.

If the ratio $(\text{NACK} / \text{ACK} + \text{NACK}) \geq 0.1$

then pass the UE, otherwise fail the UE

- 8) The SS shall transmit the TF according to the median-CQI-1 value and shall not react to the UE's CQI value. For any HSDPA block, transmitted by the SS, record and filter the ACK, NACK and statDTX responses as in step 6 until 1000 filtered ACK+NACK responses are gathered.

If the ratio $(\text{NACK} / \text{ACK} + \text{NACK}) < 0.1$

then pass the UE, otherwise fail the UE.

Note: The statistical selectivity based on 1000 samples is not sufficient to distinguish between $\text{BLER} < 0.1$ and > 0.1 . However, it is assumed that the difference between

[true BLER on Median CQI - true BLER on (Median CQI + 2)] and
[true BLER on Median CQI - true BLER on (Median CQI - 1)]

is large enough to exceed the statistical uncertainty and hence the measurement can indicate the correct sense of BLER.

- 9) Repeat the same procedure (steps 3 to 8) with test conditions according to the table 9.3.5.1 for Test 2 and Test 3.

Table 9.3.5.2: Specific Message Contents for closed loop transmit diversity mode

SYSTEM INFORMATION BLOCK TYPE5

Information Element	Value/remark
PRACH system information list - AICH info - STTD Indicator	TRUE
Secondary CCPCH system information - PICH info - STTD Indicator - Secondary CCPCH info - STTD Indicator	TRUE TRUE
Primary CCPCH info - CHOICE mode - TX Diversity indicator	FDD TRUE

SYSTEM INFORMATION BLOCK TYPE11

Information Element	Value/remark
New intra-frequency cells - Intra-frequency cell id	1
- TX Diversity indicator	TRUE

RRC CONNECTION SETUP

Information Element	Value/remark
CHOICE channel requirement - Number of FBI bit	Uplink DPCH info 1
Downlink information common for all radio links - CHOICE mode - TX Diversity Mode	FDD Closed loop mode1
Downlink DPCH info for each RL - CHOICE mode - Downlink DPCH info for each RL - Closed loop timing adjustment mode	FDD 1

RADIO BEARER SETUP for Closed test loop mode1

Information Element	Value/remark
CHOICE channel requirement - Number of FBI bit	Uplink DPCH info 1
Downlink information common for all radio links - CHOICE mode - TX Diversity Mode	FDD Closed loop mode1
Downlink DPCH info for each RL - CHOICE mode - Downlink DPCH info for each RL - Closed loop timing adjustment mode	FDD 1

RADIO BEARER SETUP message: AM or UM (HSDPA)

Information Element	Value/remark
Downlink HS-PDSCH Information <ul style="list-style-type: none"> - HS-SCCH Info <ul style="list-style-type: none"> - CHOICE mode - DL Scrambling Code - HS-SCCH Channelisation Code Info <ul style="list-style-type: none"> - HS-SCCH Channelisation Code - Measurement Feedback Info <ul style="list-style-type: none"> - CHOICE mode - POhsdsch 	FDD 2 FDD Compatible with the values in table 9.3.5.1 and according to TS 25.214 [5] clause 6A.2
<ul style="list-style-type: none"> - Added or Reconfigured DL TrCH information <ul style="list-style-type: none"> - CHOICE DL parameters <ul style="list-style-type: none"> - HARQ Info <ul style="list-style-type: none"> - Number of Processes - Added or reconfigured MAC-d flow <ul style="list-style-type: none"> - MAC-hs queue to add or reconfigure list <ul style="list-style-type: none"> - MAC-d PDU size Info <ul style="list-style-type: none"> - MAC-d PDU size - MAC-d PDU size index - MAC-d PDU size - MAC-d PDU size index 	HS-DSCH 2 (one queue) 112 bits (Note 1) 0 448 bits (Note 1) 1
CHOICE channel requirement <ul style="list-style-type: none"> - Number of FBI bit 	Uplink DPCH info 1
Downlink information common for all radio links <ul style="list-style-type: none"> - CHOICE mode - TX Diversity Mode 	FDD Closed loop mode1
Downlink DPCH info for each RL <ul style="list-style-type: none"> - CHOICE mode - Downlink DPCH info for each RL <ul style="list-style-type: none"> - Closed loop timing adjustment mode 	FDD 1
Note 1: For UE Categories 1-6, 11 and 12, MAC-d PDU size of 112 is used. For other UE categories, MAC-d PDU sizes of 112 and 448 are used. Less than CQI value of 23 according to [5], 112 is used, and above the CQI values, 448 is used.	

9.3.5.5 Test Requirements

The pass fail decision is as specified in the test procedure in clause 9.3.5.4.2.

There are no parameters in the test setup or measurement process whose variation impacts the results so there are no applicable test tolerances for this test.

9.3.6 Closed Loop Diversity Performance - Fading Propagation Conditions

9.3.6.1 Definition and applicability

The reporting accuracy of the channel quality indicator (CQI) under fading environments is determined by the BLER performance using the transport format indicated by the reported CQI median.

The requirements and this test apply for Release 6 to all types of UTRA for the FDD UE that support HSDPA.

9.3.6.2 Minimum requirements

For the parameters specified in Table 9.3.6.1, and using the downlink physical channels specified in table E.5.3, the requirements are specified in terms of maximum BLERs at particular reported CQIs when transmitting a fixed transport format given by the CQI median as shown in Table 9.3.6.2.. The BLER at a particular reported CQI is obtained by associating a particular CQI reference measurement period with the HS-PDSCH subframe overlapping with the end of this CQI reference measurement period and calculating the fraction of erroneous HS-PDSCH subframes.

Table 9.3.6.1: Test Parameters for CQI test in fading – single link

Parameter	Unit	Test 1	Test 2
HS-PDSCH E_c/I_{or}	dB	-8	-4
\hat{I}_{or}/I_{oc}	dB	0	5
I_{oc}	dBm/3.84 MHz	-60	
Phase reference	-	P-CPICH	
HS-SCCH_1 E_c/I_{or}	dB	-8.5	
DPCH E_c/I_{or}	dB	-6	
Maximum number of H-ARQ transmission	-	1	
Number of HS-SCCH set to be monitored	-	1	
CQI feedback cycle	ms	2	
CQI repetition factor	-	1	
Feedback Error Rate	%	0	
Closed loop timing adjustment mode		1	
HS-SCCH-1 signalling pattern	-	To incorporate inter-TTI=3 the six sub-frame HS-SCCH-1 signalling pattern shall be "...XOOXOO...", where "X" indicates TTI in which the HS-SCCH-1 uses the identity of the UE under test, and "O" indicates TTI in which the HS-SCCH-1 uses a different UE identity.	
Propagation Channel		Case 8	
Note1:	Measurement power offset "Γ" is configured by RRC accordingly and as defined in [8]		
Note2:	TF for HS-PDSCH is configured according to the reported CQI statistics. TF based on median CQI is used. Other physical channel parameters are configured according to the CQI mapping table described in TS25.214		
Note3:	HS-PDSCH E_c/I_{or} is decreased according to reference power adjustment Δ described in TS 25.214.		
Note4:	For any given transport format the power of the HS-SCCH and HS-PDSCH shall be transmitted continuously with constant power.		

Table 9.3.6.2: Minimum requirement for CQI test in fading – single link

Reported CQI	Maximum BLER	
	Test 1	Test2
CQI median	60%	60%
CQI median + 3	15%	15%

The reference for this requirement is TS 25.101 [1] clause 9.3.3.2.

9.3.6.3 Test purpose

To verify that when using the TF based on the Median CQI that the BLER for blocks associated with CQI reports of Median CQI is $\leq 60\%$ and that the BLER for blocks associated with CQI reports of Median CQI+3 is $\leq 15\%$.

9.3.6.4 Method of test

9.3.6.4.1 Initial conditions

Test environment: normal; see clauses G.2.1 and G.2.2.

Frequencies to be tested: mid range; see clause G.2.4.

- 1) Connect SS, multipath fading simulator and an AWGN noise source to the UE antenna connector as shown in figure A.12.

- 2) Set Ack/Nack handling at the SS such that regardless of the response from the UE (Ack, Nack or DTX) new data is sent each time, this is because HARQ transmissions are set to one, i.e. no re-transmission of failed blocks.
- 3) Setup the fading simulators with fading conditions as described in table D.2.2.1.A and clause D.2.7.

9.3.6.4.2 Procedure

- 1) Set up an HSDPA call with looping back 12.2kbps RMC according to TS 34.108 [3] clause 7.3.6 with the exceptions for information elements listed in table 9.3.6.3, with levels according to table E.5.0. Set test conditions according to test 1 according table 9.3.6.1. The configuration of the downlink channels is defined in table E.5.3.
- 2) The SS shall send TF according to CQI value 16 and keep it regardless of the CQI value sent by the UE. Continue transmission of the HS-PDSCH until 8200 CQI reports have been gathered. In this process the SS collects CQI reports every 2 ms and also cases where UE transmits nothing in its CQI field (CQI0) are counted as CQI reports.
- 3) Set up a relative frequency distribution for the reported CQI values. Calculate the median value (Median CQI is the CQI that is at or crosses 50% distribution from the lower CQI side). This CQI-value is declared as Median CQI value,
- 4) The SS shall transmit the TF according to the median-CQI value and shall not react to the UE's reported CQI value. For any HSDPA block transmitted by the SS, record the ACK, NACK and statDTX responses, and associate with each response the CQI report that corresponds to the CQI evaluation period in which the end of the HS-PDSCH is received. (See figure 9.3.6.1 below.)

The responses are then filtered as follows: for the sequence of responses for each HARQ process, discard all the statDTX responses. If the number of consecutive discarded statDTX for any one process is an odd number including one, also discard the next response for that HARQ process regardless whether it is an ACK or NACK. Continue to gather and filter responses until 1000 filtered responses with CQI = Median CQI and 1000 filtered responses with CQI = Median CQI + 3 have been collected.

- 5) Measure BLER as described below.

In the test there are two BLER requirements to be tested:

R1: HSDPA block with corresponding reported CQI = Median CQI BLER ≤ 60%

R2: HSDPA block with corresponding reported CQI = Median CQI + 3 BLER ≤ 15%

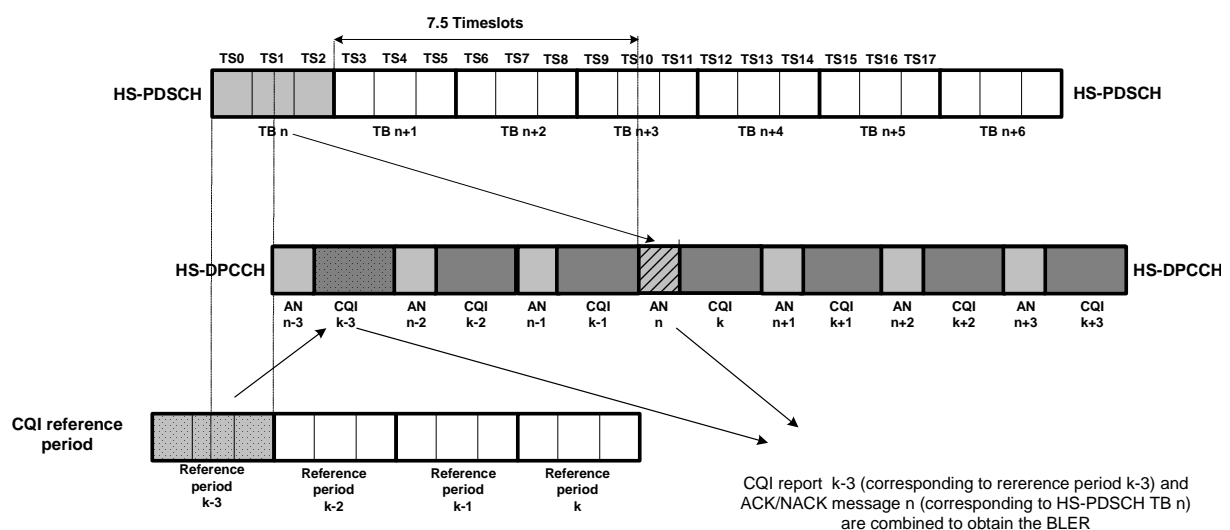

Figure 9.3.6.1 Combination of ACK/NACK message and the CQI report for BLER calculation

For each set of events R1 and R2 the BLER = (NACK) / (ACK + NACK)

Repeat the same procedure with test conditions according to the test 2 of table 9.3.6.1.

Table 9.3.6.3: Specific Message Contents for closed loop transmit diversity mode

SYSTEM INFORMATION BLOCK TYPE5

Information Element	Value/remark
PRACH system information list - AICH info - STTD Indicator	TRUE
Secondary CCPCH system information - PICH info - STTD Indicator - Secondary CCPCH info - STTD Indicator	TRUE TRUE
Primary CCPCH info - CHOICE mode - TX Diversity indicator	FDD TRUE

SYSTEM INFORMATION BLOCK TYPE11

Information Element	Value/remark
New intra-frequency cells - Intra-frequency cell id	1
- TX Diversity indicator	TRUE

RRC CONNECTION SETUP

Information Element	Value/remark
CHOICE channel requirement - Number of FBI bit	Uplink DPCH info 1
Downlink information common for all radio links - CHOICE mode - TX Diversity Mode	FDD Closed loop mode1
Downlink DPCH info for each RL - CHOICE mode - Downlink DPCH info for each RL - Closed loop timing adjustment mode	FDD 1

RADIO BEARER SETUP for Closed test loop mode1

Information Element	Value/remark
CHOICE channel requirement - Number of FBI bit	Uplink DPCH info 1
Downlink information common for all radio links - CHOICE mode - TX Diversity Mode	FDD Closed loop mode1
Downlink DPCH info for each RL - CHOICE mode - Downlink DPCH info for each RL - Closed loop timing adjustment mode	FDD 1

RADIO BEARER SETUP message: AM or UM (HSDPA)

Information Element	Value/remark
Downlink HS-PDSCH Information - HS-SCCH Info - CHOICE mode - DL Scrambling Code - HS-SCCH Channelisation Code Info - HS-SCCH Channelisation Code - Measurement Feedback Info - CHOICE mode - POhsdsch	FDD 2 FDD Compatible with the values in table 9.3.6.1 and according to TS 25.214 [5] clause 6A.2
- Added or Reconfigured DL TrCH information - CHOICE DL parameters - HARQ Info - Number of Processes - Added or reconfigured MAC-d flow - MAC-hs queue to add or reconfigure list - MAC-d PDU size Info - MAC-d PDU size - MAC-d PDU size index - MAC-d PDU size - MAC-d PDU size index	HS-DSCH 2 (one queue) 112 bits (Note 1) 0 448 1
CHOICE channel requirement - Number of FBI bit	Uplink DPCH info 1
Downlink information common for all radio links - CHOICE mode - TX Diversity Mode	FDD Closed loop mode1
Downlink DPCH info for each RL - CHOICE mode - Downlink DPCH info for each RL - Closed loop timing adjustment mode	FDD 1
Note 1: For UE Categories 1-6, 11 and 12, MAC-d PDU size of 112 is used. For other UE categories, MAC-d PDU sizes of 112 and 448 are used. Less than CQI value of 23 according to [5], 112 is used, and above the CQI values, 448 is used.	

9.3.6.5 Test Requirements

The measured BLER shall not exceed values specified in table 9.3.6.2.

There are no parameters in the test setup or measurement process whose variation impacts the results so there are no applicable test tolerances for this test.

9.4 HS-SCCH Detection Performance

9.4.1 Single Link Performance

9.4.1.1 Definition and applicability

The detection performance of the HS-SCCH is determined by the probability of event E_m , which is declared when the UE is signalled on HS-SCCH-1, but DTX is observed in the corresponding HS-DPCCH ACK/NACK field. The probability of event E_m is denoted $P(E_m)$.

The requirements and this test apply to all types of UTRA for FDD UE that support HSDPA.

9.4.1.2 Minimum requirements

For the parameters specified in Table 9.4.1.1, for each value of HS-SCCH-1 E_c/I_{or} specified in Table 9.4.1.2 the measured $P(E_m)$ shall be less than or equal to the corresponding specified value of $P(E_m)$.

Table 9.4.1.1: Test parameters for HS-SCCH detection – single link

Parameter	Unit	Test 1	Test 2	Test 3
I_{oc}	dBm/3.84 MHz	-60		
Phase reference	-	P-CPICH		
P-CPICH E_c/I_{or}	dB	-10		
HS-SCCH UE Identity ($x_{ue,1}, x_{ue,2}, \dots, x_{ue,16}$)		HS-SCCH-1: 1010101010101010 (every third TTI only, UE under test addressed solely via HS-SCCH-1) HS-SCCH-2: 0001001010101010 HS-SCCH-3: 0001101010101010 HS-SCCH-4: 0001111101010101		
HS-DSCH TF of UE1		TF corresponding to CQI1		
HS-SCCH-1 transmission pattern		The HS-SCCH-1 shall be transmitted continuously with constant power.		
HS-PDSCH transmission pattern		The HS-PDSCH shall be transmitted continuously with constant power.		
HS-SCCH-1 TTI Signalling Pattern	-	The six sub-frame HS-SCCH-1 signalling pattern shall be "...XOOXOO...", where "X" indicates TTI in which the HS-SCCH-1 uses the identity of the UE under test, and "O" indicates TTI in which the HS-SCCH-1 uses a different UE identity.		

Table 9.4.1.2: Minimum requirement for HS-SCCH detection – single link

Test Number	Propagation Conditions	Reference value		
		HS-SCCH-1 E_c/I_{or} (dB)	\hat{I}_{or}/I_{oc} (dB)	$P(E_m)$
1	PA3	-9	0	0.05
2	PA3	-9.9	5	0.01
3	VA30	-10	0	0.01

The reference for this requirement is TS 25.101 [1] clause 9.4.1.

9.4.1.3 Test purpose

To verify that $P(E_m)$ does not exceed the limit in table 9.4.1.2.

9.4.1.4 Method of test

9.4.1.4.1 Initial conditions

Test environment: normal; see clauses G.2.1 and G.2.2.

Frequencies to be tested: mid range; see clause G.2.4.

1. Connect SS, multipath fading simulator and an AWGN noise source to the UE antenna connector as shown in figure A.10.
2. Set the test parameters for test 1-3 as specified in table 9.4.1.3 and 9.4.1.4. Setup fading simulators as fading condition, which are described in table D.2.2.1A.

9.4.1.4.2 Procedure

1. The UE is switched on.
2. Set up a HSDPA connection with looping back 12.2kbps RMC according to the generic HSDPA set-up procedure specified in TS 34.108 [3] sub clause 7.3.6 with levels according to table E.5.0.
3. Once the HSDPA connection is setup, change levels according to Table E.5.4 and start transmitting HSDPA Data.

4. Count the number of NACK, ACK and statDTX on the UL HS-DPCCH during the test interval and decide pass or fail according to Annex F.6.1 and table F.6.1.8. NACK and ACK are counted as a pass and statDTX is counted as a failure.

9.4.1.5 Test Requirements

Tables 9.4.1.3. and 9.4.1.4 define the primary level settings including test tolerance and test parameters for relevant tests. The probability of event E_m denoted as $P(E_m)$ (test procedure step 3) shall not exceed the specified value in table 9.4.1.4. The pass/fail decision is done according to Annex F.6.1.

Table 9.4.1.3: Test parameters for HS-SCCH detection – single link

Parameter	Unit	Test 1	Test 2	Test 3
I_{oc}	dBm/3.84 MHz	-60		
Phase reference	-	P-CPICH		
P-CPICH E_c/I_{or}	dB	-9.9		
HS-SCCH UE Identity ($x_{ue,1}, x_{ue,2}, \dots, x_{ue,16}$)		HS-SCCH-1: 1010101010101010 (every third TTI only, UE under test addressed solely via HS-SCCH-1) HS-SCCH-2: 0001001010101010 HS-SCCH-3: 0001101010101010 HS-SCCH-4: 0001111110101010		
HS-DSCH TF of UE1		TF corresponding to CQI1		
MAC-d PDU size	Bits	112		
HS-SCCH-1 transmission pattern		The HS-SCCH-1 shall be transmitted continuously with constant power.		
HS-PDSCH transmission pattern		The HS-PDSCH shall be transmitted continuously with constant power.		
HS-SCCH-1 TTI Signalling Pattern	-	The six sub-frame HS-SCCH-1 signalling pattern shall be "...XOOXOO...", where "X" indicates TTI in which the HS-SCCH-1 uses the identity of the UE under test, and "O" indicates TTI in which the HS-SCCH-1 uses a different UE identity.		
Number of HARQ processes		2		

Table 9.4.1.4: Test requirement for HS-SCCH detection – single link

Test Number	Propagation Conditions	Reference value		
		HS-SCCH-1 E_c/I_{or} (dB)	\hat{I}_{or}/I_{oc} (dB)	$P(E_m)$
1	PA3	-8.9	0.6	0.05
2	PA3	-9.8	5.6	0.01
3	VA30	-9.9	0.6	0.01

NOTE: If the above Test Requirement differs from the Minimum Requirement then the Test Tolerance applied for this test is non-zero. The Test Tolerance for this test is defined in clause F.2 and the explanation of how the Minimum Requirement has been relaxed by the Test Tolerance is given in clause F.4

9.4.1A Single Link Performance – Enhanced Performance Requirements Type 1

9.4.1A.1 Definition and applicability

The detection performance of the HS-SCCH is determined by the probability of event E_m , which is declared when the UE is signalled on HS-SCCH-1, but DTX is observed in the corresponding HS-DPCCH ACK/NACK field. The probability of event E_m is denoted $P(E_m)$.

The requirements and this test apply for Release 6 and later to all types of UTRA for FDD UE that support HSDPA and the optional enhanced performance requirements type 1.

9.4.1A.2 Minimum requirements

For the parameters specified in Table 9.4.1A.1, for each value of HS-SCCH-1 E_c/I_{or} specified in Table 9.4.1A.2 the measured $P(E_m)$ shall be less than or equal to the corresponding specified value of $P(E_m)$.

Table 9.4.1A.1: Test parameters for HS-SCCH detection – single link

Parameter	Unit	Test 1	Test 2	Test 3
I_{oc}	dBm/3.84 MHz		-60	
Phase reference	-		P-CPICH	
P-CPICH E_c/I_{or}	dB		-10	
HS-SCCH UE Identity ($x_{ue,1}, x_{ue,2}, \dots, x_{ue,16}$)		HS-SCCH-1: 1010101010101010 (every third TTI only, UE under test addressed solely via HS-SCCH-1) HS-SCCH-2: 0001001010101010 HS-SCCH-3: 0001101010101010 HS-SCCH-4: 0001111110101010		
HS-DSCH TF of UE1		TF corresponding to CQI1		
HS-SCCH-1 transmission pattern		The HS-SCCH-1 shall be transmitted continuously with constant power.		
HS-PDSCH transmission pattern		The HS-PDSCH shall be transmitted continuously with constant power.		
HS-SCCH-1 TTI Signalling Pattern	-	The six sub-frame HS-SCCH-1 signalling pattern shall be "...XOOXOO...", where "X" indicates TTI in which the HS-SCCH-1 uses the identity of the UE under test, and "O" indicates TTI in which the HS-SCCH-1 uses a different UE identity.		

Table 9.4.1A.2: Minimum requirement for Enhanced performance requirements type 1 for HS-SCCH detection – single link

Test Number	Propagation Conditions	Reference value		
		HS-SCCH-1 E_c/I_{or} (dB)	\hat{I}_{or}/I_{oc} (dB)	$P(E_m)$
1	PA3	-12.0	0	0.01
2	VA30	-15.6	0	0.01

The reference for this requirement is TS 25.101 [1] clause 9.4.1.

9.4.1A.3 Test purpose

To verify that $P(E_m)$ does not exceed the limit in table 9.4.1A.2.

9.4.1A.4 Method of test

9.4.1A.4.1 Initial conditions

Test environment: normal; see clauses G.2.1 and G.2.2.

Frequencies to be tested: mid range; see clause G.2.4.

1. Connect SS, multipath fading simulators and AWGN noise sources to the UE antenna connector(s) as shown in figure A.21 for UEs that support receive diversity or figure A.10 for UEs that do not support receive diversity.
2. Set the test parameters for test 1-2 as specified in table 9.4.1A.3 and 9.4.1A.4. Setup fading simulators as fading condition, which are described in table D.2.2.1A and for UEs that support receive diversity as also described in clause D.2.5.

9.4.1A.4.2 Procedure

1. The UE is switched on.

2. Set up a HSDPA connection with looping back 12.2kbps RMC according to the generic HSDPA set-up procedure specified in TS 34.108 [3] sub clause 7.3.6 with levels according to table E.5.0.
3. Once the HSDPA connection is setup, change levels according to Table E.5.4 and start transmitting HSDPA Data.
4. Count the number of NACK, ACK and statDTX on the UL HS-DPCCH during the test interval and decide pass or fail according to Annex F.6.1 and table F.6.1.8. NACK and ACK are counted as a pass and statDTX is counted as a failure.

9.4.1A.5 Test Requirements

Tables 9.4.1A.3. and 9.4.1A.4 define the primary level settings including test tolerance and test parameters for relevant tests. The probability of event E_m denoted as $P(E_m)$ (test procedure step 3) shall not exceed the specified value in table 9.4.1A.4. The pass/fail decision is done according to Annex F.6.1.

Table 9.4.1A.3: Test parameters for HS-SCCH detection – single link

Parameter	Unit	Test 1	Test 2	Test 3
I_{oc}	dBm/3.84 MHz	-60		
Phase reference	-	P-CPICH		
P-CPICH E_c/I_{or}	dB	-9.9		
HS-SCCH UE Identity ($x_{ue,1}, x_{ue,2}, \dots, x_{ue,16}$)		HS-SCCH-1: 1010101010101010 (every third TTI only, UE under test addressed solely via HS-SCCH-1) HS-SCCH-2: 0001001010101010 HS-SCCH-3: 0001101010101010 HS-SCCH-4: 0001111110101010		
HS-DSCH TF of UE1		TF corresponding to CQI1		
MAC-d PDU size	Bits	112		
HS-SCCH-1 transmission pattern		The HS-SCCH-1 shall be transmitted continuously with constant power.		
HS-PDSCH transmission pattern		The HS-PDSCH shall be transmitted continuously with constant power.		
HS-SCCH-1 TTI Signalling Pattern	-	The six sub-frame HS-SCCH-1 signalling pattern shall be "...XOOXOO...", where "X" indicates TTI in which the HS-SCCH-1 uses the identity of the UE under test, and "O" indicates TTI in which the HS-SCCH-1 uses a different UE identity.		
Number of HARQ processes		2		

Table 9.4.1A.4: Test requirement for Enhanced performance requirements type 1 for HS-SCCH detection – single link

Test Number	Propagation Conditions	Reference value		
		HS-SCCH-1 E_c/I_{or} (dB)	\hat{I}_{or}/I_{oc} (dB)	$P(E_m)$
1	PA3	-11.9	0.6	0.01
2	VA30	-15.5	0.6	0.01

NOTE: If the above Test Requirement differs from the Minimum Requirement then the Test Tolerance applied for this test is non-zero. The Test Tolerance for this test is defined in clause F.2 and the explanation of how the Minimum Requirement has been relaxed by the Test Tolerance is given in clause F.4.

9.4.2 Open Loop Diversity Performance

9.4.2.1 Definition and applicability

The detection performance of the HS-SCCH is determined by the probability of event E_m , which is declared when the UE is signalled on HS-SCCH-1, but DTX is observed in the corresponding HS-DPCCH ACK/NACK field. The probability of event E_m is denoted $P(E_m)$.

The requirements and this test apply for Release 6 and later to all types of UTRA for FDD UE that support HSDPA.

9.4.2.2 Minimum requirements

For the test parameters specified in Table 9.4.2.1, for each value of HS-SCCH-1 E_c/I_{or} specified in Table 9.4.2.2 the measured $P(E_m)$ shall be less than or equal to the corresponding specified value of $P(E_m)$.

Table 9.4.2.1: Test parameters for HS-SCCH detection – open loop diversity

Parameter	Unit	Test 1	Test 2	Test 3
I_{oc}	dBm/3.84 MHz		-60	
Phase reference	-		P-CPICH	
P-CPICH E_c/I_{or}	dB		-10	
HS-SCCH UE Identity ($x_{ue,1}, x_{ue,2}, \dots, x_{ue,16}$)		HS-SCCH-1: 1010101010101010 (every third TTI only, UE under test addressed solely via HS-SCCH-1) HS-SCCH-2: 0001001010101010 HS-SCCH-3: 0001101010101010 HS-SCCH-4: 0001111110101010		
HS-DSCH TF of UE1		TF corresponding to CQI1		
HS-SCCH-1 transmission pattern		The HS-SCCH-1 shall be transmitted continuously with constant power.		
HS-PDSCH transmission pattern		The HS-PDSCH shall be transmitted continuously with constant power.		
HS-SCCH-1 TTI Signalling Pattern	-	The six sub-frame HS-SCCH-1 signalling pattern shall be "...XOOXOO...", where "X" indicates TTI in which the HS-SCCH-1 uses the identity of the UE under test, and "O" indicates TTI in which the HS-SCCH-1 uses a different UE identity.		

Table 9.4.2.2: Minimum requirement for HS-SCCH detection – open loop diversity

Test Number	Propagation Conditions	Reference value		
		HS-SCCH-1 E_c/I_{or} (dB)	\hat{I}_{or}/I_{oc} (dB)	$P(E_m)$
1	PA3	-11.6	0	0.05
2	PA3	-13.4	5	0.01
3	VA30	-11.5	0	0.01

The reference for this requirement is TS 25.101 [1] clause 9.4.2.

9.4.2.3 Test purpose

To verify that $P(E_m)$ does not exceed the limit in table 9.4.2.2.

9.4.2.4 Method of test

9.4.2.4.1 Initial conditions

Test environment: normal; see clauses G.2.1 and G.2.2.

Frequencies to be tested: mid range; see clause G.2.4.

1. Connect SS, multipath fading simulators and AWGN noise sources to the UE antenna connector as shown in figure A.12.

- Set the test parameters for test 1-3 as specified in table 9.4.2.4 and 9.4.2.5. Setup fading simulators as fading condition, which are described in table D.2.2.1A and clause D.2.7.

9.4.2.4.2 Procedure

- The UE is switched on.
- Set up a HSDPA connection with looping back 12.2kbps RMC according to the generic HSDPA set-up procedure specified in TS 34.108 [3] sub clause 7.3.6 with the exceptions for information elements listed in table 9.4.2.3, with levels according to table E.5.0.
- Once the HSDPA connection is setup, change levels according to Table E.5.4 and start transmitting HSDPA Data.
- Count the number of NACK, ACK and statDTX on the UL HS-DPCCH during the test interval and decide pass or fail according to Annex F.6.1 and table F.6.1.8. NACK and ACK are counted as a pass and statDTX is counted as a failure.

Table 9.4.2.3: Specific Message Contents for open-loop transmit diversity mode

SYSTEM INFORMATION BLOCK TYPE5

Information Element	Value/remark
PRACH system information list - AICH info - STTD Indicator	TRUE
Secondary CCPCH system information - PICH info - STTD Indicator - Secondary CCPCH info - STTD Indicator	TRUE TRUE
Primary CCPCH info - CHOICE mode - TX Diversity indicator	FDD TRUE

SYSTEM INFORMATION BLOCK TYPE11

Information Element	Value/remark
New intra-frequency cells - Intra-frequency cell id	1
- TX Diversity indicator	TRUE

RRC CONNECTION SETUP

Information Element	Value/remark
Downlink information common for all radio links - CHOICE mode - TX Diversity Mode	FDD STTD
Downlink DPCH info for each RL - CHOICE mode - Downlink DPCH info for each RL - Closed loop timing adjustment mode	FDD 1

RADIO BEARER SETUP for Closed test loop mode1 and HSDPA

Information Element	Value/remark
Downlink information common for all radio links - CHOICE mode - TX Diversity Mode	FDD STTD
Downlink DPCH info for each RL - CHOICE mode - Downlink DPCH info for each RL - Closed loop timing adjustment mode	FDD 1

9.4.2.5 Test Requirements

Tables 9.4.2.4. and 9.4.2.5 define the primary level settings including test tolerance and test parameters for relevant tests. The probability of event E_m denoted as $P(E_m)$ (test procedure step 3) shall not exceed the specified value in table 9.4.2.5. The pass/fail decision is done according to Annex F.6.1.

Table 9.4.2.4: Test parameters for HS-SCCH detection – open loop diversity

Parameter	Unit	Test 1	Test 2	Test 3
I_{oc}	dBm/3.84 MHz		-60	
Phase reference	-		P-CPICH	
P-CPICH E_c/I_{or}	dB		-9.9	
HS-SCCH UE Identity ($x_{ue,1}, x_{ue,2}, \dots, x_{ue,16}$)		HS-SCCH-1: 1010101010101010 (every third TTI only, UE under test addressed solely via HS-SCCH-1) HS-SCCH-2: 0001001010101010 HS-SCCH-3: 0001101010101010 HS-SCCH-4: 0001111110101010		
HS-DSCH TF of UE1		TF corresponding to CQI1		
MAC-d PDU size	Bits	112		
HS-SCCH-1 transmission pattern		The HS-SCCH-1 shall be transmitted continuously with constant power.		
HS-PDSCH transmission pattern		The HS-PDSCH shall be transmitted continuously with constant power.		
HS-SCCH-1 TTI Signalling Pattern	-	The six sub-frame HS-SCCH-1 signalling pattern shall be "...XOOXOO...", where "X" indicates TTI in which the HS-SCCH-1 uses the identity of the UE under test, and "O" indicates TTI in which the HS-SCCH-1 uses a different UE identity.		
Number of HARQ processes		2		

Table 9.4.2.5: Test requirement for HS-SCCH detection – open loop diversity

Test Number	Propagation Conditions	Reference value		
		HS-SCCH-1 E_c/I_{or} (dB)	\hat{I}_{or}/I_{oc} (dB)	$P(E_m)$
1	PA3	-11.5	0.8	0.05
2	PA3	-13.3	5.8	0.01
3	VA30	-11.4	0.8	0.01

NOTE: If the above Test Requirement differs from the Minimum Requirement then the Test Tolerance applied for this test is non-zero. The Test Tolerance for this test is defined in clause F.2 and the explanation of how the Minimum Requirement has been relaxed by the Test Tolerance is given in clause F.4.

9.4.2A Open Loop Diversity Performance - Enhanced Performance Requirements Type 1

9.4.2A.1 Definition and applicability

The detection performance of the HS-SCCH is determined by the probability of event E_m , which is declared when the UE is signalled on HS-SCCH-1, but DTX is observed in the corresponding HS-DPCCH ACK/NACK field. The probability of event E_m is denoted $P(E_m)$.

The requirements and this test apply for Release 6 and later to all types of UTRA for FDD UE that support HSDPA and the optional enhanced performance requirements type 1.

9.4.2A.2 Minimum requirements

For the test parameters specified in Table 9.4.2A.1, for each value of HS-SCCH-1 E_c/I_{or} specified in Table 9.4.2A.2 the measured $P(E_m)$ shall be less than or equal to the corresponding specified value of $P(E_m)$.

Table 9.4.2A.1: Test parameters for HS-SCCH detection – open loop diversity

Parameter	Unit	Test 1	Test 2	Test 3
I_{oc}	dBm/3.84 MHz		-60	
Phase reference	-		P-CPICH	
P-CPICH E_c/I_{or}	dB		-10	
HS-SCCH UE Identity ($x_{ue,1}, x_{ue,2}, \dots, x_{ue,16}$)			HS-SCCH-1: 1010101010101010 (every third TTI only, UE under test addressed solely via HS-SCCH-1) HS-SCCH-2: 0001001010101010 HS-SCCH-3: 0001101010101010 HS-SCCH-4: 00011111010101010	
HS-DSCH TF of UE1			TF corresponding to CQI1	
HS-SCCH-1 transmission pattern			The HS-SCCH-1 shall be transmitted continuously with constant power.	
HS-PDSCH transmission pattern			The HS-PDSCH shall be transmitted continuously with constant power.	
HS-SCCH-1 TTI Signalling Pattern	-		The six sub-frame HS-SCCH-1 signalling pattern shall be "...XOOXOO...", where "X" indicates TTI in which the HS-SCCH-1 uses the identity of the UE under test, and "O" indicates TTI in which the HS-SCCH-1 uses a different UE identity.	

Table 9.4.2A.2: Minimum requirement for Enhanced performance requirements type 1 for HS-SCCH detection – open loop diversity

Test Number	Propagation Conditions	Reference value		
		HS-SCCH-1 E_c/I_{or} (dB)	\hat{I}_{or}/I_{oc} (dB)	$P(E_m)$
1	PA3	-15.2	0	0.01
2	VA30	-16.4	0	0.01

The reference for this requirement is TS 25.101 [1] clause 9.4.2.

9.4.2A.3 Test purpose

To verify that $P(E_m)$ does not exceed the limit in table 9.4.2A.2.

9.4.2A.4 Method of test

9.4.2A.4.1 Initial conditions

Test environment: normal; see clauses G.2.1 and G.2.2.

Frequencies to be tested: mid range; see clause G.2.4.

1. Connect SS, multipath fading simulator and an AWGN noise source to the UE antenna connector as shown in figure A.22 for UEs that support receive diversity or figure A.12 for UEs that do not support receive diversity.
2. Set the test parameters for test 1-2 as specified in table 9.4.2A.4 and 9.4.2A.5. Setup fading simulators as fading condition, which are described in table D.2.2.1A and clause D.2.5. The configuration of the downlink channels is defined in table E.5.4.

9.4.2A.4.2 Procedure

1. The UE is switched on.
2. Set up a HSDPA connection with looping back 12.2kbps RMC according to the generic HSDPA set-up procedure specified in TS 34.108 [3] sub clause 7.3.6 with the exceptions for information elements listed in table 9.4.2A.3, with levels according to table E.5.0.
3. Once the HSDPA connection is setup, change levels according to Table E.5.4 and start transmitting HSDPA Data.

4. Count the number of NACK, ACK and statDTX on the UL HS-DPCCH during the test interval and decide pass or fail according to Annex F.6.1 and table F.6.1.8. NACK and ACK are counted as a pass and statDTX is counted as a failure.

Table 9.4.2A.3: Specific Message Contents for open-loop transmit diversity mode

SYSTEM INFORMATION BLOCK TYPE5

Information Element	Value/remark
PRACH system information list - AICH info - STTD Indicator	TRUE
Secondary CCPCH system information - PICH info - STTD Indicator - Secondary CCPCH info - STTD Indicator	TRUE TRUE
Primary CCPCH info - CHOICE mode - TX Diversity indicator	FDD TRUE

SYSTEM INFORMATION BLOCK TYPE11

Information Element	Value/remark
New intra-frequency cells - Intra-frequency cell id	1
- TX Diversity indicator	TRUE

RRC CONNECTION SETUP

Information Element	Value/remark
Downlink information common for all radio links - CHOICE mode - TX Diversity Mode	FDD STTD
Downlink DPCH info for each RL - CHOICE mode - Downlink DPCH info for each RL - Closed loop timing adjustment mode	FDD 1

RADIO BEARER SETUP for Closed test loop mode1 and HSDPA

Information Element	Value/remark
Downlink information common for all radio links - CHOICE mode - TX Diversity Mode	FDD STTD
Downlink DPCH info for each RL - CHOICE mode - Downlink DPCH info for each RL - Closed loop timing adjustment mode	FDD 1

9.4.2A.5 Test Requirements

Tables 9.4.2A.4. and 9.4.2A.5 define the primary level settings including test tolerance and test parameters for relevant tests. The probability of event E_m denoted as $P(E_m)$ (test procedure step 3) shall not exceed the specified value in table 9.4.2A.5. The pass/fail decision is done according to Annex F.6.1.

Table 9.4.2A.4: Test parameters for HS-SCCH detection – open loop diversity

Parameter	Unit	Test 1	Test 2	Test 3
I_{oc}	dBm/3.84 MHz		-60	
Phase reference	-		P-CPICH	
P-CPICH E_c / I_{or}	dB		-9.9	
HS-SCCH UE Identity ($x_{ue,1}, x_{ue,2}, \dots, x_{ue,16}$)		HS-SCCH-1: 1010101010101010 (every third TTI only, UE under test addressed solely via HS-SCCH-1) HS-SCCH-2: 0001001010101010 HS-SCCH-3: 0001101010101010 HS-SCCH-4: 0001111110101010		
HS-DSCH TF of UE1		TF corresponding to CQI1		
MAC-d PDU size	Bits	112		
HS-SCCH-1 transmission pattern		The HS-SCCH-1 shall be transmitted continuously with constant power.		
HS-PDSCH transmission pattern		The HS-PDSCH shall be transmitted continuously with constant power.		
HS-SCCH-1 TTI Signalling Pattern	-	The six sub-frame HS-SCCH-1 signalling pattern shall be "...XOOXOO...", where "X" indicates TTI in which the HS-SCCH-1 uses the identity of the UE under test, and "O" indicates TTI in which the HS-SCCH-1 uses a different UE identity.		
Number of HARQ processes		2		

Table 9.4.2A.5: Test requirement for Enhanced performance requirements type 1 for HS-SCCH detection – open loop diversity

Test Number	Propagation Conditions	Reference value		
		HS-SCCH-1 E_c / I_{or} (dB)	\hat{I}_{or} / I_{oc} (dB)	$P(E_m)$
1	PA3	-15.1	0.8	0.01
2	VA30	-16.3	0.8	0.01

NOTE: If the above Test Requirement differs from the Minimum Requirement then the Test Tolerance applied for this test is non-zero. The Test Tolerance for this test is defined in clause F.2 and the explanation of how the Minimum Requirement has been relaxed by the Test Tolerance is given in clause F.4.

10 Performance requirement (E-DCH)

10.1 General

The performance requirements for the UE in this subclause are specified for the propagation conditions specified in Annex D.2 and the Downlink Physical channels specified in Annex E.5A.

Unless otherwise stated the performance requirements are specified at the antenna connector of the UE. For UE(s) with more than one receive antenna connector the fading of the signals and the AWGN signals applied to each receiver antenna connector shall be uncorrelated. The levels of the test signal applied to each of the antenna connectors shall be as defined in the respective sections below. Enhanced performance requirements Type 1 are based on receiver diversity.

A UE with one antenna connector may also fulfill the enhanced performance requirements Type 1. The levels of the test signal are applied to the single antenna connector as defined in the respective sections below.

When DCCH has been configured on downlink DCH then DCCH Data shall be continuously transmitted on downlink DCH during the measurement period. When there is no signalling to transmit on downlink DCCH then dummy DCCH transmission as described in Annex C.9 shall be used.

When DTCH has been configured on downlink DCH then DTCH Data shall be continuously transmitted on downlink DCH during the measurement period.

The MAC header transmission on HS-DSCH for all E-DCH test cases shall use a correct MAC-hs header consistent with the actual HSDPA transmission.

The DL and UL RLC SDU size for all E-DCH tests in clause 10 shall be set according to Annex C.11.3.

Unless otherwise stated, the UE output power for the tests shall be greater than -10dBm.

Note: If tests are performed with maximum UE output power it is known that this may cause a good UE to fail at least for tests in section 10.4.

For Release 7 and later UEs that support the optional Type 1 enhanced performance requirements the UE shall be tested according to this enhanced performance requirement as well.

10.2 Detection of E-DCH HARQ ACK Indicator Channel (E-HICH)

10.2.1 Single link performance

10.2.1.1 Single link performance (10ms TTI)

10.2.1.1.1 Definition and applicability

The receive characteristics of the E-DCH HARQ ACK Indicator Channel (E-HICH) in different multi-path fading environments are determined by the missed ACK and false ACK values. The requirements and this test apply to Release 6 and later releases for all types of UTRA for the FDD UE that support E-DCH and HSDPA.

10.2.1.1.2 Minimum requirement

For the parameters specified in Table 10.2.1.1.2.1 the average downlink E-HICH E_c/I_{or} power ratio shall be below the specified value for the missed ACK probabilities in Table 10.2.1.1.2.2. For the parameters specified in Table 10.2.1.1.2.1 the false ACK probability shall be below the specified value in Table 10.2.1.1.2.3.

Table 10.2.1.1.2.1: Parameters for E-HICH – Serving E-DCH cell

Parameter	Unit	Missed ACK	False ACK
I_{oc}	dBm/3.84 MHz	-60	
Phase reference	-	P-CPICH	
P-CPICH E_c/I_{or}	dB	-10	
E-HICH signalling pattern	-	100% ACK	100% DTX

Table 10.2.1.1.2.2: Minimum requirement for Missed ACK when hybrid ARQ acknowledgement indicator is transmitted using 12 consecutive slots – Serving E-DCH cell

Test Number	Propagation Conditions	Reference value		
		E-HICH E_c/I_{or} (dB)	\hat{I}_{or}/I_{oc} (dB)	Missed ACK probability
1	VA30	-35.1	0	0.01

Table 10.2.1.1.2.3: Minimum requirement for False ACK when hybrid ARQ acknowledgement indicator is transmitted using 12 consecutive slots – single link

Test Number	Propagation Conditions	Reference value	
		\hat{I}_{or}/I_{oc} (dB)	False ACK probability
2	VA30	0	0.5

The reference for this requirement is TS 25.101 [1] clause 10.2.1

10.2.1.1.3 Test purpose

To verify that the average probability for missed ACK and false ACK when E-HICH is transmitted using 12 consecutive slots do not exceed the specified values.

10.2.1.1.4 Method of test

10.2.1.1.4.1 Initial conditions

Test environment: normal; see clauses G.2.1 and G.2.2.

Frequencies to be tested: mid range; see clause G.2.4.

- 1) Connect the SS and AWGN noise source and fading simulator to the UE antenna connector as shown in figure Figure A.10.
- 2) Set the test parameters for the missed ACK test and the false ACK test as specified in table 10.2.1.1.5.1.to 10.2.1.1.5.3 and table E.5A.2.
- 3) The UL Reference Measurement Channel parameters are defined in Annex C.11
- 4) The value of Absolute Grant Scope shall be set to 0, and the Absolute Grant shall be set to 5.
- 5) The relative grant is not configured. This ensures that the UL datarate remains constant.
- 6) The UE is switched on.
- 7) Enter the UE into loopback mode 1, looping back both the 12.2kbps RMC and HSDPA to E-DCH, and start the loopback test. See TS 34.108 [3] clause 7.3.9 and TS 34.109 [4] clauses 5.3.2.3 and 5.3.2.6. To fill the RLC transmit buffer, run the loopback for [3]s before starting the procedure.
- 8) Switch on the fading simulator.

10.2.1.1.4.2 Procedure

Note: The measurement principle for the missed ACK test (step 2 to 5) and for the false ACK test (step 6 to 9) is as follows. Upon the UE transmission on E-DPCCH and E-DPDCH, the SS reacts with E-HICH = ACK or DTX. The UE transmits new data or retransmissions on the corresponding E-DPCCH and E-DPDCH. The SS shall discriminate between:

(1) new data is a sign for ACK, received by the UE

(2) retransmission is a sign for NACK or DTX, received by the UE. The later is interpreted as NACK by higher layer and causes retransmission.

1. The Nominal Avg. Information Bit Rate in the DL is set to 534 kbps according to QPSK H-Set 1. The expected throughput under this level and fading conditions is 142 kbps. The UL datarate was configured by signalling AG value = 5 on the E-AGCH. The expected UL datarate is 71.6 kbps corresponding to E-TFC Index 45.
2. In the test Missed ACK the SS responds with 100% ACK.
3. If the UE indicates on the E-DPCCH a retransmission, the ACK from the SS was received as NACK or DTX by the UE. This is counted as missed(ACK).

If the UE indicates on the E-DPCCH new data, the ACK from the SS was received as ACK by the UE. This is counted as correct ACK.
4. Continue until statistical significance according to Annex F.6.4 is achieved.
5. If the number of retransmissions reaches the maximum number of retransmissions due to several false or missed ACK detections in series, the first new data on the E-DPDCH with E-DPCCH are not the consequence of ACK. This case is not counted as sample.
6. In the test false ACK the SS responds with 100% DTX.
7. If the UE indicates on the E-DPCCH new data, the DTX from the SS was received as ACK by the UE. This is counted as false(ACK). If the UE indicates on E-DPCCH retransmission, the DTX from the SS was received as DTX or NACK by the UE. This is counted as correct reception.
8. Continue until statistical significance according to Annex F.6.4 is achieved.
9. The number of retransmissions will reach the maximum number of transmissions due to several retransmissions in series. The first new data on the E-DPDCH with E-DPCCH are not the consequence of ACK received by the UE. This case is not counted as sample.

Specific Message Contents

All messages indicated above shall use the same content as described in the default message content in clause 9.2.1 of 34.108 [3] with the following exceptions:

RADIO BEARER SETUP:

Information Element	Value/remark
RLC PDU size	112
- E-DCH Transmission Time	10 ms
E-DCH MAC-d flow maximum number of retransmissions	15 (max)
E-DCH info	
- Happy bit delay condition	10 ms (indication of exhausted resources on frame basis)

10.2.1.1.5. Test requirements

Table 10.2.1.1.5.1: Test Parameters for E-HICH – Serving E-DCH cell

Parameter	Unit	Missed ACK	False ACK
I_{oc}	dBm/3.84 MHz	-60	
Phase reference	-	P-CPICH	
E-HICH E_c/I_{or}	dB	--35 (test1)	$-\infty$ (test 2)
E-HICH signalling pattern	-	100% ACK	100% DTX

Table 10.2.1.1.5.2: Test requirement for Missed ACK when hybrid ARQ acknowledgement indicator is transmitted using 12 consecutive slots – Serving E-DCH cell

Test Number	Propagation Conditions	Reference value		
		E-HICH E_c/I_{or} (dB)	\hat{I}_{or}/I_{oc} (dB)	Missed ACK probability
1	VA30	-35.0	0.6	0.01

Table 10.2.1.1.5.3: Test requirement for False ACK when hybrid ARQ acknowledgement indicator is transmitted using 12 consecutive slots – single link

Test Number	Propagation Conditions	Reference value	
		\hat{I}_{or}/I_{oc} (dB)	False ACK probability
2	VA30	0.6	0.5

To pass the test,

the ratio (missed(ACK) / all valid ACKs, sent) \leq 0.01 and
the ratio (false(ACK) / (all valid DTX, sent)) \leq 0.5

NOTE: If the above Test Requirement differs from the Minimum Requirement then the Test Tolerance applied for this test is non-zero. The Test Tolerance for this test is defined in clause F.2 and the explanation of how the Minimum Requirement has been relaxed by the Test Tolerance is given in clause F.4.

10.2.1.1A Single link performance (10ms TTI, Type 1)

10.2.1.1A.1 Definition and applicability

The receive characteristics of the E-DCH HARQ ACK Indicator Channel (E-HICH) in different multi-path fading environments are determined by the missed ACK values. The requirements and this test apply to Release 7 and later releases for all types of UTRA FDD UEs that support E-DCH and HSDPA and the optional Type 1 enhanced performance requirements.

10.2.1.1A.2 Minimum requirement

For the parameters specified in Table 10.2.1.1A.2.1 the average downlink E-HICH E_c/I_{or} power ratio shall be below the specified value for the missed ACK probabilities in Table 10.2.1.1A.2.2

Table 10.2.1.1A.2.1: Parameters for E-HICH – Serving E-DCH cell

Parameter	Unit	Missed ACK
I_{oc}	dBm/3.84 MHz	-60
Phase reference	-	P-CPICH
P-CPICH E_c/I_{or}	dB	-10
E-HICH signalling pattern	-	100% ACK

Table 10.2.1.1A.2.2: Enhanced performance requirement Type 1 for Missed ACK when hybrid ARQ acknowledgement indicator is transmitted using 12 consecutive slots – Serving E-DCH cell

Test Number	Propagation Conditions	Reference value		
		E-HICH E_c / I_{or} (dB)	\hat{I}_{or} / I_{oc} (dB)	Missed ACK probability
1	VA30	-38.3	0	0.01

The reference for this requirement is TS 25.101 [1] clause 10.2.1

10.2.1.1A.3 Test purpose

To verify that the average probability for missed ACK when E-HICH is transmitted using 12 consecutive slots do not exceed the specified values.

10.2.1.1A.4 Method of test

10.2.1.1A.4.1 Initial conditions

Test environment: normal; see clauses G.2.1 and G.2.2.

Frequencies to be tested: mid range; see clause G.2.4.

- 1) Connect the SS and AWGN noise source and fading simulator to the UE antenna connectors as shown in figure Figure A.21 for UEs that support receive diversity or figure A.10 for UEs that do not support receive diversity.
- 2) Set the test parameters for the missed ACK test as specified in table 10.2.1.1A.5.1 and 10.2.1.1A.5.3 and table E.5A.2.
- 3) The UL Reference Measurement Channel parameters are defined in Annex C.11
- 4) The value of Absolute Grant Scope shall be set to 0, and the Absolute Grant shall be set to 5.
- 5) The relative grant is not configured. This ensures that the UL datarate remains constant.
- 6) The UE is switched on.
- 7) Enter the UE into loopback mode 1, looping back both the 12.2kbps RMC and HSDPA to E-DCH, and start the loopback test. See TS 34.108 [3] clause 7.3.9 and TS 34.109 [4] clauses 5.3.2.3 and 5.3.2.6. To fill the RLC transmit buffer, run the loopback for [3]s before starting the procedure.
- 8) Switch on the fading simulators.

10.2.1.1A.4.2 Procedure

Note: The measurement principle for the missed ACK test (step 2 to 5) is as follows. Upon the UE transmission on E-DPCCH and E-DPDCH, the SS reacts with E-HICH = ACK. The UE transmits new data or retransmissions on the corresponding E-DPCCH and E-DPDCH. The SS shall discriminate between:

- (1) new data is a sign for ACK, received by the UE
- (2) retransmission is a sign for NACK or DTX, received by the UE. The later is interpreted as NACK by higher layer and causes retransmission.

1. The Nominal Avg. Information Bit Rate in the DL is set to 534 kbps according to QPSK H-Set 1. The expected throughput under this level and fading conditions is 142 kbps. The UL datarate was configured by signalling AG value = 5 on the E-AGCH. The expected UL datarate is 71.6 kbps corresponding to E-TFC Index 45.
2. In the test Missed ACK the SS responds with 100% ACK.
3. If the UE indicates on the E-DPCCH a retransmission, the ACK from the SS was received as NACK or DTX by the UE. This is counted as missed(ACK).

If the UE indicates on the E-DPCCH new data, the ACK from the SS was received as ACK by the UE. This is counted as correct ACK.

4. Continue until statistical significance according to Annex F.6.4 is achieved.
5. If the number of retransmissions reaches the maximum number of retransmissions due to several false or missed ACK detections in series, the first new data on the E-DPDCH with E-DPCCH are not the consequence of ACK. This case is not counted as sample.

Specific Message Contents

All messages indicated above shall use the same content as described in the default message content in clause 9.2.1 of 34.108 [3] with the following exceptions:

RADIO BEARER SETUP:

Information Element	Value/remark
RLC PDU size	112
- E-DCH Transmission Time	10 ms
E-DCH MAC-d flow maximum number of retransmissions	15 (max)
E-DCH info	
- Happy bit delay condition	10 ms (indication of exhausted resources on frame basis)

10.2.1.1A.5. Test requirements

Table 10.2.1.1A.5.1: Test Parameters for E-HICH – Serving E-DCH cell

Parameter	Unit	Missed ACK
I_{oc}	dBm/3.84 MHz	-60
Phase reference	-	P-CPICH
E-HICH E_c/I_{or}	dB	-38.2(test1)
E-HICH signalling pattern	-	100% ACK

Table 10.2.1.1A.5.2: Test requirement Type 1 for Missed ACK when hybrid ARQ acknowledgement indicator is transmitted using 12 consecutive slots – Serving E-DCH cell

Test Number	Propagation Conditions	Reference value		
		E-HICH E_c/I_{or} (dB)	\hat{I}_{or}/I_{oc} (dB)	Missed ACK probability
1	VA30	-38.2	0.6	0.01

To pass the test,

the ratio (missed(ACK) / all valid ACKs, sent) ≤ 0.01

NOTE: If the above Test Requirement differs from the Minimum Requirement then the Test Tolerance applied for this test is non-zero. The Test Tolerance for this test is defined in clause F.2 and the explanation of how the Minimum Requirement has been relaxed by the Test Tolerance is given in clause F.4.

10.2.1.2 Single link performance (2ms TTI)

10.2.1.2.1 Definition and applicability

The receive characteristics of the E-DCH HARQ ACK Indicator Channel (E-HICH) in different multi-path fading environments are determined by the missed ACK and false ACK values. The requirements and this test apply to Release 6 and later releases for all types of UTRA for the FDD UE that support E-DCH with 2ms TTI and HSDPA.

10.2.1.2.2 Minimum requirement

For the parameters specified in Table 10.2.1.2.2.1 the average downlink E-HICH E_c/I_{or} power ratio shall be below the specified value for the missed ACK probabilities in Table 10.2.1.2.2.2 For the parameters specified in Table 10.2.1.2.2.1 the false ACK probability shall be below the specified value in Table 10.2.1.2.2.3.

Table 10.2.1.2.2.1: Parameters for E-HICH – Serving E-DCH cell

Parameter	Unit	Missed ACK	False ACK
I_{oc}	dBm/3.84 MHz	-60	
Phase reference	-	P-CPICH	
P-CPICH E_c/I_{or}	dB	-10	
E-HICH signalling pattern	-	100% ACK	100% DTX

Table 10.2.1.2.2.2: Minimum requirement for Missed ACK when hybrid ARQ acknowledgement indicator is transmitted using 3 consecutive slots – Serving E-DCH cell

Test Number	Propagation Conditions	Reference value		
		E-HICH E_c/I_{or} (dB)	\hat{I}_{or}/I_{oc} (dB)	Missed ACK probability
1	VA30	-28.3	0	0.01

Table 10.2.1.2.2.3: Minimum requirement for False ACK when hybrid ARQ acknowledgement indicator is transmitted using 3 consecutive slots – Serving E-DCH cell

Test Number	Propagation Conditions	Reference value	
		\hat{I}_{or}/I_{oc} (dB)	False ACK probability
2	VA30	0	0.5

The reference for this requirement is TS 25.101 [1] clause 10.2.1

10.2.1.2.3 Test purpose

To verify that the average probability for missed ACK and false ACK, when E-HICH is transmitted using 3 consecutive slots, do not exceed the specified values.

10.2.1.2.4 Method of test

10.2.1.2.4.1 Initial conditions

Test environment: normal; see clauses G.2.1 and G.2.2.

Frequencies to be tested: mid range; see clause G.2.4.

- 1) Connect the SS and AWGN noise source and fading simulator to the UE antenna connector as shown in figure Figure A.10.
- 2) Set the test parameters for the missed ACK test and the false ACK test as specified in table 10.2.1.2.5.1.to 10.2.1.2.5.3 and table E.5A.2.
- 3) The UL Reference Measurement Channel parameters are defined in Annex C.11
- 4) The value of Absolute Grant Scope shall be set to the 0 and the Absolute Grant shall be set to 4.
- 5) The relative grant is not configured. This ensures that the UL datarate remains constant.
- 6) The UE is switched on.
- 7) Enter the UE into loopback mode 1, looping back both the 12.2kbps RMC and HSDPA to E-DCH, and start the loopback test. See TS 34.108 [3] clause 7.3.9 and TS 34.109 [4] clauses 5.3.2.3 and 5.3.2.6. To fill the RLC transmit buffer, run the loopback for [3]s before starting the procedure.
- 8) Switch on the fading simulator.

10.2.1.2.4.2 Procedure

Note: The measurement principle for the missed ACK test (step 2 to 5) and for the false ACK test (step 6 to 9) is as follows. Upon the UE transmission on E-DPCCH and E-DPDCH, the SS reacts with E-HICH = ACK or DTX. The UE transmits new data or retransmissions on the corresponding E-DPCCH and E-DPDCH. The SS shall discriminate between:

(1) new data is a sign for ACK, received by the UE

(2) retransmission is a sign for NACK or DTX, received by the UE. The later is interpreted as NACK by higher layer and causes retransmission.

1. The Nominal Avg. Information Bit Rate in the DL is set to 534 kbps according to QPSK H-Set 1. The expected throughput under this level and fading conditions is 142 kbps. The UL data rate was configured by signalling AG value 4 on the E-AGCH. The expected UL datarate is 273 kbps corresponding to E-TFC Index 39.
2. In the test Missed ACK the SS responds with 100% ACK.
3. If the UE indicates on the E-DPCCH a retransmission, the ACK from the SS was received as NACK or DTX by the UE. This is counted as missed(ACK).

If the UE indicates on the E-DPCCH new data, the ACK from the SS was received as ACK by the UE. This is counted as correct ACK.
4. Continue until statistical significance according to Annex F.6.4 is achieved.
5. If the number of retransmissions reaches the maximum number of retransmissions due to several false or missed ACK detections in series, the first new data on the E-DPDCH with E-DPCCH are not the consequence of ACK. This case is not counted as sample.
6. In the test False ACK the SS responds with 100% DTX.
7. If the UE indicates on the E-DPCCH new data, the DTX from the SS was received as ACK by the UE. This is counted as false(ACK). If the UE indicates on E-DPCCH retransmission, the DTX from the SS was received as DTX or NACK by the UE. This is counted as correct reception.
8. Continue until statistical significance according to Annex F.6.4 is achieved.
9. The number of retransmissions will reach the maximum number of transmissions due to several retransmissions in series. The first new data on the E-DPDCH with E-DPCCH are not the consequence of ACK received by the UE. This case is not counted as sample.

Specific Message Contents

All messages indicated above shall use the same content as described in the default message content in clause 9.2.1 of 34.108 [3] with the following exceptions:

RADIO BEARER SETUP:

Information Element	Value/remark
RLC PDU size	112
- E-DCH Transmission Time	2ms
E-DCH MAC-d flow maximum number of retransmissions	15 (max)
E-DCH info	
- Happy bit delay condition	2ms (indication of exhausted resources on TTI basis)

10.2.1.2.5. Test requirements

Table 10.2.1.2.5.1: Test Parameters for E-HICH – Serving E-DCH cell

Parameter	Unit	Missed ACK	False ACK
I_{oc}	dBm/3.84 MHz	-60	
Phase reference	-	P-CPICH	
E-HICH E_c/I_{or}	dB	-28.2 (test 1)	$-\infty$ (test 2)
E-HICH signalling pattern	-	100% ACK	100% DTX

Table 10.2.1.2.5.2: Test requirement for Missed ACK when hybrid ARQ acknowledgement indicator is transmitted using 3 consecutive slots – Serving E-DCH cell

Test Number	Propagation Conditions	Reference value		
		E-HICH E_c/I_{or} (dB)	\hat{I}_{or}/I_{oc} (dB)	Missed ACK probability
1	VA30	-28.2	0.6	0.01

Table 10.2.1.2.5.3: Test requirement for False ACK when hybrid ARQ acknowledgement indicator is transmitted using 3 consecutive slots – Serving E-DCH cell

Test Number	Propagation Conditions	Reference value	
		\hat{I}_{or}/I_{oc} (dB)	False ACK probability
2	VA30	0.6	0.5

To pass the test,

the ratio (missed(ACK) / all valid ACKs, sent) ≤ 0.01 and
the ratio (false(ACK) / (all valid DTX, sent)) ≤ 0.5

NOTE: If the above Test Requirement differs from the Minimum Requirement then the Test Tolerance applied for this test is non-zero. The Test Tolerance for this test is defined in clause F.2 and the explanation of how the Minimum Requirement has been relaxed by the Test Tolerance is given in clause F.4.

10.2.1.2A Single link performance (2ms TTI, Type 1)

10.2.1.2A.1 Definition and applicability

The receive characteristics of the E-DCH HARQ ACK Indicator Channel (E-HICH) in different multi-path fading environments are determined by the missed ACK values. The requirements and this test apply to Release 7 and later releases for all types of UTRA FDD UEs that support E-DCH with 2ms TTI and HSDPA and the optional Type 1 enhanced performance requirements.

10.2.1.2A.2 Minimum requirement

For the parameters specified in Table 10.2.1.2A.2.1 the average downlink E-HICH E_c/I_{or} power ratio shall be below the specified value for the missed ACK probabilities in Table 10.2.1.2A.2.2

Table 10.2.1.2A.2.1: Parameters for E-HICH – Serving E-DCH cell

Parameter	Unit	Missed ACK
I_{oc}	dBm/3.84 MHz	-60
Phase reference	-	P-CPICH
P-CPICH E_c/I_{or}	dB	-10
E-HICH signalling pattern	-	100% ACK

Table 10.2.1.2A.2.2: Enhanced performance requirement Type 1 for Missed ACK when hybrid ARQ acknowledgement indicator is transmitted using 3 consecutive slots – Serving E-DCH cell

Test Number	Propagation Conditions	Reference value		
		E-HICH E_c / I_{or} (dB)	\hat{I}_{or} / I_{oc} (dB)	Missed ACK probability
1	VA30	-31.7	0	0.01

The reference for this requirement is TS 25.101 [1] clause 10.2.1

10.2.1.2A.3 Test purpose

To verify that the average probability for missed ACK, when E-HICH is transmitted using 3 consecutive slots, do not exceed the specified values.

10.2.1.2A.4 Method of test

10.2.1.2A.4.1 Initial conditions

Test environment: normal; see clauses G.2.1 and G.2.2.

Frequencies to be tested: mid range; see clause G.2.4.

- 1) Connect the SS and AWGN noise source and fading simulator to the UE antenna connector as shown in figure Figure A.21 for UEs that support receive diversity or figure A.10 for UEs that do not support receive diversity.
- 2) Set the test parameters for the missed ACK test as specified in table 10.2.1.2A.5.1 and 10.2.1.2A.5.2 and table E.5A.2.
- 3) The UL Reference Measurement Channel parameters are defined in Annex C.11
- 4) The value of Absolute Grant Scope shall be set to the 0 and the Absolute Grant shall be set to 4.
- 5) The relative grant is not configured. This ensures that the UL datarate remains constant.
- 6) The UE is switched on.
- 7) Enter the UE into loopback mode 1, looping back both the 12.2kbps RMC and HSDPA to E-DCH, and start the loopback test. See TS 34.108 [3] clause 7.3.9 and TS 34.109 [4] clauses 5.3.2.3 and 5.3.2.6. To fill the RLC transmit buffer, run the loopback for [3]s before starting the procedure.
- 8) Switch on the fading simulator.

10.2.1.2A.4.2 Procedure

Note: The measurement principle for the missed ACK test (step 2 to 5) is as follows. Upon the UE transmission on E-DPCCH and E-DPDCH, the SS reacts with E-HICH = ACK. The UE transmits new data or retransmissions on the corresponding E-DPCCH and E-DPDCH. The SS shall discriminate between:

- (1) new data is a sign for ACK, received by the UE
- (2) retransmission is a sign for NACK or DTX, received by the UE. The later is interpreted as NACK by higher layer and causes retransmission.

1. The Nominal Avg. Information Bit Rate in the DL is set to 534 kbps according to QPSK H-Set 1. The expected throughput under this level and fading conditions is 142 kbps. The UL data rate was configured by signalling AG value 4 on the E-AGCH. The expected UL datarate is 273 kbps corresponding to E-TFC Index 39.
2. In the test Missed ACK the SS responds with 100% ACK.
3. If the UE indicates on the E-DPCCH a retransmission, the ACK from the SS was received as NACK or DTX by the UE. This is counted as missed(ACK).

If the UE indicates on the E-DPCCH new data, the ACK from the SS was received as ACK by the UE. This is counted as correct ACK.

4. Continue until statistical significance according to Annex F.6.4 is achieved.
5. If the number of retransmissions reaches the maximum number of retransmissions due to several false or missed ACK detections in series, the first new data on the E-DPDCH with E-DPCCH are not the consequence of ACK. This case is not counted as sample.

Specific Message Contents

All messages indicated above shall use the same content as described in the default message content in clause 9.2.1 of 34.108 [3] with the following exceptions:

RADIO BEARER SETUP:

Information Element	Value/remark
RLC PDU size	112
- E-DCH Transmission Time	2ms
E-DCH MAC-d flow maximum number of retransmissions	15 (max)
E-DCH info	
- Happy bit delay condition	2ms (indication of exhausted resources on TTI basis)

10.2.1.2A.5. Test requirements

Table 10.2.1.2A.5.1: Test Parameters for E-HICH – Serving E-DCH cell

Parameter	Unit	Missed ACK
I_{oc}	dBm/3.84 MHz	-60
Phase reference	-	P-CPICH
E-HICH E_c/I_{or}	dB	-31.6 (test 1)
E-HICH signalling pattern	-	100% ACK

Table 10.2.1.2A.5.2: Test requirement Type 1 for Missed ACK when hybrid ARQ acknowledgement indicator is transmitted using 3 consecutive slots – Serving E-DCH cell

Test Number	Propagation Conditions	Reference value		
		E-HICH E_c/I_{or} (dB)	\hat{I}_{or}/I_{oc} (dB)	Missed ACK probability
1	VA30	-31.6	0.6	0.01

To pass the test,

the ratio (missed(ACK) / all valid ACKs, sent) ≤ 0.01

NOTE: If the above Test Requirement differs from the Minimum Requirement then the Test Tolerance applied for this test is non-zero. The Test Tolerance for this test is defined in clause F.2 and the explanation of how the Minimum Requirement has been relaxed by the Test Tolerance is given in clause F.4.

10.2.2 Detection in Inter-Cell Handover conditions

10.2.2.1 RLS not containing the Serving E-DCH cell

10.2.2.1.1 RLS not containing the Serving E-DCH cell (10ms TTI)

10.2.2.1.1.1 Definition and applicability

The receive characteristics of the E-DCH HARQ ACK Indicator Channel (E-HICH) is determined during an inter-cell soft handover by the missed ACK and false ACK error probabilities. During the soft handover a UE receives signals from different cells. A UE has to be able to detect E-HICH signalling from different cells belonging to different RLS, not containing the Serving E-DCH cell.

The requirements and this test apply to Release 6 and later releases for all types of UTRA for the FDD UE that support E-DCH and HSDPA.

10.2.2.1.1.2 Minimum requirement

For the parameters specified in Table 10.2.2.1.1.2.1 the average downlink E-HICH E_c/I_{or} power ratio of cell belonging to RLS not containing the Serving E-DCH cell shall be below the specified value for the missed ACK probabilities in Table 10.2.2.1.1.2.2. For the parameters specified in Table 10.2.2.1.1.2.1 the false ACK probability shall be below the specified value in Table 10.2.2.1.1.2.3

Table 10.2.2.1.1.2.1: Requirement scenario parameters for E-HICH – cell belonging to RLS not containing the Serving E-DCH cell

Parameter	Unit	Missed ACK	False ACK
I_{oc}	dBm/3.84 MHz	-60	
Phase reference	-	P-CPICH	
P-CPICH E_c/I_{or} (*)	dB	-10	
E-HICH signalling pattern for the Serving E-DCH cell	-	100% NACK (-1) ¹	100% NACK (-1) ¹
E-HICH signalling pattern for cell belonging to RLS not containing the Serving E-DCH cell	-	100% ACK (+1)	100% NACK (0)
Note 1 The Serving E-DCH cell E-HICH E_c/I_{or} power level is set to -16 dB when hybrid ARQ acknowledgement indicator is transmitted using 3 consecutive slots and to -23 dB when hybrid ARQ acknowledgement indicator is transmitted using 12 consecutive slots.			

Table 10.2.2.1.1.2.2: Minimum requirement for Missed ACK when hybrid ARQ acknowledgement indicator is transmitted using 12 consecutive slots – cell belonging to RLS not containing the Serving E-DCH cell

Test Number	Propagation Conditions	Reference value		
		E-HICH E_c/I_{or} (dB)	\hat{I}_{or1}/I_{oc} and \hat{I}_{or2}/I_{oc} (dB)	Missed ACK probability
1	VA30	-23.6	0	0.05

Table 10.2.2.1.1.2.3: Minimum requirement for False ACK when hybrid ARQ acknowledgement indicator is transmitted using 12 consecutive slots – cell belonging to RLS not containing the Serving E-DCH cell

Test Number	Propagation Conditions	Reference value	
		\hat{I}_{or1}/I_{oc} and \hat{I}_{or2}/I_{oc} (dB)	False ACK probability
2	VA30	0	2E-4

The reference for this requirement is TS 25.101 [1] clause 10.2.2.

10.2.2.1.1.3 Test Purpose

Note: Through all the text below including clause 10.2.2.1.5 the following abbreviation holds: Cell 1: cell belonging to RLS containing the Serving E-DCH cell, Cell 2: cell belonging to RLS not containing the Serving E-DCH cell

To verify that during an inter-cell soft handover for cell 2 the average probability for missed ACK and the average probability for false ACK, when E-HICH is transmitted using 12 consecutive slots, does not exceed specified values.

10.2.2.1.1.4 Method of test

10.2.2.1.1.4.1 Initial conditions

Test environment: normal; see clauses G.2.1 and G.2.2.

Frequencies to be tested: mid range; see clause G.2.4.

- 1) Connect the SS and AWGN noise source and fading simulators to the UE antenna connector as shown in figure Figure A.11.
- 2) The UL Reference Measurement Channel parameters are defined in Annex C.11.
- 3) Set the test parameters for the missed ACK and false ACK test as specified in table 10.2.2.1.1.5.1 to 10.2.2.1.1.5.3 and table E.5A.3, with the exception of \hat{I}_{or2} that shall be set to $-\infty$. Set the fading conditions to VA30.
- 4) The value of Absolute Grant Scope shall be set to 0, and the Absolute Grant shall be set to 5
- 5) The relative grant is not configured. This ensures that the UL datarate remains constant.
- 6) The UE is switched on.
- 7) Enter the UE into loopback mode 1, looping back both the 12.2kbps RMC and HSDPA to E-DCH, and start the loopback test. See TS 34.108 [3] clause 7.3.9 and TS 34.109 [4] clauses 5.3.2.3 and 5.3.2.6. To fill the RLC transmit buffer, run the loopback for [3]s before starting the procedure
- 8) Set \hat{I}_{or2} according to tables 10.2.2.1.1.5.2 to 10.2.2.1.1.5.3. The downlink DPCH of cell 2 must remain inactivated.
- 9) UE shall transmit a MEASUREMENT REPORT message triggered by event 1A containing the CFN-SFN time difference between cell 1 and cell 2.
- 10) The downlink DPCH of cell 2 shall be activated.
- 11) SS shall send an ACTIVE SET UPDATE message, adding cell 2 to the active set.
- 12) The fading simulators are switched on.

10.2.2.1.1.4.2 Procedure

Note: The measurement principle for the missed ACK test (step 2 to 5) and for the false ACK test (step 6 to 9) is as follows. Upon the UE transmission on E-DPCCH and E-DPDCH, the SS responds with E-HICH = ACK on the cell 2 and with E-HICH = NACK on the cell 1. The UE transmits new data or retransmissions on the corresponding E-DPCCH and E-DPDCH. The SS shall discriminate between:

- (1) new data is a sign for ACK, received by the UE from any of the cells
- (2) retransmission is a sign for NACK received by the UE on both cells.

1. The Nominal Avg. Information Bit Rate in the DL is set to 534 kbps according to QPSK H-Set 1. The expected throughput under this level and fading conditions is tested with a single cell in clause 9.2.1, but the DL throughput for this test case will be less than for the single cell case because of interference from Cell 2. The DL throughput for this test case is estimated based on the HSDPA throughput corresponding to the subtests using "HS-PDSCH Ec/Ior = -6dB" condition in 9.2.1A. The worst case for a conformant UE is 22 kbps. The UL data rate was configured by signalling AG value 5 on the E-AGCH. The expected UL datarate is 71.6 kbps corresponding to E-TFC Index 45.
2. In the test Missed ACK the SS responds with 100% NACK (-1) on cell 1 and 100% ACK (1) cell 2.
3. If the UE indicates on the E-DPCCH a retransmission, the ACK from cell 2 was received as NACK by the UE. This is counted as missed (ACK). If the UE indicates on the E-DPCCH new data, the ACK from cell 2 was received as ACK by the UE. This is counted as correct ACK.
4. Continue until statistical significance according to Annex F.6.4 is achieved.
5. If the number of retransmissions reaches the maximum number of retransmissions due to several false or missed ACK detections in series, the first new data on the E-DPDCH with E-DPCCH are not the consequence of ACK. This case is not counted as sample.
6. In the test false ACK the SS responds with 100% NACK (-1) on cell 1 and with 100% NACK (0) on cell 2.

7. If the UE indicates on the E-DPCCH new data, the NACK (DTX) from the SS on cell 2 was received as ACK by the UE. This is counted as false(ACK). If the UE indicates on the the E-DPCCH retransmission, then NACK (DTX) from cell 2 was received as NACK by the UE. This is counted as correct reception.
8. Continue until statistical significance according to Annex F.6.4 is achieved.
9. The number of retransmissions will reach the maximum number of transmissions due to several retransmissions in series. The first new data on the E-DPDCH with E-DPCCH are not the consequence of ACK received by the UE. This case is not counted as sample.

Specific Message Contents

All messages indicated above shall use the same content as described in the default message content in clause 9.2.1 of 34.108 [3] with the following exceptions:

RADIO BEARER SETUP:

Information Element	Value/remark
-RLC PDU size	112
- E-DCH Transmission Time	10 ms
E-DCH MAC-d flow maximum number of retransmissions	15 (max)
E-DCH info	
- Happy bit delay condition	10 ms

ACTIVE SET UPDATE message:

Information Element/Group name	Value/Remark	Version
Message Type (10.2.17)		
UE information elements - RRC transaction identifier - Integrity check info -message authentication code -RRC message sequence number - Activation time - New U-RNTI - New H-RNTI - New Primary E-RNTI - New Secondary E-RNTI	0 SS calculates the value of MAC-I for this message and writes to this IE. The first/ leftmost bit of the bit string contains the most significant bit of the MAC-I. SS provides the value of this IE, from its internal counter. "now". Not Present Not Present Not Present Not Present	 Rel-6 Rel-6 Rel-6
CN information elements - CN Information info	Not Present	
Phy CH information elements Uplink radio resources - Maximum allowed UL TX power	33 dBm	
Downlink radio resources - Radio link addition information - Radio link addition information - Primary CPICH info - Primary scrambling code - Downlink DPCH info for each RL	1 Same as adding cell	
- CHOICE mode - Primary CPICH usage for channel estimation - DPCH frame offset - Secondary CPICH info	FDD Primary CPICH may be used This should be reflected by the IE" Cell synchronisation information" in received MEASUREMENT REPORT message Not Present	
- DL channelisation code - Secondary scrambling code - Spreading factor - Code number - Scrambling code change - TPC combination index - Closed loop timing adjustment mode - Downlink F-DPCH info for each RL	Not Present 128 96 No code change 1 Not Present Not Present	
E-HICH Information - Channelisation Code - Signature Sequence	6 1	Rel-6
E-RGCH Information	Not Present	Rel-6
- Radio link removal information - TX Diversity Mode	Not Present Not Present	
Serving HS-DSCH cell information	Not Present	Rel-6
E-DCH reconfiguration information	Not Present	Rel-6

10.2.2.1.1.5 Test Requirements

For table 10.2.2.1.1.5.1, the average downlink E- HICH E_c/I_{or} power ratio shall be below the specified value for missed ACK probability in Table 10.2.2.1.1.5.2. For table 10.2.2.1.1.5.1, the false ACK probability shall be below the specified value in Table 10.2.2.1.1.5.3

Table 10.2.2.1.1.5.1: Requirement scenario parameters for E-HICH – cell belonging to RLS not containing the Serving E-DCH cell

Parameter Note 1	Unit	Missed ACK	False ACK
I_{oc}	dBm/3.84 MHz	-60	
Phase reference	-	P-CPICH	
E-HICH ₁ E_c/I_{or}	dB	-22.9	
E-HICH ₂ E_c/I_{or}	dB	-23.5 (test1)	$-\infty$ (test 2)
HS-DPSCH ₁ E_c/I_{or}	dB	-2.9(test 1)	-2.9(test 2)
E-HICH signalling pattern for the Serving E-DCH cell	-	100% NACK (-1) ¹	100% NACK (-1) ¹
E-HICH signalling pattern for cell belonging to RLS not containing the Serving E-DCH cell	-	100% ACK (+1)	100% NACK (0)
Note 1	Index 1: cell belonging to RLS containing the Serving E-DCH cell, Index 2: cell belonging to RLS not containing the Serving E-DCH cell.		

Table 10.2.2.1.1.5.2: Test requirement for Missed ACK when hybrid ARQ acknowledgement indicator is transmitted using 12 consecutive slots – cell belonging to RLS not containing the Serving E-DCH cell

Test Number	Propagation Conditions	Reference value		
		E-HICH E_c/I_{or} (dB)	\hat{I}_{or1}/I_{oc} and \hat{I}_{or2}/I_{oc} (dB)	Missed ACK probability
1	VA30	-23.5	0.6	0.05

Table 10.2.2.1.1.5.3: Test requirement for False ACK when hybrid ARQ acknowledgement indicator is transmitted using 12 consecutive slots – cell belonging to RLS not containing the Serving E-DCH cell

Test Number	Propagation Conditions	Reference value	
		\hat{I}_{or1}/I_{oc} and \hat{I}_{or2}/I_{oc} (dB)	False ACK probability
2	VA30	0.6	2E-4

To pass the test,

The ratio (missed (ACK) / all valid ACKs, sent) ≤ 0.05 and

The ratio (false (ACK) / all valid samples) ≤ 0.0002

NOTE: If the above Test Requirement differs from the Minimum Requirement then the Test Tolerance applied for this test is non-zero. The Test Tolerance for this test is defined in clause F.2 and the explanation of how the Minimum Requirement has been relaxed by the Test Tolerance is given in clause F.4.

10.2.2.1.1A RLS not containing the Serving E-DCH cell (10ms TTI, Type 1)

10.2.2.1.1A.1 Definition and applicability

The receive characteristics of the E-DCH HARQ ACK Indicator Channel (E-HICH) is determined during an inter-cell soft handover by the missed ACK error probabilities. During the soft handover a UE receives signals from different cells. A UE has to be able to detect E-HICH signalling from different cells belonging to different RLS, not containing the Serving E-DCH cell.

The requirements and this test apply to Release 7 and later releases for all types of UTRA FDD UEs that support E-DCH and HSDPA and the optional Type 1 enhanced performance requirements.

10.2.2.1.1A.2 Minimum requirement

For the parameters specified in Table 10.2.2.1.1A.2.1 the average downlink E-HICH E_c/I_{or} power ratio of cell belonging to RLS not containing the Serving E-DCH cell shall be below the specified value for the missed ACK probabilities in Table 10.2.2.1.1A.2.2.

Table 10.2.2.1.1A.2.1: Requirement scenario parameters for E-HICH – cell belonging to RLS not containing the Serving E-DCH cell

Parameter	Unit	Missed ACK
I_{oc}	dBm/3.84 MHz	-60
Phase reference	-	P-CPICH
P-CPICH E_c/I_{or} (*)	dB	-10
E-HICH signalling pattern for the Serving E-DCH cell	-	100% NACK (-1) ¹
E-HICH signalling pattern for cell belonging to RLS not containing the Serving E-DCH cell	-	100% ACK (+1)
Note 1 The Serving E-DCH cell E-HICH E_c/I_{or} power level is set to -16 dB when hybrid ARQ acknowledgement indicator is transmitted using 3 consecutive slots and to -23 dB when hybrid ARQ acknowledgement indicator is transmitted using 12 consecutive slots.		

Table 10.2.2.1.1A.2.2: Enhanced performance requirement Type 1 for Missed ACK when hybrid ARQ acknowledgement indicator is transmitted using 12 consecutive slots – cell belonging to RLS not containing the Serving E-DCH cell

Test Number	Propagation Conditions	Reference value		
		E-HICH E_c/I_{or} (dB)	\hat{I}_{or1}/I_{oc} and \hat{I}_{or2}/I_{oc} (dB)	Missed ACK probability
1	VA30	-27.8	0	0.05

The reference for this requirement is TS 25.101 [1] clause 10.2.2.

10.2.2.1.1A.3 Test Purpose

Note: Through all the text below including clause 10.2.2.1.5 the following abbreviation holds: Cell 1: cell belonging to RLS containing the Serving E-DCH cell, Cell 2: cell belonging to RLS not containing the Serving E-DCH cell

To verify that during an inter-cell soft handover for cell 2 the average probability for missed ACK, when E-HICH is transmitted using 12 consecutive slots, does not exceed specified values.

10.2.2.1.1A.4 Method of test

10.2.2.1.1A.4.1 Initial conditions

Test environment: normal; see clauses G.2.1 and G.2.2.

Frequencies to be tested: mid range; see clause G.2.4.

- 1) Connect the SS and AWGN noise source and fading simulators to the UE antenna connector as shown in figure Figure A.24 for UEs that support receive diversity or figure A.11 for UEs that do not support receive diversity..
- 2) The UL Reference Measurement Channel parameters are defined in Annex C.11
- 3) Set the test parameters for the missed ACK test as specified in table 10.2.2.1.1A.5.1 and 10.2.2.1.1A.5.2 and table E.5A.3 with the exception of \hat{I}_{or2} that shall be set to $-\infty$.. Set the fading conditions to VA 30
- 4) The value of Absolute Grant Scope shall be set to 0, and the Absolute Grant shall be set to 5
- 5) The relative grant is not configured. This ensures that the UL datarate remains constant.
- 6) The UE is switched on.
- 7) Enter the UE into loopback mode 1, looping back both the 12.2kbps RMC and HSDPA to E-DCH, and start the loopback test. See TS 34.108 [3] clause 7.3.9 and TS 34.109 [4] clauses 5.3.2.3 and 5.3.2.6. To fill the RLC transmit buffer, run the loopback for [3]s before starting the procedure

- 8) Set \hat{I}_{or2} according to tables 10.2.2.1.1A.5.1 to 10.2.2.1.1A.5.2. The downlink DPCH of cell 2 must remain inactivated.
- 9) UE shall transmit a MEASUREMENT REPORT message triggered by event 1A containing the CFN-SFN time difference between cell 1 and cell 2.
- 10) The downlink DPCH of cell 2 shall be activated.
- 11) SS shall send an ACTIVE SET UPDATE message, adding cell 2 to the active set.
- 12) The fading simulators are switched on

10.2.2.1.1A.4.2 Procedure

Note: The measurement principle for the missed ACK test (step 2 to 5) is as follows. Upon the UE transmission on E-DPCCH and E-DPDCH, the SS responds with E-HICH = ACK on the cell 2 and with E-HICH = NACK on the cell 1. The UE transmits new data or retransmissions on the corresponding E-DPCCH and E-DPDCH. The SS shall discriminate between:

- (1) new data is a sign for ACK, received by the UE from any of the cells
 - (2) retransmission is a sign for NACK received by the UE on both cells.
1. The Nominal Avg. Information Bit Rate in the DL is set to 534 kbps according to QPSK H-Set 1. The expected throughput under this level and fading conditions is tested with a single cell in clause 9.2.1, but the DL throughput for this test case will be less than for the single cell case because of interference from Cell 2. The DL throughput for this test case is estimated based on the HSDPA throughput corresponding to the subtests using "HS-PDSCH $E_c/I_{or} = -6\text{dB}$ " condition in 9.2.1A. The worst case for a conformant UE is 22 kbps. The UL data rate was configured by signalling AG value 5 on the E-AGCH. The expected UL data rate is 71.6 kbps corresponding to E-TFC Index 45.
 2. In the test Missed ACK the SS responds with 100% NACK (-1) on cell 1 and 100% ACK (1) cell 2.
 3. If the UE indicates on the E-DPCCH a retransmission, the ACK from cell 2 was received as NACK by the UE. This is counted as missed (ACK). If the UE indicates on the E-DPCCH new data, the ACK from cell 2 was received as ACK by the UE. This is counted as correct ACK.
 4. Continue until statistical significance according to Annex F.6.4 is achieved.
 5. If the number of retransmissions reaches the maximum number of retransmissions due to several false or missed ACK detections in series, the first new data on the E-DPDCH with E-DPCCH are not the consequence of ACK. This case is not counted as sample.

Specific Message Contents

All messages indicated above shall use the same content as described in the default message content in clause 9.2.1 of 34.108 [3] with the following exceptions:

RADIO BEARER SETUP:

Information Element	Value/remark
-RLC PDU size	112
- E-DCH Transmission Time	10 ms
E-DCH MAC-d flow maximum number of retransmissions	15 (max)
E-DCH info	
- Happy bit delay condition	10 ms

ACTIVE SET UPDATE message:

Information Element/Group name	Value/Remark	Version
Message Type (10.2.17)		
UE information elements - RRC transaction identifier - Integrity check info -message authentication code -RRC message sequence number - Activation time - New U-RNTI - New H-RNTI - New Primary E-RNTI - New Secondary E-RNTI	0 SS calculates the value of MAC-I for this message and writes to this IE. The first/ leftmost bit of the bit string contains the most significant bit of the MAC-I. SS provides the value of this IE, from its internal counter. "now". Not Present Not Present Not Present Not Present	 Rel-6 Rel-6 Rel-6
CN information elements - CN Information info	Not Present	
Phy CH information elements Uplink radio resources - Maximum allowed UL TX power	33 dBm	
Downlink radio resources - Radio link addition information - Radio link addition information - Primary CPICH info - Primary scrambling code - Downlink DPCH info for each RL	1 Same as adding cell	
- CHOICE mode - Primary CPICH usage for channel estimation - DPCH frame offset - Secondary CPICH info	FDD Primary CPICH may be used This should be reflected by the IE" Cell synchronisation information" in received MEASUREMENT REPORT message Not Present	
- DL channelisation code - Secondary scrambling code - Spreading factor - Code number - Scrambling code change - TPC combination index - Closed loop timing adjustment mode - Downlink F-DPCH info for each RL	Not Present 128 96 No code change 1 Not Present Not Present	
E-HICH Information - Channelisation Code - Signature Sequence	6 1	Rel-6
E-RGCH Information	Not Present	Rel-6
- Radio link removal information - TX Diversity Mode	Not Present Not Present	
Serving HS-DSCH cell information	Not Present	Rel-6
E-DCH reconfiguration information	Not Present	Rel-6

10.2.2.1.1A.5 Test Requirements

For Table 10.2.2.1.1A.5.1, the average downlink E- HICH E_c/I_{or} power ratio shall be below the specified value for missed ACK probability in Table 10.2.2.1.1A.5.2.

Table 10.2.2.1.1A.5.1: Requirement scenario parameters for E-HICH – cell belonging to RLS not containing the Serving E-DCH cell

Parameter Note 1	Unit	Missed ACK
I_{oc}	dBm/3.84 MHz	-60
Phase reference	-	P-CPICH
E-HICH ₁ E_c/I_{or}	dB	-22.9
E-HICH ₂ E_c/I_{or}	dB	-27.7 (test1)
HS-DPSCH ₁ E_c/I_{or}	dB	-2.9(test 1)
E-HICH signalling pattern for the Serving E-DCH cell	-	100% NACK (-1) ¹
E-HICH signalling pattern for cell belonging to RLS not containing the Serving E-DCH cell	-	100% ACK (+1)
Note 1	Index 1: cell belonging to RLS containing the Serving E-DCH cell, Index 2: cell belonging to RLS not containing the Serving E-DCH cell.	

Table 10.2.2.1.1A.5.2: Test requirement Type 1 for Missed ACK when hybrid ARQ acknowledgement indicator is transmitted using 12 consecutive slots – cell belonging to RLS not containing the Serving E-DCH cell

Test Number	Propagation Conditions	Reference value		
		E-HICH E_c/I_{or} (dB)	\hat{I}_{or1}/I_{oc} and \hat{I}_{or2}/I_{oc} (dB)	Missed ACK probability
1	VA30	-27.7	0.6	0.05

To pass the test,

The ratio (missed (ACK) / all valid ACKs, sent) \leq 0.05

NOTE: If the above Test Requirement differs from the Minimum Requirement then the Test Tolerance applied for this test is non-zero. The Test Tolerance for this test is defined in clause F.2 and the explanation of how the Minimum Requirement has been relaxed by the Test Tolerance is given in clause F.4.

10.2.2.1.2 RLS not containing the Serving E-DCH cell (2ms TTI)

10.2.2.1.2.1 Definition and applicability

The receive characteristics of the E-DCH HARQ ACK Indicator Channel (E-HICH) is determined during an inter-cell soft handover by the missed ACK and false ACK error probabilities. During the soft handover a UE receives signals from different cells. A UE has to be able to detect E-HICH signalling from different cells belonging to different RLS, not containing the Serving E-DCH cell.

The requirements and this test apply to Release 6 and later releases for all types of UTRA for the FDD UE that support E-DCH with 2ms TTI and HSDPA.

10.2.2.1.2.2 Minimum requirement

For the parameters specified in Table 10.2.2.1.2.2.1 the average downlink E-HICH E_c/I_{or} power ratio of cell belonging to RLS not containing the Serving E-DCH cell shall be below the specified value for the missed ACK probabilities in Table 10.2.2.1.2.2.2. For the parameters specified in Table 10.2.2.1.2.2.1 the false ACK probability shall be below the specified value in Table 10.2.2.1.2.2.3.

Table 10.2.2.1.2.2.1: Requirement scenario parameters for E-HICH – cell belonging to RLS not containing the Serving E-DCH cell

Parameter	Unit	Missed ACK	False ACK
I_{oc}	dBm/3.84 MHz	-60	
Phase reference	-	P-CPICH	
P-CPICH E_c/I_{or} (*)	dB	-10	
E-HICH signalling pattern for the Serving E-DCH cell	-	100% NACK (-1) ¹	100% NACK (-1) ¹
E-HICH signalling pattern for cell belonging to RLS not containing the Serving E-DCH cell	-	100% ACK (+1)	100% NACK (0)
Note 1 The Serving E-DCH cell E-HICH E_c/I_{or} power level is set to -16 dB when hybrid ARQ acknowledgement indicator is transmitted using 3 consecutive slots and to -23 dB when hybrid ARQ acknowledgement indicator is transmitted using 12 consecutive slots.			

Table 10.2.2.1.2.2.2: Minimum requirement for Missed ACK when hybrid ARQ acknowledgement indicator is transmitted using 3 consecutive slots – cell belonging to RLS not containing the Serving E-DCH cell

Test Number	Propagation Conditions	Reference value		
		E-HICH E_c/I_{or} (dB)	\hat{I}_{or1}/I_{oc} and \hat{I}_{or2}/I_{oc} (dB)	Missed ACK probability
1	VA30	-16.3	0	0.05

Table 10.2.2.1.2.2.3: Minimum requirement for False ACK when hybrid ARQ acknowledgement indicator is transmitted using 3 consecutive slots – cell belonging to RLS not containing the Serving E-DCH cell

Test Number	Propagation Conditions	Reference value	
		\hat{I}_{or1}/I_{oc} and \hat{I}_{or2}/I_{oc} (dB)	False ACK probability
2	VA30	0	2E-4

The reference for this requirement is TS 25.101 [1] clause 10.2.2.

10.2.2.1.2.3 Test Purpose

Note: Through all the text below including clause 10.2.2.1.2.5 the following abbreviation holds: Cell 1: cell belonging to RLS containing the Serving E-DCH cell, Cell 2: cell belonging to RLS not containing the Serving E-DCH cell

To verify that during an inter-cell soft handover for cell 2 the average probability for missed ACK and the average probability for false ACK, when E-HICH is transmitted using 3 consecutive slots, does not exceed specified values.

10.2.2.1.2.4 Method of test

10.2.2.1.2.4.1 Initial conditions

Test environment: normal; see clauses G.2.1 and G.2.2.

Frequencies to be tested: mid range; see clause G.2.4.

- 1) Connect the SS and AWGN noise source and fading simulators to the UE antenna connector as shown in Figure A.11.
- 2) The UL Reference Measurement Channel parameters are defined in Annex C.11.
- 3) Set the test parameters for the missed ACK and false ACK test as specified in table 10.2.2.1.2.5.1 to 10.2.2.1.2.5.3 and table E.5A.3 with the exception of \hat{I}_{or2} that shall be set to $-\infty$. Set the fading conditions to VA30

- 4) The value of Absolute Grant Scope shall be set to 0 and the Absolute Grant shall be set to 3.
- 5) The relative grant is not configured. This ensures that the UL datarate remains constant.
- 6) The UE is switched on.
- 7) Enter the UE into loopback mode 1, looping back both the 12.2kbps RMC and HSDPA to E-DCH, and start the loopback test. See TS 34.108 [3] clause 7.3.9 and TS 34.109 [4] clauses 5.3.2.3 and 5.3.2.6. To fill the RLC transmit buffer, run the loopback for [3]s before starting the procedure.
- 8) Set \hat{I}_{or2} according to tables 10.2.2.1.2.5.2 to 10.2.2.1.2.5.3. The downlink DPCH of cell 2 must remain inactivated.
- 9) UE shall transmit a MEASUREMENT REPORT message triggered by event 1A containing the CFN-SFN time difference between cell 1 and cell 2.
- 10) The downlink DPCH of cell 2 shall be activated.
- 11) SS shall send an ACTIVE SET UPDATE message, adding cell 2 to the active set.
- 12) The fading simulators are switched on.

10.2.2.1.2.4.2 Procedure

Note: The measurement principle for the missed ACK test (step 2 to 5) and for the false ACK test (step 6 to 9) is as follows. Upon the UE transmission on E-DPCCH and E-DPDCH, the SS responds with E-HICH = ACK on the cell 2 and with E-HICH = NACK on the cell 1. The UE transmits new data or retransmissions on the corresponding E-DPCCH and E-DPDCH. The SS shall discriminate between:

- (1) new data is a sign for ACK, received by the UE from any of the cells
- (2) retransmission is a sign for NACK received by the UE on both cells.

1. The Nominal Avg. Information Bit Rate in the DL is set to 534 kbps according to QPSK H-Set 1. The expected throughput under this level and fading conditions is tested with a single cell in clause 9.2.1, but the DL throughput for this test case will be less than for the single cell case because of interference from Cell 2. The DL throughput for this test case is estimated based on the HSDPA throughput corresponding to the subtests using "HS-PDSCH Ec/Ior = -6dB" condition in 9.2.1A. The worst case for a conformant UE is 22 kbps. The UL data rate was configured by signalling AG value 3 on the E-AGCH. The expected UL datarate is 123.5 kbps corresponding to E-TFC Index 21
2. In the test Missed ACK the SS responds with 100% NACK (-1) on cell 1 and 100% ACK (1) cell 2.
3. If the UE indicates on the the E-DPCCH a retransmission, the ACK from cell 2 was received as NACK by the UE. This is counted as missed (ACK). If the UE indicates on the E-DPCCH new data, the ACK from cell 2 was received as ACK by the UE. This is counted as correct ACK.
4. Continue until statistical significance according to Annex F.6.4 is achieved.
5. If the number of retransmissions reaches the maximum number of retransmissions due to several false or missed ACK detections in series, the first new data on the E-DPDCH with E-DPCCH are not the consequence of ACK. This case is not counted as sample.
6. In the test false ACK the SS responds with 100% NACK (-1) on cell 1 and with 100% NACK (0) on cell 2.
7. If the UE indicates on the the E-DPCCH new data, the NACK (DTX) from the SS on cell 2 was received as ACK by the UE. This is counted as false(ACK). If the UE indicates on the the E-DPCCH retransmission, then NACK (DTX) from cell 2 was received as NACK by the UE. This is counted as correct reception.
8. Continue until statistical significance according to Annex F.6.4 is achieved.
9. The number of retransmissions will reach the maximum number of transmissions due to several retransmissions in series. The first new data on the E-DPDCH with E-DPCCH are not the consequence of ACK received by the UE. This case is not counted as sample.

Specific Message Contents

All messages indicated above shall use the same content as described in the default message content in clause 9.2.1 of 34.108 [3] with the following exceptions:

RADIO BEARER SETUP:

Information Element	Value/remark
-RLC PDU size	112
- E-DCH Transmission Time	2ms
E-DCH MAC-d flow maximum number of retransmissions	15 (max)
E-DCH info	
- Happy bit delay condition	2ms

ACTIVE SET UPDATE message:

Information Element/Group name	Value/Remark	Version
Message Type (10.2.17)		
UE information elements - RRC transaction identifier - Integrity check info -message authentication code -RRC message sequence number - Activation time - New U-RNTI - New H-RNTI - New Primary E-RNTI - New Secondary E-RNTI	0 SS calculates the value of MAC-I for this message and writes to this IE. The first/ leftmost bit of the bit string contains the most significant bit of the MAC-I. SS provides the value of this IE, from its internal counter. "now". Not Present Not Present Not Present Not Present	 Rel-6 Rel-6 Rel-6
CN information elements - CN Information info	Not Present	
Phy CH information elements Uplink radio resources - Maximum allowed UL TX power	33 dBm	
Downlink radio resources - Radio link addition information - Radio link addition information - Primary CPICH info - Primary scrambling code - Downlink DPCH info for each RL	1 Same as adding cell	
- CHOICE mode - Primary CPICH usage for channel estimation - DPCH frame offset - Secondary CPICH info	FDD Primary CPICH may be used This should be reflected by the IE" Cell synchronisation information" in received MEASUREMENT REPORT message Not Present	
- DL channelisation code - Secondary scrambling code - Spreading factor - Code number - Scrambling code change - TPC combination index - Closed loop timing adjustment mode - Downlink F-DPCH info for each RL	Not Present 128 96 No code change 1 Not Present Not Present	
E-HICH Information - Channelisation Code - Signature Sequence	6 1	Rel-6
E-RGCH Information	Not Present	Rel-6
- Radio link removal information - TX Diversity Mode	Not Present Not Present	
Serving HS-DSCH cell information	Not Present	Rel-6
E-DCH reconfiguration information	Not Present	Rel-6

10.2.2.1.2.5 Test Requirements

For table 10.2.2.1.2.5.1, the average downlink E- HICH E_c/I_{or} power ratio shall be below the specified value for missed ACK probability in Table 10.2.2.1.2.5.2. For table 10.2.2.1.2.5.1, the false ACK probability shall be below the specified value in Table 10.2.2.1.2.5.3

Table 10.2.2.1.2.5.1: Requirement scenario parameters for E-HICH – cell belonging to RLS not containing the Serving E-DCH cell

Parameter Note 1	Unit	Missed ACK	False ACK
I_{oc}	dBm/3.84 MHz	-60	
Phase reference	-	P-CPICH	
E-HICH ₁ E_c/I_{or}	dB	-15.9	
E-HICH ₂ E_c/I_{or}	dB	-16.2 (test 1)	$-\infty$ (test 2)
HS-DPSCH ₁ E_c/I_{or}	dB	-3.1(test 1)	-3.1(test 2)
E-HICH signalling pattern for the Serving E-DCH cell	-	100% NACK (-1) ¹	100% NACK (-1) ¹
E-HICH signalling pattern for cell belonging to RLS not containing the Serving E-DCH cell	-	100% ACK (+1)	100% NACK (0)
Note 1	Index 1: cell belonging to RLS containing the Serving E-DCH cell, Index 2: cell belonging to RLS not containing the Serving E-DCH cell.		

Table 10.2.2.1.2.5.2 Test requirement for Missed ACK when hybrid ARQ acknowledgement indicator is transmitted using 3 consecutive slots – cell belonging to RLS not containing the Serving E-DCH cell

Test Number	Propagation Conditions	Reference value		
		E-HICH E_c/I_{or} (dB)	\hat{I}_{or1}/I_{oc} and \hat{I}_{or2}/I_{oc} (dB)	Missed ACK probability
1	VA30	-16.2	0.6	0.05

Table 10.2.2.1.2.5.3: Test requirement for False ACK when hybrid ARQ acknowledgement indicator is transmitted using 3 consecutive slots – cell belonging to RLS not containing the Serving E-DCH cell

Test Number	Propagation Conditions	Reference value	
		\hat{I}_{or1}/I_{oc} and \hat{I}_{or2}/I_{oc} (dB)	False ACK probability
2	VA30	0.6	2E-4

To pass the test,

The ratio (missed (ACK) / all valid ACKs, sent) ≤ 0.05 and

The ratio (false (ACK) / all valid samples) ≤ 0.0002

NOTE: If the above Test Requirement differs from the Minimum Requirement then the Test Tolerance applied for this test is non-zero. The Test Tolerance for this test is defined in clause F.2 and the explanation of how the Minimum Requirement has been relaxed by the Test Tolerance is given in clause F.4.

10.2.2.1.2A RLS not containing the Serving E-DCH cell (2ms TTI, Type 1)

10.2.2.1.2A.1 Definition and applicability

The receive characteristics of the E-DCH HARQ ACK Indicator Channel (E-HICH) is determined during an inter-cell soft handover by the missed ACK error probabilities. During the soft handover a UE receives signals from different cells. A UE has to be able to detect E-HICH signalling from different cells belonging to different RLS, not containing the Serving E-DCH cell.

The requirements and this test apply to Release 7 and later releases for all types of UTRA FDD UEs that support E-DCH with 2ms TTI and HSDPA and the optional Type 1 enhanced performance requirements.

10.2.2.1.2A.2 Minimum requirement

For the parameters specified in Table 10.2.2.1.2A.2.1 the average downlink E-HICH E_c/I_{or} power ratio of cell belonging to RLS not containing the Serving E-DCH cell shall be below the specified value for the missed ACK probabilities in Table 10.2.2.1.2A.2.2.

Table 10.2.2.1.2A.2.1: Requirement scenario parameters for E-HICH – cell belonging to RLS not containing the Serving E-DCH cell

Parameter	Unit	Missed ACK
I_{oc}	dBm/3.84 MHz	-60
Phase reference	-	P-CPICH
P-CPICH E_c/I_{or} (*)	dB	-10
E-HICH signalling pattern for the Serving E-DCH cell	-	100% NACK (-1) ¹
E-HICH signalling pattern for cell belonging to RLS not containing the Serving E-DCH cell	-	100% ACK (+1)
Note 1 The Serving E-DCH cell E-HICH E_c/I_{or} power level is set to -16 dB when hybrid ARQ acknowledgement indicator is transmitted using 3 consecutive slots and to -23 dB when hybrid ARQ acknowledgement indicator is transmitted using 12 consecutive slots.		

Table 10.2.2.1.2A.2.2: Enhanced performance requirement for Missed ACK when hybrid ARQ acknowledgement indicator is transmitted using 3 consecutive slots – cell belonging to RLS not containing the Serving E-DCH cell

Test Number	Propagation Conditions	Reference value		
		E-HICH E_c/I_{or} (dB)	\hat{I}_{or1}/I_{oc} and \hat{I}_{or2}/I_{oc} (dB)	Missed ACK probability
1	VA30	-20.6	0	0.05

The reference for this requirement is TS 25.101 [1] clause 10.2.2.

10.2.2.1.2A.3 Test Purpose

Note: Through all the text below including clause 10.2.2.1.2.5 the following abbreviation holds: Cell 1: cell belonging to RLS containing the Serving E-DCH cell, Cell 2: cell belonging to RLS not containing the Serving E-DCH cell

To verify that during an inter-cell soft handover for cell 2 the average probability for missed ACK, when E-HICH is transmitted using 3 consecutive slots, does not exceed specified values.

10.2.2.1.2A.4 Method of test

10.2.2.1.2A.4.1 Initial conditions

Test environment: normal; see clauses G.2.1 and G.2.2.

Frequencies to be tested: mid range; see clause G.2.4.

- 1) Connect the SS and AWGN noise source and fading simulators to the UE antenna connector as shown in Figure A.24 for UEs that support receive diversity or figure A.11 for UEs that do not support receive diversity..
- 2) The UL Reference Measurement Channel parameters are defined in Annex C.11
- 3) Set the test parameters for the missed ACK test as specified in table 10.2.2.1.2A.5.1 and 10.2.2.1.2A.5.2 and table E.5A.3 with the exception of \hat{I}_{or2} that shall be set to $-\infty$.. Set the fading conditions to VA 30
- 4) The value of Absolute Grant Scope shall be set to 0 and the Absolute Grant shall be set to 3.
- 5) The relative grant is not configured. This ensures that the UL datarate remains constant.

- 6) The UE is switched on.
- 7) Enter the UE into loopback mode 1, looping back both the 12.2kbps RMC and HSDPA to E-DCH, and start the loopback test. See TS 34.108 [3] clause 7.3.9 and TS 34.109 [4] clauses 5.3.2.3 and 5.3.2.6. To fill the RLC transmit buffer, run the loopback for [3]s before starting the procedure.
- 8) Set \hat{I}_{or2} according to tables 10.2.2.1.2A.5.1 to 10.2.2.1.2A.5.2. The downlink DPCH of cell 2 must remain inactivated.
- 9) UE shall transmit a MEASUREMENT REPORT message triggered by event 1A containing the CFN-SFN time difference between cell 1 and cell 2.
- 10) The downlink DPCH of cell 2 shall be activated.
- 11) SS shall send an ACTIVE SET UPDATE message, adding cell 2 to the active set.
- 12) The fading simulators are switched on.

10.2.2.1.2A.4.2 Procedure

Note: The measurement principle for the missed ACK test (step 2 to 5) is as follows. Upon the UE transmission on E-DPCCH and E-DPDCH, the SS responds with E-HICH = ACK on the cell 2 and with E-HICH = NACK on the cell 1. The UE transmits new data or retransmissions on the corresponding E-DPCCH and E-DPDCH. The SS shall discriminate between:

- (1) new data is a sign for ACK, received by the UE from any of the cells
 - (2) retransmission is a sign for NACK received by the UE on both cells.
1. The Nominal Avg. Information Bit Rate in the DL is set to 534 kbps according to QPSK H-Set 1. The expected throughput under this level and fading conditions is tested with a single cell in clause 9.2.1, but the DL throughput for this test case will be less than for the single cell case because of interference from Cell 2. The DL throughput for this test case is estimated based on the HSDPA throughput corresponding to the subtests using "HS-PDSCH $E_c/I_{or} = -6\text{dB}$ " condition in 9.2.1A. The worst case for a conformant UE is 22 kbps. The UL data rate was configured by signalling AG value 3 on the E-AGCH. The expected UL data rate is 123.5 kbps corresponding to E-TFC Index 21
 2. In the test Missed ACK the SS responds with 100% NACK (-1) on cell 1 and 100% ACK (1) cell 2.
 3. If the UE indicates on the E-DPCCH a retransmission, the ACK from cell 2 was received as NACK by the UE. This is counted as missed (ACK). If the UE indicates on the E-DPCCH new data, the ACK from cell 2 was received as ACK by the UE. This is counted as correct ACK.
 4. Continue until statistical significance according to Annex F.6.4 is achieved.
 5. If the number of retransmissions reaches the maximum number of retransmissions due to several false or missed ACK detections in series, the first new data on the E-DPDCH with E-DPCCH are not the consequence of ACK. This case is not counted as sample.

Specific Message Contents

All messages indicated above shall use the same content as described in the default message content in clause 9.2.1 of 34.108 [3] with the following exceptions:

RADIO BEARER SETUP:

Information Element	Value/remark
-RLC PDU size	112
- E-DCH Transmission Time	2ms
E-DCH MAC-d flow maximum number of retransmissions	15 (max)
E-DCH info	
- Happy bit delay condition	2ms

ACTIVE SET UPDATE message:

Information Element/Group name	Value/Remark	Version
Message Type (10.2.17)		
UE information elements - RRC transaction identifier - Integrity check info -message authentication code -RRC message sequence number - Activation time - New U-RNTI - New H-RNTI - New Primary E-RNTI - New Secondary E-RNTI	0 SS calculates the value of MAC-I for this message and writes to this IE. The first/ leftmost bit of the bit string contains the most significant bit of the MAC-I. SS provides the value of this IE, from its internal counter. "now". Not Present Not Present Not Present Not Present	 Rel-6 Rel-6 Rel-6
CN information elements - CN Information info	Not Present	
Phy CH information elements Uplink radio resources - Maximum allowed UL TX power	33 dBm	
Downlink radio resources - Radio link addition information - Radio link addition information - Primary CPICH info - Primary scrambling code - Downlink DPCH info for each RL	1 Same as adding cell	
- CHOICE mode - Primary CPICH usage for channel estimation - DPCH frame offset - Secondary CPICH info	FDD Primary CPICH may be used This should be reflected by the IE" Cell synchronisation information" in received MEASUREMENT REPORT message Not Present	
- DL channelisation code - Secondary scrambling code - Spreading factor - Code number - Scrambling code change - TPC combination index - Closed loop timing adjustment mode - Downlink F-DPCH info for each RL	Not Present 128 96 No code change 1 Not Present Not Present	
E-HICH Information - Channelisation Code - Signature Sequence	6 1	Rel-6
E-RGCH Information	Not Present	Rel-6
- Radio link removal information - TX Diversity Mode	Not Present Not Present	
Serving HS-DSCH cell information	Not Present	Rel-6
E-DCH reconfiguration information	Not Present	Rel-6

10.2.2.1.2A.5 Test Requirements

For table 10.2.2.1.2A.5.1, the average downlink E- HICH E_c/I_{0r} power ratio shall be below the specified value for missed ACK probability in Table 10.2.2.1.2A.5.2

Table 10.2.2.1.2A.5.1: Requirement scenario parameters for E-HICH – cell belonging to RLS not containing the Serving E-DCH cell

Parameter Note 1	Unit	Missed ACK
I_{oc}	dBm/3.84 MHz	-60
Phase reference	-	P-CPICH
E-HICH ₁ E_c/I_{or}	dB	-15.9
E-HICH ₂ E_c/I_{or}	dB	-20.5 (test 1)
HS-DPSCH ₁ E_c/I_{or}	dB	-3.00(test 1)
E-HICH signalling pattern for the Serving E-DCH cell	-	100% NACK (-1) ¹
E-HICH signalling pattern for cell belonging to RLS not containing the Serving E-DCH cell	-	100% ACK (+1)
Note 1 Index 1: cell belonging to RLS containing the Serving E-DCH cell, Index 2: cell belonging to RLS not containing the Serving E-DCH cell.		

Table 10.2.2.1.2A.5.2 Test requirement Type 1 for Missed ACK when hybrid ARQ acknowledgement indicator is transmitted using 3 consecutive slots – cell belonging to RLS not containing the Serving E-DCH cell

Test Number	Propagation Conditions	Reference value		
		E-HICH E_c/I_{or} (dB)	\hat{I}_{or1}/I_{oc} and \hat{I}_{or2}/I_{oc} (dB)	Missed ACK probability
1	VA30	-20.5	0.6	0.05

To pass the test,

The ratio (missed (ACK) / all valid ACKs, sent) \leq 0.05

NOTE: If the above Test Requirement differs from the Minimum Requirement then the Test Tolerance applied for this test is non-zero. The Test Tolerance for this test is defined in clause F.2 and the explanation of how the Minimum Requirement has been relaxed by the Test Tolerance is given in clause F.4.

10.2.2.2 RLS containing the Serving E-DCH cell

10.2.2.2.1 RLS containing the Serving E-DCH cell (10ms TTI)

10.2.2.2.1.1 Definition and applicability

The receive characteristics of the E-DCH HARQ ACK Indicator Channel (E-HICH) is determined during an inter-cell soft handover by the missed ACK and false ACK error probabilities. During the soft handover a UE receives signals from different cells. A UE has to be able to detect E-HICH signalling from different cells belonging to different RLS, containing the Serving E-DCH cell.

The requirements and this test apply to Release 6 and later releases for all types of UTRA for the FDD UE that support E-DCH and HSDPA.

10.2.2.2.1.2 Minimum requirement

For the parameters specified in Table 10.2.2.2.1.2.1 the average downlink E-HICH E_c/I_{or} power ratio of cell belonging to RLS containing the Serving E-DCH cell shall be below the specified value for the missed ACK probabilities in Table 10.2.2.2.1.2.2. For the parameters specified in Table 10.2.2.2.1.2.1 the false ACK probability shall be below the specified value in Table 10.2.2.2.1.2.3

Table 10.2.2.2.1.2.1: Requirement scenario parameters for E-HICH – RLS containing the serving cell in SHO

Parameter	Unit	Missed ACK	False ACK
I_{oc}	dBm/3.84 MHz	-60	
Phase reference	-	P-CPICH	
P-CPICH E_c/I_{or} (*)	dB	-10	
E-HICH signalling pattern for Serving E-DCH cell	-	100% ACK (+1)	100% DTX (0)
E-HICH signalling pattern for cell belonging to RLS not containing the Serving E-DCH cell	-	100% NACK (0)	100% NACK (0)

Table 10.2.2.2.1.2.2: Minimum requirement for Missed ACK when hybrid ARQ acknowledgement indicator is transmitted using 12 consecutive slots – RLS containing the Serving E-DCH cell

Test Number	Propagation Conditions	Reference value		
		E-HICH E_c/I_{or} (dB) for Serving E-DCH cell (ACK)	\hat{I}_{or1}/I_{oc} and \hat{I}_{or2}/I_{oc} (dB)	Missed ACK probability
1	VA30	-29.7	0	0.05

Table 10.2.2.2.1.2.3: Minimum requirement for False ACK when hybrid ARQ acknowledgement indicator is transmitted using 12 consecutive slots – RLS containing the Serving E-DCH cell

Test Number	Propagation Conditions	Reference value	
		\hat{I}_{or1}/I_{oc} and \hat{I}_{or2}/I_{oc} (dB)	False ACK probability
2	PA3	0	0.1
3	VA120	0	0.1

The reference for this requirement is TS 25.101 [1] clause 10.2.2.1

10.2.2.2.1.3 Test purpose

Note: Through all the text below including clause 10.2.2.2.5 the following abbreviation holds: Cell 1: cell belonging to RLS containing the Serving E-DCH cell, Cell 2: cell belonging to RLS not containing the Serving E-DCH cell

To verify that during an inter-cell soft handover for cell 1 the average probability for missed ACK and the average probability for false ACK, when E-HICH is transmitted using 12 consecutive slots, does not exceed specified values.

10.2.2.2.1.4 Method of test

10.2.2.2.1.4.1 Initial conditions

Test environment: normal; see clauses G.2.1 and G.2.2.

Frequencies to be tested: mid range; see clause G.2.4.

- 1) Connect the SS and AWGN noise source and fading simulators to the UE antenna connector as shown in figure Figure A.11.
- 2) The UL Reference Measurement Channel parameters are defined in Annex C.11.
- 3) Set the test parameters for the missed ACK and false ACK test as specified in table 10.2.2.2.1.5.1 to 10.2.2.2.1.5.3 and table E.5A.3, with the exception of \hat{I}_{or2} that shall be set to $-\infty$. Set the fading conditions to VA 30, PA 3 or VA 120
- 4) The value of Absolute Grant Scope shall be set to 0 and the Absolute Grant shall be set to 5.

- 5) The relative grant is not configured. This ensures that the UL datarate remains constant.
- 6) The UE is switched on.
- 7) Enter the UE into loopback mode 1, looping back both the 12.2kbps RMC and HSDPA to E-DCH, and start the loopback test. See TS 34.108 [3] clause 7.3.9 and TS 34.109 [4] clauses 5.3.2.3 and 5.3.2.6. To fill the RLC transmit buffer, run the loopback for [3]s before starting the procedure.
- 8) Reset \hat{I}_{or2} according to tables 10.2.2.2.1.5.2 to 10.2.2.2.1.5.3. The downlink DPCH of cell 2 must remain inactivated.
- 9) UE shall transmit a MEASUREMENT REPORT message triggered by event 1A containing the CFN-SFN time difference between cell 1 and cell 2.
- 10) The downlink DPCH of cell 2 shall be activated.
- 11) The SS shall send an ACTIVE SET UPDATE message, adding cell 2 to the active set.
- 12) The fading simulators are switched on.

10.2.2.2.1.4.2 Procedure

Note: The measurement principle for the missed ACK test (step 3 to 5) and for the false ACK test (step 6 to 9) is as follows. Upon the UE transmission on E-DPCCH and E-DPDCH, the SS responds with E-HICH = ACK or DTX on cell 1 and with NACK (DTX) on cell 2. The UE transmits new data or retransmissions on the corresponding E-DPCCH and E-DPDCH. The SS shall discriminate between:

- (1) new data is a sign for ACK, received by the UE from any of the cells.
- (2) retransmission is a sign for NACK received by the UE on both cells. DTX, received by the UE from cell 1, is interpreted as NACK by higher layer and causes retransmission.

1. The Nominal Avg. Information Bit Rate in the DL is set to 534 kbps according to QPSK H-Set 1. The expected throughput under this level and fading conditions is tested with a single cell in clause 9.2.1, and the DL throughput for this test case will be less than for the single cell case because of interference from Cell 2. The DL throughput for this test case is estimated based on the HSDPA throughput corresponding to the subtests using "HS-PDSCH $E_c/I_{or} = -6\text{dB}$ " condition in 9.2.1A. The UL data rate was configured by signalling AG value 5 on the E-AGCH. The expected UL datarate is 71.6 kbps corresponding to E-TFC Index 45.
2. In the test Missed ACK the SS responds with 100% ACK(1) on cell 1 and 100% NACK(0) on cell 2.
3. If the UE indicates on the the E-DPCCH a retransmission, the ACK from cell 1 was received as NACK by the UE. This is counted as missed(ACK).
If the UE indicates on the the E-DPCCH new data, the ACK from cell 1 was received as ACK by the UE. This is counted as correct ACK.
4. Continue until statistical significance according to Annex F.6.4 is achieved.
5. If the number of retransmissions reaches the maximum number of retransmissions due to several false or missed ACK detections in series, the first new data on the E-DPDCH with E-DPCCH are not the consequence of ACK. This case is not counted as sample.
6. In the test false ACK the SS responds with 100% DTX (0) on cell 1 and with 100% NACK(0) on cell 2.
7. If the UE indicates on the E-DPCCH new data, the DTX from cell 1 was received as ACK by the UE. This is counted as false(ACK).

Note: An ACK reception from cell 2 also causes new data. However, the probability for this event is $< 2\text{E-}4$ according to Tables 10.2.2.1.5.3

If the UE indicates on the E-DPCCH retransmission, then DTX or NACK was received by the UE from cell 1. This is counted as correct reception.

8. Continue until statistical significance according to Annex F.6.4 is achieved.

9. The number of retransmissions will reach the maximum number of retransmissions due to several retransmissions in series. The first new data on the E-DPDCH with E-DPCCH are not the consequence of ACK received by the UE. This case is not counted as sample.

Specific Message Contents

All messages indicated above shall use the same content as described in the default message content in clause 9.2.1 of 34.108 [3] with the following exceptions:

RADIO BEARER SETUP:

Information Element	Value/remark
- RLC PDU size	112
- E-DCH Transmission Time	10 ms
E-DCH MAC-d flow maximum number of retransmissions	15 (max)
E-DCH info	
- Happy bit delay condition	10 ms

ACTIVE SET UPDATE message:

Information Element/Group name	Value/Remark	Version
Message Type (10.2.17)		
UE information elements - RRC transaction identifier - Integrity check info -message authentication code -RRC message sequence number - Activation time - New U-RNTI - New H-RNTI - New Primary E-RNTI - New Secondary E-RNTI	0 SS calculates the value of MAC-I for this message and writes to this IE. The first/ leftmost bit of the bit string contains the most significant bit of the MAC-I. SS provides the value of this IE, from its internal counter. "now". Not Present Not Present Not Present Not Present	Rel-6 Rel-6 Rel-6
CN information elements - CN Information info	Not Present	
Phy CH information elements Uplink radio resources - Maximum allowed UL TX power	33 dBm	
Downlink radio resources - Radio link addition information - Radio link addition information - Primary CPICH info - Primary scrambling code - Downlink DPCH info for each RL	1 Same as adding cell	
- CHOICE mode - Primary CPICH usage for channel estimation - DPCH frame offset - Secondary CPICH info	FDD Primary CPICH may be used This should be reflected by the IE" Cell synchronisation information" in received MEASUREMENT REPORT message Not Present	
- DL channelisation code - Secondary scrambling code - Spreading factor - Code number - Scrambling code change - TPC combination index - Closed loop timing adjustment mode - Downlink F-DPCH info for each RL	Not Present 128 96 No code change 1 Not Present Not Present	
E-HICH Information - Channelisation Code - Signature Sequence	6 1	Rel-6
E-RGCH Information	Not Present	Rel-6
- Radio link removal information - TX Diversity Mode	Not Present Not Present	
Serving HS-DSCH cell information	Not Present	Rel-6
E-DCH reconfiguration information	Not Present	Rel-6

10.2.2.2.1.5 Test requirements

For table 10.2.2.2.1.5.1, the average downlink E- HICH E_c/I_{or} power ratio shall be below the specified value for missed ACK probability in Table 10.2.2.2.1.5.2. For table 10.2.2.2.5.1, the false ACK probability shall be below the specified value in Table 10.2.2.2.1.5.3.

Table 10.2.2.2.1.5.1: Requirement scenario parameters for E-HICH – RLS containing the serving cell in SHO

Parameter	Unit	Missed ACK	False ACK
I_{oc}	dBm/3.84 MHz	-60	
Phase reference	-	P-CPICH	
E-HICH ₁ E_c/I_{or}	dB	-29.6 (test 1)	$-\infty$ (test2,3)
E-HICH ₂ E_c/I_{or}	dB	$-\infty$	
HS-DPSCH ₁ E_c/I_{or}	dB	-2.9(test 1)	-2.9 (test,2,3)
E-HICH signalling pattern for Serving E-DCH cell	-	100% ACK (+1)	100% DTX (0)
E-HICH signalling pattern for cell belonging to RLS not containing the Serving E-DCH cell	-	100% NACK (0)	100% NACK (0)

Table 10.2.2.2.1.5.2: Test requirement for Missed ACK when hybrid ARQ acknowledgement indicator is transmitted using 12 consecutive slots – RLS containing the Serving E-DCH cell

Test Number	Propagation Conditions	Reference value		
		E-HICH E_c/I_{or} (dB) for Serving E-DCH cell (ACK)	\hat{I}_{or1}/I_{oc} and \hat{I}_{or2}/I_{oc} (dB)	Missed ACK probability
1	VA30	-29.6	0.6	0.05

Table 10.2.2.2.1.5.3: Test requirement for False ACK when hybrid ARQ acknowledgement indicator is transmitted using 12 consecutive slots – RLS containing the Serving E-DCH cell

Test Number	Propagation Conditions	Reference value	
		\hat{I}_{or1}/I_{oc} and \hat{I}_{or2}/I_{oc} (dB)	False ACK probability
2	PA3	0.6	0.1
3	VA120	0.6	0.1

To pass the test,

The ratio (missed (ACK) / all valid ACKs, sent) ≤ 0.05 and

The ratio (false (ACK) / (all valid samples)) ≤ 0.1

NOTE: If the above Test Requirement differs from the Minimum Requirement then the Test Tolerance applied for this test is non-zero. The Test Tolerance for this test is defined in clause F.2 and the explanation of how the Minimum Requirement has been relaxed by the Test Tolerance is given in clause F.4.

10.2.2.2.1A RLS containing the Serving E-DCH cell (10ms TTI, Type 1)

10.2.2.2.1A.1 Definition and applicability

The receive characteristics of the E-DCH HARQ ACK Indicator Channel (E-HICH) is determined during an inter-cell soft handover by the missed ACK probabilities. During the soft handover a UE receives signals from different cells. A UE has to be able to detect E-HICH signalling from different cells belonging to different RLS, containing the Serving E-DCH cell.

The requirements and this test apply to Release 7 and later releases for all types of UTRA for the FDD UE that support E-DCH and HSDPA and the optional Type 1 enhanced performance requirements.

10.2.2.2.1A.2 Minimum requirement

For the parameters specified in Table 10.2.2.2.1A.2.1 the average downlink E-HICH E_c/I_{or} power ratio of cell belonging to RLS containing the Serving E-DCH cell shall be below the specified value for the missed ACK probabilities in Table 10.2.2.2.1A.2.2.

Table 10.2.2.2.1A.2.1: Requirement scenario parameters for E-HICH – RLS containing the serving cell in SHO

Parameter	Unit	Missed ACK
I_{oc}	dBm/3.84 MHz	-60
Phase reference	-	P-CPICH
P-CPICH E_c/I_{or} (*)	dB	-10
E-HICH signalling pattern for Serving E-DCH cell	-	100% ACK (+1)
E-HICH signalling pattern for cell belonging to RLS not containing the Serving E-DCH cell	-	100% NACK (0)

Table 10.2.2.2.1A.2.2: Enhanced performance requirement for Missed ACK when hybrid ARQ acknowledgement indicator is transmitted using 12 consecutive slots – RLS containing the Serving E-DCH cell

Test Number	Propagation Conditions	Reference value		
		E-HICH E_c/I_{or} (dB) for Serving E-DCH cell (ACK)	\hat{I}_{or1}/I_{oc} and \hat{I}_{or2}/I_{oc} (dB)	Missed ACK probability
1	VA30	-33.4	0	0.05

The reference for this requirement is TS 25.101 [1] clause 10.2.2.1

10.2.2.2.1A.3 Test purpose

Note: Through all the text below including clause 10.2.2.2.5 the following abbreviation holds: Cell 1: cell belonging to RLS containing the Serving E-DCH cell, Cell 2: cell belonging to RLS not containing the Serving E-DCH cell

To verify that during an inter-cell soft handover for cell 1 the average probability for missed ACK, when E-HICH is transmitted using 12 consecutive slots, does not exceed specified values.

10.2.2.2.1A.4 Method of test

10.2.2.2.1A.4.1 Initial conditions

Test environment: normal; see clauses G.2.1 and G.2.2.

Frequencies to be tested: mid range; see clause G.2.4.

- 1) Connect the SS and AWGN noise source and fading simulators to the UE antenna connector as shown in figure Figure A.24 for UEs that support receive diversity or figure A.11 for UEs that do not support receive diversity.
- 2) The UL Reference Measurement Channel parameters are defined in Annex C.11
- 3) Set the test parameters for the missed ACK test as specified in table 10.2.2.2.1A.5.1 and 10.2.2.2.1A.5.2 and table E.5A.3 with the exception of \hat{I}_{or2} that shall be set to $-\infty$. Set the fading conditions to VA 30.
- 4) The value of Absolute Grant Scope shall be set to 0 and the Absolute Grant shall be set to 5.
- 5) The relative grant is not configured. This ensures that the UL datarate remains constant.
- 6) The UE is switched on.

- 7) Enter the UE into loopback mode 1, looping back both the 12.2kbps RMC and HSDPA to E-DCH, and start the loopback test. See TS 34.108 [3] clause 7.3.9 and TS 34.109 [4] clauses 5.3.2.3 and 5.3.2.6. To fill the RLC transmit buffer, run the loopback for [3]s before starting the procedure.
- 8) Reset \hat{I}_{or2} according to tables 10.2.2.2.1A.5.1 to 10.2.2.2.1A.5.2. The downlink DPCH of cell 2 must remain inactivated.
- 9) UE shall transmit a MEASUREMENT REPORT message triggered by event 1A containing the CFN-SFN time difference between cell 1 and cell 2.
- 10) The downlink DPCH of cell 2 shall be activated.
- 11) The SS shall send an ACTIVE SET UPDATE message, adding cell 2 to the active set.
- 12) The fading simulators are switched on.

10.2.2.2.1A.4.2 Procedure

Note: The measurement principle for the missed ACK test (step 3 to 5) is as follows. Upon the UE transmission on E-DPCCH and E-DPDCH, the SS responds with E-HICH = ACK on cell 1 and with NACK (DTX) on cell 2. The UE transmits new data or retransmissions on the corresponding E-DPCCH and E-DPDCH. The SS shall discriminate between:

- (1) new data is a sign for ACK, received by the UE from any of the cells.
- (2) retransmission is a sign for NACK received by the UE on both cells. DTX, received by the UE from cell 1, is interpreted as NACK by higher layer and causes retransmission.

1. The Nominal Avg. Information Bit Rate in the DL is set to 534 kbps according to QPSK H-Set 1. The expected throughput under this level and fading conditions is tested with a single cell in clause 9.2.1 and the DL throughput for this test case will be less than for the single cell case because of interference from Cell 2. The DL throughput for this test case is estimated based on the HSDPA throughput corresponding to the subtests using "HS-PDSCH $E_c/I_{or} = -6\text{dB}$ " condition in 9.2.1A. The UL data rate was configured by signalling AG value 5 on the E-AGCH. The expected UL data rate is 71.6 kbps corresponding to E-TFC Index 45.
2. In the test Missed ACK the SS responds with 100% ACK(1) on cell 1 and 100% NACK(0) on cell 2.
3. If the UE indicates on the E-DPCCH a retransmission, the ACK from cell 1 was received as NACK by the UE. This is counted as missed(ACK).
If the UE indicates on the E-DPCCH new data, the ACK from cell 1 was received as ACK by the UE. This is counted as correct ACK.
4. Continue until statistical significance according to Annex F.6.4 is achieved.
5. If the number of retransmissions reaches the maximum number of retransmissions due to several false or missed ACK detections in series, the first new data on the E-DPDCH with E-DPCCH are not the consequence of ACK. This case is not counted as sample.

Specific Message Contents

All messages indicated above shall use the same content as described in the default message content in clause 9.2.1 of 34.108 [3] with the following exceptions:

RADIO BEARER SETUP:

Information Element	Value/remark
- RLC PDU size	112
- E-DCH Transmission Time	10 ms
E-DCH MAC-d flow maximum number of retransmissions	15 (max)
E-DCH info	
- Happy bit delay condition	10 ms

ACTIVE SET UPDATE message:

Information Element/Group name	Value/Remark	Version
Message Type (10.2.17)		
UE information elements - RRC transaction identifier - Integrity check info - message authentication code - RRC message sequence number - Activation time - New U-RNTI - New H-RNTI - New Primary E-RNTI - New Secondary E-RNTI	0 SS calculates the value of MAC-I for this message and writes to this IE. The first/ leftmost bit of the bit string contains the most significant bit of the MAC-I. SS provides the value of this IE, from its internal counter. "now". Not Present Not Present Not Present Not Present	Rel-6 Rel-6 Rel-6
CN information elements - CN Information info	Not Present	
Phy CH information elements Uplink radio resources - Maximum allowed UL TX power	33 dBm	
Downlink radio resources - Radio link addition information - Radio link addition information - Primary CPICH info - Primary scrambling code - Downlink DPCH info for each RL	1 Same as adding cell	
- CHOICE mode - Primary CPICH usage for channel estimation - DPCH frame offset - Secondary CPICH info	FDD Primary CPICH may be used This should be reflected by the IE" Cell synchronisation information" in received MEASUREMENT REPORT message Not Present	
- DL channelisation code - Secondary scrambling code - Spreading factor - Code number - Scrambling code change - TPC combination index - Closed loop timing adjustment mode - Downlink F-DPCH info for each RL	Not Present 128 96 No code change 1 Not Present Not Present	
E-HICH Information - Channelisation Code - Signature Sequence	6 1	Rel-6
E-RGCH Information	Not Present	Rel-6
- Radio link removal information - TX Diversity Mode	Not Present Not Present	
Serving HS-DSCH cell information	Not Present	Rel-6
E-DCH reconfiguration information	Not Present	Rel-6

10.2.2.2.1A.5 Test requirements

For table 10.2.2.2.1A.5.1, the average downlink E- HICH E_c/I_{0r} power ratio shall be below the specified value for missed ACK probability in Table 10.2.2.2.1A.5.2

Table 10.2.2.2.1A.5.1: Requirement scenario parameters for E-HICH – RLS containing the serving cell in SHO

Parameter	Unit	Missed ACK
I_{oc}	dBm/3.84 MHz	-60
Phase reference	-	P-CPICH
E-HICH ₁ E_c/I_{or}	dB	-33.3 (test 1)
E-HICH ₂ E_c/I_{or}	dB	$-\infty$
HS-DPSCH ₁ E_c/I_{or}	dB	-2.9(test 1)
E-HICH signalling pattern for Serving E-DCH cell	-	100% ACK (+1)
E-HICH signalling pattern for cell belonging to RLS not containing the Serving E-DCH cell	-	100% NACK (0)

Table 10.2.2.2.1A.5.2: Test requirement Type 1 for Missed ACK when hybrid ARQ acknowledgement indicator is transmitted using 12 consecutive slots – RLS containing the Serving E-DCH cell

Test Number	Propagation Conditions	Reference value		
		E-HICH E_c/I_{or} (dB) for Serving E-DCH cell (ACK)	\hat{I}_{or1}/I_{oc} and \hat{I}_{or2}/I_{oc} (dB)	Missed ACK probability
1	VA30	-33.3	0.6	0.05

To pass the test,

The ratio (missed (ACK) / all valid ACKs, sent) ≤ 0.05

NOTE: If the above Test Requirement differs from the Minimum Requirement then the Test Tolerance applied for this test is non-zero. The Test Tolerance for this test is defined in clause F.2 and the explanation of how the Minimum Requirement has been relaxed by the Test Tolerance is given in clause F.4.

10.2.2.2.2 RLS containing the Serving E-DCH cell (2ms TTI)

10.2.2.2.2.1 Definition and applicability

The receive characteristics of the E-DCH HARQ ACK Indicator Channel (E-HICH) is determined during an inter-cell soft handover by the missed ACK and false ACK error probabilities. During the soft handover a UE receives signals from different cells. A UE has to be able to detect E-HICH signalling from different cells belonging to different RLS, containing the Serving E-DCH cell.

The requirements and this test apply to Release 6 and later releases for all types of UTRA for the FDD UE that support E-DCH with 2ms TTI and HSDPA.

10.2.2.2.2.2 Minimum requirement

For the parameters specified in Table 10.2.2.2.2.1 the average downlink E-HICH E_c/I_{or} power ratio of cell belonging to RLS containing the Serving E-DCH cell shall be below the specified value for the missed ACK probabilities in Table 10.2.2.2.2.2. For the parameters specified in Table 10.2.2.2.2.1 the false ACK probability shall be below the specified value in Table 10.2.2.2.2.3

Table 10.2.2.2.2.1: Requirement scenario parameters for E-HICH – RLS containing the serving cell in SHO

Parameter	Unit	Missed ACK	False ACK
I_{oc}	dBm/3.84 MHz	-60	
Phase reference	-	P-CPICH	
P-CPICH E_c/I_{or} (*)	dB	-10	
E-HICH signalling pattern for Serving E-DCH cell	-	100% ACK (+1)	100% DTX (0)
E-HICH signalling pattern for cell belonging to RLS not containing the Serving E-DCH cell	-	100% NACK (0)	100% NACK (0)

Table 10.2.2.2.2.2: Minimum requirement for Missed ACK when hybrid ARQ acknowledgement indicator is transmitted using 3 consecutive slots – RLS containing the Serving E-DCH cell

Test Number	Propagation Conditions	Reference value		
		E-HICH E_c/I_{or} (dB) for Serving E-DCH cell (ACK)	\hat{I}_{or1}/I_{oc} and \hat{I}_{or2}/I_{oc} (dB)	Missed ACK probability
1	VA30	-23.2	0	0.05

Table 10.2.2.2.2.3: Minimum requirement for False ACK when hybrid ARQ acknowledgement indicator is transmitted using 3 consecutive slots – RLS containing the Serving E-DCH cell

Test Number	Propagation Conditions	Reference value	
		\hat{I}_{or1}/I_{oc} and \hat{I}_{or2}/I_{oc} (dB)	False ACK probability
2	PA3	0	0.1
3	VA120	0	0.1

The reference for this requirement is TS 25.101 [1] clause 10.2.2.1

10.2.2.2.2.3 Test purpose

Note: Through all the text below including clause 10.2.2.2.5 the following abbreviation holds: Cell 1: cell belonging to RLS containing the Serving E-DCH cell, Cell 2: cell belonging to RLS not containing the Serving E-DCH cell

To verify that during an inter-cell soft handover for cell 1 the average probability for missed ACK and the average probability for false ACK, when E-HICH is transmitted using 3 consecutive slots, does not exceed specified values.

10.2.2.2.2.4 Method of test

10.2.2.2.2.4.1 Initial conditions

Test environment: normal; see clauses G.2.1 and G.2.2.

Frequencies to be tested: mid range; see clause G.2.4.

- 1) Connect the SS and AWGN noise source and fading simulators to the UE antenna connector as shown in figure Figure A.11.
- 2) The UL Reference Measurement Channel parameters are defined in Annex C.11.
- 3) Set the test parameters for the missed ACK and false ACK test as specified in table 10.2.2.2.2.5.1 to 10.2.2.2.2.5.3 and table E.5A.3, with the exception of \hat{I}_{or2} that shall be set to $-\infty$. Set the fading conditions to VA 30, PA3 or VA 120.
- 4) The value of Absolute Grant Scope shall be set to 0, and the Absolute Grant shall be set to 3.

- 5) The relative grant is not configured. This ensures that the UL datarate remains constant.
- 6) The UE is switched on.
- 7) Enter the UE into loopback mode 1, looping back both the 12.2kbps RMC and HSDPA to E-DCH, and start the loopback test. See TS 34.108 [3] clause 7.3.9 and TS 34.109 [4] clauses 5.3.2.3 and 5.3.2.6. To fill the RLC transmit buffer, run the loopback for [3]s before starting the procedure.
- 8) Reset \hat{I}_{or2} according to tables 10.2.2.2.2.5.2 to 10.2.2.2.2.5.3. The downlink DPCH of cell 2 must remain inactivated.
- 9) UE shall transmit a MEASUREMENT REPORT message triggered by event 1A containing the CFN-SFN time difference between cell 1 and cell 2.
- 10) The downlink DPCH of cell 2 shall be activated.
- 11) The SS shall send an ACTIVE SET UPDATE message, adding cell 2 to the active set.
- 12) The fading simulators are switched on.

10.2.2.2.4.2 Procedure

Note: The measurement principle for the missed ACK test (step 2 to 5) and for the false ACK test (step 6 to 9) is as follows. Upon the UE transmission on E-DPCCH and E-DPDCH, the SS responds with E-HICH = ACK or DTX on cell 1 and with DTX on cell 2. The UE transmits new data or retransmissions on the corresponding E-DPCCH and E-DPDCH. The SS shall discriminate between:

- (1) new data is a sign for ACK, received by the UE from any of the cells.
- (2) retransmission is a sign for NACK received by the UE on both cells. DTX, received by the UE from cell 1, is interpreted as NACK by higher layer and causes retransmission.

1. The Nominal Avg. Information Bit Rate in the DL is set to 534 kbps according to QPSK H-Set 1. The expected throughput under this level and fading conditions is tested with a single cell in clause 9.2.1, and the DL throughput for this test case will be less than for the single cell case because of interference from Cell 2. The DL throughput for this test case is estimated based on the HSDPA throughput corresponding to the subtests using "HS-PDSCH $E_c/I_{or} = -6\text{dB}$ " condition in 9.2.1A. The UL data rate was configured by signalling AG value 3 on the E-AGCH. The expected UL datarate is 123.5 kbps corresponding to E-TFC Index 21.
2. In the test Missed ACK the SS responds with 100% ACK(1) on cell 1 and 100% NACK(0) on cell 2.
3. If the UE indicates on the the E-DPCCH a retransmission, the ACK from cell 1 was received as NACK by the UE. This is counted as missed(ACK).

If the UE indicates on the the E-DPCCH new data, the ACK from cell 1 was received as ACK by the UE. This is counted as correct ACK.
4. Continue until statistical significance according to Annex F.6.4 is achieved.
5. If the number of retransmissions reaches the maximum number of retransmissions due to several false or missed ACK detections in series, the first new data on the E-DPDCH with E-DPCCH are not the consequence of ACK. This case is not counted as sample.
6. In the test false ACK the SS responds with 100% DTX (0) on cell 1 and with 100% NACK(0) on cell 2.
7. If the UE indicates on the E-DPCCH new data, the DTX from cell 1 was received as ACK by the UE. This is counted as false(ACK).

Note: An ACK reception from cell 2 also causes new data. However, the probability for this event is $< 2\text{E-}4$ according to Table 10.2.2.1.2.2.3:

If the UE indicates on the E-DPCCH retransmission, then DTX or NACK was received by the UE from cell 1. This is counted as correct reception.

8. Continue until statistical significance according to Annex F.6.4 is achieved.

9. The number of retransmissions will reach the maximum number of transmissions due to several retransmissions in series. The first new data on the E-DPDCH with E-DPCCH are not the consequence of ACK received by the UE. This case is not counted as sample.

Specific Message Contents

All messages indicated above shall use the same content as described in the default message content in clause 9.2.1 of 34.108 [3] with the following exceptions:

RADIO BEARER SETUP:

Information Element	Value/remark
- RLC PDU size	112
- E-DCH Transmission Time	2ms
E-DCH MAC-d flow maximum number of retransmissions	15 (max)
E-DCH info	
- Happy bit delay condition	2ms

ACTIVE SET UPDATE message:

Information Element/Group name	Value/Remark	Version
Message Type (10.2.17)		
UE information elements - RRC transaction identifier - Integrity check info -message authentication code -RRC message sequence number - Activation time - New U-RNTI - New H-RNTI - New Primary E-RNTI - New Secondary E-RNTI	0 SS calculates the value of MAC-I for this message and writes to this IE. The first/ leftmost bit of the bit string contains the most significant bit of the MAC-I. SS provides the value of this IE, from its internal counter. "now". Not Present Not Present Not Present Not Present	 Rel-6 Rel-6 Rel-6
CN information elements - CN Information info	Not Present	
Phy CH information elements Uplink radio resources - Maximum allowed UL TX power	33 dBm	
Downlink radio resources - Radio link addition information - Radio link addition information - Primary CPICH info - Primary scrambling code - Downlink DPCH info for each RL	1 Same as adding cell	
- CHOICE mode - Primary CPICH usage for channel estimation - DPCH frame offset - Secondary CPICH info	FDD Primary CPICH may be used This should be reflected by the IE" Cell synchronisation information" in received MEASUREMENT REPORT message Not Present	
- DL channelisation code - Secondary scrambling code - Spreading factor - Code number - Scrambling code change - TPC combination index - Closed loop timing adjustment mode - Downlink F-DPCH info for each RL	Not Present 128 96 No code change 1 Not Present Not Present	
E-HICH Information - Channelisation Code - Signature Sequence	6 1	Rel-6
E-RGCH Information	Not Present	Rel-6
- Radio link removal information - TX Diversity Mode	Not Present Not Present	
Serving HS-DSCH cell information	Not Present	Rel-6
E-DCH reconfiguration information	Not Present	Rel-6

10.2.2.2.5.5 Test requirements

For table 10.2.2.2.5.1, the average downlink E- HICH E_c/I_{or} power ratio shall be below the specified value for missed ACK probability in Table 10.2.2.2.5.2. For table 10.2.2.2.5.1, the false ACK probability shall be below the specified value in Table 10.2.2.2.5.3.

Table 10.2.2.2.5.1: Requirement scenario parameters for E-HICH – RLS containing the serving cell in SHO

Parameter	Unit	Missed ACK	False ACK
I_{oc}	dBm/3.84 MHz	-60	
Phase reference	-	P-CPICH	
E-HICH ₁ E_c/I_{or}	dB	-23.1 (test 1)	$-\infty$ (test 2,3)
E-HICH ₂ E_c/I_{or}	dB	$-\infty$	
HS-DPSCH ₁ E_c/I_{or}	dB	-2.9(test 1)	-2.9 (test 2,3)
E-HICH signalling pattern for Serving E-DCH cell	-	100% ACK (+1)	100% DTX (0)
E-HICH signalling pattern for cell belonging to RLS not containing the Serving E-DCH cell	-	100% NACK (0)	100% NACK (0)

Table 10.2.2.2.5.2: Test requirement for Missed ACK when hybrid ARQ acknowledgement indicator is transmitted using 3 consecutive slots – RLS containing the Serving E-DCH cell

Test Number	Propagation Conditions	Reference value		
		E-HICH E_c/I_{or} (dB) for Serving E-DCH cell (ACK)	\hat{I}_{or1}/I_{oc} and \hat{I}_{or2}/I_{oc} (dB)	Missed ACK probability
1	VA30	-23.1	0.6	0.05

Table 10.2.2.2.5.3: Test requirement for False ACK when hybrid ARQ acknowledgement indicator is transmitted using 3 consecutive slots – RLS containing the Serving E-DCH cell

Test Number	Propagation Conditions	Reference value	
		\hat{I}_{or1}/I_{oc} and \hat{I}_{or2}/I_{oc} (dB)	False ACK probability
2	PA3	0.6	0.1
3	VA120	0.6	0.1

To pass the test,

The ratio (missed (ACK) / all valid ACKs, sent) ≤ 0.05 and

The ratio (false (ACK) / (all valid samples)) ≤ 0.1

NOTE: If the above Test Requirement differs from the Minimum Requirement then the Test Tolerance applied for this test is non-zero. The Test Tolerance for this test is defined in clause F.2 and the explanation of how the Minimum Requirement has been relaxed by the Test Tolerance is given in clause F.4.

10.2.2.2.2A RLS containing the Serving E-DCH cell (2ms TTI, Type 1)

10.2.2.2.2A.1 Definition and applicability

The receive characteristics of the E-DCH HARQ ACK Indicator Channel (E-HICH) is determined during an inter-cell soft handover by the missed ACK error probabilities. During the soft handover a UE receives signals from different cells. A UE has to be able to detect E-HICH signalling from different cells belonging to different RLS, containing the Serving E-DCH cell.

The requirements and this test apply to Release 7 and later releases for all types of UTRA for the FDD UE that support E-DCH with 2ms TTI and HSDPA and the optional Type 1 enhanced performance requirements.

10.2.2.2.2A.2 Minimum requirement

For the parameters specified in Table 10.2.2.2.2A.2.1 the average downlink E-HICH E_c/I_{or} power ratio of cell belonging to RLS containing the Serving E-DCH cell shall be below the specified value for the missed ACK probabilities in Table 10.2.2.2.2A.2.2.

Table 10.2.2.2A.2.1: Requirement scenario parameters for E-HICH – RLS containing the serving cell in SHO

Parameter	Unit	Missed ACK
I_{oc}	dBm/3.84 MHz	-60
Phase reference	-	P-CPICH
P-CPICH E_c/I_{or} (*)	dB	-10
E-HICH signalling pattern for Serving E-DCH cell	-	100% ACK (+1)
E-HICH signalling pattern for cell belonging to RLS not containing the Serving E-DCH cell	-	100% NACK (0)

Table 10.2.2.2A.2.2: Enhanced performance requirement for Missed ACK when hybrid ARQ acknowledgement indicator is transmitted using 3 consecutive slots – RLS containing the Serving E-DCH cell

Test Number	Propagation Conditions	Reference value		
		E-HICH E_c/I_{or} (dB) for Serving E-DCH cell (ACK)	\hat{I}_{or1}/I_{oc} and \hat{I}_{or2}/I_{oc} (dB)	Missed ACK probability
1	VA30	-27.1	0	0.05

The reference for this requirement is TS 25.101 [1] clause 10.2.2.1

10.2.2.2A.3 Test purpose

Note: Through all the text below including clause 10.2.2.2.5 the following abbreviation holds: Cell 1: cell belonging to RLS containing the Serving E-DCH cell, Cell 2: cell belonging to RLS not containing the Serving E-DCH cell

To verify that during an inter-cell soft handover for cell 1 the average probability for missed ACK, when E-HICH is transmitted using 3 consecutive slots, does not exceed specified values.

10.2.2.2A.4 Method of test

10.2.2.2A.4.1 Initial conditions

Test environment: normal; see clauses G.2.1 and G.2.2.

Frequencies to be tested: mid range; see clause G.2.4.

- 1) Connect the SS and AWGN noise source and fading simulators to the UE antenna connector as shown in figure Figure A.24 for UEs that support receive diversity or figure A.10 for UEs that do not support receive diversity.
- 2) The UL Reference Measurement Channel parameters are defined in Annex C.11
- 3) Set the test parameters for the missed ACK test as specified in table 10.2.2.2A.5.1 and 10.2.2.2A.5.2 and table E.5A.3 with the exception of \hat{I}_{or2} that shall be set to $-\infty$. Set the fading conditions to VA 30.
- 4) The value of Absolute Grant Scope shall be set to 0, and the Absolute Grant shall be set to 3.
- 5) The relative grant is not configured. This ensures that the UL datarate remains constant.
- 6) The UE is switched on.
- 7) Enter the UE into loopback mode 1, looping back both the 12.2kbps RMC and HSDPA to E-DCH, and start the loopback test. See TS 34.108 [3] clause 7.3.9 and TS 34.109 [4] clauses 5.3.2.3 and 5.3.2.6. To fill the RLC transmit buffer, run the loopback for [3]s before starting the procedure.

- 8) Reset \hat{I}_{or2} according to tables 10.2.2.2A.5.1 to 10.2.2.2A.5.2. The downlink DPCH of cell 2 must remain inactivated.
- 9) UE shall transmit a MEASUREMENT REPORT message triggered by event 1A containing the CFN-SFN time difference between cell 1 and cell 2.
- 10) The downlink DPCH of cell 2 shall be activated.
- 11) The SS shall send an ACTIVE SET UPDATE message, adding cell 2 to the active set.
- 12) The fading simulators are switched on.

10.2.2.2A.4.2 Procedure

Note: The measurement principle for the missed ACK test (step 2 to 5) is as follows. Upon the UE transmission on E-DPCCH and E-DPDCH, the SS responds with E-HICH = ACK on cell 1 and with DTX on cell 2. The UE transmits new data or retransmissions on the corresponding E-DPCCH and E-DPDCH. The SS shall discriminate between:

- (1) new data is a sign for ACK, received by the UE from any of the cells.
 - (2) retransmission is a sign for NACK received by the UE on both cells. DTX, received by the UE from cell 1, is interpreted as NACK by higher layer and causes retransmission.
1. The Nominal Avg. Information Bit Rate in the DL is set to 534 kbps according to QPSK H-Set 1. The expected throughput under this level and fading conditions is tested with a single cell in clause 9.2.1 and the DL throughput for this test case will be less than for the single cell case because of interference from Cell 2. The DL throughput for this test case is estimated based on the HSDPA throughput corresponding to the subtests using "HS-PDSCH Ec/Ior = -6dB" condition in 9.2.1A. The UL data rate was configured by signalling AG value 3 on the E-AGCH. The expected UL datarate is 123.5 kbps corresponding to E-TFC Index 21.
 2. In the test Missed ACK the SS responds with 100% ACK(1) on cell 1 and 100% NACK(0) on cell 2.
 3. If the UE indicates on the the E-DPCCH a retransmission, the ACK from cell 1 was received as NACK by the UE. This is counted as missed(ACK).

If the UE indicates on the the E-DPCCH new data, the ACK from cell 1 was received as ACK by the UE. This is counted as correct ACK.
 4. Continue until statistical significance according to Annex F.6.4 is achieved.
 5. If the number of retransmissions reaches the maximum number of retransmissions due to several false or missed ACK detections in series, the first new data on the E-DPDCH with E-DPCCH are not the consequence of ACK. This case is not counted as sample.

Specific Message Contents

All messages indicated above shall use the same content as described in the default message content in clause 9.2.1 of 34.108 [3] with the following exceptions:

RADIO BEARER SETUP:

Information Element	Value/remark
- RLC PDU size	112
- E-DCH Transmission Time	2ms
E-DCH MAC-d flow maximum number of retransmissions	15 (max)
E-DCH info	
- Happy bit delay condition	2ms

ACTIVE SET UPDATE message:

Information Element/Group name	Value/Remark	Version
Message Type (10.2.17)		
UE information elements - RRC transaction identifier - Integrity check info -message authentication code -RRC message sequence number - Activation time - New U-RNTI - New H-RNTI - New Primary E-RNTI - New Secondary E-RNTI	0 SS calculates the value of MAC-I for this message and writes to this IE. The first/ leftmost bit of the bit string contains the most significant bit of the MAC-I. SS provides the value of this IE, from its internal counter. "now". Not Present Not Present Not Present Not Present	 Rel-6 Rel-6 Rel-6
CN information elements - CN Information info	Not Present	
Phy CH information elements Uplink radio resources - Maximum allowed UL TX power	33 dBm	
Downlink radio resources - Radio link addition information - Radio link addition information - Primary CPICH info - Primary scrambling code - Downlink DPCH info for each RL	1 Same as adding cell	
- CHOICE mode - Primary CPICH usage for channel estimation - DPCH frame offset - Secondary CPICH info	FDD Primary CPICH may be used This should be reflected by the IE" Cell synchronisation information" in received MEASUREMENT REPORT message Not Present	
- DL channelisation code - Secondary scrambling code - Spreading factor - Code number - Scrambling code change - TPC combination index - Closed loop timing adjustment mode - Downlink F-DPCH info for each RL	Not Present 128 96 No code change 1 Not Present Not Present	
E-HICH Information - Channelisation Code - Signature Sequence	6 1	Rel-6
E-RGCH Information	Not Present	Rel-6
- Radio link removal information - TX Diversity Mode	Not Present Not Present	
Serving HS-DSCH cell information	Not Present	Rel-6
E-DCH reconfiguration information	Not Present	Rel-6

10.2.2.2.A.5 Test requirements

For table 10.2.2.2.A.5.1, the average downlink E- HICH E_c/I_{0r} power ratio shall be below the specified value for missed ACK probability in Table 10.2.2.2.A.5.2.

Table 10.2.2.2A.5.1: Requirement scenario parameters for E-HICH – RLS containing the serving cell in SHO

Parameter	Unit	Missed ACK
I_{oc}	dBm/3.84 MHz	-60
Phase reference	-	P-CPICH
E-HICH ₁ E_c/I_{or}	dB	-27.0 (test 1)
E-HICH ₂ E_c/I_{or}	dB	$-\infty$
HS-DPSCH ₁ E_c/I_{or}	dB	-2.9(test 1)
E-HICH signalling pattern for Serving E-DCH cell	-	100% ACK (+1)
E-HICH signalling pattern for cell belonging to RLS not containing the Serving E-DCH cell	-	100% NACK (0)

Table 10.2.2.2A.5.2: Test requirement Type 1 for Missed ACK when hybrid ARQ acknowledgement indicator is transmitted using 3 consecutive slots – RLS containing the Serving E-DCH cell

Test Number	Propagation Conditions	Reference value		
		E-HICH E_c/I_{or} (dB) for Serving E-DCH cell (ACK)	\hat{I}_{or1}/I_{oc} and \hat{I}_{or2}/I_{oc} (dB)	Missed ACK probability
1	VA30	-27.0	0.6	0.05

To pass the test,

The ratio (missed (ACK) / all valid ACKs, sent) ≤ 0.05

NOTE: If the above Test Requirement differs from the Minimum Requirement then the Test Tolerance applied for this test is non-zero. The Test Tolerance for this test is defined in clause F.2 and the explanation of how the Minimum Requirement has been relaxed by the Test Tolerance is given in clause F.4.

10.3 Detection of E-DCH Relative Grant Channel (E-RGCH)

10.3.1 Single link performance

10.3.1.1 Single link performance (10ms TTI)

10.3.1.1.1 Definition and applicability

The receive characteristics of the E-DCH Relative Grant Channel (E-RGCH) in multi-path fading environment is determined by the missed UP/DOWN and missed HOLD. The requirements and this test apply to Release 6 and later releases for all types of UTRA for the FDD UE that support E-DCH and HSDPA.

Note: The fail cases for Up are Down (erroneous detection) and Hold (missed detection).

The fail cases for Down are Up and Hold. TS 25.101 designated this test "Missed Up/Down". It is assumed that the minimum requirements apply for both fail cases erroneous and missed detection.

10.3.1.1.2 Minimum requirement

For the parameters specified in Table 10.3.1.1.2.1 the average downlink E-RGCH E_c/I_{or} power ratio shall be below the specified value for the missed UP/DOWN probabilities in Table 10.3.1.1.2.2. For the parameters specified in Table 10.3.1.1.2.1 the missed HOLD probability shall be below the specified value in Table 10.3.1.1.2.

Table 10.3.1.1.2.1: Parameters for E-RGCH – Serving E-DCH cell

Parameter	Unit	Missed UP/DOWN	Missed HOLD
I_{oc}	dBm/3.84 MHz	-60	
Phase reference	-	P-CPICH	
P-CPICH E_c/I_{or}	dB	-10	
E-RGCH signalling pattern	-	50% UP 50% DOWN	100% HOLD

Table 10.3.1.1.2.2: Minimum requirement for Missed UP/DOWN when relative scheduling grant is transmitted using 12 consecutive slots – Serving E-DCH cell

Test Number	Propagation Conditions	Reference value		
		E-RGCH E_c/I_{or} (dB)	\hat{I}_{or}/I_{oc} (dB)	Missed UP/DOWN probability
1	VA30	-31	0	0.05/0.05

Table 10.3.1.1.2.3: Minimum requirement for Missed HOLD when relative scheduling grant is transmitted using 12 consecutive slots – Serving E-DCH cell

Test Number	Propagation Conditions	Reference value	
		\hat{I}_{or}/I_{oc} (dB)	Missed HOLD probability
2	VA30	0	0.1

The reference for this requirement is TS 25.101 [1] clause 10.3.1

10.3.1.1.3 Test purpose

To verify that average probability for missed up down and average probability for missed hold, when E-RGCH is transmitted using 12 consecutive slots, do not exceed specified values.

10.3.1.1.4 Method of test

10.3.1.1.4.1 Initial conditions

Test environment: normal; see clauses G.2.1 and G.2.2.

Frequencies to be tested: mid range; see clause G.2.4.

- 1) Connect the SS and AWGN noise source and fading simulator to the UE antenna connector as shown in figure Figure A.10.
- 2) The UL Reference Measurement Channel parameters are defined in Annex C.11
- 3) Set the test parameters for the missed up down test and the missed hold test as specified in table 10.3.1.1.5.1. to 10.3.1.1.5.3 and table E.5A.2. Set the fading conditions to VA 30
- 4) The value of Absolute Grant Scope shall be set to the 0. and the Absolute Grant shall be set to 5
- 5) The UE is switched on.
- 6) Enter the UE into loopback mode 1, looping back both the 12.2kbps RMC and HSDPA to E-DCH, and start the loopback test. See TS 34.108 [3] clause 7.3.9 and TS 34.109 [4] clauses 5.3.2.3 and 5.3.2.6. To fill the RLC transmit buffer, run the loopback for [3]s before starting the procedure.
- 7) The fading simulator is switched on.

10.3.1.1.4.2 Procedure

Note: The measurement principle for the missed up down test (step 3 to 10) and for the missed hold test (step 11 to 15) is as follows. The UE transmits E-DPCCH and E-DPDCH. The SS transmits E-RGCH up or down or hold (DTX). The UE changes or holds the transport format of the corresponding E-DPCCH and E-DPDCH accordingly. This is visible for the SS by reading the E-TFCI, signalled on the corresponding E-DPCCH.

- 1) The Nominal Avg. Information Bit Rate in the DL is set to 534 kbps according to QPSK H-Set 1. The expected throughput under this level and fading conditions is 142 kbps. The expected UL datarate is 71.6 kbps corresponding to E-TFC Index 45.
- 2) Upon reception of every E-DPCCH and E-DPDCH, the SS signals always “DTX” on the E-HICH during the entire test. This way there is no E_HICH power. Nevertheless the UE will transmit new data, since “E-DCH MAC-d flow maximum number of retransmissions” is set to 0.
- 3) The SS signals 4 consecutive “down” on the E-RGCH
- 4) The SS reads the E-TFCI for 4 consecutive HARQ processes, signalled on the E-DPCCH, corresponding to these “down”
- 5) If the UE increases or holds the transport format at each HARQ process upon a “down” command, count a missed(down).

If the UE signals Happy Bit = 1, the UE may transmit less data than granted. (TS25.321 [13] section 11.8.1.5. bullet point 1) The corresponding E-DPCCH and E-DPDCH TTI is not counted as sample.

- 6) The SS signals 4 consecutive “up” on the E-RGCH
- 7) The SS reads the E-TFCI for 4 consecutive HARQ processes, signalled on the E-DPCCH corresponding to these “up”.
- 8) If the UE decreases or holds the transport format at each HARQ process upon an “up” command, count a missed(up).

If the UE signals Happy Bit = 1, the UE may transmit less data than granted. (TS25.321 [13] section 11.8.1.5. bullet point 1) The corresponding E-DPCCH and E-DPDCH TTI is not counted as sample.

- 9) Repeat the “down-up” cycle in step 3 to 8, such that statistical significance according to Annex F.6.4 is achieved for up and down separately.

Due to missed up or missed down the operating range will shift down or up. If the operating range shifts outside the range shown in Table 10.3.1.1.4.2.1 the operating range must be re-adjusted.

Table 10.3.1.1.4.2.1 E-TFCI operating point/range(10 ms)

missed up down	missed hold	AG Value	β_{ed}/β_c	E-TFCI	TB Size=N*112 + Header + Padding	UL rate kbps
		6	24/15	59	1264 = 11*112 + 18 + 14	126.4
			21/15	52	951 = 8*112 + 18 + 37	95.1
Initial operating range	Initial operating point	5	19/15	45	716 = 6*112 + 18 + 26	71.6
			17/15	40	584 = 5*112 + 18 + 6	58.4
		4	15/15	35	477 = 4*112 + 18 + 11	47.7
			13/15	28	359 = 3*112 + 18 + 4	35.9
			12/15	19	249 = 2*112 + 18 + 7	24.9

- 10) If one counter reaches the pass criterion, this counter is stopped and the remaining counter is continued. The missed up down test is decided pass, if the last counter reaches pass. The missed up down test is decided fail, if the first counter reaches fail.

- 11) Hold on E-RGCH is indicated by DTX from the SS.

- 12) The SS signals “DTX” on the E-RGCH

13)The SS reads the E-TFCI, signalled on the E-DPCCH corresponding to that “DTX”.

14)If the UE increases or decreases the transport format upon a “DTX” command, record a missed(hold).

If the UE signals Happy Bit = 1, the UE may transmit less data than granted. (TS25.321 [13] section 11.8.1.5. bullet point 1) The corresponding E-DPCCH and E-DPDCH TTI is not counted as sample.

15)Repeat step 11 to 14, such that statistical significance according to Annex F.6.4 is achieved.

Due to missed hold the operating range will shift down or up. If the operating range shifts outside the range shown in Table 10.3.1.1.4.2.1 the operating range must be re-adjusted.

Specific Message Contents

All messages indicated above shall use the same content as described in the default message content in clause 9.2.1 of 34.108 [3] with the following exceptions:

RADIO BEARER SETUP:

Information Element	Value/remark	Version
RLC PDU size	112	Rel-6
- E-DCH Transmission Time	10 ms	
E-DCH MAC-d flow maximum number of retransmissions	0	
E-DCH info		Rel-6
- Happy bit delay condition	10 ms (indication of exhausted resources on frame basis)	
- E-DCH minimum set E-TFCI	Not Present in RGCH performance tests, all E-TFCs should be in the selection process)	
Downlink information for each radio link list		
- Downlink information for each radio link		
- CHOICE E-RGCH Information		Rel-6
- E-RGCH Information		
- Signature Sequence	0	
- RG combination index	0	

10.3.1.1.5 Test requirements

Table 10.3.1.1.5.1: Test Parameters for E-RGCH – Serving E-DCH cell

Parameter	Unit	Missed UP/DOWN	Missed HOLD
I_{oc}	dBm/3.84 MHz	-60	
Phase reference	-	P-CPICH	
E-RGCH E_c/I_{or}	dB	-30.9 (test 1)	$-\infty$ (test 2)
E-RGCH signalling pattern	-	50% UP 50% DOWN	100% HOLD

Table 10.3.1.1.5.2: Test requirement for Missed UP/DOWN when relative scheduling grant is transmitted using 12 consecutive slots – Serving E-DCH cell

Test Number	Propagation Conditions	Reference value		
		E-RGCH E_c/I_{or} (dB)	\hat{I}_{or}/I_{oc} (dB)	Missed UP/DOWN probability
1	VA30	-30.9	0.6	0.05/0.05

Table 10.3.1.1.5.3: Test requirement for Missed HOLD when relative scheduling grant is transmitted using 12 consecutive slots – Serving E-DCH cell

Test Number	Propagation Conditions	Reference value	
		\hat{I}_{or} / I_{oc} (dB)	Missed HOLD probability
2	VA30	0.6	0.1

To pass the test,

the ratio (missed(down) / all valid down commands, sent) ≤ 0.05 and

the ratio (missed(up) / all valid up commands, sent) ≤ 0.05 and

the ratio (missed(hold) / all DTX from the SS) ≤ 0.1

NOTE: If the above Test Requirement differs from the Minimum Requirement then the Test Tolerance applied for this test is non-zero. The Test Tolerance for this test is defined in clause F.2 and the explanation of how the Minimum Requirement has been relaxed by the Test Tolerance is given in clause F.4.

10.3.1.1A Single link performance (10ms TTI, Type 1)

10.3.1.1A.1 Definition and applicability

The receive characteristics of the E-DCH Relative Grant Channel (E-RGCH) in multi-path fading environment is determined by the missed UP/DOWN. The requirements and this test apply to Release 7 and later releases for all types of UTRA for the FDD UE that support E-DCH and HSDPA and the optional Type 1 enhanced performance requirements.

Note: The fail cases for Up are Down (erroneous detection) and Hold (missed detection). The fail cases for Down are Up and Hold. TS 25.101 designated this test “Missed Up/Down”. It is assumed that the minimum requirements apply for both fail cases erroneous and missed detection.

10.3.1.1A.2 Minimum requirement

For the parameters specified in Table 10.3.1.1A.2.1 the average downlink E-RGCH E_c/I_{or} power ratio shall be below the specified value for the missed UP/DOWN probabilities in Table 10.3.1.1A.2.2.

Table 10.3.1.1A.2.1: Parameters for E-RGCH – Serving E-DCH cell

Parameter	Unit	Missed UP/DOWN
I_{oc}	dBm/3.84 MHz	-60
Phase reference	-	P-CPICH
P-CPICH E_c/I_{or}	dB	-10
E-RGCH signalling pattern	-	50% UP 50% DOWN

Table 10.3.1.1A.2.2: Enhanced performance requirement for Missed UP/DOWN when relative scheduling grant is transmitted using 12 consecutive slots – Serving E-DCH cell

Test Number	Propagation Conditions	Reference value		
		E-RGCH E_c/I_{or} (dB)	\hat{I}_{or} / I_{oc} (dB)	Missed UP/DOWN probability
1	VA30	-35	0	0.05/0.05

The reference for this requirement is TS 25.101 [1] clause 10.3.1

10.3.1.1A.3 Test purpose

To verify that average probability for missed up down, when E-RGCH is transmitted using 12 consecutive slots, do not exceed specified values.

10.3.1.1A.4 Method of test

10.3.1.1A.4.1 Initial conditions

Test environment: normal; see clauses G.2.1 and G.2.2.

Frequencies to be tested: mid range; see clause G.2.4.

- 1) Connect the SS and AWGN noise source and fading simulator to the UE antenna connector as shown in figure Figure A.21 for UEs that support receive diversity or figure A.10 for UEs that do not support receive diversity.
- 2) The UL Reference Measurement Channel parameters are defined in Annex C.11
- 3) Set the test parameters for the missed up down test as specified in table 10.3.1.1A.5.1. and 10.3.1.1A.5.2 and table E.5A.2. Set the fading conditions to VA 30
- 4) The value of Absolute Grant Scope shall be set to the 0. and the Absolute Grant shall be set to 5
- 5) The UE is switched on.
- 6) Enter the UE into loopback mode 1, looping back both the 12.2kbps RMC and HSDPA to E-DCH, and start the loopback test. See TS 34.108 [3] clause 7.3.9 and TS 34.109 [4] clauses 5.3.2.3 and 5.3.2.6. To fill the RLC transmit buffer, run the loopback for [3]s before starting the procedure.
- 7) The fading simulators are switched on.

10.3.1.1A.4.2 Procedure

Note: The measurement principle for the missed up down test (step 3 to 10) is as follows. The UE transmits E-DPCCH and E-DPDCH. The SS transmits E-RGCH up or down. The UE changes or holds the transport format of the corresponding E-DPCCH and E-DPDCH accordingly. This is visible for the SS by reading the E-TFCI, signalled on the corresponding E-DPCCH.

- 1) The Nominal Avg. Information Bit Rate in the DL is set to 534 kbps according to QPSK H-Set 1. The expected throughput under this level and fading conditions is 142 kbps. The expected UL datarate is 71.6 kbps corresponding to E-TFC Index 45.
- 2) Upon reception of every E-DPCCH and E-DPDCH, the SS signals always “DTX” on the E-HICH during the entire test. This way there is no E_HICH power. Nevertheless the UE will transmit new data, since “E-DCH MAC-d flow maximum number of retransmissions” is set to 0.
- 3) The SS signals 4 consecutive “down” on the E-RGCH
- 4) The SS reads the E-TFCI for 4 consecutive HARQ processes, signalled on the E-DPCCH, corresponding to these “down”
- 5) If the UE increases or holds the transport format at each HARQ process upon a “down” command, count a missed(down).

If the UE signals Happy Bit = 1, the UE may transmit less data than granted. (TS25.321 [13] section 11.8.1.5. bullet point 1) The corresponding E-DPCCH and E-DPDCH TTI is not counted as sample.

- 6) The SS signals 4 consecutive “up” on the E-RGCH
- 7) The SS reads the E-TFCI for 4 consecutive HARQ processes, signalled on the E-DPCCH corresponding to these “up”.
- 8) If the UE decreases or holds the transport format at each HARQ process upon an “up” command, count a missed(up).

If the UE signals Happy Bit = 1, the UE may transmit less data than granted. (TS25.321 [13] section 11.8.1.5. bullet point 1) The corresponding E-DPCCH and E-DPDCH TTI is not counted as sample.

- 9) Repeat the “down-up” cycle in step 3 to 8, such that statistical significance according to Annex F.6.4 is achieved for up and down separately.

Due to missed up or missed down the operating range will shift down or up. If the operating range shifts outside the range shown in Table 10.3.1.1A.4.2.1 the operating range must be re-adjusted.

Table 10.3.1.1A.4.2.1 E-TFCI operating point/range(10 ms)

missed up down	AG Value	β_{ed}/β_c	E-TFCI	TB Size=N*112 + Header + Padding	UL rate kbps
Initial operating range	6	24/15	59	1264 = 11*112 + 18 + 14	126.4
		21/15	52	951 = 8*112 + 18 + 37	95.1
	5	19/15	45	716 = 6*112 + 18 + 26	71.6
		17/15	40	584 = 5*112 + 18 + 6	58.4
	4	15/15	35	477 = 4*112 + 18 + 11	47.7
		13/15	28	359 = 3*112 + 18 + 4	35.9
		12/15	19	249 = 2*112 + 18 + 7	24.9

10) If one counter reaches the pass criterion, this counter is stopped and the remaining counter is continued. The missed up down test is decided pass, if the last counter reaches pass. The missed up down test is decided fail, if the first counter reaches fail.

Specific Message Contents

All messages indicated above shall use the same content as described in the default message content in clause 9.2.1 of 34.108 [3] with the following exceptions:

RADIO BEARER SETUP:

Information Element	Value/remark	Version
RLC PDU size	112	Rel-6
- E-DCH Transmission Time	10 ms	
E-DCH MAC-d flow maximum number of retransmissions	0	
E-DCH info		Rel-6
- Happy bit delay condition	10 ms (indication of exhausted resources on frame basis)	
- E-DCH minimum set E-TFCI	Not Present in RGCH performance tests, all E-TFCs should be in the selection process)	
Downlink information for each radio link list		
- Downlink information for each radio link		
- CHOICE E-RGCH Information		Rel-6
- E-RGCH Information		
- Signature Sequence	0	
- RG combination index	0	

10.3.1.1A.5 Test requirements

Table 10.3.1.1A.5.1: Test Parameters for E-RGCH – Serving E-DCH cell

Parameter	Unit	Missed UP/DOWN
I_{oc}	dBm/3.84 MHz	-60
Phase reference	-	P-CPICH
E-RGCH E_c/I_{or}	dB	-34.9 (test 1)
E-RGCH signalling pattern	-	50% UP 50% DOWN

Table 10.3.1.1A.5.2: Test requirement Type 1 for Missed UP/DOWN when relative scheduling grant is transmitted using 12 consecutive slots – Serving E-DCH cell

Test Number	Propagation Conditions	Reference value		
		E-RGCH E_c/I_{or} (dB)	\hat{I}_{or}/I_{oc} (dB)	Missed UP/DOWN probability
1	VA30	-34.9	0.6	0.05/0.05

To pass the test,

the ratio (missed(down) / all valid down commands, sent) ≤ 0.05 and

the ratio (missed(up) / all valid up commands, sent) ≤ 0.05

NOTE: If the above Test Requirement differs from the Minimum Requirement then the Test Tolerance applied for this test is non-zero. The Test Tolerance for this test is defined in clause F.2 and the explanation of how the Minimum Requirement has been relaxed by the Test Tolerance is given in clause F.4.

10.3.1.2 Single link performance (2ms TTI)

10.3.1.2.1 Definition and applicability

The receive characteristics of the E-DCH Relative Grant Channel (E-RGCH) in multi-path fading environment is determined by the missed UP/DOWN and missed HOLD. The requirements and this test apply to Release 6 and later releases for all types of UTRA for the FDD UE that support E-DCH with 2ms TTI and HSDPA.

Note: The fail cases for Up are Down (erroneous detection) and Hold (missed detection).

The fail cases for Down are Up and Hold. TS 25.101 designated this test “Missed Up/Down”. It is assumed that the minimum requirements apply for both fail cases erroneous and missed detection.

10.3.1.2.2 Minimum requirement

For the parameters specified in Table 10.3.1.2.2.1 the average downlink E-RGCH E_c/I_{or} power ratio shall be below the specified value for the missed UP/DOWN probabilities in Table 10.3.1.2. 2.2 and

For the parameters specified in Table 10.3.1.2.2.1 the missed HOLD probability shall be below the specified value in Table 10.3.1.2.2.3

Table 10.3.1.2.2.1: Parameters for E-RGCH – Serving E-DCH cell

Parameter	Unit	Missed UP/DOWN	Missed HOLD
I_{oc}	dBm/3.84 MHz	-60	
Phase reference	-	P-CPICH	
P-CPICH E_c/I_{or}	dB	-10	
E-RGCH signalling pattern	-	50% UP 50% DOWN	100% HOLD

Table 10.3.1.2.2.2: Minimum requirement for Missed UP/DOWN when relative scheduling grant is transmitted using 3 consecutive slots – Serving E-DCH cell

Test Number	Propagation Conditions	Reference value		
		E-RGCH E_c/I_{or} (dB)	\hat{I}_{or}/I_{oc} (dB)	Missed UP/DOWN probability
1	VA30	-24.4	0	0.05/0.05

Table 10.3.1.2.2.3: Minimum requirement for Missed HOLD when relative scheduling grant is transmitted using 3 consecutive slots – Serving E-DCH cell

Test Number	Propagation Conditions	Reference value	
		\hat{I}_{or} / I_{oc} (dB)	Missed HOLD probability
2	VA30	0	0.1

The reference for this requirement is TS 25.101 [1] clause 10.3.1

10.3.1.2.3 Test purpose

To verify that average probability for missed up down and average probability for missed hold when E-RGCH is transmitted using 12 consecutive slots do not exceed specified values.

10.3.1.2.4 Method of test

10.3.1.2.4.1 Initial conditions

Test environment: normal; see clauses G.2.1 and G.2.2.

Frequencies to be tested: mid range; see clause G.2.4.

- 1) Connect the SS and AWGN noise source and fading simulator to the UE antenna connector as shown in figure Figure A.10.
- 2) The UL Reference Measurement Channel parameters are defined in Annex C.11
- 3) Set the test parameters for the missed up down test and the missed hold test as specified in table 10.3.1.2.5.1 to 10.3.1.2.5.3 and table E.5A.2. Set the fading conditions to VA 30
- 4) The value of Absolute Grant Scope shall be set to the 0, and the Absolute Grant shall be set to 4
- 5) The UE is switched on.
- 6) Enter the UE into loopback mode 1, looping back both the 12.2kbps RMC and HSDPA to E-DCH, and start the loopback test. See TS 34.108 [3] clause 7.3.9 and TS 34.109 [4] clauses 5.3.2.3 and 5.3.2.6 To fill the RLC transmit buffer, run the loopback for [3]s before starting the procedure.
- 7) The fading simulator is switched on.

10.3.1.2.4.2 Procedure

Note: The measurement principle for the missed up down test (step 3 to 10) and for the missed hold test (step 11 to 15) is as follows. The UE transmits E-DPCCH and E-DPDCH. The SS transmits E-RGCH up or down or hold (DTX). The UE changes or holds the transport format of the corresponding E-DPCCH and E-DPDCH accordingly. This is visible for the SS by reading the E-TFCI, signalled on the corresponding E-DPCCH.

- 1) The Nominal Avg. Information Bit Rate in the DL is set to 534 kbps according to QPSK H-Set 1. The expected throughput under this level and fading conditions is 142 kbps. The UL data rate was configured by signalling AG value 4 on the E-AGCH. The expected UL datarate is 273 kbps corresponding to E-TFC Index 39.
- 2) Upon reception of every E-DPCCH and E-DPDCH, the SS signals always “DTX” on the E-HICH during the entire test. This way there is no E_HICH power. Nevertheless the UE will transmit new data, since “E-DCH MAC-d flow maximum number of retransmissions” is set to 0.
- 3) The SS signals 8 consecutive “up” on the E-RGCH
- 4) The SS reads the E-TFCI for 8 consecutive HARQ processes, signalled on the E-DPCCH, corresponding to these “up”
- 5) If the UE decreases or holds the transport format at each HARQ process upon a “up” command, count a missed(up).

RADIO BEARER SETUP:

Information Element	Value/remark	Version
- RLC PDU size	112	Rel-6
- E-DCH Transmission Time	10 ms (Test 2 and 4), 2ms (Test 1 and 3)	
E-DCH MAC-d flow maximum number of retransmissions	0	
E-DCH info		Rel-6
- Happy bit delay condition	10 ms (Test 2 and 4), 2ms (Test 1 and 3) (indication of exhausted resources on frame basis)	
- E-DCH minimum set E-TFCI	Not Present in RGCH performance tests, all E-TFCs should be in the selection process)	
Downlink information for each radio link list		
- Downlink information for each radio link		
- CHOICE E-RGCH Information		Rel-6
- E-RGCH Information		
- Signature Sequence	0	
- RG combination index	0	

10.3.1.2.5 Test requirements

Table 10.3.1.2.5.1: Test Parameters for E-RGCH – Serving E-DCH cell

Parameter	Unit	Missed UP/DOWN	Missed HOLD
I_{oc}	dBm/3.84 MHz	-60	
Phase reference	-	P-CPICH	
E-RGCH E_c/I_{or}	dB	-24.3 (test 1)	$-\infty$ (test 2)
E-RGCH signalling pattern	-	50% UP 50% DOWN	100% HOLD

Table 10.3.1.2.5.2: Test requirement for Missed UP/DOWN when relative scheduling grant is transmitted using 3 consecutive slots – Serving E-DCH cell

Test Number	Propagation Conditions	Reference value		
		E-RGCH E_c/I_{or} (dB)	\hat{I}_{or}/I_{oc} (dB)	Missed UP/DOWN probability
1	VA30	-24.3	0.6	0.05/0.05

Table 10.3.1.2.5.3: Test requirement for Missed HOLD when relative scheduling grant is transmitted using 3 consecutive slots – Serving E-DCH cell

Test Number	Propagation Conditions	Reference value	
		\hat{I}_{or}/I_{oc} (dB)	Missed HOLD probability
2	VA30	0.6	0.1

To pass the test,

the ratio (missed(down) / all valid down commands, sent) ≤ 0.05 and

the ratio (missed(up) / all valid up commands, sent) ≤ 0.05 and

the ratio (missed(hold) / all DTX from the SS) ≤ 0.1

NOTE : If the above Test Requirement differs from the Minimum Requirement then the Test Tolerance applied for this test is non-zero. The Test Tolerance for this test is defined in clause F.2 and the explanation of how the Minimum Requirement has been relaxed by the Test Tolerance is given in clause F.4.

10.3.1.2A Single link performance (2ms TTI, Type 1)

10.3.1.2A.1 Definition and applicability

The receive characteristics of the E-DCH Relative Grant Channel (E-RGCH) in multi-path fading environment is determined by the missed UP/DOWN. The requirements and this test apply to Release 7 and later releases for all types of UTRA for the FDD UE that support E-DCH with 2ms TTI and HSDPA and the optional Type 1 enhanced performance requirements.

Note: The fail cases for Up are Down (erroneous detection) and Hold (missed detection).

The fail cases for Down are Up and Hold. TS 25.101 designated this test “Missed Up/Down”. It is assumed that the minimum requirements apply for both fail cases erroneous and missed detection.

10.3.1.2A.2 Minimum requirement

For the parameters specified in Table 10.3.1.2A.2.1 the average downlink E-RGCH E_c/I_{or} power ratio shall be below the specified value for the missed UP/DOWN probabilities in Table 10.3.1.2A.2.2.

Table 10.3.1.2A.2.1: Parameters for E-RGCH – Serving E-DCH cell

Parameter	Unit	Missed UP/DOWN
I_{oc}	dBm/3.84 MHz	-60
Phase reference	-	P-CPICH
P-CPICH E_c/I_{or}	dB	-10
E-RGCH signalling pattern	-	50% UP 50% DOWN

Table 10.3.1.2A.2.2: Enhanced performance requirement for Missed UP/DOWN when relative scheduling grant is transmitted using 3 consecutive slots – Serving E-DCH cell

Test Number	Propagation Conditions	Reference value		
		E-RGCH E_c/I_{or} (dB)	\hat{I}_{or}/I_{oc} (dB)	Missed UP/DOWN probability
1	VA30	-28.6	0	0.05/0.05

The reference for this requirement is TS 25.101 [1] clause 10.3.1

10.3.1.2A.3 Test purpose

To verify that average probability for missed up down, when E-RGCH is transmitted using 12 consecutive slots, do not exceed specified values.

10.3.1.2A.4 Method of test

10.3.1.2A.4.1 Initial conditions

Test environment: normal; see clauses G.2.1 and G.2.2.

Frequencies to be tested: mid range; see clause G.2.4.

- 1) Connect the SS and AWGN noise source and fading simulator to the UE antenna connector as shown in figure Figure A.21 for UEs that support receive diversity or figure A.10 for UEs that do not support receive diversity.
- 2) The UL Reference Measurement Channel parameters are defined in Annex C.11
- 3) Set the test parameters for the missed up down test as specified in table 10.3.1.2A.5.1 and 10.3.1.2A.5.2 and table E.5A.2. Set the fading conditions to VA 30
- 4) The value of Absolute Grant Scope shall be set to the 0, and the Absolute Grant shall be set to 4
- 5) The UE is switched on.

6) Enter the UE into loopback mode 1, looping back both the 12.2kbps RMC and HSDPA to E-DCH, and start the loopback test. See TS 34.108 [3] clause 7.3.9 and TS 34.109 [4] clauses 5.3.2.3 and 5.3.2.6 To fill the RLC transmit buffer, run the loopback for [3]s before starting the procedure.

7) The fading simulators are switched on.

10.3.1.2A.4.2 Procedure

Note: The measurement principle for the missed up down test (step 3 to 10) is as follows. The UE transmits E-DPCCH and E-DPDCH. The SS transmits E-RGCH up or down. The UE changes or holds the transport format of the corresponding E-DPCCH and E-DPDCH accordingly. This is visible for the SS by reading the E-TFCI, signalled on the corresponding E-DPCCH.

1) The Nominal Avg. Information Bit Rate in the DL is set to 534 kbps according to QPSK H-Set 1. The expected throughput under this level and fading conditions is 142 kbps. The UL data rate was configured by signalling AG value 4 on the E-AGCH. The expected UL datarate is 273 kbps corresponding to E-TFC Index 39.

2) Upon reception of every E-DPCCH and E-DPDCH, the SS signals always “DTX” on the E-HICH during the entire test. This way there is no E_HICH power. Nevertheless the UE will transmit new data, since “E-DCH MAC-d flow maximum number of retransmissions” is set to 0.

3) The SS signals 8 consecutive “up” on the E-RGCH

4) The SS reads the E-TFCI for 8 consecutive HARQ processes, signalled on the E-DPCCH, corresponding to that “up”

5) If the UE decreases or holds the transport format at each HARQ process upon a “up” command, count a missed(up).

If the UE signals Happy Bit = 1, the UE may transmit less data than granted. (TS25.321 [13] section 11.8.1.5. bullet point 1) The corresponding E-DPCCH and E-DPDCH TTI is not counted as sample.

6) The SS signals 8 consecutive “down” on the E-RGCH

7) The SS reads the E-TFCI for 8 consecutive HARQ processes, signalled on the E-DPCCH corresponding to these “down”.

8) If the UE increases or holds the transport format upon a “down” command, count a missed(down).

If the UE signals Happy Bit = 1, the UE may transmit less data than granted. (TS25.321 [13] section 11.8.1.5. bullet point 1) The corresponding E-DPCCH and E-DPDCH TTI is not counted as sample.

9) Repeat the “up-down” cycle in step 3 to 8, such that statistical significance according to Annex F.6.4 is achieved for up and down separately.

10) If one counter reaches the pass criterion, this counter is stopped and the remaining counter is continued. The missed up down test is decided pass, if the last counter reaches pass. The missed up down test is decided fail, if the first counter reaches fail.

Due to missed up or missed down the operating range will shift down or up. If the operating point shifts into the range “risk of buffer underflow” or “ambiguous E-TFCI” (see Table 10.3.1.2A.4.2.1) the operating point must be re-adjusted.

Table 10.3.1.2A.4.2.1 E-TFCI operating point/range(2 ms)

missed up down	AG Value	β_{ed}/β_c	E-TFCI	TB Size=N*112+Header+min Padding	UL rate kbps
				Risk of buffer underflow	
		21/15	54	817 = 7*112 + 18 + 15	408
	5	19/15	50	707 = 6*112 + 18 + 17	353.5
Initial operating range		17/15	45	590 = 5*112 + 18 + 12	295.5
	4	15/15	39	474 = 4*112 + 18 + 8	273
		13/15	31	355 = 3*112 + 18 + 1	177.5
Ambiguous E-TFCI		12/15	21	247 = 2*112 + 18 + 5	123.5
	3	11/15	21	247 = 2*112 + 18 + 5	123.5

Specific Message Contents

All messages indicated above shall use the same content as described in the default message content in clause 9.2.1 of 34.108 [3] with the following exceptions:

RADIO BEARER SETUP:

Information Element	Value/remark	Version
- RLC PDU size	112	Rel-6
- E-DCH Transmission Time	10 ms (Test 2 and 4), 2ms (Test 1 and 3)	
E-DCH MAC-d flow maximum number of retransmissions	0	
E-DCH info		Rel-6
- Happy bit delay condition	10 ms (Test 2 and 4), 2ms (Test 1 and 3) (indication of exhausted resources on frame basis)	
- E-DCH minimum set E-TFCI	Not Present in RGCH performance tests, all E-TFCs should be in the selection process)	
Downlink information for each radio link list		
- Downlink information for each radio link		
- CHOICE E-RGCH Information		Rel-6
- E-RGCH Information		
- Signature Sequence	0	
- RG combination index	0	

10.3.1.2A.5 Test requirements

Table 10.3.1.2A.5.1: Test Parameters for E-RGCH – Serving E-DCH cell

Parameter	Unit	Missed UP/DOWN
I_{oc}	dBm/3.84 MHz	-60
Phase reference	-	P-CPICH
E-RGCH E_c/I_{or}	dB	-28.4 (test 1)
E-RGCH signalling pattern	-	50% UP 50% DOWN

Table 10.3.1.2A.5.2: Test requirement Type 1 for Missed UP/DOWN when relative scheduling grant is transmitted using 3 consecutive slots – Serving E-DCH cell

Test Number	Propagation Conditions	Reference value		
		E-RGCH E_c/I_{or} (dB)	\hat{I}_{or}/I_{oc} (dB)	Missed UP/DOWN probability
1	VA30	-28.4	0.6	0.05/0.05

To pass the test,

the ratio (missed(down) / all valid down commands, sent) ≤ 0.05 and

the ratio (missed(up) / all valid up commands, sent) ≤ 0.05

NOTE: If the above Test Requirement differs from the Minimum Requirement then the Test Tolerance applied for this test is non-zero. The Test Tolerance for this test is defined in clause F.2 and the explanation of how the Minimum Requirement has been relaxed by the Test Tolerance is given in clause F.4.

10.3.2 Detection in Inter-Cell Handover conditions

10.3.2.1 Definition and applicability

The receive characteristics of the E-DCH Relative Grant Channel (E-RGCH) is determined during an inter-cell soft handover by the missed UP/DOWN and missed HOLD error probabilities. During the soft handover a UE receives

signals from different cells. A UE has to be able to detect E-RGCH signalling from different cells, Serving E-DCH cell and Non-serving E-DCH RL.

The requirements and this test apply to Release 6 and later releases for all types of UTRA for the FDD UE that support E-DCH and HSDPA.

10.3.2.2 Minimum requirement for Non-serving E-DCH RL

For the parameters specified in Table 10.3.2.2.1 the missed HOLD probability shall be below the specified value in Table 10.3.2.2.2. For the parameters specified in Table 10.3.2.2.1 the average downlink E-RGCH E_c/I_{or} power ratio shall be below the specified value for the missed DOWN probabilities in Table 10.3.2.2.3.

Table 10.3.2.2.1: Requirement scenario parameters for E-RGCH – Non-serving E-DCH RL

Parameter	Unit	Missed HOLD	Missed DOWN
I_{oc}	dBm/3.84 MHz	-60	
Phase reference	-	P-CPICH	
P-CPICH E_c/I_{or}	dB	-10	
E-RGCH signalling pattern for Serving E-DCH cell	-	100% UP ¹	100% UP ¹
E-AGCH information	-	Fixed SG ²	Fixed SG ²
E-RGCH signalling pattern for Non-serving E-DCH RL	-	100% HOLD	100% DOWN
Note 1	Serving E-DCH cell E-RGCH E_c/I_{or} power level is set to -22 dB and relative scheduling grant is transmitted using 12 consecutive slots.		
Note 2	Serving E-DCH cell E-AGCH E_c/I_{or} power level is set to -15 dB and E-AGCH TTI length is 10ms.		

Table 10.3.2.2.2: Minimum requirement for Missed HOLD when relative scheduling grant is transmitted using 15 consecutive slots – Non-serving E-DCH RL

Test Number	Propagation Conditions	Reference value	
		\hat{I}_{or1}/I_{oc} and \hat{I}_{or2}/I_{oc} (dB)	Missed HOLD probability
1	VA30	0	0.005

Table 10.3.2.2.3: Minimum requirement for Missed DOWN when relative scheduling grant is transmitted using 15 consecutive slots – Non-serving E-DCH RL

Test Number	Propagation Conditions	Reference value		
		E-RGCH E_c/I_{or} (dB)	\hat{I}_{or1}/I_{oc} and \hat{I}_{or2}/I_{oc} (dB)	Missed DOWN probability
2	VA30	-27.3	0	0.05

The reference for this requirement is TS 25.101 [1] clause 10.3.2.

10.3.2.3 Test Purpose

To verify that during an inter-cell soft handover the average probability for missed HOLD and the average probability for missed DOWN do not exceed specified values.

10.3.2.4 Method of test

10.3.2.4.1 Initial conditions

Test environment: normal; see clauses G.2.1 and G.2.2.

Frequencies to be tested: mid range; see clause G.2.4.

- 1) Connect the SS and AWGN noise source and fading simulators to the UE antenna connector as shown in figure Figure A.11.
- 2) The UL Reference Measurement Channel parameters are defined in Annex C.11.
- 3) Set the test parameters for the missed HOLD and missed DOWN test as specified in table 10.3.2.5.1 to 10.3.2.5.3 and table E.5A.3, with the exception of \hat{I}_{or2} that shall be set to $-\infty$. Set the fading conditions to VA 30.
- 4) The value of Absolute Grant Scope shall be set to 0, and the Absolute Grant shall be set to 5.
- 5) The UE is switched on.
- 6) Enter the UE into loopback mode 1, looping back both the 12.2kbps RMC and HSDPA to E-DCH, and start the loopback test. See TS 34.108 [3] clause 7.3.9 and TS 34.109 [4] clauses 5.3.2.3 and 5.3.2.6. To fill the RLC transmit buffer, run the loopback for [3]s before starting the procedure.
- 7) Reset \hat{I}_{or2} according to tables 10.3.2.5.2 to 10.3.2.5.3. The downlink DPCH of cell 2 must remain inactivated.
- 8) UE shall transmit a MEASUREMENT REPORT message triggered by event 1A containing the CFN-SFN time difference between cell 1 and cell 2.
- 9) The downlink DPCH of cell 2 shall be activated.
- 10) SS shall send an ACTIVE SET UPDATE message adding cell 2 to the active set.
- 11) The fading simulators are switched on.

10.3.2.4.2 Procedure

Note: The measurement principle of the missed hold test (step 3 to 5) is as follows: Upon the UE transmission on E-DPCCH and E-DPDCH, the SS responds as follows: Cell 1 responds “up” on the E-RGCH and a fixed SG on the E-AGCH. Cell 2 responds DTX=hold. The SS reads the transport format, signalled on the E-DPCCH, corresponding to that signalling. If the E-TFCI is not changed, the reception on cell 2 is interpreted as hold. If the E-TFCI is decreased by one step, the DTX on cell 2 was received as down. If the E-TFCI is increased to the fixed SG, then the hold on cell 2 was received correctly and the Non_Serving_RG_Timer has expired.

1. The Nominal Avg. Information Bit Rate in the DL is set to 534 kbps according to QPSK H-Set 1. The expected throughput under this level and fading conditions is tested with a single cell in clause 9.2.1, but the DL throughput for this test case will be less than for the single cell case because of interference from Cell 2. The DL throughput for this test case is estimated based on the HSDPA throughput corresponding to the subtests using “HS-PDSCH Ec/Ior = -6dB” condition in 9.2.1A. The worst case for a conformant UE is 22 kbps. The UL datarate was configured by signalling AG value = 5 on the E-AGCH. The expected UL datarate is 71.6 kbps corresponding to E-TFC Index 45.
2. Upon reception of every E-DPCCH and E-DPDCH, the SS signals always “DTX” on the E-HICH during the entire test. This way there is no E_HICH power. Nevertheless the UE will transmit new data, since “E-DCH MAC-d flow maximum number of retransmissions” is set to 0.
3. Upon reception of the E-DPCCH and E-DPDCH, the SS signals “up” on the E-RGCH and AG value = 5 on the E-AGCH of cell 1 and “DTX” on the E-RGCH of cell 2.
4. The SS reads the E-TFCI transport, signalled on the E-DPCCH, corresponding to that “up and SG”.
5. If the UE decreases the E-TFCI by one step, the DTX on the E-RGCH of cell 2 was received as “down”. Count a missed(hold). If the UE holds the E-TFCI, count a correct sample.

Figure 10.3.2.4.2.1 Void

Table 10.3.2.4.2.2 E-TFCI operating range (10 ms)

Missed hold applicability	Missed down applicability	AG Value	β_{ed}/β_c	E-TFCI	TB Size = N*112 + Header + Padding	UL rate kbps
		6	24/15	59	1264 = 11*112 + 18 + 14	126.4
			21/15	52	951 = 8*112 + 18 + 37	95.1
Fixed SG Applicable SG range	Fixed SG Applicable SG range	5	19/15	45	716 = 6*112 + 18 + 26	71.6
			17/15	40	584 = 5*112 + 18 + 6	58.4
		4	15/15	35	477 = 4*112 + 18 + 11	47.7
			13/15	28	359 = 3*112 + 18 + 4	35.9
			12/15	19	249 = 2*112 + 18 + 7	24.9

If the UE increases the E-TFCI by one or more steps at one instant to the fixed SG, signalled on the E-AGCH, the Non_Serving_RG_Timer has expired.

If the UE signals Happy Bit = 1, the UE may transmit less data than granted. (TS25.321 [13] section 11.8.1.5. bullet point 1) The corresponding E-DPCCH and E-DPDCH blocks are not counted as sample.

If the UE decreases the E-TFCI due to several missed hold to the TFCI = 19, (TFCI =45 → 40 → 35 → 28 → 19) without Non_Serving_RG_Timer expired, fail the UE.

6. Repeat step 3) to 5) such that statistical significance according to Annex F.6.4 is achieved.

Note: The measurement principle of the missed down test (step 8 to 10) is as follows: Upon the UE transmission on E-DPCCH and E-DPDCH, the SS responds as follows: Cell 1 sends “up” on the E-RGCH and a fixed SG on the E-AGCH. Cell 2 sends down. The SS reads the transport format, signalled on the E-DPCCH, corresponding to that signalling. If the transport format is decreased by one step, the Down on cell 2 was received correctly as down. If the transport format is not changed or is increased, the down on cell 2 was missed.

7. Repeat the settings of step 1

8. The SS signals 12 consecutive “down” on the E-RGCH of cell 2 followed by a sequence of hold. The SS signals up on the E-RGCH of cell 1 and AG value = 5 on the E-AGCH always. (To avoid the lower limit of SG after several down in sequence, the SS signals hold continuously on cell 2 until the initial transport format is re-established. The SS should not count the E-TFCI as samples during signalling hold.). The SS shall take into account that UE may falsely detect “Hold” of the non-serving cell to “Down”. The SS behaviour in such case is FFS.

9. The SS reads the E-TFCI at each HARQ process, signalled on the E-DPCCH corresponding to that “down on the E-RGCH of cell 2.

10. If the UE does not decrease the E-TFCI by one step at each HARQ process upon that “down on cell 2” record a missed(down). Otherwise count a correct sample.

If the UE signals Happy Bit = 1, the UE may transmit less data than granted. (TS25.321 [13] section 11.8.1.5. bullet point 1) The corresponding E-DPCCH and E-DPDCH blocks are not counted as sample.

Figure 10.3.2.4.2.3 Void

11. Repeat step 8 to 10, such that statistical significance according to Annex F.6.4 is achieved.

Specific Message Contents

All messages indicated above shall use the same content as described in the default message content in clause 9.2.1 of 34.108 [3] with the following exceptions:

RADIO BEARER SETUP

Information Element	Value/remark	Version
- RLC PDU size	112	Rel-6
- E-DCH Transmission Time	10 ms	
E-DCH MAC-d flow maximum number of retransmissions	0	
E-DCH info		Rel-6
- Happy bit delay condition	10 ms	
- E-DCH minimum set E-TFCI	Not Present in RGCH performance tests, all E-TFCs should be in the selection process)	
Downlink information for each radio link list		
- Downlink information for each radio link		
- CHOICE E-RGCH Information		Rel-6
- E-RGCH Information		
- Signature Sequence	0	
- RG combination index	0	

ACTIVE SET UPDATE message:

Information Element/Group name	Value/Remark	Version
Message Type (10.2.17)		
UE information elements - RRC transaction identifier - Integrity check info -message authentication code -RRC message sequence number - Activation time - New U-RNTI - New H-RNTI - New Primary E-RNTI - New Secondary E-RNTI	0 SS calculates the value of MAC-I for this message and writes to this IE. The first/ leftmost bit of the bit string contains the most significant bit of the MAC-I. SS provides the value of this IE, from its internal counter. "now". Not Present Not Present Not Present Not Present	 Rel-6 Rel-6 Rel-6
CN information elements - CN Information info	Not Present	
Phy CH information elements Uplink radio resources - Maximum allowed UL TX power	33 dBm	
Downlink radio resources - Radio link addition information - Radio link addition information - Primary CPICH info - Primary scrambling code - Downlink DPCH info for each RL	1 Same as adding cell	
- CHOICE mode - Primary CPICH usage for channel estimation - DPCH frame offset - Secondary CPICH info	FDD Primary CPICH may be used This should be reflected by the IE" Cell synchronisation information" in received MEASUREMENT REPORT message Not Present	
- DL channelisation code - Secondary scrambling code - Spreading factor - Code number - Scrambling code change - TPC combination index - Closed loop timing adjustment mode - Downlink F-DPCH info for each RL	Not Present 128 96 No code change 1 Not Present Not Present	
E-HICH Information - Channelisation Code - Signature Sequence	6 1	Rel-6
E-RGCH Information - Signature Sequence - RG combination index	0 1	Rel-6
- Radio link removal information - TX Diversity Mode	Not Present Not Present	
Serving HS-DSCH cell information	Not Present	Rel-6
E-DCH reconfiguration information	Not Present	Rel-6

10.3.2.5 Test Requirements

For table 10.3.2.5.1, the missed HOLD probability shall be below the specified value in Table 10.3.2.5.2. For table 10.3.2.5.1, the average downlink E-RGCH E_c/I_{or} power ratio shall be below the specified value for the missed DOWN probabilities in Table 10.3.2.5.3

Table 10.3.2.5.1: Test scenario parameters for E-RGCH – Non-serving E-DCH RL

Parameter	Unit	Missed HOLD	Missed DOWN
I_{oc}	dBm/3.84 MHz	-60	
Phase reference	-	P-CPICH	
E-RGCH ₁ E_c/I_{or}	dB	-21.9	
E-AGCH ₁ E_c/I_{or}	dB	-14.9	
E-RGCH ₂ E_c/I_{or}	dB	$-\infty$	-27.2
HS-DPSCH ₁ E_c/I_{or}	dB	-3.1	-3.1
E-RGCH signalling pattern for Serving E-DCH cell	-	100% UP ¹	100% UP ¹
E-AGCH information		Fixed SG ²	Fixed SG ²
E-RGCH signalling pattern for Non-serving E-DCH RL		100% HOLD	100% DOWN
Note 1	Index 1: cell belonging to RLS containing the Serving E-DCH cell, Index 2: cell belonging to RLS not containing the Serving E-DCH cell		
Note 2	Serving E-DCH cell E-RGCH E_c/I_{or} power level is set to -22 dB+TT and relative scheduling grant is transmitted using 12 consecutive slots.		
Note 3	Serving E-DCH cell E-AGCH E_c/I_{or} power level is set to -15+TT dB and E-AGCH TTI length is 10ms. TT is added to Serving E-DCH cell E-RGCH E_c/I_{or} and E-AGCH E_c/I_{or} power. E-RGCH and E-AGCH reception on the serving cell is outside the test purpose. However reception errors may cause incorrect interpretation of the wanted test.		

Table 10.3.2.5.2: Test requirements for Missed HOLD when relative scheduling grant is transmitted using 15 consecutive slots – Non-serving E-DCH RL

Test Number	Propagation Conditions	Reference value	
		\hat{I}_{or1}/I_{oc} and \hat{I}_{or2}/I_{oc} (dB)	Missed HOLD probability
1	VA30	0.6	0.005

Table 10.3.2.5.3: Test requirements for Missed DOWN when relative scheduling grant is transmitted using 15 consecutive slots – Non-serving E-DCH RL

Test Number	Propagation Conditions	Reference value		
		E-RGCH E_c/I_{or} (dB)	\hat{I}_{or1}/I_{oc} and \hat{I}_{or2}/I_{oc} (dB)	Missed DOWN probability
2	VA30	-27.2	0.6	0.05

To pass the test,

The ratio (missed (hold) / all DTX from the SS) ≤ 0.005 and

The ratio (missed (down) / all valid down commands, sent) ≤ 0.05

NOTE : If the above Test Requirement differs from the Minimum Requirement then the Test Tolerance applied for this test is non-zero. The Test Tolerance for this test is defined in clause F.2 and the explanation of how the Minimum Requirement has been relaxed by the Test Tolerance is given in clause F.4.

10.3.2A Detection in Inter-Cell Handover conditions (Type 1)

10.3.2A.1 Definition and applicability

The receive characteristics of the E-DCH Relative Grant Channel (E-RGCH) is determined during an inter-cell soft handover by the missed UP/DOWN error probabilities. During the soft handover a UE receives signals from different cells. A UE has to be able to detect E-RGCH signalling from different cells, Serving E-DCH cell and Non-serving E-DCH RL.

The requirements and this test apply to Release 7 and later releases for all types of UTRA for the FDD UE that support E-DCH and HSDPA and the optional Type 1 enhanced performance requirements.

10.3.2A.2 Minimum requirement for Non-serving E-DCH RL

For the parameters specified in Table 10.3.2A.2.1 the average downlink E-RGCH E_c/I_{or} power ratio shall be below the specified value for the missed DOWN probabilities in Table 10.3.2A.2.2.

Table 10.3.2A.2.1: Requirement scenario parameters for E-RGCH – Non-serving E-DCH RL

Parameter	Unit	Missed DOWN
I_{oc}	dBm/3.84 MHz	-60
Phase reference	-	P-CPICH
P-CPICH E_c/I_{or}	dB	-10
E-RGCH signalling pattern for Serving E-DCH cell	-	100% UP ¹
E-AGCH information		Fixed SG ²
E-RGCH signalling pattern for Non-serving E-DCH RL		100% DOWN
Note 1	Serving E-DCH cell E-RGCH E_c/I_{or} power level is set to -22 dB and relative scheduling grant is transmitted using 12 consecutive slots.	
Note 2	Serving E-DCH cell E-AGCH E_c/I_{or} power level is set to -15 dB and E-AGCH TTI length is 10ms.	

Table 10.3.2A.2.2: Enhanced performance requirement for Missed DOWN when relative scheduling grant is transmitted using 15 consecutive slots – Non-serving E-DCH RL

Test Number	Propagation Conditions	Reference value		
		E-RGCH E_c/I_{or} (dB)	\hat{I}_{or1}/I_{oc} and \hat{I}_{or2}/I_{oc} (dB)	Missed DOWN probability
2	VA30	-31.2	0	0.05

The reference for this requirement is TS 25.101 [1] clause 10.3.2.

10.3.2A.3 Test Purpose

To verify that during an inter-cell soft handover the average probability for missed DOWN do not exceed specified values.

10.3.2A.4 Method of test

10.3.2A.4.1 Initial conditions

Test environment: normal; see clauses G.2.1 and G.2.2.

Frequencies to be tested: mid range; see clause G.2.4.

- 1) Connect the SS and AWGN noise source and fading simulators to the UE antenna connector as shown in figure Figure A.24 for UEs that support receive diversity or figure A.11 for UEs that do not support receive diversity.
- 2) The UL Reference Measurement Channel parameters are defined in Annex C.11.
- 3) Set the test parameters for the missed DOWN test as specified in table 10.3.2A.5.1 and 10.3.2A.5.2 and table E.5A.3 with the exception of \hat{I}_{or2} that shall be set to $-\infty$. Set the fading conditions to VA 30.
- 4) The value of Absolute Grant Scope shall be set to the 0, and the Absolute Grant shall be set to 5.
- 5) The UE is switched on.

- 6) Enter the UE into loopback mode 1, looping back both the 12.2kbps RMC and HSDPA to E-DCH, and start the loopback test. See TS 34.108 [3] clause 7.3.9 and TS 34.109 [4] clauses 5.3.2.3 and 5.3.2.6. To fill the RLC transmit buffer, run the loopback for [3]s before starting the procedure.
- 7) Reset \hat{I}_{or2} according to tables 10.3.2A.5.1 to 10.3.2A.5.2. The downlink DPCH of cell 2 must remain inactivated.
- 8) UE shall transmit a MEASUREMENT REPORT message triggered by event 1A containing the CFN-SFN time difference between cell 1 and cell 2.
- 9) The downlink DPCH of cell 2 shall be activated.
- 10) SS shall send an ACTIVE SET UPDATE message adding cell 2 to the active set.
- 11) The fading simulators are switched on.

10.3.2A.4.2 Procedure

Note: The measurement principle of the missed down test is as follows: Upon the UE transmission on E-DPCCH and E-DPDCH, the SS responds as follows: Cell 1 sends “up” on the E-RGCH and a fixed SG on the E-AGCH. Cell 2 sends down. The SS reads the transport format, signalled on the E-DPCCH, corresponding to that signalling. If the transport format is decreased by one step, the Down on cell 2 was received correctly as down. If the transport format is not changed or is increased, the down on cell 2 was missed.

1. The Nominal Avg. Information Bit Rate in the DL is set to 534 kbps according to QPSK H-Set 1. The expected throughput under this level and fading conditions is tested with a single cell in clause 9.2.1, but the DL throughput for this test case will be less than for the single cell case because of interference from Cell 2. The DL throughput for this test case is estimated based on the HSDPA throughput corresponding to the subtests using “HS-PDSCH Ec/Ior = -6dB” condition in 9.2.1A. The worst case for a conformant UE is 22 kbps. The UL datarate was configured by signalling AG value = 5 on the E-AGCH. The expected UL datarate is 71.6 kbps corresponding to E-TFC Index 45.

Table 10.3.2A.4.2.1 E-TFCI operating range (10 ms)

Missed down applicability	AG Value	β_{ed}/β_c	E-TFCI	TB Size = N*112 + Header + Padding	UL rate kbps
	6	24/15	59	1264 = 11*112 + 18 + 14	126.4
		21/15	52	951 = 8*112 + 18 + 37	95.1
Fixed SG	5	19/15	45	716 = 6*112 + 18 + 26	71.6
Applicable SG range		17/15	40	584 = 5*112 + 18 + 6	58.4
	4	15/15	35	477 = 4*112 + 18 + 11	47.7
		13/15	28	359 = 3*112 + 18 + 4	35.9
		12/15	19	249 = 2*112 + 18 + 7	24.9

2. The SS signals 12 consecutive “down” on the E-RGCH of cell 2 followed by a sequence of hold. The SS signals up on the E-RGCH of cell 1 and AG value = 5 on the E-AGCH always. (To avoid the lower limit of SG after several down in sequence, the SS signals hold continuously on cell 2 until the initial transport format is re-established.). The SS should not count the E-TFCI as samples during signalling hold.). The SS shall take into account that UE may falsely detect “Hold” of the non-serving cell to “Down”. This is FFS.
3. The SS reads the E-TFCI at each HARQ process, signalled on the E-DPCCH corresponding to that “down on the E-RGCH of cell 2.
4. If the UE does not decrease the E-TFCI by one step at each HARQ process upon that “down on cell 2” record a missed(down). Otherwise count a correct sample.
- If the UE signals Happy Bit = 1, the UE may transmit less data than granted. (TS25.321 [13] section 11.8.1.5. bullet point 1) The corresponding E-DPCCH and E-DPDCH blocks are not counted as sample.
5. Repeat step 2 to 4, such that statistical significance according to Annex F.6.4 is achieved.

Specific Message Contents

All messages indicated above shall use the same content as described in the default message content in clause 9.2.1 of 34.108 [3] with the following exceptions:

RADIO BEARER SETUP

Information Element	Value/remark	Version
- RLC PDU size	112	Rel-6
- E-DCH Transmission Time	10 ms	
E-DCH MAC-d flow maximum number of retransmissions	0	
E-DCH info		Rel-6
- Happy bit delay condition	10 ms	
- E-DCH minimum set E-TFCI	Not Present in RGCH performance tests, all E-TFCs should be in the selection process)	
Downlink information for each radio link list		
- Downlink information for each radio link		
- CHOICE E-RGCH Information		Rel-6
- E-RGCH Information		
- Signature Sequence	0	
- RG combination index	0	

ACTIVE SET UPDATE message:

Information Element/Group name	Value/Remark	Version
Message Type (10.2.17)		
UE information elements - RRC transaction identifier - Integrity check info -message authentication code -RRC message sequence number - Activation time - New U-RNTI - New H-RNTI - New Primary E-RNTI - New Secondary E-RNTI	0 SS calculates the value of MAC-I for this message and writes to this IE. The first/ leftmost bit of the bit string contains the most significant bit of the MAC-I. SS provides the value of this IE, from its internal counter. "now". Not Present Not Present Not Present Not Present	 Rel-6 Rel-6 Rel-6
CN information elements - CN Information info	Not Present	
Phy CH information elements Uplink radio resources - Maximum allowed UL TX power	33 dBm	
Downlink radio resources - Radio link addition information - Radio link addition information - Primary CPICH info - Primary scrambling code - Downlink DPCH info for each RL	1 Same as adding cell	
- CHOICE mode - Primary CPICH usage for channel estimation - DPCH frame offset - Secondary CPICH info	FDD Primary CPICH may be used This should be reflected by the IE" Cell synchronisation information" in received MEASUREMENT REPORT message Not Present	
- DL channelisation code - Secondary scrambling code - Spreading factor - Code number - Scrambling code change - TPC combination index - Closed loop timing adjustment mode - Downlink F-DPCH info for each RL	Not Present 128 96 No code change 1 Not Present Not present	
E-HICH Information - Channelisation Code - Signature Sequence	6 1	Rel-6
E-RGCH Information - Signature Sequence - RG combination index	Not Present 0 1	Rel-6
- Radio link removal information - TX Diversity Mode	Not Present Not Present	
Serving HS-DSCH cell information	Not Present	Rel-6
E-DCH reconfiguration information	Not Present	Rel-6

10.3.2A.5 Test Requirements

For table 10.3.2A.5.1, the average downlink E-RGCH E_c/I_{or} power ratio shall be below the specified value for the missed DOWN probabilities in Table 10.3.2A.5.2

Table 10.3.2A.5.1: Test scenario parameters for E-RGCH – Non-serving E-DCH RL

Parameter	Unit	Missed DOWN
I_{oc}	dBm/3.84 MHz	-60
Phase reference	-	P-CPICH
E-RGCH ₁ E_c/I_{or}	dB	-21.9
E-AGCH ₁ E_c/I_{or}	dB	-14.9
E-RGCH ₂ E_c/I_{or}	dB	-31.1
HS-DPSCH ₁ E_c/I_{or}	dB	-3.1
E-RGCH signalling pattern for Serving E-DCH cell	-	100% UP ¹
E-AGCH information		Fixed SG ²
E-RGCH signalling pattern for Non-serving E-DCH RL		100% DOWN
Note 1	Index 1: cell belonging to RLS containing the Serving E-DCH cell, Index 2: cell belonging to RLS not containing the Serving E-DCH cell	
Note 2	Serving E-DCH cell E-RGCH E_c/I_{or} power level is set to -22 dB+TT and relative scheduling grant is transmitted using 12 consecutive slots.	
Note 3	Serving E-DCH cell E-AGCH E_c/I_{or} power level is set to -15+TT dB and E-AGCH TTI length is 10ms. TT is added to Serving E-DCH cell E-RGCH E_c/I_{or} and E-AGCH E_c/I_{or} power. E-RGCH and E-AGCH reception on the serving cell is outside the test purpose. However reception errors may cause incorrect interpretation of the wanted test.	

Table 10.3.2A.5.2: Test requirements Type 1 for Missed DOWN when relative scheduling grant is transmitted using 15 consecutive slots – Non-serving E-DCH RL

Test Number	Propagation Conditions	Reference value		
		E-RGCH E_c/I_{or} (dB)	\hat{I}_{or1}/I_{oc} and \hat{I}_{or2}/I_{oc} (dB)	Missed DOWN probability
2	VA30	-31.1	0.6	0.05

To pass the test,

The ratio (missed (down) / all valid down commands, sent) ≤ 0.05

NOTE : If the above Test Requirement differs from the Minimum Requirement then the Test Tolerance applied for this test is non-zero. The Test Tolerance for this test is defined in clause F.2 and the explanation of how the Minimum Requirement has been relaxed by the Test Tolerance is given in clause F.4.

10.4 Demodulation of E-DCH Absolute Grant Channel (E-AGCH)

10.4.1 Single link performance

10.4.1.1 Definition and applicability

The receive characteristics of the E-DCH Absolute Grant Channel (E-AGCH) in multi-path fading environment is determined by the missed detection probability. The requirements and this test apply to Release 6 and later releases for all types of UTRA for the FDD UE that support HSDPA and E-DCH.

10.4.1.2 Minimum requirement

For the parameters specified in Table 10.4.1.1 the average downlink E-AGCH E_c/I_{or} power ratio shall be below the specified value for the missed detection probability in Table 10.4.1.2.

Table 10.4.1.1: Test parameters for E-AGCH detection – single link

Parameter	Unit	Missed detection
I_{oc}	dBm/3.84 MHz	-60
Phase reference	-	P-CPICH
P-CPICH E_c/I_{or}	dB	-10
E-AGCH information	-	Varying SG
E-AGCH TTI length	ms	10

Table 10.4.1.2: Minimum requirement for E-AGCH detection – single link

Test Number	Propagation Conditions	Reference value		
		E-AGCH E_c/I_{or} (dB)	\hat{I}_{or}/I_{oc} (dB)	Miss detection probability
1	VA30	-23.2	0	0.01

10.4.1.3 Test Purpose

The aim of the test is to verify that the missed detection probability of the E-AGCH channel does not exceed 0.01.

10.4.1.4 Method of test

10.4.1.4.1 Initial conditions

Test environment: normal; see clause G.2.1 and G.2.2.

Frequencies to be tested: mid range; see clause G.2.4

- 1) Connect the SS and AWGN noise source and fading simulator to the UE antenna connector as shown in Figure A.10.
- 2) The UL Reference Measurement Channel parameters are defined in Annex C.11.
- 3) Set the test parameters for the missed detection test as specified in Table 10.4.1.3, 10.4.1.3a and Table E.5A.2. Setup the fading simulator as per the fading condition, which is described in Table 10.4.1.3a.
- 4) Relative Grant shall not be transmitted on the E-RGCH and only Absolute Grant sent on E-AGCH will affect the Serving Grant (SG).
- 5) The value of Absolute Grant Scope shall be set to the 0 and the Absolute Grant shall be set to the 4.
- 6) The UE is switched on.
- 7) Enter the UE into loopback mode 1 looping back both the 12.2kbps RMC and HSDPA to E-DCH and start the loopback test. See TS34.108[3] clause 7.3.9 and TS34.109[4] clause 5.3.2.3 and 5.3.2.6 for details regarding loopback test mode for HSDPA and E-DCH. This way the UE is configured to transmit a data stream on the E-DPDCH with E-DPCCH. To fill the RLC transmit buffer, run the loopback for [3]s before starting the procedure.
- 8) Switch on the fading simulator

10.4.1.4.2 Procedure

- 1) The SS shall signal 100% ACK on the E-HICH for all processes.
- 2) The SS shall signal the Absolute Grants according to the E-AGCH information sequence as defined in Table 10.4.1.3.
- 3) The SS shall analyse the E-TFCI transmitted on the E-DPCCH for each E-DCH TTI to determine if a missed detection event has occurred by correlating the detected E-TFCIs with the expected E-TFCIs corresponding to the absolute grant sequence sent on E-AGCH. If the expected E-TFC is not detected by the SS, record a missed detection event.
- 4) The test shall be run such that statistical significance according to Annex F.6.4 is achieved.

Specific Message Contents

All messages indicated above shall use the same content as described in the default message content in clause 9.2.1 of 34.108 [3] with the following exceptions:

RADIO BEARER SETUP:

Information Element	Value/remark
E-DCH MAC-d flow maximum number of retransmissions	0

10.4.1.5 Test Requirements

The missed detection probability shall not exceed to the values specified in Table 10.4.1.3a.

The missed detection probability = the ratio of (missed detection event)/ (all detected E-TFCI event) ≤ 0.01 .

Tables 10.4.1.3 and 10.4.1.3a define the primary level settings including test tolerance and test parameters for the test.

Table 10.4.1.3: Test parameters for E-AGCH detection – single link

Parameter	Unit	Missed detection
I_{oc}	dBm/3.84 MHz	-60
Phase reference	-	P-CPICH
P-CPICH E_c/I_{or}	dB	-10
E-AGCH information		The E-AGCH information sequence “AG ₄ AG ₈ AG ₁₀ AG ₄ AG ₈ AG ₁₀ AG ₄ AG ₈ AG ₁₀ ...” shall be transmitted continuously, where AG ₄ , AG ₈ and AG ₁₀ denote absolute grant index of 4, 8, 10 respectively
E-AGCH TTI length	ms	10
E-HICH E_c/I_{or}	dB	-20
β_c		15/15
β_d		5/15
β_{hs}		15/15

Table 10.4.1.3a: Test requirement for E-AGCH detection – single link

Test Number	Propagation Conditions	Reference value		
		E-AGCH E_c/I_{or} (dB)	\hat{I}_{or}/I_{oc} (dB)	Miss detection probability
1	VA30	-23.1	0.6	0.01

The exact mapping of the E-AGCH absolute grant indices and the expected E-TFCIs is shown in Table 10.4.1.4. The mapping shall be used by the SS to compute the missed detection probability.

Table 10.4.1.4: Mapping of the E-AGCH test sequence and the expected E-TFCI

Absolute Grant Index	Expected E-TFCI index
AG ₄	E-TFCI ₂₈
AG ₈	E-TFCI ₆₇
AG ₁₀	E-TFCI ₈₁
Note:	E-TFCI ₂₈ , E-TFCI ₆₇ , E-TFCI ₈₁ denotes the E-TFCI index of 28, 67 and 81 from 10ms TTI Table 0 in 25.321[13]. This mapping is based on the assumption that 1, 5 or 9 RLC PDUs of size 336 bits are used respectively.

10.4.1A Single link performance (Type 1)

10.4.1A.1 Definition and applicability

The receive characteristics of the E-DCH Absolute Grant Channel (E-AGCH) in multi-path fading environment is determined by the missed detection probability. The requirements and this test apply to Release 7 and later releases for all types of UTRA for the FDD UE that support HSDPA and E-DCH and the optional Type 1 enhanced performance requirements.

10.4.1A.2 Minimum requirement

For the parameters specified in Table 10.4.1A.1 the average downlink E-AGCH E_c/I_{or} power ratio shall be below the specified value for the missed detection probability in Table 10.4.1A.2.

Table 10.4.1A.1: Test parameters for E-AGCH detection – single link

Parameter	Unit	Missed detection
I_{oc}	dBm/3.84 MHz	-60
Phase reference	-	P-CPICH
P-CPICH E_c/I_{or}	dB	-10
E-AGCH information	-	Varying SG
E-AGCH TTI length	ms	10

Table 10.4.1A.2: Enhanced performance requirement for E-AGCH detection – single link

Test Number	Propagation Conditions	Reference value		
		E-AGCH E_c/I_{or} (dB)	\hat{I}_{or}/I_{oc} (dB)	Miss detection probability
1	VA30	-26.8	0	0.01

10.4.1A.3 Test Purpose

The aim of the test is to verify that the missed detection probability of the E-AGCH channel does not exceed 0.01.

10.4.1A.4 Method of test

10.4.1A.4.1 Initial conditions

Test environment: normal; see clause G.2.1 and G.2.2.

Frequencies to be tested: mid range; see clause G.2.4

- 1) Connect the SS and AWGN noise source and fading simulator to the UE antenna connector as shown in Figure A.21 for UEs that support receive diversity or figure A.10 for UEs that do not support receive diversity.
- 2) The UL Reference Measurement Channel parameters are defined in Annex C.11.
- 3) Set the test parameters for the missed detection test as specified in Table 10.4.1.3 and 10.4.1A.5 and Table E.5A.2. Setup the fading simulator as per the fading condition, which is described in Table 10.4.1A.2.
- 4) Relative Grant shall not be transmitted on the E-RGCH and only Absolute Grant sent on E-AGCH will affect the Serving Grant (SG).
- 5) The value of Absolute Grant Scope shall be set to the 0 and the Absolute Grant shall be set to the 4.
- 6) The UE is switched on.
- 7) Enter the UE into loopback mode 1 looping back both the 12.2kbps RMC and HSDPA to E-DCH and start the loopback test. See TS34.108[3] clause 7.3.9 and TS34.109[4] clause 5.3.2.3 and 5.3.2.6 for details regarding loopback test mode for HSDPA and E-DCH. This way the UE is configured to transmit a data stream on the E-DPDCH with E-DPCCH. To fill the RLC transmit buffer, run the loopback for [3]s before starting the procedure.

- 8) Switch on the fading simulators

10.4.1A.4.2 Procedure

- 1) The SS shall signal 100% ACK on the E-HICH for all processes.
- 2) The SS shall signal the Absolute Grants according to the E-AGCH information sequence as defined in Table 10.4.1A.3.
- 3) The SS shall analyse the E-TFCI transmitted on the E-DPCCH for each E-DCH TTI to determine if a missed detection event has occurred by correlating the detected E-TFCIs with the expected E-TFCIs corresponding to the absolute grant sequence sent on E-AGCH. If the expected E-TFC is not detected by the SS, record a missed detection event.
- 4) The test shall be run such that statistical significance according to Annex F.6.4 is achieved.

Specific Message Contents

All messages indicated above shall use the same content as described in the default message content in clause 9.2.1 of 34.108 [3] with the following exceptions:

RADIO BEARER SETUP:

Information Element	Value/remark
E-DCH MAC-d flow maximum number of retransmissions	0

10.4.1A.5 Test Requirements

The missed detection probability shall not exceed to the values specified in Table 10.4.1A.5.

The missed detection probability = the ratio of (missed detection event)/ (all detected E-TFCI event) ≤ 0.01 .

Table 10.4.1A.3 and 10.4.1A.5 define the primary level settings including test tolerance and test parameters for the test.

Table 10.4.1A.3: Test parameters for E-AGCH detection – single link

Parameter	Unit	Missed detection
I_{oc}	dBm/3.84 MHz	-60
Phase reference	-	P-CPICH
P-CPICH E_c/I_{or}	dB	-10
E-AGCH information		The E-AGCH information sequence "AG ₄ AG ₈ AG ₁₀ AG ₄ AG ₈ AG ₁₀ ..." shall be transmitted continuously, where AG ₄ , AG ₈ and AG ₁₀ denote absolute grant index of 4, 8, 10 respectively
E-AGCH TTI length	ms	10
E-HICH E_c/I_{or}	dB	-20
β_c		15/15
β_d		5/15
β_{ns}		15/15

The exact mapping of the E-AGCH absolute grant indices and the expected E-TFCIs is shown in Table 10.4.1A.4. The mapping shall be used by the SS to compute the missed detection probability.

Table 10.4.1A.4: Mapping of the E-AGCH test sequence and the expected E-TFCI

Absolute Grant Index	Expected E-TFCI index
AG ₄	E-TFCI ₂₈
AG ₈	E-TFCI ₆₇
AG ₁₀	E-TFCI ₈₁
Note:	E-TFCI ₂₈ , E-TFCI ₆₇ E-TFCI ₈₁ denotes the E-TFC index of 28, 67 and 81 from 10ms TTI Table 0 in 25.321[13]. This mapping is based on the assumption that 1, 5 or 9 RLC PDUs of size 336 bits are used respectively.

Table 10.4.1A.5: Test requirement for E-AGCH detection – single link

Test Number	Propagation Conditions	Reference value		
		E-AGCH E_c / I_{or} (dB)	\hat{I}_{or} / I_{oc} (dB)	Miss detection probability
1	VA30	-26.7	0.6	0.01

11 Performance requirement (MBMS)

11.1 General

The performance requirements for the UE in this subclause are specified for the propagation conditions specified in Annex D.2 and the Downlink Physical channels specified in Annex E.5B.

Unless otherwise stated the receiver characteristics are specified at the antenna connector of the UE. For UEs with more than one receiver antenna connector the fading of the signals and the AWGN signals applied to each receiver antenna connector shall be uncorrelated. The levels of the test signal applied to each of the antenna connectors shall be as defined in the respective sections below.

A UE with one antenna connector may also fulfill the enhanced performance requirements Type 1. The levels of the test signal are applied to the single antenna connector as defined in the respective sections below.

11.2 Demodulation of MTCH

11.2.1 Definition and applicability

The receive characteristic of the MTCH is determined by RLC SDU error rate (RLC SDU ER). RLC SDU ER is specified for each individual data rate of the MTCH. The requirement is valid for all RRC states for which the UE has capabilities for MBMS.

The requirements and this test apply to Release 6 and later releases for all types of UTRA for the FDD UE that support MBMS.

Note: This test is incomplete.

11.2.2 Minimum requirement

For the parameters specified in Table 11.2.2.1 the average downlink S-CCPCH_ E_c / I_{or} power ratio shall be below the specified value for the RLC SDU ER shown in Table 11.2.2.2.

Table 11.2.2.1: Parameters for MTCH detection

Parameter	Unit	Test 1	Test 2	Test 3
Phase reference	-		P-CPICH	
I_{oc}	dBm/3.84 MHz	-60		
\hat{I}_{or}/I_{oc}	dB	-3	-3	-3
MTCH Data Rate		128 kbps	256 kbps	128 kbps
Transmission Time Interval	ms	40	40	80
Propagation condition		VA3		
Number of Radio Links p		3	3	3
Delay of Radio Link 2 compared with Radio Link 1		160ms	20 ms	20 ms
Delay of Radio Link 3 compared with Radio Link 1		1240ms	40.67 ms (1 TTI + 1 slot)	80.67 ms (1 TTI + 1 slot)

Table 11.2.2.2: Test requirements for MTCH detection

Test Number	S-CCPCH E_c/I_{or} (dB)	RLC SDU ER
1	-4.9	0.1
2	-5.6	0.1
3	-8.5	0.1

11.2.3 Test Purpose

The aim of the test is to verify that the RLC SDU error rate (RLC SDU ER) for each individual data rate of the MTCH channel does not exceed 0.1. The test shall be performed in CELL_PCH state only.

11.2.4 Method of test

11.2.4.1 Initial conditions

- 1) Connect the SS and AWGN noise source and fading simulator to the UE antenna connector as shown in Figure A.23.
- 2) The DL Reference Measurement Channel parameters are defined in Annex C.12.1.
- 3) The configuration for the downlink channel for each radio link is defined in Annex.E.5B.
- 4) The same MTCH data shall be sent in all radio links during the test.
- 5) The UE is switched on.
- 6) The UE is interested in the broadcast service provided by the SS, this service is included in the MBMS_ACTIVATED_SERVICES variable.
- 7) Set up a call according to the generic call setup procedure in TS34.108 [3] clause 7.3.10 with transition to the CELL_PCH state.
- 8) Setup the test parameter for Test 1-3 as specified in Table 11.2.5.1 and 11.2.5.2. Set up fading simulator as per the fading condition VA3, which is described in table D.2.2.1C.
- 9) Enter the UE into loopback test mode 3. See TS 34.108 and TS 34.109 for details regarding loopback test mode 3 for MBMS.
- 10) Switch on the fading simulator.

11.2.4.2 Procedure

- 1) SS shall start the test by sending data on the MTCH radio bearer and maintain the count of transmitted RLC SDU blocks on the MTCH.

- 2) SS shall send a "UE TEST LOOP MODE 3 RLC SDU COUNTER REQUEST" message and wait for the UE to response with a "UE TEST LOOP MODE 3 RLC SDU COUNTER RESPONSE" reporting the received RLC SDU counter value.
- 3) SS shall compute the RLC SDU error rate based on the transmitted RLC SDUs count and received RLC SDU count reported by the UE.
- 4) The test shall be run until the statistical significance according to Annex to F.6.1.8 is achieved.

11.2.5 Test Requirements

Table 11.2.5.1: Parameters for MTCH detection

Parameter	Unit	Test 1	Test 2	Test 3
Phase reference	-	P-CPICH		
I_{oc}	dBm/3.84 MHz	-60		
\hat{I}_{or}/I_{oc}	dB	-2.4	-2.4	-2.4
MTCH Data Rate		128 kbps	256 kbps	128 kbps
Transmission Time Interval	ms	40	40	80
Propagation condition		VA3		
Number of Radio Links p		3	3	3
Delay of Radio Link 2 compared with Radio Link 1		160ms	20 ms	20 ms
Delay of Radio Link 3 compared with Radio Link 1		1240ms	40.67 ms (1 TTI + 1 slot)	80.67 ms (1 TTI + 1 slot)

Table 11.2.5.2: Test requirements for MTCH detection

Test Number	S-CCPCH_Ec/lor (dB)	RLC SDU ER
1	-4.8	0.1
2	-5.5	0.1
3	-8.4	0.1

The RLC SDU error rate (RLC SDU ER) for all the MTCH demodulation tests shall not exceed the value specified in 11.2.5.2 for the specified $\frac{S-CCPCH_Ec}{I_{or}}$.

The RLC SDU error rate = the ratio of (transmitted RLC SDU count – received RLC SDU count) / (transmitted RLC SDU count) < 0.1.

NOTE: If the above Test Requirement differs from the Minimum Requirement then the Test Tolerance applied for this test is non-zero. The Test Tolerance for this test is defined in clause F.2 and the explanation of how the Minimum Requirement has been relaxed by the Test Tolerance is given in clause F.4.

11.2A Demodulation of MTCH - Enhanced Performance Requirements Type 1

11.2A.1 Definition and applicability

The receive characteristic of the MTCH is determined by RLC SDU error rate (RLC SDU ER). RLC SDU ER is specified for each individual data rate of the MTCH. The requirement is valid for all RRC states for which the UE has capabilities for MBMS.

The requirements and this test apply to Release 7 and later releases for all types of UTRA for the FDD UE that support MBMS and enhanced receiver type 1.

Note: This test is incomplete.

11.2A.2 Minimum requirement

For the parameters specified in Table 11.2A.2.1 the average downlink S-CCPCH_{E_c} / I_{or} power ratio shall be below the specified value for the RLC SDU ER shown in Table 11.2A.2.2.

Table 11.2A.2.1: Parameters for MTCH detection

Parameter	Unit	Test 1	Test 2	Test 3
Phase reference	-	P-CPICH		
I_{oc}	dBm/3.84 MHz	-60		
\hat{I}_{or}/I_{oc}	dB	-3	-3	-3
MTCH Data Rate		128 kbps	256 kbps	128 kbps
Transmission Time Interval	ms	40	40	80
Propagation condition		VA3		
Number of Radio Links p		3	3	3
Delay of Radio Link 2 compared with Radio Link 1		160ms	20 ms	20 ms
Delay of Radio Link 3 compared with Radio Link 1		1240ms	40.67 ms (1 TTI + 1 slot)	80.67 ms (1 TTI + 1 slot)

Table 11.2A.2.2: Test requirements for MTCH detection for UE supporting the enhanced performance requirements type1

Test Number	S-CCPCH _{E_c} /I _{or} (dB)	RLC SDU ER
1	-7.7	0.1
2	-8.7	0.1
3	-11.5	0.1

11.2A.3 Test Purpose

The aim of the test is to verify that the RLC SDU error rate (RLC SDU ER) for each individual data rate of the MTCH channel does not exceed 0.1. The test shall be performed in CELL_PCH state only.

11.2A.4 Method of test

11.2A.4.1 Initial conditions

- 1) Connect the SS and AWGN noise source and fading simulators to the UE antenna connector as shown in [FFS].
- 2) The DL Reference Measurement Channel parameters are defined in Annex C.12.1.
- 3) The configuration for the downlink channel for each radio link is defined in Annex.E.5B.
- 4) The same MTCH data shall be sent in all radio links during the test.
- 5) The UE is switched on.
- 6) The UE is interested in the broadcast service provided by the SS, this service is included in the MBMS_ACTIVATED_SERVICES variable.
- 7) Set up a call according to the generic call setup procedure in TS34.108 [3] clause 7.3.10 with transition to the CELL_PCH state.
- 8) Setup the test parameter for Test 1-3 as specified in Table 11.2A.5.1 and 11.2A.5.2. Set up fading simulators as per the fading condition VA3, which is described in table D.2.2.1C.
- 9) Enter the UE into loopback test mode 3. See TS 34.108 and TS 34.109 for details regarding loopback test mode 3 for MBMS.
- 10) Switch on the fading simulator.

11.2A.4.2 Procedure

- 1) SS shall start the test by sending data on the MTCH radio bearer and maintain the count of transmitted RLC SDU blocks on the MTCH.
- 2) SS shall send a "UE TEST LOOP MODE 3 RLC SDU COUNTER REQUEST" message and wait for the UE to response with a "UE TEST LOOP MODE 3 RLC SDU COUNTER RESPONSE" reporting the received RLC SDU counter value.
- 3) SS shall compute the RLC SDU error rate based on the transmitted RLC SDUs count and received RLC SDU count reported by the UE.
- 4) The test shall be run until the statistical significance according to Annex to F.6.1.8 is achieved.

Specific Message Contents

All messages indicated above shall use the same content as described in the default message content in clause 7.3.10 of 34.108 [3].

11.2A.5 Test Requirements

Table 11.2A.5.1: Parameters for MTCH detection

Parameter	Unit	Test 1	Test 2	Test 3
Phase reference	-	P-CPICH		
I_{oc}	dBm/3.84 MHz	-60		
\hat{I}_{or}/I_{oc}	dB	-2.4	-2.4	-2.4
MTCH Data Rate		128 kbps	256 kbps	128 kbps
Transmission Time Interval	ms	40	40	80
Propagation condition		VA3		
Number of Radio Links p		3	3	3
Delay of Radio Link 2 compared with Radio Link 1		160ms	20 ms	20 ms
Delay of Radio Link 3 compared with Radio Link 1		1240ms	40.67 ms (1 TTI + 1 slot)	80.67 ms (1 TTI + 1 slot)

Table 11.2A.5.2: Test requirements for MTCH detection for UE supporting the enhanced performance requirements type1

Test Number	S-CCPCH E_c/I_{or} (dB)	RLC SDU ER
1	-7.6	0.1
2	-8.6	0.1
3	-11.4	0.1

The RLC SDU error rate (RLC SDU ER) for all the MTCH demodulation tests shall not exceed the value specified in 11.2A.5.2 for the specified $\frac{S-CCPCH_E_c}{I_{or}}$.

The RLC SDU error rate = the ratio of (transmitted RLC SDU count – received RLC SDU count) / (transmitted RLC SDU count) < 0.1.

NOTE: If the above Test Requirement differs from the Minimum Requirement then the Test Tolerance applied for this test is non-zero. The Test Tolerance for this test is defined in clause F.2 and the explanation of how the Minimum Requirement has been relaxed by the Test Tolerance is given in clause F.4.

11.3 Demodulation of MTCH and cell identification

11.3.1 Definition and applicability

MBMS combining is not controlled by a network but instead it is autonomously handled by a terminal. UE has to be able to receive MTCH and identify intra-frequency neighbour cells according to the requirements. The receive characteristic of the MTCH combined with cell identification is determined by RLC SDU error rate (RLC SDU ER).

The requirements and this test apply to Release 6 and later releases for FDD UE that supports MBMS.

Editor's note: This test is incomplete.

11.3.2 Minimum requirements

For the parameters specified in Table 11.3.2.1 the average downlink S-CCPCH_Ec/I_{or} power ratio shall be below the specified value for the RLC SDU error rate shown in Table 11.3.2.2. The cell reselection parameters are given in clause in Table 11.3.2.3. The different cells are assumed to be time aligned.

Table 11.3.2.1: Parameters for MTCH demodulation requirements with cell identification

Parameter	Unit	Test 1		
		Stage 1	Stage 2	Stage 2
Time in each stage	S	2	0.8	2
Phase reference	-	P-CPICH		
I_{oc}	dBm/3.84 MHz	-70	-73	-70
Cell1 \hat{I}_{or1}/I_{oc}	dB	-3	0	-3
Cell2 \hat{I}_{or2}/I_{oc}	dB	-3	0	-infinity
Cell3 \hat{I}_{or3}/I_{oc}	dB	-infinity	0	-3
Propagation condition		Case1		
MTCH Data Rate	Kbps	128		
Number of Radio Links		2	3	2

Table 11.3.2.2: Requirements for MTCH detection

Test Number	S-CCPCH_Ec/I _{or} (dB)	RLC SDU ER
1	-5.6	0.05

Parameters for combined MTCH demodulation and cell identification requirements are defined in Table 11.3.2.3.

Table 11.3.2.3: Cell reselection parameters

Parameter	Unit	Value
Serving cell in the initial condition		Cell1
Neighbour cells		32 intra-frequency neighbour cells are indicated including Cell2 and Cell3
Cell_selection_and_reselection_quality_measure		CPICH E _c /N ₀
Qqualmin	dB	-20
Qrxlevmin	dBm	-115
UE_TXPWR_MAX_RACH	dB	21
Qhyst2	dB	20 dB
Treselection	Seconds	4
Sintrasearch	dB	not sent
IE "FACH Measurement occasion info"		not sent

The reference for this requirement is TS 25.101 [1] clause 11.3.1 and TS 25.101 [1] annex A.9.

11.3.3 Test purpose

To verify that the SDU error rate does not exceed the value at the S-CCPCH_Ec/Ior specified in table 11.3.2.2.

11.3.4 Method of test

11.3.4.1 Initial conditions

Test environment: normal; see clauses G.2.1 and G.2.2.

Frequencies to be tested: mid range; see clause G.2.4.

- 1) Connect the SS and AWGN noise source and fading simulators to the UE antenna connector as shown in Figure A.23.
- 2) The DL Reference Measurement Channel parameters are defined in Annex C.12.1.
- 3) The configuration for the downlink channel for each radio link is defined in Annex.E.5B.1.
- 4) The same MTCH data shall be sent in all active cells during the test.
- 5) The UE is switched on.
- 6) The UE selects the broadcast service provided by the SS (included in the MBMS_ACTIVATED_SERVICES variable).
- 7) Set up a call according to the generic call setup procedure specified in TS 34.108 [3] clause 7.3.10 to configure and activate an MBMS session with transition to CELL_PCH state. The SS broadcast the cell reselection parameters according to table 11.3.2.3.

11.3.4.2 Procedures

- 1) The SS configures and activates cell 1 to 3 with RF parameters according to Stage 1 conditions in Table 11.3.2.1.
- 2) The SS transmits valid MAC headers and RLC SDUs on the MTCH radio bearer for 2 seconds. The SS counts the number of transmitted RLC SDUs on the MTCH with valid MAC headers (N_{SS_Stage1}).
- 3) The SS transmits invalid MAC headers sets the test parameters for Cell 1, Cell 2 and Cell 3 as specified in table 11.3.2.1 and Stage 2.
- 4) The SS transmits valid MAC headers and RLC SDUs on the MTCH radio bearer for 0.8 seconds. The SS counts the number of transmitted RLC SDUs on the MTCH with valid MAC headers (N_{SS_Stage2}).
- 5) The SS transmits invalid MAC headers sets the test parameters for Cell 1, Cell 2 and Cell 3 as specified in table 11.3.2.1 and Stage 3.
- 6) The SS transmits valid MAC headers and RLC SDUs on the MTCH radio bearer for 2 seconds. The SS counts the number of transmitted RLC SDUs on the MTCH with valid MAC headers (N_{SS_Stage3}).
- 7) Repeat step 9) to 14) until the confidence level for RLC SDU's according to annex F.6.1.8.
- 8) The SS transmits a PAGING TYPE 1 message to the UE on the PCH and the UE moves to CELL_FACH state, sending a CELL UPDATE message. The SS replies with a CELL UPDATE CONFIRM message.
- 9) The UE confirms the received C-RNTI to be used in CELL FACH state by transmitting a UTRAN MOBILITY INFORMATION CONFIRM message on the uplink DCCH.
- 10) The SS sends a "UE TEST LOOP MODE 3 RLC SDU COUNTER REQUEST" message.
- 11) The SS waits for the UE to respond by a "UE TEST LOOP MODE 3 RLC SDU COUNTER RESPONSE" message reporting the number of received RLC SDUs on MTCH (N_{UEOK}).
- 12) The SS in Cell 1 calculates the SDU error rate as: (Number of SS transmitted RLC SDUs – UE received RLC SDUs) / Number of SS transmitted RLC SDUs; where Number of SS transmitted RLC SDUs = $N_{SS_Stage1} + N_{SS_Stage2} + N_{SS_Stage3}$; and UE received RLC SDUs = N_{UEOK} .

13) End the RRC connection according to the generic call setup procedure specified in TS 34.108 [3] clause 7.3.10.

Specific Message Contents

All messages indicated above shall use the same content as described in the default message content in clause 9 of 34.108 [3].

11.3.5 Test requirements

The test parameters are specified in table 11.3.5.1.

Table 11.3.5.1: Parameters for MTCH demodulation requirements with cell identification

Parameter	Unit	Test 1		
		Stage 1	Stage 2	Stage 2
Time in each stage	S	2	0.8	2
Phase reference	-	P-CPICH		
I_{oc}	dBm/3.84 MHz	-70	-73	-70
Cell1 \hat{I}_{or1}/I_{oc}	dB	-2.4	0.6	-2.4
Cell2 \hat{I}_{or2}/I_{oc}	dB	-2.4	0.6	-infinity
Cell3 \hat{I}_{or3}/I_{oc}	dB	-infinity	0.6	-2.4
Propagation condition		Case1		
MTCH Data Rate	Kbps	128		
Number of Radio Links		2	3	2

The RLC SDU ER shall not exceed the value specified in table 11.3.5.2 for the specified $\frac{S - CCPCH_Ec}{I_{or}}$.

Table 11.3.5.2: Requirements for MTCH detection

Test Number	S-CCPCH_Ec/I _{or} (dB)	RLC SDU ER
1	-5.5	0.05

NOTE: If the above Test Requirement differs from the Minimum Requirement then the Test Tolerance applied for this test is non-zero. The Test Tolerance for this test is defined in clause F.2 and the explanation of how the Minimum Requirement has been relaxed by the Test Tolerance is given in clause F.4.

Annex A (informative): Connection Diagrams

Definition of Terms

System Simulator or SS – A device or system, that is capable of generating simulated Node B signalling and analysing UE signalling responses on one or more RF channels, in order to create the required test environment for the UE under test. It will also include the following capabilities:

1. Measurement and control of the UE Tx output power through TPC commands
2. Measurement of Rx BLER and BER
3. Measurement of signalling timing and delays
4. Ability to simulate UTRAN and/or GERAN signalling

Test System – A combination of devices brought together into a system for the purpose of making one or more measurements on a UE in accordance with the test case requirements. A test system may include one or more System Simulators if additional signalling is required for the test case. The following diagrams are all examples of Test Systems.

Note: The above terms are logical definitions to be used to describe the test methods used in this document (TS34.121), in practice, real devices called 'System Simulators' may also include additional measurement capabilities or may only support those features required for the test cases they are designed to perform.

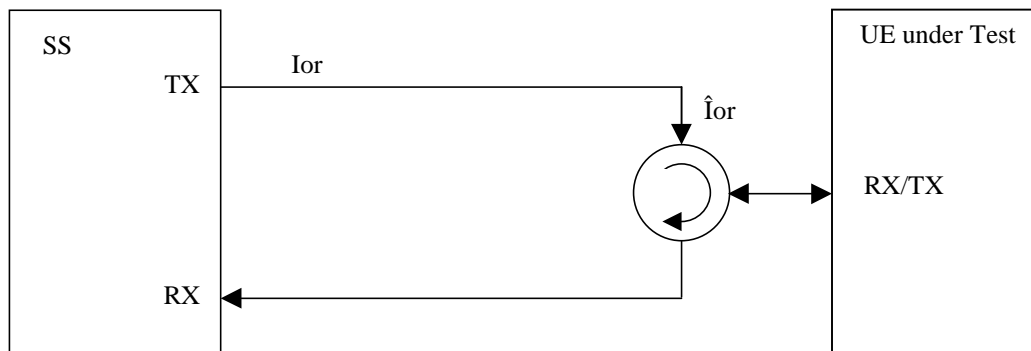

Figure A.1: Connection for basic single cell tests

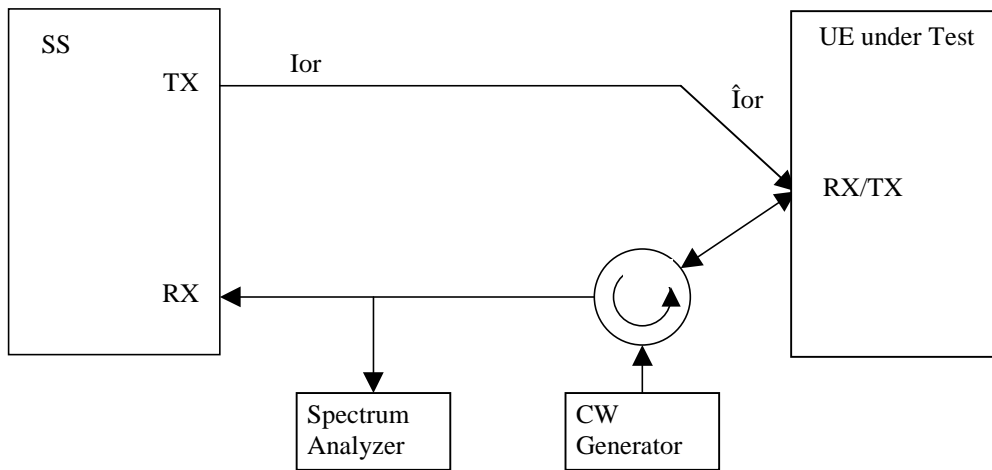

Figure A.2: Connection for Transmitter Intermodulation tests

Figure A.3: Void

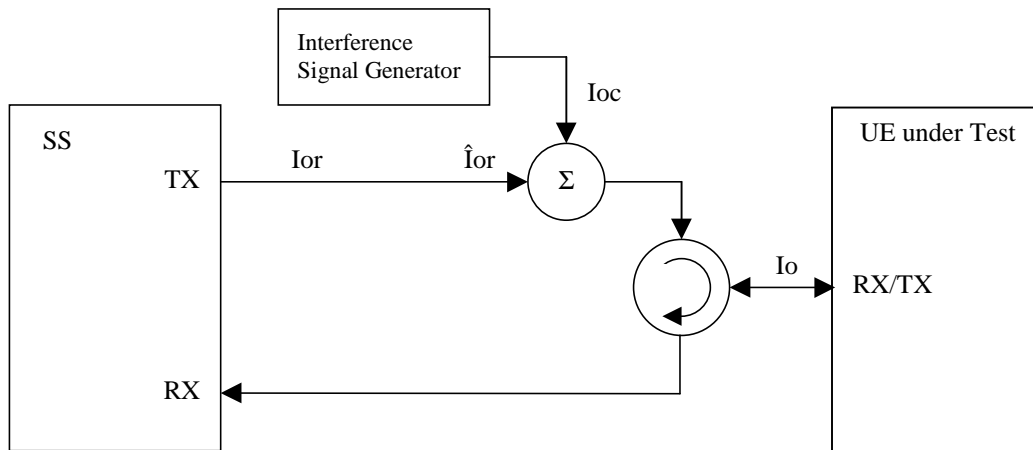

Figure A.4: Connection for Receiver tests with Interference

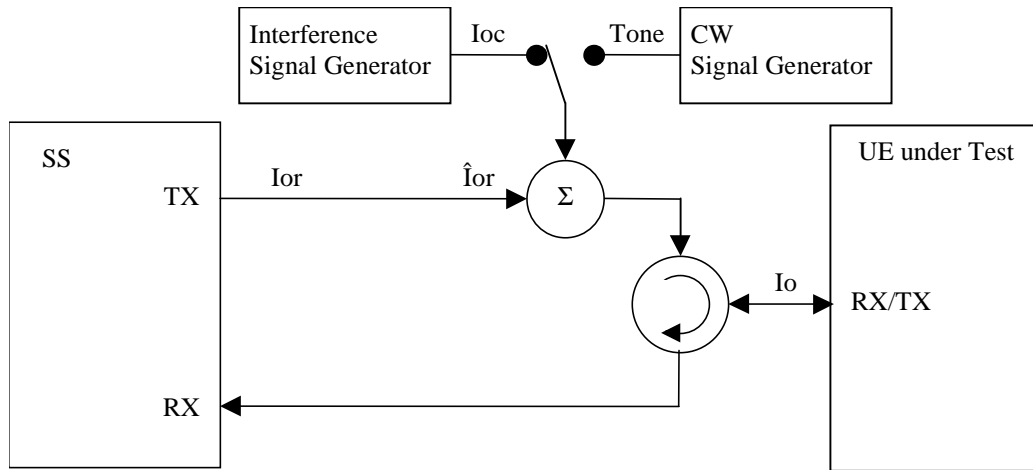

Figure A.5: Connection for Receiver tests with Interference or additional CW signal

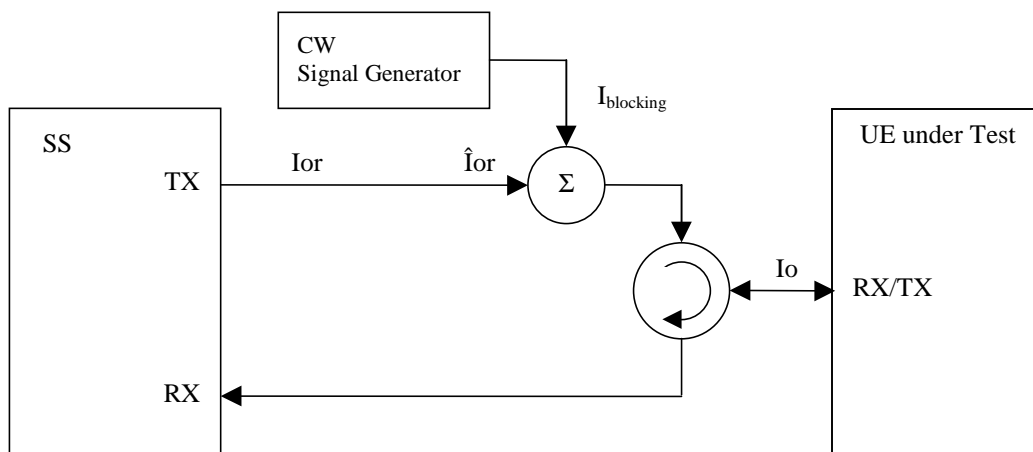

Figure A.6: Connection for Receiver tests with additional CW signal

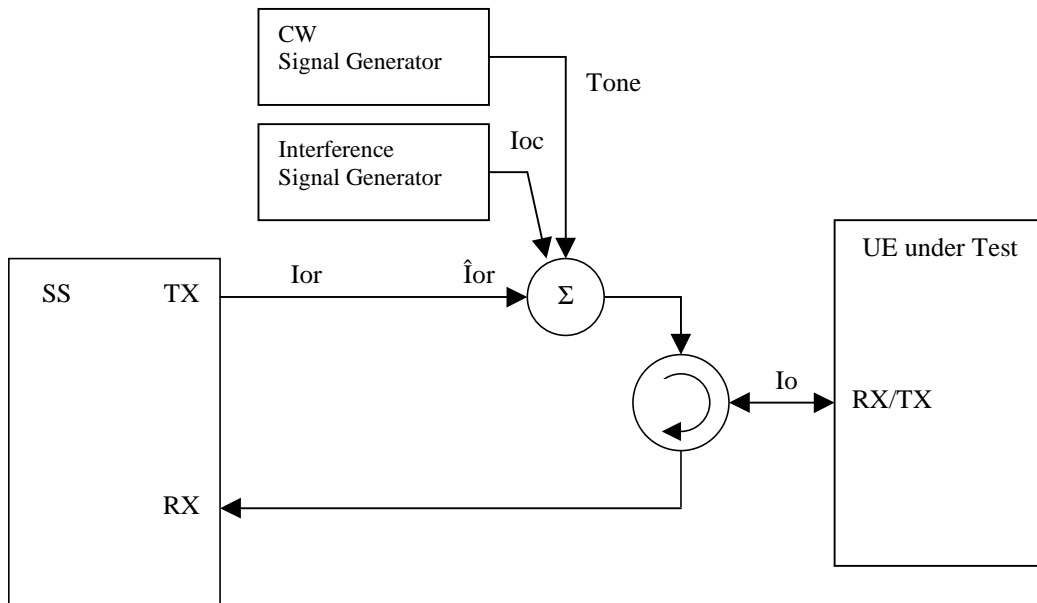

Figure A.7: Connection for Receiver tests with both Interference and additional CW signal

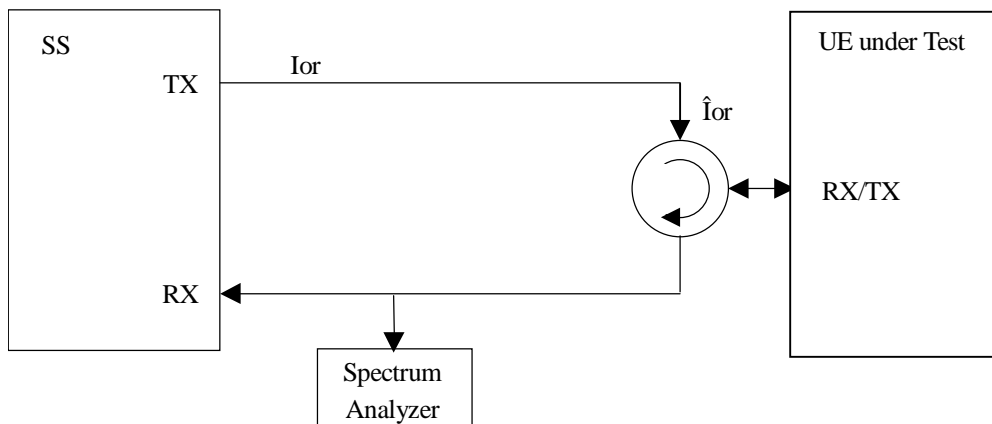

Figure A.8: Connection for tests with additional Spectrum Analyzer

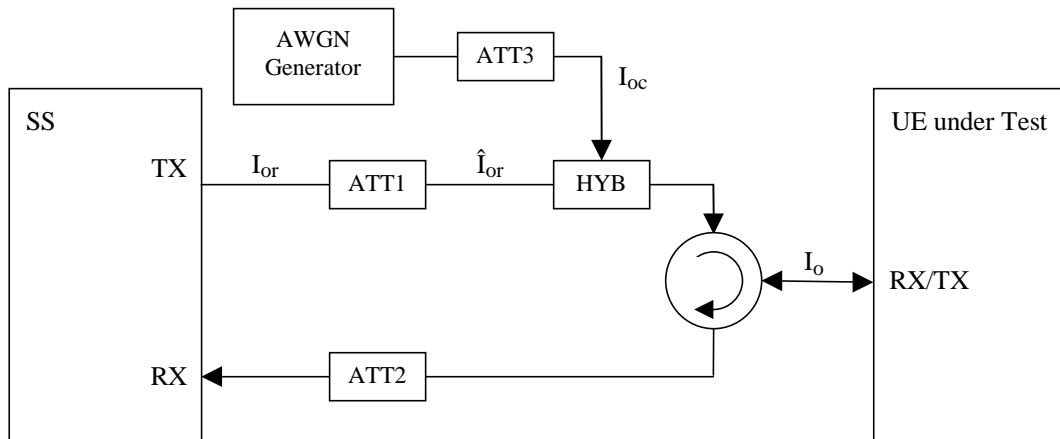

Figure A.9: Connection for single cell tests with static propagation

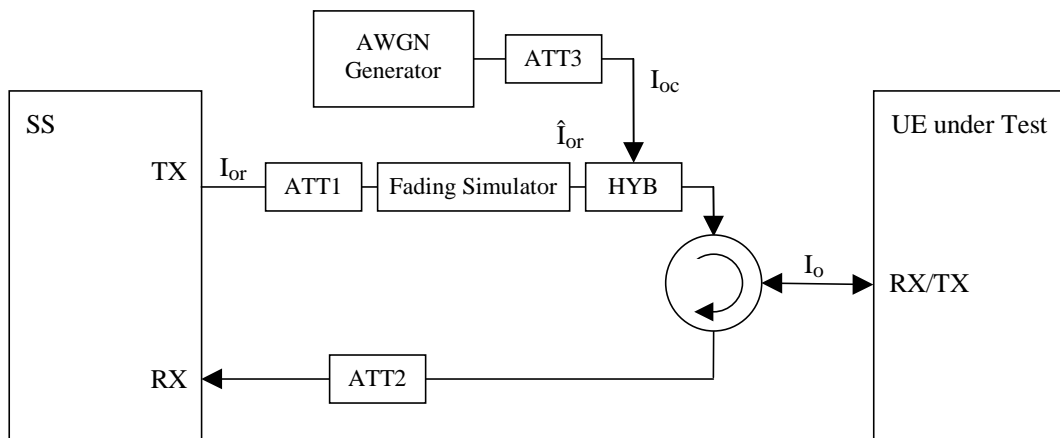

Figure A.10: Connection for single cell tests with Multi-path Fading propagation

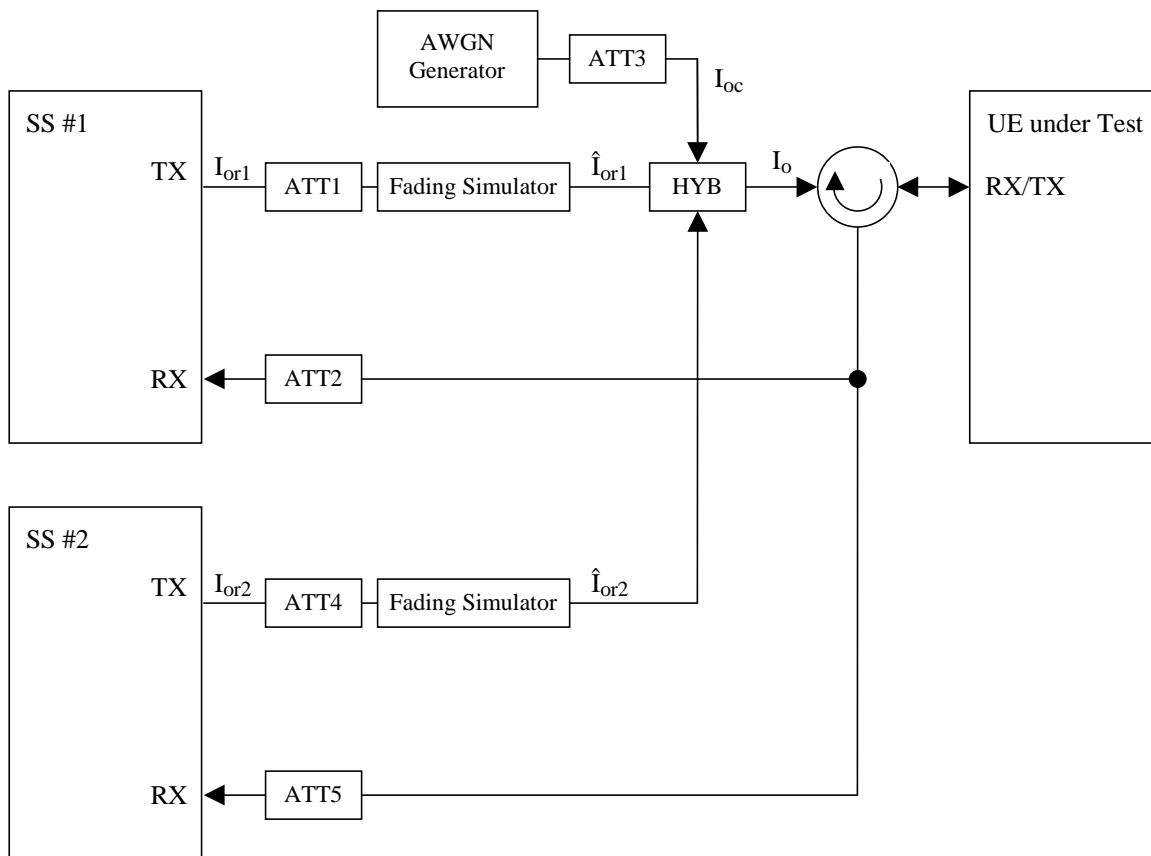

Figure A.11: Connection for two cell tests with Multi-path Fading propagation

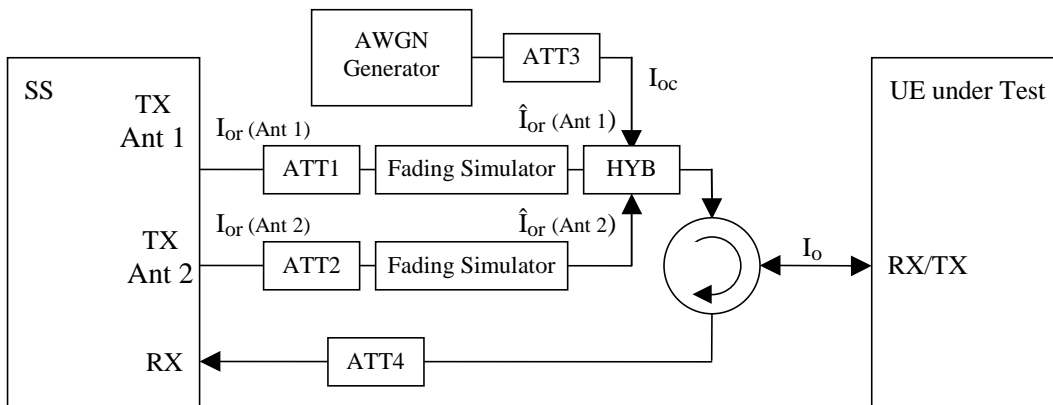

Figure A.12: Connection for single cell tests with Multi-path Fading propagation and transmit diversity

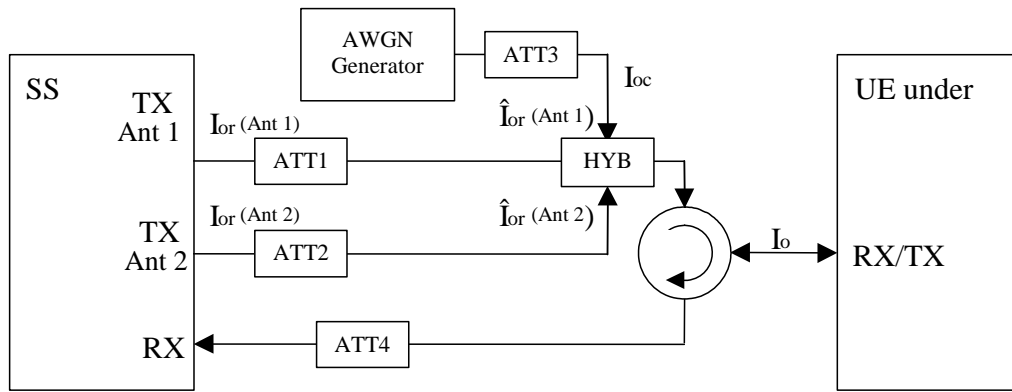

Figure A.12a: Connection for single cell tests with static propagation and transmit diversity

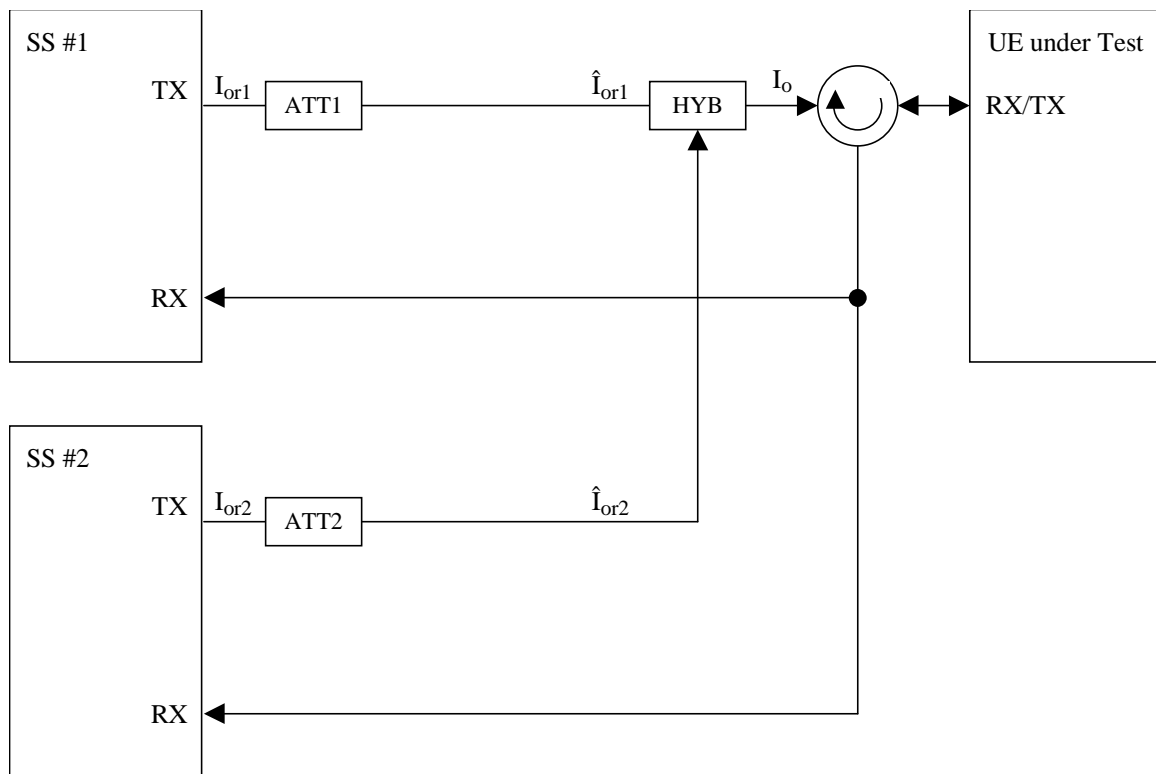

Figure A.13: Connection for basic two cell tests

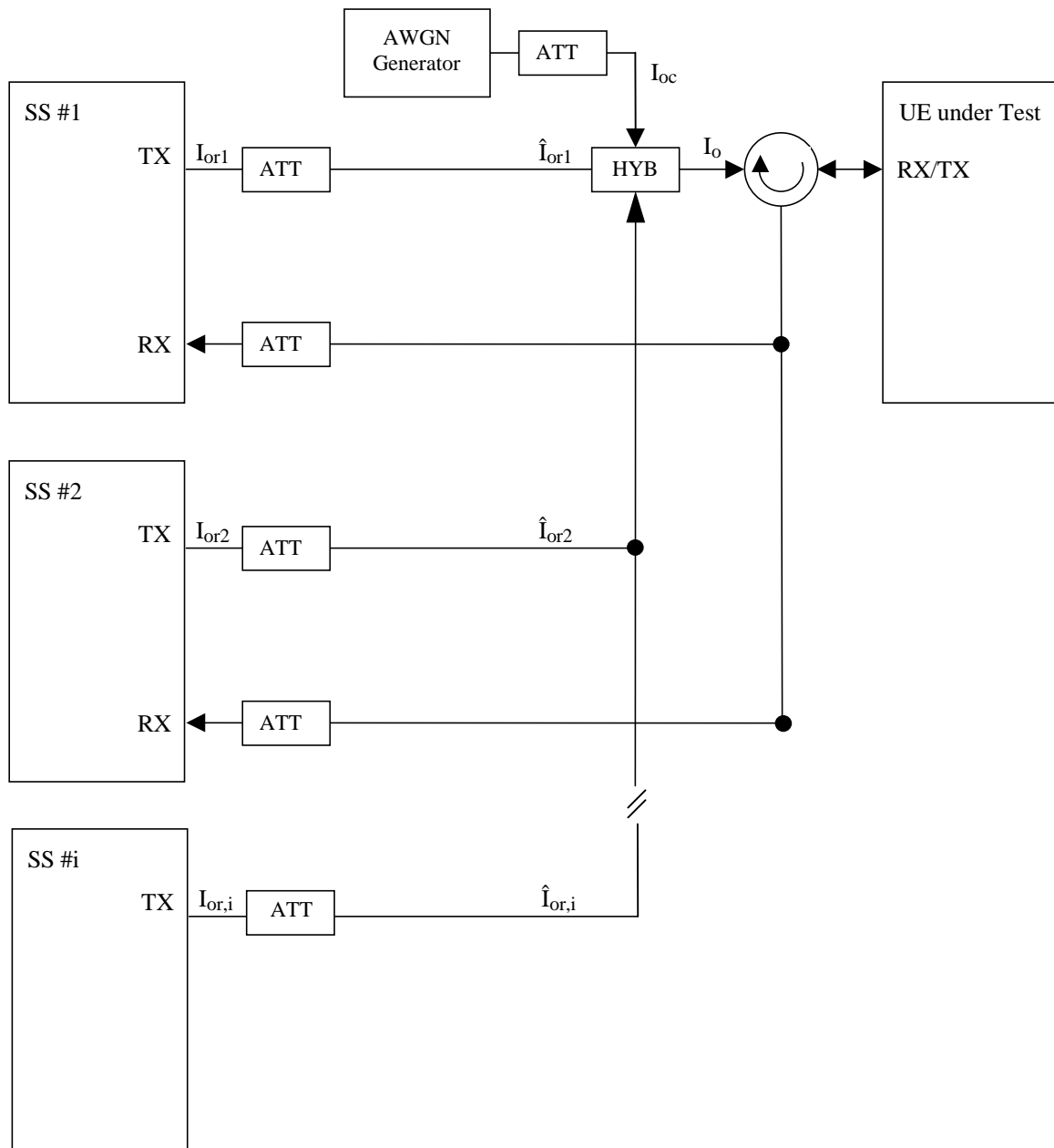

Figure A.14: Connection for multi-cell tests with static propagation

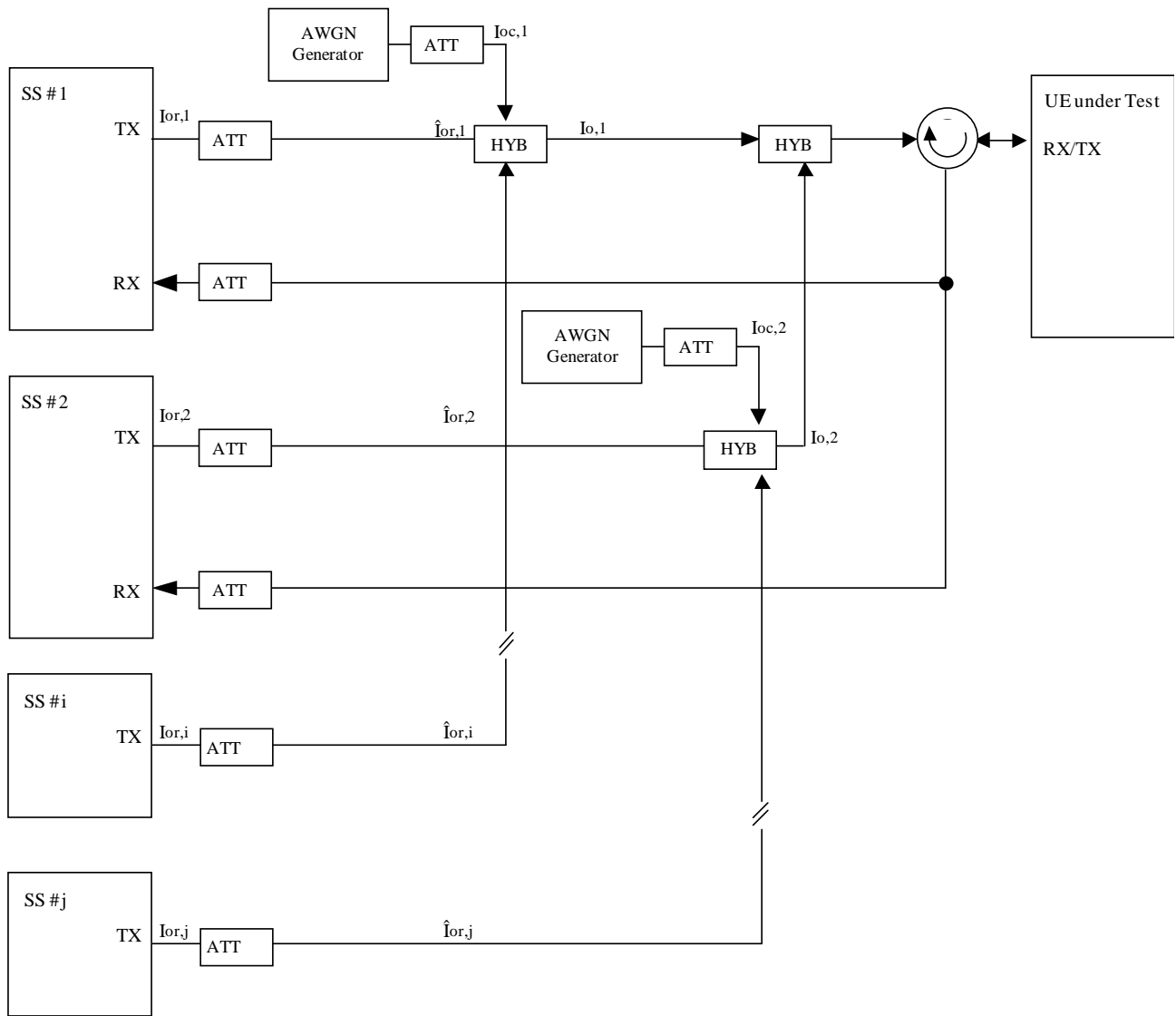

Figure A.15: Connection for multi-carrier, multi-cell tests with static propagation

Figure A.16: Void

Figure A.17: Void

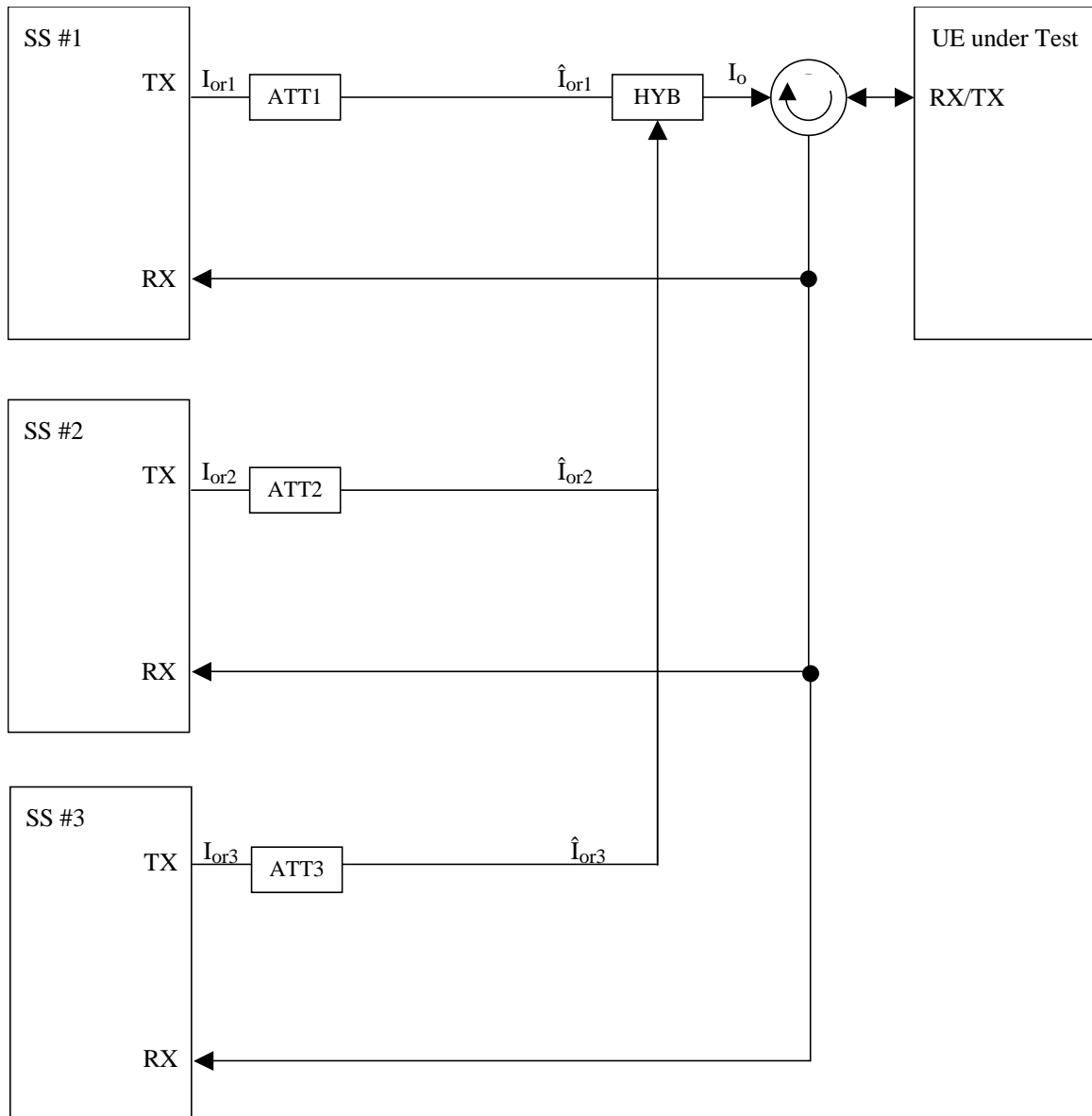

Figure A.18: Connection for basic three cell tests

Figure A.19: Void

Figure A.20: Void

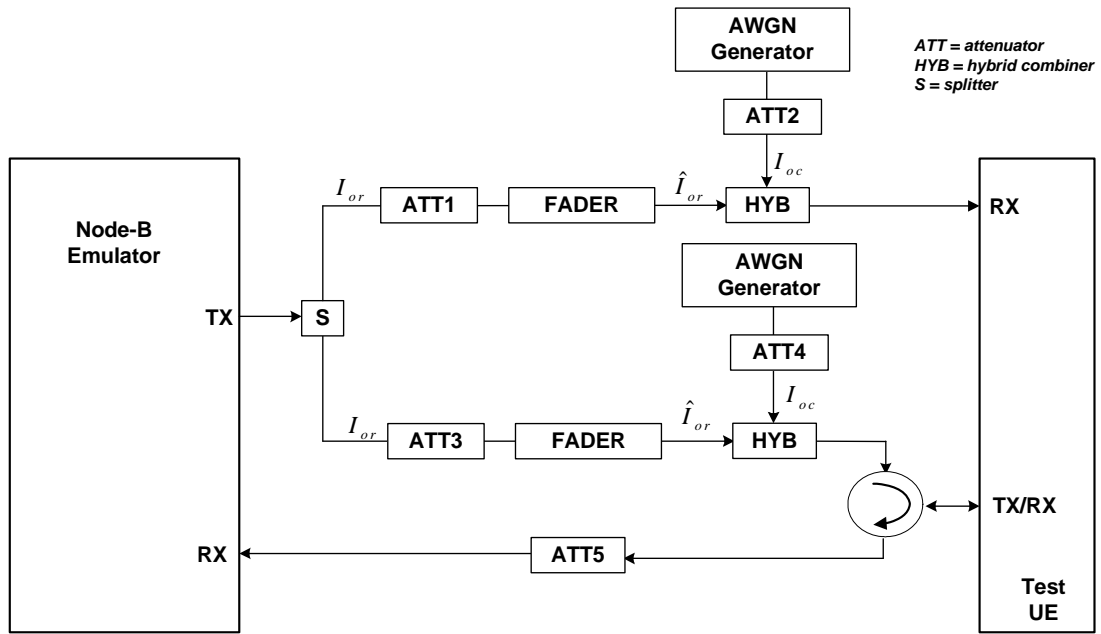

Figure A.21: Connection for single cell tests with Multi-path Fading propagation and UE receive diversity

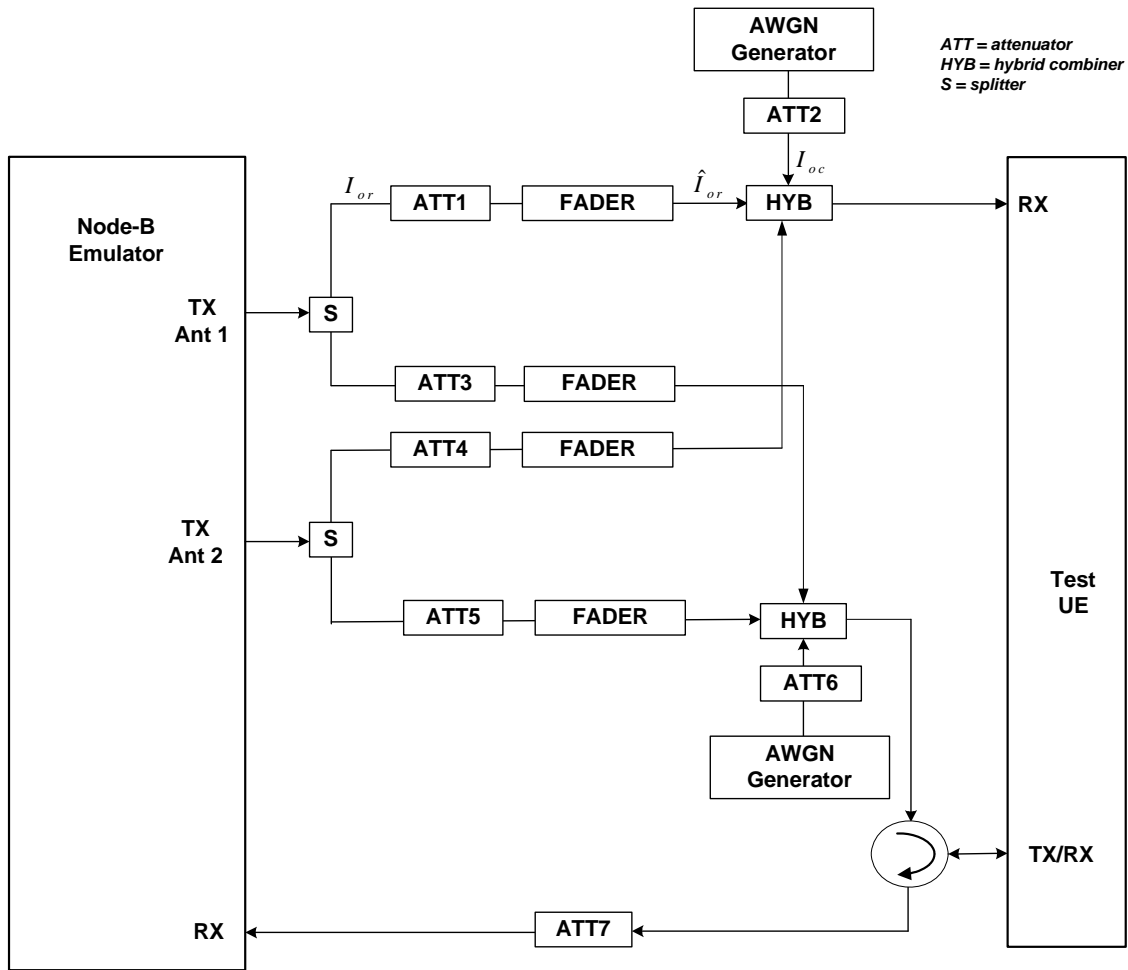

Figure A.22: Connection for single cell tests with Multi-path Fading propagation, transmit diversity and UE receive diversity

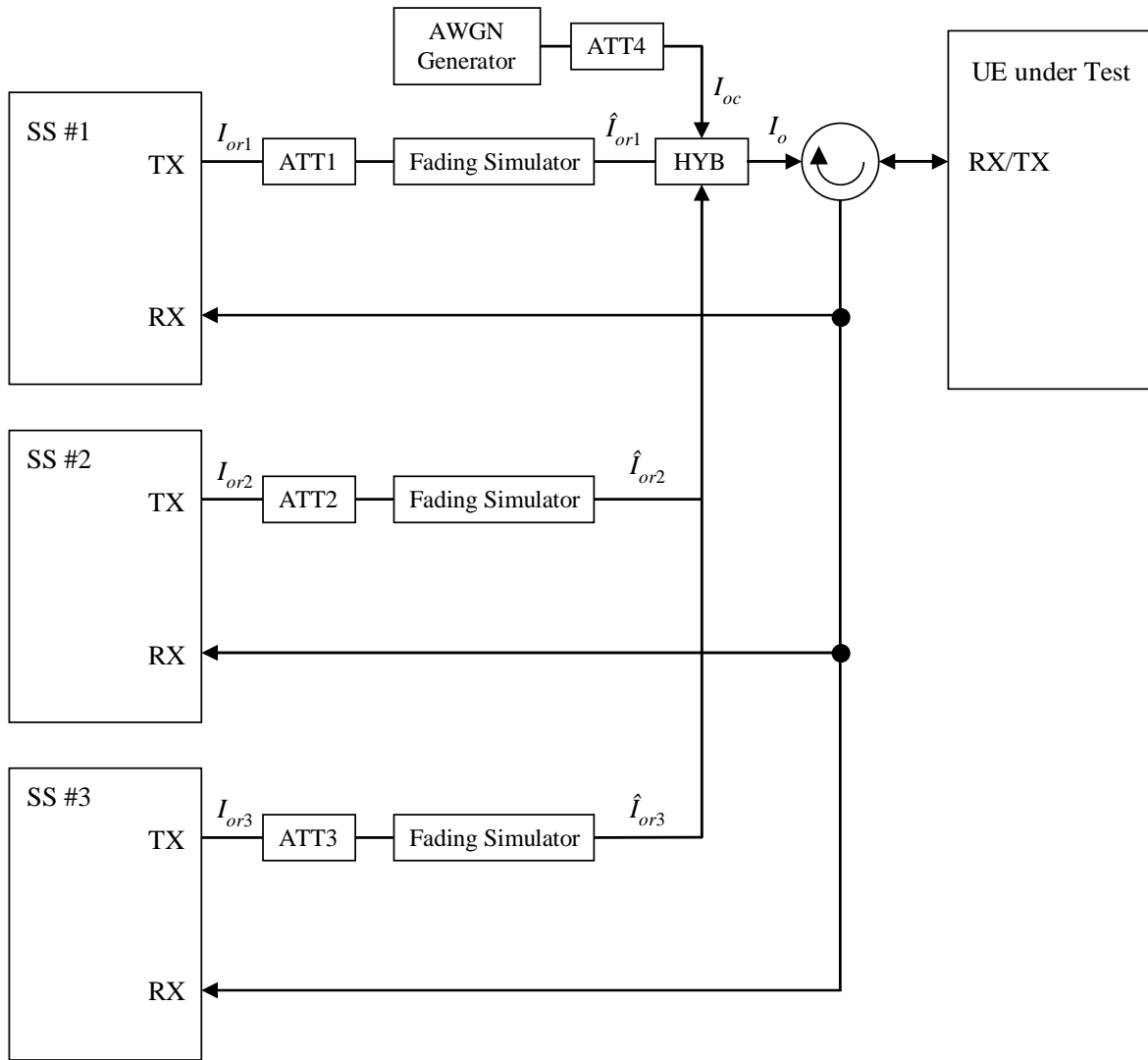

Figure A.23: Connection for three cell tests with Multi-path Fading propagation

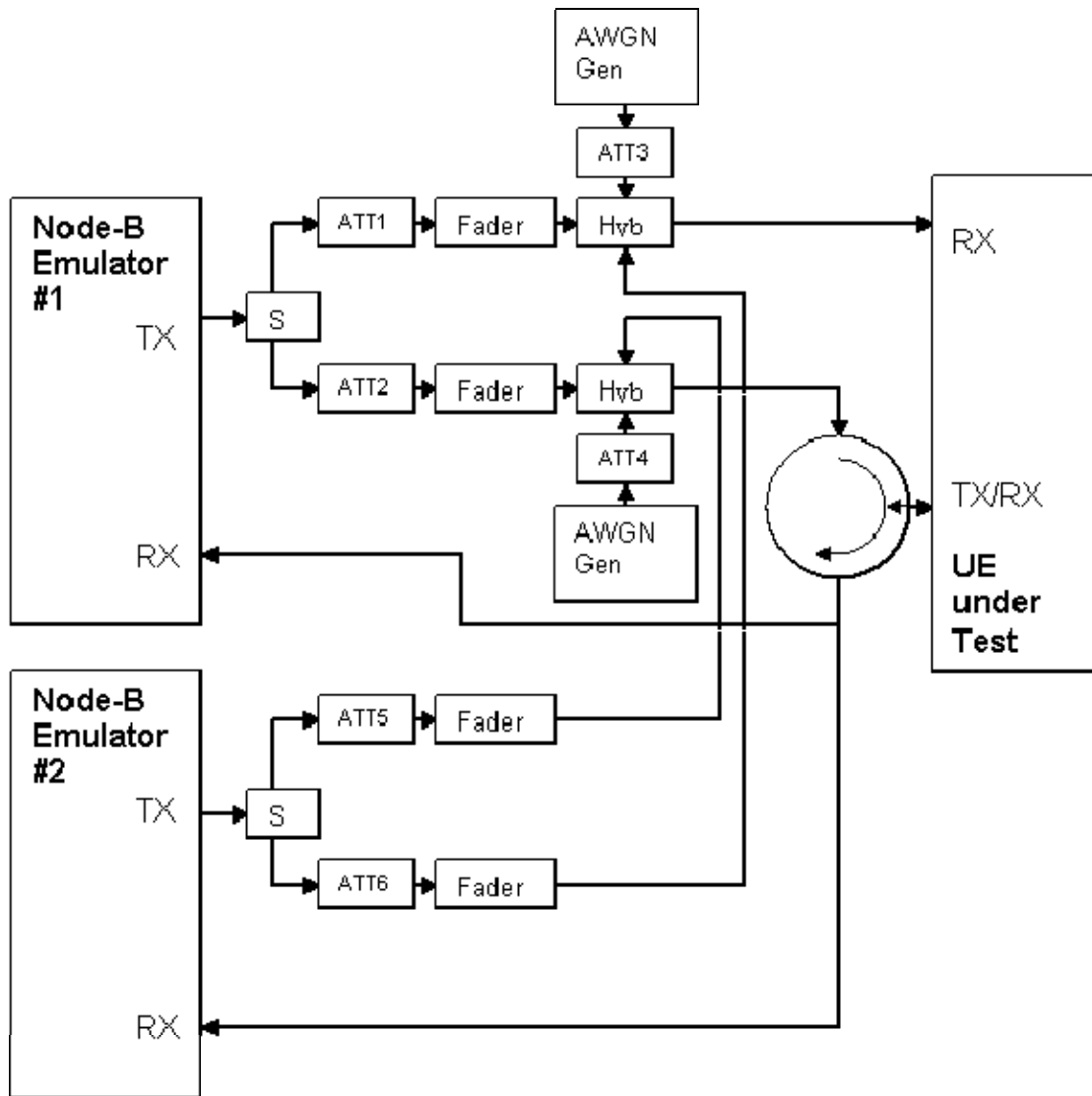

Figure A.24: Connection for two cell tests with Multi-path Fading propagation and UE receive diversity

Annex B (normative): Global In-Channel TX-Test

B.1 General

The global in-channel Tx test enables the measurement of all relevant parameters that describe the in-channel quality of the output signal of the Tx under test in a single measurement process.

The parameters describing the in-channel quality of a transmitter, however, are not necessarily independent. The algorithm chosen for description inside this annex places particular emphasis on the exclusion of all interdependencies among the parameters. Any other algorithm (e.g. having better computational efficiency) may be applied, as long as the results are the same within the acceptable uncertainty of the test system as defined in annex F.

All notes referred in the various clauses of B.2 are put together in B.3.

B.2 Definition of the process

B.2.1 Basic principle

The process is based on the comparison of the actual **output signal of the TX under test**, received by an ideal receiver, with a **reference signal**, that is generated by the measuring equipment and represents an ideal error free received signal. The reference signal shall be composed of the same number of codes at the correct spreading factors as contained in the test signal. Note, for simplification, the notation below assumes only codes of one spreading factor although the algorithm is valid for signals containing multiple spreading factors. All signals are represented as equivalent (generally complex) baseband signals.

B.2.2 Output signal of the TX under test

The output signal of the TX under test is acquired by the measuring equipment, filtered by a matched filter (RRC 0.22, correct in shape and in position on the frequency axis) and stored for further processing.

The following form represents the physical signal in the entire measurement interval:

one vector **Z**, containing $N = ns \times sf$ complex samples;

with

ns: number of symbols in the measurement interval;

sf: number of chips per symbol. (sf: spreading factor) (see Note: Symbol length)

B.2.3 Reference signal

The reference signal is constructed by the measuring equipment according to the relevant TX specifications.

It is filtered by the same matched filter, mentioned in clause B.2.2., and stored at the Inter-Symbol-Interference free instants. The following form represents the reference signal in the entire measurement interval:

- one vector **R**, containing $N = ns \times sf$ complex samples;

- ns, sf: see clause B.2.2.

B.2.4 void

B.2.5 Classification of measurement results

The measurement results achieved by the global in-channel TX test can be classified into two types:

- Results of type "deviation", where the error-free parameter has a non-zero magnitude. (These are the parameters that quantify the integral physical characteristic of the signal). These parameters are:

RF Frequency;

Power (in case of single code);

Code Domain Power (in case of multi code);

Timing

(Additional parameters: see Note: Deviation).

- Results of type "residual", where the error-free parameter has value zero. (These are the parameters that quantify the error values of the measured signal, whose ideal magnitude is zero). These parameters are:

Error Vector Magnitude (EVM);

Peak Code Domain Error (PCDE).

(Additional parameters: see Note Residual)

B.2.6 Process definition to achieve results of type "deviation"

The reference signal (**R**; see clause B.2.3) and the signal under Test (**Z**; see subclause B.2.2) are varied with respect to the parameters mentioned in clause B.2.5 under "results of type deviation" in order to achieve best fit. Best fit is achieved when the RMS difference value between the varied signal under test and the varied reference signal is an absolute minimum.

Overview:

$$FCT [Z(\tilde{f}, \tilde{t}, \tilde{\varphi}, g_1, g_2, \dots, g_{synch}) - R(f, t, \varphi, \tilde{g}_1, \tilde{g}_2, \dots, \tilde{g}_{synch})] = Minimum !$$

Z: Signal under test.

R: Reference signal,

with frequency f , the timing t , the phase φ , gain of code1 (g_1), gain of code2 (g_2) etc, and the gain of the synch channel g_{synch} . See Note: Power Step.

The parameters marked with a tilde in Z and R are varied in order to achieve a best fit.

Detailed formula: see Note: Formula for the minimum process.

The varied reference signal, after the best fit process, will be called **R'**.

The varied signal under test, after the best fit process, will be called **Z'**.

The varying parameters, leading to **R'** and **Z'** represent directly the wanted results of type "deviation". These measurement parameters are expressed as deviation from the reference value with units same as the reference value.

In case of multi code, the type-"deviation"-parameters (frequency, timing and (RF-phase)) are varied commonly for all codes such that the process returns one frequency-deviation, one timing deviation, (one RF-phase –deviation).

(These parameters are not varied on the individual codes signals such that the process would return kr frequency errors... (kr: number of codes in the reference signal)).

The only type-"deviation"-parameters varied individually are the code domain gain factors (g_1, g_2, \dots).

B.2.6.1 Decision Point Power

The mean-square value of the signal-under-test, sampled at the best estimate of the of Intersymbol-Interference-free points using the process defined in subclause 2.5, is referred to the *Decision Point Power* (DPP):

$$DPP = mean(|Z'|^2)$$

B.2.6.2 Code-Domain Power

The samples, Z , are separated into symbol intervals to create n_s time-sequential vectors \mathbf{z} with sf complex samples comprising one symbol interval. The *Code Domain Power* is calculated according to the following steps:

- 1) Take the vectors \mathbf{z} defined above.
- 2) To achieve meaningful results it is necessary to descramble \mathbf{z} , leading to \mathbf{z}' (see Note1: Scrambling code)
- 3) Take the orthogonal vectors of the channelization code set \mathbf{C} (all codes belonging to one spreading factor) as defined in TS 25.213 and TS 25.223 (range +1, -1), and normalize by the norm of the vectors to produce $\mathbf{C}_{norm} = \mathbf{C}/\text{sqrt}(sf)$. (see Note: Symbol length)
- 4) Calculate the inner product of \mathbf{z}' with \mathbf{C}_{norm} . Do this for all symbols of the measurement interval and for all codes in the code space.
This gives an array of format $k \times n_s$, each value representing a specific symbol and a specific code, which can be exploited in a variety of ways.

k : total number of codes in the code space

n_s : number of symbols in the measurement interval

- 5) Calculate k mean-square values, each mean-square value unifying n_s symbols within one code. (These values can be called "*Absolute CodeDomainPower (CDP)*" [Volt²].) The sum of the k values of CDP is equal to DPP.
- 6) Normalize by the decision point power to obtain

$$\text{Relative CodeDomain Power} = \frac{\text{Absolute CodeDomain Power}}{\text{Decision Point Power}}$$

B.2.7 Process definition to achieve results of type "residual"

The difference between the varied reference signal (\mathbf{R}' ; see clause B.2.6.) and the varied TX signal under test (\mathbf{Z}' ; see clause B.2.6) is the error vector \mathbf{E} versus time:

$$\mathbf{E} = \mathbf{Z}' - \mathbf{R}'$$

Depending on the parameter to be evaluated, it is appropriate to represent \mathbf{E} in one of the following two different forms:

Form EVM (representing the physical error signal in the entire measurement interval)

One vector \mathbf{E} , containing $N = n_s \times sf$ complex samples;

n_s, sf : see B.2.2

Form PCDE (derived from Form EVM by separating the samples into symbol intervals)

n_s time-sequential vectors \mathbf{e} with sf complex samples comprising one symbol interval.

\mathbf{E} gives results of type "residual" applying the two algorithms defined in clauses B 2.7.1 and B 2.7.2.

B.2.7.1 Error Vector Magnitude (EVM)

The Error Vector Magnitude EVM is calculated according to the following steps:

- 1) Take the error vector \mathbf{E} defined in clause B.2.7 (Form EVM) and calculate the RMS value of \mathbf{E} ; the result will be called $\text{RMS}(\mathbf{E})$.
- 2) Take the varied reference vector \mathbf{R}' defined in clause B.2.6 and calculate the RMS value of \mathbf{R}' ; the result will be called $\text{RMS}(\mathbf{R}')$.
- 3) Calculate EVM according to:

$$EVM = \frac{RMS(\mathbf{E})}{RMS(\mathbf{R}')} \times 100\% \quad (\text{here, EVM is relative and expressed in \%})$$

(see Note: Formula for EVM)

B.2.7.2 Peak Code Domain Error (PCDE)

The Peak Code Domain Error is calculated according to the following steps:

- 1) Take the error vectors \mathbf{e} defined in clause B.2.7 (Form PCDE)
- 2) To achieve meaningful results it is necessary to descramble \mathbf{e} , leading to \mathbf{e}' (see Note1: Scrambling code)
- 3) Take the orthogonal vectors of the channelisation code set \mathbf{C} (all codes belonging to one spreading factor) as defined in TS 25.213 and TS 25.223 (range +1, -1). (see Note: Symbol length) and normalize by the norm of the vectors to produce $\mathbf{C}_{norm} = \mathbf{C}/\text{sqrt}(\text{sf})$. (see Note: Symbol length)
- 4) Calculate the inner product of \mathbf{e}' with \mathbf{C}_{norm} . Do this for all symbols of the measurement interval and for all codes in the code space.
This gives an array of format $k \times n_s$, each value representing an error-vector representing a specific symbol and a specific code, which can be exploited in a variety of ways.
k: total number of codes in the code space
n_s: number of symbols in the measurement interval
- 5) Calculate k RMS values, each RMS value unifying n_s symbols within one code.
(These values can be called "Absolute CodeEVMs" [Volt].)
- 6) Find the peak value among the k "Absolute CodeEVMs".
(This value can be called "Absolute PeakCodeEVM" [Volt].)
- 7) Calculate PCDE according to:

$$10 \cdot \lg \frac{(\text{"Absolute PeakCodeEVM"})^2}{(RMS(\mathbf{R}'))^2} \quad \text{dB} \quad (\text{a relative value in dB}).$$

(see Note2: Scrambling code)

(see Note IQ)

B.3 Notes

Note: Symbol length)

A general code multiplexed signal is multicode and multirate. In order to avoid unnecessary complexity, the measurement applications use a unique symbol-length, corresponding to a spreading factor, regardless of the really intended spreading factor. Nevertheless the complexity with a multicode / multirate signal can be mastered by introducing appropriate definitions.

Note: Deviation)

It is conceivable to regard more parameters as type „deviation" e.g. Chip frequency and RF-phase.

As chip-frequency and RF-frequency are linked together by a statement in the core specifications [1] it is sufficient to process RF frequency only.

A parameter RF-phase must be varied within the best fit process (B 2.6.). Although necessary, this parameter-variation doesn't describe any error, as the modulation schemes used in the system don't depend on an absolute RF-phase.

Note: Residual)

It is conceivable to regard more parameters as type „residual" e.g. IQ origin offset. As it is not the intention of the test to separate for different error sources, but to quantify the quality of the signal, all such parameters are not extracted by the best fit process, instead remain part of EVM and PCDE.

Note 1: Scrambling Code)

In general a TX signal under test can use more than one scrambling code. Note that PCDE is processed regarding the unused channelisation - codes as well. In order to know which scrambling code shall be applied on unused channelisation -codes, it is necessary to restrict the test conditions: TX signal under test shall use exactly one scrambling code.

Note 2: Scrambling Code)

To interpret the measurement results in practice it should be kept in mind that erroneous code power on unused codes is generally de-scrambled differently under test conditions and under real life conditions, whereas erroneous code power on used codes is generally de-scrambled equally under test conditions and under real life conditions. It might be indicated if a used or unused code hits PCDE.

Note IQ)

As in FDD/uplink each code can be used twice, on the I and on the Q channel, the measurement result may indicate separate values of CDP or PCDE for I and Q on which channel (I or Q) they occur.

Note: Fomula for the minimum process

$$L(\Delta \tilde{f}, \Delta \tilde{t}, \Delta \tilde{\varphi}, \Delta \tilde{g}_c, \dots) = \sum_{\nu=0}^{N-1} |Z(\nu) - R(\nu)|^2$$

Legend:

L : the function to be minimised

The parameters to be varied in order to minimize are:

$\Delta \tilde{f}$: the RF frequency offset

$\Delta \tilde{t}$: the timing offset

$\Delta \tilde{\varphi}$: the phase offset

$\Delta \tilde{g}_c \dots$ code power offsets (one offset for each code)

Z(v): Samples of the signal under Test

R(v): Samples of the reference signal

$\sum_{\nu=0}^{N-1}$: counting index ν starting at the beginning of the measurement interval and ending at its end.

N = No of chips during the measurement interval.

Z(v): Samples of the signal under Test. It is modelled as a sequence of complex baseband samples Z(γ) with a time-shift Δt, a frequency offset Δf, a phase offset Δφ, the latter three with respect to the reference signal.

$$Z(v) = Z(v - \Delta \tilde{t}) * e^{-j2\pi\Delta f v} * e^{-j\Delta \tilde{\varphi}}$$

R(v): Samples of the reference signal:

$$R(v) = \sum_{c=1}^{\text{No. of codes}} (g_c + \Delta \tilde{g}_c) * \text{Chip}_c(v)$$

g : nominal gain of the code channel

Δg̃ : The gain offset to be varied in the minimum process

Chip(v) is the chipsequence of the code channel

Indices at g, Δg and Chip:

The index indicates the code channel: c = 1,2,... No of code channels

Range for Chip_c : +1,-1

Note: **Formula for EVM**

$$EVM = \sqrt{\frac{\sum_{v=0}^{N-1} |Z'(\gamma) - R'(\gamma)|^2}{\sum_{v=0}^{N-1} |R'(\gamma)|^2}} * 100 \%$$

Z'(γ), R'(γ) are the varied measured and reference signals.

Annex C (normative): Measurement channels

C.1 General

The measurement channels in this annex are defined to derive the requirements in clauses 5, 6 and 7. The measurement channels represent example configuration of radio access bearers for different data rates.

The measurement channel for 12,2 kbps shall be supported by any UE both in up- and downlink. Support for other measurement channels is depending on the UE Radio Access capabilities.

C.2 UL reference measurement channel

C.2.1 UL reference measurement channel (12,2 kbps)

The parameters for the 12,2 kbps UL reference measurement channel are specified in table C.2.1.1, table C 2.1.2, table C 2.1.3 and table C.2.1.4. The channel coding for information is shown in figure C.2.1.

Table C.2.1.1: UL reference measurement channel physical parameters (12,2 kbps)

Parameter	Level	Unit
Information bit rate	12,2	kbps
DPDCH	60	kbps
DPCCH	15	kbps
DPCCH Slot Format #i	0	-
DPCCH/DPDCH power ratio	-5,46	dB
TFCI	On	-
Repetition	23	%
NOTE: Slot Format #2 is used for closed loop tests in clause 7.6.2. Slot Format #2 and #5 are used for site selection diversity transmission tests in subclause 7.6.3.		

Table C.2.1.2: UL reference measurement channel using RLC-TM for DTCH, transport channel parameters (12.2 kbps)

Higher Layer	RAB/Signalling RB	RAB	SRB	
RLC	Logical channel type	DTCH	DCCH	
	RLC mode	TM	UM/AM	
	Payload sizes, bit	244	88/80	
	Max data rate, bps	12200	2200/2000	
	PDU header, bit	N/A	8/16	
	TrD PDU header, bit	0	N/A	
MAC	MAC header, bit	0	4	
	MAC multiplexing	N/A	Yes	
Layer 1	TrCH type	DCH	DCH	
	Transport Channel Identity	1	5	
	TB sizes, bit	244	100	
	TFS	TF0, bits	0*244	0*100
		TF1, bits	1*244	1*100
	TTI, ms	20	40	
	Coding type	Convolution Coding	Convolution Coding	
	Coding Rate	1/3	1/3	
	CRC, bit	16	12	
	Max number of bits/TTI after channel coding	804	360	
	Uplink: Max number of bits/radio frame before rate matching	402	90	
	RM attribute	256	256	

Table C.2.1.3: UL reference measurement channel, TFCS (12.2 kbps)

TFCS size	4
TFCS	(DTCH, DCCH)= (TF0, TF0), (TF1, TF0), (TF0, TF1), (TF1, TF1)

NOTE: The TFCs except for (TF1, TF1) are belonging to minimum set of TFCs.

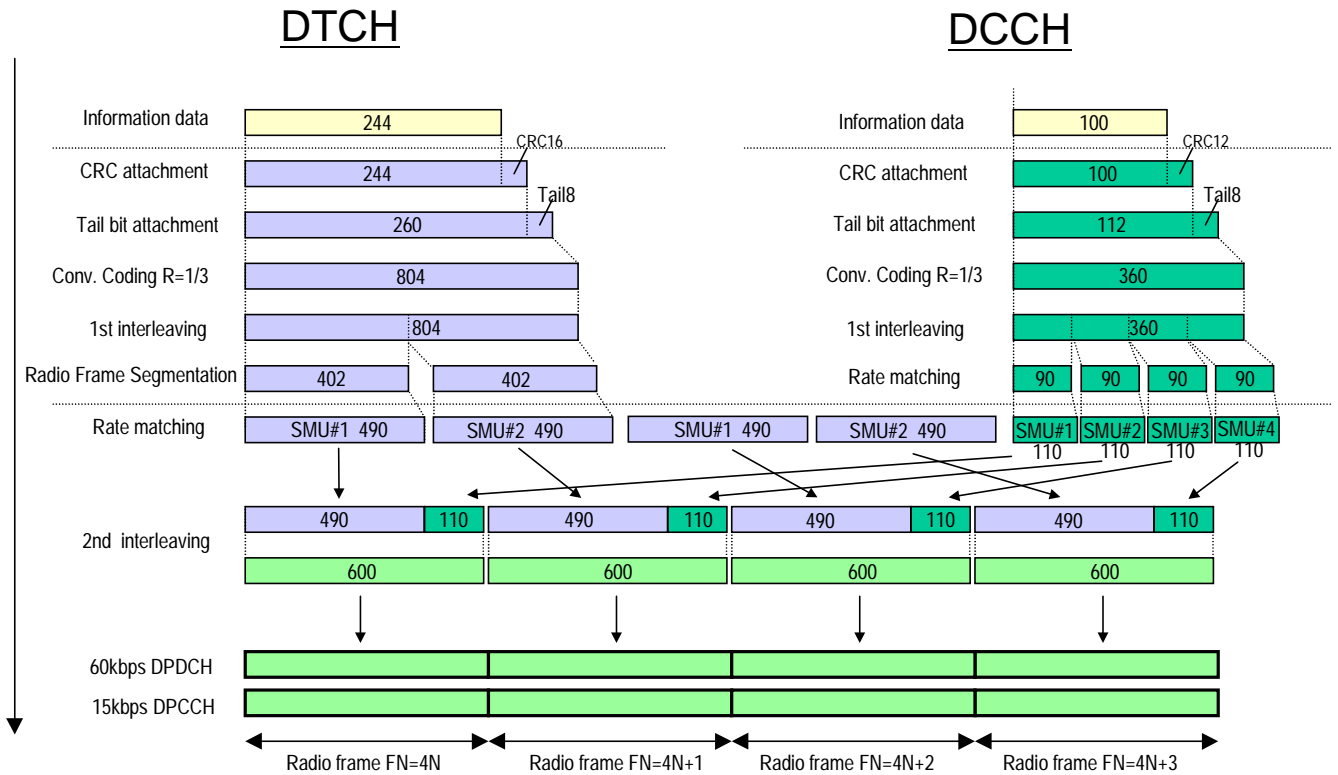

Figure C.2.1 (Informative): Channel coding of UL reference measurement channel (12,2 kbps)

C.2.2 UL reference measurement channel (64 kbps)

The parameters for the 64 kbps UL reference measurement channel are specified in table C.2.2.1, table C.2.2.2, table C.2.2.3 and table C.2.2.4. The channel coding for information is shown in figure C.2.2.

Table C.2.2.1: UL reference measurement channel (64 kbps)

Parameter	Level	Unit
Information bit rate	64	kbps
DPDCH	240	kbps
DPCCH	15	kbps
DPCCH Slot Format #i	0	-
DPCCH/DPDCH	-9,54	dB
TFCI	On	-
Repetition	18	%

Table C.2.2.2: UL reference measurement channel using RLC-TM for DTCH, transport channel parameters (64 kbps)

Higher Layer	RAB/Signalling RB	RAB	SRB	
RLC	Logical channel type	DTCH	DCCH	
	RLC mode	TM	UM/AM	
	Payload sizes, bit	1280	88/80	
	Max data rate, bps	64000	2200/2000	
	PDU header, bit	N/A	8/16	
	TrD PDU header, bit	0	N/A	
MAC	MAC header, bit	0	4	
	MAC multiplexing	N/A	Yes	
Layer 1	TrCH type	DCH	DCH	
	Transport Channel Identity	1	5	
	TB sizes, bit	1280	100	
	TFS	TF0, bits	0*1280	0*100
		TF1, bits	1*1280	1*100
	TTI, ms	20	40	
	Coding type	Turbo Coding	Convolution Coding	
	Coding Rate	N/A	1/3	
	CRC, bit	16	12	
	Max number of bits/TTI after channel coding	3900	360	
	Uplink: Max number of bits/radio frame before rate matching	1950	90	
	RM attribute	256	256	

Table C.2.2.3: UL reference measurement channel using RLC-AM for DTCH, transport channel parameters (64 kbps)

Higher Layer	RAB/Signalling RB	RAB	SRB	
RLC	Logical channel type	DTCH	DCCH	
	RLC mode	AM	UM/AM	
	Payload sizes, bit	1264	88/80	
	Max data rate, bps	63200	2200/2000	
	PDU header, bit	16	8/16	
	TrD PDU header, bit	N/A	N/A	
MAC	MAC header, bit	0	4	
	MAC multiplexing	N/A	Yes	
Layer 1	TrCH type	DCH	DCH	
	Transport Channel Identity	1	5	
	TB sizes, bit	1280	100	
	TFS	TF0, bits	0*1280	0*100
		TF1, bits	1*1280	1*100
	TTI, ms	20	40	
	Coding type	Turbo Coding	Convolution Coding	
	Coding Rate	N/A	1/3	
	CRC, bit	16	12	
	Max number of bits/TTI after channel coding	3900	360	
	Uplink: Max number of bits/radio frame before rate matching	1950	90	
	RM attribute	256	256	

Table C.2.2.4: UL reference measurement channel, TFCS (64 kbps)

TFCS size	4
TFCS	(DTCH, DCCH)= (TF0, TF0), (TF1, TF0), (TF0, TF1), (TF1, TF1)

NOTE: The TFCs except for (TF1, TF1) are belonging to minimum set of TFCs.

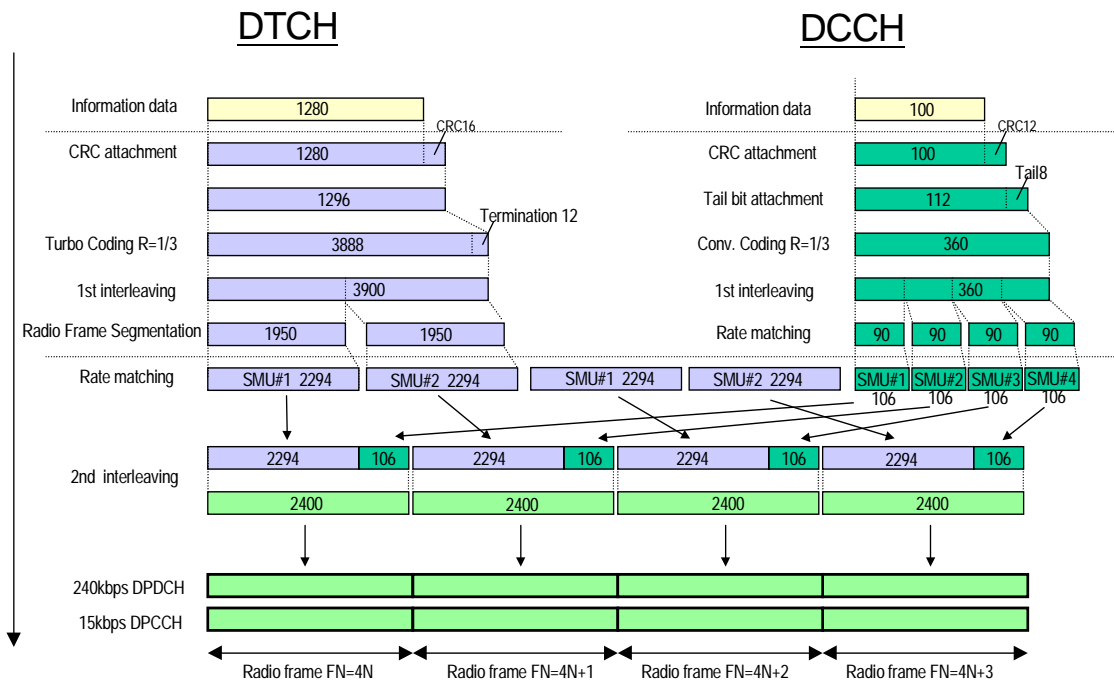

Figure C.2.2 (Informative): Channel coding of UL reference measurement channel (64 kbps)

C.2.3 UL reference measurement channel (144 kbps)

The parameters for the 144 kbps UL reference measurement channel are specified in table C.2.3.1, table C.2.3.2, table C.2.3.3 and table C.2.3.4. The channel coding for information is shown in figure C.2.3.

Table C.2.3.1: UL reference measurement channel (144 kbps)

Parameter	Level	Unit
Information bit rate	144	kbps
DPDCH	480	kbps
DPCCH	15	kbps
DPCCH Slot Format #i	0	-
DPCCH/DPDCH power ratio	-11,48	dB
TFCI	On	-
Repetition	8	%

Table C.2.3.2: UL reference measurement channel using RLC-TM for DTCH, transport channel parameters (144 kbps)

Higher Layer	RAB/Signalling RB	RAB	SRB	
RLC	Logical channel type	DTCH	DCCH	
	RLC mode	TM	UM/AM	
	Payload sizes, bit	2880	88/80	
	Max data rate, bps	144000	2200/2000	
	PDU header, bit	N/A	8/16	
	TrD PDU header, bit	0	N/A	
MAC	MAC header, bit	0	4	
	MAC multiplexing	N/A	Yes	
Layer 1	TrCH type	DCH	DCH	
	Transport Channel Identity	1	5	
	TB sizes, bit	2880	100	
	TFS	TF0, bits	0*2880	0*100
		TF1, bits	1*2880	1*100
	TTI, ms	20	40	
	Coding type	Turbo Coding	Convolution Coding	
	Coding Rate	N/A	1/3	
	CRC, bit	16	12	
	Max number of bits/TTI after channel coding	8700	360	
	Uplink: Max number of bits/radio frame before rate matching	4350	90	
	RM attribute	256	256	

Table C.2.3.3: UL reference measurement channel using RLC-AM for DTCH, transport channel parameters (144 kbps)

Higher Layer	RAB/Signalling RB	RAB	SRB	
RLC	Logical channel type	DTCH	DCCH	
	RLC mode	AM	UM/AM	
	Payload sizes, bit	2864	88/80	
	Max data rate, bps	143200	2200/2000	
	PDU header, bit	16	8/16	
	TrD PDU header, bit	N/A	N/A	
MAC	MAC header, bit	0	4	
	MAC multiplexing	N/A	Yes	
Layer 1	TrCH type	DCH	DCH	
	Transport Channel Identity	1	5	
	TB sizes, bit	2880	100	
	TFS	TF0, bits	0*2880	0*100
		TF1, bits	1*2880	1*100
	TTI, ms	20	40	
	Coding type	Turbo Coding	Convolution Coding	
	Coding Rate	N/A	1/3	
	CRC, bit	16	12	
	Max number of bits/TTI after channel coding	8700	360	
	Uplink: Max number of bits/radio frame before rate matching	4350	90	
	RM attribute	256	256	

Table C.2.3.4: UL reference measurement channel, TFCS (144 kbps)

TFCS size	4
TFCS	(DTCH, DCCH)= (TF0, TF0), (TF1, TF0), (TF0, TF1), (TF1, TF1)

NOTE: The TFCs except for (TF1, TF1) are belonging to minimum set of TFCs.

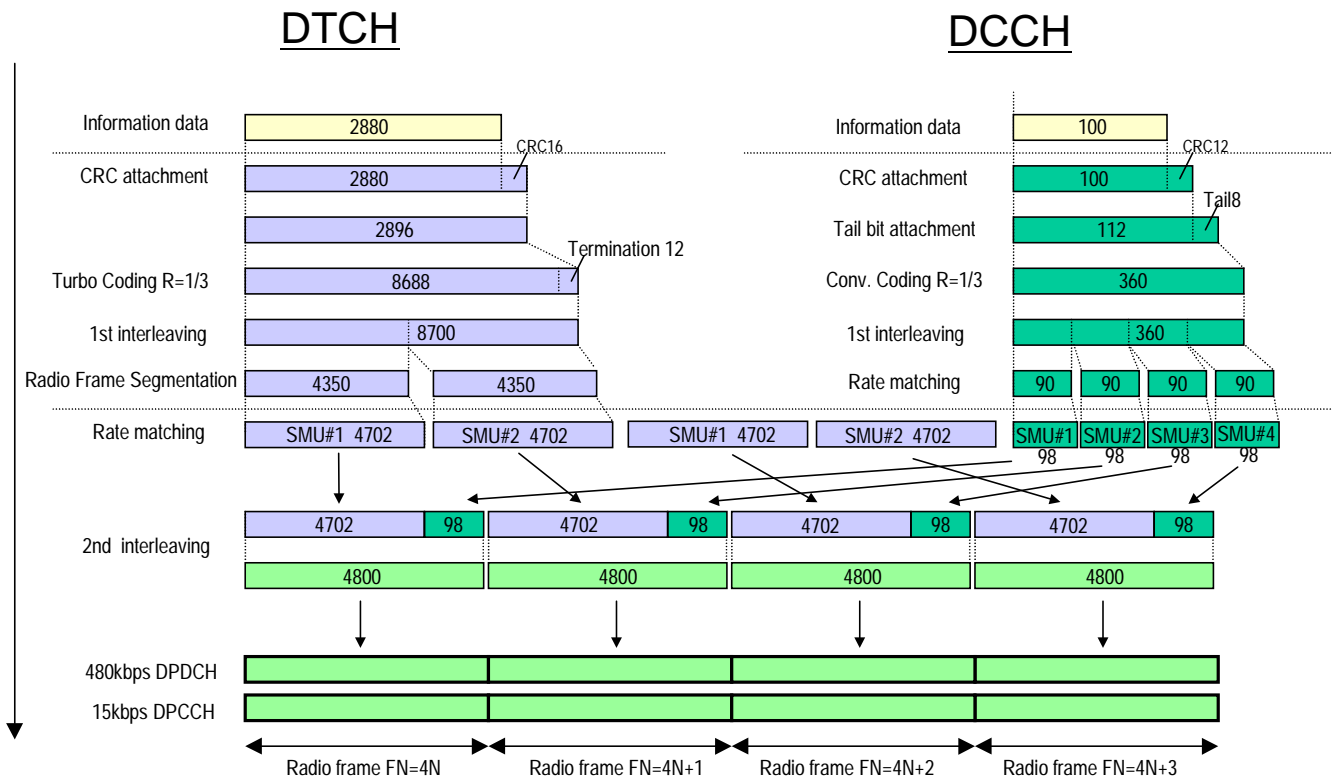

Figure C.2.3 (Informative): Channel coding of UL reference measurement channel (144 kbps)

C.2.4 UL reference measurement channel (384 kbps)

The parameters for the 384 kbps UL reference measurement channel are specified in table C.2.4.1, table C.2.4.2, table C.2.4.3 and table C.2.4.4. The channel coding for information is shown in figure C.2.4.

Table C.2.4.1: UL reference measurement channel (384 kbps)

Parameter	Level	Unit
Information bit rate	384	kbps
DPDCH	960	kbps
DPCCH	15	kbps
DPCCH Slot Format #i	0	-
DPCCH/DPDCH power ratio	-11,48	dB
TFCI	On	-
Puncturing	18	%

Table C.2.4.2: UL reference measurement channel using RLC-TM for DTCH, transport channel parameters (384 kbps)

Higher Layer	RAB/Signalling RB	RAB	SRB	
RLC	Logical channel type	DTCH	DCCH	
	RLC mode	TM	UM/AM	
	Payload sizes, bit	3840	88/80	
	Max data rate, bps	384000	2200/2000	
	PDU header, bit	N/A	8/16	
	TrD PDU header, bit	0	N/A	
MAC	MAC header, bit	0	4	
	MAC multiplexing	N/A	Yes	
Layer 1	TrCH type	DCH	DCH	
	Transport Channel Identity	1	5	
	TB sizes, bit	3840	100	
	TFS	TF0, bits	0*3840	0*100
		TF1, bits	1*3840	1*100
	TTI, ms	10	40	
	Coding type	Turbo Coding	Convolution Coding	
	Coding Rate	N/A	1/3	
	CRC, bit	16	12	
	Max number of bits/TTI after channel coding	11580	360	
	Uplink: Max number of bits/radio frame before rate matching	11580	90	
	RM attribute	256	256	

Table C.2.4.3: UL reference measurement channel using RLC-AM for DTCH, transport channel parameters (384 kbps)

Higher Layer	RAB/Signalling RB	RAB	SRB	
RLC	Logical channel type	DTCH	DCCH	
	RLC mode	AM	UM/AM	
	Payload sizes, bit	3824	88/80	
	Max data rate, bps	382400	2200/2000	
	PDU header, bit	16	8/16	
	TrD PDU header, bit	N/A	N/A	
MAC	MAC header, bit	0	4	
	MAC multiplexing	N/A	Yes	
Layer 1	TrCH type	DCH	DCH	
	Transport Channel Identity	1	5	
	TB sizes, bit	3840	100	
	TFS	TF0, bits	0*3840	0*100
		TF1, bits	1*3840	1*100
	TTI, ms	10	40	
	Coding type	Turbo Coding	Convolution Coding	
	Coding Rate	N/A	1/3	
	CRC, bit	16	12	
	Max number of bits/TTI after channel coding	11580	360	
	Uplink: Max number of bits/radio frame before rate matching	11580	90	
	RM attribute	256	256	

Table C.2.4.4: UL reference measurement channel, TFCS (384 kbps)

TFCS size	4
TFCS	(DTCH, DCCH)= (TF0, TF0), (TF1, TF0), (TF0, TF1), (TF1, TF1)

NOTE: The TFCs except for (TF1, TF1) are belonging to minimum set of TFCs.

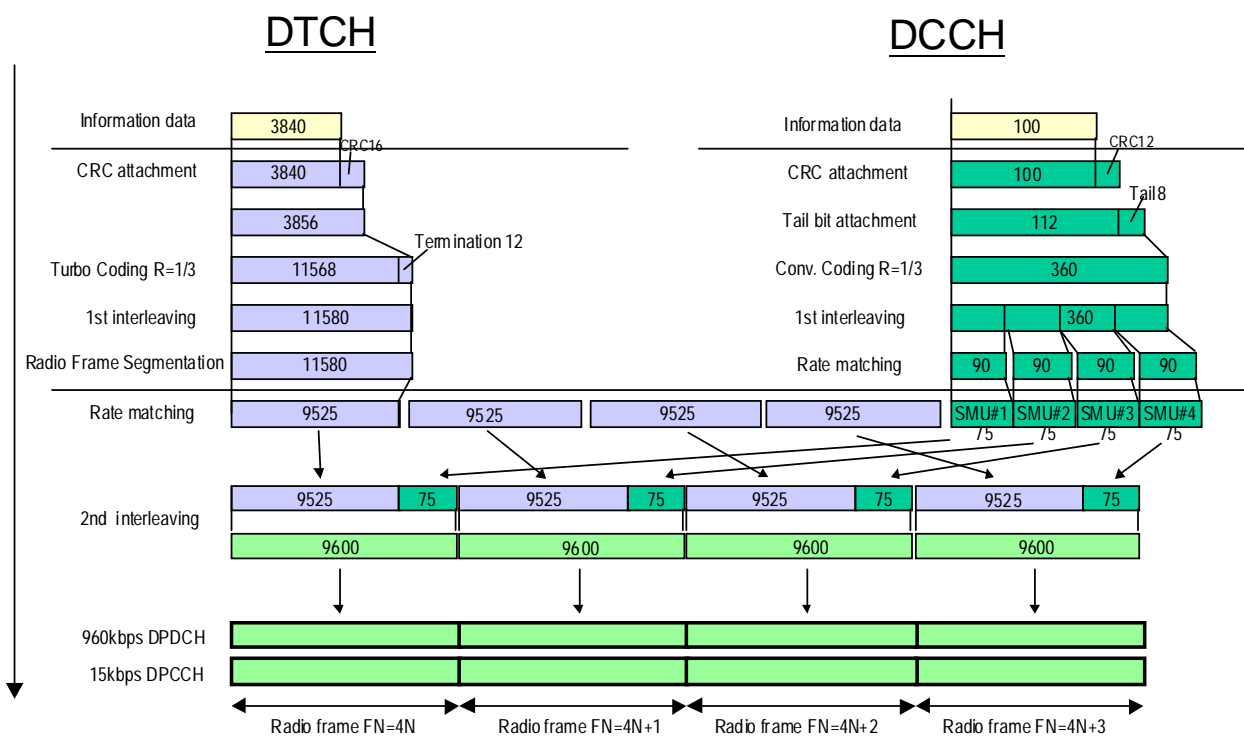

Figure C.2.4 (informative): Channel coding of UL reference measurement channel (384 kbps)

C.2.5 UL reference measurement channel (768 kbps)

The parameters for the UL measurement channel for 768 kbps are specified in table C.2.5.1, table C.2.5.2, table C.2.5.3 and table C.2.5.4.

Table C.2.5.1: UL reference measurement channel, physical parameters (768 kbps)

Parameter	Level	Unit
Information bit rate	2*384	kbps
DPDCH ₁	960	kbps
DPDCH ₂	960	kbps
DPCCH	15	kbps
DPCCH Slot Format #i	0	-
DPCCH/DPDCH power ratio	-11.48	dB
TFCI	On	-
Puncturing	18	%

Table C.2.5.2: UL reference measurement channel using RLC-TM for DTCH, transport channel parameters (768 kbps)

Higher Layer	RAB/Signalling RB	RAB	SRB	
RLC	Logical channel type	DTCH	DCCH	
	RLC mode	TM	UM/AM	
	Payload sizes, bit	7680	88/80	
	Max data rate, bps	768000	2200/2000	
	PDU header, bit	N/A	8/16	
	TrD PDU header, bit	0	N/A	
MAC	MAC header, bit	0	4	
	MAC multiplexing	N/A	Yes	
Layer 1	TrCH type	DCH	DCH	
	Transport Channel Identity	1	5	
	TB sizes, bit	3840	100	
	TFS	TF0, bits	0*3840	0*100
		TF1, bits	2*3840	1*100
	TTI, ms	10	40	
	Coding type	Turbo Coding	Convolution Coding	
	Coding Rate	N/A	1/3	
	CRC, bit	16	12	
	Max number of bits/TTI after channel coding	23160	360	
	Uplink: Max number of bits/radio frame before rate matching	23160	90	
	RM attribute	256	256	

Table C.2.5.3: UL reference measurement channel using RLC-AM for DTCH, transport channel parameters (768 kbps)

Higher Layer	RAB/Signalling RB	RAB	SRB	
RLC	Logical channel type	DTCH	DCCH	
	RLC mode	TM	UM/AM	
	Payload sizes, bit	7664	88/80	
	Max data rate, bps	766400	2200/2000	
	PDU header, bit	16	8/16	
	TrD PDU header, bit	N/A	N/A	
MAC	MAC header, bit	0	4	
	MAC multiplexing	N/A	Yes	
Layer 1	TrCH type	DCH	DCH	
	Transport Channel Identity	1	5	
	TB sizes, bit	3840	100	
	TFS	TF0, bits	0*3840	0*100
		TF1, bits	2*3840	1*100
	TTI, ms	10	40	
	Coding type	Turbo Coding	Convolution Coding	
	Coding Rate	N/A	1/3	
	CRC, bit	16	12	
	Max number of bits/TTI after channel coding	23160	360	
	Uplink: Max number of bits/radio frame before rate matching	23160	90	
	RM attribute	256	256	

Table C.2.5.4: UL reference measurement channel, TFCS (768 kbps)

TFCS size	4
TFCS	(DTCH, DCCH)= (TF0, TF0), (TF1, TF0), (TF0, TF1), (TF1, TF1)

NOTE: The TFCs except for (TF1, TF1) are belonging to minimum set of TFCs.

C.3 DL reference measurement channel

C.3.1 DL reference measurement channel (12.2 kbps)

The parameters for the 12,2 kbps DL reference measurement channel are specified in table C.3.1.1, table C.3.1.2 and table C.3.1.3. The channel coding is detailed in figure C.3.1. For the RLC configuration of AM DCCHs Timer_STATUS_Periodic shall not be set in RRC CONNECTION SETUP message used in test procedure for RF test as defined in TS 34.108 [3] clause 7.3. This is to prevent unexpected DCHs from being transmitted through such RLC entities when the timer has expired in order to sure that the required TFC from the minimum set of TFCs can continuously convey a DCH for DTCH during the test.

Table C.3.1.1: DL reference measurement channel (12.2 kbps)

Parameter	Level	Unit
Information bit rate	12.2	kbps
DPCH	30	ksps
Slot Format #l	11	-
TFCI	On	
Power offsets PO1, PO2 and PO3	0	dB
DTX position	Fixed	-

Table C.3.1.2: DL reference measurement channel using RLC-TM for DTCH, transport channel parameters (12.2 kbps)

Higher Layer	RAB/Signalling RB	RAB	SRB	
RLC	Logical channel type	DTCH	DCCH	
	RLC mode	TM	UM/AM	
	Payload sizes, bit	244	88/80	
	Max data rate, bps	12200	2200/2000	
	PDU header, bit	N/A	8/16	
	TrD PDU header, bit	0	N/A	
MAC	MAC header, bit	0	4	
	MAC multiplexing	N/A	Yes	
Layer 1	TrCH type	DCH	DCH	
	Transport Channel Identity	6	10	
	TB sizes, bit	244	100	
	TFS	TF0, bits	0*244	0*100
		TF1, bits	1*244	1*100
	TTI, ms	20	40	
	Coding type	Convolution Coding	Convolution Coding	
	Coding Rate	1/3	1/3	
	CRC, bit	16	12	
	Max number of bits/TTI after channel coding	804	360	
	RM attribute	256	256	

Table C.3.1.3: DL reference measurement channel, TFCS (12.2 kbps)

TFCS size	4
TFCS	(DTCH, DCCH)= (TF0, TF0), (TF1, TF0), (TF0, TF1), (TF1, TF1)

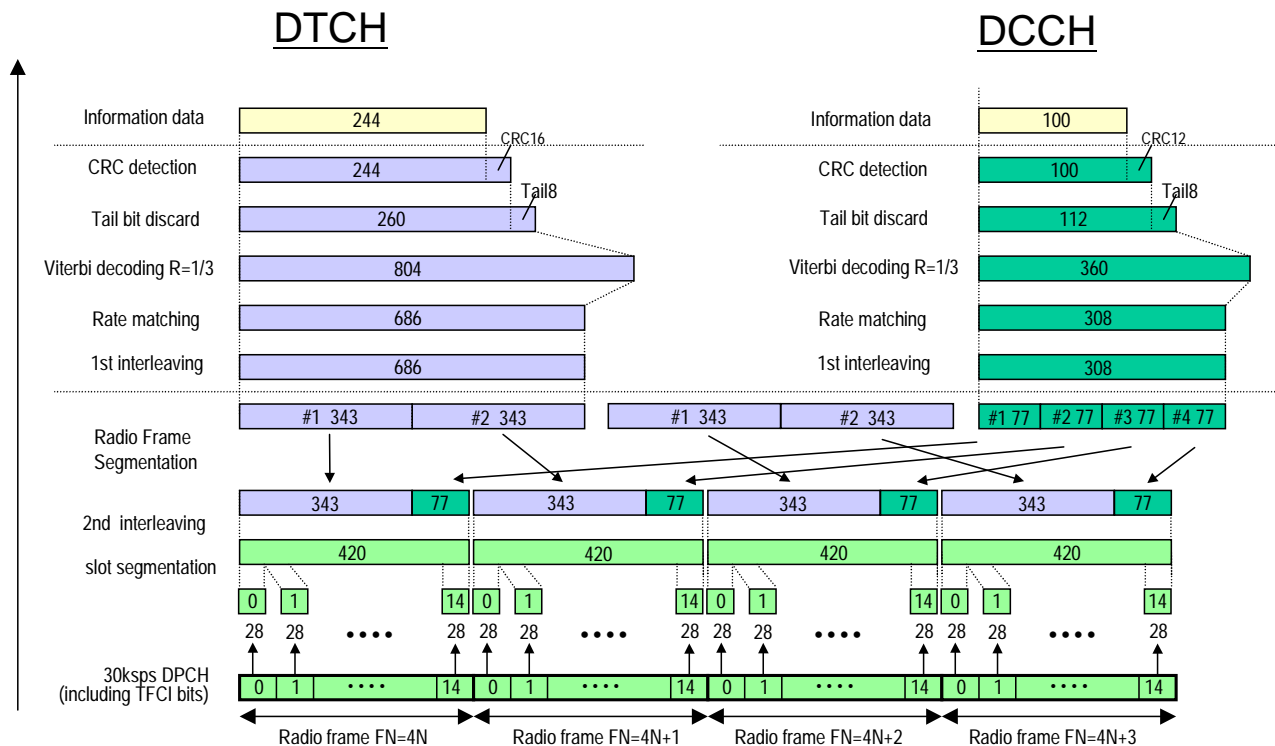

Figure C.3.1 (informative): Channel coding of DL reference measurement channel (12.2 kbps)

C.3.1A DL reference measurement channel (0 kbps and 12.2 kbps)

The parameters for the 0 kbps and 12.2 kbps DL reference measurement channel are specified in table C.3.1A.1, table C.3.1A.2 and table C.3.1A.3. The channel coding is detailed in figures C.3.1A and C.3.1B. For the RLC configuration of AM DCCHs Timer_STATUS_Periodic shall not be set in RRC CONNECTION SETUP message used in the test procedure for RF testing as defined in TS 34.108 [3] clause 7.3. This is to prevent unexpected DCHs from being transmitted through such RLC entities when the timer has expired in order to make sure that the required TFC from the minimum set of TFCs can continuously convey a DCH for DTCH during the test.

Table C.3.1A.1: DL reference measurement channel (0 kbps and 12.2 kbps)

Parameter	Level	Unit
Information bit rate	12.2	kbps
DPCH	30	ksp
Slot Format #1	11	-
TFCS	On	-
Power offsets PO1, PO2 and PO3	0	dB
DTX position	Fixed	-

Table C.3.1A.2: DL reference measurement channel using RLC-TM for DTCH, transport channel parameters (0 kbps and 12.2 kbps)

Higher Layer	RAB/Signalling RB	RAB	SRB	
RLC	Logical channel type	DTCH	DCCH	
	RLC mode	TM	UM/AM	
	Payload sizes, bit	244	88/80	
	Max data rate, bps	12200	2200/2000	
	PDU header, bit	N/A	8/16	
	TrD PDU header, bit	0	N/A	
MAC	MAC header, bit	0	4	
	MAC multiplexing	N/A	Yes	
Layer 1	TrCH type	DCH	DCH	
	Transport Channel Identity	6	10	
	TB sizes, bit	244	100	
	TFS	TF0, bits	1*0	0*100
		TF1, bits	1*244	1*100
	TTI, ms	20	40	
	Coding type	Convolution Coding	Convolution Coding	
	Coding Rate	1/3	1/3	
	CRC, bit	16	12	
	Max number of bits/TTI after channel coding	804	360	
	RM attribute	256	256	

Table C.3.1A.3: DL reference measurement channel, TFCS (0 kbps and 12.2 kbps)

TFCS size	4
TFCS	(DTCH, DCCH)= (TF0, TF0), (TF1, TF0), (TF0, TF1), (TF1, TF1)

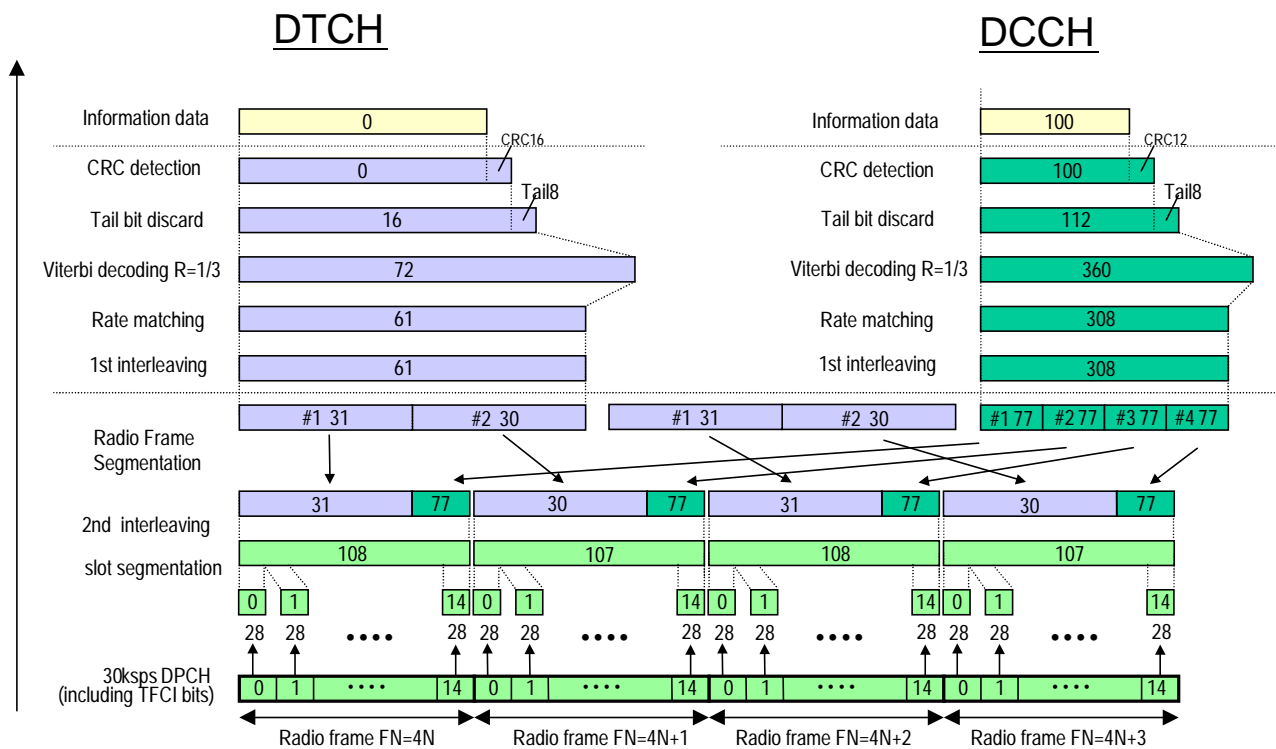

Figure C.3.1A (Informative): Channel coding of DL reference measurement channel (0 kbps)

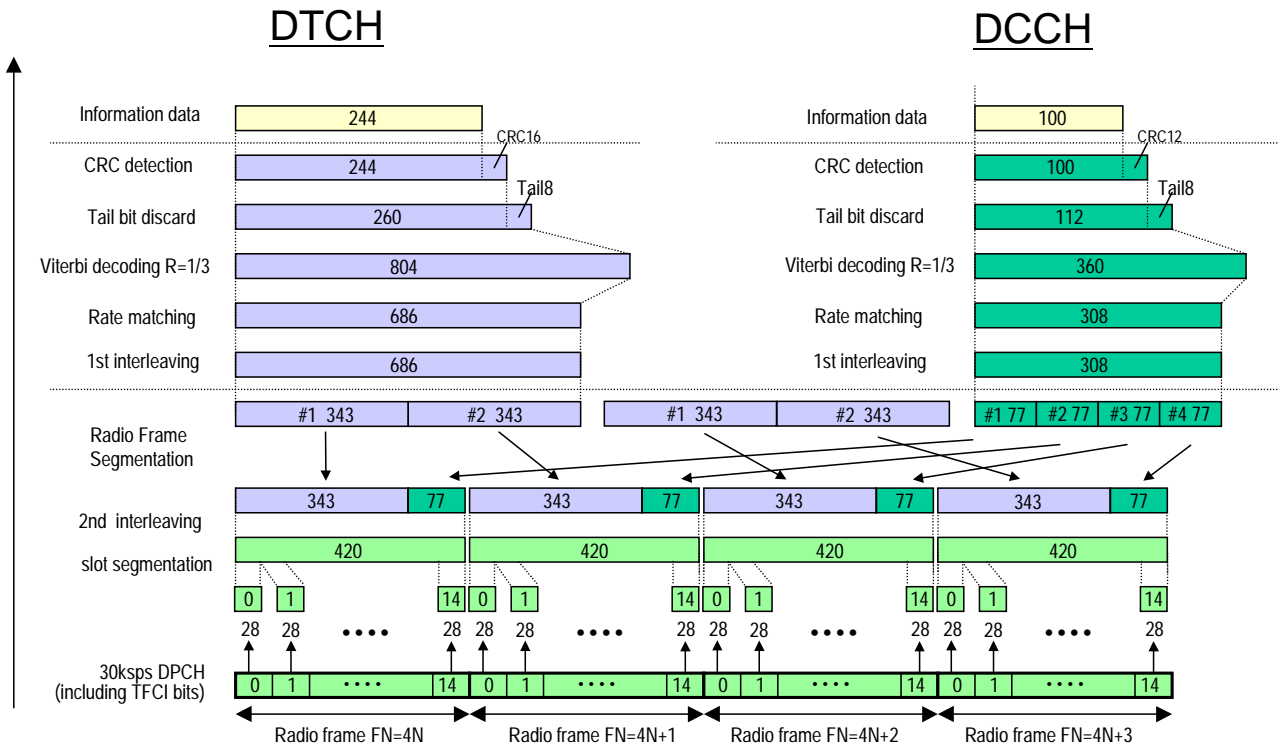

Figure C.3.1B (informative): Channel coding of DL reference measurement channel (12.2 kbps)

C.3.2 DL reference measurement channel (64 kbps)

The parameters for the DL reference measurement channel for 64 kbps are specified in table C.3.2.1, table C.3.2.2, table C.3.2.3 and table C.3.2.4. The channel coding is detailed in figure C.3.2. For the RLC configuration of AM DCCHs Timer_STATUS_Periodic shall not be set in RRC CONNECTION SETUP message used in test procedure for RF test as defined in TS 34.108 [3] clause 7.3. This is to prevent unexpected DCHs from being transmitted through such RLC entities when the timer has expired in order to sure that the required TFC from the minimum set of TFCs can continuously convey a DCH for DTCH during the test.

Table C.3.2.1: DL reference measurement channel (64 kbps)

Parameter	Level	Unit
Information bit rate	64	kbps
DPCH	120	ksps
Slot Format #i	13	-
TFCI	On	-
Power offsets PO1, PO2 and PO3	0	dB
DTX position	Fixed	-

Table C.3.2.2: DL reference measurement channel using RLC-TM for DTCH, transport channel parameters (64 kbps)

Higher Layer	RAB/Signalling RB	RAB	SRB	
RLC	Logical channel type	DTCH	DCCH	
	RLC mode	TM	UM/AM	
	Payload sizes, bit	1280	88/80	
	Max data rate, bps	64000	2200/2000	
	PDU header, bit	N/A	8/16	
	TrD PDU header, bit	0	N/A	
MAC	MAC header, bit	0	4	
	MAC multiplexing	N/A	Yes	
Layer 1	TrCH type	DCH	DCH	
	Transport Channel Identity	6	10	
	TB sizes, bit	1280	100	
	TFS	TF0, bits	0*1280	0*100
		TF1, bits	1*1280	1*100
	TTI, ms	20	40	
	Coding type	Turbo Coding	Convolution Coding	
	Coding Rate	N/A	1/3	
	CRC, bit	16	12	
	Max number of bits/TTI after channel coding	3900	360	
	RM attribute	256	256	

Table C.3.2.3: DL reference measurement channel using RLC-AM for DTCH, transport channel parameters (64 kbps)

Higher Layer	RAB/Signalling RB	RAB	SRB	
RLC	Logical channel type	DTCH	DCCH	
	RLC mode	AM	UM/AM	
	Payload sizes, bit	1264	88/80	
	Max data rate, bps	63200	2200/2000	
	PDU header, bit	16	8/16	
	TrD PDU header, bit	N/A	N/A	
MAC	MAC header, bit	0	4	
	MAC multiplexing	N/A	Yes	
Layer 1	TrCH type	DCH	DCH	
	Transport Channel Identity	6	10	
	TB sizes, bit	1280	100	
	TFS	TF0, bits	0*1280	0*100
		TF1, bits	1*1280	1*100
	TTI, ms	20	40	
	Coding type	Turbo Coding	Convolution Coding	
	Coding Rate	N/A	1/3	
	CRC, bit	16	12	
	Max number of bits/TTI after channel coding	3900	360	
	RM attribute	256	256	

Table C.3.2.4: DL reference measurement channel, TFCS (64 kbps)

TFCS size	4
TFCS	(DTCH, DCCH)= (TF0, TF0), (TF1, TF0), (TF0, TF1), (TF1, TF1)

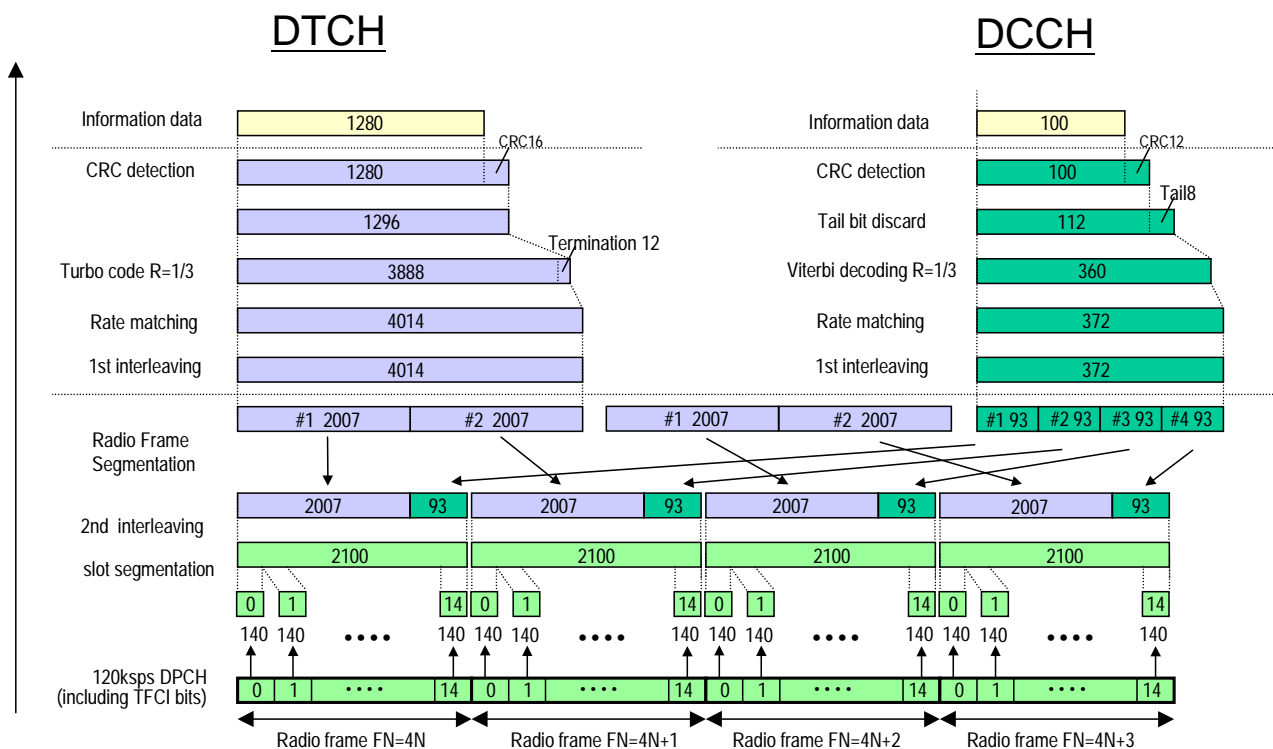

Figure C.3.2 (informative): Channel coding of DL reference measurement channel (64 kbps)

C.3.3 DL reference measurement channel (144 kbps)

The parameters for the DL reference measurement channel for 144 kbps are specified in table C.3.3.1, table C.3.3.2, table C.3.3.3 and table C.3.3.4. The channel coding is detailed in figure C.3.3. For the RLC configuration of AM DCCHs Timer_STATUS_Periodic shall not be set in RRC CONNECTION SETUP message used in test procedure for RF test as defined in TS 34.108 [3] clause 7.3. This is to prevent unexpected DCHs from being transmitted through such RLC entities when the timer has expired in order to sure that the required TFC from the minimum set of TFCs can continuously convey a DCH for DTCH during the test.

Table C.3.3.1: DL reference measurement channel (144kbps)

Parameter	Level	Unit
Information bit rate	144	kbps
DPCH	240	ksps
Slot Format #i	14	-
TFCI	On	-
Power offsets PO1, PO2 and PO3	0	dB
DTX position	Fixed	-

Table C.3.3.2: DL reference measurement channel using RLC-TM for DTCH, transport channel parameters (144 kbps)

Higher Layer	RAB/Signalling RB	RAB	SRB	
RLC	Logical channel type	DTCH	DCCH	
	RLC mode	TM	UM/AM	
	Payload sizes, bit	2880	88/80	
	Max data rate, bps	144000	2200/2000	
	PDU header, bit	N/A	8/16	
	TrD PDU header, bit	0	N/A	
MAC	MAC header, bit	0	4	
	MAC multiplexing	N/A	Yes	
Layer 1	TrCH type	DCH	DCH	
	Transport Channel Identity	6	10	
	TB sizes, bit	2880	100	
	TFS	TF0, bits	0*2880	0*100
		TF1, bits	1*2880	1*100
	TTI, ms	20	40	
	Coding type	Turbo Coding	Convolution Coding	
	Coding Rate	N/A	1/3	
	CRC, bit	16	12	
	Max number of bits/TTI after channel coding	8700	360	
	RM attribute	256	256	

Table C.3.3.3: DL reference measurement channel using RLC-AM for DTCH, transport channel parameters (144 kbps)

Higher Layer	RAB/Signalling RB	RAB	SRB	
RLC	Logical channel type	DTCH	DCCH	
	RLC mode	AM	UM/AM	
	Payload sizes, bit	2864	88/80	
	Max data rate, bps	143200	2200/2000	
	PDU header, bit	16	8/16	
	TrD PDU header, bit	N/A	N/A	
MAC	MAC header, bit	0	4	
	MAC multiplexing	N/A	Yes	
Layer 1	TrCH type	DCH	DCH	
	Transport Channel Identity	6	10	
	TB sizes, bit	2880	100	
	TFS	TF0, bits	0*2880	0*100
		TF1, bits	1*2880	1*100
	TTI, ms	20	40	
	Coding type	Turbo Coding	Convolution Coding	
	Coding Rate	N/A	1/3	
	CRC, bit	16	12	
	Max number of bits/TTI after channel coding	8700	360	
	RM attribute	256	256	

Table C.3.3.4: DL reference measurement channel, TFCS (144 kbps)

TFCS size	4
TFCS	(DTCH, DCCH)= (TF0, TF0), (TF1, TF0), (TF0, TF1), (TF1, TF1)

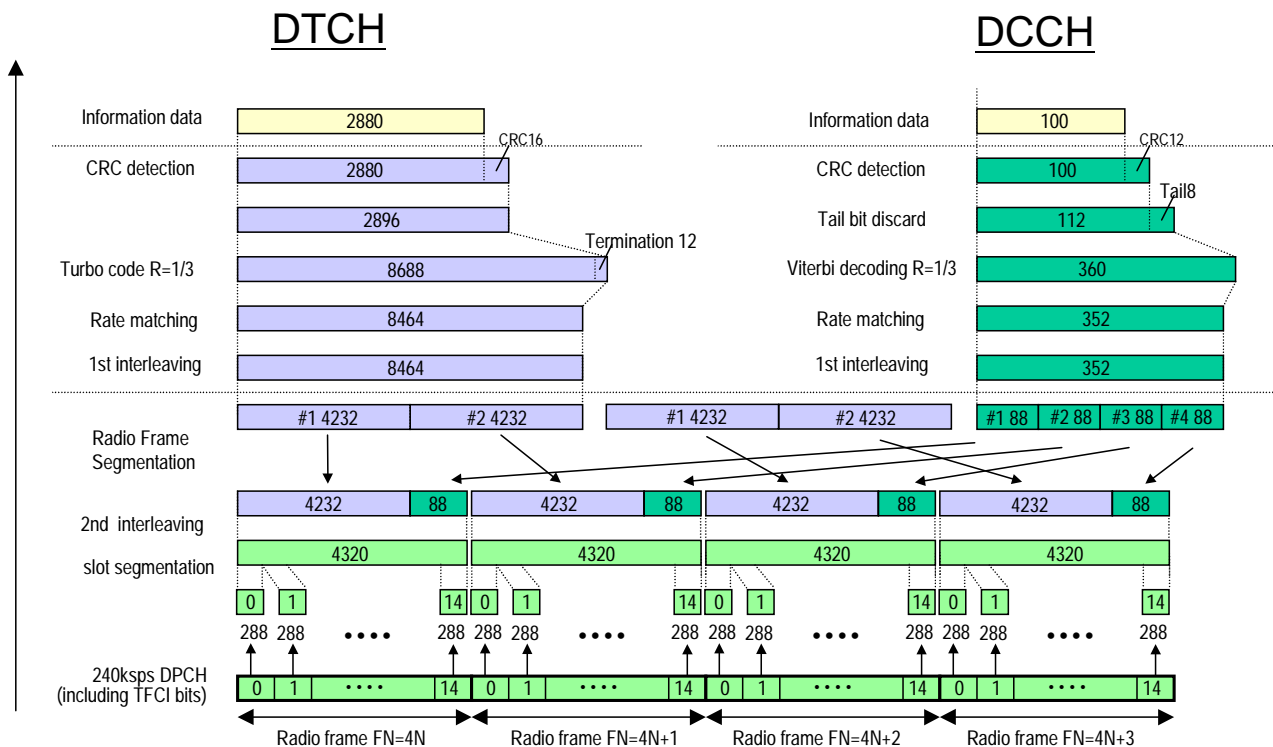

Figure C.3.3 (informative): Channel coding of DL reference measurement channel (144 kbps)

C.3.4 DL reference measurement channel (384 kbps)

The parameters for the DL reference measurement channel for 384 kbps are specified in table C.3.4.1, table C.3.4.2, table C.3.4.3 and table C.3.4.4. The channel coding is shown for information in figure C3.4. For the RLC configuration of AM DCCHs Timer_STATUS_Periodic shall not be set in RRC CONNECTION SETUP message used in test procedure for RF test as defined in TS 34.108 [3] clause 7.3. This is to prevent unexpected DCHs from being transmitted through such RLC entities when the timer has expired in order to sure that the required TFC from the minimum set of TFCs can continuously convey a DCH for DTCH during the test.

Table C.3.4.1: DL reference measurement channel, physical parameters (384 kbps)

Parameter	Level	Unit
Information bit rate	384	kbps
DPCH	480	ksps
Slot Format #i	15	-
TFCI	On	-
Power offsets PO1, PO2 and PO3	0	dB
DTX position	Fixed	-

Table C.3.4.2: DL reference measurement channel using RLC-TM for DTCH, transport channel parameters (384 kbps)

Higher Layer	RAB/Signalling RB	RAB	SRB	
RLC	Logical channel type	DTCH	DCCH	
	RLC mode	TM	UM/AM	
	Payload sizes, bit	3840	88/80	
	Max data rate, bps	384000	2200/2000	
	PDU header, bit	N/A	8/16	
	TrD PDU header, bit	0	N/A	
MAC	MAC header, bit	0	4	
	MAC multiplexing	N/A	Yes	
Layer 1	TrCH type	DCH	DCH	
	Transport Channel Identity	6	10	
	TB sizes, bit	3840	100	
	TFS	TF0, bits	0*3840	0*100
		TF1, bits	1*3840	1*100
	TTI, ms	10	40	
	Coding type	Turbo Coding	Convolution Coding	
	Coding Rate	N/A	1/3	
	CRC, bit	16	12	
	Max number of bits/TTI after channel coding	11580	360	
	RM attribute	256	256	

Table C.3.4.3: DL reference measurement channel using RLC-AM for DTCH, transport channel parameters (384 kbps)

Higher Layer	RAB/Signalling RB	RAB	SRB	
RLC	Logical channel type	DTCH	DCCH	
	RLC mode	AM	UM/AM	
	Payload sizes, bit	3824	88/80	
	Max data rate, bps	382400	2200/2000	
	PDU header, bit	16	8/16	
	TrD PDU header, bit	N/A	N/A	
MAC	MAC header, bit	0	4	
	MAC multiplexing	N/A	Yes	
Layer 1	TrCH type	DCH	DCH	
	Transport Channel Identity	6	10	
	TB sizes, bit	3840	100	
	TFS	TF0, bits	0*3840	0*100
		TF1, bits	1*3840	1*100
	TTI, ms	10	40	
	Coding type	Turbo Coding	Convolution Coding	
	Coding Rate	N/A	1/3	
	CRC, bit	16	12	
	Max number of bits/TTI after channel coding	11580	360	
	RM attribute	256	256	

Table C.3.4.4: DL reference measurement channel, TFCS (384 kbps)

TFCS size	4
TFCS	(DTCH, DCCH)= (TF0, TF0), (TF1, TF0), (TF0, TF1), (TF1, TF1)

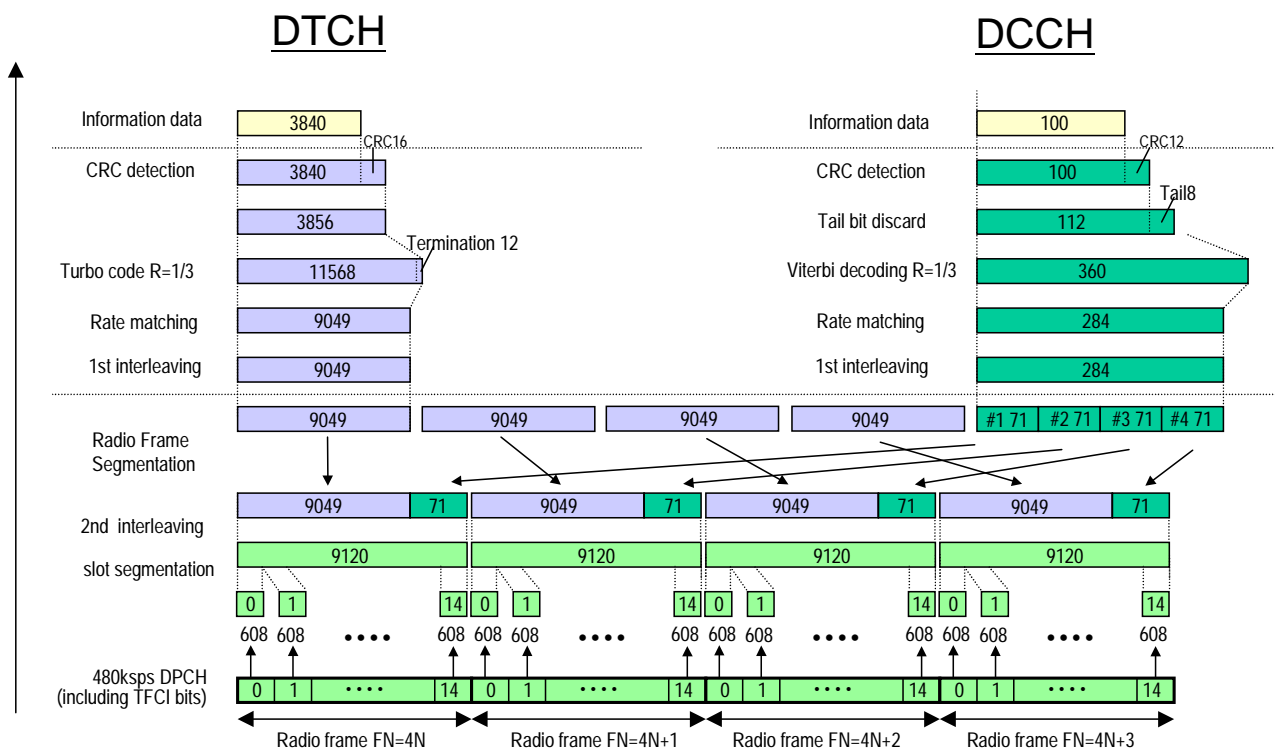

Figure C.3.4 (informative): Channel coding of DL reference measurement channel (384 kbps)

C.4 Reference measurement channel for BTFD performance requirements

C.4.1 UL reference measurement channel for BTFD performance requirements

The parameters for UL reference measurement channel for BTFD are specified in table C.4.1.1, table C.4.1.2, table C.4.1.3 and table C.4.1.4.

Table C.4.1.1: UL reference measurement channel physical parameters for BTFD

Parameter	Level	Unit
Information bit rate	12.8k, 10.8k, 8.55k, 8.0k, 7.3k, 6.5k, 5.75k, 5.35k, 2.55k	kbps
DPCCH	15	kbps
DPCCH Slot Format #i	0	-
DPCCH/DPDCH power ratio	-5.46 (12.8k - 7.3k)	dB
	-2.69 (6.5k - 2.55k)	
TFCI	On	-
Puncturing Limit	100	%

Table C.4.1.2: UL reference measurement channel, transport channel parameters for SRB

Higher Layer	RAB/Signalling RB	SRB	
RLC	Logical channel type	DCCH	
	RLC mode	UM/AM	
	Payload sizes, bit	88/80	
	Max data rate, bps	2200/2000	
	PDU header, bit	8/16	
	TrD PDU header, bit	N/A	
MAC	MAC header, bit	4	
	MAC multiplexing	Yes	
Layer 1	TrCH type	DCH	
	Transport Channel Identity	10	
	TB sizes, bit	100	
	TFS	TF0, bits	0*100
		TF1, bits	1*100
	TTI, ms	40	
	Coding type	Convolution Coding	
	Coding Rate	1/3	
	CRC, bit	12	
	Max number of bits/TTI after channel coding	360	
	Uplink: Max number of bits/radio frame before rate matching	90	
	RM attribute	256	

Table C.4.1.3: UL reference measurement channel using RLC-TM for DTCH, transport channel parameters

Higher Layer	RAB/Signalling RB	12.8k /10.8k/8.55k/8.0k/7.3k/6.5k/5.75k/5.35k/2.55k	
RLC	Logical channel type	DTCH	
	RLC mode	TM	
	Payload sizes, bit	256, 216, 171, 160, 146, 130, 115, 107, 51, 12	
	Max data rate, bps	12200	
	PDU header, bit	N/A	
	TrD PDU header, bit	0	
MAC	MAC header, bit	0	
	MAC multiplexing	N/A	
Layer 1	TrCH type	DCH	
	Transport Channel Identity	1	
	TB sizes, bit	256, 216, 171, 160, 146, 130, 115, 107, 51,12	
	TFS	TF0 bit	0x256
		TF1 bit	1x256
		TF2 bit	1x216
		TF3 bit	1x171
		TF4 bit	1x160
		TF5 bit	1x146
		TF6 bit	1x130
		TF7 bit	1x115
		TF8 bit	1x107
		TF9 bit	1x51
	TF10 bit	1x12	
	TTI, ms	20	
	Coding type	CC	
Coding Rate	1/3		
CRC, bit	0		
RM attribute	256		

Table C.4.1.4: UL reference measurement channel, TFCS

TFCS size	22
TFCS	(DTCH, DCCH)= (TF0, TF0), (TF1, TF0), (TF2, TF0), (TF3, TF0), (TF4, TF0), (TF5, TF0), (TF6, TF0), (TF7, TF0), (TF8, TF0), (TF9, TF0), (TF10, TF0), (TF0, TF1), (TF1, TF1), (TF2, TF1), (TF3, TF1), (TF4, TF1), (TF5, TF1), (TF6, TF1), (TF7, TF1), (TF8, TF1), (TF9, TF1), (TF10, TF1)

NOTE: The TFCs (TF0, TF0), (TF10, TF0) and (TF0, TF1) are belonging to minimum set of TFCs.

C.4.2 DL reference measurement channel for BTFD performance requirements

The parameters for DL reference measurement channel for BTFD are specified in table C.4.2.1, table C.4.2.2, table C.4.2.3 and table C.4.2.4. The channel coding for information is shown in figures C.4.1, C.4.2, and C.4.3. For the RLC configuration of AM DCCHs Timer_STATUS_Periodic shall not be set in RRC CONNECTION SETUP message used in test procedure for RF test as defined in TS 34.108 [3] clause 7.3. This is to prevent unexpected DCHs from being transmitted through such RLC entities when the timer has expired in order to ensure that the required TFC from the minimum set of TFCs can continuously convey a DCH for DTCH during the test.

Table C.4.2.1: DL reference measurement channel physical parameters for BTFD

Parameter	Rate 1	Rate 2	Rate 3	Unit
Information bit rate	12,2	7,95	1,95	kbps
DPCH	30			ksps
Slot Format #1	8			-
TFC1	Off			-
Power offsets PO1, PO2 and PO3	0			dB
DTX position	Fixed			-

Table C.4.2.2: DL reference measurement channel, transport channel parameters for SRB

Higher Layer	RAB/Signalling RB	SRB	
RLC	Logical channel type	DCCH	
	RLC mode	UM/AM	
	Payload sizes, bit	88/80	
	Max data rate, bps	2200/2000	
	PDU header, bit	8/16	
	TrD PDU header, bit	N/A	
MAC	MAC header, bit	4	
	MAC multiplexing	Yes	
Layer 1	TrCH type	DCH	
	Transport Channel Identity	20	
	TB sizes, bit	100	
	TFS	TF0, bits	0*100
		TF1, bits	1*100
	TTI, ms	40	
	Coding type	Convolution Coding	
	Coding Rate	1/3	
	CRC, bit	12	
	Max number of bits/TTI after channel coding	360	
	Uplink: Max number of bits/radio frame before rate matching	90	
	RM attribute	256	

Table C.4.2.3: DL reference measurement channel using RLC-TM for DTCH, transport channel parameters

Higher Layer	RAB/Signalling RB	12.2k/10.2k/7.95k/7.4k/6.7k/5.9k/5.15k/4.75k/1.95k	
RLC	Logical channel type	DTCH	
	RLC mode	TM	
	Payload sizes, bit	244, 204, 159, 148, 134, 118, 103, 95, 39	
	Max data rate, bps	12200	
	PDU header, bit	N/A	
	TrD PDU header, bit	0	
MAC	MAC header, bit	0	
	MAC multiplexing	N/A	
Layer 1	TrCH type	DCH	
	Transport Channel Identity	1	
	TB sizes, bit	244, 204, 159, 148, 134, 118, 103, 95, 39	
	TFS	TF0 bit	1x244
		TF1 bit	1x204
		TF2 bit	1x159
		TF3 bit	1x148
		TF4 bit	1x134
		TF5 bit	1x118
		TF6 bit	1x103
		TF7 bit	1x95
		TF8 bit	1x39
	TTI, ms	20	
	Coding type	CC	
Coding Rate	1/3		
CRC, bit	12		
RM attribute	256		

Table C.4.2.4: DL reference measurement channel, TFCS

TFCS size	18
TFCS	(DTCH, DCCH)= (TF0, TF0), (TF1, TF0), (TF2, TF0), (TF3, TF0), (TF4, TF0), (TF5, TF0), (TF6, TF0), (TF7, TF0), (TF8, TF0), (TF0, TF1), (TF1, TF1), (TF2, TF1), (TF3, TF1), (TF4, TF1), (TF5, TF1), (TF6, TF1), (TF7, TF1), (TF8, TF1)

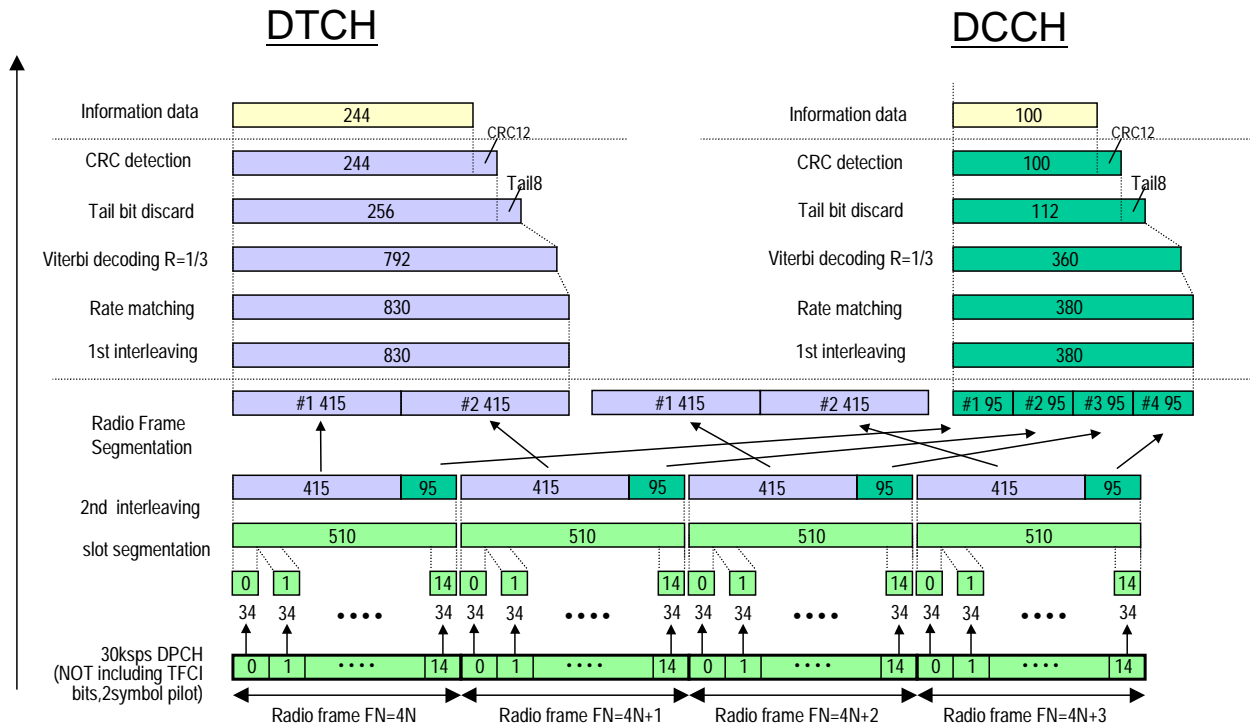

Figure C.4.1 (informative): Channel coding of DL reference measurement channel for BTFD (Rate 1)

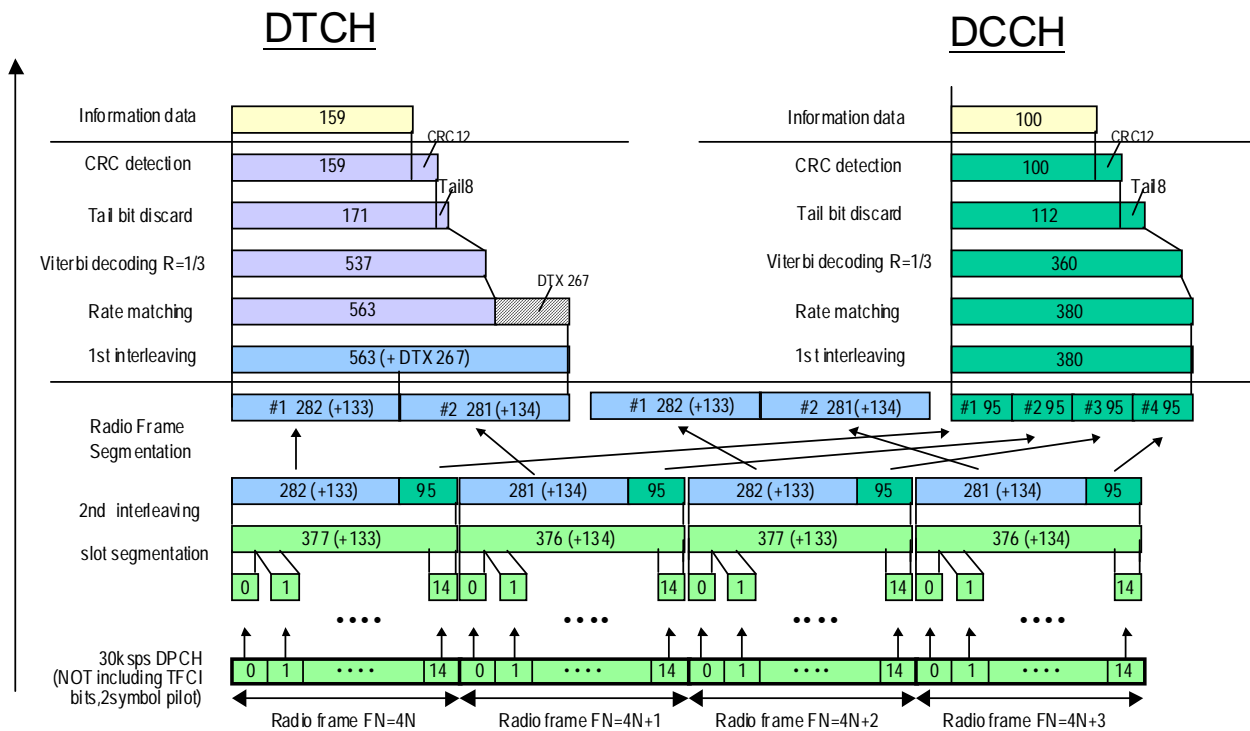

Figure C.4.2 (informative): Channel coding of DL reference measurement channel for BTFD (Rate 2)

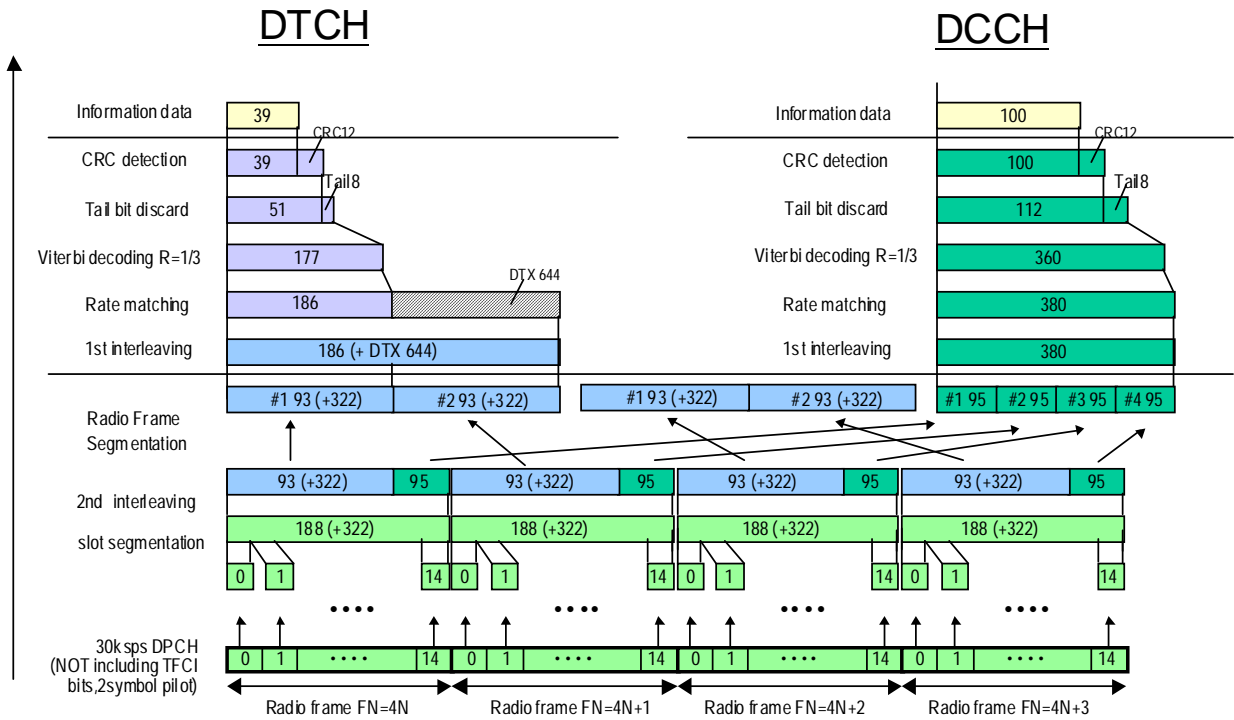

Figure C.4.3 (informative): Channel coding of DL reference measurement channel for BTFD (Rate 3)

C.5 DL reference compressed mode parameters

Parameters described in table C.5.1 are used in some test specified in TS 25.101 while parameters described in table C.5.2 are used in some tests specified in TS 25.133 [2].

Set 1 parameters in table C.5.1 are applicable when compressed mode by spreading factor reduction is used in downlink. Set 2 parameters in table C.5.1 are applicable when compressed mode by puncturing is used in downlink. Set 2 is applicable for Release 99 and Release 4 only.

Table C.5.1: Compressed mode reference pattern 1 parameters

Parameter	Set 1	Set 2	Note
TGSN (Transmission Gap Starting Slot Number)	11	11	
TGL1 (Transmission Gap Length 1)	7	7	
TGL2 (Transmission Gap Length 2)	-	-	Only one gap in use.
TGD (Transmission Gap Distance)	0	0	Only one gap in use. UNDEFINED is used for TGD.
TGPL1 (Transmission Gap Pattern Length)	4	4	
TGPL2 (Transmission Gap Pattern Length)	-	-	R99 and Rel-4: Only one pattern in use. Rel-5 and later releases: Not applicable
TGPRC (Transmission Gap Pattern Repetition Count)	NA	NA	Defined by higher layers
TGCFN (Transmission Gap Connection Frame Number):	NA	NA	Defined by higher layers
UL/DL compressed mode selection	DL & UL	DL & UL	2 configurations possible DL & UL / DL
UL compressed mode method	SF/2	SF/2	
DL compressed mode method	SF/2	Puncturing	Compressed mode by puncturing is applicable for R99 and Rel-4 only.
Downlink frame type and Slot format	11B	11A	
Scrambling code change	No	No	
RPP (Recovery period power control mode)	0	0	
ITP (Initial transmission power control mode)	0	0	

Table C.5.2: Compressed mode reference pattern 2 parameters

Parameter	Set 1	Set 2	Set 3	Set 4	Note
TGSN (Transmission Gap Starting Slot Number)	4	4	10	8	
TGL1 (Transmission Gap Length 1)	7	7	10	14	
TGL2 (Transmission Gap Length 2)	-	-	-	-	Only one gap in use.
TGD (Transmission Gap Distance)	0	0	0	0	UNDEFINED is used for TGD.
TGPL1 (Transmission Gap Pattern Length)	3	12	11	4	
TGPL2 (Transmission Gap Pattern Length)	-	-	-	-	R99 and Rel-4: Only one pattern in use. Rel-5 and later releases: Not applicable
TGPRC (Transmission Gap Pattern Repetition Count)	NA	NA	NA	NA	Defined by higher layers
TGCFN (Transmission Gap Connection Frame Number):	NA	NA	NA	NA	Defined by higher layers
UL/DL compressed mode selection	DL & UL	DL & UL	DL & UL	DL & UL	2 configurations possible. DL & UL / DL
UL compressed mode method	SF/2	SF/2	SF/2	SF/2	
DL compressed mode method	SF/2	SF/2	Puncturing	SF/2	Compressed mode by puncturing is applicable for R99 and Rel-4 only.
Downlink frame type and Slot format	11B	11B	11A	11B	
Scrambling code change	No	No	No	No	
RPP (Recovery period power control mode)	0	0	0	0	
ITP (Initial transmission power control mode)	0	0	0	0	

Table C.5.3: Compressed mode reference pattern 3 parameters

Parameter	Set 1	Set 2	Set 3	Set 4	Note
TGSN (Transmission Gap Starting Slot Number)	8	8	8	8	
TGL1 (Transmission Gap Length 1)	14	14	14	14	
TGL2 (Transmission Gap Length 2)	-	-	-	-	Only one gap in use.
TGD (Transmission Gap Distance)	0	0	0	0	UNDEFINED is used for TGD.
TGPL1 (Transmission Gap Pattern Length)	8	24	24	24	
TGPRC (Transmission Gap Pattern Repetition Count)	NA	NA	NA	NA	Defined by higher layers
TGCFN (Transmission Gap Connection Frame Number):	0	4	12	20	
UL/DL compressed mode selection	DL & UL	DL & UL	DL & UL	DL & UL	2 configurations possible. DL & UL / DL
UL compressed mode method	SF/2	SF/2	SF/2	SF/2	
DL compressed mode method	SF/2	SF/2	SF/2	SF/2	
Downlink frame type and Slot format	11B	11B	11B	11B	
Scrambling code change	No	No	No	No	
RPP (Recovery period power control mode)	0	0	0	0	
ITP (Initial transmission power control mode)	0	0	0	0	

C.6 Auxiliary measurement channels

C.6.1 Introduction

BLER measurements for test cases where the UL data rate is less or equal to the DL data rate require that special auxiliary measurement channels (AUXMC) are used. This annex specifies the alternative auxiliary measurement channels and the UE test loop mode parameters to be used for the different UL and DL data rate combinations.

C.6.2 Channel combinations for BLER measurements

Table C.6.2: BLER test method and measurement channels for BLER tests for UL DL data rate combinations

DL rate [kbps]	UE UL RMC rate capability [kbps]	BLER Test method	DL RMC	UL RMC	UE test loop mode (Note 1)	Comments
12.2	RMC 12.2	Loopback Data+CRC	DL TM RMC 12.2 kbps See C.3.1	UL TM AUXMC 12.2 kbps, no CRC See C.6.3	2	Perform test in CS domain.
64	RMC 12.2	AM ACK/NACK	DL AM RMC 64 kbps See C.3.2	UL AM AUXMC 12.2 kbps See C.6.7	1	DL RLC SDU size=1248 UL RLC SDU size=0 See Note 2 Perform test in PS domain.
144	RMC 12.2	AM ACK/NACK	DL AM RMC 144 kbps See C.3.3	UL AM AUXMC 12.2 kbps See C.6.7	1	DL RLC SDU size=2848 UL RLC SDU size=0 See Note 3 Perform test in PS domain.
384	RMC 12.2	AM ACK/NACK	DL AM RMC 384 kbps See C.3.4	UL AM AUXMC 12.2 kbps See C.6.7	1	DL RLC SDU size=3808 UL RLC SDU size=0 See Note 4 Perform test in PS domain.
Note 1	See TS 34.109 [4] for details regarding UE test loop modes. See TS 34.109 [4] Annex A.3 for description of the BLER test method using TM reference measurement channel and UE test loop mode 2 (Loopback Data+CRC). See TS 34.109 [4] Annex A.2 for BLER test method using AM reference measurement channels and UE test loop mode 1 (AM ACK/NACK).					
Note 2	The DL AM RMC for 64 kbps according to clause C.3.2 table C.3.2.3 has payload size = 1264 bits and TTI = 20 ms. The SS sends one RLC SDU of size 1248 bits (payload size of 1264 bits – 16 bits for length indicator and extension bit) every downlink TTI (20 ms). The UE test loop parameter “UL RLC SDU size” is set to 0 (no data will be returned) in order to avoid UE buffer overflows.					
Note 3	The DL AM RMC for 144 kbps according to clause C.3.3 table C.3.3.3 has payload size = 2864 bits and TTI = 20 ms. The SS sends one RLC SDU of size 2848 bits (payload size of 2864 bits – 16 bits for length indicator and extension bit) every downlink TTI (20 ms). The UE test loop parameter “UL RLC SDU size” is set to 0 (no data will be returned) in order to avoid UE buffer overflows.					
Note 4	The DL AM RMC for 384 kbps according to clause C.3.4 table C.3.4.3 has a payload size of 3824 bits and a TTI of 10 ms. The SS sends one RLC SDU of size 3808 bits (=payload size of 3824 bits – 16 bits for length indicator and extension bit) every downlink TTI (10 ms). The UE test loop parameter “UL RLC SDU size” set to 0 (no data will be returned) in order to avoid UE buffer overflows.					

C.6.3 UL auxiliary reference measurement channel (TM, 12.2 kbps, no CRC)

Table C.6.3: UL AUXMC TM 12.2 kbps (13 kbps), no CRC

Higher Layer	RAB/Signalling RB	RAB	SRB	
RLC	Logical channel type	DTCH	DCCH	
	RLC mode	TM	UM/AM	
	Payload sizes, bit	260	88/80	
	Max data rate, bps	13000	2200/2000	
	PDU header, bit	N/A	8/16	
	TrD PDU header, bit	0	N/A	
MAC	MAC header, bit	0	4	
	MAC multiplexing	N/A	Yes	
Layer 1	TrCH type	DCH	DCH	
	Transport Channel Identity	1	5	
	TB sizes, bit	260	100	
	TFS	TF0, bits	0*260	0*100
		TF1, bits	1*260	1*100
	TTI, ms	20	40	
	Coding type	Convolution Coding	Convolution Coding	
	Coding Rate	1/3	1/3	
	CRC, bit	0	12	
	Max number of bits/TTI after channel coding	804	360	
	Uplink: Max number of bits/radio frame before rate matching	402	90	
	RM attribute	256	256	

C.6.3A UL auxiliary reference measurement channel (TM, 0 kbps and 12.2 kbps, no CRC)

Table C.6.3A: UL AUXMC TM 0 kbps (400 bps) and 12.2 kbps (13 kbps), no CRC

Higher Layer	RAB/Signalling RB	RAB	SRB	
RLC	Logical channel type	DTCH	DCCH	
	RLC mode	TM	UM/AM	
	Payload sizes, bit	260/16	88/80	
	Max data rate, bps	13000/400	2200/2000	
	PDU header, bit	N/A	8/16	
	TrD PDU header, bit	0	N/A	
MAC	MAC header, bit	0	4	
	MAC multiplexing	N/A	Yes	
Layer 1	TrCH type	DCH	DCH	
	Transport Channel Identity	1	5	
	TB sizes, bit	260	100	
	TFS	TF0, bits	0*260	0*100
		TF1, bits	1*260	1*100
		TF2, bits	1*16	-
	TTI, ms	20	40	
	Coding type	Convolution Coding	Convolution Coding	
	Coding Rate	1/3	1/3	
	CRC, bit	0	12	
	Max number of bits/TTI after channel coding	804	360	
	Uplink: Max number of bits/radio frame before rate matching	402	90	
	RM attribute	256	256	

C.6.4 Void

Table C.6.4: Void

C.6.5 Void

Table C.6.5: Void

C.6.6 Void

Table C.6.6: Void

C.6.7 UL AUXMC AM 12.2 kbps

Table C.6.7: UL AUXMC AM 12.2 kbps (11.2 kbps)

Higher Layer	RAB/Signalling RB	RAB	SRB	
RLC	Logical channel type	DTCH	DCCH	
	RLC mode	AM	UM/AM	
	Payload sizes, bit	224	88/80	
	Max data rate, bps	11200	2200/2000	
	PDU header, bit	16	8/16	
	TrD PDU header, bit	N/A	N/A	
MAC	MAC header, bit	0	4	
	MAC multiplexing	N/A	Yes	
Layer 1	TrCH type	DCH	DCH	
	Transport Channel Identity	1	5	
	TB sizes, bit	240	100	
	TFS	TF0, bits	0*240	0*100
		TF1, bits	1*240	1*100
	TTI, ms	20	40	
	Coding type	Convolution Coding	Convolution Coding	
	Coding Rate	1/3	1/3	
	CRC, bit	16	12	
	Max number of bits/TTI after channel coding	792	360	
	Uplink: Max number of bits/radio frame before rate matching	396	90	
	RM attribute	256	256	

C.7 DL reference parameters for PCH tests

The parameters for the PCH demodulation tests are specified in table C.7.1 and table C.7.2.

Table C.7.1: Physical channel parameters for S-CCPCH

Parameter	Unit	Level
Channel bit rate	Kbps	60
Channel symbol rate	Ksps	30
Slot Format #1	-	4
TFCI	-	OFF
Power offsets of TFCI and Pilot fields relative to data field	dB	0

Table C.7.2: Transport channel parameters for S-CCPCH

Parameter	PCH
Transport Channel Number	1
Transport Block Size	240
Transport Block Set Size	240
Transmission Time Interval	10 ms
Type of Error Protection	Convolution Coding
Coding Rate	1/2
Rate Matching attribute	256
Size of CRC	16
Position of TrCH in radio frame	fixed

C.8 DL reference channel parameters for HSDPA tests

C.8.1 Fixed Reference Channel (FRC)

C.8.1.1 Fixed Reference Channel Definition H-Set 1

Table C.8.1.1: Fixed Reference Channel H-Set 1

Parameter	Unit	Value	
Nominal Avg. Inf. Bit Rate	kbps	534	777
Inter-TTI Distance	TTI's	3	3
Number of HARQ Processes	Processes	2	2
Information Bit Payload (N_{INF})	Bits	3202	4664
MAC-d PDU size	Bits	336	336
Number Code Blocks	Blocks	1	1
Binary Channel Bits Per TTI	Bits	4800	7680
Total Available SML's in UE	SML's	19200	19200
Number of SML's per HARQ Proc.	SML's	9600	9600
Coding Rate		0.67	0.61
Number of Physical Channel Codes	Codes	5	4
Modulation		QPSK	16QAM
Note:	The HS-DSCH shall be transmitted continuously with constant power but only every third TTI shall be allocated to the UE under test		

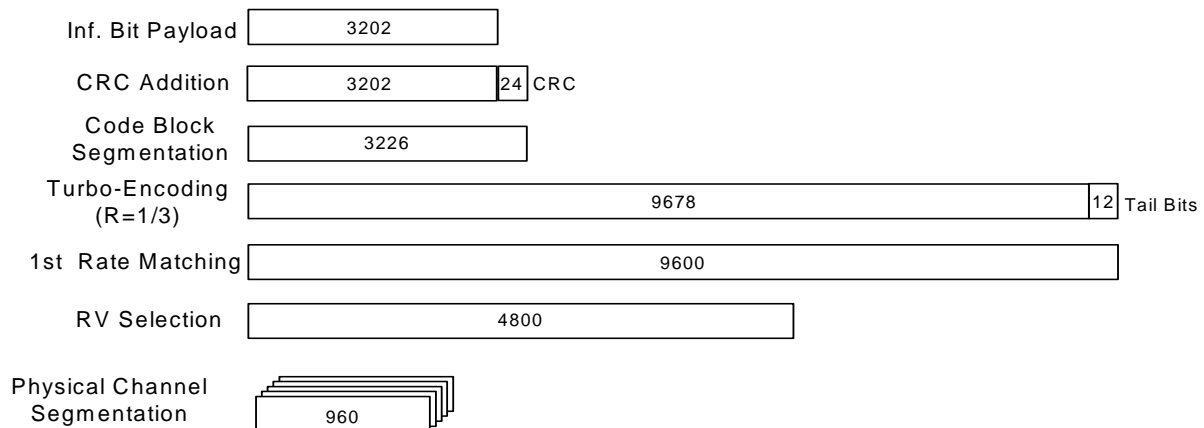

Figure C.8.1: Coding rate for Fixed reference Channel H-Set 1 (QPSK)

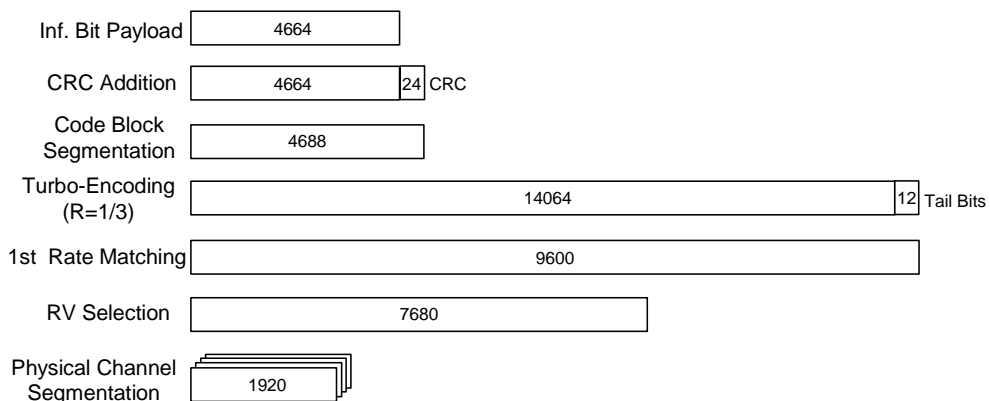

Figure C.8.2: Coding rate for Fixed reference Channel H-Set 1 (16 QAM)

C.8.1.2 Fixed Reference Channel Definition H-Set 2

Table C.8.1.2: Fixed Reference Channel H-Set 2

Parameter	Unit	Value	
Nominal Avg. Inf. Bit Rate	kbps	801	1166
Inter-TTI Distance	TTI's	2	2
Number of HARQ Processes	Processes	3	3
Information Bit Payload (N_{INF})	Bits	3202	4664
MAC-d PDU size	Bits	336	336
Number Code Blocks	Blocks	1	1
Binary Channel Bits Per TTI	Bits	4800	7680
Total Available SML's in UE	SML's	28800	28800
Number of SML's per HARQ Proc.	SML's	9600	9600
Coding Rate		0.67	0.61
Number of Physical Channel Codes	Codes	5	4
Modulation		QPSK	16QAM
Note: The HS-DSCH shall be transmitted continuously with constant power but only every second TTI shall be allocated to the UE under test			

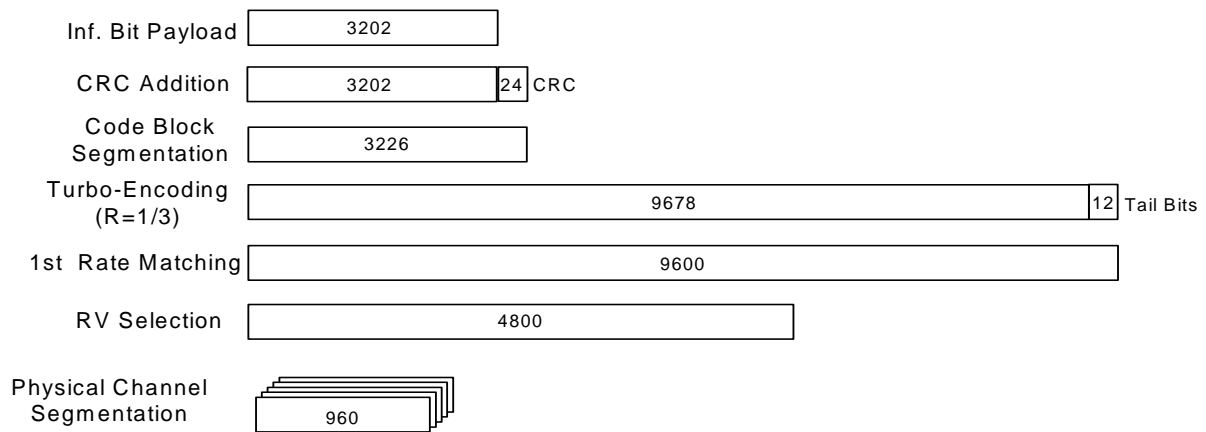

Figure C.8.3: Coding rate for Fixed Reference Channel H-Set 2 (QPSK)

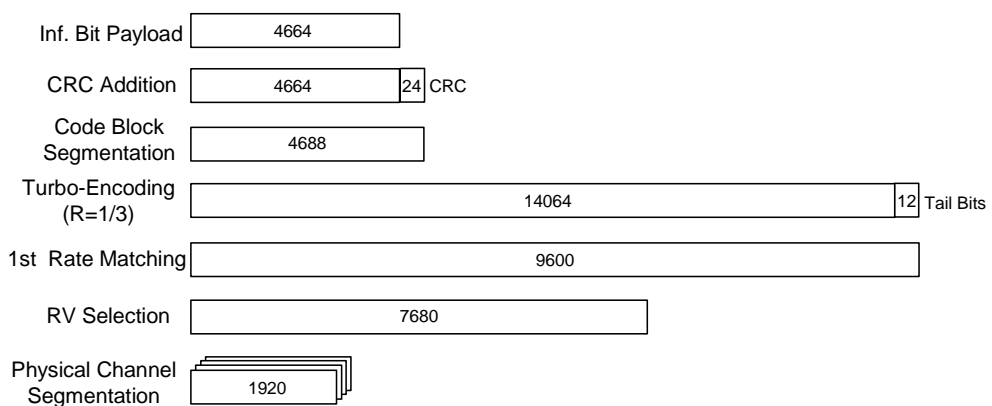

Figure C.8.4: Coding rate for Fixed Reference Channel H-Set 2 (16QAM)

C.8.1.3 Fixed Reference Channel Definition H-Set 3

Table C.8.1.3: Fixed Reference Channel H-Set 3

Parameter	Unit	Value	
Nominal Avg. Inf. Bit Rate	kbps	1601	2332
Inter-TTI Distance	TTI's	1	1
Number of HARQ Processes	Processes	6	6
Information Bit Payload (N_{INF})	Bits	3202	4664
MAC-d PDU size	Bits	336	336
Number Code Blocks	Blocks	1	1
Binary Channel Bits Per TTI	Bits	4800	7680
Total Available SML's,in UE	SML's	57600	57600
Number of SML's per HARQ Proc.	SML's	9600	9600
Coding Rate		0.67	0.61
Number of Physical Channel Codes	Codes	5	4
Modulation		QPSK	16QAM

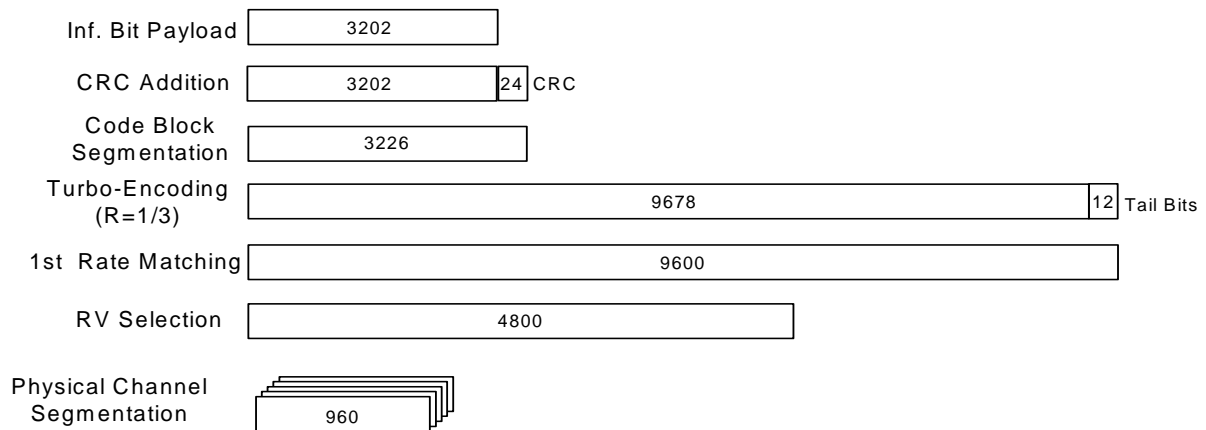

Figure C.8.5: Coding rate for Fixed reference Channel H-Set 3 (QPSK)

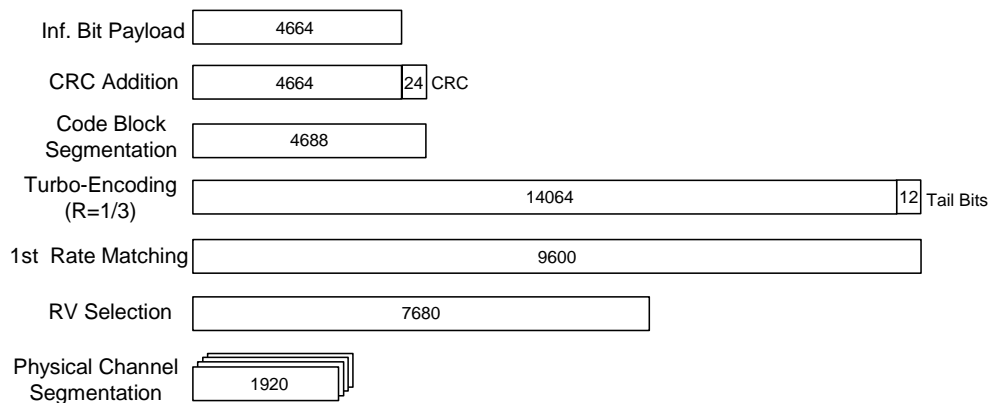

Figure C.8.6: Coding rate for Fixed reference Channel H-Set 3 (16QAM)

C.8.1.4 Fixed Reference Channel Definition H-Set 4

Table C.8.1.4: Fixed Reference Channel H-Set 4

Parameter	Unit	Value
Nominal Avg. Inf. Bit Rate	kbps	534
Inter-TTI Distance	TTI's	2
Number of HARQ Processes	Processes	2
Information Bit Payload (N_{INF})	Bits	3202
MAC-d PDU Size	Bits	336
Number Code Blocks	Blocks	1
Binary Channel Bits Per TTI	Bits	4800
Total Available SML's in UE	SML's	14400
Number of SML's per HARQ Proc.	SML's	7200
Coding Rate		0.67
Number of Physical Channel Codes	Codes	5
Modulation		QPSK
Note:	This FRC is used to verify the minimum inter-TTI distance for UE category 11. The HS-PDSCH shall be transmitted continuously with constant power. The six sub-frame HS-SCCH signalling pattern shall repeat as follows: ...OOXOXOOXOXO..., where 'X' marks TTI in which HS-SCCH uses the identity of the UE under test and 'O' marks TTI in which HS-SCCH uses a different identity.	

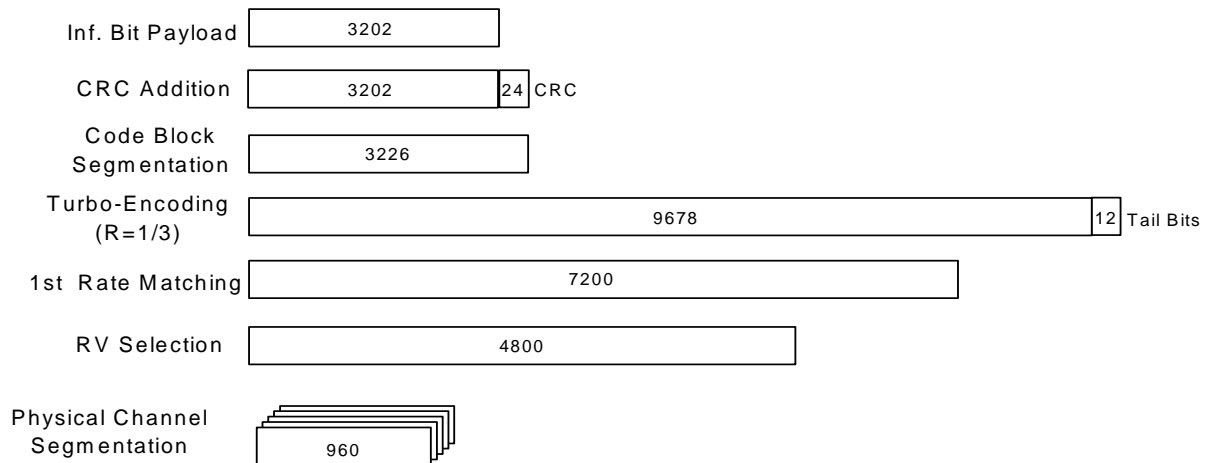

Figure C.8.7: Coding rate for Fixed Reference Channel H-Set 4

C.8.1.5 Fixed Reference Channel Definition H-Set 5

Table C.8.1.5: Fixed Reference Channel H-Set 5

Parameter	Unit	Value
Nominal Avg. Inf. Bit Rate	kbps	801
Inter-TTI Distance	TTI's	1
Number of HARQ Processes	Processes	3
Information Bit Payload (N_{INF})	Bits	3202
MAC-d PDU Size	Bits	336
Number Code Blocks	Blocks	1
Binary Channel Bits Per TTI	Bits	4800
Total Available SML's in UE	SML's	28800
Number of SML's per HARQ Proc.	SML's	9600
Coding Rate		0.67
Number of Physical Channel Codes	Codes	5
Modulation		QPSK
Note: This FRC is used to verify the minimum inter-TTI distance for UE category 12. The HS-PDSCH shall be transmitted continuously with constant power. The six sub-frame HS-SCCH signalling pattern shall repeat as follows: ...OOXXXOOOXXO..., where 'X' marks TTI in which HS-SCCH uses the identity of the UE under test and 'O' marks TTI in which HS-SCCH uses a different identity.		

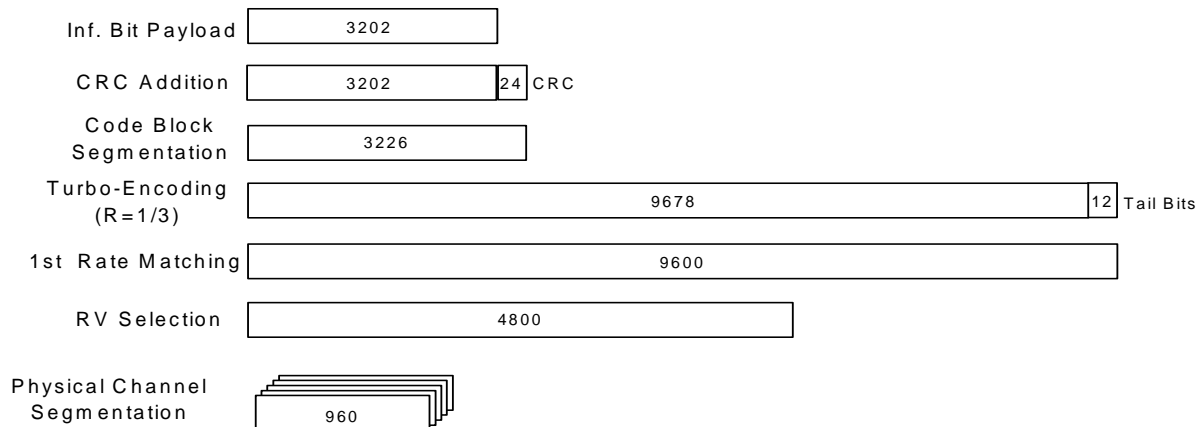

Figure C.8.8: Coding rate for Fixed Reference Channel H-Set 5

C.8.1.6 Fixed Reference Channel Definition H-Set 6

Table C.8.1.6: Fixed Reference Channel H-Set 6

Parameter	Unit	Value	
Nominal Avg. Inf. Bit Rate	kbps	3219	4689
Inter-TTI Distance	TTI's	1	1
Number of HARQ Processes	Processes	6	6
Information Bit Payload (N_{INF})	Bits	6438	9377
Mac-d PDU Size	Bits	336	336
Number Code Blocks	Blocks	2	2
Binary Channel Bits Per TTI	Bits	9600	15360
Total Available SML's in UE	SML's	115200	115200
Number of SML's per HARQ Proc.	SML's	19200	19200
Coding Rate		0.67	0.61
Number of Physical Channel Codes	Codes	10	8
Modulation		QPSK	16QAM

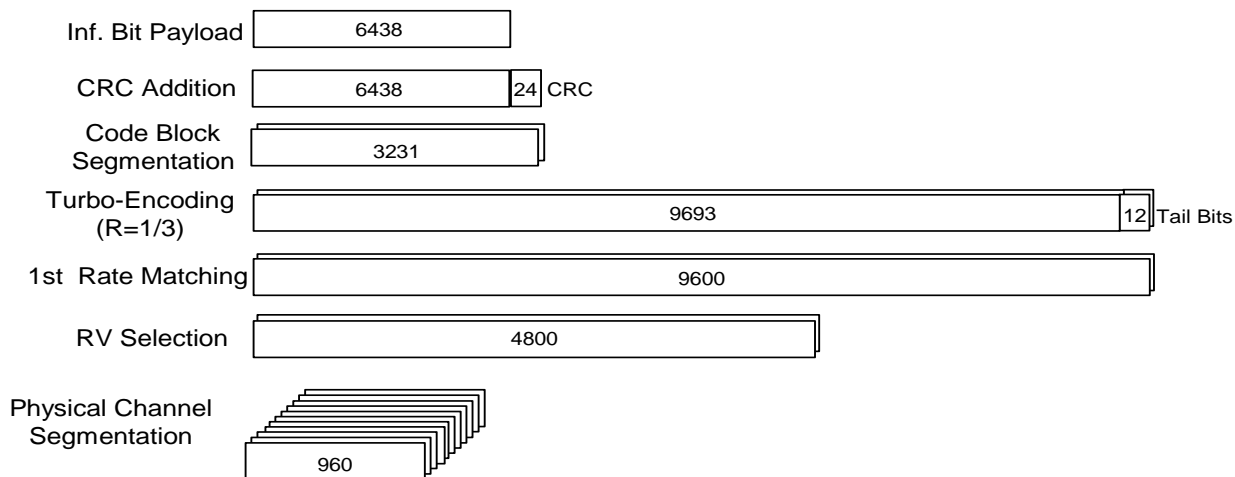

Figure C.8.9: Coding rate for Fixed reference Channel H-Set 6 (QPSK)

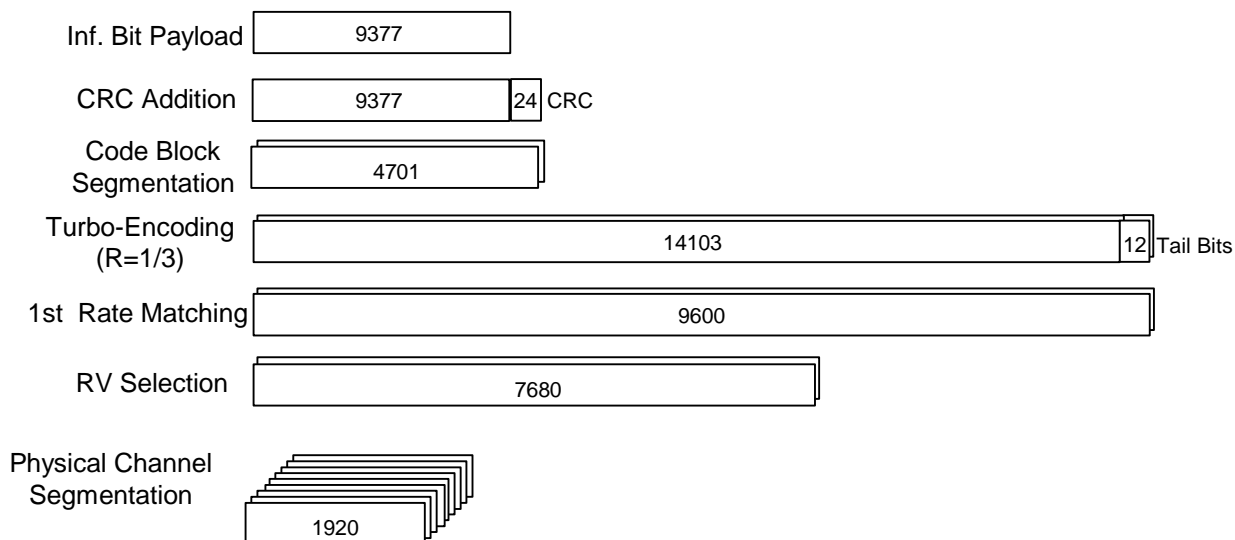

Figure C.8.10: Coding rate for Fixed reference Channel H-Set 6 (16 QAM)

C.9 Downlink reference channel dummy DCCH transmission on DCH

Many test cases have been designed to have continuous downlink DCCH transmission on DCH. The DCCH is carrying SRBs. When there are no signalling messages to be transmitted on downlink DCCH then dummy DCCH messages shall be transmitted on the downlink.

For all test cases with continuous downlink DCCH transmission on DCH the format of the dummy DCCH message is using an invalid MAC header with the value "1111" for the C/T field. The UE shall discard PDU's with this invalid MAC header according to TS 25.321. This applies for cases where a MAC header is used to distinguish between several logical channels. In the case of the reference measurement channels the SRBs on DCH use a 4 bit MAC header.

C.9A MAC header transmission on HS-DSCH

For all test cases with HS-DSCH transmission either a correct MAC-hs header consistent with the actual HSDPA transmission is used or an inconsistent MAC-hs header with the value "111" for the SID field is used. If an inconsistent MAC-hs header is used, then the UE shall discard PDU's according to TS 25.321[13] section 10. For other fields the

MAC-hs header shall be set according to the HS-DSCH configuration configured by RRC and the actual HS-DSCH transmission in order to avoid unspecified UE behavior.

C.10 UL reference channel parameters for HSDPA tests

This annex specifies the UL reference channels in for HSDPA test cases and the UE test loop mode parameters to be used when the UL reference measurement channel (12.2 kbps) from C.2.1 does not support the required test conditions. Transmitter characteristics tests with HS-DPCCH require continuous transmission and test loop operation on UL DPCH.

C.10.1 UL reference measurement channel for HSDPA tests

Table C.10.1.1 to C.10.1.4 are applicable for tests on Transmitter Characteristics with HSDPA in clauses 5.2A, 5.2C, 5.2AA, 5.7A, 5.9A, 5.10A, 5.13.1A and 5.13.1AA.

Table C.10.1.1: UL reference measurement channel physical parameters (12.2 kbps) for HSDPA tests

Parameter	Level	Unit
DPCCH/DPDCH power ratio	-5.46 (Note 1)	dB
Note 1:	The power ratio for transmitter characteristics testing with HS-DPCCH depends on the beta values given in table C.10.1.4.	
Note 2:	With the exception of the DPCCH/DPDCH power ratio parameter in this table all other parameters are defined in UL reference measurement channel in clause C.2.1, table C.2.1.1.	

Table C.10.1.2: UL reference measurement channel, transport channel parameters (12.2 kbps) for HSDPA

Higher Layer	RAB/Signalling RB	RAB	SRB
Note:	As defined in UL reference measurement channel in clause C.2.1, table C.2.1.2.		

Table C.10.1.3: UL reference measurement channel, TFCS (12.2 kbps) for HSDPA

Note:	As defined in UL reference measurement channel in clause C.2.1, table C.2.1.3.
-------	--

Table C.10.1.4: β values for transmitter characteristics tests with HS-DPCCH

Sub-test	β_c	β_d	β_d (SF)	β_c/β_d	β_{HS} (Note 1, Note 2)	CM (dB) (Note 3)	MPR (dB) (Note 3)
1	2/15	15/15	64	2/15	4/15	0.0	0.0
2	12/15 (Note 4)	15/15 (Note 4)	64	12/15 (Note 4)	24/15	1.0	0.0
3	15/15	8/15	64	15/8	30/15	1.5	0.5
4	15/15	4/15	64	15/4	30/15	1.5	0.5
Note 1:	Δ_{ACK} , Δ_{NACK} and $\Delta_{CQI} = 30/15$ with $\beta_{HS} = 30/15 * \beta_c$.						
Note 2:	For the HS-DPCCH power mask requirement test in clause 5.2C, 5.7A, and the Error Vector Magnitude (EVM) with HS-DPCCH test in clause 5.13.1A, and HSDPA EVM with phase discontinuity in clause 5.13.1AA, Δ_{ACK} and $\Delta_{NACK} = 30/15$ with $\beta_{HS} = 30/15 * \beta_c$, and $\Delta_{CQI} = 24/15$ with $\beta_{HS} = 24/15 * \beta_c$.						
Note 3:	CM = 1 for $\beta_c/\beta_d = 12/15$, $\beta_{HS}/\beta_c = 24/15$. For all other combinations of DPDCH, DPCCH and HS-DPCCH the MPR is based on the relative CM difference. This is applicable for only UEs that support HSDPA in release 6 and later releases.						
Note 4:	For subtest 2 the β_c/β_d ratio of 12/15 for the TFC during the measurement period (TF1, TF0) is achieved by setting the signalled gain factors for the reference TFC (TF1, TF0) to $\beta_c = 11/15$ and $\beta_d = 15/15$.						

C.11 Reference channel parameters for E-DCH tests

This annex specifies the reference channel parameters for E-DCH test cases.

C.11.1 UL reference measurement channel for E-DCH tests

On uplink E-DCH the MAC-d flow parameters and the physical channel parameters according to default Radio Bearer Setup message of section 9.2.1 of TS 34.108 are used. On uplink DCH the reference measurement channel according to section C.2.1 is used with the exception that for transmitter characteristics tests the DPCCH/DPDCH power ratio depends on the beta values given in table C.11.1.3. For transmitter characteristics tests the beta values on all uplink channels according to table C.11.1.3. are used.

Table C.11.1.1: Void

Table C.11.1.2: Void

Table C.11.1.3: β values for transmitter characteristics tests with HS-DPCCH and E-DCH

Sub-test	β_c	β_d	β_d (SF)	β_o/β_d	β_{HS} (Note 1)	β_{ec}	β_{ed} (Note 5) (Note 6)	β_{ed} (SF)	β_{ed} (Codes)	CM (dB) (Note 2)	MPR (dB) (Note 2)	AG Index (Note 6)	E-TFCI
1	11/15 (Note 3)	15/15 (Note 3)	64	11/15 (Note 3)	22/15	209/25	1309/225	4	1	1.0	0.0	20	75
2	6/15	15/15	64	6/15	12/15	12/15	94/75	4	1	3.0	2.0	12	67
3	15/15	9/15	64	15/9	30/15	30/15	β_{ed1} : 47/15 β_{ed2} : 47/15	4	2	2.0	1.0	15	92
4	2/15	15/15	64	2/15	4/15	2/15	56/75	4	1	3.0	2.0	17	71
5	15/15 (Note 4)	15/15 (Note 4)	64	15/15 (Note 4)	30/15	24/15	134/15	4	1	1.0	0.0	21	81

Note 1: Δ_{ACK} , Δ_{NACK} and $\Delta_{CQI} = 30/15$ with $\beta_{hs} = 30/15 * \beta_c$.

Note 2: CM = 1 for $\beta_o/\beta_d = 12/15$, $\beta_{hs}/\beta_c = 24/15$. For all other combinations of DPDCH, DPCCH, HS-DPCCH, E-DPDCH and E-DPCCH the MPR is based on the relative CM difference.

Note 3: For subtest 1 the β_o/β_d ratio of 11/15 for the TFC during the measurement period (TF1, TF0) is achieved by setting the signalled gain factors for the reference TFC (TF1, TF1) to $\beta_c = 10/15$ and $\beta_d = 15/15$.

Note 4: For subtest 5 the β_o/β_d ratio of 15/15 for the TFC during the measurement period (TF1, TF0) is achieved by setting the signalled gain factors for the reference TFC (TF1, TF1) to $\beta_c = 14/15$ and $\beta_d = 15/15$.

Note 5: In case of testing by UE using E-DPDCH Physical Layer category 1, Sub-test 3 is omitted according to TS25.306 Table 5.1g.

Note 6: β_{ed} can not be set directly, it is set by Absolute Grant Value.

C.11.2 DL reference measurement channel for E-DCH tests

On downlink DCH the reference measurement channel according to section C.3.1 is used. On downlink HS-DSCH the fixed reference channel H-Set 1 according to section C.8.1.1 is used.

C.11.3 RLC SDU size for E-DCH tests

The DL RLC SDU size for all E-DCH tests is set to 2936bits and UL RLC SDU size for all E-DCH tests is shown in Table C.11.3.1

Table C.11.3.1: UL RLC SDU size for E-DCH tests

TC Clause	TS 34.121-1 E-DCH Test Cases	UL RLC SDU Size (Note)
5.2B	Maximum Output Power with HS-DPCCH and E-DCH	2936bits (1*DL RLC SDU)
5.2D	UE Relative Code Domain Power Accuracy for HS-DPCCH and E-DCH	2936bits (1*DL RLC SDU)
5.9B	Spectrum Emission Mask with E-DCH	2936bits (1*DL RLC SDU)
5.10B	ACLR with E-DCH	2936bits (1*DL RLC SDU)
5.13.2B	Relative Code Domain Error with HS-DPCCH and E-DCH	2936bits (1*DL RLC SDU)
8.4.4.1	10 ms TTI E-DCH E-TFC Restriction	11744bits (4*DL RLC SDU)
8.4.4.2	2ms TTI E-DCH E-TFC Restriction	35232bits (12*DL RLC SDU)
8.7.9	UE Transmission Power Headroom	No E-DCH payload data transmitted
10.2.1.1	Detection of E-HICH -Single Link Performance (10ms)	2936bits (1*DL RLC SDU)
10.2.1.2	Detection of E-HICH -Single Link Performance (2ms)	5872bits (2*DL RLC SDU)
10.2.2.1.1	Detection in Inter-Cell Handover conditions- RLS not containing the Serving E-DCH cell (10ms)	11744bits (4*DL RLC SDU)
10.2.2.1.2	Detection in Inter-Cell Handover conditions- RLS not containing the Serving E-DCH cell (2ms)	17616bits (6*DL RLC SDU)
10.2.2.2.1	Detection in Inter-Cell Handover conditions- RLS containing the Serving E-DCH cell (10ms)	17616bits (6*DL RLC SDU)
10.2.2.2.2	Detection in Inter-Cell Handover conditions- RLS containing the Serving E-DCH cell (2ms)	29360bits (10*DL RLC SDU)
10.3.1.1	Detection of E-RGCH - Single Link Performance (10ms)	2936bits (1*DL RLC SDU)
10.3.1.2	Detection of E-RGCH - Single Link Performance (2ms)	5872bits (2*DL RLC SDU)
10.3.2	Detection of E-RGCH - Detection in Inter-Cell Handover conditions	11744bits (4*DL RLC SDU)
10.4.1	Demodulation of E-AGCH (Single Link Performance)	8808bits (3*DL RLC SDU)

Note: The UL RLC SDU size for each test case is defined based on the asymmetrical DL/UL data rates transmitted within the test case

C.12 DL reference parameters for MBMS tests

This annex specifies the reference channel parameters for MBMS test cases.

C.12.1 MTCH

The parameters for the MTCH demodulation tests are specified in Table C.12.1.1 and Table C.12.1.2.

Table C.12.1.1: Physical channel parameters for S-CCPCH

Parameter	Unit	Level	Level
User Data Rate	kbps	256	128
Channel bit rate	kbps	960	480
Channel symbol rate	ksps	480	240
Slot Format #i	-	14	12
TFCI	-	ON	ON
Power offsets of TFCI and Pilot fields relative to data field	dB	0	0

Table C.12.1.2: Transport channel parameters for S-CCPCH

Parameter User Data Rate	MTCH		
	256 kbps	128 kbps 40 ms TTI	128 kbps, 80 ms TTI
Transport Channel Number	1	1	1
Transport Block Size	2560	2560	2560
Transport Block Set Size	10240	5120	10240
Nr of transport blocks/TTI	4	2	4
RLC SDU block size	10160	5072	10160
Transmission Time Interval	40 ms	40 ms	80 ms
Type of Error Protection	Turbo	Turbo	Turbo
Rate Matching attribute	256	256	256
Size of CRC	16	16	16
Position of TrCH in radio frame	Flexible	Flexible	Flexible

C.12.2 Combined MTCH demodulation and cell identification

The parameters for combined MTCH demodulation and cell identification test are defined in Table C.12.2.1.

Table C.12.2.1: Cell reselection parameters

Parameter	Unit	Value
Serving cell in the initial condition		Cell1
Neighbour cells		32 intra-frequency neighbour cells are indicated including Cell2 and Cell3
Cell_selection_and_reselection_quality_measure		CPICH E_c/N_0
Qqualmin	dB	-20
Qrxlevmin	dBm	-115
UE_TXPWR_MAX_RACH	dB	21
Qhyst2	dB	20 dB
Treselection	seconds	4
Sintrasearch	dB	not sent
IE "FACH Measurement occasion info"		not sent

Annex D (normative): Propagation Conditions

D.1 General

D.1.1 Definition of Additive White Gaussian Noise (AWGN) Interferer

The minimum bandwidth of the AWGN interferer shall be 1,5 times chip rate of the radio access mode (e.g. 5,76 MHz for a chip rate of 3,84 Mcps). The flatness across this minimum bandwidth shall be less than $\pm 0,5$ dB and the peak to average ratio at a probability of 0,001 % shall exceed 10 dB.

D.2 Propagation Conditions

D.2.1 Static propagation condition

The propagation for the static performance measurement is an Additive White Gaussian Noise (AWGN) environment. No fading and multi-paths exist for this propagation model.

D.2.2 Multi-path fading propagation conditions

Table D.2.2.1 shows propagation conditions that are used for the performance measurements in multi-path fading environment. All taps have classical Doppler spectrum.

Table D.2.2.1: Propagation conditions for multi-path fading environments

Case 1		Case 2		Case 3		Case 4		Case 5 (Note 1)		Case 6	
Speed for Band I, II, III, IV, IX and X: 3 km/h		Speed for Band I, II, III, IV, IX and X: 3 km/h		Speed for Band I, II, III, IV, IX and X: 120 km/h		Speed for Band I, II, III, IV, IX and X: 3 km/h		Speed for Band I, II, III, IV, IX and X: 50 km/h		Speed for Band I, II, III, IV, IX and X: 250 km/h	
Speed for Band V, VI and VIII: 7 km/h		Speed for Band V, VI and VIII: 7 km/h		Speed for Band V, VI and VIII: 282 km/h (Note 2)		Speed for Band V, VI and VIII: 7 km/h		Speed for Band V, VI and VIII: 118 km/h		Speed for Band V, VI and VIII: 583 km/h (Note 2)	
Speed for Band VII: 2.3 km/h		Speed for Band VII: 2.3 km/h		Speed for Band VII: 92 km/h		Speed for Band VII: 2.3 km/h		Speed for Band VII: 38 km/h		Speed for Band VII: 192 km/h	
Speed for Band XI: 4.1 km/h		Speed for Band XI: 4.1 km/h		Speed for Band XI: 166 km/h		Speed for Band XI: 4.1 km/h		Speed for Band XI: 69 km/h		Speed for Band XI: 345 km/h (Note 2)	
Relative Delay [ns]	Relative mean Power [dB]	Relative Delay [ns]	Relative mean Power [dB]	Relative Delay [ns]	Relative mean Power [dB]	Relative Delay [ns]	Relative mean Power [dB]	Relative Delay [ns]	Relative mean Power [dB]	Relative Delay [ns]	Relative mean Power [dB]
0	0	0	0	0	0	0	0	0	0	0	0
976	-10	976	0	260	-3	976	0	976	-10	260	-3
		20000	0	521	-6					521	-6
				781	-9					781	-9

NOTE 1: Case 5 is only used in Requirements for support of RRM.

NOTE 2: Speed above 250km/h is applicable to demodulation performance requirements only.

Table D.2.2.1A shows propagation conditions that are used for HSDPA performance measurements in multi-path fading environment.

Table D.2.2.1A: Propagation Conditions for multi-path fading environments for HSDPA

ITU Pedestrian A Speed 3km/h (PA3)		ITU Pedestrian B Speed 3km/h (PB3)		ITU vehicular A Speed 30km/h (VA30)		ITU vehicular A Speed 120km/h (VA120)	
Speed for Band I, II, III, IV, IX and X 3 km/h		Speed for Band I, II, III, IV, IX and X: 3 km/h		Speed for Band I, II, III, IV, IX and X: 30 km/h		Speed for Band I, II, III, IV, IX and X: 120 km/h	
Speed for Band V, VI, VIII 7 km/h		Speed for Band V, VI, VIII 7 km/h		Speed for Band V, VI, VIII 71 km/h		Speed for Band V, VI, VIII 282 km/h (Note 1)	
Speed for Band VII 2.3 km/h		Speed for Band VII 2.3 km/h		Speed for Band VII 23 km/h		Speed for Band VII 92 km/h	
Speed for Band XI 4.1 km/h		Speed for Band XI 4.1 km/h		Speed for Band XI 41 km/h		Speed for Band XI 166 km/h (Note 1)	
Relative Delay [ns]	Relative Mean Power [dB]	Relative Delay [ns]	Relative Mean Power [dB]	Relative Delay [ns]	Relative Mean Power [dB]	Relative Delay [ns]	Relative Mean Power [dB]
0	0	0	0	0	0	0	0
110	-9.7	200	-0.9	310	-1.0	310	-1.0
190	-19.2	800	-4.9	710	-9.0	710	-9.0
410	-22.8	1200	-8.0	1090	-10.0	1090	-10.0
		2300	-7.8	1730	-15.0	1730	-15.0
		3700	-23.9	2510	-20.0	2510	-20.0

NOTE 1: Speed above 120km/h is applicable to demodulation performance requirements only.

Table D.2.2.1B shows propagation conditions that are used for CQI test in multi-path fading

Table D.2.2.1B: Propagation Conditions for CQI test in multi-path fading

Case 8	
Speed for Band I, II, III, IV, IX and X: 30km/h	
Speed for Band V, VI and VIII: 71km/h	
Speed for Band VII: 23km/h	
Speed for Band XI: 41km/h	
Relative Delay [ns]	Relative mean Power [dB]
0	0
976	-10

Table D.2.2.1C shows propagation conditions that are used for MBMS demodulation performance measurements in multi-path fading environment.

Table D.2.2.1C: Propagation Conditions for Multi-Path Fading Environments for MBMS Performance Requirements

ITU vehicular A Speed 3km/h (VA 3)	
Speed for Band I, II, III, IV, IX and X 3 km/h	
Speed for Band V, VI and VIII 7 km/h	
Speed for Band VII: 2.3 km/h	
Speed for Band XI: 4.1 km/h	
Relative Delay [ns]	Relative Mean Power [dB]
0	0
310	-1.0
710	-9.0
1090	-10.0
1730	-15.0
2510	-20.0

D.2.3 Moving propagation conditions

The dynamic propagation conditions for the test of the baseband performance are non fading channel models with two taps. The moving propagation condition has two taps, one static, Path0, and one moving, Path1. The time difference between the two paths is according Equation D.2.3.1. The taps have equal strengths and equal phases.

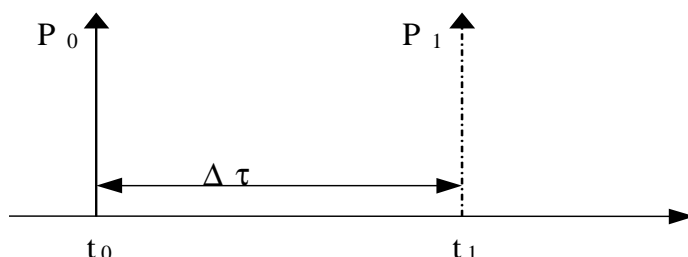

Figure D.2.3.1: The moving propagation conditions

$$\Delta\tau = B + \frac{A}{2}(1 + \sin(\Delta\omega \cdot t)) \tag{Equation D.2.3.1}$$

The parameters in the equation are shown in.

A	5 μs
B	1 μs
Δω	40 · 10 ⁻³ s ⁻¹

D.2.4 Birth-Death propagation conditions

The dynamic propagation conditions for the test of the baseband performance is a non fading propagation channel with two taps. The moving propagation condition has two taps, Path1 and Path2 while alternate between 'birth' and 'death'. The positions the paths appear are randomly selected with an equal probability rate and are shown in figure D.2.4.1.

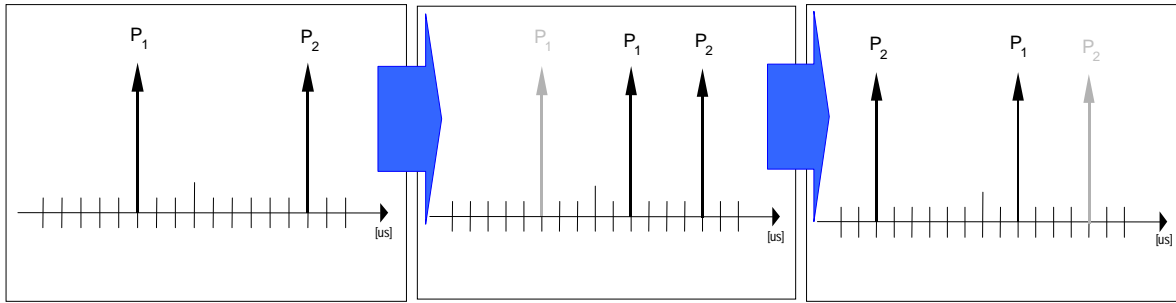

Figure D.2.4.1: Birth death propagation sequence

NOTE1: Two paths, Path1 and Path2 are randomly selected from the group [-5, -4, -3, -2, -1, 0, 1, 2, 3, 4, 5] μ s. The paths have equal strengths and equal phases.

NOTE 2: After 191 ms, Path1 vanishes and reappears immediately at a new location randomly selected from the group [-5, -4, -3, -2, -1, 0, 1, 2, 3, 4, 5] μ s but excludes the point Path2.

NOTE 3: After additional 191 ms, Path2 vanishes and reappears immediately at a new location randomly selected from the group [-5, -4, -3, -2, -1, 0, 1, 2, 3, 4, 5] μ s but excludes the point Path1.

NOTE 4: The sequence in 2) and 3) is repeated.

D.2.4A High speed train conditions

The high speed train condition for the test of the baseband performance is a non fading propagation channel with one tap. Doppler shift is given by

$$f_s(t) = f_d \cos \theta(t) \tag{D.2.4A.1}$$

where $f_s(t)$ is the Doppler shift and f_d is the maximum Doppler frequency. The cosine of angle $\theta(t)$ is given by

$$\cos \theta(t) = \frac{D_s/2 - vt}{\sqrt{D_{\min}^2 + (D_s/2 - vt)^2}}, \quad 0 \leq t \leq D_s/v \tag{D.2.4A.2}$$

where $D_s/2$ is the initial distance of the train from BS, and D_{\min} is BS-Railway track distance, both in meters; v is the velocity of the train in m/s, t is time in seconds. The parameters in the equation are shown in table D.2.4A.1. Accordingly, Doppler shift changes to the following figure D.2.4A.1.

Table D.2.4A.1

Parameter	Value
D_s	300 m
D_{\min}	2 m
v	300 km/h
f_d	600 Hz

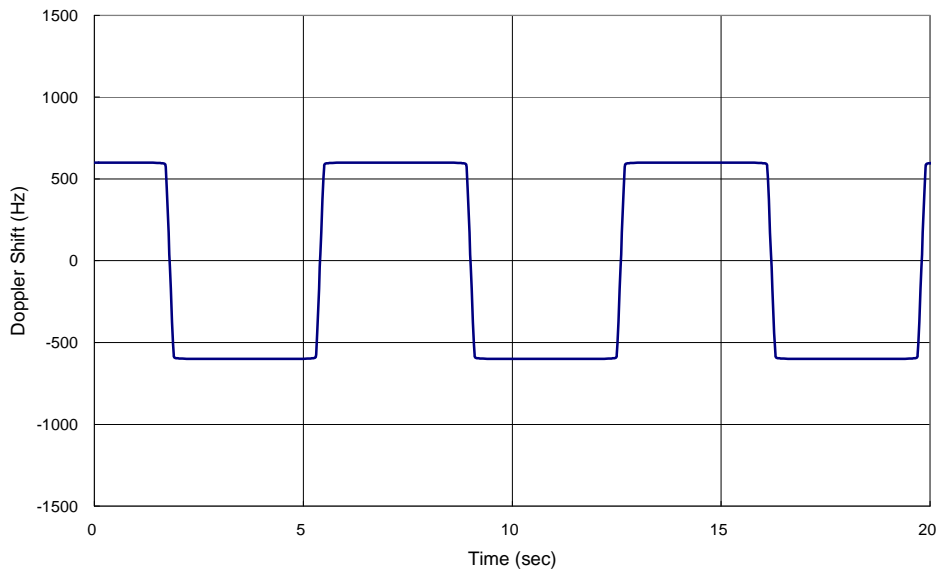

Figure D.2.4A.1: Doppler shift trajectory

D.2.5 Conditions for HSDPA enhanced performance requirements type 1 with UE receiver diversity

The fading profiles used in the two or four faders for testing enhanced performance requirements type 1 with UE receiver diversity shall be uncorrelated to each other.

The two AWGN signals used for testing enhanced performance requirements type 1 with UE receiver diversity shall be uncorrelated to each other.

D.2.6 Conditions for HSDPA enhanced performance requirements type 3 with UE receiver diversity

The fading profiles used in the two faders for testing enhanced performance requirements type 3 with UE receiver diversity shall be uncorrelated to each other.

The two AWGN signals used for testing enhanced performance requirements type 3 with UE receiver diversity shall be uncorrelated to each other.

D.2.7 Conditions for open and closed loop diversity performance

The fading profiles used in the two or four faders for testing open and closed loop diversity performance shall be uncorrelated to each other.

Annex E (normative): Downlink Physical Channels

E.1 General

This normative annex specifies the downlink physical channels that are needed for setting a connection and channels that are needed during a connection. For the definition of OCNS, the power of OCNS shall be controlled so as to keep the total transmit power spectral density I_{or} constant. The I_{or} shall be measured as the mean power defined in 3.1 Definitions. The mean power shall be kept constant from one slot to the next.

In test cases where the I_{or} should be kept constant, it shall be acceptable to continuously send logical channel DCCH data which is allowed to be dummy DCCH data, so that it is not necessary to count the number of power off symbols and calculate OCNS power every symbol or slot period to keep the I_{or} constant.

NOTE: The power level specified for each physical channel in this annex is an average power, as measured during periods when the physical channel transmission is ON (see [19] for definitions), and no DTX symbols are being transmitted on that physical channel.

E.2 Connection Set-up for non-HSDPA test cases

Table E.2.1 describes the downlink Physical Channels that are required for connection set up.

Table E.2.1: Downlink Physical Channels required for connection set-up

Physical Channel
CPICH
P-CCPCH
SCH
S-CCPCH
PICH
AICH
DPCH

E.2.1 Measurement without dedicated connection

Table E.2.2 describes the downlink Physical Channels that are required for measurement before connection. This is applicable for the clauses 5.4.1 and 5.5.2.

Table E.2.2: Downlink Physical Channels transmitted without dedicated connection

Physical Channel	Power
\hat{I}_{or}	Test dependent power
CPICH	$CPICH_Ec / I_{or} = -3.9$ dB
P-CCPCH	$P-CCPCH_Ec / I_{or} = -8.3$ dB
SCH	$SCH_Ec / I_{or} = -8.3$ dB
PICH	$PICH_Ec / I_{or} = -8.3$ dB
S-CCPCH	$S-CCPCH_Ec / I_{or} = -5.3$ dB

E.3 During connection for non-HSDPA test cases

The following clauses describe the downlink Physical Channels that are transmitted during a connection i.e., when measurements are done. For these measurements the offset between DPCH and SCH shall be zero chips at base station meaning that SCH is overlapping with the first symbols in DPCH in the beginning of DPCH slot structure.

E.3.1 Measurement of Tx Characteristics

Table E.3.1 is applicable for measurements on the Transmitter Characteristics (clause 5) with the exception of clauses 5.3, 5.4.1, 5.4.4 and 5.5.2.

NOTE: Applicability to clause 5.7 (Power setting in uplink compressed mode) is FFS.

Table E.3.1: Downlink Physical Channels transmitted during a connection

Physical Channel	Power
lor	-93 dBm / 3,84MHz
CPICH	CPICH_Ec / DPCH_Ec = 7 dB
P-CCPCH	P-CCPCH_Ec / DPCH_Ec = 5 dB
SCH	SCH_Ec / DPCH_Ec = 5 dB
PICH	PICH_Ec / DPCH_Ec = 2 dB
DPCH	-103,3 dBm / 3,84MHz

E.3.2 Measurement of Rx Characteristics

Table E.3.2.1 is applicable for measurements on the Receiver Characteristics (clause 6) including clauses 5.3, excluding clauses 6.3 and 6.8.

Table E.3.2.1: Downlink Physical Channels transmitted during a connection

Physical Channel	Power
CPICH	CPICH_Ec / DPCH_Ec = 7 dB
P-CCPCH	P-CCPCH_Ec / DPCH_Ec = 5 dB
SCH	SCH_Ec / DPCH_Ec = 5 dB
PICH	PICH_Ec / DPCH_Ec = 2 dB
DPCH	Test dependent power

Table E.3.2.2 describes the downlink Physical Channels that are required for the test of Spurious Emissions (clause 6.8). The UE is in the CELL_FACH state during the measurement.

Table E.3.2.2: Downlink Physical Channels transmitted during the Rx Spurious Emissions test

Physical Channel	Power
CPICH	-86dBm / 3,84MHz
P-CCPCH	P-CCPCH_Ec / CPICH_Ec = -2 dB
SCH	SCH_Ec / CPICH_Ec = -2 dB
PICH	PICH_Ec / CPICH_Ec = -5 dB
S-CCPCH	S-CCPCH_Ec / CPICH_Ec = -2 dB

E.3.3 Measurement of Performance requirements

Table E.3.3 is applicable for measurements on the Performance requirements (clause 7), including clauses 6.3 and 5.4.4, excluding clauses 7.6.1, 7.6.2, 7.11 and 7.12.

Table E.3.3.1 is applicable for measurements on the Performance requirements (clause 7) that are done without a dedicated connection (i.e. clauses 7.11 and 7.12).

Table E.3.3: Downlink Physical Channels transmitted during a connection

Physical Channel	Power ²	Note
P-CPICH	P-CPICH_Ec/Ior = -10 dB	Use of P-CPICH or S-CPICH as phase reference is specified for each requirement and is also set by higher layer signalling.
S-CPICH	S-CPICH_Ec/Ior = -10 dB	When S-CPICH is the phase reference in a test condition, the phase of S-CPICH shall be 180 degrees offset from the phase of P-CPICH. When S-CPICH is not the phase reference, it is not transmitted.
P-CCPCH	P-CCPCH_Ec/Ior = -12 dB	
SCH	SCH_Ec/Ior = -12 dB	This power shall be divided equally between Primary and Secondary Synchronous channels
PICH	PICH_Ec/Ior = -15 dB	
DPCH	Test dependent power	When S-CPICH is the phase reference in a test condition, the phase of DPCH shall be 180 degrees offset from the phase of P-CPICH.
OCNS	Necessary power so that total transmit power spectral density of Node B (Ior) adds to one ¹	OCNS interference consists of 16 dedicated data channels as specified in table E.3.6.
NOTE 1: For dynamic power correction required to compensate for the presence of transient channels, e.g. control channels, a subset of the OCNS DPCH channels may be used.		
NOTE 2: Power levels are based on the assumption that multipath propagation conditions and noise source representing interference from other cells loc are turned on after the call-set-up phase.		

Table E.3.3.1: Downlink Physical Channels transmitted without a dedicated connection

Physical Channel	Power ²	Note
P-CPICH	P-CPICH_Ec/Ior = -10 dB	
P-CCPCH	P-CCPCH_Ec/Ior = -12 dB	
S-CCPCH	S-CCPCH_Ec/Ior = -12 dB	This value is set in case the SCCPCH is not a test dependent power
SCH	SCH_Ec/Ior = -12 dB	This power shall be divided equally between Primary and Secondary Synchronous channels
PICH	PICH_Ec/Ior = -15 dB	This value is set in case the PICH is not a test dependent power
AICH	AICH_Ec/Ior = -10 dB	This value is set in case the AICH is not a test dependent power
OCNS	Necessary power so that total transmit power spectral density of Node B (Ior) adds to one ¹	OCNS interference consists of 16 dedicated data channels as specified in table E.3.6.
NOTE 1: For dynamic power correction required to compensate for the presence of transient channels, e.g. control channels, a subset of the OCNS DPCH channels may be used.		
NOTE 2: Power levels are based on the assumption that multipath propagation conditions and noise source representing interference from other cells loc are turned on after the call-set-up phase.		

E.3.4 Connection with open-loop transmit diversity mode

Table E.3.4 is applicable for measurements for clause 7.6.1.

Table E.3.4: Downlink Physical Channels transmitted during a connection

Physical Channel	Power ²	Note
P-CPICH (antenna 1)	$P\text{-CPICH_}E_{c1}/I_{or} = -13 \text{ dB}$	1. Total P-CPICH_ $E_c/I_{or} = -10 \text{ dB}$
P-CPICH (antenna 2)	$P\text{-CPICH_}E_{c2}/I_{or} = -13 \text{ dB}$	
P-CCPCH (antenna 1)	$P\text{-CCPCH_}E_{c1}/I_{or} = -15 \text{ dB}$	1. STTD applied 2. Total P-CCPCH_ $E_c/I_{or} = -12 \text{ dB}$
P-CCPCH (antenna 2)	$P\text{-CCPCH_}E_{c2}/I_{or} = -15 \text{ dB}$	
SCH (antenna 1 / 2)	$SCH_E_c/I_{or} = -12 \text{ dB}$	1. TSTD applied. 2. This power shall be divided equally between Primary and Secondary Synchronous channels
PICH (antenna 1)	$PICH_E_{c1}/I_{or} = -18 \text{ dB}$	1. STTD applied 2. Total PICH_ $E_c/I_{or} = -15 \text{ dB}$
PICH (antenna 2)	$PICH_E_{c2}/I_{or} = -18 \text{ dB}$	
DPCH	Test dependent power	1. STTD applied 2. Total power from both antennas
OCNS	Necessary power so that total transmit power spectral density of Node B (I_{or}) adds to one ¹	1. This power shall be divided equally between antennas 2. OCNS interference consists of 16 dedicated data channels as specified in Table E.3.6.
NOTE 1: For dynamic power correction required to compensate for the presence of transient channels, e.g. control channels, a subset of the OCNS DPCH channels may be used.		
NOTE 2: Power levels are based on the assumption that multipath propagation conditions and noise source representing interference from other cells loc are turned on after the call-set-up phase.		
NOTE 3: The time alignment of the P-CPICH from Antenna 1 and Antenna 2 as measured at the UE antenna connection shall be within 1/4 chip.		

E.3.5 Connection with closed loop transmit diversity mode

table E.3.5 is applicable for measurements for clause 7.6.2.

Table E.3.5: Downlink Physical Channels transmitted during a connection

Physical Channel	Power ²	Note
P-CPICH (antenna 1)	P-CPICH_Ec1/Ior = -13 dB	1. Total P-CPICH_Ec/Ior = -10 dB
P-CPICH (antenna 2)	P-CPICH_Ec2/Ior = -13 dB	
P-CCPCH (antenna 1)	P-CCPCH_Ec1/Ior = -15 dB	1. STTD applied
P-CCPCH (antenna 2)	P-CCPCH_Ec2/Ior = -15 dB	1. STTD applied, total P-CCPCH_Ec/Ior = -12 dB
SCH (antenna 1 / 2)	SCH_Ec/Ior = -12 dB	1. TSTD applied
PICH (antenna 1)	PICH_Ec1/Ior = -18 dB	1. STTD applied
PICH (antenna 2)	PICH_Ec2/Ior = -18 dB	2. STTD applied, total PICH_Ec/Ior = -15 dB
DPCH	Test dependent power	1. Total power from both antennas
OCNS	Necessary power so that total transmit power spectral density of Node B (Ior) adds to one ^{1,3}	1. This power shall be divided equally between antennas 2. OCNS interference consists of 16 dedicated data channels as specified in Table E.3.6.
NOTE 1: For dynamic power correction required to compensate for the presence of transient channels, e.g. control channels, a subset of the OCNS DPCH channels may be used.		
NOTE 2: Power levels are based on the assumption that multipath propagation conditions and noise source representing interference from other cells Ior are turned on after the call-set-up phase.		
NOTE 3: For the case of DPCH with transmit diversity, the OCNS power calculation shall be based on the addition of the power from Antenna 1 and Antenna 2, i.e. disregarding any phase relationship between the antennas.		
NOTE 4: The time alignment of the P-CPICH from Antenna 1 and Antenna 2 as measured at the UE antenna connection shall be within 1/4 chip.		

E.3.6 OCNS Definition

Table E.3.6: DPCH Channelization Code and relative level settings for OCNS signal.

Channelization Code at SF=128 ¹	Relative Level setting (dB) ^{1,2}	DPCH Data
2	-1	The DPCH data for each channelization code shall be uncorrelated with each other and with any wanted signal over the period of any measurement. For OCNS with transmit diversity the DPCH data sent to each antenna shall be either STTD encoded or generated from uncorrelated sources.
11	-3	
17	-3	
23	-5	
31	-2	
38	-4	
47	-8	
55	-7	
62	-4	
69	-6	
78	-5	
85	-9	
94	-10	
125	-8	
113	-6	
119	0	

NOTE 1: The DPCH Channelization Codes and relative level settings are chosen to simulate a signal with realistic Peak to Average Ratio.

NOTE 2: The relative level setting specified in dB refers only to the relationship between the OCNS channels. The level of the OCNS channels relative to the Ior of the complete signal is a function of the power of the other channels in the signal with the intention that the power of the group of OCNS channels is used to make the total signal add up to 1.

E.4 W-CDMA Modulated Interferer for non-HSDPA test cases

The W-CDMA modulated interferer consists of the downlink channels defined in table E.4.1 plus the OCNS channels defined in Table E.3.6. The relative power of the OCNS channels shall be such that the power of the total signal adds up to one. In this subclause I_{or} refers to the power of the interferer.

Table E.4.1: Spreading Code, Timing offsets and relative level settings for W-CDMA Modulated Interferer signal channels.

Channel Type	Spreading Factor	Channelization Code	Timing offset ($\times 256T_{\text{chip}}$)	Power	NOTE
P-CCPCH	256	1	0	$P\text{-CCPCH_Ec/lor} = -10 \text{ dB}$	
SCH	256	-	0	$SCH_Ec/lor = -10 \text{ dB}$	The SCH power shall be divided equally between Primary and Secondary Synchronous channels
P-CPICH	256	0	0	$P\text{-CPICH_Ec/lor} = *10 \text{ dB}$	
PICH	256	16	16	$PICH_Ec/lor = -15 \text{ dB}$	
OCNS	See table E.3.6			Necessary power so that total transmit power spectral density of Node B (I_{or}) adds to one	OCNS interference consists of the dedicated data channels. as specified in Table E.3.6.

E.5 HSDPA DL Physical channels

E.5.0 Downlink Physical Channels for connection set-up

Table E.5.0: Levels for HSDPA connection setup

Parameter During Connection setup	Unit	Value
P-CPICH_Ec/lor	dB	-10
P-CCPCH and SCH_Ec/lor	dB	-12
PICH_Ec/lor	dB	-15
HS-PDSCH	dB	off
HS-SCCH_1	dB	off
DPCH_Ec/lor	dB	-5
OCNS_Ec/lor	dB	-3.1

E.5.1 Downlink Physical Channels for measurement

Table E.5.1 is applicable for the measurements for tests in subclauses 5.2A, 5.2AA, 5.2C, 5.7A, 5.9A, 5.10A, 5.13.1A, 5.13.1AA, 5.13.2A, 6.3A, 9.2.1A to 9.2.1G, 9.3.1 and 9.3.2. Table E.5.2 is applicable for the measurements for tests in subclauses 9.2.2A to 9.2.2D, 9.3.3 and 9.3.4. Table E.5.3 is applicable for the measurements for tests in subclauses 9.2.3A to 9.2.3D, 9.3.5 and 9.3.6. Table E.5.4 is applicable for the measurements for tests in subclauses 9.4.1, 9.4.1A. Table E.5.4A is applicable for the measurements for tests in subclauses 9.4.2, 9.4.2A.

Table E.5.1: Downlink physical channels for HSDPA receiver testing for Single Link performance

Physical Channel	Parameter	Value	Note
P-CPICH	P-CPICH_Ec/Ior	-10dB	
P-CCPCH	P-CCPCH_Ec/Ior	-12dB	Mean power level is shared with SCH.
SCH	SCH_Ec/Ior	-12dB	Mean power level is shared with P-CCPCH – SCH includes P- and S-SCH, with power split between both. P-SCH code is S_dl,0 as per [14] S-SCH pattern is scrambling code group 0
PICH	PICH_Ec/Ior	-15dB	
DPCH	DPCH_Ec/Ior	Test-specific	12.2 kbps DL reference measurement channel as defined in Annex C.3.1
HS-SCCH-1	HS-SCCH_Ec/Ior	Test-specific	Specifies fraction of Node-B radiated power transmitted when TTI is active (i.e. due to minimum inter-TTI interval). During TTIs, in which the HS-SCCH is not allocated to the UE the HS-SCCH shall be transmitted continuously with constant power.
HS-SCCH-2	HS-SCCH_Ec/Ior	DTX'd	No signalling scheduled, or power radiated, on this HS-SCCH, but signalled to the UE as present.
HS-SCCH-3	HS-SCCH_Ec/Ior	DTX'd	As HS-SCCH-2.
HS-SCCH-4	HS-SCCH_Ec/Ior	DTX'd	As HS-SCCH-2.
HS-PDSCH	HS-PDSCH_Ec/Ior	Test-specific	.
OCNS		Necessary power so that total transmit power spectral density of Node B (Ior) adds to one ¹	OCNS interference consists of 6 dedicated data channels as specified in table E.5.5
NOTE 1: For dynamic power correction required to compensate for the presence of transient channels, e.g. control channels, a subset of the OCNS DPCH channels may be used.			

Table E.5.2: Downlink physical channels for HSDPA receiver testing for Open Loop Transmit Diversity performance.

Physical Channel	Parameter	Value	Note
P-CPICH (antenna 1)	P-CPICH_Ec1/lor	-13dB	1. Total P-CPICH_Ec/lor = -10dB
P-CPICH (antenna 2)	P-CPICH_Ec2/lor	-13dB	
P-CCPCH (antenna 1)	P-CCPCH_Ec1/lor	-15dB	1. STTD applied. 2. Total P-CCPCH Ec/lor is -12dB.
P-CCPCH (antenna 2)	P-CCPCH_Ec2/lor	-15dB	
SCH (antenna 1/2)	SCH_Ec/lor	-12dB	1. TSTD applied. 2. Power divided equally between primary and secondary SCH.
PICH (antenna 1)	PICH_Ec1/lor	-18dB	1. STTD applied. 2. Total PICH Ec/lor is -15dB.
PICH (antenna 2)	PICH_Ec2/lor	-18dB	
DPCH	DPCH_Ec/lor	Test-specific	1. STTD applied. 2. Total power from both antennas
HS-SCCH-1	HS-SCCH_Ec/lor	Test-specific	1. STTD applied. 2. Specifies fraction of Node-B radiated power transmitted when TTI is active (i.e. due to minimum inter-TTI interval). During TTIs, in which the HS-SCCH_1 is not allocated to the UE, the HS-SCCH_1 shall be transmitted continuously with constant power.
HS-SCCH-2	HS-SCCH_Ec/lor	DTX'd	1. UE assumes STTD applied. 2. No signalling scheduled, or power radiated, on this HS-SCCH, but signalled to the UE as present.
HS-SCCH-3	HS-SCCH_Ec/lor	DTX'd	1. As HS-SCCH-2.
HS-SCCH-4	HS-SCCH_Ec/lor	DTX'd	2. As HS-SCCH-2.
HS-PDSCH	HS-PDSCH_Ec/lor	Test-specific	1. STTD applied. 2. Total power from both antennas
OCNS		Necessary power so that total transmit power spectral density of Node B (lor) adds to one ^{1,2}	1. Balance of power I_{or} of the Node-B is assigned to OCNS. 2. Power divided equally between antennas. 3. OCNS interference consists of 6 dedicated data channels as specified in table E.5.5.
NOTE 1: For dynamic power correction required to compensate for the presence of transient channels, e.g. control channels, a subset of the OCNS DPCH channels may be used.			
NOTE 2: For the case of DPCH with transmit diversity, the OCNS power calculation shall be based on the addition of the power from Antenna 1 and Antenna 2, i.e. disregarding any phase relationship between the antennas.			

Table E.5.3: Downlink physical channels for HSDPA receiver testing for Closed Loop Transmit Diversity (Mode-1) performance.

Physical Channel	Parameter	Value	Note
P-CPICH (antenna 1)	P-CPICH_Ec1/lor	-13dB	1. Total P-CPICH_Ec/lor = -10dB
P-CPICH (antenna 2)	P-CPICH_Ec2/lor	-13dB	
P-CCPCH (antenna 1)	P-CCPCH_Ec1/lor	-15dB	1. STTD applied. 2. Total P-CCPCH Ec/lor is -12dB.
P-CCPCH (antenna 2)	P-CCPCH_Ec2/lor	-15dB	
SCH (antenna 1/2)	SCH_Ec/lor	-12dB	1. TSTD applied. 2. Power divided equally between primary and secondary SCH.
PICH (antenna 1)	PICH_Ec1/lor	-18dB	1. STTD applied. 2. Total PICH Ec/lor is -15dB.
PICH (antenna 2)	PICH_Ec2/lor	-18dB	
DPCH	DPCH_Ec/lor	Test-specific	1. CL1 applied. 2. Total power from both antennas
HS-SCCH-1	HS-SCCH_Ec/lor	Test-specific	1. STTD applied. 2. Specifies fraction of Node-B radiated power transmitted when TTI is active (i.e. due to minimum inter-TTI interval). During TTIs, in which the HS-SCCH_1 is not allocated to the UE, the HS-SCCH_1 shall be transmitted continuously with constant power.
HS-SCCH-2	HS-SCCH_Ec/lor	DTX'd	1. UE assumes STTD applied. 2. No signalling scheduled, or power radiated, on this HS-SCCH, but signalled to the UE as present.
HS-SCCH-3	HS-SCCH_Ec/lor	DTX'd	1. As HS-SCCH-2.
HS-SCCH-4	HS-SCCH_Ec/lor	DTX'd	2. As HS-SCCH-2.
HS-PDSCH	HS-PDSCH_Ec/lor	Test-specific	1. CL1 applied. 2. Total power from both antennas
OCNS		Necessary power so that total transmit power spectral density of Node B (lor) adds to one ^{1,2}	1. Balance of power I_{or} of the Node-B is assigned to OCNS. 2. Power divided equally between antennas. 3. OCNS interference consists of 6 dedicated data channels as specified in table E.5.5.
NOTE 1: For dynamic power correction required to compensate for the presence of transient channels, e.g. control channels, a subset of the OCNS DPCH channels may be used.			
NOTE 2: For the case of DPCH with transmit diversity, the OCNS power calculation shall be based on the addition of the power from Antenna 1 and Antenna 2, i.e. disregarding any phase relationship between the antennas.			

Table E.5.4: Downlink physical channels for HSDPA receiver testing for HS-SCCH detection performance

Parameter	Units	Value	Comment
CPICH E_c/I_{or}	dB	-10	
CCPCH E_c/I_{or}	dB	-12	Mean power level is shared with SCH.
SCH E_c/I_{or}	dB	-12	Mean power level is shared with P-CCPCH – SCH includes P- and S-SCH, with power split between both. P-SCH code is S_dl,0 as per [14] S-SCH pattern is scrambling code group 0
PICH E_c/I_{or}	dB	-15	
HS-PDSCH-1 E_c/I_{or}	dB	-10	HS-PDSCH associated with HS-SCCH-1. The HS-PDSCH shall be transmitted continuously with constant power.
HS-PDSCH-2 E_c/I_{or}	dB	DTX	HS-PDSCH associated with HS-SCCH-2
HS-PDSCH-3 E_c/I_{or}	dB	DTX	HS-PDSCH associated with HS-SCCH-3
HS-PDSCH-4 E_c/I_{or}	dB	DTX	HS-PDSCH associated with HS-SCCH-4
DPCH E_c/I_{or}	dB	-8	12.2 kbps DL reference measurement channel as defined in Annex C.3.1
HS-SCCH-1 E_c/I_{or}	dB	Test Specific	All HS-SCCH's allocated equal E_c/I_{or} . Specifies E_c/I_{or} when TTI is active. During TTIs, in which the HS-SCCH's are not allocated to the UE, the HS-SCCH's shall be transmitted continuously with constant power.
HS-SCCH-2 E_c/I_{or}	dB		
HS-SCCH-3 E_c/I_{or}	dB		
HS-SCCH-4 E_c/I_{or}	dB		
OCNS E_c/I_{or}	dB	Remaining power at Node-B (including HS-SCCH power allocation when HS-SCCH's inactive). ^{1,2}	OCNS interference consists of 6 dedicated data channels as specified in table E.5.5
NOTE 1: For dynamic power correction required to compensate for the presence of transient channels, e.g. control channels, a subset of the OCNS DPCH channels may be used.			
NOTE 2: For the case of DPCH with transmit diversity, the OCNS power calculation shall be based on the addition of the power from Antenna 1 and Antenna 2, i.e. disregarding any phase relationship between the antennas.			

Table E.5.4A: Downlink physical channels for HSDPA receiver testing for HS-SCCH detection with Open Loop Transmit Diversity performance

Parameter	Units	Value	Comment
P-CPICH (antenna 1)	P-CPICH_Ec1/lor	-13dB	1. Total P-CPICH_Ec/lor = -10dB
P-CPICH (antenna 2)	P-CPICH_Ec2/lor	-13dB	
P-CCPCH (antenna 1)	P-CCPCH_Ec1/lor	-15dB	1. STTD applied. 2. Total P-CCPCH Ec/lor is -12dB.
P-CCPCH (antenna 2)	P-CCPCH_Ec2/lor	-15dB	
SCH (antenna 1/2)	SCH_Ec/lor	-12dB	1. TSTD applied. 2. Power divided equally between primary and secondary SCH.
PICH (antenna 1)	PICH_Ec1/lor	-18dB	1. STTD applied.
PICH (antenna 2)	PICH_Ec2/lor	-18dB	2. Total PICH Ec/lor is -15dB.
HS-PDSCH-1 E_c/I_{or}	dB	-10 dB	1. STTD applied. 2. HS-PDSCH associated with HS-SCCH-1. The HS-PDSCH shall be transmitted continuously with constant power. 3. Total power from both antennas
HS-PDSCH-2 E_c/I_{or}	dB	DTX	HS-PDSCH associated with HS-SCCH-2
HS-PDSCH-3 E_c/I_{or}	dB	DTX	HS-PDSCH associated with HS-SCCH-3
HS-PDSCH-4 E_c/I_{or}	dB	DTX	HS-PDSCH associated with HS-SCCH-4
DPCH E_c/I_{or}	dB	-8	1. STTD applied. 2. Total power from both antennas
HS-SCCH-1 E_c/I_{or}	dB	Test Specific	1. UE assumes STTD applied. 2. All HS-SCCH's allocated equal E_c/I_{or} . Specifies E_c/I_{or} when TTI is active. During TTIs, in which the HS-SCCH's are not allocated to the UE, the HS-SCCH's shall be transmitted continuously with constant power.
HS-SCCH-2 E_c/I_{or}	dB		
HS-SCCH-3 E_c/I_{or}	dB		
HS-SCCH-4 E_c/I_{or}	dB		
OCNS E_c/I_{or}	dB	Remaining power at Node-B (including HS-SCCH power allocation when HS-SCCH's inactive). ^{1,2}	OCNS interference consists of 6 dedicated data channels as specified in table E.5.5
NOTE 1: For dynamic power correction required to compensate for the presence of transient channels, e.g. control channels, a subset of the OCNS DPCH channels may be used.			
NOTE 2: For the case of DPCH with transmit diversity, the OCNS power calculation shall be based on the addition of the power from Antenna 1 and Antenna 2, i.e. disregarding any phase relationship between the antennas.			

E.5.2 HSDPA OCNS Definition

The selected channelization codes and relative power levels for OCNS transmission for HSDPA performance assessment are defined in Table E.5.5. The selected codes are designed to have a single length-16 parent code.

Table E.5.5: OCNS definition for HSDPA receiver testing

Channelization Code at SF=128	Relative Level setting (dB)	DPCH Data
122	0	The DPCH data for each channelization code shall be uncorrelated with each other and with any wanted signal over the period of any measurement. For OCNS with transmit diversity the DPCH data sent to each antenna shall be either STTD encoded or generated from uncorrelated sources.
123	-2	
124	-2	
125	-4	
126	-1	
127	-3	

NOTE 1: The relative level setting specified in dB refers only to the relationship between the OCNS channels. The level of the OCNS channels relative to the Ior of the complete signal is a function of the power of the other channels in the signal with the intention that the power of the group of OCNS channels is used to make the total signal add up to 1.

E.5.3 Downlink Physical Channels for measurement including test tolerances

Table E.5.6 to E.5.8B are applicable for tests in subclause 9.2. Table E.5.9 indicates which levels are applied, when the primary level settings (Ec/Ior and Ior/Ioc) and propagation conditions (PA3, PB3, VA30, VA 120) vary.

Table E.5.6: Level set 1 for HSDPA measurements including test tolerances

Parameter During Measurement	Unit	Value
P-CPICH_Ec/Ior	dB	-9.9
P-CCPCH and SCH_Ec/Ior	dB	-11.9
PICH_Ec/Ior	dB	-14.9
HS-PDSCH	dB	-5.9
HS-SCCH_1	dB	-7.4
DPCH_Ec/Ior	dB	-5
OCNS_Ec/Ior	dB	-13.3
Measurement conditions	PA3	HS-PDSCH = -6dB, Ior/Ioc = 0dB

Table E.5.7: Level set 2 for HSDPA measurements including test tolerances

Parameter During Measurement	Unit	Value
P-CPICH_Ec/Ior	dB	-9.9
P-CCPCH and SCH_Ec/Ior	dB	-11.9
PICH_Ec/Ior	dB	-14.9
HS-PDSCH	dB	-5.9
HS-SCCH_1	dB	-8.4
DPCH_Ec/Ior	dB	-5
OCNS_Ec/Ior	dB	-10.75
Measurement conditions		HS-PDSCH = -6dB, Ior/Ioc = 10dB and 0dB

Table E.5.8: Level set 3 for HSDPA measurements including test tolerances

Parameter During Measurement	Unit	Value
P-CPICH_Ec/Ior	dB	-9.9
P-CCPCH and SCH_Ec/Ior	dB	-11.9
PICH_Ec/Ior	dB	-14.9
HS-PDSCH	dB	-2.9
HS-SCCH_1	dB	-8.4
DPCH_Ec/Ior	dB	-8.4
OCNS_Ec/Ior	dB	off
Measurement conditions		HS-PDSCH = -3dB, Ior/Ioc = 10dB and 0 dB

Table E.5.8A: Level set 4 for HSDPA measurements including test tolerances

Parameter During Measurement	Unit	Value
P-CPICH_Ec/Ior	dB	-9.9
P-CCPCH and SCH_Ec/Ior	dB	-11.9
PICH_Ec/Ior	dB	-14.9
HS-PDSCH	dB	-8.9
HS-SCCH_1	dB	-8.4
DPCH_Ec/Ior	dB	-5
OCNS_Ec/Ior	dB	-6.75
Measurement conditions	HS-PDSCH = -9dB, Ior/Ioc = 10dB	

Table E.5.8B: Level set 5 for HSDPA measurements including test tolerances

Parameter During Measurement	Unit	Value
P-CPICH_Ec/Ior	dB	-9.9
P-CCPCH and SCH_Ec/Ior	dB	-11.9
PICH_Ec/Ior	dB	-14.9
HS-PDSCH	dB	-11.9
HS-SCCH_1	dB	-8.4
DPCH_Ec/Ior	dB	-5
OCNS_Ec/Ior	dB	-5.6
Measurement conditions	HS-PDSCH = -12dB, Ior/Ioc = 10dB	

Table E.5.9: Application of level sets for measurement

Test Number	Propagation Conditions	Reference value		
		HS-PDSCH E_c / I_{or} (dB)	T-put R (kbps) $\hat{I}_{or} / I_{oc} = 0$ dB	T-put R (kbps) $\hat{I}_{or} / I_{oc} = 10$ dB
1	PA3	-12	Not tested	Level set 5
		-9	Not tested	Level set 4
		-6	Level set 1	Level set 2
		-3	Level set 3	Level set 3
2	PB3	-9	Not tested	Level set 4
		-6	Level set 2	Level set 2
		-3	Level set 3	Level set 3
3	VA30	-9	Not tested	Level set 4
		-6	Level set 2	Level set 2
		-3	Level set 3	Level set 3
4	VA120	-9	Not tested	Level set 4
		-6	Level set 2	Level set 2
		-3	Level set 3	Level set 3

E.5.4 Downlink Physical Channels for Transmitter Characteristics with HS-DPCCH

Table E.5.10 is applicable for measurements on the Transmitter Characteristics with HSDPA in clauses 5.2A, 5.2AA, 5.2C, 5.7A, 5.9A, 5.10A, 5.13.1A, 5.13.1AA and 5.13.2A.

Table E.5.10: Test specific downlink physical channels

Parameter	Unit	Test
DPCH	DPCH_Ec/Ior (dB)	-9
HS-SCCH_1	HS-SCCH_Ec/Ior (dB)	-8
HS-PDSCH	HS-PDSCH_Ec/Ior (dB)	-3
Note:	The power levels are selected high enough to keep the DTX reporting ratio very small and to ensure that the radio link is maintained during the test.	

E.5A E-DCH with HSDPA DL Physical channels

E.5A.0 Downlink Physical Channels for connection set-up

Table E.5A.0: Levels for connection setup

Parameter During Connection setup	Unit	Value
P-CPICH_Ec/Ior	dB	-10
P-CCPCH and SCH_Ec/Ior	dB	-12
PICH_Ec/Ior	dB	-15
HS-PDSCH	dB	off
HS-SCCH_1	dB	off
DPCH_Ec/Ior	dB	-5
E-HICH	dB	off
E-AGCH	dB	off
E-RGCH	dB	off
OCNS_Ec/Ior	dB	-3.1

E.5A.1 Downlink Physical Channels for measurement

Table E.5A.1 is applicable for tests in subclause 5.2B, 5.2D, 5.9B, 5.10B, and 5.13.2B. Table E.5A.2 is applicable for tests in subclause 10.2.1, 10.3.1, 10.4.1. and 10.4.1A. Table E.5A.3 is applicable for tests in subclause 10.2.2, 10.3.2 and 10.3.2A.

Table E.5A.1: Downlink Physical Channel parameters for E-DCH the Transmitter Characteristics tests

Parameter During Measurement	Unit	Value	Remark
P-CPICH_Ec/Ior	dB	-10	
P-CCPCH and SCH_Ec/Ior	dB	-12	
PICH_Ec/Ior	dB	-15	
HS-PDSCH	dB	-3	During TTIs, in which the HS-PDSCH is not allocated to the UE via HS-SCCH signalling, the HS-PDSCH shall be transmitted continuously with constant power
HS-SCCH_1	dB	-8	During TTIs, in which the HS-SCCH is not allocated to the UE the HS-SCCH shall be transmitted continuously with constant power.
DPCH_Ec/Ior	dB	-10	
E-AGCH	dB	-20	
E-HICH	dB	-20	
E-RGCH	dB	DTX'd	
OCNS_Ec/Ior	dB	Necessary power so that total transmit power spectral density of Node B (Ior) adds to one	OCNS interference consists of 6 dedicated data channels as specified in table E.5A.4

NOTE 1: For dynamic power correction required to compensate for the presence of transient channels, e.g. control channels, a subset of the OCNS DPCH channels may be used.

NOTE 2: For 5.2B, 5.9B, 5.10B, the power levels are selected high enough to keep the DTX reporting ratio very small and to ensure that the radio link is maintained during the test.

Table E.5A.2: Downlink Physical Channel parameters for E-DCH singlelink performance tests

Parameter During Measurement	Unit	Value	Remark
P-CPICH_Ec/Ior	dB	-10	
P-CCPCH and SCH_Ec/Ior	dB	-12	
PICH_Ec/Ior	dB	-15	
HS-PDSCH	dB	-3	During TTIs, in which the HS-PDSCH is not allocated to the UE via HS-SCCH signalling, the HS-PDSCH shall be transmitted continuously with constant power
HS-SCCH_1	dB	-7.5	During TTIs, in which the HS-SCCH is not allocated to the UE the HS-SCCH shall be transmitted continuously with constant power.
DPCH_Ec/Ior	dB	-10	
E-AGCH	dB	Test specific	Test-specific value or -20dB is used
E-HICH	dB	Test specific	Test-specific value or DTX'd is used
E-RGCH	dB	Test specific	Test-specific value or DTX'd is used
OCNS_Ec/Ior	dB	Necessary power so that total transmit power spectral density of Node B (Ior) adds to one	OCNS interference consists of 6 dedicated data channels as specified in table E.5A.4

NOTE 1: For dynamic power correction required to compensate for the presence of transient channels, e.g. control channels, a subset of the OCNS DPCH channels may be used.

Table E.5A.3: Downlink Physical Channel parameters for E-DCH in Inter-cell SHO tests

Parameter During Measurement (Note 1)	Unit	Value	Remark
P-CPICH_Ec/Ior _{1 and 2}	dB	-10	
P-CCPCH and SCH_Ec/Ior _{1 and 2}	dB	-12	
PICH_Ec/Ior _{1 and 2}	dB	-15	
HS-PDSCH ₁	dB	Test specific	During TTIs, in which the HS-PDSCH is not allocated to the UE via HS-SCCH signalling, the HS-PDSCH shall be transmitted continuously with constant power
HS-SCCH _{1,1}	dB	-7.5	During TTIs, in which the HS-SCCH is not allocated to the UE the HS-SCCH shall be transmitted continuously with constant power.
DPCH_Ec/Ior _{1 and 2}	dB	-10	
E-AGCH ₁	dB	Test specific	Test-specific value or -20dB is used
E-HICH ₁	dB	Test specific	Test-specific value or DTX'd is used
E-RGCH ₁	dB	Test specific	Test-specific value or DTX'd is used
OCNS_Ec/Ior _{1 and 2}	dB	Necessary power so that total transmit power spectral density of Node B (Ior) adds to one).	OCNS interference consists of 6 dedicated data channels as specified in table E.5A.4
NOTE1: Index 1: cell belonging to RLS containing the Serving E-DCH cell, Index 2: cell belonging to RLS not containing the Serving E-DCH cell			

E.5A.2 E-DCH OCNS Definition

The selected channelization codes and relative power levels for OCNS transmission for E-DCH tests assessment are defined in Table E.5A.4. The selected codes are designed to have a single length-16 parent code.

Table E.5A.4: OCNS definition for HSDPA receiver testing

Channelization Code at SF=128	Relative Level setting (dB)	DPCH Data
122	0	The DPCH data for each channelization code shall be uncorrelated with each other and with any wanted signal over the period of any measurement. For OCNS with transmit diversity the DPCH data sent to each antenna shall be either STTD encoded or generated from uncorrelated sources.
123	-2	
124	-2	
125	-4	
126	-1	
127	-3	

NOTE 1: The relative level setting specified in dB refers only to the relationship between the OCNS channels. The level of the OCNS channels relative to the Ior of the complete signal is a function of the power of the other channels in the signal with the intention that the power of the group of OCNS channels is used to make the total signal add up to 1.

E.5B MBMS DL Physical channels

E.5B.1 Downlink Physical Channels for connection set-up

Table E.5B.1 is applicable for measurements on the Performance requirements in Clause 11.

Table E.5B.1: Downlink Physical Channels on each radiolink

Physical Channel	Power ratio	NOTE
P-CPICH	$P\text{-CPICH}_{Ec/Ior} = -10 \text{ dB}$	Only P-CPICH is used as phase reference for S-CCPCH carrying MCCH or MTCH.
P-CCPCH	$P\text{-CCPCH}_{Ec/Ior} = -12 \text{ dB}$	
SCH	$SCH_{Ec/Ior} = -12 \text{ dB}$	This power shall be divided equally between Primary and Secondary Synchronous channels
PICH	$PICH_{Ec/Ior} = -15 \text{ dB}$	
S-CCPCH	$S\text{-CCPCH}_{Ec/Ior} = \text{test dependent}$	
DPCH	TBD	DPCH is enable only when UE has capability to receive MBMS in CELL_DCH state
OCNS	Necessary power so that total transmit power spectral density of Node B (Ior) adds to one	OCNS interference consists of 16 dedicated data channels as specified in table E.3.6

E.6 Downlink Physical Channels Code Allocation (This clause is informative)

E.6.1 Downlink Physical Channels Code Allocation for non-HSDPA test cases

Table E.6.1.1 shows the downlink code allocation for non-HSDPA test cases. The numbers in the code columns indicate the code number with the respective spreading factor (SF). The Note column refers to specifications where the code allocation is defined. Only the system configuration according to TS 34.108 [3] section 6.10b is used for RF testing. The codes used for the WCDMA interferer as defined in Table E.4.1 are not included in the table below because the WCDMA interferer is on another carrier. The S-CCPCH has been moved from code 1 to code 2 (SF=64) in order to resolve the code conflict with OCNS DPCH.

Table E.6.1.1: Downlink Physical Channels Code Allocation for RF testing (non-HSDPA)

Code with SF=256	Code with SF=128	Code with SF=64	Note
0: P-CPICH	0: -	0: -	TS 25.213; TS 34.108 [3]: 6.1.4
1: P-CCPCH			TS 25.213
2: PICH	1: -		TS 34.108 [3]: 6.1.0b (SIB5)
3: AICH			TS 34.108 [3]: 6.1.0b (SIB5)
4: -	2: OCNS DPCH	1: -	OCNS: TS34.121: Table E.3.6
5: -			
6: -	3: S-CCPCH		3: TS 34.121: TC 7.11 (PCH) only
7: -			
8: -	4: -	2: S-CCPCH	S-CCPCH for RF testing TS 34.108 [3]: 7.3 (SIB5), TS 34.121: TC 7.11 (FACH)
9: -			
10: -	5: -		5: TS 34.108 [3]: 6.1.2 (CTCH)
11: -			
12: -	6: -	3: -	
13: -			
14: -	7: -	4: -	
15: -			
16: -	8: -	5: -	
17: -			
18: -	9: -	6: -	
19: -			
20: -	10: -	7: -	
21: -			
22: -	11: OCNS DPCH	8: -	
23: -			
24-31: -	12-15: -	9-10: -	OCNS: TS 34.121: E.3.6
32: -	16: -	11: -	
33: -			
34: -	17: OCNS DPCH	12: -	
35: -			
36-43: -	18-21: -	13: -	OCNS: TS 34.121: E.3.6
44: -	22: -	14: -	
45: -			
46: -	23: OCNS DPCH	15: -	
47: -			
48-59: -	24-29: -	16: -	
60: -	30: -	17: -	
61: -			
62: -	31: OCNS DPCH	18: -	
63: -			
64-75: -	32-37: -	19: -	OCNS: TS 34.121: E.3.6
76: -	38: OCNS DPCH	20: -	
77: -			
78: -	39: -	21: -	
79: -			

Code with SF=256	Code with SF=128	Code with SF=64	Note
80-91: -	40-45: -	20-22: -	
92: -	46: - 47: OCNS DPCH	23: -	OCNS: TS 34.121: E.3.6
93: -			
94: -			
95: -			
96-107: -	48-53: -	24-26: -	
108: -	54: - 55: OCNS DPCH	27: -	OCNS: TS 34.121: E.3.6
109: -			
110: -			
111: -	56-61: - 62: OCNS DPCH 63: - 64-67: - 68: -	28-30: - 31: - 32-33: - 34: -	OCNS: TS 34.121: E.3.6 OCNS: TS 34.121: E.3.6
112-123: -			
124: -			
125: -			
126: -			
127: -	69: OCNS DPCH	35-38: - 39: -	OCNS: TS 34.121: E.3.6
128-135: -			
136: -			
137: -			
138: -	70-77: - 78: OCNS DPCH 79: - 80-83: - 84: -	40-41: - 42: -	OCNS: TS 34.121: E.3.6
139: -			
140-155: -			
156: -			
157: -			
158: -	85: OCNS DPCH	43-46: - 47: - 48: -	OCNS: TS 34.121: E.3.6 OCNS: TS 34.121: E.3.6 TS 34.108 [3]: 9.2.1 (DCH SRB and 12.2); DCH 64: SF32-Code24, DCH 144: SF16-Code12, DCH 384: SF8-Code6
159: -			
160-167: -			
168: -			
169: -			
170: -	86-93: - 94: OCNS DPCH 95: - 96: DCH 12.2 97: -	49-55: - 56: -	OCNS: TS 34.121: E.3.6
171: -			
172-187: -			
188: -			
189: -			
190: -	98-111: - 112: - 113: OCNS DPCH	57-58: - 59: -	OCNS: TS 34.121: E.3.6
191: -			
192: DCH SRB			
193: -			
194: -			
195: -	114-117: - 118: - 119: OCNS DPCH	60-61: - 62: -	OCNS: TS 34.121: E.3.6
196-223: -			
224: -			
225: -			
226: -			
227: -	120-123: - 124: - 125: OCNS DPCH	63: -	OCNS: TS 34.121: E.3.6
228-235: -			
236: -			
237: -			
238: -			
239: -	126-127: -		
240-59: -			
248: -			
249: -			
250: -			
251: -			
252-255: -			

E.6.2 Downlink Physical Channels Code Allocation for HSDPA test cases

Tables E.6.2.1 and E.6.2.2 show the downlink code allocation for HSDPA test cases. Table E.6.2.1 shows the complete downlink code tree for spreading factors 16, 32 and 64. Table E.6.2.2 shows details of the downlink code tree for SF=16 code=0 with spreading factors 64, 128 and 256. The numbers in the code columns indicate the code number with the respective spreading factor (SF). The Note column refers to specifications where the code allocation is defined.

- Note 1: Performance requirements for test cases using 15 HS-PDSCH codes have not been defined by RAN4 yet. A specific code allocation for test cases using 15 HS-PDSCH codes needs to be aligned with assumptions taken in RAN4.

Table E.6.2.1: HSDPA Downlink Physical Channels Code Allocation for RF testing

Code with SF=64	Code with SF=32	Code with SF=16	Note
0: -	0: -	0: -	P-CPICH, P-CCPCH, PICH, AICH on SF256
1: -			HS-SCCH1 and HS-SCCH2 on SF128
2: S-CCPCH			S-CCPCH: TS 34.108 [3]: 6.1.0b
3: -	1: -	1: HS-PDSCH	HS-SCCH3 and HS-SCCH4 on SF128
4: -	2: -		1st HS-PDSCH code
5: -	3: -		
6: -			
7: -			
8: -			
9: -			
10: -	4: -	2: HS-PDSCH	2nd HS-PDSCH code
11: -	5: -		
12: -	6: -		
13: -	7: -	3: HS-PDSCH	3rd HS-PDSCH code
14: -			
15: -			
16: -	8: -	4: HS-PDSCH	4th HS-PDSCH code
17: -	9: -		
18: -			
19: -	10: -	5: HS-PDSCH	5th HS-PDSCH code
20: -	11: -		
21: -			
22: -			
23: -			
24: -	12: -	6: HS-PDSCH	6th HS-PDSCH code
25: -	13: -		
26: -			
27: -	14: -	7: HS-PDSCH	7th HS-PDSCH code
28: -	15: -		
29: -			
30: -			
31: -	16: -	8: HS-PDSCH	8th HS-PDSCH code
32: -	17: -		
33: -			
34: -			
35: -	18: -	9: HS-PDSCH	9th HS-PDSCH code
36: -	19: -		
37: -			
38: -			
39: -	20: -	10: HS-PDSCH	10th HS-PDSCH code
40: -	21: -		
41: -			
42: -	22: -	11: -	
43: -	23: -		
44: -			
45: -			
46: -			
47: -	24: -	12: -	RMC12.2 on code 96 (SF128), the SRB standalone used during call setup on code 192 (SF256) (TS 34.108 [3]: 9.2.1)
48: -	25: -		
49: -			
50: -	26: -	13: -	
51: -	27: -		
52: -			
53: -	28: -	14: -	
54: -	29: -		
55: -			
56: -	29: -		
57: -			
58: -			
59: -			

Code with SF=64	Code with SF=32	Code with SF=16	Note
60: -	30: -	15: -	OCNS DPCH on codes 122-127 (SF128)
61: -			
62: -	31: -		
63: -			

Table E.6.2.2: HSDPA Downlink Physical Channels Code Allocation for SF=16 code=0

Code with SF=256	Code with SF=128	Code with SF=64	Note
0: P-CPICH	0: -	0: -	TS 25.213; 34.108 [3]: 6.1.4; 34.121: E.4.2
1: P-CCPCH			TS 25.213; 34.121: E.4.2
2: PICH	1: -		TS 34.108 [3]: 6.1.0b (SIB5)
3: AICH			TS 34.108 [3]: 6.1.0b (SIB5)
4: -	2: HS-SCCH1	1: -	TS 34.108 [3]: 9.2.1 RB Setup message
5: -			
6: -	3: HS-SCCH2		TS 34.108 [3]: 9.2.1 RB Setup message
7: -			
8: -	4: -	2: S-CCPCH	S-CCPCH: TS 34.108 [3]: 6.1.0b (SIB5)
9: -			
10: -	5: -		
11: -			
12: -	6: HS-SCCH3	3: -	TS 34.108 [3]: 9.2.1 RB Setup message
13: -			
14: -	7: HS-SCCH4		TS 34.108 [3]: 9.2.1 RB Setup message
15: -			

E.6.3 Downlink Physical Channels Code Allocation for E-DCH test cases

Tables E.6.3.1 and E.6.3.2 show the downlink code allocation for E-DCH test cases. Table E.6.3.1 shows the complete downlink code tree for spreading factors 16, 32 and 64. Table E.6.3.2 shows details of the downlink code tree for SF=16 code=0 with spreading factors 64, 128 and 256. The numbers in the code columns indicate the code number with the respective spreading factor (SF). The Note column refers to specifications where the code allocation is defined.

Table E.6.3.1: E-DCH Downlink Physical Channels Code Allocation for RF testing

Code with SF=64	Code with SF=32	Code with SF=16	Note
0: -	0: -	0: -	P-CPICH, P-CCPCH, PICH, AICH on SF256
1: -			HS-SCCH1 and HS-SCCH2 on SF128
2: S-CCPCH			S-CCPCH: TS 34.108 [3]: 6.1.0b
3: -	1: -		E-HICH/E-RGCH on SF128, E-AGCH on SF256
4: -	2: -	1: HS-PDSCH	1st HS-PDSCH code
5: -			
6: -			
7: -	3: -		
8: -	4: -	2: HS-PDSCH	2nd HS-PDSCH code
9: -			
10: -			
11: -	5: -		
12: -	6: -	3: HS-PDSCH	3rd HS-PDSCH code
13: -			
14: -			
15: -	7: -		
16: -	8: -	4: HS-PDSCH	4th HS-PDSCH code
17: -			
18: -			
19: -	9: -		
20: -	10: -	5: HS-PDSCH	5th HS-PDSCH code
21: -			
22: -			
23: -	11: -		
24: -	12: -	6: -	
25: -			
26: -			
27: -	13: -		
28: -	14: -	7: -	
29: -			
30: -			
31: -	15: -		
32: -	16: -	8: -	
33: -			
34: -			
35: -	17: -		
36: -	18: -	9: -	
37: -			
38: -			
39: -	19: -		
40: -	20: -	10: -	
41: -			
42: -			
43: -	21: -		
44: -	22: -	11: -	
45: -			
46: -			
47: -	23: -		
48: -	24: -	12: -	RMC12.2 on code 96 (SF128), the SRB standalone used during call setup on code 192
49: -			

Code with SF=64	Code with SF=32	Code with SF=16	Note
50: -	25: -		(SF256) (TS 34.108 [3]: 9.2.1)
51: -			
52: -	26: -	13: -	
53: -			
54: -			
55: -	27: -	14: -	
56: -	28: -		
57: -	29: -		
58: -	30: -	15: -	OCNS DPCH on codes 122-127 (SF128)
59: -			
60: -			
61: -			
62: -	31: -		
63: -			

Table E.6.2.2: E-DCH Downlink Physical Channels Code Allocation for SF=16 code=0

Code with SF=256	Code with SF=128	Code with SF=64	Note
0: P-CPICH	0: -	0: -	TS 25.213; 34.108 [3]: 6.1.4; 34.121: E.4.2
1: P-CCPCH			TS 25.213; 34.121: E.4.2
2: PICH	1: -		TS 34.108 [3]: 6.1.0b (SIB5)
3: AICH			TS 34.108 [3]: 6.1.0b (SIB5)
4: -	2: HS-SCCH1	1: -	TS 34.108 [3]: 9.2.1 RB Setup message
5: -	3: HS-SCCH2		
6: -			
7: -	4: -	2: S-CCPCH	S-CCPCH: TS 34.108 [3]: 6.1.0b (SIB5)
8: -	5: -		
9: -	6: E-HICH/E-RGCH		
10: -	7: -	3: -	TS 34.108 [3]: 9.2.1 RB Setup message
11: -			
12: -			
13: -			TS 34.108 [3]: 9.2.1 RB Setup message
14: E-AGCH			
15: -			

E.6.4 Downlink Physical Channels Code Allocation for MBMS test cases

Table E.6.4.1 show the details of downlink code allocation for MBMS test cases. The numbers in the Code columns indicate the code number with the respective spreading factor (SF). The Note column refers to specifications where the code allocation is defined.

Table E.6.4.1: MBMS Downlink Physical Channels Code Allocation for RF testing

Code with SF=256	Code with SF=128	Code with SF=64	Note
0: P-CPICH	0: -	0: -	TS 25.213; TS 34.108 [3]: 6.1.4
1: P-CCPCH			TS 25.213
2: PICH	1: -	0: -	TS 34.108 [3]: 6.1.0b (SIB5)
3: AICH			TS 34.108 [3]: 6.1.0b (SIB5)
4: -	2: OCNS DPCH	1: -	OCNS: TS34.121: Table E.3.6
5: -			
6: -	3: -	1: -	
7: MICH			
8: -	4: -	2: S-CCPCH	2: TS 34.108 [3]: 6.1.0b (SIB5)
9: -			
10: -	5: -	2: S-CCPCH	6: TS 34.121: TC 8.3.5.4
11: -			
12: -	6: S-CCPCH	3: -	
13: -			
14: -	7: -	3: -	
15: -			
16: -	8: -	4: -	
17: -			
18: -	9: -	4: -	
19: -			
20: -	10: -	5: -	
21: -			
22: -	11: OCNS DPCH	5: -	OCNS: TS 34.121: E.3.6
23: -			
24-31: -	12-15: -	6-7: -	
32: -	16: -	8: -	
33: -			
34: -	17: OCNS DPCH	8: -	OCNS: TS 34.121: E.3.6
35: -			
36-43: -	18-21: -	9-10: -	
44: -	22: -	11: -	
45: -			
46: -	23: OCNS DPCH	11: -	OCNS: TS 34.121: E.3.6
47: -			
48-59: -	24-29: -	12-14: -	
60: -	30: -	15: -	
61: -			
62: -	31: OCNS DPCH	15: -	OCNS: TS 34.121: E.3.6
63: -			
64-75: -	32-37: -	16-18: -	
76: -	38: OCNS DPCH	19: -	OCNS: TS 34.121: E.3.6
77: -			
78: -	39: -	19: -	
79: -			
80-91: -	40-45: -	20-22: -	
92: -	46: -	23: -	
93: -			
94: -	47: OCNS DPCH	23: -	OCNS: TS 34.121: E.3.6
95: -			
96-107: -	48-53: -	24-26: -	
108: -	54: -	27: -	
109: -			

Code with SF=256	Code with SF=128	Code with SF=64	Note
110: -	55: OCNS DPCH		OCNS: TS 34.121: E.3.6
111: -			
112-123: -	56-61: -	28-30: -	
124: -	62: OCNS DPCH	31: -	OCNS: TS 34.121: E.3.6
125: -			
126: -	63: -		
127: -			
128-135: -	64-67: -	32-33: -	
136: -	68: -	34: -	
137: -			
138: -	69: OCNS DPCH		OCNS: TS 34.121: E.3.6
139: -			
140-155: -	70-77: -	35-38: -	
156: -	78: OCNS DPCH	39: -	OCNS: TS 34.121: E.3.6
157: -			
158: -	79: -		
159: -			
160-167: -	80-83: -	40-41: -	
168: -	84: -	42: -	
169: -			
170: -	85: OCNS DPCH		OCNS: TS 34.121: E.3.6
171: -			
172-187: -	86-93: -	43-46: -	
188: -	94: OCNS DPCH	47: -	OCNS: TS 34.121: E.3.6
189: -			
190: -	95: -		
191: -			
192: -	96: -	48: -	TS 34.121: TC 8.3.5.4, 8.3.6.3, 11.2(Test 2) MTCH 256kbps: SF8-Code6
193: -			
194: -	97: -		TS 34.121: TC 11.2(Test 1 and 3), 11.3 MTCH 128kbps: SF16-Code12
195: -			
196-223: -	98-111: -	49-55: -	
224: -	112: -	56: -	
225: -			
226: -	113: OCNS DPCH		OCNS: TS 34.121: E.3.6
227: -			
228-235: -	114-117: -	57-58: -	
236: -	118: -	59: -	
237: -			
238: -	119: OCNS DPCH		OCNS: TS 34.121: E.3.6
239: -			
240-59: -	120-123: -	60-61: -	
248: -	124: -	62: -	
249: -			
250: -	125: OCNS DPCH		OCNS: TS 34.121: E.3.6
251: -			
252-255: -	126-127: -	63: -	

Annex F (normative): General test conditions and declarations

The requirements of this clause apply to all applicable tests in the present document.

Many of the tests in the present document measure a parameter relative to a value that is not fully specified in the UE specifications. For these tests, the Minimum Requirement is determined relative to a nominal value specified by the manufacturer.

When specified in a test, the manufacturer shall declare the nominal value of a parameter, or whether an option is supported.

In all the relevant clauses in this clause all Bit Error Ratio (BER), Block Error Ratio (BLER), False transmit format Detection Ratio (FDR) measurements shall be carried out according to the general rules for statistical testing in clause F.6.

F.1 Acceptable uncertainty of Test System

The maximum acceptable uncertainty of the Test System is specified below for each test, where appropriate. The Test System shall enable the stimulus signals in the test case to be adjusted to within the specified range, and the equipment under test to be measured with an uncertainty not exceeding the specified values. All ranges and uncertainties are absolute values, and are valid for a confidence level of 95 %, unless otherwise stated.

A confidence level of 95 % is the measurement uncertainty tolerance interval for a specific measurement that contains 95 % of the performance of a population of test equipment.

For RF tests it should be noted that the uncertainties in clause F.1 apply to the Test System operating into a nominal 50 ohm load and do not include system effects due to mismatch between the DUT and the Test System.

F.1.1 Measurement of test environments

The measurement accuracy of the UE test environments defined in annex G, Test environments shall be.

- Pressure ± 5 kPa.
- Temperature ± 2 degrees.
- Relative Humidity ± 5 %.
- DC Voltage $\pm 1,0$ %.
- AC Voltage $\pm 1,5$ %.
- Vibration 10 %.
- Vibration frequency 0,1 Hz.

The above values shall apply unless the test environment is otherwise controlled and the specification for the control of the test environment specifies the uncertainty for the parameter.

F.1.2 Measurement of transmitter

Table F.1.2: Maximum Test System Uncertainty for transmitter tests

Clause	Maximum Test System Uncertainty	Derivation of Test System Uncertainty
5.2 Maximum Output Power	±0,7 dB	
5.2A Maximum Output Power with HS-DPCCH (Release 5 only)	±0,7 dB	
5.2AA Maximum Output Power with HS-DPCCH (Release 6 and later)	±0,7 dB	
5.2B Maximum Output Power with HS-DPCCH and E-DCH	±0,7 dB	
5.2C UE relative code domain power accuracy	For 0 dB ≥ -10 dB CDP ± 0.2 dB For -10 dB ≥ -15 dB CDP ± 0.3 dB For -15 dB ≥ -20 dB CDP ± 0.4 dB	This accuracy is based on the linearity of the code domain power measurement of the test equipment.
5.2D UE Relative Code Domain Power Accuracy with HS-DPCCH and E-DCH	For 0 dB ≥ -10 dB CDP ± 0.2 dB For -10 dB ≥ -15 dB CDP ± 0.3 dB For -15 dB ≥ -20 dB CDP ± 0.4 dB	This accuracy is based on the linearity of the code domain power measurement of the test equipment.
5.3 Frequency Error	±10 Hz	
5.4.1 Open loop power control in uplink	±1,0 dB	The uncertainty of this test is a combination of the downlink level setting error and the uplink power measurement that are uncorrelated. Formula = SQRT(source_level_error ² + power_meas_error ²)
5.4.2 Inner loop power control in the uplink	The test system uncertainty is the function of the UE transmitter power control range for each combination of the step size and number of steps. For 0 dB and 1 dB range ±0,1 dB For a nominal 2 dB range ±0,15 dB For a nominal 3 dB range ±0,2 dB For a greater than 3 dB range ±0,3 dB	This accuracy is based on the linearity of the absolute power measurement of the test equipment.
5.4.3 Minimum Output Power	±1,0 dB	Measured on a static signal
5.4.4 Out-of-synchronisation handling of output power: $\frac{DPCCH - E_c}{I_{or}}$	±0,4 dB	0.1 dB uncertainty in DPCCH ratio 0.3 dB uncertainty in \hat{I}_{or}/I_{oc} based on power meter measurement after the combiner Overall error is the sum of the \hat{I}_{or}/I_{oc} ratio error and the DPCCH_Ec/I _{or} ratio. The absolute error of the AWGN loc is not important but is specified as 1.0 dB
5.5.1 Transmit OFF Power: (static case)	±1,0 dB	Measured on a static signal

Clause	Maximum Test System Uncertainty	Derivation of Test System Uncertainty
5.5.2 Transmit ON/OFF time mask (dynamic case)	On power +0,7 dB – 1,0 dB Off power (dynamic case) TBD	Assume asymmetric meas error -1.0 dB / 0.7 dB comprising RSS of: -0.7 dB downlink error plus -0.7 dB meas error, and +0.7 dB for upper limit (assume UE won't go above 24 nominal). For the off power, the accuracy of a two-pass measurement needs to be analysed.
5.6 Change of TFC: power control step size (7 dB step)	±0,3 dB relative over a 9 dB range	
5.7 Power setting in uplink compressed mode:-UE output power	A subset of 5.4.2.	
5.7A HS-DPCCH	The test system uncertainty is the function of the UE transmitter power range for each step size on the HS-DPCCH channel. For 0 dB and 1 dB range ±0,1 dB For a nominal 2 dB range ±0,15 dB For a nominal 3 dB range ±0,2 dB For a greater than 3 dB range ±0,3 dB	This accuracy is based on the linearity of the absolute power measurement of the test equipment.
5.8 Occupied Bandwidth	±100 kHz	Accuracy = ±3*RBW. Assume 30 kHz bandwidth.
5.9 Spectrum emission mask	±1,5 dB	
5.9A Spectrum emission mask with HS-DPCCH	±1,5 dB	
5.9B Spectrum emission mask with E-DCH	±1,5 dB	
5.10 ACLR	5 MHz offset: ± 0,8 dB 10 MHz offset: ± 0,8 dB	
5.10A ACLR with HS-DPCCH	5 MHz offset: ± 0,8 dB 10 MHz offset: ± 0,8 dB	
5.10B ACLR with E-DCH	5 MHz offset: ± 0,8 dB 10 MHz offset: ± 0,8 dB	
5.11 Spurious emissions	± 2,0 dB for UE and coexistence bands for results ≥ -60 dBm ± 3,0 dB for results < -60 dBm Outside above: f ≤ 2.2GHz: ± 1.5 dB 2.2 GHz < f ≤ 4 GHz: ± 2.0 dB f > 4 GHz: ±4.0 dB	

Clause	Maximum Test System Uncertainty	Derivation of Test System Uncertainty
5.12 Transmit Intermodulation	± 2.2 dB	<p>CW Interferer error is 0.7 dB for the UE power RSS with 0.7 dB for CW setting = 1.0 dB</p> <p>Measurement error of intermod product is 0.7 dB for UE power RSS with 0.7 dB for relative = 1.0 dB</p> <p>Interferer has an effect of 2 times on the intermod product so overall test uncertainty is 2×1.0 RSS with 1.0 = 2.2 dB.</p> <p>Apply half any excess test system uncertainty to increase the interferer level</p>
5.13.1 Transmit modulation: EVM	± 2.5 % (for single code)	
5.13.1A Transmit modulation: EVM with HS-DPCCH	± 2.5 % (for single code)	
5.13.1AA Transmit modulation: EVM and phase discontinuity with HS-DPCCH	± 2.5 % (for single code)	
	± 6 degree for Phase discontinuity	
5.13.2 Transmit modulation: peak code domain error	± 1.0 dB	
5.13.2A Relative Code Domain Error	± 0.5 dB	
5.13.2B Relative Code Domain Error with HS-DPCCH and E-DCH	± 0.5 dB	
5.13.3 UE phase discontinuity	± 2.5 % for EVM (for single code)	
	± 10 Hz for Frequency error	
	± 6 degree for Phase discontinuity	
5.13.4 PRACH quality (EVM)	± 2.5 %	
5.13.4 PRACH quality (Frequency error)	± 10 Hz	

F.1.3 Measurement of receiver

Table F.1.3: Maximum Test System Uncertainty for receiver tests

Clause	Maximum Test System Uncertainty	Derivation of Test System Uncertainty
6.2 Reference sensitivity level	± 0.7 dB	
6.3 maximum input level:	± 0.7 dB	<p>The critical parameter is the overall signal level and not the -19 dB DPCH_Ec/Ior ratio.</p> <p>0.7 dB absolute error due to signal measurement</p> <p>DPCH_Ec/Ior ratio error is <0.1 dB but is not important so is ignored</p>
6.3A Maximum Input Level for HS-PDSCH Reception (16QAM)	± 0.7 dB	
6.4 Adjacent channel selectivity (Rel-99 and Rel-4)	± 1.1 dB	<p>Overall system uncertainty comprises three quantities:</p> <ol style="list-style-type: none"> 1. Wanted signal level error 2. Interferer signal level error 3. Additional impact of interferer ACLR <p>Items 1 and 2 are assumed to be uncorrelated so can be root sum squared to provide the ratio error of the two signals. Assume for simplicity this ratio error is linearly added to the interferer ACLR.</p> <p>Test System uncertainty = $\text{SQRT}(\text{wanted_level_error}^2 + \text{interferer_level_error}^2) + \text{ACLR effect}$.</p> <p>The ACLR effect is calculated by:(Formula to follow)</p> <p>(E.g. ACLR at 5 MHz of 51 dB gives additional error of .0765 dB. ACLR of 48 gives error of -0.15 dB.)</p>
6.4A Adjacent channel selectivity (Rel-5 and later releases)	± 1.1 dB	Same as above
6.5 Blocking characteristics	<p>System error with $f < 15$ MHz offset: ± 1.4 dB</p> <p>$f \geq 15$ MHz offset and $f_b \leq 2.2$ GHz: $\pm [1.0]$ dB</p> <p>2.2 GHz $< f \leq 4$ GHz: $\pm [1.7]$ dB</p> <p>$f > 4$ GHz: $\pm [3.1]$ dB</p>	Using ± 0.7 dB for signal and interferer as currently defined and 68 dB ACLR @ 10 MHz.
6.6 Spurious Response	<p>$f \leq 2.2$ GHz: ± 1.0 dB</p> <p>2.2 GHz $< f \leq 4$ GHz: ± 1.7 dB</p> <p>$f > 4$ GHz: ± 3.1 dB</p>	

Clause	Maximum Test System Uncertainty	Derivation of Test System Uncertainty
6.7 Intermodulation Characteristics	±1.3 dB	<p>Similar issues to 7.4 ACS test.</p> <p>ETR028 says impact f the closer signal is twice that of the far signal. If both signals drop 1 dB, intermod product drops 2 dB.</p> <p>Formula =</p> $\sqrt{(2 \cdot CW_level_error)^2 + (mod_level_error)^2}$ <p>(Using CW interferer ±0.5 dB, modulated interferer ±0.5 dB, wanted signal ±0.7 dB) 1.3 dB!</p> <p>Broadband noise/ACLR not considered but may have impact.</p>
6.8 Spurious emissions	<p>± 3.0 dB for UE receive band and UE transmit band (-60 dBm)</p> <p>Outside above:</p> <p>f ≤ 2.2GHz: ± 2.0 dB (-57 dBm)</p> <p>2.2 GHz < f ≤ 4 GHz: ± 2.0 dB (-47 dBm)</p> <p>f > 4 GHz: ±4.0 dB (-47 dBm)</p> <p>Downlink signal \hat{f} or ± 2.0 dB</p>	

F.1.4 Performance requirement

Table F.1.4: Maximum Test System Uncertainty for Performance Requirements

Clause	Maximum Test System Uncertainty	Derivation of Test System Uncertainty
7.2 Demodulation in Static Propagation Condition	\hat{I}_{or}/I_{oc} ± 0.3 dB I_{oc} ± 1.0 dB $\frac{DPCH_E_c}{I_{or}}$ ± 0.1 dB	<p>0.1 dB uncertainty in DPCH_Ec ratio</p> <p>0.3 dB uncertainty in \hat{I}_{or}/I_{oc} based on power meter measurement after the combiner</p> <p>Overall error is the sum of the \hat{I}_{or}/I_{oc} ratio error and the DPCH_Ec/Ior ratio but is not RSS for simplicity. The absolute error of the AWGN loc is not important for any tests in clause 7 but is specified as 1.0 dB.</p>
7.3 Demodulation of DCH in multipath Fading Propagation conditions	\hat{I}_{or}/I_{oc} ± 0.56 dB I_{oc} ± 1.0 dB $\frac{DPCH_E_c}{I_{or}}$ ± 0.1 dB	<p>Worst case gain uncertainty due to the fader from the calibrated static profile is ± 0.5 dB</p> <p>In addition the same ± 0.3 dB \hat{I}_{or}/I_{oc} ratio error as 7.2.</p> <p>These are uncorrelated so can be RSS.</p> <p>Overall error in \hat{I}_{or}/I_{oc} is $(0.5^2 + 0.3^2)^{0.5} = 0.6$ dB</p>
7.4 Demodulation of DCH in Moving Propagation conditions	\hat{I}_{or}/I_{oc} ± 0.6 dB I_{oc} ± 1.0 dB $\frac{DPCH_E_c}{I_{or}}$ ± 0.1 dB	Same as 7.3
7.5 Demodulation of DCH in Birth-Death Propagation conditions	\hat{I}_{or}/I_{oc} ± 0.6 dB I_{oc} ± 1.0 dB $\frac{DPCH_E_c}{I_{or}}$ ± 0.1 dB	Same as 7.3
7.5A Demodulation of DCH in high speed train conditions	\hat{I}_{or}/I_{oc} ± 0.6 dB I_{oc} ± 1.0 dB $\frac{DPCH_E_c}{I_{or}}$ ± 0.1 dB	Same as 7.3

Clause	Maximum Test System Uncertainty	Derivation of Test System Uncertainty
7.6.1 Demodulation of DCH in open loop Transmit diversity mode	\hat{I}_{or}/I_{oc} ± 0.8 dB I_{oc} ± 1.0 dB $\frac{DPCH - E_c}{I_{or}}$ ± 0.1 dB	<p>Worst case gain uncertainty due to the fader from the calibrated static profile is ± 0.5 dB per output</p> <p>In addition the same ± 0.3 dB \hat{I}_{or}/I_{oc} ratio error as 7.2.</p> <p>These are uncorrelated so can be RSS.</p> <p>Overall error in \hat{I}_{or}/I_{oc} is $(0.5^2 + 0.5^2 + 0.3^2)^{0.5} = 0.768$ dB. Round up to 0.8 dB</p>
7.6.2 Demodulation of DCH in closed loop Transmit diversity mode	\hat{I}_{or}/I_{oc} ± 0.8 dB I_{oc} ± 1.0 dB $\frac{DPCH - E_c}{I_{or}}$ ± 0.1 dB	Same as 7.6.1
7.6.3, Demodulation of DCH in site selection diversity Transmission power control mode	\hat{I}_{or}/I_{oc} ± 0.8 dB I_{oc} ± 1.0 dB $\frac{DPCH - E_c}{I_{or}}$ ± 0.1 dB	Same as 7.6.1
7.7.1 Demodulation in inter-cell soft Handover (Release 5 and earlier)	\hat{I}_{or1}/I_{oc} ± 0.6 dB \hat{I}_{or2}/I_{oc} ± 0.6 dB I_{oc} ± 1.0 dB $\frac{DPCH - E_c}{I_{or}}$ ± 0.1 dB	<p>Worst case gain uncertainty due to the fader from the calibrated static profile is ± 0.5 dB per output</p> <p>In addition the same ± 0.3 dB \hat{I}_{or}/I_{oc} ratio error as 7.2.</p> <p>These are uncorrelated so can be RSS.</p> <p>Overall error in \hat{I}_{or}/I_{oc} is $(0.5^2 + 0.5^2 + 0.3^2)^{0.5} = 0.768$ dB, but per output \hat{I}_{or1}/I_{oc} or \hat{I}_{or2}/I_{oc} the error is $(0.5^2 + 0.3^2)^{0.5} = 0.6$ dB.</p>
7.7.1A Demodulation in inter-cell soft Handover (Release 6 and later)	\hat{I}_{or1}/I_{oc} ± 0.6 dB \hat{I}_{or2}/I_{oc} ± 0.6 dB I_{oc} ± 1.0 dB $\frac{DPCH - E_c}{I_{or}}$ ± 0.1 dB	<p>Worst case gain uncertainty due to the fader from the calibrated static profile is ± 0.5 dB per output</p> <p>In addition the same ± 0.3 dB \hat{I}_{or}/I_{oc} ratio error as 7.2.</p> <p>These are uncorrelated so can be RSS.</p> <p>Overall error in \hat{I}_{or}/I_{oc} is $(0.5^2 + 0.5^2 + 0.3^2)^{0.5} = 0.768$ dB, but per output \hat{I}_{or1}/I_{oc} or \hat{I}_{or2}/I_{oc} the error is $(0.5^2 + 0.3^2)^{0.5} = 0.6$ dB.</p>

Clause	Maximum Test System Uncertainty	Derivation of Test System Uncertainty
7.7.2 Combining of TPC commands Test 1	I_{or1}, I_{or2} ±1.0 dB $\frac{DPCH_E_c}{I_{or}}$ ±0.1 dB	Test is looking for changes in power – need to allow for relaxation in criteria for power step of probably 0.1 dB to 0.4 dB
7.7.2 Combining of TPC commands Test 2	\hat{I}_{or1}/I_{oc} ±0.6 dB \hat{I}_{or2}/I_{oc} ±0.6 dB I_{oc} ±1.0 dB $\frac{DPCH_E_c}{I_{or}}$ ±0.1 dB	Same as 7.7.1
7.7.3 Combining of reliable TPC commands from radio links of different radio link sets	\hat{I}_{or1}/I_{oc} ±0.3 dB \hat{I}_{or2}/I_{oc} ±0.3 dB \hat{I}_{or3}/I_{oc} ±0.3 dB I_{oc} ±1.0 dB $\frac{DPCH_E_{c1}}{I_{or1}}$ ±0.1 dB $\frac{DPCH_E_{c2}}{I_{or2}}$ ±0.1 dB $\frac{DPCH_E_{c3}}{I_{or3}}$ ±0.1 dB Offset of $\frac{DPCH_E_{c2}}{I_{or1}}$ relative to $\frac{DPCH_E_{c1}}{I_{or1}}$ ±0.4 dB Offset of $\frac{DPCH_E_{c3}}{I_{or1}}$ relative to $\frac{DPCH_E_{c1}}{I_{or1}}$ ±0.4 dB	Same as 7.2. Offsets calculated as RMS of: I_{or1}/I_{oc} , $DPCH_Ec1/I_{or1}$ and $DPCH_Ec2/I_{or2}$ and I_{or1}/I_{oc} , $DPCH_Ec1/I_{or1}$ and $DPCH_Ec3/I_{or3}$ respectively.

Clause	Maximum Test System Uncertainty	Derivation of Test System Uncertainty
7.8.1 Power control in downlink constant BLER target	\hat{I}_{or}/I_{oc} ± 0.6 dB I_{oc} ± 1.0 dB $\frac{DPCH - E_c}{I_{or}}$ ± 0.1 dB	<p>Same as 7.3</p> <p>For test cases wherein the SS response time to DL power control commands is delayed by one timeslot from the immediate response then additional test system uncertainty in $\frac{DPCH - E_c}{I_{or}}$ is applied:</p> <p>For test 1 an additional 0.3 dB is allowed. This value is based on a rounded 0.24 dB delta value from simulations.</p> <p>For test 2 an additional 0.2 dB is allowed. This value is based on a rounded 0.14 dB delta value from simulations.</p>
7.8.2, Power control in downlink initial convergence	\hat{I}_{or}/I_{oc} ± 0.6 dB I_{oc} ± 1.0 dB $\frac{DPCH - E_c}{I_{or}}$ ± 0.1 dB	<p>Same as 7.3.</p> <p>When the SS response time to DL power control commands is delayed by one timeslot from the immediate response, then additional test system uncertainty in $\frac{DPCH - E_c}{I_{or}}$ of 0.2 db is applied. This value is based on a rounded 0.15 dB delta value from simulations.</p>
7.8.3, Power control in downlink: wind up effects	\hat{I}_{or}/I_{oc} ± 0.6 dB I_{oc} ± 1.0 dB $\frac{DPCH - E_c}{I_{or}}$ ± 0.1 dB	<p>Same as 7.3.</p> <p>For test cases wherein the SS response time to DL power control commands is delayed by one timeslot from the immediate response, then additional test system uncertainty in $\frac{DPCH - E_c}{I_{or}}$ is applied:</p> <p>For test 1 an additional 0.3 dB is allowed. This value is based on a rounded 0.26 dB delta value from simulations.</p>

Clause	Maximum Test System Uncertainty	Derivation of Test System Uncertainty
7.8.4, Power control in the downlink, different transport formats	\hat{I}_{or}/I_{oc} ± 0.6 dB I_{oc} ± 1.0 dB $\frac{DPCH_E_c}{I_{or}}$ ± 0.1 dB	<p>Same as 7.3</p> <p>For test cases where the SS response time to DL power control commands is delayed by one timeslot from the immediate response, then additional test system uncertainty in $\frac{DPCH_E_c}{I_{or}}$ is applied:</p> <p>For test 1 stage 1, an additional 0.2 dB is allowed. This value is based on a rounded 0.24 dB delta value from simulations.</p> <p>For test 1 stage 2, an additional 0.1 dB is allowed. This value is based on a rounded 0.16 dB delta value from simulations.</p>
7.9 Downlink compressed mode	\hat{I}_{or}/I_{oc} ± 0.6 dB I_{oc} ± 1.0 dB $\frac{DPCH_E_c}{I_{or}}$ ± 0.1 dB	Same as 7.3
7.10 Blind transport format detection Tests 1, 2, 3	\hat{I}_{or}/I_{oc} ± 0.3 dB I_{oc} ± 1.0 dB $\frac{DPCH_E_c}{I_{or}}$ ± 0.1 dB	Same as 7.2
7.10 Blind transport format detection Tests 4, 5, 6	\hat{I}_{or}/I_{oc} ± 0.6 dB I_{oc} ± 1.0 dB $\frac{DPCH_E_c}{I_{or}}$ ± 0.1 dB	Same as 7.3
7.11 Demodulation of paging channel (PCH)	Test 1: \hat{I}_{or}/I_{oc} ± 0.3 dB I_{oc} ± 1.0 dB S-CCPCH_Ec/lor ± 0.1 dB PICH_Ec/lor ± 0.1 dB	Test 1: Values for \hat{I}_{or}/I_{oc} and I_{oc} are the same as 7.2 Uncertainties for S-CCPCH_Ec/lor and PICH_Ec/lor are the same as for DPCH_Ec/lor
	Test 2: \hat{I}_{or}/I_{oc} ± 0.6 dB I_{oc} ± 1.0 dB S-CCPCH_Ec/lor ± 0.1 dB PICH_Ec/lor ± 0.1 dB	Test 2: Values for \hat{I}_{or}/I_{oc} and I_{oc} are the same as 7.3 Uncertainties for S-CCPCH_Ec/lor and PICH_Ec/lor are the same as for DPCH_Ec/lor
7.12 Detection of acquisition indicator (AI)	\hat{I}_{or}/I_{oc} ± 0.3 dB I_{oc} ± 1.0 dB AICH_Ec/lor ± 0.1 dB S-CCPCH_Ec/lor ± 0.1 dB	Values for \hat{I}_{or}/I_{oc} and I_{oc} are the same as 7.2 Uncertainty for AICH_Ec/lor and S-CCPCH_Ec/lor is the same as for DPCH_Ec/lor

F.1.5 Requirements for support of RRM

Table F.1.5: Maximum Test System Uncertainty for Radio Resource Management Tests

Clause	Maximum Test System Uncertainty	Derivation of Test System Uncertainty
8.2 Idle Mode Tasks		
8.2.2 Cell Re-Selection		
8.2.2.1 Scenario 1: Single carrier case	<p><u>During T1 and T2:</u></p> $\frac{CPICH - E_c}{I_{or}} \quad \pm 0.1 \text{ dB}$ $I_{oc} \quad \pm 1.0 \text{ dB}$ <p><u>During T1:</u></p> $I_{or} (2) \quad \pm 0.7 \text{ dB}$ $I_{or} (1, 3, 4, 5, 6) \text{ relative to } I_{or} (2) \quad \pm 0.3 \text{ dB}$ <p><u>During T2:</u></p> $I_{or} (1) \quad \pm 0.7 \text{ dB}$ $I_{or} (2, 3, 4, 5, 6) \text{ relative to } I_{or} (1) \quad \pm 0.3 \text{ dB}$ <p>Assumptions:</p> <p>a) The contributing uncertainties for $I_{or}(n)$, channel power ratio, and I_{oc} are derived according to ETR 273-1-2 [16], with a coverage factor of $k=2$.</p> <p>b) Within each cell, the uncertainty for $I_{or}(n)$, and channel power ratio are uncorrelated to each other.</p> <p>c) The relative uncertainties for $I_{or}(n)$ across different cells may have any amount of positive correlation from zero (uncorrelated) to one (fully correlated).</p> <p>d) Across different cells, the channel power ratio uncertainties may have any amount of positive correlation from zero (uncorrelated) to one (fully correlated).</p> <p>e) The uncertainty for I_{oc} and $I_{or}(n)$ may have any amount of positive correlation from zero (uncorrelated) to one (fully correlated).</p> <p>f) The absolute uncertainty of $I_{or}(2)$ at T1 and the relative uncertainty of $I_{or}(1, 3, 4, 5, 6)$, are uncorrelated to each other. Similarly, the absolute uncertainty of $I_{or}(1)$ at T2 and the relative uncertainty of $I_{or}(2, 3, 4, 5, 6)$, are uncorrelated to each other.</p> <p>An explanation of correlation between uncertainties, and of the rationale behind the assumptions, is recorded in 3GPP TR 34 902 [24].</p>	

Clause	Maximum Test System Uncertainty	Derivation of Test System Uncertainty
8.2.2.2 Scenario 2: Multi carrier case	<p><u>Channel 1 during T1 and T2:</u></p> $\frac{CPICH - E_c}{I_{or}} \quad \pm 0.1 \text{ dB}$ $I_{oc}(1) \quad \pm 1.0 \text{ dB}$ <p><u>Channel 1 during T1:</u></p> $I_{or}(1) \quad \pm 0.7 \text{ dB}$ <p>$I_{or}(3, 4)$ relative to $I_{or}(1)$ $\pm 0.3 \text{ dB}$</p> <p><u>Channel 1 during T2:</u></p> $I_{or}(1) \quad \pm 0.7 \text{ dB}$ <p>$I_{or}(3, 4)$ relative to $I_{or}(1)$ $\pm 0.3 \text{ dB}$</p> <p><u>Channel 2 during T1 and T2:</u></p> $\frac{CPICH - E_c}{I_{or}} \quad \pm 0.1 \text{ dB}$ $I_{oc}(2) \quad \pm 1.0 \text{ dB}$ <p><u>Channel 2 during T1:</u></p> $I_{or}(2) \quad \pm 0.7 \text{ dB}$ <p>$I_{or}(5, 6)$ relative to $I_{or}(2)$ $\pm 0.3 \text{ dB}$</p> <p><u>Channel 2 during T2:</u></p> $I_{or}(2) \quad \pm 0.7 \text{ dB}$ <p>$I_{or}(5, 6)$ relative to $I_{or}(2)$ $\pm 0.3 \text{ dB}$</p> <p>Assumptions: a) to e): Same as for the one-frequency test 8.2.2.1. f) The absolute uncertainty of $I_{or}(1)$ and the relative uncertainty of $I_{or}(3, 4)$, are uncorrelated to each other. Similarly, the absolute uncertainty of $I_{or}(2)$ and the relative uncertainty of $I_{or}(5, 6)$, are uncorrelated to each other. g) The absolute uncertainties for $I_{or}(1)$ and $I_{or}(2)$ may have any amount of positive correlation from zero (uncorrelated) to one (fully correlated). h) The absolute uncertainties for $I_{oc}(1)$ and $I_{oc}(2)$ may have any amount of positive correlation from zero (uncorrelated) to one (fully correlated). An explanation of correlation between uncertainties, and of the rationale behind the assumptions, is recorded in 3GPP TR 34 902 [24].</p>	
8.2.3 UTRAN to GSM Cell Re-Selection		

Clause	Maximum Test System Uncertainty	Derivation of Test System Uncertainty
8.2.3.1 Scenario 1: Both UTRA and GSM level changed	\hat{I}_{or}/I_{oc} ±0.3 dB $I_{oc}/RXLEV$ ±0.5 dB I_{oc} ±1.0 dB RXLEV ±1.0 dB $\frac{CPICH - E_c}{I_{or}}$ ±0.1 dB	0.1 dB uncertainty in CPICH_Ec ratio 0.3 dB uncertainty in \hat{I}_{or}/I_{oc} based on power meter measurement after the combiner 0.5 dB uncertainty in loc/RXLEV based on power meter measurement after the combiner The absolute error of the AWGN is specified as 1.0 dB. The absolute error of the RXLEV is specified as 1.0 dB.
8.2.3.2 Scenario 2: Only UTRA level changed	\hat{I}_{or}/I_{oc} ±0.3 dB $I_{oc}/RXLEV$ ±0.5 dB I_{oc} ±1.0 dB RXLEV ±1.0 dB $\frac{CPICH - E_c}{I_{or}}$ ±0.1 dB	Same as 8.2.3.1
8.2.3.3 Scenario 3: HCS with only UTRA level changed	\hat{I}_{or}/I_{oc} ±0.3 dB $I_{oc}/RXLEV$ ±0.5 dB I_{oc} ±1.0 dB RXLEV ±1.0 dB $\frac{CPICH - E_c}{I_{or}}$ ±0.1 dB	Same as 8.2.3.1
8.2.4 FDD/TDD cell re-selection	\hat{I}_{or}/I_{oc} ±0.3 dB I_{oc} ±1.0 dB I_{oc1}/I_{oc2} ±0.3 dB $\frac{CPICH - E_c}{I_{or}}$ ±0.1 dB	Same as 8.2.2.2
8.3 UTRAN Connected Mode Mobility		

Clause	Maximum Test System Uncertainty	Derivation of Test System Uncertainty
8.3.1 FDD/FDD Soft Handover	<p><u>During T0/T1 and T2/T3/T4/T5/T6:</u></p> $\frac{CPICH - E_c}{I_{or}} \quad \pm 0.1 \text{ dB}$ $I_{or}(1) \quad \pm 0.7 \text{ dB}$ $I_{oc} \quad \pm 1.0 \text{ dB}$ <p>Relative delay of paths received from cell 2 with respect to cell 1: ± 0.5 chips</p> <p><u>During T0/T1:</u> Already covered above</p> <p><u>During T2/T3/T4/T5/T6:</u> $I_{or}(2)$ relative to $I_{or}(1) \pm 0.3$ dB</p> <p>Assumptions:</p> <p>a) The contributing uncertainties for $I_{or}(n)$, channel power ratio, and I_{oc} are derived according to ETR 273-1-2 [16], with a coverage factor of $k=2$.</p> <p>b) Within each cell, the uncertainty for $I_{or}(n)$, and channel power ratio are uncorrelated to each other.</p> <p>c) Across different cells, the channel power ratio uncertainties may have any amount of positive correlation from zero (uncorrelated) to one (fully correlated).</p> <p>d) The uncertainty for I_{oc} and $I_{or}(n)$ may have any amount of positive correlation from zero (uncorrelated) to one (fully correlated).</p> <p>e) The absolute uncertainty of $I_{or}(1)$ and the relative uncertainty of $I_{or}(2)$, are uncorrelated to each other.</p> <p>An explanation of correlation between uncertainties, and of the rationale behind the assumptions, is recorded in 3GPP TR 34 902 [24].</p>	
8.3.2 FDD/FDD Hard Handover		
8.3.2.1 Handover to intra-frequency cell	<p><u>During T1 and T2 / T3:</u></p> $\frac{CPICH - E_c}{I_{or}} \quad \pm 0.1 \text{ dB}$ $I_{or}(1) \quad \pm 0.7 \text{ dB}$ $I_{oc} \quad \pm 1.0 \text{ dB}$ <p><u>During T1:</u> Already covered above</p> <p><u>During T2 / T3:</u> $I_{or}(2)$ relative to $I_{or}(1) \pm 0.3$ dB</p>	

Clause	Maximum Test System Uncertainty	Derivation of Test System Uncertainty
	<p>Assumptions:</p> <p>a) The contributing uncertainties for $I_{or}(n)$, channel power ratio, and I_{oc} are derived according to ETR 273-1-2 [16], with a coverage factor of $k=2$.</p> <p>b) Within each cell, the uncertainty for $I_{or}(n)$, and channel power ratio are uncorrelated to each other.</p> <p>c) Across different cells, the channel power ratio uncertainties may have any amount of positive correlation from zero (uncorrelated) to one (fully correlated).</p> <p>d) The uncertainty for I_{oc} and $I_{or}(n)$ may have any amount of positive correlation from zero (uncorrelated) to one (fully correlated).</p> <p>e) The absolute uncertainty of $I_{or}(1)$ and the relative uncertainty of $I_{or}(2)$, are uncorrelated to each other.</p> <p>An explanation of correlation between uncertainties, and of the rationale behind the assumptions, is recorded in 3GPP TR 34 902 [24].</p>	
8.3.2.2 Handover to inter-frequency cell	<p><u>Channel 1 during T1 and T2 / T3:</u></p> $\frac{CPICH - E_c}{I_{or}} \quad \pm 0.1 \text{ dB}$ $I_{or}(1) \quad \pm 0.7 \text{ dB}$ $I_{oc}(1) \quad \pm 1.0 \text{ dB}$ <p><u>Channel 2 during T1 and T2 / T3:</u></p> $I_{oc}(2) \quad \pm 1.0 \text{ dB}$ <p><u>Channel 2 during T1:</u> Already covered above</p> <p><u>Channel 2 during T2 / T3:</u></p> $\frac{CPICH - E_c}{I_{or}} \quad \pm 0.1 \text{ dB}$ $I_{or}(2) \quad \pm 0.7 \text{ dB}$ <p>Assumptions:</p> <p>a) The contributing uncertainties for $I_{or}(n)$, channel power ratio, and I_{oc} are derived according to ETR 273-1-2 [16], with a coverage factor of $k=2$.</p> <p>b) Within each cell, the uncertainty for $I_{or}(n)$, and channel power ratio are uncorrelated to each other.</p> <p>c) Across different cells, the channel power ratio uncertainties may have any amount of positive correlation from zero (uncorrelated) to one (fully correlated).</p> <p>d) The uncertainty for $I_{oc}(n)$ and $I_{or}(n)$ may have any amount of positive correlation from zero (uncorrelated) to one (fully correlated).</p> <p>e) The absolute uncertainties for $I_{or}(1)$ and $I_{or}(2)$ may have any amount of positive correlation from zero (uncorrelated) to one (fully correlated).</p> <p>f) The absolute uncertainties for $I_{oc}(1)$ and $I_{oc}(2)$ may have any amount of positive correlation from zero (uncorrelated) to one (fully correlated).</p> <p>An explanation of correlation between uncertainties, and of the rationale behind the assumptions, is recorded in 3GPP TR 34 902 [24].</p>	
8.3.3 FDD/TDD Handover	TBD	

Clause	Maximum Test System Uncertainty	Derivation of Test System Uncertainty
8.3.4 Inter-system Handover from UTRAN FDD to GSM	\hat{I}_{or}/I_{oc} ± 0.3 dB $I_{oc}/RXLEV$ ± 0.5 dB I_{oc} ± 1.0 dB RXLEV ± 1.0 dB $\frac{CPICH - E_c}{I_{or}}$ ± 0.1 dB	0.1 dB uncertainty in CPICH_Ec ratio 0.3 dB uncertainty in \hat{I}_{or}/I_{oc} based on power meter measurement after the combiner 0.5 dB uncertainty in loc/RXLEV based on power meter measurement after the combiner The absolute error of the AWGN is specified as 1.0 dB. The absolute error of the RXLEV is specified as 1.0 dB.
8.3.5 Cell Re-selection in CELL_FACH 8.3.5.1 One frequency present in the neighbour list	<u>During T1 and T2:</u> $\frac{CPICH - E_c}{I_{or}}$ ± 0.1 dB I_{oc} ± 1.0 dB <u>During T1:</u> $I_{or}(2)$ ± 0.7 dB $I_{or}(1, 3, 4, 5, 6)$ relative to $I_{or}(2)$ ± 0.3 dB <u>During T2:</u> $I_{or}(1)$ ± 0.7 dB $I_{or}(2, 3, 4, 5, 6)$ relative to $I_{or}(1)$ ± 0.3 dB	

Clause	Maximum Test System Uncertainty	Derivation of Test System Uncertainty
		<p>Assumptions:</p> <p>a) The contributing uncertainties for $\text{lor}(n)$, channel power ratio, and loc are derived according to ETR 273-1-2 [16], with a coverage factor of $k=2$.</p> <p>b) Within each cell, the uncertainty for $\text{lor}(n)$, and channel power ratio are uncorrelated to each other.</p> <p>c) The relative uncertainties for $\text{lor}(n)$ across different cells may have any amount of positive correlation from zero (uncorrelated) to one (fully correlated).</p> <p>d) Across different cells, the channel power ratio uncertainties may have any amount of positive correlation from zero (uncorrelated) to one (fully correlated).</p> <p>e) The uncertainty for loc and $\text{lor}(n)$ may have any amount of positive correlation from zero (uncorrelated) to one (fully correlated).</p> <p>f) The absolute uncertainty of $\text{lor}(2)$ at T1 and the relative uncertainty of $\text{lor}(1, 3, 4, 5, 6)$, are uncorrelated to each other. Similarly, the absolute uncertainty of $\text{lor}(1)$ at T2 and the relative uncertainty of $\text{lor}(2, 3, 4, 5, 6)$, are uncorrelated to each other.</p> <p>An explanation of correlation between uncertainties, and of the rationale behind the assumptions, is recorded in 3GPP TR 34 902 [24].</p>

Clause	Maximum Test System Uncertainty	Derivation of Test System Uncertainty
<p>8.3.5.2 Two frequencies present in the neighbour list</p>	<p><u>Channel 1 during T1 and T2:</u></p> $\frac{CPICH - E_c}{I_{or}} \quad \pm 0.1 \text{ dB}$ <p>$I_{oc}(1) \quad \pm 1.0 \text{ dB}$</p> <p><u>Channel 1 during T1:</u></p> $I_{or}(1) \quad \pm 0.7 \text{ dB}$ <p>$I_{or}(3, 4) \text{ relative to } I_{or}(1) \quad \pm 0.3 \text{ dB}$</p> <p><u>Channel 1 during T2:</u></p> $I_{or}(1) \quad \pm 0.7 \text{ dB}$ <p>$I_{or}(3, 4) \text{ relative to } I_{or}(1) \quad \pm 0.3 \text{ dB}$</p> <p><u>Channel 2 during T1 and T2:</u></p> $\frac{CPICH - E_c}{I_{or}} \quad \pm 0.1 \text{ dB}$ <p>$I_{oc}(2) \quad \pm 1.0 \text{ dB}$</p> <p><u>Channel 2 during T1:</u></p> $I_{or}(2) \quad \pm 0.7 \text{ dB}$ <p>$I_{or}(5, 6) \text{ relative to } I_{or}(2) \quad \pm 0.3 \text{ dB}$</p> <p><u>Channel 2 during T2:</u></p> $I_{or}(2) \quad \pm 0.7 \text{ dB}$ <p>$I_{or}(5, 6) \text{ relative to } I_{or}(2) \quad \pm 0.3 \text{ dB}$</p>	
	<p>Assumptions:</p> <p>a) to e): Same as for the one-frequency test 8.3.5.1.</p> <p>f) The absolute uncertainty of $I_{or}(1)$ and the relative uncertainty of $I_{or}(3, 4)$, are uncorrelated to each other. Similarly, the absolute uncertainty of $I_{or}(2)$ and the relative uncertainty of $I_{or}(5, 6)$, are uncorrelated to each other.</p> <p>g) The absolute uncertainties for $I_{or}(1)$ and $I_{or}(2)$ may have any amount of positive correlation from zero (uncorrelated) to one (fully correlated).</p> <p>h) The absolute uncertainties for $I_{oc}(1)$ and $I_{oc}(2)$ may have any amount of positive correlation from zero (uncorrelated) to one (fully correlated).</p> <p>An explanation of correlation between uncertainties, and of the rationale behind the assumptions is recorded in 3GPP TR 34 902 [24].</p>	

Clause	Maximum Test System Uncertainty	Derivation of Test System Uncertainty
8.3.5.3 Cell Re-selection to GSM	\hat{I}_{or}/I_{oc} ± 0.3 dB $I_{oc}/RXLEV$ ± 0.5 dB I_{oc} ± 1.0 dB RXLEV ± 1.0 dB $\frac{CPICH - E_c}{I_{or}}$ ± 0.1 dB	0.1 dB uncertainty in CPICH_Ec ratio 0.3 dB uncertainty in \hat{I}_{or}/I_{oc} based on power meter measurement after the combiner 0.5 dB uncertainty in loc/RXLEV based on power meter measurement after the combiner The absolute error of the AWGN is specified as 1.0 dB. The absolute error of the RXLEV is specified as 1.0 dB.
8.3.6 Cell Re-selection in CELL_PCH		
8.3.6.1 One frequency present in the neighbour list	Same as 8.2.2.1	Same as 8.2.2.1
8.3.6.2 Two frequencies present in the neighbour list	Same as 8.2.2.2	Same as 8.2.2.2
8.3.6.3 Cell re-selection during an MBMS session, one UTRAN inter-frequency and 2 GSM cells present in the neighbour list	TBD	TBD
8.3.7 Cell Re-selection in URA_PCH		
8.3.7.1 One frequency present in the neighbour list	Same as 8.2.2.1	Same as 8.2.2.1
8.3.7.2 Two frequencies present in the neighbour list	Same as 8.2.2.2	Same as 8.2.2.2
8.3.8 Serving HS-DSCH cell change	<u>During T0 and T1/T2/T3/T4:</u> $\frac{CPICH - E_c}{I_{or}}$ ± 0.1 dB $I_{or}(1)$ ± 0.7 dB I_{oc} ± 1.0 dB Relative delay of paths received from cell 2 with respect to cell 1: ± 0.5 chips <u>During T0:</u> Already covered above <u>During T1/T2/T3/T4/T5/T6:</u> $I_{or}(2)$ relative to $I_{or}(1) \pm 0.3$ dB	

Clause	Maximum Test System Uncertainty	Derivation of Test System Uncertainty
	Assumptions: a) The contributing uncertainties for $I_{or}(n)$, channel power ratio, and I_{oc} are derived according to ETR 273-1-2 [16], with a coverage factor of $k=2$. b) Within each cell, the uncertainty for $I_{or}(n)$, and channel power ratio are uncorrelated to each other. c) Across different cells, the channel power ratio uncertainties may have any amount of positive correlation from zero (uncorrelated) to one (fully correlated). d) The uncertainty for I_{oc} and $I_{or}(n)$ may have any amount of positive correlation from zero (uncorrelated) to one (fully correlated). e) The absolute uncertainty of $I_{or}(1)$ and the relative uncertainty of $I_{or}(2)$, are uncorrelated to each other. An explanation of correlation between uncertainties, and of the rationale behind the assumptions, is recorded in 3GPP TR 34 902 [24].	
8.4 RRC Connection Control 8.4.1 RRC Re-establishment delay	Settings. \hat{I}_{or}/I_{oc} ± 0.3 dB I_{oc} ± 1.0 dB $\frac{CPICH_Ec}{I_{or}}$ ± 0.1 dB	0.1 dB uncertainty in CPICH_Ec ratio 0.3 dB uncertainty in \hat{I}_{or}/I_{oc} based on power meter measurement after the combiner Overall error is the sum of the \hat{I}_{or}/I_{oc} ratio error and the CPICH_Ec/Ior ratio. The absolute error of the AWGN is specified as 1.0 dB
8.4.2 Random Access	Settings. \hat{I}_{or}/I_{oc} ± 0.3 dB I_{oc} ± 1.0 dB $\frac{AICH_Ec}{I_{or}}$ ± 0.1 dB Measurements: Power difference: ± 1 dB Maximum Power: same as 5.5.2	0.1 dB uncertainty in AICH_Ec ratio 0.3 dB uncertainty in \hat{I}_{or}/I_{oc} based on power meter measurement after the combiner Overall error is the sum of the \hat{I}_{or}/I_{oc} ratio error and the AICH_Ec/Ior ratio. The absolute error of the AWGN is specified as 1.0 dB Power difference: Assume symmetric meas error ± 1.0 dB comprising RSS of: -0.7 dB downlink error plus -0.7 dB meas error. Maximum Power: Assume asymmetric meas error -1.0 dB / 0.7 dB comprising RSS of: -0.7 dB downlink error plus -0.7 dB meas error, and +0.7 dB for upper limit

Clause	Maximum Test System Uncertainty	Derivation of Test System Uncertainty
	PRACH timing error ± 0.5 chips	
8.4.3 Transport format combination selection in UE	$\frac{DPCH - E_c}{I_{or}}$ ± 0.1 dB	0.1 dB uncertainty in DPCH_Ec ratio
8.4.4 E-TFC restriction in UE		
8.4.4.1 10ms TTI E-DCH E-TFC restriction	$\frac{E_c}{I_{or}}$ ± 0.1 dB I_{or} ± 0.7 dB DPCCH code domain absolute power measurement uncertainty ± 0.9 dB	0.1 dB uncertainty in Ec/Ior ratio Absolute power uncertainty (all codes together) ± 0.7 dB, relative code domain power uncertainty ± 0.5 dB, These are uncorrelated so can be combined RSS. Overall error is $(0.5^2 + 0.7^2)^{0.5} = 0.9$ dB,
8.4.4.2 2ms TTI E-DCH E-TFC restriction	$\frac{E_c}{I_{or}}$ ± 0.1 dB I_{or} ± 0.7 dB DPCCH code domain absolute power measurement uncertainty ± 0.9 dB	0.1 dB uncertainty in Ec/Ior ratio Same as 8.4.4.1
8.5 Timing and Signalling Characteristics		
8.5.1 UE Transmit Timing	I_{or} ± 1.0 dB I_{or1}/I_{or2} ± 0.3 dB $\frac{DPCH - E_c}{I_{or}}$ ± 0.1 dB $\frac{CPICH - E_c}{I_{or}}$ ± 0.1 dB Rx-Tx Timing Accuracy ± 0.5 chips Tx-Tx Timing Accuracy ± 0.25 chips	0.1 dB uncertainty in DPCH_Ec ratio 0.3 dB uncertainty in Ior1/Ior2 based on power meter measurement after the combiner The absolute error of the Ior is specified as 1.0 dB.
8.6 UE Measurements Procedures		
8.6.1 FDD intra frequency measurements		
8.6.1.1 Event triggered reporting in AWGN propagation conditions (R99)	<u>During T1/T4 and T2/T3:</u> $\frac{CPICH - E_c}{I_{or}}$ ± 0.1 dB $I_{or}(1)$ ± 0.7 dB I_{oc} ± 1.0 dB <u>During T1/T4 only:</u> Already covered above <u>During T2/T3 only:</u> $I_{or}(2)$ relative to $I_{or}(1)$ ± 0.3 dB	

Clause	Maximum Test System Uncertainty	Derivation of Test System Uncertainty
8.6.1.1A Event triggered reporting in AWGN propagation conditions (Rel-4 and later)	<p><u>During T1/T3 and T2:</u></p> $\frac{CPICH - E_c}{I_{or}} \quad \pm 0.1 \text{ dB}$ $I_{or} (1) \quad \pm 0.7 \text{ dB}$ $I_{oc} \quad \pm 1.0 \text{ dB}$ <p><u>During T1/T3 only:</u> Already covered above</p> <p><u>During T2 only:</u> $I_{or} (2)$ relative to $I_{or} (1) \pm 0.3 \text{ dB}$</p>	
8.6.1.1 and 8.6.1.1A	<p>Assumptions:</p> <p>a) The contributing uncertainties for $I_{or}(n)$, channel power ratio, and I_{oc} are derived according to ETR 273-1-2 [16], with a coverage factor of $k=2$.</p> <p>b) Within each cell, the uncertainty for $I_{or}(n)$, and channel power ratio are uncorrelated to each other.</p> <p>c) Across different cells, the channel power ratio uncertainties may have any amount of positive correlation from zero (uncorrelated) to one (fully correlated).</p> <p>d) The uncertainty for I_{oc} and $I_{or}(n)$ may have any amount of positive correlation from zero (uncorrelated) to one (fully correlated).</p> <p>e) The absolute uncertainty of $I_{or}(1)$ and the relative uncertainty of $I_{or}(2)$, are uncorrelated to each other.</p> <p>An explanation of correlation between uncertainties, and of the rationale behind the assumptions, is recorded in 3GPP TR 34 902 [24].</p>	
8.6.1.2 Event triggered reporting of multiple neighbours in AWGN propagation condition (R99)	<p><u>During T0 to T6:</u></p> $\frac{CPICH - E_c}{I_{or}} \quad \pm 0.1 \text{ dB}$ $I_{or} (1) \quad \pm 0.7 \text{ dB}$ $I_{oc} \quad \pm 1.0 \text{ dB}$ <p><u>During T1/T2, T3 and T6:</u> $I_{or} (3)$ relative to $I_{or} (1) \pm 0.3 \text{ dB}$</p> <p><u>During T3, T4/T5 and T6:</u> $I_{or} (2)$ relative to $I_{or} (1) \pm 0.3 \text{ dB}$</p>	
<p>Assumptions:</p> <p>a) The contributing uncertainties for $I_{or}(n)$, channel power ratio, and I_{oc} are derived according to ETR 273-1-2 [4], with a coverage factor of $k=2$.</p> <p>b) Within each cell, the uncertainty for $I_{or}(n)$, and channel power ratio are uncorrelated to each other.</p> <p>c) The relative uncertainties for $I_{or}(n)$ across different cells may have any amount of positive correlation from zero (uncorrelated) to one (fully correlated).</p> <p>d) Across different cells, the channel power ratio uncertainties may have any amount of positive correlation from zero (uncorrelated) to one (fully correlated).</p> <p>e) The uncertainty for I_{oc} and $I_{or}(1)$ may have any amount of positive correlation from zero (uncorrelated) to one (fully correlated).</p> <p>f) The absolute uncertainty of $I_{or}(1)$ and the relative uncertainty of $I_{or}(2, 3)$, are uncorrelated to each other.</p>		

Clause	Maximum Test System Uncertainty	Derivation of Test System Uncertainty
8.6.1.2A Event triggered reporting of multiple neighbours in AWGN propagation condition (Rel-4 and later)	<p><u>During T0 to T4:</u></p> $\frac{CPICH - E_c}{I_{or}} \quad \pm 0.1 \text{ dB}$ $I_{or}(1) \quad \pm 0.7 \text{ dB}$ $I_{oc} \quad \pm 1.0 \text{ dB}$ <p><u>During T1, T2 and T4:</u></p> $I_{or}(3) \text{ relative to } I_{or}(1) \pm 0.3 \text{ dB}$ <p><u>During T2, T3 and T4:</u></p> $I_{or}(2) \text{ relative to } I_{or}(1) \pm 0.3 \text{ dB}$ <p><u>Assumptions:</u> Same as 8.6.1.2</p>	
8.6.1.3 Event triggered reporting of two detectable neighbours in AWGN propagation condition (R99)	<p><u>During T0 to T5:</u></p> $\frac{CPICH - E_c}{I_{or}} \quad \pm 0.1 \text{ dB}$ $I_{or}(1) \quad \pm 0.7 \text{ dB}$ $I_{oc} \quad \pm 1.0 \text{ dB}$ <p><u>During T1, T2/T3, T4 and T5:</u></p> $I_{or}(3) \text{ relative to } I_{or}(1) \pm 0.3 \text{ dB}$ <p><u>During T2/T3, T4 and T5:</u></p> $I_{or}(2) \text{ relative to } I_{or}(1) \pm 0.3 \text{ dB}$	
8.6.1.3A Event triggered reporting of two detectable neighbours in AWGN propagation condition (Rel-4 and later)	<p><u>During T0 to T4:</u></p> $\frac{CPICH - E_c}{I_{or}} \quad \pm 0.1 \text{ dB}$ $I_{or}(1) \quad \pm 0.7 \text{ dB}$ $I_{oc} \quad \pm 1.0 \text{ dB}$ <p><u>During T1, T2, T3 and T4:</u></p> $I_{or}(3) \text{ relative to } I_{or}(1) \pm 0.3 \text{ dB}$ <p><u>During T2, T3 and T4:</u></p> $I_{or}(2) \text{ relative to } I_{or}(1) \pm 0.3 \text{ dB}$	

Clause	Maximum Test System Uncertainty	Derivation of Test System Uncertainty
	<p>Assumptions:</p> <p>a) The contributing uncertainties for $I_{or}(n)$, channel power ratio, and I_{oc} are derived according to ETR 273-1-2 [4], with a coverage factor of $k=2$.</p> <p>b) Within each cell, the uncertainty for $I_{or}(n)$, and channel power ratio are uncorrelated to each other.</p> <p>c) The relative uncertainties for $I_{or}(n)$ across different cells may have any amount of positive correlation from zero (uncorrelated) to one (fully correlated).</p> <p>d) Across different cells, the channel power ratio uncertainties may have any amount of positive correlation from zero (uncorrelated) to one (fully correlated).</p> <p>e) The uncertainty for I_{oc} and $I_{or}(1)$ may have any amount of positive correlation from zero (uncorrelated) to one (fully correlated).</p> <p>f) The absolute uncertainty of $I_{or}(1)$ and the relative uncertainty of $I_{or}(2, 3)$, are uncorrelated to each other.</p> <p>An explanation of correlation between uncertainties, and of the rationale behind the assumptions, is recorded in 3GPP TR 34 902 [24].</p>	
8.6.1.4A Correct reporting of neighbours in fading propagation condition (Rel-4 and later)	<p><u>During T1 and T2:</u></p> $\frac{CPICH - E_c}{I_{or}} \quad \pm 0.1 \text{ dB}$ $I_{or}(1) \quad \pm 0.7 \text{ dB}$ $I_{oc} \quad \pm 1.0 \text{ dB}$ <p><u>During T1 and T2:</u></p> $I_{or}(2) \text{ relative to } I_{or}(1) \pm 0.3 \text{ dB}$	
8.6.1.4A	<p>Assumptions:</p> <p>a) The contributing uncertainties for $I_{or}(n)$, channel power ratio, and I_{oc} are derived according to ETR 273-1-2 [16], with a coverage factor of $k=2$.</p> <p>b) Within each cell, the uncertainty for $I_{or}(n)$, and channel power ratio are uncorrelated to each other.</p> <p>c) Across different cells, the channel power ratio uncertainties may have any amount of positive correlation from zero (uncorrelated) to one (fully correlated).</p> <p>d) The uncertainty for I_{oc} and $I_{or}(n)$ may have any amount of positive correlation from zero (uncorrelated) to one (fully correlated).</p> <p>e) The absolute uncertainty of $I_{or}(1)$ and the relative uncertainty of $I_{or}(2)$, are uncorrelated to each other.</p> <p>An explanation of correlation between uncertainties, and of the rationale behind the assumptions, is recorded in 3GPP TR 34 902 [24].</p>	

Clause	Maximum Test System Uncertainty	Derivation of Test System Uncertainty
<p>8.6.1.5 Event triggered reporting of multiple neighbour cells in Case 1 fading condition</p>	<p><u>During T1 and T2:</u> $\frac{CPICH - E_c}{I_{or}} \quad \pm 0.1 \text{ dB}$ $I_{or}(1) \quad \pm 0.7 \text{ dB}$ $I_{oc} \quad \pm 1.0 \text{ dB}$ <u>During T1 and T2:</u> $I_{or}(2) \text{ relative to } I_{or}(1) \pm 0.3 \text{ dB}$</p> <p>Assumptions: a) The contributing uncertainties for $I_{or}(n)$, channel power ratio, and I_{oc} are derived according to ETR 273-1-2 [4], with a coverage factor of $k=2$. b) Within each cell, the uncertainty for $I_{or}(n)$, and channel power ratio are uncorrelated to each other. c) The relative uncertainties for $I_{or}(n)$ across different cells may have any amount of positive correlation from zero (uncorrelated) to one (fully correlated). d) Across different cells, the channel power ratio uncertainties may have any amount of positive correlation from zero (uncorrelated) to one (fully correlated). e) The uncertainty for I_{oc} and $I_{or}(1)$ may have any amount of positive correlation from zero (uncorrelated) to one (fully correlated). f) The absolute uncertainty of $I_{or}(1)$ and the relative uncertainty of $I_{or}(2)$, are uncorrelated to each other.</p> <p>An explanation of correlation between uncertainties, and of the rationale behind the assumptions, is recorded in 3GPP TR 34 902 [24].</p>	
<p>8.6.1.6 Event triggered reporting of multiple neighbour cells in Case 3 fading condition</p>	<p><u>During T1 and T2:</u> $\frac{CPICH - E_c}{I_{or}} \quad \pm 0.1 \text{ dB}$ $I_{or}(1) \quad \pm 0.7 \text{ dB}$ $I_{oc} \quad \pm 1.0 \text{ dB}$ <u>During T1 and T2:</u> $I_{or}(2) \text{ relative to } I_{or}(1) \pm 0.3 \text{ dB}$</p>	

Clause	Maximum Test System Uncertainty	Derivation of Test System Uncertainty
	<p>Assumptions:</p> <p>a) The contributing uncertainties for $I_{or}(n)$, channel power ratio, and I_{oc} are derived according to ETR 273-1-2 [4], with a coverage factor of $k=2$.</p> <p>b) Within each cell, the uncertainty for $I_{or}(n)$, and channel power ratio are uncorrelated to each other.</p> <p>c) The relative uncertainties for $I_{or}(n)$ across different cells may have any amount of positive correlation from zero (uncorrelated) to one (fully correlated).</p> <p>d) Across different cells, the channel power ratio uncertainties may have any amount of positive correlation from zero (uncorrelated) to one (fully correlated).</p> <p>e) The uncertainty for I_{oc} and $I_{or}(1)$ may have any amount of positive correlation from zero (uncorrelated) to one (fully correlated).</p> <p>f) The absolute uncertainty of $I_{or}(1)$ and the relative uncertainty of $I_{or}(2)$, are uncorrelated to each other.</p> <p>An explanation of correlation between uncertainties, and of the rationale behind the assumptions, is recorded in 3GPP TR 34 902 [24].</p>	
8.6.2 FDD inter frequency measurements		
8.6.2.1 Correct reporting of neighbours in AWGN propagation condition (Release 5 and earlier)	<p>Channel 1 <u>during T0, T1 and T2:</u></p> $\frac{CPICH - E_c}{I_{or}} \quad \pm 0.1 \text{ dB}$ $I_{oc} \quad \pm 1.0 \text{ dB}$ $I_{or} (1) \quad \pm 0.7 \text{ dB}$ <p>Channel 1 <u>during T2:</u></p> $I_{or} (2) \text{ relative to } I_{or} (1) \pm 0.3 \text{ dB}$ <p>Channel 2 <u>during T0, T1 and T2:</u></p> $I_{oc} \quad \pm 1.0 \text{ dB}$ <p>Channel 2 <u>during T1 and T2:</u></p> $I_{or} (3) \quad \pm 0.7 \text{ dB}$ $\frac{CPICH - E_c}{I_{or}} \quad \pm 0.1 \text{ dB}$	

Clause	Maximum Test System Uncertainty	Derivation of Test System Uncertainty
	<p>Assumptions:</p> <p>a) The contributing uncertainties for $I_{or}(n)$, channel power ratio, and I_{oc} are derived according to ETR 273-1-2 [16], with a coverage factor of $k=2$.</p> <p>b) Within each cell, the uncertainty for $I_{or}(n)$, and channel power ratio are uncorrelated to each other.</p> <p>c) Across different cells, the channel power ratio uncertainties may have any amount of positive correlation from zero (uncorrelated) to one (fully correlated)</p> <p>d) The uncertainty for I_{oc} and $I_{or}(n)$ may have any amount of positive correlation from zero (uncorrelated) to one (fully correlated).</p> <p>e) The absolute uncertainty of $I_{or}(1)$ and the relative uncertainty of $I_{or}(2)$, are uncorrelated to each other.</p> <p>f) The absolute uncertainties for $I_{or}(1)$ and $I_{or}(3)$ may have any amount of positive correlation from zero (uncorrelated) to one (fully correlated).</p> <p>g) The absolute uncertainties for $I_{oc}(1)$ and $I_{oc}(2)$ may have any amount of positive correlation from zero (uncorrelated) to one (fully correlated).</p> <p>An explanation of correlation between uncertainties, and of the rationale behind the assumptions, is recorded in 3GPP TR 34 902 [24].</p>	
8.6.2.1 Correct reporting of neighbours in AWGN propagation condition (Release 6 and later)	Same as 8.2.2.1	Same as 8.2.2.1
8.6.2.2 Correct reporting of neighbours in Fading propagation condition (Release 5 only)	<p><u>Channel 1 during T1 and T2:</u></p> $\frac{CPICH - E_c}{I_{or}} \quad \pm 0.1 \text{ dB}$ $I_{or}(1) \quad \pm 0.7 \text{ dB}$ $I_{oc}(1) \quad \pm 1.0 \text{ dB}$ <p><u>Channel 2 during T1 and T2:</u></p> $I_{oc}(2) \quad \pm 1.0 \text{ dB}$ <p><u>Channel 2 during T2:</u></p> $\frac{CPICH - E_c}{I_{or}} \quad \pm 0.1 \text{ dB}$ $I_{or}(2) \quad \pm 0.7 \text{ dB}$	

Clause	Maximum Test System Uncertainty	Derivation of Test System Uncertainty
	Assumptions: a) The contributing uncertainties for $I_{or}(n)$, channel power ratio, and I_{oc} are derived according to ETR 273-1-2 [16], with a coverage factor of $k=2$. b) Within each cell, the uncertainty for $I_{or}(n)$, and channel power ratio are uncorrelated to each other. c) Across different cells, the channel power ratio uncertainties may have any amount of positive correlation from zero (uncorrelated) to one (fully correlated). d) The uncertainty for $I_{oc}(n)$ and $I_{or}(n)$ may have any amount of positive correlation from zero (uncorrelated) to one (fully correlated). e) The absolute uncertainties for $I_{or}(1)$ and $I_{or}(2)$ may have any amount of positive correlation from zero (uncorrelated) to one (fully correlated). f) The absolute uncertainties for $I_{oc}(1)$ and $I_{oc}(2)$ may have any amount of positive correlation from zero (uncorrelated) to one (fully correlated). An explanation of correlation between uncertainties, and of the rationale behind the assumptions, is recorded in 3GPP TR 34 902 [24].	
8.6.2.2A Correct reporting of neighbours in Fading propagation condition (Release 6 and later)	Same as 8.6.2.2	Same as 8.6.2.2
8.6.2.3 Correct reporting of neighbours in Fading propagation condition using TGL1=14	Channel 1 during T1 and T2: $\frac{CPICH - E_c}{I_{or}} \quad \pm 0.1 \text{ dB}$ $I_{or}(1) \quad \pm 0.7 \text{ dB}$ $I_{oc}(1) \quad \pm 1.0 \text{ dB}$ Channel 2 during T1 and T2: $I_{oc}(2) \quad \pm 1.0 \text{ dB}$ Channel 2 during T2: $\frac{CPICH - E_c}{I_{or}} \quad \pm 0.1 \text{ dB}$ $I_{or}(2) \quad \pm 0.7 \text{ dB}$	

Clause	Maximum Test System Uncertainty	Derivation of Test System Uncertainty
	Assumptions: a) The contributing uncertainties for $I_{or}(n)$, channel power ratio, and I_{oc} are derived according to ETR 273-1-2 [16], with a coverage factor of $k=2$. b) Within each cell, the uncertainty for $I_{or}(n)$, and channel power ratio are uncorrelated to each other. c) Across different cells, the channel power ratio uncertainties may have any amount of positive correlation from zero (uncorrelated) to one (fully correlated). d) The uncertainty for $I_{oc}(n)$ and $I_{or}(n)$ may have any amount of positive correlation from zero (uncorrelated) to one (fully correlated). e) The absolute uncertainties for $I_{or}(1)$ and $I_{or}(2)$ may have any amount of positive correlation from zero (uncorrelated) to one (fully correlated). f) The absolute uncertainties for $I_{oc}(1)$ and $I_{oc}(2)$ may have any amount of positive correlation from zero (uncorrelated) to one (fully correlated).	
8.6.3 TDD measurements		
8.6.3.1 Correct reporting of TDD neighbours in AWGN propagation condition	TBD	
8.6.4 GSM Measurement		
8.6.4.1 Correct reporting of GSM neighbours in AWGN propagation condition	\hat{I}_{or}/I_{oc} ± 0.3 dB $I_{oc}/RXLEV$ ± 0.5 dB I_{oc} ± 1.0 dB RXLEV ± 1.0 dB $\frac{CPICH - E_c}{I_{or}}$ ± 0.1 dB	0.1 dB uncertainty in CPICH_Ec ratio 0.3 dB uncertainty in \hat{I}_{or}/I_{oc} based on power meter measurement after the combiner 0.5 dB uncertainty in $I_{oc}/RXLEV$ based on power meter measurement after the combiner The absolute error of the AWGN is specified as 1.0 dB. The absolute error of the RXLEV is specified as 1.0 dB.
8.6.5 Combined Interfrequency and GSM measurements		

Clause	Maximum Test System Uncertainty	Derivation of Test System Uncertainty
<p>8.6.5.1 Correct reporting of neighbours in AWGN propagation condition</p>	<p><u>Channel 1 during T0 to T5:</u> $\frac{CPICH - E_c}{I_{or}} \quad \pm 0.1 \text{ dB}$ $I_{or} (1) \quad \pm 0.7 \text{ dB}$ $I_{oc} (1) \quad \pm 1.0 \text{ dB}$ $\hat{I}_{or} / I_{oc} \quad \pm 0.3 \text{ dB}$ <u>Channel 1 during T2 to T5:</u> $I_{or} (2) \text{ relative to } I_{or} (1) \pm 0.3 \text{ dB}$ <u>Channel 2 during T0 to T5:</u> $I_{oc} (2) \quad \pm 1.0 \text{ dB}$ <u>Channel 2 during T2 to T5:</u> $\frac{CPICH - E_c}{I_{or}} \quad \pm 0.1 \text{ dB}$ $I_{or} (2) \quad \pm 0.7 \text{ dB}$ $\hat{I}_{or} / I_{oc} \quad \pm 0.3 \text{ dB}$ <u>GSM during T4/T5</u> $I_{oc} / RXLEV \quad \pm 0.5 \text{ dB}$ $RXLEV \quad \pm 1.0 \text{ dB}$</p>	<p>0.3 dB uncertainty in \hat{I}_{or} / I_{oc} based on power meter measurement after the combiner</p> <p>0.5 dB uncertainty in loc/RXLEV based on power meter measurement after the combiner</p> <p>The absolute error of the AWGN is specified as 1.0 dB.</p> <p>The absolute error of the RXLEV is specified as 1.0 dB.</p>
	<p>Assumptions:</p> <p>a) The contributing uncertainties for lor(n), channel power ratio, and loc are derived according to ETR 273-1-2 [16], with a coverage factor of k=2.</p> <p>b) Within each cell, the uncertainty for lor(n), and channel power ratio are uncorrelated to each other.</p> <p>c) Across different cells, the channel power ratio uncertainties may have any amount of positive correlation from zero (uncorrelated) to one (fully correlated).</p> <p>d) The uncertainty for loc(n) and lor(n) may have any amount of positive correlation from zero (uncorrelated) to one (fully correlated).</p> <p>e) The absolute uncertainties for lor(1) and lor(2) may have any amount of positive correlation from zero (uncorrelated) to one (fully correlated).</p> <p>f) The absolute uncertainties for loc(1) and loc(2) may have any amount of positive correlation from zero (uncorrelated) to one (fully correlated).</p> <p>An explanation of correlation between uncertainties, and of the rationale behind the assumptions, is recorded in 3GPP TR 34 902 [24].</p>	
<p>8.7 Measurements Performance Requirements</p>		
<p>8.7.1 CPICH RSCP</p>		
<p>8.7.1.1 Intra frequency measurements accuracy</p>	$\hat{I}_{or} / I_{oc} \quad \pm 0.3 \text{ dB}$ $I_{oc} \quad \pm 1.0 \text{ dB}$ $\frac{CPICH - E_c}{I_{or}} \quad \pm 0.1 \text{ dB}$	<p>Same as 8.2.2.1</p>

Clause	Maximum Test System Uncertainty	Derivation of Test System Uncertainty
8.7.1.2 Inter frequency measurement accuracy	\hat{I}_{or}/I_{oc} ± 0.3 dB I_{oc} ± 1.0 dB I_{oc1}/I_{oc2} ± 0.3 dB $\frac{CPICH - E_c}{I_{or}}$ ± 0.1 dB	Same as 8.2.2.2
8.7.2 CPICH Ec/Io		
8.7.2.1 Intra frequency measurements accuracy	\hat{I}_{or}/I_{oc} ± 0.3 dB I_{oc} ± 1.0 dB $\frac{CPICH - E_c}{I_{or}}$ ± 0.1 dB	Same as 8.2.2.1
8.7.2.2 Inter frequency measurement accuracy	\hat{I}_{or}/I_{oc} ± 0.3 dB I_{oc} ± 1.0 dB I_{oc1}/I_{oc2} ± 0.3 dB $\frac{CPICH - E_c}{I_{or}}$ ± 0.1 dB	Same as 8.2.2.2
8.7.3.1 UTRA Carrier RSSI, absolute measurement accuracy	\hat{I}_{or}/I_{oc} ± 0.3 dB I_{oc} ± 1.0 dB I_{oc1}/I_{oc2} ± 0.3 dB	<p>0.3 dB uncertainty in \hat{I}_{or}/I_{oc} based on power meter measurement after the combiner</p> <p>0.3 dB uncertainty in I_{oc1}/I_{oc2} based on power meter measurement after the combiner</p> <p>The absolute error of the AWGN is specified as 1.0 dB</p>
8.7.3.2 UTRA Carrier RSSI, relative measurement accuracy	\hat{I}_{or}/I_{oc} ± 0.3 dB I_{oc} ± 1.0 dB I_{oc2}/I_{oc3} ± 0.3 dB	<p>0.3 dB uncertainty in \hat{I}_{or}/I_{oc} based on power meter measurement after the combiner</p> <p>0.3 dB uncertainty in I_{oc2}/I_{oc3} based on power meter measurement after the combiner</p> <p>The absolute error of the AWGN is specified as 1.0 dB</p>

Clause	Maximum Test System Uncertainty	Derivation of Test System Uncertainty
8.7.3A GSM Carrier RSSI	\hat{I}_{or}/I_{oc} ± 0.3 dB $I_{oc}/RXLEV$ ± 0.5 dB I_{oc} ± 1.0 dB $\frac{CPICH - E_c}{I_{or}}$ ± 0.1 dB RXLEV ± 1.0 dB RXLEV1/RXLEV2 ± 1.4 dB	0.1 dB uncertainty in CPICH_Ec ratio 0.3 dB uncertainty in \hat{I}_{or}/I_{oc} based on power meter measurement after the combiner 0.5 dB uncertainty in loc/RXLEV based on power meter measurement after the combiner The absolute error of the AWGN is specified as 1.0 dB. The absolute error of the RXLEV is specified as 1.0 dB. The relative accuracy of RXLEV1 to RXLEV2 is specified to be 1.4 dB (RMS of individual uncertainties) when BCCHs are on the same or on different RF channel within the same frequency band The relative accuracy of RXLEV1 to RXLEV2 is specified to be 1.4 dB (RMS of individual uncertainties) when BCCHs are on different frequency band
8.7.3C UE Transmitted power (R99 and Rel-4 only)	Mean power measurement $\pm 0,7$ dB	Downlink parameters are unimportant.
8.7.3D UE Transmitted power (Rel-5 and later)	Mean power measurement $\pm 0,7$ dB	Downlink parameters are unimportant.
8.7.4 SFN-CFN observed time difference		
8.7.4.1 Intra frequency measurements accuracy	\hat{I}_{or}/I_{oc} ± 0.3 dB I_{oc} ± 1.0 dB Actual SFN-CFN observed time difference: ± 0.5 chips	0.3 dB uncertainty in \hat{I}_{or}/I_{oc} based on power meter measurement after the combiner The absolute error of the AWGN is specified as 1.0 dB
8.7.4.2 Inter frequency measurements accuracy	\hat{I}_{or}/I_{oc} ± 0.3 dB I_{oc} ± 1.0 dB Actual SFN-CFN observed time difference: ± 0.5 chips	0.3 dB uncertainty in \hat{I}_{or}/I_{oc} based on power meter measurement after the combiner The absolute error of the AWGN is specified as 1.0 dB
8.7.5.1 SFN-SFN observed time difference type 1	\hat{I}_{or}/I_{oc} ± 0.3 dB I_{oc} ± 1.0 dB Actual SFN-SFN observed time difference type 1: ± 0.5 chips	0.3 dB uncertainty in \hat{I}_{or}/I_{oc} based on power meter measurement after the combiner The absolute error of the AWGN is specified as 1.0 dB

Clause	Maximum Test System Uncertainty	Derivation of Test System Uncertainty
8.7.6 UE Rx-Tx time difference	\hat{I}_{or}/I_{oc} ± 0.3 dB I_{oc} ± 1.0 dB Rx-Tx Timing Accuracy ± 0.5 chip	0.3 dB uncertainty in \hat{I}_{or}/I_{oc} based on power meter measurement after the combiner The absolute error of the AWGN is specified as 1.0 dB.
8.7.8 P-CCPCH RSCP	TBD	
8.7.9 UE Transmission Power Headroom	$\frac{E_c}{I_{or}}$ ± 0.1 dB Overall UL absolute power measurement uncertainty ± 0.7 dB DPCCH code domain absolute power measurement uncertainty ± 0.8 dB	0.1 dB uncertainty in E_c/I_{or} ratio Absolute power uncertainty (all codes together) ± 0.7 dB, relative code domain power uncertainty ± 0.3 dB, These are uncorrelated so can be combined RSS. Overall error is $(0.3^2 + 0.7^2)^{0.5}$ = 0.8 dB,

F.1.6 Performance requirement (HSDPA)

Table F.1.6: Maximum Test System Uncertainty for Performance Requirements (HSDPA)

Clause	Maximum Test System Uncertainty	Derivation of Test System Uncertainty
9.2.1A to 9.2.1G Single Link Performance	\hat{I}_{or}/I_{oc} ± 0.6 dB I_{oc} ± 1.0 dB $\frac{E_c}{I_{or}}$ ± 0.1 dB	<p>0.1 dB uncertainty in E_c/I_{or} ratio</p> <p>Worst case gain uncertainty due to the fader from the calibrated static profile is ± 0.5 dB per output</p> <p>In addition the same ± 0.3 dB \hat{I}_{or}/I_{oc} ratio error as 7.2.</p> <p>These are uncorrelated so can be RSS.</p> <p>Overall error in \hat{I}_{or}/I_{oc} is $(0.5^2 + 0.3^2)^{0.5} = 0.6$ dB</p>
9.2.2A to 9.2.2D Open loop diversity performance	\hat{I}_{or}/I_{oc} ± 0.8 dB I_{oc} ± 1.0 dB $\frac{E_c}{I_{or}}$ ± 0.1 dB	<p>Worst case gain uncertainty due to the fader from the calibrated static profile is ± 0.5 dB per output</p> <p>In addition the same ± 0.3 dB \hat{I}_{or}/I_{oc} ratio error as 7.2.</p> <p>These are uncorrelated so can be RSS.</p> <p>Overall error in \hat{I}_{or}/I_{oc} is $(0.5^2 + 0.5^2 + 0.3^2)^{0.5} = 0.768$ dB. Round up to 0.8 dB</p>
9.2.3A to 9.2.3D Closed loop diversity performance	Same as 9.2.2A	Same as 9.2.2A
9.3.1 Single Link Performance - AWGN propagation conditions	\hat{I}_{or}/I_{oc} ± 0.3 dB I_{oc} ± 1.0 dB $\frac{E_c}{I_{or}}$ ± 0.1 dB	<p>0.1 dB uncertainty in DPCH_ Ec/Ior ratio</p> <p>0.3 dB uncertainty in \hat{I}_{or}/I_{oc} based on power meter measurement after the combiner</p> <p>Overall error is the sum of the \hat{I}_{or}/I_{oc} ratio error and the DPCH_ Ec/Ior ratio but is not RSS for simplicity. The absolute error of the AWGN Ioc is not important for any tests in clause 7 but is specified as 1.0 dB.</p>

Clause	Maximum Test System Uncertainty	Derivation of Test System Uncertainty
9.3.2 Single Link Performance - Fading propagation conditions	\hat{I}_{or}/I_{oc} ± 0.6 dB I_{oc} ± 1.0 dB $\frac{E_c}{I_{or}}$ ± 0.1 dB	<p>0.1 dB uncertainty in E_c/I_{or} ratio</p> <p>Worst case gain uncertainty due to the fader from the calibrated static profile is ± 0.5 dB per output</p> <p>In addition the same ± 0.3 dB \hat{I}_{or}/I_{oc} ratio error as 7.2.</p> <p>These are uncorrelated so can be RSS.</p> <p>Overall error in \hat{I}_{or}/I_{oc} is $(0.5^2 + 0.3^2)^{0.5} = 0.6$ dB</p>
9.3.3 Open Loop Diversity Performance - AWGN propagation conditions	\hat{I}_{or}/I_{oc} ± 0.5 dB I_{oc} ± 1.0 dB $\frac{E_c}{I_{or}}$ ± 0.1 dB	<p>0.3 dB uncertainty in \hat{I}_{or}/I_{oc} for each antenna output based on power meter measurement after the combiner</p> <p>In addition the same ± 0.3 dB \hat{I}_{or}/I_{oc} ratio error as 7.2.</p> <p>These are uncorrelated so can be RSS.</p> <p>Overall error in \hat{I}_{or}/I_{oc} is $(0.3^2 + 0.3^2)^{0.5} = 0.424$ dB. Round up to 0.5 dB</p>
9.3.4 Open Loop Diversity Performance - Fading propagation conditions	\hat{I}_{or}/I_{oc} ± 0.8 dB I_{oc} ± 1.0 dB $\frac{E_c}{I_{or}}$ ± 0.1 dB	<p>In addition the same ± 0.3 dB \hat{I}_{or}/I_{oc} ratio error as 7.2.</p> <p>These are uncorrelated so can be RSS.</p> <p>Overall error in \hat{I}_{or}/I_{oc} is $(0.5^2 + 0.5^2 + 0.3^2)^{0.5} = 0.768$ dB. Round up to 0.8 dB</p>
9.3.5 Closed Loop Diversity Performance - AWGN propagation conditions	Same as 9.3.3	
9.3.6 Closed Loop Diversity Performance - Fading propagation conditions	Same as 9.3.4	
9.4.1 Single link Performance	\hat{I}_{or}/I_{oc} ± 0.6 dB I_{oc} ± 1.0 dB $\frac{E_c}{I_{or}}$ ± 0.1 dB	<p>0.1 dB uncertainty in E_c/I_{or} ratio</p> <p>Worst case gain uncertainty due to the fader from the calibrated static profile is ± 0.5 dB per output</p> <p>In addition the same ± 0.3 dB \hat{I}_{or}/I_{oc} ratio error as 7.2.</p> <p>These are uncorrelated so can be RSS.</p> <p>Overall error in \hat{I}_{or}/I_{oc} is $(0.5^2 + 0.3^2)^{0.5} = 0.6$ dB</p>

Clause	Maximum Test System Uncertainty	Derivation of Test System Uncertainty
9.4.1A Single link Performance – Enhanced Performance Requirements Type 1	Same as 9.4.1	Same as 9.4.1
9.4.2 Open loop diversity performance	\hat{I}_{or}/I_{oc} ± 0.8 dB I_{oc} ± 1.0 dB $\frac{E_c}{I_{or}}$ ± 0.1 dB	<p>Worst case gain uncertainty due to the fader from the calibrated static profile is ± 0.5 dB per output</p> <p>In addition the same ± 0.3 dB \hat{I}_{or}/I_{oc} ratio error as 7.2.</p> <p>These are uncorrelated so can be RSS.</p> <p>Overall error in \hat{I}_{or}/I_{oc} is $(0.52 + 0.52 + 0.32) 0.5 = 0.768$ dB. Round up to 0.8 dB</p>
9.4.2A Open loop diversity performance – Enhanced Performance Requirements Type 1	Same as 9.4.2	Same as 9.4.2

F.1.7 Performance requirement (E-DCH)

Table F.1.7: Maximum Test System Uncertainty for Performance Requirements (E-DCH)

Clause	Maximum Test System Uncertainty	Derivation of Test System Uncertainty
10.2.1.1 Detection of E-DCH HARQ ACK Indicator Channel (E-HICH) Single Link Performance (10 ms TTI)	\hat{I}_{or}/I_{oc} ± 0.6 dB I_{oc} ± 1.0 dB E-HICH_Ec/lor ± 0.1 dB	<p>0.1 dB uncertainty in Ec/Ior ratio</p> <p>Worst case gain uncertainty due to the fader from the calibrated static profile is ± 0.5 dB per output</p> <p>In addition the same ± 0.3 dB \hat{I}_{or}/I_{oc} ratio error as 7.2.</p> <p>These are uncorrelated so can be RSS.</p> <p>Overall error in \hat{I}_{or}/I_{oc} is $(0.5^2 + 0.3^2)^{0.5} = 0.6$ dB</p>
10.2.1.1A Detection of E-DCH HARQ ACK Indicator Channel (E-HICH) Single Link Performance (10 ms TTI, Type 1)	\hat{I}_{or}/I_{oc} ± 0.6 dB I_{oc} ± 1.0 dB E-HICH_Ec/lor ± 0.1 dB	<p>0.1 dB uncertainty in Ec/Ior ratio</p> <p>Worst case gain uncertainty due to the fader from the calibrated static profile is ± 0.5 dB per output</p> <p>In addition the same ± 0.3 dB \hat{I}_{or}/I_{oc} ratio error as 7.2.</p> <p>These are uncorrelated so can be RSS.</p> <p>Overall error in \hat{I}_{or}/I_{oc} is $(0.5^2 + 0.3^2)^{0.5} = 0.6$ dB</p>
10.2.1.2 Detection of E-DCH HARQ ACK Indicator Channel (E-HICH) Single Link Performance (2 ms TTI)	Same as in 10.2.1.1	Same as 10.2.1.1
10.2.1.2A Detection of E-DCH HARQ ACK Indicator Channel (E-HICH) Single Link Performance (2 ms TTI, Type 1)	Same as in 10.2.1.1	Same as 10.2.1.1
10.2.2.1.1 Detection of E-DCH HARQ ACK Indicator Channel (E-HICH) in Inter-Cell handover conditions – RLS not containing the serving E-DCH cell (10 ms TTI)	\hat{I}_{or1}/I_{oc} ± 0.6 dB \hat{I}_{or2}/I_{oc} ± 0.6 dB I_{oc} ± 1.0 dB E-HICH_Ec/lor ± 0.1 dB	<p>Worst case gain uncertainty due to the fader from the calibrated static profile is ± 0.5 dB per output</p> <p>In addition the same ± 0.3 dB \hat{I}_{or}/I_{oc} ratio error as 7.2.</p> <p>These are uncorrelated so can be RSS.</p> <p>Overall error per \hat{I}_{or1}/I_{oc} or \hat{I}_{or2}/I_{oc} is $(0.5^2 + 0.3^2)^{0.5} = 0.6$ dB.</p>
10.2.2.1.1A Detection of E-DCH HARQ ACK Indicator Channel (E-HICH) in Inter-Cell handover conditions – RLS not containing the serving E-DCH cell (10 ms TTI, Type 1)	\hat{I}_{or1}/I_{oc} ± 0.6 dB \hat{I}_{or2}/I_{oc} ± 0.6 dB I_{oc} ± 1.0 dB E-HICH_Ec/lor ± 0.1 dB	<p>Worst case gain uncertainty due to the fader from the calibrated static profile is ± 0.5 dB per output</p> <p>In addition the same ± 0.3 dB \hat{I}_{or}/I_{oc} ratio error as 7.2.</p> <p>These are uncorrelated so can be RSS.</p> <p>Overall error per \hat{I}_{or1}/I_{oc} or \hat{I}_{or2}/I_{oc} is $(0.5^2 + 0.3^2)^{0.5} = 0.6$ dB.</p>

Clause	Maximum Test System Uncertainty	Derivation of Test System Uncertainty
10.2.2.1.2 Detection of E-DCH HARQ ACK Indicator Channel (E-HICH) in Inter-Cell handover conditions – RLS not containing the serving E-DCH cell (2 ms TTI)	Same as 10.2.2.1.1	Same as 10.2.2.1.1
10.2.2.1.2A Detection of E-DCH HARQ ACK Indicator Channel (E-HICH) in Inter-Cell handover conditions – RLS not containing the serving E-DCH cell (2 ms TTI, Type 1)	Same as 10.2.2.1.1	Same as 10.2.2.1.1
10.2.2.2.1 Detection of E-DCH HARQ ACK Indicator Channel (E-HICH) in Inter-Cell handover conditions – RLS containing the serving E-DCH cell (10 ms TTI)	Same as 10.2.2.1.1	Same as 10.2.2.1.1
10.2.2.2.1A Detection of E-DCH HARQ ACK Indicator Channel (E-HICH) in Inter-Cell handover conditions – RLS containing the serving E-DCH cell (10 ms TTI, Type 1)	Same as 10.2.2.1.1	Same as 10.2.2.1.1
10.2.2.2.2 Detection of E-DCH HARQ ACK Indicator Channel (E-HICH) in Inter-Cell handover conditions – RLS containing the serving E-DCH cell (2 ms TTI)	Same as 10.2.2.1.1	Same as 10.2.2.1.1
10.2.2.2.2A Detection of E-DCH HARQ ACK Indicator Channel (E-HICH) in Inter-Cell handover conditions – RLS containing the serving E-DCH cell (2 ms TTI, Type 1)	Same as 10.2.2.1.1	Same as 10.2.2.1.1
10.3.1.1 Detection of E-DCH Relative Grant Channel (E-RGCH) Single Link Performance (10 ms TTI)	\hat{I}_{or}/I_{oc} ± 0.6 dB I_{oc} ± 1.0 dB E-RGCH_Ec/Ior ± 0.1 dB	Same as 10.2.1.1
10.3.1.1A Detection of E-DCH Relative Grant Channel (E-RGCH) Single Link Performance (10 ms TTI, Type 1)	\hat{I}_{or}/I_{oc} ± 0.6 dB I_{oc} ± 1.0 dB E-RGCH_Ec/Ior ± 0.1 dB	Same as 10.2.1.1
10.3.1.2 Detection of E-DCH Relative Grant Channel (E-RGCH) Single Link Performance (2 ms TTI)	Same as 10.3.1.1	Same as in 10.2.1.1
10.3.1.2A Detection of E-DCH Relative Grant Channel (E-RGCH) Single Link Performance (2 ms TTI, Type 1)	Same as 10.3.1.1	Same as in 10.2.1.1
10.3.2 Detection of E-DCH Relative Grant Channel (E-RGCH) in Inter-Cell Handover conditions	\hat{I}_{or1}/I_{oc} ± 0.6 dB \hat{I}_{or2}/I_{oc} ± 0.6 dB I_{oc} ± 1.0 dB E-RGCH_Ec/Ior ± 0.1 dB	Same as 10.2.2.1.1
10.3.2A Detection of E-DCH Relative Grant Channel (E-RGCH) in Inter-Cell Handover conditions (Type 1)	\hat{I}_{or1}/I_{oc} ± 0.6 dB \hat{I}_{or2}/I_{oc} ± 0.6 dB I_{oc} ± 1.0 dB E-RGCH_Ec/Ior ± 0.1 dB	Same as 10.2.2.1.1
10.4.1 Demodulation of E-DCH Absolute Grant Channel (E-AGCH) Single Link Performance	\hat{I}_{or}/I_{oc} ± 0.6 dB I_{oc} ± 1.0 dB E-AGCH_Ec/Ior ± 0.1 dB	Same as 10.2.1.1

Clause	Maximum Test System Uncertainty	Derivation of Test System Uncertainty
10.4.1A Demodulation of E-DCH Absolute Grant Channel (E-AGCH) Single Link Performance (Type 1)	\hat{I}_{or}/I_{oc} ± 0.6 dB I_{oc} ± 1.0 dB E-AGCH_Ec/Ior ± 0.1 dB	Same as 10.2.1.1

F.1.8 Performance requirement (MBMS)

Table F.1.8: Maximum Test System Uncertainty for Performance Requirements (MBMS)

Clause	Maximum Test System Uncertainty	Derivation of Test System Uncertainty
11.3 Demodulation of MTCH and cell identification	S-CCPCH_Ec/Ior ± 0.1 dB I_{oc} ± 1.0 dB \hat{I}_{or1}/I_{oc} ± 0.6 dB \hat{I}_{or2}/I_{oc} ± 0.6 dB \hat{I}_{or3}/I_{oc} ± 0.6 dB	0.1 dB uncertainty in S-CCPCH_Ec/Ior ratio Worst case gain uncertainty due to the fader from the calibrated static profile is ± 0.5 dB per output. In addition the same ± 0.3 dB \hat{I}_{or}/I_{oc} ratio error as 7.2. These are uncorrelated so can be RSS. Overall error in \hat{I}_{or}/I_{oc} is $(0.5^2 + 0.5^2 + 0.5^2 + 0.3^2)^{0.5} = 1.0$ dB, but per output \hat{I}_{or1}/I_{oc} , \hat{I}_{or2}/I_{oc} or \hat{I}_{or3}/I_{oc} the error is $(0.5^2 + 0.3^2)^{0.5} = 0.6$ dB.

F.2 Test Tolerances (This clause is informative)

The Test Tolerances defined in this clause have been used to relax the Minimum Requirements in the present document to derive the Test Requirements.

The Test Tolerances are derived from Test System uncertainties, regulatory requirements and criticality to system performance. As a result, the Test Tolerances may sometimes be set to zero.

The test tolerances should not be modified for any reason e.g. to take account of commonly known test system errors (such as mismatch, cable loss, etc.).

F.2.1 Transmitter

Table F.2.1: Test Tolerances for transmitter tests.

Clause	Test Tolerance
5.2 Maximum Output Power	0.7 dB
5.2A Maximum Output Power with HS-DPCCH (Release 5 only)	0.7 dB
5.2AA Maximum Output Power with HS-DPCCH (Release 6 and later)	0.7 dB
5.2B Maximum Output Power with HS-DPCCH and E-DCH	0.7 dB
5.2C UE relative code domain power accuracy	For 0 dB \geq -10 dB CDP 0.2 dB For -10 dB \geq -15 dB CDP 0.3 dB For -15 dB \geq -20 dB CDP 0.4 dB
5.2D UE Relative Code Domain Power Accuracy with HS-DPCCH and E-DCH	For 0 dB \geq -10 dB CDP 0.2 dB For -10 dB \geq -15 dB CDP 0.3 dB For -15 dB \geq -20 dB CDP 0.4 dB
5.3 Frequency error	10 Hz
5.4.1 Open loop power control in uplink	1.0 dB
5.4.2 Inner loop power control in the uplink	0.1 dB (1 dB and 0 dB range) 0.15 dB (2 dB range) 0.2 dB (3 dB range) 0.3 dB (> 3 dB range))
5.4.3 Minimum Output Power	1.0 dB
5.4.4 Out-of-synchronisation handling of output power: $\frac{DPCCH_E_c}{I_{or}}$	0.4 dB
5.4.4 Out-of-synchronisation handling of output power: transmit ON/OFF time	0 ms
5.5.1 Transmit OFF power	1.0 dB
5.5.2 Transmit ON/OFF time mask (dynamic case)	On power +0.7 dB / -1.0 dB Off power TT 1.0 dB
5.6 Change of TFC: power control step size	0.3 dB
5.7 Power setting in uplink compressed mode:-UE output power	See subset of 5.4.2
5.7A HS-DPCCH	0.1 dB (1 dB and 0 dB range) 0.15 dB (2 dB range) 0.2 dB (3 dB range) 0.3 dB (> 3 dB range)
5.8 Occupied Bandwidth	0 kHz
5.9 Spectrum emission mask	1.5 dB (0 dB for additional requirements for Band II, Band IV, Band V and Band X only)
5.9A Spectrum emission mask with HS-DPCCH	1.5 dB (0 dB for additional requirements for Band II, Band IV, Band V and Band X only)
5.9B Spectrum emission mask with E-DCH	1.5 dB (0 dB for additional requirements for Band II, Band IV and Band V only)
5.10 ACLR	0.8 dB for ratio 0.0 dB for absolute power
5.10A ACLR with HS-DPCCH	0.8 dB for ratio 0.0 dB for absolute power

Clause	Test Tolerance
5.10B ACLR with E-DCH	0.8 dB for ratio 0.0 dB for absolute power
5.11 Spurious emissions	0 dB
5.12 Transmit Intermodulation	0 dB
5.13.1 Transmit modulation: EVM	0%
5.13.1A Transmit modulation: EVM with HS-DPCCH	0%
5.13.1AA Transmit modulation: EVM and phase discontinuity with HS-DPCCH	0% EVM 6 degrees phase discontinuity
5.13.2 Transmit modulation: peak code domain error	1.0 dB
5.13.2A Relative Code Domain Error	±0.5 dB
5.13.2B Relative Code Domain Error with HS-DPCCH and E-DCH	±0.5 dB
5.13.3 UE phase discontinuity	0% for EVM
	10 Hz for Frequency error
	6 degree for Phase discontinuity
5.13.4 PRACH preamble quality (EVM)	0%
5.13.4 PRACH preamble quality (Frequency error)	10 Hz

F.2.2 Receiver

Table F.2.2: Test Tolerances for receiver tests.

Clause	Test Tolerance
6.2 Reference sensitivity level	0.7 dB
6.3 Maximum input level:	0.7 dB for Ior
6.3A Maximum Input Level for HS-PDSCH Reception (16QAM)	0.7 dB for Ior
6.4 Adjacent channel selectivity (Rel-99 and Rel-4)	0 dB
6.4A Adjacent channel selectivity (Rel-5 and later releases)	0 dB
6.5 Blocking characteristics	0 dB
6.6 Spurious Response	0 dB
6.7 Intermodulation Characteristics	0 dB
6.8 Spurious emissions	0 dB

F.2.3 Performance requirements

Table F.2.3: Test Tolerances for Performance Requirements.

Clause	Test Tolerance
7.2 Demodulation in Static Propagation Condition	0.3 dB for \hat{I}_{or}/I_{oc} 0.1 dB for DPCH_Ec/lor
7.3 Demodulation of DCH in multipath Fading Propagation conditions	0.6 dB for \hat{I}_{or}/I_{oc} 0.1 dB for DPCH_Ec/lor
7.4 Demodulation of DCH in Moving Propagation conditions	0.6 dB for \hat{I}_{or}/I_{oc} 0.1 dB for DPCH_Ec/lor
7.5 Demodulation of DCH in Birth-Death Propagation conditions	0.6 dB for \hat{I}_{or}/I_{oc} 0.1 dB for DPCH_Ec/lor
7.5A Demodulation of DCH in high speed train conditions	0.6 dB for \hat{I}_{or}/I_{oc} 0.1 dB for DPCH_Ec/lor
7.6.1 Demodulation of DCH in open loop Transmit diversity mode	0.8 dB for \hat{I}_{or}/I_{oc} 0.1 dB for DPCH_Ec/lor
7.6.2 Demodulation of DCH in closed loop Transmit diversity mode	0.8 dB for \hat{I}_{or}/I_{oc} 0.1 dB for DPCH_Ec/lor
7.6.3, Demodulation of DCH in site selection diversity Transmission power control mode	0.8 dB for \hat{I}_{or}/I_{oc} 0.1 dB for DPCH_Ec/lor
7.7.1 Demodulation in inter-cell soft Handover conditions (Release 5 and earlier)	0.6 dB for \hat{I}_{or1}/I_{oc} and \hat{I}_{or2}/I_{oc} 0.1 dB for DPCH_Ec/lor
7.7.1A Demodulation in inter-cell soft Handover conditions (Release 6 and later)	0.6 dB for \hat{I}_{or1}/I_{oc} and \hat{I}_{or2}/I_{oc} 0.1 dB for DPCH_Ec/lor
7.7.2 Combining of TPC commands Test 1	0 dB for lor1, lor2 0.1 dB for DPCH_Ec/lor
7.7.2 Combining of TPC commands Test 2	0.8 dB for \hat{I}_{or}/I_{oc} 0.1 dB for DPCH_Ec/lor
7.7.3 Combining of reliable TPC commands from radio links of different radio link sets	Test parameters: 0 dB for \hat{I}_{or1}/I_{oc} 0 dB for \hat{I}_{or2}/I_{oc} 0 dB for \hat{I}_{or3}/I_{oc} 0 dB for DPCH_Ec1/lor1 0 dB for DPCH_Ec2/lor2 0 dB for DPCH_Ec3/lor3 Test requirements: 0 dB for Test 1 0 dB for Test 2
7.8.1 Power control in downlink constant BLER target	0.6 dB for \hat{I}_{or}/I_{oc} 0.1 dB for DPCH_Ec/lor For test cases wherein the SS response time to DL power control commands is delayed by one timeslot from the immediate response the following $\frac{DPCH_Ec}{I_{or}}$ test tolerances apply: Test 1: 0.4 dB for $\frac{DPCH_Ec}{I_{or}}$ Test 2: 0.3 dB for $\frac{DPCH_Ec}{I_{or}}$

Clause	Test Tolerance
7.8.2, Power control in downlink initial convergence	0.6 dB for measured DPCH_Ec/Ior power ratio values during T1 and T2. When the SS response time to DL power control commands is delayed by one timeslot from the immediate response the following measured DPCH_Ec/Ior power ratio value test tolerance applies: Test 1, 2, 3 and 4: 0.8 dB (= rounded 0.75 dB)
7.8.3, Power control in downlink: wind up effects	0.6 dB for \hat{I}_{or}/I_{oc} 0.1 dB for DPCH_Ec/Ior For test cases wherein the SS response time to DL power control commands is delayed by one timeslot from the immediate response the following $\frac{DPCH_Ec}{I_{or}}$ test tolerance applies: Test 1: 0.4 dB for $\frac{DPCH_Ec}{I_{or}}$
7.8.4, Power control in the downlink, different transport formats	0.6 dB for \hat{I}_{or}/I_{oc} 0.1 dB for DPCH_Ec/Ior For test cases where the SS response time to DL power control commands is delayed by one timeslot from the immediate response the following $\frac{DPCH_Ec}{I_{or}}$ test tolerances apply: Test 1 stage 1: 0.3 dB for $\frac{DPCH_Ec}{I_{or}}$ Test 1 stage 2: 0.2 dB for $\frac{DPCH_Ec}{I_{or}}$
7.9 Downlink compressed mode	0.6 dB for \hat{I}_{or}/I_{oc} 0.1 dB for DPCH_Ec/Ior
7.10 Blind transport format detection Tests 1, 2, 3	0.3 dB for \hat{I}_{or}/I_{oc} 0.1 dB for DPCH_Ec/Ior
7.10 Blind transport format detection Tests 4, 5, 6	0.6 dB for \hat{I}_{or}/I_{oc} 0.1 dB for DPCH_Ec/Ior
7.11 Demodulation of paging channel (PCH)	Test 1: 0.4 dB for \hat{I}_{or}/I_{oc}
	Test 2: 0.7 dB for \hat{I}_{or}/I_{oc}
7.12 Detection of acquisition indicator (AI)	0.4 dB for \hat{I}_{or}/I_{oc}

F.2.4 Requirements for support of RRM

Table F.2.4: Test Tolerances for Radio Resource Management Tests

Clause	Test Tolerance
8.2 Idle Mode Tasks	
8.2.2 Cell Re-Selection	
8.2.2.1 Scenario 1: Single carrier case	<p><u>During T1 and T2:</u> +0.60 dB for all Cell 1 and 2 Ec/Ior ratios -0.50 dB for all Cell 3, 4, 5, 6 Ec/Ior ratios +0.03 dB for Ior(3, 4, 5, 6)</p> <p><u>During T1:</u> -0.27 dB for Ior(1) +0.13 dB for Ior(2)</p> <p><u>During T2:</u> +0.13 dB for Ior(1) -0.27 dB for Ior(2)</p>
8.2.2.2 Scenario 2: Multi carrier case	<p><u>Channel 1 during T1 and T2:</u> +0.70 dB for all Cell 1 Ec/Ior ratios -0.80 dB for all Cell 3 and 4 Ec/Ior ratios</p> <p><u>Channel 1 during T1:</u> -0.01 dB for Ior(1) -0.01 dB for Ior(3, 4) No change for Ioc(1)</p> <p><u>Channel 1 during T2:</u> +0.75 dB for Ior(1) -0.05 dB for Ior(3, 4) -1.80 dB for Ioc(1)</p> <p><u>Channel 2 during T1 and T2:</u> +0.70 dB for all Cell 2 Ec/Ior ratios -0.80 dB for all Cell 5 and 6 Ec/Ior ratios</p> <p><u>Channel 2 during T1:</u> +0.75 dB for Ior(2) -0.05 dB for Ior(5, 6) -1.80 dB for Ioc(2)</p> <p><u>Channel 2 during T2:</u> -0.01 dB for Ior(2) -0.01 dB for Ior(5, 6) No change for Ioc(2)</p>
8.2.3 UTRAN to GSM Cell Re-Selection	
8.2.3.1 Scenario 1: Both UTRA and GSM level changed	<p>0.3 dB for \hat{I}_{or}/I_{oc} 0.1 dB for CPICH_Ec/Ior 1.0 dB for RXLEV</p>
8.2.3.2 Scenario 2: Only UTRA level changed	<p>0.3 dB for \hat{I}_{or}/I_{oc} 0.1 dB for CPICH_Ec/Ior 1.0 dB for RXLEV</p>
8.2.3.3 Scenario 3: HCS with only UTRA level changed	<p>0.3 dB for \hat{I}_{or}/I_{oc} 0.1 dB for CPICH_Ec/Ior 1.0 dB for RXLEV</p>
8.2.4 FDD/TDD cell re-selection	<p>0.3 dB for \hat{I}_{or}/I_{oc} 0.1 dB for CPICH_Ec/Ior 0.3 dB for Ioc1/Ioc2</p>
8.3 UTRAN Connected Mode Mobility	

Clause	Test Tolerance
8.3.1 FDD/FDD Soft Handover	<u>During T0/T1 and T2/T3/T4/T5/T6:</u> +0.70 dB for all Cell 1 Ec/Ior ratios Relative delay: {-147.5 ... +147.5} chips <u>During T0/T1:</u> Already covered above <u>During T2/T3/T4/T5/T6:</u> +0.70 dB for all Cell 2 Ec/Ior ratios
8.3.2 FDD/FDD Hard Handover	
8.3.2.1 Handover to intra-frequency cell	<u>During T1 and T2 / T3:</u> +0.70 dB for all Cell 1 Ec/Ior ratios <u>During T1:</u> Already covered above <u>During T2 / T3:</u> +0.70 dB for all Cell 2 Ec/Ior ratios
8.3.2.2 Handover to inter-frequency cell	<u>Channel 1 during T1 and T2 / T3:</u> +0.80 dB for all Cell 1 Ec/Ior ratios <u>Channel 2 during T1:</u> Not applicable <u>Channel 2 during T2 / T3:</u> +0.80 dB for all Cell 2 Ec/Ior ratios
8.3.3 FDD/TDD Handover	TBD
8.3.4 Inter-system Handover form UTRAN FDD to GSM	<u>During T2 and T3:</u> + 1 dB for RXLEV
8.3.5 Cell Re-selection in CELL_FACH	
8.3.5.1 One frequency present in the neighbour list	<u>During T1 and T2:</u> +0.60 dB for all Cell 1 and 2 Ec/Ior ratios -0.50 dB for all Cell 3, 4 ,5, 6 Ec/Ior ratios +0.03 dB for Ior(3, 4, 5, 6) <u>During T1:</u> -0.27 dB for Ior(1) +0.13 dB for Ior(2) <u>During T2:</u> +0.13 dB for Ior(1) -0.27 dB for Ior(2)

Clause	Test Tolerance
8.3.5.2 Two frequencies present in the neighbour list	<p><u>Channel 1 during T1 and T2:</u> +0.60 dB for all Cell 1 Ec/Ior ratios -0.70 dB for all Cell 3 and 4 Ec/Ior ratios</p> <p><u>Channel 1 during T1:</u> +0.05 dB for Ior(1) +0.05 dB for Ior(3, 4) No change for Ioc(1)</p> <p><u>Channel 1 during T2:</u> +0.75 dB for Ior(1) -0.05 dB for Ior(3, 4) -1.60 dB for Ioc(1)</p> <p><u>Channel 2 during T1 and T2:</u> +0.60 dB for all Cell 2 Ec/Ior ratios -0.70 dB for all Cell 5 and 6 Ec/Ior ratios</p> <p><u>Channel 2 during T1:</u> +0.75 dB for Ior(2) -0.05 dB for Ior(5, 6) -1.60 dB for Ioc(2)</p> <p><u>Channel 2 during T2:</u> +0.05 dB for Ior(2) +0.05 dB for Ior(5, 6) No change for Ioc(2)</p>
8.3.5.3 Cell Re-selection to GSM	<p>0.3 dB for \hat{I}_{or} / I_{oc} 0.1 dB for CPICH_Ec/Ior 1.0 dB for RXLEV</p>
8.3.6 Cell Re-selection in CELL_PCH	
8.3.6.1 One frequency present in the neighbour list	Same as 8.2.2.1
8.3.6.2 Two frequencies present in the neighbour list	Same as 8.2.2.2
8.3.6.3 Cell re-selection during an MBMS session, one UTRAN inter-frequency and 2 GSM cells present in the neighbour list	TBD
8.3.7 Cell Re-selection in URA_PCH	
8.3.7.1 One frequency present in the neighbour list	Same as 8.2.2.1
8.3.7.2 Two frequencies present in the neighbour list	Same as 8.2.2.2
8.3.8 Serving HS-DSCH cell change	<p><u>During T0/T1/T2/T3/T4:</u> +0.70 dB for all Cell 1 Ec/Ior ratios Relative delay: {-147.5 ... +147.5} chips <u>During T0</u> Already covered above</p> <p><u>During T1/T2/T3/T4</u> +0.70 dB for all Cell 2 Ec/Ior ratios</p>
8.4 RRC Connection Control	
8.4.1 RRC Re-establishment delay	<p>Settings: 0 dB for \hat{I}_{or} / I_{oc} 0 dB for any Ec/Ior Zero TT is applied, as level settings are not critical with respect to the outcome of the test.</p>
8.4.2 Random Access	<p>Settings: 0.3 dB for \hat{I}_{or} / I_{oc} 0.1 dB for AICH_Ec/Ior Measurements: Power difference: ± 1dB Maximum Power: -1dB / +0.7dB</p> <p>PRACH timing error 0.5 chips</p>
8.4.3 Transport format combination selection in UE	0 dB for DPCH_Ec/Ior

Clause	Test Tolerance
8.4.4 E-TFC restriction in UE	
8.4.4.1 10ms TTI E-DCH E-TFC restriction	0.1 dB for E_c/I_{or} 0.7 dB for \hat{I}_{or}
8.4.4.2 2ms TTI E-DCH E-TFC restriction	0.1 dB for E_c/I_{or} 0.7 dB for \hat{I}_{or}
8.5 Timing and Signalling Characteristics	
8.5.1 UE Transmit Timing	0.1 dB for CPICH_ E_c/I_{or} 0.1 dB for DPCH_ E_c/I_{or} 1 dB for \hat{I}_{or1} 1.3 dB for \hat{I}_{or2} 0.5 chips for Rx-Tx timing accuracy 0.25 chips for Tx-Tx Timing Accuracy
8.6 UE Measurements Procedures	
8.6.1 FDD intra frequency measurements	
8.6.1.1 Event triggered reporting in AWGN propagation conditions (R99)	During T1/T4 and T2/T3: +0.70 dB for all Cell 1 E_c/I_{or} ratios During T1/T4 only: Already covered above During T2/T3 only: +0.70 dB for all Cell 2 E_c/I_{or} ratios
8.6.1.1A Event triggered reporting in AWGN propagation conditions (Rel-4 and later)	During T1/T3 and T2: +0.70 dB for all Cell 1 E_c/I_{or} ratios During T1/T3 only: Already covered above During T2 only: +0.70 dB for all Cell 2 E_c/I_{or} ratios
8.6.1.2 Event triggered reporting of multiple neighbours in AWGN propagation condition (R99)	During T0 to T6: +0.70 dB for all Cell 1 E_c/I_{or} ratios +0.70 dB for all Cell 2 E_c/I_{or} ratios +0.70 dB for all Cell 3 E_c/I_{or} ratios
8.6.1.2A Event triggered reporting of multiple neighbours in AWGN propagation condition (Rel-4 and later)	During T0 to T4: +0.70 dB for all Cell 1 E_c/I_{or} ratios +0.70 dB for all Cell 2 E_c/I_{or} ratios +0.70 dB for all Cell 3 E_c/I_{or} ratios
8.6.1.3 Event triggered reporting of two detectable neighbours in AWGN propagation condition (R99)	During T0 to T5: +0.40 dB for all Cell 1 E_c/I_{or} ratios +0.40 dB for all Cell 2 E_c/I_{or} ratios +0.40 dB for all Cell 3 E_c/I_{or} ratios
8.6.1.3A Event triggered reporting of two detectable neighbours in AWGN propagation condition (Rel-4 and later)	During T0 to T4: +0.40 dB for all Cell 1 E_c/I_{or} ratios +0.40 dB for all Cell 2 E_c/I_{or} ratios +0.40 dB for all Cell 3 E_c/I_{or} ratios
8.6.1.4A Correct reporting of neighbours in fading propagation condition (Rel-4 and later)	During T1: +0.70 dB for all Cell 1 E_c/I_{or} ratios +0.30 dB for all Cell 2 E_c/I_{or} ratios During T2: +0.30 dB for all Cell 1 E_c/I_{or} ratios +0.70 dB for all Cell 2 E_c/I_{or} ratios
8.6.1.5 Event triggered reporting of multiple neighbour cells in Case 1 fading condition	During T1 and T2: +0.70 dB for all Cell 1 E_c/I_{or} ratios +0.70 dB for all Cell 2 E_c/I_{or} ratios +0.70 dB for all Cell 3 E_c/I_{or} ratios
8.6.1.6 Event triggered reporting of multiple neighbour cells in Case 3 fading condition	During T1 and T2: +0.70 dB for all Cell 1 E_c/I_{or} ratios +0.70 dB for all Cell 2 E_c/I_{or} ratios +0.70 dB for all Cell 3 E_c/I_{or} ratios
8.6.2 FDD inter frequency measurements	
8.6.2.1 Correct reporting of neighbours in AWGN propagation condition (Release 5 and earlier)	During T0 to T2: +0.80 dB for all Cell 1 E_c/I_{or} ratios +0.80 dB for all Cell 2 E_c/I_{or} ratios +0.80 dB for all Cell 3 E_c/I_{or} ratios

Clause	Test Tolerance
8.6.2.1A Correct reporting of neighbours in AWGN propagation condition (Release 6 and later)	During T0 to T2: +0.80 dB for all Cell 1 Ec/Ior ratios +0.80 dB for all Cell 2 Ec/Ior ratios +0.80 dB for all Cell 3 Ec/Ior ratios
8.6.2.2 Correct reporting of neighbours in Fading propagation condition (Release 5 only)	<u>During T1 and T2:</u> +0.80 dB for all Cell 1 Ec/Ior ratios +0.80 dB for all Cell 2 Ec/Ior ratios
8.6.2.2A Correct reporting of neighbours in Fading propagation condition (Release 6 and later)	<u>During T1 and T2:</u> +0.80 dB for all Cell 1 Ec/Ior ratios +0.80 dB for all Cell 2 Ec/Ior ratios
8.6.2.3 Correct reporting of neighbours in Fading propagation condition using TGL1=14	<u>During T1 and T2:</u> +0.80 dB for all Cell 1 Ec/Ior ratios +0.80 dB for all Cell 2 Ec/Ior ratios
8.6.3 TDD measurements	
8.6.3.1 Correct reporting of TDD neighbours in AWGN propagation condition	TBD
8.6.4 GSM measurements	
8.6.4.1 Correct reporting of GSM neighbours in AWGN propagation condition	<u>During T2:</u> + 1 dB for RXLEV <u>During T3:</u> -1 dB for RXLEV
8.6.5 Combined Inter frequency and GSM measurements	
8.6.5.1 Correct reporting of neighbours in AWGN propagation condition	<u>During T0 to T5:</u> +0.80 dB for all Cell 1 Ec/Ior ratios +0.80 dB for all Cell 2 Ec/Ior ratios <u>During T4 to T5:</u> + 1 dB for RXLEV
8.7 Measurements Performance Requirements	
8.7.1 CPICH RSCP	
8.7.1.1 Intra frequency measurements accuracy	0.3 dB for \hat{I}_{or}/I_{oc} 0.1 dB for CPICH_Ec/Ior 1.0 dB for loc
8.7.1.2 Inter frequency measurement accuracy	0.3 dB for \hat{I}_{or}/I_{oc} 0.1 dB for CPICH_Ec/Ior 0.3 dB for loc1/loc2 1.0 dB for loc
8.7.2 CPICH Ec/Io	
8.7.2.1 Intra frequency measurements accuracy	0.3 dB for \hat{I}_{or}/I_{oc} 0.1 dB for CPICH_Ec/Ior
8.7.2.2 Inter frequency measurement accuracy	0.3 dB for \hat{I}_{or}/I_{oc} 0.1 dB for CPICH_Ec/Ior
8.7.3.1 UTRA Carrier RSSI, absolute measurement accuracy	0.3 dB for \hat{I}_{or}/I_{oc} 1.0 dB for loc
8.7.3.2 UTRA Carrier RSSI, relative measurement accuracy	0.3 dB for \hat{I}_{or}/I_{oc} 1.0 dB for loc

Clause	Test Tolerance
8.7.3A GSM Carrier RSSI	TT for test parameters GSM cell levels: Step 1: -1 dB Step 2: -1 dB Step 3: -1 dB Step 4:+1 dB Relative accuracy requirements: a, b, c and d values in minimum requirements are increased by 2 dB i.e., For $x_1 \geq s+14$, $x_2 < -48$ dBm: a=4, b=4, c=6, d=6 For $s+14 > x_1 \geq s+1$ a=5, b=4, c=7, d=6 For $s+1 > x_1$ a=6, b=4, c=8, d=6 Absolute accuracy requirements: original minimum requirements are increased by ± 1 dB
8.7.3B Transport channel BLER	TBD
8.7.3C UE Transmitted power (R99 and Rel-4 only)	0.7 dB for mean power measurement by test system
8.7.3D UE Transmitted power (Rel-5 and later)	0.7 dB for mean power measurement by test system
8.7.4 SFN-CFN observed time difference	0.3 dB for \hat{I}_{or}/I_{oc} 1.0 dB for loc ± 0.5 chips for the actual SFN-CFN observed time difference
8.7.5.1 SFN-SFN observed time difference type 1	0.3 dB for \hat{I}_{or}/I_{oc} 1.0 dB for loc ± 0.5 chips for the actual SFN-SFN observed time difference type 1
8.7.6 UE Rx-Tx time difference	0.3 dB for \hat{I}_{or}/I_{oc} 1.0 dB for loc 0.5 chip for Rx-Tx Timing Accuracy
8.7.7 Observed time difference to GSM cell	TBD
8.7.8 P-CCPCH RSCP	TBD
8.7.9 UE Transmission Power Headroom	0.8 dB for UPH reporting accuracy

F.2.5 Performance requirements (HSDPA)

Table F.2.5: Test Tolerances for Performance Requirements (HSDPA).

Clause	Test Tolerance
9.2.1A to 9.2.1G Single Link Performance	0.6 dB for \hat{I}_{or}/I_{oc} 0.1 dB for Ec/lor
9.2.2A to 9.2.2D Open loop diversity performance	0.8 dB for \hat{I}_{or}/I_{oc} 0.1 dB for Ec/lor
9.2.3A to 9.2.3D Closed loop diversity performance	Same as 9.2.2A
9.3.1 Single Link Performance - AWGN propagation conditions	No test tolerances applied
9.3.2 Single Link Performance - Fading propagation conditions	No test tolerances applied
9.3.3 Open Loop Diversity Performance - AWGN propagation conditions	No test tolerances applied
9.3.4 Open Loop Diversity Performance - Fading propagation conditions	No test tolerances applied
9.3.5 Closed Loop Diversity Performance - AWGN propagation conditions	No test tolerances applied
9.3.6 Closed Loop Diversity Performance - Fading propagation conditions	No test tolerances applied
9.4.1 Single Link Performance	0.6 dB for \hat{I}_{or}/I_{oc} 0.1 dB for P-CPICH_Ec/lor and HS-SCCH_Ec/lor
9.4.1A Single Link Performance - Enhanced Performance Requirements Type 1	Same as 9.4.1
9.4.2 Open loop diversity performance	0.8 dB for \hat{I}_{or}/I_{oc} 0.1 dB for P-CPICH_Ec/lor and HS-SCCH_Ec/lor
9.4.2A Open loop diversity performance – Enhanced Performance Requirements Type 1	Same as 9.4.2

F.2.6 Performance requirements (E-DCH)

Table F.2.6: Test Tolerances for Performance Requirements (E-DCH)

Clause	Test Tolerance
10.2.1.1 Detection of E-DCH HARQ ACK Indicator Channel (E-HICH) Single Link Performance (10 ms)	0.6 dB for \hat{I}_{or}/I_{oc} 0.1 dB for E-HICH_Ec/lor
10.2.1.1A Detection of E-DCH HARQ ACK Indicator Channel (E-HICH) Single Link Performance (10 ms, Type 1)	0.6 dB for \hat{I}_{or}/I_{oc} 0.1 dB for E-HICH_Ec/lor
10.2.1.2 Detection of E-DCH HARQ ACK Indicator Channel (E-HICH) Single Link Performance (2 ms TTI)	0.6 dB for \hat{I}_{or}/I_{oc} 0.1 dB for E-HICH_Ec/lor
10.2.1.2A Detection of E-DCH HARQ ACK Indicator Channel (E-HICH) Single Link Performance (2 ms TTI, Type 1)	0.6 dB for \hat{I}_{or}/I_{oc} 0.1 dB for E-HICH_Ec/lor
10.2.2.1.1 Detection of E-DCH HARQ ACK Indicator Channel (E-HICH) in Inter-Cell handover conditions – RLS not containing the serving E-DCH cell (10 ms TTI)	0.6 dB for \hat{I}_{or1}/I_{oc} and \hat{I}_{or2}/I_{oc} 0.1 dB for E-HICH_Ec/lor
10.2.2.1.1A Detection of E-DCH HARQ ACK Indicator Channel (E-HICH) in Inter-Cell handover conditions – RLS not containing the serving E-DCH cell (10 ms TTI, Type 1)	0.6 dB for \hat{I}_{or1}/I_{oc} and \hat{I}_{or2}/I_{oc} 0.1 dB for E-HICH_Ec/lor
10.2.2.1.2 Detection of E-DCH HARQ ACK Indicator Channel (E-HICH) in Inter-Cell handover conditions – RLS not containing the serving E-DCH cell (2 ms TTI)	0.6 dB for \hat{I}_{or1}/I_{oc} and \hat{I}_{or2}/I_{oc} 0.1 dB for E-HICH_Ec/lor
10.2.2.1.2A Detection of E-DCH HARQ ACK Indicator Channel (E-HICH) in Inter-Cell handover conditions – RLS not containing the serving E-DCH cell (2 ms TTI, Type 1)	0.6 dB for \hat{I}_{or1}/I_{oc} and \hat{I}_{or2}/I_{oc} 0.1 dB for E-HICH_Ec/lor
10.2.2.2.1 Detection of E-DCH HARQ ACK Indicator Channel (E-HICH) in Inter-Cell handover conditions – RLS containing the serving E-DCH cell (10 ms TTI)	0.6 dB for \hat{I}_{or1}/I_{oc} and \hat{I}_{or2}/I_{oc} 0.1 dB for E-HICH_Ec/lor
10.2.2.2.1A Detection of E-DCH HARQ ACK Indicator Channel (E-HICH) in Inter-Cell handover conditions – RLS containing the serving E-DCH cell (10 ms TTI, Type 1)	0.6 dB for \hat{I}_{or1}/I_{oc} and \hat{I}_{or2}/I_{oc} 0.1 dB for E-HICH_Ec/lor
10.2.2.2.2 Detection of E-DCH HARQ ACK Indicator Channel (E-HICH) in Inter-Cell handover conditions – RLS containing the serving E-DCH cell (2 ms TTI)	0.6 dB for \hat{I}_{or1}/I_{oc} and \hat{I}_{or2}/I_{oc} 0.1 dB for E-HICH_Ec/lor
10.2.2.2.2A Detection of E-DCH HARQ ACK Indicator Channel (E-HICH) in Inter-Cell handover conditions – RLS containing the serving E-DCH cell (2 ms TTI, Type 1)	0.6 dB for \hat{I}_{or1}/I_{oc} and \hat{I}_{or2}/I_{oc} 0.1 dB for E-HICH_Ec/lor
10.3.1.1 Detection of E-DCH Relative Grant Channel (E-RGCH) Single Link Performance (10 ms TTI)	0.6 dB for \hat{I}_{or}/I_{oc} 0.1 dB for E-RGCH_Ec/lor
10.3.1.1A Detection of E-DCH Relative Grant Channel (E-RGCH) Single Link Performance (10 ms TTI, Type 1)	0.6 dB for \hat{I}_{or}/I_{oc} 0.1 dB for E-RGCH_Ec/lor
10.3.1.2 Detection of E-DCH Relative Grant Channel (E-RGCH) Single Link Performance (2 ms TTI)	0.6 dB for \hat{I}_{or}/I_{oc} 0.1 dB for E-RGCH_Ec/lor
10.3.1.2A Detection of E-DCH Relative Grant Channel (E-RGCH) Single Link Performance (2 ms TTI, Type 1)	0.6 dB for \hat{I}_{or}/I_{oc} 0.1 dB for E-RGCH_Ec/lor
10.3.2 Detection of E-DCH Relative Grant Channel (E-RGCH) in Inter-Cell Handover conditions	0.6 dB for \hat{I}_{or1}/I_{oc} and \hat{I}_{or2}/I_{oc} 0.1 dB for E-RGCH_Ec/lor
10.3.2A Detection of E-DCH Relative Grant Channel (E-RGCH) in Inter-Cell Handover conditions (Type 1)	0.6 dB for \hat{I}_{or1}/I_{oc} and \hat{I}_{or2}/I_{oc} 0.1 dB for E-RGCH_Ec/lor
10.4.1 Demodulation of E-DCH Absolute Grant Channel (E-AGCH) Single Link Performance	0.6 dB for \hat{I}_{or}/I_{oc} 0.1 dB for E-AGCH_Ec/lor
10.4.1A Demodulation of E-DCH Absolute Grant Channel (E-AGCH) Single Link Performance (Type 1)	0.6 dB for \hat{I}_{or}/I_{oc} 0.1 dB for E-AGCH_Ec/lor

F.2.7 Performance requirements (MBMS)

Table F.2.7: Test Tolerances for Performance Requirements (MBMS).

Clause	Test Tolerance
11.3 Demodulation of MTCH and cell identification	0.1 dB for S-CCPCH_Ec/I _{or} 0.6 dB for \hat{I}_{or1}/I_{oc} , \hat{I}_{or2}/I_{oc} and \hat{I}_{or3}/I_{oc} .

F.3 Interpretation of measurement results

The measurement results returned by the Test System are compared – without any modification – against the Test Requirements as defined by the shared risk principle.

The Shared Risk principle is defined in ETR 273-1-2 clause 6.5.

The actual measurement uncertainty of the Test System for the measurement of each parameter shall be included in the test report.

The recorded value for the Test System uncertainty shall be, for each measurement, equal to or lower than the appropriate figure in clause F.1 of the present document.

If the Test System for a test is known to have a measurement uncertainty greater than that specified in clause F.1, it is still permitted to use this apparatus provided that an adjustment is made value as follows.

Any additional uncertainty in the Test System over and above that specified in clause F.1 shall be used to tighten the Test Requirement – making the test harder to pass. (For some tests e.g. receiver tests, this may require modification of stimulus signals). This procedure will ensure that a Test System not compliant with clause F.1 does not increase the chance of passing a device under test where that device would otherwise have failed the test if a Test System compliant with clause F.1 had been used.

For some of the more complex tests e.g. RRM, deriving the overall test system uncertainty is not straightforward. In such cases the derivation is given in TR 34.902 [24] rather than in subclause F.1. If it is deemed necessary to apply the additional test system uncertainty rules to these tests, the formula for deriving the new overall uncertainty from any excess fundamental test system uncertainties, shall use the formulas provided in 34.902.

F.4 Derivation of Test Requirements (This clause is informative)

The Test Requirements in the present document have been calculated by relaxing the Minimum Requirements of the core specification using the Test Tolerances defined in clause F.2. When the Test Tolerance is zero, the Test Requirement will be the same as the Minimum Requirement. When the Test Tolerance is non-zero, the Test Requirements will differ from the Minimum Requirements, and the formula used for this relaxation is given in table F.4.

F.4.1 Transmitter

Table F.4.1: Derivation of Test Requirements (Transmitter tests)

Test	Minimum Requirement in TS 25.101	Test Tolerance (TT)	Test Requirement in TS 34.121
5.2 Maximum Output Power	Power class 1 (33 dBm) Tolerance = +1/-3 dB Power class 2 (27 dBm) Tolerance = +1/-3 dB Power class 3 (24 dBm) Tolerance = +1/-3 dB Power class 4 (21 dBm) Tolerance = ±2 dB	0.7 dB	Formula: (Upper) Minimum Requirement + TT (Lower) Minimum Requirement – TT For power classes 1-3: Upper Tolerance limit = +1.7 dB Lower Tolerance limit = -3.7 dB For power class 4: Upper Tolerance limit = +2.7 dB Lower Tolerance limit = -2.7 dB
5.2A Maximum Output Power with HS-DPCCH (Release 5 only)	For Power class 3: Power class 3 (24 dBm) Tolerance = +1/-3 dB Power class 3 (23 dBm) Tolerance = +2/-3 dB Power class 3 (22 dBm) Tolerance = +3/-3 dB For Power class 4: Power class 4 (21 dBm) Tolerance = ±2 dB Power class 4 (20 dBm) Tolerance = +3/-2 dB Power class 4 (19 dBm) Tolerance = +4/-2 dB	0.7 dB	Formula: (Upper) Minimum Requirement + TT (Lower) Minimum Requirement – TT For power classes 3: Upper Tolerance limit = +1.7 dB (24 dBm) Upper Tolerance limit = +2.7 dB (23 dBm) Upper Tolerance limit = +1.7 dB (22 dBm) Lower Tolerance limit = -3.7 dB For power class 4: Upper Tolerance limit = +2.7 dB (24 dBm) Upper Tolerance limit = +3.7 dB (23 dBm) Upper Tolerance limit = +4.7 dB (22 dBm) Lower Tolerance limit = -2.7 dB

Test	Minimum Requirement in TS 25.101	Test Tolerance (TT)	Test Requirement in TS 34.121
5.2AA Maximum Output Power with HS-DPCCH (Release 6 and later)	For Power class 3: Sub-test 1: Power class 3 (24 dBm) Tolerance = +1/-3 dB Sub-test 2: Power class 3 (24 dBm) Tolerance = +1/-3 dB Sub-test 3: Power class 3 (23.5 dBm) Tolerance = +1.5/-3 dB Sub-test 4: Power class 3 (23.5 dBm) Tolerance = +1.5/-3 dB For Power class 4: Sub-test 1: Power class 4 (21 dBm) Tolerance = ±2 dB Sub-test 2: Power class 4 (21 dBm) Tolerance = ±2 dB Sub-test 3: Power class 4 (20.5 dBm) Tolerance = +2.5/-2 dB Sub-test 4: Power class 4 (20.5 dBm) Tolerance = +2.5/-2 dB	0.7 dB	Formula: (Upper) Minimum Requirement + TT (Lower) Minimum Requirement – TT For power classes 3: Sub-test 1: Upper Tolerance limit = +1.7 dB (24 dBm) Sub-test 1: Lower Tolerance limit = -3.7 dB Sub-test 2: Upper Tolerance limit = +1.7 dB (24 dBm) Sub-test 2: Lower Tolerance limit = -3.7 dB Sub-test 3: Upper Tolerance limit = +2.2 dB (23.5 dBm) Sub-test 3: Lower Tolerance limit = -3.7 dB Sub-test 4: Upper Tolerance limit = +2.2 dB (23.5 dBm) Sub-test 4: Lower Tolerance limit = -3.7 dB For power class 4: Sub-test 1: Upper Tolerance limit = +2.7 dB (21 dBm) Sub-test 1: Lower Tolerance limit = -2.7 dB Sub-test 2: Upper Tolerance limit = +2.7 dB (21 dBm) Sub-test 2: Lower Tolerance limit = -2.7 dB Sub-test 3: Upper Tolerance limit = +3.2 dB (20.5 dBm) Sub-test 3: Lower Tolerance limit = -2.7 dB Sub-test 4: Upper Tolerance limit = +3.2 dB (20.5 dBm) Sub-test 4: Lower Tolerance limit = -2.7 dB

Test	Minimum Requirement in TS 25.101	Test Tolerance (TT)	Test Requirement in TS 34.121
5.2B Maximum Output Power with HS-DPCCH and E-DCH	<p>For Power class 3:</p> <p>Sub-test 1: Power class 3 (24 dBm) Tolerance = +1/-3</p> <p>Sub-test 2: Power class 3 (22 dBm) Tolerance = +3/-3</p> <p>Sub-test 3: Power class 3 (23 dBm) Tolerance = +2/-3</p> <p>Sub-test 4: Power class 3 (22 dBm) Tolerance = +1/-3</p> <p>Sub-test 5: Power class 3 (24 dBm) Tolerance = +1/-3</p> <p>For Power class 4:</p> <p>Sub-test 1: Power class 4 (21 dBm) Tolerance = ±2 dB</p> <p>Sub-test 2: Power class 4 (19 dBm) Tolerance = +4/-2 dB</p> <p>Sub-test 3: Power class 4 (20 dBm) Tolerance = +3/-2 dB</p> <p>Sub-test 4: Power class 4 (19 dBm) Tolerance = +4/-2 dB</p> <p>Sub-test 5: Power class 4 (21 dBm) Tolerance = ±2 dB</p>	0.7 dB	<p>Formula: (Upper) Minimum Requirement + TT (Lower) Minimum Requirement – TT</p> <p>For power classes 3:</p> <p>Sub-test 1: Upper Tolerance limit = +1.7 dB (24 dBm) Sub-test 1: Lower Tolerance limit = -3.7 dB (24 dBm)</p> <p>Sub-test 2: Upper Tolerance limit = +3.7 dB (22 dBm) Sub-test 2: Lower Tolerance limit = -3.7 dB (22 dBm)</p> <p>Sub-test 3: Upper Tolerance limit = +2.7 dB (23 dBm) Sub-test 3: Lower Tolerance limit = -3.7 dB (23 dBm)</p> <p>Sub-test 4: Upper Tolerance limit = +3.7 dB (22 dBm) Sub-test 4: Lower Tolerance limit = -3.7 dB (22 dBm)</p> <p>Sub-test 5: Upper Tolerance limit = +1.7 dB (24 dBm) Sub-test 5: Lower Tolerance limit = -3.7 dB (24 dBm)</p> <p>For power class 4:</p> <p>Sub-test 1: Upper Tolerance limit = +2.7 dB (21 dBm) Sub-test 1: Lower Tolerance limit = -2.7 dB (21 dBm)</p> <p>Sub-test 2: Upper Tolerance limit = +4.7 dB (19 dBm) Sub-test 2: Lower Tolerance limit = -2.7 dB (19 dBm)</p> <p>Sub-test 3: Upper Tolerance limit = +3.7 dB (20 dBm) Sub-test 3: Lower Tolerance limit = -2.7 dB (20 dBm)</p> <p>Sub-test 4: Upper Tolerance limit = +4.7 dB (19 dBm) Sub-test 4: Lower Tolerance limit = -2.7 dB (19 dBm)</p> <p>Sub-test 5: Upper Tolerance limit = +2.7 dB (21 dBm) Sub-test 5: Lower Tolerance limit = -2.7 dB (21 dBm)</p>
5.2C UE relative code domain power accuracy	<p>For 0 dB ≥ -10 dB CDP ± 1.5 dB</p> <p>For -10 dB ≥ -15 dB CDP ± 2.0 dB</p> <p>For -15 dB ≥ -20 dB CDP ± 2.5 dB</p>	<p>For 0 dB ≥ -10 dB CDP 0.2 dB</p> <p>For -10 dB ≥ -15 dB CDP 0.3 dB</p> <p>For -15 dB ≥ -20 dB CDP 0.4 dB</p>	<p>Formula: UE relative CDP accuracy + TT</p> <p>For 0 dB ≥ -10 dB CDP ± 1.7 dB</p> <p>For -10 dB ≥ -15 dB CDP ± 2.3 dB</p> <p>For -15 dB ≥ -20 dB CDP ± 2.9 dB</p>
5.2D UE Relative Code Domain Power Accuracy with HS-DPCCH and E-DCH	<p>For 0 dB ≥ -10 dB CDP ±1.5 dB</p> <p>For -10 dB ≥ -15 dB CDP ± 2.0 dB</p> <p>For -15 dB ≥ -20 dB CDP ± 2.5 dB</p>	<p>For 0 dB ≥ -10 dB CDP 0.2 dB</p> <p>For -10 dB ≥ -15 dB CDP 0.3 dB</p> <p>For -15 dB ≥ -20 dB CDP 0.4 dB</p>	<p>Formula: UE relative CDP accuracy + TT</p> <p>For 0 dB ≥ -10 dB CDP ± 1.7 dB</p> <p>For -10 dB ≥ -15 dB CDP ± 2.3 dB</p> <p>For -15 dB ≥ -20 dB CDP ± 2.9 dB</p>

Test	Minimum Requirement in TS 25.101	Test Tolerance (TT)	Test Requirement in TS 34.121
5.3 Frequency Error	The UE modulated carrier frequency shall be accurate to within ± 0.1 ppm compared to the carrier frequency received from the Node B.	10 Hz	Formula: modulated carrier frequency error + TT modulated carrier frequency error = $\pm(0.1 \text{ ppm} + 10 \text{ Hz})$.
5.4.1 Open loop power control in the uplink	Open loop power control tolerance ± 9 dB (Normal) Open loop power control tolerance ± 12 dB (Extreme)	1.0 dB	Formula: (Upper) Minimum Requirement + TT (Lower) Minimum Requirement - TT For Normal conditions: Upper Tolerance limit = +10 dB Lower Tolerance limit = -10 dB For Extreme conditions: Upper Tolerance limit = +13 dB Lower Tolerance limit = -13 dB
5.4.2 Inner loop power control in uplink	See table 5.4.2.1 and 5.4.2.2	0.1dB 0.15 dB 0.2 dB 0.3 dB	Formula: (Upper) Minimum Requirement + TT (Lower) Minimum Requirement - TT
5.4.3 Minimum Output Power	UE minimum transmit power shall be less than -50 dBm	1.0 dB	Formula: Minimum Requirement + TT UE minimum transmit power = -49 dBm
5.4.4 Out-of-synchronisation handling of output power:	$\frac{DPCCCH_E_c}{I_{or}}$ levels AB: -22 dB BD: -28 dB DE: -24 dB EF: -18 dB transmit ON/OFF time 200ms $\frac{DPDCH_E_c}{I_{or}} = -16.6 \text{ dB}$ $I_{oc} - 60 \text{ dBm}$ $\hat{I}_{or}/I_{oc} = -1 \text{ dB}$	0.4 dB for $\frac{DPCCCH_E_c}{I_{or}}$ 0 ms for timing measurement	Formulas: Minimum Requirement between A and B + TT Minimum Requirement between B and D - TT Minimum Requirement between D and E - TT Minimum Requirement between E and F + TT transmit ON/OFF time Minimum Requirement + TT timing $\frac{DPDCH_E_c}{I_{or}} = -16.6 \text{ dB}$ $I_{oc} - 60 \text{ dBm}$ $\hat{I}_{or}/I_{oc} = -1 \text{ dB}$ $\frac{DPCCCH_E_c}{I_{or}}$ levels: AB: -21.6 dB BD: -28.4 dB DE: -24.4 dB EF: -17.6 dB transmit ON/OFF time 200ms timing Uncertainty of OFF power measurement is handled by Transmit OFF power test and uncertainty of ON power measurement is handled by Minimum output power test.

Test	Minimum Requirement in TS 25.101	Test Tolerance (TT)	Test Requirement in TS 34.121
5.5.1 Transmit OFF power (static case)	Transmit OFF power shall be less than -56 dBm	1.0 dB	Formula: Transmit OFF power Minimum Requirement + TT Transmit OFF power = -55dBm.
5.5.2 Transmit ON/OFF time mask (dynamic case)	Transmit ON power shall be the target value as defined in clause 5.5.2.2 Transmit OFF power shall be less than -56 dBm	On power upper TT = 0.7 dB On power lower TT = 1.0 dB Off power TT = 1.0 dB	Formula for transmit ON power: (Upper) Minimum Requirement (Transmit ON power) + On power upper TT (Lower) Minimum Requirement (Transmit ON power) - On power lower TT To calculate Transmit ON power target value range take the nominal TX power range from Table 5.5.2.3 then apply table 5.4.1.1 open limits then apply table 5.7.1 (only if there has been a transmission gap) then cap the upper value using table 5.2.1. Formula for transmit OFF power: Transmit OFF power Minimum Requirement + Off power TT Transmit OFF power = -55 dBm
5.6 Change of TFC: power control step size	TFC step size = 7dB (Up or Down) Tolerance=±2dB	0.3 dB	For the nominal -7dB step: (Upper) Minimum Requirement + TT = -4.7 dB (Lower) Minimum Requirement - TT = -9.3 dB For the nominal +7dB step: (Upper) Minimum Requirement + TT = +9.3 dB (Lower) Minimum Requirement - TT = +4.7 dB
5.7 Power setting in uplink compressed mode	See tables 5.7.2 and 5.7.3	Subset of 5.4.2	Formula: (Upper) Minimum Requirement + TT (Lower) Minimum Requirement - TT
5.7A HS-DPCCH	See table 5.7A.1 and 5.7A.2	0.1 dB 0.15 dB 0.2 dB 0.3 dB	Formula: (Upper) Minimum Requirement + TT (Lower) Minimum Requirement - TT
5.8 Occupied Bandwidth	The occupied channel bandwidth shall be less than 5 MHz based on a chip rate of 3.84 Mcps.	0 kHz	Formula: occupied channel bandwidth Minimum Requirement + TT occupied channel bandwidth = 5.0 MHz
5.9 Spectrum emission mask	Minimum requirement defined in TS25.101 Table 6.10. The lower limit shall be -50 dBm / 3.84 MHz or which ever is higher. This is expressed as the equivalent power in the measurement band-width used at each offset.	1.5 dB	Formula: Minimum requirement + TT Lower limit Minimum Requirement + TT Add 1.5 to Minimum requirement entries in TS25.101 Table 6.10. Zero test tolerance is applied for Additional requirements for Band II, Band IV Band V and Band X due to FCC regulatory requirements. The lower limit shall be -48.5 dBm / 3.84 MHz or which ever is higher.

Test	Minimum Requirement in TS 25.101		Test Tolerance (TT)	Test Requirement in TS 34.121	
5.9A Spectrum emission mask with HS-DPCCH	Minimum requirement defined in TS25.101 Table 6.10. The lower limit shall be -50 dBm / 3.84 MHz or which ever is higher.		1.5 dB	Formula: Minimum requirement + TT Lower limit Minimum Requirement + TT Add 1.5 to Minimum requirement entries in TS25.101 Table 6.10. Zero test tolerance is applied for Additional requirements for Band II, Band IV, Band V and Band X due to FCC regulatory requirements. The lower limit shall be -48.5 dBm / 3.84 MHz or which ever is higher.	
5.9B Spectrum emission mask with E-DCH	Minimum requirement defined in TS25.101 Table 6.10. The lower limit shall be -50 dBm / 3.84 MHz or which ever is higher.		1.5 dB	Formula: Lower limit Minimum Requirement + TT Add 1.5 to Minimum requirement entries in TS25.101 Table 6.10. Zero test tolerance is applied for Additional requirements for Band II, Band IV, Band V and Band X due to FCC regulatory requirements. The lower limit shall be -48.5 dBm / 3.84 MHz or which ever is higher.	
5.10 Adjacent Channel Leakage Power Ratio (ACLR)	If the adjacent channel power is greater than -50 dBm then the ACLR shall be higher than the values specified below.		0.0 dB	Formula: Absolute power threshold + TT	
	Power Classes 3 and 4: UE channel +5 MHz or -5 MHz, ACLR limit: 33 dB UE channel +10 MHz or -10 MHz, ACLR limit: 43 dB		0.8 dB	Formula: ACLR Minimum Requirement - TT Power Classes 3 and 4: UE channel +5 MHz or -5 MHz, ACLR limit = 32.2 dB UE channel +10 MHz or -10 MHz, ACLR limit = 42.2 dB	
5.10A Adjacent Channel Leakage Power Ratio (ACLR) with HS-DPCCH	If the adjacent channel power is greater than -50 dBm then the ACLR shall be higher than the values specified below.		0.0 dB	Formula: Absolute power threshold + TT	
	Power Classes 3 and 4: UE channel +5 MHz or -5MHz, ACLR limit: 33 dB UE channel +10 MHz or -10MHz, ACLR limit: 43 dB		0.8 dB	Formula: ACLR Minimum Requirement - TT Power Classes 3 and 4: UE channel +5 MHz or -5MHz, ACLR Limit : 32.2 dB UE channel +10 MHz or -10MHz, ACLR Limit: 42.2 dB	
5.10B Adjacent Channel Leakage Power Ratio (ACLR) with E-DCH	If the adjacent channel power is greater than -50 dBm then the ACLR shall be higher than the values specified below.		0.0 dB	Formula: Absolute power threshold Minimum Requirement + TT	
	Power Classes 3 and 4: UE channel +5 MHz or -5MHz, ACLR limit: 33 dB UE channel +10 MHz or -10MHz, ACLR limit: 43 dB		0.8 dB	Formula: ACLR Minimum Requirement- TT Power Classes 3 and 4: UE channel +5 MHz or -5MHz, ACLR Limit: 32.2 dB UE channel +10 MHz or -10MHz, ACLR Limit:42.2 dB	
5.11 Spurious Emissions				Formula: Minimum Requirement+ TT Add zero to all the values of Minimum Requirements in table 5.11.1a and 5.11.1b.	
	Frequency Band	Minimum Requirement		Frequency Band	Minimum Requirement
	9 kHz ≤ f < 150 kHz	-36dBm /1kHz	0 dB	9kHz ≤ f < 1GHz	-36dBm /1kHz

Test	Minimum Requirement in TS 25.101		Test Tolerance (TT)	Test Requirement in TS 34.121	
	150 kHz ≤ f < 30 MHz	-36dBm /10kHz	0 dB	150 kHz ≤ f < 30 MHz	-36dBm /10kHz
	30 MHz ≤ f < 1000 MHz	-36dBm /100kHz	0 dB	30 MHz ≤ f < 1000 MHz	-36dBm /100kHz
	1 GHz ≤ f < 12.75 GHz		0 dB	1 GHz ≤ f < 2.2 GHz	-30dBm /1MHz
			0 dB	2.2 GHz ≤ f < 4 GHz	-30dBm /1MHz
			0 dB	4 GHz ≤ f < 12.75 GHz	-30dBm /1MHz
	1893.5 MHz < f < 1919.6 MHz	-41dBm /300kHz	0 dB	1893.5 MHz < f < 1919.6 MHz	-41dBm /300kHz
	925 MHz ≤ f ≤ 935 MHz	-67dBm /100kHz	0 dB	925 MHz ≤ f ≤ 935 MHz	-67dBm /100kHz
	935 MHz < f ≤ 960 MHz	-79dBm /100kHz	0 dB	935 MHz < f ≤ 960 MHz	-79dBm /100kHz
1805 MHz ≤ f ≤ 1880 MHz	-71dBm /100kHz	0 dB	1805 MHz ≤ f ≤ 1880 MHz	-71dBm /100kHz	
5.12 Transmit Intermodulation	Intermodulation Product 5MHz -31 dBc 10MHz -41 dBc CW Interferer level = -40 dBc		0 dB	Formula: CW interferer Minimum Requirement- TT/2 Intermod Products limits remain unchanged. CW interferer level = -40 dBc	
5.13.1 Transmit modulation: EVM	The measured EVM shall not exceed 17.5%.		0%	Formula: EVM Minimum Requirement + TT EVM limit = 17.5 %	
5.13.1A Transmit modulation: EVM with HS-DPCCH	The measured EVM shall not exceed 17.5%.		0%	Formula: EVM Minimum Requirement + TT EVM limit = 17.5 %	
5.13.1AA Transmit modulation: EVM with HS-DPCCH	The measured EVM shall not exceed 17.5%.		0%	Formula: EVM Minimum Requirement + TT EVM limit = 17.5 %	
	Phase discontinuity:		[6] degree	Formula: Phase discontinuity + TT	
5.13.2 Transmit modulation: peak code domain error	The measured Peak code domain error shall not exceed -15 dB.		1.0 dB	Formula: Peak code domain Minimum Requirement + TT Peak code domain error = -14 dB	
5.13.2A Relative Code Domain Error	The measured RCDE shall not exceed table 5.13.2A.1		0.5 dB	Formula: UE RCDE requirement +TT	
5.13.2B Relative Code Domain Error with HS-DPCCH and E-DCH	The measured RCDE shall not exceed table 5.13.2B.1.		0.5 dB	Formula: UE RCDE requirement + TT	
5.13.3 UE phase discontinuity	EVM:The measured EVM shall not exceed 17.5%.		0%	Formula: EVM Minimum Requirement + TT EVM limit = 17.5 %	
	Frequency error: The UE modulated carrier frequency shall be accurate to within +/-0.1 ppm compared to the carrier frequency received from the Node B.		10 Hz	Formula: modulated carrier frequency error + TT modulated carrier frequency error = +/- (0.1 ppm + 10 Hz).	
	Phase discontinuity:		6 degree	Formula: Phase discontinuity + TT	
5.13.4 PRACH preamble quality (EVM)	The measured EVM shall not exceed 17.5%.		0%	Formula: EVM Minimum Requirement + TT EVM limit = 17.5 %	
5.13.4 PRACH preamble quality (Frequency error)	The UE modulated carrier frequency shall be accurate to within +/-0.1 ppm compared to the carrier frequency received from the Node B.		10 Hz	Formula: modulated carrier frequency error Minimum Requirement + TT modulated carrier frequency error = +/- (0.1 ppm + 10 Hz).	

F.4.2 Receiver

Table F.4.2: Derivation of Test Requirements (Receiver tests)

Test	Minimum Requirement in TS 25.101	Test Tolerance (TT)	Test Requirement in TS 34.121
6.2 Reference sensitivity level	$\hat{I}_{or} = -106.7 \text{ dBm} / 3.84 \text{ MHz}$ DPCH_Ec = $-117 \text{ dBm} / 3.84 \text{ MHz}$ BER limit = 0.001	0.7 dB	Formula: \hat{I}_{or} Minimum Requirement + TT DPCH_Ec + TT BER limit unchanged $\hat{I}_{or} = -106 \text{ dBm} / 3.84 \text{ MHz}$ DPCH_Ec = $-116.3 \text{ dBm} / 3.84 \text{ MHz}$
6.3 Maximum input level	-25 dBm I_{or} -19 dBc DPCH_Ec/ I_{or}	0.7 dB	Formula: I_{or} Minimum Requirement -TT $I_{or} = -25.7 \text{ dBm}$
6.3A Maximum Input Level for HS-PDSCH Reception (16QAM)	-25 dBm I_{or}	0.7 dB	Formula: Minimum Requirement -TT $I_{or} = -25.7 \text{ dBm}$
6.4 Adjacent Channel Selectivity (Rel-99 and Rel-4)	$\hat{I}_{or} = -92.7 \text{ dBm} / 3.84 \text{ MHz}$ DPCH_Ec = $-103 \text{ dBm} / 3.84 \text{ MHz}$ I_{oac} (modulated) = -52 dBm/3.84 MHz BER limit = 0.001	0 dB	Formula: \hat{I}_{or} unchanged DPCH_Ec unchanged I_{oac} Minimum Requirement – TT BER limit unchanged $I_{oac} = -52 \text{ dBm}/3.84 \text{ MHz}$
6.4A Adjacent Channel Selectivity (Rel-5 and later releases)	Case 1: $\hat{I}_{or} = \langle \text{REF} \hat{I}_{or} \rangle + 14 \text{ dB} / 3.84 \text{ MHz}$ DPCH_Ec = $\langle \text{REFSENS} \rangle + 14 \text{ dB} / 3.84 \text{ MHz}$ I_{oac} (modulated) = -52 dBm/3.84 MHz BER limit = 0.001 Case 2: $\hat{I}_{or} = \langle \text{REF} \hat{I}_{or} \rangle + 41 \text{ dB} / 3.84 \text{ MHz}$ DPCH_Ec = $\langle \text{REFSENS} \rangle + 41 \text{ dB} / 3.84 \text{ MHz}$ I_{oac} (modulated) = -25 dBm/3.84 MHz BER limit = 0.001	0 dB	Formula: \hat{I}_{or} unchanged DPCH_Ec unchanged I_{oac} Minimum Requirement – TT BER limit unchanged Case1: $I_{oac} = -52 \text{ dBm}/3.84 \text{ MHz}$ Case2: $I_{oac} = -25 \text{ dBm}/3.84 \text{ MHz}$
6.5 Blocking Characteristics	See Table 6.5.3 and 6.5.4. in TS34.121 BER limit = 0.001	0 dB	Formula: $I_{\text{blocking}}(\text{modulated})$ Minimum Requirement - TT (dBm/3.84MHz) $I_{\text{blocking}}(\text{CW})$ Minimum Requirement - TT (dBm) BER limit unchanged
6.6 Spurious Response	$I_{\text{blocking}}(\text{CW}) -44 \text{ dBm}$ F _{uw} : Spurious response frequencies BER limit = 0.001	0 dB	Formula: $I_{\text{blocking}}(\text{CW})$ Minimum Requirement - TT (dBm) F _{uw} unchanged BER limit unchanged $I_{\text{blocking}}(\text{CW}) = -44 \text{ dBm}$
6.7 Intermodulation Characteristics	$I_{\text{low1}}(\text{CW}) -46 \text{ dBm}$ $I_{\text{low2}}(\text{modulated}) -46 \text{ dBm} / 3.84 \text{ MHz}$ F _{w1} (offset) 10 MHz F _{w2} (offset) 20 MHz $I_{or} = -103.7 \text{ dBm}/3.84 \text{ MHz}$ DPCH_Ec = $-114 \text{ dBm}/3.84$ BER limit = 0.001	0 dB	Formula: I_{or} Minimum Requirement + TT DPCH_Ec + TT I_{low1} level unchanged I_{low2} level unchanged BER limit unchanged. $I_{or} = -114 \text{ dBm}$ BER limit. = 0.001
6.8 Spurious Emissions			Formula: Maximum level + TT Add zero to all the values of Maximum Level in table 6.8.1.

Test	Minimum Requirement in TS 25.101		Test Tolerance (TT)	Test Requirement in TS 34.121	
	Frequency Band	Maximum level		Frequency Band	Maximum level
	9kHz ≤ f < 1GHz	-57dBm /100kHz	0 dB	9kHz ≤ f < 1GHz	-57dBm /100kHz
	1GHz ≤ f ≤ 12.75GHz	-47dBm /1MHz	0 dB	1GHz ≤ f ≤ 2.2GHz	-47dBm /1MHz
			0 dB	2.2GHz < f ≤ 4GHz	-47dBm /1MHz
			0 dB	4GHz < f ≤ 12.75GHz	-47dBm /1MHz
	1920MHz ≤ f ≤ 1980MHz	-60dBm /3.84MHz	0 dB	1920MHz ≤ f ≤ 1980MHz	-60dBm /3.84MHz
	2110MHz ≤ f ≤ 2170MHz	-60dBm /3.84MHz	0 dB	2110MHz ≤ f ≤ 2170MHz	-60dBm /3.84MHz

F.4.3 Performance requirements

Table F.4.3: Derivation of Test Requirements (Performance tests)

Test	Minimum Requirement in TS 25.101	Test Tolerance (TT)	Test Requirement in TS 34.121
7.2 Demodulation of DPCH in static conditions	$\frac{DPCH_E_c}{I_{or}} \text{ -5.5 to -16.6 dB}$ $I_{OC} = -60 \text{ dBm}$ $\hat{I}_{or}/I_{oc} = -1 \text{ dB}$	0.1 dB for $\frac{DPCH_E_c}{I_{or}}$ 0.3 dB for \hat{I}_{or}/I_{oc}	Formulas: $\frac{DPCH_E_c}{I_{or}} = \text{Minimum Requirement} + TT$ $\hat{I}_{or}/I_{oc} = \text{Minimum Requirement} + TT$ $I_{OC} \text{ unchanged}$ $\hat{I}_{or}/I_{oc} = -0.7 \text{ dB}$ $\frac{DPCH_E_c}{I_{or}} = -5.4 \text{ to } -16.5 \text{ dB:}$
7.3 Demodulation of DPCH in multi-path fading propagation conditions Tests 1-4	$\frac{DPCH_E_c}{I_{or}} \text{ -2.2 to -15.0}$ $I_{OC} = -60 \text{ dBm}$ $\hat{I}_{or}/I_{oc} = 9 \text{ dB to } -3 \text{ dB}$	0.1 dB for $\frac{DPCH_E_c}{I_{or}}$ 0.6 dB for \hat{I}_{or}/I_{oc}	Formulas: $\frac{DPCH_E_c}{I_{or}} = \text{Minimum Requirement} + TT$ $\hat{I}_{or}/I_{oc} = \text{Minimum Requirement} + TT$ $I_{OC} \text{ unchanged}$ $\hat{I}_{or}/I_{oc} = 9.6 \text{ to } -2.4 \text{ dB}$ $\frac{DPCH_E_c}{I_{or}} = -2.1 \text{ to } -14.9 \text{ dB:}$
7.3 Demodulation of DPCH in multi-path fading propagation conditions Tests 5-8	$\frac{DPCH_E_c}{I_{or}} \text{ -3.2 to -7.7 dB}$ $I_{OC} = -60 \text{ dBm}$ $\hat{I}_{or}/I_{oc} = 6 \text{ dB to } -3 \text{ dB}$	0.1 dB for $\frac{DPCH_E_c}{I_{or}}$ 0.6 dB for \hat{I}_{or}/I_{oc}	Formulas: $\frac{DPCH_E_c}{I_{or}} = \text{Minimum Requirement} + TT$ $\hat{I}_{or}/I_{oc} = \text{Minimum Requirement} + TT$ $I_{OC} \text{ unchanged}$ $\hat{I}_{or}/I_{oc} = 6.6 \text{ to } -2.4 \text{ dB}$ $\frac{DPCH_E_c}{I_{or}} = -3.1 \text{ to } -7.6 \text{ dB:}$
7.3 Demodulation of DPCH in multi-path fading propagation conditions Tests 9-12	$\frac{DPCH_E_c}{I_{or}} \text{ -4.4 to -11.8 dB}$ $I_{OC} = -60 \text{ dBm}$ $\hat{I}_{or}/I_{oc} = 6 \text{ dB to } -3 \text{ dB}$	0.1 dB for $\frac{DPCH_E_c}{I_{or}}$ 0.6 dB for \hat{I}_{or}/I_{oc}	Formulas: $\frac{DPCH_E_c}{I_{or}} = \text{Minimum Requirement} + TT$ $\hat{I}_{or}/I_{oc} = \text{Minimum Requirement} + TT$ $I_{OC} \text{ unchanged}$ $\hat{I}_{or}/I_{oc} = 6.6 \text{ to } -2.4 \text{ dB}$ $\frac{DPCH_E_c}{I_{or}} = -4.3 \text{ to } -11.7 \text{ dB:}$

Test	Minimum Requirement in TS 25.101	Test Tolerance (TT)	Test Requirement in TS 34.121
7.3 Demodulation of DPCH in multi-path fading propagation conditions Tests 13-16	$\frac{DPCH_E_c}{I_{or}} -2.2 \text{ to } -15.0 \text{ dB}$ $I_{oc} = -60 \text{ dBm}$ $\hat{I}_{or}/I_{oc} = 9 \text{ dB}$	0.1 dB for $\frac{DPCH_E_c}{I_{or}}$ 0.6 dB for \hat{I}_{or}/I_{oc}	Formulas: $\frac{DPCH_E_c}{I_{or}} = \text{Minimum Requirement} +$ TT $\hat{I}_{or}/I_{oc} = \text{Minimum Requirement} + TT$ $I_{oc} \text{ unchanged}$ $\hat{I}_{or}/I_{oc} = 9.6$ $\frac{DPCH_E_c}{I_{or}} = -2.1 \text{ to } -14.9 \text{ dB:}$
7.3 Demodulation of DPCH in multi-path fading propagation conditions Tests 17-20	$\frac{DPCH_E_c}{I_{or}} -1.4 \text{ to } -8.8 \text{ dB}$ $I_{oc} = -60 \text{ dBm}$ $\hat{I}_{or}/I_{oc} = 6 \text{ to } -3 \text{ dB}$	0.1 dB for $\frac{DPCH_E_c}{I_{or}}$ 0.6 dB for \hat{I}_{or}/I_{oc}	Formulas: $\frac{DPCH_E_c}{I_{or}} = \text{Minimum Requirement} +$ TT $\hat{I}_{or}/I_{oc} = \text{Minimum Requirement} + TT$ $I_{oc} \text{ unchanged}$ $\hat{I}_{or}/I_{oc} = 6.6 \text{ to } -2.4 \text{ dB}$ $\frac{DPCH_E_c}{I_{or}} = -1.3 \text{ to } -8.7 \text{ dB:}$
7.4 Demodulation of DPCH in moving propagation conditions	$\frac{DPCH_E_c}{I_{or}} -10.9 \text{ to } -14.5$ $I_{oc} = -60 \text{ dBm}$ $\hat{I}_{or}/I_{oc} = -1 \text{ dB}$	0.1 dB for $\frac{DPCH_E_c}{I_{or}}$ 0.6 dB for \hat{I}_{or}/I_{oc}	Formulas: $\frac{DPCH_E_c}{I_{or}} = \text{Minimum Requirement} +$ TT $\hat{I}_{or}/I_{oc} = \text{Minimum Requirement} + TT$ $I_{oc} \text{ unchanged}$ $\hat{I}_{or}/I_{oc} = -0.4 \text{ dB}$ $\frac{DPCH_E_c}{I_{or}} = -10.8 \text{ to } -14.4 \text{ dB:}$
7.5 Demodulation of DPCH birth-death propagation conditions	$\frac{DPCH_E_c}{I_{or}} -8.7 \text{ to } -12.6 \text{ dB}$ $I_{oc} = -60 \text{ dBm}$ $\hat{I}_{or}/I_{oc} = -1 \text{ dB}$	0.1 dB for $\frac{DPCH_E_c}{I_{or}}$ 0.6 dB for \hat{I}_{or}/I_{oc}	Formulas: $\frac{DPCH_E_c}{I_{or}} = \text{Minimum Requirement} +$ TT $\hat{I}_{or}/I_{oc} = \text{Minimum Requirement} + TT$ $I_{oc} \text{ unchanged}$ $\hat{I}_{or}/I_{oc} = -0.4 \text{ dB}$ $\frac{DPCH_E_c}{I_{or}} = -18.6 \text{ to } -12.5 \text{ dB:}$

Test	Minimum Requirement in TS 25.101	Test Tolerance (TT)	Test Requirement in TS 34.121
7.5A Demodulation of DCH in high speed train conditions	$\frac{DPCH_E_c}{I_{or}} -21.8 \text{ dB}$ $I_{OC} = -60 \text{ dBm}$ $\hat{I}_{or}/I_{oc} = 5 \text{ dB}$	0.1 dB for $\frac{DPCH_E_c}{I_{or}}$ 0.6 dB for \hat{I}_{or}/I_{oc}	Formulas: $\frac{DPCH_E_c}{I_{or}} = \text{Minimum Requirement} +$ TT $\hat{I}_{or}/I_{oc} = \text{Minimum Requirement} + \text{TT}$ $I_{OC} \text{ unchanged}$ $\hat{I}_{or}/I_{oc} = 5.6 \text{ dB}$ $\frac{DPCH_E_c}{I_{or}} = -21.7 \text{ dB:}$
7.6.1 Demodulation of DPCH in transmit diversity propagation conditions	$\frac{DPCH_E_c}{I_{or}} -16.8 \text{ dB}$ $I_{OC} = -60 \text{ dBm}$ $\hat{I}_{or}/I_{oc} = 9 \text{ dB}$	0.1 dB for $\frac{DPCH_E_c}{I_{or}}$ 0.8 dB for \hat{I}_{or}/I_{oc}	Formulas: $\frac{DPCH_E_c}{I_{or}} = \text{Minimum Requirement} +$ TT $\hat{I}_{or}/I_{oc} = \text{Minimum Requirement} + \text{TT}$ $I_{OC} \text{ unchanged}$ $\hat{I}_{or}/I_{oc} = 9.8 \text{ dB}$ $\frac{DPCH_E_c}{I_{or}} = -16.7 \text{ dB:}$
7.6.2 Demodulation of DCH in closed loop Transmit diversity mode	$\frac{DPCH_E_c}{I_{or}} -18 \text{ to } -18.3 \text{ dB}$ $I_{OC} = -60 \text{ dBm}$ $\hat{I}_{or}/I_{oc} = 9 \text{ dB}$	0.1 dB for $\frac{DPCH_E_c}{I_{or}}$ 0.8 dB for \hat{I}_{or}/I_{oc}	Formulas: $\frac{DPCH_E_c}{I_{or}} = \text{Minimum Requirement} +$ TT $\hat{I}_{or}/I_{oc} = \text{Minimum Requirement} + \text{TT}$ $I_{OC} \text{ unchanged}$ $\hat{I}_{or}/I_{oc} = 9.8 \text{ dB}$ $\frac{DPCH_E_c}{I_{or}} = -17.9 \text{ to } -18.2 \text{ dB:}$
7.6.3, Demodulation of DCH in site selection diversity Transmission power control mode	$\frac{DPCH_E_c}{I_{or}} -5.0 \text{ to } -10.5 \text{ dB}$ $I_{OC} = -60 \text{ dBm}$ $\hat{I}_{or}/I_{oc} = 0 \text{ to } -3 \text{ dB}$	0.1 dB for $\frac{DPCH_E_c}{I_{or}}$ 0.8 dB for \hat{I}_{or}/I_{oc}	Formulas: $\frac{DPCH_E_c}{I_{or}} = \text{Minimum Requirement} +$ TT $\hat{I}_{or}/I_{oc} = \text{Minimum Requirement} + \text{TT}$ $I_{OC} \text{ unchanged}$ $\hat{I}_{or}/I_{oc} = 0.8 \text{ to } -2.2 \text{ dB}$ $\frac{DPCH_E_c}{I_{or}} = -4.9 \text{ to } -10.4 \text{ dB:}$

Test	Minimum Requirement in TS 25.101	Test Tolerance (TT)	Test Requirement in TS 34.121
7.7.1 Demodulation in inter-cell soft Handover (Release 5 and earlier)	$\frac{DPCH_E_c}{I_{or}} -5.5 \text{ to } -15.2 \text{ dB}$ $I_{oc} = -60 \text{ dBm}$ $\hat{I}_{or1}/I_{oc} = \hat{I}_{or2}/I_{oc} = 6 \text{ to } 0 \text{ dB}$	0.1 dB for $\frac{DPCH_E_c}{I_{or}}$ 0.6 dB for \hat{I}_{or1}/I_{oc} and \hat{I}_{or2}/I_{oc}	Formulas: $\frac{DPCH_E_c}{I_{or}} = \text{Minimum Requirement} +$ TT $\hat{I}_{or1}/I_{oc} = \text{Minimum Requirement} + \text{TT}$ $\hat{I}_{or2}/I_{oc} = \text{Minimum Requirement} + \text{TT}$ $I_{oc} \text{ unchanged}$ $\hat{I}_{or1}/I_{oc} = \hat{I}_{or2}/I_{oc} = 6.6 \text{ to } 0.6 \text{ dB}$ $\frac{DPCH_E_c}{I_{or}} = -5.4 \text{ to } -15.4 \text{ dB:}$
7.7.1A Demodulation in inter-cell soft Handover (Release 6 and later)	$\frac{DPCH_E_c}{I_{or}} -5.8 \text{ to } -15.2 \text{ dB}$ $I_{oc} = -60 \text{ dBm}$ $\hat{I}_{or1}/I_{oc} = \hat{I}_{or2}/I_{oc} = 6 \text{ to } 0 \text{ dB}$	0.1 dB for $\frac{DPCH_E_c}{I_{or}}$ 0.6 dB for \hat{I}_{or1}/I_{oc} and \hat{I}_{or2}/I_{oc}	Formulas: $\frac{DPCH_E_c}{I_{or}} = \text{Minimum Requirement} +$ TT $\hat{I}_{or1}/I_{oc} = \text{Minimum Requirement} + \text{TT}$ $\hat{I}_{or2}/I_{oc} = \text{Minimum Requirement} + \text{TT}$ $I_{oc} \text{ unchanged}$ $\hat{I}_{or1}/I_{oc} = \hat{I}_{or2}/I_{oc} = 6.6 \text{ to } 0.6 \text{ dB}$ $\frac{DPCH_E_c}{I_{or}} = -5.7 \text{ to } -15.1 \text{ dB:}$
7.7.2 Combining of TPC commands Test 1	$\frac{DPCH_E_c}{I_{or}} -12 \text{ dB}$ $\text{lor1 and lor2 } -60\text{dBm}$	0.1 dB for $\frac{DPCH_E_c}{I_{or}}$ 0dB for lor1 and lor2	Formulas: $\frac{DPCH_E_c}{I_{or}} = \text{Minimum Requirement} +$ TT $\frac{DPCH_E_c}{I_{or}} = -11,9 \text{ dB:}$ $\text{lor1} = -60\text{dBm}$ $\text{lor2} = -60\text{dBm}$ <p>The absolute levels of lor1 and lor2 are not important to this test.</p>

Test	Minimum Requirement in TS 25.101	Test Tolerance (TT)	Test Requirement in TS 34.121
<p>7.7.2 Combining of TPC commands Test 2</p>	<p>$\frac{DPCH_E_c}{I_{or}} -12$ dB</p> <p>$I_{oc} = -60$ dBm</p> <p>$\hat{I}_{or1}/I_{oc} = \hat{I}_{or2}/I_{oc} = 0$ dB</p>	<p>0.1 dB for $\frac{DPCH_E_c}{I_{or}}$</p> <p>0.6 dB for \hat{I}_{or1}/I_{oc} and \hat{I}_{or2}/I_{oc}</p>	<p>Formulas:</p> <p>$\frac{DPCH_E_c}{I_{or}} = \text{Minimum Requirement} +$</p> <p>TT</p> <p>$\hat{I}_{or1}/I_{oc} = \text{Minimum Requirement} + \text{TT}$</p> <p>$\hat{I}_{or2}/I_{oc} = \text{Minimum Requirement} + \text{TT}$</p> <p>$I_{oc}$ unchanged</p> <p>$\hat{I}_{or1}/I_{oc} = \hat{I}_{or2}/I_{oc} = 0.6$ dB</p> <p>$\frac{DPCH_E_c}{I_{or}} = -11,9$ dB:</p>
<p>7.7.3 Combining of reliable TPC commands from radio links of different radio link sets</p>	<p>Test parameters:</p> <p>$\frac{DPCH_E_{c1}}{I_{or1}}$ = set at the level corresponding to 5% TPC error rate.</p> <p>Test 1:</p> <p>$\frac{DPCH_E_{c2}}{I_{or2}} = \frac{DPCH_E_{c1}}{I_{or1}} -10$ dB</p> <p>$\frac{DPCH_E_{c3}}{I_{or3}} = \frac{DPCH_E_{c1}}{I_{or1}} -10$ dB</p> <p>Test 2:</p> <p>$\frac{DPCH_E_{c2}}{I_{or2}} = \frac{DPCH_E_{c1}}{I_{or1}} +6$ dB</p> <p>Test requirements:</p> <p>Test 1: UE output power = -15 dBm ± 5 dB</p> <p>Test 2: UE output power = -15 dBm ± 3 dB</p>	<p>0 dB for all test parameters</p> <p>0 dB for all test requirements</p>	<p>Test parameters:</p> <p>$\frac{DPCH_E_{c1}}{I_{or1}} = \text{Minimum Requirement} +$</p> <p>TT</p> <p>$\frac{DPCH_E_{c2}}{I_{or2}} = \text{Minimum Requirement} +$</p> <p>TT</p> <p>$\frac{DPCH_E_{c3}}{I_{or3}} = \text{Minimum Requirement} +$</p> <p>TT</p> <p>Test requirements:</p> <p>Test 1: UE output power = -15 dBm ± (5 dB + TT)</p> <p>Test 2: UE output power = -15 dBm ± (3 dB + TT)</p>

Test	Minimum Requirement in TS 25.101	Test Tolerance (TT)	Test Requirement in TS 34.121
<p>7.8.1 Power control in downlink constant BLER target</p>	<p>$\frac{DPCH_E_c}{I_{or}}$ -9 to -16 dB</p> <p>$I_{oc} = -60$ dBm</p> <p>$\hat{I}_{or}/I_{oc} = 9$ to -1 dB</p>	<p>0.1 dB for $\frac{DPCH_E_c}{I_{or}}$</p> <p>0.6 dB for \hat{I}_{or}/I_{oc}</p> <p>Alternative $\frac{DPCH_E_c}{I_{or}}$</p> <p>tolerances also apply for test cases using an SS with delayed DL power control response time.</p>	<p>Formulas:</p> <p>$\frac{DPCH_E_c}{I_{or}} = \text{Minimum Requirement} + TT$</p> <p>$\hat{I}_{or}/I_{oc} = \text{Minimum Requirement} + TT$</p> <p>$I_{oc}$ unchanged</p> <p>$\hat{I}_{or}/I_{oc} = 9.6$ to -0.4 dB</p> <p>$\frac{DPCH_E_c}{I_{or}} = -8.9$ to -15.9 dB:</p>
<p>7.8.2, Power control in downlink initial convergence</p>	<p>$\frac{DPCH_E_c}{I_{or}}$ -8.1 to -18.9 dB</p> <p>$I_{oc} = -60$ dBm</p> <p>$\hat{I}_{or}/I_{oc} = -1$ dB</p>	<p>0.6 dB for $\frac{DPCH_E_c}{I_{or}}$</p> <p>power ratio values during T1 and T2.</p> <p>Alternative $\frac{DPCH_E_c}{I_{or}}$</p> <p>tolerance of 0.8 dB applies when using an SS with delayed DL power control response time.</p>	<p>Formulas:</p> <p>DPCH_Ec/Ior during T1 and T2:</p> <p>Minimum Requirement -TT ≤ DPCH_Ec/Ior ≤ Minimum Requirement + TT</p> <p>$\hat{I}_{or}/I_{oc} = \text{unchanged}$</p> <p>$I_{oc}$ unchanged</p>

Test	Minimum Requirement in TS 25.101	Test Tolerance (TT)	Test Requirement in TS 34.121
7.8.3, Power control in downlink: wind up effects	$\frac{DPCH_E_c}{I_{or}} -13.3 \text{ dB}$ $I_{oc} = -60 \text{ dBm}$ $\hat{I}_{or}/I_{oc} = 5 \text{ dB}$	0.1 dB for $\frac{DPCH_E_c}{I_{or}}$ 0.6 dB for \hat{I}_{or}/I_{oc} Alternative $\frac{DPCH_E_c}{I_{or}}$ tolerances also apply for test cases using an SS with delayed DL power control response time.	Formulas: $\frac{DPCH_E_c}{I_{or}} = \text{Minimum Requirement} + TT$ $\hat{I}_{or}/I_{oc} = \text{Minimum Requirement} + TT$ $I_{oc} \text{ unchanged}$ $\hat{I}_{or}/I_{oc} = 5.6 \text{ dB}$ $\frac{DPCH_E_c}{I_{or}} = -13.2 \text{ dB:}$
7.8.4, Power control in the downlink, different transport formats	$\frac{DPCH_E_c}{I_{or}} -16 \text{ to } -18 \text{ dB}$ $I_{oc} = -60 \text{ dBm}$ $\hat{I}_{or}/I_{oc} = 9 \text{ dB}$	0.1 dB for $\frac{DPCH_E_c}{I_{or}}$ 0.6 dB for \hat{I}_{or}/I_{oc} Alternative $\frac{DPCH_E_c}{I_{or}}$ tolerances also apply for test cases using an SS with delayed DL power control response time.	Formulas: $\frac{DPCH_E_c}{I_{or}} = \text{Minimum Requirement} + TT$ $\hat{I}_{or}/I_{oc} = \text{Minimum Requirement} + TT$ $I_{oc} \text{ unchanged}$ $\hat{I}_{or}/I_{oc} = 9.6 \text{ dB}$ $\frac{DPCH_E_c}{I_{or}} = -15.9 \text{ to } -17.9 \text{ dB:}$
7.9 Downlink compressed mode	$\frac{DPCH_E_c}{I_{or}}$ Test 1 -14.6 dB Test 3 -15.2 dB $I_{oc} = -60 \text{ dBm}$ $\hat{I}_{or}/I_{oc} = 9 \text{ dB}$	0.1 dB for $\frac{DPCH_E_c}{I_{or}}$ 0.6 dB for \hat{I}_{or}/I_{oc}	Formulas: $\frac{DPCH_E_c}{I_{or}} = \text{Minimum Requirement} + TT$ $\hat{I}_{or}/I_{oc} = \text{Minimum Requirement} + TT$ $I_{oc} \text{ unchanged}$ $\hat{I}_{or}/I_{oc} = 9.6 \text{ dB}$ $\frac{DPCH_E_c}{I_{or}} =$ Test 1 -14.5 dB Test 3 -15.1 dB:

Test	Minimum Requirement in TS 25.101	Test Tolerance (TT)	Test Requirement in TS 34.121
7.10 Blind transport format detection Tests 1, 2, 3	$\frac{DPCH_E_c}{I_{or}} -17.7 \text{ to } -18.4 \text{ dB}$ $I_{oc} = -60 \text{ dBm}$ $\hat{I}_{or}/I_{oc} = -1 \text{ dB}$	0.1 dB for $\frac{DPCH_E_c}{I_{or}}$ 0.3 dB for \hat{I}_{or}/I_{oc}	Formulas: $\frac{DPCH_E_c}{I_{or}} = \text{Minimum Requirement} + TT$ $\hat{I}_{or}/I_{oc} = \text{Minimum Requirement} + TT$ $I_{oc} \text{ unchanged}$ $\hat{I}_{or}/I_{oc} = -0.7 \text{ dB}$ $\frac{DPCH_E_c}{I_{or}} = -17.6 \text{ to } -18.3 \text{ dB:}$
7.10 Blind transport format detection Tests 4, 5, 6	$\frac{DPCH_E_c}{I_{or}} -13.0 \text{ to } -13.8 \text{ dB}$ $I_{oc} = -60 \text{ dBm}$ $\hat{I}_{or}/I_{oc} = -3 \text{ dB}$	0.1 dB for $\frac{DPCH_E_c}{I_{or}}$ 0.6 dB for \hat{I}_{or}/I_{oc}	Formulas: $\frac{DPCH_E_c}{I_{or}} = \text{Minimum Requirement} + TT$ $\hat{I}_{or}/I_{oc} = \text{Minimum Requirement} + TT$ $I_{oc} \text{ unchanged}$ $\hat{I}_{or}/I_{oc} = -2.4 \text{ dB}$ $\frac{DPCH_E_c}{I_{or}} = -12.9 \text{ to } -13.7 \text{ dB:}$
7.11 Demodulation of paging channel (PCH)	Test 1: $I_{oc} = -60 \text{ dBm}$ $\hat{I}_{or}/I_{oc} = -1 \text{ dB}$ $S\text{-CCPCH_Ec}/I_{or} = -14.8 \text{ dB}$ $PICH_Ec}/I_{or} = -19 \text{ dB}$	Test 1: 0.4 dB for \hat{I}_{or}/I_{oc}	I_{oc} , $S\text{-CCPCH_Ec}/I_{or}$ and $PICH_Ec}/I_{or}$ are unchanged Since PICH Power Offset has to be an integer value TT for $PICH_Ec}/I_{or}$ is zero. But TT of \hat{I}_{or}/I_{oc} has been increased by 0.1 dB from its normal value (0.3 dB / 0.6 dB) due to test system uncertainty of $PICH_Ec}/I_{or}$. Formulas: $\hat{I}_{or}/I_{oc} = \text{Minimum Requirement} + TT$
	Test 2: $I_{oc} = -60 \text{ dBm}$ $\hat{I}_{or}/I_{oc} = -3 \text{ dB}$ $S\text{-CCPCH_Ec}/I_{or} = -9.8 \text{ dB}$ $PICH_Ec}/I_{or} = -12 \text{ dB}$	Test 2: 0.7 dB for \hat{I}_{or}/I_{oc}	
7.12 Detection of acquisition indicator (AI)	$I_{oc} = -60 \text{ dBm}$ $\hat{I}_{or}/I_{oc} = -1 \text{ dB}$ $AICH_Ec}/I_{or} = -22.0 \text{ dB}$ $S\text{-CCPCH_Ec}/I_{or} = -12.0 \text{ dB}$	0.4 dB for \hat{I}_{or}/I_{oc}	I_{oc} and $AICH_Ec}/I_{or}$ are unchanged. Since AICH Power Offset has to be an integer value TT for $AICH_Ec}/I_{or}$ is zero. But TT of \hat{I}_{or}/I_{oc} has been increased by 0.1 dB from its normal value (0.3 dB) due to test system uncertainty of $AICH_Ec}/I_{or}$. No need to add test tolerance to $S\text{-CCPCH_Ec}/I_{or}$ since it is not critical parameter Formula: $\hat{I}_{or}/I_{oc} = \text{Minimum Requirement} + TT$

F.4.4 Requirements for support of RRM

Table F.4.4: Derivation of Test Requirements (RRM tests)

Test	Test Parameters in TS 25.133 [2]	Test Tolerance (TT)	Test Requirement in TS 34.121
8.2 Idle Mode Tasks			
8.2.2 Cell Re-Selection			
8.2.2.1 Scenario 1: Single carrier case	Because the relationships between the Test system uncertainties and the Test Tolerances are complex, it is not possible to give a simple derivation of the Test Requirement in this document. The analysis is recorded in 3GPP TR 34 902 [24].		
	<u>During T1 and T2:</u> Cells 1 and 2: CPICH_Ec/Ior = -10 dB PCCPCH_Ec/Ior = -12 dB SCH_Ec/Ior = -12 dB PICH_Ec/Ior = -15 dB Cells 3, 4, 5, 6: CPICH_Ec/Ior = -10 dB PCCPCH_Ec/Ior = -12 dB SCH_Ec/Ior = -12 dB PICH_Ec/Ior = -15 dB Ior(3, 4, 5, 6) = -69.73 dBm	<u>During T1 and T2:</u> +0.60 dB +0.60 dB +0.60 dB +0.60 dB -0.50 dB -0.50 dB -0.50 dB -0.50 dB +0.03 dB for Ior(3, 4, 5, 6)	<u>During T1 and T2:</u> Ec/Ior Minimum Requirement + TT Ec/Ior Minimum Requirement + TT Ec/Ior Minimum Requirement + TT Ec/Ior Minimum Requirement + TT Ec/Ior Minimum Requirement + TT Ec/Ior Minimum Requirement + TT Ec/Ior Minimum Requirement + TT Ec/Ior Minimum Requirement + TT Ior(3, 4, 5, 6) Minimum Requirement + TT
	<u>During T1:</u> Ior(1) = -62.73 dBm Ior(2) = -59.73 dBm	<u>During T1:</u> -0.27 dB for Ior(1) +0.13 dB for Ior(2)	<u>During T1:</u> Ior(1) Minimum Requirement + TT Ior(2) Minimum Requirement + TT
	<u>During T2:</u> Ior(1) = -59.73 dBm Ior(2) = -62.73 dBm	<u>During T2:</u> +0.13 dB for Ior(1) -0.27 dB for Ior(2)	<u>During T2:</u> Ior(1) Minimum Requirement + TT Ior(2) Minimum Requirement + TT
8.2.2.2 Scenario 2: Multi carrier case	Because the relationships between the Test system uncertainties and the Test Tolerances are complex, it is not possible to give a simple derivation of the Test Requirement in this document. The analysis is recorded in 3GPP TR 34 902 [24].		

Test	Test Parameters in TS 25.133 [2]	Test Tolerance (TT)	Test Requirement in TS 34.121
	<p><u>Channel 1 during T1 and T2:</u></p> <p>Cell 1: CPICH_Ec/Ior = -10 dB PCCPCH_Ec/Ior = -12 dB SCH_Ec/Ior = -12 dB PICH_Ec/Ior = -15 dB</p> <p>Cells 3 and 4: CPICH_Ec/Ior = -10 dB PCCPCH_Ec/Ior = -12 dB SCH_Ec/Ior = -12 dB PICH_Ec/Ior = -15 dB</p>	<p><u>Channel 1 during T1 and T2:</u></p> <p>+0.70 dB +0.70 dB +0.70 dB +0.70 dB</p> <p>-0.80 dB -0.80 dB -0.80 dB -0.80 dB</p>	<p><u>Channel 1 during T1 and T2:</u></p> <p>Ec/Ior Minimum Requirement + TT Ec/Ior Minimum Requirement + TT Ec/Ior Minimum Requirement + TT Ec/Ior Minimum Requirement + TT Ec/Ior Minimum Requirement + TT Ec/Ior Minimum Requirement + TT Ec/Ior Minimum Requirement + TT Ec/Ior Minimum Requirement + TT</p>
	<p><u>Channel 1 during T1:</u></p> <p>Ior(1) = -73.39 dBm Ior(3, 4) = -77.39 dBm Ioc(1) = -70.00 dBm</p>	<p><u>Channel 1 during T1:</u></p> <p>-0.01 dB for Ior(1) -0.01 dB for Ior(3,4) 0.00 dB for Ioc(1)</p>	<p><u>Channel 1 during T1:</u></p> <p>Ior(1) Minimum Requirement + TT Ior(3, 4) Minimum Requirement + TT Ioc(1) Minimum Requirement + TT</p>
	<p><u>Channel 1 during T2:</u></p> <p>Ior(1) = -67.75 dBm Ior(3, 4) = -74.75 dBm Ioc(1) = -70.00 dBm</p>	<p><u>Channel 1 during T2:</u></p> <p>+0.75 dB for Ior(1) -0.05 dB for Ior(3, 4) -1.80 dB for Ioc(1)</p>	<p><u>Channel 1 during T2:</u></p> <p>Ior(1) Minimum Requirement + TT Ior(3, 4) Minimum Requirement + TT Ioc(1) Minimum Requirement + TT</p>
	<p><u>Channel 2 during T1 and T2:</u></p> <p>Cell 2: CPICH_Ec/Ior = -10 dB PCCPCH_Ec/Ior = -12 dB SCH_Ec/Ior = -12 dB PICH_Ec/Ior = -15 dB</p> <p>Cells 5 and 6: CPICH_Ec/Ior = -10 dB PCCPCH_Ec/Ior = -12 dB SCH_Ec/Ior = -12 dB PICH_Ec/Ior = -15 dB</p>	<p><u>Channel 2 during T1 and T2:</u></p> <p>+0.70 dB +0.70 dB +0.70 dB +0.70 dB</p> <p>-0.80 dB -0.80 dB -0.80 dB -0.80 dB</p>	<p><u>Channel 2 during T1 and T2:</u></p> <p>Ec/Ior Minimum Requirement + TT Ec/Ior Minimum Requirement + TT Ec/Ior Minimum Requirement + TT Ec/Ior Minimum Requirement + TT Ec/Ior Minimum Requirement + TT Ec/Ior Minimum Requirement + TT Ec/Ior Minimum Requirement + TT Ec/Ior Minimum Requirement + TT</p>

Test	Test Parameters in TS 25.133 [2]	Test Tolerance (TT)	Test Requirement in TS 34.121
	<u>Channel 2 during T1:</u> lor(2) = -67.75 dBm lor(5, 6) = -74.75 dBm loc(2) = -70.00 dBm	<u>Channel 2 during T1:</u> +0.75 dB for lor(2) -0.05 dB for lor(5, 6) -1.80 dB for loc(2)	<u>Channel 2 during T1:</u> Minimum Requirement (lor(2)) + TT Minimum Requirement (lor(5, 6)) + TT Minimum Requirement (loc(2)) + TT
	<u>Channel 2 during T2:</u> lor(2) = -73.39 dBm lor(5, 6) = -77.39 dBm loc(2) = -70.00 dBm	<u>Channel 2 during T2:</u> -0.01 dB for lor(2) -0.01 dB for lor(5,6) 0.00 dB for loc(2)	<u>Channel 2 during T2:</u> lor(2) Minimum Requirement + TT lor(5, 6) Minimum Requirement + TT loc(2) Minimum Requirement + TT
8.2.3 UTRAN to GSM Cell Re-Selection			
8.2.3.1 Scenario 1: Both UTRA and GSM level changed	During T1: $\frac{CPICH_E_c}{I_{or}} = -10\text{ dB}$ lor/loc = 0 dB RXLEV=-90 dBm	During T1: 0.1 dB for $\frac{CPICH_E_c}{I_{or}}$ 0.3 dB for lor/loc 1.0 dB for RXLEV	During T1: Formulas: $\frac{CPICH_E_c}{I_{or}} = \text{Minimum Requirement} + TT$ lor/loc = Minimum Requirement + TT RXLEV - TT lor/loc = 0.3 dB $\frac{CPICH_E_c}{I_{or}} = -9.9\text{ dB:}$ Measured GSM Carrier RSSI ± uncertainty of RXLEV setting shall be below -90 dBm (Threshold for GSM).
	During T2: $\frac{CPICH_E_c}{I_{or}} = -10\text{ dB}$ lor/loc = - 5 dB RXLEV=-75 dBm	During T2: 0.1 dB for $\frac{CPICH_E_c}{I_{or}}$ 0.3 dB for lor/loc 1.0 dB for RXLEV	During T2: Formulas: $\frac{CPICH_E_c}{I_{or}} = \text{Minimum Requirement} - TT$ lor/loc = Minimum Requirement - TT RXLEV + TT lor/loc = -5.3 dB $\frac{CPICH_E_c}{I_{or}} = -10.1\text{ dB:}$ Measured GSM Carrier RSSI ± uncertainty of RXLEV setting shall be above -75 dBm (Threshold for GSM).

Test	Test Parameters in TS 25.133 [2]	Test Tolerance (TT)	Test Requirement in TS 34.121
8.2.3.2 Scenario 2: Only UTRA level changed	During T1: $\frac{CPICH_E_c}{I_{or}} = -10 \text{ dB}$ lor/loc = 20 dB RXLEV=-80 dBm	During T1: 0.1 dB for $\frac{CPICH_E_c}{I_{or}}$ 0.3 dB for lor/loc 1.0 dB for RXLEV	During T1: Formulas: $\frac{CPICH_E_c}{I_{or}} = \text{Minimum Requirement} + \text{TT}$ lor/loc = Minimum Requirement + TT RXLEV - TT lor/loc = 20.3 dB $\frac{CPICH_E_c}{I_{or}} = -9.9 \text{ dB}$: Measured GSM Carrier RSSI ± uncertainty of RXLEV setting shall be below -80 dBm (Threshold for GSM).
	During T2: $\frac{CPICH_E_c}{I_{or}} = -10 \text{ dB}$ lor/loc = -9 dB RXLEV=-80 dBm	During T2: 0.1 dB for $\frac{CPICH_E_c}{I_{or}}$ 0.3 dB for lor/loc 1.0 dB for RXLEV	During T2: Formulas: $\frac{CPICH_E_c}{I_{or}} = \text{Minimum Requirement} - \text{TT}$ lor/loc = Minimum Requirement - TT RXLEV + TT lor/loc = -9.3 dB $\frac{CPICH_E_c}{I_{or}} = -10.1 \text{ dB}$: Measured GSM Carrier RSSI ± uncertainty of RXLEV setting shall be above -80 dBm (Threshold for GSM).
8.2.3.3 Scenario 3: HCS with only UTRA level changed	$\frac{CPICH_E_c}{I_{or}} = -10 \text{ dB}$ lor/loc = 30 dB	0.1 dB for $\frac{CPICH_E_c}{I_{or}}$ 0.3 dB for lor/loc 1.0 dB for RXLEV	Formulas: $\frac{CPICH_E_c}{I_{or}} = \text{Minimum Requirement} + \text{TT}$ lor/loc = Minimum Requirement + TT RXLEV + TT lor/loc = 30.3 dB $\frac{CPICH_E_c}{I_{or}} = -9.9 \text{ dB}$:

Test	Test Parameters in TS 25.133 [2]	Test Tolerance (TT)	Test Requirement in TS 34.121
	$\frac{CPICH_E_c}{I_{or}} = -10 \text{ dB}$ lor/loc = 10 dB	0.1 dB for $\frac{CPICH_E_c}{I_{or}}$ 0.3 dB for lor/loc 1.0 dB for RXLEV	Formulas: $\frac{CPICH_E_c}{I_{or}} = \text{ratio} - \text{TT}$ lor/loc = ratio - TT RXLEV + TT lor/loc = 9.7 dB $\frac{CPICH_E_c}{I_{or}} = -10.1 \text{ dB}$
8.2.4 FDD/TDD cell re-selection	TBD		
8.3 UTRAN Connected Mode Mobility	TBD		
8.3.1 FDD/FDD Soft Handover	Because the relationships between the Test system uncertainties and the Test Tolerances are complex, it is not possible to give a simple derivation of the Test Requirement in this document. The analysis is recorded in 3GPP TR 34 902 [24].		
	<u>During T0/T1 and T2/T3/T4/T5/T6:</u> Cell 1: CPICH_Ec/lor = -10 dB PCCPCH_Ec/lor = -12 dB SCH_Ec/lor = -12 dB PICH_Ec/lor = -15 dB Relative delay of paths received from cell 2 with respect to cell 1 = {-148 ... 148} chips	<u>During T0/T1 and T2/T3/T4/T5/T6:</u> +0.70 dB +0.70 dB +0.70 dB +0.70 dB 0.5 chips	<u>During T0/T1 and T2/T3/T4/T5/T6:</u> Ec/lor Minimum Requirement + TT Ec/lor Minimum Requirement + TT Ec/lor Minimum Requirement + TT Ec/lor Minimum Requirement + TT {-148+TT ... 148-TT} chips
	<u>During T0/T1:</u> Already covered above	<u>During T0/T1:</u> Covered above	<u>During T0/T1:</u> Already covered above
	<u>During T2/T3/T4/T5/T6:</u> Cell 2: CPICH_Ec/lor = -10 dB PCCPCH_Ec/lor = -12 dB SCH_Ec/lor = -12 dB PICH_Ec/lor = -15 dB	<u>During T2/T3/T4/T5/T6:</u> +0.70 dB +0.70 dB +0.70 dB +0.70 dB	<u>During T2/T3/T4/T5/T6:</u> Ec/lor Minimum Requirement + TT Ec/lor Minimum Requirement + TT Ec/lor Minimum Requirement + TT Ec/lor Minimum Requirement + TT
8.3.2 FDD/FDD Hard Handover			
8.3.2.1 Handover to intra-frequency cell	Because the relationships between the Test system uncertainties and the Test Tolerances are complex, it is not possible to give a simple derivation of the Test Requirement in this document. The analysis is recorded in 3GPP TR 34 902 [24].		
	<u>During T1 and T2 / T3:</u> Cell 1: CPICH_Ec/lor = -10 dB PCCPCH_Ec/lor = -12 dB SCH_Ec/lor = -12 dB PICH_Ec/lor = -15 dB	<u>During T1 / T2 / T3:</u> +0.70 dB +0.70 dB +0.70 dB +0.70 dB	<u>During T1 and T2 / T3:</u> Ec/lor Minimum Requirement + TT Ec/lor Minimum Requirement + TT Ec/lor Minimum Requirement + TT Ec/lor Minimum Requirement + TT

Test	Test Parameters in TS 25.133 [2]	Test Tolerance (TT)	Test Requirement in TS 34.121
	<u>During T1:</u> Already covered above	<u>During T1:</u> Covered above	<u>During T1:</u> Already covered above
	<u>During T2 / T3:</u> Cell 2: CPICH_Ec/Ior = -10 dB PCCPCH_Ec/Ior = -12 dB SCH_Ec/Ior = -12 dB PICH_Ec/Ior = -15 dB	<u>During T2 / T3:</u> +0.70 dB +0.70 dB +0.70 dB +0.70 dB	<u>During T2 / T3:</u> Ec/Ior Minimum Requirement + TT Ec/Ior Minimum Requirement + TT Ec/Ior Minimum Requirement + TT Ec/Ior Minimum Requirement + TT
8.3.2.2 Handover to inter-frequency cell	Because the relationships between the Test system uncertainties and the Test Tolerances are complex, it is not possible to give a simple derivation of the Test Requirement in this document. The analysis is recorded in 3GPP TR 34 902 [24].		
	<u>Channel 1 during T1 and T2 / T3:</u> Cell 1: CPICH_Ec/Ior = -10 dB PCCPCH_Ec/Ior = -12 dB SCH_Ec/Ior = -12 dB PICH_Ec/Ior = -15 dB	<u>Channel 1 during T1 and T2 / T3:</u> +0.80 dB +0.80 dB +0.80 dB +0.80 dB	<u>Channel 1 during T1 and T2 / T3:</u> Ec/Ior Minimum Requirement + TT Ec/Ior Minimum Requirement + TT Ec/Ior Minimum Requirement + TT Ec/Ior Minimum Requirement + TT
	<u>Channel 2 during T1:</u> Not applicable	<u>Channel 2 during T1:</u> Not applicable	<u>Channel 2 during T1:</u> Not applicable
	<u>Channel 2 during T2 / T3:</u> Cell 2: CPICH_Ec/Ior = -10 dB PCCPCH_Ec/Ior = -12 dB SCH_Ec/Ior = -12 dB PICH_Ec/Ior = -15 dB	<u>Channel 2 during T2 / T3:</u> +0.80 dB +0.80 dB +0.80 dB +0.80 dB	<u>Channel 2 during T2 / T3:</u> Ec/Ior Minimum Requirement + TT Ec/Ior Minimum Requirement + TT Ec/Ior Minimum Requirement + TT Ec/Ior Minimum Requirement + TT
8.3.3 FDD/TDD Handover	TBD		
8.3.4 Inter-system Handover form UTRAN FDD to GSM	During T2 and T3 RXLEV=-75 dBm	<u>During T2 and T3:</u> + 1 dB for RXLEV	During T2 and T3 Minimum Requirement + TT Only RXLEV during T2 and T3 is a critical parameter. UE measurement accuracy for GSM Carrier RSSI is ± 4 dB in this test. During T2 and T3 : measured GSM Carrier RSSI \pm uncertainty of RXLEV setting shall be above -80 dBm (Threshold for GSM). => TT=+1 dB for RXLEV
8.3.5 Cell Re-selection in CELL_FACH			

Test	Test Parameters in TS 25.133 [2]	Test Tolerance (TT)	Test Requirement in TS 34.121
8.3.5.1 One frequency present in the neighbour list	Because the relationships between the Test system uncertainties and the Test Tolerances are complex, it is not possible to give a simple derivation of the Test Requirement in this document. The analysis is recorded in 3GPP TR 34 902 [24].		
	<u>During T1 and T2:</u> Cells 1 and 2: CPICH_Ec/Ior = -10 dB PCCPCH_Ec/Ior = -12 dB SCH_Ec/Ior = -12 dB PICH_Ec/Ior = -15 dB S-CCPCH_Ec/Ior = -12 dB Cells 3, 4, 5, 6: CPICH_Ec/Ior = -10 dB PCCPCH_Ec/Ior = -12 dB SCH_Ec/Ior = -12 dB PICH_Ec/Ior = -15 dB S-CCPCH_Ec/Ior = -12 dB Ior(3, 4, 5, 6) = -69.73 dBm	<u>During T1 and T2:</u> +0.60 dB +0.60 dB +0.60 dB +0.60 dB +0.60 dB -0.50 dB -0.50 dB -0.50 dB -0.50 dB -0.50 dB +0.03 dB for Ior(3, 4, 5, 6)	<u>During T1 and T2:</u> Ec/Ior Minimum Requirement + TT Ec/Ior Minimum Requirement + TT Ec/Ior Minimum Requirement + TT Ec/Ior Minimum Requirement + TT Ec/Ior Minimum Requirement + TT Ec/Ior Minimum Requirement + TT Ec/Ior Minimum Requirement + TT Ec/Ior Minimum Requirement + TT Ec/Ior Minimum Requirement + TT Ec/Ior Minimum Requirement + TT Ior(3, 4, 5, 6) Minimum Requirement + TT
	<u>During T1:</u> Ior(1) = -62.73 dBm Ior(2) = -59.73 dBm	<u>During T1:</u> -0.27 dB for Ior(1) +0.13 dB for Ior(2)	<u>During T1:</u> Minimum Requirement (Ior(1)) + TT Minimum Requirement (Ior(2)) + TT
	<u>During T2:</u> Ior(1) = -59.73 dBm Ior(2) = -62.73 dBm	<u>During T2:</u> +0.13 dB for Ior(1) -0.27 dB for Ior(2)	<u>During T2:</u> Ior(1) Minimum Requirement + TT Ior(2) Minimum Requirement + TT
8.3.5.2 Two frequencies present in the neighbour list	Because the relationships between the Test system uncertainties and the Test Tolerances are complex, it is not possible to give a simple derivation of the Test Requirement in this document. The analysis is recorded in 3GPP TR 34 902 [24].		

Test	Test Parameters in TS 25.133 [2]	Test Tolerance (TT)	Test Requirement in TS 34.121
	<p><u>Channel 1 during T1 and T2:</u></p> <p>Cell 1: CPICH_Ec/Ior = -10 dB PCCPCH_Ec/Ior = -12 dB SCH_Ec/Ior = -12 dB PICH_Ec/Ior = -15 dB S-CCPCH_Ec/Ior = -12 dB</p> <p>Cells 3 and 4: CPICH_Ec/Ior = -10 dB PCCPCH_Ec/Ior = -12 dB SCH_Ec/Ior = -12 dB PICH_Ec/Ior = -15 dB S-CCPCH_Ec/Ior = -12 dB</p>	<p><u>Channel 1 during T1 and T2:</u></p> <p>+0.60 dB +0.60 dB +0.60 dB +0.60 dB +0.60 dB</p> <p>-0.70 dB -0.70 dB -0.70 dB -0.70 dB -0.70 dB</p>	<p><u>Channel 1 during T1 and T2:</u></p> <p>Ec/Ior Minimum Requirement + TT Ec/Ior Minimum Requirement + TT Ec/Ior Minimum Requirement + TT Ec/Ior Minimum Requirement + TT Ec/Ior Minimum Requirement + TT Ec/Ior Minimum Requirement + TT Ec/Ior Minimum Requirement + TT Ec/Ior Minimum Requirement + TT Ec/Ior Minimum Requirement + TT Ec/Ior Minimum Requirement + TT Ec/Ior Minimum Requirement + TT Ec/Ior Minimum Requirement + TT</p>
	<p><u>Channel 1 during T1:</u></p> <p>Ior(1) = -71.85 dBm Ior(3, 4) = -76.85 dBm Ioc(1) = -70.00 dBm</p>	<p><u>Channel 1 during T1:</u></p> <p>+0.05 dB for Ior(1) +0.05 dB for Ior(3,4) 0.00 dB for Ioc(1)</p>	<p><u>Channel 1 during T1:</u></p> <p>Ior(1) Minimum Requirement + TT Ior(3, 4) Minimum Requirement + TT Ioc(1) Minimum Requirement + TT</p>
	<p><u>Channel 1 during T2:</u></p> <p>Ior(1) = -67.75 dBm Ior(3, 4) = -74.75 dBm Ioc(1) = -70.00 dBm</p>	<p><u>Channel 1 during T2:</u></p> <p>+0.75 dB for Ior(1) -0.05 dB for Ior(3, 4) -1.60 dB for Ioc(1)</p>	<p><u>Channel 1 during T2:</u></p> <p>Ior(1) Minimum Requirement + TT Ior(3, 4) Minimum Requirement + TT Ioc(1) Minimum Requirement + TT</p>

Test	Test Parameters in TS 25.133 [2]	Test Tolerance (TT)	Test Requirement in TS 34.121
	<p><u>Channel 2 during T1 and T2:</u></p> <p>Cell 2: CPICH_Ec/Ior = -10 dB PCCPCH_Ec/Ior = -12 dB SCH_Ec/Ior = -12 dB PICH_Ec/Ior = -15 dB S-CCPCH_Ec/Ior = -12 dB</p> <p>Cells 5 and 6: CPICH_Ec/Ior = -10 dB PCCPCH_Ec/Ior = -12 dB SCH_Ec/Ior = -12 dB PICH_Ec/Ior = -15 dB S-CCPCH_Ec/Ior = -12 dB</p>	<p><u>Channel 2 during T1 and T2:</u></p> <p>+0.60 dB +0.60 dB +0.60 dB +0.60 dB +0.60 dB</p> <p>-0.70 dB -0.70 dB -0.70 dB -0.70 dB -0.70 dB</p>	<p><u>Channel 2 during T1 and T2:</u></p> <p>Ec/Ior Minimum Requirement + TT Ec/Ior Minimum Requirement + TT Ec/Ior Minimum Requirement + TT Ec/Ior Minimum Requirement + TT Ec/Ior Minimum Requirement + TT Ec/Ior Minimum Requirement + TT Ec/Ior Minimum Requirement + TT Ec/Ior Minimum Requirement + TT Ec/Ior Minimum Requirement + TT Ec/Ior Minimum Requirement + TT Ec/Ior Minimum Requirement + TT</p>
	<p><u>Channel 2 during T1:</u></p> <p>Ior(2) = -67.75 dBm Ior(5, 6) = -74.75 dBm Ioc(2) = -70.00 dBm</p>	<p><u>Channel 2 during T1:</u></p> <p>+0.75 dB for Ior(2) -0.05 dB for Ior(5, 6) -1.60 dB for Ioc(2)</p>	<p><u>Channel 2 during T1:</u></p> <p>Ior(2) Minimum Requirement + TT Ior(5, 6) Minimum Requirement + TT Ioc(2) Minimum Requirement + TT</p>
	<p><u>Channel 2 during T2:</u></p> <p>Ior(2) = -71.85 dBm Ior(5, 6) = -76.85 dBm Ioc(2) = -70.00 dBm</p>	<p><u>Channel 2 during T2:</u></p> <p>+0.05 dB for Ior(2) +0.05 dB for Ior(5,6) 0.00 dB for Ioc(2)</p>	<p><u>Channel 2 during T2:</u></p> <p>Ior(2) Minimum Requirement + TT Ior(5, 6) Minimum Requirement + TT Ioc(2) Minimum Requirement + TT</p>
<p>8.3.5.3 Cell Re-selection to GSM</p>	<p><u>During T1:</u></p> <p>$\frac{CPICH_E_c}{I_{or}} = -10$ dB</p> <p>Ior/Ioc = 0 dB</p> <p>RXLEV=-90 dBm</p> <p>Ioc/RXLEV = 20</p>	<p><u>During T1:</u></p> <p>0.1 dB for $\frac{CPICH_E_c}{I_{or}}$</p> <p>0.3 dB for Ior/Ioc</p> <p>1.0 dB for RXLEV</p>	<p><u>During T1:</u></p> <p>$\frac{CPICH_E_c}{I_{or}} =$ Minimum Requirement + TT</p> <p>Ior/Ioc = Minimum Requirement + TT</p> <p>RXLEV - TT</p> <p>Ior/Ioc = 0.3 dB</p> <p>$\frac{CPICH_E_c}{I_{or}} = -9.9$ dB:</p> <p>Measured GSM Carrier RSSI ± uncertainty of RXLEV setting shall be below -90 dBm (Threshold for GSM).</p>

Test	Test Parameters in TS 25.133 [2]	Test Tolerance (TT)	Test Requirement in TS 34.121
	<p><u>During T2:</u></p> $\frac{CPICH_E_c}{I_{or}} = -10 \text{ dB}$ <p>lor/loc = - 5 dB</p> <p>RXLEV=-75 dBm</p> <p>loc/RXLEV = 5</p>	<p><u>During T2:</u></p> <p>0.1 dB for $\frac{CPICH_E_c}{I_{or}}$</p> <p>0.3 dB for lor/loc</p> <p>1.0 dB for RXLEV</p>	<p><u>During T2:</u></p> $\frac{CPICH_E_c}{I_{or}} = \text{Minimum}$ <p>Requirement - TT</p> <p>lor/loc = Minimum Requirement - TT</p> <p>RXLEV + TT</p> <p>lor/loc = -5.3 dB</p> $\frac{CPICH_E_c}{I_{or}} = -10.1 \text{ dB:}$ <p>Measured GSM Carrier RSSI ± uncertainty of RXLEV setting shall be above -75 dBm (Threshold for GSM).</p>
8.3.6 Cell Re-selection in CELL_PCH			
8.3.6.1 One frequency present in the neighbour list	<p>Same as 8.2.2.1</p> $\frac{CPICH_E_c}{I_{or}} = -10 \text{ dB}$ <p>$I_{oc} = - 70 \text{ dBm}$</p> <p>lor/loc = 10.27 dB</p> <p>Note: Parameters are valid for cell 1 at time T2 and cell 2 at time T1</p>	<p>Same as 8.2.2.1</p> <p>0.1 dB for $\frac{CPICH_E_c}{I_{or}}$</p> <p>0.3 dB for lor/loc</p>	<p>Same as 8.2.2.1</p> <p>Formulas:</p> $\frac{CPICH_E_c}{I_{or}} = \text{Minimum}$ <p>Requirement + TT</p> <p>lor/loc = Minimum Requirement + TT</p> <p>loc unchanged</p> <p>lor/loc = 10.57 dB</p> $\frac{CPICH_E_c}{I_{or}} = -9.9 \text{ dB:}$
8.3.6.2 Two frequencies present in the neighbour list	<p>Same as 8.2.2.2</p> $\frac{CPICH_E_c}{I_{or}} = -10 \text{ dB}$ <p>$I_{oc} = - 70 \text{ dBm}$</p> <p>lor/loc = 2.2 dB</p> <p>Note: Parameters are valid for cell 1 at time T2 and cell 2 at time T1</p>	<p>Same as 8.2.2.2</p> <p>0.1 dB for $\frac{CPICH_E_c}{I_{or}}$</p> <p>0.3 dB for lor/loc</p>	<p>Same as 8.2.2.2</p> <p>Formulas:</p> $\frac{CPICH_E_c}{I_{or}} = \text{Minimum}$ <p>Requirement + TT</p> <p>lor/loc = Minimum Requirement + TT</p> <p>loc unchanged</p> <p>loc ratio unchanged</p> <p>lor/loc = 2.5 dB</p> $\frac{CPICH_E_c}{I_{or}} = -9.9 \text{ dB:}$

Test	Test Parameters in TS 25.133 [2]	Test Tolerance (TT)	Test Requirement in TS 34.121
8.3.6.3 Cell re-selection during an MBMS session, one UTRAN inter-frequency and 2 GSM cells present in the neighbour list	TBD	TBD	TBD
8.3.7 Cell Re-selection in URA_PCH			
8.3.7.1 One frequency present in the neighbour list	Same as 8.2.2.1	Same as 8.2.2.1	Same as 8.2.2.1
8.3.7.2 Two frequencies present in the neighbour list	Same as 8.2.2.2	Same as 8.2.2.2	Same as 8.2.2.2
8.3.8 Serving HS-DSCH cell change	Because the relationships between the Test system uncertainties and the Test Tolerances are complex, it is not possible to give a simple derivation of the Test Requirement in this document. The analysis is recorded in 3GPP TR 34 902 [24].		
	<u>During T0/T1/T2/T3:</u>	<u>During T0/T1/T2/T3:</u>	<u>During T0/T1/T2/T3:</u>
	Cell 1: CPICH_Ec/Ior = -10 dB PCCPCH_Ec/Ior = -12 dB SCH_Ec/Ior = -12 dB PICH_Ec/Ior = -15 dB HS-PDSCH_Ec/Ior = -10 dB HS-SCCH_Ec/Ior = -13 dB Cell 2: CPICH_Ec/Ior = -10 dB PCCPCH_Ec/Ior = -12 dB SCH_Ec/Ior = -12 dB PICH_Ec/Ior = -15 dB Relative delay of paths received from cell 2 with respect to cell 1 = {-148 ... 148} chips	+0.70 dB +0.70 dB +0.70 dB +0.70 dB +0.70 dB +0.70 dB +0.70 dB +0.70 dB +0.70 dB +0.70 dB 0.5 chips	Ec/Ior Minimum Requirement + TT Ec/Ior Minimum Requirement + TT Ec/Ior Minimum Requirement + TT Ec/Ior Minimum Requirement + TT Ec/Ior Minimum Requirement + TT Ec/Ior Minimum Requirement + TT Ec/Ior Minimum Requirement + TT Ec/Ior Minimum Requirement + TT Ec/Ior Minimum Requirement + TT Ec/Ior Minimum Requirement + TT Ec/Ior Minimum Requirement + TT {-148+TT ... 148-TT} chips
	<u>During T0</u>	<u>During T0</u>	<u>During T0</u>
Already covered above	Covered above	Already covered above	
	<u>During T1/T2/T3</u>	<u>During T1/T2/T3</u>	<u>During T1/T2/T3</u>
	Cell 2: CPICH_Ec/Ior = -10 dB PCCPCH_Ec/Ior = -12 dB SCH_Ec/Ior = -12 dB PICH_Ec/Ior = -15 dB	+0.70 dB +0.70 dB +0.70 dB +0.70 dB	Ec/Ior Minimum Requirement + TT Ec/Ior Minimum Requirement + TT Ec/Ior Minimum Requirement + TT Ec/Ior Minimum Requirement + TT

Test	Test Parameters in TS 25.133 [2]	Test Tolerance (TT)	Test Requirement in TS 34.121
	<u>During T4:</u> Cell 1: CPICH_Ec/Ior = -10 dB PCCPCH_Ec/Ior = -12 dB SCH_Ec/Ior = -12 dB PICH_Ec/Ior = -15 dB Cell 2: CPICH_Ec/Ior = -10 dB PCCPCH_Ec/Ior = -12 dB SCH_Ec/Ior = -12 dB PICH_Ec/Ior = -15 dB HS-PDSCH_Ec/Ior = -10 dB HS-SCCH_Ec/Ior = -13 dB Relative delay of paths received from cell 2 with respect to cell 1 = {-148 ... 148} chips	<u>During T4:</u> +0.70 dB +0.70 dB +0.70 dB +0.70 dB +0.70 dB +0.70 dB +0.70 dB +0.70 dB +0.70 dB +0.70 dB 0.5 chips	<u>During T4:</u> Ec/Ior Minimum Requirement + TT Ec/Ior Minimum Requirement + TT Ec/Ior Minimum Requirement + TT Ec/Ior Minimum Requirement + TT Ec/Ior Minimum Requirement + TT Ec/Ior Minimum Requirement + TT Ec/Ior Minimum Requirement + TT Ec/Ior Minimum Requirement + TT Ec/Ior Minimum Requirement + TT Ec/Ior Minimum Requirement + TT Ec/Ior Minimum Requirement + TT Ec/Ior Minimum Requirement + TT {-148+TT ... 148-TT} chips
8.4 RRC Connection Control			
8.4.1 RRC Re-establishment delay	TBD		
8.4.1.1 Test 1	Cell 1, T1: CPICH_Ec/Ior = -10 dB PCCPCH_Ec/Ior = -12 dB SCH_Ec/Ior = -12 dB PICH_Ec/Ior = -15 dB DCH_Ec/Ior = -17 dB Ior/Ioc = 2.39 dB Cell 1, T2: Ior/Ioc = -infinity Cell 2, T1: CPICH_Ec/Ior = -10 dB PCCPCH_Ec/Ior = -12 dB SCH_Ec/Ior = -12 dB PICH_Ec/Ior = -15 dB Ior/Ioc = 4.39 dB Cell 2, T2: CPICH_Ec/Ior = -10 dB PCCPCH_Ec/Ior = -12 dB SCH_Ec/Ior = -12 dB PICH_Ec/Ior = -15 dB Ior/Ioc = 0.02 dB	0.1 dB for $\frac{CPICH_E_c}{I_{or}}$ 0.3 dB for Ior/Ioc	Level settings in either direction are not critical with respect to the outcome of the test.

Test	Test Parameters in TS 25.133 [2]	Test Tolerance (TT)	Test Requirement in TS 34.121
8.4.1.2 Test 2	Cell 1, T1: CPICH_Ec/lor = -10 dB PCCPCH_Ec/lor = -12 dB SCH_Ec/lor = -12 dB PICH_Ec/lor = -15 dB DCH_Ec/lor = -17 dB lor/loc = -3.35 dB Cell 1, T2: lor/loc = -infinity Cell 2, T1: lor/loc = -infinity Cell 2, T2: CPICH_Ec/lor = -10 dB PCCPCH_Ec/lor = -12 dB SCH_Ec/lor = -12 dB PICH_Ec/lor = -15 dB lor/loc = 0.02 dB	0.1 dB for $\frac{CPICH_Ec}{I_{or}}$ 0.3 dB for lor/loc	Level settings in either direction are not critical with respect to the outcome of the test.
8.4.2 Random Access	PRACH power difference nominal 3dB ± 2dB UE setting uncertainty	Measurement TT: Power difference ± 1dB Maximum Power-1dB / +0.7dB	Test parameter settings unchanged. Power measurement: Upper limit + TT Lower limit - TT
8.4.2.1A Correct behaviour when receiving an ACK (Release 6 and later)	PRACH timing error ± 3.5 chips	0.5 chips	Formula: Upper limit + TT Lower limit - TT
8.4.2.4 Random Access correct behavior when reaching maximum transmit power	Maximum preamble power = 0dBm ± 9dB (Normal) Maximum preamble power = 0dBm ± 12dB (Extreme)	1.0 dB	Formula: Upper limit + TT Lower limit - TT For Normal conditions: Upper Tolerance limit = +10 dB Lower Tolerance limit = -10 dB For Extreme conditions: Upper Tolerance limit = +13 dB Lower Tolerance limit = -13 dB
8.4.3 Transport format combination selection in UE	DL Power control is ON so DPCH_Ec/lor depends on TPC commands sent by UE	0 dB for DPCH_Ec/lor	No test requirements for DPCH_Ec/lor
8.4.4 E-TFC restriction in UE			
8.4.4.1 10ms TTI E-DCH E-TFC restriction	$\frac{E_c}{I_{or}}$ -3.47, -10, -31dB $\hat{I}_{or} = -70$ dBm	0.1 dB for $\frac{E_c}{I_{or}}$ 0.7 dB for \hat{I}_{or}	Formulas: $\frac{E_c}{I_{or}} = \text{ratio} + TT$ $\hat{I}_{or} = \text{Minimum Requirement} + TT$
8.4.4.2 2ms TTI E-DCH E-TFC restriction	$\frac{E_c}{I_{or}}$ -3.5, -10, -24.4dB $\hat{I}_{or} = -70$ dBm	0.1 dB for $\frac{E_c}{I_{or}}$ 0.7 dB for \hat{I}_{or}	Formulas: $\frac{E_c}{I_{or}} = \text{ratio} + TT$ $\hat{I}_{or} = \text{Minimum Requirement} + TT$
8.5 Timing and Signalling Characteristics			

Test	Test Parameters in TS 25.133 [2]	Test Tolerance (TT)	Test Requirement in TS 34.121
8.5.1 UE Transmit Timing	DPCH_Ec/Ior = -13.5 dB CPICH_Ec/Ior = -10 dB Ior1=-96 dB Ior2=-99 dB Rx-Tx Timing accuracy ±1.5 chips ¼ chip / 200ms maximum rate 233ns / s minimum rate	0.1 dB for CPICH_Ec/Ior 0.1 dB for DPCH_Ec/Ior 0.1 dB for DPCH_Ec/Ior 1 dB for Ior1 1.3 dB for Ior2 0.5 chips for Rx-Tx timing accuracy 0.25 chips for Tx-Tx Timing Accuracy	Since the test is performed close to sensitivity level any TT applied to the nominal setting shall fulfil: Ior1 shall not go below -96 dBm Ior2 shall not go below -99 dBm Ior1/Ior2 shall not go above 3 dB DPCH_Ec/Ior shall not go below -13.5 dB CPICH_Ec/Ior shall not go below -10 dB Formulas for test parameters DPCH_Ec/Ior + TT CPICH_Ec/Ior + TT Ior1 + TT Ior2 + TT Rx-Tx Timing accuracy ±2.0 chip Formulas for test requirements: Upper limit +TT Lower limit -TT Tx-Tx Timing accuracies Formulas for test requirements: Upper limit +TT Lower limit -TT
8.6 UE Measurements Procedures			
8.6.1 FDD intra frequency measurements			
8.6.1.1 Event triggered reporting in AWGN propagation conditions (R99)	Because the relationships between the Test system uncertainties and the Test Tolerances are complex, it is not possible to give a simple derivation of the Test Requirement in this document. The analysis is recorded in 3GPP TR 34 902 [24].		
	<u>During T1 to T4:</u> Cell 1: CPICH_Ec/Ior = -10 dB PCCPCH_Ec/Ior = -12 dB SCH_Ec/Ior = -12 dB PICH_Ec/Ior = -15 dB	<u>During T1 to T4:</u> +0.70 dB +0.70 dB +0.70 dB +0.70 dB	<u>During T1 to T4:</u> Ec/Ior ratio + TT Ec/Ior ratio + TT Ec/Ior ratio + TT Ec/Ior ratio + TT
	<u>During T1/T4 only:</u> Already covered above	<u>During T1/T4 only:</u> Covered above	<u>During T1/T4 only:</u> Already covered above
	<u>During T2/T3 only:</u> Cell 2: CPICH_Ec/Ior = -10 dB PCCPCH_Ec/Ior = -12 dB SCH_Ec/Ior = -12 dB PICH_Ec/Ior = -15 dB	<u>During T2/T3 only:</u> +0.70 dB +0.70 dB +0.70 dB +0.70 dB	<u>During T2/T3 only:</u> Ec/Ior ratio + TT Ec/Ior ratio + TT Ec/Ior ratio + TT Ec/Ior ratio + TT
8.6.1.1A Event triggered reporting in AWGN propagation conditions (Rel-4 and later)	Because the relationships between the Test system uncertainties and the Test Tolerances are complex, it is not possible to give a simple derivation of the Test Requirement in this document. The analysis is recorded in 3GPP TR 34 902 [24].		
	<u>During T1 / T2 / T3:</u> Cell 1: CPICH_Ec/Ior = -10 dB PCCPCH_Ec/Ior = -12 dB SCH_Ec/Ior = -12 dB PICH_Ec/Ior = -15 dB	<u>During T1 / T2 / T3:</u> +0.70 dB +0.70 dB +0.70 dB +0.70 dB	<u>During T1 / T2 / T3:</u> Ec/Ior ratio + TT Ec/Ior ratio + TT Ec/Ior ratio + TT Ec/Ior ratio + TT

Test	Test Parameters in TS 25.133 [2]	Test Tolerance (TT)	Test Requirement in TS 34.121
	<p><u>During T1/T3 only :</u></p> <p>Already covered above</p>	<p><u>During T1/T3 only:</u></p> <p>Covered above</p>	<p><u>During T1/T3 only:</u></p> <p>Already covered above</p>
	<p><u>During T2 only:</u></p> <p>Cell 2: CPICH_Ec/lor = -10 dB PCCPCH_Ec/lor = -12 dB SCH_Ec/lor = -12 dB PICH_Ec/lor = -15 dB</p>	<p><u>During T2 only:</u></p> <p>+0.70 dB +0.70 dB +0.70 dB +0.70 dB</p>	<p><u>During T2 only:</u></p> <p>Ec/lor ratio + TT Ec/lor ratio + TT Ec/lor ratio + TT Ec/lor ratio + TT</p>
8.6.1.2 Event triggered reporting of multiple neighbours in AWGN propagation condition (R99)	<p>Because the relationships between the Test system uncertainties and the Test Tolerances are complex, it is not possible to give a simple derivation of the Test Requirement in this document. The analysis is recorded in 3GPP TR 34 902 [24].</p>		
	<p><u>During T0 to T6:</u></p> <p>Cell 1, Cell 2 and Cell 3: CPICH_Ec/lor = -10 dB PCCPCH_Ec/lor = -12 dB SCH_Ec/lor = -12 dB PICH_Ec/lor = -15 dB</p>	<p><u>During T0 to T6:</u></p> <p>+0.70 dB +0.70 dB +0.70 dB +0.70 dB</p>	<p><u>During T0 to T6:</u></p> <p>Ec/lor ratio + TT Ec/lor ratio + TT Ec/lor ratio + TT Ec/lor ratio + TT</p>
8.6.1.2A Event triggered reporting of multiple neighbours in AWGN propagation condition (Rel-4 and later)	<p>Because the relationships between the Test system uncertainties and the Test Tolerances are complex, it is not possible to give a simple derivation of the Test Requirement in this document. The analysis is recorded in 3GPP TR 34 902 [24].</p>		
	<p><u>During T0 to T4:</u></p> <p>Cell 1, Cell 2 and Cell 3: CPICH_Ec/lor = -10 dB PCCPCH_Ec/lor = -12 dB SCH_Ec/lor = -12 dB PICH_Ec/lor = -15 dB</p>	<p><u>During T0 to T4:</u></p> <p>+0.70 dB +0.70 dB +0.70 dB +0.70 dB</p>	<p><u>During T0 to T4:</u></p> <p>Ec/lor ratio + TT Ec/lor ratio + TT Ec/lor ratio + TT Ec/lor ratio + TT</p>
8.6.1.3 Event triggered reporting of two detectable neighbours in AWGN propagation condition (R99)	<p>Because the relationships between the Test system uncertainties and the Test Tolerances are complex, it is not possible to give a simple derivation of the Test Requirement in this document. The analysis is recorded in 3GPP TR 34 902 [24].TBD</p>		
	<p><u>During T0 to T5:</u></p> <p>Cell 1, Cell 2 and Cell 3: CPICH_Ec/lor = -10 dB PCCPCH_Ec/lor = -12 dB SCH_Ec/lor = -12 dB PICH_Ec/lor = -15 dB</p> <p>Cell 1: DPCH_Ec/lor = -17 dB</p>	<p><u>During T0 to T5:</u></p> <p>+0.40 dB +0.40 dB +0.40 dB +0.40 dB</p> <p>+0.40 dB</p>	<p><u>During T0 to T5:</u></p> <p>Ec/lor ratio + TT Ec/lor ratio + TT Ec/lor ratio + TT Ec/lor ratio + TT</p> <p>Ec/lor ratio + TT</p>
8.6.1.3A Event triggered reporting of two detectable neighbours in AWGN propagation condition (Rel-4 and later)	<p>Because the relationships between the Test system uncertainties and the Test Tolerances are complex, it is not possible to give a simple derivation of the Test Requirement in this document. The analysis is recorded in 3GPP TR 34 902 [24].</p>		
	<p><u>During T0 to T4:</u></p> <p>Cell 1, Cell 2 and Cell 3: CPICH_Ec/lor = -10 dB PCCPCH_Ec/lor = -12 dB SCH_Ec/lor = -12 dB PICH_Ec/lor = -15 dB</p> <p>Cell 1: DPCH_Ec/lor = -17 dB</p>	<p><u>During T0 to T4:</u></p> <p>+0.40 dB +0.40 dB +0.40 dB +0.40 dB</p> <p>+0.40 dB</p>	<p><u>During T0 to T4:</u></p> <p>Ec/lor ratio + TT Ec/lor ratio + TT Ec/lor ratio + TT Ec/lor ratio + TT</p> <p>Ec/lor ratio + TT</p>
8.6.1.4A Correct reporting of neighbours in fading propagation	<p>Because the relationships between the Test system uncertainties and the Test Tolerances are complex, it is not possible to give a simple derivation of the Test Requirement in this document. The analysis is recorded in 3GPP TR 34 902 [24].</p>		

Test	Test Parameters in TS 25.133 [2]	Test Tolerance (TT)	Test Requirement in TS 34.121
condition (Rel-4 and later)	During T1 only: Cell 1: CPICH_Ec/lor = -10dB PCCPCH_Ec/lor = -12 dB SCH_Ec/lor = -12 dB PICH_Ec/lor = -15 dB DPCH_Ec/lor = -17 dB Cell 2: CPICH_Ec/lor = -10dB PCCPCH_Ec/lor = -12 dB SCH_Ec/lor = -12 dB PICH_Ec/lor = -15 dB	During T1: +0.70 dB +0.70 dB +0.70 dB +0.70 dB +0.70 dB +0.30 dB +0.30 dB +0.30 dB +0.30 dB	During T1: Ec/lor ratio + TT Ec/lor ratio + TT Ec/lor ratio + TT Ec/lor ratio + TT Ec/lor ratio + TT Ec/lor ratio + TT Ec/lor ratio + TT Ec/lor ratio + TT Ec/lor ratio + TT
	During T2 only: Cell 1: CPICH_Ec/lor = -10dB PCCPCH_Ec/lor = -12 dB SCH_Ec/lor = -12 dB PICH_Ec/lor = -15 dB DPCH_Ec/lor = -17 dB Cell 2: CPICH_Ec/lor = -10dB PCCPCH_Ec/lor = -12 dB SCH_Ec/lor = -12 dB PICH_Ec/lor = -15 dB	During T2: +0.30 dB +0.30 dB +0.30 dB +0.30 dB +0.30 dB +0.70 dB +0.70 dB +0.70 dB +0.70 dB	During T2: Ec/lor ratio + TT Ec/lor ratio + TT Ec/lor ratio + TT Ec/lor ratio + TT Ec/lor ratio + TT Ec/lor ratio + TT Ec/lor ratio + TT Ec/lor ratio + TT Ec/lor ratio + TT
8.6.1.5 Event triggered reporting of multiple neighbour cells in Case 1 fading condition	Because the relationships between the Test system uncertainties and the Test Tolerances are complex, it is not possible to give a simple derivation of the Test Requirement in this document. The analysis is recorded in 3GPP TR 34 902 [24].		
	<u>During T1 and T2:</u> Cell 1, 2, 3 and Cell 4: CPICH_Ec/lor = -10 dB PCCPCH_Ec/lor = -12 dB SCH_Ec/lor = -12 dB PICH_Ec/lor = -15 dB	<u>During T1 and T2:</u> +0.70 dB +0.70 dB +0.70 dB +0.70 dB	<u>During T1 and T2:</u> Ec/lor ratio + TT Ec/lor ratio + TT Ec/lor ratio + TT Ec/lor ratio + TT
8.6.1.6 Event triggered reporting of multiple neighbour cells in Case 3 fading conditions	Because the relationships between the Test system uncertainties and the Test Tolerances are complex, it is not possible to give a simple derivation of the Test Requirement in this document. The analysis is recorded in 3GPP TR 34 902 [24].		
	<u>During T1 and T2:</u> Cell 1, 2, 3 and Cell 4: CPICH_Ec/lor = -10 dB PCCPCH_Ec/lor = -12 dB SCH_Ec/lor = -12 dB PICH_Ec/lor = -15 dB	<u>During T1 and T2:</u> +0.70 dB +0.70 dB +0.70 dB +0.70 dB	<u>During T1 and T2:</u> Ec/lor ratio + TT Ec/lor ratio + TT Ec/lor ratio + TT Ec/lor ratio + TT
8.6.2 FDD inter frequency measurements	TBD		
8.6.2.1 Correct reporting of neighbours in AWGN propagation condition (Release 5 and earlier)	Because the relationships between the Test system uncertainties and the Test Tolerances are complex, it is not possible to give a simple derivation of the Test Requirement in this document. The analysis is recorded in 3GPP TR 34 902 [24].		
	<u>During T0 to T2:</u> Cell 1, Cell 2 and Cell 3: CPICH_Ec/lor = -10 dB PCCPCH_Ec/lor = -12 dB SCH_Ec/lor = -12 dB PICH_Ec/lor = -15 dB Cell 1: DPCH_Ec/lor = -17 dB	<u>During T0 to T2:</u> +0.80 dB +0.80 dB +0.80 dB +0.80 dB +0.80 dB	<u>During T0 to T2:</u> Ec/lor ratio + TT Ec/lor ratio + TT Ec/lor ratio + TT Ec/lor ratio + TT Ec/lor ratio + TT

Test	Test Parameters in TS 25.133 [2]	Test Tolerance (TT)	Test Requirement in TS 34.121
8.6.2.1A Correct reporting of neighbours in AWGN propagation condition (Release 6 and later)	Because the relationships between the Test system uncertainties and the Test Tolerances are complex, it is not possible to give a simple derivation of the Test Requirement in this document. The analysis is recorded in 3GPP TR 34 902 [24].		
	<u>During T0 to T2:</u> Cell 1, Cell 2 and Cell 3: CPICH_Ec/Ior = -10 dB PCCPCH_Ec/Ior = -12 dB SCH_Ec/Ior = -12 dB PICH_Ec/Ior = -15 dB Cell 1: DPCH_Ec/Ior = -17 dB	<u>During T0 to T2:</u> +0.80 dB +0.80 dB +0.80 dB +0.80 dB +0.80 dB	<u>During T0 to T2:</u> Ec/Ior ratio + TT Ec/Ior ratio + TT Ec/Ior ratio + TT Ec/Ior ratio + TT Ec/Ior ratio + TT
8.6.2.2 Correct reporting of neighbours in Fading propagation condition (Release 5 only)	Because the relationships between the Test system uncertainties and the Test Tolerances are complex, it is not possible to give a simple derivation of the Test Requirement in this document. The analysis is recorded in 3GPP TR 34 902 [24].		
	<u>During T1 and T2:</u> Cell 1 and Cell 2: CPICH_Ec/Ior = -10 dB PCCPCH_Ec/Ior = -12 dB SCH_Ec/Ior = -12 dB PICH_Ec/Ior = -15 dB	<u>During T1 and T2:</u> +0.80 dB +0.80 dB +0.80 dB +0.80 dB	<u>During T1 and T2:</u> Ec/Ior ratio + TT Ec/Ior ratio + TT Ec/Ior ratio + TT Ec/Ior ratio + TT
8.6.2.2A Correct reporting of neighbours in Fading propagation condition (Release 6 and later)	Because the relationships between the Test system uncertainties and the Test Tolerances are complex, it is not possible to give a simple derivation of the Test Requirement in this document. The analysis is recorded in 3GPP TR 34 902 [24].		
	<u>During T1 and T2:</u> Cell 1 and Cell 2: CPICH_Ec/Ior = -10 dB PCCPCH_Ec/Ior = -12 dB SCH_Ec/Ior = -12 dB PICH_Ec/Ior = -15 dB	<u>During T1 and T2:</u> +0.80 dB +0.80 dB +0.80 dB +0.80 dB	<u>During T1 and T2:</u> Ec/Ior ratio + TT Ec/Ior ratio + TT Ec/Ior ratio + TT Ec/Ior ratio + TT
8.6.2.3 Correct reporting of neighbours in Fading propagation condition using TGL1=14	Because the relationships between the Test system uncertainties and the Test Tolerances are complex, it is not possible to give a simple derivation of the Test Requirement in this document.		
	<u>During T1 and T2:</u> Cell 1 and Cell 2: CPICH_Ec/Ior = -10 dB PCCPCH_Ec/Ior = -12 dB SCH_Ec/Ior = -12 dB PICH_Ec/Ior = -15 dB	<u>During T1 and T2:</u> +0.80 dB +0.80 dB +0.80 dB +0.80 dB	<u>During T1 and T2:</u> Ec/Ior ratio + TT Ec/Ior ratio + TT Ec/Ior ratio + TT Ec/Ior ratio + TT
8.6.3 TDD measurements	TBD		
8.6.3.1 Correct reporting of TDD neighbours in AWGN propagation condition	TBD		
8.6.4 GSM measurements			

Test	Test Parameters in TS 25.133 [2]	Test Tolerance (TT)	Test Requirement in TS 34.121
8.6.4.1 Correct reporting of GSM neighbours in AWGN propagation condition	<p>During T2 RXLEV=-75 dBm</p> <p>During T3 RXLEV=-85 dBm</p>	<p>During T2: + 1 dB for RXLEV</p> <p>During T3: -1 dB for RXLEV</p>	<p>During T2 and T3 RXLEV + TT</p> <p>Only RXLEV is a critical parameter. UE measurement accuracy for GSM Carrier RSSI is ± 4 dB in this test.</p> <p>During T2: measured GSM Carrier RSSI \pm uncertainty of RXLEV setting shall be above - 80 dBm (Threshold for GSM). => TT=+1 dB for RXLEV</p> <p>During T3: measured GSM Carrier RSSI \pm uncertainty of RXLEV setting shall be below - 80 dBm (Threshold for GSM). => TT=-1 dB for RXLEV</p>
8.6.5 Combined Inter frequency and GSM measurements			
8.6.5.1 Correct reporting of neighbours in AWGN propagation condition	<p><u>During T0 to T5:</u></p> <p>Cell 1 and Cell 2: CPICH_Ec/Ior = -10 dB PCCPCH_Ec/Ior = -12 dB SCH_Ec/Ior = -12 dB PICH_Ec/Ior = -15 dB</p> <p>During T4 to T5: RXLEV=-75 dBm</p>	<p><u>During T0 to T5:</u></p> <p>+0.80 dB +0.80 dB +0.80 dB +0.80 dB</p> <p><u>During T4 and T5:</u> + 1 dB for RXLEV</p>	<p><u>During T0 to T5:</u></p> <p>Ec/Ior ratio + TT Ec/Ior ratio + TT Ec/Ior ratio + TT Ec/Ior ratio + TT</p> <p>During T4 and T5 RXLEV + TT</p>
8.7 Measurements Performance Requirements			
8.7.1 CPICH RSCP			
8.7.1.1 Intra frequency measurements accuracy	see table 8.7.1.1.1 and table 8.7.1.1.2	± 1 dB for loc ± 0.3 dB for Ior/loc ± 0.1 dB for....._Ec/Ior	<p>Any TT applied to the nominal setting shall fulfil: Test 1 (absolute and relative): Ior shall not go below -69dBm Test 2(absolute and relative): Ior shall not go above -50 dBm Test 3 (absolute and relative): Ior shall not go below -94 dBm Ior/loc + TTTT on top of UE measurement accuracy: Absolute± 1.0 dB for loc± 0.3 dB for Ior/loc ± 0.1 dB for CPICH_Ec/Ior \sum 1.4dB Relative± 0.3 dB for Ior/loc (cell1)± 0.3 dB for Ior/loc (cell2)± 0.1 dB for CPICH_Ec/Ior (cell1)± 0.1 dB for CPICH_Ec/Ior (cell2)\sum 0.8dB</p>
8.7.1.2 Inter frequency measurement accuracy	See table 8.7.1.2.1.1 and table 8.7.1.2.1.2	± 1 dB for loc ± 0.3 dB for loc1/loc2 ± 0.3 dB for Ior/loc ± 0.1 dB for_Ec/Ior	<p>Any TT applied to the nominal setting shall fulfil: Test 1: Ior shall not go above -50 dBm Test 2: Ior shall not go below -94 dBm Ior/loc + TTTT on top of UE measurement accuracy: ± 0.3 dB for loc1/loc2± 0.3 dB for Ior/loc (cell1)± 0.3 dB for Ior/loc (cell2)± 0.1 dB for CPICH_Ec/Ior (cell1)± 0.1 dB for CPICH_Ec/Ior (cell2)\sum 1.1 dB</p>

Test	Test Parameters in TS 25.133 [2]	Test Tolerance (TT)	Test Requirement in TS 34.121
8.7.2 CPICH Ec/Io			

Test	Test Parameters in TS 25.133 [2]	Test Tolerance (TT)	Test Requirement in TS 34.121
8.7.2.1 Intra frequency measurements accuracy	table 8.7.2.1.1.1 and table 8.7.2.1.1.2	<p>± 1 dB for Ioc</p> <p>± 0.3 dB for Ior/Ioc</p> <p>± 0.1dB for_Ec/or</p>	<p>Any TT applied to the nominal setting shall fulfil:</p> <p>Test 1 (absolute and relative): Io shall not go above -50 dBm</p> <p>Test 2 (absolute and relative): Io shall not go below -87dBm</p> <p>Test 3 (absolute and relative): Io shall not go below -94 dBm</p> <p>CPICH Ec/Io shall stay in the UE accuracy ranges</p> <p>Ior/Ioc + TT</p> <p>TT on top of UE measurement accuracy:</p> <p>Absolute</p> <p style="padding-left: 40px;">± 0.3 dB for Ior/Ioc</p> <p style="padding-left: 40px;">± 0.1dB for CPICH_Ec/Ior</p> <p style="padding-left: 40px;">Σ 0.4dB</p> <p>Relative</p> <p style="padding-left: 40px;">Ioc1=Ioc2</p> <p style="padding-left: 40px;">± 0.3 dB for Ior/Ioc (cell1)</p> <p style="padding-left: 40px;">± 0.3 dB for Ior/Ioc (cell2)</p> <p style="padding-left: 40px;">± 0.1dB for CPICH_Ec/Ior (cell1)</p> <p style="padding-left: 40px;">± 0.1dB for CPICH_Ec/Ior (cell2)</p> <p style="padding-left: 40px;">Σ 0.8dB</p>

Test	Test Parameters in TS 25.133 [2]	Test Tolerance (TT)	Test Requirement in TS 34.121
8.7.2.2 Inter frequency measurement accuracy	table 8.7.2.2.2.1 and table 8.7.2.2.2.2	±1 dB for Ioc ±0.3 dB for Ioc1/Ioc2 ±0.3 dB for Ior/Ioc ±0.1dB forEc/Ior	Any TT applied to the nominal setting shall fulfil: Test 1: Io shall not go above -50 dBm Test 2: Io shall not go below -87 dBm Test 3: Io shall not go below -94 dBm Ior/Ioc + TT TT on top of UE measurement accuracy: Ioc1=Ioc2. ±0.3 dB for Ior/Ioc (cell1) ±0.3 dB for Ior/Ioc (cell2) ±0.1dB for CPICH_Ec/Ior (cell1) ±0.1dB for CPICH_Ec/Ior (cell2) ∑ 0.8 dB

Test	Test Parameters in TS 25.133 [2]	Test Tolerance (TT)	Test Requirement in TS 34.121
8.7.3.1 UTRA Carrier RSSI, absolute measurement accuracy	Table 8.7.3.1.2	<p>± 1 dB for I_{oc}</p> <p>± 0.3 dB for I_{oc1}/I_{oc2}</p> <p>± 0.3 dB for \hat{I}_{or}/I_{oc}</p>	<p>Any TT applied to the nominal setting shall fulfil:</p> <p>Test 1: I_o shall not go above -50 dBm</p> <p>Test 2: I_o shall not go below -69 dBm</p> <p>Test 3: I_o shall not go below -94 dBm</p> <p>$I_{or}/I_{oc} + TT$</p> <p>TT on top of UE measurement accuracy:</p> <p>Test 1:</p> <p style="padding-left: 20px;">Max TT= $I_{o_{max}} - I_{o_{nominal}}$</p> <p style="padding-left: 20px;">$I_{o_{nominal}} = -51.15$ dBm</p> <p style="padding-left: 20px;">$I_{o_{max}} = I_{oc_{max}} + I_{or_{max}} = (-53.5$ dBm + 1dB) + (-52.5 dBm - 1.45 dB + 0.3 dB) = -50.0 dBm</p> <p style="padding-left: 20px;">=> Max TT = 1.15 dB</p> <p style="padding-left: 20px;">Min TT = $I_{o_{min}} - I_o$</p> <p style="padding-left: 20px;">$I_{o_{min}} = I_{oc_{min}} + I_{or_{min}} = (-53.5$ dBm - 1 dB) + (-54.5 dBm - 1.45 dB - 0.3 dB) = - 52.3 dBm</p> <p style="padding-left: 20px;">=> Min TT = -1.15 dB</p> <p>Test 2:</p> <p style="padding-left: 20px;">Max TT= $I_{o_{max}} - I_{o_{nominal}}$</p> <p style="padding-left: 20px;">$I_{o_{nominal}} = - 67.9$ dBm</p> <p style="padding-left: 20px;">$I_{o_{max}} = I_{oc_{max}} + I_{or_{max}} = (-69.27$ dBm + 1dB) + (-68.27 dBm - 4.4 dB + 0.3 dB) = -66.8 dBm</p> <p style="padding-left: 20px;">=> Max TT = 1.1 dB</p> <p style="padding-left: 20px;">Min TT = $I_{o_{min}} - I_o$</p> <p style="padding-left: 20px;">$I_{o_{min}} = I_{oc_{min}} + I_{or_{min}} = (-69.27$ dBm - 1 dB) + (-70.27 dBm - 4.4 dB - 0.3 dB) = -69.0 dBm</p> <p style="padding-left: 20px;">=> Min TT = -1.1 dB</p> <p>Test 3 (Band I):</p> <p style="padding-left: 20px;">Max TT= $I_{o_{max}} - I_{o_{nominal}}$</p> <p style="padding-left: 20px;">$I_{o_{nominal}} = -93$ dBm</p> <p style="padding-left: 20px;">$I_{o_{max}} = I_{oc_{max}} + I_{or_{max}} + N_o = (-93.46$ dBm + 1dB) + (-92.46 dBm - 9.24 dB + 0.3 dB) + -99 dBm = -91.2</p> <p style="padding-left: 20px;">=> Max TT = 1.8 dB</p>

Test	Test Parameters in TS 25.133 [2]	Test Tolerance (TT)	Test Requirement in TS 34.121
<p>8.7.3.2 UTRA Carrier RSSI, relative measurement accuracy</p>	<p>Table 8.7.3.2.1A</p>	<p>± 1 dB for I_{oc}</p> <p>± 0.3 dB for I_{oc2}/I_{oc3}</p> <p>± 0.3 dB for \hat{I}_{or}/I_{oc}</p>	<p>Any TT applied to the nominal setting shall fulfil:</p> <p>Test 1: I_o shall not go above -50 dBm. $I_{o3}-I_{o2}$ shall not go below -20 dB.</p> <p>Test 2: I_o shall not go below -91 dBm. $I_{o3}-I_{o2}$ shall not go above 20 dB</p> <p>Test 3: I_o shall not go below -94 dBm (Band I). $I_{o3}-I_{o2}$ shall not go above 20 dB.</p> <p>$I_{or}/I_{oc} + TT$</p> <p>TT on top of UE measurement accuracy:</p> <p>Test 1:</p> <ul style="list-style-type: none"> ± 0.3 dB for I_{oc3}/I_{oc2} ratio ± 0.3 dB for I_{or2}/I_{oc2} ratio ± 0.3 dB for I_{or3}/I_{oc3} ratio <p>$\sum \pm 0.9$ dB (This is the worst case since G factor makes the actual tolerance lower.</p> <p>No impact from Noise Floor.</p> <p>The same TT for all bands.</p> <p>Test 2:</p> <ul style="list-style-type: none"> ± 0.3 dB for I_{oc3}/I_{oc2} ratio ± 0.3 dB for I_{or2}/I_{oc2} ratio ± 0.3 dB for I_{or3}/I_{oc3} ratio <p>$\sum \pm 0.9$ dB (This is the worst case since G factor makes the actual tolerance lower).</p> <p>Noise floor impact:</p> <p>Noise floor = -96 dB for Band III and VIII (worst case). => I_{o2} increases by 1.0 dB, I_{o3} increases by 0.1 dB. Thus noise floor increases the test tolerance by 0.9 dB</p> <p>=> TT = ± 1.8 dB</p> <p>The same TT for all bands.</p> <p>Test 3:</p> <ul style="list-style-type: none"> ± 0.3 dB for I_{oc3}/I_{oc2} ratio ± 0.3 dB for I_{or2}/I_{oc2} ratio ± 0.3 dB for I_{or3}/I_{oc3} ratio <p>$\sum \pm 0.9$ dB (This is the worst case since G factor makes</p>

Test	Test Parameters in TS 25.133 [2]	Test Tolerance (TT)	Test Requirement in TS 34.121
8.7.3A GSM Carrier RSSI	WCDMA cell parameters: See table 8.7.3A.2 GSM cell parameters: See table 8.7.3A.3	<p>TT for test parameters</p> <p>GSM cell levels: Step 1: -1 dB Step 2: -1 dB Step 3: -1 dB Step 4: +1 dB</p> <p>TT for test requirements:</p> <p>Relative accuracy requirements: a, b, c and d values in minimum requirements are increased by 2 dB i.e.,</p> <p>For $x_1 \geq s+14$, $x_2 < -48$ dBm: a=4, b=4, c=6, d=6</p> <p>For $s+14 > x_1 \geq s+1$ a=5, b=4, c=7, d=6</p> <p>For $s+1 > x_1$ a=6, b=4, c=8, d=6</p> <p>Absolute accuracy requirements: original minimum requirements are increased by ± 1 dB</p>	<p>WCDMA: Test parameter settings are unchanged since level settings in either direction are not critical with respect to the outcome of the test</p> <p>GSM: Test parameter settings are changed in steps 1,2,3 and 4 as follows: BCCH levels are increased by test tolerance so that during Step 1, level ≤ 38 dBm, Step 2, level ≤ 48 dBm, Step 3, level ≤ 70 dBm, Step 4, level ≥ -110 dBm. Hence during steps 1,2,3 and 4: New levels=Original levels + TT</p> <p>For other steps 5 to 12 GSM test parameter settings are unchanged since level settings in either direction are not critical with respect to the outcome of the test</p> <p>TT on top of UE measurement accuracy: Relative accuracy: Test system uncertainty ± 1.4 dB. Rounded to ± 2 dB due to granularity of GSM Carrier RSSI report mapping of 1 dB. Absolute accuracy: Test system uncertainty ± 1.0 dB. No need to increase due to granularity of GSM Carrier RSSI report mapping of 1 dB.</p>
8.7.3B Transport channel BLER	TBD		
8.7.3C UE Transmitted power (R99 and Rel-4 only)	Accuracy upper limit Accuracy lower limit Depends on PUEMAX see table 8.7.3C.2.1	0.7 dB	<p>Formula: Upper accuracy limit + TT Lower accuracy limit - TT Add and subtract TT to all the values in table 8.7.3C.2.1.</p>
8.7.3D UE Transmitted power (Rel-5 and later)	Accuracy upper limit Accuracy lower limit	0.7 dB	<p>Formula: Upper accuracy limit + TT Lower accuracy limit - TT Add and subtract TT to all the accuracy values in table 8.7.3D.4.3.</p>

Test	Test Parameters in TS 25.133 [2]	Test Tolerance (TT)	Test Requirement in TS 34.121
8.7.4 SFN-CFN observed time difference	Table 8.7.4.1.2 and Table 8.7.4.2.2	± 1.0 dB for loc ± 0.3 dB for lor/loc ± 0.5 chips for the actual SFN-CFN observed time difference	Intra and inter frequency case: Test 1: lo shall not go above -50 dBm Test 2: No restrictions on lo value Test 3: lo shall not go below -94 dBm (Band 1, IV, VI, X), or below -93 dBm (Band IX), or below -92 dBm (Band II, V, VII, XI) or below -91 dBm (Band III, VIII) $\hat{lor}/loc + TT$ TT on top of UE measurements accuracy: SFN-CFN observed time difference: 1.0 chips + TT
8.7.5.1 SFN-SFN observed time difference type 1	Table 8.7.5.1.2	± 1.0 dB for loc ± 0.3 dB for lor/loc ± 0.5 chips for the actual SFN-SFN observed time difference	Test 1: lo shall not go above -50 dBm Test 2: No restrictions on lo value Test 3: lo shall not go below -94 dBm (Band 1, IV, VI, X), or below -93 dBm (Band IX), or below -92 dBm (Band II, V, VII, XI) or below -91 dBm (Band III, VIII) $\hat{lor}/loc + TT$ TT on top of UE measurements accuracy: SFN-SFN observed time difference: 1.0 chips + TT

Test	Test Parameters in TS 25.133 [2]	Test Tolerance (TT)	Test Requirement in TS 34.121
8.7.6 UE Rx-Tx time difference	$l_o - 10.9 \text{ dB} = l_{oc}$, Test 1: $l_o = -94 \text{ dBm}$ Test2 : $l_o = -72 \text{ dBm}$ Test3 : $l_o = -50 \text{ dBm}$ Timing Accuracy $\pm 1.5 \text{ chip}$	1 dB for l_{oc} 0.3 dB for l_{or}/l_{oc} 0.5 chip for timing accuracy	Test 1: $l_o = -92.7 \text{ dBm}$, $l_{oc} = -103.6 \text{ dBm}$ Formula: $l_{oc} * (1 - TT_{l_{oc}} + (l_{or}/l_{oc} - TT_{l_{or}/l_{oc}})) \geq -94$ Test 2: unchanged (no critical RF parameters) Test 3: $l_o = -51.3 \text{ dBm}$, $l_{oc} = -62.2 \text{ dBm}$ Formula: $l_{oc} * (1 + TT_{l_{oc}} + (l_{or}/l_{oc} + TT_{l_{or}/l_{oc}})) \leq -50$ Timing accuracy $\pm 2.0 \text{ chip}$ Formulas: Upper limit $+TT$ Lower limit $-TT$
8.7.7 Observed time difference to GSM cell	TBD		
8.7.8 P-CCPCH RSCP	TBD		
8.7.9 UE Transmission Power Headroom	UPH reporting accuracy from $\pm 2 \text{ dB}$ to $\pm 6 \text{ dB}$, depending on UE power class and total UE output power.	0.8 dB for UPH reporting accuracy	Formula: (Upper) Minimum Requirement $+ TT$ (Lower) Minimum Requirement $- TT$ UPH reporting accuracy from $\pm 2.8 \text{ dB}$ to $\pm 6.8 \text{ dB}$, depending on UE power class and total UE output power.

F.4.5 Performance requirements (HSDPA)

Table F.4.5: Derivation of Test Requirements (Performance tests HSDPA)

Test	Minimum Requirement in TS 25.101	Test Tolerance (TT)	Test Requirement in TS 34.121
9.2.1A to 9.2.1G Single Link Performance	$\frac{E_c}{I_{or}}$ -12, -9, -6 and -3 dB $I_{oc} = -60$ dBm $\hat{I}_{or}/I_{oc} = 0$ and 10 dB	0.1 dB for $\frac{E_c}{I_{or}}$ 0.6 dB for \hat{I}_{or}/I_{oc}	Formulas: $\frac{E_c}{I_{or}} = \text{ratio} + \text{TT}$ $\hat{I}_{or}/I_{oc} = \text{ratio} + \text{TT}$ I_{oc} unchanged
9.2.2A to 9.2.2D Open loop diversity performance	$\frac{E_c}{I_{or}}$ -6 and -3 dB $I_{oc} = -60$ dBm $\hat{I}_{or}/I_{oc} = 0$ and 10 dB	0.1 dB for $\frac{E_c}{I_{or}}$ 0.8 dB for \hat{I}_{or}/I_{oc}	Formulas: $\frac{E_c}{I_{or}} = \text{ratio} + \text{TT}$ $\hat{I}_{or}/I_{oc} = \text{ratio} + \text{TT}$ I_{oc} unchanged
9.2.3A to 9.2.3D Closed loop diversity performance	Same as 9.2.2A	Same as 9.2.2A	Same as 9.2.2A
9.3.1 Single Link Performance - AWGN propagation conditions		No test tolerances applied	
9.3.2 Single Link Performance - Fading propagation conditions		No test tolerances applied	
9.3.3 Open Loop Diversity Performance - AWGN propagation conditions		No test tolerances applied	
9.3.4 Open Loop Diversity Performance - Fading propagation conditions		No test tolerances applied	
9.3.5 Closed Loop Diversity Performance - AWGN propagation conditions		No test tolerances applied	
9.3.6 Closed Loop Diversity Performance - Fading propagation conditions		No test tolerances applied	
9.4.1 Single Link Performance	$\frac{E_c}{I_{or}}$ -9, -9.9 and -10 dB $I_{oc} = -60$ dBm $\hat{I}_{or}/I_{oc} = 0$ and 5 dB	0.1 dB for $\frac{E_c}{I_{or}}$ 0.6 dB for \hat{I}_{or}/I_{oc}	Formulas: $\frac{E_c}{I_{or}} = \text{ratio} + \text{TT}$ $\hat{I}_{or}/I_{oc} = \text{ratio} + \text{TT}$ I_{oc} unchanged
9.4.1A Single Link Performance - Enhanced Performance Requirements Type 1	$\frac{E_c}{I_{or}}$ -12 and -15.6 dB $I_{oc} = -60$ dBm $\hat{I}_{or}/I_{oc} = 0$ dB	0.1 dB for $\frac{E_c}{I_{or}}$ 0.6 dB for \hat{I}_{or}/I_{oc}	Formulas: $\frac{E_c}{I_{or}} = \text{ratio} + \text{TT}$ $\hat{I}_{or}/I_{oc} = \text{ratio} + \text{TT}$ I_{oc} unchanged

Test	Minimum Requirement in TS 25.101	Test Tolerance (TT)	Test Requirement in TS 34.121
9.4.2 Open loop diversity performance	$\frac{E_c}{I_{or}}$ -11.6, -13.4 and -11.5 dB $I_{oc} = -60$ dBm $\hat{I}_{or}/I_{oc} = 0$ and 5 dB	0.1 dB for $\frac{E_c}{I_{or}}$ 0.8 dB for \hat{I}_{or}/I_{oc}	Formulas: $\frac{E_c}{I_{or}} = \text{ratio} + \text{TT}$ $\hat{I}_{or}/I_{oc} = \text{ratio} + \text{TT}$ I_{oc} unchanged
9.4.2A Open loop diversity performance – Enhanced Performance Requirements Type 1	$\frac{E_c}{I_{or}}$ -15.2 and -16.4 dB $I_{oc} = -60$ dBm $\hat{I}_{or}/I_{oc} = 0$ dB	0.1 dB for $\frac{E_c}{I_{or}}$ 0.8 dB for \hat{I}_{or}/I_{oc}	Formulas: $\frac{E_c}{I_{or}} = \text{ratio} + \text{TT}$ $\hat{I}_{or}/I_{oc} = \text{ratio} + \text{TT}$ I_{oc} unchanged

F.4.6 Performance requirements (E-DCH)

Table F.4.6: Derivation of Test Requirements (Performance tests E-DCH)

Test	Minimum Requirement in TS 25.101	Test Tolerance (TT)	Test Requirement in TS 34.121
10.2.1.1 Detection of E-DCH HARQ ACK Indicator Channel (E-HICH) Single Link Performance (10 ms TTI)	E-HICH_Ec/lor = -35.1 dB $I_{oc} = -60$ dBm $\hat{I}_{or}/I_{oc} = 0$ dB	0.1 dB for E-HICH_Ec/lor 0.6 dB for \hat{I}_{or}/I_{oc}	Formulas: E-HICH_Ec/lor = ratio + TT $\hat{I}_{or}/I_{oc} = \text{ratio} + \text{TT}$ I_{oc} unchanged
10.2.1.1A Detection of E-DCH HARQ ACK Indicator Channel (E-HICH) Single Link Performance (10 ms TTI, Type 1)	E-HICH_Ec/lor = -38.1 dB $I_{oc} = -60$ dBm $\hat{I}_{or}/I_{oc} = 0$ dB	0.1 dB for E-HICH_Ec/lor 0.6 dB for \hat{I}_{or}/I_{oc}	Formulas: E-HICH_Ec/lor = ratio + TT $\hat{I}_{or}/I_{oc} = \text{ratio} + \text{TT}$ I_{oc} unchanged
10.2.1.2 Detection of E-DCH HARQ ACK Indicator Channel (E-HICH) Single Link Performance (2 ms TTI)	E-HICH_Ec/lor = -28.3 dB $I_{oc} = -60$ dBm $\hat{I}_{or}/I_{oc} = 0$ dB	0.1 dB for E-HICH_Ec/lor 0.6 dB for \hat{I}_{or}/I_{oc}	Same as in 10.2.1.1
10.2.1.2A Detection of E-DCH HARQ ACK Indicator Channel (E-HICH) Single Link Performance (2 ms TTI, Type 1)	E-HICH_Ec/lor = -31.7 dB $I_{oc} = -60$ dBm $\hat{I}_{or}/I_{oc} = 0$ dB	0.1 dB for E-HICH_Ec/lor 0.6 dB for \hat{I}_{or}/I_{oc}	Same as in 10.2.1.1
10.2.2.1.1 Detection of E-DCH HARQ ACK Indicator Channel (E-HICH) in Inter-Cell handover conditions – RLS not containing the serving E-DCH cell (10 ms TTI)	E-HICH_Ec/lor = -23.6 dB $I_{oc} = -60$ dBm $\hat{I}_{or1}/I_{oc} = 0$ dB $\hat{I}_{or2}/I_{oc} = 0$ dB	0.1 dB for E-HICH_Ec/lor 0.6 dB for \hat{I}_{or1}/I_{oc} and \hat{I}_{or2}/I_{oc}	Formulas: E-HICH_Ec/lor = ratio + TT $\hat{I}_{or1}/I_{oc} = \text{ratio} + \text{TT}$ $\hat{I}_{or2}/I_{oc} = \text{ratio} + \text{TT}$ I_{oc} unchanged
10.2.2.1.1A Detection of E-DCH HARQ ACK Indicator Channel (E-HICH) in Inter-Cell handover conditions – RLS not containing the serving E-DCH cell (10 ms TTI, Type 1)	E-HICH_Ec/lor = -27.8 dB $I_{oc} = -60$ dBm $\hat{I}_{or1}/I_{oc} = 0$ dB $\hat{I}_{or2}/I_{oc} = 0$ dB	0.1 dB for E-HICH_Ec/lor 0.6 dB for \hat{I}_{or1}/I_{oc} and \hat{I}_{or2}/I_{oc}	Formulas: E-HICH_Ec/lor = ratio + TT $\hat{I}_{or1}/I_{oc} = \text{ratio} + \text{TT}$ $\hat{I}_{or2}/I_{oc} = \text{ratio} + \text{TT}$ I_{oc} unchanged
10.2.2.1.2 Detection of E-DCH HARQ ACK Indicator Channel (E-HICH) in Inter-Cell handover conditions – RLS not containing the serving E-DCH cell (2 ms TTI)	E-HICH_Ec/lor = -16.3 dB $I_{oc} = -60$ dBm $\hat{I}_{or1}/I_{oc} = 0$ dB $\hat{I}_{or2}/I_{oc} = 0$ dB	0.1 dB for E-HICH_Ec/lor 0.6 dB for \hat{I}_{or1}/I_{oc} and \hat{I}_{or2}/I_{oc}	Same as 10.2.2.1.1
10.2.2.1.2A Detection of E-DCH HARQ ACK Indicator Channel (E-HICH) in Inter-Cell handover conditions – RLS not containing the serving E-DCH cell (2 ms TTI, Type 1)	E-HICH_Ec/lor = -20.6 dB $I_{oc} = -60$ dBm $\hat{I}_{or1}/I_{oc} = 0$ dB $\hat{I}_{or2}/I_{oc} = 0$ dB	0.1 dB for E-HICH_Ec/lor 0.6 dB for \hat{I}_{or1}/I_{oc} and \hat{I}_{or2}/I_{oc}	Same as 10.2.2.1.1

Test	Minimum Requirement in TS 25.101	Test Tolerance (TT)	Test Requirement in TS 34.121
10.2.2.2.1 Detection of E-DCH HARQ ACK Indicator Channel (E-HICH) in Inter-Cell handover conditions – RLS containing the serving E-DCH cell (10 ms TTI)	E-HICH_Ec/lor = -29.7 dB $I_{oc} = -60$ dBm $\hat{I}_{or1}/I_{oc} = 0$ dB $\hat{I}_{or2}/I_{oc} = 0$ dB	0.1 dB for E-HICH_Ec/lor 0.6 dB for \hat{I}_{or1}/I_{oc} and \hat{I}_{or2}/I_{oc}	Same as 10.2.2.1.1
10.2.2.2.1A Detection of E-DCH HARQ ACK Indicator Channel (E-HICH) in Inter-Cell handover conditions – RLS containing the serving E-DCH cell (10 ms TTI, Type 1)	E-HICH_Ec/lor = -33.4 dB $I_{oc} = -60$ dBm $\hat{I}_{or1}/I_{oc} = 0$ dB $\hat{I}_{or2}/I_{oc} = 0$ dB	0.1 dB for E-HICH_Ec/lor 0.6 dB for \hat{I}_{or1}/I_{oc} and \hat{I}_{or2}/I_{oc}	Same as 10.2.2.1.1
10.2.2.2.2 Detection of E-DCH HARQ ACK Indicator Channel (E-HICH) in Inter-Cell handover conditions – RLS containing the serving E-DCH cell (2 ms TTI)	E-HICH_Ec/lor = -23.2 dB $I_{oc} = -60$ dBm $\hat{I}_{or1}/I_{oc} = 0$ dB $\hat{I}_{or2}/I_{oc} = 0$ dB	0.1 dB for E-HICH_Ec/lor 0.6 dB for \hat{I}_{or1}/I_{oc} and \hat{I}_{or2}/I_{oc}	Same as 10.2.2.1.1
10.2.2.2.2A Detection of E-DCH HARQ ACK Indicator Channel (E-HICH) in Inter-Cell handover conditions – RLS containing the serving E-DCH cell (2 ms TTI, Type 1)	E-HICH_Ec/lor = -27.1 dB $I_{oc} = -60$ dBm $\hat{I}_{or1}/I_{oc} = 0$ dB $\hat{I}_{or2}/I_{oc} = 0$ dB	0.1 dB for E-HICH_Ec/lor 0.6 dB for \hat{I}_{or1}/I_{oc} and \hat{I}_{or2}/I_{oc}	Same as 10.2.2.1.1
10.3.1.1 Detection of E-DCH Relative Grant Channel (E-RGCH) Single Link Performance (10 ms TTI)	E-RGCH_Ec/lor = -31 dB $I_{oc} = -60$ dBm $\hat{I}_{or}/I_{oc} = 0$ dB	0.1 dB for E-RGCH_Ec/lor 0.6 dB for \hat{I}_{or}/I_{oc}	Formulas: E-RGCH_Ec/lor = ratio + TT $\hat{I}_{or}/I_{oc} = \text{ratio} + \text{TT}$ I_{oc} unchanged
10.3.1.1A Detection of E-DCH Relative Grant Channel (E-RGCH) Single Link Performance (10 ms TTI, Type 1)	E-RGCH_Ec/lor = -35 dB $I_{oc} = -60$ dBm $\hat{I}_{or}/I_{oc} = 0$ dB	0.1 dB for E-RGCH_Ec/lor 0.6 dB for \hat{I}_{or}/I_{oc}	Formulas: E-RGCH_Ec/lor = ratio + TT $\hat{I}_{or}/I_{oc} = \text{ratio} + \text{TT}$ I_{oc} unchanged
10.3.1.2 Detection of E-DCH Relative Grant Channel (E-RGCH) Single Link Performance (2 ms TTI)	E-RGCH_Ec/lor = -24.4 dB $I_{oc} = -60$ dBm $\hat{I}_{or}/I_{oc} = 0$ dB	0.1 dB for for E-RGCH_Ec/lor 0.6 dB for \hat{I}_{or}/I_{oc}	Same as 10.3.1.1
10.3.1.2A Detection of E-DCH Relative Grant Channel (E-RGCH) Single Link Performance (2 ms TTI, Type 1)	E-RGCH_Ec/lor = -28.6 dB $I_{oc} = -60$ dBm $\hat{I}_{or}/I_{oc} = 0$ dB	0.1 dB for for E-RGCH_Ec/lor 0.6 dB for \hat{I}_{or}/I_{oc}	Same as 10.3.1.1
10.3.2 Detection of E-DCH Relative Grant Channel (E-RGCH) in Inter-Cell Handover conditions	E-RGCH_Ec/lor = -27.3 dB $I_{oc} = -60$ dBm $\hat{I}_{or1}/I_{oc} = 0$ dB $\hat{I}_{or2}/I_{oc} = 0$ dB	0.1 dB for E-RGCH_Ec/lor 0.6 dB for \hat{I}_{or1}/I_{oc} and \hat{I}_{or2}/I_{oc}	Formulas: E-RGCH_Ec/lor = ratio + TT $\hat{I}_{or1}/I_{oc} = \text{ratio} + \text{TT}$ $\hat{I}_{or2}/I_{oc} = \text{ratio} + \text{TT}$ I_{oc} unchanged

Test	Minimum Requirement in TS 25.101	Test Tolerance (TT)	Test Requirement in TS 34.121
10.3.2A Detection of E-DCH Relative Grant Channel (E-RGCH) in Inter-Cell Handover conditions (Type 1)	$E\text{-RGCH_Ec/lor} = -31.2 \text{ dB}$ $I_{oc} = -60 \text{ dBm}$ $\hat{I}_{or1}/I_{oc} = 0 \text{ dB}$ $\hat{I}_{or2}/I_{oc} = 0 \text{ dB}$	0.1 dB for E-RGCH_Ec/lor 0.6 dB for \hat{I}_{or1}/I_{oc} and \hat{I}_{or2}/I_{oc}	Formulas: $E\text{-RGCH_Ec/lor} = \text{ratio} + \text{TT}$ $\hat{I}_{or1}/I_{oc} = \text{ratio} + \text{TT}$ $\hat{I}_{or2}/I_{oc} = \text{ratio} + \text{TT}$ I_{oc} unchanged
10.4.1 Demodulation of E-DCH Absolute Grant Channel (E-AGCH) Single Link Performance	$E\text{-AGCH_Ec/lor} = -23.2 \text{ dB}$ $I_{oc} = -60 \text{ dBm}$ $\hat{I}_{or}/I_{oc} = 0 \text{ dB}$	0.1 dB for E-AGCH_Ec/lor 0.6 dB for \hat{I}_{or}/I_{oc}	Formulas: $E\text{-AGCH_Ec/lor} = \text{ratio} + \text{TT}$ $\hat{I}_{or}/I_{oc} = \text{ratio} + \text{TT}$ I_{oc} unchanged
10.4.1A Demodulation of E-DCH Absolute Grant Channel (E-AGCH) Single Link Performance (Type 1)	$E\text{-AGCH_Ec/lor} = -26.8 \text{ dB}$ $I_{oc} = -60 \text{ dBm}$ $\hat{I}_{or}/I_{oc} = 0 \text{ dB}$	0.1 dB for E-AGCH_Ec/lor 0.6 dB for \hat{I}_{or}/I_{oc}	Formulas: $E\text{-AGCH_Ec/lor} = \text{ratio} + \text{TT}$ $\hat{I}_{or}/I_{oc} = \text{ratio} + \text{TT}$ I_{oc} unchanged

F.4.7 Performance requirements (MBMS)

Table F.4.7: Derivation of Test Requirements (Performance tests MBMS)

Test	Minimum Requirement in TS 25.101	Test Tolerance (TT)	Test Requirement in TS 34.121
11.3 Demodulation of MTCH and cell identification	$S\text{-CCPCH_Ec/lor} = -5.6 \text{ dB}$ Stage 1: $I_{oc} = -70 \text{ dB}$ $\hat{I}_{or1}/I_{oc} = -3 \text{ dB}$ $\hat{I}_{or2}/I_{oc} = -3 \text{ dB}$ $\hat{I}_{or3}/I_{oc} = \text{-infinity}$ Stage 2: $I_{oc} = -73 \text{ dB}$ $\hat{I}_{or1}/I_{oc} = 0 \text{ dB}$ $\hat{I}_{or2}/I_{oc} = 0 \text{ dB}$ $\hat{I}_{or3}/I_{oc} = 0 \text{ dB}$ Stage 3: $I_{oc} = -70 \text{ dB}$ $\hat{I}_{or1}/I_{oc} = -3 \text{ dB}$ $\hat{I}_{or2}/I_{oc} = \text{-infinity}$ $\hat{I}_{or3}/I_{oc} = -3 \text{ dB}$	0.1 dB for S-CCPCH_Ec/lor ratio 0.6 dB for \hat{I}_{or1}/I_{oc} 0.6 dB for \hat{I}_{or2}/I_{oc} 0.6 dB for \hat{I}_{or3}/I_{oc}	Formulas: $S\text{-CCPCH_Ec/lor} = \text{ratio} + \text{TT}$ I_{oc} unchanged $\hat{I}_{or1}/I_{oc} = \text{ratio} + \text{TT}$ $\hat{I}_{or2}/I_{oc} = \text{ratio} + \text{TT}$ $\hat{I}_{or3}/I_{oc} = \text{ratio} + \text{TT}$

F.5 Acceptable uncertainty of Test Equipment (This clause is informative)

This informative clause specifies the critical parameters of the components of an overall Test System (e.g. Signal generators, Signal Analysers etc.) which are necessary when assembling a Test System that complies with clause F.1 Acceptable Uncertainty of Test System. These Test Equipment parameters are fundamental to the accuracy of the overall Test System and are unlikely to be improved upon through System Calibration.

F.5.1 Transmitter measurements

Table F.5.1: Equipment accuracy for transmitter measurements

Test	Equipment accuracy	Test conditions
5.2 Maximum Output Power	Not critical	19 to 25 dBm
5.2A Maximum Output Power with HS-DPCCH (Release 5 only)	Not critical	19 to 25 dBm
5.2AA Maximum Output Power with HS-DPCCH (Release 6 and later)	Not critical	19 to 25 dBm
5.2B Maximum Output Power with HS-DPCCH and E-DCH	Not critical	19 to 25 dBm
5.2C UE relative code domain power accuracy	For 0 dB ≥ -10 dB CDP ± 0.2 dB For -10 dB ≥ -15 dB CDP ± 0.3 dB For -15 dB ≥ -20 dB CDP ± 0.4 dB	-10 to 10 dBm
5.2D UE Relative Code Domain Power Accuracy with HS-DPCCH and E-DCH	For 0 dB ≥ -10 dB CDP ± 0.2] dB For -10 dB ≥ -15 dB CDP ± 0.3] dB For -15 dB ≥ -20 dB CDP ± 0.4] dB	-10 to 10 dBm
5.3 Frequency error	± 10 Hz	0 to 500 Hz.
5.4.1 Open loop power control in uplink	Not critical	-43.7 dBm to 25 dBm
5.4.2 Inner loop power control in the uplink	±0.1 dB relative over a 1.5 dB range ±0.15 dB relative over a 3.0 dB range ±0.2 dB relative over a 4.5 dB range ±0.3 dB relative over a 26 dB range	+25 dBm to -50 dBm
5.4.3 Minimum Output Power	Not critical	
5.4.4 Out-of-synchronisation handling of output power: $\frac{DPCCCH_E_c}{I_{or}}$	±0.1 dB uncertainty in DPCCCH_Ec/Ior ratio	Ratio from -16.6 dB to -28 dB
5.5.1 Transmit ON/OFF Power: UE transmit OFF power	Not critical	-56 dBm (static power)
5.5.2 Transmit ON/OFF Power: transmit ON/OFF time mask	TBD	-56 dBm (dynamic power over approx. 70 dB range)
5.6 Change of TFC: power control step size	±0.3 dB relative over a 9 dB range	+25 dBm to -50 dBm
5.7 Power setting in uplink compressed mode:-UE output power	Subset of 5.4.2	+25 dBm to -50 dBm
5.7A HS-DPCCH	±0.1 dB relative over a 1.5 dB range ±0.15 dB relative over a 3.0 dB range ±0.2 dB relative over a 4.5 dB range ±0.3 dB relative over a 26 dB range	+25 dBm to -50 dBm
5.8 Occupied Bandwidth	±100 kHz	For results between 4 and 6 MHz?
5.9 Spectrum emission mask	Not critical	P_Max Accuracy applies ± 5 dB either side of UE requirements
5.9A Spectrum emission mask with HS-DPCCH	Not critical	P_Max Accuracy applies ± 5 dB either side of UE requirements
5.9B Spectrum emission mask with E-DCH	Not critical	P_Max Accuracy applies ± 5 dB either side of UE requirements
5.10 ACLR	5 MHz offset ± 0.8 dB 10 MHz offset ± 0.8 dB	19 to 25 dBm at 5 MHz offset for results between 40 dB and 50 dB. 25 dBm at 10 MHz offset for results between 45 dB and 55 dB.

5.10A ACLR with HS-DPCCH	5 MHz offset ± 0.8 dB 10 MHz offset ± 0.8 dB	19 to 25 dBm at 5 MHz offset for results between 40 dB and 50 dB. 25 dBm at 10 MHz offset for results between 45 dB and 55 dB.
5.10B ACLR with E-DCH	5 MHz offset ± 0.8 dB 10 MHz offset ± 0.8 dB	19 to 25 dBm at 5 MHz offset for results between 40 dB and 50 dB. 25 dBm at 10 MHz offset for results between 45 dB and 55 dB.
5.11 Spurious emissions	Not critical	19 to 25 dBm
5.12 Transmit Intermodulation	Not critical	19 to 25 dBm
5.13.1 Transmit modulation: EVM	± 2.5 % (for single code)	25 dBm to -21 dBm
5.13.1A Transmit modulation: EVM with HS-DPCCH	± 2.5 % (for single code)	25 dBm to -21 dBm
5.13.2 Transmit modulation: peak code domain error	± 1.0 dB	For readings between -10 dB to -20 dB.
5.13.2A Relative Code Domain Error	± 0.5 dB	Effective Code Domain Power > -30 dB Nominal Code Domain Power > -20 dB
5.13.2B Relative Code Domain Error with HS-DPCCH and E-DCH	± 0.5 dB	Effective Code Domain Power > -30 dB Nominal Code Domain Power > -20 dB
5.13.3 UE phase discontinuity	± 10 Hz for Frequency error ± 2.5 % for EVM (for single code) 6 degree for Phase discontinuity	+25 dBm to -50 dBm +25 dBm to -20 dBm +25 dBm to -50 dBm
5.13.4 PRACH preamble quality (EVM)	± 2.5 %	25 dBm to -21 dBm
5.13.4 PRACH preamble quality (Frequency error)	± 10 Hz	0 to 500 Hz.

F.5.2 Receiver measurements

Table F.5.2: Equipment accuracy for receiver measurements

Clause	Equipment accuracy	Test conditions
6.2 Reference sensitivity level	Not critical	
6.3 Maximum input level:	Not critical	
6.4 Adjacent channel selectivity (Rel-99 and Rel-4)	Not critical	
6.4A Adjacent channel selectivity (Rel-5 and later releases)	Not critical	
6.5 Blocking characteristics	Not critical	
6.6 Spurious Response	Not critical	
6.7 Intermod Characteristics	Not critical	
6.8 Spurious emissions	Not critical	

F.5.3 Performance measurements

Table F.5.3: Equipment accuracy for performance measurements

Clause	Equipment accuracy	Test conditions
7.2 to 7.10	$\frac{DPCH - E_c}{I_{or}}$ ± 0.1 dB	-2.2 to -18.9 dB

F.5.4 Requirements for support of RRM

Table F.5.4: Equipment accuracy for RRM

Clause	Equipment accuracy	Test conditions
8.2.2 to 8.7.8	any_Ec/lor ± 0.1 dB	
	lor//loc ± 0.3 dB	
	loc1/loc2 ± 0.3 dB	
	loc ± 1.0 dB	
	RXLEV ± 1.0 dB	
	loc/ RXLEV ± 0.5 dB	
8.4.2.1A Correct behaviour when receiving an ACK (Release 6 and later)	PRACH timing error ± 0.5 chips	± 10 chips

F.5.5 Performance measurements (HSDPA)

Table F.5.5: Equipment accuracy for performance measurements (HSDPA)

Clause	Equipment accuracy	Test conditions
9.2.1A to 9.2.1G Single Link Performance	$\frac{E_c}{I_{or}}$ ± 0.1 dB	-12, -9, -6 and -3 dB
9.2.2A to 9.2.2D Open loop diversity performance	Same as 9.2.1A	Same as 9.2.1A
9.2.3A to 9.2.3D Closed loop diversity performance	Same as 9.2.1A	Same as 9.2.1A
9.3.1 Single Link Performance - AWGN propagation conditions	Same as 9.2.1A	
9.3.2 Single Link Performance - Fading propagation conditions	Same as 9.2.1A	
9.3.3 Open Loop Diversity Performance - AWGN propagation conditions	Same as 9.2.1A	
9.3.4 Open Loop Diversity Performance - Fading propagation conditions	Same as 9.2.1A	
9.3.5 Closed Loop Diversity Performance - AWGN propagation conditions	Same as 9.2.1A	
9.3.6 Closed Loop Diversity Performance - Fading propagation conditions	Same as 9.2.1A	

F.5.6 Performance measurements (E-DCH)

Table F.5.6: Equipment accuracy for performance measurements (E-DCH)

Clause	Equipment accuracy	Test conditions
10.2.1.1 Detection of E-DCH HARQ ACK Indicator Channel (E-HICH) Single Link Performance (10 ms TTI)	E-HICH_Ec/lor ± 0.1 dB	-35.1 dB
10.2.1.1A Detection of E-DCH HARQ ACK Indicator Channel (E-HICH) Single Link Performance (10 ms TTI, Type 1)	E-HICH_Ec/lor ± 0.1 dB	-38.3 dB
10.2.1.2 Detection of E-DCH HARQ ACK Indicator Channel (E-HICH) Single Link Performance (2 ms TTI)	E-HICH_Ec/lor ± 0.1 dB	-28.3 dB
10.2.1.2A Detection of E-DCH HARQ ACK Indicator Channel (E-HICH) Single Link Performance (2 ms TTI, Type 1)	E-HICH_Ec/lor ± 0.1 dB	-31.7 dB
10.2.2.1.1 Detection of E-DCH HARQ ACK Indicator Channel (E-HICH) in Inter-Cell handover conditions – RLS not containing the serving E-DCH cell (10 ms TTI)	E-HICH_Ec/lor ± 0.1 dB	-23.6 dB
10.2.2.1.1A Detection of E-DCH HARQ ACK Indicator Channel (E-HICH) in Inter-Cell handover conditions – RLS not containing the serving E-DCH cell (10 ms TTI, Type 1)	E-HICH_Ec/lor ± 0.1 dB	-27.8 dB
10.2.2.1.2 Detection of E-DCH HARQ ACK Indicator Channel (E-HICH) in Inter-Cell handover conditions – RLS not containing the serving E-DCH cell (2 ms TTI)	E-HICH_Ec/lor ± 0.1 dB	-16.3 dB
10.2.2.1.2A Detection of E-DCH HARQ ACK Indicator Channel (E-HICH) in Inter-Cell handover conditions – RLS not containing the serving E-DCH cell (2 ms TTI, Type 1)	E-HICH_Ec/lor ± 0.1 dB	-20.7 dB
10.2.2.2.1 Detection of E-DCH HARQ ACK Indicator Channel (E-HICH) in Inter-Cell handover conditions – RLS containing the serving E-DCH cell (10 ms TTI)	E-HICH_Ec/lor ± 0.1 dB	-29.7 dB
10.2.2.2.1A Detection of E-DCH HARQ ACK Indicator Channel (E-HICH) in Inter-Cell handover conditions – RLS containing the serving E-DCH cell (10 ms TTI, Type 1)	E-HICH_Ec/lor ± 0.1 dB	-33.4 dB
10.2.2.2.2 Detection of E-DCH HARQ ACK Indicator Channel (E-HICH) in Inter-Cell handover conditions – RLS containing the serving E-DCH cell (2 ms TTI)	E-HICH_Ec/lor ± 0.1 dB	-23.2 dB
10.2.2.2.2A Detection of E-DCH HARQ ACK Indicator Channel (E-HICH) in Inter-Cell handover conditions – RLS containing the serving E-DCH cell (2 ms TTI, Type 1)	E-HICH_Ec/lor ± 0.1 dB	-27.1 dB
10.3.1.1 Detection of E-DCH Relative Grant Channel (E-RGCH) Single Link Performance (10 ms TTI)	E-RGCH_Ec/lor ± 0.1 dB	-31 dB
10.3.1.1A Detection of E-DCH Relative Grant Channel (E-RGCH) Single Link Performance (10 ms TTI, Type 1)	E-RGCH_Ec/lor ± 0.1 dB	-35 dB
10.3.1.2 Detection of E-DCH Relative Grant Channel (E-RGCH) Single Link Performance (2 ms TTI)	E-RGCH_Ec/lor ± 0.1 dB	-24.4 dB

10.3.1.2A Detection of E-DCH Relative Grant Channel (E-RGCH) Single Link Performance (2 ms TTI, Type 1)	E-RGCH_Ec/lor	± 0.1 dB	-28.6 dB
10.3.2 Detection of E-DCH Relative Grant Channel (E-RGCH) in Inter-Cell Handover conditions	E-RGCH_Ec/lor	± 0.1 dB	-27.3 dB
10.3.2A Detection of E-DCH Relative Grant Channel (E-RGCH) in Inter-Cell Handover conditions (Type 1)	E-RGCH_Ec/lor	± 0.1 dB	-31.2 dB
10.4.1 Demodulation of E-DCH Absolute Grant Channel (E-AGCH) Single Link Performance	E-AGCH_Ec/lor	± 0.1 dB	-23.2 dB
10.4.1A Demodulation of E-DCH Absolute Grant Channel (E-AGCH) Single Link Performance (Type 1)	E-AGCH_Ec/lor	± 0.1 dB	-26.8 dB

F.6 General rules for statistical testing

F.6.1 Statistical testing of receiver BER/BLER performance

F.6.1.1 Error Definition

1) Bit Error Ratio (BER)

The Bit Error Ratio is defined as the ratio of the bits wrongly received to all data bits sent. The bits are the information bits above the convolutional/turbo decoder

2) Block Error Ratio (BLER)

A Block Error Ratio is defined as the ratio of the number of erroneous blocks received to the total number of blocks sent. An erroneous block is defined as a Transport Block, the cyclic redundancy check (CRC) of which is wrong.

F.6.1.2 Test Method

Each test is performed in the following manner:

- a) Setup the required test conditions.
- b) Record the number of samples tested and the number of occurred events (bit error or block error)
- c) Stop the test at a stop criterion which is minimum test time or an early pass or an early fail event.
- d) Once the test is stopped decide according to the pass fail decision rules (subclause F.6.1.7)

F.6.1.3 Test Criteria

The test shall fulfil the following requirements:

- a) good pass fail decision
 - 1) to keep reasonably low the probability (risk) of passing a bad unit for each individual test;
 - 2) to have high probability of passing a good unit for each individual test;
- b) good balance between testtime and statistical significance
 - 3) to perform measurements with a high degree of statistical significance;
 - 4) to keep the test time as low as possible.

F.6.1.4 Calculation assumptions

F.6.1.4.1 Statistical independence

- (a) It is assumed, that error events are rare ($\lim \text{BER BLER} \rightarrow 0$) independent statistical events. However the memory of the convolutional /turbo coder is terminated after one TTI. Samples and errors are summed up every TTI. So the assumption of independent error events is justified.
- (b) In the BLER test with fading there is the memory of the multipath fading channel which interferes the statistical independence. A minimum test time is introduced to average fluctuations of the multipath fading channel. So the assumption of independent error events is justified approximately.

F.6.1.4.2 Applied formulas

The formulas, applied to describe the BER BLER test, are based on the following experiments:

- (1) After having observed a certain number of errors (**ne**) the number of samples are counted to calculate BER BLER. Provisions are made (note 1) such that the complementary experiment is valid as well:
- (2) After a certain number of samples (**ns**) the number of errors, occurred, are counted to calculate BER BLER.

Experiment (1) stipulates to use the following Chi Square Distribution with degree of freedom ne :
 $2 * \text{dchisq}(2 * NE, 2 * ne)$.

Experiment (2) stipulates to use the Poisson Distribution: $\text{dpois}(ne, NE)$

(NE: mean of the distribution)

To determine the early stop conditions, the following inverse cumulative operation is applied:

$0.5 * \text{qchisq}(D, 2 * ne)$. This is applicable for experiment (1) and (2).

D: wrong decision risk per test step

Note: other inverse cumulative operations are available, however only this is suited for experiment (1) and (2).

F.6.1.4.3 Approximation of the distribution

The test procedure is as follows:

During a running measurement for a UE ns (number of samples) and ne (number of errors) are accumulated and from this the preliminary BER BLER is calculated. Then new samples up to the next error are taken. The entire past and the new samples are basis for the next preliminary BER BLER. Depending on the result at every step, the UE can pass, can fail or must continue the test.

As early pass- and early fail-UEs leave the statistical totality under consideration, the experimental conditions are changed every step resulting in a distribution that is truncated more and more towards the end of the entire test. Such a distribution can not any more be handled analytically. The unchanged distribution is used as an approximation to calculate the early fail and early pass bounds.

F.6.1.5 Definition of good pass fail decision.

This is defined by the probability of wrong decision F at the end of the test. The probability of a correct decision is $1-F$.

The probability (risk) to fail a good DUT shall be $\leq F$ according to the following definition: A DUT is failed, accepting a probability of $\leq F$ that the DUT is still better than the specified error ratio (Test requirement).

The probability to pass a bad DUT shall be $\leq F$ according to the following definition: A DUT is passed, accepting a probability of $\leq F$ that the DUT is still worse than M times the specified error ratio. ($M > 1$ is the bad DUT factor).

This definitions lead to an early pass and an early fail limit:

Early fail: $\text{ber} \geq \text{berlim}_{\text{fail}}$

$$\text{berlim}_{\text{fail}}(D, ne) = \frac{2 * ne}{\text{qchisq}(D, 2 * ne)} \quad (1)$$

For $ne \geq 7$

Early pass: $ber \leq ber_{limbad}_{pass}$

$$ber_{limbad}_{pass}(D, ne) = \frac{2 * ne * M}{qchisq(1 - D, 2 * ne)} \quad (2)$$

For $ne \geq 1$

With

ber (normalized BER,BLER): BER,BLER according to F.6.1.1 divided by Test requirement

D: wrong decision probability for a test step . This is a numerically evaluated fraction of F, the wrong decision probability at the end of the test. See table F.6.1.6.1.

ne: Number of error events

M: bad DUT factor see table F.6.1.6.1.

qchisq: inverse cumulative chi squared distribution

F.6.1.6 Good balance between testtime and statistical significance

Three independent test parameters are introduced into the test and shown in Table F.6.1.6.1. These are the obvious basis of test time and statistical significance. From the first two of them four dependent test parameters are derived. The third independent test parameter is justified separately.

Table F.6.1.6.1 independent and dependent test parameters

Independent test parameters			Dependent test parameters		
Test Parameter	Value	Reference	Test parameter	Value	Reference
Bad DUT factor M	1.5	Table F.6.1.8	Early pass/fail condition	Curves	Subclause F.6.1.5 Figure 6.1.9
Final probability of wrong pass/fail decision F	0.2% 0.02%, note 2	Subclause F.6.1.5	Target number of error events	345	Table 6.1.8
			Probability of wrong pass/fail decision per test step D	0.0085% 0.0008% and 0.008%, note 2	
			Test limit factor TL	1.234]	Table 6.1.8
Minimum test time		Table F.6.1.6.2			

The minimum test time is derived from the following justification:

- 1) For no propagation conditions and static propagation condition

No early fail calculated from fractional number of errors <1 (see note 1)

- 2) For multipath fading condition

No stop of the test until 990 wavelengths are crossed with the speed given in the fading profile.

- 3) For birth death propagation conditions

No stop of the test until 200 birth death transitions occur

- 4) For moving propagation conditions: 628 sec

This is necessary in order to pass all potential critical points in the moving propagation profile 4 times:

- Maximum rake window
- Maximum adjustment speed
- Intersection of moving taps

5) For high speed train conditions

This corresponds 4 complete cycles of approach and leave to and from a BS antenna.

Table F.6.1.6.2 : minimum Test time

Fading profile	Minimum test time
Multipath propagation 3 km/h	164 sec
Multipath propagation 50 km/h	9.8 sec
Multipath propagation 120 km/h	4.1 sec
Multipath propagation 250 km/h	2 sec
Birth Death propagation	38.2 sec
Moving propagation	628 sec
High speed train conditions	28.8 sec

In table F.6.1.8 the minimum test time is converted in minimum number of samples.

F.6.1.7 Pass fail decision rules

No decision is allowed before the minimum test time is elapsed.

- 1) If minimum Test time < time for target number of error events then the following applies: The required confidence level $1-F$ (= correct decision probability) shall be achieved. This is fulfilled at an early pass or early fail event.

For BER:

For every TTI (Transmit Time Interval) sum up the number of bits (n_s) and the number if errors (n_e) from the beginning of the test and calculate

BER_1 (including the artificial error at the beginning of the test (Note 1))and

BER_0 (excluding the artificial error at the beginning of the test (Note 1)).

If BER_0 is above the early fail limit, fail the DUT.

If BER_1 is below the early pass limit, pass the DUT.

Otherwise continue the test

For BLER:

For every block sum up the number of blocks (n_s) and the number of erroneous blocks (n_e) from the beginning of the test and calculate

$BLER_1$ (including the artificial error at the beginning of the test (Note 1))and

$BLER_0$ (excluding the artificial error at the beginning of the test (Note 1)).

If $BLER_1$ is below the early pass limit, pass the DUT.

If $BLER_0$ is above the early fail limit, fail the DUT.

Otherwise continue the test

- 2) If the minimum test time \geq time for target error events, then the test runs for the minimum test time and the decision is done by comparing the result with the test limit.

For BER:

For every TTI (Transmit Time Interval) sum up the number of bits (ns) and the number of errors (ne) from the beginning of the test and calculate BER_0

For BLER:

For every block sum up the number of blocks (ns) and the number of erroneous blocks (ne) from the beginning of the test and calculate $BLER_0$

If $BER_0/BLER_0$ is above the test limit, fail the DUT.

If $BER_0/BLER_0$ is on or below the test limit, pass the DUT.

F.6.1.8 Test conditions for BER, BLER, RLC SDU Error Rate tests

Table F.6.1.8: Test conditions for a single BER/BLER tests

Type of test (BER)	Test requirement (BER/BLER)	Test limit (BER/BLER) = Test requirement (BER/BLER) x TL TL	Target number of error events (time)	Minimum number of samples	Prob that good unit will fail = Prob that bad unit will pass [%]	Bad unit BER/BLER factor M
Reference Sensitivity Level	0.001	1.234	345 (22.9s)	Note 1	0.2	1.5
Maximum Input Level	0.001	1.234	345 (22.9s)	Note 1	0.2	1.5
Adjacent Channel Selectivity	0.001	1.234	345 (22.9s)	Note 1	0.2	1.5
Blocking Characteristics Pass condition Note 2	0.001	1.251	403 (26.4s)	Note 1	0.2	1.5
Blocking Characteristics Fail condition Note 2	0.001	1.251	403 (26.4s)	Note 1	0.02	1.5
Spurious Response	0.001	1.234	345 (22.9s)	Note 1	0.2	1.5
Intermodulation Characteristics	0.001	1.234	345 (22.9s)	Note 1	0.2	1.5
HS-SCCH Detection Performance	0.05	1.234	345 (34s)	Note 1	0.2	1.5
	0.01	1.234	345 (168s)	Note 1	0.2	1.5

Table F.6.1.8-2: Test conditions for BLER tests

Type of test (BLER)	Information Bit rate	Test requirement (BER/BLER)	Test limit (BER/BLER)= Test requirement (BER/BLER)x TL TL	Target number of error events (time)	Minimum number of samples	Prob that bad unit will pass = Prob that good unit will fail [%]	Bad unit BER/BLER factor M
Demodulation in Static Propagation conditions	12.2 64 144 384	0.01 0.1 0.01 0.01 0.1 0.01	1.234	345 (559.16s) (55.92s) (559.16s) (55.92s) (559.16s) (27.96s) (279.58s)	Note1	0.2	1.5
Demodulation of DCH in Multi-path Fading Propagation conditions							
3km/h (Case 1, Case 2, Case 4)	12.2 64 144 384	0.01 0.1 0.01 0.1 0.01 0.1 0.01	1.234	345 (559.16s) (55.92s) (559.16s) (55.92s) (559.16s) (27.96s) (279.58s)	8200 8200 8200 8200 8200 16400 16400	0.2	1.5
120 km/h (Case3)	12.2 64 144 384	0.01 0.1 0.01 0.1 0.01 0.1 0.01	1.234	345 (559.16s) (55.92s) (559.16s) (55.92s) (559.16s) (27.96s) (279.58s)	205 205 205 205 205 410 410	0.2	1.5
250 km/h (Case 6)	12.2 64 144 384	0.01 0.1 0.01 0.1 0.01 0.1 0.01	1.234	345 (559.16s) (55.92s) (559.16s) (55.92s) (559.16s) (27.96s) (279.58s)	100 100 100 100 100 200 200	0.2	1.5
Demodulation of DCH in Moving Propagation conditions	12.2 64	0.01 0.01	1.234	345 (559.16)	31400 31400	0.2	1.5
Demodulation of DCH in Birth-Death Propagation conditions	12.2 64	0.01 0.01	1.234	345 (559.16s) (559.16s)	1910 1910	0.2	1.5
Demodulation of DCH in high speed train conditions	12.2	0.01	1.234	345 (559.16s)	1440	0.2	1.5

Demodulation of DCH in Base Station Transmit diversity modes (3 km/h, case1)	12.2	0.01	1.234	345 (559.16s)	8200	0.2	1.5
Demodulation of DCH in closed loop transmit diversity mode (3 km/h, case1) Mode 1	12.2	0.01	1.234	345 (559.16s)	8200	0.2	1.5
Mode 2	12.2	0.01		(559.16s)	8200		
Demodulation of DCH in Site Selection Diversity Transmission Power Control mode	12.2	0.01	1.234	345 (559.16)	8200	0.2	1.5
Demodulation of DCH in Inter-Cell Soft Handover (120 km/h, case3)	12.2 64 144 384	0.01 0.1 0.01 0.1 0.01 0.1	1.234	345 (559.16s) (55.92s) (559.16s) (55.92s) (559.16s) (27.96s) (279.58s)	205 205 205 205 205 410 410	0.2	1.5
Combining of TPC commands from radio links of different radio link sets				Not applicable			
Power control in the downlink, constant BLER target				Not applicable			
Power control in the downlink, initial convergence				Not applicable			
Power control in the downlink, wind up effects				Not applicable			
Power control in the downlink, different transport formats				Not applicable			
Downlink compressed mode				Not applicable			

Blind transport format detection	Static	BLER	FDR	1.234	345	Note 1	0.2	1.5	
		10^{-2}	10^{-4}		BLER				FDR
		12.2	559.16s		932min				559.16s
	7.95	10^{-2}	10^{-4}			Note 1			
	1.95	10^{-2}	10^{-4}			Note 1			
	Multipath	12.2	10^{-2}	10^{-4}		559.16s	932min	205	
7.95		10^{-2}	10^{-4}		559.16s	932min	205		
1.98		10^{-2}	10^{-4}		559.16s	932min	205		

Table F.6.1.8-3: Test conditions for RLC SDU Error Rate (SDU ER) tests

Type of test (SDU ER)	Test requirement (SDU ER)	Test limit (SDU ER)= Test requirement (SDU ER)x TL TL	Target number of error events	Minimum number of samples	Prob that good unit will fail = Prob that bad unit will pass [%]	Bad unit SDU ER factor M
Cell re-selection during an MBMS session, one UTRAN inter-frequency and 2 GSM cells present in the neighbour list	0.04	1.236	NA	NA	5%	1.5
			The SDU ER test is embedded in the Cell reselection delay test and its test duration depends on the test duration of the delay test. During the cell reselection delay test more samples than necessary for statistical significance are generated in the SDU ER test. (approx factor 50). Hence, after finalisation of the delay test, the SDU ER test is decided against the test limit: $0.04 \times 1.236 = 0.0495$			

F.6.1.9 Practical Use (informative)

See figure F.6.1.9:

The early fail limit represents formula (1) in F.6.1.5. The range of validity is $n_e \geq 7, \geq 8$ in case of blocking test to $n_e = 345$

The early pass limit represents the formula (2) in F.6.1.5. The range of validity is $n_e = 1$ to $n_e = 345$. See note 1

The intersection co-ordinates of both curves are : number of errors $n_e = 345$ and test limit $TL = 1.234$.

The range of validity for TL is $n_e > 345$.

A typical BER BLER test, calculated from the number of samples and errors (F.6.1.2.(b)) using experimental method (1) or (2) (see F.6.1.4. calculation assumptions) runs along the yellow trajectory. With an errorless sample the trajectory goes down vertically. With an erroneous sample it jumps up right. The tester checks if the BER BLER test intersects the early fail or early pass limits. The real time processing can be reduced by the following actions:

BLER₀ (excluding the artificial error at the beginning of the test (Note 1)). is calculated only in case of an error event.

BER₀ (excluding the artificial error at the beginning of the test (Note 1)). is calculated only in case of an error event within a TTI.

So the early fail limit cannot be missed by errorless samples.

The check against the early pass limit may be done by transforming formula (2) in F.6.1.5 such that the tester checks against a Limit-Number-of-samples (NL(ne)) depending on the current number of errors (including the artificial error at the beginning of the test (Note 1)).

Early pass if

$$NL(ne) \geq \frac{qchisq(1 - D, 2 * ne)}{2 * TR * M}$$

TR: test requirement (0.001)

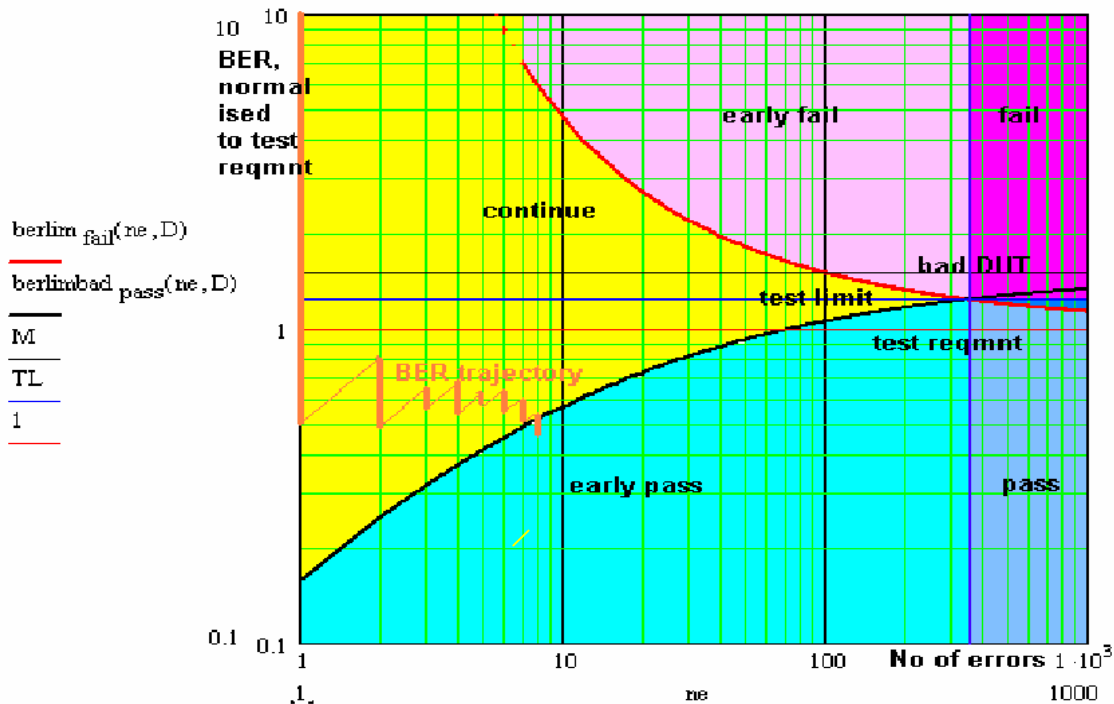

Figure F.6.1.9

Note 1: At the beginning of the test, an artificial error is introduced. This ensures that an ideal DUT meets the valid range of the early pass limit. In addition this ensures that the complementary experiment (F.6.1.4. bullet point (2)) is applicable as well.

For the check against the early fail limit the artificial erroneous sample, introduced at the beginning of the test, is disregarded.

Due to the nature of the test, namely discrete error events, the early fail condition shall not be valid, when fractional errors <1 are used to calculate the early fail limit: Any early fail decision is postponed until number of errors $ne \geq 7$. In the blocking test any early fail decision is postponed until number of errors $ne \geq 8$.

Note2: $F = 0.2\%$ is intended to be used for a test containing a few BER/BLER tests (e.g. receiver sensitivity is repeated 12 times). For a test containing many BER/BLER tests (e.g. blocking test) this value is not appropriate for a single BER/BLER test.

The blocking test contains approx. 12750 single BER tests. A DUT on the limit will fail approx. 25 to 26 times due to statistical reasons (wrong decision probability at the end of the test $F = 0.2\%$). 24 fails are allowed in the blocking test but they are reserved for spurious responses. This shall be solved by the following rule:

All passes (based on $F=0.2\%$) are accepted, including the wrong decisions due to statistical reasons.

An early fail limit based on $F=0.02\%$ instead of 0.2% is established, that ensures that wrong decisions due to statistical reasons are reduced to 2 to 3.

These asymmetric test conditions ensure that a DUT on the test limit consumes hardly more test time for a blocking test than in the symmetric case and on the other hand discriminates sufficiently between statistical fails and spurious response cases.

F.6.1.10 Dual limit BLER tests

This annex is applicable for subclause 7.8.1 Power control in the downlink constant BLER target, subclause 7.8.4 Power control in the downlink, different transport formats and subclause 7.9 Downlink compressed mode. In this tests the BLER shall stay between two limits.

Table F.6.1.10. Parameters for single and dual limit BLER

Parameters for single limit	Parameters for dual limits
Specified BER BLER	{ Specified BLER * 1.3 (upper test requirement) Specified BLER * 0.7 (lower test requirement)
Bad DUT BER BLER	{ Bad DUT BLER *1.3 Bad DUT BLER *0.7
Test limit	{ Upper Test limit Lower Test limit
Early fail and Early pass	{ Fail_high Pass_high Pass_low Fail_low

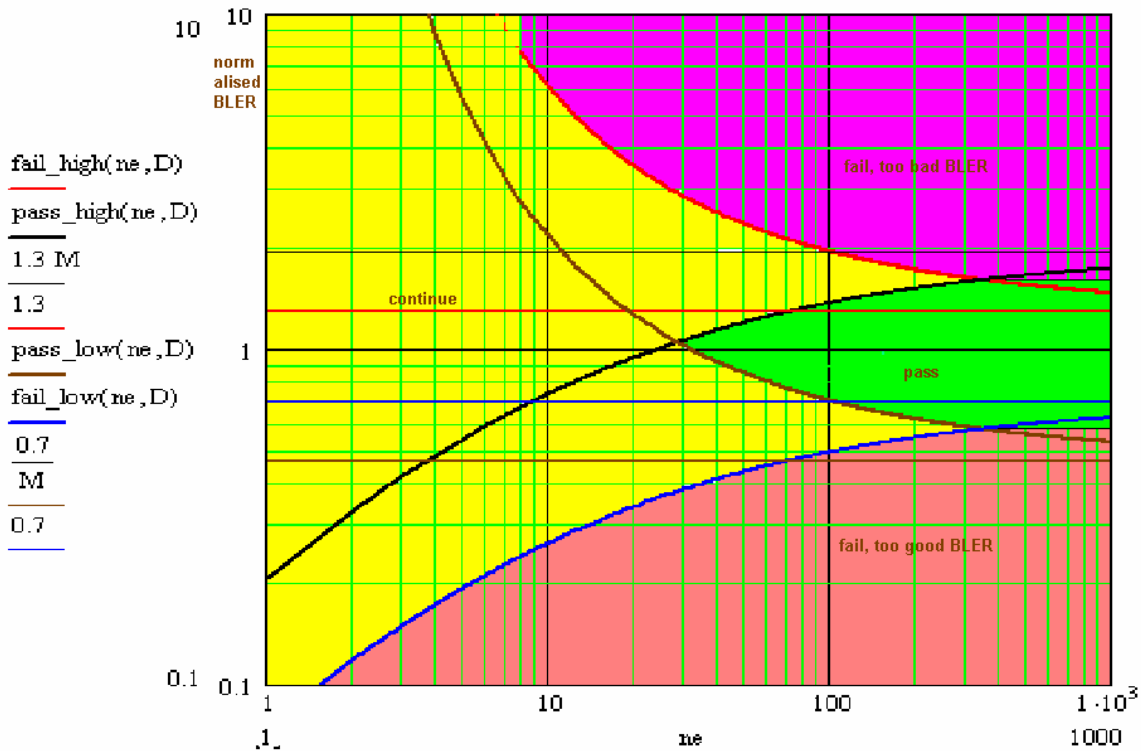

Figure F.6.1.10: Dual limit BLER

F.6.1.10.1 Description of the parameters for dual limit BLER tests

(refer figure F.6.1.10)

The origin

1 (black horizontal line in the centre): this is the normalised origin BLER

The asymptotes

1.3 (red horizontal line): this is the specified upper limit of the range (BLER +30%) (upper test requirement)

0.7 (blue horizontal line): this is the specified lower limit of the range (BLER-30%) (lower test requirement)

1.3*M (black horizontal line): this is M times the specified upper limit of the range (Bad DUT BLER)

0.7/M (brown horizontal line): this is 1/M times the specified lower limit. (Bad DUT BLER)

The pass/fail limits

Fail_high (bold red curve):

Definition: A momentary BLER value above this curve is with high probability above the specified upper limit: BLER +30%.

Verdict: Above: Fail due to bad BLER

Below: continue

It approaches towards 1.3 (red).

Validity range $7 < errors < 345$.

Formula:

$$\text{fail_high}(ne, D) := 2 \cdot \frac{ne \cdot 1.3}{qchisq(D, 2 \cdot ne)}$$

Fail_low (bold blue curve):

Definition: A momentary BLER value below this curve is with high probability below the specified lower limit: BLER -30%.

Verdict: Above: continue

Below: Fail due to too good BLER

It approaches towards 0.7(blue).

Validity range $1 \leq \text{errors} < 343$.

Formula:

$$\text{fail_low}(ne, D) := 2 \cdot \frac{ne \cdot 0.7}{qchisq(1 - D, 2 \cdot ne)}$$

Pass_high (bold black curve):

Definition: a momentary BLER value on and below this curve is with high probability below M times the specified upper limit.

Verdict: Above: continue

Below: pass for $ne \geq 29$

continue for $ne < 29$

It approaches $1.3 \cdot M$ (black).

Validity range $1 \leq \text{errors} < 345$.

Formula:

$$\text{pass_high}(ne, D) := 2 \cdot \frac{ne}{qchisq(1 - D, 2 \cdot ne)} \cdot M \cdot 1.3$$

Pass_low (bold brown curve):

Definition: a momentary BLER value on and above this curve is with high probability above $1/M$ times the specified lower limit of the range.

Verdict: Above: pass for $ne \geq 29$,

continue for $ne < 29$

Below: continue

It approaches $0.7/M$ (brown).

Validity range $7 < \text{errors} < 343$.

$$\text{pass_low}(ne, D) := 2 \cdot \frac{ne \cdot \frac{0.7}{M}}{qchisq(D, 2 \cdot ne)}$$

Legende formulas:

D: wrong decision risk per test step: 0.000085

M: bad DUT factor: 1.5

ne: number of errors

qchisq: inverse cumulative chi square function

Upper test limit (boarder between pink and green) $1.3 * 1.234 = 1.6$

Validity range: $345 \leq \text{errors}$.

Verdict: Above: fail due to bad BLER

Below: pass

Lower test limit (boarder between green and orange) $0.7 / 1.234 = 0.567$

Validity range: $343 \leq \text{errors}$

Verdict: Above: pass

Below: fail due to too good BLER

The intersection co-ordinates:

Fail_high (bold red curve) and Pass_high (bold black curve):

Upper target number of errors (345) and upper test limit: $1.3 * 1.234$

Fail_low (bold blue curve) and Pass_high (bold black curve):

Lower target number of errors (343) and lower test limit: $0.7 / 1.234$

Pass_high (bold black curve) and Pass_low (bold brown curve)

Minimum number of errors (29) and optimum normalised BLER (1.049)

The ranges:

Range(pink): in this range the measurement can be stopped and the DUT is failed due to too high BLER.

Range (orange): in this range the measurement can be stopped and the DUT is failed due to too low BLER.

Range (yellow): in this range the measurement is undecided and must be continued.

Range (green): in this range the measurement can be stopped and the DUT is passed. No final BLER result is achieved.

F.6.1.10.2 Pass fail decision rules

No decision is allowed before the minimum test time (Table F.6.1.6.2) has elapsed

- 1) If minimum Test time < time for target number of error events then the following applies: The required confidence level $1-F$ (= correct decision probability, Table F.6.1.6.2) shall be achieved. This is fulfilled at

fail_high

pass_high

pass_low

fail_low

For every block sum up the number of blocks (ns) and the number of erroneous blocks (ne) from the beginning of the test and calculate

$BLER_1$ (including the artificial error at the beginning of the test (Note 1, F.6.1.9))and

$BLER_0$ (excluding the artificial error at the beginning of the test (Note 1, F.6.1.9)).

If $BLER_0$ is above *fail_high*, fail the test due to too bad BLER

If $BLER_1$ is below *fail_low*, fail the test due to too good BLER

If $BLER_0$ is on or below *fail_high* and if $BLER_1$ is above *pass_high*, continue the test

If $BLER_0$ is below *pass_low* and if $BLER_1$ is above or on *fail_low*, continue the test

If $BLER_1$ is below or on *pass_high* and if $BLER_0$ is on or above *pass_low*, pass the test

- 2) If the minimum test time \geq time for target error events, then the test runs for the minimum test time and the decision is done by comparing the result with the upper and lower test limit.

If $BLER_0$ is above the upper test limit, fail the DUT due to too bad BLER

If $BLER_1$ is below the lower test limit, fail the DUT due to too good BLER

If $BLER_0$ is on or below the upper test limit and if $BLER_1$ is on or above the lower test limit, pass the DUT

F.6.1.10.3 Test conditions for dual limit BLER tests

Table F.6.1.10.3 Test conditions for dual limit BLER tests

Type of test (BLER)	Data rate, Propagation condition	Test requirement (BLER)	Test limit = Test requirement * TL TL	Target number of error events (time)	Minimum number of samples	Prob that a good unit will fail = prob that a bad unit will pass: F[%]	Bad unit factor M
Power control in the downlink, constant BLER target	12.2 kbit/s, 3km/h (case4)	0.01±30%	Upper TL: 1.3*1.234 Lower TL 0.7/1.234	Upper: 345 (431.25s) Lower 343 (1191s)	8200	0.2	Upper: 1.5 Lower 1/1.5
Downlink compressed mode	12.2kbit/s, 3km/h (case 2)	0.01±30%	Upper TL: 1.3*1.234 Lower TL 0.7/1.234	Upper: 345 (431.25s) Lower 343 (1191s)	8200	0.2	Upper: 1.5 Lower 1/1.5
Power control in the downlink, different transport formats	12.2 kbit/s, 3km/h 0 kbit/s, 3km/h (case 4)	0.01±30%	Upper TL: 1.3*1.234 Lower TL 0.7/1.234	Upper: 345 (431.25s) Lower 343 (1191s)	8200	0.2	Upper: 1.5 Lower 1/1.5

F.6.2 Statistical testing of RRM delay performance

F.6.2.1 Test Method

Each test is performed in the following manner:

- a) Setup the required test conditions.
- b) Measure the delay repeated times. Start each repetition after sufficient time, such that each delay test is independent from the previous one. The delay-times, measured, are simplified to:
 - a good delay, if the measured delay is \leq limit.
 - a bad delay, if the measured delay is $>$ limit
- c) Record the number of delays (ns), tested, and the number of bad delays (ne)
- d) Stop the test at an early pass or an early fail event.

e) Once the test is stopped, decide according to the pass fail decision rules (subclause F.6.2.7)

F.6.2.2 Bad Delay Ratio (ER)

The Bad Delay Ratio (ER) is defined as the ratio of bad delays (ne) to all delays (ns).
(1-ER is the success ratio)

F.6.2.3 Test Criteria

The test shall fulfil the following requirements:

- a) good pass fail decision
 - 1) to keep reasonably low the probability (risk) of passing a bad unit for each individual test;
 - 2) to have high probability of passing a good unit for each individual test;
- b) good balance between test-time and statistical significance
 - 3) to perform measurements with a high degree of statistical significance;
 - 4) to keep the test time as low as possible.

F.6.2.4 Calculation assumptions

F.6.2.4.1 Statistical independence

It is arranged by test conditions, that bad delays are independent statistical events.

F.6.2.4.2 Applied formulas

The specified ER is 10% in most of the cases. This stipulates to use the binomial distribution to describe the RRM delay statistics. With the binomial distribution optimal results can be achieved. However the inverse cumulative operation for the binomial distribution is not supported by standard mathematical tools. The use of the Poisson or Chi Square Distribution requires $ER \rightarrow 0$. Using one of this distributions instead of the binomial distribution gives sub-optimal results in the conservative sense: a pass fail decision is done later than optimal and with a lower wrong decision risk than predefined.

The formulas, applied to describe the RRM delay statistics test, are based on the following experiment:

- (1) After having observed a certain number of bad delays (**ne**) the number of all delays (**ns**) are counted to calculate ER. Provisions are made (note 1) such that the complementary experiment is valid as well:
- (2) After a certain number of delays (**ns**) the number of bad delays (**ne**), occurred, are counted to calculate ER.

Experiment (1) stipulates to use the Chi Square Distribution with degree of freedom ne: $2 * dchisq(2 * NE, 2 * ne)$.

Experiment (2) stipulates to use the Poisson Distribution: $dpois(ne, NE)$

(NE: mean value of the distribution)

To determine the early stop conditions, the following inverse cumulative operation is applied:

$0.5 * qchisq(D, 2 * ne)$ for experiment (1) and (2)

D: wrong decision risk per test step

Note: Other inverse cumulative operations are available, however only this is suited for experiment (1) and (2).

F.6.2.4.3 Approximation of the distribution

The test procedure is as follows:

During a running measurement for a UE ns (Number of Delays) and ne (Number of bad delays) are accumulated and from this the preliminary ER is calculated. Then new samples up to the next bad delay are taken. The entire past and

the new samples are basis for the next preliminary ER. Depending on the result at every step, the UE can pass, can fail or must continue the test.

As early pass- and early fail-UEs leave the statistical totality under consideration, the experimental conditions are changed every step resulting in a distribution that is truncated more and more towards the end of the entire test. Such a distribution can not any more be handled analytically. The unchanged distribution is used as an approximation to calculate the early fail and early pass bounds.

F.6.2.5 Definition of good pass fail decision

This is defined by the probability of wrong decision F at the end of the test. The probability of a correct decision is 1- F.

The probability (risk) to fail a good DUT shall be $\leq F$ according to the following definition: A DUT is failed, accepting a probability of $\leq F$ that the DUT is still better than the specified bad delay ratio (Test requirement).

The probability (risk) to pass a bad DUT shall be $\leq F$ according to the following definition: A DUT is passed, accepting a probability of $\leq F$ that the DUT is still worse than M times the specified bad delay ratio. ($M \geq 1$ is the bad DUT factor).

This definitions lead to an early pass and an early fail limit:

Early fail: $er \geq erlim_{fail}$

$$erlim_{fail}(D, ne) = \frac{2 * ne}{qchisq(D, 2 * ne)} \quad (1)$$

For $ne \geq 5$

Early pass: $er \leq erlim_{pass}$

$$erlim_{pass}(D, ne) = \frac{2 * ne * M}{qchisq(1 - D, 2 * ne)} \quad (2)$$

For $ne \geq 1$

With

er (normalized ER): ER according to F.6.2.2 divided by specified ER

D: wrong decision probability for a test step . This is a numerically evaluated fraction of F, the wrong decision probability at the end of the test. see table F.6.2.6.1

ne: Number of bad delays

M: bad DUT factor see table F.6.2.6.1

qchisq: inverse cumulative chi squared distribution

F.6.2.6 Good balance between test-time and statistical significance

Two independent test parameters are introduced into the test and shown in Table F.6.2.6.1. These are the obvious basis of test time and statistical significance. From them four dependent test parameters are derived.

Table F.6.2.6 independent and dependent test parameters

Independent test parameters			Dependent test parameters		
Test Parameter	Value	Reference	Test parameter	Value	Reference
Bad DUT factor M	1.5	Table F.6.1.8	Early pass/fail condition	Curves	Subclause F.6.2.5 Figure 6.2.9
Final probability of wrong pass/fail decision F	5%	Table F.6.2.8	Target number of bad delays	154	Table 6.2.8
			Probability of wrong pass/fail decision per test step D	0.6 %	
			Test limit factor TL	1.236]	Table 6.2.8

F.6.2.7 Pass fail decision rules

The required confidence level $1-F$ (= correct decision probability) shall be achieved. This is fulfilled at an early pass or early fail event. Sum up the number of all delays (ns) and the number of bad delays from the beginning of the test and calculate:

ER_1 (including the artificial error at the beginning of the test (Note 1))and

ER_0 (excluding the artificial error at the beginning of the test (Note 1)).

If ER_0 is on or above the early fail limit, fail the DUT.

If ER_1 is on or below the early pass limit, pass the DUT.

Otherwise continue the test

F.6.2.8 Test conditions for RRM delay tests, Combining of TPC commands test 1, Demodulation of Paging channel and Detection of acquisition indicator tests.

Table F.6.2.8: Test conditions for a single RRM delay tests, Combining of TPC commands test 1, Demodulation of Paging channel and Detection of Acquisition indicator tests.

Type of test	Test requirement Delay (s)	Test requirement (ER= 1-success ratio)	Testlimit(ER)= Test requirement (ER)x TL TL	Target number of bad delays	Prob that good unit will fail = Prob that bad unit will pass [%]	Bad unit factor M
7.7.2 Combining of TPC commands Test 1 Note: The theory of statistical testing of RRM delay performance in clause F.6.2 is applied for test case 7.7.2 Combining of TPC commands Test 1. The success ratio for delay is replaced by the success ratio for power control sequence.	Not applicable	0.01	1.236	154	5	1.5
7.7.3 Combining of reliable TPC commands from radio links of different radio link sets Note: The theory of statistical testing of RRM delay performance in clause F.6.2 is applied for test case 7.7.3 Combining of reliable TPC commands from radio links of different radio link sets Test 1 and Test 2. The success ratio for delay is replaced by the success ratio for power control sequence.	Not applicable	0.1	1.236	154	5	1.5
7.11 Demodulation of Paging Channel (PCH) Note: The theory of statistical testing of RRM delay performance in clause F.6.2 is applied for test case 7.11 Demodulation of Paging Channel. The success ratio for delay is replaced by the success ratio for procedure step 4.	Not applicable	0.01	1.236	154	5	1.5
7.12 Detection of Acquisition indicator (AI). Note: The theory of statistical testing of RRM delay performance in clause F.6.2 is applied for test case 7.12. The success ratio for delay is replaced by the success ratio for procedure steps 5, 6 and 12.	Not applicable	0.01	1.236	154	5	1.5
8.2.2 Cell reselection	8	0.1	1.236	154	5	1.5
8.2.3.1 UTRAN to GSM cell reselection, scenario 1	27.9	0.1	1.236	154	5	1.5
8.2.3.2 UTRAN to GSM cell reselection, scenario 2	9.6	0.1	1.236	154	5	1.5
8.2.3.3 UTRAN to GSM cell reselection, scenario 3	39.6	0.1	1.236	154	5	1.5
8.2.4 FDD/TDD Cell reselection	8	0.1	1.236	154	5	1.5
8.3.1 FDD/FDD Soft handover	NA					

8.3.2 FDD FDD Hard Handover						
8.3.2.1 Handover to intra frequency cell	110 ms	0.1	1.236	154	5	1.5
8.3.2.2 Handover to interfrequency cell	140ms	0.1	1.236	154	5	1.5
8.3.4 UTRAN to GSM HandOver	100 ms	0.01	1.236	154	5	1.5
8.3.6.3 Cell re-selection during an MBMS session, one UTRAN inter-frequency and 2 GSM cells present in the neighbour list	4.65 s	0.1	1.236	154	5	1.5
8.3.8 Serving HS-DSCH cell change	75 ms, 85 ms	0.01	1.236	154	5	1.5
8.4.3. Transport format combination selection in UE.	140ms (see 8.4.3.1.4.2 step 7)	0.1	1.236	154	5	1.5
8.4.4.1: 10 ms TTI E-DCH E-TFC restriction	50ms	0.1	1.236	154	5	1.5
8.4.4.2: 2 ms TTI E-DCH E-TFC restriction	31ms	0.1	1.236	154	5	1.5
8.6.2.2 correct reporting of neighbours in fading propagation condition.	[13.9 s] (see procedure 8.6.2.2.4.2 step 8.)	0.1	1.236	154	5	1.5
8.6.2.3 correct reporting of neighbours in fading propagation condition using TGL1=14.	[1.78 s] (see procedure 8.6.2.3.4.2 step 8.)	0.1	1.236	154	5	1.5
8.7.3 AGSM Carrier SSI Note: The theory of statistical testing of RRM delay performance in clause F.6.2 is applied for test case 8.7.3A. The success ratio for delay is replaced by the success ratio in procedure step 7	Not applicable	0.01	1.236	154	5	1.5
8.7.9 UE Transmission Power Headroom. Note: The theory of statistical testing of RRM delay performance in clause F.6.2 is applied for test case 8.7.9. The success ratio for delay is replaced by the success ratio in procedure step 7	Not applicable	0.1	1.236	154	5	1.5

F.6.2.9 Practical Use (informative)

See figure F.6.2.9:

The early fail limit represents formula (1) in F.6.2.5. The range of validity is $n_e \geq 5$ to $n_e = 154$

The early pass limit represents the formula (2) in F.6.2.5. The range of validity is $n_e=1$ to $n_e=154$. See note 1. The intersection co-ordinates of both curves are: target number of bad delays $n_e = 154$ and test limit $TL = 1.236$.

A typical delay test, calculated from the number of samples and errors (F.6.2.2) using experimental method (1) or (2) (see F.6.2.4.2. calculation assumptions) runs along the yellow trajectory. With an good delay the trajectory goes down vertically. With a bad delay it jumps up right. The tester checks if the ER test intersects the early fail or early pass limits.

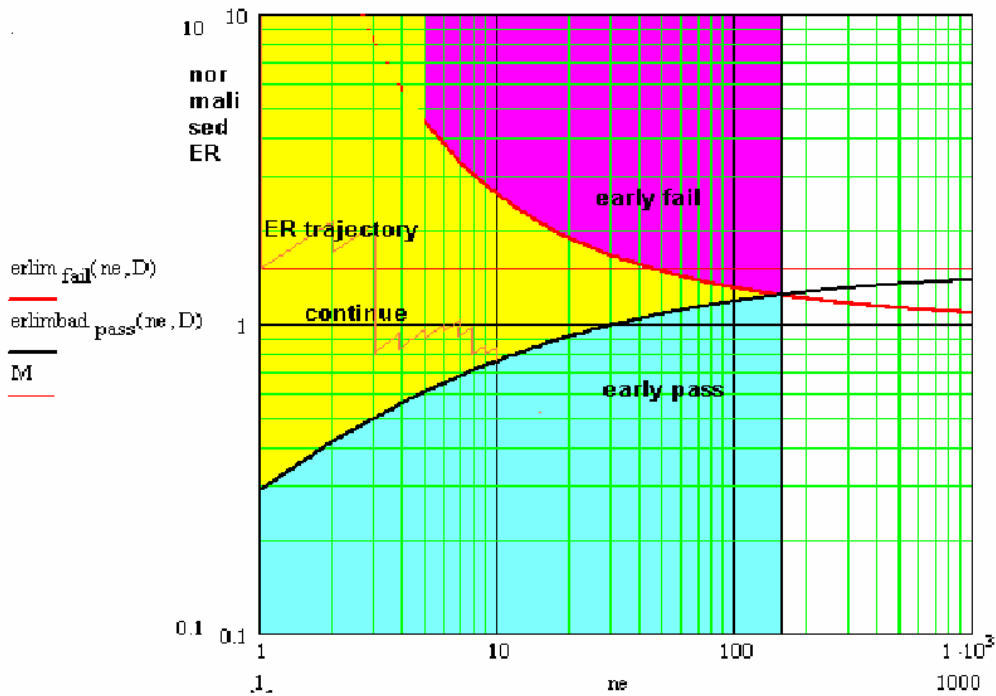

Figure F.6.2.9

Note 1: At the beginning of the test, an artificial bad delay is introduced. This ensures that an ideal DUT meets the valid range of the early pass limit. In addition this ensures that the complementary experiment (F.6.2.4.2. bullet point (2)) is applicable as well. For the check against the early fail limit the artificial bad delay sample, introduced at the beginning of the test, is disregarded.

Due to the nature of the test, namely discrete bad delay events, the early fail condition shall not be valid, when fractional bad delays <1 are used to calculate the early fail limit: Any early fail decision is postponed until number of errors $ne \geq 5$.

F.6.3 Statistical Testing of HSDPA Receiver Performance

F.6.3.1 Definition

Information Bit Throughput R:

The measured information bit throughput R is defined as the sum (in kilobits) of the information bit payloads (excluding the 24-bit HS-DSCH CRC) successfully received during the test interval, divided by the duration of the test interval (in seconds).

F.6.3.2 Mapping throughput to block error ratio

- a) In measurement practice the UE indicates successfully received information bit payload by signalling an ACK to the SS.
If payload is received, but damaged and cannot be decoded, the UE signals a NACK.
- b) Only the ACK and NACK signals, not the data bits received, are accessible to the SS.
The number of bits is known in the SS from knowledge of what payload was sent.

- c) For fixed reference channel the number of bits in a TTI is fixed during one test.
- d) The time in the measurement interval is composed of successful TTIs (ACK), unsuccessful TTIs (NACK) and DTX-TTIs.
- e) DTX-TTIs occur regularly according to the H-set. (regDTX).
In real live this is the time when other UEs are served.
regDTX vary from test to test but are fixed within the test.
- f) Additional DTX-TTIs occur statistically when the UE is not responding ACK or NACK where it should.
(statDTX)
This may happen when the UE was not expecting data or decided that the data were not intended for it.

The pass / fail decision is done by observing the:

- number of NACKs
- number of ACKs and
- number of statDTXs (regDTX is implicitly known to the SS)

The ratio $(\text{NACK} + \text{statDTX}) / (\text{NACK} + \text{statDTX} + \text{ACK})$ is the Block Error Ratio BLER. Taking into account the time consumed by the ACK-, NACK-, and DTX-TTIs (regular and statistical), BLER can be mapped unambiguously to throughput for any single FRC test.

F.6.3.3 Bad DUT factor

Note: Data throughput in a communication system is of statistical nature and must be measured and decided pass or fail. The specified limit of throughput related to the ideal throughput in different throughput tests is in the range of a few % to near 100%. To make it comparable with BER, we define the complement of the relative throughput: BLER as defined above. Complementary this is in the range of near 100% down to a few % For e.g. BLER = 1%, the currently in BER BLER used Bad DUT factor M=1.5 is highly meaningful. For e.g. BLER = 99%, the currently used M=1.5 obviously meaningless.

An appropriate definition of the bad DUT factor is illustrated in figure F.6.3.3: constant and variable Bad DUT factor.

It illustrates how to find the Bad BLER when the nominal BLER is given.

- 1) In the range $0\% < \text{nominal BLER} > 10\%$ the Bad DUT factor is constant 1.5
- 2) In the range $90\% < \text{bad BLER} > 100\%$ it decreases to 1. (symmetrical to (1))
- 3) The range in between is interpolated by an arc section.

The example shows: nominal BLER=35,6% → bad BLER=47.67.5% → M=1.34

(blue mapping)

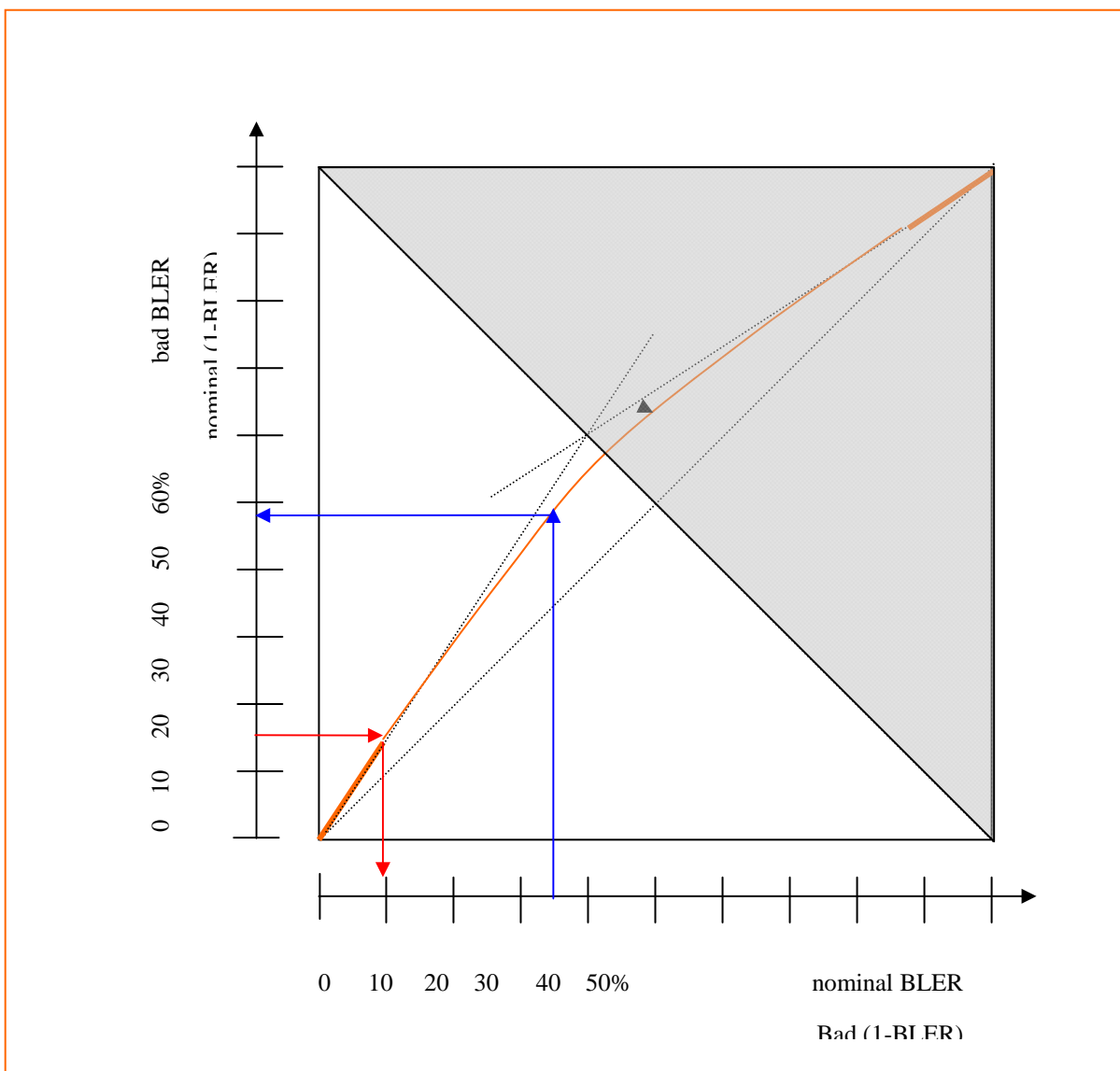

Figure F.6.3.3: constant and variable Bad DUT factor

Formula:

For $0 < \text{BLER} \leq 0.1$ $M = 1.5$

$$M(\text{BLER}) := \frac{\sqrt{r^2 - (\text{BLER} - 2.35)^2}}{\text{BLER}} - \frac{1.35}{\text{BLER}}$$

For $0.1 < \text{BLER} < 0.9$

For $0.9 \leq \text{BLER} < 1$ $M(\text{BLER}) = 2/3\text{BLER} + 1/3$

With BLER: nominal Block Error Ratio ($0 < \text{BLER} < 1$)

With $r = 2.70415$ (Radius of the arc)

F.6.3.3.1 Bad DUT factor, range of applicability

Inaccuracy is one practical reason to avoid the grey shaded area of figure F.6.3.3: constant and variable Bad DUT factor. For BLER near 1 the Bad DUT factor M is near 1. For $M=1$, exactly, the pass and fail criteria do not intersect. The test never is finalised.

For M near 1 the pass and fail criteria exhibit a very smooth intersection. In addition the binomial distribution and its inverse are of discrete nature. Therefore the test limit and the number of samples is calculable only very ambiguous.

It is proposed to apply the bad DUT factor only in the not shaded area of figure F.6.3.3.

This is done by the following:

BLER mode:

Use BLER as defined above in the range of 0 to 50%, use $M > 1$ as defined above.

The Test Limit will be $>$ the Test Requirement in the table F.6.3.5. below.

Relative Throughput mode:

If BLER is in the range 50 to 100%, use 1-BLER instead. Use $m < 1$ instead of M .

1-BLER is the relative throughput with respect to the ideal throughput.

As a consequence, the Test Limit $<$ Test Requirement

Formula for m :

For $0 < (1-\text{BLER}) \leq 0.15$ $m = 1/1.5$

$$m := \frac{2.35 - \sqrt{r^2 - [(1 - \text{BLER}) + 1.35]^2}}{(1 - \text{BLER})}$$

For $0.15 < (1-\text{BLER}) < 0.85$

In the figure F.6.3.3: this is represented by the red mapping.

The tables F.6.3.5. below distinguish between m and M .

F.6.3.4 Minimum Test time

Same as with BER BLER there is a minimum test time necessary for multipath fading profiles with the same justification:

Table F.6.3.5 Applicability and characteristics of the Tables F.6.3.5.1 to F.6.3.5.4.6

profile	Minimum Test time
PA3, PB3	164s
VA30	16.4s
VA 120	4.1s

The purpose of tables F.6.3.5.1 to F.6.3.5.4 is to decide throughput pass or fail.

(the Ior/Ioc levels are only for reference)

Meaning of a decision:

- A passed DUT is not worse than a Bad DUT with 95% confidence level.
- A failed DUT is not better than a Limit DUT with 95% confidence level.

The minimum Test Time is

- 1) the minimum test time due to statistical reasons

(To ensure the confidence level, the test must be continued until a certain number of samples (NACK+statDTX +ACK) is reached.)

- 2) the minimum test time due to multipath fading.

The longer test time applies. It is marked in table F.6.3.5. which one applies.

Statistical independence:

If a process works within an incremental redundancy sequence, the samples are not independent. The incremental redundancy sequence for every process must be finalised, successfully or unsuccessfully, on or beyond the minimum test time.

Then the BLER (or 1-BLER) is compared with the Test Limit to decide pass or fail.

Note: It is FFS, if correlation within groups of retransmissions may influence the confidence level of the test.

Formula:

The theory, to derive the minimum number of samples and the Test Limit, takes into consideration that BLER is in the range of near 0% to near 100%. Hence it is based on the binomial distribution and its inverse cumulative function: qbinom:

For the BLER test mode:

$$ne_{low}=qbinom(D,ns,M*BLER_{limit}) \quad (1)$$

$$ne_{high}=qbinom(1-D,ns,BLER_{limit}) \quad (2)$$

given: 1-D: confidence level= 95%

$BLER_{limit}$ =Block error ratio at the limit

M: Bad DUT factor >1

Input: ns: number of samples (NACK+ statDTX + ACK)

Output ne: number of events (NACK+ statDTX)

The intersection of (1) and (2) is the Test Limit with the coordinates: ns and ne

For the Relative Throughput test mode:

$$ne_{low}=qbinom(D,ns,1-BLER_{limit}) \quad (3)$$

$$ne_{high}=qbinom(1-D,ns,m*(1-BLER_{limit})) \quad (4)$$

given: 1-D: confidence level= 95%

$1-BLER_{limit}$ = Relative Throughput at the limit

m: Bad DUT factor <1

Input: ns: number of samples (NACK+ statDTX + ACK)

Output ne: number of events (ACK)

The intersection of (3) and (4) is the Test Limit with the coordinates: ns and ne

Note 1: In contrast to BER BLER test, this approach does not contain any test time optimisation. (early pass, early fail)

Note 2: The intersection of (3) and (4) above is a multipoint intersection due to the discrete nature of those curves. Thus, the specific intersection point used for the test limit is a subjective decision about the intersection point. In all cases, the intersection point was chosen such that it fell in the middle of the set of intersections of curves (3) and (4) above.

Nomenclature used in the tables F.6.3.5... below:

- NACK+ statDTX + ACK is summarised as No of samples
- NACK+ statDTX is summarised as No of errors
- ACK is summarised as No of successes

- In the BLER (BL) test mode the ratio: $\frac{\text{No of errors}}{\text{No of samples}}$ is recorded. In this mode a pass is below the test limit
- In the Relative Throughput (RT) test mode (1-BLER) the ratio: $\frac{\text{No of successes}}{\text{No of samples}}$ is recorded. In this mode a pass is above the test limit
- The test mode, used, is indicated in the rightmost column with BL or RT
- The transition from the BL to the RT test mode can also be seen in the column relative test requirement: BLER% \rightarrow (1-BLER%)
- The generic term for No of errors (BLER mode) or No of successes (Relative Throughput mode) is No of events. This is used in the table column Test Limit.

Table F.6.3.5.1 Maximum Input Level for HS-PDSCH Reception (16QAM)

Maximum Input Level for HS-PDSCH Reception (16QAM)	Absolute Test requirement (kbps)	Relative test requirement (normalized to ideal=777 kbps)	Test limit expressed as No of events/min No of samples (Bad DUT factor)	Min No of samples (number of events to pass)	Test time in s	BL / RT
16 QAM H-Set 1		No of events/No of samples in %		Mandatory if applicable	Mandatory if fading Informative and approx. if statistical	
	700	10%	58/467 (M=1.5)	467 (≤ 58)	2.8s (stat)	BL

Table F.6.3.5.2.1 Single link performance for test case 9.2.1A, 9.2.1C and 9.2.1F demodulation of HS-DSCH (QPSK, H-Set 1, 2, 3)

Single link Performance	H-SET 1 Absolute Test requirement (kbps)		Relative test requirement (normalized to ideal=534 kbps for H-SET 1)	Test limit expressed as No of events/min No of samples for H-SET 1, 2, 3	Min No of samples (number of events to pass)	Test time in s	BL / RT
QPSK H-Set 1/2/3			No of events/No of samples in % BL → (RT)	(Bad DUT factor)	Mandatory if applicable	Mandatory if fading Informative and approx. if statistical	
Test number							
1 ($\hat{I}_{or}/I_{oc} = 0$ dB)	PA3	65	87.82% → (12.18%)	60/595 (m = 1 / 1.5)	N.A.	164s (fading)	RT
2 ($\hat{I}_{or}/I_{oc} = 0$ dB)	PB3	23	95.69% → (4.31%)	64/1796 (m = 1/1.5)	N.A.	164s (fading)	RT
		138	74.14% → (25.86%)	58/268 (m = 0.682)	N.A.	164s(fading)	RT
3 ($\hat{I}_{or}/I_{oc} = 0$ dB)	VA30	22	95.9% → (4.1%)	64/1888 (m=1/1.5)	N.A.	16.4s(fading)	RT
		142	73.4% → (26.6%)	59/264 (m = 0.684)	N.A.	16.4s(fading)	RT
4 ($\hat{I}_{or}/I_{oc} = 0$ dB)	VA12 0	13	97.564% → (2.436%)	63/3224 (m = 1/1.5)	3224 (≥63)	H-set 1: 19.5s(stat) H-set 2: 13s (stat) H-set 3: 6.5s (stat)	RT
		140	73.77% → (26.23%)	59/268 (m = 0.683)	N.A.	4.1s(fading)	RT
1 ($\hat{I}_{or}/I_{oc} = 10$ dB)	PA3	309	42.1%	83/171 (M = 1.295)	N.A.	164s (fading)	BL
		423	20.74%	60/237 (M = 1.445)	N.A.	164s (fading)	BL
2 ($\hat{I}_{or}/I_{oc} = 10$ dB)	PB3	181	66.1% → (33.9%)	62/215 (m = 0.703)	N.A.	164s (fading)	RT
		287	46.22% → (53.78%)	84/176 (m = 0.77)	N.A.	164s(fading)	RT
3 ($\hat{I}_{or}/I_{oc} = 10$ dB)	VA30	190	64.4% → (35.6%)	64/211 (m = 0.708)	N.A.	16.4s(fading)	RT
		295	44.72% → (55.28%)	85/173 (m = 0.775)	N.A.	16.4s(fading)	RT
4 ($\hat{I}_{or}/I_{oc} = 10$ dB)	VA12 0	181	66.1% → (33.9%)	62/215 (m = 0.703)	N.A.	4.1s(fading)	RT
		275	48.5% → (51.5%)	79/174 (m = 0.761)	N.A.	4.1s(fading)	RT

Table F.6.3.5.2.1A Single link Performance for test case 9.2.1D and 9.2.1E demodulation of HS-DSCH (enhanced requirement type 1, QPSK, H-Set 1, 2, 3)

Single link enhanced requirement type 1 Performance	H-SET 1 Absolute Test requirement (kbps)		Relative test requirement (normalized to ideal=534 kbps for H-SET 1)	Test limit expressed as No of events/min No of samples for H-SET 1, 2, 3	Min No of samples (number of events to pass)	Test time in s	BL / RT
QPSK H-Set 1/2/3			No of events/No of samples in % BL → (RT)	(Bad DUT factor)	Mandatory if applicable	Mandatory if fading	Informative and approx. if statistical
Test number							
1 ($\hat{I}_{or}/I_{oc} = 0$ dB)	PA3	195	63.46% → (36.54%)	64/205 (m = 0.710)	N.A.	164s (fading)	RT
		329	38.35% → (61.65%)	78/175 (M = 1.320)	N.A.	164s (fading)	BL
2 ($\hat{I}_{or}/I_{oc} = 0$ dB)	PB3	156	70.77% → (29.23%)	59/239 (m = 0.690)	N.A.	164s (fading)	RT
		263	50.72% → (49.28%)	76/176 (m = 0.753)	N.A.	164s (fading)	RT
3 ($\hat{I}_{or}/I_{oc} = 0$ dB)	VA30	171	67.96% → (32.04%)	61/225 (m = 0.697)	N.A.	16.4s(fading)	RT
		273	48.84% → (51.16%)	96/174 (M = 1.252)	N.A.	16.4s(fading)	BL
4 ($\hat{I}_{or}/I_{oc} = 0$ dB)	VA120	168	68.52% → (34.48%)	60/228 (m = 0.696)	N.A.	4.1s(fading)	RT
		263	50.72% → (49.28%)	76/176 (m = 0.753)	N.A.	4.1s(fading)	RT
1 ($\hat{I}_{or}/I_{oc} = 10$ dB)	PA3	247	53.72% → (46.28%)	72/180 (m = 0.742)	N.A.	164s (fading)	RT
		379	28.95% → (71.02%)	66/193 (M = 1.386)	N.A.	164s (fading)	BL
2 ($\hat{I}_{or}/I_{oc} = 10$ dB)	PB3	195	63.46% → (36.54%)	63/204 (m = 0.710)	N.A.	164s (fading)	RT
		316	40.79% → (59.21%)	81/172 (M = 1.303)	N.A.	164s (fading)	BL
3 ($\hat{I}_{or}/I_{oc} = 10$ dB)	VA30	212	60.27% → (39.73%)	66/194 (m = 0.720)	N.A.	16.4s(fading)	RT
		329	38.35% → (61.65%)	78/175 (M = 1.320)	N.A.	16.4s(fading)	BL
4 ($\hat{I}_{or}/I_{oc} = 10$ dB)	VA120	191	64.21% → (35.79%)	63/208 (m = 0.708)	N.A.	4.1s(fading)	RT
		293	45.10% → (54.90%)	89/173 (M = 1.275)	N.A.	4.1s(fading)	BL

Table F.6.3.5.2.2 Single link performance for test case 9.2.1A and 9.2.1C demodulation of HS-DSCH (16 QAM, H-Set 1, 2, 3)

Single link Performance	H-SET 1 Absolute Test requirement (kbps)		Relative test requirement (normalized to ideal=777 kbps for H-SET 1)	Test limit expressed as No of events/min No of samples for H-SET 1, 2, 3	Min No of samples (number of events to pass)	Test time in s	BL / RT
16 QAM H-Set 1/2/3			No of events/No of samples in % BL → (RT)	(Bad DUT factor)	Mandatory if applicable	Mandatory if fading	
Test number						Informative and approx. if statistical	
1 ($\hat{I}_{or}/I_{oc} = 10$ dB)	PA3	198	74.53% → (25.47%)	58/272 (m=0.681)	N.A.	164s (fading)	RT
		368	52.66% → (47.34%)	74/179 (m=0.746)	N.A.	164s(fading)	RT
2 ($\hat{I}_{or}/I_{oc} = 10$ dB)	PB3	34	95.626% → (4.374%)	64/1770 (m=1/1.5)	N.A.	164s (fading)	RT
		219	71.83% → (28,17%)	58/240 (m=0.687)	N.A.	164s (fading)	RT
3 ($\hat{I}_{or}/I_{oc} = 10$ dB)	VA30	47	93.95% → (6.05%)	63/1259 (m=1/1.5)	N.A.	16.4s (fading)	RT
		214	72.47% → (27.53%)	59/255 (m=0.686)	N.A.	16.4s (fading)	RT
4 ($\hat{I}_{or}/I_{oc} = 10$ dB)	VA120	28	96.4% → (3.6%)	64/2150 (m=1/1.5)	2150 (≥64)	12.9s H-set1 8.6s H-set2 4.3s Hset3 (stat)	RT
		167	78.51% → (21.49%)	57/319 (m=0.673)	N.A.	4.1s (fading)	RT

Table F.6.3.5.2.2A Single link Performance for test case 9.2.1D and 9.2.1E demodulation of HS-DSCH (enhanced requirement type 1, 16 QAM, H-Set 1, 2, 3)

Single link enhanced requirement type 1 Performance	H-SET 1 Absolute Test requirement (kbps)		Relative test requirement (normalized to ideal=777 kbps for H-SET 1)	Test limit expressed as No of events/min No of samples for H-SET 1, 2, 3	Min No of samples (number of events to pass)	Test time in s	BL / RT
16 QAM H-Set 1/2/3			No of events/No of samples in % BL → (RT)	(Bad DUT factor)	Mandatory if applicable	Mandatory if fading	
Test number						Informative and approx. if statistical	
1 ($\hat{I}_{or}/I_{oc} = 10$ dB)	PA3	312	59.86% → (40.14%)	66/193 (m = 0.722)	N.A.	164s (fading)	RT
		487	37.35% → (62.65)	76/176 (M = 1.327)	N.A.	164s (fading)	BL
2 ($\hat{I}_{or}/I_{oc} = 10$ dB)	PB3	275	64.62% → (35.38%)	63/209 (m = 0.707)	N.A.	164s (fading)	RT
		408	47.51% → (52.49)	94/174 (M = 1.260)	N.A.	164s (fading)	BL
3 ($\hat{I}_{or}/I_{oc} = 10$ dB)	VA30	296	61.92% → (38.08%)	65/199 (m = 0.715)	N.A.	16.4s (fading)	RT
		430	44.68% → (55.32%)	88/173 (M = 1.278)	N.A.	16.4s (fading)	BL
4 ($\hat{I}_{or}/I_{oc} = 10$ dB)	VA120	271	65.14% → (34.86%)	62/211 (m = 0.705)	N.A.	4.1s (fading)	RT
		392	49.57% → (50.43%)	97/175	N.A.	4.1s (fading)	BL

Table F.6.3.5.2.3 Single link performance for test case 9.2.1B demodulation of HS-DSCH (QPSK H-Set 4)

Single link Performance	Absolute Test requirement (kbps)		Relative test requirement (normalized to ideal=534 kbps)	Test limit expressed as No of events/min No of samples	Min No of samples	Test time in s	BL / RT
QPSK H-Set 4			No of events/No of samples in % BL → (RT)	(Bad DUT factor)	(number of events to pass)	Mandatory if fading	
Test number					Mandatory if applicable	Informative and approx. if statistical	
1 ($\hat{I}_{or}/I_{oc} = 0$ dB)	PA3	72	86.5% → (13.5%)	59/528 (m=1/1.5)	N.A.	164s (fading)	RT
2 ($\hat{I}_{or}/I_{oc} = 0$ dB)		PB3	24	95.5% → (4.5%)	63/1695 (m=1/1.5)	N.A.	164s (fading)
			142	73.4% → (26.6%)	59/264 (m=0.684)	N.A.	164s (fading)
3 ($\hat{I}_{or}/I_{oc} = 0$ dB)	VA30	19	96.44% → (3.56%)	64/2176 (m=1/1.5)	N.A.	16.4s (fading)	RT
			148	72.27% → (27.73%)	59/253 (m=0.686)	N.A.	16.4s (fading)
4 ($\hat{I}_{or}/I_{oc} = 0$ dB)	VA120	11	98% → (2%)	65/3746 (m=1/1.5)	3746 (≥65)	22.5s (stat)	RT
			144	73% → (27%)	58/256 (m=0.684)	N.A.	4.1s (fading)
1 ($\hat{I}_{or}/I_{oc} = 10$ dB)	PA3	340	36.29%	75/177 (M=1.334)	N.A.	164s (fading)	BL
			439	17.74%	58/266 (M=1.468)	N.A.	164s (fading)
2 ($\hat{I}_{or}/I_{oc} = 10$ dB)	PB3	186	65.15% → (34.85%)	62/209 (m=0.705)	N.A.	164s (fading)	RT
			299	44% → (56%)	87/174 (m=0.778)	N.A.	164s(fading)
3 ($\hat{I}_{or}/I_{oc} = 10$ dB)	VA30	183	65.7% → (34.3%)	63/216 (m=0.704)	N.A.	16.4s (fading)	RT
			306	42.66%	86/176 (M=1.291)	N.A.	16.4s (faging)
4 ($\hat{I}_{or}/I_{oc} = 10$ dB)	VA120	170	68,14% → (31.86%)	61/226 (m=697)	N.A.	4.1s (fading)	RT
			284	46.78% → (53.22%)	81/172 (m = 0.767)	N.A.	4.1s (fading)

Table F.6.3.5.2.4 Single link performance for test case 9.2.1B demodulation of HS-DSCH (QPSK H-Set 5)

Single link Performance	Absolute Test requirement (kbps)		Relative test requirement (normalized to ideal=801 kbps)	Test limit expressed as No of events/min No of samples	Min No of samples (number of events to pass)	Test time in s	BL / RT
QPSK H-Set 5			No of events/No of samples in % BL → (RT)	(Bad DUT factor)	Mandatory if applicable	Mandatory if fading	
Test number						Informative and approx. if statistical	
1 ($\hat{I}_{or}/I_{oc} = 0$ dB)	PA3	98	87.76% → (12.24%)	59/583 (m=1/1.5)	N.A.	164s (fading)	RT
2 ($\hat{I}_{or}/I_{oc} = 0$ dB)		PB3	35	95.63% → (4.37%)	63/1746 (m=1/1.5)	N.A.	164s (fading)
			207	74.14% → (25.86%)	58/268 (m=0.682)	N.A.	164s (fading)
3 ($\hat{I}_{or}/I_{oc} = 0$ dB)	VA30	33	95.88% → (4.12%)	64/1879 (m=1/1.5)	N.A.	16.4s (fading)	RT
			213	73.4% → (26.6%)	59/2644 (m=0.684)	N.A.	16.2s (fading)
4 ($\hat{I}_{or}/I_{oc} = 0$ dB)	VA120	20	97.5% → (2.5%)	64/3101 (m=1/1.5)	3101 (≥64)	12.4s (stat)	RT
			210	73.77% → (26.23%)	59/268 (m=0.683)	N.A.	4.1s (fading)
1 ($\hat{I}_{or}/I_{oc} = 10$ dB)	PA3	464	42%	84/174 (M=1.295)	N.A.	164s (fading)	BL
			635	20.67%	59/234 (M=1.446)	N.A.	164s (fading)
2 ($\hat{I}_{or}/I_{oc} = 10$ dB)	PB3	272	66.02% → (33.98%)	63/218 (m=0.703)	N.A.	164s (fading)	RT
			431	46.16% → (53.84)	84/176 (m=0.77)	N.A.	164s(fading)
3 ($\hat{I}_{or}/I_{oc} = 10$ dB)	VA30	285	64.4% → (35.6%)	64/211 (m=0.708)	N.A.	16.4s (fading)	RT
			443	44.7% → (55.3%)	85/173 (m=0.775)	N.A.	16.4s(fading)
4 ($\hat{I}_{or}/I_{oc} = 10$ dB)	VA120	272	66.02% → (33.98%)	63/218 (m=0.703)	N.A.	4.1s (fading)	RT
			413	48.4% → (51.6%)	81/176 (m=0.761)	N.A.	4.1s(fading)

Table F.6.3.5.2.5 Single link Performance for test case 9.2.1C demodulation of HS-DSCH (QPSK H-Set 6)

Single link Performance	Absolute Test requirement (kbps)		Relative test requirement (normalized to ideal=3219 kbps)	Test limit expressed as No of events/min No of samples	Min No of samples (number of events to pass)	Test time in s	BL / RT
QPSK H-Set 6			No of events/No of samples in % BL → (RT)	(Bad DUT factor)	Mandatory if applicable	Mandatory if fading	
Test number						Informative and approx. if statistical	
1 ($\hat{I}_{or}/I_{oc} = 10$ dB)	PA3	1407	56.29% → (43.71%)	70/185	N.A.	164s (fading)	RT
			2090	35.07% → (64.93%)	73/179	N.A.	164s (fading)

Table F.6.3.5.2.5A Single link Performance for test case 9.2.1E demodulation of HS-DSCH (enhanced requirement type 1, QPSK H-Set 6)

Single link enhanced requirement type 1 Performance	Absolute Test requirement (kbps)		Relative test requirement (normalized to ideal=3219 kbps)	Test limit expressed as No of events/min No of samples	Min No of samples	Test time in s	BL / RT
QPSK H-Set 6			No of events/No of samples in % BL → (RT)	(Bad DUT factor)	(number of events to pass)	Mandatory if fading	
Test number					Mandatory if applicable	Informative and approx. if statistical	
1 ($\hat{I}_{or}/I_{oc} = 10$ dB)	PA3	672	79.12% → (20.88%)	57/328 (m = 0.672)	N.A.	164s (fading)	RT
		1305	59.46% → (40.54%)	67/193 (m = 0.723)	N.A.	164s (fading)	RT

Table F.6.3.5.2.5B Single link Performance for test case 9.2.1F demodulation of HS-DSCH (enhanced requirement type 2, QPSK H-Set 6)

Single link enhanced requirement type 2 Performance	Absolute Test requirement (kbps)		Relative test requirement (normalized to ideal=3219 kbps)	Test limit expressed as No of events/min No of samples	Min No of samples	Test time in s	BL / RT
QPSK H-Set 6			No of events/No of samples in % BL → (RT)	(Bad DUT factor)	(number of events to pass)	Mandatory if fading	
Test number					Mandatory if applicable	Informative and approx. if statistical	
1 ($\hat{I}_{or}/I_{oc} = 10$ dB)	PA3	1494	53.59% → (46.41%)	72/179 (m = 0.743)	N.A.	164s (fading)	RT
		2153	33.12% → (66.88%)	71/182 (M = 1.356)	N.A.	164s (fading)	BL
2 ($\hat{I}_{or}/I_{oc} = 10$ dB)	PB3	1038	67.75% → (32.25%)	61/224 (m = 0.698)	N.A.	164s (fading)	RT
		1744	45.82% → (54.18%)	90/172 (M = 1.271)	N.A.	164s (fading)	BL
3 ($\hat{I}_{or}/I_{oc} = 10$ dB)	VA30	1142	64.52% → (35.48%)	63/209 (m = 0.707)	N.A.	16.4s(fading)	RT
		1782	44.64% → (55.36%)	88/172 (M = 1.278)	N.A.	16.4s(fading)	BL
4 ($\hat{I}_{or}/I_{oc} = 10$ dB)	VA12 0	909	71.76% → (28.24%)	59/248 (m = 0.687)	N.A.	4.1s(fading)	RT
		1467	54.43% → (45.57%)	72/181 (m = 0.740)	N.A.	4.1s(fading)	RT

Table F.6.3.5.2.6 Single link Performance for test case 9.2.1C demodulation of HS-DSCH (16 QAM H-Set 6)

Single link Performance	Absolute Test requirement (kbps)		Relative test requirement (normalized to ideal=4689 kbps)	Test limit expressed as No of events/min No of samples	Min No of samples	Test time in s	BL / RT
16 QAM H-Set 6			No of events/No of samples in % BL → (RT)	(Bad DUT factor)	(number of events to pass)	Mandatory if fading	
Test number					Mandatory if applicable	Informative and approx. if statistical	
1 ($\hat{I}_{or}/I_{oc} = 10$ dB)	PA3	887	81.08% → (18.92%)	56/362 (m = 0.669)	N.A.	164s (fading)	RT
		1664	64.51% → (35.49%)	63/209 (m = 0.707)	N.A.	164s (fading)	RT

Table F.6.3.5.2.6A Single link Performance for test case 9.2.1E demodulation of HS-DSCH (enhanced requirement type 1, 16 QAM H-Set 6)

Single link enhanced requirement type 1 Performance	Absolute Test requirement (kbps)		Relative test requirement (normalized to ideal=4689 kbps)	Test limit expressed as No of events/min No of samples (Bad DUT factor)	Min No of samples (number of events to pass)	Test time in s Mandatory if fading Informative and approx. if statistical	BL / RT
16 QAM H-Set 6			No of events/No of samples in % BL → (RT)		Mandatory if applicable		
Test number							
1 ($\hat{I}_{or}/I_{oc} = 10$ dB)	PA3	912	80.55% → (19.45%)	56/352 (m = 0.670)	N.A.	164s (fading)	RT
		1730	63.10% → (36.90%)	64/203 (m = 0.712)	N.A.	164s (fading)	RT

Table F.6.3.5.2.6B Single link Performance for test case 9.2.1F demodulation of HS-DSCH (enhanced requirement type 2, 16 QAM H-Set 6)

Single link enhanced requirement type 2 Performance	Absolute Test requirement (kbps)		Relative test requirement (normalized to ideal=4689 kbps)	Test limit expressed as No of events/min No of samples (Bad DUT factor)	Min No of samples (number of events to pass)	Test time in s Mandatory if fading Informative and approx. if statistical	BL / RT
16 QAM H-Set 6			No of events/No of samples in % BL → (RT)		Mandatory if applicable		
Test number							
1 ($\hat{I}_{or}/I_{oc} = 10$ dB)	PA3	991	78.86% → (21.14%)	57/324 (m = 0.673)	N.A.	164s (fading)	RT
		1808	61.44% → (38.56%)	65/197 (m = 0.717)	N.A.	164s (fading)	RT
2 ($\hat{I}_{or}/I_{oc} = 10$ dB)	PB3	465	90.08% → (9.92%)	60/740 (m = 1/1.5)	N.A.	164s (fading)	RT
		1370	70.78% → (29.22%)	59/242 (m = 0.690)	N.A.	164s (fading)	RT
3 ($\hat{I}_{or}/I_{oc} = 10$ dB)	VA30	587	87.48% → (12.52%)	59/573 (m = 1/1.5)	N.A.	16.4s(fading)	RT
		1488	68.26% → (31.74%)	60/226 (m = 0.697)	N.A.	16.4s(fading)	RT
4 ($\hat{I}_{or}/I_{oc} = 10$ dB)	VA12 0	386	91.77% → (8.23%)	61/905 (m = 1/1.5)	N.A.	4.1s(fading)	RT
		1291	72.46% → (27.54%)	58/254	N.A.	4.1s(fading)	RT

Table F.6.3.5.3.1 Open Loop Diversity Performance for test case 9.2.2A and 9.2.2D demodulation of HS-DSCH (QPSK, H-Set 1, 2, 3)

Open Loop Diversity Performance	H-SET 1 Absolute Test requirement (kbps)		Relative test requirement (normalized to ideal=534 kbps for H-SET 1)	Test limit expressed as No of events/min No of samples for H-SET 1, 2, 3	Min No of samples (number of events to pass)	Test time in s	BL / RT
QPSK H-Set 1/2/3			No of events/No of samples in % BL → (RT)	(Bad DUT factor)	Mandatory if applicable	Mandatory if fading	Informative and approx. if statistical
Test number							
1 ($\hat{I}_{or}/I_{oc} = 0$ dB)	PA3	77	85.57% → (14.43%)	58/486 (m=1/1.5)	N.A.	164s (fading)	RT
		180	66.27% → (33.73%)	62/216 (m=0.702)	N.A.	164s (fading)	RT
2 ($\hat{I}_{or}/I_{oc} = 0$ dB)	PB3	20	96.25% → (3.75%)	64/2065 (m=1/1.5)	N.A.	164s (fading)	RT
		154	71.14% → (28,86%)	59/243 (m=0.689)	N.A.	164s (fading)	RT
3 ($\hat{I}_{or}/I_{oc} = 0$ dB)	VA30	15	97.19% → (2.81%)	64/2758 (m=1/1.5)	H-Set 1: 2758 (≥64)	H-Set 2,3: 16.4s (fading) H-Set 1: 16.6s(stat.)	RT
		162	69.64% → (30.36%)	60/235 (m=0.693)	N.A.	16.4s (fading)	RT
1 ($\hat{I}_{or}/I_{oc} = 10$ dB)	PA3	375	29.7%	68/192 (M=1.38)	N.A.	164s (fading)	BL
		475	11%	58/425 (M=1.499)	N.A.	164s (fading)	BL
2 ($\hat{I}_{or}/I_{oc} = 10$ dB)	PB3	183	65.7% → (34.3%)	63/216 (m=0.704)	N.A.	164s (fading)	RT
		274	48.7% → (51.3%)	80/177 (m=0.76)	N.A.	164s (fading)	RT
3 ($\hat{I}_{or}/I_{oc} = 10$ dB)	VA30	187	65% → (35%)	62/208 (m=0.706)	N.A.	16.4s (fading)	RT
		284	46.8% → (53.2%)	82/174 (m=0.767)	N.A.	16.4s (fading)	RT

Table F.6.3.5.3.2 Open Loop Diversity Performance for test case 9.2.2A and 9.2.2D demodulation of HS-DSCH (16 QAM, H-Set 1, 2, 3)

Open Loop Diversity Performance	H-SET 1 Absolute Test requirement (kbps)		Relative test requirement (normalized to ideal=777 kbps for H-SET 1)	Test limit expressed as No of events/min No of samples for H-SET 1, 2, 3	Min No of samples (number of events to pass)	Test time in s	BL / RT
16 QAM H-Set 1/2/3			No of events/No of samples in % BL → (RT)	(Bad DUT factor)	Mandatory if applicable	Mandatory if fading	Informative and approx. if statistical
Test number							
1 ($\hat{I}_{or}/I_{oc} = 10$ dB)	PA3	295	62% → (38%)	66/203 (m=0.715)	N.A.	164s (fading)	RT
		463	40.4%	82/176 (M=1.306)	N.A.	164s (fading)	BL
2 ($\hat{I}_{or}/I_{oc} = 10$ dB)	PB3	24	96.9% → (3.1%)	64/2500 (m=1/1.5)	N.A.	164s (fading)	RT
		243	68.7% → (31.3%)	60/227 (m=0.695)	N.A.	164s (fading)	RT
3 ($\hat{I}_{or}/I_{oc} = 10$ dB)	VA30	35	95.5% → (4.5%)	63/1695 (m=1/1.5)	N.A.	16.4s (fading)	RT
		251	67.7% → (32.3%)	61/223 (m=0.698)	N.A.	16.4s (fading)	RT

Table F.6.3.5.3.3 Open Loop Diversity Performance for test case 9.2.2B demodulation of HS-DSCH (QPSK, H-Set 4)

Open Loop Diversity Performance	Absolute Test requirement (kbps)		Relative test requirement (normalized to ideal=534 kbps)	Test limit expressed as No of events/min No of samples	Min No of samples	Test time in s	BL / RT
QPSK H-Set 4			No of events/No of samples in % BL → (RT)	(Bad DUT factor)	(number of events to pass)	Mandatory if fading	
Test number					Mandatory if applicable	Informative and approx. if statistical	
1 ($\hat{I}_{or}/I_{oc} = 0$ dB)	PA3	70	86.9% →(13.1%)	59/544 (m=1/1.5)	N.A.	164s (fading)	RT
		171	68% →(32%)	61/225 (m=0.697)	N.A.	164s (fading)	RT
2 ($\hat{I}_{or}/I_{oc} = 0$ dB)	PB3	14	97.4% →(2.6%)	64/2982 (m=1/1.5)	N.A.	164s (fading)	RT
		150	71.9% →(28.1%)	59/250 (m=0.687)	N.A.	164s (fading)	RT
3 ($\hat{I}_{or}/I_{oc} = 0$ dB)	VA30	11	97.04% →(2.06%)	65/3819 (m=1/1.5)	3819 (≥65)	23s (stat)	RT
		156	70.8% →(29.2%)	60/243 (m=0.69)	N.A.	16.4s (fading)	RT
1 ($\hat{I}_{or}/I_{oc} = 10$ dB)	PA3	369	30.9%	69/188 (M=1.372)	N.A.	164s (fading)	BL
		471	11.7%	58/400 (M=1.497)	N.A.	164s (fading)	BL
2 ($\hat{I}_{or}/I_{oc} = 10$ dB)	PB3	180	66.3% →(33.7%)	63/220 (m=0.702)	N.A.	164s (fading)	RT
		276	48.3% →(51.7%)	79/173 (m=0.762)	N.A.	164s (fading)	RT
3 ($\hat{I}_{or}/I_{oc} = 10$ dB)	VA30	184	65.5% →(34.5%)	62/211 (m=0.704)	N.A.	16.4s (fading)	RT
		285	46.6% →(53.4%)	81/171 (m=0.768)	N.A.	16.4s (fading)	RT

Table F.6.3.5.3.4 Open Loop Diversity Performance for test case 9.2.2B demodulation of HS-DSCH (QPSK, H-Set 5)

Open Loop Diversity Performance QPSK H-Set 5	Absolute Test requirement (kbps)		Relative test requirement, normalized to ideal=801 kbps	Test limit expressed as No of events/min No of samples	Min No of samples	Test time in s	BL / RT
			No of events/No of samples in % BL → (RT)	(Bad DUT factor)	(number of events to pass)	Mandatory if fading	
Test number					Mandatory if applicable	Informative and approx. if statistical	
1 ($\hat{I}_{or}/I_{oc} = 0$ dB)	PA3	116	85.5% →(14.5%)	59/492 (m=0.667)	N.A.	164s (fading)	RT
		270	66.27% →(33.73%)	62/216 (m=0.702)	N.A.	164s (fading)	RT
2 ($\hat{I}_{or}/I_{oc} = 0$ dB)	PB3	30	96.25% →(3.75%)	65/2100 (m=1/1.5)	N.A.	164s (fading)	RT
		231	71.14% →(28.86%)	58/243 (m=0.689)	N.A.	164s (fading)	RT
3 ($\hat{I}_{or}/I_{oc} = 0$ dB)	VA30	23	97.13% →(2.87%)	64/2741 (m=1/1.5)	N.A.	16.4s (fading)	RT
		243	69.64% →(30.36%)	60/234 (m=0.693)	N.A.	16.4s (fading)	RT
1 ($\hat{I}_{or}/I_{oc} = 10$ dB)	PA3	563	29.67%	68/194 (M=1.381)	N.A.	164s (fading)	BL
		713	10.93%	58/428 (M=1.499)	N.A.	164s (fading)	BL
2 ($\hat{I}_{or}/I_{oc} = 10$ dB)	PB3	275	65.65% →(34.35%)	64/212 (m=0.704)	N.A.	164s (fading)	RT
		411	48.66% →(51.34%)	77/170 (m=0.76)	N.A.	164s (fading)	RT
3 ($\hat{I}_{or}/I_{oc} = 10$ dB)	VA30	281	64.9% →(35.1%)	63/211 (m=0.706)	N.A.	16.4s (fading)	RT
		426	46.78% →(53.22%)	81/172 (m=0.767)	N.A.	16.4s (fading)	RT

Table F.6.3.5.3.5 Open Loop Diversity Performance for test case 9.2.2C demodulation of HS-DSCH (QPSK, H-Set 1, 2, 3)

Open Loop Diversity Performance	H-SET 1 Absolute Test requirement (kbps)		Relative test requirement (normalized to ideal=534 kbps for H-SET 1)	Test limit expressed as No of events/min No of samples for H-SET 1, 2, 3	Min No of samples (number of events to pass)	Test time in s	BL / RT
QPSK H-Set 1/2/3			No of events/No of samples in % BL → (RT)	(Bad DUT factor)	Mandatory if applicable	Mandatory if fading	Informative and approx. if statistical
Test number							
1 ($\hat{I}_{or}/I_{oc} = 0$ dB)	PA3	197	63.09% → (36.91%)	64/203 (m = 0.712)	N.A.	164s (fading)	RT
		330	38.16% → (61.84%)	80/181 (M = 1.321)	N.A.	164s (fading)	BL
2 ($\hat{I}_{or}/I_{oc} = 0$ dB)	PB3	152	71.52% → (28.48%)	59/247 (m = 0.688)	N.A.	164s (fading)	RT
		251	52.97% → (47.03%)	73/179 (m = 0.745)	N.A.	164s (fading)	RT
3 ($\hat{I}_{or}/I_{oc} = 0$ dB)	VA30	164	69.27% → (30.73%)	60/232 (m = 0.694)	N.A.	16.4s (fading)	RT
		261	51.09% → (48.91%)	75/176 (m = 0.751)	N.A.	16.4s (fading)	RT
1 ($\hat{I}_{or}/I_{oc} = 10$ dB)	PA3	268	49.78% → (50.22%)	101/181 (M = 1.246)	N.A.	164s (fading)	BL
		407	23.74% → (76.26%)	62/217 (M = 1.424)	N.A.	164s (fading)	BL
2 ($\hat{I}_{or}/I_{oc} = 10$ dB)	PB3	183	65.71% → (34.29%)	62/213 (m = 0.704)	N.A.	164s (fading)	RT
		288	46.03% → (53.97%)	93/178 (M = 1.269)	N.A.	164s (fading)	BL
3 ($\hat{I}_{or}/I_{oc} = 10$ dB)	VA30	197	63.09% → (36.91%)	64/203 (m = 0.712)	N.A.	16.4s (fading)	RT
		307	42.47% → (57.53%)	87/178 (M = 1.292)	N.A.	16.4s (fading)	BL

Table F.6.3.5.3.6 Open Loop Diversity Performance for test case 9.2.2C demodulation of HS-DSCH (16QAM, H-Set 1, 2, 3)

Open Loop Diversity Performance	H-SET 1 Absolute Test requirement (kbps)		Relative test requirement (normalized to ideal=777 kbps for H-SET 1)	Test limit expressed as No of events/min No of samples for H-SET 1, 2, 3	Min No of samples (number of events to pass)	Test time in s	BL / RT
16 QAM H-Set 1/2/3			No of events/No of samples in % BL → (RT)	(Bad DUT factor)	Mandatory if applicable	Mandatory if fading	Informative and approx. if statistical
Test number							
1 ($\hat{I}_{or}/I_{oc} = 10$ dB)	PA3	340	56.26% → (43.74%)	70/184 (m = 0.733)	N.A.	16.4s (fading)	RT
		513	34.01% → (65.99%)	72/180 (M = 1.350)	N.A.	16.4s (fading)	BL
2 ($\hat{I}_{or}/I_{oc} = 10$ dB)	PB3	251	67.71% → (32.29%)	60/222 (m = 0.698)	N.A.	16.4s (fading)	RT
		374	51.89% → (48.11%)	74/177 (m = 0.749)	N.A.	16.4s (fading)	RT
3 ($\hat{I}_{or}/I_{oc} = 10$ dB)	VA30	280	63.98% → (36.02%)	63/206 (m = 0.709)	N.A.	16.4s (fading)	RT
		398	48.80% → (51.20%)	96/174 (M = 1.252)	N.A.	16.4s (fading)	BL

Table F.6.3.5.4.1 Closed Loop Diversity Performance for test case 9.2.3A, 9.2.3C and 9.2.3D demodulation of HS-DSCH (QPSK, H-Set 1, 2, 3)

Closed Loop Diversity Performance	H-SET 1 Absolute Test requirement (kbps)		Relative test requirement (normalized to ideal=534 kbps for H-SET 1)	Test limit expressed as No of events/min No of samples for H-SET 1, 2, 3	Min No of samples (number of events to pass)	Test time in s	BL / RT
QPSK H-Set 1/2/3			No of events/No of samples in % BL → (RT)	(Bad DUT factor)	Mandatory if applicable	Mandatory if fading	Informative and approx. if statistical
Test number							
1 ($\hat{I}_{or}/I_{oc} = 0$ dB)	PA3	118	77.89% →(22.11%)	58/315 (m=0.674)	N.A.	164s (fading)	RT
		225	57.84% →(42.16%)	69/189(m=0.728)	N.A.	164s (fading)	RT
2 ($\hat{I}_{or}/I_{oc} = 0$ dB)	PB3	50	90.63% →(9.37%)	61/787 (m=1/1.5)	N.A.	164s (fading)	RT
		173	67.58% →(32.42%)	61/222 (m=0.698)	N.A.	164s (fading)	RT
3 ($\hat{I}_{or}/I_{oc} = 0$ dB)	VA30	47	91.2% →(8.8%)	62/852 (m=1/1.5)	N.A.	16.4s (fading)	RT
		172	67.77% →(32.23%)	61/223 (m=0.698)	N.A.	16.4s (fading)	RT
1 ($\hat{I}_{or}/I_{oc} = 10$ dB)	PA3	399	25.23%	63/207 (M=1.413)	N.A.	164s (fading)	BL
		458	14.18%	57/325 (M=1.487)	N.A.	164s (fading)	BL
2 ($\hat{I}_{or}/I_{oc} = 10$ dB)	PB3	199	62.71% →(37.29%)	65/204 (m=0.713)	N.A.	164s (fading)	RT
		301	43.6%	88/180 (M=1.285)	N.A.	164s (fading)	BL
3 ($\hat{I}_{or}/I_{oc} = 10$ dB)	VA30	204	61.77% →(38.23%)	65/198 (m=0.716)	N.A.	16.4s (fading)	RT
		305	42.85%	85/173 (M=1.29)	N.A.	16.4s (fading)	BL

Table F.6.3.5.4.2 Closed Loop Diversity Performance for test case 9.2.3A, 9.2.3C and 9.2.3D demodulation of HS-DSCH (16 QAM, H-Set 1, 2, 3)

Closed Loop Diversity Performance	H-SET 1 Absolute Test requirement (kbps)		Relative test requirement (normalized to ideal=777 kbps for H-SET 1)	Test limit expressed as No of events/min No of samples for H-SET 1, 2, 3	Min No of samples (number of events to pass)	Test time in s	BL / RT
16 QAM H-Set 1/2/3			No of events/No of samples in % BL → (RT)	(Bad DUT factor)	Mandatory if applicable	Mandatory if fading	Informative and approx. if statistical
Test number							
1 ($\hat{I}_{or}/I_{oc} = 10$ dB)	PA3	361	53.56% →(46.44%)	73/180 (m=0.743)	N.A.	164s (fading)	RT
		500	35.68%	74/177 (M=1.338)	N.A.	164s (fading)	BL
2 ($\hat{I}_{or}/I_{oc} = 10$ dB)	PB3	74	90.48% →(9.52%)	62/788 (m=1/1.5)	N.A.	164s (fading)	RT
		255	67.2% →(32.8%)	61/219 (m=0.7)	N.A.	164s (fading)	RT
3 ($\hat{I}_{or}/I_{oc} = 10$ dB)	VA30	84	89.2% →(10.8%)	61/683 (m=1/1.5)	N.A.	16.4s (fading)	RT
		254	67.32% →(32.68%)	61/220 (m=0.699)	N.A.	16.4s (fading)	RT

Table F.6.3.5.4.3 Closed Loop Diversity Performance for test case 9.2.3B demodulation of HS-DSCH (QPSK, H-Set 4)

Closed Loop Diversity Performance QPSK H-Set 4	Absolute Test requirement (kbps)		Relative test requirement (normalized to ideal=534 kbps)	Test limit expressed as No of events/min No of samples	Min No of samples	Test time in s	BL / RT
			No of events/No of samples in % BL → (RT)	(Bad DUT factor)	(number of events to pass)	Mandatory if fading	
Test number					Mandatory if applicable	Informative and approx. if statistical	
1 ($\hat{I}_{or}/I_{oc} = 0$ dB)	PA3	114	78.64% →(21.36%)	58/327 (m=0.673)	N.A.	164s (fading)	RT
		223	58.21% →(41.79%)	69/191 (m=0.727)	N.A.	164s (fading)	RT
2 ($\hat{I}_{or}/I_{oc} = 0$ dB)	PB3	43	91.94% →(8.06%)	62/930 (m=1/1.5)	N.A.	164s (fading)	RT
		167	68.71% →(31.29%)	60/227 (m=0.695)	N.A.	164s (fading)	RT
3 ($\hat{I}_{or}/I_{oc} = 0$ dB)	VA30	40	92.5% →(7.5%)	63/1017 (m=1/1.5)	N.A.	16.4s (fading)	RT
		170	68.14% →(31.86%)	61/226 (m=0.697)	N.A.	16.4s (fading)	RT
1 ($\hat{I}_{or}/I_{oc} = 10$ dB)	PA3	398	25.42%	63/206 (M=1.412)	N.A.	164s (fading)	BL
		457	14.37%	57/321 (M=1.486)	N.A.	164s (fading)	BL
2 ($\hat{I}_{or}/I_{oc} = 10$ dB)	PB3	196	63.27 →(36.73%)	64/204 (m=0.711)	N.A.	164s (fading)	RT
		292	45.28% →(54.72%)	85/175 (m=0.773)	N.A.	164s (fading)	RT
3 ($\hat{I}_{or}/I_{oc} = 10$ dB)	VA30	199	62.71% →(37.29%)	65/204 (m=0.713)	N.A.	16.4s (fading)	RT
		305	42.85%	85/173 (M=1.29)	N.A.	16.4s (fading)	BL

Table F.6.3.5.4.4 Closed Loop Diversity Performance for test case 9.2.3B demodulation of HS-DSCH (QPSK, H-Set 5)

Closed Loop Diversity Performance	Absolute Test requirement (kbps)		Relative test requirement (normalized to ideal=801 kbps)	Test limit expressed as No of events/min No of samples	Min No of samples	Test time in s	BL / RT
QPSK H-Set 5			No of events/No of samples in % BL → (RT)	(Bad DUT factor)	(number of events to pass)	Mandatory if fading	
Test number					Mandatory if applicable	Informative and approx. if statistical	
1 ($\hat{I}_{or}/I_{oc} = 0$ dB)	PA3	177	77.89% →(22.11%)	58/315 (m=0.674)	N.A.	164s (fading)	RT
		338	57.78% →(42.22%)	68/186 (m=0.728)	N.A.	164s (fading)	RT
2 ($\hat{I}_{or}/I_{oc} = 0$ dB)	PB3	75	90.63% →(9.37%)	61/787 (m=1/1.5)	N.A.	164s (fading)	RT
		260	67.52% →(32.48%)	62/225 (m=0.699)	N.A.	164s (fading)	RT
3 ($\hat{I}_{or}/I_{oc} = 0$ dB)	VA30	71	91.13% →(8.87%)	62/846 (m=1/1.5)	N.A.	16.4s (fading)	RT
		258	67.77% →(32.23%)	61/223 (m=0.698)	N.A.	16.4s (fading)	RT
1 ($\hat{I}_{or}/I_{oc} = 10$ dB)	PA3	599	25.17%	64/211 (M=1.413)	N.A.	164s (fading)	BL
		687	14.18%	57/325 (M=1.487)	N.A.	164s (fading)	BL
2 ($\hat{I}_{or}/I_{oc} = 10$ dB)	PB3	299	62.65% →(37.35%)	64/200 (m=0.713)	N.A.	164s (fading)	RT
		452	43.54%	87/174 (M=1.285)	N.A.	164s (fading)	BL
3 ($\hat{I}_{or}/I_{oc} = 10$ dB)	VA30	306	61.77% →(38.23%)	65/198 (m=0.716)	N.A.	16.4s (fading)	RT
		458	42.79%	86/175 (M=1.29)	N.A.	16.4s (fading)	BL

Table F.6.3.5.4.5 Closed Loop Diversity Performance for test case 9.2.3D demodulation of HS-DSCH (QPSK, H-Set 6)

Closed Loop Diversity Performance	Absolute Test requirement (kbps)		Relative test requirement (normalized to ideal=3219 kbps)	Test limit expressed as No of events/min No of samples	Min No of samples	Test time in s	BL / RT
QPSK H-Set 6			No of events/No of samples in % BL → (RT)	(Bad DUT factor)	(number of events to pass)	Mandatory if fading	
Test number					Mandatory if applicable	Informative and approx. if statistical	
1 ($\hat{I}_{or}/I_{oc} = 10$ dB)	PB3	1536	52.28% → (47.72%)	74/178 (m = 0.747)	N.A.	164s (fading)	RT

Table F.6.3.5.4.6 Closed Loop Diversity Performance for test case 9.2.3D demodulation of HS-DSCH (16QAM, H-Set 6)

Closed Loop Diversity Performance	Absolute Test requirement (kbps)		Relative test requirement (normalized to ideal=4689 kbps)	Test limit expressed as No of events/min No of samples	Min No of samples	Test time in s	BL / RT
16QAM H-Set 6			No of events/No of samples in % BL → (RT)	(Bad DUT factor)	(number of events to pass)	Mandatory if fading	
Test number					Mandatory if applicable	Informative and approx. if statistical	
1 ($\hat{I}_{or}/I_{oc} = 10$ dB)	PB3	1154	75.39% → (24.61%)	57/280 (m = 0.679)	N.A.	164s (fading)	RT

F.5.7 Performance measurements (MBMS)

Table F.5.7.1: Equipment accuracy for performance measurements (MBMS)

Clause	Equipment accuracy	Test conditions
11.3 Demodulation of MTCH and cell identification	S-CCPCH_Ec/Ior ±0.1 dB	

F.6.4 Statistical testing of performance requirement (E-DCH)

F.6.4.1 Test Method

Each test is performed in the following manner:

- Setup the required test conditions.
- Measure the E-HICH, the E-RGCH and the E-AGCH repeated times. The results, measured, are summarized to:
 - a bad result, if the measured E-HICH returns a missed ACK or a false ACK or if the E_RGCH test returns a missed HOLD or a missed UP/DOWN or a missed DOWN or if the E-AGCH test returns a missed detection in the relevant test.
 - a good result, otherwise.
- Record the number of valid results (ns), tested, and the number of bad results (ne)
- Stop the test at an early pass or an early fail event.
- Once the test is stopped, decide according to the pass fail decision rules

F.6.4.2 Bad Result Ratio (ER)

The Bad Result Ratio (ER) is defined as the ratio of bad results (ne) to all valid results (ns).

(1-ER is the success ratio)

F.6.4.3 Mapping of E-DCH tests to RRM tests (F.6.2) and HSDPA tests (F.6.3)

The test design and the explanations for the RRM tests in F.6.2.4 to F.6.2.7 are valid also for the E-DCH test as long as the error ratio for minimum requirements is ≤ 0.1 .

The test design and the explanations for the HSDPA tests in F.6.3.3 to F.6.3.4 are partly valid also for the E-DCH test as long as the error ratio for minimum requirements is > 0.1 .

F.6.4.4 Test conditions for E-DCH tests

Table F.6.4.4: Test conditions for a E-DCH tests

Type of test	Minimum requirement (ER)	Test limit TL (ER)= Minimum requirement (ER)x TL TL	Target number of bad results	Prob that good unit will fail = Prob that bad unit will pass [%]	Bad unit factor M	Minimum Test time [s] Note 1
Detection of E-DCH HARQ ACK Indicator Channel (E-HICH)						
10.2.1.1 Single link performance (10ms TTI)						
Missed ACK probability (VA30, Test 1)	0.01	1.236	154	5	1.5	16.4
False ACK probability (VA30, Test 2)Note 2)	0.5	1.127	NA	5	1.245	16.4
10.2.1.2 Single link performance (2ms TTI)						
Missed ACK probability (VA30, Test 1)	0.01	1.236	154	5	1.5	16.4
False ACK probability (VA30, Test 2)Note 2)	0.5	1.127	NA	5	1.245	16.4
Detection in Inter-Cell Handover conditions						
10.2.2.1.1 RLS not containing the Serving E-DCH cell (10ms TTI).						
Missed ACK probability (VA30, Test1)	0.05	1.236	154	5	1.5	16.4
False ACK probability (VA30, Test 2)	2E-4	1.236	154	5	1.5	NA
10.2.2.1.2 RLS not containing the Serving E-DCH cell (2ms TTI)						
Missed ACK probability (VA30, Test 1)	0.05	1.236	154	5	1.5	16.4
False ACK probability (VA30, Test 2)	2E-4	1.236	154	5	1.5	NA
10.2.2.2.1 RLS containing the Serving E-DCH cell (10ms TTI)						
Missed ACK probability (Test 1, VA30)	0.05	1.236	154	5	1.5	16.4
False ACK probability (Test 2, PA3)	0.1	1.236	154	5	1.5	164s
False ACK probability (Test 3, VA120)	0.1	1.236	154	5	1.5	4.1
10.2.2.2.2 RLS containing the Serving E-DCH cell (2ms TTI)						
Missed ACK probability (Test 1, VA30)	0.05	1.236	154	5	1.5	16.4
False ACK probability (Test 2, PA3)	0.1	1.236	154	5	1.5	164
False ACK probability (Test 3, VA120)	0.1	1.236	154	5	1.5	4.1
Detection of E-DCH Relative Grant Channel (E-RGCH)						
10.3.1.1 Single link performance (10ms TTI)						
Missed UP/DOWN (VA30, Test 1)	0.05	1.236	154	5	1.5	16.4
Missed HOLD (VA30, Test 2)	0.1	1.236	154	5	1.5	16.4
10.3.1.2 Single link performance (2ms TTI)						
Missed UP/DOWN (VA30, Test 1)	0.05	1.236	154	5	1.5	16.4
Missed HOLD (VA30, Test 2)	0.1	1.236	154	5	1.5	16.4
10.3.2 Detection in Inter-Cell Handover conditions						
Missed HOLD probability (Test 1)	0.005	1.236	154	5	1.5	16.4
Missed DOWN probability (Test 2)	0.05	1.236	154	5	1.5	16.4
10.4 Demodulation of E-DCH Absolute Grant Channel (E-AGCH)						
Missed detection probability (Test 1)	0.01	1.236	154	5	1.5	16.4
Note 1)	The minimum test time due to propagation conditions is constant and overrides the test time due to statistical reasons. The test time due to statistical reasons is variable and depends on the quality of the DUT. Justification is given in clause F.6.1.6.					
Note 2)	No early decision is designed in this test. Sample for 16.4 s. Then decide the ER against the TL. The limit ratio is 102/181=0.563536					

Annex G (normative): Environmental conditions

G.1 General

This normative annex specifies the environmental requirements of the UE. Within these limits the requirements of the present documents shall be fulfilled.

G.2 Environmental requirements

The requirements in this clause apply to all types of UE(s)

G.2.1 Temperature

The UE shall fulfil all the requirements in the full temperature range of:

Table G.2.1.1

+15°C to + 35°C	for normal conditions (with relative humidity of 25 % to 75 %)
-10°C to + 55°C	for extreme conditions (see IEC publications 68-2-1 and 68-2-2)

Outside this temperature range the UE, if powered on, shall not make ineffective use of the radio frequency spectrum. In no case shall the UE exceed the transmitted levels as defined in TS 25.101 [1] for extreme operation.

Some tests in the present document are performed also in extreme temperature conditions. These test conditions are denoted as TL (temperature low, -10°C) and TH (temperature high, +55°C).

G.2.2 Voltage

The UE shall fulfil all the requirements in the full voltage range, i.e. the voltage range between the extreme voltages.

The manufacturer shall declare the lower and higher extreme voltages and the approximate shutdown voltage. For the equipment that can be operated from one or more of the power sources listed below, the lower extreme voltage shall not be higher, and the higher extreme voltage shall not be lower than that specified below.

Table G.2.2.1

Power source	Lower extreme voltage	Higher extreme voltage	Normal conditions voltage
AC mains	0.9 * nominal	1.1 * nominal	nominal
Regulated lead acid battery	0.9 * nominal	1.3 * nominal	1.1 * nominal
Non regulated batteries: - Leclanché / lithium - Mercury/nickel & cadmium	0.85 * nominal 0.90 * nominal	Nominal Nominal	Nominal Nominal

Outside this voltage range the UE if powered on, shall not make ineffective use of the radio frequency spectrum. In no case shall the UE exceed the transmitted levels as defined in TS 25.101 [1] for extreme operation. In particular, the UE shall inhibit all RF transmissions when the power supply voltage is below the manufacturer declared shutdown voltage.

Some tests in the present document are performed also in extreme voltage conditions. These test conditions are denoted as VL (lower extreme voltage) and VH (higher extreme voltage).

G.2.3 Vibration

The UE shall fulfil all the requirements when vibrated at the following frequency/amplitudes:

Table G.2.3.1

Frequency	ASD (Acceleration Spectral Density) random vibration
5 Hz to 20 Hz	0.96 m ² /s ³
20 Hz to 500 Hz	0.96 m ² /s ³ at 20 Hz, thereafter -3 dB / Octave

Outside the specified frequency range the UE, if powered on, shall not make ineffective use of the radio frequency spectrum. In no case shall the UE exceed the transmitted levels as defined in TS 25.101 [1] for extreme operation.

G.2.4 Specified frequency range

The manufacturer shall declare, which of the frequency bands defined in clause 4.2 is supported by the UE.

Some tests in the present document are performed also in low, mid and high range of the operating frequency band of the UE. The UARFCN's to be used for low, mid and high range are defined in TS 34.108 [3] clause 5.1.1.

For GSM frequency bands see TS 51.010-1 [25]. The test frequencies depend on the GSM bands supported by the terminal (according to PICS/PIXIT).

Annex H (normative): UE Capabilities (FDD)

For UE capabilities regarding FDD refer to TS 25.306.

H.1 Void

H.2 Void

Annex I (normative): Default Message Contents

This Annex contains the default values of common messages, other than those described in TS 34.108 [3]. The messages are primarily concerning the RRM test cases in clause 8 and unless indicated otherwise in specific test cases, shall be transmitted and checked by the system simulator. In this Annex, decimal values are normally used. However, sometimes, a hexadecimal value, indicated by an "H", or a binary value, indicated by a "B" is used.

Contents of MEASUREMENT REPORT message for Intra frequency test cases

Information Element	Value/remark	Version
Message Type Integrity check info	<p>The presence of this IE is dependent on IXIT statements in TS 34.123-2. If integrity protection is indicated to be active, this IE shall be present with the values of the sub IEs as stated below. Else, this IE and the sub-IEs shall be absent. This IE is checked to see if it is present. The value is compared against the XMAC-I value computed by SS.</p> <p>This IE is checked to see if it is present. The value is used by SS to compute the XMAC-I value.</p>	
- Message authentication code	1	
- RRC Message sequence number	1	
Measurement identity		
Measured Results		
- Intra-frequency measured results list		
- Cell measured results		
- Cell Identity	Not present	
- Cell synchronisation information		
- Tm		
- OFF	<p>If reporting of "Tm" measurement is configured then check that this IE is present. If reporting of "Tm" measurement is not configured then no check is needed.</p> <p>If reporting of "OFF" measurement is configured then check that this IE is present. If reporting of "OFF" measurement is not configured then no check is needed.</p>	
- CHOICE mode	FDD	
- Primary CPICH info	Checked that this IE is present	
- Primary scrambling code	See Annex K and TS 34.108 [3] section 6.1.4	
- CPICH Ec/N0	If reporting of "CPICH Ec/N0" measurement is configured then check that this IE is present. If reporting of "CPICH Ec/N0" measurement is not configured then no check is needed.	
- CPICH RSCP	If reporting of "CPICH RSCP" measurement is configured then check that this IE is present. If reporting of "CPICH RSCP" measurement is not configured then no check is needed.	
- Delta _{CPICH RSCP}	If reporting of "CPICH RSCP" measurement is configured this IE may be present	Rel-5
- Pathloss	This IE does not need to be checked.	
Measured results on RACH	If reporting of "Measured results on RACH" is configured then check that this IE is present. If reporting of "Measured results on RACH" measurement is not configured then no check is needed.	
Additional measured results	This IE does not need to be checked.	
Event results	If reporting of "Event results" is configured then check that this IE is present. If reporting of "Event results" measurement is not configured then no check is needed.	

Contents of MEASUREMENT REPORT message for Inter frequency test cases

Information Element	Value/remark
Message Type Integrity check info	The presence of this IE is dependent on IXIT statements in TS 34.123-2. If integrity protection is indicated to be active, this IE shall be present with the values of the sub IEs as stated below. Else, this IE and the sub-IEs shall be absent.
<ul style="list-style-type: none"> - Message authentication code - RRC Message sequence number 	This IE is checked to see if it is present. The value is compared against the XMAC-I value computed by SS. This IE is checked to see if it is present. The value is used by SS to compute the XMAC-I value.
Measurement identity	2
Measured Results	If reporting of "UTRA Carrier RSSI" measurement is configured then check that this IE is present. If reporting of "UTRA Carrier RSSI" measurement is not configured then no check is needed.
<ul style="list-style-type: none"> - Inter-frequency measured results list - UTRA Carrier RSSI 	
<ul style="list-style-type: none"> - Inter-frequency cell measurement results - Cell measured results - Cell Identity - Cell synchronisation information - Tm 	Not present
<ul style="list-style-type: none"> - OFF 	If reporting of "Tm" measurement is configured then check that this IE is present. If reporting of "Tm" measurement is not configured then no check is needed. If reporting of "OFF" measurement is configured then check that this IE is present. If reporting of "OFF" measurement is not configured then no check is needed.
<ul style="list-style-type: none"> - CHOICE mode - Primary CPICH info - Primary scrambling code - CPICH Ec/N0 	FDD Checked that this IE is present See Annex K and TS 34.108 [3] section 6.1.4 If reporting of "CPICH Ec/N0" measurement is configured then check that this IE is present. If reporting of "CPICH Ec/N0" measurement is not configured then no check is needed..
<ul style="list-style-type: none"> - CPICH RSCP 	If reporting of "CPICH RSCP" measurement is configured then check that this IE is present. If reporting of "CPICH RSCP" measurement is not configured then no check is needed.
<ul style="list-style-type: none"> - Pathloss 	absent
Measured results on RACH	If reporting of "Measured results on RACH" is configured then check that this IE is present. If reporting of "Measured results on RACH" measurement is not configured then no check is needed.
Additional measured results	This IE does not need to be checked.
Event results	If reporting of "Event results" is configured then check that this IE is present.

Contents of MEASUREMENT REPORT message for inter – RAT test cases

Information Element	Value/remark	Version
Message Type Integrity check info - Message authentication code - RRC Message sequence number Measurement identity Measured Results - Inter-RAT measured results list - CHOICE system - GSM - Measured GSM cells - GSM carrier RSSI - CHOICE BSIC - Non verified BSIC - BCCH ARFCN - Observed time difference to GSM cell Measured results on RACH Additional measured results Event results	<p>The presence of this IE is dependent on IXIT statements in TS 34.123-2. If integrity protection is indicated to be active, this IE shall be present with the values of the sub IEs as stated below. Else, this IE and the sub-IEs shall be absent. This IE is checked to see if it is present. The value is compared against the XMAC-I value computed by SS.</p> <p>This IE is checked to see if it is present. The value is used by SS to compute the XMAC-I value.</p> <p>2</p> <p>GSM</p> <p>Checked that this IE is present If reporting of "GSM carrier RSSI" measurement is configured then check that this IE is present. If reporting of "GSM carrier RSSI" measurement is not configured then no check is needed. If reporting of "BSIC verification" measurement is required then check this IE. If reporting of "BSIC verification" measurement is not required then no check is needed. Non verified BSIC If reporting of "BSIC verification" measurement is not required then check this IE. If reporting of "BSIC verification" measurement is required then no check is needed</p> <p>Checked that this IE is present This IE does not need to be checked.</p> <p>If reporting of "Measured results on RACH" is configured then check that this IE is present. If reporting of "Measured results on RACH" measurement is not configured then no check is needed.</p> <p>This IE does not need to be checked.</p> <p>If reporting of "Event results" is configured then check that this IE is present. If reporting of "Event results" measurement is not configured then no check is needed.</p>	<p>R99 and Rel-4 only</p>

Contents of RRC CONNECTION SETUP message: UM (Transition to CELL_DCH)

The following information element is exception of TS34.108 [3] for test cases 7.8.1, 7.8.2, 7.8.3, 7.8.4 and 7.9.1.

Information Element	Value/remark
Added or Reconfigured DL TrCH information - DCH quality target - BLER Quality value	0.0

Contents of Master Information Block PLMN type is the case of GSM-MAP

The following information element is exception of TS34.108 [3] based on monitorlist size for 8.2.3.1, 8.2.3.2, 8.2.3.3, 8.3.4, 8.3.5.3, 8.4.1.1, 8.4.1.2, 8.6.1.1, 8.6.1.1A, 8.6.1.2, 8.6.1.2A, 8.6.1.3, 8.6.1.3A, 8.6.1.4A, 8.6.2.1, 8.6.2.1A, 8.6.2.2, 8.6.2.2A, 8.6.2.3, 8.6.4.1, 8.6.5.1 test cases and based on the maximum SIB repetition period for 8.2.2.1, 8.2.2.2, 8.3.5.1, 8.3.5.2, 8.3.6.1, 8.3.6.2, 8.3.7.1 and 8.3.7.2 test cases.

Information Element	Value/Remark
- SIB_POS	2
- SIB_POS offset info	Not Present
- SIB and SB type	Scheduling Block 1
- SIB_REP	128
- SIB_POS	22
- SIB_POS offset info	Not Present
- SIB and SB type	System Information Type 1
- SIB_REP	128
- SIB_POS	22
- SIB_POS offset info	Not Present
- SIB and SB type	System Information Type 2
- SIB_REP	128
- SIB_POS	20
- SIB_POS offset info	Not Present
- SIB and SB type	System Information Type 3
- SIB_REP	128
- SIB_POS	52
- SIB_POS offset info	Not Present
- SIB and SB type	System Information Type 4
- SIB_REP	128
- SIB_POS	38
- SIB_POS offset info	3
- SIB and SB type	System Information Type 5

Contents of Scheduling Block 1 (FDD)

The following information element is exception of TS34.108 [3] based on SIB repetition period for 8.2.2.1, 8.2.2.2, 8.3.5.1, 8.3.5.2, 8.3.6.1, 8.3.6.2, 8.3.7.1 and 8.3.7.2 test cases.

Information Element	Value/Remark
- References to other system information blocks	
- SIB_REP	128
- SIB_POS	6
- SIB_POS offset info	3
- SIB type SIBs only	System Information Type 6
- SIB_POS	4
- SIB type SIBs only	System Information Type 7
- SEG_COUNT	3
- SIB_REP	128
- SIB_POS	58
- SIB_POS offset info	2
- SIB_OFF	2
- SIB_OFF	2
- SIB type SIBs only	System Information Type 11
- SIB_REP	128
- SIB_POS	26
- SIB_POS offset info	2
- SIB type SIBs only	System Information Type 12
- CHOICE Value tag	Cell Value tag
- Cell Value tag	1
- SIB_REP	128
- SIB_POS	36
- SIB type SIBs only	System Information Type 18

Contents of Scheduling Block 1 (FDD)

The following information element is exception of TS34.108 [3] based on monitorlist size for 8.2.3.1, 8.2.3.2, 8.2.3.3, 8.4.1.1, 8.4.1.2, 8.6.1.1, 8.6.1.1A, 8.6.1.4A, 8.6.2.2, 8.6.2.2A, 8.6.2.3 test cases.

Information Element	Value/Remark
- References to other system information blocks	
- SIB_REP	128
- SIB_POS	6
- SIB_POS offset info	3
- SIB type SIBs only	System Information Type 6
- SIB_POS	4
- SIB type SIBs only	System Information Type 7
- SEG_COUNT	4
- SIB_REP	128
- SIB_POS	54
- SIB_POS offset info	3
- SIB_OFF	4
- SIB_OFF	2
- SIB_OFF	2
- SIB type SIBs only	System Information Type 11
- SIB_REP	128
- SIB_POS	26
- SIB_POS offset info	2
- SIB type SIBs only	System Information Type 12
- CHOICE Value tag	Cell Value tag
- Cell Value tag	1
- SIB_REP	128
- SIB_POS	36
- SIB type SIBs only	System Information Type 18

Contents of System Information Block type 11 (FDD)

The following information element is exception to SIB 11 option A2 as specified in TS34.108 [3] section 6.1.0b based on the monitored list size for 8.3.6.3

Information Element	Value/Remark
- Intra-frequency measurement system information	
- New intra-frequency cells	1
- Intra-frequency cell id	1
- Cell info	Same content as specified for Intra-frequency cell id=1
- Inter-frequency measurement system information	
- New inter-frequency cells	1
- Inter frequency cell id	4
- Frequency info	Same content as specified for Inter-frequency cell id=4
- Cell info	Same content as specified for Inter-frequency cell id=4
- Inter-RAT measurement system information	
- Inter-RAT cell info list	
- New inter-RAT cells	12
- Inter-RAT cell id	11+n (n=0 to 9)
- CHOICE Radio Access Technology	GSM
- GSM	
- Cell individual offset	0
- Cell selection and re-selection info	Not Present
- BSIC	
- Base transceiver Station Identity Code (BSIC)	Chosen arbitrarily by the test house such that it does not collide with BSICs of other Inter-RAT cell ids.
- Band indicator	According to PICS/PIXIT
- BCCH ARFCN	Chosen arbitrarily by the test house such that it does not collide with BCCH ARFCNs of other Inter-RAT cell ids.

Contents of System Information Block type 11 (FDD)

The following information element is exception to SIB 11 option A3 as specified in TS34.108 [3] section 6.1.0b based on the monitored list size for 8.4.1.1, 8.6.1.1, 8.6.1.1A, 8.6.1.4A.

Information Element	Value/Remark
- Intra-frequency measurement system information	
- New intra-frequency cells	24
- Intra-frequency cell id	12+n (n=0 to 17)
- Cell info	Same content as specified for Intra-frequency cell id=2 with the exception that value for Primary scrambling code shall not be overlapped values.
- Inter-frequency measurement system information	Not Present
- Inter-RAT measurement system information	Not Present

The following information element is exception to SIB 11 option A1 as specified in TS34.108 [3] section 6.1.0b based on the monitored list size for 8.4.1.2.

Information Element	Value/Remark
- New intra-frequency cells	18
- Intra-frequency cell id	12+n(n=0 to12)
- Cell info	Same content as specified for Intra-frequency cell id=2 with the exception that value for Primary scrambling code shall not be overlapped values.
- Inter-frequency measurement system information	
- New inter-frequency cells	6
- Inter frequency cell id	7
- Frequency info	
- CHOICE mode	FDD
- UARFCN uplink(Nu)	Not present Absence of this IE is equivalent to applying the default duplex distance defined for the operating frequency according to 3GPP TS 25.101 [11].
- UARFCN downlink(Nu)	A different channel as specified in TS34.108 [3] Table 6.1.4 for Cell 1 and for Cell 4 within the currently used UTRA band.
- Cell info	Same content as specified for Inter-frequency cell id=4
- Inter frequency cell id	8+n (n =0 to 1)
- Frequency info	Not Present Absence of this IE is equivalent to value of the previous "frequency info" in the list.
- Cell info	Same content as specified for Inter-frequency cell id=4
- Inter-RAT measurement system information	Not Present

Contents of System Information Block type 11 (FDD)

The following information element is exception to SIB 11 option A1 as specified in TS34.108 [3] section 6.1.0b based on the monitored list size for 8.6.2.2, 8.6.2.2A, 8.6.2.3.

Information Element	Value/Remark
- New intra-frequency cells - Intra-frequency cell id - Cell info	16 12+n (n=0 to 10) Same content as specified for Intra-frequency cell id=2 with the exception that value for Primary scrambling code shall not be overlapped values.
- Inter-frequency measurement system information - New inter-frequency cells - Inter frequency cell id - Frequency info	8 7+n (n =0 to 4) Not Present Absence of this IE is equivalent to value of the previous "frequency info" in the list.
- Cell info	Same content as specified for Inter-frequency cell id=4 with the exception that value for Primary scrambling code shall not be overlapped values.
- Inter-RAT measurement system information	Not Present

Contents of System Information Block type 11 (FDD)

The following information element is exception to SIB 11 option A1 as specified in TS34.108 [3] section 6.1.0b based on the monitored list size for tests 8.2.2.2, 8.3.5.2, and 8.3.6.2.

Information Element	Value/Remark
- New intra-frequency cells	3
- Intra-frequency cell id	1
- Cell info	Same content as specified for Intra-frequency cell id=1
- Intra-frequency cell id	2
- Cell info	Same content as specified for Intra-frequency cell id=2
- Intra-frequency cell id	3
- Cell info	Same content as specified for Intra-frequency cell id=3
- Inter-frequency measurement system information	
- New inter-frequency cells	3
- Inter frequency cell id	4
- Frequency info	Same content as specified for Intra-frequency cell id=4
- Cell info	Same content as specified for Inter-frequency cell id=4
- Inter frequency cell id	5
- Frequency info	Not Present Absence of this IE is equivalent to value of the previous "frequency info" in the list.
- Cell info	Same content as specified for Inter-frequency cell id=5
- Inter frequency cell id	6
- Frequency info	Not Present Absence of this IE is equivalent to value of the previous "frequency info" in the list.
- Cell info	Same content as specified for Inter-frequency cell id=6
- Inter-RAT measurement system information	Not Present

Contents of Scheduling Block 1 (FDD)

The following information element is exception of TS34.108 [3] based on monitorlist size for 8.3.4, 8.3.5.3, 8.6.1.2,8.6.1.2A, 8.6.1.3, 8.6.1.3A, 8.6.4.1.

Information Element	Value/Remark
- References to other system information blocks	
- SIB_REP	128
- SIB_POS	6
- SIB_POS offset info	3
- SIB type SIBs only	System Information Type 6
- SIB_POS	4
- SIB type SIBs only	System Information Type 7
- SEG_COUNT	5
- SIB_REP	128
- SIB_POS	54
- SIB_POS offset info	4
- SIB_OFF	4
- SIB_OFF	2
- SIB_OFF	2
- SIB_OFF	8
- SIB type SIBs only	System Information Type 11
- SIB_REP	128
- SIB_POS	26
- SIB_POS offset info	2
- SIB type SIBs only	System Information Type 12
- CHOICE Value tag	Cell Value tag
- SIB_REP	128
- SIB_POS	36
- SIB type SIBs only	System Information Type 18

Contents of System Information Block type 11 (FDD)

The following information element is exception to SIB 11 option A2 as specified in TS34.108 [3] section 6.1.0b based on the monitored list size for 8.3.4, 8.3.5.3, 8.6.4.1.

Information Element	Value/Remark
- Intra-frequency measurement system information	
- New intra-frequency cells	24
- Intra-frequency cell id	7+n (n=0, 1, 4 to 22)
- Cell info	Same content as specified for Intra-frequency cell id=2 with the exception that value for Primary scrambling code shall not be overlapped values.
- Inter-frequency measurement system information	Not present
- Inter-RAT measurement system information	
- Inter-RAT cell info list	
- New inter-RAT cells	6
- Inter-RAT cell id	11+n (n=0 to 3)
- CHOICE Radio Access Technology	GSM
- GSM	
- Cell individual offset	0
- Cell selection and re-selection info	Not Present
- BSIC	
- Base transceiver Station Identity Code (BSIC)	Chosen arbitrarily by the test house such that it does not collide with BSICs of other Inter-RAT cell ids.
- Band indicator	According to PICS/PIXIT
- BCCH ARFCN	Chosen arbitrarily by the test house such that it does not collide with BCCH ARFCNs of other Inter-RAT cell ids.

The following information element is exception to SIB11 option A2 as specified in TS34.108 [3] based on monitorlist size for 8.2.3.1, 8.2.3.2 and 8.2.3.3

Information Element	Value/Remark
- Inter-frequency measurement system information	Not present
- Inter-RAT measurement system information	
- Inter-RAT cell info list	
- Inter-RAT cell id	11+n (n=0 to 9)
- CHOICE Radio Access Technology	GSM
- GSM	
- Cell individual offset	0
- Cell selection and re-selection info	Not Present
- BSIC	
- Base transceiver Station Identity Code (BSIC)	Chosen arbitrarily by the test house such that it does not collide with BSICs of other Inter-RAT cell ids.
- Band indicator	According to PICS/PIXIT
- BCCH ARFCN	Chosen arbitrarily by the test house such that it does not collide with BCCH ARFCNs of other Inter-RAT cell ids.

Contents of System Information Block type 11 (FDD)

The following information element is exception to SIB 11 option A3 as specified in TS34.108 [3] section 6.1.0b based on the monitored list size for 8.6.1.2, 8.6.1.2A, 8.6.1.3, 8.6.1.3A.

Information Element	Value/Remark
- Intra-frequency measurement system information	
- New intra-frequency cells	32
- Intra-frequency cell id	n(n=0, 4, 5, 6, 9, 10 and 12 to 31)
- Cell info	Same content as specified for Intra-frequency cell id=2 with the exception that value for Primary scrambling code shall not be overlapped values.
- Inter-frequency measurement system information	Not Present
- Inter-RAT measurement system information	Not Present

Contents of Scheduling Block 1 (FDD)

The following information element is exception of TS34.108 [3] based on monitorlist size for 8.6.2.1, 8.6.2.1A, 8.6.5.1 test case.

Information Element	Value/Remark
- References to other system information blocks	
- SIB_REP	128
- SIB_POS	6
- SIB_POS offset info	3
- SIB type SIBs only	System Information Type 6
- SIB_POS	4
- SIB type SIBs only	System Information Type 7
- SEG_COUNT	6
- SIB_REP	128
- SIB_POS	54
- SIB_POS offset info	5
- SIB_OFF	4
- SIB_OFF	2
- SIB_OFF	2
- SIB_OFF	8
- SIB_OFF	4
- SIB type SIBs only	System Information Type 11
- SIB_REP	128
- SIB_POS	26
- SIB_POS offset info	2
- SIB type SIBs only	System Information Type 12
- CHOICE Value tag	Cell Value tag
- Cell Value tag	1
- SEG_COUNT	1
- SIB_REP	128

- SIB_POS - SIB type SIBs only	36 System Information Type 18
-----------------------------------	----------------------------------

Contents of System Information Block type 11 (FDD)

The following information element is exception to SIB 11 option A1 as specified in TS34.108 [3] section 6.1.0b based on the monitored list size for 8.6.2.1, 8.6.2.1A.

Information Element	Value/Remark
- New intra-frequency cells	24
- Intra-frequency cell id	12+n(n=0 to18)
- Cell info	Same content as specified for Intra-frequency cell id=2 with the exception that value for Primary scrambling code shall not be overlapped values.
- Inter-frequency measurement system information	
- New inter-frequency cells	16
- Inter frequency cell id	7+n (n =0 to 12)
- Frequency info	Not Present
Absence of this IE is equivalent to value of the previous "frequency info" in the list.	
- Cell info	Same content as specified for Inter-frequency cell id=4 with the exception that value for Primary scrambling code shall not be overlapped values.
- Inter-RAT measurement system information	Not Present

Contents of System Information Block type 11 (FDD)

The following information element is exception to SIB 11 option A2 as specified in TS34.108 [3] section 6.1.0b based on the monitored list size for 8.6.5.1.

Information Element	Value/Remark
- New intra-frequency cells	16
- Intra-frequency cell id	12+n(n=0 to12)
- Cell info	Same content as specified for Intra-frequency cell id=2 with the exception that value for Primary scrambling code shall not be overlapped values.
- Inter-frequency measurement system information	
- New inter-frequency cells	8
- Inter frequency cell id	25+n (n =0 to 4)
- Frequency info	Not Present
Absence of this IE is equivalent to value of the previous "frequency info" in the list.	
- Cell info	Same content as specified for Inter-frequency cell id=4 with the exception that value for Primary scrambling code shall not be overlapped values.
- Inter-RAT measurement system information	
- New inter-RAT cells	6
- Inter-RAT cell id	11+n (n=0 to 3)
- CHOICE Radio Access Technology	GSM
- GSM	
- Cell individual offset	0
- Cell selection and re-selection info	Not Present
- BSIC	
- Base transceiver Station Identity Code (BSIC)	Chosen arbitrarily by the test house such that it does not collide with BSICs of other Inter-RAT cell ids.
- Band indicator	According to PICS/PIXIT
- BCCH ARFCN	Chosen arbitrarily by the test house such that it does not collide with BCCH ARFCNs of other Inter-RAT cell ids.

Contents of System Information Block type 11 (FDD)

The following information element is exception to SIB 11 option A2 as specified in TS34.108 [3] section 6.1.0b based on the monitored list size for 8.7.3a

Information Element	Value/Remark
<ul style="list-style-type: none"> - Inter-frequency measurement system information - Inter-RAT measurement system information - Inter-RAT cell info list <ul style="list-style-type: none"> - Inter-RAT cell id - CHOICE <i>Radio Access Technology</i> <ul style="list-style-type: none"> - GSM - Cell individual offset - Cell selection and re-selection info - BSIC <ul style="list-style-type: none"> - Base transceiver Station Identity Code (BSIC) - Band indicator - BCCH ARFCN 	<ul style="list-style-type: none"> Not present 11+n (n=0 to 3) GSM 0 Not Present BSIC(1+n) for n=0, 1 according to 34.108 [3] Table 6.1.10; for n=2 to 3 chosen arbitrarily by the test house such that it does not collide with BSICs of other Inter-RAT cell ids According to PICS/PIXIT BCCH(1+n) according to Table 8.7.3A.4

Contents of TRANSPORT CHANNEL RECONFIGURATION message for test cases with HSDPA in clauses 5.2A, 5.2C, 5.7A, 5.9A, 5.10A and 5.13.1A (Rel-5 and later releases).

Information Element	Value/remark	Version
Message Type		
RRC transaction identifier	Arbitrarily selects an integer between 0 and 3	
Integrity check info		
- message authentication code	SS calculates the value of MAC-I for this message and writes to this IE. The first/leftmost bit of the bit string contains the most significant bit of the MAC-I.	
- RRC message sequence number	SS provides the value of this IE, from its internal counter.	
Integrity protection mode info	Not Present	
Ciphering mode info	Not Present	
Activation time	Not Present	
New U-RNTI	Not Present	
New C-RNTI	Not Present	
New H-RNTI	'1010 1010 1010 1010'	
RRC State indicator	CELL_DCH	
UTRAN DRX cycle length coefficient	Not Present	
CN information info	Not Present	
URA identity	Not Present	
Downlink counter synchronisation info	Not Present	
UL Transport channel information for all transport channels		
- PRACH TFCS	Not Present	
- CHOICE mode	FDD	
- TFC subset	Not Present	
- UL DCH TFCS		
- CHOICE TFCI signalling	Normal	
- TFCI Field 1 information		
- CHOICE TFCS representation	Complete reconfiguration	
- TFCS complete reconfigure information		
- CHOICE CTFC Size	Same as used in the call set up.	
- CTFC information	This IE is repeated for TFC numbers used in the call set up	
- CTFC	Same as used in the call set up.	
- Power offset information		
- CHOICE Gain Factors	Computed Gain Factors except for the reference TFC (TF1, TF1) when Signalled Gain Factors is used	
- Gain factor β_c	Value used in test (Not Present if the CHOICE Gain Factors is set to Computed Gain Factors)	
- Gain factor β_d	Value used in test (Not Present if the CHOICE Gain Factors is set to Computed Gain Factors)	
- Reference TFC ID	0	
- CHOICE mode	FDD	
- Power offset P _{p-m}	Not Present	
Added or Reconfigured UL TrCH information list	Not Present	
CHOICE mode	Not Present	
DL Transport channel information common for all transport channel	Not Present	
Added or Reconfigured DL TrCH information list	Not Present	
Frequency info	Not Present	
Maximum allowed UL TX power	Not Present	
CHOICE channel requirement	Uplink DPCH info	
- Uplink DPCH power control info		
- CHOICE mode	FDD	
- DPCCH power offset	-80dB	
- PC Preamble	1 frame	
- SRB delay	7 frames	
- Power Control Algorithm	Algorithm1 or as specified in the test	
- TPC step size	1dB	
- Δ_{ACK}	Value used in test	
- Δ_{NACK}	Value used in test	

Information Element	Value/remark	Version
<ul style="list-style-type: none"> - Ack-Nack repetition factor - CHOICE mode - Scrambling code type - Scrambling code number - Number of DPDCH - spreading factor - TFCI existence - Number of FBI bit - Puncturing Limit CHOICE Mode	3(required for continuous HS-DPCCH signal) FDD Long 0 (0 to 16777215) Not Present (1) Reference to TS34.121 clause C.2.1 Parameter Set TRUE Not Present(0) 1 Not present	
Downlink HS-PDSCH Information <ul style="list-style-type: none"> - HS-SCCH Info - Measurement Feedback Info <ul style="list-style-type: none"> - CHOICE mode - POhsdsch - CQI Feedback cycle, k - CQI repetition factor - Δ_{CQI} - CHOICE mode 	Not Present FDD 6 dB 4 ms 2(required for continuous HS-DPCCH signal) Value used in test FDD (no data)	
Downlink information common for all radio links	Not Present	
Downlink information per radio link list	Not Present	

Contents of ACTIVE SET UPDATE message for test cases with SHO in clauses 7.7.1, 7.7.1A, 7.7.2, and 7.7.3.

ACTIVESET UPDATE message (Radio link addition information)

Information Element/Group name	Value/Remark	Version
Message Type (10.2.17)		
UE information elements - RRC transaction identifier - Integrity check info -message authentication code -RRC message sequence number - Activation time - New U-RNTI	0 SS calculates the value of MAC-I for this message and writes to this IE. The first/ leftmost bit of the bit string contains the most significant bit of the MAC-I. SS provides the value of this IE, from its internal counter. "now". Not Present	
CN information elements - CN Information info	Not Present	
Phy CH information elements Uplink radio resources - Maximum allowed UL TX power	33 dBm	
Downlink radio resources - Radio link addition information - Radio link addition information - Primary CPICH info - Primary scrambling code - Downlink DPCH info for each RL	#of Adding Cells Same as adding cell	
- CHOICE mode - Primary CPICH usage for channel estimation - DPCH frame offset - Secondary CPICH info	FDD Primary CPICH may be used This should be reflected by the IE" Cell synchronisation information" in received MEASUREMENT REPORT message Not Present	
- DL channelisation code - Secondary scrambling code - Spreading factor - Code number - Scrambling code change - TPC combination index - SSDT Cell Identity - Closed loop timing adjustment mode - TFCI combining indicator - SCCPCH Information for FACH - Radio link removal information - TX Diversity Mode	Not Present 128 96 No code change different value for each new cell Not Present Not Present FALSE Not Present Not Present Not Present	R99 and Rel-4 only
- SSDT information	Not Present	R99 and Rel-4 only

Contents of ACTIVE SET UPDATE message for test cases with SHO in clauses 8.6.1.1, 8.6.1.2 and 8.6.1.3
ACTIVESET UPDATE message (Radio link addition information)

Information Element/Group name	Value/Remark	Version
Message Type (10.2.17)		
UE information elements - RRC transaction identifier - Integrity check info -message authentication code -RRC message sequence number - Activation time - New U-RNTI	0 SS calculates the value of MAC-I for this message and writes to this IE. The first/ leftmost bit of the bit string contains the most significant bit of the MAC-I. SS provides the value of this IE, from its internal counter. "now". Not Present	
CN information elements - CN Information info	Not Present	
Phy CH information elements Uplink radio resources - Maximum allowed UL TX power	33 dBm	
Downlink radio resources - Radio link addition information - Radio link addition information - Primary CPICH info - Primary scrambling code - Downlink DPCH info for each RL	1 Same as adding cell	
- CHOICE mode - Primary CPICH usage for channel estimation - DPCH frame offset - Secondary CPICH info	FDD Primary CPICH may be used This should be reflected by the IE" Cell synchronisation information" in received MEASUREMENT REPORT message Not Present	
- DL channelisation code - Secondary scrambling code - Spreading factor - Code number - Scrambling code change - TPC combination index - SSTD Cell Identity - Closed loop timing adjustment mode - TFCI combining indicator - SCCPCH Information for FACH - Radio link removal information - TX Diversity Mode	Not Present 128 96 No code change 0 (Note: This requires that SS sends the same TPC commands from all cells in the active set) Not Present Not Present FALSE Not Present Not Present Not Present	R99 and Rel-4 only
- SSTD information	Not Present	R99 and Rel-4 only

ACTIVESET UPDATE message (Radio link removal information)

Information Element/Group name	Value/Remark	Version
Message Type (10.2.17)		
UE information elements - RRC transaction identifier - Integrity check info -message authentication code -RRC message sequence number - Activation time - New U-RNTI	0 SS calculates the value of MAC-I for this message and writes to this IE. The first/ leftmost bit of the bit string contains the most significant bit of the MAC-I. SS provides the value of this IE, from its internal counter. "now". Not Present	
CN information elements - CN Information info	Not Present	
Phy CH information elements Uplink radio resources - Maximum allowed UL TX power	33 dBm	
Downlink radio resources - Radio link addition information - Radio link removal information - Primary CPICH info - Primary scrambling code - TX Diversity Mode	Not Present 1 Same as removing cell Not Present	
- SSDT information	Not Present	R99 and Rel-4 only

Scrambling codes for cell2 and cell3 in clauses 8.6.1.1, 8.6.1.1A, 8.6.1.2, 8.6.1.2A, 8.6.1.3, 8.6.1.3A, 8.6.1.4A, 8.6.2.1, 8.6.2.1A, 8.6.2.2, 8.6.2.2A, 8.6.2.3.

Test Case	Cell2	Cell3
8.6.1.1, 8.6.1.1A, 8.6.1.4A	150,400,450	-
8.6.1.2, 8.6.1.2A, 8.6.1.3, 8.6.1.3A	150,400,450	200,500,50
8.6.2.1, 8.6.2.1A	150,400,450	250,300,350
8.6.2.2, 8.6.2.2A, 8.6.2.3	250,300,350	-

Scrambling codes for cell1 in clauses 8.6.1.5 and 8.6.1.6.

Test Case	Cell1
8.6.1.5, 8.6.1.6	100, 400, 450

Annex J (informative): Information about special regional application of test cases and requirements

This annex provides information about special regional application of the tests specified in the core part of the present document. The special regional application of certain test cases is typically caused by specific local regulation and legalisation.

J.1 Japan

For regulatory testing in Japan shared risk against core specification value with test tolerance of zero may be applied provisionally, until the time the non-zero test tolerances principle used in the present document is reflected in Japanese regulations, The shared risk principle described above will apply to the following requirements:

- 5.9 Spectrum Emission Mask;

NOTE: This information should be reviewed on a regular basis to check its applicability, as changes to regulation allowing usage of the non-zero test tolerances principle are expected.

Annex K (normative): Cell configuration mapping

The cells defined in TS 25.133 [2] and used in TS 34.121 do not correspond to the cells defined in TS 34.108 [3] section 6.1.4. Table K.1 describes the mapping between cells described in TS 34.121 and those defined in TS 34.108 [3]. For each test case in section 8 the cells as defined in TS 34.108 [3] section 6.1.4 are listed in one row. The test case shall apply the RF parameters as defined in TS 34.121 according to the column heading. The use of cells as defined in TS 34.108 [3] section 6.1.4 is important in order to have consistent SIB11 configurations between the different cells.

Note: For example if the second cell in a test case is an inter-frequency cell then Cell4 from TS 34.108 [3] section 6.1.4 is used with the radio parameters as defined for Cell2 in TS 34.121.

Table K.1: Cell configuration mapping for RF testing

Test Case	Description	34.121 Cell1	34.121 Cell2	34.121 Cell3	34.121 Cell4	34.121 Cell5	34.121 Cell6
8.2.2.1	Idle Mode / Cell Re-Selection / Scenario 1:Single carrier case	Cell1	Cell2	Cell3	Cell7	Cell8	Cell11
8.2.2.2	Idle Mode / Cell Re-Selection / Scenario 2:Multi carrier case	Cell1	Cell4	Cell2	Cell3	Cell5	Cell6
8.2.3.1	Idle Mode / UTRAN to GSM Cell Re-Selection/ Scenario 1: Both UTRA and GSM level changed	Cell1	Cell9				
8.2.3.2	Idle Mode / UTRAN to GSM Cell Re-Selection/ Scenario 2: Only UTRA level changed	Cell1	Cell9				
8.2.3.3	Idle Mode / UTRAN to GSM Cell Re-Selection/ Scenario 3: HCS with only UTRA level changed	Cell1	Cell9				
8.2.4	Idle Mode / FDD/TDD Cell Re-selection	Cell1	TDD				
8.3.1	UTRAN Connected Mode Mobility / FDD/FDDSoft Handover	Cell1	Cell2				
8.3.2.1	UTRAN Connected Mode Mobility / FDD/FDDHard Handover to intra-frequency cell	Cell1	Cell2				
8.3.2.2	UTRAN Connected Mode Mobility / FDD/FDDHard Handover to inter-frequency cell	Cell1	Cell4				
8.3.3	UTRAN Connected Mode Mobility / FDD/TDDHard Handover	Cell1	TDD				
8.3.4	UTRAN Connected Mode Mobility /Inter-system Handover from UTRAN FDD to GSM	Cell1	Cell9				
8.3.5.1	UTRAN Connected Mode Mobility / CellRe-selection in CELL_FACH / One frequency present in neighbour list	Cell1	Cell2	Cell3	Cell7	Cell8	Cell11
8.3.5.2	UTRAN Connected Mode Mobility / CellRe-selection in CELL_FACH / Two frequencies present in the neighbour list	Cell1	Cell4	Cell2	Cell3	Cell5	Cell6
8.3.5.3	UTRAN Connected Mode Mobility / CellRe-selection in CELL_FACH / Cell Reselection to GSM	Cell1	Cell9				
8.3.6.1	UTRAN Connected Mode Mobility / CellRe-selection in CELL_PCH / One frequency present in the neighbour list	Cell1	Cell2	Cell3	Cell7	Cell8	Cell11
8.3.6.2	UTRAN Connected Mode Mobility / CellRe-selection in CELL_PCH / Two frequencies present in the neighbour list	Cell1	Cell4	Cell2	Cell3	Cell5	Cell6
8.3.6.3	UTRAN Connected Mode Mobility / CellRe-selection in CELL_PCH / Cell re-selection during an MBMS session, one UTRAN inter-frequency and 2 GSM cells present in the neighbour list	Cell1	Cell4	Cell10	Cell9		
8.3.7.1	UTRAN Connected Mode Mobility / CellRe-selection in URA_PCH / One frequency present in the neighbour list	Cell1	Cell2	Cell3	Cell7	Cell8	Cell11
8.3.7.2	UTRAN Connected Mode Mobility / CellRe-selection in URA_PCH / Two frequencies present in the neighbour list	Cell1	Cell4	Cell2	Cell3	Cell5	Cell6
8.3.8	Serving HS-DSCH cell change	Cell1	Cell2				
8.4.1.1	RRC Connection Control / RRCRe-establishment delay / Test 1	Cell1	Cell2				
8.4.1.2	RRC Connection Control / RRCRe-establishment delay / Test 2	Cell1	Cell4				
8.4.2.1	RRC Connection Control / Random Access /Correct behaviour when receiving an ACK	Cell1					
8.4.2.1A	RRC Connection Control / Random Access /Correct behaviour when receiving an ACK	Cell1					
8.4.2.2	RRC Connection Control / Random Access /Correct behaviour when receiving an NACK	Cell1					
8.4.2.3	RRC Connection Control / Random Access /Correct behaviour at Time-out	Cell1					
8.4.2.4	RRC Connection Control / Random Access /Correct behaviour when reaching maximum transmit power	Cell1					

8.4.3.1	RRC Connection Control / Transport format combination selection in UE / Interactive or Background, PS, UL: 64 kbps	Cell1					
8.4.4.1	RRC Connection Control / E-TFC restriction in UE / 10ms TTI E-DCH E-TFC restriction	Cell1					
8.4.4.2	RRC Connection Control / E-TFC restriction in UE / 2ms TTI E-DCH E-TFC restriction	Cell1					
8.5.1	Timing and Signalling Characteristics / UETransmit Timing	Cell1	Cell2				
8.6.1.1	FDD intrafrequency measurements / Event triggered reporting in AWGN propagation conditions	Cell1	Cell2				
8.6.1.1A	FDD intrafrequency measurements / Event triggered reporting in AWGN propagation conditions	Cell1	Cell2				
8.6.1.2	FDD intrafrequency measurements / Event triggered reporting of multiple neighbours inAWGN propagation condition	Cell1	Cell2	Cell3			
8.6.1.2A	FDD intrafrequency measurements / Event triggered reporting of multiple neighbours inAWGN propagation condition	Cell1	Cell2	Cell3			
8.6.1.3	FDD intrafrequency measurements / Event triggered reporting of two detectable neighbours in AWGN propagation condition	Cell1	Cell2	Cell3			
8.6.1.3A	FDD intrafrequency measurements / Event triggered reporting of two detectable neighbours in AWGN propagation condition	Cell1	Cell2	Cell3			
8.6.1.4A	FDD intrafrequency measurements / Correct reporting of neighbours in fading propagation condition	Cell1	Cell2				
8.6.1.5	FDD intrafrequency measurements / Event triggered reporting of multiple neighbour cells in Case 1 fading condition	Cell1	Cell2	Cell3	Cell4		
8.6.1.6	FDD intrafrequency measurements / Event triggered reporting of multiple neighbour cells in Case 3 fading conditions	Cell1	Cell2	Cell3	Cell4		
8.6.2.1	FDD interfrequency measurements / Correct reporting of neighbours in AWGN propagation condition	Cell1	Cell2	Cell4			
8.6.2.2	FDD interfrequency measurements / Correct reporting of neighbours in fading propagation condition	Cell1	Cell4				
8.6.3.1	TDD measurements / Correct reporting of TDD neighbours in AWGN propagation condition	Cell1	TDD				
8.6.4.1	GSM measurements / Correct reporting of GSMneighbours in AWGN propagation condition	Cell1	Cell9				
8.6.5.1	Combined Interfrequency and GSM measurements/ Correct reporting of neighbours in AWGN propagation condition	Cell1	Cell4	Cell9			
8.7.1.1.1	Measurements Performance Requirements /CPICH RSCP / Intra frequency measurements accuracy / Absolute accuracy requirement	Cell1	Cell2				
8.7.1.1.2	Measurements Performance Requirements /CPICH RSCP / Intra frequency measurements accuracy / Relative accuracy requirement	Cell1	Cell2				
8.7.1.2.1	Measurements Performance Requirements /CPICH RSCP / Inter frequency measurement accuracy / Relative accuracy requirement	Cell1	Cell4				
8.7.2.1.1	Measurements Performance Requirements /CPICH Ec/Io / Intra frequency measurements accuracy / Absolute accuracy requirement	Cell1	Cell2				
8.7.2.1.2	Measurements Performance Requirements /CPICH Ec/Io / Intra frequency measurements accuracy / Relative accuracy requirement	Cell1	Cell2				
8.7.2.2.1	Measurements Performance Requirements /CPICH Ec/Io / Inter frequency measurement accuracy / Absolute accuracy requirement	Cell1	Cell4				

8.7.2.2.2	Measurements Performance Requirements /CPICH Ec/Io / Inter frequency measurement accuracy / Relative accuracy requirement	Cell1	Cell4				
8.7.3.1	Measurements Performance Requirements /UTRA Carrier RSSI / Absolute measurement accuracy requirement	Cell1	Cell4				
8.7.3.2	Measurements Performance Requirements /UTRA Carrier RSSI / Relative measurement accuracy requirement	Cell1	Cell4	Cell7			
8.7.3A	Measurements Performance Requirements / GSMCarrier RSSI	Cell1	Cell9	Cell10	GSM	GSM	GSM
8.7.3B	Measurements Performance Requirements /Transport channel BLER						
8.7.3C	Measurements Performance Requirements / UE transmitted power	Cell1					
8.7.3D	Measurements Performance Requirements / UE transmitted power	Cell1					
8.7.4.1	Measurements Performance Requirements /SFN-CFN observed time difference /Intra frequency measurement requirement	Cell1	Cell2				
8.7.4.2	Measurements Performance Requirements /SFN-CFN observed time difference /Inter frequency measurement requirement	Cell1	Cell4				
8.7.5.1	Measurements Performance Requirements /SFN-SFN observed time difference / SFN-SFN observed time difference type 1	Cell1	Cell2				
8.7.5.2	Measurements Performance Requirements /SFN-SFN observed time difference / SFN-SFN observed time difference type 2 without IPDL period active	Cell1	Cell2				
8.7.5.3	Measurements Performance Requirements /SFN-SFN observed time difference / SFN-SFN observed time difference type 2 with IPDL period active	Cell1	Cell2				
8.7.6.1	Measurements Performance Requirements / UERx-Tx time difference / UE Rx-Tx time difference type 1	Cell1					
8.7.6.2	Measurements Performance Requirements / UERx-Tx time difference/ UE Rx- Tx time difference type 2	Cell1	Cell2				
8.7.7	Measurements Performance Requirements /Observed time difference to GSM cell						
8.7.8.1	Measurements Performance Requirements / P-CCPCH RSCP / Absolute measurement accuracy	Cell1	TDD				
8.7.9	Measurements Performance Requirements / UE Transmission Power Headroom	Cell1					

Annex L (informative): Change history

T Meeting	Doc-1 st -Level	CR	Rev	Subject	Cat	Version - Current	Version -New	Doc-2 nd -Level
TP-07				Approval of the specification		2.0.0	3.0.0	
				No change: replaces invalid zip file on server		3.0.0	3.0.1	
TP-08	TP-000090	001		Editorial corrections to clauses 2, 3, 4 and 5.1	D	3.0.1	3.1.0	T1-000059
TP-08	TP-000090	002		Modifications to clause 5.4 "Output Power Dynamics in the Uplink"	C	3.0.1	3.1.0	T1-000060
TP-08	TP-000090	003		Out-of-synchronisation handling of the UE	B	3.0.1	3.1.0	T1-000061
TP-08	TP-000090	004		Modifications to clauses 5.8, 5.9, 5.10 and 5.11	D	3.0.1	3.1.0	T1-000062
TP-08	TP-000090	005		Modifications to Chapter 6 "Receiver Characteristics"	F	3.0.1	3.1.0	T1-000063
TP-08	TP-000090	006		Modifications to Annex D, Annex E, Annex G and Annex H	F	3.0.1	3.1.0	T1-000067
TP-08	TP-000090	008		Modifications to clauses 5.5, 5.6 and 5.7	F	3.0.1	3.1.0	T1-000069
TP-08	TP-000090	009		Modifications to Chapter 7 "Performance requirements"	F	3.0.1	3.1.0	T1-000070
TP-08	TP-000090	010		Modifications to test power control in downlink	F	3.0.1	3.1.0	T1-000071
TP-08	TP-000090	011		Modifications to clause 5.13 "Transmit Modulation"	F	3.0.1	3.1.0	T1-000072
TP-08	TP-000090	012		Modifications to test for inner loop power control in the uplink	F	3.0.1	3.1.0	T1-000073
TP-08	TP-000090	013		Revision of Annex B: Global in-channel Tx test	F	3.0.1	3.1.0	T1-000074
TP-08	TP-000090	014		Blind transport format detection	B	3.0.1	3.1.0	T1-000075
TP-08	TP-000090	015		Removal of Annex I "Open Items"	D	3.0.1	3.1.0	T1-000077
TP-08	TP-000090	016		Modifications to Chapter 8 "Requirements for support of RRM"	C	3.0.1	3.1.0	T1-000117
TP-08	TP-000090	017		Modifications to Annex C "Measurement channels"	F	3.0.1	3.1.0	T1-000118
TP-08	TP-000090	018		Idle mode test cases (test of performance requirements)	F	3.0.1	3.1.0	T1-000119
TP-09	TP-000163	019		Editorial corrections for References and Frequency Stability (2, 5.2, 5.3)	F	3.1.0	3.2.0	T1-000131
TP-09	TP-000163	020		Corrections for Output Power Dynamics in the Uplink (5.4)	F	3.1.0	3.2.0	T1-000132
TP-09	TP-000163	021		Transients for uplink inner loop power control (5.4.2.4.2)	F	3.1.0	3.2.0	T1-000133
TP-09	TP-000163	022		Transmit On/Off power (5.5.2.4.2)	F	3.1.0	3.2.0	T1-000134
TP-09	TP-000163	023		Change of TFC (5.6.4.2)	F	3.1.0	3.2.0	T1-000135
TP-09	TP-000163	024		Clarification of the definition on Peak Code Domain Error (5.13.2.1)	F	3.1.0	3.2.0	T1-000139
TP-09	TP-000163	025		UE interfering signal definition (6.3, 6.4, 6.5, 6.7)	F	3.1.0	3.2.0	T1-000140
TP-09	TP-000163	026		Performance requirements (7.1, 7.2, 7.3, 7.4, 7.5)	F	3.1.0	3.2.0	T1-000143
TP-09	TP-000163	027		CR on clause 7.6 and 7.7 in TS34.121 (7.6, 7.7)	F	3.1.0	3.2.0	T1-000144
TP-09	TP-000163	028		Performance requirements (7.9, 7.10, 7.11)	F	3.1.0	3.2.0	T1-000146
TP-09	TP-000163	029		Corrections for Annex D (Annex-D)	F	3.1.0	3.2.0	T1-000147
TP-09	TP-000163	030		Corrections for Annex E (Annex-E)	F	3.1.0	3.2.0	T1-000148
TP-09	TP-000163	031		Corrections for Transmit ON/OFF Power, Change of TFC and Power setting in uplink compressed mode (5.5, 5.6, 5.7)	F	3.1.0	3.2.0	T1-000149
TP-09	TP-000163	032		Corrections for power setting in uplink compressed mode (5.7)	F	3.1.0	3.2.0	T1-000136
TP-09	TP-000163	033		CR for subclause 7.8: Power control in downlink (7.8)	B	3.1.0	3.2.0	T1-000145
TP-09	TP-000163	034		Corrections to clause 5.8, 5.9, 5.10, 5.11 and 5.12	F	3.1.0	3.2.0	T1-000137
TP-09	TP-000163	035		Corrections to EVM and PCDE formulae (B.2.7.1, B.2.7.2)	F	3.1.0	3.2.0	T1-000138
TP-09	TP-000163	036		New initial conditions for Spurious emission test case (6.8.4.1)	F	3.1.0	3.2.0	T1-000141
TP-09	TP-000163	037		C.4.1 UL reference measurement channel for BTFD performance requirement (C.4.1)	F	3.1.0	3.2.0	T1-000142
TP-10	TP-000216	038		Corrections to Chapter 3 "Definitions, symbols, abbreviations and equations"	D	3.2.0	3.3.0	T1-000247
TP-10	TP-000216	039		Vocabulary Corrections	D	3.2.0	3.3.0	T1-000253
TP-10	TP-000216	040		Reference Measurement Channels in Annex C	F	3.2.0	3.3.0	T1-000238
TP-10	TP-000216	041		Inclusion of OCNS definition for performance tests	F	3.2.0	3.3.0	T1-000241
TP-10	TP-000216	042		Handling of measurement uncertainties in UE conformance testing (FDD)	F	3.2.0	3.3.0	T1-000250
TP-10	TP-000216	043		Update of Idle mode test cases	F	3.2.0	3.3.0	T1-000252
TP-10	TP-000216	044		UE emission mask measurement filter definition	F	3.2.0	3.3.0	T1-000254

T Meeting	Doc-1 st -Level	CR	Rev	Subject	Cat	Version - Current	Version -New	Doc-2 nd -Level
				correction				
TP-10	TP-000216	045		New structure of TS 34.121	F	3.2.0	3.3.0	T1-000255
TP-10	TP-000216	046		Test for combining TPC commands in soft handover	F	3.2.0	3.3.0	T1-000239
TP-10	TP-000216	047		Corrections to power control tests	F	3.2.0	3.3.0	T1-000240
TP-10	TP-000216	048		Correction to Open Loop Power Control in Uplink	F	3.2.0	3.3.0	T1-000242
TP-10	TP-000216	049		Correction to Transmit ON/OFF Time mask	F	3.2.0	3.3.0	T1-000243r
TP-10	TP-000216	050		Correction to Spurious Emission test	F	3.2.0	3.3.0	T1-000244
TP-10	TP-000216	051		Correction of spurious emission measurement procedure	F	3.2.0	3.3.0	T1-000245
TP-10	TP-000216	052		Out-of-synchronization handling of output power	F	3.2.0	3.3.0	T1-000246
TP-10	TP-000216	053		Clarification of test procedure and test requirement for receiver blocking and spurious response.	F	3.2.0	3.3.0	T1-000248
TP-10	TP-000216	054		Subclause 7.8 Power control in downlink	F	3.2.0	3.3.0	T1-000249
TP-10	TP-000216	055		Downlink compressed mode	F	3.2.0	3.3.0	T1-000251
TP-11	TP-010019	056		CR on Test tolerance for 6.5 Blocking Characteristics	F	3.3.0	3.4.0	T1-010020
TP-11	TP-010019	057		CR on Test tolerance for 6.7 Intermodulation Characteristics	F	3.3.0	3.4.0	T1-010025
TP-11	TP-010019	058		CR on Test tolerance for 5.5.1 Test Tolerance for Transmit OFF power	F	3.3.0	3.4.0	T1-010027
TP-11	TP-010019	059		CR on Test tolerance for 6.6 Spurious Response	F	3.3.0	3.4.0	T1-010028
TP-11	TP-010019	060		CR on Test tolerance for 5.11 Test Tolerance for Transmit Spurious emissions	F	3.3.0	3.4.0	T1-010029
TP-11	TP-010019	061		CR on Test tolerance for Annex.F TS34.121	F	3.3.0	3.4.0	T1-010030
TP-11	TP-010019	062		CR on Test tolerance for 5.2 Maximum output power	F	3.3.0	3.4.0	T1-010031
TP-11	TP-010019	063		CR on Test tolerance for 5.4.3 Minimum Output Power	F	3.3.0	3.4.0	T1-010032
TP-11	TP-010019	064		CR on Test tolerance for 5.9 Spectrum Emission Mask	F	3.3.0	3.4.0	T1-010033
TP-11	TP-010019	065		CR on Test tolerance for 5.10 ACLR	F	3.3.0	3.4.0	T1-010034
TP-11	TP-010019	066		CR on Test tolerance for 5.12 Transmit Intermodulation	F	3.3.0	3.4.0	T1-010035
TP-11	TP-010019	067		CR on Test tolerance for 6.2 Reference Sensitivity Level	F	3.3.0	3.4.0	T1-010036
TP-11	TP-010019	068		CR on Test tolerance for 5.3 Frequency Error	F	3.3.0	3.4.0	T1-010037
TP-11	TP-010019	069		CR on Test tolerance for 5.8 Occupied Bandwidth	F	3.3.0	3.4.0	T1-010038
TP-11	TP-010019	070		CR on Test tolerance for 5.13.1 EVM	F	3.3.0	3.4.0	T1-010039
TP-11	TP-010019	071		CR on Test tolerance for 5.13.2 PCDE	F	3.3.0	3.4.0	T1-010040
TP-11	TP-010019	072		CR on Test tolerance for 5.4.4 Out of Synchronisation transmit power	F	3.3.0	3.4.0	T1-010041
TP-11	TP-010019	073		CR on Test tolerance for 6.4 ACS	F	3.3.0	3.4.0	T1-010042
TP-11	TP-010019	074		CR on Test tolerance for 6.8 RX Spurious Emissions	F	3.3.0	3.4.0	T1-010108
TP-11	TP-010019	075		CR on corrections to DL compressed mode	F	3.3.0	3.4.0	T1-010021
TP-11	TP-010019	076		CR on Corrections to DL 384kbps and BTFD measurement channels	F	3.3.0	3.4.0	T1-010022
TP-11	TP-010019	077		CR on Corrections to Maximum output power	F	3.3.0	3.4.0	T1-010023
TP-11	TP-010019	078		CR on RX spurious emissions	F	3.3.0	3.4.0	T1-010024
TP-11	TP-010019	079		CR on Editorial correction to channel number	D	3.3.0	3.4.0	T1-010026
TP-11	TP-010019	080		CR Correction of Annex-E and reference information to Annex E	F	3.3.0	3.4.0	T1-010043
TP-11	TP-010019	081		Editorial corrections	D	3.3.0	3.4.0	T1-010044
TP-11	TP-010076	082	1	Regional requirements on Test Tolerance	F	3.3.0	3.4.0	Presented directly to TP-11
TP-12	TP-010119	083		CR: Addition of Test System uncertainties and Test Tolerances	F	3.4.0	3.5.0	T1-010139
TP-12	TP-010119	084		CR: Measurement accuracy of CPICH RSCP	F	3.4.0	3.5.0	T1-010140
TP-12	TP-010119	085		CR: Measurement accuracy of CPICH Ec/Io	F	3.4.0	3.5.0	T1-010141
TP-12	TP-010119	086		CR: Modifications to the structure of RRM test cases (FDD)	F	3.4.0	3.5.0	T1-010142
TP-12	TP-010119	087		Maintenance CR: Propagation condition 250 km/h	F	3.4.0	3.5.0	T1-010143
TP-12	TP-010119	088		Maintenance CR: Removal of square brackets	F	3.4.0	3.5.0	T1-010144
TP-12	TP-010119	089		Maintenance CR: Tx power for Rx characteristics measurement	F	3.4.0	3.5.0	T1-010145
TP-12	TP-010119	090		Maintenance CR: Correction of Definition of multi-code OCNS signal	F	3.4.0	3.5.0	T1-010146
TP-12	TP-010119	091		Maintenance CR: Conformance requirement to Minimum requirement	D	3.4.0	3.5.0	T1-010147
TP-12	TP-010119	092		Maintenance CR: Test conditions for TS 34.121	F	3.4.0	3.5.0	T1-010148
TP-12	TP-010119	093		Maintenance CR: Editorial correction 34.121	D	3.4.0	3.5.0	T1-010149
TP-12	TP-010119	094		Maintenance CR: closed loop power control close to	C	3.4.0	3.5.0	T1-010150

T Meeting	Doc-1 st -Level	CR	Rev	Subject	Cat	Version - Current	Version -New	Doc-2 nd -Level
				the limits				
TP-12	TP-010119	095		Maintenance CR: removal of annex.I	D	3.4.0	3.5.0	T1-010151
TP-12	TP-010119	096		Maintenance CR: correction to annex.E	F	3.4.0	3.5.0	T1-010152
TP-12	TP-010119	097		Maintenance CR: corrections to TS34.121	F	3.4.0	3.5.0	T1-010153
TP-13	TP-010184	098		Annex F Measurement uncertainty	F	3.5.0	3.6.0	T1-010342
TP-13	TP-010184	099		RX Spurious emissions	F	3.5.0	3.6.0	T1-010364
TP-13	TP-010184	100		Structure of RRM test cases	F	3.5.0	3.6.0	T1-010356
TP-13	TP-010184	101		Clause 8.2, Idle mode cell reselection delay tests	F	3.5.0	3.6.0	T1-010361
TP-13	TP-010184	102		Proposal for measuring method of Random Access	F	3.5.0	3.6.0	T1-010362
TP-13	TP-010184	103		Modification to OCNS code channels to allow for 384 kbps allocation	F	3.5.0	3.6.0	T1-010339
TP-13	TP-010184	104		Clarification of AWGN definition	F	3.5.0	3.6.0	T1-010340
TP-13	TP-010184	105		Correction to test for inner loop power control in the uplink (FDD)	F	3.5.0	3.6.0	T1-010341
TP-13	TP-010184	106		Core specification change for uplink inner loop power control	F	3.5.0	3.6.0	T1-010355
TP-13	TP-010184	107		Power Control mode in downlink	F	3.5.0	3.6.0	T1-010357
TP-13	TP-010184	108		Correction of frequency range for receiver spurious emission requirements	F	3.5.0	3.6.0	T1-010360
TP-13	TP-010184	109		Test numbering of multi-path fading propagation tests	F	3.5.0	3.6.0	T1-010363
TP-13	TP-010184	110		Measurement of the ON/OFF power during the PRACH preamble	F	3.5.0	3.6.0	T1-010370
TP-14	TP-010259	111		Improvement of test description: CPICH RSCP test case	F	3.6.0	3.7.0	T1-010489
TP-14	TP-010259	112		Improvement of test description: CPICH Ec/Io test case	F	3.6.0	3.7.0	T1-010490
TP-14	TP-010259	113		UTRA Carrier RSSI test case	F	3.6.0	3.7.0	T1-010491
TP-14	TP-010259	114		Corrections and improvements for TS 34.121 subclauses 5, 6 and Annex E	F	3.6.0	3.7.0	T1-010492
TP-14	TP-010259	115		Clarification of test requirements for Transmit ON/OFF time mask	F	3.6.0	3.7.0	T1-010493
TP-14	TP-010259	116		Clarification of procedure for Out-of-synchronisation handling of output power	F	3.6.0	3.7.0	T1-010494
TP-14	TP-010259	117		UE Rx-Tx time difference type 1	F	3.6.0	3.7.0	T1-010495
TP-14	TP-010259	118		UE Transmit Timing	F	3.6.0	3.7.0	T1-010496
TP-14	TP-010259	119		Changes to blocking characteristics and spurious response test cases	F	3.6.0	3.7.0	T1-010497
TP-14	TP-010259	120		Clarification in Spectrum emission mask section	F	3.6.0	3.7.0	T1-010498
TP-14	TP-010259	121		DL Power Control Step Size in performance requirements	F	3.6.0	3.7.0	T1-010499
TP-14	TP-010259	122		DL Compressed mode, correction of pattern	F	3.6.0	3.7.0	T1-010500
TP-14	TP-010259	123		BER/BLER testing based on statistical approach	F	3.6.0	3.7.0	T1-010517
TP-14	TP-010259	124		Deletion of OFF power measurement on "Power setting in uplink compressed mode" Test	F	3.6.0	3.7.0	T1-010520
TP-14	TP-010259	125		Cell reselection delay tests in idle mode	F	3.6.0	3.7.0	T1-010521
TP-14	TP-010259	126		CR for Transmit OFF power measurement	F	3.6.0	3.7.0	T1-010522
TP-15	TP-020039	127		Correction of power terms and definitions	F	3.7.0	3.8.0	T1-020133
TP-15	TP-020039	128		Creation of common default messages for RRM test cases in Annex I	F	3.7.0	3.8.0	T1-020134
TP-15	TP-020039	129		Transmit ON/OFF time mask, Change of TFC and Power setting in uplink compressed mode	F	3.7.0	3.8.0	T1-020135
TP-15	TP-020039	130		Maintenance of Annex B	F	3.7.0	3.8.0	T1-020136
TP-15	TP-020039	131		Correction of minimum test times under fading	F	3.7.0	3.8.0	T1-020137
TP-15	TP-020039	132		Addition of test case description for SFN-CFN observed time difference	F	3.7.0	3.8.0	T1-020138
TP-15	TP-020039	133		Addition of test case description for SFN-SFN observed time difference type 1	F	3.7.0	3.8.0	T1-020139
TP-15	TP-020039	134		Corrections for TS 34.121 subclause 8.7.6	F	3.7.0	3.8.0	T1-020140
TP-15	TP-020039	135		Correction changes in clause 8.7	F	3.7.0	3.8.0	T1-020141
TP-15	TP-020039	136		Update of RRM Cell reselection delay tests in idle mode	F	3.7.0	3.8.0	T1-020142
TP-15	TP-020039	137		Implementation of test tolerances to test cases in subclause 7	F	3.7.0	3.8.0	T1-020143
TP-15	TP-020039	138		RRM AnnexF	F	3.7.0	3.8.0	T1-020144
TP-15	TP-020039	139		Connection Diagrams for RRM tests cell re-selection in idle mode	F	3.7.0	3.8.0	T1-020145
TP-15	TP-020039	140		Statistical testing of RRM delay performance	F	3.7.0	3.8.0	T1-020146
TP-15	TP-020039	141		RRM Hard handover test cases	F	3.7.0	3.8.0	T1-020147
TP-15	TP-020039	142		System Simulator and Test System definition	F	3.7.0	3.8.0	T1-020148
TP-15	TP-020039	143		WCDMA 1800 and 1900 additions	F	3.7.0	3.8.0	T1-020170

T Meeting	Doc-1 st -Level	CR	Rev	Subject	Cat	Version - Current	Version -New	Doc-2 nd -Level
TP-15	TP-020039	144		Correction of power spectral density	F	3.7.0	3.8.0	T1-020171
TP-16	TP-020139	145		Spectrum emission mask test case: Change to frequencies to be tested	F	3.8.0	3.9.0	T1-020220
TP-16	TP-020139	146		Power control in downlink, initial convergence	F	3.8.0	3.9.0	T1-020221
TP-16	TP-020139	147		Event triggered reporting in AWGN propagation conditions	F	3.8.0	3.9.0	T1-020222
TP-16	TP-020139	148		Event triggered reporting of multiple neighbours in AWGN propagation conditions	F	3.8.0	3.9.0	T1-020223
TP-16	TP-020139	149		Event triggered reporting of two detectable neighbours in AWGN propagation conditions	F	3.8.0	3.9.0	T1-020224
TP-16	TP-020139	150		Correct reporting of neighbours in fading propagation conditions	F	3.8.0	3.9.0	T1-020226
TP-16	TP-020139	151		Removal of "AFC On" reference from clause 5.3 Frequency Error test	F	3.8.0	3.9.0	T1-020227
TP-16	TP-020139	152		Correct reporting of neighbours in AWGN propagation conditions - inter frequency case	F	3.8.0	3.9.0	T1-020235
TP-16	TP-020139	153		Deletion of test case description 'Correct reporting of neighbours in Fading propagation conditions - Inter frequency case	F	3.8.0	3.9.0	T1-020236
TP-16	TP-020139	154		Correction of UE Tx Timing adjustment rate	F	3.8.0	3.9.0	T1-020237
TP-16	TP-020139	155		Correction of Units of side conditions and test parameters	F	3.8.0	3.9.0	T1-020238
TP-16	TP-020139	156		Structure of subclause 8	F	3.8.0	3.9.0	T1-020239
TP-16	TP-020139	157		Inter-system Handover from UTRAN FDD to GSM	F	3.8.0	3.9.0	T1-020240
TP-16	TP-020139	158		UTRAN to GSM Cell Re-Selection: Change of minimum requirements	F	3.8.0	3.9.0	T1-020241
TP-16	TP-020139	159		Cell reselection in idle mode: CR for testcase	F	3.8.0	3.9.0	T1-020242
TP-16	TP-020139	160		Cell reselection in idle mode: CR for annex F.4	F	3.8.0	3.9.0	T1-020243
TP-16	TP-020139	161		UTRAN to GSM cell reselection: CR for testcase	F	3.8.0	3.9.0	T1-020244
TP-16	TP-020139	162		UTRAN to GSM cell reselection: CR for annex F.4	F	3.8.0	3.9.0	T1-020245
TP-16	TP-020139	163		Test parameters of FDD/FDD Hard Handover test case	F	3.8.0	3.9.0	T1-020246
TP-16	TP-020139	164		Addition of details for RRM test cases in 8.3.7.1 and 8.3.7.2 (Cell Re-selection in URA_PCH)	F	3.8.0	3.9.0	T1-020247
TP-16	TP-020139	165		Addition of details for RRM test cases in 8.4.1 (RRC Re-establishment delay)	F	3.8.0	3.9.0	T1-020248
TP-16	TP-020139	166		Addition of details for RRM test case 8.3.1	F	3.8.0	3.9.0	T1-020249
TP-16	TP-020139	167		Addition of details for RRM test case 8.3.5.1	F	3.8.0	3.9.0	T1-020250
TP-16	TP-020139	168		Addition of details for RRM test case 8.3.5.2	F	3.8.0	3.9.0	T1-020251
TP-16	TP-020139	169		UE RX TX time difference: CR for testcase	F	3.8.0	3.9.0	T1-020252
TP-16	TP-020139	170		UE RX TX time difference: CR for annex	F	3.8.0	3.9.0	T1-020253
TP-16	TP-020139	171		Correction for SSDT test parameters and UL DPCCH slot format for performance	F	3.8.0	3.9.0	T1-020265
TP-16	TP-020139	172		Correction of UE FDD EVM definition	F	3.8.0	3.9.0	T1-020266
TP-16	TP-020139	173		Clarification of Meaning of FDR	F	3.8.0	3.9.0	T1-020267
TP-16	TP-020139	174		Modification to the test case for RX spurious emissions in TS34.121	F	3.8.0	3.9.0	T1-020268
TP-16	TP-020139	175		Editorial correction to Open Loop Power Control and Transmit ON/OFF Time mask in TS34.121	F	3.8.0	3.9.0	T1-020422
TP-16	TP-020139	176		Corrections to ACLR in TS34.121	F	3.8.0	3.9.0	T1-020423
TP-17	TP-020185	177	-	Addition of sub clause 8.7.6.2 – UE Rx-Tx time	F	3.9.0	3.10.0	T1-020453
TP-17	TP-020185	178	-	Addition of test case Cell reselection in CELL_PCH	F	3.9.0	3.10.0	T1-020454
TP-17	TP-020185	179	-	Addition of test case Transport format combination	F	3.9.0	3.10.0	T1-020455
TP-17	TP-020185	180	-	Maintenance of Re-selection and handover test	F	3.9.0	3.10.0	T1-020456
TP-17	TP-020185	181	-	Correction of test parameters of Handover to inter-	F	3.9.0	3.10.0	T1-020457
TP-17	TP-020185	182	-	Addition of details for RRM test case 8.7.3C (UE	F	3.9.0	3.10.0	T1-020458
TP-17	TP-020185	183	-	Corrections to clause 6 and 7 for editorial errors	F	3.9.0	3.10.0	T1-020459
TP-17	TP-020185	184	-	Correction to clause 8.2.2 Cell Re-Selection	F	3.9.0	3.10.0	T1-020460
TP-17	TP-020185	185	-	Correction to clause 8.3.1 FDD/FDD Soft Handover	F	3.9.0	3.10.0	T1-020461
TP-17	TP-020185	187	-	Correction to clause 8.6.1.1 Event triggered	F	3.9.0	3.10.0	T1-020463
TP-17	TP-020185	188	-	Correction to clause 8.6.1.2 Event triggered	F	3.9.0	3.10.0	T1-020464
TP-17	TP-020185	189	-	Correction to clause 8.6.1.3 Event triggered	F	3.9.0	3.10.0	T1-020465
TP-17	TP-020185	190	-	Correction to clause 8.6.1.4 Correct reporting of	F	3.9.0	3.10.0	T1-020466
TP-17	TP-020185	191	-	Correction to clause 8.6.2.1 Correct reporting of	F	3.9.0	3.10.0	T1-020467
TP-17	TP-020185	192	-	Correction to clause 8.7.1 CPICH RSCP	F	3.9.0	3.10.0	T1-020468
TP-17	TP-020185	193	-	Correction to clause 8.7.2 CPICH Ec/Io	F	3.9.0	3.10.0	T1-020469
TP-17	TP-020185	194	-	Correction of test case 'Rx-Tx time difference type	F	3.9.0	3.10.0	T1-020470

T Meeting	Doc-1 st -Level	CR	Rev	Subject	Cat	Version - Current	Version -New	Doc-2 nd -Level
TP-17	TP-020185	195	-	FDD/TDD Handover Test Case	F	3.9.0	3.10.0	T1-020471
TP-17	TP-020185	196	-	Test Requirements for Cell Re-Selection in	F	3.9.0	3.10.0	T1-020474
TP-17	TP-020185	197	-	Correction to clause 8.3.7 Cell Re-selection in	F	3.9.0	3.10.0	T1-020475
TP-17	TP-020185	198	-	Segmented Measurement to be allowed for Inner	F	3.9.0	3.10.0	T1-020476
TP-17	TP-020185	199	-	Correction to clause 8.4.1 RRC Re-establishment	F	3.9.0	3.10.0	T1-020477
TP-17	TP-020185	200	-	Correction to clause 8.7.3 UTRA Carrier RSSI	F	3.9.0	3.10.0	T1-020478
TP-17	TP-020185	201	-	Correction to clause 8.7.4 and 8.7.5 SFN-CFN/SFN	F	3.9.0	3.10.0	T1-020479
TP-17	TP-020185	202	-	Addition of a set of Compressed mode reference	F	3.9.0	3.10.0	T1-020480
TP-17	TP-020185	203	-	Correction of Compressed Mode Performance	F	3.9.0	3.10.0	T1-020481
TP-17	TP-020185	204	-	Tx Power level control during Rx testing	F	3.9.0	3.10.0	T1-020482
TP-17	TP-020185	205	-	Deletion of some suclauses from F.6.1 Statistical	F	3.9.0	3.10.0	T1-020483
TP-17	TP-020185	206	-	Correction to clause 8.3.5 Cell Re-selection in	F	3.9.0	3.10.0	T1-020484
TP-17	TP-020185	207	-	Test Requirements for Cell Re-Selection in CELL-	F	3.9.0	3.10.0	T1-020485
TP-17	TP-020185	208	-	Calculation of Test Requirements for Cell Re-	F	3.9.0	3.10.0	T1-020486
TP-17	TP-020185	209	-	Clarification of the definition of 90 % success rate	F	3.9.0	3.10.0	T1-020491
TP-17	TP-020185	210	-	Update of test requirement derivation of Downlink	F	3.9.0	3.10.0	T1-020492
TP-17	TP-020192	211	-	Correction of regional note in Annex J.1	F	3.9.0	3.10.0	-
TP-18	TP-020294	212	-	Correction of table titles of Demodulation of DCH in closed loop transmit diversity mode test case	F	3.10.0	3.11.0	T1-020631
TP-18	TP-020294	213	-	Maintenance of FDD/TDD Cell Re-selection test case	F	3.10.0	3.11.0	T1-020632
TP-18	TP-020294	214	-	Maintenance of UE Transmit Timing test case	F	3.10.0	3.11.0	T1-020633
TP-18	TP-020294	215	-	Correction of ACLR absolute power limit	F	3.10.0	3.11.0	T1-020634
TP-18	TP-020294	216	-	Correction to clause 8.3.6 Cell Re-selection in CELL_PCH	F	3.10.0	3.11.0	T1-020636
TP-18	TP-020294	217	-	Maintenance of 8.4.2.4 Correct behavior when reaching maximum transit power	F	3.10.0	3.11.0	T1-020637
TP-18	TP-020294	218	-	Correction of table numbers	F	3.10.0	3.11.0	T1-020639
TP-18	TP-020294	219	-	Correction of message parameter	F	3.10.0	3.11.0	T1-020640
TP-18	TP-020294	220	-	Correction of test parameter in 8.4.2.3 Correct behavior when Time-out	F	3.10.0	3.11.0	T1-020641
TP-18	TP-020294	221	-	Modification of the Random Access Test 8.4.2.1, Correct behaviour when receiving an ACK.	F	3.10.0	3.11.0	T1-020651
TP-18	TP-020294	222	-	Modifications to the test case for Inner Loop Power Control in the Uplink in TS34.121	F	3.10.0	3.11.0	T1-020642
TP-18	TP-020294	223	-	Correction of SCH side conditions and other corrections	F	3.10.0	3.11.0	T1-020750
TP-18	TP-020294	224	-	Corrections of test for power setting in uplink compressed mode	F	3.10.0	3.11.0	T1-020751
TP-18	TP-020294	225	-	Text for annex F.6.2 Statistical testing of RRM delay performance	F	3.10.0	3.11.0	T1-020752
TP-18	TP-020294	226	-	Maintenance of annex F.6.1 Statistical testing of BER BLER performance	F	3.10.0	3.11.0	T1-020753
TP-18	TP-020294	227	-	Dual limit BLER tests	F	3.10.0	3.11.0	T1-020754
TP-18	TP-020294	228	-	Correction of test method: Out-of-synchronisation handling of output power	F	3.10.0	3.11.0	T1-020755
TP-18	TP-020294	229	-	Correction of table and subclause references	F	3.10.0	3.11.0	T1-020756
TP-18	TP-020294	230	-	Revision of table titles in Sec 8. to provide unique and unambiguous descriptions	F	3.10.0	3.11.0	T1-020757
TP-18	TP-020294	231	-	Correction to clause 8.3.2 FDD/FDD Hard Handover	F	3.10.0	3.11.0	T1-020758
TP-18	TP-020294	232	-	Correction to PHYSICAL CHANNEL RECONFIGURATION message that activates compressed mode	F	3.10.0	3.11.0	T1-020759
TP-18	TP-020294	233	-	Introduction of test tolerances in Cell Reselection multi carrier test cases	F	3.10.0	3.11.0	T1-020769
TP-18	TP-020294	234	-	Correction of UL reference measurement channel	F	3.10.0	3.11.0	T1-020889
TP-19	TP-030045	235	-	P-CCPCH RSCP test case for FDD to TDD	F	3.11.0	3.12.0	T1-030171
TP-19	TP-030045	236	-	Correct reporting of TDD inter-frequency neighbours	F	3.11.0	3.12.0	T1-030172
TP-19	TP-030045	237	-	Correction for minimum requirement of UE	F	3.11.0	3.12.0	T1-030173
TP-19	TP-030045	238	-	Removal of 34.123-1 Annex A reference	F	3.11.0	3.12.0	T1-030174
TP-19	TP-030045	239	-	Correction of UE parameter for Correct behaviour at	F	3.11.0	3.12.0	T1-030175
TP-19	TP-030045	240	-	Correction of Out-of-synchronisation handling of	F	3.11.0	3.12.0	T1-030178
TP-19	TP-030045	241	-	Removal of uplink dummy DCCH transmission	F	3.11.0	3.12.0	T1-030179
TP-19	TP-030045	242	-	Correction for Combining of TPC commands from	F	3.11.0	3.12.0	T1-030186
TP-20	TP-030099	243	-	Modifications to the test cases for Transmit diversity	F	3.12.0	3.13.0	T1-030323

T Meeting	Doc-1 st -Level	CR	Rev	Subject	Cat	Version - Current	Version -New	Doc-2 nd -Level
				modes in TS34.121				
TP-20	TP-030099	244	-	Correction for Cell Re-selection in CELL_FACH state test case	F	3.12.0	3.13.0	T1-030324
TP-20	TP-030099	245	-	Correction for Random Access test case	F	3.12.0	3.13.0	T1-030325
TP-20	TP-030099	246	-	Correction for downlink compressed mode test case	F	3.12.0	3.13.0	T1-030326
TP-20	TP-030099	247	-	CR to 34.121 R99; Correction to Activation Time in Hard Handover RRM Test Cases	F	3.12.0	3.13.0	T1-030343
TP-20	TP-030099	249	-	CR to 34.121 R99; Correction to Inner Loop Power Control in the Uplink	F	3.12.0	3.13.0	T1-030348
TP-20	-	-	-	Upgrade to Rel-4	-	3.13.0	4.0.0	-
TP-20	TP-030099	250	-	Addition of clarification for modulation accuracy requirement	F	4.0.0	5.0.0	T1-030732
TP-21	TP-030189	251	-	Creation of a merged release for 34.121 which incorporates R99 and Rel-4	F	5.0.0	5.1.0	T1-030796
TP-21	TP-030189	253	-	CR to 34.121 R99; Addition of test case details for RRM test case 8.3.5.3 (Cell Reselection to GSM in Cell_FACH)	F	3.13.0	5.1.0	T1-030814
TP-21	TP-030189	254	-	CR to 34.121 REL-4; Addition of test case details for RRM test case 8.3.5.3 (Cell Reselection to GSM in Cell_FACH)	A	4.0.0	5.1.0	T1-030815
TP-21	TP-030189	255	-	CR to 34.121 REL-5; Addition of test case details for RRM test case 8.3.5.3 (Cell Reselection to GSM in Cell_FACH)	A	5.0.0	5.1.0	T1-030816
TP-21	TP-030189	256	-	Correction of SSdT performance test case (R99)	F	3.13.0	5.1.0	T1-030817
TP-21	TP-030189	257	-	Correction of SSdT performance test case (Rel-4)	A	4.0.0	5.1.0	T1-030818
TP-21	TP-030189	258	-	Correction of SSdT performance test case (Rel-5)	A	5.0.0	5.1.0	T1-030819
TP-21	TP-030189	261	-	Test Requirements for RRM CPICH RSCP Inter Frequency Measurement	F	3.13.0	5.1.0	T1-030841
TP-21	TP-030189	262	-	Test Requirements for RRM CPICH RSCP Inter Frequency Measurement	A	4.0.0	5.1.0	T1-030842
TP-21	TP-030189	263	-	Test Requirements for RRM CPICH RSCP Inter Frequency Measurement	A	5.0.0	5.1.0	T1-030843
TP-21	TP-030189	264	-	Test Requirements for RRM CPICH RSCP Intra Frequency Measurement	F	3.13.0	5.1.0	T1-030859
TP-21	TP-030189	265	-	Test Requirements for RRM CPICH RSCP Intra Frequency Measurement	A	4.0.0	5.1.0	T1-030860
TP-21	TP-030189	266	-	Test Requirements for RRM CPICH RSCP Intra Frequency Measurement	A	5.0.0	5.1.0	T1-030861
TP-21	TP-030189	267	-	Correction to RRC Re-establishment delay test case (R99)	F	3.13.0	5.1.0	T1-030862
TP-21	TP-030189	268	-	Correction to RRC Re-establishment delay test case (Rel-4)	A	4.0.0	5.1.0	T1-030863
TP-21	TP-030189	269	-	Correction to RRC Re-establishment delay test case (Rel-5)	A	5.0.0	5.1.0	T1-030864
TP-21	TP-030189	270	-	CR to 34.121 R99; Correction to SFN-SFN observed time difference type 1	F	3.13.0	5.1.0	T1-030865
TP-21	TP-030189	271	-	CR to 34.121 Rel-4; Correction to SFN-SFN observed time difference type 1	A	4.0.0	5.1.0	T1-030866
TP-21	TP-030189	272	-	CR to 34.121 Rel-5; Correction to SFN-SFN observed time difference type 1	A	5.0.0	5.1.0	T1-030867
TP-21	TP-030189	277	-	CR to 34.121 R99; Correction to CPICH Ec/Io in correct reporting of neighbours in AWGN propagation condition test case	F	3.13.0	5.1.0	T1-031108
TP-21	TP-030189	278	-	CR to 34.121 Rel-4; Correction to CPICH Ec/Io in correct reporting of neighbours in AWGN propagation condition test case	4	4.0.0	5.1.0	T1-031109
TP-21	TP-030189	279	-	CR to 34.121 Rel-5; Correction to CPICH Ec/Io in correct reporting of neighbours in AWGN propagation condition test case	A	5.0.0	5.1.0	T1-031110
TP-21	TP-030189	280	-	Test Requirements for RRM CPICH Ec/Io Intra Frequency Measurement	F	3.13.0	5.1.0	T1-031182
TP-21	TP-030189	281	-	Test Requirements for RRM CPICH Ec/Io Intra Frequency Measurement	A	4.0.0	5.1.0	T1-031183
TP-21	TP-030189	282	-	CR Rel 5 Test requirements for RRM CPICH_Ec/Io Intra Frequency Measurement	A	5.0.0	5.1.0	T1-031184
TP-21	TP-030189	283	-	Test Requirements for RRM CPICH Ec/Io Inter Frequency Measurement	F	3.13.0	5.1.0	T1-031188
TP-21	TP-030189	284	-	Test Requirements for RRM CPICH Ec/Io Inter Frequency Measurement	A	4.0.0	5.1.0	T1-031189
TP-21	TP-030189	285	-	Test Requirements for RRM CPICH Ec/Io Inter Frequency Measurement	A	5.0.0	5.1.0	T1-031190
TP-21	TP-030189	286	-	Test requirements for RRM Random Access tests	F	3.13.0	5.1.0	T1-031191

T Meeting	Doc-1 st -Level	CR	Rev	Subject	Cat	Version - Current	Version -New	Doc-2 nd -Level
TP-21	TP-030189	287	-	Test requirements for RRM Random Access Test	A	4.0.0	5.1.0	T1-031192
TP-21	TP-030189	288	-	Test requirements for RRM Random Access Test	A	5.0.0	5.1.0	T1-031193
TP-21	TP-030189	289	-	Completion of Annex F	F	3.13.0	5.1.0	T1-031229
TP-21	TP-030189	290	-	Completion of Annex F	A	4.0.0	5.1.0	T1-031230
TP-21	TP-030189	291	-	Completion of Annex F	A	5.0.0	5.1.0	T1-031231
TP-21	TP-030189	252	-	CR to 34.121 R99; Corretion to Inter-system Handover from UTRAN FDD to GSM	F	3.13.0	5.1.0	T1-030800
TP-21	TP-030189	273	-	CR to 34.121 Rel-99; Correction to CRC bit for reference measurement channel using RLC-TM for DTCH, transport channel parameters	F	3.13.0	5.1.0	T1-030870
TP-21	TP-030189	274	-	Introduction of Test Tolerances to Cell Reselection in CELL_FACH tests 8.3.5.1 & 8.3.5.2	F	3.13.0	5.1.0	T1-030873
TP-21	TP-030189	259	-	Introduction of Test Tolerances to Cell Reselection in CELL_FACH tests 8.3.5.1 & 8.3.5.2	F	4.0.0	5.1.0	T1-030832
TP-21	TP-030189	260	-	Introduction of Test Tolerances to Cell Reselection in CELL_FACH tests 8.3.5.1 & 8.3.5.2	F	5.0.0	5.1.0	T1-030833
TP-21	TP-030189	275	-	CR to 34.121 Rel-4; Corretion to Inter-system Handover from UTRAN FDD to GSM	F	4.0.0	5.1.0	T1-031103
TP-21	TP-030189	276	-	CR to 34.121 Rel-5; Corretion to Inter-system Handover from UTRAN FDD to GSM	F	5.0.0	5.1.0	T1-031104
TP-21	TP-030189	292	-	CR to 34.121 Rel-4; Correction to CRC bit for reference measurement channel using RLC-TM for DTCH, transport channel parameters	F	4.0.0	5.1.0	T1-030871
TP-21	TP-030189	293	-	CR to 34.121 Rel-5; Correction to CRC bit for reference measurement channel using RLC-TM for DTCH, transport channel parameters	F	5.0.0	5.1.0	T1-030872
TP-21	TP-030189	296	-	Introduction of the phase discontinuity test (Specific to Rel-5)	F	5.0.0	5.1.0	T1-031277
				Complete CR266 implementation		5.1.0	5.1.1	
TP-22	TP-030280	298		CR to 34.121: Correction to Inter-system Handover from UTRAN FDD to GSM	F	5.1.1	5.2.0	T1-031356
TP-22	TP-030280	299		CR to 34.121: Correction to Power control in DL, initial convergence test case	F	5.1.1	5.2.0	T1-031357
TP-22	TP-030280	319		Correction to RRM test case 8.3.2.1	F	5.1.1	5.2.0	T1-031445
TP-22	TP-030280	314	1	Correction of clause 4.2 Frequency bands	B	5.1.1	5.2.0	T1-031551
TP-22	TP-030280	315	1	Clause 4.4 Channel arrangement for DS-CDMA Introduction in the 800 MHz Band	B	5.1.1	5.2.0	T1-031552
TP-22	TP-030280	316	1	DS-CDMA Introduction in the 800 MHz Band	B	5.1.1	5.2.0	T1-031553
TP-22	TP-030280	317	1	Correction and maintenance of Annex H and DS-CDMA Introduction in the 800 MHz Band	B	5.1.1	5.2.0	T1-031556
TP-22	TP-030280	300	1	Introduction of reference to RRM test tolerances TR	F	5.1.1	5.2.0	T1-031561
TP-22	TP-030280	301	1	Introduction of Test Tolerances to Cell Reselection tests 8.2.2.1 & 8.2.2.2	F	5.1.1	5.2.0	T1-031562
TP-22	TP-030280	302	1	Introduction of Test Tolerances to Cell Re-selection in CELL_PCH tests 8.3.6.1 & 8.3.6.2	F	5.1.1	5.2.0	T1-031563
TP-22	TP-030280	329		Introduction of Test Tolerances to Cell Re-selection in URA_PCH tests 8.3.7.1 & 8.3.7.2	F	5.1.1	5.2.0	T1-031564
TP-22	TP-030280	303	1	Clarification of Downlink Physical Channel in table E.3.1	F	5.1.1	5.2.0	T1-031565
TP-22	TP-030280	309	1	FDD inter-frequency cell identification and measurement reporting test case	F	5.1.1	5.2.0	T1-031566
TP-22	TP-030280	310	1	Changes to section 8.4.3, TFC selection requirements for codec mode switch	F	5.1.1	5.2.0	T1-031567
TP-22	TP-030280	327	1	Test requirements for RRM CPICH RSCP Intra Frequency Measurement	F	5.1.1	5.2.0	T1-031568
TP-22	TP-030280	328	1	Test requirements for RRM CPICH RSCP Inter Frequency Measurement	F	5.1.1	5.2.0	T1-031569
TP-22	TP-030280	324	1	Test requirements for RRM CPICH_Ec/Io Intra Frequency Measurement	F	5.1.1	5.2.0	T1-031570
TP-22	TP-030280	325	1	Test requirements for RRM CPICH_Ec/Io Inter Frequency Measurement	F	5.1.1	5.2.0	T1-031571
TP-22	TP-030280	318	1	Correction of clause 8.7.3C UE transmitted power	F	5.1.1	5.2.0	T1-031604
TP-22	TP-030280	304	1	CR to 34.121: Correction to FDD/FDD Soft Handover test case	F	5.1.1	5.2.0	T1-031605
TP-22	TP-030280	308	1	Correction to RRM test case 8.3.5.3	F	5.1.1	5.2.0	T1-031606
TP-22	TP-030280	321	1	12.2 kbit/s RMC is insufficient for BLER testing	F	5.1.1	5.2.0	T1-031611
TP-22	TP-030280	320	1	Update of initial conditions for RF test cases	F	5.1.1	5.2.0	T1-031612
TP-22	TP-030280	307	2	Addition of two new test cases; 7.11 (Demodulation of paging channel (PCH)) and 7.12 (Detection of acquisition indicator (AI)).	F	5.1.1	5.2.0	T1-031613
TP-22	TP-030280	311	1	Performance requirement for HSDPA skeleton	F	5.1.1	5.2.0	T1-031624

T Meeting	Doc-1 st -Level	CR	Rev	Subject	Cat	Version - Current	Version -New	Doc-2 nd -Level
				section added				
TP-22	TP-030280	312	1	New test requirements for Demodulation of HS-DSCH (fixed reference channel) single link performance	F	5.1.1	5.2.0	T1-031625
TP-22	TP-030280	313	1	New test requirements for reporting of HS-DSCH Channel Quality Indicator (CQI) AWGN propagation conditions	F	5.1.1	5.2.0	T1-031626
TP-22	TP-030280	306	1	Correction to F.1.5 Requirements for support of RRM	F	5.1.1	5.2.0	T1-031627
TP-22	TP-030280	331		Correction to W-CDMA modulated interferer definition	F	5.1.1	5.2.0	T1-031652
TP-22	TP-030280	330	1	Correction on Random Access test cases	F	5.1.1	5.2.0	T1-031692
TP-22	TP-030280	332		Addition to Scope clause to clarify applicability of tests to Releases	F	5.1.1	5.2.0	T1-031694
TP-23	TP-040038	332	-	Introduction of Test Tolerance to Maximum Input Level test 6.3	F	5.2.0	5.3.0	T1-040099
TP-23	TP-040038	333	-	CPICH_Ec/Io Inter frequency relative accuracy requirements for reported values.	F	5.2.0	5.3.0	T1-040165
TP-23	TP-040038	334	-	Correction to the measurement control message in 8.7.2.	F	5.2.0	5.3.0	T1-040288
TP-23	TP-040038	335	-	Correction of the TGD value for single gap transmission gap pattern	F	5.2.0	5.3.0	T1-040289
TP-23	TP-040038	336	-	Correction to the Measurement Control message in 8.7.6 UE Rx-Tx time difference	F	5.2.0	5.3.0	T1-040292
TP-23	TP-040038	337	-	Introduction of correct reporting of GSM neighbours in AWGN propagation condition test case	F	5.2.0	5.3.0	T1-040341
TP-23	TP-040038	338	-	Correction to 8.6.2.1 Correct reporting of neighbours in AWGN propagation condition	F	5.2.0	5.3.0	T1-040345
TP-23	TP-040038	339	-	Correction to RRC connection control test 1 and 2	F	5.2.0	5.3.0	T1-040354
TP-23	TP-040038	340	-	Correction of measurement control message in inter frequency measurement test cases.	F	5.2.0	5.3.0	T1-040100
TP-23	TP-040038	341	-	Correction to W-CDMA modulated interferer definition	F	5.2.0	5.3.0	T1-040190
TP-23	TP-040038	342	-	Removal of square brackets in Annex F.6	F	5.2.0	5.3.0	T1-040248
TP-23	TP-040038	343	-	Excess test uncertainties	F	5.2.0	5.3.0	T1-040279
TP-23	TP-040038	344	-	Define TBD message parameters for FDD/FDD Hard Handover test cases	F	5.2.0	5.3.0	T1-040281
TP-23	TP-040038	345	-	Introduction of Test Tolerances to FDD/FDD Hard Handover to intra-frequency cell, test 8.3.2.1	F	5.2.0	5.3.0	T1-040282
TP-23	TP-040038	346	-	Introduction of Test Tolerances to FDD/FDD Hard Handover to inter-frequency cell, test 8.3.2.2	F	5.2.0	5.3.0	T1-040284
TP-23	TP-040038	347	-	Introduction of PRACH preamble tests	B	5.2.0	5.3.0	T1-040330
TP-23	TP-040038	348	-	Correction of requirements of HSDPA CQI reporting in AWGN propagation conditions	F	5.2.0	5.3.0	T1-040333
TP-23	TP-040038	349	-	Annex A for HSDPA	F	5.2.0	5.3.0	T1-040337
TP-23	TP-040038	350	-	Annex F.1 for HSDPA	F	5.2.0	5.3.0	T1-040338
TP-23	TP-040038	351	-	Correction of DL channelisation code value in DL radio resources	F	5.2.0	5.3.0	T1-040339
TP-23	TP-040038	352	-	Correction to F.4.1	F	5.2.0	5.3.0	T1-040393
TP-23	TP-040038	353	-	Links to Annex F.6.2 in RRM test cases	F	5.2.0	5.3.0	T1-040139
TP-23	TP-040038	354	-	Clarify measurement control for FDD/FDD Inter-frequency Hard Handover test case	F	5.2.0	5.3.0	T1-040252
TP-23	-	-	-	Correction on implementation of CR 333 on CPICH_Ec/Io Inter frequency relative accuracy requirements for reported values.on Table 8.7.2.2.3	F	5.3.0	5.3.1	-
TP-24	TP-040113	355	-	Introduction of Test Tolerances to Event triggered reporting in AWGN propagation conditions, test 8.6.1.1	F	5.3.1	5.4.0	T1-040524
TP-24	TP-040113	356	-	Corrections to CPICH RSCP test cases	F	5.3.1	5.4.0	T1-040533
TP-24	TP-040113	357	-	Corrections to CPICH Ec/Io test cases	F	5.3.1	5.4.0	T1-040534
TP-24	TP-040113	358	-	Correction to 8.4.1.1 RRC cnnction control test 1	F	5.3.1	5.4.0	T1-040864
TP-24	TP-040113	359	-	Correction to MEASUREMENT CONTROL and MEASUREMENT REPORT messages	F	5.3.1	5.4.0	T1-040541
TP-24	TP-040113	360	-	Addition of unit for OCNS_Ec/Ior in RRM tests	F	5.3.1	5.4.0	T1-040542
TP-24	TP-040113	361	-	Correction to default messages in Annex I of 34.121	F	5.3.1	5.4.0	T1-040591
TP-24	TP-040113	362	-	Update of F1.5	F	5.3.1	5.4.0	T1-040695
TP-24	TP-040113	363	-	Correction of Spurious Emissions for UMTS800(band VI)	F	5.3.1	5.4.0	T1-040700
TP-24	TP-040113	364	-	Removal of [] for UE transmit power test case 8.7.3C	F	5.3.1	5.4.0	T1-040720
TP-24	TP-040113	365	-	Correction to 8.7.6 UE Rx-Tx time difference	F	5.3.1	5.4.0	T1-040728
TP-24	TP-040113	366	-	Inter system handover	F	5.3.1	5.4.0	T1-040805

T Meeting	Doc-1 st -Level	CR	Rev	Subject	Cat	Version - Current	Version -New	Doc-2 nd -Level
TP-24	TP-040113	367	-	Correction to BTFD test case 7.10	F	5.3.1	5.4.0	T1-040815
TP-24	TP-040113	368	-	Addition of details for RRM test case for GSM carrier RSSI	F	5.3.1	5.4.0	T1-040816
TP-24	TP-040113	369	-	Correction of FDD intra frequency measurements , wrong IEs	F	5.3.1	5.4.0	T1-040817
TP-24	TP-040113	370	-	Correction of FDD inter frequency measurements, wrong IEs	F	5.3.1	5.4.0	T1-040818
TP-24	TP-040113	371	-	Correction to Transmit Off Power	F	5.3.1	5.4.0	T1-040824
TP-24	TP-040113	372	-	Corrections to UTRA Carrier RSSI test cases	F	5.3.1	5.4.0	T1-040825
TP-24	TP-040113	373	-	Corrections to FDD/FDD Soft Handover test cases	F	5.3.1	5.4.0	T1-040826
TP-24	TP-040113	374	-	Correction to the pathloss indicator in measurement control messages	F	5.3.1	5.4.0	T1-040827
TP-24	TP-040113	375	-	Corrections to SFN-CFN observed time difference test cases	F	5.3.1	5.4.0	T1-040831
TP-24	TP-040113	376	-	Corrections to SFN-SFN type 1 measurement test cases	F	5.3.1	5.4.0	T1-040832
TP-24	TP-040113	377	-	Correction to URA identity for reselection in Cell URA_PCH	F	5.3.1	5.4.0	T1-040834
TP-24	TP-040113	378	-	Proposed addition of downlink code allocation table to 34.121 Annex	F	5.3.1	5.4.0	T1-040838
TP-24	TP-040113	379	-	Correction of channel number for UMTS800(band VI)	F	5.3.1	5.4.0	T1-040839
TP-24	TP-040113	380	-	Correction to the pathloss indicator in measurement control messages	F	5.3.1	5.4.0	T1-040840
TP-24	TP-040113	381	-	HSDPA test 9.3.1	F	5.3.1	5.4.0	T1-040842
TP-24	TP-040113	382	-	HSDPA test 9.3.2	F	5.3.1	5.4.0	T1-040843
TP-24	TP-040113	383	-	New test case for 9.2.2 Open Loop Diversity Performance	F	5.3.1	5.4.0	T1-040844
TP-24	TP-040113	385	-	Statistical approach for HSDPA tests	F	5.3.1	5.4.0	T1-040854
TP-24	TP-040113	386	-	Correction to GSM neighbour reporting in 8.6.4.1	F	5.3.1	5.4.0	T1-040856
TP-24	TP-040113	387	-	Correction to measurement report in 8.3.2	F	5.3.1	5.4.0	T1-040857
TP-24	TP-040113	388	-	Corrections to UE Rx-Tx time difference type 1 test cases	F	5.3.1	5.4.0	T1-040859
TP-24	TP-040113	389	-	Addition of MEASUREMENT CONTROL message and ACTIVESET UPDATE message in 8.5.1	F	5.3.1	5.4.0	T1-040863
TP-24	TP-040113	391	-	HSDPA test: 9.2.1	F	5.3.1	5.4.0	T1-040871
TP-24	TP-040113	392	-	New test case for 9.4 HS-SCCH Detection Performance	F	5.3.1	5.4.0	T1-040872
TP-24	TP-040113	393	-	New TPC combining in SHO	F	5.3.1	5.4.0	T1-040873
TP-24	TP-040113	394	-	New test case for 9.2.3 Closed Loop Diversity Performance	F	5.3.1	5.4.0	T1-040874
TP-24	TP-040113	395	-	Addition of CELL_UPDATE CONFIRM Message and URA_UPDATE CONFIRM Message.	F	5.3.1	5.4.0	T1-040866
TP-24	TP-040113	396	-	Correction to 7.11 (Demodulation of paging channel (PCH))	F	5.3.1	5.4.0	T1-040855
TP-25	TP-040158	395	-	Addition of a new case to Adjacent Channel Selectivity test	F	5.4.0	5.5.0	T1-041017
TP-25	TP-040158	396	-	Removal of [] for test case 8.3.5.3 'Cell Reselection to GSM'	D	5.4.0	5.5.0	T1-041034
TP-25	TP-040158	397	-	Addition of the integrity protection in messages	F	5.4.0	5.5.0	T1-041058
TP-25	TP-040158	398	-	Correction to Cell Re-selection in CELL_PCH and URA_PCH test cases	F	5.4.0	5.5.0	T1-041076
TP-25	TP-040158	399	-	Addition of test tolerances to TC 8.4.3	F	5.4.0	5.5.0	T1-041093
TP-25	TP-040158	400	-	Revision of Test Tolerances to Event triggered reporting in AWGN propagation conditions, test 8.6.1.1	F	5.4.0	5.5.0	T1-041098
TP-25	TP-040158	401	-	Correction of RRM test case 8.7.3A (GSM carrier RSSI)	F	5.4.0	5.5.0	T1-041176
TP-25	TP-040158	402	-	Completion of Annex F.6.3 Statistical Testing of HSDPA Receiver Performance	F	5.4.0	5.5.0	T1-041201
TP-25	TP-040158	403	-	Correction to the Measurement Control message in 8.7.6 UE Rx-Tx time difference	F	5.4.0	5.5.0	T1-041203
TP-25	TP-040158	404	-	Correction to the pathloss indicator in measurement control messages	F	5.4.0	5.5.0	T1-041204
TP-25	TP-040158	405	-	Correction to test uncertainty definition of Inner Loop Power Control in the Uplink test case	F	5.4.0	5.5.0	T1-041307
TP-25	TP-040158	406	-	Addition of the integrity protection in 5.7 Power setting in uplink compressed mode	F	5.4.0	5.5.0	T1-041308
TP-25	TP-040158	407	-	Corrections to Demodulation of DCH in Inter-Cell Soft Handover	B	5.4.0	5.5.0	T1-041311
TP-25	TP-040158	408	-	Correction to 7.7.3: Combining of reliable TPC commands from radio links of different radio link sets	F	5.4.0	5.5.0	T1-041314

T Meeting	Doc-1 st -Level	CR	Rev	Subject	Cat	Version - Current	Version -New	Doc-2 nd -Level
TP-25	TP-040158	409	-	Addition of TPC error rate accuracy to TC 7.7.3	F	5.4.0	5.5.0	T1-041316
TP-25	TP-040158	410	-	Test system uncertainties update for test case 8.3.5.3	F	5.4.0	5.5.0	T1-041319
TP-25	TP-040158	411	-	Corrections to UTRA Carrier RSSI test case	F	5.4.0	5.5.0	T1-041325
TP-25	TP-040158	412	-	Resolution of downlink code conflict between OCNS DPCH and S-CCPCH	F	5.4.0	5.5.0	T1-041326
TP-25	TP-040158	413	-	Addition of the information element for monitor cells in Annex I	F	5.4.0	5.5.0	T1-041328
TP-25	TP-040158	414	-	Correction to 5.5.2: Transmit ON/OFF Time mask test case	F	5.4.0	5.5.0	T1-041333
TP-25	TP-040158	415	-	Cell configuration mapping	F	5.4.0	5.5.0	T1-041341
TP-25	TP-040158	416	-	Test tolerances in 8.4.1 RRC Re-establishment delay	F	5.4.0	5.5.0	T1-041344
TP-25	TP-040158	417	-	Completion of Transmitter Intermodulation test 5.12	F	5.4.0	5.5.0	T1-041345
TP-25	TP-040158	418	-	Correction of reference to generic setup procedure in TS 34.108 for Cell_FACH	F	5.4.0	5.5.0	T1-041348
TP-25	TP-040158	419	-	Correction to TC 7.8.3, Power control in the downlink, wind up effects	F	5.4.0	5.5.0	T1-041349
TP-25	TP-040158	420	-	Revision of Receiver Spurious Emissions Test 6.8	F	5.4.0	5.5.0	T1-041353
TP-25	TP-040158	421	-	Correction to BTFD test case 7.10 and DL dummy DCCH	F	5.4.0	5.5.0	T1-041358
TP-25	TP-040158	422	-	Correction to measurement control message in 8.6.1.2	F	5.4.0	5.5.0	T1-041360
TP-25	TP-040158	423	-	Correction to test case 8.2.3 'UTRAN to GSM Cell Re-Selection'	F	5.4.0	5.5.0	T1-041362
TP-25	TP-040158	425	-	Corrections to Annex F.2.4 and F.4.4	F	5.4.0	5.5.0	T1-041322
TP-25	TP-040158	426	-	Introduction of Test Tolerances to Event triggered reporting of multiple neighbours in AWGN propagation condition, test 8.6.1.2	F	5.4.0	5.5.0	T1-041329
TP-25	TP-040158	427	-	Correction to 8.6.1.1	F	5.4.0	5.5.0	T1-041361
TP-25	TP-040158	429	-	Proposed addition of HSDPA downlink code allocation to 34.121 Annex	F	5.4.0	5.5.0	T1-041372
TP-25	TP-040158	430	-	Maximum Input Level for HSDPA	F	5.4.0	5.5.0	T1-041375
TP-25	TP-040158	431	-	Correction to test procedure for test cases using Cell_PCH or URA_PCH state	F	5.4.0	5.5.0	T1-041347r2
TP-25	TP-040158	432	-	Clarification of OCNS power control	F	5.4.0	5.5.0	T1-041318r4
TP-26	TP-040234	433	-	Addition of UMTS-850 Band V to chapter 5	F	5.5.0	5.6.0	T1-041524
TP-26	TP-040234	434	-	Correction of the FDD/FDD Soft Handover test parameters	F	5.5.0	5.6.0	T1-041567
TP-26	TP-040234	435	-	Corrections to TC 8.7.3C UE transmitted power	F	5.5.0	5.6.0	T1-041577
TP-26	TP-040234	436	-	Addition of test tolerances to TC 8.3.4	F	5.5.0	5.6.0	T1-041579
TP-26	TP-040234	437	-	New clause for reference conditions	F	5.5.0	5.6.0	T1-041648
TP-26	TP-040234	438	-	Alignment of HSDPA OCNS with TS 25.101	F	5.5.0	5.6.0	T1-041650
TP-26	TP-040234	439	-	Correction to Handover to GSM TC 8.3.4	F	5.5.0	5.6.0	T1-041653
TP-26	TP-040234	440	-	Correction to test procedure in 7.12	F	5.5.0	5.6.0	T1-041661
TP-26	TP-040234	441	-	Correction to 8.7.6.1 UE Rx-Tx time difference type 1	F	5.5.0	5.6.0	T1-041662
TP-26	TP-040234	442	-	Corrections to RRM test cases 8.6.1.2 Event triggered reporting...	F	5.5.0	5.6.0	T1-041667
TP-26	TP-040234	443	-	Update of references to GSM core specifications	F	5.5.0	5.6.0	T1-041684
TP-26	TP-040234	444	-	Corrections to HSDPA test 9.4 (HS-SCCH detection)	F	5.5.0	5.6.0	T1-041749
TP-26	TP-040234	445	-	Clarification of HS-PDSCH and HS-SCCH signal structure	F	5.5.0	5.6.0	T1-041790
TP-26	TP-040234	446	-	CR to 34.121 Rel 5: Editorial corrections to test 8.7.3	D	5.5.0	5.6.0	T1-041810
TP-26	TP-040234	447	-	Corrections to BTFD test case	F	5.5.0	5.6.0	T1-041813
TP-26	TP-040234	448	-	Corrections to RRM test cases 8.3.2.1 and 8.3.2.2 Correction to the test procedure of FDD/FDD Hard Handover test cases	F	5.5.0	5.6.0	T1-041818
TP-26	TP-040234	449	-	Corrections to TC 8.6.4.1	F	5.5.0	5.6.0	T1-041822
TP-26	TP-040234	450	-	Correction to pathloss indicator	F	5.5.0	5.6.0	T1-041824
TP-26	TP-040234	451	-	Corrections to RRM test case 8.5.1 UE Transmit Timing	F	5.5.0	5.6.0	T1-041830
TP-26	TP-040234	452	-	Corrections and additions to Release 5 RRM test case 8.6.2.2	F	5.5.0	5.6.0	T1-041831
TP-26	TP-040234	453	-	Measurement Channel for BLER measurement in 8.3.1 FDD/FDD Soft Handover.	F	5.5.0	5.6.0	T1-041832
TP-26	TP-040234	454	-	Correction to SFN-SFN observed time difference type 1 measurement test case	F	5.5.0	5.6.0	T1-041834
TP-26	TP-040234	455	-	Corrections to HSDPA test 6.3A (max input power)	F	5.5.0	5.6.0	T1-041838
TP-26	TP-040234	456	-	CM configuration in FDD inter frequency measurements in TC 8.6.2.1	F	5.5.0	5.6.0	T1-041841

T Meeting	Doc-1 st -Level	CR	Rev	Subject	Cat	Version - Current	Version -New	Doc-2 nd -Level
TP-26	TP-040234	457	-	Addition of the scheduling information for Cell Re-Selection test cases	F	5.5.0	5.6.0	T1-041843
TP-26	TP-040234	458	-	Correction to 8.3.1 UE FDD/FDD Soft Handover	F	5.5.0	5.6.0	T1-041844
TP-26	TP-040234	459	-	Correction to 8.7.1.1 CPICH RSCP Intra frequency measurements accuracy	F	5.5.0	5.6.0	T1-041845
TP-26	TP-040234	460	-	Corrections to HSDPA test 9.3 (CQI reporting)	F	5.5.0	5.6.0	T1-041852
TP-26	TP-040234	461	-	Correction to measurement configurations in section 7	F	5.5.0	5.6.0	T1-041858
TP-26	TP-040234	462	-	Change of notes position in TS34.121 Annex E.3	F	5.5.0	5.6.0	T1-041859
TP-26	TP-040234	463	-	BLER testing for UEs with asymmetrical UL/DL data rates	F	5.5.0	5.6.0	T1-041860
TP-26	TP-040234	464	-	Invalid MAC header for downlink dummy DCCH	F	5.5.0	5.6.0	T1-041861
TP-26	TP-040234	465	-	Addition of test tolerances and corrections for 8.6.2.1 Correct reporting of neighbours in AWGN propagation condition (34.121)	F	5.5.0	5.6.0	T1-041865
TP-26	TP-040234	466	-	Correction to Correct reporting of neighbours in fading propagation condition test case	F	5.5.0	5.6.0	T1-041866
TP-26	TP-040234	467	-	Correction to Event triggered reporting of two detectable neighbours in AWGN propagation condition test cases	F	5.5.0	5.6.0	T1-041867
TP-26	TP-040234	468	-	S-CCPCH configuration in 8.3.5 Cell Re-selection in CELL_FACH.	F	5.5.0	5.6.0	T1-041868
TP-26	TP-040234	469	-	Corrections to TC 8.2.3.1 and 8.2.3.2	F	5.5.0	5.6.0	T1-041869
TP-26	TP-040234	470	-	Correction to MEASUREMENT CONTROL Message for 8.6.2.1: Correct reporting of neighbours in AWGN propagation condition and 8.3.2.2: FDD/FDD Hard Handover to inter-frequency cell test cases	F	5.5.0	5.6.0	T1-041870
TP-26	TP-040234	471	-	Corrections to HSDPA test 9.2 (Demod of HS-DSCH)	F	5.5.0	5.6.0	T1-041872
TP-26	TP-040234	472	-	Addition of UMTS-850 Band V to chapter 6	F	5.5.0	5.6.0	T1-041873
TP-26	TP-040234	473	-	Correction of time to receive system information in RRM test cases	F	5.5.0	5.6.0	T1-041877
TP-26	TP-040234	474	-	CR to 34.121: Changing the BLER target for the DCCH in test 7.8	D	5.5.0	5.6.0	T1-041878
TP-26	TP-040234	475	-	Corrections to Information elements for Monitored Cells in Annex I.	F	5.5.0	5.6.0	T1-041881
TP-26	TP-040234	476	-	Introduction of UMTS-850 MHz band V	F	5.5.0	5.6.0	T1-041882
TP-26	TP-040234	477	-	Introduction of Test Tolerances to Event triggered reporting of multiple neighbours in AWGN propagation condition (Rel-4 and later), test 8.6.1.2A	F	5.5.0	5.6.0	T1-041507
TP-26	TP-040234	478	-	Addition of UMTS-850 Band V to chapter 4.	F	5.5.0	5.6.0	T1-041523

T Meeting	Doc-1 st -Level	CR	Rev	Subject	Cat	Version - Current	Version -New	Doc-2 nd -Level
TP-27	TP-050033	479		Change of test method and test time optimization in TC 8.7.3A	F	5.6.0	6.0.0	T1-050080
TP-27	TP-050033	480		Corrections to RRM test case 8.4.3.1 "Transport format combination selection in UE"	F	5.6.0	6.0.0	T1-050122
TP-27	TP-050033	481		lor value correction for RRM test case, 8.6.2.1	F	5.6.0	6.0.0	T1-050124
TP-27	TP-050033	482		Removal of editorial notes from TC 8.7.3C	F	5.6.0	6.0.0	T1-050186
TP-27	TP-050033	483		Invalid MAC header for downlink dummy DCCH (mandatory)	F	5.6.0	6.0.0	T1-050215
TP-27	TP-050033	484		Correction to RRC CONNECTION SETUP and RB SETUP messages for TX diversity	F	5.6.0	6.0.0	T1-050217
TP-27	TP-050033	485		Correction to CPICH_Ec/Io in 8.6.1.3	F	5.6.0	6.0.0	T1-050219
TP-27	TP-050033	486		Correction to "Read SFN indicator" in Measurement Control Messages	F	5.6.0	6.0.0	T1-050221
TP-27	TP-050033	487		Table E.3.4 Correction	D	5.6.0	6.0.0	T1-050233
TP-27	TP-050033	488		Addition of 25.212 to reference list	D	5.6.0	6.0.0	T1-050234
TP-27	TP-050033	489		Addition of fading case 8 for HSDPA testing	D	5.6.0	6.0.0	T1-050235
TP-27	TP-050033	490		Measurement configuration setup information	F	5.6.0	6.0.0	T1-050308
TP-27	TP-050033	491		Addition of uncertainties and test tolerances to TC 7.7.3	F	5.6.0	6.0.0	T1-050309
TP-27	TP-050033	492		Omission of test points in 6.5. Blocking Characteristics	F	5.6.0	6.0.0	T1-050311
TP-27	TP-050033	493		CR to 34.121: Changes to 7.12: Detection of Acquisition Indicator	F	5.6.0	6.0.0	T1-050313
TP-27	TP-050033	494		CR to 34.121: Changes to 8.6.1.2 Event triggered reporting of multiple neighbours in AWGN propagation condition (R99)	F	5.6.0	6.0.0	T1-050315
TP-27	TP-050033	495		Deletion of Target quality value on DTCH in Clause 8.7.3C UE transmitted power	F	5.6.0	6.0.0	T1-050316
TP-27	TP-050033	496		Clarification of reference value for T Reconfirm Abort Parameter in Inter-Rat Test Case 8.3.4	F	5.6.0	6.0.0	T1-050319
TP-27	TP-050033	497		Clarification of RRM TC 8.2.3	F	5.6.0	6.0.0	T1-050321
TP-27	TP-050033	498		Correction to "Reporting cell status" in Measurement Control Messages	F	5.6.0	6.0.0	T1-050322
TP-27	TP-050033	499		Correction to 8.3.1	F	5.6.0	6.0.0	T1-050324
TP-27	TP-050033	500		Correction to MEASUREMENT REPORT message in Annex I	F	5.6.0	6.0.0	T1-050326
TP-27	TP-050033	501		Removal of Rel-5 specific reference to TS 25.101	F	5.6.0	6.0.0	T1-050329
TP-27	TP-050033	502		Test tolerances for Test 9.2.2 Open loop diversity performance and 9.2.3 Closed loop diversity performance	F	5.6.0	6.0.0	T1-050338
TP-27	TP-050033	503		CR to 34.121: Changes to Annex D and Annex H to introduce UMTS 850 Band	B	5.6.0	6.0.0	T1-050347
TP-27	TP-050033	504		Correction of 34.121 Power vs. Time diagrams	F	5.6.0	6.0.0	T1-050351
TP-27	TP-050033	505		Clarification for Test Case 7.9	F	5.6.0	6.0.0	T1-050352
TP-27	TP-050033	506		Correction to OCNS value in 8.7.2.2	F	5.6.0	6.0.0	T1-050356
TP-27	TP-050033	508		Level Definition HS_SCCH_1 and DPCH for Test 9.2.2 Open loop diversity performance And Test 9.2.3 Closed loop diversity performance	F	5.6.0	6.0.0	T1-050362
TP-27	TP-050033	509		Changes to Annex I to harmonise System Information scheduling for RRM test cases.	F	5.6.0	6.0.0	T1-050366
TP-27	TP-050033	510		Level Definition HS_SCCH_1 and DPCH for Test 9.2.1 Single link performance	F	5.6.0	6.0.0	T1-050368
TP-27	TP-050033	511		Correction to TS34.121 TC 8.4.2	D	5.6.0	6.0.0	T1-050370
TP-27	TP-050033	512		Correction to the event triggered reporting test cases	F	5.6.0	6.0.0	T1-050371
TP-27	TP-050033	513		Corrections to reporting of CQI	F	5.6.0	6.0.0	T1-050373
TP-27	TP-050033	514		Correction to H Set-4/5 pattern length	F	5.6.0	6.0.0	T1-050374
TP-27	TP-050033	515		Corrections to detection of HS-SCCH	F	5.6.0	6.0.0	T1-050375
TP-27	TP-050033	516		CR to 34.121 section 5: Introduction of test case for Adjacent Channel Leakage Power Ratio with HS-DPCCH	B	5.6.0	6.0.0	T1-050376
TP-27	TP-050033	517		CR to 34.121 section 5: Introduction of new test case for HSDPA: UE max output power with HS-DPCCH	B	5.6.0	6.0.0	T1-050377
TP-27	TP-050033	518		CR to 34.121 section 5: Introduction of new test case for Error Vector Magnitude with HS-DPCCH	B	5.6.0	6.0.0	T1-050378
TP-27	TP-050033	519		CR to 34.121 section 5: Introduction of a new test case for spectrum emission mask with HS-DPCCH	B	5.6.0	6.0.0	T1-050379
TP-27	TP-050033	520		CR to 34.121: Changes to RRM test cases for introduction of UMTS 850 Band	B	5.6.0	6.0.0	T1-050381
TP-27	TP-050033	521		Corrections to maximum input level for HS-PDSCH reception	F	5.6.0	6.0.0	T1-050382
TP-27	TP-050033	522		Corrections to TC 8.5.1 UE transmit timing	F	5.6.0	6.0.0	T1-050318r3

T Meeting	Doc-1 st -Level	CR	Rev	Subject	Cat	Version - Current	Version -New	Doc-2 nd -Level
TP-27	TP-050033	523		Corrections to demodulation of HS-DSCH	F	5.6.0	6.0.0	T1-050383
RP-28	RP-050269	525	-	CR to 34.121: Correction to operating conditions for TCs: 5.13.1, 5.13A.1 & 5.13.2	F	6.0.0	6.1.0	R5-050671
RP-28	RP-050269	526	-	Removal of TGPL2	F	6.0.0	6.1.0	R5-050842
RP-28	RP-050269	527	-	Clarification of the interfering signal in 6.5 Blocking Characteristics and 6.7 Intermodulation Characteristics	F	6.0.0	6.1.0	R5-050816
RP-28	RP-050269	528	-	Addition of test tolerances to TC 7.11	F	6.0.0	6.1.0	R5-050615
RP-28	RP-050269	529	-	Correction to 7.7.2 Combining of TPC commands from radio links of different radio link sets	F	6.0.0	6.1.0	R5-050820
RP-28	RP-050269	530	-	Clarification of TS34.121 Closed Loop Transmit Diversity test cases	F	6.0.0	6.1.0	R5-050833
RP-28	RP-050269	531	-	CR to 34.121: Clarification of Annex C.6 for BLER measurement configurations	F	6.0.0	6.1.0	R5-050843
RP-28	RP-050269	532	-	Change of 34.121 test case 7.8.2	F	6.0.0	6.1.0	R5-050850
RP-28	RP-050269	533	-	Correction to TS34.121 TC 8.6.1.2	F	6.0.0	6.1.0	R5-050571
RP-28	RP-050269	534	-	Correction to TS34.121 TC 8.7.6.1	F	6.0.0	6.1.0	R5-050573
RP-28	RP-050269	535	-	Corrections to test cases having power control ON.	F	6.0.0	6.1.0	R5-050652
RP-28	RP-050269	536	-	Correction to TS34.121 TC 8.6.1.3	F	6.0.0	6.1.0	R5-050822
RP-28	RP-050269	537	-	Modification of call setup procedure for inter-RAT connected state RRM tests	F	6.0.0	6.1.0	R5-050823
RP-28	RP-050269	538	-	Addition of test tolerances and corrections for 8.6.2.2 Correct reporting of neighbours in fading propagation condition	F	6.0.0	6.1.0	R5-050825
RP-28	RP-050269	539	-	CR to 34.121: GSM band corrections	F	6.0.0	6.1.0	R5-050829
RP-28	RP-050269	540	-	Statistical approach for 8.7.3A GSM Carrier RSSI	F	6.0.0	6.1.0	R5-050837
RP-28	RP-050269	541	-	CR to 34.121 Rel-6; Update of the MEASUREMENT REPORT message to RRC release 5	F	6.0.0	6.1.0	R5-050821
RP-28	RP-050269	542	-	CR to 34.121: Corrections to Annex C and Annex E	F	6.0.0	6.1.0	R5-050830
RP-28	RP-050269	543	-	CR to TC 5.9 Spectrum emission mask	F	6.0.0	6.1.0	R5-050814
RP-28	RP-050269	544	-	Clarifications of TS34.121 section 9.1	F	6.0.0	6.1.0	R5-050575
RP-28	RP-050270	545	-	Editorial correction to TS34.121 TC 9.3.2	D	6.0.0	6.1.0	R5-050718
RP-28	RP-050270	546	-	CR to 34.121: Addition of a new annex section for uplink Reference Measurement Channel for testing of UE Transmitter Characteristics with HS-DPCCH.	F	6.0.0	6.1.0	R5-050841
RP-28	RP-050270	547	-	CR to 34.121: New test case for HS-DPCCH.	F	6.0.0	6.1.0	R5-050860
RP-28	RP-050270	548	-	Correction to 9.2.1 Single Link Performance in 9.2 Demodulation of HS-DSCH	F	6.0.0	6.1.0	R5-050864
RP-28	RP-050270	549	-	Corrections to TC 7.12, detection of acquisition indicator (AI)	F	6.0.0	6.1.0	R5-050819
RP-28	RP-050270	550	-	Corrections to test tolerances in TC 7.8.2	F	6.0.0	6.1.0	R5-050847
RP-28	RP-050270	551	-	OCNS for TX diversity	F	6.0.0	6.1.0	R5-050859
RP-28	RP-050270	552	-	Correction to "Read SFN indicator" in Measurement Control Messages in 8.3.2.2	F	6.0.0	6.1.0	R5-050863
RP-28	RP-050270	553	-	Corrections to TC 5.4.1 and 5.5.2 due to too low S-CCPCH level	F	6.0.0	6.1.0	R5-050614
RP-28	RP-050270	554	-	Changes to 8.3.1 FDD/FDD Soft Handover.	F	6.0.0	6.1.0	R5-050877
RP-29	RP-050517	555	-	Addition of test tolerances to open loop power control tolerance	F	6.1.0	6.2.0	R5-051155
RP-29	RP-050517	556	-	Correction to 5.13.3	F	6.1.0	6.2.0	R5-051282
RP-29	RP-050517	557	-	Correction of Transmit ON/OFF Test Case 5.5.2	F	6.1.0	6.2.0	R5-051405
RP-29	RP-050517	558	-	Clarification to TX OFF power Test Tolerance in TC 5.5.2	F	6.1.0	6.2.0	R5-051406
RP-29	RP-050517	559	-	Correction to 5.6	F	6.1.0	6.2.0	R5-051408
RP-29	RP-050517	560	-	Correction to 34.121 for test case: 5.7 Power setting in uplink compressed mode	F	6.1.0	6.2.0	R5-051412
RP-29	RP-050517	561	-	Correction to 5.3 Frequency Error	F	6.1.0	6.2.0	R5-051440
RP-29	RP-050517	562	-	Output power control in the uplink procedure changes (TC5.4.1)	F	6.1.0	6.2.0	R5-051441
RP-29	RP-050517	563	-	Correction to 5.4.1 and 5.5.2	F	6.1.0	6.2.0	R5-051442
RP-29	RP-050517	564	-	Correction to 5.11	F	6.1.0	6.2.0	R5-051453
RP-29	RP-050517	565	-	CR to 34.121: Correction to TC 7.11 PCH detection regarding SIB5	F	6.1.0	6.2.0	R5-051117
RP-29	RP-050517	566	-	Corrections to Procedure and Test System Uncertainty for TC7.7.3	F	6.1.0	6.2.0	R5-051444
RP-29	RP-050517	567	-	Correction to UE parameters for AI test	F	6.1.0	6.2.0	R5-051452
RP-29	RP-050517	568	-	CR on 34.121: Correction to TC 8.3.3	F	6.1.0	6.2.0	R5-051099
RP-29	RP-050517	569	-	Removal of TC 8.6.1.4 Correct reporting of neighbours in fading propagation condition	F	6.1.0	6.2.0	R5-051159
RP-29	RP-050517	570	-	Removal of TC 8.7.3.2 from R99, Rel-4 and Rel-5	F	6.1.0	6.2.0	R5-051160
RP-29	RP-050517	571	-	CR to 34.121: Correction to RXLEV in test	F	6.1.0	6.2.0	R5-051193

T Meeting	Doc-1 st -Level	CR	Rev	Subject	Cat	Version - Current	Version -New	Doc-2 nd -Level
				requirements for cell re-selection to GSM test cases				
RP-29	RP-050517	572	-	Correction to 8.3.5.2	F	6.1.0	6.2.0	R5-051275
RP-29	RP-050517	573	-	Correction to "Reporting cell status" in Measurement Control Messages	F	6.1.0	6.2.0	R5-051276
RP-29	RP-050517	574	-	CR to 34.121: Addition of SFN-SFN type 2 and RX-TX type 2 measurement requirements	F	6.1.0	6.2.0	R5-051417
RP-29	RP-050518	575	-	Correction to procedure for RRM test case 8.3.5.3	F	6.1.0	6.2.0	R5-051418
RP-29	RP-050518	576	-	Update of Annex I and K	F	6.1.0	6.2.0	R5-051421
RP-29	RP-050518	577	-	Correction / Clarification to Annex E Transmit Diversity	F	6.1.0	6.2.0	R5-051416
RP-29	RP-050518	578	-	Feature Clean Up: Removal of Closed Loop mode 2	F	6.1.0	6.2.0	R5-051072
RP-29	RP-050518	579	-	Feature Clean Up: Removal of DRAC from TS 34.121	F	6.1.0	6.2.0	R5-051422
RP-29	RP-050518	580	-	Feature Clean Up: Removal of Observed Time Difference to GSM cell from TS 34.121	F	6.1.0	6.2.0	R5-051423
RP-29	RP-050518	581	-	Feature Clean Up: Removal of SSdT from TS 34.121	F	6.1.0	6.2.0	R5-051424
RP-29	RP-050518	582	-	Feature Clean Up: Removal of compressed mode by puncturing	F	6.1.0	6.2.0	R5-051425
RP-29	RP-050518	583	-	Feature Clean Up: Removal of DSCH	F	6.1.0	6.2.0	R5-051426
RP-29	RP-050518	584	-	Feature Clean Up to 34.121: Removal of CPCH	F	6.1.0	6.2.0	R5-051447
RP-29	RP-050518	585	-	Correction to Annex F for 6.3A Maximum Input Level for HS-PDSCH Reception	F	6.1.0	6.2.0	R5-051278
RP-29	RP-050518	586	-	Correction to 9.2.3 Closed Loop Diversity Performance	F	6.1.0	6.2.0	R5-051279
RP-29	RP-050518	587	-	Correction to 5.9A Spectrum Emission Mask with HS-DPCCH	F	6.1.0	6.2.0	R5-051429
RP-29	RP-050513	588	-	Correction to 34.121 for HSDPA test case: Maximum Output Power with HS-DPCCH and addition of Uplink Reference Measurement Channel for testing	F	6.1.0	6.2.0	R5-051431
RP-29	RP-050518	589	-	Table C.8.1.5 Correction	F	6.1.0	6.2.0	R5-051433
RP-29	RP-050518	590	-	Correction to 5.10A ACLR with HS-DPCCH	F	6.1.0	6.2.0	R5-051449
RP-29	RP-050513	591	-	Correction to 34.121 for HSDPA test case 5.7A: HS-DPCCH	F	6.1.0	6.2.0	R5-051450
RP-29	RP-050518	592	-	Removal of 1st BLER measurement in TC 7.8.1 and 7.9.1	F	6.1.0	6.2.0	R5-051438
RP-29	RP-050518	593	-	Corrections and Clarification of TC8.6.4.1	F	6.1.0	6.2.0	R5-051589
RP-29	RP-050518	594	-	Corrections to Inter-system handover TC 8.3.4	F	6.1.0	6.2.0	R5-051590
RP-30	RP-050767	595	-	Correction to 34.121 for HSDPA test case 5.7A: HS-DPCCH	F	6.2.0	6.3.0	R5-051921
RP-30	RP-050767	596	-	Correction to 34.121: UE Capabilities for HSDPA testing	F	6.2.0	6.3.0	R5-052341
RP-30	RP-050767	597	-	Correction to power step size for HSDPA test case 5.7A: HS-DPCCH	F	6.2.0	6.3.0	R5-051927
RP-30	RP-050716	598	-	Addition of reference measurement channel for E-DCH RF testing	F	6.2.0	6.3.0	R5-052327
RP-30	RP-050719	599	-	Restructuring of chapter 9.4 (HS-SCCH detection performance)	F	6.2.0	6.3.0	R5-052333
RP-30	RP-050719	600	-	Addition of HSDPA Enhanced performance requirements plus splitting of Test Cases in Sections 9.2.1, 9.2.2 and 9.2.3	B	6.2.0	6.3.0	R5-052343
RP-30	RP-050767	601	-	Addition of Open and Closed loop diversity Rel-6 test cases for CQI reporting in section 9.3 and calculation of BLER during CQI reporting tests	B	6.2.0	6.3.0	R5-052318
RP-30	RP-050770	602	-	Modification of the protection band for PHS	F	6.2.0	6.3.0	R5-051994
RP-30	RP-050770	603	-	Revision of additional receiver spurious emissions requirements on 800MHz band in Japan	F	6.2.0	6.3.0	R5-051995
RP-30	RP-050770	604	-	Clarification of UE measurement reference point	F	6.2.0	6.3.0	R5-052305
RP-30	RP-050770	605	-	Addition of test tolerance to Change of TFC Test Case	F	6.2.0	6.3.0	R5-051843
RP-30	RP-050770	606	-	Addition of test tolerance to Power setting in Uplink compressed mode Test Case	F	6.2.0	6.3.0	R5-052303
RP-30	RP-050770	607	-	Correction to TC5.4.1 and 5.5.2 <REFlor> and levels	F	6.2.0	6.3.0	R5-052304
RP-30	RP-050770	608	-	Correction to TS34.121 TC7.7.3	F	6.2.0	6.3.0	R5-051844
RP-30	RP-050770	609	-	Correction to Measurement Configuration in TS34.121 Chapter 7	F	6.2.0	6.3.0	R5-052309
RP-30	RP-050770	610	-	Clarification on TFCS size for DCH demodulation requirements	F	6.2.0	6.3.0	R5-051934
RP-30	RP-050770	611	-	Correction to TC7.7.2 statistical requirements	F	6.2.0	6.3.0	R5-052306
RP-30	RP-050776	612	-	Test time optimization for test cases 7.11 and 7.12	F	6.2.0	6.3.0	R5-052022

T Meeting	Doc-1 st -Level	CR	Rev	Subject	Cat	Version - Current	Version -New	Doc-2 nd -Level
RP-30	RP-050770	613	-	Modification of BLER target in RRM hard handover test cases	F	6.2.0	6.3.0	R5-051853
RP-30	RP-050770	614	-	Removal of some event 1C reporting which may fill RLC buffer in RRM testcases 8.6.1.2 and 8.6.1.2A	F	6.2.0	6.3.0	R5-052310
RP-30	RP-050770	615	-	Correction to 8.2.3.1 and 8.2.3.2 Monitored cell list information added	F	6.2.0	6.3.0	R5-052338
RP-30	RP-050770	616	-	Correction to 8.3.1 Test procedure	F	6.2.0	6.3.0	R5-052312
RP-30	RP-050770	617	-	Clarification of monitored cell list	F	6.2.0	6.3.0	R5-052336
RP-30	RP-050770	618	-	Correction to 8.3.7 Cell Re-selection in URA_PCH	F	6.2.0	6.3.0	R5-052007
RP-30	RP-050770	619	-	Addition of integrity check info in MEASUREMENT CONTROL messages	F	6.2.0	6.3.0	R5-052314
RP-30	RP-050777	620	-	Correction to SIB 11 of 8.6.2.2 in Annex I	F	6.2.0	6.3.0	R5-052315
RP-30	RP-050779	621	-	New test scenario: 8.2.3.3 Scenario 3: HCS with only UTRA level changed.	F	6.2.0	6.3.0	R5-052347
RP-30	RP-050779	622	-	Introduction of PRACH timing accuracy test	F	6.2.0	6.3.0	R5-052337
RP-30	RP-050770	623	-	Correction to Measurement Report messages	F	6.2.0	6.3.0	R5-052344
RP-30	RP-050770	624	-	Corrections to Annex F for Change of TFC	F	6.2.0	6.3.0	R5-052316
RP-30	RP-050770	625	-	Removal of temporary BLER measurement configuration	F	6.2.0	6.3.0	R5-051935
RP-30	RP-050780	626	-	Introduction of UMTS1700 for TS34.121	B	6.2.0	6.3.0	R5-052334
RP-31	RP-060144	627	-	Introduction of test case 5.9B Spectrum Emission Mask with E-DCH	F	6.3.0	6.4.0	R5-060465
RP-31	RP-060155	628	-	Allowance of alternative DL power control response time	D	6.3.0	6.4.0	R5-060466
RP-31	RP-060153	629	-	Introduction of Band VII and Band VIII to Chapter 5	F	6.3.0	6.4.0	R5-060427
RP-31	RP-060155	630	-	Allowance of DL power control response time in TC 7.8.2	F	6.3.0	6.4.0	R5-060114
RP-31	RP-060155	631	-	Correction to SIB11 signaling for interfrequency test cases	F	6.3.0	6.4.0	R5-060464
RP-31	RP-060144	632	-	Introduction of test case 5.10B Adjacent Channel Leakage Ratio (ACLR) with E-DCH	F	6.3.0	6.4.0	R5-060456
RP-31	RP-060155	633	-	Correction to tolerance of setting -20 dBm output power in tests 5.13.1 and 5.13.2	F	6.3.0	6.4.0	R5-060458
RP-31	RP-060155	634	-	Correction to spurious emissions requirements in TC 5.11	F	6.3.0	6.4.0	R5-060461
RP-31	RP-060155	635	-	Clarification of Connection Diagrams in Annex A	F	6.3.0	6.4.0	R5-060452
RP-31	RP-060166	636	-	New Rel-6 RRM test case for combined inter-frequency and GSM measurements	F	6.3.0	6.4.0	R5-060460
RP-31	RP-060155	637	-	Alignment of 34.121 and 25.133 for TC 8.4.1.2	F	6.3.0	6.4.0	R5-060421
RP-31	RP-060153	638	-	Introduction of UMTS band VII and VIII test cases for TS34.121 chapter 8 and annex D	F	6.3.0	6.4.0	R5-060428
RP-31	RP-060146	639	-	Correction to Performance requirements for HSDPA in Clause 9	F	6.3.0	6.4.0	R5-060243
RP-31	RP-060146	640	-	Correction to 34.121 for HSDPA: UE max output power with HS-DPCCH	F	6.3.0	6.4.0	R5-060426
RP-31	RP-060151	641	-	Correction to Annex F Statistical Requirements for HSDPA tests	F	6.3.0	6.4.0	R5-060425
RP-31	RP-060146	642	-	Correction to TRANSPORT CHANNEL RECONFIGURATION message for test cases with HSDPA	F	6.3.0	6.4.0	R5-060423
RP-31	RP-060146	643	-	Missing references and definitions for performance requirements for HSDPA	F	6.3.0	6.4.0	R5-060417
RP-31	RP-060146	644	-	Definition of downlink power level for HSDPA RF transmitter test cases	F	6.3.0	6.4.0	R5-060416
RP-31	RP-060146	645	-	Addition of Test System Uncertainties for 9.3.x	F	6.3.0	6.4.0	R5-060411
RP-31	RP-060155	646	-	Correction to monitored cell lists	F	6.3.0	6.4.0	R5-060420
RP-31	RP-060155	647	-	Clarification of CN domain for BLER measurements	F	6.3.0	6.4.0	R5-060261
RP-31	RP-060164	648	-	Editorial errors and missing changes in Section 9 and related annexes	F	6.3.0	6.4.0	R5-060409
RP-31	RP-060155	649	-	Correction to 7.7.3 Combining of reliable TPC commands from radio links of different radio link sets	F	6.3.0	6.4.0	R5-060246
RP-31	RP-060155	650	-	Correction to TC7.7.2 power step threshold	F	6.3.0	6.4.0	R5-060407
RP-31	RP-060155	651	-	Editorial errors in Clause 5	D	6.3.0	6.4.0	R5-060403
RP-31	RP-060155	652	-	Band IX additions to tables 5.4.1.3 and 5.5.2.3	F	6.3.0	6.4.0	R5-060408
RP-31	RP-060144	653	-	Code allocation for EDCH testing	F	6.3.0	6.4.0	R5-060437
RP-31	RP-060163	654	-	Correction to 34.121: FDD/TDD Cell Re-selection, TDD measurements and P-CCPCH RSCP test cases	F	6.3.0	6.4.0	R5-060441
RP-31	RP-060155	655	-	Detection and measurements of new cells not belonging to monitored set	F	6.3.0	6.4.0	R5-060418
RP-31	RP-060152	656	-	Introduction of Band VII and Band VIII to Chapter 6	F	6.3.0	6.4.0	R5-060040
RP-31	RP-060152	657	-	Introduction of Band VII and Band VIII to Chapter 4	F	6.3.0	6.4.0	R5-060038

T Meeting	Doc-1 st -Level	CR	Rev	Subject	Cat	Version - Current	Version -New	Doc-2 nd -Level
				and introduction of new UARFCN scheme				
RP-31	RP-060146	658	-	Correction to HSDPA call setup levels in 34.121	F	6.3.0	6.4.0	R5-060297
RP-31	RP-060155	659	-	Corrections to downlink code allocation tables in Annex E.6	F	6.3.0	6.4.0	R5-060046
RP-31	RP-060163	660	-	Clarifications to TC 8.6.1.4A	F	6.3.0	6.4.0	R5-060288
RP-31	RP-060155	661	-	Correction to 8.7.4.2 Inter frequency measurement requirement	F	6.3.0	6.4.0	R5-060242
RP-31	RP-060163	662	-	Correction to MEASUREMENT CONTROL message in 8.6.1.2A	F	6.3.0	6.4.0	R5-060241
RP-31	RP-060155	663	-	Correction to 8.3.2.2 FDD/FDD Hard Handover to inter-frequency cell	F	6.3.0	6.4.0	R5-060240
RP-31	RP-060155	664	-	Change to the statistical analysis of multiple events in 8.6.x.x. tests	F	6.3.0	6.4.0	R5-060047
RP-31	RP-060163	665	-	Correction to 7.12	F	6.3.0	6.4.0	R5-060239
RP-31	RP-060155	666	-	Correction to 7.8.2	F	6.3.0	6.4.0	R5-060238
RP-31	RP-060155	667	-	Correction of TGD parameter for compressed mode tests	F	6.3.0	6.4.0	R5-060237
RP-31	RP-060155	668	-	Correction to Frequency Error	F	6.3.0	6.4.0	R5-060235
RP-31	RP-060155	669	-	Correction to the operating conditions in TS34.121 5.13.1 and 5.13.1A	F	6.3.0	6.4.0	R5-060043
RP-31	RP-060144	670	-	Correction to 34.121: HSDPA and E-DCH beta configurations	F	6.3.0	6.4.0	R5-060468
RP-31	RP-060146	671	-	Correction of HSDPA EVM test case 5.13.1A	F	6.3.0	6.4.0	R5-060590
RP-31	RP-060164	672	-	New Test Case Introduction to 34.121: Power control in the downlink, different transport formats	F	6.3.0	6.4.0	R5-060588
RP-31	RP-060166	673	-	Replace the content of 34.121 with reference pointer to Version 7.0.0	F	6.3.0	6.4.0	R5-060557
RP-31	RP-060167	674	-	Convert 34.121 to a multipart specification; 34.121-1 modification	F	6.3.0	7.0.0	R5-060574
RP-32	RP-060322	675	-	Correction to test system uncertainty in 5.11	F	7.0.0	7.1.0	R5-061402
RP-32	RP-060322	676	-	Correction to spurious emissions requirements applicability for TC 5.11	F	7.0.0	7.1.0	R5-061209
RP-32	RP-060329	677	-	Correction to 5.13.3	F	7.0.0	7.1.0	R5-061456
RP-32	RP-060322	678	-	Clarification to TC7.8.2	F	7.0.0	7.1.0	R5-061404
RP-32	RP-060322	679	-	Correction to TC7.9	F	7.0.0	7.1.0	R5-061405
RP-32	RP-060322	680	-	Correction to 7.8.1 and 7.9.1 test cases	F	7.0.0	7.1.0	R5-061406
RP-32	RP-060329	681	-	Correction to 34.121-1 Test Case 7.8.4: Power control in the downlink, different transport formats	F	7.0.0	7.1.0	R5-061407
RP-32	RP-060328	682	-	Missing lor/loc field in 7.12 test requirements	F	7.0.0	7.1.0	R5-061408
RP-32	RP-060331	683	-	Modifications to 8.6.5 Combined Interfrequency and GSM measurements	F	7.0.0	7.1.0	R5-061409
RP-32	RP-060329	684	-	Correction to Measurement Control Message in 8.6.2.2	F	7.0.0	7.1.0	R5-061411
RP-32	RP-060322	685	-	correction to Tc 8.7.3.a	F	7.0.0	7.1.0	R5-061412
RP-32	RP-060322	686	-	Tc 8.7.3a - Move Sib 11 exceptions to Annex I	F	7.0.0	7.1.0	R5-061413
RP-32	RP-060322	687	-	Tc 8.3.5.3 - Addition of 2quarter parameters to the test parameters	F	7.0.0	7.1.0	R5-061414
RP-32	RP-060322	688	-	Addition of measurement performance requirements for Band III/IX UE	F	7.0.0	7.1.0	R5-061416
RP-32	RP-060322	689	-	Correction to the contents of Tables of the section of F.4 of 3GPP TS 34.121-1	F	7.0.0	7.1.0	R5-061457
RP-32	RP-060322	690	-	Correction to Annex F.6.1.10 Dual limit BLER tests	F	7.0.0	7.1.0	R5-061458
RP-32	RP-060328	691	-	Addition of downlink physical channels power definition for performance tests without a dedicated connection	F	7.0.0	7.1.0	R5-061423
RP-32	RP-060337	692	-	Clarification to H-SET 1 used in Tx HSDPA tests	F	7.0.0	7.1.0	R5-061428
RP-32	RP-060337	693	-	Number of HARQ processes in HS-SCCH performance tests	F	7.0.0	7.1.0	R5-061049
RP-32	RP-060337	694	-	Clarification of HS-SCCH performance requirements	F	7.0.0	7.1.0	R5-061076
RP-32	RP-060337	695	-	Beta values for HSDPA RF test 5.7A	F	7.0.0	7.1.0	R5-061436
RP-32	RP-060337	696	-	Correction to 5.2A	F	7.0.0	7.1.0	R5-061437
RP-32	RP-060337	697	-	Annex F HSET data rate clarification and corrections	F	7.0.0	7.1.0	R5-061422
RP-32	RP-060337	698	-	Addition of MAC-d PDU size and HARQ process in 9.3 and 9.4 and Annex C.8.1	F	7.0.0	7.1.0	R5-061467
RP-32	RP-060337	699	-	Correction to 5.7A and 5.13.1A waveform patterns	F	7.0.0	7.1.0	R5-061471
RP-32	RP-060337	700	-	Correction to 5.13.1A minimum power setting	F	7.0.0	7.1.0	R5-061433
RP-32	RP-060332	701	-	E-HICH test	F	7.0.0	7.1.0	R5-061447
RP-32	RP-060332	702	-	E-RGCH test	F	7.0.0	7.1.0	R5-061462
RP-32	RP-060332	703	-	Test tolerances for E-HICH and E_RGCH	F	7.0.0	7.1.0	R5-061090
RP-32	RP-060332	704	-	Definition of serving cell for E-DCH RF transmitter test cases	F	7.0.0	7.1.0	R5-061463

T Meeting	Doc-1 st -Level	CR	Rev	Subject	Cat	Version - Current	Version -New	Doc-2 nd -Level
RP-32	RP-060332	705	-	Correction to 34.121-1: HSDPA and E-DCH beta configurations	F	7.0.0	7.1.0	R5-061459
RP-32	RP-060332	706	-	Addition to 34.121-1 for HSUPA: UE max output power with HS-DPCCH and E-DCH and HS-DPCCH only release 6 and later	F	7.0.0	7.1.0	R5-061461
RP-32	RP-060332	707	-	Introduction of the demodulation of E-AGCH test case	F	7.0.0	7.1.0	R5-061445
RP-32	RP-060335	708	-	CR to 34.121-1: Introduction of improvement of performance requirements of HSDPA receiver (type 3) for UE categories 7 & 8	F	7.0.0	7.1.0	R5-061472
RP-32	RP-060334	709	-	Intorduction of Band IV to 34.121-1 Chapter 4	F	7.0.0	7.1.0	R5-061072
RP-32	RP-060334	710	-	Introduction of Band IV to 34.121-1 Chapter 5	F	7.0.0	7.1.0	R5-061073
RP-32	RP-060334	711	-	Introduction of Band IV to 34.121 Chapter 6	F	7.0.0	7.1.0	R5-061465
RP-32	RP-060334	712	-	CR to 34.121-1: Changes to Annex D to introduce UMTS 1.7/2.1 GHz (Band IV)	F	7.0.0	7.1.0	R5-061452
RP-32	RP-060334	713	-	CR to 34.121-1: Changes to chapter 8 to introduce UMTS 1.7/2.1 GHz (Band IV)	F	7.0.0	7.1.0	R5-061466
RP-32	RP-060322	714	-	Correction of UE Transmit timing 8.5.1	F	7.0.0	7.1.0	R5-061475r3
RP-33	RP-060549	715	-	Correction to the formula of CPICH_RSCH of Table 5.5.2.3	F	7.1.0	7.2.0	R5-062423
RP-33	RP-060553	716	-	Correction to 5.13.3 UE phase discontinuity	F	7.1.0	7.2.0	R5-062220
RP-33	RP-060553	717	-	Correction to 5.13.4 PRACH preamble quality	F	7.1.0	7.2.0	R5-062406
RP-33	RP-060549	718	-	Split of 34.121-1 test case 6.4 to 6.4 and 6.4A	F	7.1.0	7.2.0	R5-062407
RP-33	RP-060553	719	-	BLER test limit for TC 7.8.4 Power control in DL, different transport formats	F	7.1.0	7.2.0	R5-062129
RP-33	RP-060552	720	-	Correction to test case 7.11 Demodulation of Paging Channel (PCH)	F	7.1.0	7.2.0	R5-062450
RP-33	RP-060549	721	-	Correction to 7.8.2 Power control in the downlink, initial convergence	F	7.1.0	7.2.0	R5-062409
RP-33	RP-060549	722	-	Clarification to UL data rate in test 7.8.2 subtest 3 & 4	F	7.1.0	7.2.0	R5-062400
RP-33	RP-060549	723	-	Correction to the RRM Test cases 8.6.1.1 and 8.6.1.1A	F	7.1.0	7.2.0	R5-062411
RP-33	RP-060549	724	-	Correction to ARFCN of GSM target cell in test case 8.2.3.3	F	7.1.0	7.2.0	R5-062203
RP-33	RP-060549	725	-	Clarification to GSM target cell in test case 8.3.5.3	F	7.1.0	7.2.0	R5-062204
RP-33	RP-060549	726	-	Correction to 8.5.1 UE Transmit Timing	F	7.1.0	7.2.0	R5-062222
RP-33	RP-060560	727	-	Correction to 8.6.5.1 Correct reporting of neighbours in AWGN propagation condition	F	7.1.0	7.2.0	R5-062413
RP-33	RP-060549	728	-	Correction to Annex C.6.2 Channel combinations for BLER measurements	F	7.1.0	7.2.0	R5-062426
RP-33	RP-060567	729	-	Beta values for HSDPA RF tests	F	7.1.0	7.2.0	R5-062060
RP-33	RP-060567	730	-	Correction to beta values to be used in test 5.13.1A	F	7.1.0	7.2.0	R5-062420
RP-33	RP-060567	731	-	Correction of reference to connection diagram in 9.3.1	F	7.1.0	7.2.0	R5-062421
RP-33	RP-060567	732	-	MAC header transmission on HS-DSCH	F	7.1.0	7.2.0	R5-062439
RP-33	RP-060567	733	-	New Rel-6 RRM test case: 8.3.8 Serving HS-DSCH cell change	F	7.1.0	7.2.0	R5-062422
RP-33	RP-060567	734	-	Changes to annex of 34.121-1 for the testcase "Serving HS-DSCH cell change"	F	7.1.0	7.2.0	R5-062231
RP-33	RP-060567	735	-	Correction of beta factors during the measurement period for test cases in 5.xA tests	F	7.1.0	7.2.0	R5-062441
RP-33	RP-060562	736	-	New HSUPA Test Case to 34.121-1: E-TFC restriction in UE	F	7.1.0	7.2.0	R5-062452
RP-33	RP-060562	737	-	New HSUPA Test Case to 34.121-1: Detection Inter-Cell Handover conditions for E-HICH for RLS not containing the Serving E-DCH cell and containing the Serving E-DCH cell	F	7.1.0	7.2.0	R5-062448
RP-33	RP-060562	738	-	New HSUPA Test Case to 34.121-1: Detection Inter-Cell Handover conditions for E-RGCH	F	7.1.0	7.2.0	R5-062449
RP-33	RP-060562	739	-	Clarification on the loopback test mode for E-DCH RF test cases	F	7.1.0	7.2.0	R5-062433
RP-33	RP-060562	740	-	Introduction of E-AGCH information sequence for E-AGCH test case.	F	7.1.0	7.2.0	R5-062434
RP-33	RP-060562	741	-	Test tolerance for E-AGCH test case.	F	7.1.0	7.2.0	R5-062211
RP-33	RP-060549	742	-	Correction to 5.11 and 6.5.2.2	F	7.1.0	7.2.0	R5-062436
RP-33	RP-060560	743	-	Addition of phase discontinuity to HSDPA EVM test	F	7.1.0	7.2.0	R5-062444r2
RP-33	RP-060562	744	-	Beta values for E-DCH RF tests	F	7.1.0	7.2.0	R5-062447r2
RP-34	RP-060731	745	-	Correction to call setup procedure	F	7.2.0	7.3.0	R5-063403
RP-34	RP-060731	746	-	Correction to PHYSICAL CHANNEL RECONFIGURATION messages	F	7.2.0	7.3.0	R5-063404
RP-34	RP-060735	747	-	Corrections to Annex C table references	F	7.2.0	7.3.0	R5-063405

T Meeting	Doc-1 st -Level	CR	Rev	Subject	Cat	Version - Current	Version -New	Doc-2 nd -Level
RP-34	RP-060735	748	-	Clarification to HSDPA EVM and phase discontinuity timing diagrams	F	7.2.0	7.3.0	R5-063406
RP-34	RP-060735	749	-	Clarification on the MAC headers for HSDPA test cases	F	7.2.0	7.3.0	R5-063230
RP-34	RP-060731	750	-	Correction to transmit diversity test cases	F	7.2.0	7.3.0	R5-063447
RP-34	RP-060731	751	-	Correction to SHO test cases	F	7.2.0	7.3.0	R5-063408
RP-34	RP-060731	752	-	Correction to TC 7.8.2	F	7.2.0	7.3.0	R5-063453
RP-34	RP-060739	753	-	Correction to RRM Test Case to 34.121-1: Band VI Inter-Frequency Band test cases interference issue.	F	7.2.0	7.3.0	R5-063461
RP-34	RP-060731	754	-	Correction to the RRM Test case 8.3.5.3	F	7.2.0	7.3.0	R5-063410
RP-34	RP-060731	755	-	Correction to RRM Test case 8.6.1.2A	F	7.2.0	7.3.0	R5-063411
RP-34	RP-060731	756	-	Correction to 8.3.4	F	7.2.0	7.3.0	R5-063412
RP-34	RP-060731	757	-	Correction to 8.3.5	F	7.2.0	7.3.0	R5-063413
RP-34	RP-060731	758	-	Correction to 8.4.1	F	7.2.0	7.3.0	R5-063414
RP-34	RP-060731	759	-	Correction to MEASUREMENT CONTROL messages in 8.7.2.1.1 and 8.7.6.1	F	7.2.0	7.3.0	R5-063415
RP-34	RP-060731	760	-	Update of Annex I	F	7.2.0	7.3.0	R5-063416
RP-34	RP-060731	761	-	Correction to MEASUREMENT CONTROL messages in RRM	F	7.2.0	7.3.0	R5-063417
RP-34	RP-060732	762	-	Correction to UARFCN frequency offset for Band VII	F	7.2.0	7.3.0	R5-063070
RP-34	RP-060735	763	-	Corrections to CQI tests	F	7.2.0	7.3.0	R5-063418
RP-34	RP-060739	764	-	Correction of reference to connection diagram in 9.3.3 and 9.3.5	F	7.2.0	7.3.0	R5-063419
RP-34	RP-060735	765	-	Correction to Downlink Physical Channels for HSDPA Closed Loop Transmit Diversity	F	7.2.0	7.3.0	R5-063422
RP-34	RP-060735	766	-	Correction to Annex F.6.1.8 and F.6.3.4	F	7.2.0	7.3.0	R5-063420
RP-34	RP-060739	767	-	New test case - UE Relative code domain power accuracy	F	7.2.0	7.3.0	R5-063452
RP-34	RP-060743	768	-	Correction to TC 10.2.1 E-HICH test, single link	F	7.2.0	7.3.0	R5-063456
RP-34	RP-060743	769	-	Correction to TC 10.3.1 E-RGCH , single link	F	7.2.0	7.3.0	R5-063457
RP-34	RP-060743	770	-	Correction to HSUPA Test Case to 34.121-1: Detection Inter-Cell Handover conditions for E-HICH for RLS not containing the Serving E-DCH cell and containing the Serving E-DCH cell	F	7.2.0	7.3.0	R5-063468
RP-34	RP-060743	771	-	Correction of test case: Detection in Inter-Cell Handover conditions for E-RGCH.	F	7.2.0	7.3.0	R5-063464
RP-34	RP-060743	772	-	Correction to HSUPA Test Case to 34.121-1: E-TFC restriction in UE 10ms TTI test case and addition of 2ms TTI test case	F	7.2.0	7.3.0	R5-063465
RP-34	RP-060743	773	-	Additions to HSUPA Test Case to 34.121-1: Test Tolerances for E-TFC restriction in UE 10ms TTI test case and 2ms TTI test case	F	7.2.0	7.3.0	R5-063438
RP-34	RP-060743	774	-	Adding the notice to Sub-test 3 in E-DCH Test cases	F	7.2.0	7.3.0	R5-063439
RP-34	RP-060743	775	-	Adding downlink channel and power definition for E-DCH tests	F	7.2.0	7.3.0	R5-063469
RP-34	RP-060743	776	-	Clarification on the MAC headers for E-DCH test cases	F	7.2.0	7.3.0	R5-063232
RP-34	RP-060743	777	-	Clarification on the beta values for the E-AGCH test	F	7.2.0	7.3.0	R5-063466
RP-34	RP-060743	778	-	UE Transmission Power Headroom test	F	7.2.0	7.3.0	R5-063470
RP-34	RP-060743	779	-	Addition of statistical testing of RRM delay performance for test case 8.4.4 for 10 ms TTI E-DCH E-TFC restriction and 2 ms TTI E-DCH E-TFC restriction	F	7.2.0	7.3.0	R5-063449
RP-34	RP-060735	780	-	Corrections to test case 5.7A HS-DPCCH power time template	F	7.2.0	7.3.0	R5-063462r1
RP-34	RP-060743	781	-	Correction to set UE to maximum output power	F	7.2.0	7.3.0	R5-063434r1
RP-35	RP-070101	782	-	Correction to 34.121-1 test case for: Change of TFC	F	7.3.0	7.4.0	R5-070501
RP-35	RP-070105	783	-	Correction to 34.121-1 test case for: Change to peak code domain error applicability	F	7.3.0	7.4.0	R5-070173
RP-35	RP-070101	784	-	Correction to test tolerances in test cases 7.7.1 and 7.7.2.	F	7.3.0	7.4.0	R5-070216
RP-35	RP-070101	785	-	Correction to test requirements in section 8.4.2.4 and F.4.4	F	7.3.0	7.4.0	R5-070502
RP-35	RP-070101	786	-	Correction to Table 8.3.7.2.1 and Table F.4.1	F	7.3.0	7.4.0	R5-070555
RP-35	RP-070101	787	-	Correction to the content of Measurement Control message in RRM Test cases 8.3.2.2, 8.6.2.1 and 8.6.2.2	F	7.3.0	7.4.0	R5-070503
RP-35	RP-070101	788	-	Correction of the definition of known cell	F	7.3.0	7.4.0	R5-070218
RP-35	RP-070101	789	-	Correction to system uncertainty of GSM test cases	F	7.3.0	7.4.0	R5-070256
RP-35	RP-070111	790	-	Correction to SIB11for 8.6.5.1 in AnnexI	F	7.3.0	7.4.0	R5-070257
RP-35	RP-070111	791	-	Correction to 8.3.8	F	7.3.0	7.4.0	R5-070504
RP-35	RP-070101	792	-	Default Qrxlevmin value for RRM Testcases	F	7.3.0	7.4.0	R5-070505

T Meeting	Doc-1 st -Level	CR	Rev	Subject	Cat	Version - Current	Version -New	Doc-2 nd -Level
RP-35	RP-070101	793	-	Correction to Active Set Update message in Annex I	F	7.3.0	7.4.0	R5-070506
RP-35	RP-070105	794	-	Correction to reference TFC in Annex I	F	7.3.0	7.4.0	R5-070219
RP-35	RP-070105	795	-	Continuous DPCH transmission during HSDPA and E-DCH performance tests	F	7.3.0	7.4.0	R5-070220
RP-35	RP-070105	796	-	Removal of the fixed MAC-hs header option for HSDPA test cases	F	7.3.0	7.4.0	R5-070290
RP-35	RP-070105	797	-	Correction to HSDPA Performance test cases	F	7.3.0	7.4.0	R5-070583
RP-35	RP-070105	798	-	Clarification of CQI test cases	F	7.3.0	7.4.0	R5-070584
RP-35	RP-070111	799	-	Introduction of Relative Code Domain Error	F	7.3.0	7.4.0	R5-070557
RP-35	RP-070096	800	-	E-TFC selection for E-DCH maximum power tests	F	7.3.0	7.4.0	R5-070512
RP-35	RP-070096	801	-	Corrections to method of test and limits for E-DCH RRM test 8.4.4.1	F	7.3.0	7.4.0	R5-070582
RP-35	RP-070096	802	-	Correction to HSUPA Test Case to 34.121-1: E-TFC restriction in UE 10ms TTI test case and 2ms TTI test case	F	7.3.0	7.4.0	R5-070576
RP-35	RP-070096	803	-	Reduction of lower limits in TC 5.2B	F	7.3.0	7.4.0	R5-070223
RP-35	RP-070096	804	-	Addition of test system uncertainties and test tolerances for inter cell E-DCH tests	F	7.3.0	7.4.0	R5-070524
RP-35	RP-070096	805	-	Correction to E-AGCH test case	F	7.3.0	7.4.0	R5-070520
RP-35	RP-070096	806	-	Removal of the 2ms test from 10.2.1(E-HICH, Single link performance)	F	7.3.0	7.4.0	R5-070562
RP-35	RP-070096	807	-	Separation of the 2ms test from 10.2.1(E-HICH, Single link performance)	F	7.3.0	7.4.0	R5-070563
RP-35	RP-070096	808	-	Removal of the 2ms test from 10.2.2.1(E-HICH, SHO, RLS not cont....)	F	7.3.0	7.4.0	R5-070577
RP-35	RP-070096	809	-	Separation of the 2ms test from 10.2.2.1(E-HICH, SHO, RLS not cont...)	F	7.3.0	7.4.0	R5-070578
RP-35	RP-070096	810	-	Removal of the 2ms test from 10.2.2.2(E-HICH, SHO, RLS containing....)	F	7.3.0	7.4.0	R5-070579
RP-35	RP-070096	811	-	Separation of the 2ms test from 10.2.2.2(E-HICH, SHO, RLS containing....)	F	7.3.0	7.4.0	R5-070567
RP-35	RP-070096	812	-	Removal of the 2ms test from 10.3.1(E-RGCH, Single link performance)	F	7.3.0	7.4.0	R5-070568
RP-35	RP-070096	813	-	Separation of the 2ms test from 10.3.1(E-RGCH, single link)	F	7.3.0	7.4.0	R5-070569
RP-35	RP-070097	814	-	Correction to 10.3.2(E-RGCH, SHO)	F	7.3.0	7.4.0	R5-070570
RP-35	RP-070097	815	-	Statistical annex for E-DCH performance tests	F	7.3.0	7.4.0	R5-070561
RP-35	RP-070097	816	-	Statistical requirements for test cases 8.4.4	F	7.3.0	7.4.0	R5-070515
RP-35	RP-070090	817	-	New test case: Demodulation of MTCH and cell identification – RLC SDU Error Rate	F	7.3.0	7.4.0	R5-070580
RP-35	RP-070090	818	-	Addition of reference measurement channel, downlink physical channels configuration and VA3 fading condition for MBMS RF testing	F	7.3.0	7.4.0	R5-070546
RP-35	RP-070090	819	-	Introduction of the new demodulation of MTCH test case	F	7.3.0	7.4.0	R5-070547
RP-35	RP-070094	820	-	CR to 34.121-1: Introduction of FDD Mode Test frequencies for Operating Band X (Extended 1.7/2.1 GHz) to Chapter 4	F	7.3.0	7.4.0	R5-070162
RP-35	RP-070094	821	-	CR to 34.121-1: Introduction of FDD Band X (Extended UMTS 1.7/2.1 GHz) to Chapter 5	F	7.3.0	7.4.0	R5-070536
RP-35	RP-070094	822	-	CR to 34.121-1: Introduction of FDD Band X (Extended UMTS 1.7/2.1 GHz) to Chapter 6	F	7.3.0	7.4.0	R5-070537
RP-35	RP-070094	823	-	CR to 34.121-1: Introduction of FDD Band X (Extended UMTS 1.7/2.1 GHz) to Annex D	F	7.3.0	7.4.0	R5-070165
RP-35	RP-070094	824	-	CR to 34.121-1: Introduction of FDD Band X (Extended UMTS 1.7/2.1 GHz) to Annex F	F	7.3.0	7.4.0	R5-070166
RP-35	RP-070101	825	-	Test time reduction to event trigger tests	F	7.3.0	7.4.0	R5-070560
RP-35	RP-070090	826	-	New test case: Cell re-selection during an MBMS session, one UTRAN inter-frequency and 2 GSM cells present in the neighbour list	F	7.3.0	7.4.0	R5-070573
RP-36	RP-070357	827	-	Uncertainties for E-TFC restriction test cases 8.4.4.1 and 8.4.4.2.	F	7.4.0	7.5.0	R5-071064
RP-36	RP-070368	828	-	CR to 34.121-1: Introduction of FDD Band X (Extended UMTS 1.7/2.1 GHz) to Chapter 8	F	7.4.0	7.5.0	R5-071080
RP-36	RP-070368	829	-	CR to 34.121-1: Introduction of FDD Band X (Extended UMTS 1.7/2.1 GHz) to Annex F for RRM test cases	F	7.4.0	7.5.0	R5-071081
RP-36	RP-070344	830	-	TC 8.3.4 - addition of physical channel reconfiguration message	F	7.4.0	7.5.0	R5-071103
RP-36	RP-070356	831	-	Correction to connection diagram to use for test 9.2.1G	F	7.4.0	7.5.0	R5-071151

T Meeting	Doc-1 st -Level	CR	Rev	Subject	Cat	Version - Current	Version -New	Doc-2 nd -Level
RP-36	RP-070354	832	-	Addition of settings for the serving cell in test case 5.2AA	F	7.4.0	7.5.0	R5-071153
RP-36	RP-070349	833	-	Adding the AICH power level to TC 7.11	F	7.4.0	7.5.0	R5-071179
RP-36	RP-070350	834	-	TC 7.8.4 and RRC CONNECTION SETUP message in Annex I	F	7.4.0	7.5.0	R5-071180
RP-36	RP-070357	835	-	Corrections to test procedure of test case 5.2B	F	7.4.0	7.5.0	R5-071182
RP-36	RP-070357	836	-	Removing tables C.11.1.1 and C.11.1.2 from Annex C	F	7.4.0	7.5.0	R5-071183
RP-36	RP-070350	837	-	Clarification to DL DTCH for HSDPA test cases and E-DCH test cases in section 5.	F	7.4.0	7.5.0	R5-071203
RP-36	RP-070363	838	-	Connection diagram for three cells tests with multipath fading propagation is missing	F	7.4.0	7.5.0	R5-071207
RP-36	RP-070344	839	-	Correction to Measurement report message in Annex I for Inter RAT tests	F	7.4.0	7.5.0	R5-071217
RP-36	RP-070357	840	-	Correction to RB setup in 5.2B	F	7.4.0	7.5.0	R5-071222
RP-36	RP-070357	841	-	Correction to missed down procedure in 10.3.2	F	7.4.0	7.5.0	R5-071226
RP-36	RP-070357	842	-	Correction of procedure for 10.3.1.1	F	7.4.0	7.5.0	R5-071228
RP-36	RP-070363	843	-	Correction to the demodulation of MTCH test case	F	7.4.0	7.5.0	R5-071255
RP-36	RP-070344	844	-	Applicability change of vibration condition to 34.121-1 test case 5.3	F	7.4.0	7.5.0	R5-071323
RP-36	RP-070344	845	-	Correction to 5.13.1	F	7.4.0	7.5.0	R5-071324
RP-36	RP-070350	846	-	Correction of test parameter 'Available signature Start Index and Available signature End Index' for TC 5.13.4 in TS 34.121-1	F	7.4.0	7.5.0	R5-071325
RP-36	RP-070350	847	-	Correction to 6.3A	F	7.4.0	7.5.0	R5-071326
RP-36	RP-070349	848	-	Correction to 7.11	F	7.4.0	7.5.0	R5-071327
RP-36	RP-070350	849	-	Correction to 7.8.4	F	7.4.0	7.5.0	R5-071328
RP-36	RP-070354	850	-	UTRA Carrier RSSI relative accuracy	F	7.4.0	7.5.0	R5-071330
RP-36	RP-070363	851	-	Tc 8.3.6.3 - modification of table 8.3.6.3.1 and addition of SIB11	F	7.4.0	7.5.0	R5-071332
RP-36	RP-070354	852	-	Correction to 8.3.8	F	7.4.0	7.5.0	R5-071334
RP-36	RP-070344	853	-	Correction to Annex K - ' cell configuration mapping' table	F	7.4.0	7.5.0	R5-071336
RP-36	RP-070350	854	-	Correction to 34.121-1 test case for: UE Transmitted Power test tolerances to Annex F	F	7.4.0	7.5.0	R5-071339
RP-36	RP-070354	855	-	Applicability of DL power tables	F	7.4.0	7.5.0	R5-071340
RP-36	RP-070350	856	-	Clarification to fading conditions for Enhanced Performance Requirements Type 3 and Transmit Diversity	F	7.4.0	7.5.0	R5-071341
RP-36	RP-070350	857	-	MAC-d PDU size for UE Categories 7 and above in 9.3	F	7.4.0	7.5.0	R5-071342
RP-36	RP-070354	858	-	Correction to performance TCs for HS-SCCH detection	F	7.4.0	7.5.0	R5-071343
RP-36	RP-070350	859	-	CR to 34.121-1:Introduction of test cases for multi-path fading intra-frequency cell identification	F	7.4.0	7.5.0	R5-071345
RP-36	RP-070350	860	-	CR to 34.121-1:Introduction of test tolerances for multi-path fading intra-frequency cell identification RRM test cases	F	7.4.0	7.5.0	R5-071346
RP-36	RP-070350	861	-	CR to 34.121-1:Introduction of default message contents for multi-path fading intra-frequency cell identification RRM test cases	F	7.4.0	7.5.0	R5-071347
RP-36	RP-070357	862	-	Corrections to E-TFCI restriction test cases 8.4.4.1 and 8.4.4.2	F	7.4.0	7.5.0	R5-071349
RP-36	RP-070357	863	-	Correction to E-DCH Power Setting	F	7.4.0	7.5.0	R5-071355
RP-36	RP-070357	864	-	Corrections to HSUPA test case 8.4.4.1	F	7.4.0	7.5.0	R5-071356
RP-36	RP-070363	865	-	Correction to Annex E.5B	F	7.4.0	7.5.0	R5-071357
RP-36	RP-070350	866	-	Correction of parameter for TC 5.13.4 in TS 34.121-1	F	7.4.0	7.5.0	R5-071362
RP-36	RP-070350	867	-	Correction to 34.121-1 test case for: UE transmitted power	F	7.4.0	7.5.0	R5-071363
RP-36	RP-070344	868	-	TC 8.6.4.1 test 1 and 2 - addition of physical channel reconfiguration messages	F	7.4.0	7.5.0	R5-071364
RP-36	RP-070354	869	-	Corrections to TC 8.6.5.1Correct reporting of neighbours...	F	7.4.0	7.5.0	R5-071366
RP-36	RP-070363	870	-	Typo correction on Tc 8.3.6.3.	F	7.4.0	7.5.0	R5-071367
RP-36	RP-070357	871	-	Introduction of Relative Code Domain Power Accuracy for HS-DPCCH and E-DCH	F	7.4.0	7.5.0	R5-071369
RP-36	RP-070357	872	-	Introduction of Relative Code Domain Error with HS-DPCCH and E-DCH	F	7.4.0	7.5.0	R5-071370
RP-36	RP-070357	873	-	RLC SDU size for E-DCH test cases in Annex C	F	7.4.0	7.5.0	R5-071371
RP-36	RP-070357	874	-	Statistical requirements for 8.7.9 UE Transmission Power Headroom	F	7.4.0	7.5.0	R5-071372

T Meeting	Doc-1 st -Level	CR	Rev	Subject	Cat	Version - Current	Version -New	Doc-2 nd -Level
RP-36	RP-070363	875	-	Statistical Requirements for TC 8.3.6.3	F	7.4.0	7.5.0	R5-071373
RP-36	RP-070363	876	-	MBMS New test case: Cell Reselection during an MBMS session, one frequency present in neighbour list	F	7.4.0	7.5.0	R5-071374
RP-36	RP-070357	877	-	Correction to E-TFC restriction in UE	F	7.4.0	7.5.0	R5-071375
RP-36	RP-070357	878	-	RLC SDU size for E-DCH test cases	F	7.4.0	7.5.0	R5-071376
RP-36	RP-070357	879	-	Corrections to HSUPA test case 8.4.4.2	F	7.4.0	7.5.0	R5-071377
RP-36	RP-070344	880	-	Correction of testcase 8.3.4 for Inter-system Handover from UTRAN FDD to GSM	F	7.4.0	7.5.0	R5-071249
RP-36	RP-070344	881	-	Corrections to RRM test case 8.7.3.A when run in FDD Band V and VI	F	7.4.0	7.5.0	R5-071379r1
RP-37	RP-070588	882	-	Correction to call setup procedure	F	7.5.0	7.6.0	R5-072256
RP-37	RP-070588	883	-	Correction to ACTIVESET UPDATE message in Annex I	F	7.5.0	7.6.0	R5-072257
RP-37	RP-070596	884	-	CR to 34.121-1: New Requirements for Fast L1 Synchronization	F	7.5.0	7.6.0	R5-072134
RP-37	RP-070593	885	-	Correction to cell configurations of 8.7.3.2 and 8.7.3D in Annex K	F	7.5.0	7.6.0	R5-072258
RP-37	RP-070588	886	-	Clarification of Transmission gap pattern sequence	F	7.5.0	7.6.0	R5-072260
RP-37	RP-070596	887	-	Correction to Annex I	F	7.5.0	7.6.0	R5-072262
RP-37	RP-070588	888	-	Removing test procedure for event trigger tests	F	7.5.0	7.6.0	R5-072263
RP-37	RP-070596	889	-	Correction to MEASUREMENT CONTROL message (Intra Frequency) in 8.6.5.1	F	7.5.0	7.6.0	R5-072575
RP-37	RP-070596	890	-	CR to 34.121-1: New FDD UE receiver performance requirements for Release 6 test tolerances to Annex F	F	7.5.0	7.6.0	R5-072129
RP-37	RP-070596	891	-	CR to 34.121-1: Introduction of new compressed mode reference pattern in Annex C	F	7.5.0	7.6.0	R5-072130
RP-37	RP-070596	892	-	CR to 34.121-1: Introduction of test case for correct reporting of neighbours in fading propagation condition using TGL1=14 RRM test tolerances	F	7.5.0	7.6.0	R5-072132
RP-37	RP-070596	893	-	Correction to channel power of T0 in 8.3.8	F	7.5.0	7.6.0	R5-072265
RP-37	RP-070596	894	-	CR to 34.121-1: Correction to the Inter Frequency Cell Identification test cases test tolerances	F	7.5.0	7.6.0	R5-072406
RP-37	RP-070601	895	-	Scheduling info Power offset for E-DCH E-TFC restriction TCs	F	7.5.0	7.6.0	R5-072055
RP-37	RP-070601	896	-	Correction of the maximum channelisation codes allowed in test cases 8.4.4.1 and 8.4.4.2.	F	7.5.0	7.6.0	R5-072056
RP-37	RP-070601	897	-	Correction to reference for E-DCH Test Case	F	7.5.0	7.6.0	R5-072060
RP-37	RP-070601	898	-	Correction to E-DCH 2 cell TCs	F	7.5.0	7.6.0	R5-072071
RP-37	RP-070601	899	-	Correction to E-DCH Active set update message	F	7.5.0	7.6.0	R5-072072
RP-37	RP-070601	900	-	Corrections to Table C.11.3.1 in Annex C	F	7.5.0	7.6.0	R5-072243
RP-37	RP-070601	901	-	Correction to HS-PDSCH power in section 10 test cases	F	7.5.0	7.6.0	R5-072269
RP-37	RP-070608	902	-	Addition of test tolerances for MBMS RF and RRM test cases	F	7.5.0	7.6.0	R5-072342
RP-37	RP-070615	903	-	Introduction of continuous packet connectivity (CPC) to "Out-of-synchronization handling of output power"	F	7.5.0	7.6.0	R5-072179
RP-37	RP-070596	907	-	Add test tolerance and test frequencies for 5.13.2A and 5.13.2B UE Relative Code Domain Error.	F	7.5.0	7.6.0	R5-072353
RP-37	RP-070596	908	-	Replace tentative test tolerances for UE Relative Code Domain Power Accuracy tests 5.2C and 5.2D.	F	7.5.0	7.6.0	R5-072354
RP-37	RP-070596	909	-	Add frequency range 4 to 6.5 Blocking Characteristics	F	7.5.0	7.6.0	R5-072355
RP-37	RP-070596	910	-	CR to 34.121-1: New FDD UE receiver performance requirements for Release 6	F	7.5.0	7.6.0	R5-072356
RP-37	RP-070588	911	-	CR to 34.121-1: Correction to FDD/FDD Soft Handover test cases	F	7.5.0	7.6.0	R5-072357
RP-37	RP-070596	912	-	CR to 34.121-1: Introduction of test case for correct reporting of neighbours in fading propagation condition using TGL1=14 RRM test case	F	7.5.0	7.6.0	R5-072358
RP-37	RP-070593	913	-	Correction to measurement control message in 8.7.3D	F	7.5.0	7.6.0	R5-072363
RP-37	RP-070596	914	-	Correction to frequency separation in 8.7.3.2	F	7.5.0	7.6.0	R5-072364
RP-37	RP-070593	915	-	Correction to HSDPA diversity performance TCs	F	7.5.0	7.6.0	R5-072366
RP-37	RP-070601	916	-	Corrections to E-DCH UE Power Headroom TC	F	7.5.0	7.6.0	R5-072370
RP-37	RP-070601	917	-	Definition of uncertainties for E-DCH UE Power Headroom TC	F	7.5.0	7.6.0	R5-072371
RP-37	RP-070601	918	-	Corrections to E-DCH E-TFC restriction Test Cases	F	7.5.0	7.6.0	R5-072372
RP-37	RP-070601	919	-	Correction to 5.2D UE Relative Code Domain Power Accuracy for HS-DPCCH and E-DCH	F	7.5.0	7.6.0	R5-072375
RP-37	RP-070601	920	-	Corrections to Section 10	F	7.5.0	7.6.0	R5-072377

T Meeting	Doc-1 st -Level	CR	Rev	Subject	Cat	Version - Current	Version -New	Doc-2 nd -Level
RP-37	RP-070608	921	-	Downlink physical channels code allocation for MBMS test cases	F	7.5.0	7.6.0	R5-072381
RP-37	RP-070615	922	-	Introduction of continuous packet connectivity (CPC) to E-TFC restriction	F	7.5.0	7.6.0	R5-072384
RP-37	RP-070618	923	-	New E-DCH TC: RLS not containing the Serving E-DCH cell (10ms TTI, Type 1)	F	7.5.0	7.6.0	R5-072388
RP-37	RP-070618	924	-	New E-DCH TC: RLS not containing the Serving E-DCH cell (2ms TTI, Type 1)	F	7.5.0	7.6.0	R5-072389
RP-37	RP-070618	925	-	New E-DCH TC: RLS containing the Serving E-DCH cell (10ms TTI, Type 1)	F	7.5.0	7.6.0	R5-072390
RP-37	RP-070618	926	-	New E-DCH TC: RLS containing the Serving E-DCH cell (2ms TTI, Type 1)	F	7.5.0	7.6.0	R5-072391
RP-37	RP-070618	927	-	New E-DCH TC: E-RGCH single link performance (10ms TTI, Type 1)	F	7.5.0	7.6.0	R5-072392
RP-37	RP-070618	928	-	New E-DCH TC: E-RGCH single link performance (2ms TTI, Type 1)	F	7.5.0	7.6.0	R5-072393
RP-37	RP-070618	929	-	New E-DCH TC: Detection in Inter-Cell Handover conditions (Type 1)	F	7.5.0	7.6.0	R5-072394
RP-37	RP-070618	930	-	New E-DCH TC: E-AGCH single link performance (Type 1)	F	7.5.0	7.6.0	R5-072395
RP-37	RP-070618	931	-	Measurement uncertainties for E-DCH RX diversity (Type 1) tests	F	7.5.0	7.6.0	R5-072396
RP-37	RP-070618	932	-	Downlink physical Channels for E-DCH RX-diversity (Type 1) tests	F	7.5.0	7.6.0	R5-072397
RP-37	RP-070618	933	-	New E-DCH Connection Diagram: 2 cells/Fading/RX-diversity	F	7.5.0	7.6.0	R5-072343
RP-37	RP-070617	934	-	New test case for demodulation of MTCH and enhanced performance requirement 1	F	7.5.0	7.6.0	R5-072385
RP-37	RP-070600	935	-	UE performance requirements for high speed train	F	7.5.0	7.6.0	R5-072413
RP-37	RP-070596	936	-	CR to 34.121-1: Correction to the Inter Frequency Cell Identification test cases	F	7.5.0	7.6.0	R5-072405
RP-37	RP-070592	937	-	Correction to 8.6.1.2A – invalid IE for event 1C	F	7.5.0	7.6.0	R5-072410
RP-37	RP-070596	938	-	CR to 34.121-1: Correction for testing receiver diversity UEs	F	7.5.0	7.6.0	R5-072402
RP-37	RP-070601	939	-	Correction to E-DCH AG detection TC	F	7.5.0	7.6.0	R5-072403
RP-37	RP-070601	940	-	Correction to 10.4 (E-AGCH)	F	7.5.0	7.6.0	R5-072400
RP-37	RP-070618	941	-	New E-DCH TC: E-HICH single link performance (10ms TTI, Type 1)	F	7.5.0	7.6.0	R5-072414
RP-37	RP-070618	942	-	New E-DCH TC: E-HICH single link performance (2ms TTI, Type 1)	F	7.5.0	7.6.0	R5-072415
RP-37	RP-070601	943	-	Corrections to section 5.2B maximum output power with HS-DPCCH and E-DCH procedure	F	7.5.0	7.6.0	R5-072417
RP-37	RP-070601	944	-	Correction to signalling pattern on the E-RGCH in 10.3.1 and 10.3.2	F	7.5.0	7.6.0	R5-072418
RP-37	RP-070600	945	-	Production of 34.121-1 Rel-7 pointer version to point to Rel-8 of the spec	F	7.5.0	7.6.0	R5-072591
RP-37	RP-070599	904	-	Introduction of UMTS1500(Band XI) requirements to Chapter 4, 5 and 6	F	7.5.0	8.0.0	R5-072274
RP-37	RP-070599	905	-	Introduction of UMTS1500(Band XI) requirements to Chapter 8	F	7.5.0	8.0.0	R5-072275
RP-37	RP-070599	906	-	Introduction of UMTS1500(Band XI) requirements to Annex D and F	F	7.5.0	8.0.0	R5-072276

History

Document history		
V8.0.0	October 2007	Publication