

ETSI TS 134 229-3 V9.9.0 (2013-10)



**Universal Mobile Telecommunications System (UMTS);
LTE;
Internet Protocol (IP)
multimedia call control protocol based on
Session Initiation Protocol (SIP)
and Session Description Protocol (SDP);
User Equipment (UE) conformance specification;
Part 3: Abstract test suite (ATS)
(3GPP TS 34.229-3 version 9.9.0 Release 9)**



Reference

RTS/TSGR-0534229-3v990

Keywords

LTE,UMTS

ETSI

650 Route des Lucioles
F-06921 Sophia Antipolis Cedex - FRANCE

Tel.: +33 4 92 94 42 00 Fax: +33 4 93 65 47 16

Siret N° 348 623 562 00017 - NAF 742 C
Association à but non lucratif enregistrée à la
Sous-Préfecture de Grasse (06) N° 7803/88

Important notice

Individual copies of the present document can be downloaded from:

<http://www.etsi.org>

The present document may be made available in more than one electronic version or in print. In any case of existing or perceived difference in contents between such versions, the reference version is the Portable Document Format (PDF). In case of dispute, the reference shall be the printing on ETSI printers of the PDF version kept on a specific network drive within ETSI Secretariat.

Users of the present document should be aware that the document may be subject to revision or change of status. Information on the current status of this and other ETSI documents is available at

<http://portal.etsi.org/tb/status/status.asp>

If you find errors in the present document, please send your comment to one of the following services:

http://portal.etsi.org/chaicor/ETSI_support.asp

Copyright Notification

No part may be reproduced except as authorized by written permission.
The copyright and the foregoing restriction extend to reproduction in all media.

© European Telecommunications Standards Institute 2013.
All rights reserved.

DECT™, PLUGTESTS™, UMTS™ and the ETSI logo are Trade Marks of ETSI registered for the benefit of its Members.
3GPP™ and LTE™ are Trade Marks of ETSI registered for the benefit of its Members and
of the 3GPP Organizational Partners.
GSM® and the GSM logo are Trade Marks registered and owned by the GSM Association.

Intellectual Property Rights

IPRs essential or potentially essential to the present document may have been declared to ETSI. The information pertaining to these essential IPRs, if any, is publicly available for **ETSI members and non-members**, and can be found in ETSI SR 000 314: "*Intellectual Property Rights (IPRs); Essential, or potentially Essential, IPRs notified to ETSI in respect of ETSI standards*", which is available from the ETSI Secretariat. Latest updates are available on the ETSI Web server (<http://ipr.etsi.org>).

Pursuant to the ETSI IPR Policy, no investigation, including IPR searches, has been carried out by ETSI. No guarantee can be given as to the existence of other IPRs not referenced in ETSI SR 000 314 (or the updates on the ETSI Web server) which are, or may be, or may become, essential to the present document.

Foreword

This Technical Specification (TS) has been produced by ETSI 3rd Generation Partnership Project (3GPP).

The present document may refer to technical specifications or reports using their 3GPP identities, UMTS identities or GSM identities. These should be interpreted as being references to the corresponding ETSI deliverables.

The cross reference between GSM, UMTS, 3GPP and ETSI identities can be found under <http://webapp.etsi.org/key/queryform.asp>.

Contents

Intellectual Property Rights	2
Foreword.....	2
Foreword.....	6
Introduction	6
1 Scope	7
2 References	7
3 Definitions and abbreviations.....	9
3.1 Definitions	9
3.2 Abbreviations	9
4 Requirements on the TTCN development.....	9
5 Test method and test model.....	10
5.1 Test method	10
5.2 IMS CC test model	10
5.2.1 Ports interfacing to SS	10
5.2.1.1 Data ports	10
5.2.1.2 Security Associations Setup	10
5.2.1.3 Control ports	11
5.2.2 SAD	12
5.2.3 Network interface	12
5.2.4 SigComp and related control port.....	12
5.2.5 SIP TTCN 3 Codec.....	13
5.2.6 DHCP and DNS data ports	13
5.3 Upper Tester (UT).....	13
5.4 TTCN-3.....	13
5.5 Support of XCAP	13
5.5.1	14
5.5.2 XCAP server functionality.....	14
5.6 Extension of the Test Model to support 36.523-3 Interface	16
6 ASP definitions	16
6.1 Control ASP	16
6.1.1 Cell Control	17
6.1.2 IdleUpdated.....	18
6.1.3 PDPContext	19
6.1.4 IP Configuration	21
6.1.5 SA Database.....	23
6.1.6 Emergency CS Call.....	24
6.1.7 CS Voice Call	25
6.2 IMS-CC Data ASP definitions	25
6.2.1 ASP_DataRequest.....	25
6.2.2 ASP_DataResponse	26
6.3 Ut ASP definitions.....	26
6.4 HTTP Layer ASP definitions	26
6.5 XCAP server ASP definitions	28
6.6 Positioning / ASP definitions	29
7 Codec definitions for IP User Data	29
7.1 Introduction	29
7.2 General Aspects.....	29
7.3 Requirements on abstract message syntax for IMS (SIP, SDP)	30
7.3.1 Type definition - Syntax / Semantic aspects	30
7.3.2 Deviations of the type definition semantic	30
7.3.3 Additional requirements for codec implementations (SIP/IMS Message	31

7.3.3.1	Differences between BNF - TTCN-3 Type Mapping.....	31
7.3.4	Additional requirements for codec implementations (Message Body)	34
7.3.5	Additional requirements for codec implementations (SDP Body).....	35
7.3.5.1	Differences between BNF - SDP Type Mapping	35
7.3.5.2	Defined attributes	36
7.3.6	Additional requirements for codec implementations (HTTP).....	37
7.3.7	Additional requirements for codec implementations (XML).....	37
7.4	Requirements for codec implementations (DHCP, DNS)	38
8	Design consideration	38
8.1	Bearer Configurations for IMS Testing.....	38
8.1.1	Bearer Information for UTRAN	38
8.1.2	Bearer Information for GERAN	38
8.1.3	Bearer Information for E-UTRA	38
8.2	Security	38
8.3	External Function Definitions	38
8.4	AT commands	39
Annex A (normative): Abstract Test Suites (ATS).....		40
A.1	Version of specifications	40
A.2	IMS-CC ATS.....	41
A.2.1	Void.....	41
A.2.2	Void.....	41
A.2.3	Optional IP-CAN TTCN 2++ interface	41
Annex B (normative): Partial IXIT proforma		42
B.0	Introduction	42
B.1	Parameter values	42
B.1.1	SDP parameters for MT call test case	44
B.2	MMI Commands	45
Annex C (informative): Additional information to IXIT.....		47
C.1	Identification Summary	47
C.2	Abstract Test Suite Summary	47
C.3	Test Laboratory	48
C.3.1	Test Laboratory Identification.....	48
C.3.2	Accreditation status of the test service	48
C.3.3	Manager of Test Laboratory	48
C.3.4	Contact person of Test Laboratory	48
C.3.5	Means of Testing	49
C.3.6	Instructions for Completion.....	50
C.4	Client	50
C.4.1	Client Identification.....	50
C.4.2	Client Test Manager	50
C.4.3	Client Contact person	51
C.4.4	Test Facilities Required.....	51
C.5	System Under Test	52
C.5.1	SUT Information	52
C.5.2	Limitations of the SUT.....	52
C.5.3	Environmental Conditions.....	53
C.6	Ancillary Protocols.....	53
C.6.1	Ancillary Protocols 1.....	53
C.6.2	Ancillary Protocols 2.....	54
Annex D (informative): PCTR Proforma.....		55

Annex E (informative): TTCN3 style guide for 3GPP IMS ATS56
Annex F (informative): BNF Message Definitions.....57
Annex G (Normative): SIP Type Definitions and XSD References58
Annex H (informative): Change history59
History63

Foreword

This Technical Specification has been produced by the 3rd Generation Partnership Project (3GPP).

The contents of the present document are subject to continuing work within the TSG and may change following formal TSG approval. Should the TSG modify the contents of the present document, it will be re-released by the TSG with an identifying change of release date and an increase in version number as follows:

Version x.y.z

where:

- x the first digit:
 - 1 presented to TSG for information;
 - 2 presented to TSG for approval;
 - 3 or greater indicates TSG approved document under change control.
- y the second digit is incremented for all changes of substance, i.e. technical enhancements, corrections, updates, etc.
- z the third digit is incremented when editorial only changes have been incorporated in the document.

Introduction

The present document is 3rd part of a multi-part conformance test specification for UE and is *valid for 3GPP Release 5 and above*. The specification contains a TTCN design frame work and the detailed test specifications in TTCN for the UE conformance at the Gm reference point.

3GPP TS 34.229-1 [5] contains a conformance test description in prose.

3GPP TS 34.229-2 [6] contains a pro-forma for the UE Implementation Conformance Statement (ICS).

3GPP TS 34.229-3 the present document.

1 Scope

The present document specifies the protocol conformance testing in TTCN for the 3GPP User Equipment (UE) at the Gm interface.

The present document is the 3rd part of a multi-part test specification, 3GPP TS 34.229. The following TTCN test specification and design considerations can be found in the present document:

- the overall test suite structure;
- the testing architecture;
- the test methods and PCO definitions;
- the test configurations;
- the design principles, assumptions, and used interfaces to the TTCN tester (System Simulator);
- TTCN styles and conventions;
- the partial PIXIT proforma;
- the TTCN files for the mentioned protocols tests.

The Abstract Test Suites designed in the document are based on the test cases specified in prose (3GPP TS 34.229-1 [5]).

The present document is valid for UE implemented according 3GPP Release X, where X is the Release indicated on the spec's front page.

2 References

The following documents contain provisions which, through reference in this text, constitute provisions of the present document.

- References are either specific (identified by date of publication, edition number, version number, etc.) or non-specific.
- For a specific reference, subsequent revisions do not apply.
- For a non-specific reference, the latest version applies. In the case of a reference to a 3GPP document (including a GSM document), a non-specific reference implicitly refers to the latest version of that document in the same Release as the present document.
 - For a Release 5 UE, references to 3GPP documents are to version 5.x.y, when available.
 - For a Release 6 UE, references to 3GPP documents are to version 6.x.y, when available.

- [1] 3GPP TR 21.905: "Vocabulary for 3GPP Specifications".
- [2] 3GPP TS 34.123-1: "User Equipment (UE) conformance specification; Part 1: Protocol conformance specification".
- [3] 3GPP TS 34.123-2: "User Equipment (UE) conformance specification; Part 2: Implementation Conformance Statement (ICS) proforma specification".
- [4] 3GPP TS 34.123-3: "User Equipment (UE) conformance specification; Part 3: Abstract Test Suites (ATS)".
- [5] 3GPP TS 34.229-1: "Internet Protocol (IP) multimedia call control protocol based on Session Initiation Protocol (SIP) and Session Description Protocol (SDP); User Equipment (UE) conformance specification; Part 1: Protocol conformance specification".

- [6] 3GPP TS 34.229-2: "Internet Protocol (IP) multimedia call control protocol based on Session Initiation Protocol (SIP) and Session Description Protocol (SDP); User Equipment (UE) conformance specification; Part 2: Implementation Conformance Statement (ICS) specification".
- [7] 3GPP TS 34.108: "Common test environments for User Equipment (UE) conformance testing".
- [8] ISO/IEC 9646-1: "Information technology - Open systems interconnection - Conformance testing methodology and framework - Part 1: General concepts".
- [9] ISO/IEC 9646-7: "Information technology - Open systems interconnection - Conformance testing methodology and framework - Part 7: Implementation Conformance Statements".
- [10] ETSI ETS 300 406 (1995): "Methods for testing and Specification (MTS); Protocol and profile conformance testing specifications; Standardization methodology".
- [11] 3GPP TS 24.229: "IP Multimedia Call Control Protocol based on Session Initiation Protocol (SIP) and Session Description Protocol (SDP); Stage 3".
- [12] ETSI ES 201 873: "Methods for Testing and Specification (MTS); The Testing and Test Control Notation version 3".
- [13] IETF RFC 3320: "Signalling Compression (SigComp)".
- [14] IETF RFC 3485: "The Session Initiation Protocol (SIP) and Session Description Protocol (SDP) Static Dictionary for Signalling Compression (SigComp)".
- [15] IETF RFC 3486: "Compressing the Session Initiation Protocol (SIP)".
- [16] IETF RFC 3261: "SIP: Session Initiation Protocol".
- [17] IETF RFC 4566: "SDP: Session Description Protocol".
- [18] IETF RFC 1035: "Domain names - implementation and specification".
- [19] IETF RFC 1533: "DHCP Options and BOOTP Vendor Extensions".
- [20] IETF RFC 2131: "Dynamic Host Configuration Protocol".
- [21] IETF RFC 3315: "Dynamic Host Configuration Protocol for IPv6 (DHCPv6)".
- [22] IETF RFC 3319: "Dynamic Host Configuration Protocol (DHCPv6) Options for Session Initiation Protocol (SIP) Servers".
- [23] IETF RFC 3361: "Dynamic Host Configuration Protocol (DHCP-for-IPv4) Option for Session Initiation Protocol (SIP) Servers".
- [24] IETF RFC 3680: "A Session Initiation Protocol (SIP) Event Package for Registrations".
- [25] 3GPP TS 24.173: "IMS multimedia telephony communication service and supplementary services; Stage 3".
- [26] IETF RFC 4825: "The Extensible Markup Language (XML) Configuration Access Protocol (XCAP)".
- [27] IETF RFC 2616: "Hypertext Transfer Protocol – HTTP/1.1".
- [28] 3GPP TS 36.523-1: "Evolved Universal Terrestrial Radio Access (E-UTRA) and Evolved Packet Core (EPC); User Equipment (UE) conformance specification; Part 1: Protocol conformance specification".
- [29] 3GPP TS 36.523-2: "Evolved Universal Terrestrial Radio Access (E-UTRA) and Evolved Packet Core (EPC); User Equipment (UE) conformance specification; Part 2: Implementation Conformance Statement (ICS) proforma specification".
- [30] 3GPP TS 36.523-3: "Evolved Universal Terrestrial Radio Access (E-UTRA) and Evolved Packet Core (EPC); User Equipment (UE) conformance specification; Part 3: Test suites".

- [31] 3GPP TS 36.508: "Evolved Universal Terrestrial Radio Access (E-UTRA) and Evolved Packet Core (EPC); Common test environments for User Equipment (UE) conformance testing".
- [32] 3GPP TS 24.173: "IMS Multimedia telephony communication service and supplementary services; Stage 3".
- [33] 3GPP TS 24.109: "Bootstrapping interface (Ub) and network application function interface (Ua); Protocol details".
- [34] 3GPP TS 33.220: "Generic Authentication Architecture (GAA); Generic Bootstrapping Architecture".
- [35] 3GPP TS 33.222: "Generic Authentication Architecture (GAA); Access to network application functions using Hypertext Transfer Protocol over Transport Layer Security (HTTPS)".
- [36] 3GPP TS 24.623: "Extensible Markup Language (XML) Configuration Access Protocol (XCAP) over the Ut interface for Manipulating Supplementary Services".
- [37] RFC 2617: "HTTP Authentication: Basic and Digest Access Authentication".
- [38] RFC 3966: "The tel URI for Telephone Numbers".
- [39] RFC 2141: 'URN Syntax'.

3 Definitions and abbreviations

3.1 Definitions

For the purposes of the present document, the terms and definitions given in 3GPP TR 21.905 [1] and 3GPP TS 34.229-1 [5] apply.

3.2 Abbreviations

For the purposes of the present document, the abbreviations given in 3GPP TR 21.905 [1] and 3GPP TS 34.229-1 [5] apply.

4 Requirements on the TTCN development

A number of requirements are identified for the development and production of TTCN specification for 3GPP UE at the Gm reference point.

1. Top-down design, following 3GPP 34.229-1 [5], 3GPP TS 34.123-1 [2], 3GPP TS 34.108 [7].
2. A unique testing architecture and test method for testing all protocol layers of UE.
3. Uniform TTCN style and naming conventions.
4. Improve TTCN readability.
5. Using TTCN-3 (ES 201 873-1 [12]).
6. TTCN specification feasible, implementable and compilable.
7. Test cases shall be designed in a way for easily adaptable, upwards compatible with the evolution of the 3GPP core specifications and the future Releases.
8. The test declarations, data structures and data values shall be largely reusable.

9. Modularity and modular working method.
10. Minimizing the requirements of intelligence on the emulators of the lower testers.
11. Giving enough design freedom to the test equipment manufacturers.
12. Maximizing reuse of RFC BNF definitions from the relevant IETF core specifications.

In order to fulfil these requirements and to ensure the investment of the test equipment manufacturers having a stable testing architecture for a relatively long period, a unique testing architecture and test method are applied to the 3GPP UE protocol tests.

5 Test method and test model

5.1 Test method

5.2 IMS CC test model

The test model is shown in figure 2.

5.2.1 Ports interfacing to SS

In TTCN-3, ports are defined in all test components and in the Test System Interface. This is the equivalent of PCOs in TTCN-2. These ports then have to be mapped, or connected, to the SS at the start of each test.

5.2.1.1 Data ports

IMS_CC ATS in TTCN-3 simulates the SIP behaviour at the P_CSCF side. TTCN-3 communicates with the UE under test through four data ports and the emulations beneath. Each port shall be able to distinguish the use of one of the dual protocol stacks of IPv4 / IPv6.

The type of port (client or server) used to send or received a message will depend on the transport protocol selected for the testing, i.e. UDP or TCP.

- UDP case: The SS will send requests and responses to the UE from its client port. The SS will receive requests and responses from the UE on its server port.
- TCP case: The SS will receive requests from the UE and will send responses to those requests on its server port. The SS will send requests to the UE and will receive responses to those requests on its client port.

For SIP requests originated by the UE, the transport protocol in UL is selected by the UE. This information is extracted in the TTCN-3 and used in subsequent responses sent by the SS.

For SIP requests originated by the SS in DL UDP is used as transport protocol at the test For the purpose of test coverage, TCP is used in the specific test cases as specified.

NOTE: According to RFC 3261 [16] clause 18.1.1 the server side (UE) has to be able to cope with a maximum datagram size of 65,535 bytes (independent of any guideline to restrict the maximum size of UDP packets at the client side).

If no security associations have been set up, the unprotected client and server ports will be used. The security ports shall be used by the TTCN-3 authors when a security association has been established.

5.2.1.2 Security Associations Setup

Four unidirectional SAs are established between the UE and the SS:

SA1: port_uc to port_ps
SA2: port_pc to port_us

SA3: port_ps to port_uc
 SA4: port_us to port_pc

The first pair (SA1 and SA3) is for bidirectional traffic between port_uc and port_ps. The second pair (SA2 and SA4) is for bidirectional traffic between port_pc and port_us.

While TCP scenario will use all four SAs, in UDP, only two SAs are needed because there is no traffic from port_ps to port_uc nor from port_us to port_pc. Figure 1 shows one example of the use of ports and security association in UDP and TCP.

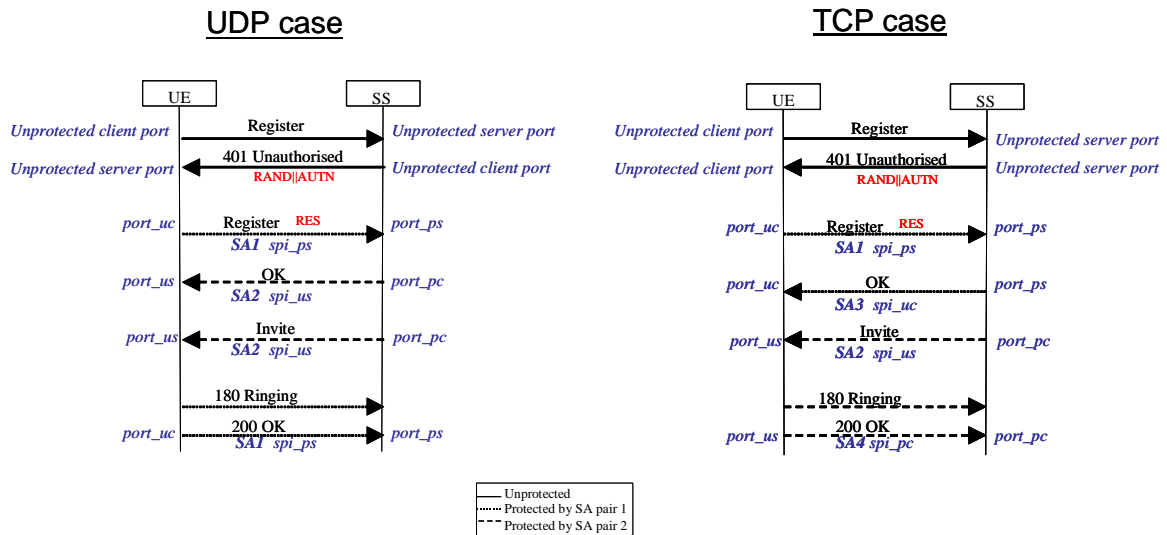

Figure 5.2.1.2-1: Use of port and SA in UDP and TCP

5.2.1.3 Control ports

IMS_CC ATS also controls the SS configuration and passes necessary parameters to the various emulation entities in the SS. This is done by ASPs through an **IP-CAN control port**, an **IP configuration port** and a **Signalling Compression control port**.

From the protocol stack point of view, SIP is an application layer protocol located above transport layer UDP / TCP which in turn use the services provided by the IP/IPsec layer. The IP packages are transmitted via the connected IP-CAN bearer, the EUTRA bearer, the UTRA bearer or the GERAN bearer. The emulations of these protocol layers in the SS shall be compliant with the relevant core specifications (3GPP and IETF).

The IP-CAN bearers are created, configured, modified and released though the ASP at the IP-CAN control port. The TTCN-3 codes shall also be able to control the UDP/IP/IPsec configurations and provide necessary parameters through the control ASPs.

The configuration of IP-CAN in the SS depends upon the technologies the UE supports. E-UTRA shall be configured for IMS test if E-UTRA technology is supported by the UE.

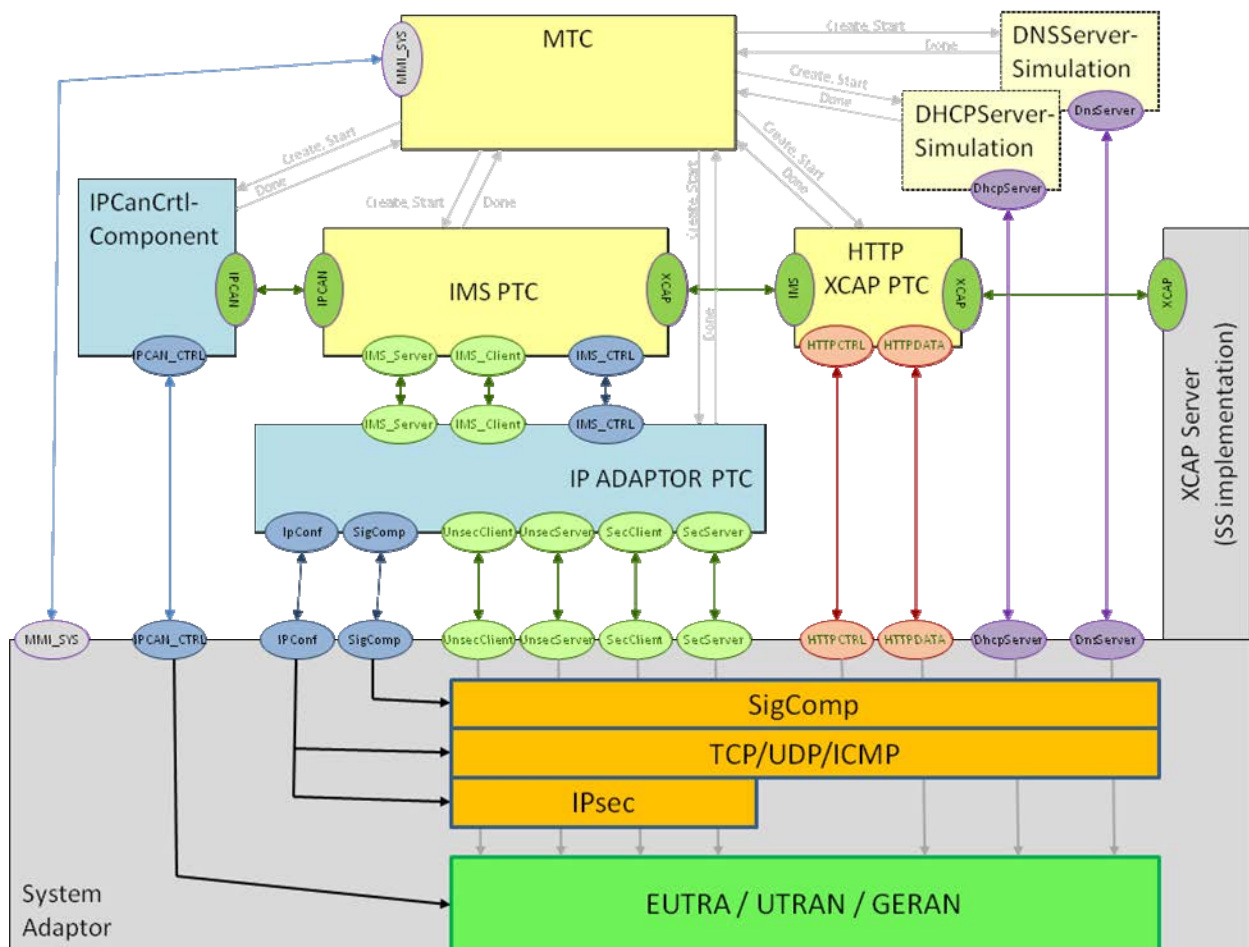

Figure 5.2.1.3-1: IMS CC test model

5.2.2 SAD

Security Association Database (SAD) shall be made accessible by the IPsec entity and contain sets of parameters corresponding to each security association. During registration/authentication, the UE and the SS will negotiate these parameters for setting up a security association. As the negotiation is carried out on SIP level (through SIP message exchanges), the resulting security parameters are obtained and stored in IMS_CC ATS. A number of ASPs are defined to convey these parameters from TTCN-3 codes to SAD. ASPs manipulating the SAD are also defined.

5.2.3 Network interface

Similar to the majority of TCP/IP stack implementations, a network interface (IF0, IF1, IF2, etc.) structure is used to connect the IP-CAN bearer to IP protocol entity. When the ASP for setting up an IP-CAN bearer is called via the IP-CAN control port, the SS shall connect the established radio access bearer to the relevant IF structure, in order to provide the radio bearer connectivity to the IP/IPsec layer. In order to ease maintenance, all IP-CAN control has been encapsulated into its own Parallel Test Component.

5.2.4 SigComp and related control port

SIP Compression is mandatory (clause 8 of 3GPP TS 24.229) and Signalling compression (RFC 3320, RFC 3485, RFC 3486, RFC4896, RFC5049) protocol is used for SIP compression. The SigComp entity in the model is used to carry out the compression/decompression functions. In the receiving direction of the SS, the SigComp entity will detect whether the incoming SIP message is compressed and, if so, decompress it. In the sending direction of the SS, the TTCN controls whether the outgoing SIP message is compressed through the SigComp control port. If while decompressing a message, decompression failure occurs, the message shall be discarded. The SigComp layer in the SS shall automatically find if a secure port or un-secure port is being used for transmission or reception of messages. If an

un-secure port is used for transmission, then as per clause 8 of 3GPP TS 24.229, it shall not include state creation instructions. If the state creation command is received in a compressed message on an un-secured port (clause 8 of 3GPP TS 24.229), a decompression failure shall be generated.

5.2.5 SIP TTCN 3 Codec

SIP is a text-based protocol, the messages exchanged between the UE and the SS are character strings. In TTCN-3 ATS the messages are structured to take the advantage of TTCN-3 functionality, and to make the debugging and maintenance of the ATS easier. When the TTCN-3 ATS sends a message to the UE, the SIP TTCN-3 codec converts the structured message to the corresponding character string then transfers it to the UE. When the SS receives a message from the UE, the TTCN-3 codec converts the received character string to the structured message and passes it to the TTCN-3 ATS.

5.2.6 DHCP and DNS data ports

The DHCP port is used for receiving the DHCP requests from the UE under test, and sending corresponding responses to the UE. The DNS port is used for receiving domain name resolution requests from the UE and sending the results back to the UE. The TTCN which implements the required DHCP and DNS server functions (only the functions necessary for testing purposes, not full functionality) will receive and send on these ports.

The DHCP and DNS server functionalities in the default test configuration are implemented as Parallel Test Components (PTCs).

5.3 Upper Tester (UT)

In order to support test automation and regression testing, there is an MMI port through which MMI commands (e.g. "Please initiate a call") are sent to an external entity of the system simulator. Implementations can customize the external entity according to their needs.

5.4 TTCN-3

TTCN is used as specification language. ES 201 873 [12] (TTCN-3) is applied to the notation.

5.5 Support of XCAP

MTSI supplementary services (TS 24.173) like communication barring (CB) and communication diversion (CDIV) require the XCAP protocol (RFC 4825) for transporting and manipulating XML documents in the network describing these services. Test cases for these services are specified in TS 34.229-1 clause 15. In order to support test case development, the test model shown in Figure 2 describes a PTC to handle HTTP requests from the UE and an external XCAP server as illustrated in Figure 3 below. There are specific ASPs to communicate with the XCAP server and for configuring the HTTP layer and for transferring data from the TTCN engine to the HTTP layer.

Figure 3 shows the Http/TLS layer of the test model within the SS connected to the TTCN component executing the testcases; and to the new BSF module (Bootstrapping Server Function, see TS 33.220) needed for implementing the GAA authentication.

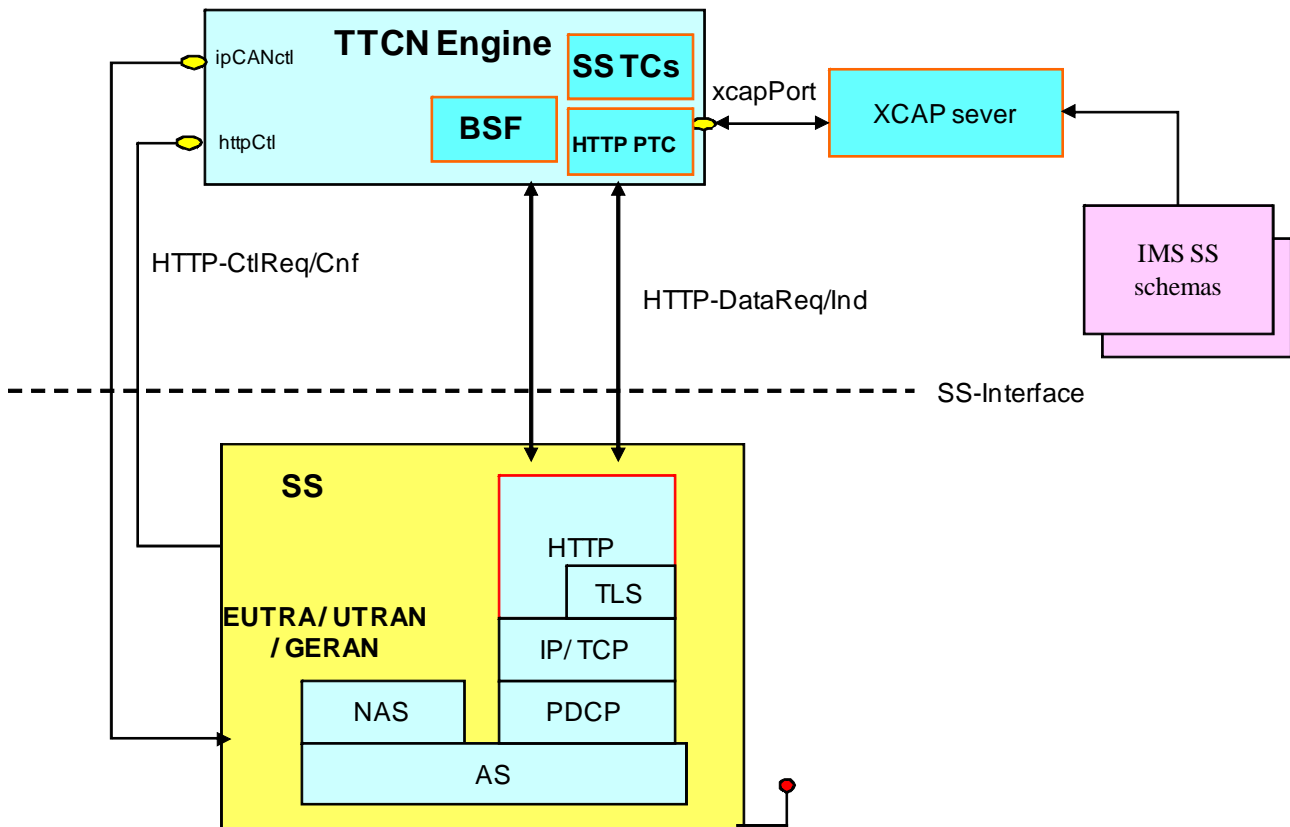

Figure 3: Extension to the Test Model to support XCAP

5.5.1

5.5.2 XCAP server functionality

RFC 4825 specifies the protocol for accessing user data in the XCAP server via HTTP requests. An HTTP request for an XCAP operation contains basically three components:

- Request line method, i.e. PUT, GET or DELETE
- Request line uri - The XCAP expression to be evaluated to access the XCAP document. The XCAP expression consists of the document selector followed by the separator '~~' followed by the node selector pointing to the user data to accessed or evaluated
- body - Describing the value (an xml fragment) referenced by the XCAP expression

Supplementary Services test cases (e.g. 34.229-1 test 15.1) verify the correct UE's XCAP signalling. Because TTCN is not suited for accessing and processing complex XML data, the XML processing relies on an external XCAP server simulation.

Example 1

In order to set terminating-identity-presentation for user sip:ob.stf160@etsi.org, the UE sends following HTTP request:

```
PUT http://XCAP-Server/simservs.ngn.etsi.org/users/sip%3Aob.stf160%40etsi.org/simservs.xml/~~/simservs/terminating-identity-presentation/%40active
Body: true
```

If successful, the XCAP server responds with

```
HTTP/1.1 200 OK
```

Example 2

To get the value of terminating-identity-presentation for user sip:ob.stf160@etsi.org, the UE sends following HTTP request:

```
GET http://XCAP-Server/simservs.ngn.etsi.org/users/sip%3Aob.stf160%40etsi.org/simservs.xml/~~/simservs/terminating-identity-presentation/%40active
```

If successful, the XCAP server responds with

```
HTTP/1.1 200 OK
Body: true
```

In this example

```
//XCAP-server/simservs.ngn.etsi.org/users/ sip%3Aob.stf160%40etsi.org/simservs.xml/-
Document selector for user sip:ob.stf160@etsi.org.
~~ - Document selector separator, see RFC 4825
/simservs/terminating-identity-presentation/%40active - Node selector pointing to the information in
the XCAP server to be accessed. This is an XPATH expression, see RFC 4825 section 6.3.
true - Is the xml fragment (in this case very simple) to be set as value of the XPATH expression
```

Following operations shall be implemented in the XCAP server, see RFC 4825.

GET - Returns the requested data as an XML fragment to be send to the UE

input parameters: charstring documentSelector, charstring xpathExpr

output parameters: error code (0 = noError)

returns: XML fragment or XML document

PUT - Builds an XML subtree or sets an attribute given by the xmlFragment at the position pointed by the xpath expression

input parameters: charstring documentSelector, charstring xpathExpr, charstring xmlFragment or xmlDocument

returns: error code (0 = noError)

DELETE - Deletes an XML subtree or sets an attribute given by the xmlFragment at the position pointed by the xpath expression

input parameters: charstring documentSelector, charstring xpathExpr

returns: error code (0 = noError)

RESET - This is not an XCAP operator but needed to generate in the XCAP server a default document for a particular user during the preamble

input parameter: charstring documentSelector

returns: error code (0 = noError)

Default simservs XML document referenced by the documentSelector:

```
<?xml version="1.0" encoding="UTF-8"?>
<simservs xmlns="http://uri.etsi.org/ngn/params/xml/simservs/xcap"
xmlns:xsi="http://www.w3.org/2001/XMLSchema-instance">
  <communication-waiting active="true"/>
  <originating-identity-presentation active="true"/>
  <originating-identity-presentation-restriction active="true">
    <default-behaviour>presentation-restricted</default-behaviour>
  </originating-identity-presentation-restriction>
  <terminating-identity-presentation active="true"/>
  <terminating-identity-presentation-restriction active="true">
    <default-behaviour>presentation-restricted</default-behaviour>
  </terminating-identity-presentation-restriction>
</simservs>
```

- The XCAP server simulation shall return different error codes to inform TTCN on the result of the operation:

0 - Success

1 - User document not found

2 - Invalid XCAP expression

3 - Invalid xmlFragment

4 - Invalid document (not complying to the XSD schema of the sub-document related to the particular XCAP service)

Further error codes are FFS

5.6 Extension of the Test Model to support 36.523-3 Interface

The IMS CC test cases can also be executed on top of the 36.523-3 test model. To support this approach, the following test model is used.

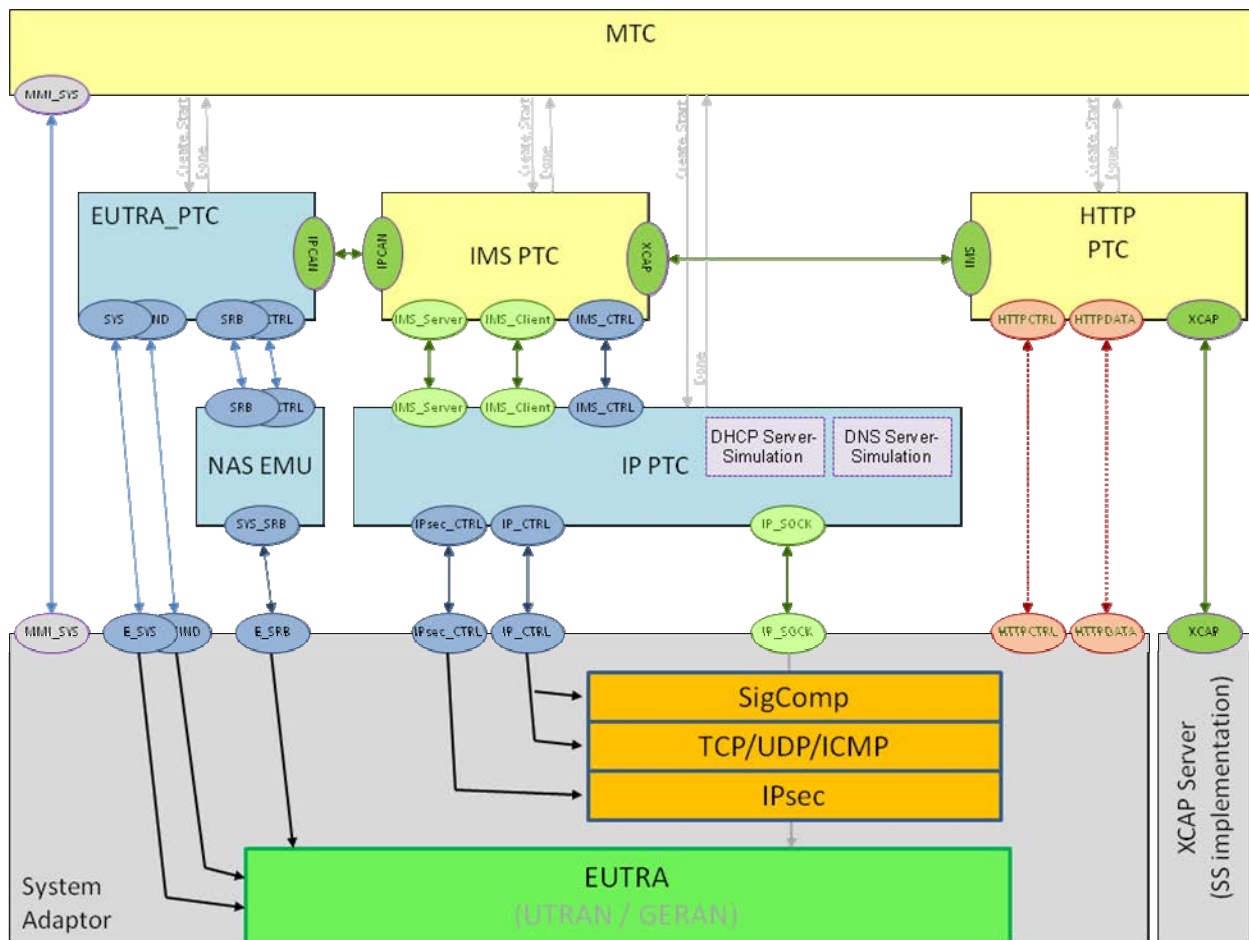

Figure 5.6-1: Extension to the Test Model to support 36.523-3 SS interface

The IMS CC test cases run on the IMS-PTC which control the IPCanEmu and the IP-PTC. IPCanEmu is responsible for cell setup and DRB establishment and the IP-PTC controls the IP related configurations. IPCanEmu and IP-PTC interface to the SS according to 36.523-3.

Clauses 4.2.4 and 4.2.5 of 36.523-3 describe the common handling of IP data in the 36.523 model regarding IMS signalling. In addition when a test case requires support of XCAP the SS needs to extend routing and handling of the IP data so that it can manage the security for the respective HTTP data, provide information of HTTP request and process information for HTTP responses according to ASP definitions in clause 6.4. The configuration of this extension is done by HttpCtlReq as defined in clause 6.4.

Further clarifications are FFS.

6 ASP definitions

6.1 Control ASP

ASPs for configuring/controlling the SS are defined to operate in a pair of ASPs, Req (request) ASP and Cnf (Confirm) ASP of the blocking mode. The TTCN-3 execution after sending a Req ASP shall wait (be blocked) for the Cnf ASP.

Because the IMS Test Suite is radio access technology independent, few parameters are passed from the TTCN-3. Therefore the exact configuration procedures used are determined by the implementation.

The PIXIT px_RANTech (see below) is set by the operator according to the technology the UE supports and is passed through the TTCN to the SS. This is defined as an enumerated type and is used to specify which platform the test is to be run on (e.g. GERAN, UTRA or E-UTRA). E-UTRA shall be chosen if it is supported by the UE.

6.1.1 Cell Control

Name	CreateCellReq	
Port	IPCANctl	
Comment	ASP type for creating a cell	
Parameter Name	Parameter Type	Comment
ranTech	RANTech	
primaryFrequencyBand	integer	
union { noSSAC, ssacBarringFactorVoice, ssacBarringFactorVideo }		Optional. Specific ac-Barring Factor
mccValue	hexstring (3)	Optional
mncValue	hexstring (2..3)	Optional

Name	CreateCellCnf	
Port	IPCANctl	
Comment	ASP type which returns the result of the execution of CreateCellReq	
Parameter Name	Parameter Type	Comment
status	Status	

Name	ReleaseCellReq	
Port	IPCANctl	
Comment	ASP type for releasing resources allocated to the cell	
Parameter Name	Parameter Type	Comment

Name	ReleaseCellCnf	
Port	IPCANctl	
Comment	ASP type which returns the result of the execution of ReleaseCellReq	
Parameter Name	Parameter Type	Comment
status	Status	

Name	RANTech	
Type	enumerated	
Parameters	GERAN, UTRA_FDD, UTRA_TDD, EUTRA_FDD, EUTRA_TDD, dummy1, dummy2	
Comment	Indicates the radio access network technology used for transport of SIP signalling messages over the air interface	

Name	Status	
Type	enumerated	
Parameters	success, failure, inconclusive	
Comment	Indicates the status result of the requesting ASP	

Name	ModifyCellReq	
Port	IPCANctl	
Comment	ASP type for modifying system information parameters in a cell	
Parameter Name	Parameter Type	Comment
union { noSSAC, ssacBarringFactorVoice, ssacBarringFactorVideo }		Optional. Specific ac-Barring Factor

Name	ModifyCellCnf	
Port	IPCANctl	
Comment	ASP type which returns the result of the execution of ModifyCellReq	
Parameter Name	Parameter Type	Comment
status	Status	

6.1.2 IdleUpdated

Name	IdleUpdatedReq	
Port	IPCANctl	
Comment	ASP type which requests the SS to bring the UE into an idle updated state and GMM or EMM registered	
Parameter Name	Parameter Type	Comment
ueAddress	IPAddress	UE address to be assigned via NAS signalling
bearerInfo	List of integers	Optional. For use in EUTRA to specify the default bearer to be used and possibly one or more dedicated bearers to be established in the preamble.
isEmergency	Boolean	Optional. To indicate if this is an emergency attach
withUICC	Boolean	Optional. To indicate if the UE has a UICC

Name	IdleUpdatedCnf	
Port	IPCANctl	
Comment	ASP type which returns the result of the execution of IdleUpdatedReq	
Parameter Name	Parameter Type	Comment
status	Status	

Name	DetachReq	
Port	IPCANctl	
Comment	ASP type which requests the SS to bring the UE into detached state	
Parameter Name	Parameter Type	Comment
moFlag	Boolean	Set to true if th SS is requested to accept a mobile originated detach. Set to false if the SS is requested to initiate the detach

Name	DetachCnf	
Port	IPCANctl	
Comment	ASP type which returns the result of the execution of DetachReq	
Parameter Name	Parameter Type	Comment
status	Status	

Name	HandoverReq	
Port	IPCANctl	
Comment	ASP type which requests the SS to allow the UE to handover to another RAT	
Parameter Name	Parameter Type	Comment
ranTech	RANTech	Info to which RAT the UE will handover
handoverType	HandoverType	Type of handover

Name	HandoverCnf	
Port	IPCANctl	
Comment	ASP type which returns the result of the execution of HandoverReq	
Parameter Name	Parameter Type	Comment
status	Status	

Name	HandoverType	
Type	enumerated	
Parameters	ho_csfb, ho_reselection	
Comment	Indicates the type of handover to be performed	

6.1.3 PDPContext

Name	AddPDNReq	
Port	IPCANctl	
Comment	ASP type which requests the SS to be prepared to establish a new PDN	
Parameter Name	Parameter Type	Comment
ueAddress	IPAddress	UE address to be assigned via NAS signalling
isEmergencyPDN	Boolean	To indicate if this is an emergency bearer

Name	AddPDNCnf	
Port	IPCANctl	
Comment	ASP type which returns the result of the execution of AddPDNReq	
Parameter Name	Parameter Type	Comment
status	Status	

Name	PCORequest	
Port	IPCANctl	
Comment	ASP type which returns the contents of the ProtocolConfigurationOptions IE received in the ActivatePDPContextRequest / EPS Bearer Request to the TTCN	
Parameter Name	Parameter Type	Comment
configOptList	ConfigOptList	
bearerContextId	integer	

Name	PCOResponse	
Port	IPCANctl	
Comment	ASP type which sends back the ProtocolConfigurationOptions IE to the SS.	
Parameter Name	Parameter Type	Comment
configOptList	ConfigOptList	
bearerContextId	integer	

Name	DedicatedBearerReq	
Port	IPCANctl	
Comment	ASP type which in requests the SS to establish one or more secondary PDP context / dedicated bearers; or informs the SS to expect the UE to request one or more secondary PDP context / dedicated bearers. Includes the bearer info to be configured and media ports to be used	
Parameter Name	Parameter Type	Comment
bearerInfoList	{{bearerContextId, bearerInfo, mediaPort}}	
moFlag	boolean	Set to true if the SS is requested to accept a mobile initiated dedicated bearer establishment procedure; set to false if the SS is to establish the dedicated bearer.

Name	DedicatedBearerCnf	
Port	IPCANctl	
Comment	ASP type which returns the result of the execution of DedicatedBearerReq, when it is completed	
Parameter Name	Parameter Type	Comment
status	Status	

Name	ModifyBearerReq	
Port	IPCANctl	
Comment	ASP type which informs the SS to expect the UE to request to modify an existing PDP context / Dedicated Bearer. Includes the bearer info for this to be modified to	
Parameter Name	Parameter Type	Comment
bearerContextId	integer	
bearerInfo	integer	

Name	ModifyBearerCnf	
Port	IPCANctl	
Comment	ASP type which returns the result of the execution of ModifyBearerReq, when it is completed	
Parameter Name	Parameter Type	Comment
status	Status	

Name	DeactivateBearerReq	
Port	IPCANctl	
Comment	ASP type which requests the SS deactivate the indicated PDP context. A value of bearerContextId = 0 indicates that all existing PDP contexts are to be deactivated.	
Parameter Name	Parameter Type	Comment
bearerContextId	integer	
molinitiated	boolean	Flag indicating if the PDP context deactivation is initiated by the UE

Name	DeactivateBearerCnf	
Port	IPCANctl	
Comment	ASP type which returns the result of the execution of DeactivateBearerReq	
Parameter Name	Parameter Type	Comment
status	Status	

Name	BearerInfo
Type	integer
Comment	References the RAB to be configured. This is RAN independent and can be added to/reduced as required

This is simply a list of RAB identifiers. It is expected, in the future, for these identifiers to equate to specific RAB requirements, for all available radio access technologies See clause 8.1 for more information.

Name	ConfigOptList
Type	set of ConfigOpt
Comment	Used to contain the protocol configuration options IE used in the PDP context messages

Name	ConfigOpt
Type	octetstring
Parameter Name	Parameter Type
ContainerId	octetstring [2]
ContainerLength	octetstring [1]
ContainerContents	octetstring optional

6.1.4 IP Configuration

Name	InstallKeyReq	
Port	IPconf	
Comment	ASP type which installs the keys into the IP layer in the SS	
Parameter Name	Parameter Type	Comment
MD5_96Key	bitstring	length (128)
SHA_1_96Key	bitstring	length (160)
DES_EDE3_CBCKey	bitstring	length (192)
AES_CBCKey	bitstring	length (128)

Name	InstallKeyCnf	
Port	IPconf	
Comment	ASP type which returns the result of the execution of InstallKeyReq	
Parameter Name	Parameter Type	Comment
status	Status	

Name	AssignIPAddrReq	
Port	IPconf	
Comment	ASP type which assigns the IP address to the IP layer in the SS	
Parameter Name	Parameter Type	Comment
p_cscf_Addr	IPAddr	
dhcp_Addr	IPAddr	
dns_Addr	IPAddr	
ue_Addr	IPAddr	
peerUE_Addr	IPAddr	

Name	AssignIPAddrCnf	
Port	IPconf	
Comment	ASP type which returns the result of the execution of AssignIPAddrReq	
Parameter Name	Parameter Type	Comment
status	Status	

Name	IPAddr
Type	charstring
Comment	in either colon separated or dotted decimal format

Name	ReleaseIPConfigurationReq	
Port	IPconf	
Comment	ASP type which releases the IMS IP layer configurations including Security Associations. This ASP is meant to be used when starting a new test case to make sure that the IP layer is in a well defined initial state irrespective of the execution of previous tests.	
Parameter Name	Parameter Type	Comment
-	-	No parameters

Name	ReleaseIPConfigurationCnf	
Port	IPconf	
Comment	ASP type which returns the result of the execution of ReleaseIPConfigurationReq	
Parameter Name	Parameter Type	Comment
status	Status	

Name	AddPCSCFAddrReq	
Port	IPconf	
Comment	ASP type which configures a new address of the P-CSCF component in the IP layer in the SS	
Parameter Name	Parameter Type	Comment
p_cscf_Addr	IPAddr	New IP address of P-CSCF component to be simulated

Name	AddPCSCFAddrCnf	
Port	IPconf	
Comment	ASP type which returns the result of the execution of AddPCSCFAddrReq	
Parameter Name	Parameter Type	Comment
status	Status	

Name	SignallingCompressionReq	
Port	SigComp	
Comment	ASP type which starts/stops signalling compression of messages	
Parameter Name	Parameter Type	Comment
startCompression	boolean	

Name	SignallingCompressionCnf	
Port	SigComp	
Comment	ASP type which returns the result of the execution of SignallingCompressionReq	
Parameter Name	Parameter Type	Comment
status	Status	

Name	RcvdCompartmentId	
Port	SigComp	
Comment	ASP type which feeds back the Compartment Id back to the Sigcomp layer, extracted from the last received message, used by SigComp layer to store any state appropriately.	
Parameter Name	Parameter Type	Comment
compartmentId	charstring	Call-Id of the SIP message will be used as compartment Id

Name	DecompFailureType	
Type	enumerated	
Parameters	stateCreation,dummy1,dummy2,dummy3	
Comment	Indicates the mechanism through which decompression failure errors shall be inserted during compressing message stateCreation: This type indicates, decompression failure shall be generated by inserting "State Creation" instructions in DL messages sent on unsecured SS Port (clause 8 of 3GPP TS 24.229)	

Name	UpdateRemotePCSCFPortNumberReq	
Port	IPconf	
Comment	ASP type use by TTCN to reconfigure P-CSCF server and client ports to contact the UE at given port number	
Parameter Name	Parameter Type	Comment
uePortNumber	integer	

Name	UpdateRemotePCSCFPortNumberCnf	
Port	IPconf	
Comment	ASP type which the result of the execution of UpdateRemotePCSCFPortNumberReq	
Parameter Name	Parameter Type	Comment
status	Status	

6.1.5 SA Database

Name	DoubleAddSADReq	
Port	IPconf	
Comment	ASP type which sets two entries of SAD in the SS	
Parameter Name	Parameter Type	Comment
sa1	SA	
sa2	SA	

Name	DoubleAddSADCnf	
Port	IPconf	
Comment	ASP type which returns the result of the execution of DoubleAddSADReq	
Parameter Name	Parameter Type	Comment
status	Status	

Name	DelSADReq	
Port	IPconf	
Comment	ASP type which deletes the SAD entries	
Parameter Name	Parameter Type	Comment
spi1	SPI	
spi2	SPI	optional
spi3	SPI	optional
spi4	SPI	optional
spi5	SPI	optional
spi6	SPI	optional
spi7	SPI	optional
spi8	SPI	optional
spi9	SPI	optional

Name	DelSADCnf	
Port	IPconf	
Comment	ASP type which returns the result of the execution of DelSADReq	
Parameter Name	Parameter Type	Comment
status	Status	

Name	SA
Port	IPconf
Comment	ASP type which sets a single entry of parameters for a security association in the SS
Parameter Name	Parameter Type
spi	SPI
srcIPAddr	IPAddr
desIPAddr	IPAddr
srcUDPport	integer
desUDPport	integer
intAlgo	IntAlgo
ciphAlgo	CiphAlgo

Name	IntAlgo
Type	enumerated
Parameters	hmac_md5_96, hmac_sha_1_96
Comment	Integrity algorithms

Name	CiphAlgo
Type	enumerated
Parameters	des_ed3_cbc, aes_cbc, nociph
Comment	Ciphering algorithms, "nociph" means no ciphering

Name	SPI
Type	integer (0..4294967295)
Comment	security parameter index for IPsec

6.1.6 Emergency CS Call

Name	ExpectEmergencyCSCall	
Port	IPCANctl	
Comment	ASP type which informs the SS to expect the UE to request an emergency CS call	
Parameter Name	Parameter Type	Comment

Name	EmergencyCSCallActive	
Port	IPCANctl	
Comment	ASP type which returns the result of the execution of ExpectEmergencyCSCall when it is in call active state	
Parameter Name	Parameter Type	Comment
status	Status	

Name	ReleaseCSCallReq	
Port	IPCANctl	
Comment	ASP type which requests the SS to release the CS call previously established during ExpectEmergencyCSCall	
Parameter Name	Parameter Type	Comment

Name	ReleaseCSCallCnf	
Port	IPCANctl	
Comment	ASP type which returns the result of the execution of ReleaseCSCallReq	
Parameter Name	Parameter Type	Comment
status	Status	

6.1.7 CS Voice Call

Name	CSCallReq	
Port	IPCANctl	
Comment	ASP type which informs the SS to establish a CS voice call with the UE	
Parameter Name	Parameter Type	Comment
moFlag	Boolean	Set to true if the SS is requested to accept a mobile originated CS voice call; Set to false if SS is requested to establish a CS voice call
phoneNumber	charstring	Optional. The phone number to be signalled to the UE in the mobile terminated case

Name	CSCallCnf	
Port	IPCANctl	
Comment	ASP type which returns the result of the execution of CSCallReq when it's in call active state	
Parameter Name	Parameter Type	Comment
status	Status	

6.2 IMS-CC Data ASP definitions

6.2.1 ASP_DataRequest

Name	ASP_DataRequest	
Port	DataPort	
Comment	ASP type for receiving/sending SIP Request Messages	
Parameter Name	Parameter Type	Comment
sigCompInfo	SigCompInfo	OPTIONAL. Information for/from SigComp layer. Absence means compression is/shall be not applied in received/send message.
portInfo	SSPortInfo	
msg	union {REGISTER_Request, INVITE_Request, OPTIONS_Request, BYE_Request, CANCEL_Request, ACK_Request, PRACK_Request, NOTIFY_Request, SUBSCRIBE_Request, PUBLISH_Request, UPDATE_Request, REFER_Request, MESSAGE_Request}	SIP message

6.2.2 ASP_DataResponse

Name	ASP_DataResponse	
Port	DataPort	
Comment	ASP type for receiving/sending SIP RESPONSE Message	
Parameter Name	Parameter Type	Comment
sigCompInfo	SigCompInfo	OPTIONAL. Information for/from SigComp layer. Absence means compression is/shall be not applied in received/send message.
portInfo	SSPortInfo	
msg	Response	SIP RESPONSE message

Name	SigCompInfo	
Type	Union	
Parameter Name	Parameter Type	Comment
compartmentId	charstring	Used for Sending messages from TTCN. To be used by SigComp Layer
isCompressed	boolean	Used for received messages. If set, means received message was compressed

Name	SSPortInfo	
Type	record	
Parameter Name	Parameter Type	Comment
ipAddr	IPAddr	IP address of simulated network node
transportProtocol	TransportProtocol	

Name	TransportProtocol	
Type	enumerated	
Parameters	UDP, TCP	

6.3 Ut ASP definitions

Name	MMIMessage	
Port	MMIPort	
Comment	ASP type for sending messages to upper tester	
Parameter Name	Parameter Type	Comment
mmiMessage	charstring	Action required by upper tester

6.4 HTTP Layer ASP definitions

HTTP Layer ASPs are applicable to clause 5.2.1.3 and 5.6.

Name	HttpRoutingInfo	
Comment	Routing info to distinguish HTTP data for XCAP server and BSF.	
Parameter Name	Parameter Type	Comment
serverAddr	Charstring	IP address of simulated server
xcapServerPort	Integer	Port number of simulated server

Name	HttpDataInd	
Port	HTTPDATA	
Comment	ASP type for sending a message from the http layer to the TTCN engine. It transports relevant information of a http Request from the UE to the Tester.	
Parameter Name	Parameter Type	Comment
routingInfo	HttpRoutingInfo	to distinguish BSF and XCAP server
httpRequest	HttpRequest	See below

Name	HttpRequest	
Comment		
Parameter Name	Parameter Type	Comment
requestLine	HttpRequestLine	Request-Line in RFC 2616 [27] clause 5.1
authorization	Authorization	Authorization in RFC 2616 [27] clause 14.8 (optional; NOTE 1)
contentType	ContentType	Content-Type in RFC 2616 [27] clause 14.17 (optional, NOTE 1)
x3GPPIntendedIdentity	charstring	3GPP TS 24.109 [33] clause G.2 (optional)
messageBody	charstring	MTSI XCAP Message (optional)
NOTE 1: Same type definition as for SIP type definitions.		

Name	HttpRequestLine	
Comment	request line according to RFC 2616 [27] clause 5.1.	
Parameter Name	Parameter Type	Comment
method	charstring	
uri	charstring	XCAP selection expression, RFC 4825 [26]
version	charstring	

Name	HttpDataReq	
Port	HTTPDATA	
Comment	ASP type for sending messages from the TTCN engine to the http layer. It transports information needed by the http layer to generate a http Response to the UE.	
Parameter Name	Parameter Type	Comment
routingInfo	HttpRoutingInfo	to distinguish BSF and XCAP server
httpResponse	HttpResponse	See below

Name	HttpResponse	
Comment		
Parameter Name	Parameter Type	Comment
statusLine	HttpStatusLine	Status-Line in RFC 2616 [27] clause 6.1
wwwAuthenticate	WWWAuthenticate	WWW-Authenticate in RFC 2616 [27] clause 14.47 (optional; NOTE 1)
authenticationInfo	AuthenticationInfo	Authentication-Info in RFC 2617 [37] clause 3.2.3 (optional; NOTE 1)
contentType	ContentType	Content-Type in RFC 2616 [27] clause 14.17 (optional; NOTE 1)
expires	Expires	Expires in RFC 2616 [27] clause 14.21 (optional; NOTE 1)
messageBody	charstring	MTSI XCAP Message (XML document or XML fragment) (optional)
NOTE 1: Same type definition as for SIP type definitions.		

Name	HttpStatusLine	
Comment	request line according to RFC 2616 [27] clause 5.1.	
Parameter Name	Parameter Type	Comment
version	charstring	
code	charstring	
reasonPhrase	charstring	

Name	HttpCtlReq	
Port	HTTPCTRL	
Comment	ASP type to configure the http layer When any of the optional fields is omitted the SS shall continue with the previous configuration of this field.	
Parameter Name	Parameter Type	Comment
authenticationMechanism	enumerated {noAuthentication, httpDigestAuthentication, gaaAuthentication}	Authentication mechanism: noAuthentication: no authentication (NOTE 3) httpDigestAuthentication: HTTP digest authentication according to 24.623[36] clause 5.2.3.2 and RFC 2617 [37] gaaAuthentication: GAA based authentication according to 33.222 [35] and 24.109 [33]
tlsInfo	TLSInfo	Description of the TLS connection to be used (optional)
xcapServer	HttpRoutingInfo	IP address and port of simulated XCAP server (optional)
bsfServer	HttpRoutingInfo	IP address and port of simulated BSF server (optional)
drblInfo	IP_DrblInfo_Type	(optional) NOTE 1, 2
NOTE 1: Whether this parameter is used by the SS depends on SS implementation and on which test model is used; if the SS does not need the information it may just ignore it.		
NOTE 2: 'IP_DrblInfo_Type' is imported from common definitions of the LTE model (TS 36.523-3 [30]).		
NOTE 3: in general 'no authentication' is not applicable to conformance testing		

Name	TLSInfo	
Comment		
Parameter Name	Parameter Type	Comment
tlsType	enumerated {noTLS, pskTLS, certTLS}	Type of TLS connection to be used (if any)
psk	octetstring	Pre shared key for TLS ciphering
cipherSuite	enumerated {noCipher, psk_3DES_EDE_CBC_SHA, psk_AES_128_CBC_SHA}	Cipher suite to be used

Name	HttpCtlCnf	
Port	HTTPCTRL	
Comment	ASP type to confirm HttpCtlReq	
Parameter Name	Parameter Type	Comment
errorInfo	charstring	string indicating a system error (optional)

6.5 XCAP server ASP definitions

XCAP Layer ASPs are applicable to clause 5.2.1.3 and 5.6.

Name	XCAPReq	
Port	XCAP	
Comment	ASP type for sending a request to the external XCAP server	
Parameter Name	Parameter Type	Comment
method	charstring	GET, PUT, DELETE or RESET
xcapExpression	charstring	XCAP expression sent by the UE in its http request line
xmlBody	charstring	XML fragment sent by the UE in its http body(optional)
contentType	charstring	To distinguish whether the xmlBody is an XML fragment or an XML document (optional)

Name	XCAPRsp	
Port	XCAP	
Comment	ASP type for sending the response to the XCAPReq from the XCAP server to TTCN	
Parameter Name	Parameter Type	Comment
errorInfo	charstring	string indicating a system error (optional)
xmlFragment	charstring	Result returned by the XCAP server
contentType	charstring	To distinguish whether the xmlBody is an XML fragment or an XML document

6.6 Positioning / ASP definitions

Name	UpdateUELocationInfoReq	
Port	IPCANctl	
Comment	ASP to trigger in the SS the execution of test function Update UE Location Information (TS 36.509 clause 5.5.2)	
Parameter Name	Parameter Type	Comment
ellipsoidPointWithAltitude	O8_Type	See 56.509 clause 6.12
horizontalVelocity	O3_Type	See 56.509 clause 6.12
gnnTodMsec	O3_Type	See 56.509 clause 6.12

Name	UpdateUELocationInfoCnf	
Port	IPCANctl	
Comment	ASP type which returns the result of the execution of UpdateUELocationInfoReq	
Parameter Name	Parameter Type	Comment
status	Status	

7 Codec definitions for IP User Data

7.1 Introduction

SIP is a text-based protocol, thus the message exchange between the UE and the SS are pure character strings. In the TTCN-3 ATS the messages are structured and optimized to take the advantage of TTCN-3 functionality, and to make the debugging and maintenance of the ATS easier.

7.2 General Aspects

IP user data for IMS conformance testing can be distinguished into:

1. text based: SIP (including SDP and XML messages), HTTP (see clause 7.4)
2. octetstring based: DHCP, DHCPv6, DNS (see clause 7.4)

In TTCN the following encoding information is used for user data:

Table 7.2-1

Type definitions	Encoding
SMS Types	Tabular notated (see note 1)
DHCPv4-Codec	Tabular notated (see note 1)
DHCPv6-Codec	Tabular notated (see note 1)
DNS-Codec	Tabular notated (see note 1)
SIPCodec	(see clause 7.3)
SDPCodec	(see clause 7.3)
HttpCodec	(see clause 7.3)

NOTE 1: Tabular notated is performed by concatenation of all the present fields in the TTCN-3 template.

NOTE 2: Encoding information is only needed for type definitions of peer-to-peer signalling; encoding of ASPs used for system configuration or as co-ordination messages between PTCs is out of scope for this document.

7.3 Requirements on abstract message syntax for IMS (SIP, SDP)

7.3.1 Type definition - Syntax / Semantic aspects

All given defined BNF grammars (e.g. the ABNF of RFC 3261) are unique. Thus the syntax tree for each syntactically correct message derived with these grammars are unique too and the parts of a message can be uniquely identified (represented) by the terminal phrase belonging to a non terminal symbol and its derivation path in the syntax tree.

The syntax tree of all given messages can be used to uniquely identify and describe the parts of the messages. The leaves are the part of every message and the nodes from the root to the leaves represent the sequence of rules to be applied to derive that part

The IMS/SIP root message type is an ordered structured type, which is represented as a record type in TTCN-3. For each grammar rule of the ABNF a TTCN-3 record type is declared with the specific name of the rule. The following rules are applied to the fields within a record:

- A non-terminal symbol is declared as a record type for this symbol.
- The order of the symbols in the rule are represented by an equal order of the fields.
- Repetitions are declared as 'set of' or 'record of' types.
- Options are represented as optional record/set fields.
- Alternatives are declared as union types.

7.3.2 Deviations of the type definition semantic

- Most of the 'literals' of a message (for example: the string "Via" or "v" in the message header fields) are not represented.
- The TTCN-3 charstring type is used where we stop structuring even if the ABNF uses structured types. More details found in clause 8.3.3.
- Wherever possible parts are mapped to their best type representation, e.g. DIGIT based rules are mapped to integer type not to a charstring type.

- All of the following delimiters (including preceding or following whitespace) defined by the ABNF grammar to separate the parts of a message are not represented (see note).

```

STAR      = SWS "*" SWS ; asterisk
SLASH     = SWS "/" SWS ; slash
EQUAL     = SWS "=" SWS ; equal
LPAREN    = SWS "(" SWS ; left parenthesis
RPAREN    = SWS ")" SWS ; right parenthesis
RAQUOT    = ">" SWS ; right angle quote
LAQUOT    = SWS "<"; left angle quote
COMMA     = SWS "," SWS ; comma
SEMI      = SWS ";" SWS ; semicolon
COLON     = SWS ":" SWS ; colon
LDQUOT    = SWS DQUOTE; open double quotation mark
RDQUOT    = DQUOTE SWS ; close double quotation mark
HCOLON    = *( SP / HTAB ) ":" SWS
SP        = single space
HTAB     = tab
SWS      = sep whitespace

```

NOTE: If they are present within a pure charstring they will be handled like a normal character and are still included.

- Messages which are not of interest to the test suite are left undecoded as a charstring and will not be further structured.

7.3.3 Additional requirements for codec implementations (SIP/IMS Message)

The SIP/IMS codec is based on a normalized encoding which is always produced by an encoder. Decoder implementations, however, have to handle normalization before, or when constructing the structured message value, e.g. long versus compact form, whitespace compression, delimiter removal, same header grouping, etc. All these aspects will be handled in the next clause.

7.3.3.1 Differences between BNF - TTCN-3 Type Mapping

In normal cases the mapping is straight forward. Below you find the exceptions, including potential examples.

- The root message type is not a SIP-message but directly a Request or Response type which is represented as a TTCN-3 record. All Method - Message names (INVITE, BYE, ACK etc.) and all message header field names (To, From, CallID, CSeq, Via etc.) are mapped to an enumerated type in TTCN-3 to simplify the extension of new headers. During encoding, the long-form of these message header fields is always used. The respective field in the header type is restricted to values which are allowed.

BNF rules of RFC		TTCN-3 Type Mapping
SIP-message =	Request / Response	type record REGISTER_Request {...}, type record INVITE_Request {...}, type record PRACK_Request {...}, type record NOTIFY_Request {...}, type record UPDATE_Request {...}, ... type record Response {...}

Method =	INVITEm / ACKm / OPTIONSm / BYEm / CANCELm / REGISTERm / ...	type enumerated Method { ACK_E, BYE_E, CANCEL_E, INVITE_E, OPTIONS_E, REGISTER_E, ...}
----------	--	---

- The structure of the message header fields are mapped to a "set " type in TTCN-3, because the order of these header fields is not mandatory. There is an Unknown Header List given in the type system to decode unknown headers with ID and Value.

message-header = (... / Contact / Content-Disposition ... / Via / Warning / WWW-Authenticate / extension-header) CRLF	type set MessageHeader { ... Contact contact optional, ContentDisposition contentDisposition optional, ... Via via, Warning warning optional, WwwAuthenticate wwwAuthenticate optional, UndefinedHeader_List undefinedHeader_List optional }
--	---

- The various parameter lists defined in the BNF are mapped and combined into three different TTCN-3 sets of generic-param types. These types differ only in their name: SemicolonParam_List, AmpersandParam_List, CommaParam_List to distinguish between the relevant separators.

uri-parameters = *(";" uri-parameter)	type set of GenericParam SemicolonParam_List;
Authentication-Info = "Authentication-Info" HCOLON ainfo *(COMMA ainfo)	type record AuthenticationInfo { FieldName fieldName(AUTHENTICATION_INFO_E), CommaParam_List ainfo }
ainfo = nextnonce / message-qop / response-auth / cnonce / nonce-count	type set of GenericParam CommaParam_List;
Headers = "?" header *("&" header)	type set of GenericParam AmpersandParam_List;

- Any more specific parameter rule (e.g. uri-param, user-param, lr-param , digest-cls, etc.) is simplified to the generic-param rule which will be mapped as a record structure of two charstrings (ID and paramValue). This is equivalent to a token with an optional generic value (token [EQUAL gen-value]).

digest-cls = realm / domain / nonce / opaque / stale / algorithm / qop-options / auth-param	type record GenericParam { charstring id , charstring paramValue optional }
---	---

- In addition to the pure charstring as a base type, the TTCN-3 type system provides base integer types which are unrestricted to the model e.g. the portField, CSeq number, maxForward digit.

user = 1*(unreserved / escaped / user-unreserved) telephone-subscriber as defined in RFC 2806	charstring
password = *(unreserved / escaped / "&" / "=" / "+" / "\$" / " ,")	charstring

Port =	1*DIGIT	integer
Status-Code =	Informational / Redirection / Success / Client-Error / Server-Error / Global-Failure / extension-code	integer

- Where the same header type can appear multiple times within a message, they will be decoded as a single header field, with multiple list elements. The order of appearance of the headers will be preserved within the header list value.

Contact =	("Contact" / "m") HCOLON (STAR / (contact-param *(COMMA contact-param)))	type record Contact { FieldName fieldName(CONTACT_E), ContactBody contactBody }
contact-param =	(name-addr / addr-spec) *(SEMI contact-params)	type record ContactAddress { Addr_Union addressField, SemicolonParam_List contactParams optional } type union ContactBody { charstring wildcard, ContactAddress_List contactAddresses } Used in type set of ContactAddress ContactAddress_List;

- The BNF (clause 7.3.1 Header Field Format RFC 3261 [16]) specifies that several WWW or Proxy Authentication/Authorization headers should not be combined into a single header; however they will be decoded into such in the codec. If these need to be sent downlink then a new, 'raw' (pure charstring) message type will be introduced.

Authorization =	"Authorization" HCOLON credentials	type record Authorization { FieldName fieldName(AUTHORIZATION_E), Credentials body }
Credentials =	("Digest" LWS digest-response) / other-response	type union Credentials { CommaParam_List digestResponse, OtherAuth otherResponse }

- The different schemes (sip, sips, tel, fax, absoluteUri) in the SIP URI are all handled via the same type definition. The union 'UriComponents' can be enhanced to support further specific URI formats. Nevertheless it is possible to use the 'other' branch of 'UriComponents' for any other URI format in which case the charstring shall contain the URI without the scheme and the first '!'.

Request-URI =	SIP-URI / SIPS-URI / absoluteURI	type record SipUriComponents { // sip-uri acc. to RFC 3261 [16] cl. 19.1 UserInfo userInfo optional, HostPort hostPort }
with		
SIP-URI =	"sip:" [userinfo] hostport uri-parameters [headers]	type record TelUriComponents { // tel-uri acc. to RFC 3966 [38] charstring subscriber }
and		type record UrnUriComponents { // urn-uri acc. to RFC 2141 [39] charstring namespaceId, // e.g. "service" charstring namespaceSpecificString // e.g. "sos" }
SIPS-URI =	"sips:" [userinfo] hostport uri-parameters [headers]	type union UriComponents { SipUriComponents sip, // scheme: "sip" or sips" TelUriComponents tel, // scheme: "tel" UrnUriComponents urn, // scheme: "urn" charstring other }
and		
absoluteURI =	scheme ":" (hier-part / opaque-part)	type record SipUri { { charstring scheme , UriComponents components, SemicolonParam_List urlParameters optional, AmpersandParam_List headers optional }type record SipUri { charstring scheme , UserInfo userInfo optional, HostPort hostPort, SemicolonParam_List urlParameters optional, AmpersandParam_List headers optional }

- Universal charstrings shall be supported by the codec especially for the Display name in the URI.
- For downlink messages, if a message body is included, the TTCN may set the len field in the ContentLength header to the value -1. In this case the codec shall replace the value by the actual length of the encoded message body (see clause 7.3.4).
- According to the SIP type definitions there are many "charstring" fields being optional in records;
⇒ in UL the decoder shall map missing information by setting the respective field to omit rather than by assigning an empty string (").
- type union Addr_Union
As in 'NameAddr' the field 'displayName' is optional in the first place the two branches of 'Addr_Union' are equivalent when there is no 'displayName'; nevertheless in UL the decoder shall use the branch "nameAddr" if – and only if – the address information is surrounded by "<" and ">" (what is needed at least when there is a display name followed by the address information)
- IPv6 address in URI
When an IPv6 address is used as hostname in a SIP URI it is typically surrounded by "[" and "]" what is matter of the codec: in DL the codec shall add "[" and "]" when needed, in UL the "[" and "]" shall be removed i.e. in the "host" field of the SipUriComponents" hostPort there shall be no "[" or "]" at the beginning or at the end.

7.3.4 Additional requirements for codec implementations (Message Body)

The message body of a SIP message may contain the message of other protocols (SDP, SMS, etc.) and can be represented e.g. by XML. Therefore the type definitions for these protocols can be TTCN-3 as well as XSD definitions.

As in principle the message body of a SIP message may host any XSD definition, SIP and XSD definitions are decoupled:

To avoid import of all potential XSD definitions the XML body of SIP messages is defined as a charstring. This requires a two-stage encoding and decoding: In DL an XML message needs to be encoded in TTCN first before it gets put in the message body of a SIP message, in UL the XML message contained in the message body needs to be explicitly decoded in TTCN. By defining the XML message body as a charstring the SIP definitions are independent from any XSD definitions and a specific XSD definition needs to be known only when it is really used.

In detail the message body for SIP messages is defined as:

type charstring XmlBody;	
type union MessageBody {	
SDP_Message	sdpMessageBody,
XmlBody	xmlBody,
MIME_Message	mimeMessageBody,
charstring	sipfrag,
charstring	textplain,
SimpleMsgSummary	simpleMsgSummary,
octetstring	smsMessage
};	
NOTE:	In contrast to SIP and SDP definitions which are commonly defined by ETSI the definition of the message body is project specific i.e. other IMS test projects at ETSI may use different definitions of the message body.

7.3.5 Additional requirements for codec implementations (SDP Body)

The Session Description Protocol is defined in RFC 4566.

- The 'type' fields (such as 'v' and 'o' are not represented).
- For the defined attributes, the att-field is also not represented (e.g. 'curr' is not represented in SDP_attribute_curr).
- The Messages which are not of interest to a test suite are left undecoded as a charstring and will not be further structured.

7.3.5.1 Differences between BNF - SDP Type Mapping

In normal cases the mapping is straight forward. Below are the exceptions which differ.

- The numerical fields in the origin-field, the time-field and the timezone field have been defined as charstring because they may not fit into a 32-bit signed integer.

BNF Rules of RFC 4566	TTCN 3 Type Mapping
origin = username sess-id sess-version nettype addrtype unicast-address	type record SDP_Origin { charstring username, charstring session_id, charstring session_version, charstring net_type, charstring addr_type, charstring addr }
time-fields = start-time stop-time repeat-fields [zone-adjustments]	type record SDP_time_field { charstring start_time, charstring stop_time }
zone-adjustments = time typed-time	type record SDP_timezone { charstring adjustment_time, SDP_typed_time offset }

- The zone-adjustments field in the time-fields has been included as an additional field in the top-level message definition.

BNF Rules of RFC 4566	TTCN 3 Type Mapping
session-description = proto-version origin-field session-name-field information-field uri-field email-fields phone-fields connection-field bandwidth-fields time-fields key-fields attribute-fields media-descriptions	type record SDP_Message { integer protocol_version, SDP_Origin origin, charstring session_name, charstring information optional, charstring uri optional, SDP_email_list emails optional, SDP_phone_list phone_numbers optional, SDP_connection connection optional, SDP_bandwidth_list bandwidth optional, SDP_time_list times, SDP_timezone_list timezone_adjustments optional, SDP_key key optional, SDP_attribute_list attributes optional, SDP_media_desc_list media_list optional
time-fields = start-time stop-time repeat-fields [zone-adjustments]	type record SDP_time { SDP_time_field time_field, SDP_repeat_list time_repeat optional }

- The mappings for the email-address, phone-number and connection-address fields have been simplified.

BNF Rules of RFC 4566	TTCN 3 Type Mapping
email-address = address-and-comment / dispname-and-address / addrspec	type record SDP_contact { charstring addr_or_phone, charstring disp_name optional }
phone-number = email-safe / email-safe "<" phone ">" / phone	type record SDP_contact { charstring addr_or_phone, charstring disp_name optional }
connection-address = multicast-address / unicast-address	type record SDP_conn_addr { charstring addr, integer ttl optional, integer num_of_addr optional }

7.3.5.2 Defined attributes

The SDP_attribute type is defined as a union of the following attribute types. There is an unknown attribute given to decode undefined attributes with a name and value.

SDP Attribute	TTCN 3 Type Mapping
cat	type record SDP_attribute_cat { charstring attr_value }
charset	type record SDP_attribute_charset { charstring attr_value }
conf	type record SDP_attribute_curr { charstring preconditionType, charstring statusType, charstring direction }
curr	type record SDP_attribute_curr { charstring preconditionType, charstring statusType, charstring direction }
des	type record SDP_attribute_des { charstring preconditionType, }

SDP Attribute	TTCN 3 Type Mapping
	charstring strength, charstring statusType, charstring direction }
fntp	type record SDP_attribute_fntp { charstring attr_value }
framerate	type record SDP_attribute_framerate { charstring attr_value }
inactive	type record SDP_attribute_inactive { }
keywds	type record SDP_attribute_keywds { charstring attr_value }
lang	type record SDP_attribute_lang { charstring attr_value }
orient	type record SDP_attribute_orient { charstring attr_value }
ptime	type record SDP_attribute_ptime { charstring attr_value }
quality	type record SDP_attribute_quality { charstring attr_value }
recvonly	type record SDP_attribute_recvonly { }
rtcp	type record SDP_attribute_rtcp { charstring attr_value }
rtppmap	type record SDP_attribute_rtpmap { charstring attr_value }
sdplang	type record SDP_attribute_sdplang { charstring attr_value }
sendrecv	type record SDP_attribute_sendrecv { }
sendonly	type record SDP_attribute_sendonly { }
Tool	type record SDP_attribute_tool { charstring attr_value }
Type	type record SDP_attribute_type { charstring attr_value }
Unknown	type record SDP_attribute_tool { charstring name, charstring attr_value optional }

7.3.6 Additional requirements for codec implementations (HTTP)

FFS

7.3.7 Additional requirements for codec implementations (XML)

XML data schema is used in IMS conformance testing according to ETSI ES 201 873-9. No further requirements are necessary.

7.4 Requirements for codec implementations (DHCP, DNS)

The DHCP/DNS codec converts TTCN descriptions into/from octet streams as specified in the RFCs. The TTCN type definitions for DHCP/DNS types closely follow the data formats defined in the corresponding RFCs (RFC 1035, RFC 1533, RFC 2131, RFC 3315, RFC 3319 and RFC 3361).

As a special case, when the TTCN length field in a DHCP/DNS record is set to 0 the encoder shall compute the proper length value during encoding.

8 Design consideration

8.1 Bearer Configurations for IMS Testing

8.1.1 Bearer Information for UTRAN

BearerInfo	RANTech = UTRAN_FDD	Description
1	34.108, clause 6.10.2.4.1.56	To be used for IMS Signalling only
2	34.108, clause 6.10.2.4.6.6	Not supported in Rel-5
3	34.108, clause 6.10.2.4.6.7	Not supported in Rel-5
4	25.993, clause 7.1.122	Only supported in Rel-5
5	25.993, clause 7.1.124	Not supported in Rel-5

8.1.2 Bearer Information for GERAN

No specific bearer information has yet been defined. The QoS to be used is therefore dependant on the media applications supported by the UE.

8.1.3 Bearer Information for E-UTRA

BearerInfo	RANTech = E-UTRA_FDD	Description
1	36.508, clause 6.6.1 Reference default EPS bearer context #1	For IMS Signalling and media text
2	36.508, clause 6.6.2 Reference dedicated EPS bearer context #1	For IMS media voice and video
3	36.508, clause 6.6.1 Reference default EPS bearer context #1, except that it is on the Emergency Call PDN	Default bearer for emergency call signalling
4	36.508, clause 6.6.2 Reference dedicated EPS bearer context #1	Dedicated bearer for emergency voice media

8.2 Security

TBD.

8.3 External Function Definitions

The following external functions are required to be implemented by the SS.

TTCN3 External Function	
Name	fx_MD5_Hex
Description	to calculate the MD5 Message-Digest Algorithm according to RFC 1231
Parameters	data octetstring
Return Value	octetstring

Additionally, the following external function is used as defined in TS 36.523-3[30]:

fx_GetSystemTime

8.4 AT commands

No AT commands have yet been defined for IMS operations

Annex A (normative): Abstract Test Suites (ATS)

This annex contains the approved ATSs.

The ATSs have been produced using the Testing and Test Control Notation version 3 (TTCN3) according to ES 201 873 [12].

A.1 Version of specifications

Table A.1 shows the version of the test specifications which the delivered ATSs are referred to.

Table A.1: Versions of the test and Core specifications

Core specifications	3GPP TS 24.229 [11]
Test specifications	3GPP TS 34.229-1 [5]
	3GPP TS 34.229-2 [6]
	3GPP TS 34.123-3 [2]
	3GPP TS 36.523-3 [30]

A.2 IMS-CC ATS

Table A.2: IMS-CC TTCN test cases

Test case	Description
7.1	P-CSCF Discovery via PDP Context
7.2	P-CSCF Discovery via DHCP – IPv4
7.3	P-CSCF Discovery via DHCP – IPv4 (UE Requests P-CSCF discovery via PCO)
7.4	P-CSCF Discovery by DHCP - IPv6
7.5	P-CSCF Discovery by DHCP-IPv6 (UE Requests P-CSCF discovery by PCO)
7.6	P-CSCF Discovery by DHCP – IPv6 (UE does not Request P-CSCF discovery by PCO, SS includes P-CSCF Address(es) in PCO)
8.1	Initial registration
8.2	User Initiated Re-Registration
8.3	Mobile Initiated Deregistration
8.4	Invalid behaviour- 423 Interval too brief
8.10	Initial registration using GIBA
8.12	User initiated re-registration using GIBA
8.13	User initiated de-registration using GIBA
9.1	Invalid Behaviour – MAC Parameter Invalid
9.2	Invalid Behaviour – SQN out of range
10.1	Invalid Behaviour – 503 Service Unavailable
11.1	Network-initiated deregistration
11.2	Network initiated re-authentication
12.2	MO Call – 503 Service Unavailable
12.12	MO MTSI Voice Call Successful with preconditions
12.13	MT MTSI speech call
13.1	SigComp in the Initial registration
15.8	Communication Forwarding on non reply: MO call initiation
15.11	MO Call Hold without announcement
15.12	MT Call Hold without announcement
15.27	Communication Waiting and answering the call
15.28	Communication Waiting and cancelling the call
16.1	Speech AMR, indicate all codec modes
16.2	Speech AMR, indicate selective codec modes
18.1	Mobile Originating SMS
18.2	Mobile Terminating SMS
19.1.2	Emergency call with emergency registration / Success / Location information not available

The ATS is contained in an ASCII file (IMS_CC.ttcn) which accompanies the present document.

A.2.1 Void

A.2.2 Void

A.2.3 Optional IP-CAN TTCN 2++ interface

FFS.

Annex B (normative): Partial IXIT proforma

Notwithstanding the provisions of the copyright related to the text of the present document, The Organizational Partners of 3GPP grant that users of the present document may freely reproduce the partial IXIT proforma in this annex so that it can be used for its intended purposes and may further publish the completed partial IXIT.

B.0 Introduction

This partial IXIT proforma contained in the present document is provided for completion, when the related Abstract Test Suite is to be used against the Implementation Under Test (IUT).

Text in *italics* is comments for guidance for the production of an IXIT, and is not to be included in the actual IXIT.

The completed partial IXIT will normally be used in conjunction with the completed ICS, as it adds precision to the information provided by the ICS.

B.1 Parameter values

Table B.1: PIXIT

Parameter name	Description	Type	Default value	Supported value
px_AssociatedTelUri	TEL URI for the user	charstring	Set as record 3 in EF _{IMPU} as defined in TS 34.229-1[5]	TEL URI
px_AuthAMF	Authentication Management Field (16 bits)	bitstring (16)	'0000000000000000'B	The value shall be different from '1111 1111 1111 1111'B (AMFresynch)
px_AuthK	Authentication Key (128 bits)	bitstring (128)	'0101111001001010101001100100100111011101000000100101110011001111000011000100110100'B	
px_AuthN	Length of Extended value min 31, max 127 (TS 34.108 cl. 8.1.2)	integer	127	
px_AuthRAND	Authentication / Random challenge (128 bits)	bitstring (128)	'01010101...01'B	
px_BearerInfo1	Initial Bearer to be used	integer	1	
px_BearerInfo2	Bearer to be used for Secondary PDP Context	integer	2	
px_CalleeUri	URI of Callee, send in INVITE	charstring	"sip:User-B@3gpp.org"	
px_CalleeContactUri	URI to be used to contact Callee	charstring	"sip:User-B@3gpp.org"	
px_CellId	UTRA or EUTRA cell Id	charstring	"0010100010000001"	See TS 24.229 clause 7.2A.4.3
px_CiphAlgo_Def	Ciphering Algorithm	CiphAlgo	nociph	enumerated type: des_edc3_cbc, aes_cbc or nociph
px_CS_emergency_call_RAT	RAT used for CS Emergency calls	RANTech	UTRA_FDD	enumerated type: GERAN, UTRA_FDD,

Parameter name	Description	Type	Default value	Supported value
				UTRA_TDD, EUTRA_FDD, EUTRA_TDD, C2K_1xRTT
px_DHCPserver_IPAddr	IP address of DHCP server (in v4 or v6 format)	IPAddr	"10.122.11.33"	
px_DNS_DomainName	DNS server fully qualified domain name (FQDN)	charstring	"dnserver.3gpp.org"	
px_DNSServer_IPAddr	IP address of DNS server (in v4 or v6 format)	IPAddr	"10.122.11.33"	
px_FeatureParamValue	Feature Parameter Value	charstring	"+g.3gpp.app_ref="urn%3Aurn-xxx%3A3gpp-service.ims.icசி.mmtel"	
px_HomeDomainName	Home Domain Name. When using anISIM it is set to the same value as EF _{DOMAIN} . When not using ISIM just USIM the home domain name is derived from px_IMSI (preceded by "sip:")	charstring	As defined in TS 34.229-1 [5]	
px_IPSecAlgorithm	Integrity Algorithm	IntAlgo	hmac_md5_96	enumerated type; hmac_md5_96, hmac_sha_1_96
px_P_CSCF_DomainName	P-CSCF fully qualified domain name (FQDN) When an ISIM is used this is set to the same value as the content of EF _{P-CSCF} .	charstring	As defined in TS 34.229-1 [5]	
px_P_CSCF_DomainName_2	Additional P-CSCF FQDN (Full Qualified Domain Name) for special tests	charstring	"pcscf2.3gpp.org"	
px_P_CSCF_DomainName_3	Additional P-CSCF FQDN (Full Qualified Domain Name) for special tests	charstring	"pcscf3.3gpp.org"	
px_P_CSCF_IPAddr	IP address of P-CSCF (in v4 or v6 format)	IPAddr	"10.122.11.33"	
px_P_CSCF_IPAddr_2	Additional P-CSCF IPaddress for special tests (in v4 or v6 format)	IPAddr	"10.122.11.34"	
px_P_CSCF_IPAddr_3	Additional P-CSCF IPaddress for special tests (in v4 or v6 format)	IPAddr	"10.122.11.35"	
px_Pcscf	P-CSCF fully qualified domain name that resolves to the IP address of SS	charstring	"pcscf.3gpp.org"	
px_PeerUE_IPAddr	IP address of peer UE (in v4 or v6 format)	IPAddr	"10.122.11.55"	
px_Port_pc	Protected Client port at the SS (simulated P-CSCF)	integer	5061	
px_Port_ps	Protected Server port at the SS (simulated P-CSCF)	integer	5062	
px_Port_ps_NoSec	Unprotected Server port at the SS (simulated P-CSCF)	integer	5060	
px_Private_UserId	Private User Identity. When using an ISIM this is set to the same value as EF _{IMPI} . When ISIM is not used just USIM the private user identity is derived from px_IMSI.	charstring	As defined in TS 34.229-1 [5]	
px_PublicUserIdentity1	Public User Identity. It is set to the same value as the first record in EF _{IMPU} .	charstring	As defined in TS 34.229-1 [5]"	
px_PublicUserIdentity2	It is set to the same value as the second record in EF _{IMPU} .	Charstring	As defined in TS 34.229-1 [5]	
px_PublicUserIdentity3	It is set to the same value as the third record in EF _{IMPU} .	Charstring	As defined in TS 34.229-1 [5]	
px_RANTech	RAN Technology	RANTech	UTRAN_FDD	enumerated type:

Parameter name	Description	Type	Default value	Supported value
				GERAN, UTRA_FDD, UTRA_TDD, EUTRA_FDD, EUTRA_TDD
px_Scscf	S-CSCF fully qualified domain name that does not resolve to the IP address of SS	charstring	"scscf@3gpp.org"	
px_SS_SipUri	SIP URI with IP Address or FQDN of SS (simulated P-CSCF)	charstring	"sip:pcscf.3gpp.org"	
px_TempGRUUForUE	Temporary GRUU for UE	charstring	"sip:tgruu.7hs==jd7vznga5w7fajsc7-ajd6fabz0f8g5@"	
px_UEInstancelid	UE Instance Identity	charstring	"<urn:uuid:00000000-0000-1000-8000-000A95A0E128>"	
px_UE_IPAddr	IP address assigned to UE (in v4 or v6 format)	IPAddr	"10.122.11.145"	
px_UEwithISIM	true UE has ISIM false UE has USIM only	boolean		
px_UeWithSIM	UE has a SIM inserted	boolean	false	
px_psi_SMSC	The Public Service Identity of the SMSC this is set to the same value as the first record in EF _{PSISMSC} as defined in TS 31.121 [XX].	charstring	As defined in TS 34.229-1 [5]	
px_SMSC_addr	Short message service centre address. When ISIM is used this is the same value as the "TP Service Centre Address" field in EF _{SMSP} .	charstring	As defined in TS 34.229-1 [5]	

B.1.1 SDP parameters for MT call test case

This clause contains parameters to describe one to three media that the SS will propose to the UE in the INVITE Request. This information shall be compatible with the UE's capabilities.

Table B.1.1: SDP parameters for MT call

Parameter name	Description	Type	Default value	Supported value
px_NumberOfMedia	Number of media description	integer	1	1, 2, 3
<i>For each media description, the following parameters shall be supplied:</i>				
px_Media	Media type	charstring	"audio"	audio, video, text, application, message
px_MediaPort	Transport port to which the media stream is sent	integer	49230	Integer within the range 49152 - 65535
px_Proto	Transport protocol	charstring	"RTP/AVP"	UDP, RTP/AVP, RTP/SAVP, TCP, RTP/AVPF, TCP/TLS
px_FmtNumber	Number of Media format description	integer	3	
px_FmtValues	Value of each media format description (in a comma separated list)	charstring	"96, 97, 98"	
px_Bandwidth	Bandwidth value for b=AS (only if RTP/RTCP is used)	integer	75	
px_RS_Bandwidth	Bandwidth value for b=RS (only if RTP/RTCP is used)	integer	75	
px_RR_Bandwidth	Bandwidth value for b=RR (only if RTP/RTCP is used)	integer	75	

Parameter name	Description	Type	Default value	Supported value
px_AttribNumber	Number of attribute ("a=") lines (excluding 'curr' and 'des' lines)	integer	4	
px_AttribValues	Value of each of the attribute lines, excluding 'curr' and 'des' lines (in a comma separated list).	charstring	"rtptime:96 L8/8000, rtptime:97 L16/8000, rtptime:98 L16/11025/2, maxptime:80"	
px_LocalDir	Direction tag for desired local resource	charstring	"sendrcv"	sendrcv, send, rcv
px_RemoteDir	Direction tag for desired remote resource	charstring	"sendrcv"	sendrcv, send, rcv

B.2 MMI Commands

Table B.3 requests additional information needed for the execution of the MMI commands used in the ATS.

Table B.2.1-1: Common MMI Commands

Please De-REGISTER
Please initiate a Call to <callee contact address>
Please initiate an Emergency Call
Please accept MTSI call
Please accept MTSI text
Please set call on hold
Please resume call
Please activate Message Wait Indication
Please trigger UE to send an SMS
Please trigger registration of second IMPU
Please trigger registration of third IMPU"
Please switch off the UE (NOTE 1)
Please switch on the UE (NOTE 1)

NOTE 1: not used for 36.523 test model acc. to clause 5.6.

Table B.2.1-2: MMI Commands for configuration of supplementary services

Pease activate	ORIGINATING IDENTIFICATION PRESENTATION		(UserId <public user id>)
	ORIGINATING IDENTIFICATION RESTRICTION		
	TERMINATING IDENTIFICATION PRESENTATION		
	TERMINATING IDENTIFICATION RESTRICTION		
	COMMUNICATION FORWARDING	UNCONDITIONAL	
		NO ANSWER	
		BUSY	
		NOT REGISTERED	
NOT REACHABLE			
INCOMING COMMUNICATION BARRING	EXCEPT SPECIFIC USER		
	ANONYMOUS USERS		
COMMUNICATION BARRING WHILE ROAMING			
Pease deactivate	ORIGINATING IDENTIFICATION PRESENTATION		(UserId <public user id>)
	ORIGINATING IDENTIFICATION RESTRICTION		
	TERMINATING IDENTIFICATION PRESENTATION		
	TERMINATING IDENTIFICATION RESTRICTION		
	COMMUNICATION FORWARDING	UNCONDITIONAL	
		NO ANSWER	
		BUSY	
		NOT REGISTERED	
		NOT REACHABLE	
	INCOMING COMMUNICATION BARRING	EXCEPT SPECIFIC USER	
		ANONYMOUS USERS	
COMMUNICATION BARRING WHILE ROAMING			

Annex C (informative): Additional information to IXIT

Notwithstanding the provisions of the copyright related to the text of the present document, The Organizational Partners of 3GPP grant that users of the present document may freely reproduce the IXIT proforma in this annex so that it can be used for its intended purposes and may further publish the completed IXIT.

Additional information may be provided when completing the IXIT questions listed in annex A.

C.1 Identification Summary

Table C.1 is completed by the test laboratory. The item "Contract References" is optional.

Table C.1: Identification Summary

IXIT Reference Number	
Test Laboratory Name	
Date of Issue	
Issued to (name of client)	
Contract References	

C.2 Abstract Test Suite Summary

In table C.2 the test laboratory provides the version number of the protocol specification and the version number of ATS which are used in the conformance testing.

Table C.2: ATS Summary

Protocol Specification	3GPP TS 24.229
Version of Protocol Specification	
Test Specification in prose	3GPP TS 34.229-1
Version of TSS & TP Specification	
ATS Specification	3GPP TS 34.229-3
Version of ATS Specification	
Abstract Test Method	Distributed Test Method

C.3 Test Laboratory

C.3.1 Test Laboratory Identification

The test laboratory provides the following information.

Table C.3: Test Laboratory Identification

Name of Test Laboratory	
Postal Address	
Office address	
e-mail address	
Telephone Number	
FAX Number	

C.3.2 Accreditation status of the test service

The test laboratory provides the following information.

Table C.4: Accreditation status of the test service

Accreditation status	
Accreditation Reference	

C.3.3 Manager of Test Laboratory

The test laboratory provides the information about the manager of test laboratory in table C.5.

Table C.5: Manager of Test Laboratory

Name of Manager of Test Laboratory	
e-mail address	
Telephone Number	
FAX Number	
E-mail Address	

C.3.4 Contact person of Test Laboratory

The test laboratory provides the information about the contact person of test laboratory in table C.6.

Table C.6: Contact person of Test Laboratory

Name of Contact of Test Laboratory	
e-mail address	
Telephone Number	
FAX Number	
E-mail Address	

C.3.5 Means of Testing

In table C.7, the test laboratory provides a statement of conformance of the Means Of Testing (MOT) to the reference standardized ATS, and identifies all restrictions for the test execution required by the MOT beyond those stated in the reference standardized ATS.

Table C.7: Means of Testing

Means of Testing

C.3.6 Instructions for Completion

In table C.8, the test laboratory provides any specific instructions necessary for completion and return of the proforma from the client.

Table C.8: Instruction for Completion

Instructions for Completion

C.4 Client

C.4.1 Client Identification

The client provides the identification in table C.9.

Table C.9: Client Identification

Name of Client	
Postal Address	
Office Address	
Telephone Number	
FAX Number	

C.4.2 Client Test Manager

In table C.10 the client provides information about the test manager.

Table C.10: Client Test Manager

Name of Client Test Manager	
Telephone Number	
FAX Number	
E-mail Address	

C.4.3 Client Contact person

In table C.11 the client provides information about the test contact person.

Table C.11: Client Contact person

Name of Client contact person	
Telephone Number	
FAX Number	
E-mail Address	

C.4.4 Test Facilities Required

In table C.12, the client records the particular facilities required for testing, if a range of facilities is provided by the test laboratory.

Table C.12: Test Facilities Required

Test Facilities Required

C.5 System Under Test

C.5.1 SUT Information

The client provides information about the SUT in table C.13.

Table C.13: SUT Information

System Name	
System Version	
SCS Reference	
Machine Configuration	
Operating System Identification	
IUT Identification	
ICS Reference for the IUT	

C.5.2 Limitations of the SUT

In table C.14, the client provides information explaining if any of the abstract tests cannot be executed.

Table C.14: Limitation of the SUT

Limitations of the SUT

C.5.3 Environmental Conditions

In table C.15 the client provides information about any tighter environmental conditions for the correct operation of the SUT.

Table C.15: Environmental Conditions

Environmental Conditions

C.6 Ancillary Protocols

This clause is completed by the client in conjunction with the test laboratory.

In the following tables, the client identifies relevant information concerning each ancillary protocol in the SUT other than the IUT itself. One table for one ancillary protocol.

Based on the MOT the test laboratory should create question proforma for each ancillary protocol in the blank space following each table. The information required is dependent on the MOT and the SUT, and covers all the addressing, parameter values, timer values and facilities (relevant to ENs) as defined by the ICS for the ancillary protocol.

C.6.1 Ancillary Protocols 1

Table C.16: Ancillary Protocol 1

Protocol Name	
Version number	
ICS Reference (optional)	
IXIT Reference (optional)	
PCTR Reference (optional)	

C.6.2 Ancillary Protocols 2

Table C.17: Ancillary Protocol 2

Protocol Name	
Version number	
ICS Reference (optional)	
IXIT Reference (optional)	
PCTR Reference (optional)	

Annex D (informative): PCTR Proforma

Notwithstanding the provisions of the copyright related to the text of the present document, The Organizational Partners of 3GPP grant that users of the present document may freely reproduce the PCTR proforma in this annex so that it can be used for its intended purposes and may further publish the completed PCTR.

PROTOCOL

Conformance Test Report

(PCTR)

Universal Mobile Telecommunication System, UMTS,
User Equipment-Network Access

Layer 3 Signalling Functions

Test Candidate	
Name :	SUT name
Model :	model
H/W version :	hw
S/W version :	sw
Serial No. :	serienr

Client	
Name :	
Street / No. :	
Postal Code / City:	
Country :	

This Test Report shall not be reproduced except in full without the written permission of TEST LAB REFERENCE, and shall not be quoted out of context.

Annex E (informative): TTCN3 style guide for 3GPP IMS ATS

For IMS conformance tests, the style guide of 36.523-3[30], Annex B shall be applied

Annex F (informative): BNF Message Definitions

The BNF definitions required for the ATS are defined in the following RFCs:

3261, 3262, 3265, 3311, 3313, 3323, 3325, 3326, 3327, 3329, 3428, 3455, 3515, 3608, 3840, 3841, 3891, 3892, 3903, 3911, 4028.

Annex G (Normative): SIP Type Definitions and XSD References

The XSD references listed in this Annex are imported in the Test Suite.

XML Schema	RFC	Name space	Modifications
reginfo	RFC 3680	urn:ietf:params:xml:ns:reginfo	"http://www.w3.org/2001/03/xml.xsd" to be replaced by 'xml.xsd'
conference-info	RFC 4575	urn:ietf:params:xml:ns:conference-info	
gruuinfo	RFC 5628	urn:ietf:params:xml:ns:gruuinfo	

Additionally the Test Suite imports the following modules of ETSI's LibSip (the modules are store in ETSI's SIP library repository; FFS):

Module	Revision
LibSip_SDPTypes	FFS
LibSip_SimpleMsgSummaryTypes	FFS
LibSip_SIPTypesAndValues	FFS

Annex H (informative): Change history

Meeting	TSG doc	CR	Rev	Subject	Cat	Old vers	New vers	WG doc
RP-31	RP-060054	-	-	Update to version 1.0.0 and present to RAN#31 for information	-	-	1.0.0	R5-060513
RP-34	RP-060664	-	-	Present version 1.3.0 to RAN#34 for information	-	-	1.3.0	R5-063500
RP-35	RP-070010	-	-	Presented as version 2.0.0 for approval to go under revision control	-	-	2.0.0	R5-070456
-	-	-	-	Upgraded to version 5.0.0 by the 3GPP support	-	-	5.0.0	-
RP-36	RP-070352	0001	-	Addition of IMS-CC test case 8.6 to IMS_CC ATS V1.3.0	F	5.0.0	5.1.0	R5s070101
RP-36	RP-070353	0002	-	CR to 34.229-3: Add new verified and e-mail agreed TTCN test cases in the TC lists in 34.229-3 (prose), Annex A	F	5.0.0	5.1.0	-
RP-37	RP-070594	0003	-	Extension to TTCN ASP DeactivatePDPCContextReq	F	5.1.0	5.2.0	R5-072509
RP-37	RP-070594	0004	-	IMS CC / PIXIT parameter px_CellId	F	5.1.0	5.2.0	R5-072546
RP-38	RP-070870	0007		Addition of IMS-CC test case 8.5 to IMS_CC ATS V5.1.0	B	5.2.0	5.3.0	R5s070489
RP-38	RP-070870	0008		Addition of IMS-CC test case 8.7 to IMS_CC ATS V5.3.0	B	5.2.0	5.3.0	R5s070259
RP-38	RP-070870	0009		Addition of IMS-CC test case 9.1 to IMS_CC ATS V5.3.0	B	5.2.0	5.3.0	R5s070261
RP-38	RP-070889	0010		CR to 34.229-3: Add new verified and e-mail agreed TTCN test cases in the TC lists in 34.229-3 (prose), Annex A	F	5.2.0	5.3.0	-
RP-38	RP-070869	0006		Production of 34.229-3 pointer version in Rel-5 pointing to Rel-6 version	F	5.2.0	5.3.0	R5-073439
RP-38	RP-070869	0005		Addition of an MMI command	F	5.2.0	6.0.0	R5-073046
RP-39	RP-080098	0011		Update of MMI command strings	F	6.0.0	6.1.0	R5-080041
RP-39	RP-080089	0012		CR to 34.229-3: Add new verified and e-mail agreed TTCN test cases in the TC lists in 34.229-3 (prose), Annex A	F	6.0.0	6.1.0	-
RP-39	RP-080094	0013		Addition of IMS-CC test case 7.2 to IMS_CC ATS V5.3.0	B	6.0.0	6.1.0	R5s070535
RP-39	RP-080094	0014		Addition of IMS-CC test case 10.1 to IMS_CC ATS V5.1.0	B	6.0.0	6.1.0	R5s070549
RP-39	RP-080094	0015		Addition of IMS-CC test case 8.3 to IMS_CC ATS V5.1.0	B	6.0.0	6.1.0	R5s070545
RP-39	RP-080094	0016		Addition of IMS-CC test case 8.2 to IMS_CC ATS V5.1.0	B	6.0.0	6.1.0	R5s070543
RP-39	RP-080094	0017		Addition of IMS-CC test case 7.6 to IMS_CC ATS V5.1.0	B	6.0.0	6.1.0	R5s070539
RP-39	RP-080094	0018		Addition of IMS-CC test case 7.4 to IMS_CC ATS V5.1.0	B	6.0.0	6.1.0	R5s070537
RP-39	RP-080094	0019		Addition of IMS-CC test case 11.1 to IMS_CC ATS V5.1.0	B	6.0.0	6.1.0	R5s070551
RP-39	RP-080094	0020		Addition of IMS-CC test case 14.1 to IMS_CC ATS V5.1.0	B	6.0.0	6.1.0	R5s070555
RP-39	RP-080094	0021		Addition of IMS-CC test case 13.1 to IMS_CC ATS V5.1.0	B	6.0.0	6.1.0	R5s070553
RP-39	RP-080094	0022		Addition of IMS-CC test case 8.4 to IMS_CC ATS V5.1.0	B	6.0.0	6.1.0	R5s070547
RP-39	RP-080094	0023		Addition of IMS-CC test case 8.1 to IMS_CC ATS V5.1.0	B	6.0.0	6.1.0	R5s070541
RP-39	RP-080094	0024		Addition of IMS-CC test case 7.1 to IMS_CC ATS V5.1.0	B	6.0.0	6.1.0	R5s070491
RP-39	RP-080094	0025		Common corrections to IMS-CC test cases	F	6.0.0	6.1.0	R5s070534
RP-40	RP-080369	0027		Correction to regular expressions in IMS	F	6.1.0	7.0.0	R5s080036
RP-40	RP-080369	0028		IMS ATS / handling of P-Access-Network-Info header over non secure ports	F	6.1.0	7.0.0	R5s080063
RP-40	RP-080369	0029		IMS ATS / test case 9.1 / handling of authorization header in Register messages	F	6.1.0	7.0.0	R5s080085
RP-40	RP-080376	0030		Extend test model supporting XCAP test	F	6.1.0	7.0.0	R5-081036
RP-41	RP-080654	0031		CR to 34.229-3: Add new verified and e-mail agreed TTCN test cases in the TC lists in 34.229-3 (prose), Annex A	F	7.0.0	7.1.0	-
RP-41	RP-080615	0032		Addition of IMS-CC test case 9.2 to IMS_CC ATS v.7.0.0	F	7.0.0	7.1.0	R5s080115
RP-41	RP-080615	0033		Addition of IMS-CC test case 7.3 to IMS_CC ATS	F	7.0.0	7.1.0	R5s080114

Meeting	TSG doc	CR	Rev	Subject	Cat	Old vers	New vers	WG doc
				v.7.0.0				
RP-41	RP-080615	0034		Implementation of IPCanCtl code as a parallel test component	F	7.0.0	7.1.0	R5s080138
RP-41	RP-080615	0035		Addition of IMS-CC test case 8.9 to IMS_CC ATS v.6.2.0	F	7.0.0	7.1.0	R5s080145
RP-41	RP-080615	0036		Addition of IMS-CC test case 8.8 to IMS_CC ATS v.6.2.0	F	7.0.0	7.1.0	R5s080143
RP-41	RP-080615	0037		Addition of IMS-CC test case 7.5 to IMS_CC ATS	F	7.0.0	7.1.0	R5s080151
RP-41	RP-080740	0038		Update of TS 34.229-3 from Rel-6 to Rel-7	F	7.1.0	7.2.0	R5-083065
RP-42	RP-080959	0039		Correction of HW Type and HW Length fields in DHCP response messages	F	7.1.0	7.2.0	R5s080171
RP-42	RP-080959	0040		Minor correction of Route header template in the initial Register message	F	7.1.0	7.2.0	R5s080168
RP-43	RP-090210	0041		Update of TS 34.229-3 from Rel-7 to Rel-8	F	7.2.0	8.0.0	R5-090765
RP-43	RP-090210	0042		IMS CC ATS / Improvement: Stopping test case execution once a PTC fails	F	8.0.0	8.1.0	R5s090019
RP-43	RP-090210	0043		IMS CC ATS / Handling of non-default port number in the Contact Header	F	8.0.0	8.1.0	R5s090018
RP-43	RP-090210	0044		IMS CC ATS / Handling of Contact Header	F	8.0.0	8.1.0	R5s090005
RP-43	RP-090210	0045		IMS CC / Minor corrections on test 11.2 (re-authentication)	F	8.0.0	8.1.0	R5s090004
RP-43	RP-090210	0046		IMS CC / Addition of test case 11.2 to the IMS ATS	F	8.0.0	8.1.0	R5s080313
RP-43	RP-090210	0047		IMS CC test model / Addition of new ASP to reconfigure IP Layer	F	8.0.0	8.1.0	R5-090032
RP-43	RP-090210	0048		Removal of an unused pixon and other routine updates	F	8.0.0	8.1.0	R5-090056
RP-46	RP-091156	0049	-	CR to 34.229-3 (prose) update to v820	F	8.1.0	8.2.0	-
RP-47	RP-100146	0050	-	CR to 34.229-3 (prose) update to v830	F	8.2.0	8.3.0	-
RP-47	RP-100155	0051	-	Correction of IMS test model for XCAP-based SS test	F	8.2.0	8.3.0	R5-100087
RP-47	RP-100140	0052	-	Add bearer information for E-UTRA	F	8.2.0	8.3.0	R5-100414
RP-48	RP-100514	0053	-	CR to 34.229-3 (prose) update to v840	F	8.3.0	8.4.0	-
RP-48	RP-100511	0054	-	Update IMS test model	F	8.3.0	8.4.0	R5-103382
RP-50	RP-101146	0055	-	Routine maintenance of TS 34.229-3	F	8.4.0	8.5.0	R5-106088
RP-50	RP-101150	0056	-	CR to 34.229-3 update to v850	F	8.4.0	8.5.0	-
RP-51	RP-110165	0057	-	Mapping of some PIXIT parameters to ISIM EFs – 3 IMPU	F	8.5.0	8.6.0	R5-110694
RP-51	RP-110169	0058	-	CR to 34.229-3 (prose) update to v860	F	8.5.0	8.6.0	-
RP-52	RP-110651	0059	-	Removal of technical content in 34.229-3 v8.6.0 and substitution with pointer to the next Release	F	8.6.0	8.7.0	R5-112246
RP-52	RP-110651	0060	-	Routine maintenance	F	8.6.0	9.0.0	R5-112648
RP-52	RP-110655	0061	-	CR to 34.229-3 (prose) update to v870	F	8.6.0	9.0.0	-
RP-53	RP-111160	0062	-	CR to 34.229-3 (prose) update to v910	F	9.0.0	9.1.0	-
RP-54	RP-111584	0063	-	Routine maintenance and updates for IMS ASP	F	9.1.0	9.2.0	R5-115670
RP-55	RP-120187	0064	-	CR to 34.229-3 (prose) update to v930	F	9.2.0	9.3.0	-
RP-56	RP-120649	0065	-	Routine maintenance and updates	F	9.3.0	9.4.0	R5-121090
RP-56	RP-120802	0066	-	Correction to IMS CC test cases / IPv6 address handling	F	9.3.0	9.4.0	R5s120108
RP-57	RP-121103	0067	-	34229-3: Routine maintenance and updates	F	9.4.0	9.5.0	R5-123085
RP-57	RP-121221	0068	-	TTCN IMS correction	F	9.4.0	9.5.0	R5s120530
RP-57	RP-121221	0069	-	Addition of GCF WI-031 IMS test case 8.10	F	9.4.0	9.5.0	R5s120537
RP-57	RP-121221	0070	-	Addition of GCF WI-031 IMS test case 8.12	F	9.4.0	9.5.0	R5s120539
RP-57	RP-121221	0071	-	Addition of GCF WI-031 IMS test case 8.13	F	9.4.0	9.5.0	R5s120541
RP-57	RP-121221	0072	-	Addition of GCF WI-128 IMS test case 18.1	F	9.4.0	9.5.0	R5s120543
RP-57	RP-121221	0073	-	Addition of GCF WI-128 IMS test case 18.2	F	9.4.0	9.5.0	R5s120545
RP-57	RP-121221	0074	-	Addition of GCF WI-103 IMS test case 16.1	F	9.4.0	9.5.0	R5s120547
RP-57	RP-121221	0075	-	Addition of GCF WI-103 IMS test case 16.2	F	9.4.0	9.5.0	R5s120549
RP-57	RP-121106	0076	-	CR to 34.229-3: Add new verified and e-mail agreed TTCN test cases in the TC lists in 34.229-3 (prose), Annex A	F	9.4.0	9.5.0	-
RP-58	RP-121664	0077	-	34229-3: Routine maintenance and updates	F	9.5.0	9.6.0	R5-125120
RP-58	RP-121669	0078	-	Addition of GCF WI-103 IMS test case 12.12	B	9.5.0	9.6.0	R5s120605
RP-58	RP-121669	0079	-	Addition of GCF WI-103 IMS test case 12.13	B	9.5.0	9.6.0	R5s120607
RP-58	RP-121669	0080	-	Addition of GCF WI-103 IMS test case 15.11	B	9.5.0	9.6.0	R5s120609
RP-58	RP-121669	0081	-	IMS TTCN correction	F	9.5.0	9.6.0	R5s120729
RP-58	RP-121669	0082	-	Addition of GCF WI-103 IMS test case 15.8	B	9.5.0	9.6.0	R5s120730
RP-58	RP-121669	0083	-	Addition of GCF WI-103 IMS test case 15.12	B	9.5.0	9.6.0	R5s120732
RP-58	RP-121669	0084	-	Addition of GCF WI-103 IMS test case 15.27	B	9.5.0	9.6.0	R5s120733
RP-58	RP-121669	0085	-	Addition of GCF WI-103 IMS test case 15.28	B	9.5.0	9.6.0	R5s120736
RP-58	RP-121668	0086	-	CR to 34.229-3: Add new verified and e-mail agreed TTCN test cases in the TC lists in 34.229-3 (prose), Annex A	F	9.5.0	9.6.0	-
RP-59	RP-130145	0087	-	34229-3: Routine maintenance and updates	F	9.6.0	9.7.0	R5-130198
RP-59	RP-130150	0088	-	Re-verification of IMS Registration test case 8.10 over	F	9.6.0	9.7.0	R5s120858

Meeting	TSG doc	CR	Rev	Subject	Cat	Old vers	New vers	WG doc
				LTE with 36.523-3 test model				
RP-59	RP-130150	0089	-	Corrections for IMS test cases with 34.229-3 test model	F	9.6.0	9.7.0	R5s120907
RP-59	RP-130150	0090	-	Re-verification of IMS Registration test case 8.4 over LTE with new 34.229-3 test model	F	9.6.0	9.7.0	R5s120945
RP-59	RP-130150	0091	-	Re-verification of IMS Authentication test case 9.1 over LTE with the new 34.229-3 test model	F	9.6.0	9.7.0	R5s120947
RP-59	RP-130150	0092	-	Corrections to IMS_36523_IWD_12wk48 test suite	F	9.6.0	9.7.0	R5s130011
RP-59	RP-130150	0093	-	Corrections for IMS TC 8.1 regarding IPv6 privacy	F	9.6.0	9.7.0	R5s130049
RP-59	RP-130149	0094	-	CR to 34.229-3 (prose) update to v970	F	9.6.0	9.7.0	-
RP-60	RP-130611	0095	-	34229-3: Routine maintenance and updates	F	9.7.0	9.8.0	R5-131140
RP-60	RP-130617	0096	-	Corrections to feature parameter in MT call invitation	F	9.7.0	9.8.0	R5s130109
RP-60	RP-130617	0097	-	Re-verification of IMS Registration (IPSec) test case 8.1 over LTE with 36.523-3 test model	F	9.7.0	9.8.0	R5s130133
RP-60	RP-130617	0098	-	Re-verification of IMS test case 8.3 over LTE with 36.523-3 test model	F	9.7.0	9.8.0	R5s130181
RP-60	RP-130617	0099	-	Re-verification of IMS SMS test case 18.2 over LTE with 36.523-3 test model	F	9.7.0	9.8.0	R5s130183
RP-60	RP-130617	0100	-	Corrections for IMS TC 8.1	F	9.7.0	9.8.0	R5s130187
RP-60	RP-130617	0101	-	Re-verification of IMS Registration test case 8.2 over LTE with 34.229-3 test model	F	9.7.0	9.8.0	R5s130233
RP-60	RP-130617	0102	-	Re-verification of IMS SMS test case 18.1 over LTE with 34.229-3 test model	F	9.7.0	9.8.0	R5s130235
RP-60	RP-130617	0103	-	Correction to SIP template cr_FromWithTag	F	9.7.0	9.8.0	R5s130256
RP-60	RP-130617	0104	-	Re-verification of IMS Authentication test case 9.2 over LTE with 34.229-3 test model	F	9.7.0	9.8.0	R5s130264
RP-60	RP-130617	0105	-	Re-verification of IMS Notification test case 11.2 over LTE with 34.229-3 test model	F	9.7.0	9.8.0	R5s130266
RP-60	RP-130617	0106	-	Corrections for IMS Registration TC 8.3 over LTE with 34.229-3 test model	F	9.7.0	9.8.0	R5s130274
RP-60	RP-130617	0107	-	Re-verification of IMS Subscription test case 10.1 over LTE with 34.229-3 test model	F	9.7.0	9.8.0	R5s130294
RP-60	RP-130617	0108	-	Re-verification of IMS Registration test case 11.1 over LTE with 34.229-3 test model	F	9.7.0	9.8.0	R5s130296
RP-60	RP-130617	0109	-	Re-verification of IMS Call Control test case 12.12 over LTE with 36.523-3 test model	F	9.7.0	9.8.0	R5s130333
RP-61	RP-131107	0111	-	Correction to EPS ATTACH procedure to enable IMS Registration via NAS signalling	F	9.8.0	9.9.0	R5s130383
RP-61	RP-131107	0112	-	Correction to IMS test cases 8.1, 8.2, 8.3 and 8.4	F	9.8.0	9.9.0	R5s130454
RP-61	RP-131107	0113	-	Correction to encoding rules to be used for Reginfo_Type	F	9.8.0	9.9.0	R5s130474
RP-61	RP-131107	0114	-	Corrections for IMS call control test case 12.12	F	9.8.0	9.9.0	R5s130497
RP-61	RP-131107	0115	-	Addition of GCF WI-154/ee1 IMS Emergency Call over EPS test case 19.1.2 (... using TS 36.523-3 test model)	B	9.8.0	9.9.0	R5s130508
RP-61	RP-131107	0116	-	Re-verification for IMS TC 12.13 over LTE with 34.229-3 test model	F	9.8.0	9.9.0	R5s130510
RP-61	RP-131107	0117	-	Corrections to GCF WI-128 SMS over IMS Testcase 18.1	F	9.8.0	9.9.0	R5s130514
RP-61	RP-131107	0118	-	Correction of IMS test case 9.2 over LTE with 34.229-3 test model	F	9.8.0	9.9.0	R5s130573

Meeting	TSG doc	CR	Rev	Subject	Cat	Old vers	New vers	WG doc
RP-61	RP-131107	0119	-	Verification for IMS test case 12.2 over LTE with 34.229-1 test model	B	9.8.0	9.9.0	R5s130580
RP-61	RP-131107	0120	-	Correction of IMS test case 12.12 over LTE with 34.229-3 test model	F	9.8.0	9.9.0	R5s130586
RP-61	RP-131106	0121	-	CR to 34.229-3: Add new verified and e-mail agreed TTCN test cases in the TC lists in 34.229-3 (prose), Annex A	F	9.8.0	9.9.0	RP-131106

History

Document history		
V9.0.0	July 2011	Publication
V9.1.1	December 2011	Publication
V9.2.0	January 2012	Publication
V9.3.0	March 2012	Publication
V9.4.0	July 2012	Publication
V9.5.0	October 2012	Publication
V9.6.0	January 2013	Publication
V9.7.0	April 2013	Publication
V9.8.0	July 2013	Publication
V9.9.0	October 2013	Publication