



**Universal Mobile Telecommunications System (UMTS);
LTE;
Internet Protocol (IP) multimedia call control protocol based on
Session Initiation Protocol (SIP)
and Session Description Protocol (SDP);
User Equipment (UE) conformance specification;
Part 3: Abstract test suite (ATS)
(3GPP TS 34.229-3 version 10.3.0 Release 10)**



Reference

RTS/TSGR-0534229-3va30

Keywords

LTE,UMTS

ETSI

650 Route des Lucioles
F-06921 Sophia Antipolis Cedex - FRANCE

Tel.: +33 4 92 94 42 00 Fax: +33 4 93 65 47 16

Siret N° 348 623 562 00017 - NAF 742 C
Association à but non lucratif enregistrée à la
Sous-Préfecture de Grasse (06) N° 7803/88

Important notice

The present document can be downloaded from:

<http://www.etsi.org>

The present document may be made available in electronic versions and/or in print. The content of any electronic and/or print versions of the present document shall not be modified without the prior written authorization of ETSI. In case of any existing or perceived difference in contents between such versions and/or in print, the only prevailing document is the print of the Portable Document Format (PDF) version kept on a specific network drive within ETSI Secretariat.

Users of the present document should be aware that the document may be subject to revision or change of status. Information on the current status of this and other ETSI documents is available at

<http://portal.etsi.org/tb/status/status.asp>

If you find errors in the present document, please send your comment to one of the following services:

http://portal.etsi.org/chaicor/ETSI_support.asp

Copyright Notification

No part may be reproduced or utilized in any form or by any means, electronic or mechanical, including photocopying and microfilm except as authorized by written permission of ETSI.

The content of the PDF version shall not be modified without the written authorization of ETSI.
The copyright and the foregoing restriction extend to reproduction in all media.

© European Telecommunications Standards Institute 2014.

All rights reserved.

DECT™, **PLUGTESTS™**, **UMTS™** and the ETSI logo are Trade Marks of ETSI registered for the benefit of its Members.
3GPP™ and **LTE™** are Trade Marks of ETSI registered for the benefit of its Members and of the 3GPP Organizational Partners.
GSM® and the GSM logo are Trade Marks registered and owned by the GSM Association.

Intellectual Property Rights

IPRs essential or potentially essential to the present document may have been declared to ETSI. The information pertaining to these essential IPRs, if any, is publicly available for **ETSI members and non-members**, and can be found in ETSI SR 000 314: *"Intellectual Property Rights (IPRs); Essential, or potentially Essential, IPRs notified to ETSI in respect of ETSI standards"*, which is available from the ETSI Secretariat. Latest updates are available on the ETSI Web server (<http://ipr.etsi.org>).

Pursuant to the ETSI IPR Policy, no investigation, including IPR searches, has been carried out by ETSI. No guarantee can be given as to the existence of other IPRs not referenced in ETSI SR 000 314 (or the updates on the ETSI Web server) which are, or may be, or may become, essential to the present document.

Foreword

This Technical Specification (TS) has been produced by ETSI 3rd Generation Partnership Project (3GPP).

The present document may refer to technical specifications or reports using their 3GPP identities, UMTS identities or GSM identities. These should be interpreted as being references to the corresponding ETSI deliverables.

The cross reference between GSM, UMTS, 3GPP and ETSI identities can be found under <http://webapp.etsi.org/key/queryform.asp>.

Modal verbs terminology

In the present document "**shall**", "**shall not**", "**should**", "**should not**", "**may**", "**may not**", "**need**", "**need not**", "**will**", "**will not**", "**can**" and "**cannot**" are to be interpreted as described in clause 3.2 of the [ETSI Drafting Rules](#) (Verbal forms for the expression of provisions).

"**must**" and "**must not**" are **NOT** allowed in ETSI deliverables except when used in direct citation.

Contents

Intellectual Property Rights	2
Foreword.....	2
Modal verbs terminology.....	2
Foreword.....	5
Introduction	5
1 Scope	6
2 References	6
3 Definitions and abbreviations.....	8
3.1 Definitions	8
3.2 Abbreviations	9
4 Requirements on the TTCN development.....	9
5 Test method and test model.....	9
5.1 Test method	9
5.2 IMS CC test model	9
5.3 Upper Tester (UT).....	11
5.4 TTCN-3	11
5.5 Support of XCAP	11
5.5.1 XCAP Server	12
5.5.2 HTTP Signalling	13
5.6 Void.....	14
6 ASP definitions	14
6.1 Void.....	14
6.2 Void.....	14
6.3 Void.....	14
6.4 HTTP Layer ASP definitions	14
6.5 XCAP server ASP definitions	17
7 Codec definitions for IP User Data	17
7.1 Introduction	17
7.2 General Aspects.....	17
7.3 Requirements on abstract message syntax for IMS (SIP, SDP)	18
7.3.1 Type definition - Syntax / Semantic aspects	18
7.3.2 Deviations of the type definition semantic	18
7.3.3 Additional requirements for codec implementations (SIP/IMS Message)	19
7.3.3.1 Differences between BNF - TTCN-3 Type Mapping.....	19
7.3.3.2 URL Encoding	23
7.3.4 Additional requirements for codec implementations (Message Body)	23
7.3.5 Additional requirements for codec implementations (SDP Body).....	23
7.3.5.1 Differences between BNF - SDP Type Mapping	24
7.3.5.2 Defined attributes.....	25
7.3.6 Additional requirements for codec implementations (HTTP).....	26
7.3.7 Additional requirements for codec implementations (XML).....	26
7.4 Requirements for codec implementations (DHCP, DNS)	26
8 Design consideration	27
8.1 Void.....	27
8.2 Void.....	27
8.3 Void.....	27
8.4 AT commands	27
8.5 Timer Tolerances.....	27
Annex A (normative): Abstract Test Suites (ATS).....	28

A.1	Version of specifications	28
A.2	IMS-CC ATS.....	28
A.2.1	Void.....	29
A.2.2	Void.....	29
A.2.3	Void.....	29
Annex B (normative):	Partial IXIT proforma.....	29
B.0	Introduction	30
B.1	Parameter values	30
B.1.1	PIXITs.....	30
B.2	MMI Commands	31
Annex C:	Void	32
Annex D:	Void	33
Annex E (informative):	TTCN3 style guide for 3GPP IMS ATS.....	34
Annex F (informative):	BNF Message Definitions	35
Annex G (Normative):	SIP Type Definitions and XSD References.....	36
Annex H (informative):	TTCN-3 Definitions of Common Interfaces	37
H.1	IMS_PTC_CoordMsg	37
H.2	IMS_ASP_TypeDefs.....	40
H.3	43	
H.4	References to TTCN-3	43
Annex I (informative):	Change history	44
History		50

Foreword

This Technical Specification has been produced by the 3rd Generation Partnership Project (3GPP).

The contents of the present document are subject to continuing work within the TSG and may change following formal TSG approval. Should the TSG modify the contents of the present document, it will be re-released by the TSG with an identifying change of release date and an increase in version number as follows:

Version x.y.z

where:

- x the first digit:
 - 1 presented to TSG for information;
 - 2 presented to TSG for approval;
 - 3 or greater indicates TSG approved document under change control.
- y the second digit is incremented for all changes of substance, i.e. technical enhancements, corrections, updates, etc.
- z the third digit is incremented when editorial only changes have been incorporated in the document.

Introduction

The present document is 3rd part of a multi-part conformance test specification for UE and is *valid for 3GPP Release 5 and above*. The specification contains a TTCN design frame work and the detailed test specifications in TTCN for the UE conformance at the Gm reference point.

3GPP TS 34.229-1 [5] contains a conformance test description in prose.

3GPP TS 34.229-2 [6] contains a pro-forma for the UE Implementation Conformance Statement (ICS).

3GPP TS 34.229-3 the present document.

1 Scope

The present document specifies the protocol conformance testing in TTCN for the 3GPP User Equipment (UE) at the Gm interface.

The present document is the 3rd part of a multi-part test specification, 3GPP TS 34.229. The following TTCN test specification and design considerations can be found in the present document:

- the overall test suite structure;
- the testing architecture;
- the test methods and PCO definitions;
- the test configurations;
- the design principles, assumptions, and used interfaces to the TTCN tester (System Simulator);
- TTCN styles and conventions;
- the partial PIXIT proforma;
- the TTCN files for the mentioned protocols tests.

The Abstract Test Suites designed in the document are based on the test cases specified in prose (3GPP TS 34.229-1 [5]).

The present document is valid for UE implemented according 3GPP Releases starting from Release 5 up to the Release indicated on the cover page of the present document.

2 References

The following documents contain provisions which, through reference in this text, constitute provisions of the present document.

- References are either specific (identified by date of publication, edition number, version number, etc.) or non-specific.
- For a specific reference, subsequent revisions do not apply.
- For a non-specific reference, the latest version applies. In the case of a reference to a 3GPP document (including a GSM document), a non-specific reference implicitly refers to the latest version of that document in the same Release as the present document.
 - For a Release 5 UE, references to 3GPP documents are to version 5.x.y, when available.
 - For a Release 6 UE, references to 3GPP documents are to version 6.x.y, when available.

- [1] 3GPP TR 21.905: "Vocabulary for 3GPP Specifications".
- [2] 3GPP TS 34.123-1: "User Equipment (UE) conformance specification; Part 1: Protocol conformance specification".
- [3] 3GPP TS 34.123-2: "User Equipment (UE) conformance specification; Part 2: Implementation Conformance Statement (ICS) proforma specification".
- [4] 3GPP TS 34.123-3: "User Equipment (UE) conformance specification; Part 3: Abstract Test Suites (ATS)".
- [5] 3GPP TS 34.229-1: "Internet Protocol (IP) multimedia call control protocol based on Session Initiation Protocol (SIP) and Session Description Protocol (SDP); User Equipment (UE) conformance specification; Part 1: Protocol conformance specification".

- [6] 3GPP TS 34.229-2: "Internet Protocol (IP) multimedia call control protocol based on Session Initiation Protocol (SIP) and Session Description Protocol (SDP); User Equipment (UE) conformance specification; Part 2: Implementation Conformance Statement (ICS) specification".
- [7] 3GPP TS 34.108: "Common test environments for User Equipment (UE) conformance testing".
- [8] ISO/IEC 9646-1: "Information technology - Open systems interconnection - Conformance testing methodology and framework - Part 1: General concepts".
- [9] ISO/IEC 9646-7: "Information technology - Open systems interconnection - Conformance testing methodology and framework - Part 7: Implementation Conformance Statements".
- [10] ETSI ETS 300 406 (1995): "Methods for testing and Specification (MTS); Protocol and profile conformance testing specifications; Standardization methodology".
- [11] 3GPP TS 24.229: "IP Multimedia Call Control Protocol based on Session Initiation Protocol (SIP) and Session Description Protocol (SDP); Stage 3".
- [12] ETSI ES 201 873: "Methods for Testing and Specification (MTS); The Testing and Test Control Notation version 3".
- [13] IETF RFC 3320: "Signalling Compression (SigComp)".
- [14] IETF RFC 3485: "The Session Initiation Protocol (SIP) and Session Description Protocol (SDP) Static Dictionary for Signalling Compression (SigComp)".
- [15] IETF RFC 3486: "Compressing the Session Initiation Protocol (SIP)".
- [16] IETF RFC 3261: "SIP: Session Initiation Protocol".
- [17] IETF RFC 4566: "SDP: Session Description Protocol".
- [18] IETF RFC 1035: "Domain names - implementation and specification".
- [19] IETF RFC 1533: "DHCP Options and BOOTP Vendor Extensions".
- [20] IETF RFC 2131: "Dynamic Host Configuration Protocol".
- [21] IETF RFC 3315: "Dynamic Host Configuration Protocol for IPv6 (DHCPv6)".
- [22] IETF RFC 3319: "Dynamic Host Configuration Protocol (DHCPv6) Options for Session Initiation Protocol (SIP) Servers".
- [23] IETF RFC 3361: "Dynamic Host Configuration Protocol (DHCP-for-IPv4) Option for Session Initiation Protocol (SIP) Servers".
- [24] IETF RFC 3680: "A Session Initiation Protocol (SIP) Event Package for Registrations".
- [25] 3GPP TS 24.173: "IMS multimedia telephony communication service and supplementary services; Stage 3".
- [26] IETF RFC 4825: "The Extensible Markup Language (XML) Configuration Access Protocol (XCAP)".
- [27] IETF RFC 2616: "Hypertext Transfer Protocol – HTTP/1.1".
- [28] 3GPP TS 36.523-1: "Evolved Universal Terrestrial Radio Access (E-UTRA) and Evolved Packet Core (EPC); User Equipment (UE) conformance specification; Part 1: Protocol conformance specification".
- [29] 3GPP TS 36.523-2: "Evolved Universal Terrestrial Radio Access (E-UTRA) and Evolved Packet Core (EPC); User Equipment (UE) conformance specification; Part 2: Implementation Conformance Statement (ICS) proforma specification".
- [30] 3GPP TS 36.523-3: "Evolved Universal Terrestrial Radio Access (E-UTRA) and Evolved Packet Core (EPC); User Equipment (UE) conformance specification; Part 3: Test suites".

- [31] 3GPP TS 36.508: "Evolved Universal Terrestrial Radio Access (E-UTRA) and Evolved Packet Core (EPC); Common test environments for User Equipment (UE) conformance testing".
- [32] 3GPP TS 24.173: "IMS Multimedia telephony communication service and supplementary services; Stage 3".
- [33] 3GPP TS 24.109: "Bootstrapping interface (Ub) and network application function interface (Ua); Protocol details".
- [34] 3GPP TS 33.220: "Generic Authentication Architecture (GAA); Generic Bootstrapping Architecture".
- [35] 3GPP TS 33.222: "Generic Authentication Architecture (GAA); Access to network application functions using Hypertext Transfer Protocol over Transport Layer Security (HTTPS)".
- [36] 3GPP TS 24.623: "Extensible Markup Language (XML) Configuration Access Protocol (XCAP) over the Ut interface for Manipulating Supplementary Services".
- [37] RFC 2617: "HTTP Authentication: Basic and Digest Access Authentication".
- [38] RFC 3966: "The tel URI for Telephone Numbers".
- [39] RFC 2141: 'URN Syntax'.
- [40] 3GPP TS 24.604: "Communication Diversion (CDIV) using IP Multimedia (IM) Core Network (CN) subsystem; Protocol specification".
- [41] 3GPP TS 24.607: "Originating Identification Presentation (OIP) and Originating Identification Restriction (OIR) using IP Multimedia (IM) Core Network (CN) subsystem; Protocol specification".
- [42] 3GPP TS 24.608: "Terminating Identification Presentation (TIP) and Terminating Identification Restriction (TIR) using IP Multimedia (IM) Core Network (CN) subsystem; Protocol specification".
- [43] 3GPP TS 24.611: 'Anonymous Communication Rejection (ACR) and Communication Barring (CB) using IP Multimedia (IM) Core Network (CN) subsystem; Protocol specification".
- [44] IETF RFC 4119 "A Presence-based GEOPRIV Location Object Format".
- [45] IETF RFC 4575: "A Session Initiation Protocol (SIP) Event Package for Conference State".
- [46] IETF RFC 5628: "Registration Event Package Extension for Session Initiation Protocol (SIP) Globally Routable User Agent URIs (GRUUs)".
- [47] IETF RFC 3863 "Presence Information Data Format (PIDF)".
- [48] IETF RFC 4745: "Common Policy: A Document Format for Expressing Privacy Preferences".
- [49] 3GPP TS 27.007: "AT command set for 3G User Equipment (UE)".
- [50] 3GPP TS 34.229-4: 'User Equipment (UE) conformance specification; Part 4: Enabler for IP multimedia applications testing'.

3 Definitions and abbreviations

3.1 Definitions

For the purposes of the present document, the terms and definitions given in 3GPP TR 21.905 [1] and 3GPP TS 34.229-1 [5] apply.

3.2 Abbreviations

For the purposes of the present document, the abbreviations given in 3GPP TR 21.905 [1] and 3GPP TS 34.229-1 [5] apply.

4 Requirements on the TTCN development

A number of requirements are identified for the development and production of TTCN specification for 3GPP UE at the Gm reference point.

1. Top-down design, following 3GPP 34.229-1 [5], 3GPP TS 34.123-1 [2], 3GPP TS 34.108 [7].
2. A unique testing architecture and test method for testing all protocol layers of UE.
3. Uniform TTCN style and naming conventions.
4. Improve TTCN readability.
5. Using TTCN-3 (ES 201 873-1 [12]).
6. TTCN specification feasible, implementable and compilable.
7. Test cases shall be designed in a way for easily adaptable, upwards compatible with the evolution of the 3GPP core specifications and the future Releases.
8. The test declarations, data structures and data values shall be largely reusable.
9. Modularity and modular working method.
10. Minimizing the requirements of intelligence on the emulators of the lower testers.
11. Giving enough design freedom to the test equipment manufacturers.
12. Maximizing reuse of RFC BNF definitions from the relevant IETF core specifications.

In order to fulfil these requirements and to ensure the investment of the test equipment manufacturers having a stable testing architecture for a relatively long period, a unique testing architecture and test method are applied to the 3GPP UE protocol tests.

5 Test method and test model

5.1 Test method

5.2 IMS CC test model

The test model is shown in figure Figure 5.2-1.

The IMS CC test cases are executed on top of the multi-testers test model according to 36.523-3[30]. To support this approach, the following test model is used.

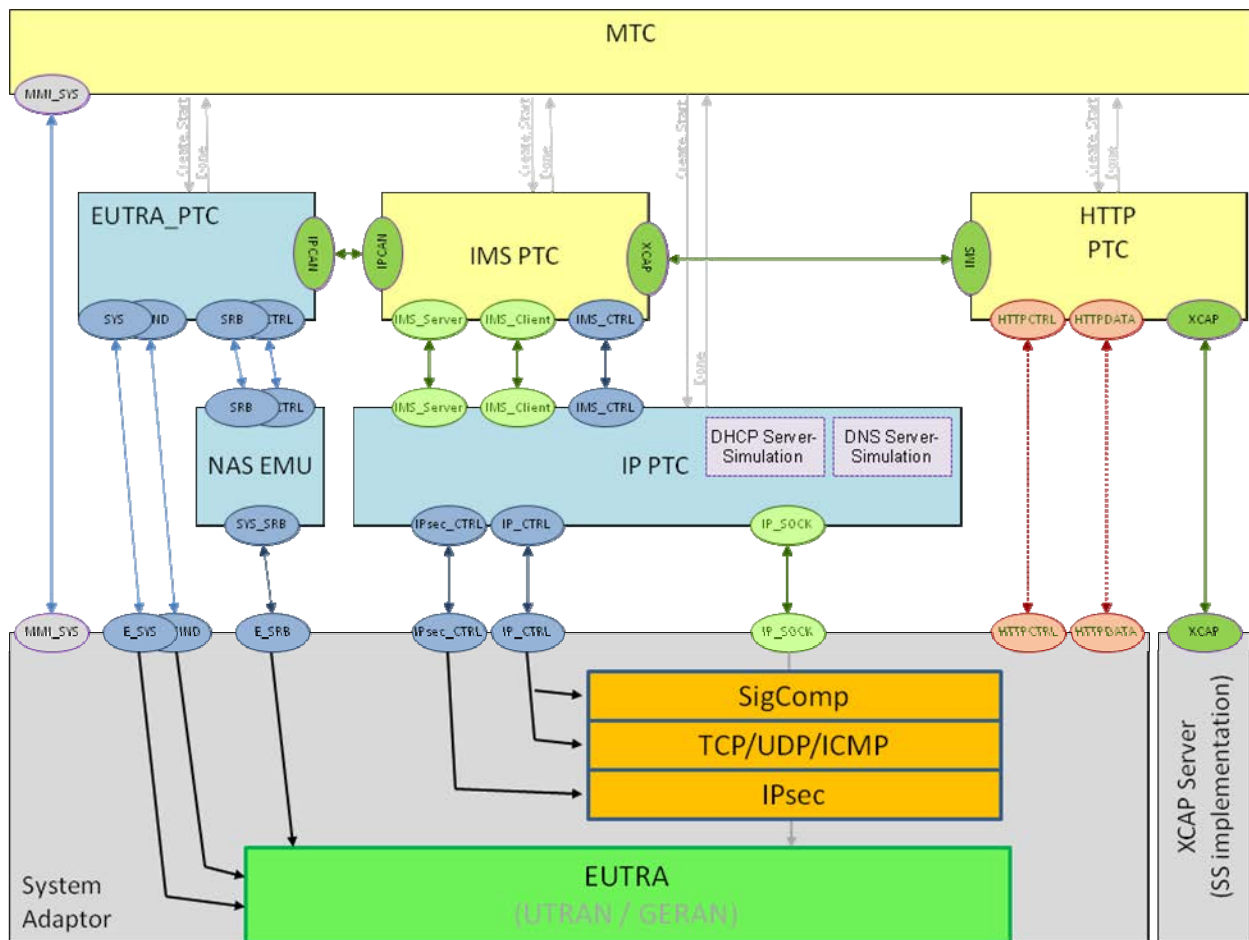

Figure 5.2-1: Extension to the Test Model to support 36.523-3 SS interface

The IMS CC test cases run on the IMS-PTC which controls the IPCanEmu and the IP-PTC. IPCanEmu is responsible for cell setup and DRB establishment and the IP-PTC controls the IP related configurations. IPCanEmu and IP-PTC interface to the SS according to 36.523-3[30].

Clauses 4.2.4 and 4.2.5 of 36.523-3 [30] describe the common handling of IP data in the multi-testers model regarding IMS signalling. In addition when a test case requires support of XCAP the SS needs to extend routing and handling of the IP data so that it can manage the security for the respective HTTP data, provide information of HTTP request and process information for HTTP responses according to ASP definitions in clause 6.4. The configuration of this extension is done by HTTP_CTRL_REQ as defined in clause 6.4. The SS gets information about:

- IP address and port of the simulated XCAP server
- IP address and port of the simulated BSF server
- DRB info: RAT, cell id and radio bearer id

With the information the SS can control IP packets with HTTP content to be routed from/to an HTTP server implementation supporting TLS as illustrated by Figure 5.6-2. Clause 5.5 provides further information regarding support of XCAP.

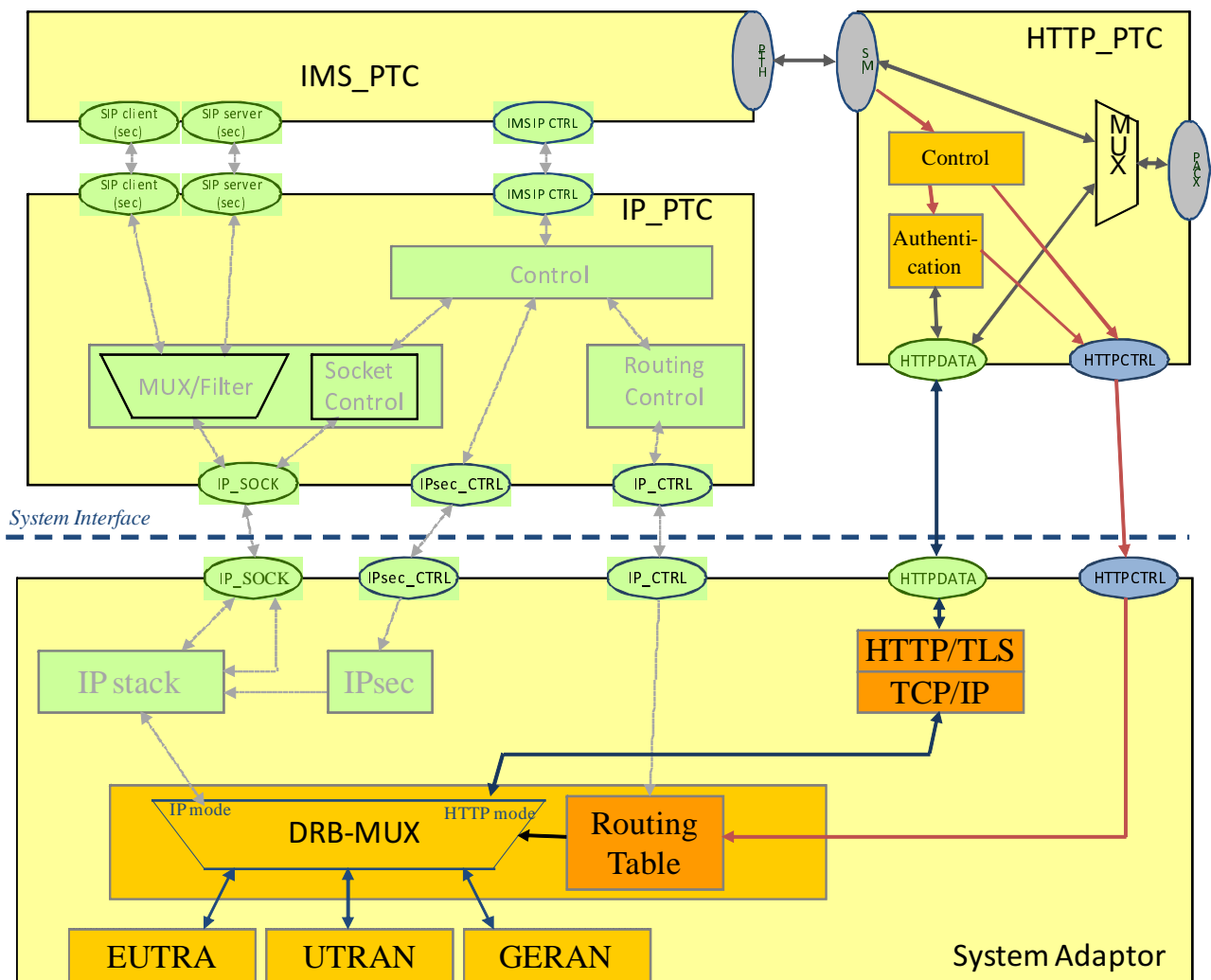

Figure 5.2-2: Extended IP model to handle HTTP/XCAP data

NOTE: Figure 5.2-2 is just an example; further details are SS implementation dependent.

5.3 Upper Tester (UT)

The upper tester interface is the same as defined in TS 36.523-3 clause 5 with additional, IMS-specific MMI commands as specified in annex B.2.

5.4 TTCN-3

TTCN is used as specification language. ES 201 873 [12] (TTCN-3) is applied to the notation.

5.5 Support of XCAP

MSTI supplementary services (TS 24.173[25]) like communication barring (CB) and communication diversion (CDIV) require the XCAP protocol (RFC 4825[26]) for transporting and manipulating XML documents in the network describing these services. Test cases for these services are specified in TS 34.229-1 clause 15. In order to support test case development, the test model shown in Figure 5.2.1.3-1 describes a PTC to handle HTTP requests from the UE and an external XCAP server as illustrated in Figure 5.5-1 below. There are specific ASPs to communicate with the XCAP server and for configuring the HTTP layer and for transferring data from the TTCN engine to the HTTP layer.

Figure 5.5-1 shows the Http/TLS layer of the test model within the SS connected to the TTCN component executing the test cases; and to the BSF module (Bootstrapping Server Function, see TS 33.220[34]) needed for implementing the GAA authentication.

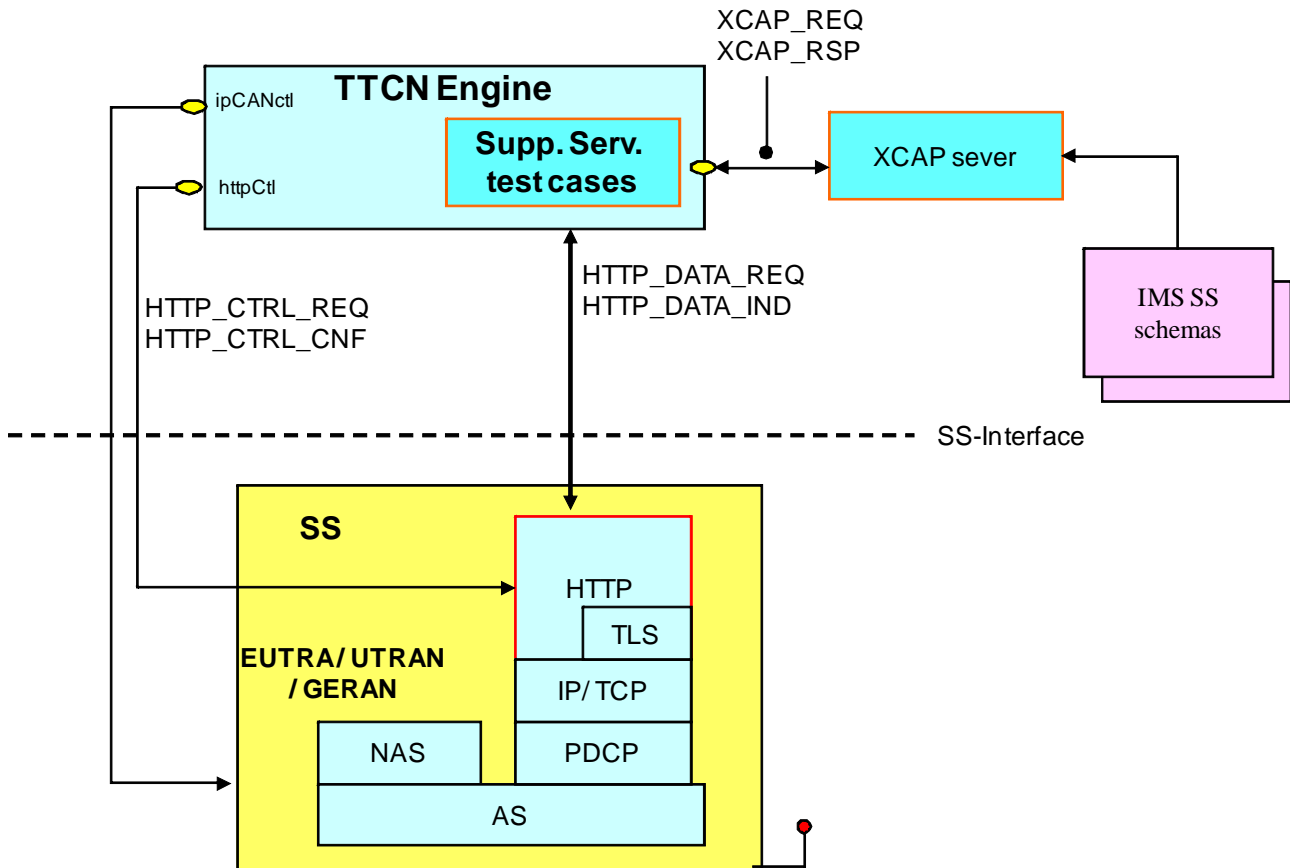

Figure 5.5-1: Extension to the Test Model to support XCAP

5.5.1 XCAP Server

Supplementary services are managed by the XCAP server in the *simservs* documents according to TS 24.623 [36]. Test cases manipulating data related to supplementary services are specified in TS 34.229-1 [5] clause 15. For simplification of the TTCN implementation, the XCAP server functionality shall be provided by the SS i.e. it is not implemented in the TTCN. Access to the XCAP server can be distinguished into:

- HTTP based transaction between the UE and the XCAP server
- Initialisation and validation of the *simservs* document according to the test cases

In addition the UE may exchange HTTP messages for authentication (depending on the UE's security capabilities); see figure 5.5.1-1.

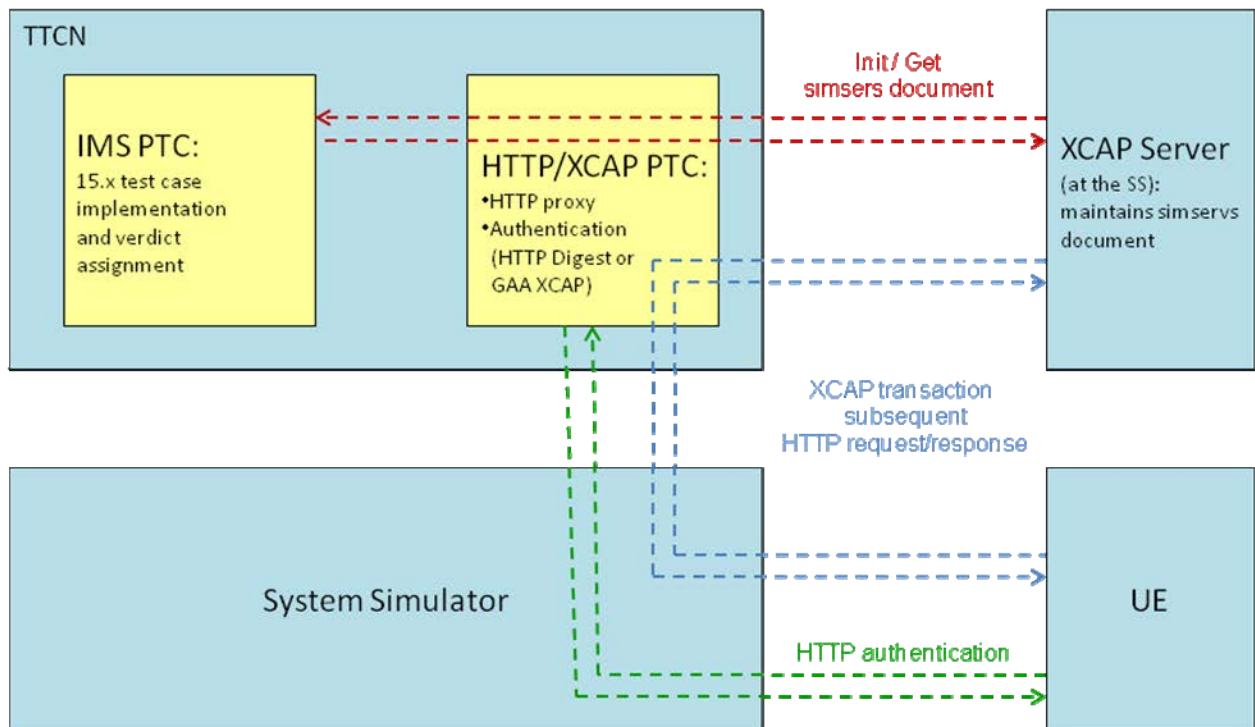

Figure 5.5.1-1: IMS CC test model

NOTE: In accordance to RFC 4825 clause 6.3 [26], the UE may use complex XPATH expressions to modify the simservs document but this shall be handled by the XCAP server; in the TTCN these expressions are not explicitly checked. Furthermore test case implementation itself does not use complex XPATH expressions to access the simservs document, but always considers the whole document.

5.5.2 HTTP Signalling

RFC 4825 [26] specifies the protocol for accessing user data in the XCAP server via HTTP requests. An HTTP request for an XCAP operation contains basically three components:

- Request line method, i.e. PUT, GET or DELETE
- Request line uri - The XCAP expression to be evaluated to access the XCAP document. The XCAP expression consists of the document selector followed by the separator '~~' followed by the node selector pointing to the user data to accessed or evaluated
- body - Describing the value (an xml fragment) referenced by the XCAP expression

Example 1

In order to set terminating-identity-presentation for user sip:ob.stf160@etsi.org, the UE sends following HTTP request:

```
PUT http://XCAP-Server/simservs.ngn.etsi.org/users/sip%3Aob.stf160%40etsi.org/simservs.xml/~~/simservs/terminating-identity-presentation/%40active
Body: true
```

If successful, the XCAP server responds with

```
HTTP/1.1 200 OK
```

Example 2

To get the value of terminating-identity-presentation for user sip:ob.stf160@etsi.org, the UE sends following HTTP request:

GET http://XCAP-Server/simservs.ngn.etsi.org/users/sip%3Aob.stf160%40etsi.org/simservs.xml/~~/simservs/terminating-identity-presentation/%40active

If successful, the XCAP server responds with

HTTP/1.1 200 OK
Body: true

In this example

```
//XCAP-server/simservs.ngn.etsi.org/users/ sip%3Aob.stf160%40etsi.org/simservs.xml/-
Document selector for user sip:ob.stf160@etsi.org.
~~ - Document selector separator, see RFC 4825
/simservs/terminating-identity-presentation/%40active - Node selector pointing to the information in
the XCAP server to be accessed. This is an XPATH expression, see RFC 4825 section 6.3.
true - Is the xml fragment (in this case very simple) to be set as value of the XPATH expression
```

Following operations shall be implemented in the XCAP server, see RFC 4825.

GET - Returns the requested data as an XML fragment to be send to the UE

input parameters: charstring documentSelector, charstring xpathExpr

returns: XML fragment or XML document

PUT - Builds an XML subtree or sets an attribute given by the xmlFragment at the position pointed by the xpath expression

input parameters: charstring documentSelector, charstring xpathExpr, charstring xmlFragment or xmlDocument

DELETE - Deletes an XML subtree or sets an attribute given by the xmlFragment at the position pointed by the xpath expression

input parameters: charstring documentSelector, charstring xpathExpr

5.6 Void

6 ASP definitions

6.1 Void

6.2 Void

6.3 Void

6.4 HTTP Layer ASP definitions

HTTP Layer ASPs are applicable to clause 5.2. and 5.6.

Name	HttpRoutingInfo_Type	
Comment	Routing info to distinguish HTTP data for XCAP server and BSF.	
Parameter Name	Parameter Type	Comment
serverAddr	charstring	IP address of simulated server
serverPort	integer	Port number of simulated server

Name	HTTP_DATA_IND	
Port	HTTP_DATA_PORT	
Comment	ASP type for sending a message from the http layer to the TTCN. It transports relevant information of a http Request from the UE to the Tester.	
Parameter Name	Parameter Type	Comment
routingInfo	HttpRoutingInfo_Type	to distinguish BSF and XCAP server
httpRequest	HttpRequest_Type	See below

Name	HttpRequest_Type	
Comment		
Parameter Name	Parameter Type	Comment
requestLine	HttpRequestLine_Type	Request-Line in RFC 2616 [27] clause 5.1
authorization	Authorization	Authorization in RFC 2616 [27] clause 14.8 (optional; NOTE 1)
contentType	ContentType	Content-Type in RFC 2616 [27] clause 14.17 (optional, NOTE 1)
x3GPPIntendedIdentity	charstring	3GPP TS 24.109 [33] clause G.2 (optional)
messageBody	charstring	MTSI XCAP Message (optional)
NOTE 1: Same type definition as for SIP type definitions.		

Name	HttpRequestLine_Type	
Comment	request line according to RFC 2616 [27] clause 5.1.	
Parameter Name	Parameter Type	Comment
method	charstring	
uri	charstring	XCAP selection expression, RFC 4825 [26]
version	charstring	

Name	HTTP_DATA_REQ	
Port	HTTP_DATA_PORT	
Comment	ASP type for sending messages from the TTCN to the http layer. It transports information needed by the http layer to generate a http Response to the UE.	
Parameter Name	Parameter Type	Comment
routingInfo	HttpRoutingInfo_Type	to distinguish BSF and XCAP server
httpResponse	HttpResponse_Type	See below

Name	HttpResponse_Type	
Comment		
Parameter Name	Parameter Type	Comment
statusLine	HttpStatusLine_Type	Status-Line in RFC 2616 [27] clause 6.1
wwwAuthenticate	WWWAuthenticate	WWW-Authenticate in RFC 2616 [27] clause 14.47 (optional; NOTE 1)
authenticationInfo	AuthenticationInfo	Authentication-Info in RFC 2617 [37] clause 3.2.3 (optional; NOTE 1)
contentType	ContentType	Content-Type in RFC 2616 [27] clause 14.17 (optional; NOTE 1)
expires	Expires	Expires in RFC 2616 [27] clause 14.21 (optional; NOTE 1)
messageBody	charstring	MTSI XCAP Message (XML document or XML fragment) (optional)
NOTE 1: Same type definition as for SIP type definitions.		

Name	HttpStatusLine_Type	
Comment	status line according to RFC 2616 [27] clause 5.1.	
Parameter Name	Parameter Type	Comment
version	charstring	
code	integer	
reasonPhrase	charstring	

Name	HttpAuthenticationMechanism_Type	
Type	enumerated	
Parameters	noAuthentication, httpDigestAuthentication, gaaAuthentication	
Comment	authentication mechanism to be applied for HTTP signalling: noAuthentication: no authentication (NOTE) httpDigestAuthentication: HTTP digest authentication according to 24.623[36] clause 5.2.3.2 and RFC 2617 [37] gaaAuthentication: GAA based authentication according to 33.222 [35] and 24.109 [33]	
NOTE: In general 'no authentication' is not applicable to conformance testing		

Name	HTTP_CTRL_REQ	
Port	HTTP_CTRL_PORT	
Comment	ASPTYPE to configure the http layer When any of the optional fields is omitted the SS shall continue with the previous configuration of this field.	
Parameter Name	Parameter Type	Comment
authenticationMechanism	HttpAuthenticationMechanism_Type	Authentication mechanism
tlsInfo	TLSInfo_Type	Description of the TLS connection to be used (optional)
xcapServer	HttpRoutingInfo_Type	IP address and port of simulated XCAP server (optional)
bsfServer	HttpRoutingInfo_Type	IP address and port of simulated BSF server (optional)
drblInfo	IP_DrblInfo_Type	(optional) NOTE 1, 2
NOTE 1: Whether this parameter is used by the SS depends on SS implementation and on which test model is used; if the SS does not need the information it may just ignore it.		
NOTE 2: 'IP_DrblInfo_Type' is imported from common definitions of the LTE model (TS 36.523-3 [30]).		

Name	TLS_Type	
Type	enumerated	
Parameters	noTLS, pskTLS, certTLS	
Comment	Type of TLS connection to be used (if any)	

Name	TLS_CIPHER_Type	
Type	enumerated	
Parameters	noCipher, psk_3DES_EDE_CBC_SHA, psk_AES_128_CBC_SHA	
Comment	Cipher suite to be used	

Name	TLSInfo_Type	
Comment		
Parameter Name	Parameter Type	Comment
tlsType	TLS_Type	Type of TLS connection to be used (if any)
psk	octetstring	Pre shared key for TLS ciphering
cipherSuite	TLS_CIPHER_Type	Cipher suite to be used

Name	HTTP_CTRL_CNF	
Port	HTTP_CTRL_PORT	
Comment	ASP type to confirm HTTP_CTRL_REQ	
Parameter Name	Parameter Type	Comment
errorInfo	charstring	string indicating a system error (optional)

6.5 XCAP server ASP definitions

XCAP Layer ASPs are applicable to clause 5.2. and 5.6.

Name	XCAP_REQ	
Port	XCAP_PORT	
Comment	ASP type for sending a request to the external XCAP server according to RFC 4825 [26]	
Parameter Name	Parameter Type	Comment
method	charstring	GET, PUT, DELETE or RESET
xcapExpression	charstring	XCAP expression sent by the UE in its http request line
contentType	charstring	media type as contained in the HTTP content type header (optional)
xmlBody	charstring	XML fragment sent by the UE in its http body or sirmservs document initialised by the test cases (optional)

Name	XCAP_RSP	
Port	XCAP_PORT	
Comment	ASP type for sending the response to the XCAP_REQ from the XCAP server to TTCN	
Parameter Name	Parameter Type	Comment
errorInfo	charstring	string indicating a system error (optional)
contentType	charstring	media type as contained in the HTTP content type header (optional)
xmlBody	charstring	Result returned by the XCAP server (optional)

7 Codec definitions for IP User Data

7.1 Introduction

SIP is a text-based protocol, thus the message exchange between the UE and the SS are pure character strings. In the TTCN-3 ATS the messages are structured and optimized to take the advantage of TTCN-3 functionality, and to make the debugging and maintenance of the ATS easier.

7.2 General Aspects

IP user data for IMS conformance testing can be distinguished into:

1. text based: SIP (including SDP and XML messages), HTTP (see clause 7.4)
2. octetstring based: DHCP, DHCPv6, DNS (see clause 7.4)

In TTCN the following encoding information is used for user data:

Table 7.2-1

Type definitions	Encoding
SMS Types	Tabular notated (see note 1)
DHCPv4-Codec	Tabular notated (see note 1)
DHCPv6-Codec	Tabular notated (see note 1)
DNS-Codec	Tabular notated (see note 1)
SIPCodec	(see clause 7.3)
SDPCodec	(see clause 7.3)
HttpCodec	(see clause 7.3)

NOTE 1: Tabular notated is performed by concatenation of all the present fields in the TTCN-3 template.

NOTE 2: Encoding information is only needed for type definitions of peer-to-peer signalling; encoding of ASPs used for system configuration or as co-ordination messages between PTCs is out of scope for this document.

7.3 Requirements on abstract message syntax for IMS (SIP, SDP)

7.3.1 Type definition - Syntax / Semantic aspects

All given defined BNF grammars (e.g. the ABNF of RFC 3261) are unique. Thus the syntax tree for each syntactically correct message derived with these grammars are unique too and the parts of a message can be uniquely identified (represented) by the terminal phrase belonging to a non terminal symbol and its derivation path in the syntax tree.

The syntax tree of all given messages can be used to uniquely identify and describe the parts of the messages. The leaves are the part of every message and the nodes from the root to the leaves represent the sequence of rules to be applied to derive that part

The IMS/SIP root message type is an ordered structured type, which is represented as a record type in TTCN-3. For each grammar rule of the ABNF a TTCN-3 record type is declared with the specific name of the rule. The following rules are applied to the fields within a record:

- A non-terminal symbol is declared as a record type for this symbol.
- The order of the symbols in the rule are represented by an equal order of the fields.
- Repetitions are declared as 'set of' or 'record of' types.
- Options are represented as optional record/set fields.
- Alternatives are declared as union types.

7.3.2 Deviations of the type definition semantic

- Most of the 'literals' of a message (for example: the string "Via" or "v" in the message header fields) are not represented.
- The TTCN-3 charstring type is used where we stop structuring even if the ABNF uses structured types. More details found in clause 8.3.3.
- Wherever possible parts are mapped to their best type representation, e.g. DIGIT based rules are mapped to integer type not to a charstring type.
- All of the following delimiters (including preceding or following whitespace) defined by the ABNF grammar to separate the parts of a message are not represented (see note).

```

STAR      = SWS "*" SWS ; asterisk
SLASH     = SWS "/" SWS ; slash
EQUAL     = SWS "=" SWS ; equal
LPAREN    = SWS "(" SWS ; left parenthesis

```

```

RPAREN = SWS ")" SWS ; right parenthesis
RAQUOT = ">" SWS ; right angle quote
LAQUOT = SWS "<"; left angle quote
COMMA  = SWS "," SWS ; comma
SEMI   = SWS ";" SWS ; semicolon
COLON  = SWS ":" SWS ; colon
LDQUOT = SWS DQUOTE; open double quotation mark
RDQUOT = DQUOTE SWS ; close double quotation mark
HCOLON = *( SP / HTAB ) ":" SWS
SP      = single space
HTAB    = tab
SWS     = sep whitespace

```

NOTE: If they are present within a pure charstring they will be handled like a normal character and are still included.

- Messages which are not of interest to the test suite are left undecoded as a charstring and will not be further structured.

Further clarifications on the handling of delimiters are provided hereafter:

In many cases the TTCN-3 type definitions are of lower granularity than the BNF and the codec shall consider the TTCN type definitions only. Therefore as stated in the NOTE above the rules for handling of delimiters do not require delimiters to be blindly removed from strings but the codec shall only deal with the delimiters needed to encode/decode the TTCN-3 types; sub-structures of the BNF being mapped to TTCN-3 charstrings need to be handled in TTCN and are out of scope of the codec implementation.

Example 1:

According to the BNF Alert-Info is defined as

```

Alert-Info = "Alert-Info" HCOLON alert-param *(COMMA alert-param)
alert-param = LAQUOT absoluteURI RAQUOT *( SEMI generic-param )

```

The corresponding TTCN-3 type definition is

```

type record AlertInfo {
  fieldName fieldName (ALERT_INFO_E),
  AlertInfoBody_List alertInfoBody optional }
type set of AlertInfoBody AlertInfoBody_List;
type record AlertInfoBody {
  charstring url,
  SemicolonParam_List genericParams optional }

```

⇒ LAQUOT and RAQUOT are delimiters of the URI field which shall be removed by the codec in UL.

Example 2:

Some fields according to the BNF for SIP are defined as '(token LWS)/ quoted-string', i.e. the field can be either a (case-insensitive) token or a quoted string. In general in TTCN this can be mapped

- a) to a charstring or
- b) to a union of two charstring (one for the token, one for the quoted string).

In case of a) the codec shall preserve the double-quotes for the quoted-string as otherwise it cannot be distinguished from a token anymore which is vital when case-sensitivity matters whereas in case of b) the double quotes shall be removed.

7.3.3 Additional requirements for codec implementations (SIP/IMS Message)

The SIP/IMS codec is based on a normalized encoding which is always produced by an encoder. Decoder implementations, however, have to handle normalization before, or when constructing the structured message value, e.g. long versus compact form, whitespace compression, delimiter removal, same header grouping, etc. All these aspects will be handled in the next clause.

7.3.3.1 Differences between BNF - TTCN-3 Type Mapping

In normal cases the mapping is straight forward. Below you find the exceptions, including potential examples.

- The root message type is not a SIP-message but directly a Request or Response type which is represented as a TTCN-3 record. All Method - Message names (INVITE, BYE, ACK etc.) and all message header field names (To, From, CallID, CSeq, Via etc.) are mapped to an enumerated type in TTCN-3 to simplify the extension of new headers. During encoding, the long-form of these message header fields is always used. The respective field in the header type is restricted to values which are allowed.

BNF rules of RFC	TTCN-3 Type Mapping
SIP-message = Request / Response	type record REGISTER_Request {...}, type record INVITE_Request {...}, type record PRACK_Request {...}, type record NOTIFY_Request {...}, type record UPDATE_Request {...}, ... type record Response {...}

Method = INVITEm / ACKm / OPTIONSm / BYEm / CANCELm / REGISTERm / ...	type enumerated Method { ACK_E, BYE_E, CANCEL_E, INVITE_E, OPTIONS_E, REGISTER_E, ...}
-----------------------------------------------------------------------------------------	----------------------------------------------------------------------------------------

- The structure of the message header fields are mapped to a "set " type in TTCN-3, because the order of these header fields is not mandatory. There is an Unknown Header List given in the type system to decode unknown headers with ID and Value.

message-header = (... / Contact / Content-Disposition ... / Via / Warning / WWW-Authenticate / extension-header) CRLF	type set MessageHeader { ... Contact contact optional, ContentDisposition contentDisposition optional, ... Via via, Warning warning optional, WwwAuthenticate wwwAuthenticate optional, UndefinedHeader_List undefinedHeader_List optional }
------------------------------------------------------------------------------------------------------------------------------------------------	-------------------------------------------------------------------------------------------------------------------------------------------------------------------------------------------------------------------------------------------------------------------------

- The various parameter lists defined in the BNF are mapped and combined into three different TTCN-3 sets of generic-param types. These types differ only in their name: SemicolonParam_List, AmpersandParam_List, CommaParam_List to distinguish between the relevant separators.

uri-parameters = *(";" uri-parameter)	type set of GenericParam SemicolonParam_List;
Authentication-Info = "Authentication-Info" HCOLON ainfo *(COMMA ainfo)	type record AuthenticationInfo { FieldName fieldName(AUTHENTICATION_INFO_E), CommaParam_List ainfo }
ainfo = nextnonce / message-qop / response-auth / cnonce / nonce-count	type set of GenericParam CommaParam_List;
Headers = "?" header *("&" header)	type set of GenericParam AmpersandParam_List;

- Any more specific parameter rule (e.g. uri-param, user-param, lr-param , digest-cln, etc.) is simplified to the generic-param rule which will be mapped as a record structure of two charstrings (ID and paramValue). This is equivalent to a token with an optional generic value (token [EQUAL gen-value]).

digest-cln =	realm / domain / nonce / opaque / stale / algorithm / qop-options / auth-param	type record GenericParam { charstring id , charstring paramValue optional }
--------------	-----------------------------------------------------------------------------------------------------	---------------------------------------------------------------------------------------------

- In addition to the pure charstring as a base type, the TTCN-3 type system provides base integer types which are unrestricted to the model e.g. the portField, CSeq number, maxForward digit.

user =	1*(unreserved / escaped / user-unreserved)	charstring
telephone-subscriber	as defined in RFC 2806	
password =	*(unreserved / escaped / "&" / "=" / "+" / "\$" / ",")	charstring

Port =	1*DIGIT	integer
Status-Code =	Informational / Redirection / Success / Client-Error / Server-Error / Global-Failure / extension-code	integer

- Where the same header type can appear multiple times within a message, they will be decoded as a single header field, with multiple list elements. The order of appearance of the headers will be preserved within the header list value.

Contact =	("Contact" / "m") HCOLON (STAR / (contact-param *(COMMA contact-param)))	type record Contact { FieldName fieldName(CONTACT_E), ContactBody contactBody }
contact-param =	(name-addr / addr-spec) *(SEMI contact-params)	type record ContactAddress { Addr_Union addressField, SemicolonParam_List contactParams optional } type union ContactBody { charstring wildcard, ContactAddress_List contactAddresses } Used in type set of ContactAddress ContactAddress_List;

- The BNF (clause 7.3.1 Header Field Format RFC 3261 [16]) specifies that several WWW or Proxy Authentication/Authorization headers should not be combined into a single header; however they will be decoded into such in the codec. If these need to be sent downlink then a new, 'raw' (pure charstring) message type will be introduced.

Authorization =	"Authorization" HCOLON credentials	type record Authorization { FieldName fieldName(AUTHORIZATION_E), Credentials body }
Credentials =	("Digest" LWS digest-response) / other-response	type union Credentials { CommaParam_List digestResponse, OtherAuth otherResponse }

- The different schemes (sip, sips, tel, fax, absoluteUri) in the SIP URI are all handled via the same type definition. The union 'UriComponents' can be enhanced to support further specific URI formats. Nevertheless it is possible to use the 'other' branch of 'UriComponents' for any other URI format in which case the charstring shall contain the URI without the scheme and the first '!'.

Request-URI =	SIP-URI / SIPS-URI / absoluteURI	type record SipUriComponents { // sip-uri acc. to RFC 3261 [16] cl. 19.1 UserInfo userInfo optional, HostPort hostPort }
with		
SIP-URI =	"sip:" [userinfo] hostport uri-parameters [headers]	type record TelUriComponents { // tel-uri acc. to RFC 3966 [38] charstring subscriber }
and		type record UrnUriComponents { // urn-uri acc. to RFC 2141 [39] charstring namespaceId, // e.g. "service" charstring namespaceSpecificString // e.g. "sos" }
SIPS-URI =	"sips:" [userinfo] hostport uri-parameters [headers]	type union UriComponents { SipUriComponents sip, // scheme: "sip" or sips" TelUriComponents tel, // scheme: "tel" UrnUriComponents urn, // scheme: "urn" charstring other }
and		
absoluteURI =	scheme ":" (hier-part / opaque-part)	type record SipUri { charstring scheme , UriComponents components, SemicolonParam_List urlParameters optional, AmpersandParam_List headers optional }type record SipUri { charstring scheme , UserInfo userInfo optional, HostPort hostPort, SemicolonParam_List urlParameters optional, AmpersandParam_List headers optional }

- Universal charstrings shall be supported by the codec especially for the Display name in the URI.
- For downlink messages, if a message body is included, the TTCN may set the len field in the ContentLength header to the value -1. In this case the codec shall replace the value by the actual length of the encoded message body (see clause 7.3.4).
- According to the SIP type definitions there are many "charstring" fields being optional in records;
⇒ in UL the decoder shall map missing information by setting the respective field to omit rather than by assigning an empty string (").
- type union Addr_Union
As in 'NameAddr' the field 'displayName' is optional in the first place the two branches of 'Addr_Union' are equivalent when there is no 'displayName'; nevertheless in UL the decoder shall use the branch "nameAddr" if –

and only if – the address information is surrounded by "<" and ">" (what is needed at least when there is a display name followed by the address information)

- IPv6 address in URI
When an IPv6 address is used as hostname in a SIP URI it is typically surrounded by "[" and "]" what is matter of the codec: in DL the codec shall add "[" and "]" when needed, in UL the "[" and "]" shall be removed i.e. in the "host" field of the SipUriComponents" hostPort there shall be no "[" or "]" at the beginning or at the end.

7.3.3.2 URL Encoding

Several fields or parameters in SIP headers require URL encoding (e.g. Contact header, Accept-Contact header). In TTCN there is no encoding rule defined for URL encoding and there is no specific type definition for URL encoded strings. For that reason URL encoding/decoding is not a matter of codec implementation but shall be done in TTCN.

7.3.4 Additional requirements for codec implementations (Message Body)

The message body of a SIP message may contain the message of other protocols (SDP, SMS, etc.) and can be represented e.g. by XML. Therefore the type definitions for these protocols can be TTCN-3 as well as XSD definitions.

As in principle the message body of a SIP message may host any XSD definition, SIP and XSD definitions are decoupled:

To avoid import of all potential XSD definitions the XML body of SIP messages is defined as a charstring. This requires a two-stage encoding and decoding: In DL an XML message needs to be encoded in TTCN first before it gets put in the message body of a SIP message, in UL the XML message contained in the message body needs to be explicitly decoded in TTCN. By defining the XML message body as a charstring the SIP definitions are independent from any XSD definitions and a specific XSD definition needs to be known only when it is really used.

An SDP message may be contained in the message body itself or in a MIME message. In both cases the SDP message is represented as charstring in the SIP message and as for XML a two-stage encoding and decoding is applied in TTCN. This allows explicit fail assignments in case of syntactically incorrect SDP messages when syntactical correctness is a test requirement.

NOTE: Test specifications (e.g. TS 34.229-1 [5]) define the criteria for syntactical correctness and codec implementations follow these criteria.

In detail the message body for SIP messages is defined as:

```

type charstring XmlBody;
type charstring SdpBody;

type union MessageBody {
  SdpBody          sdpMessageBody
  XmlBody          xmlBody,
  MIME_Message    mimeMessageBody,
  charstring       sipfrag,
  charstring       textplain,
  SimpleMsgSummarysimpleMsgSummary,
  octetstring      smsMessage
};

```

NOTE: In contrast to SIP and SDP definitions which are commonly defined by ETSI the definition of the message body is project specific i.e. other IMS test projects at ETSI may use different definitions of the message body.

7.3.5 Additional requirements for codec implementations (SDP Body)

The Session Description Protocol is defined in RFC 4566.

- The 'type' fields (such as 'v' and 'o' are not represented).

- For the defined attributes, the att-field is also not represented (e.g. 'curr' is not represented in SDP_attribute_curr).
- The Messages which are not of interest to a test suite are left undecoded as a charstring and will not be further structured.

7.3.5.1 Differences between BNF - SDP Type Mapping

In normal cases the mapping is straight forward. Below are the exceptions which differ.

- The numerical fields in the origin-field, the time-field and the timezone field have been defined as charstring because they may not fit into a 32-bit signed integer.

BNF Rules of RFC 4566	TTCN 3 Type Mapping
origin = username sess-id sess-version nettype addrtype unicast-address	type record SDP_Origin { charstring username, charstring session_id, charstring session_version, charstring net_type, charstring addr_type, charstring addr }
time-fields = start-time stop-time repeat-fields [zone-adjustments]	type record SDP_time_field { charstring start_time, charstring stop_time }
zone-adjustments = time typed-time	type record SDP_timezone { charstring adjustment_time, SDP_typed_time offset }

- The zone-adjustments field in the time-fields has been included as an additional field in the top-level message definition.

BNF Rules of RFC 4566	TTCN 3 Type Mapping
session-description = proto-version origin-field session-name-field information-field uri-field email-fields phone-fields connection-field bandwidth-fields time-fields key-fields attribute-fields media-descriptions	type record SDP_Message { integer protocol_version, SDP_Origin origin, charstring session_name, charstring information optional, charstring uri optional, SDP_email_list emails optional, SDP_phone_list phone_numbers optional, SDP_connection connection optional, SDP_bandwidth_list bandwidth optional, SDP_time_list times, SDP_timezone_list timezone_adjustments optional, SDP_key key optional, SDP_attribute_list attributes optional, SDP_media_desc_list media_list optional }
time-fields = start-time stop-time repeat-fields [zone-adjustments]	type record SDP_time { SDP_time_field time_field, SDP_repeat_list time_repeat optional }

- The mappings for the email-address, phone-number and connection-address fields have been simplified.

BNF Rules of RFC 4566	TTCN 3 Type Mapping
email-address = address-and-comment / dispname-and-address / addrspec	type record SDP_contact { charstring addr_or_phone, charstring disp_name optional }
phone-number = email-safe / email-safe "<" phone ">" / phone	type record SDP_contact { charstring addr_or_phone, charstring disp_name optional }
connection-address = multicast-address / unicast-address	type record SDP_conn_addr { charstring addr, integer ttl optional, integer num_of_addr optional }

7.3.5.2 Defined attributes

The SDP_attribute type is defined as a union of the following attribute types. There is an unknown attribute given to decode undefined attributes with a name and value.

SDP Attribute	TTCN 3 Type Mapping
cat	type record SDP_attribute_cat { charstring attr_value }
charset	type record SDP_attribute_charset { charstring attr_value }
conf	type record SDP_attribute_curr { charstring preconditionType, charstring statusType, charstring direction }
curr	type record SDP_attribute_curr { charstring preconditionType, charstring statusType, charstring direction }
des	type record SDP_attribute_des { charstring preconditionType, charstring strength, charstring statusType, charstring direction }
fntp	type record SDP_attribute_fntp { charstring attr_value }
framerate	type record SDP_attribute_framerate { charstring attr_value }
inactive	type record SDP_attribute_inactive { }
keywds	type record SDP_attribute_keywds { charstring attr_value }
lang	type record SDP_attribute_lang { charstring attr_value }
orient	type record SDP_attribute_orient { charstring attr_value }
ptime	type record SDP_attribute_ptime { charstring attr_value }

SDP Attribute	TTCN 3 Type Mapping
quality	type record SDP_attribute_quality { charstring attr_value }
recvonly	type record SDP_attribute_recvonly { }
rtcp	type record SDP_attribute_rtcp { charstring attr_value }
rtpmap	type record SDP_attribute_rtpmap { charstring attr_value }
sdplang	type record SDP_attribute_sdplang { charstring attr_value }
sendrecv	type record SDP_attribute_sendrecv { }
sendonly	type record SDP_attribute_sendonly { }
Tool	type record SDP_attribute_tool { charstring attr_value }
Type	type record SDP_attribute_type { charstring attr_value }
Unknown	type record SDP_attribute_tool { charstring name, charstring attr_value optional }

7.3.6 Additional requirements for codec implementations (HTTP)

FFS

7.3.7 Additional requirements for codec implementations (XML)

XML data schema is used in IMS conformance testing according to ETSI ES 201 873-9. No further requirements are necessary.

7.4 Requirements for codec implementations (DHCP, DNS)

The DHCP/DNS codec converts TTCN descriptions into/from octet streams as specified in the RFCs. The TTCN type definitions for DHCP/DNS types closely follow the data formats defined in the corresponding RFCs (RFC 1035, RFC 1533, RFC 2131, RFC 3315, RFC 3319 and RFC 3361).

As a special case, when the TTCN length field in a DHCP/DNS record is set to 0 the encoder shall compute the proper length value during encoding.

8 Design consideration

8.1 Void

8.2 Void

8.3 Void

8.4 AT commands

All mandatory and optional AT commands are sent as AT command strings as defined above. If an optional AT command is not implemented in the UE, the system adaptor needs to parse the AT command and map it to an appropriate MMI command (which is out of scope for this document).

The following AT commands are applied in TTCN.

Table 8.4-1: AT Commands

Command
AT+CLIP
AT+CLIR
AT+COLP
AT+CCFCU
AT+CHLD
AT+CDU
AT+CHCCS
AT+CDEFMP
AT+COLR
AT+CCWA
AT+CNAP
AT+CLCK

AT commands are referred to TS 27.007 [49].

8.5 Timer Tolerances

For timers used in conformance test cases according to TS 34.229-1 [5], a tolerance of 10% shall be applied.

Annex A (normative): Abstract Test Suites (ATS)

This annex contains the approved ATSs.

The ATSs have been produced using the Testing and Test Control Notation version 3 (TTCN3) according to ES 201 873 [12].

A.1 Version of specifications

Table A.1 shows the version of the test specifications which the delivered ATSs are referred to.

Table A.1: Versions of the test and Core specifications

Core specifications	3GPP TS 24.229 [11]
Test specifications	3GPP TS 34.229-1 [5]
	3GPP TS 34.229-2 [6]
	3GPP TS 34.123-3 [2]
	3GPP TS 36.523-3 [30]

A.2 IMS-CC ATS

Table A.2 lists all approved test cases.

Table A.2: IMS-CC TTCN test cases

Test case	Description
8.1	Initial registration
8.2	User Initiated Re-Registration
8.3	Mobile Initiated Deregistration
8.4	Invalid behaviour- 423 Interval too brief
9.1	Invalid Behaviour – MAC Parameter Invalid
9.2	Invalid Behaviour – SQN out of range
10.1	Invalid Behaviour – 503 Service Unavailable
11.1	Network-initiated deregistration
11.2	Network initiated re-authentication
12.2	MO Call – 503 Service Unavailable
12.2a	MO Call – 504 Server Time-out
12.12	MO MTSI Voice Call Successful with preconditions
12.13	MT MTSI speech call
12.18	MTSI MO speech call / SSAC / 0% access probability for MTSI MO speech call
12.20	Emergency call / Success / SSAC / 0% access probability for MTSI MO speech call
15.8	Communication Forwarding on non reply: MO call initiation
15.11	MO Call Hold without announcement
15.12	MT Call Hold without announcement
15.27	Communication Waiting and answering the call
15.28	Communication Waiting and cancelling the call
16.2	Speech AMR, indicate selective codec modes
16.3	Speech AMR-WB, indicate all codec modes
16.4	Speech AMR-WB, indicate selective codec modes
18.1	Mobile Originating SMS
18.2	Mobile Terminating SMS
19.1.2	Emergency call with emergency registration / Success / Location information not available
19.4.1	Emergency call without emergency registration / EPS / UE does not contain an ISIM or USIM
19.4.5	Emergency call without emergency registration / UE credentials are not accepted
19.5.6	User-initiated emergency reregistration / UE has emergency related ongoing dialog
19.5.9	In parallel emergency and non-emergency registrations
19.5.10	Deregistration upon emergency registration expiration

The Test Suite in TTCN3 is contained in multiple ASCII files which accompany the present document.

A.2.1 Void

A.2.2 Void

A.2.3 Void

Annex B (normative): Partial IXIT proforma

Notwithstanding the provisions of the copyright related to the text of the present document, The Organizational Partners of 3GPP grant that users of the present document may freely reproduce the partial IXIT proforma in this annex so that it can be used for its intended purposes and may further publish the completed partial IXIT.

B.0 Introduction

This partial IXIT proforma contained in the present document is provided for completion, when the related Abstract Test Suite is to be used against the Implementation Under Test (IUT).

Text in *italics* is comments for guidance for the production of an IXIT, and is not to be included in the actual IXIT.

The completed partial IXIT will normally be used in conjunction with the completed ICS, as it adds precision to the information provided by the ICS.

B.1 Parameter values

B.1.1 PIXITs

Table B.1.1: PIXIT

Parameter name	Description	Type	Default value	Supported value
px_AssociatedTelUri	TEL URI for the user	charstring		format shall be TEL URI
px_CalleeUri	URI of Callee, send by the UE in INVITE (MO call establishment) to address the remote UE	charstring	"sip:User-B@3gpp.org"	
px_CalleeContactUri	URI provided by the remote side (i.e. by SS) to be used by the UE as contact address in further SIP signalling of the dialog NOTE: in general this URI shall be different than the one in px_CalleeUri	charstring	"sip:User-B-Contact@3gpp.org"	
px_CiphAlgo_Def	Ciphering Algorithm	CiphAlgo	nociph	enumerated type: des_edecbc, aes_cbc or nociph
px_DNS_DomainName	DNS server fully qualified domain name (FQDN) Editors note: FFS	charstring	"dnserver.3gpp.org"	
px_HomeDomainName	Home Domain Name. Applicable when using an ISIM:same value as EF _{DOMAIN} . (derived from the IMSI otherwise)	charstring	As defined in TS 34.229-1 [5], Annex E	
px_IMS_HomeDomainName_Refreshed	used in 8.15	charstring	"refreshed3gpp.org"	
px_IMS_Private_UserId_Refreshed	used in 8.15	charstring	"privateuser@refreshed3gpp.org"	
px_IMS_PublicUserIdentity1_Refreshed	used in 8.15	charstring	"sip:PublicId1@refreshed3gpp.org"	
px_IPSecAlgorithm	Integrity Algorithm	IntAlgo	hmac_md5_96	enumerated type; hmac_md5_96, hmac_sha_1_96
px_P_CSCF_IPAddr	IP address of P-CSCF (in v4 or v6 format) Editors note: FFS	IPAddr	"10.122.11.33"	
px_Pcscf	P-CSCF fully qualified domain name that resolves to the IP address of SS Editors note: It seems not to be necessary to define this as a PIXIT	charstring	"pcscf.3gpp.org"	
px_Pcscf_Emg	P-CSCF fully qualified domain name that resolves to the IP address of SS for emergency calls Editors note: FFS	charstring	"pcscfemg.3gpp.org"	
px_PeerUE_IPAddr	IP address of peer UE	IPAddr	"10.122.11.55"	

Parameter name	Description	Type	Default value	Supported value
	(in v4 or v6 format)			
px_Private_UserId	Private User Identity. Applicable when using an ISIM:same value as EF _{IMPI} . (derived from the IMSI otherwise)	charstring	As defined in TS 34.229-1 [5], Annex E	
px_PublicUserIdentity1	Public User Identity. It is set to the same value as the first record in EF _{IMPU} .	charstring	As defined in TS 34.229-1 [5], Annex E	
px_PublicUserIdentity2	It is set to the same value as the second record in EF _{IMPU} .	Charstring	As defined in TS 34.229-1 [5], Annex E	
px_PublicUserIdentity3	It is set to the same value as the third record in EF _{IMPU} .	Charstring	As defined in TS 34.229-1 [5], Annex E	
px_Scscf	S-CSCF fully qualified domain name that does not resolve to the IP address of SS Editors note: It seems not to be necessary to define this as a PIXIT	charstring	"scscf@3gpp.org"	
px_SMS_SMSC_InternationalNumber	international number of the SMSC: It is set to the same value as used in EF _{PSISMSC} if the EF is present on the ISIM (or the USIM) Otherwise it is set to the same value as EF _{SMSP}	charstring	As defined in Annex E of TS 34.229-1 [5]	
px_UEwithISIM	true UE has ISIM false UE has USIM only	boolean	true	
px_UEwithSIM	UE has a SIM inserted	boolean	false	
px_XCAPServerAddress	XCAP Server Address	charstring	"10.122.11.26"	

B.2 MMI Commands

In addition to the MMI commands defined in TS 36.523-3 clause 5 there are further MMI commands for IMS:

Table B.2.1-1: MMI commands

Command	Parameters	
	Name	Value
"DEREGISTER"	(none)	
"INITIATE_VIDEO_CALL"	"Uri"	<Callee's URI>
"ACCEPT_MTSI_TEXT"	(none)	
"ACTIVATE_MESSAGE_WAIT_INDICATION"	(none)	
"TRIGGER_SMS"	(none)	
"TRIGGER_2ND_IMPU"	(none)	
"TRIGGER_3RD_IMPU"	(none)	
"REFRESH"	"Uri"	<Callee's URI>
"REMOVE_VIDEO_CALL"	(none)	

Annex C: Void

Annex D: Void

Annex E (informative): TTCN3 style guide for 3GPP IMS ATS

For IMS conformance tests, the style guide of 36.523-3[30], Annex B shall be applied

Annex F (informative): BNF Message Definitions

The BNF definitions required for the ATS are defined in the following RFCs:

3261, 3262, 3265, 3311, 3313, 3323, 3325, 3326, 3327, 3329, 3428, 3455, 3515, 3608, 3840, 3841, 3891, 3892, 3903, 3911, 4028.

Annex G (Normative): SIP Type Definitions and XSD References

The XSD references listed in this Annex are imported in the Test Suite.

Common Definitions

XML Schema	RFC	Name space	Modifications
reginfo	RFC 3680 [24]	urn:ietf:params:xml:ns:reginfo	"http://www.w3.org/2001/03/xml.xsd" to be replaced by 'xml.xsd'
conference-info	RFC 4575 [45]	urn:ietf:params:xml:ns:conference-info	
gruuinfo	RFC 5628 [46]	urn:ietf:params:xml:ns:gruuinfo	
AlternativeService	TS 24.229 [11] Table 7.6.1	NoTargetNamespace	
pdfif	RFC 3863 [47]	urn_ietf_params_xml_ns_pdfif	definitions modified according to errata id 1606
pdfif_geopriv10	RFC 4119 [44]	urn_ietf_params_xml_ns_pdfif_geopriv10	NOTE: RFC's errata has no impact on definitions
pdfif_geopriv10_basicPolicy	RFC 4119 [44]	urn_ietf_params_xml_ns_pdfif_geopriv10_basicPolicy	NOTE: RFC's errata has no impact on definitions
pdfif_geopriv10_civicLoc	RFC 4119 [44]	urn_ietf_params_xml_ns_pdfif_geopriv10_civicLoc	NOTE: RFC's errata has no impact on definitions

XCAP specific definitions

XML Schema	RFC or other spec	Name space
24604	TS 24.604 [40]	http_uri_etsi_org_ngn_params_xml_simservs_xcap
OIP-OIR	TS 24.607 [41]	http_uri_etsi_org_ngn_params_xml_simservs_xcap
TIP-TIR R2	TS 24.608 [42]	http_uri_etsi_org_ngn_params_xml_simservs_xcap
24611	TS 24.611 [43]	http_uri_etsi_org_ngn_params_xml_simservs_xcap
XCAP	TS 24.623 [36]	http_uri_etsi_org_ngn_params_xml_simservs_xcap
xm-commonPolicy-V1_0	http://technical.openmobilealliance.org/tech/profiles/xm-commonPolicy-v1_0.xsd	urn_oma_xml_xm-common_policy
common-policy	RFC 4745 [48]	urn_ietf_params_xml_ns_common_policy

Additionally the Test Suite imports the following modules of ETSI's LibSip (the modules are store in ETSI's SIP library repository; FFS):

Module	Revision
LibSip_SDPTypes	FFS
LibSip_SimpleMsgSummaryTypes	FFS
LibSip_SIPTypesAndValues	FFS

Annex H (informative): TTCN-3 Definitions of Common Interfaces

The multi-testers model according to clause 5 provides interfaces which can be re-used by implementations of the IP-CAN test model according to TS 34.229-4 [50].

NOTE: Common type definitions are according to annex D of TS 36.523-3 [30].

H.1 IMS_PTC_CoordMsg

IMS_TestProcedure_Type

TTCN-3 Enumerated Type	
Name	IMS_TestProcedure_Type
Comment	
IPCAN_InitialRegistration	EUTRA/EPS signalling acc. to 36.508 cl. 4.5.2.3 without RRC Connection Release at the end of the procedure NOTE: As working assumption the UE does IMS REGISTRATION automatically after RRC/NAS registration; if that is not the case the IMS PTC may trigger release of the connection after some time and initiate manual IMS registration (FFS)
IPCAN_EmergencyCall_NormalService	EUTRA/EPS signalling acc. to 36.508 cl. 4.5A.4.3
IPCAN_EmergencyCall_LimitedService	EUTRA/EPS signalling acc. to 36.508 cl. 4.5A.5.3
IPCAN_MO_SpeechCall	EUTRA/EPS signalling acc. to 36.508 cl. 4.5A.6.3
IPCAN_MT_SpeechCall	EUTRA/EPS signalling acc. to 36.508 cl. 4.5A.7.3
IPCAN_MO_VideoCall	EUTRA/EPS signalling acc. to 36.508 cl. 4.5A.8.3
IPCAN_MT_VideoCall	EUTRA/EPS signalling acc. to 36.508 cl. 4.5A.9.3
IPCAN_MO_IMS_Signalling	EUTRA/EPS signalling acc. to 36.508 cl. 4.5.3.3 with $m = n = 0$; used e.g. for MT SMS test case 18.2
IPCAN_MT_IMS_Signalling	EUTRA/EPS signalling acc. to 36.508 cl. 4.5.3.3 Steps 3 to 9 with $m = n = 0$; used e.g. for MT SMS test case 18.1
IPCAN_XCAP_Signalling	EUTRA/EPS signalling acc. to 36.508 cl. 4.5A.14

IMS_TestConfiguration_Type

TTCN-3 Enumerated Type	
Name	IMS_TestConfiguration_Type
Comment	
IPCAN_SignallingOnly	EUTRA: default DRB is used only
IPCAN_SpeechCall	EUTRA: one dedicated UM bearer; for normal speech calls and emergency call for limited services
IPCAN_VideoCall	EUTRA: two dedicated UM bearers
IPCAN_EmergencyCall	EUTRA: second default bearer (AM) and one dedicated UM bearer
IPCAN_XCAP	EUTRA: second default bearer (AM) for second PDN used for XCAP signalling

IMS_CellConfiguration_Type

TTCN-3 Enumerated Type	
Name	IMS_CellConfiguration_Type
Comment	
SIB2_Normal	to change cell configuration back to normal configuration
SIB2_TC_12_18	SIB2 configuration acc. to test case 12.18
SIB2_TC_12_19	SIB2 configuration acc. to test case 12.19
SIB2_TC_12_20	SIB2 configuration acc. to test case 12.20
IPCAN_UpdateUELocationInformation	EUTRA: set UELocationInformation acc. to 36.509

IPCAN_INFO_Type

TTCN-3 Record Type			
Name	IPCAN_INFO_Type		
Comment			
RanType	IPCAN_RAN_Type	opt	
UE_Release	integer	opt	
AuthResLength	integer	opt	

IMS_IPCAN_CommandName_Type

TTCN-3 Enumerated Type	
Name	IMS_IPCAN_CommandName_Type
Comment	
IPCAN_INIT	trigger the IPCAN_PTC to create a cell and do further appropriate initialisation; which RAN technology to be use is decided by the IPCAN_PTC based on PIXITs; as test procedure shall be specified which procedure is used during the test body to know which DRBs need to be pre-configured; IPCAN returns response indicating the RAN type
IPCAN_CONFIG	trigger the IPCAN_PTC to apply test case specific change of the cell configuration as e.g. SIB2 for cell barring
IPCAN_STARTPROCEDURE	trigger the IPCAN to expect (MO) or page (MT) the UE to establish an RRC connection; depending on the connection type triggers may need to be sent from IPCAN to IMS or from IMS to IPCAN to synchronise establishment of dedicated DRBs (EUTRA) or secondary PDP contexts (UTRAN)
IPCAN_ENDPROCEDURE	trigger RRC connection release by the IPCAN_PTC; for UTRAN it is up to IPCAN and SS implementation to cope with possible/necessary release of (secondary) PDP context; a trigger is shall be sent from IPCAN to IMS to indicate when RRC connection is released
IPCAN_RELEASE	Detach UE and release cell (postamble); a trigger is shall be sent from IPCAN to IMS to indicate when IPCAN is released
IPCAN_QUERY	query information from the IPCAN_PTC

IMS_IPCAN_Command_Type

TTCN-3 Record Type			
Name	IMS_IPCAN_Command_Type		
Comment	Messages IMS_PTC -> IPCAN		
Name	IMS_IPCAN_CommandName_Type		
TestConfiguration	IMS_TestConfiguration_Type	opt	
TestProcedure	IMS_TestProcedure_Type	opt	
CellConfiguration	IMS_CellConfiguration_Type	opt	used for IPCAN_CONFIG to allow test case specific initialisation of the EUTRA cell info

IMS_IPCAN_ResponseName_Type

TTCN-3 Enumerated Type	
Name	IMS_IPCAN_ResponseName_Type
Comment	
IPCAN_INIT	response for INIT command: carries the RAN type as used by the IPCAN PTC; the RAN type depends on PIXIT settings: 34.229 model: px_RANTech 36.523 model: EUTRA_FDD or EUTRA_TDD depending on px_ePrimaryFrequencyBand (px_ePrimaryFrequencyBand < 33 => FDD)
IPCAN_QUERY	

IPCAN_IMS_Response_Type

TTCN-3 Record Type			
Name	IPCAN_IMS_Response_Type		
Comment			
Name	IMS_IPCAN_ResponseName_Type		
IpcanInfo	IPCAN_INFO_Type	opt	

IMS_IPCAN_Coordination_MSG

TTCN-3 Union Type		
Name	IMS_IPCAN_Coordination_MSG	
Comment		
TriggerEvent	Null_Type	any trigger of confirmation
AbortEvent	Null_Type	sent instead of TriggerEvent if procedure shall be aborted
IMS_IPCAN_Command	IMS_IPCAN_Command_Type	IMS -> IPCAN: command to be done at IPCAN
IPCAN_IMS_Response	IPCAN_IMS_Response_Type	IMS <- IPCAN: response for previous command
ProtocolConfigOptions	NAS_ProtocolConfigOptions_Type	IMS <-> IPCAN: PCOs to be used in NAS signalling

IMS_IPCAN_CO_ORD_PORT

TTCN-3 Port Type		
Name	IMS_IPCAN_CO_ORD_PORT	
Comment		
out	IMS_IPCAN_Coordination_MSG	
in	IMS_IPCAN_Coordination_MSG	

IMS_IMS_Coordination_MSG

TTCN-3 Union Type		
Name	IMS_IMS_Coordination_MSG	
Comment		
TriggerEvent	Null_Type	

IMS_IMS_CO_ORD_PORT

TTCN-3 Port Type		
Name	IMS_IMS_CO_ORD_PORT	
Comment		
out	IMS_IMS_Coordination_MSG	
in	IMS_IMS_Coordination_MSG	

H.2 IMS_ASP_TypeDefs

IMS_ASP_TypeDefs: Basic Type Definitions

TTCN-3 Basic Types		
IMS_Request_Type	RequestUnion	Alias for 'RequestUnion' as defined in LibSip_SIPTypesAndValues
IMS_Response_Type	Response	Alias for 'Response' as defined in LibSip_SIPTypesAndValues
IMS_PortsAndSecurityConfigCnf_Type	Null_Type	SPIs and protected ports are fully controlled by the IMS PTC => it is not necessary anymore to return IMS_ProtectedPorts_Type, IMS_SPIs_Type to the IMS PTC

IMS_ProtectedUnprotected_Type

TTCN-3 Enumerated Type	
Name	IMS_ProtectedUnprotected_Type
Comment	
protected	
unprotected	

IMS_RoutingInfo_Type

TTCN-3 Record Type			
Name	IMS_RoutingInfo_Type		
Comment			
Protocol	InternetProtocol_Type		UDP or TCP
Security	IMS_ProtectedUnprotected_Type	opt	protected or unprotected (in DL omit when IP PTC shall decide what to do)
UE_Address	IP_AddrInfo_Type	opt	sent by the IP PTC when there is an initial request on unprotected connection
NW_Address	IP_AddrInfo_Type	opt	sent by the IP PTC when there is an initial request on unprotected connection

IMS_DATA_REQ

TTCN-3 Record Type			
Name	IMS_DATA_REQ		
Comment			
RoutingInfo	IMS_RoutingInfo_Type		
Request	IMS_Request_Type		

IMS_DATA_RSP

TTCN-3 Record Type			
Name	IMS_DATA_RSP		
Comment			
RoutingInfo	IMS_RoutingInfo_Type		
Response	IMS_Response_Type		

IMS_ProtectedPorts_Type

TTCN-3 Record Type			
Name	IMS_ProtectedPorts_Type		
Comment			
Port_us	PortNumber_Type		UE side: Server
Port_uc	PortNumber_Type		UE side: Client
Port_ps	PortNumber_Type		network side: Server
Port_pc	PortNumber_Type		network side: Client

IMS_SPIs_Type

TTCN-3 Record Type			
Name	IMS_SPIs_Type		
Comment			
SPI_us	IPsec_SPI_Type		SPI at UE side: assigned by the UE
SPI_uc	IPsec_SPI_Type		SPI at UE side: assigned by the UE
SPI_ps	IPsec_SPI_Type	opt	SPI at network side: to be assigned by TTCN
SPI_pc	IPsec_SPI_Type	opt	SPI at network side: to be assigned by TTCN

IMS_SecurityInfo_Type

TTCN-3 Record Type			
Name	IMS_SecurityInfo_Type		
Comment			
ProtectedPorts	IMS_ProtectedPorts_Type		
SPIs	IMS_SPIs_Type		
IntegrityAlgorithm	IPsec_IntegrityAlgorithm_Type		
CipheringAlgorithm	IPsec_CipheringAlgorithm_Type		

IMS_RegistrationInfo_Type

TTCN-3 Record Type			
Name	IMS_RegistrationInfo_Type		
Comment			
NW_Address	IP_AddrInfo_Type		network address of the chosen IMS server (e.g. IPv4, IPv6)
UE_Address	IP_AddrInfo_Type		UE address as used for security protected connections
SecurityInfo	IMS_SecurityInfo_Type	opt	omit in case of GIBA

IMS_PortsAndSecurityConfigReq_Type

TTCN-3 Record Type			
Name	IMS_PortsAndSecurityConfigReq_Type		
Comment			
UnprotectedPort_us	PortNumber_Type	opt	5060 per default
RegistrationInfo	IMS_RegistrationInfo_Type		

IMS_CONFIG_REQ

TTCN-3 Union Type	
Name	IMS_CONFIG_REQ
Comment	
InstallKey	IPsec_SecurityKeys_Type
PortsAndSecurityConfig	IMS_PortsAndSecurityConfigReq_Type
SecurityRelease	IMS_SecurityInfo_Type
CloseTCP	Null_Type

IMS_CONFIG_CNF

TTCN-3 Union Type	
Name	IMS_CONFIG_CNF
Comment	
InstallKey	Null_Type
PortsAndSecurityConfig	IMS_PortsAndSecurityConfigCnf_Type
SecurityRelease	Null_Type
CloseTCP	Null_Type

IMS_IP_CTRL_PORT

TTCN-3 Port Type	
Name	IMS_IP_CTRL_PORT
Comment	Control port at the IMS PTC to configure IP for IMS
out	IMS_CONFIG_REQ
in	IMS_CONFIG_CNF

IP_IMS_CTRL_PORT

TTCN-3 Port Type	
Name	IP_IMS_CTRL_PORT
Comment	Control port at the IP PTC to get configuration from IMS
out	IMS_CONFIG_CNF
in	IMS_CONFIG_REQ

IMS_IP_CLIENT_PORT

TTCN-3 Port Type	
Name	IMS_IP_CLIENT_PORT
Comment	IMS client: send requests, receive response
out	IMS_DATA_REQ
in	IMS_DATA_RSP

IP_IMS_CLIENT_PORT

TTCN-3 Port Type	
Name	IP_IMS_CLIENT_PORT
Comment	counter part for the IMS client at the IP PTC: receive requests, send response
out	IMS_DATA_RSP
in	IMS_DATA_REQ

IMS_IP_SERVER_PORT

TTCN-3 Port Type	
Name	IMS_IP_SERVER_PORT
Comment	IMS server: send response, receive requests
out	IMS_DATA_RSP
in	IMS_DATA_REQ

IP_IMS_SERVER_PORT

TTCN-3 Port Type	
Name	IP_IMS_SERVER_PORT
Comment	counter part for the IMS server at the IP PTC: receive response, send requests
out	IMS_DATA_REQ
in	IMS_DATA_RSP

H.3

H.4 References to TTCN-3

References to TTCN-3		
IMS_PTC_CoordMsg	IMS/IMS_PTC_CoordMsg.ttcn	Rev 9788
IMS_ASP_TypeDefs	IMS/IMS_ASP_TypeDefs.ttcn	Rev 10435
IMS_UpperTester	IMS/IMS_UpperTester.ttcn	Rev 10148

Annex I (informative): Change history

Meeting	TSG doc	CR	Rev	Subject	Cat	Old vers	New vers	WG doc
RP-31	RP-060054	-	-	Update to version 1.0.0 and present to RAN#31 for information	-	-	1.0.0	R5-060513
RP-34	RP-060664	-	-	Present version 1.3.0 to RAN#34 for information	-	-	1.3.0	R5-063500
RP-35	RP-070010	-	-	Presented as version 2.0.0 for approval to go under revision control	-	-	2.0.0	R5-070456
-	-	-	-	Upgraded to version 5.0.0 by the 3GPP support	-	-	5.0.0	-
RP-36	RP-070352	0001	-	Addition of IMS-CC test case 8.6 to IMS_CC ATS V1.3.0	F	5.0.0	5.1.0	R5s070101
RP-36	RP-070353	0002	-	CR to 34.229-3: Add new verified and e-mail agreed TTCN test cases in the TC lists in 34.229-3 (prose), Annex A	F	5.0.0	5.1.0	-
RP-37	RP-070594	0003	-	Extension to TTCN ASP DeactivatePDPCContextReq	F	5.1.0	5.2.0	R5-072509
RP-37	RP-070594	0004	-	IMS CC / PIXIT parameter px_CellId	F	5.1.0	5.2.0	R5-072546
RP-38	RP-070870	0007		Addition of IMS-CC test case 8.5 to IMS_CC ATS V5.1.0	B	5.2.0	5.3.0	R5s070489
RP-38	RP-070870	0008		Addition of IMS-CC test case 8.7 to IMS_CC ATS V5.3.0	B	5.2.0	5.3.0	R5s070259
RP-38	RP-070870	0009		Addition of IMS-CC test case 9.1 to IMS_CC ATS V5.3.0	B	5.2.0	5.3.0	R5s070261
RP-38	RP-070889	0010		CR to 34.229-3: Add new verified and e-mail agreed TTCN test cases in the TC lists in 34.229-3 (prose), Annex A	F	5.2.0	5.3.0	-
RP-38	RP-070869	0006		Production of 34.229-3 pointer version in Rel-5 pointing to Rel-6 version	F	5.2.0	5.3.0	R5-073439
RP-38	RP-070869	0005		Addition of an MMI command	F	5.2.0	6.0.0	R5-073046
RP-39	RP-080098	0011		Update of MMI command strings	F	6.0.0	6.1.0	R5-080041
RP-39	RP-080089	0012		CR to 34.229-3: Add new verified and e-mail agreed TTCN test cases in the TC lists in 34.229-3 (prose), Annex A	F	6.0.0	6.1.0	-
RP-39	RP-080094	0013		Addition of IMS-CC test case 7.2 to IMS_CC ATS V5.3.0	B	6.0.0	6.1.0	R5s070535
RP-39	RP-080094	0014		Addition of IMS-CC test case 10.1 to IMS_CC ATS V5.1.0	B	6.0.0	6.1.0	R5s070549
RP-39	RP-080094	0015		Addition of IMS-CC test case 8.3 to IMS_CC ATS V5.1.0	B	6.0.0	6.1.0	R5s070545
RP-39	RP-080094	0016		Addition of IMS-CC test case 8.2 to IMS_CC ATS V5.1.0	B	6.0.0	6.1.0	R5s070543
RP-39	RP-080094	0017		Addition of IMS-CC test case 7.6 to IMS_CC ATS V5.1.0	B	6.0.0	6.1.0	R5s070539
RP-39	RP-080094	0018		Addition of IMS-CC test case 7.4 to IMS_CC ATS V5.1.0	B	6.0.0	6.1.0	R5s070537
RP-39	RP-080094	0019		Addition of IMS-CC test case 11.1 to IMS_CC ATS V5.1.0	B	6.0.0	6.1.0	R5s070551
RP-39	RP-080094	0020		Addition of IMS-CC test case 14.1 to IMS_CC ATS V5.1.0	B	6.0.0	6.1.0	R5s070555
RP-39	RP-080094	0021		Addition of IMS-CC test case 13.1 to IMS_CC ATS V5.1.0	B	6.0.0	6.1.0	R5s070553
RP-39	RP-080094	0022		Addition of IMS-CC test case 8.4 to IMS_CC ATS V5.1.0	B	6.0.0	6.1.0	R5s070547
RP-39	RP-080094	0023		Addition of IMS-CC test case 8.1 to IMS_CC ATS V5.1.0	B	6.0.0	6.1.0	R5s070541
RP-39	RP-080094	0024		Addition of IMS-CC test case 7.1 to IMS_CC ATS V5.1.0	B	6.0.0	6.1.0	R5s070491
RP-39	RP-080094	0025		Common corrections to IMS-CC test cases	F	6.0.0	6.1.0	R5s070534
RP-40	RP-080369	0027		Correction to regular expressions in IMS	F	6.1.0	7.0.0	R5s080036
RP-40	RP-080369	0028		IMS ATS / handling of P-Access-Network-Info header over non secure ports	F	6.1.0	7.0.0	R5s080063
RP-40	RP-080369	0029		IMS ATS / test case 9.1 / handling of authorization header in Register messages	F	6.1.0	7.0.0	R5s080085
RP-40	RP-080376	0030		Extend test model supporting XCAP test	F	6.1.0	7.0.0	R5-081036
RP-41	RP-080654	0031		CR to 34.229-3: Add new verified and e-mail agreed TTCN test cases in the TC lists in 34.229-3 (prose), Annex A	F	7.0.0	7.1.0	-
RP-41	RP-080615	0032		Addition of IMS-CC test case 9.2 to IMS_CC ATS v.7.0.0	F	7.0.0	7.1.0	R5s080115
RP-41	RP-080615	0033		Addition of IMS-CC test case 7.3 to IMS_CC ATS	F	7.0.0	7.1.0	R5s080114

Meeting	TSG doc	CR	Rev	Subject	Cat	Old vers	New vers	WG doc
				v.7.0.0				
RP-41	RP-080615	0034		Implementation of IPCanCtl code as a parallel test component	F	7.0.0	7.1.0	R5s080138
RP-41	RP-080615	0035		Addition of IMS-CC test case 8.9 to IMS_CC ATS v.6.2.0	F	7.0.0	7.1.0	R5s080145
RP-41	RP-080615	0036		Addition of IMS-CC test case 8.8 to IMS_CC ATS v.6.2.0	F	7.0.0	7.1.0	R5s080143
RP-41	RP-080615	0037		Addition of IMS-CC test case 7.5 to IMS_CC ATS	F	7.0.0	7.1.0	R5s080151
RP-41	RP-080740	0038		Update of TS 34.229-3 from Rel-6 to Rel-7	F	7.1.0	7.2.0	R5-083065
RP-42	RP-080959	0039		Correction of HW Type and HW Length fields in DHCP response messages	F	7.1.0	7.2.0	R5s080171
RP-42	RP-080959	0040		Minor correction of Route header template in the initial Register message	F	7.1.0	7.2.0	R5s080168
RP-43	RP-090210	0041		Update of TS 34.229-3 from Rel-7 to Rel-8	F	7.2.0	8.0.0	R5-090765
RP-43	RP-090210	0042		IMS CC ATS / Improvement: Stopping test case execution once a PTC fails	F	8.0.0	8.1.0	R5s090019
RP-43	RP-090210	0043		IMS CC ATS / Handling of non-default port number in the Contact Header	F	8.0.0	8.1.0	R5s090018
RP-43	RP-090210	0044		IMS CC ATS / Handling of Contact Header	F	8.0.0	8.1.0	R5s090005
RP-43	RP-090210	0045		IMS CC / Minor corrections on test 11.2 (re-authentication)	F	8.0.0	8.1.0	R5s090004
RP-43	RP-090210	0046		IMS CC / Addition of test case 11.2 to the IMS ATS	F	8.0.0	8.1.0	R5s080313
RP-43	RP-090210	0047		IMS CC test model / Addition of new ASP to reconfigure IP Layer	F	8.0.0	8.1.0	R5-090032
RP-43	RP-090210	0048		Removal of an unused pixit and other routine updates	F	8.0.0	8.1.0	R5-090056
RP-46	RP-091156	0049	-	CR to 34.229-3 (prose) update to v820	F	8.1.0	8.2.0	-
RP-47	RP-100146	0050	-	CR to 34.229-3 (prose) update to v830	F	8.2.0	8.3.0	-
RP-47	RP-100155	0051	-	Correction of IMS test model for XCAP-based SS test	F	8.2.0	8.3.0	R5-100087
RP-47	RP-100140	0052	-	Add bearer information for E-UTRA	F	8.2.0	8.3.0	R5-100414
RP-48	RP-100514	0053	-	CR to 34.229-3 (prose) update to v840	F	8.3.0	8.4.0	-
RP-48	RP-100511	0054	-	Update IMS test model	F	8.3.0	8.4.0	R5-103382
RP-50	RP-101146	0055	-	Routine maintenance of TS 34.229-3	F	8.4.0	8.5.0	R5-106088
RP-50	RP-101150	0056	-	CR to 34.229-3 update to v850	F	8.4.0	8.5.0	-
RP-51	RP-110165	0057	-	Mapping of some PIXIT parameters to ISIM EFs – 3 IMPU	F	8.5.0	8.6.0	R5-110694
RP-51	RP-110169	0058	-	CR to 34.229-3 (prose) update to v860	F	8.5.0	8.6.0	-
RP-52	RP-110651	0059	-	Removal of technical content in 34.229-3 v8.6.0 and substitution with pointer to the next Release	F	8.6.0	8.7.0	R5-112246
RP-52	RP-110651	0060	-	Routine maintenance	F	8.6.0	9.0.0	R5-112648
RP-52	RP-110655	0061	-	CR to 34.229-3 (prose) update to v870	F	8.6.0	9.0.0	-
RP-53	RP-111160	0062	-	CR to 34.229-3 (prose) update to v910	F	9.0.0	9.1.0	-
RP-54	RP-111584	0063	-	Routine maintenance and updates for IMS ASP	F	9.1.0	9.2.0	R5-115670
RP-55	RP-120187	0064	-	CR to 34.229-3 (prose) update to v930	F	9.2.0	9.3.0	-
RP-56	RP-120649	0065	-	Routine maintenance and updates	F	9.3.0	9.4.0	R5-121090
RP-56	RP-120802	0066	-	Correction to IMS CC test cases / IPv6 address handling	F	9.3.0	9.4.0	R5s120108
RP-57	RP-121103	0067	-	34229-3: Routine maintenance and updates	F	9.4.0	9.5.0	R5-123085
RP-57	RP-121221	0068	-	TTCN IMS correction	F	9.4.0	9.5.0	R5s120530
RP-57	RP-121221	0069	-	Addition of GCF WI-031 IMS test case 8.10	F	9.4.0	9.5.0	R5s120537
RP-57	RP-121221	0070	-	Addition of GCF WI-031 IMS test case 8.12	F	9.4.0	9.5.0	R5s120539
RP-57	RP-121221	0071	-	Addition of GCF WI-031 IMS test case 8.13	F	9.4.0	9.5.0	R5s120541
RP-57	RP-121221	0072	-	Addition of GCF WI-128 IMS test case 18.1	F	9.4.0	9.5.0	R5s120543
RP-57	RP-121221	0073	-	Addition of GCF WI-128 IMS test case 18.2	F	9.4.0	9.5.0	R5s120545
RP-57	RP-121221	0074	-	Addition of GCF WI-103 IMS test case 16.1	F	9.4.0	9.5.0	R5s120547
RP-57	RP-121221	0075	-	Addition of GCF WI-103 IMS test case 16.2	F	9.4.0	9.5.0	R5s120549
RP-57	RP-121106	0076	-	CR to 34.229-3: Add new verified and e-mail agreed TTCN test cases in the TC lists in 34.229-3 (prose), Annex A	F	9.4.0	9.5.0	-
RP-58	RP-121664	0077	-	34229-3: Routine maintenance and updates	F	9.5.0	9.6.0	R5-125120
RP-58	RP-121669	0078	-	Addition of GCF WI-103 IMS test case 12.12	B	9.5.0	9.6.0	R5s120605
RP-58	RP-121669	0079	-	Addition of GCF WI-103 IMS test case 12.13	B	9.5.0	9.6.0	R5s120607
RP-58	RP-121669	0080	-	Addition of GCF WI-103 IMS test case 15.11	B	9.5.0	9.6.0	R5s120609
RP-58	RP-121669	0081	-	IMS TTCN correction	F	9.5.0	9.6.0	R5s120729
RP-58	RP-121669	0082	-	Addition of GCF WI-103 IMS test case 15.8	B	9.5.0	9.6.0	R5s120730
RP-58	RP-121669	0083	-	Addition of GCF WI-103 IMS test case 15.12	B	9.5.0	9.6.0	R5s120732
RP-58	RP-121669	0084	-	Addition of GCF WI-103 IMS test case 15.27	B	9.5.0	9.6.0	R5s120733
RP-58	RP-121669	0085	-	Addition of GCF WI-103 IMS test case 15.28	B	9.5.0	9.6.0	R5s120736
RP-58	RP-121668	0086	-	CR to 34.229-3: Add new verified and e-mail agreed TTCN test cases in the TC lists in 34.229-3 (prose), Annex A	F	9.5.0	9.6.0	-
RP-59	RP-130145	0087	-	34229-3: Routine maintenance and updates	F	9.6.0	9.7.0	R5-130198
RP-59	RP-130150	0088	-	Re-verification of IMS Registration test case 8.10 over	F	9.6.0	9.7.0	R5s120858

Meeting	TSG doc	CR	Rev	Subject	Cat	Old vers	New vers	WG doc
				LTE with 36.523-3 test model				
RP-59	RP-130150	0089	-	Corrections for IMS test cases with 34.229-3 test model	F	9.6.0	9.7.0	R5s120907
RP-59	RP-130150	0090	-	Re-verification of IMS Registration test case 8.4 over LTE with new 34.229-3 test model	F	9.6.0	9.7.0	R5s120945
RP-59	RP-130150	0091	-	Re-verification of IMS Authentication test case 9.1 over LTE with the new 34.229-3 test model	F	9.6.0	9.7.0	R5s120947
RP-59	RP-130150	0092	-	Corrections to IMS_36523_IWD_12wk48 test suite	F	9.6.0	9.7.0	R5s130011
RP-59	RP-130150	0093	-	Corrections for IMS TC 8.1 regarding IPv6 privacy	F	9.6.0	9.7.0	R5s130049
RP-59	RP-130149	0094	-	CR to 34.229-3 (prose) update to v970	F	9.6.0	9.7.0	-
RP-60	RP-130611	0095	-	34229-3: Routine maintenance and updates	F	9.7.0	9.8.0	R5-131140
RP-60	RP-130617	0096	-	Corrections to feature parameter in MT call invitation	F	9.7.0	9.8.0	R5s130109
RP-60	RP-130617	0097	-	Re-verification of IMS Registration (IPSec) test case 8.1 over LTE with 36.523-3 test model	F	9.7.0	9.8.0	R5s130133
RP-60	RP-130617	0098	-	Re-verification of IMS test case 8.3 over LTE with 36.523-3 test model	F	9.7.0	9.8.0	R5s130181
RP-60	RP-130617	0099	-	Re-verification of IMS SMS test case 18.2 over LTE with 36.523-3 test model	F	9.7.0	9.8.0	R5s130183
RP-60	RP-130617	0100	-	Corrections for IMS TC 8.1	F	9.7.0	9.8.0	R5s130187
RP-60	RP-130617	0101	-	Re-verification of IMS Registration test case 8.2 over LTE with 34.229-3 test model	F	9.7.0	9.8.0	R5s130233
RP-60	RP-130617	0102	-	Re-verification of IMS SMS test case 18.1 over LTE with 34.229-3 test model	F	9.7.0	9.8.0	R5s130235
RP-60	RP-130617	0103	-	Correction to SIP template cr_FromWithTag	F	9.7.0	9.8.0	R5s130256
RP-60	RP-130617	0104	-	Re-verification of IMS Authentication test case 9.2 over LTE with 34.229-3 test model	F	9.7.0	9.8.0	R5s130264
RP-60	RP-130617	0105	-	Re-verification of IMS Notification test case 11.2 over LTE with 34.229-3 test model	F	9.7.0	9.8.0	R5s130266
RP-60	RP-130617	0106	-	Corrections for IMS Registration TC 8.3 over LTE with 34.229-3 test model	F	9.7.0	9.8.0	R5s130274
RP-60	RP-130617	0107	-	Re-verification of IMS Subscription test case 10.1 over LTE with 34.229-3 test model	F	9.7.0	9.8.0	R5s130294
RP-60	RP-130617	0108	-	Re-verification of IMS Registration test case 11.1 over LTE with 34.229-3 test model	F	9.7.0	9.8.0	R5s130296
RP-60	RP-130617	0109	-	Re-verification of IMS Call Control test case 12.12 over LTE with 36.523-3 test model	F	9.7.0	9.8.0	R5s130333
RP-61	RP-131107	0111	-	Correction to EPS ATTACH procedure to enable IMS Registration via NAS signalling	F	9.8.0	9.9.0	R5s130383
RP-61	RP-131107	0112	-	Correction to IMS test cases 8.1, 8.2, 8.3 and 8.4	F	9.8.0	9.9.0	R5s130454
RP-61	RP-131107	0113	-	Correction to encoding rules to be used for Reginfo_Type	F	9.8.0	9.9.0	R5s130474
RP-61	RP-131107	0114	-	Corrections for IMS call control test case 12.12	F	9.8.0	9.9.0	R5s130497
RP-61	RP-131107	0115	-	Addition of GCF WI-154/ee1 IMS Emergency Call over EPS test case 19.1.2 (using TS 36.523-3 test model)	B	9.8.0	9.9.0	R5s130508
RP-61	RP-131107	0116	-	Re-verification for IMS TC 12.13 over LTE with 34.229-3 test model	F	9.8.0	9.9.0	R5s130510
RP-61	RP-131107	0117	-	Corrections to GCF WI-128 SMS over IMS Testcase 18.1	F	9.8.0	9.9.0	R5s130514
RP-61	RP-131107	0118	-	Correction of IMS test case 9.2 over LTE with 34.229-3 test model	F	9.8.0	9.9.0	R5s130573

Meeting	TSG doc	CR	Rev	Subject	Cat	Old vers	New vers	WG doc
RP-61	RP-131107	0119	-	Verification for IMS test case 12.2 over LTE with 34.229-1 test model	B	9.8.0	9.9.0	R5s130580
RP-61	RP-131107	0120	-	Correction of IMS test case 12.12 over LTE with 34.229-3 test model	F	9.8.0	9.9.0	R5s130586
RP-61	RP-131106	0121	-	CR to 34.229-3: Add new verified and e-mail agreed TTCN test cases in the TC lists in 34.229-3 (prose), Annex A	F	9.8.0	9.9.0	RP-131106
RP-61	RP-131100	0110	-	34229-3: Routine maintenance and updates	F	9.9.0	10.0.0	R5-133632
RP-62	RP-131875	0122	-	Splitting 34.229-3	F	10.0.0	10.1.0	R5-134070
RP-62	RP-132006	0123	-	34229-3: Routine maintenance and updates for multi-testers model	F	10.0.0	10.1.0	R5-134290
RP-62	RP-131868	0125	-	Regression CR for IMS registration procedure in ATS_13wk35	F	10.0.0	10.1.0	R5s130681
RP-62	RP-131868	0126	-	Correction of IMS test case 12.2 over LTE with 34.229-3 test model	F	10.0.0	10.1.0	R5s130684
RP-62	RP-131868	0127	-	Correction of IMS test case 12.13 over LTE with 34.229-3 test model	F	10.0.0	10.1.0	R5s130685
RP-62	RP-131868	0128	-	Correction of IMS test case 8.1 over LTE with 34.229-3 test model	F	10.0.0	10.1.0	R5s130710
RP-62	RP-131868	0129	-	Correction to usage of constant tsc_IMS_AcceptContactValue	F	10.0.0	10.1.0	R5s130738
RP-62	RP-131868	0130	-	Correction to SMS over IMS test case 18.2	F	10.0.0	10.1.0	R5s130739
RP-62	RP-131868	0131	-	Corrections to IMS codec selection test case 16.1 and 16.2	F	10.0.0	10.1.0	R5s130742
RP-62	RP-131868	0132	-	Correction to IMS Call Control test case 12.13	F	10.0.0	10.1.0	R5s130743
RP-62	RP-131868	0133	-	Correction to GCF WI-154 IMS Emergency Call over EPS test case 19.1.2	F	10.0.0	10.1.0	R5s130760
RP-62	RP-131868	0134	-	Corrections to number of channels in SDP in 34.229-3 test model	F	10.0.0	10.1.0	R5s130798
RP-62	RP-131867	0135	-	CR to 34.229-3 (prose) update to v10.1.0	F	10.0.0	10.1.0	RP-131867
RP-63	R5-140319	0136	-	Routine maintenance and updates	F	10.1.0	10.2.0	R5-140931
RP-63	RP-140313	0137	-	Addition of GCF WI-171 MTSI MO speech call / SSAC test case 12.18 (using TS 36.523-3 test model)	B	10.1.0	10.2.0	R5s130766
RP-63	RP-140313	0138	-	Addition of GCF WI-171 IMS Emergency call / SSAC test case 12.20 (using TS 36.523-3 test model)	B	10.1.0	10.2.0	R5s130768
RP-63	RP-140313	0139	-	Re-verification of MTSI MT speech call test case 12.13 (... using TS 36.523-3 test model)	F	10.1.0	10.2.0	R5s130770
RP-63	RP-140313	0140	-	Re-verification of IMS test case 16.1 over LTE with 34.229-3 test model	F	10.1.0	10.2.0	R5s130808
RP-63	RP-140313	0141	-	Re-verification of IMS test case 16.2 over LTE with 34.229-3 test model	F	10.1.0	10.2.0	R5s130810
RP-63	RP-140313	0142	-	Correction of IMS test case 12.2 over LTE with 34.229-3 test model	F	10.1.0	10.2.0	R5s130885
RP-63	RP-140313	0143	-	Correction of IMS test case 12.12 over LTE with 34.229-3 test model	F	10.1.0	10.2.0	R5s130894
RP-63	RP-140313	0144	-	Corrections for common IMS functions	F	10.1.0	10.2.0	R5s130897
RP-63	RP-140313	0145	-	Correction to GCF WI-103 IMS test case 11.2 with	F	10.1.0	10.2.0	R5s130900

Meeting	TSG doc	CR	Rev	Subject	Cat	Old vers	New vers	WG doc
				36.523-3 Test Model				
RP-63	RP-140313	0146	-	Correction to Postamble handling for IMS deregistration procedure	F	10.1.0	10.2.0	R5s130901
RP-63	RP-140313	0147	-	Correction to fl_EUTRA_IPCAN_ActivateDedicatedEpsBearer_SpeechCall	F	10.1.0	10.2.0	R5s130916
RP-63	RP-140313	0148	-	Correction of IMS test case 8.10 over LTE with 34.229-3 test model	F	10.1.0	10.2.0	R5s130925
RP-63	RP-140313	0149	-	Addition of GCF WI-103 IMS MTSI test case 16.3 over 36.523-3 Test Model	B	10.1.0	10.2.0	R5s130956
RP-63	RP-140313	0150	-	Addition of GCF WI-103 IMS MTSI test case 16.4 over 36.523-3 Test Model	B	10.1.0	10.2.0	R5s130958
RP-63	RP-140313	0151	-	Correction to GCF WI-154 IMS Emergency Call over EPS test case 19.1.2	F	10.1.0	10.2.0	R5s130978
RP-63	RP-140313	0152	-	Correction to GCF WI-103 IMS MTSI test case 12.13	F	10.1.0	10.2.0	R5s130985
RP-63	RP-140313	0153	-	Addition of GCF WI-154 IMS Emergency Call over EPS test case 19.4.1	B	10.1.0	10.2.0	R5s130990
RP-63	RP-140313	0154	-	Correction to GCF WI-103 IMS MTSI test case 9.2	F	10.1.0	10.2.0	R5s131004
RP-63	RP-140313	0155	-	Correction to GCF WI-103 IMS MTSI test case 11.2	F	10.1.0	10.2.0	R5s131040
RP-63	RP-140313	0156	-	Correction of common altsteps in IMS PTC for test case 11.2	F	10.1.0	10.2.0	R5s140003
RP-63	RP-140313	0157	-	Correction for IMS common function f_IMS_InviteRequest_MessageHeaderRX()	F	10.1.0	10.2.0	R5s140005
RP-63	RP-140313	0158	-	Re-verification of IMS test case 15.11 over LTE with 34.229-3 test model	F	10.1.0	10.2.0	R5s140017
RP-63	RP-140312	0159	-	CR to 34.229-3: Add new verified and e-mail agreed TTCN test cases in the TC lists in 34.229-3 (prose), Annex A	F	10.1.0	10.2.0	RP-140312
RP-64	RP-140812	0160	-	Routine maintenance and updates	F	10.2.0	10.3.0	R5-142961
RP-64	RP-140822	0161	-	Addition of GCF WI-154 IMS Emergency Call over EPS test case 19.5.6 (with TS 36.523-3 test model)	F	10.2.0	10.3.0	R5s140037
RP-64	RP-140822	0162	-	Addition of GCF WI-154 IMS Emergency Call over EPS test case 19.5.10 (with TS 36.523-3 test model)	F	10.2.0	10.3.0	R5s140039
RP-64	RP-140822	0163	-	Addition of GCF WI-103 IMS MTSI Testcase 15.28 with 36.523-3 Test Model	F	10.2.0	10.3.0	R5s140092
RP-64	RP-140822	0164	-	Re-verification of GCF WI-103 IMS MTSI Testcase 15.11 over 36.523-3 Test Model	F	10.2.0	10.3.0	R5s140121
RP-64	RP-140822	0165	-	Addition of GCF WI-154 IMS Emergency Testcase 19.4.5 with 36.523-3 Test Model	F	10.2.0	10.3.0	R5s140123
RP-64	RP-140822	0166	-	Correction of GCF WI-103 IMS MTSI Testcase 9.1	F	10.2.0	10.3.0	R5s140136
RP-64	RP-140822	0167	-	Correction to GCF WI-171 IMS SSAC testcase 12.20	F	10.2.0	10.3.0	R5s140137
RP-64	RP-140822	0168	-	Correction of P-Preferred-Service and P-Asserted-Service usage over LTE with 34.229-3 test model	F	10.2.0	10.3.0	R5s140141
RP-64	RP-140822	0169	-	Addition of GCF WI-103 IMS MO Call test case 12.2a (... with both TS 36.523-3 and TS 34.229-3 test model)	F	10.2.0	10.3.0	R5s140142
RP-64	RP-140822	0170	-	Correction to GCF WI-171 SSAC testcase 12.20	F	10.2.0	10.3.0	R5s140168

Meeting	TSG doc	CR	Rev	Subject	Cat	Old vers	New vers	WG doc
RP-64	RP-140822	0171	-	Correction to GCF WI-154 IMS Emergency Call testcase 19.1.2	F	10.2.0	10.3.0	R5s140171
RP-64	RP-140822	0172	-	Correction to GCF WI-154 IMS Emergency Call testcase 19.5.6	F	10.2.0	10.3.0	R5s140172
RP-64	RP-140822	0173	-	Correction to IMS function f_IMS_Dialog_SetRemoteTag	F	10.2.0	10.3.0	R5s140173
RP-64	RP-140822	0174	-	Correction of IMS function f_IMS_PTC_ImInfo_DialogInit	F	10.2.0	10.3.0	R5s140174
RP-64	RP-140822	0175	-	Correction to Postamble Procedure for IMS Testcases	F	10.2.0	10.3.0	R5s140175
RP-64	RP-140822	0176	-	Correction to GCF WI-103 IMS MTSI Testcases 9.1 and 9.2	F	10.2.0	10.3.0	R5s140176
RP-64	RP-140822	0177	-	Correction of GCF WI-103 IMS MTSI Testcase 15.28	F	10.2.0	10.3.0	R5s140178
RP-64	RP-140822	0178	-	Correction to IMS Route header in ACK sent by SS	F	10.2.0	10.3.0	R5s140194
RP-64	RP-140822	0179	-	Correction to 183 Session Progress Message	F	10.2.0	10.3.0	R5s140204
RP-64	RP-140822	0180	-	Correction to TCP Connection Close procedure for IMS Testcases	F	10.2.0	10.3.0	R5s140219
RP-64	RP-140822	0181	-	Correction to IMS Main PTC Function	F	10.2.0	10.3.0	R5s140243
RP-64	RP-140822	0182	-	Correction of f_IMS_AckRequest_MessageHeaderRX()	F	10.2.0	10.3.0	R5s140264
RP-64	RP-140822	0183	-	Correction of f_IPCAN_StartProcedure	F	10.2.0	10.3.0	R5s140265
RP-64	RP-140822	0184	-	spi and port values	F	10.2.0	10.3.0	R5s140266
RP-64	RP-140822	0185	-	Correction to GCF WI-103 IMS Call Control Test Case 11.2	F	10.2.0	10.3.0	R5s140303
RP-64	RP-140822	0186	-	Correction to SMS over IMS Test Case 18.1	F	10.2.0	10.3.0	R5s140304
RP-64	RP-140822	0187	-	Re-verification of IMS test case 15.27 over LTE with 34.229-3 test model	F	10.2.0	10.3.0	R5s140307
RP-64	RP-140822	0188	-	Re-verification of IMS test case 15.12 over LTE with 34.229-3 test model	F	10.2.0	10.3.0	R5s140324
RP-64	RP-140822	0189	-	Addition of GCF WI-154 IMS Emergency Call over EPS test case 19.5.9 with 36.523-3 test model	F	10.2.0	10.3.0	R5s140329
RP-64	RP-140822	0190	-	Correction to GCF WI-171 IMS SSAC Testcase 12.18	F	10.2.0	10.3.0	R5s140334
RP-64	RP-140822	0191	-	Correction to WI-103 IMS MTSI Testcase 11.1	F	10.2.0	10.3.0	R5s140342
RP-64	RP-140822	0192	-	Correction for checking of via Header in IMS response messages	F	10.2.0	10.3.0	R5s140350
RP-64	RP-140822	0193	-	Verification of IMS test case 8.11 over LTE with 34.229-3 test model	F	10.2.0	10.3.0	R5s140356
RP-64	RP-140822	0194	-	Corrections for IMS MO call setup sequence with preconditions	F	10.2.0	10.3.0	R5s140359
RP-64	RP-140822	0195	-	Corrections to de-registration procedure	F	10.2.0	10.3.0	R5s140428
RP-64	RP-140821	0196	-	CR to 34.229-3: Add new verified and e-mail agreed TTCN test cases in the TC lists in 34.229-3 (prose), Annex A	F	10.2.0	10.3.0	RP-140821

History

Document history		
V10.0.0	October 2013	Publication
V10.1.0	January 2014	Publication
V10.2.0	March 2014	Publication
V10.3.0	July 2014	Publication