



**Universal Mobile Telecommunications System (UMTS);
LTE;
Internet Protocol (IP) multimedia call control protocol based on
Session Initiation Protocol (SIP)
and Session Description Protocol (SDP);
User Equipment (UE) conformance specification;
Part 3: Abstract test suite (ATS)
(3GPP TS 34.229-3 version 13.4.0 Release 13)**



Reference

RTS/TSGR-0534229-3vD40

Keywords

LTE,UMTS

ETSI

650 Route des Lucioles
F-06921 Sophia Antipolis Cedex - FRANCE

Tel.: +33 4 92 94 42 00 Fax: +33 4 93 65 47 16

Siret N° 348 623 562 00017 - NAF 742 C
Association à but non lucratif enregistrée à la
Sous-Préfecture de Grasse (06) N° 7803/88

Important notice

The present document can be downloaded from:

<http://www.etsi.org/standards-search>

The present document may be made available in electronic versions and/or in print. The content of any electronic and/or print versions of the present document shall not be modified without the prior written authorization of ETSI. In case of any existing or perceived difference in contents between such versions and/or in print, the only prevailing document is the print of the Portable Document Format (PDF) version kept on a specific network drive within ETSI Secretariat.

Users of the present document should be aware that the document may be subject to revision or change of status.

Information on the current status of this and other ETSI documents is available at

<https://portal.etsi.org/TB/ETSIDeliverableStatus.aspx>

If you find errors in the present document, please send your comment to one of the following services:

<https://portal.etsi.org/People/CommiteeSupportStaff.aspx>

Copyright Notification

No part may be reproduced or utilized in any form or by any means, electronic or mechanical, including photocopying and microfilm except as authorized by written permission of ETSI.

The content of the PDF version shall not be modified without the written authorization of ETSI.

The copyright and the foregoing restriction extend to reproduction in all media.

© ETSI 2017.

All rights reserved.

DECT™, **PLUGTESTS™**, **UMTS™** and the ETSI logo are trademarks of ETSI registered for the benefit of its Members.

3GPP™ and **LTE™** are trademarks of ETSI registered for the benefit of its Members and of the 3GPP Organizational Partners.

oneM2M logo is protected for the benefit of its Members.

GSM® and the GSM logo are trademarks registered and owned by the GSM Association.

Intellectual Property Rights

IPRs essential or potentially essential to the present document may have been declared to ETSI. The information pertaining to these essential IPRs, if any, is publicly available for **ETSI members and non-members**, and can be found in ETSI SR 000 314: "*Intellectual Property Rights (IPRs); Essential, or potentially Essential, IPRs notified to ETSI in respect of ETSI standards*", which is available from the ETSI Secretariat. Latest updates are available on the ETSI Web server (<https://ipr.etsi.org/>).

Pursuant to the ETSI IPR Policy, no investigation, including IPR searches, has been carried out by ETSI. No guarantee can be given as to the existence of other IPRs not referenced in ETSI SR 000 314 (or the updates on the ETSI Web server) which are, or may be, or may become, essential to the present document.

Foreword

This Technical Specification (TS) has been produced by ETSI 3rd Generation Partnership Project (3GPP).

The present document may refer to technical specifications or reports using their 3GPP identities, UMTS identities or GSM identities. These should be interpreted as being references to the corresponding ETSI deliverables.

The cross reference between GSM, UMTS, 3GPP and ETSI identities can be found under <http://webapp.etsi.org/key/queryform.asp>.

Modal verbs terminology

In the present document "**shall**", "**shall not**", "**should**", "**should not**", "**may**", "**need not**", "**will**", "**will not**", "**can**" and "**cannot**" are to be interpreted as described in clause 3.2 of the [ETSI Drafting Rules](#) (Verbal forms for the expression of provisions).

"**must**" and "**must not**" are **NOT** allowed in ETSI deliverables except when used in direct citation.

Contents

| | |
|--|----|
| Intellectual Property Rights | 2 |
| Foreword..... | 2 |
| Modal verbs terminology..... | 2 |
| Foreword..... | 5 |
| Introduction | 5 |
| 1 Scope | 6 |
| 2 References | 6 |
| 3 Definitions and abbreviations..... | 9 |
| 3.1 Definitions | 9 |
| 3.2 Abbreviations | 9 |
| 4 Requirements on the TTCN development..... | 9 |
| 5 Test method and test model..... | 9 |
| 5.1 Test method | 9 |
| 5.2 IMS CC test model..... | 9 |
| 5.2.1 Transport protocol | 18 |
| 5.2.2 IMS CC test cases over IP-CAN test model | 19 |
| 5.3 Upper Tester (UT)..... | 19 |
| 5.4 TTCN-3..... | 19 |
| 5.5 Support of XCAP | 19 |
| 5.5.1 XCAP Server | 19 |
| 5.5.2 HTTP Signalling..... | 20 |
| 5.6 Void..... | 21 |
| 6 ASP definitions | 21 |
| 6.1 Void..... | 21 |
| 6.2 Void..... | 21 |
| 6.3 Void..... | 21 |
| 6.4 Void..... | 21 |
| 6.5 XCAP server ASP definitions | 21 |
| 7 Codec definitions for IP User Data | 22 |
| 7.1 Introduction | 22 |
| 7.2 General Aspects..... | 22 |
| 7.3 Requirements on abstract message syntax for IMS (SIP, SDP)..... | 23 |
| 7.3.1 Type definition - Syntax / Semantic aspects..... | 23 |
| 7.3.2 Deviations of the type definition semantic | 23 |
| 7.3.3 Additional requirements for codec implementations (SIP/IMS Message | 24 |
| 7.3.3.1 Differences between BNF - TTCN-3 Type Mapping..... | 24 |
| 7.3.3.2 URL Encoding | 28 |
| 7.3.4 Additional requirements for codec implementations (Message Body) | 28 |
| 7.3.5 Additional requirements for codec implementations (SDP Body)..... | 28 |
| 7.3.5.1 Differences between BNF - SDP Type Mapping | 28 |
| 7.3.5.2 Defined attributes..... | 30 |
| 7.3.6 Additional requirements for codec implementations (HTTP)..... | 31 |
| 7.3.7 Additional requirements for codec implementations (XML)..... | 31 |
| 7.4 Requirements for codec implementations (DHCP, DNS) | 31 |
| 8 Design consideration | 31 |
| 8.1 Void..... | 31 |
| 8.2 Void..... | 31 |
| 8.3 Void..... | 31 |
| 8.4 AT commands | 31 |
| 8.5 Timer Tolerances..... | 32 |
| 8.6 Bearer information for UTRAN | 32 |

| | | |
|-------------------------------|--|-----------|
| Annex A (normative): | Abstract Test Suites (ATS)..... | 33 |
| A.1 | Version of specifications | 33 |
| A.2 | IMS-CC ATS..... | 33 |
| A.2.1 | Void..... | 36 |
| A.2.2 | Void..... | 36 |
| A.2.3 | Void..... | 36 |
| Annex B (normative): | Partial IXIT proforma..... | 37 |
| B.0 | Introduction | 37 |
| B.1 | Parameter values | 37 |
| B.1.1 | PIXITs | 37 |
| B.2 | MMI Commands | 39 |
| Annex C: | Void | 40 |
| Annex D: | Void | 41 |
| Annex E (informative): | TTCN3 style guide for 3GPP IMS ATS..... | 42 |
| Annex F (informative): | BNF Message Definitions | 43 |
| Annex G (Normative): | SIP Type Definitions and XSD References..... | 44 |
| G.1 | LibSip_MessageBodyTypes..... | 45 |
| G.1.1 | MIMETypes | 45 |
| G.2 | References to TTCN-3 | 46 |
| Annex H (informative): | TTCN-3 Definitions of Common Interfaces | 47 |
| H.1 | IMS_PTC_CoordMsg | 47 |
| H.2 | IMS_ASP_TypeDefs..... | 50 |
| H.3 | HTTP_ASP_TypeDefs..... | 53 |
| H.3.1 | HTTP_ASP_Definitions..... | 53 |
| H.3.2 | HTTP_Port_Definitions | 55 |
| H.4 | References to TTCN-3 | 55 |
| Annex I (informative): | Change history | 56 |
| History | | 72 |

Foreword

This Technical Specification has been produced by the 3rd Generation Partnership Project (3GPP).

The contents of the present document are subject to continuing work within the TSG and may change following formal TSG approval. Should the TSG modify the contents of the present document, it will be re-released by the TSG with an identifying change of release date and an increase in version number as follows:

Version x.y.z

where:

x the first digit:

- 1 presented to TSG for information;
- 2 presented to TSG for approval;
- 3 or greater indicates TSG approved document under change control.

Y the second digit is incremented for all changes of substance, i.e. technical enhancements, corrections, updates, etc.

Z the third digit is incremented when editorial only changes have been incorporated in the document.

Introduction

The present document is 3rd part of a multi-part conformance test specification for UE and is *valid for 3GPP Release 5 and above*. The specification contains a TTCN design frame work and the detailed test specifications in TTCN for the UE conformance at the Gm reference point.

3GPP TS 34.229-1 [5] contains a conformance test description in prose.

3GPP TS 34.229-2 [6] contains a pro-forma for the UE Implementation Conformance Statement (ICS).

3GPP TS 34.229-3 the present document.

1 Scope

The present document specifies the protocol conformance testing in TTCN for the 3GPP User Equipment (UE) at the Gm interface.

The present document is the 3rd part of a multi-part test specification, 3GPP TS 34.229. The following TTCN test specification and design considerations can be found in the present document:

- the overall test suite structure;
- the testing architecture;
- the test methods and PCO definitions;
- the test configurations;
- the design principles, assumptions, and used interfaces to the TTCN tester (System Simulator);
- TTCN styles and conventions;
- the partial PIXIT proforma;
- the TTCN files for the mentioned protocols tests.

The Abstract Test Suites designed in the document are based on the test cases specified in prose (3GPP TS 34.229-1 [5]).

The present document is valid for UE implemented according 3GPP Releases starting from Release 5 up to the Release indicated on the cover page of the present document.

2 References

The following documents contain provisions which, through reference in this text, constitute provisions of the present document.

- References are either specific (identified by date of publication, edition number, version number, etc.) or non-specific.
- For a specific reference, subsequent revisions do not apply.
- For a non-specific reference, the latest version applies. In the case of a reference to a 3GPP document (including a GSM document), a non-specific reference implicitly refers to the latest version of that document in the same Release as the present document unless the context in which the reference is made suggests a different Release is relevant (information on the applicable release in a particular context can be found in e.g. test case title, description or applicability, message description or content).

- [1] 3GPP TR 21.905: "Vocabulary for 3GPP Specifications".
- [2] 3GPP TS 34.123-1: "User Equipment (UE) conformance specification; Part 1: Protocol conformance specification".
- [3] 3GPP TS 34.123-2: "User Equipment (UE) conformance specification; Part 2: Implementation Conformance Statement (ICS) proforma specification".
- [4] 3GPP TS 34.123-3: "User Equipment (UE) conformance specification; Part 3: Abstract Test Suites (ATS)".
- [5] 3GPP TS 34.229-1: "Internet Protocol (IP) multimedia call control protocol based on Session Initiation Protocol (SIP) and Session Description Protocol (SDP); User Equipment (UE) conformance specification; Part 1: Protocol conformance specification".

- [6] 3GPP TS 34.229-2: "Internet Protocol (IP) multimedia call control protocol based on Session Initiation Protocol (SIP) and Session Description Protocol (SDP); User Equipment (UE) conformance specification; Part 2: Implementation Conformance Statement (ICS) specification".
- [7] 3GPP TS 34.108: "Common test environments for User Equipment (UE) conformance testing".
- [8] ISO/IEC 9646-1: "Information technology - Open systems interconnection - Conformance testing methodology and framework - Part 1: General concepts".
- [9] ISO/IEC 9646-7: "Information technology - Open systems interconnection - Conformance testing methodology and framework - Part 7: Implementation Conformance Statements".
- [10] ETSI ETS 300 406 (1995): "Methods for testing and Specification (MTS); Protocol and profile conformance testing specifications; Standardization methodology".
- [11] 3GPP TS 24.229: "IP Multimedia Call Control Protocol based on Session Initiation Protocol (SIP) and Session Description Protocol (SDP); Stage 3".
- [12] ETSI ES 201 873: "Methods for Testing and Specification (MTS); The Testing and Test Control Notation version 3".
- [13] IETF RFC 3320: "Signalling Compression (SigComp)".
- [14] IETF RFC 3485: "The Session Initiation Protocol (SIP) and Session Description Protocol (SDP) Static Dictionary for Signalling Compression (SigComp)".
- [15] IETF RFC 3486: "Compressing the Session Initiation Protocol (SIP)".
- [16] IETF RFC 3261: "SIP: Session Initiation Protocol".
- [17] IETF RFC 4566: "SDP: Session Description Protocol".
- [18] IETF RFC 1035: "Domain names - implementation and specification".
- [19] IETF RFC 1533: "DHCP Options and BOOTP Vendor Extensions".
- [20] IETF RFC 2131: "Dynamic Host Configuration Protocol".
- [21] IETF RFC 3315: "Dynamic Host Configuration Protocol for Ipv6 (DHCPv6)".
- [22] IETF RFC 3319: "Dynamic Host Configuration Protocol (DHCPv6) Options for Session Initiation Protocol (SIP) Servers".
- [23] IETF RFC 3361: "Dynamic Host Configuration Protocol (DHCP-for-Ipv4) Option for Session Initiation Protocol (SIP) Servers".
- [24] IETF RFC 3680: "A Session Initiation Protocol (SIP) Event Package for Registrations".
- [25] 3GPP TS 24.173: "IMS multimedia telephony communication service and supplementary services; Stage 3".
- [26] IETF RFC 4825: "The Extensible Markup Language (XML) Configuration Access Protocol (XCAP)".
- [27] IETF RFC 2616: "Hypertext Transfer Protocol – HTTP/1.1".
- [28] 3GPP TS 36.523-1: "Evolved Universal Terrestrial Radio Access (E-UTRA) and Evolved Packet Core (EPC); User Equipment (UE) conformance specification; Part 1: Protocol conformance specification".
- [29] 3GPP TS 36.523-2: "Evolved Universal Terrestrial Radio Access (E-UTRA) and Evolved Packet Core (EPC); User Equipment (UE) conformance specification; Part 2: Implementation Conformance Statement (ICS) proforma specification".
- [30] 3GPP TS 36.523-3: "Evolved Universal Terrestrial Radio Access (E-UTRA) and Evolved Packet Core (EPC); User Equipment (UE) conformance specification; Part 3: Test suites".

- [31] 3GPP TS 36.508: "Evolved Universal Terrestrial Radio Access (E-UTRA) and Evolved Packet Core (EPC); Common test environments for User Equipment (UE) conformance testing".
- [32] 3GPP TS 24.173: "IMS Multimedia telephony communication service and supplementary services; Stage 3".
- [33] 3GPP TS 24.109: "Bootstrapping interface (Ub) and network application function interface (Ua); Protocol details".
- [34] 3GPP TS 33.220: "Generic Authentication Architecture (GAA); Generic Bootstrapping Architecture".
- [35] 3GPP TS 33.222: "Generic Authentication Architecture (GAA); Access to network application functions using Hypertext Transfer Protocol over Transport Layer Security (HTTPS)".
- [36] 3GPP TS 24.623: "Extensible Markup Language (XML) Configuration Access Protocol (XCAP) over the Ut interface for Manipulating Supplementary Services".
- [37] RFC 2617: "HTTP Authentication: Basic and Digest Access Authentication".
- [38] RFC 3966: "The tel URI for Telephone Numbers".
- [39] RFC 2141: "URN Syntax".
- [40] 3GPP TS 24.604: "Communication Diversion (CDIV) using IP Multimedia (IM) Core Network (CN) subsystem; Protocol specification".
- [41] 3GPP TS 24.607: "Originating Identification Presentation (OIP) and Originating Identification Restriction (OIR) using IP Multimedia (IM) Core Network (CN) subsystem; Protocol specification".
- [42] 3GPP TS 24.608: "Terminating Identification Presentation (TIP) and Terminating Identification Restriction (TIR) using IP Multimedia (IM) Core Network (CN) subsystem; Protocol specification".
- [43] 3GPP TS 24.611: "Anonymous Communication Rejection (ACR) and Communication Barring (CB) using IP Multimedia (IM) Core Network (CN) subsystem; Protocol specification".
- [44] IETF RFC 4119 "A Presence-based GEOPRIV Location Object Format".
- [45] IETF RFC 4575: "A Session Initiation Protocol (SIP) Event Package for Conference State".
- [46] IETF RFC 5628: "Registration Event Package Extension for Session Initiation Protocol (SIP) Globally Routable User Agent URIs (GRUUs)".
- [47] IETF RFC 3863 "Presence Information Data Format (PIDF)".
- [48] IETF RFC 4745: "Common Policy: A Document Format for Expressing Privacy Preferences".
- [49] 3GPP TS 27.007: "AT command set for 3G User Equipment (UE)".
- [50] 3GPP TS 34.229-4: "User Equipment (UE) conformance specification; Part 4: Enabler for IP multimedia applications testing".
- [51] 3GPP TS 24.237: "IP Multimedia (IM) Core Network (CN) subsystem IP Multimedia Subsystem (IMS) Service Continuity".
- [52] 3GPP TS 31.121: "UICC-terminal interface; Universal Subscriber Identity Module (USIM) application test specification".

3 Definitions and abbreviations

3.1 Definitions

For the purposes of the present document, the terms and definitions given in 3GPP TR 21.905 [1] and 3GPP TS 34.229-1 [5] apply.

3.2 Abbreviations

For the purposes of the present document, the abbreviations given in 3GPP TR 21.905 [1] and 3GPP TS 34.229-1 [5] apply.

4 Requirements on the TTCN development

A number of requirements are identified for the development and production of TTCN specification for 3GPP UE at the Gm reference point.

1. Top-down design, following 3GPP 34.229-1 [5], 3GPP TS 34.123-1 [2], 3GPP TS 34.108 [7].
2. A unique testing architecture and test method for testing all protocol layers of UE.
3. Uniform TTCN style and naming conventions.
4. Improve TTCN readability.
5. Using TTCN-3 (ES 201 873-1 [12]).
6. TTCN specification feasible, implementable and compilable.
7. Test cases shall be designed in a way for easily adaptable, upwards compatible with the evolution of the 3GPP core specifications and the future Releases.
8. The test declarations, data structures and data values shall be largely reusable.
9. Modularity and modular working method.
10. Minimizing the requirements of intelligence on the emulators of the lower testers.
11. Giving enough design freedom to the test equipment manufacturers.
12. Maximizing reuse of RFC BNF definitions from the relevant IETF core specifications.

In order to fulfil these requirements and to ensure the investment of the test equipment manufacturers having a stable testing architecture for a relatively long period, a unique testing architecture and test method are applied to the 3GPP UE protocol tests.

5 Test method and test model

5.1 Test method

5.2 IMS CC test model

The test model over E - UTRA is shown in Figure 5.2-1a, the test model over UTRAN is shown in figure 5.2-1b, the test model over WLAN is shown in figure 5.2-1c, and the test model over fixed access is shown in figure 5.2-1d (NOTE: the IPsec is not used by this model).

The IMS CC test cases are executed on top of the multi-testers test model according to TS 36.523-3[30] for E- UTRA and TS 34.123-3[4] clause 6A for UTRAN.

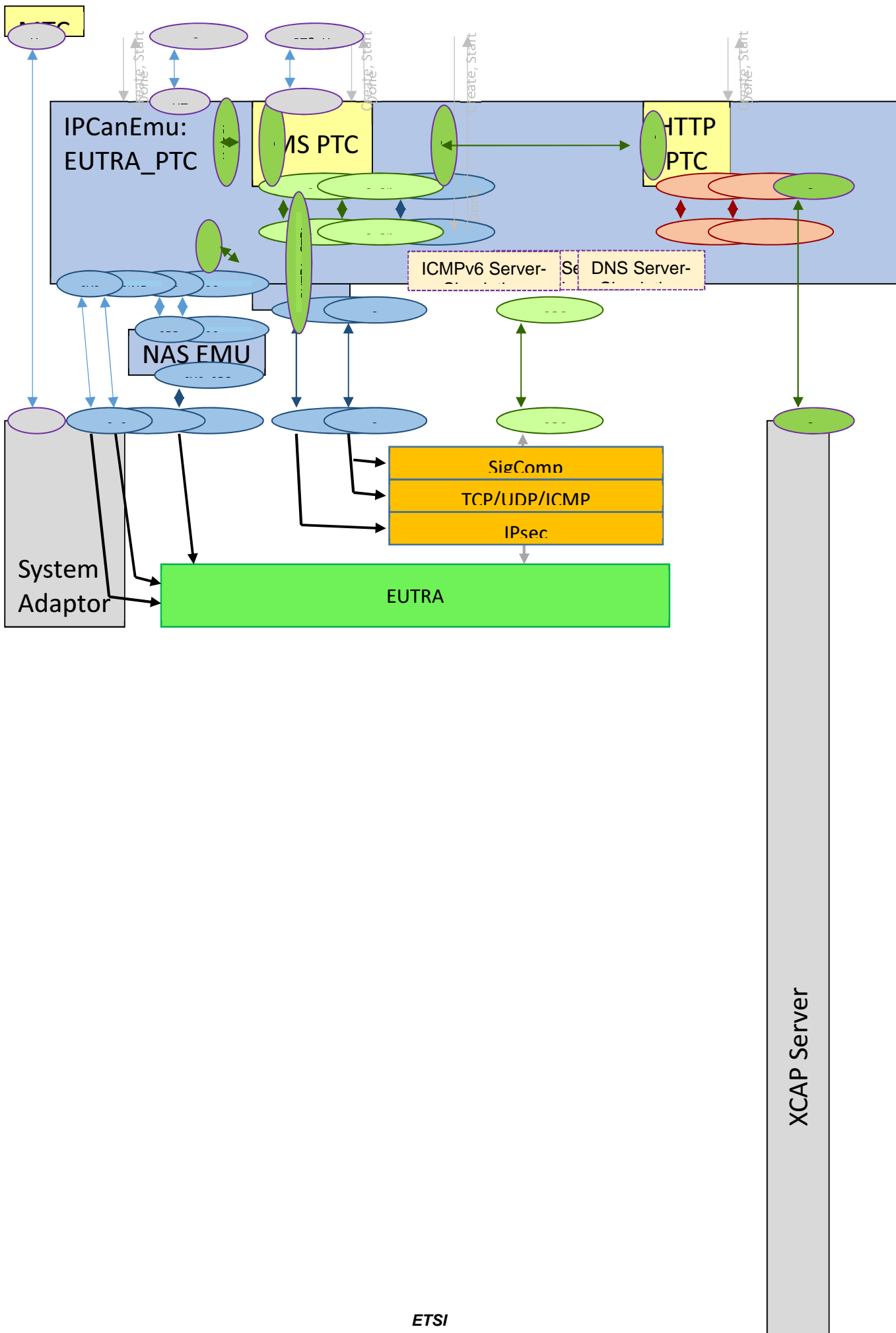

Figure 5.2-1a: Multi-TestersTest Model to support E-UTRA SS interface

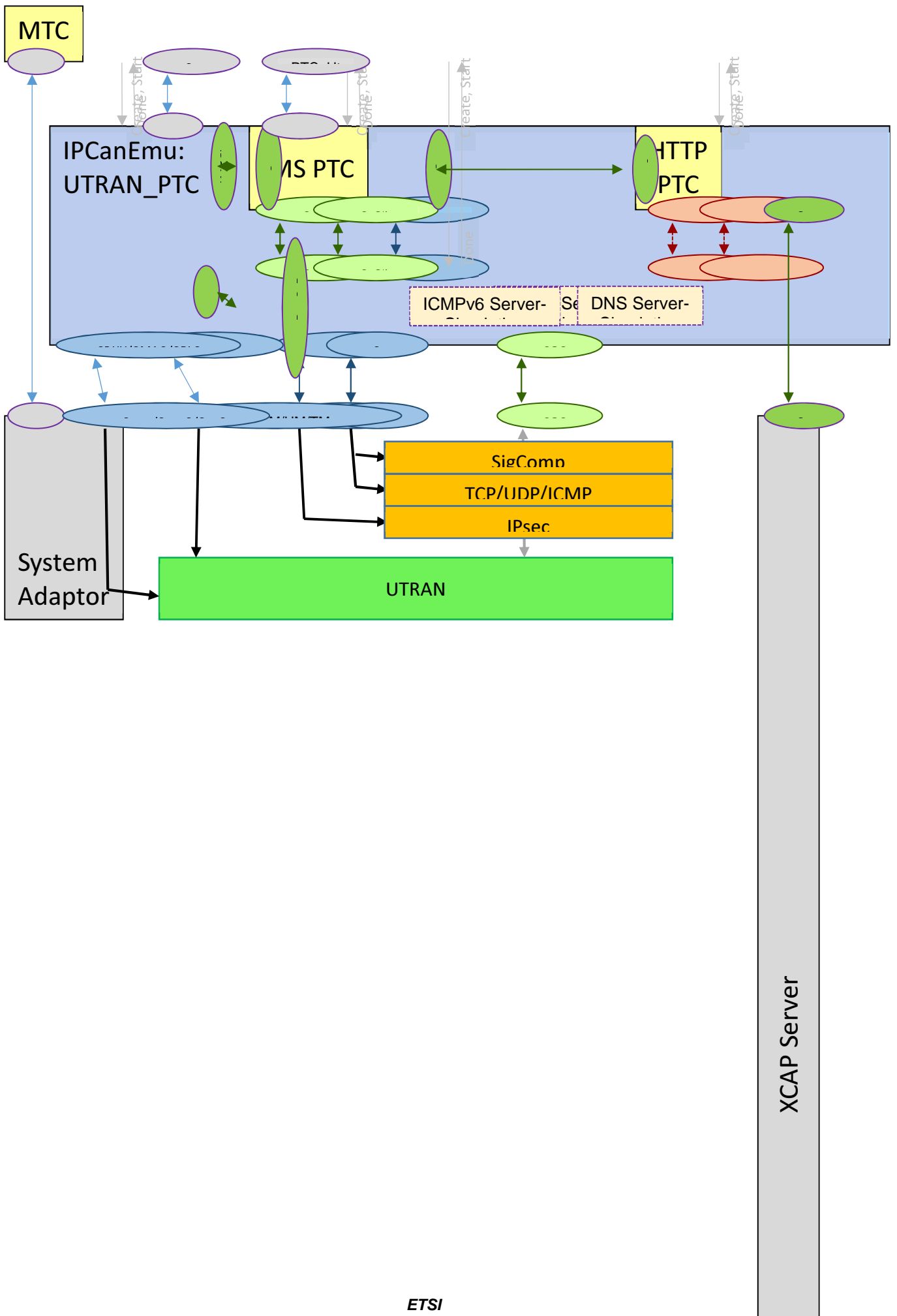

Figure 5.2-1b: Multi-Testers Test Model to support UTRAN SS interface

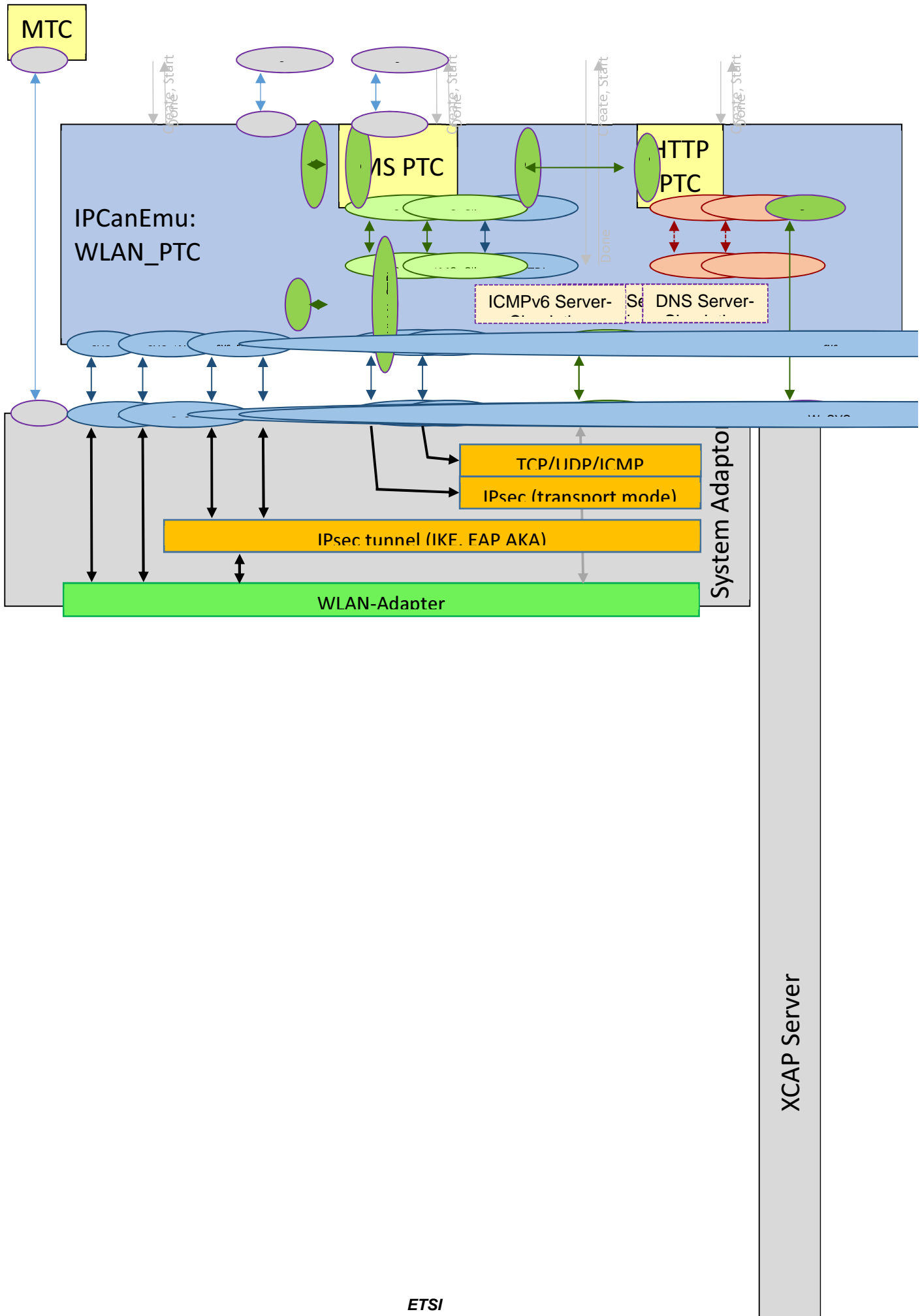

Figure 5.2-1c: Multi-Testers Test Model to support WLAN SS interface

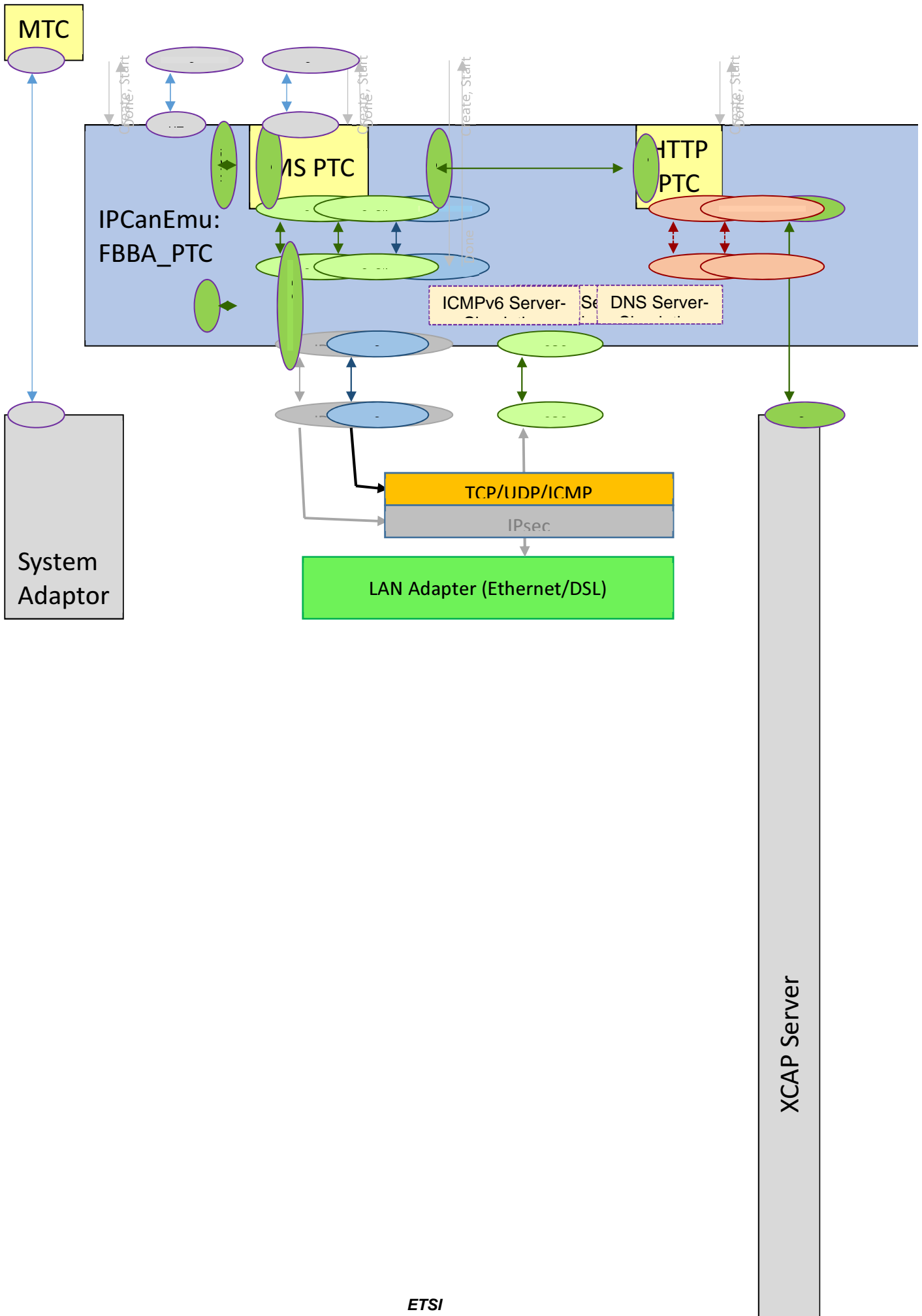

Figure 5.2-1d: Multi-Testers Test Model to support fixed access SS interface

The IMS CC test cases run on the IMS-PTC which controls the IPCanEmu and the IP-PTC. IPCanEmu is responsible for cell setup and DRB/RAB establishment and the IP-PTC controls the IP related configurations. IPCanEmu and IP-PTC interface to the SS according to TS 36.523-3[30] or TS 34.123-3 [4].

Clauses 4.2.4, 4.2.5 and 4.4.1.1 of TS 36.523-3 [30] describe the common handling of IP data in the multi-testers model regarding IMS signalling. In addition to support HTTP over TLS a TCP server may be established with additional parameters for TLS which may be required for XCAP (depending on the authentication mechanism to be applied for XCAP test case).

The test model extensions for support of XCAP are shown in Figure 5.2-2. Clause 5.5 provides further information regarding support of XCAP.

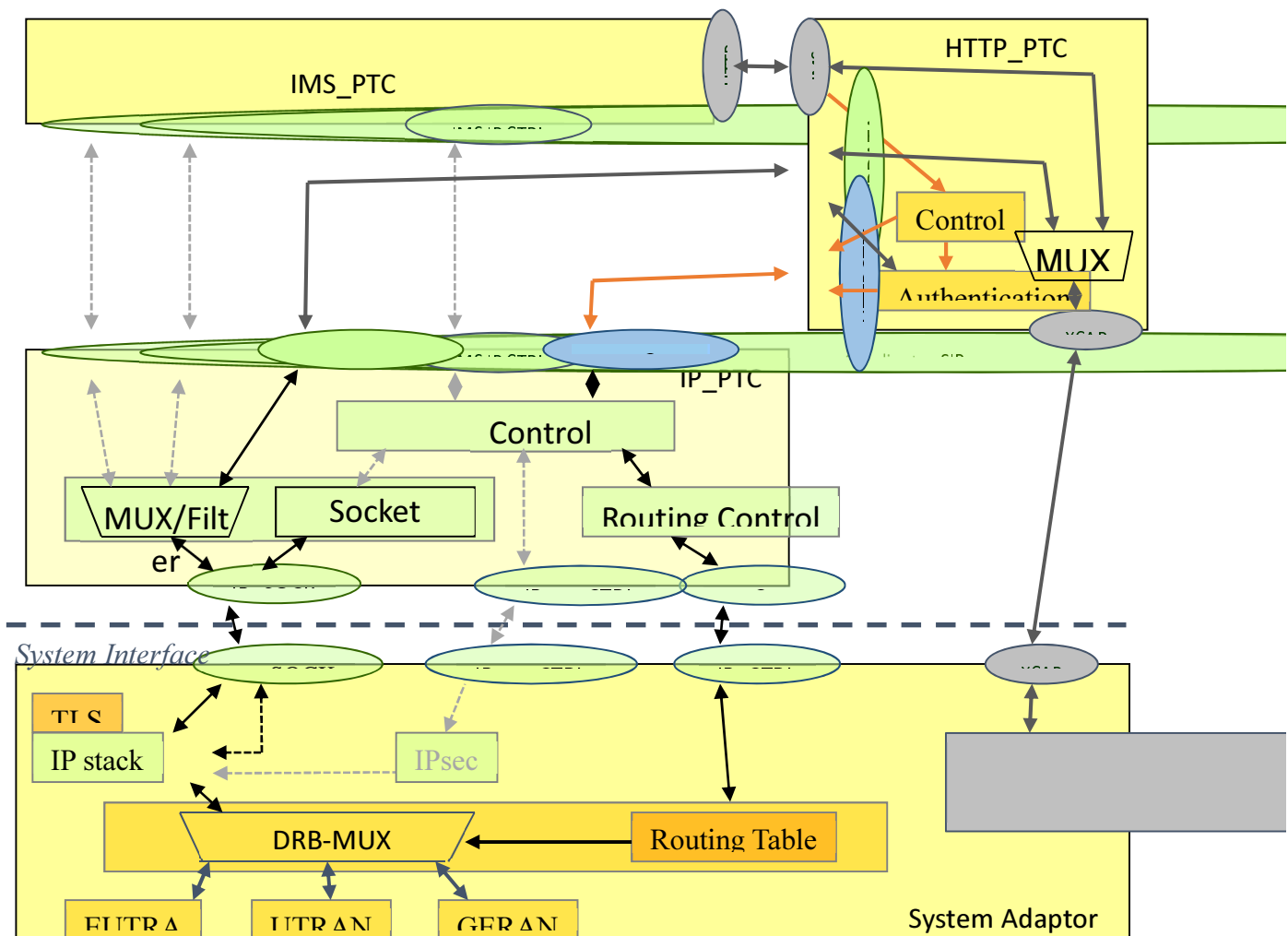

Figure 5.2-2: Extended IP model to handle HTTP/XCAP data

NOTE: Figure 5.2-2 is just an example; further details are SS implementation dependent.

5.2.1 Transport protocol

For SIP requests originated by the UE, the transport protocol in UL is selected by the UE. This information is extracted in the TTCN-3 and used in subsequent responses sent by the SS.

For SIP requests originated by the SS in DL UDP is used as transport protocol at the test. For the purpose of test coverage, TCP is used in the specific test cases as specified.

NOTE: According to RFC 3261 [16] clause 18.1.1 the server side (UE) has to be able to cope with a maximum datagram size of 65,535 bytes (independent of any guideline to restrict the maximum size of UDP packets at the client side).

5.2.2 IMS CC test cases over IP-CAN test model

The "Enabler for IP multimedia applications testing" is described in TS 34.229-4 [50]. In general IMS CC test cases can be run on this test model too as test case implementation - in general - is independent of the test model. The TTCN code for IMS and HTTP PTC is the same for TS 34.229-3 and TS 34.229-4 implementations whereas the MTC implementation is model specific. The implementation of the MTC, the IP-CAN/IP adaptor and the MMI system interface is part of TS 34.229-4 and out of scope for this document. Common interfaces are documented in annex H of this document.

5.3 Upper Tester (UT)

The upper tester interface is the same as defined in TS 36.523-3 [30] clause 5 for E - UTRA or TS 34.123-3[4] clause 6A.4 for UTRAN, with additional, IMS-specific AT commands as specified in clause 8.4 and IMS-specific MMI commands as specified in annex B.2.

5.4 TTCN-3

TTCN is used as specification language. ES 201 873 [12] (TTCN-3) is applied to the notation.

5.5 Support of XCAP

MTSI supplementary services (TS 24.173[25]) like communication barring (CB) and communication diversion (CDIV) require the XCAP protocol (RFC 4825[26]) for transporting and manipulating XML documents in the network describing these services. Test cases for these services are specified in TS 34.229-1 [5] clause 15. As shown in figure 5.2-2 the SS shall provide an XCAP server to support XCAP test cases; the TTCN interface to this server is specified in clause 6.5.

5.5.1 XCAP Server

Supplementary services are managed by the XCAP server in the *simservs* documents according to TS 24.623 [36]. Test cases manipulating data related to supplementary services are specified in TS 34.229-1 [5] clause 15. For simplification of the TTCN implementation, the XCAP server functionality shall be provided by the SS i.e. it is not implemented in the TTCN. Access to the XCAP server can be distinguished into:

- HTTP based transaction between the UE and the XCAP server
- Initialisation and validation of the *simservs* document according to the test cases

In addition the UE may exchange HTTP messages for authentication (depending on the UE's security capabilities); see figure 5.5.1-1.

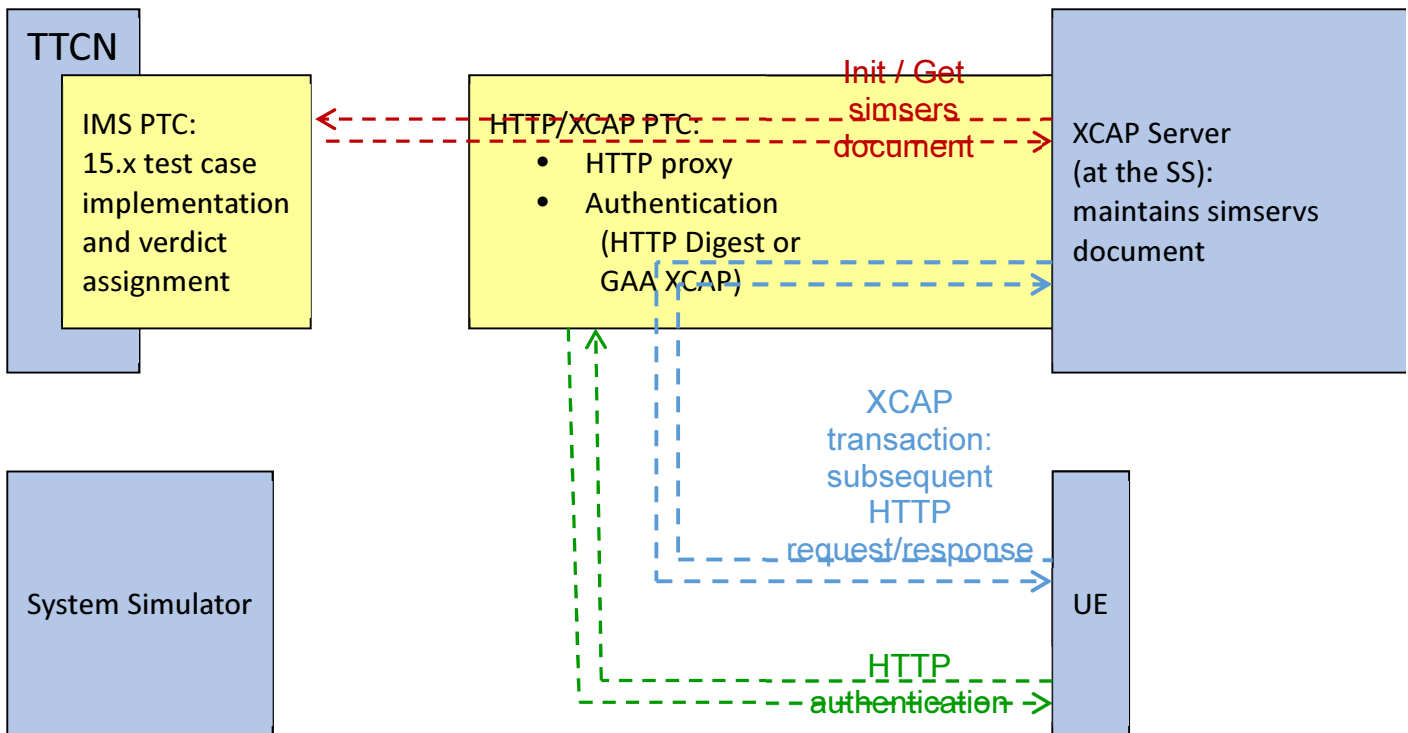

Figure 5.5.1-1: IMS CC test model

NOTE: In accordance to RFC 4825 clause 6.3 [26], the UE may use complex XPATH expressions to modify the simservs document but this shall be handled by the XCAP server; in the TTCN these expressions are not explicitly checked. Furthermore test case implementation itself does not use complex XPATH expressions to access the simservs document, but always considers the whole document.

5.5.2 HTTP Signalling

RFC 4825 [26] specifies the protocol for accessing user data in the XCAP server via HTTP requests. An HTTP request for an XCAP operation contains basically three components:

- Request line method, i.e. PUT, GET or DELETE
- Request line uri - The XCAP expression to be evaluated to access the XCAP document. The XCAP expression consists of the document selector followed by the separator “~~” followed by the node selector pointing to the user data to accessed or evaluated
- body - Describing the value (an xml fragment) referenced by the XCAP expression

Example 1

In order to set terminating-identity-presentation for user sip:ob.stf160@etsi.org, the UE sends following HTTP request:

```
PUT http://XCAP-Server/simservs.ngn.etsi.org/users/sip%3Aob.stf160%40etsi.org/simservs.xml/~/~/simservs/terminating-identity-presentation/%40active
Body: true
```

If successful, the XCAP server responds with

```
HTTP/1.1 200 OK
```

Example 2

To get the value of terminating-identity-presentation for user sip:ob.stf160@etsi.org, the UE sends following HTTP request:

GET
/simservs/terminating-identity-presentation/%40active

If successful, the XCAP server responds with

HTTP/1.1 200 OK
Body: true

In this example

```
//XCAP-server/simservs.ngn.etsi.org/users/ sip%3Aob.stf160%40etsi.org/simservs.xml/-
Document selector for user .
~~ - Document selector separator, see RFC 4825
/simservs/terminating-identity-presentation/%40active - Node selector pointing to the information in
the XCAP server to be accessed. This is an XPATH expression, see RFC 4825 section 6.3.
true - Is the xml fragment (in this case very simple) to be set as value of the XPATH expression
```

Following operations shall be implemented in the XCAP server, see RFC 4825.

GET - Returns the requested data as an XML fragment to be send to the UE

input parameters: charstring documentSelector, charstring xpathExpr
returns: XML fragment or XML document

PUT - Builds an XML subtree or sets an attribute given by the xmlFragment at the position pointed by the xpath expression

input parameters: charstring documentSelector, charstring xpathExpr, charstring xmlFragment or xmlDocument

DELETE - Deletes an XML subtree or sets an attribute given by the xmlFragment at the position pointed by the xpath expression

input parameters: charstring documentSelector, charstring xpathExpr

5.6 Void

6 ASP definitions

This clause defines abstract system primitives (ASPs) for system interfaces which are used additionally to the system interfaces defined in TS 36.523-3[30] and TS 34.123-3[4]. Further interfaces are documented in annex H to support the IP-CAN test model according to TS 34.229-4 [50] but these interfaces are not system interfaces in the scope of this document.

6.1 Void

6.2 Void

6.3 Void

6.4 Void

6.5 XCAP server ASP definitions

XCAP Layer ASPs are applicable to clause 5.2. and 5.6.

| | | |
|-----------------------|---|---|
| Name | XCAP_REQ | |
| Port | XCAP_PORT | |
| Comment | ASP type for sending a request to the external XCAP server according to RFC 4825 [26] | |
| Parameter Name | Parameter Type | Comment |
| method | charstring | GET, PUT, DELETE or RESET |
| xcapExpression | charstring | XCAP expression sent by the UE in its http request line |
| contentType | charstring | media type as contained in the HTTP content type header (optional) |
| xmlBody | charstring | XML fragment sent by the UE in its http body or sirmservs document initialised by the test cases (optional) |

| | | |
|-----------------------|--|--|
| Name | XCAP_RSP | |
| Port | XCAP_PORT | |
| Comment | ASP type for sending the response to the XCAP_REQ from the XCAP server to TTCN | |
| Parameter Name | Parameter Type | Comment |
| errorInfo | charstring | string indicating a system error (optional) |
| contentType | charstring | media type as contained in the HTTP content type header (optional) |
| xmlBody | charstring | Result returned by the XCAP server (optional) |

7 Codec definitions for IP User Data

7.1 Introduction

SIP is a text-based protocol, thus the message exchange between the UE and the SS are pure character strings. In the TTCN-3 ATS the messages are structured and optimized to take the advantage of TTCN-3 functionality, and to make the debugging and maintenance of the ATS easier.

7.2 General Aspects

IP user data for IMS conformance testing can be distinguished into:

1. text based: SIP (including SDP and XML messages), HTTP (see clause 7.4)
2. octetstring based: DHCP, DHCPv6, DNS (see clause 7.4)

In TTCN the following encoding information is used for user data:

Table 7.2-1

| Type definitions | Encoding |
|------------------|------------------------------|
| SMS Types | Tabular notated (see note 1) |
| DHCPv4-Codec | Tabular notated (see note 1) |
| DHCPv6-Codec | Tabular notated (see note 1) |
| DNS-Codec | Tabular notated (see note 1) |
| SIPCodec | (see clause 7.3) |
| SDPCodec | (see clause 7.3) |
| HttpCodec | (see clause 7.3) |

NOTE 1: Tabular notated is performed by concatenation of all the present fields in the TTCN-3 template.

NOTE 2: Encoding information is only needed for type definitions of peer-to-peer signalling; encoding of ASPs used for system configuration or as co-ordination messages between PTCs is out of scope for this document.

7.3 Requirements on abstract message syntax for IMS (SIP, SDP)

7.3.1 Type definition - Syntax / Semantic aspects

All given defined BNF grammars (e.g. the ABNF of RFC 3261) are unique. Thus the syntax tree for each syntactically correct message derived with these grammars are unique too and the parts of a message can be uniquely identified (represented) by the terminal phrase belonging to a non terminal symbol and its derivation path in the syntax tree.

The syntax tree of all given messages can be used to uniquely identify and describe the parts of the messages. The leaves are the part of every message and the nodes from the root to the leaves represent the sequence of rules to be applied to derive that part

The IMS/SIP root message type is an ordered structured type, which is represented as a record type in TTCN-3. For each grammar rule of the ABNF a TTCN-3 record type is declared with the specific name of the rule. The following rules are applied to the fields within a record:

- A non-terminal symbol is declared as a record type for this symbol.
- The order of the symbols in the rule are represented by an equal order of the fields.
- Repetitions are declared as 'set of' or 'record of' types.
- Options are represented as optional record/set fields.
- Alternatives are declared as union types.

7.3.2 Deviations of the type definition semantic

- Most of the 'literals' of a message (for example: the string "Via" or "v" in the message header fields) are not represented.
- The TTCN-3 charstring type is used where we stop structuring even if the ABNF uses structured types. More details found in clause 8.3.3.
- Wherever possible parts are mapped to their best type representation, e.g. DIGIT based rules are mapped to integer type not to a charstring type.
- All of the following delimiters (including preceding or following whitespace) defined by the ABNF grammar to separate the parts of a message are not represented (see note).

```

STAR      = SWS "*" SWS ; asterisk
SLASH     = SWS "/" SWS ; slash
EQUAL     = SWS "=" SWS ; equal
LPAREN    = SWS "(" SWS ; left parenthesis
RPAREN    = SWS ")" SWS ; right parenthesis
RAQUOT    = ">" SWS ; right angle quote
LAQUOT    = SWS "<"; left angle quote
COMMA     = SWS "," SWS ; comma
SEMI      = SWS ";" SWS ; semicolon
COLON     = SWS ":" SWS ; colon
LDQUOT    = SWS DQUOTE; open double quotation mark
RDQUOT    = DQUOTE SWS ; close double quotation mark
HCOLON    = *( SP / HTAB ) ":" SWS
SP        = single space
HTAB     = tab
SWS      = sep whitespace

```

NOTE: If they are present within a pure charstring they will be handled like a normal character and are still included.

- Messages which are not of interest to the test suite are left undecoded as a charstring and will not be further structured.

Further clarifications on the handling of delimiters are provided hereafter:

In many cases the TTCN-3 type definitions are of lower granularity than the BNF and the codec shall consider the TTCN type definitions only. Therefore as stated in the NOTE above the rules for handling of delimiters do not require delimiters to be blindly removed from strings but the codec shall only deal with the delimiters needed to encode/decode the TTCN-3 types; sub-structures of the BNF being mapped to TTCN-3 charstrings need to be handled in TTCN and are out of scope of the codec implementation.

Example 1:

According to the BNF Alert-Info is defined as

```
Alert-Info    = "Alert-Info" HCOLON alert-param *(COMMA alert-param)
alert-param  = LAQUOT absoluteURI RAQUOT *( SEMI generic-param )
```

The corresponding TTCN-3 type definition is

```
type record AlertInfo { fieldName fieldName (ALERT_INFO_E),
                        AlertInfoBody_List alertInfoBody optional }
type set of AlertInfoBody AlertInfoBody_List;
type record AlertInfoBody { charstring url,
                            SemicolonParam_List genericParams optional }
```

⇒ LAQUOT and RAQUOT are delimiters of the URI field which shall be removed by the codec in UL.

Example 2:

Some fields according to the BNF for SIP are defined as “(token LWS)/ quoted-string”, i.e. the field can be either a (case-insensitive) token or a quoted string. In general in TTCN this can be mapped

- a) to a charstring or
- b) to a union of two charstring (one for the token, one for the quoted string).

In case of a) the codec shall preserve the double-quotes for the quoted-string as otherwise it cannot be distinguished from a token anymore which is vital when case-sensitivity matters whereas in case of b) the double quotes shall be removed.

7.3.3 Additional requirements for codec implementations (SIP/IMS Message)

The SIP/IMS codec is based on a normalized encoding which is always produced by an encoder. Decoder implementations, however, have to handle normalization before, or when constructing the structured message value, e.g. long versus compact form, whitespace compression, delimiter removal, same header grouping, etc. All these aspects will be handled in the next clause.

7.3.3.1 Differences between BNF - TTCN-3 Type Mapping

In normal cases the mapping is straight forward. Below you find the exceptions, including potential examples.

- The root message type is not a SIP-message but directly a Request or Response type which is represented as a TTCN-3 record. All Method - Message names (INVITE, BYE, ACK etc.) and all message header field names (To, From, CallID, Cseq, Via etc.) are mapped to an enumerated type in TTCN-3 to simplify the extension of new headers. During encoding, the long-form of these message header fields is always used. The respective field in the header type is restricted to values which are allowed.

| BNF rules of RFC | TTCN-3 Type Mapping |
|----------------------------------|---|
| SIP-message = Request / Response | type record REGISTER_Request {...}, type record INVITE_Request {...}, type record PRACK_Request {...}, type record NOTIFY_Request {...}, type record UPDATE_Request {...}, ... type record Response {...} |

| | |
|---|--|
| Method = INVITEm / ACKm / OPTIONSm / BYEm / CANCELm / REGISTERm / ... | type enumerated Method { ACK_E, BYE_E, CANCEL_E, INVITE_E, OPTIONS_E, REGISTER_E, ...} |
|---|--|

- The structure of the message header fields are mapped to a "set" type in TTCN-3, because the order of these header fields is not mandatory. There is an Unknown Header List given in the type system to decode unknown headers with ID and Value.

| | |
|--|---|
| Message-header = (... / Contact / Content-Disposition ... / Via / Warning / WWW-Authenticate / extension-header) CRLF | type set MessageHeader { ... Contact contact optional, ContentDisposition contentDisposition optional, ... Via via, Warning warning optional, WwwAuthenticate wwwAuthenticate optional, UndefinedHeader_List undefinedHeader_List optional } |
|--|---|

- The various parameter lists defined in the BNF are mapped and combined into three different TTCN-3 sets of generic-param types. These types differ only in their name: SemicolonParam_List, AmpersandParam_List, CommaParam_List to distinguish between the relevant separators.

| | |
|--|---|
| Uri-parameters = *(";" uri-parameter) | type set of GenericParam SemicolonParam_List ; |
| Authentication-Info = "Authentication-Info" HCOLON ainfo *(COMMA ainfo) | type record AuthenticationInfo { FieldName fieldName(AUTHENTICATION_INFO_E), CommaParam_List ainfo } |
| ainfo = nextnonce / message-qop / response-auth / cnonce / nonce-count | type set of GenericParam CommaParam_List ; |
| Headers = "?" header *("&" header) | type set of GenericParam AmpersandParam_List ; |

- Any more specific parameter rule (e.g. uri-param, user-param, lr-param, digest-chn, etc.) is simplified to the generic-param rule which will be mapped as a record structure of two charstrings (ID and paramValue). This is equivalent to a token with an optional generic value (token [EQUAL gen-value]).

| | |
|--|--|
| Digest-chn = realm / domain / nonce / opaque / stale / algorithm / qop-options / auth-param | type record GenericParam { charstring id, charstring paramValue optional } |
|--|--|

- In addition to the pure charstring as a base type, the TTCN-3 type system provides base integer types which are unrestricted to the model e.g. the portField, Cseq number, maxForward digit.

| | | |
|------------|---|-------------------|
| User = | 1*(unreserved / escaped / user-unreserved) telephone-subscriber as defined in RFC 2806 | charstring |
| password = | *(unreserved / escaped / "&" / "=" / "+" / "\$" / ", ") | charstring |

| | | |
|---------------|---|----------------|
| Port = | 1*DIGIT | integer |
| Status-Code = | Informational / Redirection / Success / Client-Error / Server-Error / Global-Failure / extension-code | integer |

- Where the same header type can appear multiple times within a message, they will be decoded as a single header field, with multiple list elements. The order of appearance of the headers will be preserved within the header list value.

| | | |
|-----------------|--|---|
| Contact = | ("Contact" / "m") HCOLON (STAR / (contact-param *(COMMA contact-param))) | type record Contact { FieldName fieldName(CONTACT_E), ContactBody contactBody } |
| contact-param = | (name-addr / addr-spec) *(SEMI contact-params) | type record ContactAddress { Addr_Union addressField, SemicolonParam_List contactParams optional } type union ContactBody { charstring wildcard, ContactAddress_List contactAddresses } Used in type set of ContactAddress ContactAddress_List; |

- The BNF (clause 7.3.1 Header Field Format RFC 3261 [16]) specifies that several WWW or Proxy Authentication/Authorization headers should not be combined into a single header; however they will be decoded into such in the codec. If these need to be sent downlink then a new, 'raw' (pure charstring) message type will be introduced.

| | | |
|-----------------|--|--|
| Authorization = | "Authorization" HCOLON credentials | type record Authorization { FieldName fieldName(AUTHORIZATION_E), Credentials body } |
| Credentials = | ("Digest" LWS digest-response) / other-response | type union Credentials { CommaParam_List digestResponse, OtherAuth otherResponse } |

- The different schemes (sip, sips, tel, fax, absoluteUri) in the SIP URI are all handled via the same type definition. The union "UriComponents" can be enhanced to support further specific URI formats. Nevertheless it is possible to use the "other" branch of "UriComponents" for any other URI format in which case the charstring shall contain the URI without the scheme and the first ":".

| | | |
|---------------|--|---|
| Request-URI = | SIP-URI / SIPS-URI / absoluteURI | type record SipUriComponents { // sip-uri acc. To RFC 3261 [16] cl. 19.1 UserInfo userInfo optional, HostPort hostPort } |
| with | | |
| SIP-URI = | "sip:" [userinfo] hostport uri-parameters [headers] | type record TelUriComponents { // tel-uri acc. To RFC 3966 [38] charstring subscriber } |
| and | | type record UrnUriComponents { // urn-uri acc. To RFC 2141 [39] charstring namespaceId, // e.g. "service" charstring namespaceSpecificString // e.g. "sos" } |
| SIPS-URI = | "sips:" [userinfo] hostport uri-parameters [headers] | type union UriComponents { SipUriComponents sip, // scheme: "sip" or sips" TelUriComponents tel, // scheme: "tel" UrnUriComponents urn, // scheme: "urn" charstring other } |
| and | | |
| absoluteURI = | scheme ":" (hier-part / opaque-part) | type record SipUri { { charstring scheme , UriComponents components, SemicolonParam_List urlParameters optional, AmpersandParam_List headers optional }type record SipUri { charstring scheme , UserInfo userInfo optional, HostPort hostPort, SemicolonParam_List urlParameters optional, AmpersandParam_List headers optional } |

- Universal charstrings shall be supported by the codec especially for the Display name in the URI.
- For downlink messages the len field in the ContentLength header is always set to 0 by TTCN; in case of the SIP message containing a message body SS shall replace the value by the actual length of the encoded message body (see clause 7.3.4).
- According to the SIP type definitions there are many 'charstring' fields being optional in records;
⇒ in UL the decoder shall map missing information by setting the respective field to omit rather than by assigning an empty string ("").
- type union Addr_Union
As in 'NameAddr' the field 'displayName' is optional in the first place the two branches of 'Addr_Union' are equivalent when there is no 'displayName'; nevertheless in UL the decoder shall use the branch 'nameAddr' if – and only if – the address information is surrounded by '<' and '>' (what is needed at least when there is a display name followed by the address information)
- Ipv6 address in URI
When an Ipv6 address is used as hostname in a SIP URI it is typically surrounded by '[' and ']' what is matter of the codec: in DL the codec shall add '[' and ']' when needed, in UL the '[' and ']' shall be removed i.e. in the 'host' field of the SipUriComponents' hostPort there shall be no '[' or ']' at the beginning or at the end.

7.3.3.2 URL Encoding

Several fields or parameters in SIP headers require URL encoding (e.g. Contact header, Accept-Contact header). In TTCN there is no encoding rule defined for URL encoding and there is no specific type definition for URL encoded strings. For that reason URL encoding/decoding is not a matter of codec implementation but shall be done in TTCN.

7.3.4 Additional requirements for codec implementations (Message Body)

The message body of a SIP message may contain the message of other protocols (SDP, SMS, etc.) and can be represented e.g. by XML. Therefore the type definitions for these protocols can be TTCN-3 as well as XSD definitions.

As in principle the message body of a SIP message may host any XSD definition, SIP and XSD definitions are decoupled:

To avoid import of all potential XSD definitions the XML body of SIP messages is defined as a charstring. This requires a two-stage encoding and decoding: In DL an XML message needs to be encoded in TTCN first before it gets put in the message body of a SIP message, in UL the XML message contained in the message body needs to be explicitly decoded in TTCN. By defining the XML message body as a charstring the SIP definitions are independent from any XSD definitions and a specific XSD definition needs to be known only when it is really used.

An SDP message may be contained in the message body itself or in a MIME message. In both cases the SDP message is represented as charstring in the SIP message and as for XML a two-stage encoding and decoding is applied in TTCN. This allows explicit fail assignments in case of syntactically incorrect SDP messages when syntactical correctness is a test requirement.

NOTE: Test specifications (e.g. TS 34.229-1 [5]) define the criteria for syntactical correctness and codec implementations follow these criteria.

In detail the message body for SIP messages is defined as:

| |
|---|
| <pre> type charstring XmlBody; type charstring SdpBody; type union MessageBody { SdpBody sdpMessageBody XmlBody xmlBody, MIME_Message mimeMessageBody, charstring sipfrag, charstring textplain, SimpleMsgSummary simpleMsgSummary, octetstring smsMessage }; </pre> |
| <p>NOTE: In contrast to SIP and SDP definitions which are commonly defined by ETSI the definition of the message body is project specific i.e. other IMS test projects at ETSI may use different definitions of the message body.</p> |

7.3.5 Additional requirements for codec implementations (SDP Body)

The Session Description Protocol is defined in RFC 4566.

- The 'type' fields (such as 'v' and 'o' are not represented).
- For the defined attributes, the att-field is also not represented (e.g. 'curr' is not represented in SDP_attribute_curr).
- The Messages which are not of interest to a test suite are left undecoded as a charstring and will not be further structured.

7.3.5.1 Differences between BNF - SDP Type Mapping

In normal cases the mapping is straight forward. Below are the exceptions which differ.

- The numerical fields in the origin-field, the time-field and the timezone field have been defined as charstring because they may not fit into a 32-bit signed integer.

| BNF Rules of RFC 4566 | TTCN 3 Type Mapping |
|--|--|
| origin = username sess-id sess-version nettype addrtype unicast-address | type record SDP_Origin { charstring username, charstring session_id, charstring session_version, charstring net_type, charstring addr_type, charstring addr } |
| time-fields = start-time stop-time repeat-fields [zone-adjustments] | type record SDP_time_field { charstring start_time, charstring stop_time } |
| zone-adjustments = time typed-time | type record SDP_timezone { charstring adjustment_time, SDP_typed_time offset } |

- The zone-adjustments field in the time-fields has been included as an additional field in the top-level message definition.

| BNF Rules of RFC 4566 | TTCN 3 Type Mapping |
|--|---|
| session-description = proto-version origin-field session-name-field information-field uri-field email-fields phone-fields connection-field bandwidth-fields time-fields key-fields attribute-fields media-descriptions | type record SDP_Message { integer protocol_version, SDP_Origin origin, charstring session_name, charstring information optional, charstring uri optional, SDP_email_list emails optional, SDP_phone_list phone_numbers optional, SDP_connection connection optional, SDP_bandwidth_list bandwidth optional, SDP_time_list times, SDP_timezone_list timezone_adjustments optional, SDP_key key optional, SDP_attribute_list attributes optional, SDP_media_desc_list media_list optional } |
| time-fields = start-time stop-time repeat-fields [zone-adjustments] | type record SDP_time { SDP_time_field time_field, SDP_repeat_list time_repeat optional } |

- The mappings for the email-address, phone-number and connection-address fields have been simplified.

| BNF Rules of RFC 4566 | TTCN 3 Type Mapping |
|---|---|
| email-address = address-and-comment / dispname-and-address / addrspec | type record SDP_contact { charstring addr_or_phone, charstring disp_name optional } |
| phone-number = email-safe / email-safe "<" phone ">" / phone | type record SDP_contact { charstring addr_or_phone, charstring disp_name optional } |
| connection-address = multicast-address / unicast-address | type record SDP_conn_addr { charstring addr, integer ttl optional, integer num_of_addr optional } |

7.3.5.2 Defined attributes

The SDP_attribute type is defined as a union of the following attribute types. There is an unknown attribute given to decode undefined attributes with a name and value.

| SDP Attribute | TTCN 3 Type Mapping |
|---------------|--|
| cat | type record SDP_attribute_cat { charstring attr_value } |
| charset | type record SDP_attribute_charset { charstring attr_value } |
| conf | type record SDP_attribute_curr { charstring preconditionType, charstring statusType, charstring direction } |
| curr | type record SDP_attribute_curr { charstring preconditionType, charstring statusType, charstring direction } |
| des | type record SDP_attribute_des { charstring preconditionType, charstring strength, charstring statusType, charstring direction } |
| fmtp | type record SDP_attribute_fmtp { charstring attr_value } |
| framerate | type record SDP_attribute_framerate { charstring attr_value } |
| inactive | type record SDP_attribute_inactive { } |
| keywds | type record SDP_attribute_keywds { charstring attr_value } |
| lang | type record SDP_attribute_lang { charstring attr_value } |
| orient | type record SDP_attribute_orient { charstring attr_value } |
| ptime | type record SDP_attribute_ptime { charstring attr_value } |
| quality | type record SDP_attribute_quality { charstring attr_value } |
| recvonly | type record SDP_attribute_recvonly { } |
| rtcp | type record SDP_attribute_rtcp { charstring attr_value } |
| rtppmap | type record SDP_attribute_rtpmap { charstring attr_value } |
| sdplang | type record SDP_attribute_sdplang { charstring attr_value } |
| sendrecv | type record SDP_attribute_sendrecv { } |
| sendonly | type record SDP_attribute_sendonly { } |
| Tool | type record SDP_attribute_tool { } |

| SDP Attribute | TTCN 3 Type Mapping |
|---------------|---|
| | charstring attr_value } |
| Type | type record SDP_attribute_type { charstring attr_value } |
| Unknown | type record SDP_attribute_tool { charstring name, charstring attr_value optional } |

7.3.6 Additional requirements for codec implementations (HTTP)

For HTTP the same types and header are used as for SIP.

⇒ Rules and requirements are applicable as defined for SIP in clause 7.3.

7.3.7 Additional requirements for codec implementations (XML)

XML data schema is used in IMS conformance testing according to ETSI ES 201 873-9. No further requirements are necessary.

7.4 Requirements for codec implementations (DHCP, DNS)

The DHCP/DNS codec converts TTCN descriptions into/from octet streams as specified in the RFCs. The TTCN type definitions for DHCP/DNS types closely follow the data formats defined in the corresponding RFCs (RFC 1035, RFC 1533, RFC 2131, RFC 3315, RFC 3319 and RFC 3361).

8 Design consideration

8.1 Void

8.2 Void

8.3 Void

8.4 AT commands

All mandatory and optional AT commands are sent as AT command strings as defined above. If an optional AT command is not implemented in the UE, the system adaptor needs to parse the AT command and map it to an appropriate MMI command (which is out of scope for this document).

The following AT commands are applied in TTCN.

Table 8.4-1: AT Commands

| Command |
|-----------|
| AT+CLIP |
| AT+CLIR |
| AT+COLP |
| AT+CCFCU |
| AT+CHLD |
| AT+CDU |
| AT+CHCCS |
| AT+CDEFMP |
| AT+COLR |
| AT+CCWA |
| AT+CNAP |
| AT+CLCK |
| AT+CCMMD |

AT commands are referred to TS 27.007 [49].

8.5 Timer Tolerances

For timers used in conformance test cases according to TS 34.229-1 [5], a tolerance of 10% shall be applied.

8.6 Bearer information for UTRAN

The Radio Access Bearer for IMS signalling is configured according to TS 34.108 [7] clause 6.10.2.4.1.26.

Annex A (normative): Abstract Test Suites (ATS)

This annex contains the approved ATSs.

The ATSs have been produced using the Testing and Test Control Notation version 3 (TTCN3) according to ES 201 873 [12].

A.1 Version of specifications

Table A.1 shows the version of the test specifications which the delivered ATSs are referred to.

Table A.1: Versions of the test and Core specifications

| | |
|----------------------------|-----------------------|
| Core specifications | 3GPP TS 24.229 [11] |
| Test specifications | 3GPP TS 34.229-1 [5] |
| | 3GPP TS 34.229-2 [6] |
| | 3GPP TS 34.123-3 [2] |
| | 3GPP TS 36.523-3 [30] |

A.2 IMS-CC ATS

Table A.2 lists all approved test cases.

Table A.2: IMS-CC TTCN test cases

| Test case | Description |
|-----------|---|
| 6.3 | Dedicated PDP Context Establishment |
| 7.1 | P-CSCF Discovery via PDP Context |
| 8.1 | Initial registration |
| 8.2 | User Initiated Re-Registration |
| 8.3 | Mobile Initiated Deregistration |
| 8.4 | Invalid behaviour- 423 Interval too brief |
| 8.15 | Refresh for ISIM parameters |
| 8.16 | User initiated re-registration- 423 Interval Too Brief |
| 9.1 | Invalid Behaviour – MAC Parameter Invalid |
| 9.2 | Invalid Behaviour – SQN out of range |
| 10.1 | Invalid Behaviour – 503 Service Unavailable |
| 11.1 | Network-initiated deregistration |
| 11.2 | Network initiated re-authentication |
| 12.2 | MO Call – 503 Service Unavailable |
| 12.2a | MO Call – 504 Server Time-out |
| 12.12 | MO MTSI Voice Call Successful with preconditions |
| 12.13 | MT MTSI speech call |
| 12.18 | MTSI MO speech call / SSAC / 0% access probability for MTSI MO speech call |
| 12.19 | MTSI MO video call / SSAC / 0% access probability for MTSI MO video call |
| 12.20 | Emergency call / Success / SSAC / 0% access probability for MTSI MO speech call |
| 12.21 | MO MTSI Video call |
| 12.22 | MT MTSI Video call |
| 12.23 | MO MTSI speech call / EVS |
| 12.24 | MT MTSI speech call / EVS |
| 12.25 | MO MTSI speech call / EVS / AMR-WB |
| 12.26 | MT MTSI speech call / EVS / AMR-WB IO mode |
| 15.1 | Originating Identification Presentation |
| 15.2 | Originating Identification Restriction |
| 15.2a | Originating Identification Restriction / Signalling |
| 15.3 | Terminating Identification Presentation |
| 15.4 | Terminating Identification Restriction |
| 15.4a | Terminating Identification Restriction / Signalling |
| 15.5 | Communication Forwarding unconditional |
| 15.7 | Communication Forwarding on non Reply: activation |
| 15.8 | Communication Forwarding on non reply: MO call initiation |
| 15.9 | Communication Forwarding on Busy |
| 15.10 | Communication Forwarding on Not logged-in |
| 15.10a | Communication Forwarding on Not reachable |
| 15.11 | MO Call Hold without announcement |
| 15.11a | MO Video Call Hold without announcement |
| 15.12 | MT Call Hold without announcement |
| 15.12a | MT Video Call Hold without announcement |
| 15.13 | Incoming Communication Barring except for a specific user |
| 15.14a | Communication barring while roaming |
| 15.14b | Outgoing Communication Barring while roaming |
| 15.15 | Subscription to the MWI event package |
| 15.17 | Creating a conference |
| 15.19 | Inviting user to conference by sending a REFER request to the conference focus |
| 15.19a | Inviting user to conference by sending a REFER request to the conference focus / Video |
| 15.21a | Three way session creation |
| 15.21c | Three way session creation / Video |
| 15.27 | Communication Waiting and answering the call |
| 15.28 | Communication Waiting and cancelling the call |
| 15.29 | GBA authentication |
| 16.2 | Speech AMR, indicate selective codec modes |
| 16.3 | Speech AMR-WB, indicate all codec modes |
| 16.4 | Speech AMR-WB, indicate selective codec modes |
| 17.1 | MO Speech, add video remove video |
| 17.2 | MT Speech, add video remove video |
| 18.1 | Mobile Originating SMS |
| 18.2 | Mobile Terminating SMS |
| 19.1.2 | Emergency call with emergency registration / Success / Location information not available |

| | |
|---------|---|
| 19.1.3 | Emergency call with emergency registration / Abnormal case / IM CN sends a 380 / UE performs emergency call via CS domain / UTRAN or GERAN |
| 19.1.5 | Emergency call with emergency registration / Emergency SIP signalling and media in parallel with an other ongoing IM CN subsystem signalling and media |
| 19.3.1 | Non-UE detectable emergency call / IM CN sends a 1xx response / UE geographical location information available |
| 19.3.2 | Non-UE detectable emergency call / IM CN sends 380 Alternative Service including emergency service URN and no emergency subservice type / Non-emergency IMS registration / UTRAN or GERAN |
| 19.3.2b | Non-UE detectable emergency call / IM CN sends a 380 with unavailable emergency service URN / UE performs normal call via CS domain / UTRAN or GERAN |
| 19.3.2c | Non-UE detectable emergency call / IM CN sends a 380 with available emergency service URN / UE performs CS Emergency call via CS domain / UTRAN or GERAN |
| 19.3.3 | Non-UE detectable emergency call / IM CN sends 380 Alternative Service / Emergency IMS registration |
| 19.3.4 | Non-UE detectable emergency call / IM CN sends 380 with an Alternative Service / Previous emergency IMS registration not expired |
| 19.4.1 | Emergency call without emergency registration / EPS / UE does not contain an ISIM or USIM |
| 19.4.2 | Emergency call without emergency registration / EPS / UE contains an ISIM or USIM / UE is in state EMM-REGISTERED.LIMITED-SERVICE |
| 19.4.5 | Emergency call without emergency registration / UE credentials are not accepted |
| 19.4.6 | Emergency call without emergency registration / Failure of registration / Rejected by 403(Forbidden) |
| 19.4.7 | Emergency call without emergency registration / Failure of registration / against a network with GIBA support only |
| 19.5.1 | New initial emergency registration / UE obtains from the serving IP-CAN an IP address different than the IP address used for the emergency registration |
| 19.5.6 | User-initiated emergency reregistration / UE has emergency related ongoing dialog |
| 19.5.7 | User-initiated emergency reregistration / The user initiates an emergency call |
| 19.5.8 | User-initiated emergency reregistration / Standalone transactions exist |
| 19.5.9 | In parallel emergency and non-emergency registrations |
| 19.5.10 | Deregistration upon emergency registration expiration |
| 20.1 | Mobile Originating CAT – Forking Model |
| G.8.1 | Initial Registration / WLAN |

The Test Suite in TTCN3 is contained in multiple ASCII files which accompany the present document.

A.2.1 Void

A.2.2 Void

A.2.3 Void

Annex B (normative): Partial IXIT proforma

Notwithstanding the provisions of the copyright related to the text of the present document, The Organizational Partners of 3GPP grant that users of the present document may freely reproduce the partial IXIT proforma in this annex so that it can be used for its intended purposes and may further publish the completed partial IXIT.

B.0 Introduction

This partial IXIT proforma contained in the present document is provided for completion, when the related Abstract Test Suite is to be used against the Implementation Under Test (IUT).

Text in *italics* is comments for guidance for the production of an IXIT, and is not to be included in the actual IXIT.

The completed partial IXIT will normally be used in conjunction with the completed ICS, as it adds precision to the information provided by the ICS.

B.1 Parameter values

B.1.1 PIXITs

Table B.1.1: PIXIT

| Parameter name | Description | Type | Default value | Supported value |
|---------------------------------|--|------------|--|---|
| px_IMS_AssociatedTelUri | TEL URI for the user | charstring | " +331234567 " | format shall be TEL URI |
| px_IMS_CalleeUri | URI of Callee, send by the UE in INVITE (MO call establishment) to address the remote UE | charstring | "sip:User-B@3gpp.org" | |
| px_IMS_CalleeUri2 | URI of Callee, sent by the UE in INVITE (MO call establishment) to address the remote UE | charstring | " sip:User-C@3gpp.org " | |
| px_IMS_CalleeContactUri | URI provided by the remote side (i.e. by SS) to be used by the UE as contact address in further SIP signalling of the dialog NOTE: in general this URI shall be different than the one in px_CalleeUri | charstring | "sip:User-B-Contact@3gpp.org" | |
| px_IMS_CalleeContactUri2 | URI provided by the remote side (i.e. by SS) to be used by the UE as contact address in further SIP signalling of the dialog NOTE: in general this URI shall be different than the one in px_CalleeUri2 | charstring | "sip:User-C-Contact@3gpp.org" | |
| px_IMS_CiphAlgo_Def | Ciphering Algorithm; NOTE: Unless specified otherwise in the test prose „nociph“ shall not be used for verification | CiphAlgo | des_edes3_cbc | enumerated type: des_edes3_cbc, aes_cbc or nociph |
| px_IMS_HomeDomainName | Home Domain Name. Applicable when using an ISIM: same value as EF _{DOMAIN} . (derived from the IMSI otherwise) FBBA: value as preconfigured at the UE | charstring | As defined in TS 34.229-1 [5], Annex E | |
| px_IMS_HomeDomainName_Refreshed | used in 8.15 | charstring | "refreshed3gpp.org" | |
| px_IMS_Private_UserId_Refreshed | used in 8.15 | charstring | "privateuser@refreshed3gpp.org" | |

| Parameter name | Description | Type | Default value | Supported value |
|--------------------------------------|--|------------|---|---|
| px_IMS_PublicUserIdentity1_Refreshed | used in 8.15 | charstring | "sip:PublicId1@refreshed3gpp.org" | |
| px_IMS_MessageAccountIdentity | used in 15.15 | charstring | "" | |
| px_IMS_SPI_ValidValueList_PDN1 | List of comma separated integer values that can be used as SPI values for IMS security on PDN1; each value shall be ≥ 256 | charstring | "" | |
| px_IMS_SPI_ValidValueList_PDN2 | List of comma separated integer values that can be used as SPI values for IMS security on PDN2; each value shall be ≥ 256 | charstring | "" | |
| px_IMS_IPSecAlgorithm | Integrity Algorithm | IntAlgo | hmac_sha_1_96 | enumerated type; hmac_md5_96, hmac_sha_1_96 |
| px_IMS_Private_UserId | Private User Identity. Applicable when using an ISIM: same value as EF _{IMPI} . (derived from the IMSI otherwise) FBBA: username as used for authorization | charstring | As defined in TS 34.229-1 [5], Annex E | |
| px_IMS_PublicUserIdentity1 | Public User Identity. It is set to the same value as the first record in EF _{IMPU} . FBBA: IMPU preconfigured in the UE | Charstring | As defined in TS 34.229-1 [5], Annex E | |
| px_IMS_PublicUserIdentity2 | It is set to the same value as the second record in EF _{IMPU} . | Charstring | As defined in TS 34.229-1 [5], Annex E | |
| px_IMS_PublicUserIdentity3 | It is set to the same value as the third record in EF _{IMPU} . | Charstring | As defined in TS 34.229-1 [5], Annex E | |
| px_SMS_SMSC_InternationalNumber | international number of the SMSC: Dialed number string of the TS-Service Centre Address according to clause 4.5.3.9 "EFSMSP (Short message service parameters)" in TS 31.121 [52] (TON is assumed to be "International Number"). | charstring | As defined in Annex E.3.2.14 of TS 34.229-1 [5]: "112233445566778" according to TS 31.121 [52]. | |
| px_UEwithISIM | true: UE has ISIM false: UE has USIM only | boolean | true | |
| px_DigestPasswordForXCAP | XCAP password | charstring | "XCAP-Password" | |
| px_DigestPasswordForSIP | SIP password | charstring | "SIP-Password" | |
| px_XCAP_RootUri | XCAP Root URI according to section 6.1 of RFC 4825 [70] as configured at the UE | charstring | "/XCAP.3gpp.org" | |
| px_XCAP_TargetUri | Target (SIP or TEL URI) where to forward to | charstring | "sip:user@domain.com" | |
| px_XCAP_Username | username to be used for HTTP authentication in case of pc_XCAP_UsernameIsConfiguredInUE == true | charstring | | |

B.2 MMI Commands

In addition to the MMI commands defined in TS 36.523-3 clause 5 there are further MMI commands for IMS:

Table B.2.1-1: MMI commands

| Command | Parameters | |
|------------------------------------|------------|----------------|
| | Name | Value |
| "DEREGISTER" | (none) | |
| "ACCEPT_MTSI_TEXT" | (none) | |
| "ACTIVATE_MESSAGE_WAIT_INDICATION" | (none) | |
| "TRIGGER_SMS" | (none) | |
| "TRIGGER_2ND_IMPU" | (none) | |
| "TRIGGER_3RD_IMPU" | (none) | |
| "REFRESH" | "Uri" | <Callee's URI> |
| " INVITE_TO_CONFERENCE" | "Uri" | <Refer-To Uri> |
| "IMS_INITIATE_CONFERENCE" | (none) | |
| "ACTIVATE_IMS_TIR" | (none) | |
| "DEACTIVATE_IMS_TIR" | (none) | |

Annex C: Void

Annex D: Void

Annex E (informative): TTCN3 style guide for 3GPP IMS ATS

For IMS conformance tests, the style guide of 36.523-3[30], Annex B shall be applied

Annex F (informative): BNF Message Definitions

The BNF definitions required for the ATS are defined in the following RFCs:

3261, 3262, 3265, 3311, 3313, 3323, 3325, 3326, 3327, 3329, 3428, 3455, 3515, 3608, 3840, 3841, 3891, 3892, 3903, 3911, 4028.

Annex G (Normative): SIP Type Definitions and XSD References

The XSD references listed in this Annex are imported in the Test Suite.

Common Definitions

| XML Schema | Source | Name space | Modifications |
|-----------------------------|-----------------------------------|--|--|
| reginfo | RFC 3680 [24] | urn:ietf:params:xml:ns:reginfo | |
| conference-info | RFC 4575 [45] | urn:ietf:params:xml:ns:conference-info | |
| gruuinfo | RFC 5628 [46] | urn:ietf:params:xml:ns:gruuinfo | |
| AlternativeService | TS 24.229 [11] Table 7.6.1 | NoTargetNamespace | |
| pdfif | RFC 3863 [47] | urn:ietf:params:xml:ns:pdfif | definitions modified according to errata id 1606 |
| pdfif_geopriv10 | RFC 4119 [44] | urn:ietf:params:xml:ns:pdfif:geopriv10 | NOTE: RFC's errata has no impact on definitions |
| pdfif_geopriv10_basicPolicy | RFC 4119 [44] | urn:ietf:params:xml:ns:pdfif:geopriv10:basicPolicy | NOTE: RFC's errata has no impact on definitions |
| pdfif_geopriv10_civicLoc | RFC 4119 [44] | urn:ietf:params:xml:ns:pdfif:geopriv10:civicLoc | NOTE: RFC's errata has no impact on definitions |
| SRVCC | TS 24.237 [51] Annex D.2 | NoTargetNamespace | |
| xml | http://www.w3.org/2001/03/xml.xsd | http://www.w3.org/XML/1998/namespace | |

XCAP specific definitions

| XML Schema | Source | Name space |
|-----------------------|----------------|--|
| 24604 | TS 24.604 [40] | http_uri_etsi_org_ngn_params_xml_simservs_xcap |
| OIP-OIR | TS 24.607 [41] | http_uri_etsi_org_ngn_params_xml_simservs_xcap |
| TIP-TIR R2 | TS 24.608 [42] | http_uri_etsi_org_ngn_params_xml_simservs_xcap |
| 24611 | TS 24.611 [43] | http_uri_etsi_org_ngn_params_xml_simservs_xcap |
| XCAP | TS 24.623 [36] | http_uri_etsi_org_ngn_params_xml_simservs_xcap |
| xdm_commonPolicy-V1_0 | | urn_oma_xml_xdm_common_policy |
| common-policy | RFC 4745 [48] | urn_ietf_params_xml_ns_common_policy |

GBA specific definitions

| XML Schema | Source | Name space |
|------------|----------------|--------------|
| 24109 | TS 24.109 [33] | uri_3gpp_gba |

Additionally the Test Suite imports the following modules of ETSI's LibSip (ETSI SIP Library, see):

| Module | Revision |
|------------------------------|---------------|
| LibSip_Common | LibSip v3.0.2 |
| LibSip_SDPTypes | LibSip v3.0.2 |
| LibSip_SimpleMsgSummaryTypes | LibSip v3.0.2 |
| LibSip_SIPTypesAndValues | LibSip v3.0.2 |

The LibSip module LibSip_MessageBodyTypes (imported by LibSip_SIPTypesAndValues) contains type definitions for the message body of SIP messages which in general are project specific. For 3GPP conformance testing LibSip_MessageBodyTypes is defined as shown below.

G.1 LibSip_MessageBodyTypes

G.1.1 MIMETypes

MIME_Encapsulated_Parts

| TTCN-3 Union Type | | |
|-------------------|-------------------------|----------------------|
| Name | MIME_Encapsulated_Parts | |
| Comment | | |
| sdpMessageBody | SdpBody | |
| xmlBody | XmlBody | if there is XML body |

MIME_Encapsulated_Part

| TTCN-3 Record Type | | | |
|------------------------|---|-----|--|
| Name | MIME_Encapsulated_Part | | |
| Comment | | | |
| content_type | charstring | | |
| content_disposition | charstring | opt | |
| mime_encapsulated_part | MIME_Encapsulated_Parts | | |

MIME_Message

| TTCN-3 Record Type | | | |
|----------------------|--------------------------------------|--|------|
| Name | MIME_Message | | |
| Comment | | | |
| boundary | charstring | | len: |
| mimeEncapsulatedList | MimeEncapsulatedList | | |

MimeEncapsulatedList

| TTCN-3 Record of Type | |
|-----------------------|--|
| Name | MimeEncapsulatedList |
| Comment | |
| | record of MIME_Encapsulated_Part |

LibSip_MessageBodyTypes: Basic Type Definitions

| TTCN-3 Basic Types | | |
|--------------------|------------|--|
| XmlBody | charstring | |
| SdpBody | charstring | |

MessageBody

| TTCN-3 Union Type | | |
|-------------------|------------------------------|--|
| Name | MessageBody | |
| Comment | | |
| sdpMessageBody | SdpBody | if there is only SDP part |
| xmlBody | XmlBody | if there is XML body |
| mimeMessageBody | MIME Message | if there is SDP and encapsulated ISUP part |
| sipfrag | charstring | if content-Type is message/sipfrag (cp. NOTIFY, cp TS124147 A.4.3.1.2) |
| textplain | charstring | if content type is text/plain (for testing long messages) |
| simpleMsgSummary | SimpleMsgSummary | RFC 3842 |
| smsMessage | octetstring | encoded SMS message 3GPP 23.040, 24.011 |

G.2 References to TTCN-3

| References to TTCN-3 | | |
|--------------------------------|---|-----------|
| LibSip_MessageBodyTypes | IMS_LibSip/LibSip_MessageBodyTypes.ttcn | Rev 12255 |

Annex H (informative): TTCN-3 Definitions of Common Interfaces

The multi-testers model according to clause 5 provides interfaces which can be re-used by implementations of the IP-CAN test model according to TS 34.229-4 [50].

NOTE: Common type definitions are according to annex D of TS 36.523-3 [30].

H.1 IMS_PTC_CoordMsg

IMS_TestProcedure_Type

| TTCN-3 Enumerated Type | |
|------------------------------------|---|
| Name | IMS_TestProcedure_Type |
| Comment | |
| IPCAN_InitialRegistration | EUTRA/EPS signalling acc. to 36.508 cl. 4.5.2.3 without RRC Connection Release at the end of the procedure NOTE: As working assumption the UE does IMS REGISTRATION automatically after RRC/NAS registration |
| IPCAN_EmergencyCall_NormalService | EUTRA/EPS signalling acc. to 36.508 cl. 4.5A.4.3 |
| IPCAN_EmergencyCall_LimitedService | EUTRA/EPS signalling acc. to 36.508 cl. 4.5A.5.3 |
| IPCAN_MO_SpeechCall | EUTRA/EPS signalling acc. to 36.508 cl. 4.5A.6.3 |
| IPCAN_MT_SpeechCall | EUTRA/EPS signalling acc. to 36.508 cl. 4.5A.7.3 |
| IPCAN_MO_VideoCall | EUTRA/EPS signalling acc. to 36.508 cl. 4.5A.8.3 |
| IPCAN_MT_VideoCall | EUTRA/EPS signalling acc. to 36.508 cl. 4.5A.9.3 |
| IPCAN_MO_AddVideo | EUTRA/EPS signalling acc. to 36.508 cl. 4.5A.11.3 |
| IPCAN_MT_AddVideo | EUTRA/EPS signalling acc. to 36.508 cl. 4.5A.12.3 |
| IPCAN_ReleaseVideo | EUTRA/EPS signalling acc. to 36.508 cl. 4.5A.15.3 |
| IPCAN_MO_IMS_Signalling | EUTRA/EPS signalling acc. to 36.508 cl. 4.5.3.3 with m = n = 0; used e.g. for MT SMS test case 18.2 |
| IPCAN_MT_IMS_Signalling | EUTRA/EPS signalling acc. to 36.508 cl. 4.5.3.3 Steps 3 to 9 with m = n = 0; used e.g. for MT SMS test case 18.1 |
| IPCAN_XCAP_Signalling | EUTRA/EPS signalling acc. to 36.508 cl. 4.5A.14 |

IMS_TestConfiguration_Type

| TTCN-3 Enumerated Type | |
|------------------------------|--|
| Name | IMS_TestConfiguration_Type |
| Comment | |
| IPCAN_SignallingOnly | EUTRA: default DRB is used only |
| IPCAN_SpeechCall | EUTRA: one dedicated UM bearer; for normal speech calls and emergency call for limited services |
| IPCAN_VideoCall | EUTRA: two dedicated UM bearers |
| IPCAN_EmergencyCall | EUTRA: second default bearer (AM) and one dedicated UM bearer |
| IPCAN_SpeechAndEmergencyCall | EUTRA: default bearer + dedicated bearer for normal speech call and another default bearer + dedicated bearer for emergency call |
| IPCAN_XCAP | EUTRA: second default bearer (AM) for second PDN used for XCAP signalling |

IPCAN_INFO_Type

| TTCN-3 Record Type | | | |
|--------------------|-----------------|-----|--|
| Name | IPCAN_INFO_Type | | |
| Comment | | | |
| RanType | IPCAN_RAN_Type | opt | |
| UE_Release | integer | opt | |
| AuthResLength | integer | opt | |

IMS_IPCAN_CommandName_Type

| TTCN-3 Enumerated Type | |
|----------------------------------|--|
| Name | IMS_IPCAN_CommandName_Type |
| Comment | |
| IPCAN_INIT | trigger the IPCAN_PTC to create a cell and do further appropriate initialisation; which RAN technology to be use is decided by the IPCAN_PTC based on PIXITs; as test procedure shall be specified which procedure is used during the test body to know which DRBs need to be pre-configured; IPCAN returns response indicating the RAN type |
| IPCAN_STARTPROCEDURE | trigger the IPCAN to expect (MO) or page (MT) the UE to establish an RRC connection; depending on the connection type triggers may need to be sent from IPCAN to IMS or from IMS to IPCAN to synchronise establishment of dedicated DRBs (EUTRA) or secondary PDP contexts (UTRAN) |
| IPCAN_ENDPROCEDURE | trigger RRC connection release by the IPCAN_PTC; as a SIP message may be sent out just before end of the procedure in general a delay of 2s shall be added before sending IPCAN_ENDPROCEDURE to IPCAN; for UTRAN it is up to IPCAN and SS implementation to cope with possible/necessary release of (secondary) PDP context; a trigger shall be sent from IPCAN to IMS to indicate when RRC connection is released |
| IPCAN_RELEASE | Detach UE and release cell (postamble); a trigger is shall be sent from IPCAN to IMS to indicate when IPCAN is released |
| IPCAN_QUERY | query information from the IPCAN PTC |
| IPCAN_PROVIDELOCATIONINFORMATION | trigger IPCAN to provide UELocationInformation to the UE acc. to 36.509 |

IMS_IPCAN_Command_Type

| TTCN-3 Record Type | | | |
|--------------------|--|-----|--|
| Name | IMS_IPCAN_Command_Type | | |
| Comment | Messages IMS_PTC -> IPCAN | | |
| Name | IMS_IPCAN_CommandName_Type | | |
| TestConfiguration | IMS_TestConfiguration_Type | opt | |
| TestProcedure | IMS_TestProcedure_Type | opt | |

IMS_IPCAN_ResponseName_Type

| TTCN-3 Enumerated Type | |
|------------------------|--|
| Name | IMS_IPCAN_ResponseName_Type |
| Comment | |
| IPCAN_INIT | response for INIT command: carries the RAN type as used by the IPCAN PTC; the RAN type depends on PIXIT settings: part 4 model: px_RANTech part 3 model: EUTRA_FDD or EUTRA_TDD depending on px_ePrimaryFrequencyBand (px_ePrimaryFrequencyBand < 33 => FDD) |
| IPCAN_QUERY | |

IPCAN_IMS_Response_Type

| TTCN-3 Record Type | | | |
|--------------------|---|-----|--|
| Name | IPCAN_IMS_Response_Type | | |
| Comment | | | |
| Name | IMS_IPCAN_ResponseName_Type | | |
| IpcanInfo | IPCAN_INFO_Type | opt | |

IPCAN_IMS_Control_Type

| TTCN-3 Union Type | | |
|---------------------|------------------------|--|
| Name | IPCAN_IMS_Control_Type | |
| Comment | | |
| Reset | Null_Type | to reset IMS after UE has been switched off and gets switched on again |
| IpcanInd | Null_Type | to indicate to IMS which IPCAN is active (at port IPCAN or at port OtherIPCAN) |
| ReregistrationStart | IPCAN_RAN_Type | to prepare IMS PTC for (optional) re-registration |
| ReregistrationStop | Null_Type | to indicate to IMS PTC that no re-registration will happen anymore |

IMS_IPCAN_Coordination_MSG

| TTCN-3 Union Type | | |
|-----------------------|---|--|
| Name | IMS_IPCAN_Coordination_MSG | |
| Comment | | |
| TriggerEvent | Null_Type | any trigger of confirmation |
| AbortEvent | Null_Type | sent instead of TriggerEvent if procedure shall be aborted |
| IPCAN_IMS_Control | IPCAN_IMS_Control_Type | IMS <- IPCAN: to control IMS (default behaviour) |
| IMS_IPCAN_Command | IMS_IPCAN_Command_Type | IMS -> IPCAN: command from the IPCAN to control IMS (mainly for IMS default behaviour) |
| IPCAN_IMS_Response | IPCAN_IMS_Response_Type | IMS <- IPCAN: response for previous command |
| ProtocolConfigOptions | NAS_ProtocolConfigOptions_Type | IMS <-> IPCAN: PCOs to be used in NAS signalling |
| IPCAN_IMS_Data | charstring | IMS <- IPCAN: to send data from IPCAN to IMS |

IMS_IPCAN_CO_ORD_PORT

| TTCN-3 Port Type | | |
|------------------|--|--|
| Name | IMS_IPCAN_CO_ORD_PORT | |
| Comment | | |
| out | IMS_IPCAN_Coordination_MSG | |
| in | IMS_IPCAN_Coordination_MSG | |

H.2 IMS_ASP_TypeDefs

IMS_ASP_TypeDefs: Basic Type Definitions

| TTCN-3 Basic Types | | |
|------------------------------------|--------------|--|
| IMS_Request_Type | RequestUnion | Alias for "RequestUnion" as defined in LibSip_SIPTypesAndValues |
| IMS_Response_Type | Response | Alias for "Response" as defined in LibSip_SIPTypesAndValues |
| IMS_PortsAndSecurityConfigCnf_Type | Null_Type | SPIs and protected ports are fully controlled by the IMS PTC => it is not necessary anymore to return IMS_ProtectedPorts_Type, IMS_SPIs_Type to the IMS PTC |

IMS_SecurityContextEnum_Type

| TTCN-3 Enumerated Type | |
|------------------------|------------------------------|
| Name | IMS_SecurityContextEnum_Type |
| Comment | |
| unprotected | |
| protectedContext1 | |
| protectedContext2 | |

IMS_RoutingInfo_Type

| TTCN-3 Record Type | | | |
|--------------------|--|-----|---|
| Name | IMS_RoutingInfo_Type | | |
| Comment | | | |
| Protocol | InternetProtocol_Type | | UDP or TCP |
| Security | IMS_SecurityContextEnum_Type | opt | protected or unprotected (in DL omit when IP PTC shall decide what to do) |
| UE_Address | IP_AddrInfo_Type | opt | sent by the IP PTC when there is an initial request on unprotected connection |
| NW_Address | IP_AddrInfo_Type | opt | sent by the IP PTC when there is an initial request on unprotected connection |

IMS_DATA_REQ

| TTCN-3 Record Type | | | |
|--------------------|--------------------------------------|--|--|
| Name | IMS_DATA_REQ | | |
| Comment | | | |
| RoutingInfo | IMS_RoutingInfo_Type | | |
| Request | IMS_Request_Type | | |

IMS_DATA_RSP

| TTCN-3 Record Type | | | |
|--------------------|--------------------------------------|--|--|
| Name | IMS_DATA_RSP | | |
| Comment | | | |
| RoutingInfo | IMS_RoutingInfo_Type | | |
| Response | IMS_Response_Type | | |

IMS_ProtectedPorts_Type

| TTCN-3 Record Type | | | |
|--------------------|--------------------------------|--|----------------------|
| Name | IMS_ProtectedPorts_Type | | |
| Comment | | | |
| Port_us | PortNumber_Type | | UE side: Server |
| Port_uc | PortNumber_Type | | UE side: Client |
| Port_ps | PortNumber_Type | | network side: Server |
| Port_pc | PortNumber_Type | | network side: Client |

IMS_SPIs_Type

| TTCN-3 Record Type | | | |
|--------------------|----------------------|-----|---|
| Name | IMS_SPIs_Type | | |
| Comment | | | |
| SPI_us | IPsec_SPI_Type | | SPI at UE side: assigned by the UE |
| SPI_uc | IPsec_SPI_Type | | SPI at UE side: assigned by the UE |
| SPI_ps | IPsec_SPI_Type | opt | SPI at network side: to be assigned by TTCN |
| SPI_pc | IPsec_SPI_Type | opt | SPI at network side: to be assigned by TTCN |

IMS_SecurityInfo_Type

| TTCN-3 Record Type | | | |
|--------------------|---|--|--|
| Name | IMS_SecurityInfo_Type | | |
| Comment | | | |
| ProtectedPorts | IMS_ProtectedPorts_Type | | |
| SPIs | IMS_SPIs_Type | | |
| IntegrityAlgorithm | IPsec_IntegrityAlgorithm_Type | | |
| CipheringAlgorithm | IPsec_CipheringAlgorithm_Type | | |

IMS_RegistrationInfo_Type

| TTCN-3 Record Type | | | |
|--------------------|---------------------------------------|-----|--|
| Name | IMS_RegistrationInfo_Type | | |
| Comment | | | |
| NW_Address | IP_AddrInfo_Type | | network address of the chosen IMS server (e.g. IPv4, IPv6) |
| UE_Address | IP_AddrInfo_Type | | UE address as used for security protected connections |
| SecurityInfo | IMS_SecurityInfo_Type | opt | omit in case of GIBA |

IMS_PortsAndSecurityConfigReq_Type

| TTCN-3 Record Type | | | |
|--------------------|---|-----|------------------|
| Name | IMS_PortsAndSecurityConfigReq_Type | | |
| Comment | | | |
| UnprotectedPort_us | PortNumber_Type | opt | 5060 per default |
| RegistrationInfo | IMS_RegistrationInfo_Type | opt | |

IMS_CONFIG_REQ

| TTCN-3 Union Type | | |
|------------------------|--|--|
| Name | IMS_CONFIG_REQ | |
| Comment | | |
| InstallKey | IPsec_SecurityKeys_Type | |
| PortsAndSecurityConfig | IMS_PortsAndSecurityConfigReq_Type | |
| SecurityRelease | Null_Type | |
| RegInfoRelease | Null_Type | |
| CloseTCP | Null_Type | |

IMS_CONFIG_CNF

| TTCN-3 Union Type | | |
|------------------------|--|--|
| Name | IMS_CONFIG_CNF | |
| Comment | | |
| InstallKey | Null_Type | |
| PortsAndSecurityConfig | IMS_PortsAndSecurityConfigCnf_Type | |
| SecurityRelease | Null_Type | |
| RegInfoRelease | Null_Type | |
| CloseTCP | Null_Type | |

IMS_IP_CTRL_PORT

| TTCN-3 Port Type | | |
|------------------|---|--|
| Name | IMS_IP_CTRL_PORT | |
| Comment | Control port at the IMS PTC to configure IP for IMS | |
| out | IMS_CONFIG_REQ | |
| in | IMS_CONFIG_CNF | |

IMS_IP_CLIENT_PORT

| TTCN-3 Port Type | | |
|------------------|---|--|
| Name | IMS_IP_CLIENT_PORT | |
| Comment | IMS client: send requests, receive response | |
| out | IMS_DATA_REQ | |
| in | IMS_DATA_RSP | |

IMS_IP_SERVER_PORT

| TTCN-3 Port Type | | |
|------------------|---|--|
| Name | IMS_IP_SERVER_PORT | |
| Comment | IMS server: send response, receive requests | |
| out | IMS_DATA_RSP | |
| in | IMS_DATA_REQ | |

H.3 HTTP_ASP_TypeDefs

H.3.1 HTTP_ASP_Definitions

HttpServerInfo_Type

| TTCN-3 Record Type | | | |
|--------------------|---------------------|-----|--|
| Name | HttpServerInfo_Type | | |
| Comment | | | |
| serverAddr | IP_AddrInfo_Type | | IP address of simulated server |
| serverPort | PortNumber_Type | | Port number of simulated server |
| drbInfo | IP_DrbInfo_Type | | DRB info as used by the IP PTC (LTE model, see TS 36.523-3 [30]) |
| tlsInfo | TLSInfo_Type | opt | TLS parameters as used by the IP PTC (LTE model, see TS 36.523-3 [30]) (omit: no TLS) |

HttpServerList_Type

| TTCN-3 Record of Type | |
|--|---------------------|
| Name | HttpServerList_Type |
| Comment | |
| record length (1 .. infinity) of HttpServerInfo_Type | |

HTTP_CTRL_REQ

| TTCN-3 Record Type | | | |
|--------------------|--|-----|---|
| Name | HTTP_CTRL_REQ | | |
| Comment | ASP type to configure the http layer; when any of the optional fields is omitted the previous configuration of this field is kept | | |
| httpServerList | HttpServerList_Type | opt | IP address and port of simulated HTTP servers |

HTTP_CTRL_CNF

| TTCN-3 Record Type | | | |
|--------------------|-----------------------------------|-----|----------------------------------|
| Name | HTTP_CTRL_CNF | | |
| Comment | ASP type to confirm HTTP_CTRL_REQ | | |
| errorInfo | charstring | opt | string indicating a system error |

HTTP_DATA_IND

| TTCN-3 Record Type | | | |
|--------------------|---|--|--|
| Name | HTTP_DATA_IND | | |
| Comment | ASP type for sending a message from the http layer to TTCN; it transports relevant information of a http Request from the UE to the Tester | | |
| routingInfo | IP_Connection_Type | | TCP connection from which the request has been received; => response shall use the same |
| httpRequest | HttpRequest_Type | | |

HttpRequest_Type

| TTCN-3 Record Type | | | |
|--------------------------|--------------------------------------|-----|---|
| Name | HttpRequest_Type | | |
| Comment | | | |
| requestLine | HttpRequestLine_Type | | RFC 2616 clause 5.1 |
| userAgent | UserAgent | opt | User Agent according to RFC 2616 [27] clause 14.43 |
| authorization | Authorization | opt | Authorization according to RFC 2616 [27] clause 14.8 (optional; NOTE: Same type definition as for SIP type definitions) |
| host | Host | opt | host according to RFC 2616 [27] clause 14.23 |
| contentType | ContentType | opt | Content-Type according to RFC 2616 [27] clause 14.17 (optional, NOTE: Same type definition as for SIP type definitions) |
| x3GPPIntend dIdentity | charstring | opt | 3GPP TS 24.109 [33] clause G.2 |
| messageBody | charstring | opt | e.g. XCAP Message |

HttpResponse_Type

| TTCN-3 Record Type | | | |
|------------------------|-------------------------------------|-----|--|
| Name | HttpResponse_Type | | |
| Comment | | | |
| statusLine | HttpStatusLine_Type | | Status-Line in RFC 2616 [27] clause 6.1 |
| date | Date | opt | Date according to RFC 2616 [27] clause 14.18 |
| eTag | SIP_ETag | opt | ETag according to RFC 2616 [27] clause 14.19 |
| server | Server | opt | Server according to RFC 2616 [27] clause 14.38 |
| wwwauthentic ate | WwwAuthenticate | opt | WWW-Authenticate in RFC 2616 [27] clause 14.47 (NOTE: Same type definition as for SIP type definitions) |
| authenticationI nfo | AuthenticationInfo | opt | Authentication-Info in RFC 2617 [37] clause 3.2.3 (NOTE: Same type definition as for SIP type definitions) |
| contentType | ContentType | opt | Content-Type in RFC 2616 [27] clause 14.17 (NOTE: Same type definition as for SIP type definitions) |
| contentLength | ContentLength | opt | Content-Length in RFC 2616 [27] clause 14.13 (NOTE: Same type definition as for SIP type definitions) |
| expires | Expires | opt | Expires in RFC 2616 [27] clause 14.21 (NOTE: Same type definition as for SIP type definitions) |
| messageBody | charstring | opt | e.g. XCAP Message (XML document or XML fragment) |

HTTP_DATA_REQ

| TTCN-3 Record Type | | | |
|--------------------|---|--|---|
| Name | HTTP_DATA_REQ | | |
| Comment | ASP type for sending messages from TTCN to the http layer; it transports information needed by the http layer to generate a http Response to the UE | | |
| routingInfo | IP_Connection_Type | | TCP connection to be used in DL: shall be the same as for corresponding request |
| httpResponse | HttpResponse_Type | | |

HttpRequestLine_Type

| TTCN-3 Record Type | | | |
|--------------------|--|--|---|
| Name | HttpRequestLine_Type | | |
| Comment | request line according to RFC 2616 [27] clause 5.1 | | |
| method | charstring | | |
| uri | charstring | | XCAP: selection expression, RFC 4825 [26] |
| version | charstring | | |

HttpStatusLine_Type

| TTCN-3 Record Type | | | |
|--------------------|---|--|--|
| Name | HttpStatusLine_Type | | |
| Comment | status line according to RFC 2616 [27] clause 5.1 | | |
| version | charstring | | |
| code | integer | | |
| reasonPhrase | charstring | | |

H.3.2 HTTP_Port_Definitions**HTTP_CTRL_PORT**

| TTCN-3 Port Type | | | |
|------------------|-------------------------------|--|--|
| Name | HTTP_CTRL_PORT | | |
| Comment | | | |
| out | HTTP_CTRL_REQ | | |
| in | HTTP_CTRL_CNF | | |

HTTP_DATA_PORT

| TTCN-3 Port Type | | | |
|------------------|-------------------------------|--|--|
| Name | HTTP_DATA_PORT | | |
| Comment | | | |
| in | HTTP_DATA_IND | | |
| out | HTTP_DATA_REQ | | |

H.4 References to TTCN-3

| References to TTCN-3 | | |
|--------------------------|-----------------------------|-----------|
| IMS_PTC_CoordMsg | IMS/IMS_PTC_CoordMsg.ttcn | Rev 16131 |
| IMS_ASP_TypeDefs | IMS/IMS_ASP_TypeDefs.ttcn | Rev 13970 |
| HTTP_ASP_TypeDefs | HTTP/HTTP_ASP_TypeDefs.ttcn | Rev 15843 |

Annex I (informative): Change history

| Meeting | TSG doc | CR | Rev | Subject | Cat | Old vers | New vers | WG doc |
|---------|-----------|------|-----|---|-----|----------|----------|-----------|
| RP-31 | RP-060054 | - | - | Update to version 1.0.0 and present to RAN#31 for information | - | - | 1.0.0 | R5-060513 |
| RP-34 | RP-060664 | - | - | Present version 1.3.0 to RAN#34 for information | - | - | 1.3.0 | R5-063500 |
| RP-35 | RP-070010 | - | - | Presented as version 2.0.0 for approval to go under revision control | - | - | 2.0.0 | R5-070456 |
| - | - | - | - | Upgraded to version 5.0.0 by the 3GPP support | - | - | 5.0.0 | - |
| RP-36 | RP-070352 | 0001 | - | Addition of IMS-CC test case 8.6 to IMS_CC ATS V1.3.0 | F | 5.0.0 | 5.1.0 | R5s070101 |
| RP-36 | RP-070353 | 0002 | - | CR to 34.229-3: Add new verified and e-mail agreed TTCN test cases in the TC lists in 34.229-3 (prose), Annex A | F | 5.0.0 | 5.1.0 | - |
| RP-37 | RP-070594 | 0003 | - | Extension to TTCN ASP DeactivatePDPCContextReq | F | 5.1.0 | 5.2.0 | R5-072509 |
| RP-37 | RP-070594 | 0004 | - | IMS CC / PIXIT parameter px_CellId | F | 5.1.0 | 5.2.0 | R5-072546 |
| RP-38 | RP-070870 | 0007 | | Addition of IMS-CC test case 8.5 to IMS_CC ATS V5.1.0 | B | 5.2.0 | 5.3.0 | R5s070489 |
| RP-38 | RP-070870 | 0008 | | Addition of IMS-CC test case 8.7 to IMS_CC ATS V5.3.0 | B | 5.2.0 | 5.3.0 | R5s070259 |
| RP-38 | RP-070870 | 0009 | | Addition of IMS-CC test case 9.1 to IMS_CC ATS V5.3.0 | B | 5.2.0 | 5.3.0 | R5s070261 |
| RP-38 | RP-070889 | 0010 | | CR to 34.229-3: Add new verified and e-mail agreed TTCN test cases in the TC lists in 34.229-3 (prose), Annex A | F | 5.2.0 | 5.3.0 | - |
| RP-38 | RP-070869 | 0006 | | Production of 34.229-3 pointer version in Rel-5 pointing to Rel-6 version | F | 5.2.0 | 5.3.0 | R5-073439 |
| RP-38 | RP-070869 | 0005 | | Addition of an MMI command | F | 5.2.0 | 6.0.0 | R5-073046 |
| RP-39 | RP-080098 | 0011 | | Update of MMI command strings | F | 6.0.0 | 6.1.0 | R5-080041 |
| RP-39 | RP-080089 | 0012 | | CR to 34.229-3: Add new verified and e-mail agreed TTCN test cases in the TC lists in 34.229-3 (prose), Annex A | F | 6.0.0 | 6.1.0 | - |
| RP-39 | RP-080094 | 0013 | | Addition of IMS-CC test case 7.2 to IMS_CC ATS V5.3.0 | B | 6.0.0 | 6.1.0 | R5s070535 |
| RP-39 | RP-080094 | 0014 | | Addition of IMS-CC test case 10.1 to IMS_CC ATS V5.1.0 | B | 6.0.0 | 6.1.0 | R5s070549 |
| RP-39 | RP-080094 | 0015 | | Addition of IMS-CC test case 8.3 to IMS_CC ATS V5.1.0 | B | 6.0.0 | 6.1.0 | R5s070545 |
| RP-39 | RP-080094 | 0016 | | Addition of IMS-CC test case 8.2 to IMS_CC ATS V5.1.0 | B | 6.0.0 | 6.1.0 | R5s070543 |
| RP-39 | RP-080094 | 0017 | | Addition of IMS-CC test case 7.6 to IMS_CC ATS V5.1.0 | B | 6.0.0 | 6.1.0 | R5s070539 |
| RP-39 | RP-080094 | 0018 | | Addition of IMS-CC test case 7.4 to IMS_CC ATS V5.1.0 | B | 6.0.0 | 6.1.0 | R5s070537 |
| RP-39 | RP-080094 | 0019 | | Addition of IMS-CC test case 11.1 to IMS_CC ATS V5.1.0 | B | 6.0.0 | 6.1.0 | R5s070551 |
| RP-39 | RP-080094 | 0020 | | Addition of IMS-CC test case 14.1 to IMS_CC ATS V5.1.0 | B | 6.0.0 | 6.1.0 | R5s070555 |
| RP-39 | RP-080094 | 0021 | | Addition of IMS-CC test case 13.1 to IMS_CC ATS V5.1.0 | B | 6.0.0 | 6.1.0 | R5s070553 |
| RP-39 | RP-080094 | 0022 | | Addition of IMS-CC test case 8.4 to IMS_CC ATS V5.1.0 | B | 6.0.0 | 6.1.0 | R5s070547 |
| RP-39 | RP-080094 | 0023 | | Addition of IMS-CC test case 8.1 to IMS_CC ATS V5.1.0 | B | 6.0.0 | 6.1.0 | R5s070541 |
| RP-39 | RP-080094 | 0024 | | Addition of IMS-CC test case 7.1 to IMS_CC ATS V5.1.0 | B | 6.0.0 | 6.1.0 | R5s070491 |
| RP-39 | RP-080094 | 0025 | | Common corrections to IMS-CC test cases | F | 6.0.0 | 6.1.0 | R5s070534 |
| RP-40 | RP-080369 | 0027 | | Correction to regular expressions in IMS | F | 6.1.0 | 7.0.0 | R5s080036 |
| RP-40 | RP-080369 | 0028 | | IMS ATS / handling of P-Access-Network-Info header over non secure ports | F | 6.1.0 | 7.0.0 | R5s080063 |
| RP-40 | RP-080369 | 0029 | | IMS ATS / test case 9.1 / handling of authorization header in Register messages | F | 6.1.0 | 7.0.0 | R5s080085 |
| RP-40 | RP-080376 | 0030 | | Extend test model supporting XCAP test | F | 6.1.0 | 7.0.0 | R5-081036 |
| RP-41 | RP-080654 | 0031 | | CR to 34.229-3: Add new verified and e-mail agreed TTCN test cases in the TC lists in 34.229-3 (prose), Annex A | F | 7.0.0 | 7.1.0 | - |
| RP-41 | RP-080615 | 0032 | | Addition of IMS-CC test case 9.2 to IMS_CC ATS v.7.0.0 | F | 7.0.0 | 7.1.0 | R5s080115 |
| RP-41 | RP-080615 | 0033 | | Addition of IMS-CC test case 7.3 to IMS_CC ATS v.7.0.0 | F | 7.0.0 | 7.1.0 | R5s080114 |

| Meeting | TSG doc | CR | Rev | Subject | Cat | Old vers | New vers | WG doc |
|---------|-----------|------|-----|---|-----|----------|----------|-----------|
| RP-41 | RP-080615 | 0034 | | Implementation of IPCanCtl code as a parallel test component | F | 7.0.0 | 7.1.0 | R5s080138 |
| RP-41 | RP-080615 | 0035 | | Addition of IMS-CC test case 8.9 to IMS_CC ATS v.6.2.0 | F | 7.0.0 | 7.1.0 | R5s080145 |
| RP-41 | RP-080615 | 0036 | | Addition of IMS-CC test case 8.8 to IMS_CC ATS v.6.2.0 | F | 7.0.0 | 7.1.0 | R5s080143 |
| RP-41 | RP-080615 | 0037 | | Addition of IMS-CC test case 7.5 to IMS_CC ATS | F | 7.0.0 | 7.1.0 | R5s080151 |
| RP-41 | RP-080740 | 0038 | | Update of TS 34.229-3 from Rel-6 to Rel-7 | F | 7.1.0 | 7.2.0 | R5-083065 |
| RP-42 | RP-080959 | 0039 | | Correction of HW Type and HW Length fields in DHCP response messages | F | 7.1.0 | 7.2.0 | R5s080171 |
| RP-42 | RP-080959 | 0040 | | Minor correction of Route header template in the initial Register message | F | 7.1.0 | 7.2.0 | R5s080168 |
| RP-43 | RP-090210 | 0041 | | Update of TS 34.229-3 from Rel-7 to Rel-8 | F | 7.2.0 | 8.0.0 | R5-090765 |
| RP-43 | RP-090210 | 0042 | | IMS CC ATS / Improvement: Stopping test case execution once a PTC fails | F | 8.0.0 | 8.1.0 | R5s090019 |
| RP-43 | RP-090210 | 0043 | | IMS CC ATS / Handling of non-default port number in the Contact Header | F | 8.0.0 | 8.1.0 | R5s090018 |
| RP-43 | RP-090210 | 0044 | | IMS CC ATS / Handling of Contact Header | F | 8.0.0 | 8.1.0 | R5s090005 |
| RP-43 | RP-090210 | 0045 | | IMS CC / Minor corrections on test 11.2 (re-authentication) | F | 8.0.0 | 8.1.0 | R5s090004 |
| RP-43 | RP-090210 | 0046 | | IMS CC / Addition of test case 11.2 to the IMS ATS | F | 8.0.0 | 8.1.0 | R5s080313 |
| RP-43 | RP-090210 | 0047 | | IMS CC test model / Addition of new ASP to reconfigure IP Layer | F | 8.0.0 | 8.1.0 | R5-090032 |
| RP-43 | RP-090210 | 0048 | | Removal of an unused pixit and other routine updates | F | 8.0.0 | 8.1.0 | R5-090056 |
| RP-46 | RP-091156 | 0049 | - | CR to 34.229-3 (prose) update to v820 | F | 8.1.0 | 8.2.0 | - |
| RP-47 | RP-100146 | 0050 | - | CR to 34.229-3 (prose) update to v830 | F | 8.2.0 | 8.3.0 | - |
| RP-47 | RP-100155 | 0051 | - | Correction of IMS test model for XCAP-based SS test | F | 8.2.0 | 8.3.0 | R5-100087 |
| RP-47 | RP-100140 | 0052 | - | Add bearer information for E-UTRA | F | 8.2.0 | 8.3.0 | R5-100414 |
| RP-48 | RP-100514 | 0053 | - | CR to 34.229-3 (prose) update to v840 | F | 8.3.0 | 8.4.0 | - |
| RP-48 | RP-100511 | 0054 | - | Update IMS test model | F | 8.3.0 | 8.4.0 | R5-103382 |
| RP-50 | RP-101146 | 0055 | - | Routine maintenance of TS 34.229-3 | F | 8.4.0 | 8.5.0 | R5-106088 |
| RP-50 | RP-101150 | 0056 | - | CR to 34.229-3 update to v850 | F | 8.4.0 | 8.5.0 | - |
| RP-51 | RP-110165 | 0057 | - | Mapping of some PIXIT parameters to ISIM Efs – 3 IMPU | F | 8.5.0 | 8.6.0 | R5-110694 |
| RP-51 | RP-110169 | 0058 | - | CR to 34.229-3 (prose) update to v860 | F | 8.5.0 | 8.6.0 | - |
| RP-52 | RP-110651 | 0059 | - | Removal of technical content in 34.229-3 v8.6.0 and substitution with pointer to the next Release | F | 8.6.0 | 8.7.0 | R5-112246 |
| RP-52 | RP-110651 | 0060 | - | Routine maintenance | F | 8.6.0 | 9.0.0 | R5-112648 |
| RP-52 | RP-110655 | 0061 | - | CR to 34.229-3 (prose) update to v870 | F | 8.6.0 | 9.0.0 | - |
| RP-53 | RP-111160 | 0062 | - | CR to 34.229-3 (prose) update to v910 | F | 9.0.0 | 9.1.0 | - |
| RP-54 | RP-111584 | 0063 | - | Routine maintenance and updates for IMS ASP | F | 9.1.0 | 9.2.0 | R5-115670 |
| RP-55 | RP-120187 | 0064 | - | CR to 34.229-3 (prose) update to v930 | F | 9.2.0 | 9.3.0 | - |
| RP-56 | RP-120649 | 0065 | - | Routine maintenance and updates | F | 9.3.0 | 9.4.0 | R5-121090 |
| RP-56 | RP-120802 | 0066 | - | Correction to IMS CC test cases / IPv6 address handling | F | 9.3.0 | 9.4.0 | R5s120108 |
| RP-57 | RP-121103 | 0067 | - | 34229-3: Routine maintenance and updates | F | 9.4.0 | 9.5.0 | R5-123085 |
| RP-57 | RP-121221 | 0068 | - | TTCN IMS correction | F | 9.4.0 | 9.5.0 | R5s120530 |
| RP-57 | RP-121221 | 0069 | - | Addition of GCF WI-031 IMS test case 8.10 | F | 9.4.0 | 9.5.0 | R5s120537 |
| RP-57 | RP-121221 | 0070 | - | Addition of GCF WI-031 IMS test case 8.12 | F | 9.4.0 | 9.5.0 | R5s120539 |
| RP-57 | RP-121221 | 0071 | - | Addition of GCF WI-031 IMS test case 8.13 | F | 9.4.0 | 9.5.0 | R5s120541 |
| RP-57 | RP-121221 | 0072 | - | Addition of GCF WI-128 IMS test case 18.1 | F | 9.4.0 | 9.5.0 | R5s120543 |
| RP-57 | RP-121221 | 0073 | - | Addition of GCF WI-128 IMS test case 18.2 | F | 9.4.0 | 9.5.0 | R5s120545 |
| RP-57 | RP-121221 | 0074 | - | Addition of GCF WI-103 IMS test case 16.1 | F | 9.4.0 | 9.5.0 | R5s120547 |
| RP-57 | RP-121221 | 0075 | - | Addition of GCF WI-103 IMS test case 16.2 | F | 9.4.0 | 9.5.0 | R5s120549 |
| RP-57 | RP-121106 | 0076 | - | CR to 34.229-3: Add new verified and e-mail agreed TTCN test cases in the TC lists in 34.229-3 (prose), Annex A | F | 9.4.0 | 9.5.0 | - |
| RP-58 | RP-121664 | 0077 | - | 34229-3: Routine maintenance and updates | F | 9.5.0 | 9.6.0 | R5-125120 |
| RP-58 | RP-121669 | 0078 | - | Addition of GCF WI-103 IMS test case 12.12 | B | 9.5.0 | 9.6.0 | R5s120605 |
| RP-58 | RP-121669 | 0079 | - | Addition of GCF WI-103 IMS test case 12.13 | B | 9.5.0 | 9.6.0 | R5s120607 |
| RP-58 | RP-121669 | 0080 | - | Addition of GCF WI-103 IMS test case 15.11 | B | 9.5.0 | 9.6.0 | R5s120609 |
| RP-58 | RP-121669 | 0081 | - | IMS TTCN correction | F | 9.5.0 | 9.6.0 | R5s120729 |
| RP-58 | RP-121669 | 0082 | - | Addition of GCF WI-103 IMS test case 15.8 | B | 9.5.0 | 9.6.0 | R5s120730 |
| RP-58 | RP-121669 | 0083 | - | Addition of GCF WI-103 IMS test case 15.12 | B | 9.5.0 | 9.6.0 | R5s120732 |
| RP-58 | RP-121669 | 0084 | - | Addition of GCF WI-103 IMS test case 15.27 | B | 9.5.0 | 9.6.0 | R5s120733 |
| RP-58 | RP-121669 | 0085 | - | Addition of GCF WI-103 IMS test case 15.28 | B | 9.5.0 | 9.6.0 | R5s120736 |
| RP-58 | RP-121668 | 0086 | - | CR to 34.229-3: Add new verified and e-mail agreed TTCN test cases in the TC lists in 34.229-3 (prose), Annex A | F | 9.5.0 | 9.6.0 | - |
| RP-59 | RP-130145 | 0087 | - | 34229-3: Routine maintenance and updates | F | 9.6.0 | 9.7.0 | R5-130198 |
| RP-59 | RP-130150 | 0088 | - | Re-verification of IMS Registration test case 8.10 over LTE with 36.523-3 test model | F | 9.6.0 | 9.7.0 | R5s120858 |

| Meet-ing | TSG doc | CR | Rev | Subject | Cat | Old vers | New vers | WG doc |
|----------|-----------|------|-----|--|-----|----------|----------|-----------|
| RP-59 | RP-130150 | 0089 | - | Corrections for IMS test cases with 34.229-3 test model | F | 9.6.0 | 9.7.0 | R5s120907 |
| RP-59 | RP-130150 | 0090 | - | Re-verification of IMS Registration test case 8.4 over LTE with new 34.229-3 test model | F | 9.6.0 | 9.7.0 | R5s120945 |
| RP-59 | RP-130150 | 0091 | - | Re-verification of IMS Authentication test case 9.1 over LTE with the new 34.229-3 test model | F | 9.6.0 | 9.7.0 | R5s120947 |
| RP-59 | RP-130150 | 0092 | - | Corrections to IMS_36523_IWD_12wk48 test suite | F | 9.6.0 | 9.7.0 | R5s130011 |
| RP-59 | RP-130150 | 0093 | - | Corrections for IMS TC 8.1 regarding Ipv6 privacy | F | 9.6.0 | 9.7.0 | R5s130049 |
| RP-59 | RP-130149 | 0094 | - | CR to 34.229-3 (prose) update to v970 | F | 9.6.0 | 9.7.0 | - |
| RP-60 | RP-130611 | 0095 | - | 34229-3: Routine maintenance and updates | F | 9.7.0 | 9.8.0 | R5-131140 |
| RP-60 | RP-130617 | 0096 | - | Corrections to feature parameter in MT call invitation | F | 9.7.0 | 9.8.0 | R5s130109 |
| RP-60 | RP-130617 | 0097 | - | Re-verification of IMS Registration (IPSec) test case 8.1 over LTE with 36.523-3 test model | F | 9.7.0 | 9.8.0 | R5s130133 |
| RP-60 | RP-130617 | 0098 | - | Re-verification of IMS test case 8.3 over LTE with 36.523-3 test model | F | 9.7.0 | 9.8.0 | R5s130181 |
| RP-60 | RP-130617 | 0099 | - | Re-verification of IMS SMS test case 18.2 over LTE with 36.523-3 test model | F | 9.7.0 | 9.8.0 | R5s130183 |
| RP-60 | RP-130617 | 0100 | - | Corrections for IMS TC 8.1 | F | 9.7.0 | 9.8.0 | R5s130187 |
| RP-60 | RP-130617 | 0101 | - | Re-verification of IMS Registration test case 8.2 over LTE with 34.229-3 test model | F | 9.7.0 | 9.8.0 | R5s130233 |
| RP-60 | RP-130617 | 0102 | - | Re-verification of IMS SMS test case 18.1 over LTE with 34.229-3 test model | F | 9.7.0 | 9.8.0 | R5s130235 |
| RP-60 | RP-130617 | 0103 | - | Correction to SIP template cr_FromWithTag | F | 9.7.0 | 9.8.0 | R5s130256 |
| RP-60 | RP-130617 | 0104 | - | Re-verification of IMS Authentication test case 9.2 over LTE with 34.229-3 test model | F | 9.7.0 | 9.8.0 | R5s130264 |
| RP-60 | RP-130617 | 0105 | - | Re-verification of IMS Notification test case 11.2 over LTE with 34.229-3 test model | F | 9.7.0 | 9.8.0 | R5s130266 |
| RP-60 | RP-130617 | 0106 | - | Corrections for IMS Registration TC 8.3 over LTE with 34.229-3 test model | F | 9.7.0 | 9.8.0 | R5s130274 |
| RP-60 | RP-130617 | 0107 | - | Re-verification of IMS Subscription test case 10.1 over LTE with 34.229-3 test model | F | 9.7.0 | 9.8.0 | R5s130294 |
| RP-60 | RP-130617 | 0108 | - | Re-verification of IMS Registration test case 11.1 over LTE with 34.229-3 test model | F | 9.7.0 | 9.8.0 | R5s130296 |
| RP-60 | RP-130617 | 0109 | - | Re-verification of IMS Call Control test case 12.12 over LTE with 36.523-3 test model | F | 9.7.0 | 9.8.0 | R5s130333 |
| RP-61 | RP-131107 | 0111 | - | Correction to EPS ATTACH procedure to enable IMS Registration via NAS signalling | F | 9.8.0 | 9.9.0 | R5s130383 |
| RP-61 | RP-131107 | 0112 | - | Correction to IMS test cases 8.1, 8.2, 8.3 and 8.4 | F | 9.8.0 | 9.9.0 | R5s130454 |
| RP-61 | RP-131107 | 0113 | - | Correction to encoding rules to be used for Reginfo_Type | F | 9.8.0 | 9.9.0 | R5s130474 |
| RP-61 | RP-131107 | 0114 | - | Corrections for IMS call control test case 12.12 | F | 9.8.0 | 9.9.0 | R5s130497 |
| RP-61 | RP-131107 | 0115 | - | Addition of GCF WI-154/ee1 IMS Emergency Call over EPS test case 19.1.2 (using TS 36.523-3 test model) | B | 9.8.0 | 9.9.0 | R5s130508 |
| RP-61 | RP-131107 | 0116 | - | Re-verification for IMS TC 12.13 over LTE with 34.229-3 test model | F | 9.8.0 | 9.9.0 | R5s130510 |
| RP-61 | RP-131107 | 0117 | - | Corrections to GCF WI-128 SMS over IMS Testcase 18.1 | F | 9.8.0 | 9.9.0 | R5s130514 |
| RP-61 | RP-131107 | 0118 | - | Correction of IMS test case 9.2 over LTE with 34.229-3 test model | F | 9.8.0 | 9.9.0 | R5s130573 |

| Meeting | TSG doc | CR | Rev | Subject | Cat | Old vers | New vers | WG doc |
|---------|-----------|------|-----|---|-----|----------|----------|-----------|
| RP-61 | RP-131107 | 0119 | - | Verification for IMS test case 12.2 over LTE with 34.229-1 test model | B | 9.8.0 | 9.9.0 | R5s130580 |
| RP-61 | RP-131107 | 0120 | - | Correction of IMS test case 12.12 over LTE with 34.229-3 test model | F | 9.8.0 | 9.9.0 | R5s130586 |
| RP-61 | RP-131106 | 0121 | - | CR to 34.229-3: Add new verified and e-mail agreed TTCN test cases in the TC lists in 34.229-3 (prose), Annex A | F | 9.8.0 | 9.9.0 | RP-131106 |
| RP-61 | RP-131100 | 0110 | - | 34229-3: Routine maintenance and updates | F | 9.9.0 | 10.0.0 | R5-133632 |
| RP-62 | RP-131875 | 0122 | - | Splitting 34.229-3 | F | 10.0.0 | 10.1.0 | R5-134070 |
| RP-62 | RP-132006 | 0123 | - | 34229-3: Routine maintenance and updates for multi-testers model | F | 10.0.0 | 10.1.0 | R5-134290 |
| RP-62 | RP-131868 | 0125 | - | Regression CR for IMS registration procedure in ATS_13wk35 | F | 10.0.0 | 10.1.0 | R5s130681 |
| RP-62 | RP-131868 | 0126 | - | Correction of IMS test case 12.2 over LTE with 34.229-3 test model | F | 10.0.0 | 10.1.0 | R5s130684 |
| RP-62 | RP-131868 | 0127 | - | Correction of IMS test case 12.13 over LTE with 34.229-3 test model | F | 10.0.0 | 10.1.0 | R5s130685 |
| RP-62 | RP-131868 | 0128 | - | Correction of IMS test case 8.1 over LTE with 34.229-3 test model | F | 10.0.0 | 10.1.0 | R5s130710 |
| RP-62 | RP-131868 | 0129 | - | Correction to usage of constant tsc_IMS_AcceptContactValue | F | 10.0.0 | 10.1.0 | R5s130738 |
| RP-62 | RP-131868 | 0130 | - | Correction to SMS over IMS test case 18.2 | F | 10.0.0 | 10.1.0 | R5s130739 |
| RP-62 | RP-131868 | 0131 | - | Corrections to IMS codec selection test case 16.1 and 16.2 | F | 10.0.0 | 10.1.0 | R5s130742 |
| RP-62 | RP-131868 | 0132 | - | Correction to IMS Call Control test case 12.13 | F | 10.0.0 | 10.1.0 | R5s130743 |
| RP-62 | RP-131868 | 0133 | - | Correction to GCF WI-154 IMS Emergency Call over EPS test case 19.1.2 | F | 10.0.0 | 10.1.0 | R5s130760 |
| RP-62 | RP-131868 | 0134 | - | Corrections to number of channels in SDP in 34.229-3 test model | F | 10.0.0 | 10.1.0 | R5s130798 |
| RP-62 | RP-131867 | 0135 | - | CR to 34.229-3 (prose) update to v10.1.0 | F | 10.0.0 | 10.1.0 | RP-131867 |
| RP-63 | R5-140319 | 0136 | - | Routine maintenance and updates | F | 10.1.0 | 10.2.0 | R5-140931 |
| RP-63 | RP-140313 | 0137 | - | Addition of GCF WI-171 MTSI MO speech call / SSAC test case 12.18 (using TS 36.523-3 test model) | B | 10.1.0 | 10.2.0 | R5s130766 |
| RP-63 | RP-140313 | 0138 | - | Addition of GCF WI-171 IMS Emergency call / SSAC test case 12.20 (using TS 36.523-3 test model) | B | 10.1.0 | 10.2.0 | R5s130768 |
| RP-63 | RP-140313 | 0139 | - | Re-verification of MTSI MT speech call test case 12.13 (... using TS 36.523-3 test model) | F | 10.1.0 | 10.2.0 | R5s130770 |
| RP-63 | RP-140313 | 0140 | - | Re-verification of IMS test case 16.1 over LTE with 34.229-3 test model | F | 10.1.0 | 10.2.0 | R5s130808 |
| RP-63 | RP-140313 | 0141 | - | Re-verification of IMS test case 16.2 over LTE with 34.229-3 test model | F | 10.1.0 | 10.2.0 | R5s130810 |
| RP-63 | RP-140313 | 0142 | - | Correction of IMS test case 12.2 over LTE with 34.229-3 test model | F | 10.1.0 | 10.2.0 | R5s130885 |
| RP-63 | RP-140313 | 0143 | - | Correction of IMS test case 12.12 over LTE with 34.229-3 test model | F | 10.1.0 | 10.2.0 | R5s130894 |
| RP-63 | RP-140313 | 0144 | - | Corrections for common IMS functions | F | 10.1.0 | 10.2.0 | R5s130897 |

| Meeting | TSG doc | CR | Rev | Subject | Cat | Old vers | New vers | WG doc |
|---------|-----------|------|-----|---|-----|----------|----------|-----------|
| RP-63 | RP-140313 | 0145 | - | Correction to GCF WI-103 IMS test case 11.2 with 36.523-3 Test Model | F | 10.1.0 | 10.2.0 | R5s130900 |
| RP-63 | RP-140313 | 0146 | - | Correction to Postamble handling for IMS deregistration procedure | F | 10.1.0 | 10.2.0 | R5s130901 |
| RP-63 | RP-140313 | 0147 | - | Correction to fl_EUTRA_IPCAN_ActivateDedicatedEpsBearer_SpeechCall | F | 10.1.0 | 10.2.0 | R5s130916 |
| RP-63 | RP-140313 | 0148 | - | Correction of IMS test case 8.10 over LTE with 34.229-3 test model | F | 10.1.0 | 10.2.0 | R5s130925 |
| RP-63 | RP-140313 | 0149 | - | Addition of GCF WI-103 IMS MTSI test case 16.3 over 36.523-3 Test Model | B | 10.1.0 | 10.2.0 | R5s130956 |
| RP-63 | RP-140313 | 0150 | - | Addition of GCF WI-103 IMS MTSI test case 16.4 over 36.523-3 Test Model | B | 10.1.0 | 10.2.0 | R5s130958 |
| RP-63 | RP-140313 | 0151 | - | Correction to GCF WI-154 IMS Emergency Call over EPS test case 19.1.2 | F | 10.1.0 | 10.2.0 | R5s130978 |
| RP-63 | RP-140313 | 0152 | - | Correction to GCF WI-103 IMS MTSI test case 12.13 | F | 10.1.0 | 10.2.0 | R5s130985 |
| RP-63 | RP-140313 | 0153 | - | Addition of GCF WI-154 IMS Emergency Call over EPS test case 19.4.1 | B | 10.1.0 | 10.2.0 | R5s130990 |
| RP-63 | RP-140313 | 0154 | - | Correction to GCF WI-103 IMS MTSI test case 9.2 | F | 10.1.0 | 10.2.0 | R5s131004 |
| RP-63 | RP-140313 | 0155 | - | Correction to GCF WI-103 IMS MTSI test case 11.2 | F | 10.1.0 | 10.2.0 | R5s131040 |
| RP-63 | RP-140313 | 0156 | - | Correction of common altsteps in IMS PTC for test case 11.2 | F | 10.1.0 | 10.2.0 | R5s140003 |
| RP-63 | RP-140313 | 0157 | - | Correction for IMS common function f_IMS_InviteRequest_MessageHeaderRX() | F | 10.1.0 | 10.2.0 | R5s140005 |
| RP-63 | RP-140313 | 0158 | - | Re-verification of IMS test case 15.11 over LTE with 34.229-3 test model | F | 10.1.0 | 10.2.0 | R5s140017 |
| RP-63 | RP-140312 | 0159 | - | CR to 34.229-3: Add new verified and e-mail agreed TTCN test cases in the TC lists in 34.229-3 (prose), Annex A | F | 10.1.0 | 10.2.0 | RP-140312 |
| RP-64 | RP-140812 | 0160 | - | Routine maintenance and updates | F | 10.2.0 | 10.3.0 | R5-142961 |
| RP-64 | RP-140822 | 0161 | - | Addition of GCF WI-154 IMS Emergency Call over EPS test case 19.5.6 (with TS 36.523-3 test model) | F | 10.2.0 | 10.3.0 | R5s140037 |
| RP-64 | RP-140822 | 0162 | - | Addition of GCF WI-154 IMS Emergency Call over EPS test case 19.5.10 (with TS 36.523-3 test model) | F | 10.2.0 | 10.3.0 | R5s140039 |
| RP-64 | RP-140822 | 0163 | - | Addition of GCF WI-103 IMS MTSI Testcase 15.28 with 36.523-3 Test Model | F | 10.2.0 | 10.3.0 | R5s140092 |
| RP-64 | RP-140822 | 0164 | - | Re-verification of GCF WI-103 IMS MTSI Testcase 15.11 over 36.523-3 Test Model | F | 10.2.0 | 10.3.0 | R5s140121 |
| RP-64 | RP-140822 | 0165 | - | Addition of GCF WI-154 IMS Emergency Testcase 19.4.5 with 36.523-3 Test Model | F | 10.2.0 | 10.3.0 | R5s140123 |
| RP-64 | RP-140822 | 0166 | - | Correction of GCF WI-103 IMS MTSI Testcase 9.1 | F | 10.2.0 | 10.3.0 | R5s140136 |
| RP-64 | RP-140822 | 0167 | - | Correction to GCF WI-171 IMS SSAC testcase 12.20 | F | 10.2.0 | 10.3.0 | R5s140137 |
| RP-64 | RP-140822 | 0168 | - | Correction of P-Preferred-Service and P-Asserted-Service usage over LTE with 34.229-3 test model | F | 10.2.0 | 10.3.0 | R5s140141 |
| RP-64 | RP-140822 | 0169 | - | Addition of GCF WI-103 IMS MO Call test case 12.2a (... with both TS 36.523-3 and TS 34.229-3 test model) | F | 10.2.0 | 10.3.0 | R5s140142 |
| RP-64 | RP-140822 | 0170 | - | Correction to GCF WI-171 SSAC testcase 12.20 | F | 10.2.0 | 10.3.0 | R5s140168 |

| Meeting | TSG doc | CR | Rev | Subject | Cat | Old vers | New vers | WG doc |
|---------|-----------|------|-----|---|-----|----------|----------|-----------|
| RP-64 | RP-140822 | 0171 | - | Correction to GCF WI-154 IMS Emergency Call testcase 19.1.2 | F | 10.2.0 | 10.3.0 | R5s140171 |
| RP-64 | RP-140822 | 0172 | - | Correction to GCF WI-154 IMS Emergency Call testcase 19.5.6 | F | 10.2.0 | 10.3.0 | R5s140172 |
| RP-64 | RP-140822 | 0173 | - | Correction to IMS function f_IMS_Dialog_SetRemoteTag | F | 10.2.0 | 10.3.0 | R5s140173 |
| RP-64 | RP-140822 | 0174 | - | Correction of IMS function f_IMS_PTC_ImInfo_DialogInit | F | 10.2.0 | 10.3.0 | R5s140174 |
| RP-64 | RP-140822 | 0175 | - | Correction to Postamble Procedure for IMS Testcases | F | 10.2.0 | 10.3.0 | R5s140175 |
| RP-64 | RP-140822 | 0176 | - | Correction to GCF WI-103 IMS MTSI Testcases 9.1 and 9.2 | F | 10.2.0 | 10.3.0 | R5s140176 |
| RP-64 | RP-140822 | 0177 | - | Correction of GCF WI-103 IMS MTSI Testcase 15.28 | F | 10.2.0 | 10.3.0 | R5s140178 |
| RP-64 | RP-140822 | 0178 | - | Correction to IMS Route header in ACK sent by SS | F | 10.2.0 | 10.3.0 | R5s140194 |
| RP-64 | RP-140822 | 0179 | - | Correction to 183 Session Progress Message | F | 10.2.0 | 10.3.0 | R5s140204 |
| RP-64 | RP-140822 | 0180 | - | Correction to TCP Connection Close procedure for IMS Testcases | F | 10.2.0 | 10.3.0 | R5s140219 |
| RP-64 | RP-140822 | 0181 | - | Correction to IMS Main PTC Function | F | 10.2.0 | 10.3.0 | R5s140243 |
| RP-64 | RP-140822 | 0182 | - | Correction of f_IMS_AckRequest_MessageHeaderRX() | F | 10.2.0 | 10.3.0 | R5s140264 |
| RP-64 | RP-140822 | 0183 | - | Correction of f_IPCAN_StartProcedure | F | 10.2.0 | 10.3.0 | R5s140265 |
| RP-64 | RP-140822 | 0184 | - | spi and port values | F | 10.2.0 | 10.3.0 | R5s140266 |
| RP-64 | RP-140822 | 0185 | - | Correction to GCF WI-103 IMS Call Control Test Case 11.2 | F | 10.2.0 | 10.3.0 | R5s140303 |
| RP-64 | RP-140822 | 0186 | - | Correction to SMS over IMS Test Case 18.1 | F | 10.2.0 | 10.3.0 | R5s140304 |
| RP-64 | RP-140822 | 0187 | - | Re-verification of IMS test case 15.27 over LTE with 34.229-3 test model | F | 10.2.0 | 10.3.0 | R5s140307 |
| RP-64 | RP-140822 | 0188 | - | Re-verification of IMS test case 15.12 over LTE with 34.229-3 test model | F | 10.2.0 | 10.3.0 | R5s140324 |
| RP-64 | RP-140822 | 0189 | - | Addition of GCF WI-154 IMS Emergency Call over EPS test case 19.5.9 with 36.523-3 test model | F | 10.2.0 | 10.3.0 | R5s140329 |
| RP-64 | RP-140822 | 0190 | - | Correction to GCF WI-171 IMS SSAC Testcase 12.18 | F | 10.2.0 | 10.3.0 | R5s140334 |
| RP-64 | RP-140822 | 0191 | - | Correction to WI-103 IMS MTSI Testcase 11.1 | F | 10.2.0 | 10.3.0 | R5s140342 |
| RP-64 | RP-140822 | 0192 | - | Correction for checking of via Header in IMS response messages | F | 10.2.0 | 10.3.0 | R5s140350 |
| RP-64 | RP-140822 | 0193 | - | Verification of IMS test case 8.11 over LTE with 34.229-3 test model | F | 10.2.0 | 10.3.0 | R5s140356 |
| RP-64 | RP-140822 | 0194 | - | Corrections for IMS MO call setup sequence with preconditions | F | 10.2.0 | 10.3.0 | R5s140359 |
| RP-64 | RP-140822 | 0195 | - | Corrections to de-registration procedure | F | 10.2.0 | 10.3.0 | R5s140428 |
| RP-64 | RP-140821 | 0196 | - | CR to 34.229-3: Add new verified and e-mail agreed TTCN test cases in the TC lists in 34.229-3 (prose), Annex A | F | 10.2.0 | 10.3.0 | RP-140821 |
| RP-65 | RP-141571 | 0197 | - | Routine maintenance and updates | F | 10.3.0 | 10.4.0 | R5-144747 |

| Meeting | TSG doc | CR | Rev | Subject | Cat | Old vers | New vers | WG doc |
|---------|-----------|------|-----|---|-----|----------|----------|-----------|
| RP-65 | RP-141580 | 0217 | - | CR to 34.229-3: Add new verified and e-mail agreed TTCN test cases in the TC lists in 34.229-3 (prose), Annex A | F | 10.3.0 | 10.4.0 | - |
| RP-65 | RP-141581 | 0198 | - | Addition of GCF WI-154 IMS Emergency Call test case 19.5.7 with TS 36.523-3 test model | B | 10.3.0 | 10.4.0 | R5s140338 |
| RP-65 | RP-141581 | 0199 | - | Correction for IMS Codec Selection test cases 16.3 and 16.4 | F | 10.3.0 | 10.4.0 | R5s140360 |
| RP-65 | RP-141581 | 0200 | - | IMS test case 18.1 for GIBA | F | 10.3.0 | 10.4.0 | R5s140469 |
| RP-65 | RP-141581 | 0201 | - | Addition of GCF WI-154 IMS Emergency Call test case 19.3.3 with TS 36.523-3 test model | B | 10.3.0 | 10.4.0 | R5s140490 |
| RP-65 | RP-141581 | 0202 | - | Correction to IMS function f_IMS_MTCallSetup_SendPRACK_ReceiveOK. | F | 10.3.0 | 10.4.0 | R5s140551 |
| RP-65 | RP-141581 | 0203 | - | Correction to GCF WI-103 IMS MTSI test case 11.2. | F | 10.3.0 | 10.4.0 | R5s140561 |
| RP-65 | RP-141581 | 0204 | - | Regression CR for IMS modules in ATS_14wk24 | F | 10.3.0 | 10.4.0 | R5s140565 |
| RP-65 | RP-141581 | 0205 | - | Corrections for IMS Codec Selection test cases 16.3 and 16.4 | F | 10.3.0 | 10.4.0 | R5s140567 |
| RP-65 | RP-141581 | 0206 | - | Correction to GCF WI-103 IMS test case 15.12 | F | 10.3.0 | 10.4.0 | R5s140571 |
| RP-65 | RP-141581 | 0207 | - | Correction of IMS SSAC Testcases 12.18, 12.19, 12.20, 12.18a, 12.19a and 12.20a | F | 10.3.0 | 10.4.0 | R5s140577 |
| RP-65 | RP-141581 | 0208 | - | Re-verification of GCF WI-103 IMS Codec Selecting test case 16.2 with 36.523-3 test model | F | 10.3.0 | 10.4.0 | R5s140580 |
| RP-65 | RP-141581 | 0209 | - | Corrections to IMS test case 15.11 | F | 10.3.0 | 10.4.0 | R5s140602 |
| RP-65 | RP-141581 | 0210 | - | Correction to IMS test case 15.27 | F | 10.3.0 | 10.4.0 | R5s140606 |
| RP-65 | RP-141581 | 0211 | - | Re-verification of IMS test case 15.8 over LTE with 34.229-3 test model | F | 10.3.0 | 10.4.0 | R5s140621 |
| RP-65 | RP-141581 | 0212 | - | Correction to IMS test case 16.2 | F | 10.3.0 | 10.4.0 | R5s140646 |
| RP-65 | RP-141581 | 0213 | - | Correction to GCF WI-154 IMS Emergency Call Testcase 19.5.7 | F | 10.3.0 | 10.4.0 | R5s140647 |
| RP-65 | RP-141581 | 0214 | - | Correction to ContactIE and UL Grant to IMS messages | F | 10.3.0 | 10.4.0 | R5s140676 |
| RP-65 | RP-141581 | 0215 | - | Bandwidth values for TCs 16.2, 16.3, and 16.4 | F | 10.3.0 | 10.4.0 | R5s140678 |
| RP-65 | RP-141581 | 0216 | - | Correction to Socket Handling during IMS registration procedure | F | 10.3.0 | 10.4.0 | R5s140713 |
| RP-66 | RP-142054 | 0218 | - | Routine maintenance and updates | F | 10.4.0 | 10.5.0 | R5-145191 |
| RP-66 | RP-142064 | 0219 | - | Correction of IMS test case 8.2 over LTE | F | 10.4.0 | 10.5.0 | R5s140779 |
| RP-66 | RP-142064 | 0220 | - | Correction of IMS test case 12.2a | F | 10.4.0 | 10.5.0 | R5s140780 |
| RP-66 | RP-142064 | 0221 | - | Correction to IMS Emergency Call test case 19.4.5 | F | 10.4.0 | 10.5.0 | R5s140786 |
| RP-66 | RP-142064 | 0222 | - | Addition of GCF WI-154 IMS emergency call testcase 19.1.3 over 36.523-3 Test Model | F | 10.4.0 | 10.5.0 | R5s140788 |
| RP-66 | RP-142064 | 0223 | - | Correction to IMS Emergency Call test case 19.5.7 | F | 10.4.0 | 10.5.0 | R5s140791 |
| RP-66 | RP-142064 | 0224 | - | Correction to GCF WI-103 IMS testcase 11.2 | F | 10.4.0 | 10.5.0 | R5s140801 |
| RP-66 | RP-142064 | 0225 | - | Correction to IMS test case 12.2a on branch parameter | F | 10.4.0 | 10.5.0 | R5s140802 |
| RP-66 | RP-142064 | 0226 | - | Correction to GCF WI-103 IMS test case 12.2a | F | 10.4.0 | 10.5.0 | R5s140856 |

| Meeting | TSG doc | CR | Rev | Subject | Cat | Old vers | New vers | WG doc |
|---------|-----------|------|-----|---|-----|----------|----------|-----------|
| RP-66 | RP-142064 | 0227 | - | Correction to GCF WI-103 IMS test case 15.8 | F | 10.4.0 | 10.5.0 | R5s140905 |
| RP-66 | RP-142064 | 0228 | - | Correction to WI-154 IMS Emergency Call Testcases 19.5.6 and 19.5.7 | F | 10.4.0 | 10.5.0 | R5s140909 |
| RP-66 | RP-142064 | 0229 | - | Correction of IMS test case 15.11 | F | 10.4.0 | 10.5.0 | R5s140919 |
| RP-66 | RP-142064 | 0230 | - | Corrections for Ipv6 address checking in common IMS functions | F | 10.4.0 | 10.5.0 | R5s140934 |
| RP-66 | RP-142064 | 0231 | - | Correction of IMS test case 18.1 | F | 10.4.0 | 10.5.0 | R5s140968 |
| RP-66 | RP-142064 | 0232 | - | Verification of IMS test case 15.5 | F | 10.4.0 | 10.5.0 | R5s140975 |
| RP-66 | RP-142064 | 0233 | - | Verification of IMS test case 15.7 | F | 10.4.0 | 10.5.0 | R5s140976 |
| RP-66 | RP-142064 | 0234 | - | Verification of IMS test case 15.9 | F | 10.4.0 | 10.5.0 | R5s140977 |
| RP-66 | RP-142064 | 0235 | - | Correction to IMS Emergency Call test case 19.3.3 | F | 10.4.0 | 10.5.0 | R5s140997 |
| RP-66 | RP-142064 | 0236 | - | Correction to GCF WI-103 IMS MTSI test case 15.11 | F | 10.4.0 | 10.5.0 | R5s141020 |
| RP-66 | RP-142064 | 0237 | - | Addition of GCF WI-103 IMS XCAP Supplementary Service Testcase 15.1 over 36.523-3 Test Model | F | 10.4.0 | 10.5.0 | R5s141051 |
| RP-66 | RP-142064 | 0238 | - | Addition of GCF WI-103 XCAP supplementary service Testcase 15.3 over 36.523-3 Test Model | F | 10.4.0 | 10.5.0 | R5s141053 |
| RP-66 | RP-142064 | 0239 | - | Addition of GCF WI-103 XCAP supplementary service Testcase 15.4 over 36.523-3 Test Model | F | 10.4.0 | 10.5.0 | R5s141055 |
| RP-66 | RP-142064 | 0240 | - | Addition of XCAP supplementary service Testcase 15.14 over 36.523-3 Test Model | F | 10.4.0 | 10.5.0 | R5s141113 |
| RP-66 | RP-142064 | 0241 | - | Addition of GCF WI-103 XCAP supplementary service Testcase 15.14a over 36.523-3 Test Model | F | 10.4.0 | 10.5.0 | R5s141115 |
| RP-66 | RP-142064 | 0242 | - | Addition of IMS over UTRAN testcase 6.3 to IMS Utran testsuite | F | 10.4.0 | 10.5.0 | R5s141125 |
| RP-66 | RP-142064 | 0243 | - | Re-Verification of IMS over UTRAN testcase 7.1 to IMS Utran testsuite | F | 10.4.0 | 10.5.0 | R5s141127 |
| RP-66 | RP-142064 | 0244 | - | Re-verification of GCF WI-103 IMS XCAP Supplementary Service Testcase 15.5 over 36.523-3 Test Model | F | 10.4.0 | 10.5.0 | R5s141130 |
| RP-66 | RP-142064 | 0245 | - | Re-verification of GCF WI-103 IMS XCAP Supplementary Service Testcase 15.7 over 36.523-3 Test Model | F | 10.4.0 | 10.5.0 | R5s141133 |
| RP-66 | RP-142064 | 0246 | - | Re-verification of GCF WI-103 IMS XCAP Supplementary Service Testcase 15.9 over 36.523-3 Test Model | F | 10.4.0 | 10.5.0 | R5s141135 |
| RP-66 | RP-142064 | 0247 | - | Changes to XML templates | F | 10.4.0 | 10.5.0 | R5s141138 |
| RP-66 | RP-142064 | 0248 | - | Verification of IMS test case 15.2 over LTE with 34.229-4 test model | F | 10.4.0 | 10.5.0 | R5s141140 |
| RP-66 | RP-142064 | 0249 | - | Verification of IMS test case 15.13 over LTE with 34.229-4 test model | F | 10.4.0 | 10.5.0 | R5s141142 |
| RP-66 | RP-142064 | 0250 | - | Correction to GCF WI-103 IMS call control test case 12.2a | F | 10.4.0 | 10.5.0 | R5s141154 |
| RP-66 | RP-142064 | 0251 | - | Addition of GCF WI-103 XCAP supplementary service Testcase 15.10a over 36.523-3 Test Model | F | 10.4.0 | 10.5.0 | R5s141162 |
| RP-66 | RP-142063 | 0252 | - | CR to 34.229-3: Add new verified and e-mail agreed TTCN test cases in the TC lists in 34.229-3 (prose), Annex A | F | 10.4.0 | 10.5.0 | RP-142063 |

| Meeting | TSG doc | CR | Rev | Subject | Cat | Old vers | New vers | WG doc |
|---------|-----------|------|-----|---|-----|----------|----------|-----------|
| RP-67 | RP-150332 | 0253 | - | Routine maintenance for TS 34.229-3 | F | 10.5.0 | 10.6.0 | R5-150355 |
| RP-67 | RP-150332 | 0283 | - | CR to 34.229-3: Add new verified and e-mail agreed TTCN test cases in the TC lists in 34.229-3 (prose), Annex A | F | 10.5.0 | 10.6.0 | - |
| RP-67 | RP-150333 | 0254 | - | Addition of GCF WI-154 IMS emergency call testcase 19.3.1 over 36.523-3 Test Model | B | 10.5.0 | 10.6.0 | R5s141155 |
| RP-67 | RP-150333 | 0255 | - | Correction of IMS test case 8.1: sip-instance | F | 10.5.0 | 10.6.0 | R5s141212 |
| RP-67 | RP-150333 | 0256 | - | Addition of GCF WI-198 MO MTSI Video Call test case 12.21 (using 36.523-3 test model) | B | 10.5.0 | 10.6.0 | R5s141221 |
| RP-67 | RP-150333 | 0257 | - | Correction to IMS Emergency call test case 19.4.1 | F | 10.5.0 | 10.6.0 | R5s141232 |
| RP-67 | RP-150333 | 0258 | - | Addition of GCF WI-154 Emergency Call Testcase 19.3.4 over 36.523-3 Test Model | B | 10.5.0 | 10.6.0 | R5s141237 |
| RP-67 | RP-150333 | 0259 | - | Correction of o-lines in SDP bodies sent by SS | F | 10.5.0 | 10.6.0 | R5s141244 |
| RP-67 | RP-150333 | 0260 | - | Correction to GCF WI-171 IMS SSAC test case 12.18 | F | 10.5.0 | 10.6.0 | R5s141273 |
| RP-67 | RP-150333 | 0261 | - | Addition of GCF WI-154 IMS Emergency Call test case 19.1.5 | B | 10.5.0 | 10.6.0 | R5s141286 |
| RP-67 | RP-150333 | 0262 | - | Correction to IMS Registration Procedure | F | 10.5.0 | 10.6.0 | R5s141322 |
| RP-67 | RP-150333 | 0263 | - | Correction to GCF WI-103 IMS test case 11.2 | F | 10.5.0 | 10.6.0 | R5s141326 |
| RP-67 | RP-150333 | 0264 | - | Addition of GCF WI-198 MO MTSI Video Call test case 12.22 over 36.523-3 Test Model | B | 10.5.0 | 10.6.0 | R5s141329 |
| RP-67 | RP-150333 | 0265 | - | Correction to GCF WI-154 IMS emergency test case 19.5.6 and 19.5.7 | F | 10.5.0 | 10.6.0 | R5s141335 |
| RP-67 | RP-150333 | 0266 | - | Correction to GCF WI-198 IMS MO Video Call Testcase 12.21 | F | 10.5.0 | 10.6.0 | R5s141336 |
| RP-67 | RP-150333 | 0267 | - | Correction to GCF WI-154 IMS emergency test case 19.3.4 | F | 10.5.0 | 10.6.0 | R5s141337 |
| RP-67 | RP-150333 | 0268 | - | Addition of GCF WI-103 IMS Conference Call Testcase 15.17 over 36.523-3 Test Model | B | 10.5.0 | 10.6.0 | R5s141341 |
| RP-67 | RP-150333 | 0269 | - | Addition of GCF WI-103 IMS Conference Call Testcase 15.19 over 36.523-3 Test Model | B | 10.5.0 | 10.6.0 | R5s141343 |
| RP-67 | RP-150333 | 0270 | - | Correction of IMS TC 15.10a: not-registered condition | F | 10.5.0 | 10.6.0 | R5s141350 |
| RP-67 | RP-150333 | 0271 | - | Correction to GCF WI-103 IMS 15.x XCAP Testcases | F | 10.5.0 | 10.6.0 | R5s141351 |
| RP-67 | RP-150333 | 0272 | - | Correction of XCAP TCs on usage of str2oct | F | 10.5.0 | 10.6.0 | R5s141353 |
| RP-67 | RP-150333 | 0273 | - | Correction of IMS Emergency Call testcase 19.4.5 | F | 10.5.0 | 10.6.0 | R5s141370 |
| RP-67 | RP-150333 | 0274 | - | Correction of IMS SSAC Testcases 12.18, 12.19, 12.20, 12.18a, 12.19a and 12.20a | F | 10.5.0 | 10.6.0 | R5s141381 |
| RP-67 | RP-150333 | 0275 | - | Correction of prefix to XCAP Root Uri | F | 10.5.0 | 10.6.0 | R5s150030 |
| RP-67 | RP-150333 | 0276 | - | Correction to UPDATE message for IMS MT Call Testcases | F | 10.5.0 | 10.6.0 | R5s150035 |
| RP-67 | RP-150333 | 0277 | - | Correction for record-route header in IMS MT call scenarios | F | 10.5.0 | 10.6.0 | R5s150039 |
| RP-67 | RP-150333 | 0278 | - | Correction to cr_UE_RadioAccessCapability template for IMS UTRA test cases | F | 10.5.0 | 10.6.0 | R5s150054 |
| RP-67 | RP-150333 | 0279 | - | Correction to IMS Multiple PDN | F | 10.5.0 | 10.6.0 | R5s150055 |

| Meeting | TSG doc | CR | Rev | Subject | Cat | Old vers | New vers | WG doc |
|---------|-----------|------|-----|--|-----|----------|----------|-----------|
| RP-67 | RP-150333 | 0280 | - | Correction to DNS Query procedure for IMS Testcases | F | 10.5.0 | 10.6.0 | R5s150085 |
| RP-67 | RP-150333 | 0281 | - | Correction to SessionID in IMS signalling procedures | F | 10.5.0 | 10.6.0 | R5s150086 |
| RP-67 | RP-150333 | 0282 | - | Addition of GCF WI-171 MO MTSI Video Call test case 12.19 (using 36.523-3 test model) | B | 10.5.0 | 10.6.0 | R5s150115 |
| RP-68 | RP-150884 | 0284 | - | Routine maintenance for TS 34.229-3 | F | 10.6.0 | 10.7.0 | R5-151102 |
| RP-68 | RP-150894 | 0286 | - | Corrections to Emergency Services Over IMS test case 19.1.3 | F | 10.6.0 | 10.7.0 | R5s150061 |
| RP-68 | RP-150894 | 0287 | - | Corrections for Emergency Services over IMS test case 19.1.5 | F | 10.6.0 | 10.7.0 | R5s150091 |
| RP-68 | RP-150894 | 0288 | - | Correction to IMS XCAP Testcases | F | 10.6.0 | 10.7.0 | R5s150148 |
| RP-68 | RP-150894 | 0289 | - | Correction of RR and RS modifiers | F | 10.6.0 | 10.7.0 | R5s150153 |
| RP-68 | RP-150894 | 0290 | - | Correction to IMS Emergency Call testcase 19.4.5 | F | 10.6.0 | 10.7.0 | R5s150157 |
| RP-68 | RP-150894 | 0291 | - | Correction to IMS Emergency Call testcase 19.3.1 | F | 10.6.0 | 10.7.0 | R5s150158 |
| RP-68 | RP-150894 | 0292 | - | Correction of SPI matching error at runtime | F | 10.6.0 | 10.7.0 | R5s150174 |
| RP-68 | RP-150894 | 0293 | - | Correction for checking of video feature tag | F | 10.6.0 | 10.7.0 | R5s150180 |
| RP-68 | RP-150894 | 0294 | - | Correction to IMS Emergency Call testcase 19.3.1 | F | 10.6.0 | 10.7.0 | R5s150193 |
| RP-68 | RP-150894 | 0295 | - | Correction to GCF WI-154 IMS Emergency Call testcase 19.5.7 | F | 10.6.0 | 10.7.0 | R5s150195 |
| RP-68 | RP-150894 | 0296 | - | Correction regarding XCAP Root URI | F | 10.6.0 | 10.7.0 | R5s150202 |
| RP-68 | RP-150894 | 0297 | - | Correction to Annex Procedure C.28 | F | 10.6.0 | 10.7.0 | R5s150205 |
| RP-68 | RP-150894 | 0298 | - | Correction in IMS MTSI Video call test case 12.21 | F | 10.6.0 | 10.7.0 | R5s150236 |
| RP-68 | RP-150894 | 0299 | - | Correction of Require header in 200 OK | F | 10.6.0 | 10.7.0 | R5s150237 |
| RP-68 | RP-150894 | 0300 | - | Corrections for upper tester for IMS XCAP call forwarding test cases | F | 10.6.0 | 10.7.0 | R5s150244 |
| RP-68 | RP-150894 | 0301 | - | Corrections for Emergency Services over IMS test case 19.5.7 | F | 10.6.0 | 10.7.0 | R5s150245 |
| RP-68 | RP-150894 | 0302 | - | Addition of GCF WI-103 MTSI Message Waiting Indication test case 15.15 (using 36.523-3 and 34.229-4 test models) | B | 10.6.0 | 10.7.0 | R5s150259 |
| RP-68 | RP-150894 | 0303 | - | Correction of multi-PDN PCO handling | F | 10.6.0 | 10.7.0 | R5s150267 |
| RP-68 | RP-150894 | 0304 | - | Correction for inactivity timer in IMS XCAP test cases | F | 10.6.0 | 10.7.0 | R5s150269 |
| RP-68 | RP-150894 | 0305 | - | Corrections for TCP connection handling for IMS test cases | F | 10.6.0 | 10.7.0 | R5s150270 |
| RP-68 | RP-150894 | 0306 | - | Correction to IMS emergency services test case 19.1.3 | F | 10.6.0 | 10.7.0 | R5s150273 |
| RP-68 | RP-150894 | 0307 | - | Correction of Require header in 200 OK - continued | F | 10.6.0 | 10.7.0 | R5s150274 |
| RP-68 | RP-150894 | 0308 | - | Correction of IMS TC 15.19 | F | 10.6.0 | 10.7.0 | R5s150276 |
| RP-68 | RP-150894 | 0309 | - | Addition of GCF WI-103 IMS XCAP Testcase 15.10 over 36.523-3 Test Model | B | 10.6.0 | 10.7.0 | R5s150289 |
| RP-68 | RP-150894 | 0310 | - | Addition of GCF WI-154 IMS Emergency Call test case 19.4.2 (using 36.523-3 test model) | B | 10.6.0 | 10.7.0 | R5s150327 |
| RP-68 | RP-150894 | 0312 | - | Correction to TC 8.2 on expiration values | F | 10.6.0 | 10.7.0 | R5s150342 |

| Meeting | TSG doc | CR | Rev | Subject | Cat | Old vers | New vers | WG doc |
|---------|-----------|------|-----|--|-----|----------|----------|-----------|
| RP-68 | RP-150894 | 0313 | - | Addition of GCF WI-103 IMS Testcase 15.12a over 36.523-3 Test Model | B | 10.6.0 | 10.7.0 | R5s150371 |
| RP-68 | RP-150894 | 0314 | - | Addition of GCF WI-198 IMS Testcase 15.19a over 36.523-3 Test Model | B | 10.6.0 | 10.7.0 | R5s150373 |
| RP-68 | RP-150894 | 0315 | - | Addition of GCF WI-103 IMS Testcase 15.21a over 36.523-3 Test Model | B | 10.6.0 | 10.7.0 | R5s150382 |
| RP-68 | RP-150894 | 0316 | - | Correction to IMS Emergency Call test case 19.3.1 | F | 10.6.0 | 10.7.0 | R5s150414 |
| RP-68 | RP-150894 | 0317 | - | Correction of IMS TC 8.1 | F | 10.6.0 | 10.7.0 | R5s150446 |
| RP-68 | RP-150893 | 0285 | - | CR to 34.229-3: Add new verified and e-mail agreed TTCN test cases in the TC lists in 34.229-3 (prose), Annex A | F | 10.7.0 | 11.0.0 | - |
| RP-68 | RP-150894 | 0311 | - | IMS type definition updates for rSRVCC | F | 10.7.0 | 11.0.0 | R5s150339 |
| RP-69 | RP-151409 | 0318 | - | Routine maintenance for TS 34.229-3 | F | 11.0.0 | 11.1.0 | R5-153257 |
| RP-69 | RP-151416 | 0319 | - | CR to 34.229-3: Add new verified and e-mail agreed TTCN test cases in the TC lists in 34.229-3 (prose), Annex A | F | 11.0.0 | 11.1.0 | - |
| RP-69 | RP-151417 | 0320 | - | Correction to IMS emergency services test case 19.3.3 with 34.229-3 IPCAN model | F | 11.0.0 | 11.1.0 | R5s150412 |
| RP-69 | RP-151417 | 0321 | - | Addition of IMS test case 8.16 (... using 36.523-3 test model) | F | 11.0.0 | 11.1.0 | R5s150534 |
| RP-69 | RP-151417 | 0322 | - | Correction to IMS video conferencing test case 15.19a | F | 11.0.0 | 11.1.0 | R5s150537 |
| RP-69 | RP-151417 | 0323 | - | Correction for IMS test cases | F | 11.0.0 | 11.1.0 | R5s150630 |
| RP-69 | RP-151417 | 0324 | - | Correction to de-registration sequence for IMS test cases | F | 11.0.0 | 11.1.0 | R5s150647 |
| RP-69 | RP-151417 | 0325 | - | Correction to testcase 13.4.3.26 regarding 200 OK in C.28 | F | 11.0.0 | 11.1.0 | R5s150665 |
| RP-69 | RP-151417 | 0326 | - | Correction to IMS Call forwarding testcase 15.8 | F | 11.0.0 | 11.1.0 | R5s150666 |
| RP-69 | RP-151417 | 0327 | - | Correction to GCF WI-154 IMS emergency Call testcase 19.3.1 | F | 11.0.0 | 11.1.0 | R5s150667 |
| RP-69 | RP-151417 | 0328 | - | Correction to procedure for IPv6 address comparison | F | 11.0.0 | 11.1.0 | R5s150668 |
| RP-69 | RP-151417 | 0329 | - | Addition of IMS test case 20.1 (... using 36.523-3 test model) | F | 11.0.0 | 11.1.0 | R5s150714 |
| RP-69 | RP-151417 | 0330 | - | Correction to XCAP Call Forwarding testcases | F | 11.0.0 | 11.1.0 | R5s150725 |
| RP-69 | RP-151417 | 0331 | - | Addition of IMS video conference call test case 15.21c | F | 11.0.0 | 11.1.0 | R5s150775 |
| RP-69 | - | - | - | update of the "non-specific references" in section 2 according to the approved R5-153582 and an action point on ETSI MCC | - | 11.0.0 | 11.1.0 | - |
| RP-70 | RP-151693 | 0333 | - | Correction to IMS Emergency Call test case 19.3.1 | F | 11.1.0 | 11.2.0 | R5s150692 |
| RP-70 | RP-151693 | 0334 | - | Correction to usage of GRUU in IMS registration | F | 11.1.0 | 11.2.0 | R5s150721 |
| RP-70 | RP-151693 | 0335 | - | Correction to GCF WI-154 IMS emergency Call testcase 19.3.1 | F | 11.1.0 | 11.2.0 | R5s150739 |
| RP-70 | RP-151693 | 0336 | - | Addition of IMS video call test case 15.11a | F | 11.1.0 | 11.2.0 | R5s150755 |
| RP-70 | RP-151693 | 0337 | - | Correction to IMS test case 10.1 | F | 11.1.0 | 11.2.0 | R5s150786 |
| RP-70 | RP-151693 | 0338 | - | Correction to IMS emergency test case 19.5.7 | F | 11.1.0 | 11.2.0 | R5s150809 |

| Meeting | TSG doc | CR | Rev | Subject | Cat | Old vers | New vers | WG doc |
|---------|-----------|------|-----|---|-----|----------|----------|---------------------------|
| RP-70 | RP-151693 | 0339 | - | Correction to initiation of Emergency Calls | F | 11.1.0 | 11.2.0 | R5s150817 |
| RP-70 | RP-151693 | 0340 | - | Correction to IMS Emergency Call Test Case 19.1.5 | F | 11.1.0 | 11.2.0 | R5s150818 |
| RP-70 | RP-151693 | 0341 | - | Correction to IMS Registration | F | 11.1.0 | 11.2.0 | R5s150835 |
| RP-70 | RP-151693 | 0342 | - | Correction to MTSI MO speech call procedures in AnnexC21 | F | 11.1.0 | 11.2.0 | R5s150841 |
| RP-70 | RP-151693 | 0343 | - | Correction to common IMS functions to handling IMS Dialogs | F | 11.1.0 | 11.2.0 | R5s150843 |
| RP-70 | RP-151693 | 0344 | - | Correction to usage of Max-Forwards | F | 11.1.0 | 11.2.0 | R5s150850 |
| RP-70 | RP-151693 | 0345 | - | Corrections to IMS emergency test case 19.3.1 | F | 11.1.0 | 11.2.0 | R5s150851 |
| RP-70 | RP-151693 | 0346 | - | Correction to number of SIP dialogs | F | 11.1.0 | 11.2.0 | R5s150854 |
| RP-70 | RP-151693 | 0347 | - | Correction in IMS Emergency Call test case 19.5.7 | F | 11.1.0 | 11.2.0 | R5s150864 |
| RP-70 | RP-151693 | 0348 | - | Corrections to RTP and RTCP handling | F | 11.1.0 | 11.2.0 | R5s150865 |
| RP-70 | RP-151693 | 0349 | - | Corrections to IMS Emergency call Testcase 19.1.3 | F | 11.1.0 | 11.2.0 | R5s150868 |
| RP-70 | RP-151693 | 0350 | - | Corrections to IMS authentication test cases 9.1 and 9.2 | F | 11.1.0 | 11.2.0 | R5s150873 |
| RP-70 | RP-151693 | 0351 | - | Correction to IMS registration expiry time | F | 11.1.0 | 11.2.0 | R5s150886 |
| RP-70 | RP-151693 | 0352 | - | Correction to IMS REGISTER message | F | 11.1.0 | 11.2.0 | R5s150888 |
| RP-70 | RP-151693 | 0353 | - | Correction to Emergency Call Normal Services in 34.229-1 | F | 11.1.0 | 11.2.0 | R5s150900 |
| RP-70 | RP-151693 | 0354 | - | Corrections to usage of GRUU | F | 11.1.0 | 11.2.0 | R5s150908 |
| RP-70 | RP-151693 | 0355 | - | Corrections to IMS three-way session creation test cases | F | 11.1.0 | 11.2.0 | R5s150909 |
| RP-70 | RP-151693 | 0356 | - | Correction to GCF WI-103 15.21a Three way session testcase | F | 11.1.0 | 11.2.0 | R5s150910 |
| RP-70 | RP-151693 | 0357 | - | Correction to postamble for test cases 6.3 and 7.1 | F | 11.1.0 | 11.2.0 | R5s150919 |
| RP-70 | RP-151693 | 0358 | - | Correction to IMS emergency test case 19.5.6 | F | 11.1.0 | 11.2.0 | R5s150972 |
| RP-70 | RP-151692 | 0359 | - | CR to 34.229-3: Add new verified and e-mail agreed TTCN test cases in the TC lists in 34.229-3 (prose), Annex A | F | 11.1.0 | 11.2.0 | - |
| RP-71 | RP-160117 | 0382 | 1 | Routine maintenance for TS 34.229-3 | F | 11.2.0 | 11.3.0 | R5-160912 |
| RP-71 | RP-160123 | 0362 | - | Correction to IMS test case 15.21a regarding Route header in REFER | F | 11.2.0 | 11.3.0 | R5s160011 |
| RP-71 | RP-160123 | 0365 | - | Corrections to IMS emergency call test case 19.4.1 | F | 11.2.0 | 11.3.0 | R5s160031 |
| RP-71 | RP-160123 | 0366 | - | Corrections to IMS IRAT Emergency Call Limited Service Functionality | F | 11.2.0 | 11.3.0 | R5s160032 |
| RP-71 | RP-160123 | 0367 | - | Correction to IMS test case 15.21a regarding TEL URI | F | 11.2.0 | 11.3.0 | R5s160043 |
| RP-71 | RP-160123 | 0368 | - | Correction to Unsubscribe function in IMS De-Registration procedure | F | 11.2.0 | 11.3.0 | R5s160045 |
| RP-71 | RP-160123 | 0369 | - | Corrections to bit rate for video calls | F | 11.2.0 | 11.3.0 | R5s160046 |
| RP-71 | RP-160123 | 0371 | - | Correction to NOTIFY for 200 OK in Conferencing test cases | B | 11.2.0 | 11.3.0 | R5s160055 |
| RP-71 | RP-160123 | 0373 | - | Addition of test case 19.3.2b | B | 11.2.0 | 11.3.0 | R5s160070 |

| Meeting | TSG doc | CR | Rev | Subject | Cat | Old vers | New vers | WG doc |
|---------|-----------|------|-----|---|-----|----------|----------|---------------------------|
| RP-71 | RP-160123 | 0375 | - | Addition of test case 19.3.2c | F | 11.2.0 | 11.3.0 | R5s160072 |
| RP-71 | RP-160123 | 0377 | - | Correction to IMS test case 8.16 | B | 11.2.0 | 11.3.0 | R5s160075 |
| RP-71 | RP-160123 | 0378 | - | Addition of test case 19.3.2 | F | 11.2.0 | 11.3.0 | R5s160076 |
| RP-71 | RP-160123 | 0381 | - | Correction to IMS_UTRAN_IWD_15wk50 test suite | B | 11.2.0 | 11.3.0 | R5s160090 |
| RP-71 | RP-160123 | 0363 | 1 | Addition of IMS test case 15.14b | B | 11.2.0 | 11.3.0 | R5s160096 |
| RP-71 | RP-160123 | 0384 | - | Addition of IMS test case 19.5.1 | F | 11.2.0 | 11.3.0 | R5s160131 |
| RP-71 | RP-160123 | 0387 | - | Correction to IMS test case 15.11 regarding Geolocation header | B | 11.2.0 | 11.3.0 | R5s150846 |
| RP-71 | RP-160123 | 0388 | - | Addition of IMS test case 15.29 | F | 11.2.0 | 11.3.0 | R5s150945 |
| RP-71 | RP-160123 | 0389 | - | Correction to IMS test case 15.10 | F | 11.2.0 | 11.3.0 | R5s150965 |
| RP-71 | RP-160123 | 0390 | - | Corrections to fl_SIP_ParseURI for tel uri with phone context | F | 11.2.0 | 11.3.0 | R5s150968 |
| RP-71 | RP-160123 | 0391 | - | Correction to f_URL_Decoding | F | 11.2.0 | 11.3.0 | R5s151006 |
| RP-71 | RP-160122 | 0385 | - | CR to 34.229-3: Add new verified and e-mail agreed TTCN test cases in the TC lists in 34.229-3 (prose), Annex A | F | 11.2.0 | 11.3.0 | R5s160177 |
| RP-72 | RP-160845 | 0406 | - | Routine maintenance for TS 34.229-3 | F | 11.3.0 | 11.4.0 | R5-162025 |
| RP-72 | RP-160849 | 0400 | - | Correction to GCF WI-154 IMS emergency call TC 19.5.1 | F | 11.3.0 | 11.4.0 | R5s160313 |
| RP-72 | RP-160849 | 0401 | - | Correction to host name in Temp GRUU returned in 200 OK for REGISTER | F | 11.3.0 | 11.4.0 | R5s160324 |
| RP-72 | RP-160849 | 0402 | - | Corrections to GRUU in XML body of NOTIFY request | F | 11.3.0 | 11.4.0 | R5s160325 |
| RP-72 | RP-160849 | 0403 | - | Correction to authentication method used in XCAP test cases | F | 11.3.0 | 11.4.0 | R5s160338 |
| RP-72 | RP-160849 | 0404 | - | Correction to IMS emergency call test cases 19.1.3, 19.3.2, 19.3.2b | F | 11.3.0 | 11.4.0 | R5s160339 |
| RP-72 | RP-160849 | 0405 | - | Correction to XCAP encoding rules | F | 11.3.0 | 11.4.0 | R5s160353 |
| RP-72 | RP-160849 | 0407 | - | Corrections to Contact header of MO INVITE | F | 11.3.0 | 11.4.0 | R5s160366 |
| RP-72 | RP-160849 | 0410 | - | Addition of IMS EVS test case 12.23 | F | 11.3.0 | 11.4.0 | R5s160379 |
| RP-72 | RP-160849 | 0411 | - | Addition of IMS EVS test case 12.25 | F | 11.3.0 | 11.4.0 | R5s160381 |
| RP-72 | RP-160849 | 0413 | - | Correction to emergency call Testcases 19.3.2, 19.3.2b and 19.3.2c | F | 11.3.0 | 11.4.0 | R5s160406 |
| RP-72 | RP-160849 | 0416 | - | Correction to IMS emergency call test case 19.5.1 | F | 11.3.0 | 11.4.0 | R5s160439 |
| RP-72 | RP-160849 | 0417 | - | Correction to XCAP GBA authentication procedure. | F | 11.3.0 | 11.4.0 | R5s160442 |
| RP-72 | RP-160849 | 0383 | 1 | Corrections to IMS-IRAT Emergency Call test case 19.4.2 | F | 11.3.0 | 11.4.0 | R5s160460 |
| RP-72 | RP-160849 | 0392 | 1 | Correction to IMS Emergency Call test case 19.1.5 | F | 11.3.0 | 11.4.0 | R5s160472 |
| RP-72 | RP-160849 | 0394 | 1 | Correction to encoding for SipUrl type | F | 11.3.0 | 11.4.0 | R5s160490 |
| RP-72 | RP-160849 | 0396 | 1 | Correction for IMS video call test cases | F | 11.3.0 | 11.4.0 | R5s160502 |
| RP-72 | RP-160849 | 0398 | 1 | Corrections for IMS emergency call test cases 19.1.3, 19.3.2, 19.3.2b and 19.3.2c | F | 11.3.0 | 11.4.0 | R5s160514 |
| RP-72 | RP-160849 | 0399 | 1 | Correction of fl_SIP_BuildReferToUri_RX | F | 11.3.0 | 11.4.0 | R5s160516 |

| Meeting | TSG doc | CR | Rev | Subject | Cat | Old vers | New vers | WG doc |
|---------|-----------|------|-----|--|-----|----------|----------|---------------------------|
| RP-72 | RP-160848 | 0421 | - | Add new verified and e-mail agreed TTCN test cases in the TC lists in 34.229-3 (prose), Annex A | F | 11.4.0 | 12.0.0 | R5s160457 |
| RP-73 | RP-161426 | 0441 | - | Routine maintenance for TS 34.229-3 | F | 12.0.0 | 12.1.0 | R5-165259 |
| RP-73 | RP-161397 | 0442 | - | MTSI over WLAN: Introduction of Test Model | F | 12.0.0 | 12.1.0 | R5-165261 |
| RP-73 | RP-161396 | 0443 | - | MTSI over fixed access: Introduction of Test Model | F | 12.0.0 | 12.1.0 | R5-165262 |
| RP-73 | RP-161430 | 0431 | - | Correction to Recv-Info header checking in MO INVITE | F | 12.0.0 | 12.1.0 | R5s160616 |
| RP-73 | RP-161430 | 0434 | - | Correction of fl_Authorization_GBA | F | 12.0.0 | 12.1.0 | R5s160642 |
| RP-73 | RP-161430 | 0435 | - | Correction to applicability of IMS EVS test cases | F | 12.0.0 | 12.1.0 | R5s160645 |
| RP-73 | RP-161430 | 0418 | 2 | Correction of URIs used in From and To headers | F | 12.0.0 | 12.1.0 | R5s160655 |
| RP-73 | RP-161430 | 0420 | 1 | Correction to XML encoding of SIP instance ID for GRUU | F | 12.0.0 | 12.1.0 | R5s160656 |
| RP-73 | RP-161430 | 0422 | 1 | Correction to IMS test case 19.5.1 for Multi-PDN configured UE's | F | 12.0.0 | 12.1.0 | R5s160658 |
| RP-73 | RP-161430 | 0424 | 1 | Corrections to fl_HTTP_AuthenticationMethod | F | 12.0.0 | 12.1.0 | R5s160665 |
| RP-73 | RP-161430 | 0426 | 1 | Corrections to IMS Emergency Call test case 19.4.5 | F | 12.0.0 | 12.1.0 | R5s160669 |
| RP-73 | RP-161430 | 0427 | 1 | Correction to GCF WI-103 IMS TC 11.1 | F | 12.0.0 | 12.1.0 | R5s160674 |
| RP-73 | RP-161430 | 0436 | - | Addition of IMS Supplementary Services test case 15.2a | B | 12.0.0 | 12.1.0 | R5s160687 |
| RP-73 | RP-161430 | 0438 | - | Corrections for GBA authentication | F | 12.0.0 | 12.1.0 | R5s160710 |
| RP-73 | RP-161430 | 0444 | - | Correction and simplification of the release of security contexts for IMS | F | 12.0.0 | 12.1.0 | R5s160735 |
| RP-73 | RP-161430 | 0445 | - | Correction for IMS test case initialisation | F | 12.0.0 | 12.1.0 | R5s160736 |
| RP-73 | RP-161430 | 0446 | - | Correction for IMS test cases | F | 12.0.0 | 12.1.0 | R5s160737 |
| RP-73 | RP-161430 | 0448 | - | Corrections to IMS IRAT emergency call test cases 19.1.3, 19.3.2, 19.3.2b, 19.3.2c | F | 12.0.0 | 12.1.0 | R5s160754 |
| RP-73 | RP-161430 | 0414 | 2 | Correction to IMS test case 15.11a on assigning the value of Logical Channel Priority for DRB-AM EPS bearers | F | 12.0.0 | 12.1.0 | R5s160804 |
| RP-73 | RP-161430 | 0415 | 2 | Addition of IMS test case 19.5.8 | B | 12.0.0 | 12.1.0 | R5s160805 |
| RP-73 | RP-161430 | 0423 | 2 | Addition of IMS test case 17.2 | B | 12.0.0 | 12.1.0 | R5s160806 |
| RP-73 | RP-161430 | 0428 | 2 | Correction to IMS Conference call test case 15.17 | F | 12.0.0 | 12.1.0 | R5s160807 |
| RP-73 | RP-161430 | 0429 | 2 | Addition of IMS test case 17.1 | B | 12.0.0 | 12.1.0 | R5s160808 |
| RP-73 | RP-161429 | 0449 | - | Add new verified and e-mail agreed TTCN test cases in the TC lists in 34.229-3 (prose), Annex A | F | 12.0.0 | 12.1.0 | R5s160803 |
| RP-73 | RP-161430 | 0440 | - | Rel-13 baseline upgrade for IMS Test Suites | F | 12.1.0 | 13.0.0 | R5s160714 |
| RP-74 | RP-162106 | 0457 | - | Corrections to IMS test case 17.2 | F | 13.0.0 | 13.1.0 | R5s160842 |
| RP-74 | RP-162106 | 0458 | - | Correction to IMS Mobile Originated Call test cases | F | 13.0.0 | 13.1.0 | R5s160855 |
| RP-74 | RP-162106 | 0459 | - | Correction to GCF WI-154 IMS Emergency Call test case 19.3.2 | F | 13.0.0 | 13.1.0 | R5s160856 |
| RP-74 | RP-162106 | 0460 | - | Correcting the applicability check of IMS test case 19.5.8 | F | 13.0.0 | 13.1.0 | R5s160862 |
| RP-74 | RP-162106 | 0461 | - | Correction to CDU AT Command for IMS Video Call Establishment | F | 13.0.0 | 13.1.0 | R5s160879 |
| RP-74 | RP-162106 | 0450 | 1 | Correction to GCF WI-154 IMS Emergency Call testcase 19.5.1 | F | 13.0.0 | 13.1.0 | R5s160916 |

| Meeting | TSG doc | CR | Rev | Subject | Cat | Old vers | New vers | WG doc |
|---------|-----------|------|-----|---|-----|----------|----------|---------------------------|
| RP-74 | RP-162106 | 0451 | 1 | Correction for HTTP authentication | F | 13.0.0 | 13.1.0 | R5s160923 |
| RP-74 | RP-162106 | 0452 | 1 | Correction to IP PTC altstep a_IP_IMS_Config() | F | 13.0.0 | 13.1.0 | R5s160925 |
| RP-74 | RP-162106 | 0453 | 1 | Correction to cr_ReferTo template as used in IMS Conferencing test cases | F | 13.0.0 | 13.1.0 | R5s160927 |
| RP-74 | RP-162106 | 0455 | 1 | Correction to postamble procedure for IMS XCAP Testcases | F | 13.0.0 | 13.1.0 | R5s160931 |
| RP-74 | RP-162106 | 0454 | 1 | Correction to Authentication-Info header used in fl_AuthenticationInfo_GBA | F | 13.0.0 | 13.1.0 | R5s160962 |
| RP-75 | RP-170095 | 0475 | - | Routine maintenance for TS 34.229-3 | F | 13.1.0 | 13.2.0 | R5-170558 |
| RP-75 | RP-170099 | 0468 | - | Correction to GCF WI-154 IMS Emergency Call test case 19.1.3 | F | 13.1.0 | 13.2.0 | R5s170044 |
| RP-75 | RP-170099 | 0469 | - | Correction for IMS conferencing test cases | F | 13.1.0 | 13.2.0 | R5s170046 |
| RP-75 | RP-170099 | 0470 | - | Correction for IMS authentication test case 9.1 and 9.2 | F | 13.1.0 | 13.2.0 | R5s170050 |
| RP-75 | RP-170099 | 0471 | - | Correction for IMS video call test case 12.22 | F | 13.1.0 | 13.2.0 | R5s170056 |
| RP-75 | RP-170099 | 0472 | - | Addition of IMS test case 12.24 | B | 13.1.0 | 13.2.0 | R5s170066 |
| RP-75 | RP-170099 | 0473 | - | Addition of IMS test case 12.26 | B | 13.1.0 | 13.2.0 | R5s170074 |
| RP-75 | RP-170099 | 0474 | - | Addition of IMS test case 15.4a | B | 13.1.0 | 13.2.0 | R5s170078 |
| RP-75 | RP-170099 | 0476 | - | Removing temp-gruu from Contact header for IMS emergency registration | F | 13.1.0 | 13.2.0 | R5s170098 |
| RP-75 | RP-170099 | 0477 | - | Adding P-Access-Network-Info header to fl_IMS_PrackRequest_MessageHeaderRX() | F | 13.1.0 | 13.2.0 | R5s170099 |
| RP-75 | RP-170099 | 0462 | 1 | Correction for AT command used in IMS Call forwarding Supplementary Service test cases | F | 13.1.0 | 13.2.0 | R5s170108 |
| RP-75 | RP-170099 | 0463 | 1 | Correction to IMS Emergency call test case 19.5.6 | F | 13.1.0 | 13.2.0 | R5s170112 |
| RP-75 | RP-170099 | 0464 | 1 | Correction for IMS XCAP test cases using GBA Authentication | F | 13.1.0 | 13.2.0 | R5s170122 |
| RP-75 | RP-170099 | 0465 | 1 | Correction to IMS Emergency Registration test case 19.5.9 | F | 13.1.0 | 13.2.0 | R5s170143 |
| RP-75 | RP-170099 | 0467 | 1 | Correction to WI-198 test case 17.2 | F | 13.1.0 | 13.2.0 | R5s170148 |
| RP-75 | RP-170099 | 0466 | 1 | Correction to WI-198 test case 17.1 | F | 13.1.0 | 13.2.0 | R5s170166 |
| RP-75 | RP-170098 | 0482 | - | Add new verified and e-mail agreed TTCN test cases in the TC lists in 34.229-3 (prose), Annex A | F | 13.1.0 | 13.2.0 | R5s170184 |
| RP-76 | RP-171363 | 0494 | - | Routine maintenance for TS 34.229-3 | F | 13.2.0 | 13.3.0 | R5-172048 |
| RP-76 | RP-171367 | 0486 | - | Correction to Annex C.11, C.26, C.45 and C.51 | F | 13.2.0 | 13.3.0 | R5s170228 |
| RP-76 | RP-171367 | 0487 | - | Corrections to IMS test case 12.2a | F | 13.2.0 | 13.3.0 | R5s170231 |
| RP-76 | RP-171367 | 0488 | - | Further corrections to IMS test case 12.26 | F | 13.2.0 | 13.3.0 | R5s170232 |
| RP-76 | RP-171367 | 0489 | - | Correction for IMS authentication test cases 9.x | F | 13.2.0 | 13.3.0 | R5s170297 |
| RP-76 | RP-171367 | 0490 | - | Correction for IMS video call test cases | F | 13.2.0 | 13.3.0 | R5s170299 |
| RP-76 | RP-171367 | 0491 | - | Correction to SessionID in IMS signalling procedures | F | 13.2.0 | 13.3.0 | R5s170305 |
| RP-76 | RP-171367 | 0493 | - | Correction for IMS emergency call test cases | F | 13.2.0 | 13.3.0 | R5s170327 |
| RP-76 | RP-171367 | 0495 | - | Correction for IMS EVS test cases | F | 13.2.0 | 13.3.0 | R5s170336 |
| RP-76 | RP-171367 | 0496 | - | Correction to GCF WI-198 IMS MTSI video Test Case 17.1 | F | 13.2.0 | 13.3.0 | R5s170344 |
| RP-76 | RP-171367 | 0497 | - | Correction to function fl_IMS_Server_SecurityContextCloseTCP | F | 13.2.0 | 13.3.0 | R5s170346 |
| RP-76 | RP-171367 | 0479 | 1 | Correction to function fl_SS_CallForward | F | 13.2.0 | 13.3.0 | R5s170377 |
| RP-76 | RP-171367 | 0480 | 1 | Correction to GCF WI-154 emergency call TC 19.5.8 | F | 13.2.0 | 13.3.0 | R5s170378 |
| RP-76 | RP-171367 | 0483 | 1 | Addition of IMS test case 8.15 | B | 13.2.0 | 13.3.0 | R5s170390 |

| Meet- ing | TSG doc | CR | Rev | Subject | Cat | Old vers | New vers | WG doc |
|--------------|-----------|------|-----|---|-----|-------------|-------------|---------------------------|
| RP-76 | RP-171367 | 0484 | 1 | Correction to Remove security context procedure | F | 13.2.0 | 13.3.0 | R5s170391 |
| RP-76 | RP-171366 | 0500 | - | Add new verified and e-mail agreed TTCN test cases in the TC lists in 34.229-3 (prose), Annex A | F | 13.2.0 | 13.3.0 | R5s170415 |
| RP-76 | RP-171367 | 0481 | 1 | Introduction of PIXIT for SPI calculation | F | 13.2.0 | 13.3.0 | R5s170417 |
| RP-76 | RP-171367 | 0485 | 1 | Corrections to 180 Ringing | F | 13.2.0 | 13.3.0 | R5s170418 |
| RP-77 | RP-171688 | 0513 | 1 | Routine maintenance for TS 34.229-3 | F | 13.3.0 | 13.4.0 | R5-174564 |
| RP-77 | RP-171692 | 0507 | - | Correction for UTRAN IMS test case 6.3 and 7.1 | F | 13.3.0 | 13.4.0 | R5s170541 |
| RP-77 | RP-171692 | 0508 | - | Correction to function fl_IMS_PTC_SPI_ValidValueList_Init() | F | 13.3.0 | 13.4.0 | R5s170544 |
| RP-77 | RP-171692 | 0509 | - | Correction to IMS test cases 19.4.6 and 19.4.7 | F | 13.3.0 | 13.4.0 | R5s170554 |
| RP-77 | RP-171692 | 0510 | - | Correction to function to GCF WI-103 IMS TCs 16.2, 16.3 and 16.4 | F | 13.3.0 | 13.4.0 | R5s170578 |
| RP-77 | RP-171692 | 0514 | - | Correction to function fl_IMS_Server_GetServerAddrRx() | F | 13.3.0 | 13.4.0 | R5s170604 |
| RP-77 | RP-171692 | 0498 | 1 | Addition of IMS test case 19.4.6 | B | 13.3.0 | 13.4.0 | R5s170614 |
| RP-77 | RP-171692 | 0499 | 1 | Addition of IMS test case 19.4.7 | B | 13.3.0 | 13.4.0 | R5s170615 |
| RP-77 | RP-171692 | 0501 | 1 | Correction to bandwidth used in IMS test case 12.23 | F | 13.3.0 | 13.4.0 | R5s170622 |
| RP-77 | RP-171692 | 0502 | 1 | Correction of f_IMS_BuildSDP_MOCallAudioVideo_Step4 | F | 13.3.0 | 13.4.0 | R5s170626 |
| RP-77 | RP-171692 | 0503 | 1 | Correction for IMS deregistration procedure | F | 13.3.0 | 13.4.0 | R5s170643 |
| RP-77 | RP-171692 | 0505 | 1 | Correction to SPI initialization | F | 13.3.0 | 13.4.0 | R5s170645 |
| RP-77 | RP-171692 | 0504 | 1 | Addition of IMS test case G.8.1 | B | 13.3.0 | 13.4.0 | R5s170690 |
| RP-77 | RP-171691 | 0516 | - | Add new verified and e-mail agreed TTCN test cases in the TC lists in 34.229-3 (prose), Annex A | F | 13.3.0 | 13.4.0 | R5s170705 |

History

| Document history | | |
|-------------------------|---------------|-------------|
| V13.0.0 | November 2016 | Publication |
| V13.1.0 | January 2017 | Publication |
| V13.2.0 | April 2017 | Publication |
| V13.3.0 | July 2017 | Publication |
| V13.4.0 | October 2017 | Publication |