

ETSI TS 135 202 V13.0.0 (2016-01)



**Universal Mobile Telecommunications System (UMTS);
LTE;
3G Security;
Specification of the 3GPP confidentiality and
integrity algorithms;
Document 2: Kasumi specification
(3GPP TS 35.202 version 13.0.0 Release 13)**



Reference

RTS/TSGS-0335202vd00

Keywords

LTE,SECURITY,UMTS

ETSI

650 Route des Lucioles
F-06921 Sophia Antipolis Cedex - FRANCE

Tel.: +33 4 92 94 42 00 Fax: +33 4 93 65 47 16

Siret N° 348 623 562 00017 - NAF 742 C
Association à but non lucratif enregistrée à la
Sous-Préfecture de Grasse (06) N° 7803/88

Important notice

The present document can be downloaded from:
<http://www.etsi.org/standards-search>

The present document may be made available in electronic versions and/or in print. The content of any electronic and/or print versions of the present document shall not be modified without the prior written authorization of ETSI. In case of any existing or perceived difference in contents between such versions and/or in print, the only prevailing document is the print of the Portable Document Format (PDF) version kept on a specific network drive within ETSI Secretariat.

Users of the present document should be aware that the document may be subject to revision or change of status. Information on the current status of this and other ETSI documents is available at
<http://portal.etsi.org/tb/status/status.asp>

If you find errors in the present document, please send your comment to one of the following services:
<https://portal.etsi.org/People/CommitteeSupportStaff.aspx>

Copyright Notification

No part may be reproduced or utilized in any form or by any means, electronic or mechanical, including photocopying and microfilm except as authorized by written permission of ETSI.

The content of the PDF version shall not be modified without the written authorization of ETSI.
The copyright and the foregoing restriction extend to reproduction in all media.

© European Telecommunications Standards Institute 2016.
All rights reserved.

DECT™, **PLUGTESTS™**, **UMTS™** and the ETSI logo are Trade Marks of ETSI registered for the benefit of its Members.
3GPP™ and **LTE™** are Trade Marks of ETSI registered for the benefit of its Members and of the 3GPP Organizational Partners.
GSM® and the GSM logo are Trade Marks registered and owned by the GSM Association.

Intellectual Property Rights

IPRs essential or potentially essential to the present document may have been declared to ETSI. The information pertaining to these essential IPRs, if any, is publicly available for **ETSI members and non-members**, and can be found in ETSI SR 000 314: *"Intellectual Property Rights (IPRs); Essential, or potentially Essential, IPRs notified to ETSI in respect of ETSI standards"*, which is available from the ETSI Secretariat. Latest updates are available on the ETSI Web server (<https://ipr.etsi.org/>).

Pursuant to the ETSI IPR Policy, no investigation, including IPR searches, has been carried out by ETSI. No guarantee can be given as to the existence of other IPRs not referenced in ETSI SR 000 314 (or the updates on the ETSI Web server) which are, or may be, or may become, essential to the present document.

Foreword

This Technical Specification (TS) has been produced by ETSI 3rd Generation Partnership Project (3GPP).

The present document may refer to technical specifications or reports using their 3GPP identities, UMTS identities or GSM identities. These should be interpreted as being references to the corresponding ETSI deliverables.

The cross reference between GSM, UMTS, 3GPP and ETSI identities can be found under <http://webapp.etsi.org/key/queryform.asp>.

Modal verbs terminology

In the present document "**shall**", "**shall not**", "**should**", "**should not**", "**may**", "**need not**", "**will**", "**will not**", "**can**" and "**cannot**" are to be interpreted as described in clause 3.2 of the [ETSI Drafting Rules](#) (Verbal forms for the expression of provisions).

"**must**" and "**must not**" are **NOT** allowed in ETSI deliverables except when used in direct citation.

Contents

Intellectual Property Rights	2
Foreword.....	2
Modal verbs terminology.....	2
Foreword.....	4
Introduction	4
0 Scope	6
NORMATIVE SECTION	7
1 Outline of the normative part	8
1.1 References	8
2 Introductory information	8
2.1 Introduction	8
2.2 Notation.....	9
2.2.1 Radix.....	9
2.2.2 Bit/Byte ordering	9
2.2.3 Conventions	9
2.2.4 Subfunctions	9
2.2.5 List of Symbols.....	10
2.3 List of Functions and Variables.....	10
3 KASUMI operation	10
3.1 Introduction	10
3.2 Encryption	11
4 Components of KASUMI.....	11
4.1 Function f_i	11
4.2 Function FL	11
4.3 Function FO	12
4.4 Function FI	12
4.5 S-boxes	13
4.5.1 S_7	13
4.5.2 S_9	14
4.6 Key Schedule.....	15
INFORMATIVE SECTION.....	17
Annex 1 (informative): Figures of the KASUMI Algorithm.....	18
Annex 2 (informative): Simulation Program Listing	20
Annex 3 (informative): Change history	24
History	25

Foreword

This Technical Specification has been produced by the 3rd Generation Partnership Project (3GPP).

The 3GPP Confidentiality and Integrity Algorithms f8 & f9 have been developed through the collaborative efforts of the European Telecommunications Standards Institute (ETSI), the Association of Radio Industries and Businesses (ARIB), the Telecommunications Technology Association (TTA), the T1 Committee.

The f8 & f9 Algorithms Specifications may be used only for the development and operation of 3G Mobile Communications and services. Every Beneficiary must sign a Restricted Usage Undertaking with the Custodian and demonstrate that he fulfills the approval criteria specified in the Restricted Usage Undertaking.

Furthermore, Mitsubishi Electric Corporation holds essential patents on the Algorithms. The Beneficiary must get a separate IPR License Agreement from Mitsubishi Electronic Corporation Japan.

For details of licensing procedures, contact ETSI, ARIB, TTA or T1.

The contents of the present document are subject to continuing work within the TSG and may change following formal TSG approval. Should the TSG modify the contents of the present document, it will be re-released by the TSG with an identifying change of release date and an increase in version number as follows:

Version x.y.z

where:

- x the first digit:
 - 1 presented to TSG for information;
 - 2 presented to TSG for approval;
 - 3 or greater indicates TSG approved document under change control.
- y the second digit is incremented for all changes of substance, i.e. technical enhancements, corrections, updates, etc.
- z the third digit is incremented when editorial only changes have been incorporated in the document.

Introduction

This specification has been prepared by the 3GPP Task Force, and gives a detailed specification of the 3GPP Algorithm KASUMI. KASUMI is a block cipher that forms the heart of the 3GPP confidentiality algorithm *f8*, and the 3GPP integrity algorithm *f9*.

This document is the second of four, which between them form the entire specification of the 3GPP Confidentiality and Integrity Algorithms:

- 3GPP TS 35.201: "3rd Generation Partnership Project; Technical Specification Group Services and System Aspects; 3G Security; Specification of the 3GPP Confidentiality and Integrity Algorithms; Document 1: *f8* and *f9* Specification".
- **3GPP TS 35.202: "3rd Generation Partnership Project; Technical Specification Group Services and System Aspects; 3G Security; Specification of the 3GPP Confidentiality and Integrity Algorithms; Document 2: KASUMI Specification".**
- 3GPP TS 35.203: "3rd Generation Partnership Project; Technical Specification Group Services and System Aspects; 3G Security; Specification of the 3GPP Confidentiality and Integrity Algorithms; Document 3: Implementors' Test Data".

- 3GPP TS 35.204: "3rd Generation Partnership Project; Technical Specification Group Services and System Aspects; 3G Security; Specification of the 3GPP Confidentiality and Integrity Algorithms; Document 4: Design Conformance Test Data".

The normative part of the specification of **KASUMI** is in the main body of this document. The annexes to this document are purely informative. Annex 1 contains illustrations of functional elements of the algorithm, while Annex 2 contains an implementation program listing of the cryptographic algorithm specified in the main body of this document, written in the programming language C.

Similarly the normative part of the specification of the *f8* (confidentiality) and the *f9* (integrity) algorithms is in the main body of Document 1. The annexes of those documents, and Documents 3 and 4 above, are purely informative.

0 Scope

This specification gives a detailed specification of the 3GPP Algorithm KASUMI. KASUMI is a block cipher that forms the heart of the 3GPP confidentiality algorithm *f8*, and the 3GPP integrity algorithm *f9*.

NORMATIVE SECTION

This part of the document contains the normative specification of the KASUMI algorithm.

1 Outline of the normative part

Section 2 introduces the algorithm and describes the notation used in the subsequent sections.

Section 3 defines the algorithm structure and its operation.

Section 4 defines the basic components of the algorithm.

1.1 References

The following documents contain provisions which, through reference in this text, constitute provisions of the present document.

- References are either specific (identified by date of publication, edition number, version number, etc.) or non-specific.
- For a specific reference, subsequent revisions do not apply.
- For a non-specific reference, the latest version applies. In the case of a reference to a 3GPP document (including a GSM document), a non-specific reference implicitly refers to the latest version of that document *in the same Release as the present document*.

- [1] 3GPP TS 33.102 version 3.2.0: "3rd Generation Partnership Project; Technical Specification Group Services and System Aspects; 3G Security; Security Architecture".
- [2] 3GPP TS 33.105 version 3.1.0: "3rd Generation Partnership Project; Technical Specification Group Services and System Aspects; 3G Security; Cryptographic Algorithm Requirements".
- [3] 3GPP TS 35.201: "3rd Generation Partnership Project; Technical Specification Group Services and System Aspects; 3G Security; Specification of the 3GPP Confidentiality and Integrity Algorithms; Document 1: f8 and f9 Specification".
- [4] 3GPP TS 35.202: "3rd Generation Partnership Project; Technical Specification Group Services and System Aspects; 3G Security; Specification of the 3GPP Confidentiality and Integrity Algorithms; Document 2: KASUMI Specification".
- [5] 3GPP TS 35.203: "3rd Generation Partnership Project; Technical Specification Group Services and System Aspects; 3G Security; Specification of the 3GPP Confidentiality and Integrity Algorithms; Document 3: Implementors' Test Data".
- [6] 3GPP TS 35.204: "3rd Generation Partnership Project; Technical Specification Group Services and System Aspects; 3G Security; Specification of the 3GPP Confidentiality and Integrity Algorithms; Document 4: Design Conformance Test Data".
- [7] ISO/IEC 9797-1:1999: "Information technology – Security techniques – Message Authentication Codes (MACs)".

2 Introductory information

2.1 Introduction

Within the security architecture of the 3GPP system there are two standardised algorithms: A confidentiality algorithm *f8*, and an integrity algorithm *f9*. These algorithms are fully specified in a companion document[3]. Each of these algorithms is based on the **KASUMI** algorithm that is specified here.

KASUMI is a block cipher that produces a 64-bit output from a 64-bit input under the control of a 128-bit key.

2.2 Notation

2.2.1 Radix

We use the prefix **0x** to indicate **hexadecimal** numbers.

2.2.2 Bit/Byte ordering

All data variables in this specification are presented with the most significant bit (or byte) on the left hand side and the least significant bit (or byte) on the right hand side. Where a variable is broken down into a number of sub-strings, the left most (most significant) sub-string consists of the most significant part of the original string and so on through to the least significant.

For example if a 64-bit value X is subdivided into four 16-bit substrings P , Q , R , S we have:

$$X = 0x0123456789ABCDEF$$

we have:

$$P = 0x0123, Q = 0x4567, R = 0x89AB, S = 0xCDEF.$$

In binary this would be:

$$X = 0000000100100011010001010110011110001001101010111100110111101111$$

$$\begin{aligned} \text{with } P &= 0000000100100011 \\ Q &= 0100010101100111 \\ R &= 1000100110101011 \\ S &= 1100110111101111 \end{aligned}$$

2.2.3 Conventions

We use the assignment operator "=", as used in several programming languages. When we write

$$\langle \text{variable} \rangle = \langle \text{expression} \rangle$$

we mean that $\langle \text{variable} \rangle$ assumes the value that $\langle \text{expression} \rangle$ had before the assignment took place. For instance,

$$x = x + y + 3$$

means

$$(\text{new value of } x) \text{ becomes } (\text{old value of } x) + (\text{old value of } y) + 3.$$

2.2.4 Subfunctions

KASUMI decomposes into a number of subfunctions (FL , FO , FI) which are used in conjunction with associated sub-keys (KL , KO , KI) in a Feistel structure comprising a number of rounds (and rounds within rounds for some subfunctions). Specific instances of the function and/or keys are represented by $XX_{i,j}$ where i is the outer round number of KASUMI and j is the inner round number.

For example the function FO comprises three rounds of the function FI , so we designate the third round of FI in the fifth round of KASUMI as $FI_{5,3}$.

2.2.5 List of Symbols

=	The assignment operator.
\oplus	The bitwise exclusive-OR operation.
	The concatenation of the two operands.
$\lll n$	The left circular rotation of the operand by n bits.
ROL()	The left circular rotation of the operand by one bit.
\cap	The bitwise AND operation.
\cup	The bitwise OR operation.

2.3 List of Functions and Variables

$f_i()$	The round function for the i^{th} round of KASUMI
FI()	A subfunction within KASUMI that translates a 16-bit input to a 16-bit output using a 16-bit subkey.
FL()	A subfunction within KASUMI that translates a 32-bit input to a 32-bit output using a 32-bit subkey.
FO()	A subfunction within KASUMI that translates a 32-bit input to a 32-bit output using two 48-bit subkeys.
K	A 128-bit key.
KL_i, KO_i, KI_i	subkeys used within the i^{th} round of KASUMI .
S7[]	An S-Box translating a 7-bit input to a 7-bit output.
S9[]	An S-Box translating a 9-bit input to a 9-bit output.

3 KASUMI operation

3.1 Introduction

(See figure 1 in Annex 1)

KASUMI is a Feistel cipher with eight rounds. It operates on a 64-bit data block and uses a 128-bit key. In this section we define the basic eight-round operation. In section 4 we define in detail the make-up of the round function $f_i()$.

3.2 Encryption

KASUMI operates on a 64-bit input I using a 128-bit key K to produce a 64-bit output $OUTPUT$, as follows:

The input I is divided into two 32-bit strings L_0 and R_0 , where

$$I = L_0 \parallel R_0$$

Then for each integer i with $1 \leq i \leq 8$ we define:

$$R_i = L_{i-1}, \quad L_i = R_{i-1} \oplus f_i(L_{i-1}, RK_i)$$

This constitutes the i^{th} round function of **KASUMI**, where f_i denotes the round function with L_{i-1} and round key RK_i as inputs (see section 4 below).

The result $OUTPUT$ is equal to the 64-bit string $(L_8 \parallel R_8)$ offered at the end of the eighth round. See figure 1 of Annex 1.

In the specifications for the f_8 and f_9 functions we represent this transformation by the term:

$$OUTPUT = KASUMI[I]_K$$

4 Components of KASUMI

4.1 Function f_i

(See figure 1 in Annex 1)

The function $f_i()$ takes a 32-bit input I and returns a 32-bit output O under the control of a round key RK_i , where the round key comprises the subkey triplet of (KL_i, KO_i, KI_i) . The function itself is constructed from two subfunctions; FL and FO with associated subkeys KL_i (used with FL) and subkeys KO_i and KI_i (used with FO).

The $f_i()$ function has two different forms depending on whether it is an even round or an odd round.

For rounds 1,3,5 and 7 we define:

$$f_i(I, RK_i) = FO(FL(I, KL_i), KO_i, KI_i)$$

and for rounds 2,4,6 and 8 we define:

$$f_i(I, RK_i) = FL(FO(I, KO_i, KI_i), KL_i)$$

i.e. For odd rounds the round data is passed through $FL()$ and then $FO()$, whilst for even rounds it is passed through $FO()$ and then $FL()$.

4.2 Function FL

(See figure 4 in Annex 1)

The input to the function FL comprises a 32-bit data input I and a 32-bit subkey KL_i . The subkey is split into two 16-bit subkeys, $KL_{i,1}$ and $KL_{i,2}$ where

$$KL_i = KL_{i,1} \parallel KL_{i,2}$$

The input data I is split into two 16-bit halves, L and R where $I = L \parallel R$.

We define:

$$\begin{aligned} R' &= R \oplus \text{ROL}(L \cap KL_{i,1}) \\ L' &= L \oplus \text{ROL}(R' \cap KL_{i,2}) \end{aligned}$$

The 32-bit output value is $(L' \parallel R')$.

4.3 Function FO

(See figure 2 in Annex 1)

The input to the function FO comprises a 32-bit data input I and two sets of subkeys, a 48-bit subkey KO_i and 48-bit subkey KI_i .

The 32-bit data input is split into two halves, L_0 and R_0 where $I = L_0 \parallel R_0$.

The 48-bit subkeys are subdivided into three 16-bit subkeys where

$$KO_i = KO_{i,1} \parallel KO_{i,2} \parallel KO_{i,3} \text{ and } KI_i = KI_{i,1} \parallel KI_{i,2} \parallel KI_{i,3}.$$

Then for each integer j with $1 \leq j \leq 3$ we define:

$$\begin{aligned} R_j &= FI(L_{j-1} \oplus KO_{i,j}, KI_{i,j}) \oplus R_{j-1} \\ L_j &= R_{j-1} \end{aligned}$$

Finally we return the 32-bit value ($L_3 \parallel R_3$).

4.4 Function FI

(See figure 3 in Annex 1. The thick and thin lines in this diagram are used to emphasise the difference between the 9-bit and 7-bit data paths respectively).

The function FI takes a 16-bit data input I and 16-bit subkey $KI_{i,j}$. The input I is split into two unequal components, a 9-bit left half L_0 and a 7-bit right half R_0 where $I = L_0 \parallel R_0$.

Similarly the key $KI_{i,j}$ is split into a 7-bit component $KI_{i,j,1}$ and a 9-bit component $KI_{i,j,2}$ where $KI_{i,j} = KI_{i,j,1} \parallel KI_{i,j,2}$.

The function uses two S-boxes, $S7$ which maps a 7-bit input to a 7-bit output, and $S9$ which maps a 9-bit input to a 9-bit output. These are fully defined in section 4.5. It also uses two additional functions which we designate $ZE()$ and $TR()$. We define these as:

$ZE(x)$ takes the 7-bit value x and converts it to a 9-bit value by adding two zero bits to the most-significant end.

$TR(x)$ takes the 9-bit value x and converts it to a 7-bit value by discarding the two most-significant bits.

We define the following series of operations:

$$\begin{aligned} L_1 &= R_0 & R_1 &= S9[L_0] \oplus ZE(R_0) \\ L_2 &= R_1 \oplus KI_{i,j,2} & R_2 &= S7[L_1] \oplus TR(R_1) \oplus KI_{i,j,1} \\ L_3 &= R_2 & R_3 &= S9[L_2] \oplus ZE(R_2) \\ L_4 &= S7[L_3] \oplus TR(R_3) & R_4 &= R_3 \end{aligned}$$

The function returns the 16-bit value ($L_4 \parallel R_4$).

4.5 S-boxes

The two S-boxes have been designed so that they may be easily implemented in combinational logic as well as by a look-up table. Both forms are given for each table.

The input x comprises either seven or nine bits with a corresponding number of bits in the output y . We therefore have:

$$x = x8 \parallel x7 \parallel x6 \parallel x5 \parallel x4 \parallel x3 \parallel x2 \parallel x1 \parallel x0$$

and

$$y = y8 \parallel y7 \parallel y6 \parallel y5 \parallel y4 \parallel y3 \parallel y2 \parallel y1 \parallel y0$$

where the $x8$, $y8$ and $x7$, $y7$ bits only apply to **S9**, and the $x0$ and $y0$ bits are the least significant bits.

In the logic equations:

$x0x1x2$ implies $x0 \cap x1 \cap x2$ where \cap is the **AND** operator.

\oplus is the exclusive-OR operator.

Following the presentation of the logic equations and the equivalent look-up table an example is given of the use of each.

4.5.1 S7

Gate Logic :

$$y0 = x1x3 \oplus x4 \oplus x0x1x4 \oplus x5 \oplus x2x5 \oplus x3x4x5 \oplus x6 \oplus x0x6 \oplus x1x6 \oplus x3x6 \oplus x2x4x6 \oplus x1x5x6 \oplus x4x5x6$$

$$y1 = x0 \oplus x1 \oplus x0x4 \oplus x2x4 \oplus x5 \oplus x1x2x5 \oplus x0x3x5 \oplus x6 \oplus x0x2x6 \oplus x3x6 \oplus x4x5x6 \oplus 1$$

$$y2 = x0 \oplus x0x3 \oplus x2x3 \oplus x1x2x4 \oplus x0x3x4 \oplus x1x5 \oplus x0x2x5 \oplus x0x6 \oplus x0x1x6 \oplus x2x6 \oplus x4x6 \oplus 1$$

$$y3 = x1 \oplus x0x1x2 \oplus x1x4 \oplus x3x4 \oplus x0x5 \oplus x0x1x5 \oplus x2x3x5 \oplus x1x4x5 \oplus x2x6 \oplus x1x3x6$$

$$y4 = x0x2 \oplus x3 \oplus x1x3 \oplus x1x4 \oplus x0x1x4 \oplus x2x3x4 \oplus x0x5 \oplus x1x3x5 \oplus x0x4x5 \oplus x1x6 \oplus x3x6 \oplus x0x3x6 \oplus x5x6 \oplus 1$$

$$y5 = x2 \oplus x0x2 \oplus x0x3 \oplus x1x2x3 \oplus x0x2x4 \oplus x0x5 \oplus x2x5 \oplus x4x5 \oplus x1x6 \oplus x1x2x6 \oplus x0x3x6 \oplus x3x4x6 \oplus x2x5x6 \oplus 1$$

$$y6 = x1x2 \oplus x0x1x3 \oplus x0x4 \oplus x1x5 \oplus x3x5 \oplus x6 \oplus x0x1x6 \oplus x2x3x6 \oplus x1x4x6 \oplus x0x5x6$$

Decimal Table :

54,	50,	62,	56,	22,	34,	94,	96,	38,	6,	63,	93,	2,	18,123,	33,
55,113,	39,114,	21,	67,	65,	12,	47,	73,	46,	27,	25,111,124,	81,			
53,	9,121,	79,	52,	60,	58,	48,101,127,	40,120,104,	70,	71,	43,				
20,122,	72,	61,	23,109,	13,100,	77,	1,	16,	7,	82,	10,105,	98,			
117,116,	76,	11,	89,106,	0,125,118,	99,	86,	69,	30,	57,126,	87,				
112,	51,	17,	5,	95,	14,	90,	84,	91,	8,	35,103,	32,	97,	28,	66,
102,	31,	26,	45,	75,	4,	85,	92,	37,	74,	80,	49,	68,	29,115,	44,
64,107,108,	24,110,	83,	36,	78,	42,	19,	15,	41,	88,119,	59,	3			

Example:

If we have an input value = 38, then using the decimal table S7[38] = 58.

For the combinational logic we have:

$$38 = 0100110_2 \Rightarrow x6 = 0, x5=1, x4=0, x3=0, x2=1, x1=1, x0=0$$

which gives us:

$$\begin{aligned}
 y_0 &= 0 \oplus 0 \oplus 0 \oplus 1 \oplus 1 \oplus 0 \oplus 0 \oplus 0 \oplus 0 \oplus 0 \oplus 0 \oplus 0 \oplus 0 &= 0 \\
 y_1 &= 0 \oplus 0 \oplus 0 \oplus 1 \oplus 1 \oplus 0 \oplus 0 \oplus 0 \oplus 0 \oplus 0 \oplus 1 &= 1 \\
 y_2 &= 0 \oplus 0 \oplus 0 \oplus 0 \oplus 0 \oplus 1 \oplus 0 \oplus 0 \oplus 0 \oplus 0 \oplus 0 \oplus 1 &= 0 \\
 y_3 &= 1 \oplus 0 \oplus 0 \oplus 0 \oplus 0 \oplus 0 \oplus 0 \oplus 0 \oplus 0 \oplus 0 \oplus 0 &= 1 \\
 y_4 &= 0 \oplus 0 \oplus 0 \oplus 0 \oplus 0 \oplus 0 \oplus 0 \oplus 0 \oplus 0 \oplus 0 \oplus 0 \oplus 0 \oplus 1 &= 1 \\
 y_5 &= 1 \oplus 0 \oplus 0 \oplus 0 \oplus 0 \oplus 0 \oplus 1 \oplus 0 \oplus 0 \oplus 0 \oplus 0 \oplus 0 \oplus 0 \oplus 1 &= 1 \\
 y_6 &= 1 \oplus 0 \oplus 0 \oplus 1 \oplus 0 \oplus 0 \oplus 0 \oplus 0 \oplus 0 \oplus 0 \oplus 0 &= 0
 \end{aligned}$$

Thus $y = 0111010_2 = 58$

4.5.2 S9

Gate Logic :

$$\begin{aligned}
 y_0 &= x_0x_2x_3x_2x_5x_6x_0x_7x_1x_7x_2x_7x_4x_8x_5x_8x_7x_8x_1 \\
 y_1 &= x_1x_0x_1x_2x_3x_0x_4x_1x_4x_0x_5x_3x_5x_6x_1x_7x_2x_7x_5x_8x_1 \\
 y_2 &= x_1x_0x_3x_3x_4x_0x_5x_2x_6x_3x_6x_5x_6x_4x_7x_5x_7x_6x_7x_8x_0x_8x_1 \\
 y_3 &= x_0x_1x_2x_0x_3x_2x_4x_5x_0x_6x_1x_6x_4x_7x_0x_8x_1x_8x_7x_8 \\
 y_4 &= x_0x_1x_1x_3x_4x_0x_5x_3x_6x_0x_7x_6x_7x_1x_8x_2x_8x_3x_8 \\
 y_5 &= x_2x_1x_4x_4x_5x_0x_6x_1x_6x_3x_7x_4x_7x_6x_7x_5x_8x_6x_8x_7x_8x_1 \\
 y_6 &= x_0x_2x_3x_1x_5x_2x_5x_4x_5x_3x_6x_4x_6x_5x_6x_7x_1x_8x_3x_8x_5x_8x_7x_8 \\
 y_7 &= x_0x_1x_0x_2x_1x_2x_3x_0x_3x_2x_3x_4x_5x_2x_6x_3x_6x_2x_7x_5x_7x_8x_1 \\
 y_8 &= x_0x_1x_2x_1x_2x_3x_4x_1x_5x_2x_5x_1x_6x_4x_6x_7x_2x_8x_3x_8
 \end{aligned}$$

Decimal Table :

167,239,161,379,391,334,	9,338,38,226,48,358,452,385,90,397,
183,253,147,331,415,340,	51,362,306,500,262,82,216,159,356,177,
175,241,489,37,206,17,	0,333,44,254,378,58,143,220,81,400,
95,3,315,245,54,235,218,405,472,264,172,494,371,290,399,76,	
165,197,395,121,257,480,423,212,240,28,462,176,406,507,288,223,	
501,407,249,265,89,186,221,428,164,74,440,196,458,421,350,163,	
232,158,134,354,13,250,491,142,191,69,193,425,152,227,366,135,	
344,300,276,242,437,320,113,278,11,243,87,317,36,93,496,27,	
487,446,482,41,68,156,457,131,326,403,339,20,39,115,442,124,	
475,384,508,53,112,170,479,151,126,169,73,268,279,321,168,364,	
363,292,46,499,393,327,324,24,456,267,157,460,488,426,309,229,	
439,506,208,271,349,401,434,236,16,209,359,52,56,120,199,277,	
465,416,252,287,246,6,83,305,420,345,153,502,65,61,244,282,	
173,222,418,67,386,368,261,101,476,291,195,430,49,79,166,330,	
280,383,373,128,382,408,155,495,367,388,274,107,459,417,62,454,	
132,225,203,316,234,14,301,91,503,286,424,211,347,307,140,374,	
35,103,125,427,19,214,453,146,498,314,444,230,256,329,198,285,	
50,116,78,410,10,205,510,171,231,45,139,467,29,86,505,32,	
72,26,342,150,313,490,431,238,411,325,149,473,40,119,174,355,	
185,233,389,71,448,273,372,55,110,178,322,12,469,392,369,190,	
1,109,375,137,181,88,75,308,260,484,98,272,370,275,412,111,	
336,318,4,504,492,259,304,77,337,435,21,357,303,332,483,18,	
47,85,25,497,474,289,100,269,296,478,270,106,31,104,433,84,	
414,486,394,96,99,154,511,148,413,361,409,255,162,215,302,201,	
266,351,343,144,441,365,108,298,251,34,182,509,138,210,335,133,	
311,352,328,141,396,346,123,319,450,281,429,228,443,481,92,404,	
485,422,248,297,23,213,130,466,22,217,283,70,294,360,419,127,	
312,377,7,468,194,2,117,295,463,258,224,447,247,187,80,398,	
284,353,105,390,299,471,470,184,57,200,348,63,204,188,33,451,	
97,30,310,219,94,160,129,493,64,179,263,102,189,207,114,402,	
438,477,387,122,192,42,381,5,145,118,180,449,293,323,136,380,	
43,66,60,455,341,445,202,432,8,237,15,376,436,464,59,461	

Example:

If we have an input value = 138, then using the decimal table $S9[138] = 339$.

For the combinational logic we have:

$$138 = 010001010_2 \Rightarrow x_8 = 0, x_7 = 1, x_6 = 0, x_5 = 0, x_4 = 0, x_3 = 1, x_2 = 0, x_1 = 1, x_0 = 0$$

which gives us:

$$\begin{aligned} y_0 &= 0 \oplus 1 \oplus 0 \oplus 0 \oplus 0 \oplus 1 \oplus 0 \oplus 0 \oplus 0 \oplus 0 \oplus 1 &= 1 \\ y_1 &= 1 \oplus 0 \oplus 0 \oplus 0 \oplus 0 \oplus 0 \oplus 0 \oplus 0 \oplus 1 \oplus 0 \oplus 0 \oplus 1 &= 1 \\ y_2 &= 1 \oplus 0 \oplus 0 \oplus 0 \oplus 0 \oplus 0 \oplus 0 \oplus 0 \oplus 0 \oplus 0 \oplus 0 \oplus 1 &= 0 \\ y_3 &= 0 \oplus 0 \oplus 0 \oplus 0 \oplus 0 \oplus 0 \oplus 0 \oplus 0 \oplus 0 \oplus 0 \oplus 0 &= 0 \\ y_4 &= 0 \oplus 1 \oplus 0 \oplus 0 \oplus 0 \oplus 0 \oplus 0 \oplus 0 \oplus 0 \oplus 0 &= 1 \\ y_5 &= 0 \oplus 0 \oplus 0 \oplus 0 \oplus 0 \oplus 1 \oplus 0 \oplus 0 \oplus 0 \oplus 0 \oplus 0 \oplus 1 &= 0 \\ y_6 &= 0 \oplus 0 \oplus 0 \oplus 0 \oplus 0 \oplus 0 \oplus 0 \oplus 0 \oplus 1 \oplus 0 \oplus 0 \oplus 0 \oplus 0 &= 1 \\ y_7 &= 0 \oplus 0 \oplus 0 \oplus 1 \oplus 0 \oplus 0 \oplus 0 \oplus 0 \oplus 0 \oplus 0 \oplus 0 \oplus 0 \oplus 1 &= 0 \\ y_8 &= 0 \oplus 0 \oplus 0 \oplus 0 \oplus 0 \oplus 0 \oplus 0 \oplus 0 \oplus 1 \oplus 0 \oplus 0 &= 1 \end{aligned}$$

Thus $y = 101010011_2 = 339$

4.6 Key Schedule

KASUMI has a 128-bit key K . Each round of KASUMI uses 128 bits of key that are derived from K . Before the round keys can be calculated two 16-bit arrays K_j and K_j' ($j=1$ to 8) are derived in the following manner:

The 128-bit key K is subdivided into eight 16-bit values $K1...K8$ where

$$K = K1 \parallel K2 \parallel K3 \parallel \dots \parallel K8.$$

A second array of subkeys, K_j' is derived from K_j by applying:

For each integer j with $1 \leq j \leq 8$

$$K_j' = K_j \oplus C_j$$

Where C_j is the constant value defined in table 2.

The round subkeys are then derived from K_j and K_j' in the manner defined in table 1.

Table 1: Round subkeys

	1	2	3	4	5	6	7	8
$KL_{i,1}$	$K1 \lll 1$	$K2 \lll 1$	$K3 \lll 1$	$K4 \lll 1$	$K5 \lll 1$	$K6 \lll 1$	$K7 \lll 1$	$K8 \lll 1$
$KL_{i,2}$	$K3'$	$K4'$	$K5'$	$K6'$	$K7'$	$K8'$	$K1'$	$K2'$
$KO_{i,1}$	$K2 \lll 5$	$K3 \lll 5$	$K4 \lll 5$	$K5 \lll 5$	$K6 \lll 5$	$K7 \lll 5$	$K8 \lll 5$	$K1 \lll 5$
$KO_{i,2}$	$K6 \lll 8$	$K7 \lll 8$	$K8 \lll 8$	$K1 \lll 8$	$K2 \lll 8$	$K3 \lll 8$	$K4 \lll 8$	$K5 \lll 8$
$KO_{i,3}$	$K7 \lll 13$	$K8 \lll 13$	$K1 \lll 13$	$K2 \lll 13$	$K3 \lll 13$	$K4 \lll 13$	$K5 \lll 13$	$K6 \lll 13$
$KL_{i,1}$	$K5'$	$K6'$	$K7'$	$K8'$	$K1'$	$K2'$	$K3'$	$K4'$
$KL_{i,2}$	$K4'$	$K5'$	$K6'$	$K7'$	$K8'$	$K1'$	$K2'$	$K3'$
$KL_{i,3}$	$K8'$	$K1'$	$K2'$	$K3'$	$K4'$	$K5'$	$K6'$	$K7'$

Table 2: Constants

C1	0x0123
C2	0x4567
C3	0x89AB
C4	0xCDEF
C5	0xFEDC
C6	0xBA98
C7	0x7654
C8	0x3210

INFORMATIVE SECTION

This part of the document is purely informative and does not form part of the normative specification of KASUMI.

Annex 1 (informative): Figures of the KASUMI Algorithm

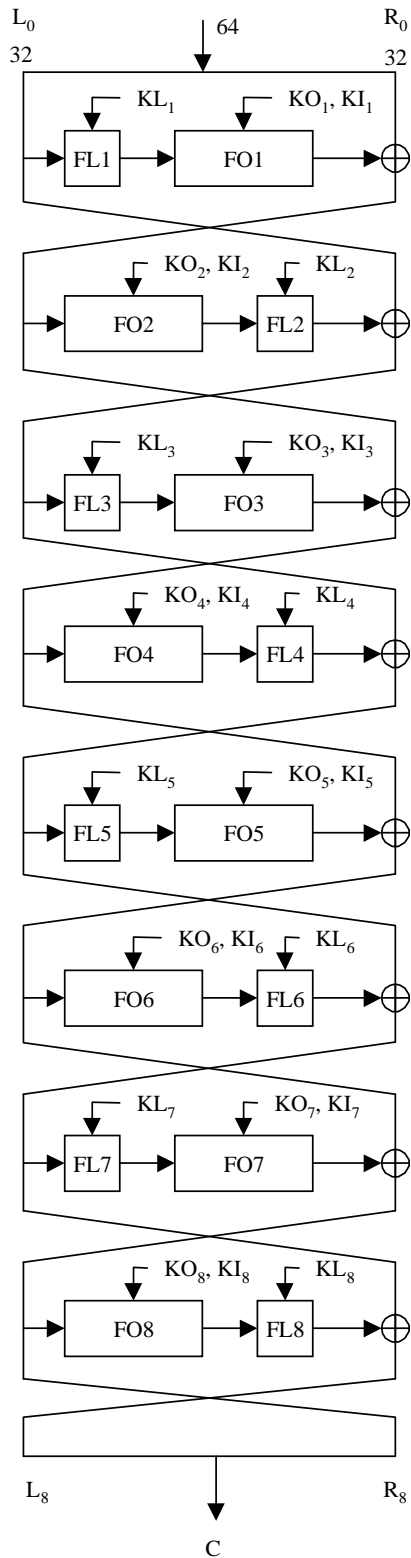

Fig. 1: KASUMI

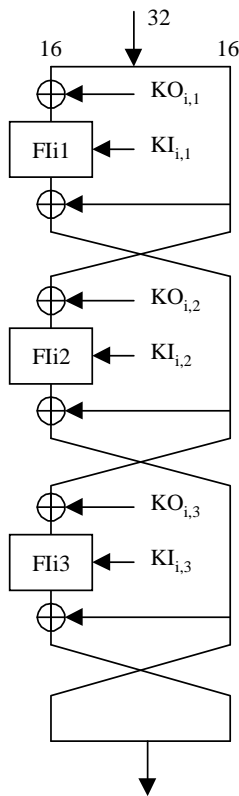

Fig.2: FO Function

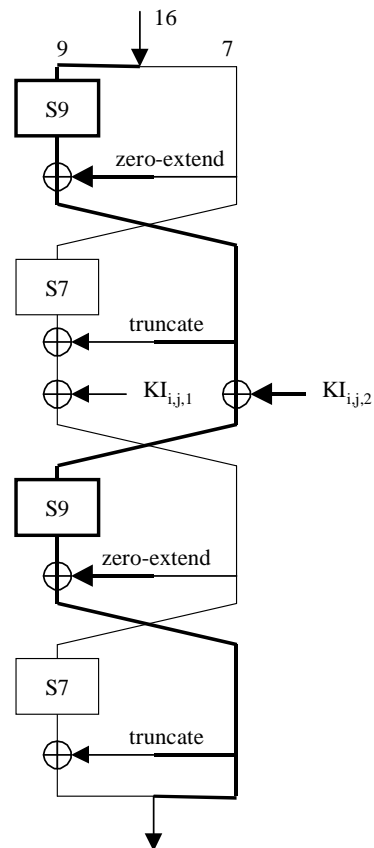

Fig.3: FI Function

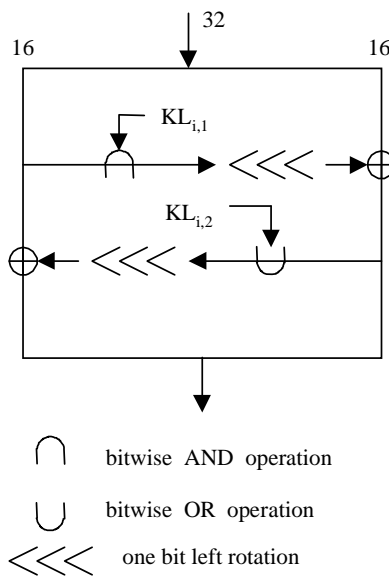

Fig.4: FL Function

- bitwise AND operation
- bitwise OR operation
- one bit left rotation

KASUMI has a number of characteristics that may be exploited in a hardware implementation and these are highlighted here.

- The simple key schedule is easy to implement in hardware.
- The S-Boxes have been designed so that they may be implemented by a small amount of combinational logic rather than by large look-up tables.
- The S7-Box and S9-Box operations in the FI function may be carried out in parallel (see alternative presentation in figure 5).
- The $FI_{i,1}$ and $FI_{i,2}$ operations may be carried out in parallel (see alternative presentation in figure 6).

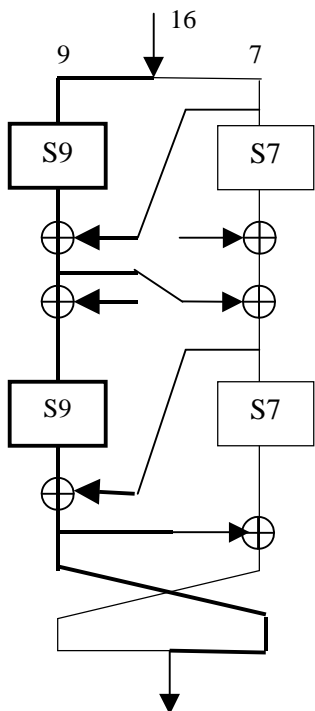

Fig.5: FI Function

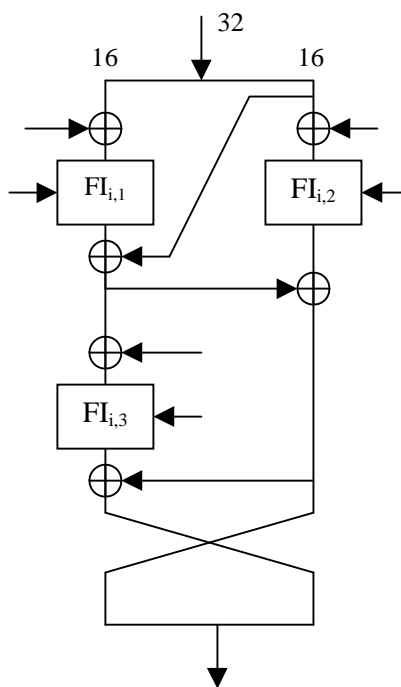

Fig.6: FO Function

Annex 2 (informative): Simulation Program Listing

Header file

```

/*-----
 *           Kasumi.h
 *-----*/

typedef unsigned char  u8;
typedef unsigned short u16;
typedef unsigned long  u32;

void KeySchedule( u8 *key );
void Kasumi( u8 *data );

```

C Code

```

/*-----
 *           Kasumi.c
 *-----
 *
 * A sample implementation of KASUMI, the core algorithm for the
 * 3GPP Confidentiality and Integrity algorithms.
 *
 * This has been coded for clarity, not necessarily for efficiency.
 *
 * This will compile and run correctly on both Intel (little endian)
 * and Sparc (big endian) machines. (Compilers used supported 32-bit ints).
 *
 * Version 1.1      08 May 2000
 *-----*/

#include "Kasumi.h"

/*----- 16 bit rotate left -----*/
#define ROL16(a,b) (u16)((a<<b)|(a>>(16-b)))

/*----- unions: used to remove "endian" issues -----*/
typedef union {
    u32 b32;
    u16 b16[2];
    u8  b8[4];
} DWORD;

typedef union {
    u16 b16;
    u8  b8[2];
} WORD;

/*----- globals: The subkey arrays -----*/

static u16 KLi1[8], KLi2[8];
static u16 KOi1[8], KOi2[8], KOi3[8];
static u16 KIi1[8], KIi2[8], KIi3[8];

/*-----
 * FI()
 * The FI function (fig 3). It includes the S7 and S9 tables.
 * Transforms a 16-bit value.
 *-----*/
static u16 FI( u16 in, u16 subkey )
{
    u16 nine, seven;
    static u16 S7[] = {
        54, 50, 62, 56, 22, 34, 94, 96, 38, 6, 63, 93, 2, 18,123, 33,
        55,113, 39,114, 21, 67, 65, 12, 47, 73, 46, 27, 25,111,124, 81,
        53, 9,121, 79, 52, 60, 58, 48,101,127, 40,120,104, 70, 71, 43,
        20,122, 72, 61, 23,109, 13,100, 77, 1, 16, 7, 82, 10,105, 98,

```

```

117,116, 76, 11, 89,106, 0,125,118, 99, 86, 69, 30, 57,126, 87,
112, 51, 17, 5, 95, 14, 90, 84, 91, 8, 35,103, 32, 97, 28, 66,
102, 31, 26, 45, 75, 4, 85, 92, 37, 74, 80, 49, 68, 29,115, 44,
64,107,108, 24,110, 83, 36, 78, 42, 19, 15, 41, 88,119, 59, 3};
static u16 S9[] = {
167,239,161,379,391,334, 9,338, 38,226, 48,358,452,385, 90,397,
183,253,147,331,415,340, 51,362,306,500,262, 82,216,159,356,177,
175,241,489, 37,206, 17, 0,333, 44,254,378, 58,143,220, 81,400,
95, 3,315,245, 54,235,218,405,472,264,172,494,371,290,399, 76,
165,197,395,121,257,480,423,212,240, 28,462,176,406,507,288,223,
501,407,249,265, 89,186,221,428,164, 74,440,196,458,421,350,163,
232,158,134,354, 13,250,491,142,191, 69,193,425,152,227,366,135,
344,300,276,242,437,320,113,278, 11,243, 87,317, 36, 93,496, 27,
487,446,482, 41, 68,156,457,131,326,403,339, 20, 39,115,442,124,
475,384,508, 53,112,170,479,151,126,169, 73,268,279,321,168,364,
363,292, 46,499,393,327,324, 24,456,267,157,460,488,426,309,229,
439,506,208,271,349,401,434,236, 16,209,359, 52, 56,120,199,277,
465,416,252,287,246, 6, 83,305,420,345,153,502, 65, 61,244,282,
173,222,418, 67,386,368,261,101,476,291,195,430, 49, 79,166,330,
280,383,373,128,382,408,155,495,367,388,274,107,459,417, 62,454,
132,225,203,316,234, 14,301, 91,503,286,424,211,347,307,140,374,
35,103,125,427, 19,214,453,146,498,314,444,230,256,329,198,285,
50,116, 78,410, 10,205,510,171,231, 45,139,467, 29, 86,505, 32,
72, 26,342,150,313,490,431,238,411,325,149,473, 40,119,174,355,
185,233,389, 71,448,273,372, 55,110,178,322, 12,469,392,369,190,
1,109,375,137,181, 88, 75,308,260,484, 98,272,370,275,412,111,
336,318, 4,504,492,259,304, 77,337,435, 21,357,303,332,483, 18,
47, 85, 25,497,474,289,100,269,296,478,270,106, 31,104,433, 84,
414,486,394, 96, 99,154,511,148,413,361,409,255,162,215,302,201,
266,351,343,144,441,365,108,298,251, 34,182,509,138,210,335,133,
311,352,328,141,396,346,123,319,450,281,429,228,443,481, 92,404,
485,422,248,297, 23,213,130,466, 22,217,283, 70,294,360,419,127,
312,377, 7,468,194, 2,117,295,463,258,224,447,247,187, 80,398,
284,353,105,390,299,471,470,184, 57,200,348, 63,204,188, 33,451,
97, 30,310,219, 94,160,129,493, 64,179,263,102,189,207,114,402,
438,477,387,122,192, 42,381, 5,145,118,180,449,293,323,136,380,
43, 66, 60,455,341,445,202,432, 8,237, 15,376,436,464, 59,461};

/* The sixteen bit input is split into two unequal halves, *
 * nine bits and seven bits - as is the subkey */

nine = (u16)(in>>7);
seven = (u16)(in&0x7F);

/* Now run the various operations */

nine = (u16)(S9[nine] ^ seven);
seven = (u16)(S7[seven] ^ (nine & 0x7F));

seven ^= (subkey>>9);
nine ^= (subkey&0x1FF);

nine = (u16)(S9[nine] ^ seven);
seven = (u16)(S7[seven] ^ (nine & 0x7F));

in = (u16)((seven<<9) + nine);

return( in );
}

/*-----
 * FO()
 * The FO() function.
 * Transforms a 32-bit value. Uses <index> to identify the
 * appropriate subkeys to use.
 *-----*/
static u32 FO( u32 in, int index )
{
    u16 left, right;

    /* Split the input into two 16-bit words */

    left = (u16)(in>>16);
    right = (u16) in;

    /* Now apply the same basic transformation three times */

```

```

    left ^= KOi1[index];
    left = FI( left, KIi1[index] );
    left ^= right;

    right ^= KOi2[index];
    right = FI( right, KIi2[index] );
    right ^= left;

    left ^= KOi3[index];
    left = FI( left, KIi3[index] );
    left ^= right;

    in = (((u32)right)<<16)+left;

    return( in );
}

/*-----
 * FL()
 * The FL() function.
 * Transforms a 32-bit value. Uses <index> to identify the
 * appropriate subkeys to use.
 *-----*/
static u32 FL( u32 in, int index )
{
    u16 l, r, a, b;

    /* split out the left and right halves */

    l = (u16)(in>>16);
    r = (u16)(in);

    /* do the FL() operations */

    a = (u16)(l & KLi1[index]);
    r ^= ROL16(a,1);

    b = (u16)(r | KLi2[index]);
    l ^= ROL16(b,1);

    /* put the two halves back together */

    in = (((u32)l)<<16) + r;

    return( in );
}

/*-----
 * Kasumi()
 * the Main algorithm (fig 1). Apply the same pair of operations
 * four times. Transforms the 64-bit input.
 *-----*/
void Kasumi( u8 *data )
{
    u32 left, right, temp;
    DWORD *d;
    int n;

    /* Start by getting the data into two 32-bit words (endian correct) */

    d = (DWORD*)data;
    left = (((u32)d[0].b8[0])<<24)+(((u32)d[0].b8[1])<<16)
+ (d[0].b8[2]<<8)+d[0].b8[3];
    right = (((u32)d[1].b8[0])<<24)+(((u32)d[1].b8[1])<<16)
+ (d[1].b8[2]<<8)+d[1].b8[3];
    n = 0;
    do{
        temp = FL( left, n );
        temp = FO( temp, n++ );
        right ^= temp;
        temp = FO( right, n );
        temp = FL( temp, n++ );
        left ^= temp;
    }while( n<=7 );

    /* return the correct endian result */
    d[0].b8[0] = (u8)(left>>24);    d[1].b8[0] = (u8)(right>>24);
    d[0].b8[1] = (u8)(left>>16);    d[1].b8[1] = (u8)(right>>16);
}

```

```

    d[0].b8[2] = (u8)(left>>8);    d[1].b8[2] = (u8)(right>>8);
    d[0].b8[3] = (u8)(left);       d[1].b8[3] = (u8)(right);
}

/*-----
 * KeySchedule()
 *   Build the key schedule. Most "key" operations use 16-bit
 *   subkeys so we build u16-sized arrays that are "endian" correct.
 *-----*/
void KeySchedule( u8 *k )
{
    static u16 C[] = {
        0x0123,0x4567,0x89AB,0xCDEF, 0xFEDC,0xBA98,0x7654,0x3210 };
    u16 key[8], Kprime[8];
    WORD *k16;
    int n;

    /* Start by ensuring the subkeys are endian correct on a 16-bit basis */

    k16 = (WORD *)k;
    for( n=0; n<8; ++n )
        key[n] = (u16)((k16[n].b8[0]<<8) + (k16[n].b8[1]));

    /* Now build the K'[] keys */

    for( n=0; n<8; ++n )
        Kprime[n] = (u16)(key[n] ^ C[n]);

    /* Finally construct the various sub keys */

    for( n=0; n<8; ++n )
    {
        KLi1[n] = ROL16(key[n],1);
        KLi2[n] = Kprime[(n+2)&0x7];
        KOi1[n] = ROL16(key[(n+1)&0x7],5);
        KOi2[n] = ROL16(key[(n+5)&0x7],8);
        KOi3[n] = ROL16(key[(n+6)&0x7],13);
        KIi1[n] = Kprime[(n+4)&0x7];
        KIi2[n] = Kprime[(n+3)&0x7];
        KIi3[n] = Kprime[(n+7)&0x7];
    }
}

/*-----
 *           e n d   o f   k a s u m i . c
 *-----*/

```

Annex 3 (informative): Change history

Change history							
Date	TSG #	TSG Doc.	CR	Rev	Subject/Comment	Old	New
12-1999	-	-	-	-	ETSI SAGE Publication (restricted)	-	SAGE v1.0
05-2000	-	-	-	-	ETSI SAGE update: Small change to sample code (portability issue)	SAGE v1.0	SAGE v1.1
09-2000	SA_07				Approved by TSG SA and placed under change control	SAGE v1.1	3.1.0
07-2001	-	-	-	-	Word version received: Re-formatted into 3GPP TS format (MCC) No technical change from version 3.1.0.	3.1.0	3.1.1
08-2001	-				Addition of Mitsubishi IPR information in Foreword and correction of reference titles. No technical change from version 3.1.0.	3.1.1	3.1.2
08-2001	-	-	-	-	Release 4 version created.	3.1.2	4.0.0
06-2002	-	-	-	-	Release 5 version created.	4.0.0	5.0.0
12-2004	SP-26	-	-	-	Release 6 version created.	5.0.0	6.0.0
2005-09	SP-29	SP-050564	0001	-	Kasumi roundfunction, correction of formula	6.0.0	6.1.0
06-2007	SP-36	-	-	-	Release 7 version created.	6.1.0	7.0.0
12-2008	SP-32	-	-	-	Release 8 version created.	7.0.0	8.0.0
2009-12	-	-	-	-	Rel-9 version created	8.0.0	9.0.0
2011-03	-	-	-	-	Update to Rel-10 version (MCC)	9.0.0	10.0.0
2012-09	-	-	-	-	Update to Rel-11 version (MCC)	10.0.0	11.0.0
2014-09	-	-	-	-	Update to Rel-12 version (MCC)	11.0.0	12.0.0
2016-01	-	-	-	-	Update to Rel-13 version (MCC)	12.0.0	13.0.0

History

Document history		
V13.0.0	January 2016	Publication