

ETSI TS 136 101 V10.30.0 (2021-09)



**LTE;
Evolved Universal Terrestrial Radio Access (E-UTRA);
User Equipment (UE) radio transmission and reception
(3GPP TS 36.101 version 10.30.0 Release 10)**



Reference

RTS/TSGR-0436101vau0

Keywords

LTE

ETSI

650 Route des Lucioles
F-06921 Sophia Antipolis Cedex - FRANCE

Tel.: +33 4 92 94 42 00 Fax: +33 4 93 65 47 16

Siret N° 348 623 562 00017 - APE 7112B
Association à but non lucratif enregistrée à la
Sous-Préfecture de Grasse (06) N° w061004871

Important notice

The present document can be downloaded from:

<http://www.etsi.org/standards-search>

The present document may be made available in electronic versions and/or in print. The content of any electronic and/or print versions of the present document shall not be modified without the prior written authorization of ETSI. In case of any existing or perceived difference in contents between such versions and/or in print, the prevailing version of an ETSI deliverable is the one made publicly available in PDF format at www.etsi.org/deliver.

Users of the present document should be aware that the document may be subject to revision or change of status.

Information on the current status of this and other ETSI documents is available at

<https://portal.etsi.org/TB/ETSIDeliverableStatus.aspx>

If you find errors in the present document, please send your comment to one of the following services:

<https://portal.etsi.org/People/CommitteeSupportStaff.aspx>

Notice of disclaimer & limitation of liability

The information provided in the present deliverable is directed solely to professionals who have the appropriate degree of experience to understand and interpret its content in accordance with generally accepted engineering or other professional standard and applicable regulations.

No recommendation as to products and services or vendors is made or should be implied.

No representation or warranty is made that this deliverable is technically accurate or sufficient or conforms to any law and/or governmental rule and/or regulation and further, no representation or warranty is made of merchantability or fitness for any particular purpose or against infringement of intellectual property rights.

In no event shall ETSI be held liable for loss of profits or any other incidental or consequential damages.

Any software contained in this deliverable is provided "AS IS" with no warranties, express or implied, including but not limited to, the warranties of merchantability, fitness for a particular purpose and non-infringement of intellectual property rights and ETSI shall not be held liable in any event for any damages whatsoever (including, without limitation, damages for loss of profits, business interruption, loss of information, or any other pecuniary loss) arising out of or related to the use of or inability to use the software.

Copyright Notification

No part may be reproduced or utilized in any form or by any means, electronic or mechanical, including photocopying and microfilm except as authorized by written permission of ETSI.

The content of the PDF version shall not be modified without the written authorization of ETSI.

The copyright and the foregoing restriction extend to reproduction in all media.

© ETSI 2021.
All rights reserved.

Intellectual Property Rights

Essential patents

IPRs essential or potentially essential to normative deliverables may have been declared to ETSI. The declarations pertaining to these essential IPRs, if any, are publicly available for **ETSI members and non-members**, and can be found in ETSI SR 000 314: "*Intellectual Property Rights (IPRs); Essential, or potentially Essential, IPRs notified to ETSI in respect of ETSI standards*", which is available from the ETSI Secretariat. Latest updates are available on the ETSI Web server (<https://ipr.etsi.org/>).

Pursuant to the ETSI Directives including the ETSI IPR Policy, no investigation regarding the essentiality of IPRs, including IPR searches, has been carried out by ETSI. No guarantee can be given as to the existence of other IPRs not referenced in ETSI SR 000 314 (or the updates on the ETSI Web server) which are, or may be, or may become, essential to the present document.

Trademarks

The present document may include trademarks and/or tradenames which are asserted and/or registered by their owners. ETSI claims no ownership of these except for any which are indicated as being the property of ETSI, and conveys no right to use or reproduce any trademark and/or tradename. Mention of those trademarks in the present document does not constitute an endorsement by ETSI of products, services or organizations associated with those trademarks.

DECT™, **PLUGTESTS™**, **UMTS™** and the ETSI logo are trademarks of ETSI registered for the benefit of its Members. **3GPP™** and **LTE™** are trademarks of ETSI registered for the benefit of its Members and of the 3GPP Organizational Partners. **oneM2M™** logo is a trademark of ETSI registered for the benefit of its Members and of the oneM2M Partners. **GSM®** and the GSM logo are trademarks registered and owned by the GSM Association.

Legal notice

This Technical Specification (TS) has been produced by the ETSI 3rd Generation Partnership Project (3GPP).

The present document may refer to technical specifications or reports using their 3GPP identities. These shall be interpreted as being references to the corresponding ETSI deliverables.

The cross reference between 3GPP and ETSI identities can be found under <http://webapp.etsi.org/key/queryform.asp>.

Modal verbs terminology

In the present document "**shall**", "**shall not**", "**should**", "**should not**", "**may**", "**need not**", "**will**", "**will not**", "**can**" and "**cannot**" are to be interpreted as described in clause 3.2 of the [ETSI Drafting Rules](#) (Verbal forms for the expression of provisions).

"**must**" and "**must not**" are **NOT** allowed in ETSI deliverables except when used in direct citation.

Contents

Intellectual Property Rights	2
Legal notice	2
Modal verbs terminology.....	2
Foreword.....	14
1 Scope	15
2 References	15
3 Definitions, symbols and abbreviations	15
3.1 Definitions	15
3.2 Symbols.....	16
3.3 Abbreviations	18
4 General	19
4.1 Relationship between minimum requirements and test requirements	19
4.2 Applicability of minimum requirements	19
4.3 Void.....	19
4.3A Applicability of minimum requirements (CA, UL-MIMO)	19
4.4 RF requirements in later releases	20
5 Operating bands and channel arrangement.....	20
5.1 General	20
5.2 Void.....	20
5.3 Void.....	20
5.4 Void.....	20
5.5 Operating bands.....	20
5.5A Operating bands for CA	22
5.5B Operating bands for UL-MIMO	22
5.6 Channel bandwidth.....	22
5.6.1 Channel bandwidths per operating band.....	23
5.6A Channel bandwidth for CA.....	24
5.6A.1 Channel bandwidths per operating band for CA.....	26
5.6B Channel bandwidth for UL-MIMO	27
5.6B.1 Void	27
5.7 Channel arrangement.....	27
5.7.1 Channel spacing.....	27
5.7.1A Channel spacing for CA.....	27
5.7.2 Channel raster	27
5.7.2A Channel raster for CA.....	28
5.7.3 Carrier frequency and EARFCN.....	28
5.7.4 TX–RX frequency separation	29
5.7.4A TX–RX frequency separation for CA.....	30
6 Transmitter characteristics	30
6.1 General	30
6.2 Transmit power	30
6.2.1 Void	30
6.2.2 UE maximum output power.....	30
6.2.2A UE maximum output power for CA.....	31
6.2.2B UE maximum output power for UL-MIMO	32
6.2.3 UE maximum output power for modulation / channel bandwidth.....	33
6.2.3A UE Maximum Output power for modulation / channel bandwidth for CA	34
6.2.3B UE maximum output power for modulation / channel bandwidth for UL-MIMO	35
6.2.4 UE maximum output power with additional requirements	35
6.2.4A UE maximum output power with additional requirements for CA	42
6.2.4A.1 A-MPR for CA_NS_01 for CA_1C.....	43
6.2.4A.2 A-MPR for CA_NS_02 for CA_1C.....	44

6.2.4A.3	A-MPR for CA_NS_03 for CA_1C	44
6.2.4B	UE maximum output power with additional requirements for UL-MIMO	45
6.2.5	Configured transmitted power	45
6.2.5A	Configured transmitted power for CA	47
6.2.5B	Configured transmitted power for UL-MIMO	48
6.3	Output power dynamics	49
6.3.1	(Void)	49
6.3.2	Minimum output power	49
6.3.2.1	Minimum requirement	49
6.3.2A	UE Minimum output power for CA	49
6.3.2A.1	Minimum requirement for CA	49
6.3.2B	UE Minimum output power for UL-MIMO	50
6.3.2B.1	Minimum requirement	50
6.3.3	Transmit OFF power	50
6.3.3.1	Minimum requirement	50
6.3.3A	UE Transmit OFF power for CA	51
6.3.3A.1	Minimum requirement for CA	51
6.3.3B	UE Transmit OFF power for UL-MIMO	51
6.3.3B.1	Minimum requirement	51
6.3.4	ON/OFF time mask	51
6.3.4.1	General ON/OFF time mask	51
6.3.4.2	PRACH and SRS time mask	52
6.3.4.2.1	PRACH time mask	52
6.3.4.2.2	SRS time mask	52
6.3.4.3	Slot / Sub frame boundary time mask	53
6.3.4.4	PUCCH / PUSCH / SRS time mask	54
6.3.4A	ON/OFF time mask for CA	55
6.3.4B	ON/OFF time mask for UL-MIMO	55
6.3.5	Power Control	55
6.3.5.1	Absolute power tolerance	55
6.3.5.1.1	Minimum requirements	56
6.3.5.2	Relative Power tolerance	56
6.3.5.2.1	Minimum requirements	56
6.3.5.3	Aggregate power control tolerance	57
6.3.5.3.1	Minimum requirement	57
6.3.5A	Power control for CA	58
6.3.5A.1	Absolute power tolerance	58
6.3.5A.1.1	Minimum requirements	58
6.3.5A.2	Relative power tolerance	58
6.3.5A.2.1	Minimum requirements	58
6.3.5A.3	Aggregate power control tolerance	58
6.3.5A.3.1	Minimum requirements	59
6.3.5B	Power control for UL-MIMO	59
6.4	Void	59
6.5	Transmit signal quality	59
6.5.1	Frequency error	59
6.5.1A	Frequency error for CA	59
6.5.1B	Frequency error for UL-MIMO	59
6.5.2	Transmit modulation quality	59
6.5.2.1	Error Vector Magnitude	60
6.5.2.1.1	Minimum requirement	60
6.5.2.2	Carrier leakage	60
6.5.2.2.1	Minimum requirements	60
6.5.2.3	In-band emissions	61
6.5.2.3.1	Minimum requirements	61
6.5.2.4	EVM equalizer spectrum flatness	61
6.5.2.4.1	Minimum requirements	62
6.5.2A	Transmit modulation quality for CA	63
6.5.2A.1	Error Vector Magnitude	63
6.5.2A.2	Carrier leakage for CA	63
6.5.2A.2.1	Minimum requirements	63
6.5.2A.3	In-band emissions	63

6.5.2A.3.1	Minimum requirement for CA.....	63
6.5.2B	Transmit modulation quality for UL-MIMO	65
6.5.2B.1	Error Vector Magnitude	66
6.5.2B.2	Carrier leakage	66
6.5.2B.3	In-band emissions	66
6.5.2B.4	EVM equalizer spectrum flatness for UL-MIMO	66
6.6	Output RF spectrum emissions.....	66
6.6.1	Occupied bandwidth	67
6.6.1A	Occupied bandwidth for CA	67
6.6.1B	Occupied bandwidth for UL-MIMO.....	67
6.6.2	Out of band emission	67
6.6.2.1	Spectrum emission mask	67
6.6.2.1.1	Minimum requirement.....	68
6.6.2.1A	Spectrum emission mask for CA.....	68
6.6.2.2	Additional spectrum emission mask	68
6.6.2.2.1	Minimum requirement (network signalled value "NS_03", "NS_11", and "NS_20")	68
6.6.2.2.2	Minimum requirement (network signalled value "NS_04")	69
6.6.2.2.3	Minimum requirement (network signalled value "NS_06" or "NS_07")	69
6.6.2.3	Adjacent Channel Leakage Ratio	70
6.6.2.3.1	Minimum requirement E-UTRA	70
6.6.2.3.1A	Void	71
6.6.2.3.2	Minimum requirements UTRA	71
6.6.2.3.2A	Minimum requirement UTRA for CA	72
6.6.2.3.3A	Minimum requirements for CA E-UTRA.....	72
6.6.2.4	Void.....	73
6.6.2.4.1	Void	73
6.6.2A	Void	73
6.6.2B	Out of band emission for UL-MIMO.....	73
6.6.3	Spurious emissions	73
6.6.3.1	Minimum requirements	73
6.6.3.1A	Minimum requirements for CA.....	74
6.6.3.2	Spurious emission band UE co-existence	74
6.6.3.2A	Spurious emission band UE co-existence for CA	77
6.6.3.3	Additional spurious emissions	78
6.6.3.3.1	Minimum requirement (network signalled value "NS_05")	78
6.6.3.3.2	Minimum requirement (network signalled value "NS_07")	79
6.6.3.3.3	Minimum requirement (network signalled value "NS_08")	79
6.6.3.3.4	Minimum requirement (network signalled value "NS_09")	80
6.6.3.3.5	Void	80
6.6.3.3.6	Void	80
6.6.3.3.7	Void	80
6.6.3.3.8	Void	80
6.6.3.3.9	Void	80
6.6.3.3.10	Void	80
6.6.3.3.11	Void	80
6.6.3.3.12	Void	80
6.6.3.3.13	Minimum requirement (network signalled value " NS_11")	80
6.6.3.3.14	Minimum requirement (network signalled value " NS_20")	80
6.6.3.3.15	Minimum requirement (network signalled value "NS_22")	81
6.6.3.3.16	Minimum requirement (network signalled value "NS_23")	81
6.6.3.3.17	Void	82
6.6.3.3.18	Void	82
6.6.3.3.19	Void	82
6.6.3.3.20	Void	83
6.6.3.3.21	Void	83
6.6.3.3.22	Void	83
6.6.3.3.23	Void	83
6.6.3.3.24	Void	83
6.6.3.3.25	Void	83
6.6.3.3.26	Void	83
6.6.3.3.27	Void	83
6.6.3.3.28	Void	83

6.6.3.3.29	Void	83
6.6.3.3.30	Void	84
6.6.3.3.31	Void	84
6.6.3.3.32	Void	84
6.6.3.3.33	Void	84
6.6.3.3.34	Void	84
6.6.3.3.35	Minimum requirement (network signalled value "NS_56")	84
6.6.3.3A	Additional spurious emissions for CA	84
6.6.3.3A.1	Minimum requirement for CA_1C (network signalled value "CA_NS_01")	85
6.6.3.3A.2	Minimum requirement for CA_1C (network signalled value "CA_NS_02")	85
6.6.3.3A.3	Minimum requirement for CA_1C (network signalled value "CA_NS_03")	85
6.6.3A	Void	85
6.6.3B	Spurious emission for UL-MIMO	86
6.6A	Void	86
6.6B	Void	86
6.7	Transmit intermodulation	86
6.7.1	Minimum requirement	86
6.7.1A	Minimum requirement for CA	86
6.7.1B	Minimum requirement for UL-MIMO	87
6.8	Void	87
6.8.1	Void	87
6.8A	Void	87
6.8B	Time alignment error for UL-MIMO	87
6.8B.1	Minimum Requirements	87
7	Receiver characteristics	87
7.1	General	87
7.2	Diversity characteristics	88
7.3	Reference sensitivity power level	88
7.3.1	Minimum requirements (QPSK)	88
7.3.1A	Minimum requirements (QPSK) for CA	92
7.3.1B	Minimum requirements (QPSK) for UL-MIMO	93
7.3.2	Void	93
7.4	Maximum input level	93
7.4.1	Minimum requirements	93
7.4.1A	Minimum requirements for CA	93
7.4.1B	Minimum requirements for UL-MIMO	94
7.4A	Void	94
7.4A.1	Void	94
7.5	Adjacent Channel Selectivity (ACS)	94
7.5.1	Minimum requirements	94
7.5.1A	Minimum requirements for CA	95
7.5.1B	Minimum requirements for UL-MIMO	96
7.6	Blocking characteristics	96
7.6.1	In-band blocking	97
7.6.1.1	Minimum requirements	97
7.6.1.1A	Minimum requirements for CA	97
7.6.2	Out-of-band blocking	98
7.6.2.1	Minimum requirements	99
7.6.2.1A	Minimum requirements for CA	99
7.6.3	Narrow band blocking	101
7.6.3.1	Minimum requirements	101
7.6.3.1A	Minimum requirements for CA	101
7.6A	Void	102
7.6B	Blocking characteristics for UL-MIMO	102
7.7	Spurious response	102
7.7.1	Minimum requirements	102
7.7.1A	Minimum requirements for CA	103
7.7.1B	Minimum requirements for UL-MIMO	103
7.8	Intermodulation characteristics	103
7.8.1	Wide band intermodulation	104
7.8.1.1	Minimum requirements	104

7.8.1A	Minimum requirements for CA	104
7.8.1B	Minimum requirements for UL-MIMO	105
7.8.2	Void	105
7.9	Spurious emissions	105
7.9.1	Minimum requirements	106
7.10	Receiver image	106
7.10.1	Void	106
7.10.1A	Minimum requirements for CA	106
8	Performance requirement	107
8.1	General	107
8.1.1	Dual-antenna receiver capability	107
8.1.1.1	Simultaneous unicast and MBMS operations.....	107
8.1.1.2	Dual-antenna receiver capability in idle mode	107
8.1.2	Applicability of requirements	107
8.1.2.1	Applicability of requirements for different channel bandwidths.....	107
8.1.2.2	Definition of CA capability	107
8.1.2.3	Applicability and test rules for different CA configurations and bandwidth combination sets.....	108
8.1.2.4	Test coverage for different number of component carriers	109
8.2	Demodulation of PDSCH (Cell-Specific Reference Symbols)	110
8.2.1	FDD (Fixed Reference Channel)	110
8.2.1.1	Single-antenna port performance	110
8.2.1.1.1	Minimum Requirement	110
8.2.1.1.2	Void	113
8.2.1.1.3	Void	113
8.2.1.1.4	Minimum Requirement 1 PRB allocation in presence of MBSFN.....	113
8.2.1.2	Transmit diversity performance	114
8.2.1.2.1	Minimum Requirement 2 Tx Antenna Port	114
8.2.1.2.2	Minimum Requirement 4 Tx Antenna Port	114
8.2.1.2.3	Minimum Requirement 2 Tx Antenna Ports (demodulation subframe overlaps with aggressor cell ABS).....	115
8.2.1.3	Open-loop spatial multiplexing performance.....	117
8.2.1.3.1	Minimum Requirement 2 Tx Antenna Port	117
8.2.1.3.1A	Soft buffer management test.....	118
8.2.1.3.2	Minimum Requirement 4 Tx Antenna Port	119
8.2.1.3.3	Minimum Requirement 2 Tx Antenna Port (demodulation subframe overlaps with aggressor cell ABS)	119
8.2.1.4	Closed-loop spatial multiplexing performance	123
8.2.1.4.1	Minimum Requirement Single-Layer Spatial Multiplexing 2 Tx Antenna Port.....	123
8.2.1.4.1A	Minimum Requirement Single-Layer Spatial Multiplexing 4 Tx Antenna Port.....	124
8.2.1.4.2	Minimum Requirement Multi-Layer Spatial Multiplexing 2 Tx Antenna Port	124
8.2.1.4.3	Minimum Requirement Multi-Layer Spatial Multiplexing 4 Tx Antenna Port	125
8.2.1.5	MU-MIMO.....	127
8.2.1.6	[Control channel performance: D-BCH and PCH]	127
8.2.1.7	Carrier aggregation with power imbalance	127
8.2.1.7.1	Minimum Requirement	127
8.2.2	TDD (Fixed Reference Channel)	128
8.2.2.1	Single-antenna port performance	129
8.2.2.1.1	Minimum Requirement	129
8.2.2.1.2	Void	131
8.2.2.1.3	Void	131
8.2.2.1.4	Minimum Requirement 1 PRB allocation in presence of MBSFN.....	131
8.2.2.2	Transmit diversity performance	132
8.2.2.2.1	Minimum Requirement 2 Tx Antenna Port	132
8.2.2.2.2	Minimum Requirement 4 Tx Antenna Port	133
8.2.2.2.3	Minimum Requirement 2 Tx Antenna Port (demodulation subframe overlaps with aggressor cell ABS)	133
8.2.2.3	Open-loop spatial multiplexing performance.....	135
8.2.2.3.1	Minimum Requirement 2 Tx Antenna Port	135
8.2.2.3.1A	Soft buffer management test.....	136
8.2.2.3.2	Minimum Requirement 4 Tx Antenna Port	137

8.2.2.3.3	Minimum Requirement 2Tx antenna port (demodulation subframe overlaps with aggressor cell ABS)	137
8.2.2.4Closed-loop spatial multiplexing performance	141
8.2.2.4.1	Minimum Requirement Single-Layer Spatial Multiplexing 2 Tx Antenna Port	141
8.2.2.4.1A	Minimum Requirement Single-Layer Spatial Multiplexing 4 Tx Antenna Port	142
8.2.2.4.2	Minimum Requirement Multi-Layer Spatial Multiplexing 2 Tx Antenna Port	142
8.2.2.4.3	Minimum Requirement Multi-Layer Spatial Multiplexing 4 Tx Antenna Port	143
8.2.2.5	MU-MIMO.....	145
8.2.2.6	[Control channel performance: D-BCH and PCH]	145
8.2.2.7	Carrier aggregation with power imbalance	145
8.2.2.7.1	Minimum Requirement	145
8.3	Demodulation of PDSCH (User-Specific Reference Symbols).....	146
8.3.1	FDD	146
8.3.1.1	Single-layer Spatial Multiplexing	147
8.3.1.2	Dual-Layer Spatial Multiplexing	149
8.3.2	TDD.....	150
8.3.2.1	Single-layer Spatial Multiplexing	150
8.3.2.1A	Single-layer Spatial Multiplexing (with multiple CSI-RS configurations)	153
8.3.2.2	Dual-Layer Spatial Multiplexing	154
8.3.2.3	Dual-Layer Spatial Multiplexing (with multiple CSI-RS configurations)	155
8.4	Demodulation of PDCCH/PCFICH	156
8.4.1	FDD	156
8.4.1.1	Single-antenna port performance	156
8.4.1.2	Transmit diversity performance	157
8.4.1.2.1	Minimum Requirement 2 Tx Antenna Port	157
8.4.1.2.2	Minimum Requirement 4 Tx Antenna Port	157
8.4.1.2.3	Minimum Requirement 2 Tx Antenna Port (demodulation subframe overlaps with aggressor cell ABS)	157
8.4.2	TDD.....	161
8.4.2.1	Single-antenna port performance	162
8.4.2.2	Transmit diversity performance	162
8.4.2.2.1	Minimum Requirement 2 Tx Antenna Port	162
8.4.2.2.2	Minimum Requirement 4 Tx Antenna Port	163
8.4.2.2.3	Minimum Requirement 2 Tx Antenna Port (demodulation subframe overlaps with aggressor cell ABS)	163
8.5	Demodulation of PHICH.....	167
8.5.1	FDD	167
8.5.1.1	Single-antenna port performance	167
8.5.1.2	Transmit diversity performance	168
8.5.1.2.1	Minimum Requirement 2 Tx Antenna Port	168
8.5.1.2.2	Minimum Requirement 4 Tx Antenna Port	168
8.5.1.2.3	Minimum Requirement 2 Tx Antenna Port (demodulation subframe overlaps with aggressor cell ABS)	168
8.5.2	TDD.....	170
8.5.2.1	Single-antenna port performance	170
8.5.2.2	Transmit diversity performance	171
8.5.2.2.1	Minimum Requirement 2 Tx Antenna Port	171
8.5.2.2.2	Minimum Requirement 4 Tx Antenna Port	171
8.5.2.2.3	Minimum Requirement 2 Tx Antenna Port (demodulation subframe overlaps with aggressor cell ABS)	171
8.6	Demodulation of PBCH	173
8.6.1	FDD	173
8.6.1.1	Single-antenna port performance	173
8.6.1.2	Transmit diversity performance	173
8.6.1.2.1	Minimum Requirement 2 Tx Antenna Port	173
8.6.1.2.2	Minimum Requirement 4 Tx Antenna Port	174
8.6.2	TDD.....	174
8.6.2.1	Single-antenna port performance	174
8.6.2.2	Transmit diversity performance	175
8.6.2.2.1	Minimum Requirement 2 Tx Antenna Port	175
8.6.2.2.2	Minimum Requirement 4 Tx Antenna Port	175
8.7	Sustained downlink data rate provided by lower layers	175

8.7.1	FDD	175
8.7.2	TDD	177
9	Reporting of Channel State Information	179
9.1	General	179
9.1.1	Applicability of requirements	179
9.1.1.1	Applicability of requirements for different channel bandwidths.....	179
9.1.1.2	Applicability and test rules for different CA configurations and bandwidth combination sets.....	180
9.2	CQI reporting definition under AWGN conditions	180
9.2.1	Minimum requirement PUCCH 1-0 (Cell-Specific Reference Symbols)	180
9.2.1.1	FDD.....	180
9.2.1.2	TDD	181
9.2.1.3	FDD (CSI measurements in case two CSI subframe sets are configured)	182
9.2.1.4	TDD (CSI measurements in case two CSI subframe sets are configured)	184
9.2.2	Minimum requirement PUCCH 1-1 (Cell-Specific Reference Symbols)	186
9.2.2.1	FDD.....	186
9.2.2.2	TDD	187
9.2.3	Minimum requirement PUCCH 1-1 (CSI Reference Symbols).....	188
9.2.3.1	FDD.....	188
9.2.3.2	TDD	189
9.3	CQI reporting under fading conditions.....	190
9.3.1	Frequency-selective scheduling mode	190
9.3.1.1	Minimum requirement PUSCH 3-0 (Cell-Specific Reference Symbols).....	191
9.3.1.1.1	FDD	191
9.3.1.1.2	TDD.....	192
9.3.1.2	Minimum requirement PUSCH 3-1 (CSI Reference Symbol)	193
9.3.1.2.1	FDD	193
9.3.1.2.2	TDD.....	194
9.3.2	Frequency non-selective scheduling mode	196
9.3.2.1	Minimum requirement PUCCH 1-0 (Cell-Specific Reference Symbol)	196
9.3.2.1.1	FDD	196
9.3.2.1.2	TDD.....	197
9.3.2.2	Minimum requirement PUCCH 1-1 (CSI Reference Symbol).....	199
9.3.2.2.1	FDD	199
9.3.2.2.2	TDD.....	200
9.3.3	Frequency-selective interference	202
9.3.3.1	Minimum requirement PUSCH 3-0 (Cell-Specific Reference Symbol)	202
9.3.3.1.1	FDD	202
9.3.3.1.2	TDD.....	203
9.3.3.2	Void.....	204
9.3.3.2.1	Void.....	204
9.3.3.2.2	Void.....	204
9.3.4	UE-selected subband CQI.....	204
9.3.4.1	Minimum requirement PUSCH 2-0 (Cell-Specific Reference Symbols).....	204
9.3.4.1.1	FDD	204
9.3.4.1.2	TDD.....	205
9.3.4.2	Minimum requirement PUCCH 2-0 (Cell-Specific Reference Symbols)	206
9.3.4.2.1	FDD	206
9.3.4.2.2	TDD.....	208
9.4	Reporting of Precoding Matrix Indicator (PMI).....	210
9.4.1	Single PMI	210
9.4.1.1	Minimum requirement PUSCH 3-1 (Cell-Specific Reference Symbols).....	210
9.4.1.1.1	FDD	210
9.4.1.1.2	TDD.....	211
9.4.1.2	Minimum requirement PUCCH 2-1 (Cell-Specific Reference Symbols)	212
9.4.1.2.1	FDD	212
9.4.1.2.2	TDD.....	214
9.4.1.3	Minimum requirement PUSCH 3-1 (CSI Reference Symbol)	216
9.4.1.3.1	FDD	216
9.4.1.3.2	TDD.....	217
9.4.1a	Void	219
9.4.1a.1	Void.....	219

9.4.1a.1.1	Void	219
9.4.1a.1.2	Void	219
9.4.2	Multiple PMI	219
9.4.2.1	Minimum requirement PUSCH 1-2 (Cell-Specific Reference Symbols)	219
9.4.2.1.1	FDD	219
9.4.2.1.2	TDD	220
9.4.2.2	Minimum requirement PUSCH 2-2 (Cell-Specific Reference Symbols)	221
9.4.2.2.1	FDD	221
9.4.2.2.2	TDD	222
9.4.2.3	Minimum requirement PUSCH 1-2 (CSI Reference Symbol)	223
9.4.2.3.1	FDD	223
9.4.2.3.2	TDD	225
9.4.3	Void	227
9.4.3.1	Void	227
9.4.3.1.1	Void	227
9.4.3.1.2	Void	227
9.5	Reporting of Rank Indicator (RI)	227
9.5.1	Minimum requirement (Cell-Specific Reference Symbols)	227
9.5.1.1	FDD	227
9.5.1.2	TDD	229
9.5.2	Minimum requirement (CSI Reference Symbols)	230
9.5.2.1	FDD	230
9.5.2.2	TDD	232
9.5.3	Minimum requirement (CSI measurements in case two CSI subframe sets are configured)	234
9.5.3.1	FDD	234
9.5.3.2	TDD	236
9.6	Additional requirements for carrier aggregation	238
9.6.1	Periodic reporting on multiple cells (Cell-Specific Reference Symbols)	238
9.6.1.1	FDD	238
9.6.1.2	TDD	239
10	Performance requirement (MBMS)	240
10.1	FDD (Fixed Reference Channel)	240
10.1.1	Minimum requirement	241
10.2	TDD (Fixed Reference Channel)	241
10.2.1	Minimum requirement	242
Annex A (normative): Measurement channels		243
A.1	General	243
A.2	UL reference measurement channels	243
A.2.1	General	243
A.2.1.1	Applicability and common parameters	243
A.2.1.2	Determination of payload size	243
A.2.1.3	Overview of UL reference measurement channels	244
A.2.2	Reference measurement channels for FDD	248
A.2.2.1	Full RB allocation	248
A.2.2.1.1	QPSK	248
A.2.2.1.2	16-QAM	249
A.2.2.1.3	64-QAM	249
A.2.2.2	Partial RB allocation	249
A.2.2.2.1	QPSK	250
A.2.2.2.2	16-QAM	251
A.2.2.2.3	64-QAM	251
A.2.2.3	Void	251
A.2.3	Reference measurement channels for TDD	251
A.2.3.1	Full RB allocation	252
A.2.3.1.1	QPSK	252
A.2.3.1.2	16-QAM	252
A.2.3.1.3	64-QAM	252
A.2.3.2	Partial RB allocation	253
A.2.3.2.1	QPSK	253

A.2.3.2.2	16-QAM	254
A.2.3.2.3	64-QAM	254
A.2.3.3	Void	255
A.3	DL reference measurement channels	255
A.3.1	General	255
A.3.1.1	Overview of DL reference measurement channels	255
A.3.2	Reference measurement channel for receiver characteristics	260
A.3.3	Reference measurement channels for PDSCH performance requirements (FDD)	268
A.3.3.1	Single-antenna transmission (Common Reference Symbols)	268
A.3.3.2	Multi-antenna transmission (Common Reference Symbols)	274
A.3.3.2.1	Two antenna ports	274
A.3.3.2.2	Four antenna ports	275
A.3.3.3	Reference Measurement Channel for UE-Specific Reference Symbols	275
A.3.3.3.1	Two antenna port (CSI-RS)	275
A.3.3.3.2	Four antenna ports (CSI-RS)	276
A.3.4	Reference measurement channels for PDSCH performance requirements (TDD)	279
A.3.4.1	Single-antenna transmission (Common Reference Symbols)	279
A.3.4.2	Multi-antenna transmission (Common Reference Signals)	287
A.3.4.2.1	Two antenna ports	287
A.3.4.2.2	Four antenna ports	288
A.3.4.3	Reference Measurement Channels for UE-Specific Reference Symbols	288
A.3.4.3.1	Single antenna port (Cell Specific)	288
A.3.4.3.2	Two antenna ports (Cell Specific)	289
A.3.4.3.3	Two antenna ports (CSI-RS)	290
A.3.4.3.4	Four antenna ports (CSI-RS)	291
A.3.4.3.5	Eight antenna ports (CSI-RS)	292
A.3.5	Reference measurement channels for PDCCH/PCFICH performance requirements	295
A.3.5.1	FDD	295
A.3.5.2	TDD	295
A.3.6	Reference measurement channels for PHICH performance requirements	295
A.3.7	Reference measurement channels for PBCH performance requirements	296
A.3.8	Reference measurement channels for MBMS performance requirements	296
A.3.8.1	FDD	296
A.3.8.2	TDD	298
A.3.9	Reference measurement channels for sustained downlink data rate provided by lower layers	300
A.3.9.1	FDD	300
A.3.9.2	TDD	301
A.4	CSI reference measurement channels	302
A.5	OFDMA Channel Noise Generator (OCNG)	305
A.5.1	OCNG Patterns for FDD	305
A.5.1.1	OCNG FDD pattern 1: One sided dynamic OCNG FDD pattern	306
A.5.1.2	OCNG FDD pattern 2: Two sided dynamic OCNG FDD pattern	306
A.5.1.3	OCNG FDD pattern 3: 49 RB OCNG allocation with MBSFN in 10 MHz	307
A.5.1.4	OCNG FDD pattern 4: One sided dynamic OCNG FDD pattern for MBMS transmission	308
A.5.1.5	OCNG FDD pattern 5: One sided dynamic 16QAM modulated OCNG FDD pattern	308
A.5.1.6	OCNG FDD pattern 6: dynamic OCNG FDD pattern when user data is in 2 non-contiguous blocks	309
A.5.2	OCNG Patterns for TDD	310
A.5.2.1	OCNG TDD pattern 1: One sided dynamic OCNG TDD pattern	311
A.5.2.2	OCNG TDD pattern 2: Two sided dynamic OCNG TDD pattern	311
A.5.2.3	OCNG TDD pattern 3: 49 RB OCNG allocation with MBSFN in 10 MHz	312
A.5.2.4	OCNG TDD pattern 4: One sided dynamic OCNG TDD pattern for MBMS transmission	313
A.5.2.5	OCNG TDD pattern 5: One sided dynamic 16QAM modulated OCNG TDD pattern	313
A.5.2.6	OCNG TDD pattern 6: dynamic OCNG TDD pattern when user data is in 2 non-contiguous blocks	314
Annex B (normative):	Propagation conditions	316
B.1	Static propagation condition	316
B.2	Multi-path fading propagation conditions	316
B.2.1	Delay profiles	316
B.2.2	Combinations of channel model parameters	317

B.2.3	MIMO Channel Correlation Matrices	318
B.2.3.1	Definition of MIMO Correlation Matrices	318
B.2.3.2	MIMO Correlation Matrices at High, Medium and Low Level.....	319
B.2.3A	MIMO Channel Correlation Matrices using cross polarized antennas	321
B.2.3A.1	Definition of MIMO Correlation Matrices using cross polarized antennas	322
B.2.3A.2	Spatial Correlation Matrices using cross polarized antennas at eNB and UE sides.....	322
B.2.3A.2.1	Spatial Correlation Matrices at eNB side	322
B.2.3A.2.2	Spatial Correlation Matrices at UE side	322
B.2.3A.4	Beam steering approach.....	323
B.2.4	Propagation conditions for CQI tests.....	324
B.2.5	Void.....	324
B.2.6	MBSFN Propagation Channel Profile	324
B.3	High speed train scenario	325
B.4	Beamforming Model	326
B.4.1	Single-layer random beamforming (Antenna port 5, 7, or 8).....	326
B.4.2	Dual-layer random beamforming (antenna ports 7 and 8).....	327
B.4.3	Generic beamforming model (antenna ports 7-14).....	327
Annex C (normative): Downlink Physical Channels.....		329
C.1	General	329
C.2	Set-up	329
C.3	Connection	329
C.3.1	Measurement of Receiver Characteristics	329
C.3.2	Measurement of Performance requirements.....	330
C.3.3	Aggressor cell power allocation for Measurement of Performance Requirements when ABS is Configured.....	331
Annex D (normative): Characteristics of the interfering signal		332
D.1	General	332
D.2	Interference signals.....	332
Annex E (normative): Environmental conditions		333
E.1	General	333
E.2	Environmental	333
E.2.1	Temperature	333
E.2.2	Voltage	333
E.2.3	Vibration.....	334
Annex F (normative): Transmit modulation.....		335
F.1	Measurement Point.....	335
F.2	Basic Error Vector Magnitude measurement	335
F.3	Basic in-band emissions measurement.....	336
F.4	Modified signal under test.....	336
F.5	Window length	338
F.5.1	Timing offset	338
F.5.2	Window length	338
F.5.3	Window length for normal CP	339
F.5.4	Window length for Extended CP.....	339
F.5.5	Window length for PRACH	339
F.6	Averaged EVM	340
F.7	Spectrum Flatness	341

Annex G (informative):	Reference sensitivity level in lower SNR.....	342
G.1	General	342
G.2	Typical receiver sensitivity performance (QPSK)	342
G.3	Reference measurement channel for REFSENSE in lower SNR.....	345
Annex H (normative):	Modified MPR behavior.....	347
H.1	Indication of modified MPR behavior.....	347
Annex I (informative):	Change history	348
History		363

Foreword

This Technical Specification (TS) has been produced by the 3rd Generation Partnership Project (3GPP).

The contents of the present document are subject to continuing work within the TSG and may change following formal TSG approval. Should the TSG modify the contents of the present document, it will be re-released by the TSG with an identifying change of release date and an increase in version number as follows:

Version x.y.z

Where:

- x the first digit:
 - 1 presented to TSG for information;
 - 2 presented to TSG for approval;
 - 3 or greater indicates TSG approved document under change control.
- y the second digit is incremented for all changes of substance, i.e. technical enhancements, corrections, updates, etc.
- z the third digit is incremented when editorial only changes have been incorporated in the document.

1 Scope

. The present document establishes the minimum RF characteristics and minimum performance requirements for E-UTRA User Equipment (UE).

2 References

The following documents contain provisions which, through reference in this text, constitute provisions of the present document.

- References are either specific (identified by date of publication, edition number, version number, etc.) or non-specific.
- For a specific reference, subsequent revisions do not apply.
- For a non-specific reference, the latest version applies. In the case of a reference to a 3GPP document (including a GSM document), a non-specific reference implicitly refers to the latest version of that document *in the same Release as the present document*.

- [1] 3GPP TR 21.905: "Vocabulary for 3GPP Specifications".
- [2] ITU-R Recommendation SM.329-10, "Unwanted emissions in the spurious domain"
- [3] ITU-R Recommendation M.1545: "Measurement uncertainty as it applies to test limits for the terrestrial component of International Mobile Telecommunications-2000".
- [4] 3GPP TS 36.211: "Physical Channels and Modulation".
- [5] 3GPP TS 36.212: "Multiplexing and channel coding".
- [6] 3GPP TS 36.213: "Physical layer procedures".
- [7] 3GPP TS 36.331: " Requirements for support of radio resource management ".
- [8] 3GPP TS 36.307: " Requirements on User Equipments (UEs) supporting a release-independent frequency band".
- [9] 3GPP TS 36.423: "X2 application protocol (X2AP) ".

3 Definitions, symbols and abbreviations

3.1 Definitions

For the purposes of the present document, the terms and definitions given in TR 21.905 [1] and the following apply in the case of a single component carrier. A term defined in the present document takes precedence over the definition of the same term, if any, in TR 21.905 [1].

Aggregated Channel Bandwidth: The RF bandwidth in which a UE transmits and receives multiple contiguously aggregated carriers.

Aggregated Transmission Bandwidth Configuration: The number of resource block allocated within the aggregated channel bandwidth.

Carrier aggregation: Aggregation of two or more component carriers in order to support wider transmission bandwidths.

Carrier aggregation band: A set of one or more operating bands across which multiple carriers are aggregated with a specific set of technical requirements.

Carrier aggregation bandwidth class: A class defined by the aggregated transmission bandwidth configuration and maximum number of component carriers supported by a UE.

Carrier aggregation configuration: A combination of CA operating band(s) and CA bandwidth class(es) supported by a UE.

Channel edge: The lowest and highest frequency of the carrier, separated by the channel bandwidth.

Channel bandwidth: The RF bandwidth supporting a single E-UTRA RF carrier with the transmission bandwidth configured in the uplink or downlink of a cell. The channel bandwidth is measured in MHz and is used as a reference for transmitter and receiver RF requirements.

Contiguous carriers: A set of two or more carriers configured in a spectrum block where there are no RF requirements based on co-existence for un-coordinated operation within the spectrum block.

Contiguous resource allocation: A resource allocation of consecutive resource blocks within one carrier or across contiguously aggregated carriers. The gap between contiguously aggregated carriers due to the nominal channel spacing is allowed.

Inter-band carrier aggregation: Carrier aggregation of component carriers in different operating bands.

NOTE: Carriers aggregated in each band can be contiguous or non-contiguous.

Intra-band contiguous carrier aggregation: Contiguous carriers aggregated in the same operating band.

Intra-band non-contiguous carrier aggregation: Non-contiguous carriers aggregated in the same operating band.

Synchronized operation: Operation of TDD in two different systems, where no simultaneous uplink and downlink occur.

Unsynchronized operation: Operation of TDD in two different systems, where the conditions for synchronized operation are not met.

3.2 Symbols

For the purposes of the present document, the following symbols apply:

BW_{Channel}	Channel bandwidth
$BW_{\text{Channel_CA}}$	Aggregated channel bandwidth, expressed in MHz.
BW_{GB}	Virtual guard band to facilitate transmitter (receiver) filtering above / below edge CCs.
E_{RS}	Transmitted energy per RE for reference symbols during the useful part of the symbol, i.e. excluding the cyclic prefix, (average power normalized to the subcarrier spacing) at the eNode B transmit antenna connector
\hat{E}_s	The averaged received energy per RE of the wanted signal during the useful part of the symbol, i.e. excluding the cyclic prefix, at the UE antenna connector; average power is computed within a set of REs used for the transmission of physical channels (including user specific RSs when present), divided by the number of REs within the set, and normalized to the subcarrier spacing
F	Frequency
$F_{\text{Interferer (offset)}}$	Frequency offset of the interferer
$F_{\text{Interferer}}$	Frequency of the interferer
F_C	Frequency of the carrier centre frequency
F_{C_low}	The centre frequency of the <i>lowest carrier</i> , expressed in MHz.
F_{C_high}	The centre frequency of the <i>highest carrier</i> , expressed in MHz.
$F_{\text{DL_low}}$	The lowest frequency of the downlink operating band
$F_{\text{DL_high}}$	The highest frequency of the downlink operating band
$F_{\text{UL_low}}$	The lowest frequency of the uplink operating band
$F_{\text{UL_high}}$	The highest frequency of the uplink operating band
$F_{\text{edge_low}}$	The <i>lower edge</i> of aggregated channel bandwidth, expressed in MHz.
$F_{\text{edge_high}}$	The <i>higher edge</i> of aggregated channel bandwidth, expressed in MHz.
F_{offset}	Frequency offset from F_{C_high} to the <i>higher edge</i> or F_{C_low} to the <i>lower edge</i> .
$F_{\text{offset_NS_23}}$	Frequency offset in MHz needed if NS_23 is used
F_{OOB}	The boundary between the E-UTRA out of band emission and spurious emission domains.

I_o	The power spectral density of the total input signal (power averaged over the useful part of the symbols within the transmission bandwidth configuration, divided by the total number of RE for this configuration and normalised to the subcarrier spacing) at the UE antenna connector, including the own-cell downlink signal
I_{or}	The total transmitted power spectral density of the own-cell downlink signal (power averaged over the useful part of the symbols within the transmission bandwidth configuration, divided by the total number of RE for this configuration and normalised to the subcarrier spacing) at the eNode B transmit antenna connector
\hat{I}_{or}	The total received power spectral density of the own-cell downlink signal (power averaged over the useful part of the symbols within the transmission bandwidth configuration, divided by the total number of RE for this configuration and normalised to the subcarrier spacing) at the UE antenna connector
I_{ot}	The received power spectral density of the total noise and interference for a certain RE (average power obtained within the RE and normalized to the subcarrier spacing) as measured at the UE antenna connector
L _{CRB}	Transmission bandwidth which represents the length of a contiguous resource block allocation expressed in units of resource blocks
N_{cp}	Cyclic prefix length
N_{DL}	Downlink EARFCN
N_{oc}	The power spectral density of a white noise source (average power per RE normalised to the subcarrier spacing), simulating interference from cells that are not defined in a test procedure, as measured at the UE antenna connector
N_{oc1}	The power spectral density of a white noise source (average power per RE normalized to the subcarrier spacing), simulating interference in non-CRS symbols in ABS subframe from cells that are not defined in a test procedure, as measured at the UE antenna connector.
N_{oc2}	The power spectral density of a white noise source (average power per RE normalized to the subcarrier spacing), simulating interference in CRS symbols in ABS subframe from all cells that are not defined in a test procedure, as measured at the UE antenna connector.
N_{oc3}	The power spectral density of a white noise source (average power per RE normalised to the subcarrier spacing), simulating interference in non-ABS subframe from cells that are not defined in a test procedure, as measured at the UE antenna connector
$N_{Offs-DL}$	Offset used for calculating downlink EARFCN
$N_{Offs-UL}$	Offset used for calculating uplink EARFCN
N_{otx}	The power spectral density of a white noise source (average power per RE normalised to the subcarrier spacing) simulating eNode B transmitter impairments as measured at the eNode B transmit antenna connector
N_{RB}	Transmission bandwidth configuration, expressed in units of resource blocks
N_{RB_agg}	The number of the aggregated RBs within the fully allocated Aggregated Channel bandwidth.
N_{RB_alloc}	Total number of simultaneously transmitted resource blocks in Aggregated Channel Bandwidth configuration.
$N_{RB,c}$	The transmission bandwidth configuration of component carrier c , expressed in units of resource blocks
$N_{RB,largest\ BW}$	The largest transmission bandwidth configuration of the component carriers in the bandwidth combination, expressed in units of resource blocks
N_{UL}	Uplink EARFCN
R_{av}	Minimum average throughput per RB
P_{CMAX}	The configured maximum UE output power.
$P_{CMAX,c}$	The configured maximum UE output power for serving cell c .
P_{EMAX}	Maximum allowed UE output power signalled by higher layers. Same as IE $P-Max$, defined in [7].
$P_{EMAX,c}$	Maximum allowed UE output power signalled by higher layers for serving cell c . Same as IE $P-Max$, defined in [7].
$P_{Interferer}$	Modulated mean power of the interferer
$P_{PowerClass}$	$P_{PowerClass}$ is the nominal UE power (i.e., no tolerance).
P_{UMAX}	The measured configured maximum UE output power.
P_{uw}	Power of an unwanted DL signal
P_w	Power of a wanted DL signal
RB_{start}	Indicates the lowest RB index of transmitted resource blocks.
RB_{end}	Indicates highest RB index of transmitted resource blocks.

Δf_{OOB}	Δ Frequency of Out Of Band emission.
$\Delta R_{\text{IB},c}$	Allowed reference sensitivity relaxation due to support for inter-band CA operation, for serving cell c .
$\Delta T_{\text{IB},c}$	Allowed maximum configured output power relaxation due to support for inter-band CA operation, for serving cell c .
ΔT_{C}	Allowed operating band edge transmission power relaxation.
$\Delta T_{\text{C},c}$	Allowed operating band edge transmission power relaxation for serving cell c .
σ	Test specific auxiliary variable used for the purpose of downlink power allocation, defined in Annex C.3.2.

3.3 Abbreviations

For the purposes of the present document, the abbreviations given in TR 21.905 [1] and the following apply. An abbreviation defined in the present document takes precedence over the definition of the same abbreviation, if any, in TR 21.905 [1].

ABS	Almost Blank Subframe
ACLR	Adjacent Channel Leakage Ratio
ACS	Adjacent Channel Selectivity
A-MPR	Additional Maximum Power Reduction
AWGN	Additive White Gaussian Noise
BS	Base Station
CA	Carrier Aggregation
CA_X	CA for band X where X is the applicable E-UTRA operating band
CA_X-Y	CA for band X and Band Y where X and Y are the applicable E-UTRA operating band
CC	Component Carriers
CPE	Customer Premise Equipment
CPE_X	Customer Premise Equipment for E-UTRA operating band X
CW	Continuous Wave
DL	Downlink
EARFCN	E-UTRA Absolute Radio Frequency Channel Number
EPRE	Energy Per Resource Element
E-UTRA	Evolved UMTS Terrestrial Radio Access
EUTRAN	Evolved UMTS Terrestrial Radio Access Network
EVM	Error Vector Magnitude
FDD	Frequency Division Duplex
FRC	Fixed Reference Channel
HD-FDD	Half- Duplex FDD
MCS	Modulation and Coding Scheme
MOP	Maximum Output Power
MPR	Maximum Power Reduction
MSD	Maximum Sensitivity Degradation
OCNG	OFDMA Channel Noise Generator
OFDMA	Orthogonal Frequency Division Multiple Access
OOB	Out-of-band
PA	Power Amplifier
PCC	Primary Component Carrier
P-MPR	Power Management Maximum Power Reduction
PSS	Primary Synchronization Signal
PSS_RA	PSS-to-RS EPRE ratio for the channel PSS
RE	Resource Element
REFSENS	Reference Sensitivity power level
r.m.s	Root Mean Square
SCC	Secondary Component Carrier
SNR	Signal-to-Noise Ratio
SSS	Secondary Synchronization Signal
SSS_RA	SSS-to-RS EPRE ratio for the channel SSS
TDD	Time Division Duplex
UE	User Equipment
UL	Uplink
UL-MIMO	Up Link Multiple Antenna transmission

UMTS	Universal Mobile Telecommunications System
UTRA	UMTS Terrestrial Radio Access
UTRAN	UMTS Terrestrial Radio Access Network
xCH_RA	xCH-to-RS EPRE ratio for the channel xCH in all transmitted OFDM symbols not containing RS
xCH_RB	xCH-to-RS EPRE ratio for the channel xCH in all transmitted OFDM symbols containing RS

4 General

4.1 Relationship between minimum requirements and test requirements

The Minimum Requirements given in this specification make no allowance for measurement uncertainty. The test specification TS 36.521-1 Annex F defines Test Tolerances. These Test Tolerances are individually calculated for each test. The Test Tolerances are used to relax the Minimum Requirements in this specification to create Test Requirements.

The measurement results returned by the Test System are compared - without any modification - against the Test Requirements as defined by the shared risk principle.

The Shared Risk principle is defined in ITU-R M.1545 [3].

4.2 Applicability of minimum requirements

- a) In this specification the Minimum Requirements are specified as general requirements and additional requirements. Where the Requirement is specified as a general requirement, the requirement is mandated to be met in all scenarios
- b) For specific scenarios for which an additional requirement is specified, in addition to meeting the general requirement, the UE is mandated to meet the additional requirements.
- c) The reference sensitivity power levels defined in subclause 7.3 are valid for the specified reference measurement channels.
- d) Note: Receiver sensitivity degradation may occur when:
 - 1) The UE simultaneously transmits and receives with bandwidth allocations less than the transmission bandwidth configuration (see Figure 5.6-1), and
 - 2) Any part of the downlink transmission bandwidth is within an uplink transmission bandwidth from the downlink center subcarrier.
- e) The spurious emissions power requirements are for the long term average of the power. For the purpose of reducing measurement uncertainty it is acceptable to average the measured power over a period of time sufficient to reduce the uncertainty due to the statistical nature of the signal.

4.3 Void

4.3A Applicability of minimum requirements (CA, UL-MIMO)

The requirements in clauses 5, 6 and 7 which are specific to CA and UL-MIMO are specified as suffix A, B, C, D where;

- a) Suffix A additional requirements need to support CA
- b) Suffix B additional requirements need to support UL-MIMO
- c) Suffix C additional requirements need to support TBD

d) Suffix D additional requirements need to support TBD

A terminal which supports the above features needs to meet both the general requirements and the additional requirement applicable to the additional sub-clause (suffix A, B, C and D) in clauses 5, 6 and 7. Where there is a difference in requirement between the general requirements and the additional subclause requirements (suffix A, B, C and D) in clauses 5, 6 and 7, the tighter requirements are applicable unless stated otherwise in the additional subclause.

A terminal which supports more than one feature (CA and UL-MIMO) in clauses 5, 6 and 7 shall meet all of the separate corresponding requirements.

A terminal which supports CA, for each supported CA configuration, shall support Pcell transmissions in each of the aggregated Component Carriers unless indicated otherwise in clause 5.6A.1.

4.4 RF requirements in later releases

The standardisation of new frequency bands may be independent of a release. However, in order to implement a UE that conforms to a particular release but supports a band of operation that is specified in a later release, it is necessary to specify some extra requirements. TS 36.307 [8] specifies requirements on UEs supporting a frequency band that is independent of release.

NOTE: For terminals conforming to the 3GPP release of the present document, some RF requirements in later releases may be mandatory independent of whether the UE supports the bands specified in later releases or not. The set of requirements from later releases that is also mandatory for UEs conforming to the 3GPP release of the present document is determined by regional regulation.

5 Operating bands and channel arrangement

5.1 General

The channel arrangements presented in this clause are based on the operating bands and channel bandwidths defined in the present release of specifications.

NOTE: Other operating bands and channel bandwidths may be considered in future releases.

5.2 Void

5.3 Void

5.4 Void

5.5 Operating bands

E-UTRA is designed to operate in the operating bands defined in Table 5.5-1.

Table 5.5-1 E-UTRA operating bands

E-UTRA Operating Band	Uplink (UL) operating band BS receive UE transmit	Downlink (DL) operating band BS transmit UE receive	Duplex Mode
	F _{UL_low} – F _{UL_high}	F _{DL_low} – F _{DL_high}	
1	1920 MHz – 1980 MHz	2110 MHz – 2170 MHz	FDD
2	1850 MHz – 1910 MHz	1930 MHz – 1990 MHz	FDD
3	1710 MHz – 1785 MHz	1805 MHz – 1880 MHz	FDD
4	1710 MHz – 1755 MHz	2110 MHz – 2155 MHz	FDD
5	824 MHz – 849 MHz	869 MHz – 894MHz	FDD
6 ¹	830 MHz – 840 MHz	875 MHz – 885 MHz	FDD
7	2500 MHz – 2570 MHz	2620 MHz – 2690 MHz	FDD
8	880 MHz – 915 MHz	925 MHz – 960 MHz	FDD
9	1749.9 MHz – 1784.9 MHz	1844.9 MHz – 1879.9 MHz	FDD
10	1710 MHz – 1770 MHz	2110 MHz – 2170 MHz	FDD
11	1427.9 MHz – 1447.9 MHz	1475.9 MHz – 1495.9 MHz	FDD
12	699 MHz – 716 MHz	729 MHz – 746 MHz	FDD
13	777 MHz – 787 MHz	746 MHz – 756 MHz	FDD
14	788 MHz – 798 MHz	758 MHz – 768 MHz	FDD
15	Reserved	Reserved	FDD
16	Reserved	Reserved	FDD
17	704 MHz – 716 MHz	734 MHz – 746 MHz	FDD
18	815 MHz – 830 MHz	860 MHz – 875 MHz	FDD
19	830 MHz – 845 MHz	875 MHz – 890 MHz	FDD
20	832 MHz – 862 MHz	791 MHz – 821 MHz	FDD
21	1447.9 MHz – 1462.9 MHz	1495.9 MHz – 1510.9 MHz	FDD
22	3410 MHz – 3490 MHz	3510 MHz – 3590 MHz	FDD
23	2000 MHz – 2020 MHz	2180 MHz – 2200 MHz	FDD
24 ¹⁷	1626.5 MHz – 1660.5 MHz	1525 MHz – 1559 MHz	FDD
25	1850 MHz – 1915 MHz	1930 MHz – 1995 MHz	FDD
...			
33	1900 MHz – 1920 MHz	1900 MHz – 1920 MHz	TDD
34	2010 MHz – 2025 MHz	2010 MHz – 2025 MHz	TDD
35	1850 MHz – 1910 MHz	1850 MHz – 1910 MHz	TDD
36	1930 MHz – 1990 MHz	1930 MHz – 1990 MHz	TDD
37	1910 MHz – 1930 MHz	1910 MHz – 1930 MHz	TDD
38	2570 MHz – 2620 MHz	2570 MHz – 2620 MHz	TDD
39	1880 MHz – 1920 MHz	1880 MHz – 1920 MHz	TDD
40	2300 MHz – 2400 MHz	2300 MHz – 2400 MHz	TDD
41	2496 MHz – 2690 MHz	2496 MHz – 2690 MHz	TDD
42	3400 MHz – 3600 MHz	3400 MHz – 3600 MHz	TDD
43	3600 MHz – 3800 MHz	3600 MHz – 3800 MHz	TDD
NOTE 1: Band 6 is not applicable			
NOTE 2: Void			
NOTE 3: Void			
NOTE 4: Void			
NOTE 5: Void			
NOTE 6: Void			
NOTE 7: Void			
NOTE 8: Void			
NOTE 9: Void			
NOTE 10: Void			
NOTE 11: Void			
NOTE 12: Void			
NOTE 13: Void			
NOTE 14: Void			
NOTE 15: Void			
NOTE 16: Void			
NOTE 17: DL operation in this band is restricted to 1526 – 1536 MHz and UL operation is restricted to 1627.5 – 1637.5 MHz and 1646.5 – 1656.5 MHz.			

5.5A Operating bands for CA

E-UTRA carrier aggregation is designed to operate in the operating bands defined in Tables 5.5A-1 and 5.5A-2.

Table 5.5A-1: Intra-band contiguous CA operating bands

E-UTRA CA Band	E-UTRA Band	Uplink (UL) operating band			Downlink (DL) operating band			Duplex Mode
		BS receive / UE transmit			BS transmit / UE receive			
		F _{UL_low}	–	F _{UL_high}	F _{DL_low}	–	F _{DL_high}	
CA_1	1	1920 MHz	–	1980 MHz	2110 MHz	–	2170 MHz	FDD
CA_40	40	2300 MHz	–	2400 MHz	2300 MHz	–	2400 MHz	TDD

Table 5.5A-2: Inter-band CA operating bands

E-UTRA CA Band	E-UTRA Band	Uplink (UL) operating band			Downlink (DL) operating band			Duplex Mode
		BS receive / UE transmit			BS transmit / UE receive			
		F _{UL_low}	–	F _{UL_high}	F _{DL_low}	–	F _{DL_high}	
CA_1-5	1	1920 MHz	–	1980 MHz	2110 MHz	–	2170 MHz	FDD
	5	824 MHz	–	849 MHz	869 MHz	–	894 MHz	

5.5B Operating bands for UL-MIMO

E-UTRA UL-MIMO is designed to operate in the operating bands defined in Table 5.5-1.

Table 5.5B-1: Void

5.6 Channel bandwidth

Requirements in present document are specified for the channel bandwidths listed in Table 5.6-1.

Table 5.6-1: Transmission bandwidth configuration N_{RB} in E-UTRA channel bandwidths

Channel bandwidth $BW_{Channel}$ [MHz]	1.4	3	5	10	15	20
Transmission bandwidth configuration N_{RB}	6	15	25	50	75	100

Figure 5.6-1 shows the relation between the Channel bandwidth ($BW_{Channel}$) and the Transmission bandwidth configuration (N_{RB}). The channel edges are defined as the lowest and highest frequencies of the carrier separated by the channel bandwidth, i.e. at $F_C \pm BW_{Channel}/2$.

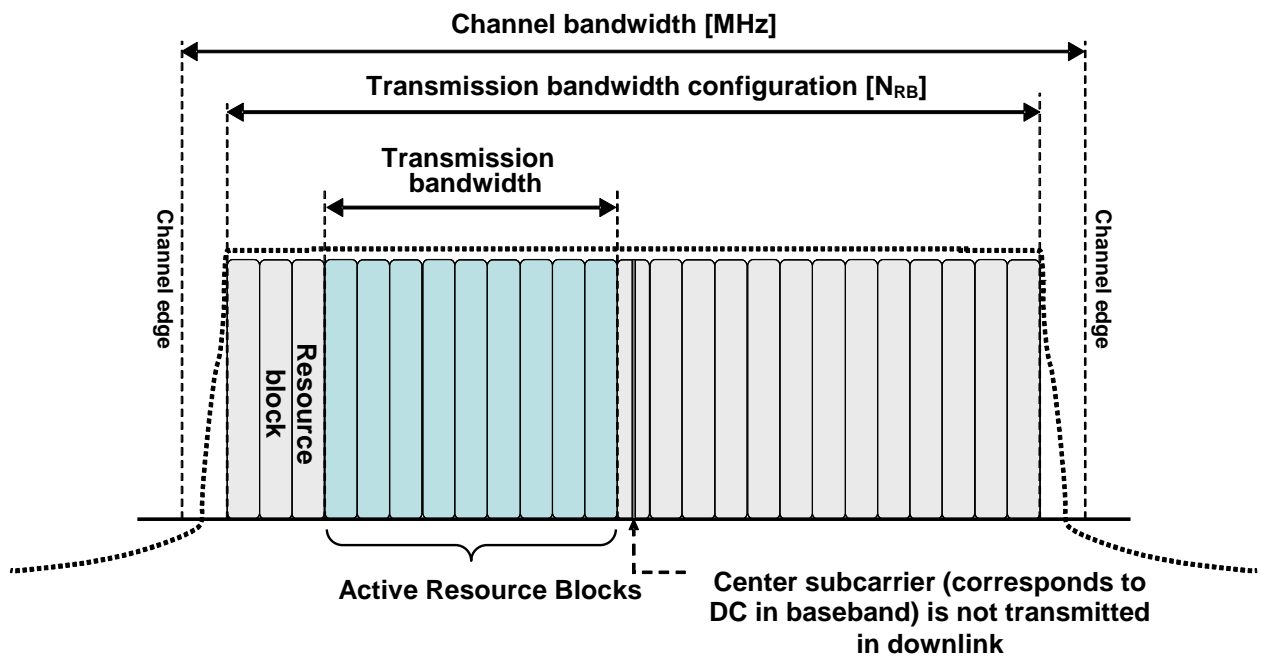

Figure 5.6-1: Definition of channel bandwidth and transmission bandwidth configuration for one E-UTRA carrier

5.6.1 Channel bandwidths per operating band

a) The requirements in this specification apply to the combination of channel bandwidths and operating bands shown in Table 5.6.1-1. The transmission bandwidth configuration in Table 5.6.1-1 shall be supported for each of the specified channel bandwidths. The same (symmetrical) channel bandwidth is specified for both the TX and RX path.

Table 5.6.1-1: E-UTRA channel bandwidth

E-UTRA band / Channel bandwidth						
E-UTRA Band	1.4 MHz	3 MHz	5 MHz	10 MHz	15 MHz	20 MHz
1			Yes	Yes	Yes	Yes
2	Yes	Yes	Yes	Yes	Yes ¹	Yes ¹
3	Yes	Yes	Yes	Yes	Yes ¹	Yes ¹
4	Yes	Yes	Yes	Yes	Yes	Yes
5	Yes	Yes	Yes	Yes ¹		
6			Yes	Yes ¹		
7			Yes	Yes	Yes ²	Yes ^{1,2}
8	Yes	Yes	Yes	Yes ¹		
9			Yes	Yes	Yes ¹	Yes ¹
10			Yes	Yes	Yes	Yes
11			Yes	Yes ¹		
12	Yes	Yes	Yes ¹	Yes ¹		
13			Yes ¹	Yes ¹		
14			Yes ¹	Yes ¹		
...						
17			Yes ¹	Yes ¹		
18			Yes	Yes ¹	Yes ¹	
19			Yes	Yes ¹	Yes ¹	
20			Yes	Yes ¹	Yes ¹	Yes ¹
21			Yes	Yes ¹	Yes ¹	
22			Yes	Yes	Yes ¹	Yes ¹
23	Yes	Yes	Yes	Yes	Yes ¹	Yes ¹
24			Yes	Yes		
25	Yes	Yes	Yes	Yes	Yes ¹	Yes ¹
...						
33			Yes	Yes	Yes	Yes
34			Yes	Yes	Yes	
35	Yes	Yes	Yes	Yes	Yes	Yes
36	Yes	Yes	Yes	Yes	Yes	Yes
37			Yes	Yes	Yes	Yes
38			Yes	Yes	Yes ²	Yes ²
39			Yes	Yes	Yes	Yes
40			Yes	Yes	Yes	Yes
41			Yes	Yes	Yes	Yes
42			Yes	Yes	Yes	Yes
43			Yes	Yes	Yes	Yes
NOTE 1: ¹ refers to the bandwidth for which a relaxation of the specified UE receiver sensitivity requirement (subclause 7.3) is allowed.						
NOTE 2: ² refers to the bandwidth for which the uplink transmission bandwidth can be restricted by the network for some channel assignments in FDD/TDD co-existence scenarios in order to meet unwanted emissions requirements (Clause 6.6.3.2).						

b) The use of different (asymmetrical) channel bandwidth for the TX and RX is not precluded and is intended to form part of a later release.

5.6A Channel bandwidth for CA

For intra-band contiguous carrier aggregation *Aggregated Channel Bandwidth*, *Aggregated Transmission Bandwidth Configuration* and *Guard Bands* are defined as follows, see Figure 5.6A-1.

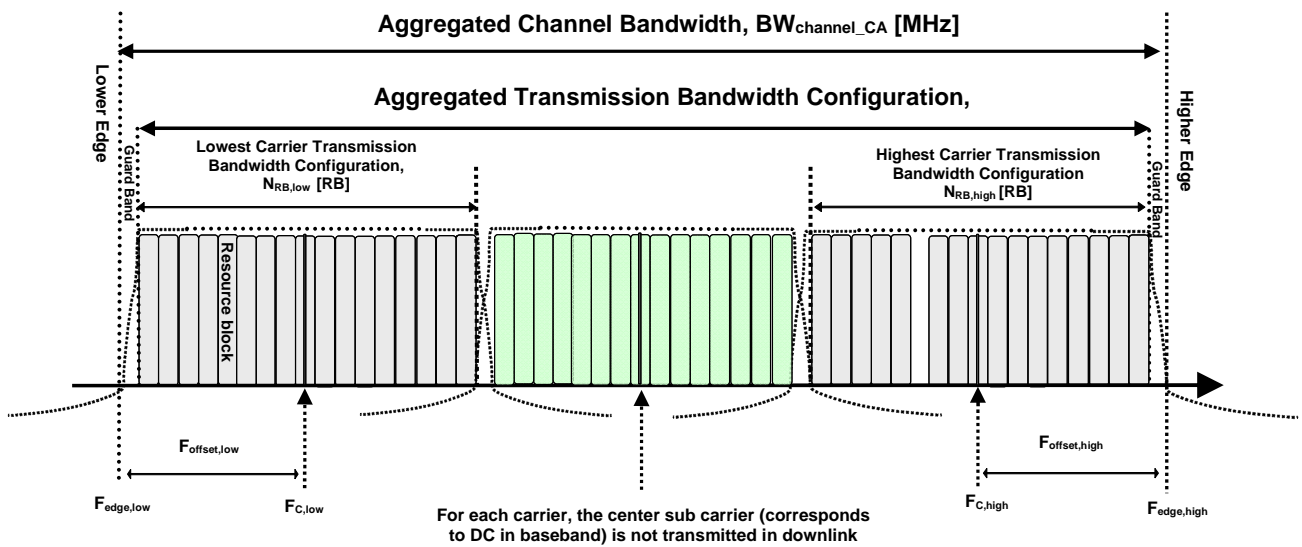

Figure 5.6A-1. Definition of Aggregated channel bandwidth and aggregated channel bandwidth edges

The *aggregated channel bandwidth*, $BW_{Channel_CA}$, is defined as

$$BW_{Channel_CA} = F_{edge,high} - F_{edge,low} \text{ [MHz]}.$$

The lower bandwidth edge $F_{edge,low}$ and the upper bandwidth edge $F_{edge,high}$ of the aggregated channel bandwidth are used as frequency reference points for transmitter and receiver requirements and are defined by

$$F_{edge,low} = F_{C,low} - F_{offset,low}$$

$$F_{edge,high} = F_{C,high} + F_{offset,high}$$

The lower and upper frequency offsets depend on the transmission bandwidth configurations of the lowest and highest assigned edge component carrier and are defined as

$$F_{offset,low} = (0.18N_{RB,low} + \Delta f_1) / 2 + BW_{GB} \text{ [MHz]}$$

$$F_{offset,high} = (0.18N_{RB,high} + \Delta f_1) / 2 + BW_{GB} \text{ [MHz]}$$

where $\Delta f_1 = \Delta f$ for the downlink with Δf the subcarrier spacing and $\Delta f_1 = 0$ for the uplink, while $N_{RB,low}$ and $N_{RB,high}$ are the transmission bandwidth configurations according to Table 5.6-1 for the lowest and highest assigned component carrier, respectively. BW_{GB} denotes the *Nominal Guard Band* and is defined in Table 5.6A-1, and the factor 0.18 is the PRB bandwidth in MHz.

NOTE: The values of $BW_{Channel_CA}$ for UE and BS are the same if the lowest and the highest component carriers are identical.

Aggregated Transmission Bandwidth Configuration is the number of the aggregated RBs within the fully allocated Aggregated Channel bandwidth and is defined per CA Bandwidth Class (Table 5.6A-1).

Table 5.6A-1: CA bandwidth classes and corresponding nominal guard bands

CA Bandwidth Class	Aggregated Transmission Bandwidth Configuration	Number of contiguous CC	Nominal Guard Band BW_{GB}
A	$N_{RB,agg} \leq 100$	1	$0.05BW_{Channel(1)} - 0.5\Delta f_1$
B	$N_{RB,agg} \leq 100$	2	FFS
C	$100 < N_{RB,agg} \leq 200$	2	$0.05 \max(BW_{Channel(1)}, BW_{Channel(2)}) - 0.5\Delta f_1$
D	$200 < N_{RB,agg} \leq 300$	3	NOTE 2
E	$300 < N_{RB,agg} \leq 400$	4	NOTE 2
F	$400 < N_{RB,agg} \leq 500$	5	NOTE 2
NOTE 1: $BW_{Channel(1)}$ and $BW_{Channel(2)}$ are channel bandwidths of two E-UTRA component carriers according to Table 5.6-1 and $\Delta f_1 = \Delta f$ for the downlink with Δf the subcarrier spacing while $\Delta f_1 = 0$ for the uplink.			
NOTE 2: Applicable for later releases.			

The channel spacing between centre frequencies of contiguously aggregated component carriers is defined in subclause 5.7.1A

5.6A.1 Channel bandwidths per operating band for CA

The requirements for carrier aggregation in this specification are defined for carrier aggregation configurations with associated bandwidth combination sets. For inter-band carrier aggregation, a *carrier aggregation configuration* is a combination of operating bands, each supporting a carrier aggregation bandwidth class. For intra-band contiguous carrier aggregation, a carrier aggregation configuration is a single operating band supporting a carrier aggregation bandwidth class.

For each carrier aggregation configuration, requirements are specified for all bandwidth combinations contained in a *bandwidth combination set*, which is indicated per supported band combination in the UE radio access capability. A UE can indicate support of several bandwidth combination sets per band combination. Requirements for intra-band contiguous carrier aggregation are defined for the carrier aggregation configurations and bandwidth combination sets specified in Table 5.6A.1-1. Requirements for inter-band carrier aggregation are defined for the carrier aggregation configurations and bandwidth combination sets specified in Table 5.6A.1-2.

The DL component carrier combinations for a given CA configuration shall be symmetrical in relation to channel centre unless stated otherwise in Table 5.6A.1-1 or 5.6A.1-2.

Table 5.6A.1-1: E-UTRA CA configurations and bandwidth combination sets defined for intra-band contiguous CA

E-UTRA CA configuration / Bandwidth combination set					
E-UTRA CA configuration	Uplink CA configurations (NOTE 3)	Component carriers in order of increasing carrier frequency		Maximum aggregated bandwidth [MHz]	Bandwidth combination set
		Channel bandwidths for carrier [MHz]	Channel bandwidths for carrier [MHz]		
CA_1C	CA_1C	15	15	40	0
		20	20		
CA_40C	CA_40C	10	20	40	0
		15	15		
		20	10, 20		
NOTE 1: The CA configuration refers to an operating band and a CA bandwidth class specified in Table 5.6A-1 (the indexing letter). Absence of a CA bandwidth class for an operating band implies support of all classes.					
NOTE 2: For the supported CC bandwidth combinations, the CC downlink and uplink bandwidths are equal.					
NOTE 3: Uplink CA configurations are the configurations supported by the present release of specifications.					

Table 5.6A.1-2: E-UTRA CA configurations and bandwidth combination sets defined for inter-band CA

E-UTRA CA configuration / Bandwidth combination set										
E-UTRA CA configuration	Uplink CA configurations (NOTE 4)	E-UTRA bands	1.4 MHz	3 MHz	5 MHz	10 MHz	15 MHz	20 MHz	Maximum aggregated bandwidth [MHz]	Bandwidth combination set
CA_1A-5A	-	1				Yes			20	0
		5				Yes				
NOTE 1: The CA Configuration refers to a combination of an operating band and a CA bandwidth class specified in Table 5.6A-1 (the indexing letter). Absence of a CA bandwidth class for an operating band implies support of all classes.										
NOTE 2: For each band combination, all combinations of indicated bandwidths belong to the set										
NOTE 3: For the supported CC bandwidth combinations, the CC downlink and uplink bandwidths are equal.										
NOTE 4: Uplink CA configurations are the configurations supported by the present release of specifications.										

5.6B Channel bandwidth for UL-MIMO

The requirements specified in subclause 5.6 are applicable to UE supporting UL-MIMO.

5.6B.1 Void

5.7 Channel arrangement

5.7.1 Channel spacing

The spacing between carriers will depend on the deployment scenario, the size of the frequency block available and the channel bandwidths. The nominal channel spacing between two adjacent E-UTRA carriers is defined as following:

$$\text{Nominal Channel spacing} = (BW_{\text{Channel}(1)} + BW_{\text{Channel}(2)})/2$$

where $BW_{\text{Channel}(1)}$ and $BW_{\text{Channel}(2)}$ are the channel bandwidths of the two respective E-UTRA carriers. The channel spacing can be adjusted to optimize performance in a particular deployment scenario.

5.7.1A Channel spacing for CA

For intra-band contiguous carrier aggregation bandwidth class C, the nominal channel spacing between two adjacent E-UTRA component carriers is defined as the following:

$$\text{Nominal channel spacing} = \left\lfloor \frac{BW_{\text{Channel}(1)} + BW_{\text{Channel}(2)} - 0.1|BW_{\text{Channel}(1)} - BW_{\text{Channel}(2)}|}{0.6} \right\rfloor 0.3 \text{ [MHz]}$$

where $BW_{\text{Channel}(1)}$ and $BW_{\text{Channel}(2)}$ are the channel bandwidths of the two respective E-UTRA component carriers according to Table 5.6-1 with values in MHz. The channel spacing for intra-band contiguous carrier aggregation can be adjusted to any multiple of 300 kHz less than the nominal channel spacing to optimize performance in a particular deployment scenario.

5.7.2 Channel raster

The channel raster is 100 kHz for all bands, which means that the carrier centre frequency must be an integer multiple of 100 kHz.

5.7.2A Channel raster for CA

For carrier aggregation the channel raster is 100 kHz for all bands, which means that the carrier centre frequency must be an integer multiple of 100 kHz.

5.7.3 Carrier frequency and EARFCN

The carrier frequency in the uplink and downlink is designated by the E-UTRA Absolute Radio Frequency Channel Number (EARFCN) in the range 0 - 65535. The relation between EARFCN and the carrier frequency in MHz for the downlink is given by the following equation, where F_{DL_low} and $N_{Offs-DL}$ are given in Table 5.7.3-1 and N_{DL} is the downlink EARFCN.

$$F_{DL} = F_{DL_low} + 0.1(N_{DL} - N_{Offs-DL})$$

The relation between EARFCN and the carrier frequency in MHz for the uplink is given by the following equation where F_{UL_low} and $N_{Offs-UL}$ are given in Table 5.7.3-1 and N_{UL} is the uplink EARFCN.

$$F_{UL} = F_{UL_low} + 0.1(N_{UL} - N_{Offs-UL})$$

Table 5.7.3-1: E-UTRA channel numbers

E-UTRA Operating Band	Downlink			Uplink		
	F_{DL_low} (MHz)	$N_{Offs-DL}$	Range of N_{DL}	F_{UL_low} (MHz)	$N_{Offs-UL}$	Range of N_{UL}
1	2110	0	0 – 599	1920	18000	18000 – 18599
2	1930	600	600 – 1199	1850	18600	18600 – 19199
3	1805	1200	1200 – 1949	1710	19200	19200 – 19949
4	2110	1950	1950 – 2399	1710	19950	19950 – 20399
5	869	2400	2400 – 2649	824	20400	20400 – 20649
6	875	2650	2650 – 2749	830	20650	20650 – 20749
7	2620	2750	2750 – 3449	2500	20750	20750 – 21449
8	925	3450	3450 – 3799	880	21450	21450 – 21799
9	1844.9	3800	3800 – 4149	1749.9	21800	21800 – 22149
10	2110	4150	4150 – 4749	1710	22150	22150 – 22749
11	1475.9	4750	4750 – 4949	1427.9	22750	22750 – 22949
12	729	5010	5010 - 5179	699	23010	23010 - 23179
13	746	5180	5180 – 5279	777	23180	23180 – 23279
14	758	5280	5280 – 5379	788	23280	23280 – 23379

...						
17	734	5730	5730 – 5849	704	23730	23730 - 23849
18	860	5850	5850 – 5999	815	23850	23850 – 23999
19	875	6000	6000 – 6149	830	24000	24000 – 24149
20	791	6150	6150 – 6449	832	24150	24150 – 24449
21	1495.9	6450	6450 – 6599	1447.9	24450	24450 – 24599
22	3510	6600	6600 – 7399	3410	24600	24600 – 25399
23	2180	7500	7500 – 7699	2000	25500	25500 – 25699
24	1525	7700	7700 - 8039	1626.5	25700	25700 – 26039
25	1930	8040	8040 - 8689	1850	26040	26040 - 26689
...						
33	1900	36000	36000 – 36199	1900	36000	36000 – 36199
34	2010	36200	36200 – 36349	2010	36200	36200 – 36349
35	1850	36350	36350 – 36949	1850	36350	36350 – 36949
36	1930	36950	36950 – 37549	1930	36950	36950 – 37549
37	1910	37550	37550 – 37749	1910	37550	37550 – 37749
38	2570	37750	37750 – 38249	2570	37750	37750 – 38249
39	1880	38250	38250 – 38649	1880	38250	38250 – 38649
40	2300	38650	38650 – 39649	2300	38650	38650 – 39649
41	2496	39650	39650 – 41589	2496	39650	39650 – 41589
42	3400	41590	41590 – 43589	3400	41590	41590 – 43589
43	3600	43590	43590 – 45589	3600	43590	43590 – 45589
NOTE:	The channel numbers that designate carrier frequencies so close to the operating band edges that the carrier extends beyond the operating band edge shall not be used. This implies that the first 7, 15, 25, 50, 75 and 100 channel numbers at the lower operating band edge and the last 6, 14, 24, 49, 74 and 99 channel numbers at the upper operating band edge shall not be used for channel bandwidths of 1.4, 3, 5, 10, 15 and 20 MHz respectively.					

5.7.4 TX–RX frequency separation

a) The default E-UTRA TX channel (carrier centre frequency) to RX channel (carrier centre frequency) separation is specified in Table 5.7.4-1 for the TX and RX channel bandwidths defined in Table 5.6.1-1

Table 5.7.4-1: Default UE TX-RX frequency separation

E-UTRA Operating Band	TX - RX carrier centre frequency separation
1	190 MHz
2	80 MHz.
3	95 MHz.
4	400 MHz
5	45 MHz
6	45 MHz
7	120 MHz
8	45 MHz
9	95 MHz
10	400 MHz
11	48 MHz
12	30 MHz
13	-31 MHz
14	-30 MHz
17	30 MHz
18	45 MHz
19	45 MHz
20	-41 MHz
21	48 MHz
22	100 MHz
23	180 MHz
24	-101.5, -120.5 MHz
25	80 MHz

b) The use of other TX channel to RX channel carrier centre frequency separation is not precluded and is intended to form part of a later release.

5.7.4A TX–RX frequency separation for CA

For intra-band contiguous carrier aggregation, the same TX-RX frequency separation as specified in Table 5.7.4-1 is applied to PCC and SCC, respectively.

6 Transmitter characteristics

6.1 General

Unless otherwise stated, the transmitter characteristics are specified at the antenna connector of the UE with a single or multiple transmit antenna(s). For UE with integral antenna only, a reference antenna with a gain of 0 dBi is assumed.

6.2 Transmit power

6.2.1 Void

6.2.2 UE maximum output power

The following UE Power Classes define the maximum output power for any transmission bandwidth within the channel bandwidth for non CA configuration and UL-MIMO unless otherwise stated. The period of measurement shall be at least one sub frame (1ms).

Table 6.2.2-1: UE Power Class

EUTRA band	Class 1 (dBm)	Tolerance (dB)	Class 2 (dBm)	Tolerance (dB)	Class 3 (dBm)	Tolerance (dB)	Class 4 (dBm)	Tolerance (dB)
1					23	±2		
2					23	±2 ²		
3					23	±2 ²		
4					23	±2		
5					23	±2		
6					23	±2		
7					23	±2 ²		
8					23	±2 ²		
9					23	±2		
10					23	±2		
11					23	±2		
12					23	±2 ²		
13					23	±2		
14					23	±2		
17					23	±2		
18					23	±2		
19					23	±2		
20					23	±2 ²		
21					23	±2		
22					23	+2/-3.5 ²		
23					23 ⁵	±2 ⁵		
24					23	+2/-3 ²		
25					23	±2 ²		
...								
33					23	±2		
34					23	±2		
35					23	±2		
36					23	±2		
37					23	±2		
38					23	±2		
39					23	±2		
40					23	±2		
41					23	±2 ²		
42					23	+2/-3		
43					23	+2/-3		
<p>NOTE 1: Void</p> <p>NOTE 2: ² refers to the transmission bandwidths (Figure 5.6-1) confined within F_{UL_low} and $F_{UL_low} + 4$ MHz or $F_{UL_high} - 4$ MHz and F_{UL_high}, the maximum output power requirement is relaxed by reducing the lower tolerance limit by 1.5 dB</p> <p>NOTE 3: For the UE which supports both Band 11 and Band 21 operating frequencies, the tolerance is FFS.</p> <p>NOTE 4: $P_{PowerClass}$ is the maximum UE power specified without taking into account the tolerance</p> <p>NOTE 5: When NS_20 is signalled, the total output power within 2000-2005 MHz shall be limited to 7 dBm.</p>								

6.2.2A UE maximum output power for CA

The following UE Power Classes define the maximum output power for any transmission bandwidth within the aggregated channel bandwidth.

The maximum output power is measured as the sum of the maximum output power at each UE antenna connector. The period of measurement shall be at least one sub frame (1ms).

For inter-band carrier aggregation with uplink assigned to one E-UTRA band the requirements in subclause 6.2.2 apply.

For intra-band contiguous carrier aggregation the maximum output power is specified in Table 6.2.2A-1.

Table 6.2.2A-1: CA UE Power Class

E-UTRA CA Configuration	Class 1 (dBm)	Tolerance (dB)	Class 2 (dBm)	Tolerance (dB)	Class 3 (dBm)	Tolerance (dB)	Class 4 (dBm)	Tolerance (dB)
CA_1C					23	+2/-2		
CA_40C					23	+2/-2		
NOTE 1: Void								
NOTE 2: If all transmitted resource blocks (Figure 5.6 A -1) over all component carriers are confined within F_{UL_low} and $F_{UL_low} + 4$ MHz or/and $F_{UL_high} - 4$ MHz and F_{UL_high} , the maximum output power requirement is relaxed by reducing the lower tolerance limit by 1.5 dB								
NOTE 3: $P_{PowerClass}$ is the maximum UE power specified without taking into account the tolerance								
NOTE 4: For intra-band contiguous carrier aggregation the maximum power requirement should apply to the total transmitted power over all component carriers (per UE).								

6.2.2B UE maximum output power for UL-MIMO

For UE with two transmit antenna connectors in closed-loop spatial multiplexing scheme, the maximum output power for any transmission bandwidth within the channel bandwidth is specified in Table 6.2.2B-1. The requirements shall be met with the UL-MIMO configurations specified in Table 6.2.2B-2. For UE supporting UL-MIMO, the maximum output power is measured as the sum of the maximum output power at each UE antenna connector. The period of measurement shall be at least one sub frame (1ms).

Table 6.2.2B-1: UE Power Class for UL-MIMO in closed loop spatial multiplexing scheme

EUTRA band	Class 1 (dBm)	Tolerance (dB)	Class 2 (dBm)	Tolerance (dB)	Class 3 (dBm)	Tolerance (dB)	Class 4 (dBm)	Tolerance (dB)
1					23	+2/-3		
2					23	+2/-3 ²		
3					23	+2/-3 ²		
4					23	+2/-3		
5					23	+2/-3		
6					23	+2/-3		
7					23	+2/-3 ²		
8					23	+2/-3 ²		
9					23	+2/-3		
10					23	+2/-3		
11					23	+2/-3		
12					23	+2/-3 ²		
13					23	+2/-3		
14					23	+2/-3		
17					23	+2/-3		
18					23	+2/-3		
19					23	+2/-3		
20					23	+2/-3 ²		
21					23	+2/-3		
22					23	+2/-4.5 ²		
...								
23					23	+2/-3		
24					23	+2/-3		
25					23	+2/-3 ²		
...								
33					23	+2/-3		
34					23	+2/-3		
35					23	+2/-3		
36					23	+2/-3		
37					23	+2/-3		
38					23	+2/-3		
39					23	+2/-3		
40					23	+2/-3		
41					23	+2/-3 ²		
42					23	+2/-4		
43					23	+2/-4		
NOTE 1: Void NOTE 2: ² refers to the transmission bandwidths (Figure 5.6-1) confined within F_{UL_low} and $F_{UL_low} + 4$ MHz or $F_{UL_high} - 4$ MHz and F_{UL_high} , the maximum output power requirement is relaxed by reducing the lower tolerance limit by 1.5 dB NOTE 3: For the UE which supports both Band 11 and Band 21 operating frequencies, the tolerance is FFS. NOTE 4: $P_{PowerClass}$ is the maximum UE power specified without taking into account the tolerance								

Table 6.2.2B-2: UL-MIMO configuration in closed-loop spatial multiplexing scheme

Transmission mode	DCI format	Codebook Index
Mode 2	DCI format 4	Codebook index 0

If UE is configured for transmission on single-antenna port, the requirements in subclause 6.2.2 apply.

6.2.3 UE maximum output power for modulation / channel bandwidth

For UE Power Class 3, the allowed Maximum Power Reduction (MPR) for the maximum output power in Table 6.2.2-1 due to higher order modulation and transmit bandwidth configuration (resource blocks) is specified in Table 6.2.3-1.

Table 6.2.3-1: Maximum Power Reduction (MPR) for Power Class 3

Modulation	Channel bandwidth / Transmission bandwidth (N_{RB})						MPR (dB)
	1.4 MHz	3.0 MHz	5 MHz	10 MHz	15 MHz	20 MHz	
QPSK	> 5	> 4	> 8	> 12	> 16	> 18	≤ 1
16 QAM	≤ 5	≤ 4	≤ 8	≤ 12	≤ 16	≤ 18	≤ 1
16 QAM	> 5	> 4	> 8	> 12	> 16	> 18	≤ 2

For PRACH, PUCCH and SRS transmissions, the allowed MPR is according to that specified for PUSCH QPSK modulation for the corresponding transmission bandwidth.

For each subframe, the MPR is evaluated per slot and given by the maximum value taken over the transmission(s) within the slot; the maximum MPR over the two slots is then applied for the entire subframe.

For the UE maximum output power modified by MPR, the power limits specified in subclause 6.2.5 apply.

6.2.3A UE Maximum Output power for modulation / channel bandwidth for CA

For inter-band carrier aggregation with uplink assigned to one E-UTRA band (Table 5.6A-1), the requirements in subclause 6.2.3 apply.

For intra-band contiguous carrier aggregation the allowed Maximum Power Reduction (MPR) for the maximum output power in Table 6.2.2A-1 due to higher order modulation and contiguously allocated transmissions (resource blocks) is specified in Table 6.2.3A-1. In case the modulation format is different on different component carriers then the MPR is determined by the rules applied to higher order of those modulations.

Table 6.2.3A-1: Maximum Power Reduction (MPR) for Power Class 3

Modulation	CA bandwidth Class C			MPR (dB)
	50 RB + 100 RB	75 RB + 75 RB	100 RB + 100 RB	
QPSK	> 12 and ≤ 50	> 16 and ≤ 75	> 18 and ≤ 100	≤ 1
QPSK	> 50	> 75	> 100	≤ 2
16 QAM	≤ 12	≤ 16	≤ 18	≤ 1
16 QAM	> 12 and ≤ 50	> 16 and ≤ 75	> 18 and ≤ 100	≤ 2
16 QAM	> 50	> 75	> 100	≤ 3

For PUCCH and SRS transmissions, the allowed MPR is according to that specified for PUSCH QPSK modulation for the corresponding transmission bandwidth.

For intra-band contiguous carrier aggregation bandwidth class C with non-contiguous resource allocation, the allowed Maximum Power Reduction (MPR) for the maximum output power in Table 6.2.2A-1 is specified as follows

$$\text{MPR} = \text{CEIL} \{M_A, 0.5\}$$

Where M_A is defined as follows

$$M_A = \begin{array}{ll} 8.2 & ; 0 \leq A < 0.025 \\ 9.2 - 40A & ; 0.025 \leq A < 0.05 \\ 8 - 16A & ; 0.05 \leq A < 0.25 \\ 4.83 - 3.33A & ; 0.25 \leq A \leq 0.4, \\ 3.83 - 0.83A & ; 0.4 \leq A \leq 1, \end{array}$$

Where

$$A = N_{RB_alloc} / N_{RB_agg}$$

$\text{CEIL}\{M_A, 0.5\}$ means rounding upwards to closest 0.5dB, i.e. $\text{MPR} \in [3.0, 3.5, 4.0, 4.5, 5.0, 5.5, 6.0, 6.5, 7.0, 7.5, 8.0, 8.5]$

For intra-band carrier aggregation, the MPR is evaluated per slot and given by the maximum value taken over the transmission(s) on all component carriers within the slot; the maximum MPR over the two slots is then applied for the entire subframe.

For the UE maximum output power modified by MPR, the power limits specified in subclause 6.2.5A apply.

6.2.3B UE maximum output power for modulation / channel bandwidth for UL-MIMO

For UE with two transmit antenna connectors in closed-loop spatial multiplexing scheme, the allowed Maximum Power Reduction (MPR) for the maximum output power in Table 6.2.2B-1 is specified in Table 6.2.3-1. The requirements shall be met with UL-MIMO configurations defined in Table 6.2.2B-2. For UE supporting UL-MIMO, the maximum output power is measured as the sum of the maximum output power at each UE antenna connector.

For the UE maximum output power modified by MPR, the power limits specified in subclause 6.2.5B apply.

If UE is configured for transmission on single-antenna port, the requirements in subclause 6.2.3 apply.

6.2.4 UE maximum output power with additional requirements

Additional ACLR and spectrum emission requirements can be signalled by the network to indicate that the UE shall also meet additional requirements in a specific deployment scenario. To meet these additional requirements, Additional Maximum Power Reduction (A-MPR) is allowed for the output power as specified in Table 6.2.2-1. Unless stated otherwise, an A-MPR of 0 dB shall be used.

For UE Power Class 3 the specific requirements and identified subclauses are specified in Table 6.2.4-1 along with the allowed A-MPR values that may be used to meet these requirements. The allowed A-MPR values specified below in Table 6.2.4-1 to 6.2.4-6 are in addition to the allowed MPR requirements specified in subclause 6.2.3.

Table 6.2.4-1: Additional Maximum Power Reduction (A-MPR)

Network Signalling value	Requirements (subclause)	E-UTRA Band	Channel bandwidth (MHz)	Resources Blocks (N_{RB})	A-MPR (dB)
NS_01	6.6.2.1.1	Table 5.5-1	1.4, 3, 5, 10, 15, 20	Table 5.6-1	N/A
NS_03	6.6.2.2.1	2, 4, 10, 23, 25, 35, 36	3	>5	≤ 1
			5	>6	≤ 1
			10	>6	≤ 1
			15	>8	≤ 1
			20	>10	≤ 1
NS_04	6.6.2.2.2	41	5	>6	≤ 1
			10, 15, 20	Table 6.2.4-4	
NS_05	6.6.3.3.1	1	10, 15, 20	≥ 50	≤ 1
NS_06	6.6.2.2.3	12, 13, 14, 17	1.4, 3, 5, 10	Table 5.6-1	N/A
NS_07	6.6.2.2.3	13	10	Table 6.2.4-2	Table 6.2.4-2
	6.6.3.3.2				
NS_08	6.6.3.3.3	19	10, 15	> 44	≤ 3
NS_09	6.6.3.3.4	21	10, 15	> 40	≤ 1
				> 55	≤ 2
NS_10		20	15, 20	Table 6.2.4-3	Table 6.2.4-3
NS_11	6.6.2.2.1	23	1.4, 3, 5, 10, 15, 20	Table 6.2.4-5	Table 6.2.4-5
	6.6.3.3.13				
..					
NS_20	6.2.2	23	5, 10, 15, 20	Table 6.2.4-6	Table 6.2.4-6
	6.6.2.2.1				
	6.6.3.3.14				
NS_22	6.6.3.3.15	42, 43	5, 10, 15, 20	Table 6.2.4-7	
NS_23	6.6.3.3.16	42, 43	5, 10, 15, 20	N/A	
..					
NS_32	-	-	-	-	-
..					
NS_56	6.6.3.3.35	24	5, 10	Table 6.2.4-34a	

Table 6.2.4-2: A-MPR for “NS_07”

Parameters	Region A		Region B		Region C
RB_{start}	0 - 12		13 – 18	19 – 42	43 – 49
L_{CRB} [RBs]	6-8	1 to 5 and 9-50	≥ 8	≥ 18	≤ 2
A-MPR [dB]	≤ 8	≤ 12	≤ 12	≤ 6	≤ 3
NOTE 1; RB_{start} indicates the lowest RB index of transmitted resource blocks NOTE 2; L_{CRB} is the length of a contiguous resource block allocation NOTE 3; For intra-subframe frequency hopping between two regions, notes 1 and 2 apply on a per slot basis. NOTE 4; For intra-subframe frequency hopping between two regions, the larger A-MPR value of the two regions may be applied for both slots in the subframe.					

Table 6.2.4-3: A-MPR for "NS_10"

Channel bandwidth [MHz]	Parameters	Region A
15	RB _{start}	0 – 10
	LCRB [RBs]	1 -20
	A-MPR [dB]	≤ 2
20	RB _{start}	0 – 15
	LCRB [RBs]	1 -20
	A-MPR [dB]	≤ 5
NOTE 1: RB _{start} indicates the lowest RB index of transmitted resource blocks		
NOTE 2: LCRB is the length of a contiguous resource block allocation		
NOTE 3: For intra-subframe frequency hopping which intersects Region A, notes 1 and 2 apply on a per slot basis		
NOTE 4: For intra-subframe frequency hopping which intersect Region A, the larger A-MPR value may be applied for both slots in the subframe		

Table 6.2.4-4: A-MPR requirements for "NS_04" with bandwidth >5MHz

Channel bandwidth [MHz]	Parameters	Region A	Region B	Region C
10	RB _{start}	0 – 12	13 – 36	37 – 49
	RB _{start} + LCRB [RBs]	N/A	>37	N/A ³
	A-MPR [dB]	≤3dB	≤2dB	≤3dB
15	RB _{start}	0 – 18	19 – 55	56 – 74
	RB _{start} + LCRB [RBs]	N/A	>56	N/A ³
	A-MPR [dB]	≤3dB	≤2dB	≤3dB
20	RB _{start}	0 – 24	25 – 74	75 – 99
	RB _{start} + LCRB [RBs]	N/A	>75	N/A ³
	A-MPR [dB]	≤3dB	≤2dB	≤3dB
NOTE 1: RB _{start} indicates the lowest RB index of transmitted resource blocks				
NOTE 2: LCRB is the length of a contiguous resource block allocation				
NOTE 3: ³ refers to any RB allocation that starts in Region A or C is allowed the specified A-MPR				
NOTE 4: For intra-subframe frequency hopping which intersects regions, notes 1 and 2 apply on a per slot basis				
NOTE 5: For intra-subframe frequency hopping which intersects regions, the larger A-MPR value may be applied for both slots in the subframe				

Table 6.2.4-5: A-MPR for "NS_11"

Channel Bandwidth [MHz]	Parameters						
3	F _c [MHz]	<2004		≥2004			
	L _{CRB} [RBs]	1-15		>5			
	A-MPR [dB]	≤5		≤1			
5	F _c [MHz]	<2004		2004 ≤ F _c <2007		≥2007	
	L _{CRB} [RBs]	1-25		1-6 & 15-25	8-12	>6	
	A-MPR [dB]	≤7		≤4	0	≤1	
10	F _c [MHz]	2005 ≤ F _c <2015			2015		
	RB _{start}	0-49			0-49		
	L _{CRB} [RBs]	1-50			1-50		
	A-MPR [dB]	≤12			0		
15	F _c [MHz]	<2012.5					
	RB _{start}	0-4	5-21		22-56		57-74
	L _{CRB} [RBs]	≥1	7-50	0-6 & ≥50	≤25	>25	>0
	A-MPR [dB]	≤15	≤7	≤10	0	≤6	≤15
	F _c [MHz]	2012.5					
	RB _{start}	0-12	13-39		40-65		66-74
	L _{CRB} [RBs]	≥1	≥30	<30	≥ (69 – RB _{start})		≥1
	A-MPR [dB]	≤10	≤6	0	≤2		≤6.5
20	F _c [MHz]	2010					
	RB _{start}	0-12	13-29		30-68		69-99
	L _{CRB} [RBs]	≥1	10-60	1-9 & >60	1-24	≥25	≥1
	A-MPR [dB]	≤15	≤7	≤10	0	≤7	≤15

Table 6.2.4-6: A-MPR for "NS_20"

Channel Bandwidth [MHz]	Parameters							
5	Fc [MHz]	< 2007.5		2007.5 ≤ Fc < 2012.5		2012.5 ≤ Fc ≤ 2017.5		
	RB _{start}	≤24		0-3	4-6	≤24		
	LCRB [RBs]	>0		15-19	≥20	≥18	1-25	
	A-MPR [dB]	≤17		≤1	≤4	≤2	≤ 0	
10	Fc [MHz]	2005						
	RB _{start}	0-25		26-34		35-49		
	LCRB [RBs]	>0		8-15	>15	>0		
	A-MPR [dB]	≤16		≤2	≤5	≤ 6		
	Fc [MHz]	2015						
	RB _{start}	0-5			6-10			
	LCRB [RBs]	≥32			≥40			
	A-MPR [dB]	≤4			≤2			
15	Fc [MHz]	2012.5						
	RB _{start}	0-14		15-24		25-39	61-74	
	LCRB [RBs]	1-9 & 40-75	10-39	24-29	≥30	≥36	≤6	
	A-MPR [dB]	≤11	≤6	≤1	≤7	≤5	≤6	
20	Fc [MHz]	2010						
	RB _{start}	0-21	22-31		32-38	39-49	50-68	69-99
	LCRB [RBs]	>0	1-9 & 31-75	10-30	≥15	≥24	≥25	>0
	A-MPR [dB]	≤17	≤12	≤6	≤9	≤7	≤5	≤16
NOTE 1: When NS_20 is signaled the minimum requirements for the 10 MHz bandwidth are specified for E-UTRA UL carrier center frequencies of 2005 MHz or 2015 MHz.								
NOTE 2: When NS_20 is signaled the minimum requirements for the 15 MHz channel bandwidth are specified for E-UTRA UL carrier center frequency of 2012.5 MHz.								

Table 6.2.4-7: A-MPR for "NS_22"

Channel bandwidth [MHz]	Parameters	Region A	Region B	Region C	Region D
5	No A-MPR is needed for 5 MHz channel bandwidth				
10	RB _{start}	0-13	0-17	≤ 6	≥ 12
	L _{CRB} [RBs]	> 36	33-36	≤ 32	≤ 32
	RB _{start} + L _{CRB} [RBs]	N/A	N/A	N/A	≥ 44
	A-MPR [dB]	≤ 4	≤ 3	≤ 3	≤ 3
15	RB _{start}	0-24	0-38	≤ 14	≥ 23
	L _{CRB} [RBs]	> 50	37-50	≤ 36	≤ 36
	RB _{start} + L _{CRB} [RBs]	N/A	N/A	N/A	≥ 59
	A-MPR [dB]	≤ 5	≤ 4	≤ 3	≤ 3
20	RB _{start}	0-35	0-51	≤ 21	≥ 31
	L _{CRB} [RBs]	> 64	49-64	≤ 48	≤ 48
	RB _{start} + L _{CRB} [RBs]	N/A	N/A	N/A	≥ 79
	A-MPR [dB]	≤ 5	≤ 4	≤ 3	≤ 3
NOTE 1; RB _{start} indicates the lowest RB index of transmitted resource blocks					
NOTE 2; L _{CRB} is the length of a contiguous resource block allocation					
NOTE 3; For intra-subframe frequency hopping between two regions, notes 1 and 2 apply on a per slot basis.					
NOTE 4; For intra-subframe frequency hopping between two regions, the larger A-MPR value of the two regions may be applied for both slots in the subframe.					

Table 6.2.4-8: Void

Table 6.2.4-9: Void

Table 6.2.4-10: Void

Table 6.2.4-11: Void

Table 6.2.4-12: Void

Table 6.2.4-13: Void

Table 6.2.4-14: Void

Table 6.2.4-15: Void

Table 6.2.4-16: Void

Table 6.2.4-17: Void

Table 6.2.4-18: Void

Table 6.2.4-18E: Void

Table 6.2.4-19: Void

Table 6.2.4-20: Void

Table 6.2.4-21: Void

Table 6.2.4-22: Void

Table 6.2.4-23: Void

Table 6.2.4-24: Void

Table 6.2.4-25: Void

Table 6.2.4-26: Void

Table 6.2.4-27: Void

Table 6.2.4-28: Void

Table 6.2.4-29: Void

Table 6.2.4-30a: Void

Table 6.2.4-30b: Void

Table 6.2.4-31: Void

Table 6.2.4-32: Void

Table 6.2.4-32a: Void

Table 6.2.4-32b: Void

Table 6.2.4-33: Void

Table 6.2.4-34: Void

Table 6.2.4-34a: A-MPR for "NS_56"

Channel bandwidth confined to 1627.5- 1637.5MHz									
Channel bandwidth	Carrier centre frequency (Fc) (MHz)	Parameters	Region A	Region B	Region C	Region D	Region E	Region F	Region G
5 MHz	1630.0, 1630.3	RB _{start}	≤ 8	≤ 8	N/A	N/A	N/A	N/A	N/A
		LCRB [RBs]	≤ 8	> 8	N/A	N/A	N/A	N/A	N/A
		A-MPR [dB]	8	2	N/A	N/A	N/A	N/A	N/A
	1635.0	No A-MPR needed							
	1649.0								
1654.0									
10 MHz	1632.5	RB _{start}	≤ 5	≤ 18	≤ 18	≥ 35	≥ 35	≥ 40	≥ 40
		LCRB [RBs]	≤ 5	≤ 12	> 12	≤ 7	> 7	≤ 7	> 7
		A-MPR [dB]	7	5	7	4	2	5	3
	1651.5	No A-MPR needed							

For PRACH, PUCCH and SRS transmissions, the allowed A-MPR is according to that specified for PUSCH QPSK modulation for the corresponding transmission bandwidth.

For each subframe, the A-MPR is evaluated per slot and given by the maximum value taken over the transmission(s) within the slot; the maximum A-MPR over the two slots is then applied for the entire subframe.

For the UE maximum output power modified by A-MPR, the power limits specified in subclause 6.2.5 apply.

6.2.4A UE maximum output power with additional requirements for CA

Additional ACLR, spectrum emission and spurious emission requirements for carrier aggregation can be signalled by the network to indicate that the UE shall also meet additional requirements in a specific deployment scenario. To meet these additional requirements, Additional Maximum Power Reduction (A-MPR) is allowed for the CA Power Class as specified in Table 6.2.2A-1.

If for intra-band carrier aggregation the UE is configured for transmissions on a single serving cell, then subclauses 6.2.3 and 6.2.4 apply with the Network Signaling value indicated by the field *additionalSpectrumEmission*.

For intra-band contiguous aggregation with the UE configured for transmissions on two serving cells, the maximum output power reduction specified in Table 6.2.4A-1 is allowed for all serving cells of the applicable uplink CA configurations according to the CA network signalling value indicated by the field *additionalSpectrumEmissionSCell-r10*. Then clause 6.2.3A does not apply, i.e. the carrier aggregation MPR = 0 dB, unless the value indicated is CA_NS_31.

Table 6.2.4A-1: Additional Maximum Power Reduction (A-MPR) for intra-band contiguous CA

CA Network Signalling value	Requirements (subclause)	Uplink CA Configuration	A-MPR [dB] (subclause)
CA_NS_01	6.6.3.3A.1	CA_1C	6.2.4A.1
CA_NS_02	6.6.3.3A.2	CA_1C	6.2.4A.2
CA_NS_03	6.6.3.3A.3	CA_1C	6.2.4A.3
...			
CA_NS_31	NOTE 1	Table 5.6A.1-1 (NOTE 1)	N/A
CA_NS_32	Reserved		
NOTE 1: Applicable for uplink CA configurations listed in Table 5.6A.1-1 for which none of the additional requirements in subclauses 6.6.2.2A or 6.6.3.3A apply.			
NOTE 2: The index of the sequence CA_NS corresponds to the value of <i>additionalSpectrumEmissionSCell-r10</i> .			

For PUCCH and SRS transmissions, the allowed A-MPR is according to that specified for PUSCH QPSK modulation for the corresponding transmission bandwidth.

For intra-band carrier aggregation, the A-MPR is evaluated per slot and given by the maximum value taken over the transmission(s) on all component carriers within the slot; the maximum A-MPR over the two slots is then applied for the entire subframe.

For the UE maximum output power modified by A-MPR specified in table 6.2.4A-1, the power limits specified in subclause 6.2.5A apply.

6.2.4A.1 A-MPR for CA_NS_01 for CA_1C

If the UE is configured to CA_1C and it receives IE CA_NS_01 the allowed maximum output power reduction applied to transmissions on the PCC and the SCC for contiguously aggregated signals is specified in table 6.2.4A.1-1.

Table 6.2.4A.1-1: Contiguous allocation A-MPR for CA_NS_01

CA_1C: CA_NS_01	RB _{start}	LCRB [RBs]	RB _{start} + LCRB [RBs]	A-MPR for QPSK and 16-QAM [dB]
100 RB / 100 RB	0 – 23 and 176 – 199	> 0	N/A	≤ 12.0
	24 – 105	> 64	N/A	≤ 6.0
	106 – 175	N/A	> 175	≤ 5.0
75 RB / 75 RB	0 – 6 and 143 – 149	0 < LCRB ≤ 10	N/A	≤ 11.0
		> 10	N/A	≤ 6.0
	7 – 90	> 44	N/A	≤ 5.0
	91 – 142	N/A	> 142	≤ 2.0
NOTE 1: RB _{start} indicates the lowest RB index of transmitted resource blocks				
NOTE 2: LCRB is the length of a contiguous resource block allocation				
NOTE 3: For intra-subframe frequency hopping which intersects regions, notes 1 and 2 apply on a per slot basis				
NOTE 4: For intra-subframe frequency hopping which intersects regions, the larger A-MPR value may be applied for both slots in the subframe				

If the UE is configured to CA_1C and it receives IE CA_NS_01 the allowed maximum output power reduction applied to transmissions on the PCell and the SCell with non-contiguous resource allocation is defined as follows

$$A\text{-MPR} = \text{CEIL} \{M_A, 0.5\}$$

Where M_A is defined as follows

$$M_A = \begin{cases} -22.5 A + 17 & ; 0 \leq A < 0.20 \\ -11.0 A + 14.7 & ; 0.20 \leq A < 0.70 \\ -1.7 A + 8.2 & ; 0.70 \leq A \leq 1 \end{cases}$$

Where $A = N_{RB_alloc} / N_{RB_agg}$.

6.2.4A.2 A-MPR for CA_NS_02 for CA_1C

If the UE is configured to CA_1C and it receives IE CA_NS_02 the allowed maximum output power reduction applied to transmission on the PCC and the SCC for contiguously aggregated signals is specified in Table 6.2.4A.2-1.

Table 6.2.4A.2-1: Contiguous allocation A-MPR for CA_NS_02

CA_1C: CA_NS_02	RB _{end}	LCRB [RBs]	A-MPR for QPSK and 16 QAM[dB]
100 RB / 100 RB	0 - 20	> 0	≤ 4 dB
	21 - 46	> 0	≤ 3 dB
	47 - 99	> RB _{end} - 20	≤ 3 dB
	100 - 184	>75	≤ 6 dB
	185 - 199	> 0	≤ 10 dB
75 RB / 75 RB	0 - 48	> 0	≤ 2 dB
	49 - 80	> RB _{end} - 20	≤ 3 dB
	81 - 129	> 60	≤ 5 dB
	130 - 149	> 84	≤ 6 dB
	130 - 149	1-84	≤ 2 dB

If the UE is configured to CA_1C and it receives IE CA_NS_02 the allowed maximum output power reduction applied to transmissions on the PCell and the SCell with non-contiguous resource allocation is defined as follows:

$$A\text{-MPR} = \text{CEIL} \{M_A, 0.5\}$$

Where M_A is defined as follows

$$M_A = \begin{cases} -22.5 A + 17 & ; 0 \leq A < 0.20 \\ -11.0 A + 14.7 & ; 0.20 \leq A < 0.70 \\ -1.7 A + 8.2 & ; 0.70 \leq A \leq 1 \end{cases}$$

Where $A = N_{RB_alloc} / N_{RB_agg}$.

6.2.4A.3 A-MPR for CA_NS_03 for CA_1C

If the UE is configured to CA_1C and it receives IE CA_NS_03 the allowed maximum output power reduction applied to transmission on the PCC and the SCC for contiguously aggregated signals is specified in Table 6.2.4A.3-1.

Table 6.2.4A.3-1: Contiguous allocation A-MPR for CA_NS_03

CA_1C: CA_NS_03	RB _{end}	L _{CRB} [RBs]	A-MPR for QPSK and 16-QAM [dB]
100 RB / 100 RB	0 - 26	> 0	≤ 10 dB
	27 - 63	≥ RB _{end} - 27	≤ 6 dB
	27 - 63	< RB _{end} - 27	≤ 1 dB
	64 - 100	> RB _{end} - 20	≤ 4 dB
	101 - 171	> 68	≤ 7 dB
	172 - 199	> 0	≤ 10 dB
75 RB / 75 RB	0 - 20	> 0	≤ 10 dB
	21 - 45	> 0	≤ 4 dB
	46 - 75	> RB _{end} - 13	≤ 2 dB
	76 - 95	> 45	≤ 5 dB
	96 - 149	> 43	≤ 8 dB
	120 - 149	1-43	≤ 6 dB

If the UE is configured to CA_1C and it receives IE CA_NS_03 the allowed maximum output power reduction applied to transmissions on the PCell and the SCell with non-contiguous resource allocation is defined as follows:

$$A\text{-MPR} = \text{CEIL} \{M_A, 0.5\}$$

Where M_A is defined as follows

$$M_A = -23.33A + 17.5 \quad ; 0 \leq A < 0.15$$

$$-7.65A + 15.15 \quad ; 0.15 \leq A \leq 1$$

Where $A = N_{RB_alloc} / N_{RB_agg}$.

6.2.4B UE maximum output power with additional requirements for UL-MIMO

For UE with two transmit antenna connectors in closed-loop spatial multiplexing scheme, the A-MPR values specified in subclause 6.2.4 shall apply to the maximum output power specified in Table 6.2.2B-1. The requirements shall be met with the UL-MIMO configurations specified in Table 6.2.2B-2. For UE supporting UL-MIMO, the maximum output power is measured as the sum of the maximum output power at each UE antenna connector. Unless stated otherwise, an A-MPR of 0 dB shall be used.

For the UE maximum output power modified by A-MPR, the power limits specified in subclause 6.2.5B apply.

If UE is configured for transmission on single-antenna port, the requirements in subclause 6.2.4 apply.

6.2.5 Configured transmitted power

The UE is allowed to set its configured maximum output power $P_{CMAX,c}$ for serving cell c . The configured maximum output power $P_{CMAX,c}$ is set within the following bounds:

$$P_{CMAX_L,c} \leq P_{CMAX,c} \leq P_{CMAX_H,c}$$

with

$$P_{CMAX_L,c} = \text{MIN} \{P_{EMAX,c} - \Delta T_{C,c}, P_{PowerClass} - \text{MAX}(MPR_{c}, A\text{-MPR}_{c} + \Delta T_{IB,c} + \Delta T_{C,c}, P\text{-MPR}_{c})\}$$

$$P_{CMAX_H,c} = \text{MIN} \{P_{EMAX,c}, P_{PowerClass}\}$$

where

- $P_{EMAX,c}$ is the value given by IE *P-Max* for serving cell c , defined in [7];
- $P_{PowerClass}$ is the maximum UE power specified in Table 6.2.2-1 without taking into account the tolerance specified in the Table 6.2.2-1.
- MPR_c and $A-MPR_c$ for serving cell c are specified in subclause 6.2.3 and subclause 6.2.4, respectively;
- $\Delta T_{IB,c}$ is the additional tolerance for serving cell c as specified in Table 6.2.5-2; $\Delta T_{IB,c} = 0$ dB otherwise;
- $\Delta T_{C,c} = 1.5$ dB when Note 2 in Table 6.2.2-1 applies;
- $\Delta T_{C,c} = 0$ dB when Note 2 in Table 6.2.2-1 does not apply.

P-MPR_c is the allowed maximum output power reduction for

- a) ensuring compliance with applicable electromagnetic energy absorption requirements and addressing unwanted emissions / self desense requirements in case of simultaneous transmissions on multiple RAT(s) for scenarios not in scope of 3GPP RAN specifications;
- b) ensuring compliance with applicable electromagnetic energy absorption requirements in case of proximity detection is used to address such requirements that require a lower maximum output power.

The UE shall apply P-MPR_c for serving cell c only for the above cases. For UE conducted conformance testing P-MPR shall be 0 dB.

NOTE 1: P-MPR_c was introduced in the $P_{CMAX,c}$ equation such that the UE can report to the eNB the available maximum output transmit power. This information can be used by the eNB for scheduling decisions.

NOTE 2: P-MPR_c may impact the maximum uplink performance for the selected UL transmission path.

For each subframe, the $P_{CMAX,L,c}$ for serving cell c is evaluated per slot and given by the minimum value taken over the transmission(s) within the slot; the minimum $P_{CMAX,L,c}$ over the two slots is then applied for the entire subframe. $P_{PowerClass}$ shall not be exceeded by the UE during any period of time.

The measured configured maximum output power $P_{UMAX,c}$ shall be within the following bounds:

$$P_{CMAX,L,c} - \text{MAX}\{T_{L,c}, T(P_{CMAX,L,c})\} \leq P_{UMAX,c} \leq P_{CMAX,H,c} + T(P_{CMAX,H,c})$$

where the tolerance $T(P_{CMAX,c})$ for applicable values of $P_{CMAX,c}$ is specified in Table 6.2.5-1. The tolerance $T_{L,c}$ is the absolute value of the lower tolerance for the applicable operating band as specified in Table 6.2.2-1.

Table 6.2.5-1: $P_{CMAX,c}$ tolerance

$P_{CMAX,c}$ (dBm)	Tolerance $T(P_{CMAX,c})$ (dB)
$21 \leq P_{CMAX,c} \leq 23$	2.0
$20 \leq P_{CMAX,c} < 21$	2.5
$19 \leq P_{CMAX,c} < 20$	3.5
$18 \leq P_{CMAX,c} < 19$	4.0
$13 \leq P_{CMAX,c} < 18$	5.0
$8 \leq P_{CMAX,c} < 13$	6.0
$-40 \leq P_{CMAX,c} < 8$	7.0

For the UE which supports inter-band carrier aggregation configurations with the uplink assigned to one E-UTRA band the $\Delta T_{IB,c}$ is defined for applicable bands in Table 6.2.5-2.

Table 6.2.5-2: $\Delta T_{IB,c}$

Inter-band CA Configuration	E-UTRA Band	$\Delta T_{IB,c}$ [dB]
CA_1A-5A	1	0.3
	5	0.3
<p>NOTE 1: The above additional tolerances are only applicable for the E-UTRA operating bands that belong to the supported inter-band carrier aggregation configurations</p> <p>NOTE 2: The above additional tolerances also apply in non-aggregated operation for the supported E-UTRA operating bands that belong to the supported inter-band carrier aggregation configurations</p> <p>NOTE 3: In case the UE supports more than one of the above inter-band carrier aggregation configurations and a E-UTRA operating band belongs to more than one inter-band carrier aggregation configurations then:</p> <ul style="list-style-type: none"> - When the E-UTRA operating band frequency range is ≤ 1GHz, the applicable additional tolerance shall be the average of the tolerances in Table 6.2.5A-3, truncated to one decimal place for that operating band among the supported CA configurations. In case there is a harmonic relation between low band UL and high band DL, then the maximum tolerance among the different supported carrier aggregation configurations involving such band shall be applied - When the E-UTRA operating band frequency range is >1GHz, the applicable additional tolerance shall be the maximum tolerance in Table 6.2.5A-3 that applies for that operating band among the supported CA configurations 		

NOTE: The above additional tolerances do not apply to supported UTRA operating bands with frequency range below 1 GHz that correspond to the E-UTRA operating bands that belong to the supported inter-band carrier aggregation configurations when such bands are belonging only to band combination(s) where one band is <1 GHz and another band is >1.7 GHz and there is no harmonic relationship between the low band UL and high band DL. Otherwise the above additional tolerances also apply to supported UTRA operating bands that correspond to the E-UTRA operating bands that belong to the supported inter-band carrier aggregation configurations.

6.2.5A Configured transmitted power for CA

For uplink carrier aggregation the UE is allowed to set its configured maximum output power $P_{CMAX,c}$ for serving cell c and its total configured maximum output power P_{CMAX} .

The configured maximum output power $P_{CMAX,c}$ on serving cell c shall be set as specified in subclause 6.2.5.

For uplink intra-band contiguous carrier aggregation, $MPR_c = MPR$ and $A-MPR_c = A-MPR$ with MPR and $A-MPR$ specified in subclause 6.2.3A and subclause 6.2.4A respectively. There is one power management term for the UE, denoted P-MPR, and $P-MPR_c = P-MPR$. $P_{CMAX,c}$ is calculated under the assumption that the transmit power is increased by the same amount in dB on all component carriers.

The total configured maximum output power P_{CMAX} shall be set within the following bounds:

$$P_{CMAX_L} \leq P_{CMAX} \leq P_{CMAX_H}$$

For uplink intra-band contiguous carrier aggregation,

$$P_{CMAX_L} = \text{MIN}\{10 \log_{10} \sum p_{EMAX,c} - \Delta T_C, P_{PowerClass} - \text{MAX}(MPR + A-MPR + \Delta T_{IB,c} + \Delta T_C, P-MPR)\}$$

$$P_{CMAX_H} = \text{MIN}\{10 \log_{10} \sum p_{EMAX,c}, P_{PowerClass}\}$$

where

- $p_{EMAX,c}$ is the linear value of $P_{EMAX,c}$ which is given by IE *P-Max* for serving cell c in [7];
- $P_{PowerClass}$ is the maximum UE power specified in Table 6.2.2A-1 without taking into account the tolerance specified in the Table 6.2.2A-1;
- MPR and $A-MPR$ are specified in subclause 6.2.3A and subclause 6.2.4A respectively;

- $\Delta T_{IB,c}$ is the additional tolerance for serving cell c as specified in Table 6.2.5-2;
- P-MPR is the power management term for the UE;
- ΔT_C is the highest value $\Delta T_{C,c}$ among all serving cells c in the subframe over both timeslots. $\Delta T_{C,c} = 1.5$ dB when Note 2 in Table 6.2.2A-1 applies to the serving cell c , otherwise $\Delta T_{C,c} = 0$ dB.

For each subframe, the $P_{CMAX,L}$ is evaluated per slot and given by the minimum value taken over the transmission(s) within the slot; the minimum $P_{CMAX,L}$ over the two slots is then applied for the entire subframe. $P_{PowerClass}$ shall not be exceeded by the UE during any period of time.

In case PC2 and uplink intra-band contiguous CA capable UE receives $p_{EMAX,c}$ in Scell then that applies both to Scell and Pcell once the Scell is activated.

The measured maximum output power P_{UMAX} over all serving cells shall be within the following range:

$$P_{CMAX,L} - \text{MAX}\{T_L, T_{LOW}(P_{CMAX,L})\} \leq P_{UMAX} \leq P_{CMAX,H} + T_{HIGH}(P_{CMAX,H})$$

$$P_{UMAX} = 10 \log_{10} \sum p_{UMAX,c}$$

where $p_{UMAX,c}$ denotes the measured maximum output power for serving cell c expressed in linear scale. The tolerances $T_{LOW}(P_{CMAX})$ and $T_{HIGH}(P_{CMAX})$ for applicable values of P_{CMAX} are specified in Table 6.2.5A-2 for intra-band carrier aggregation. The tolerance T_L is the absolute value of the lower tolerance for applicable E-UTRA CA configurations as specified in Table 6.2.2A-1 for intra-band contiguous carrier aggregation.

Table 6.2.5A-2: P_{CMAX} tolerance for dual uplink intra-band contiguous CA

P_{CMAX} (dBm)	Tolerance $T_{LOW}(P_{CMAX})$ (dB)	Tolerance $T_{HIGH}(P_{CMAX})$ (dB)
$21 \leq P_{CMAX} \leq 23$		2.0
$20 \leq P_{CMAX} < 21$		2.5
$19 \leq P_{CMAX} < 20$		3.5
$18 \leq P_{CMAX} < 19$		4.0
$13 \leq P_{CMAX} < 18$		5.0
$8 \leq P_{CMAX} < 13$		6.0
$-40 \leq P_{CMAX} < 8$		7.0

6.2.5B Configured transmitted power for UL-MIMO

For UE supporting UL-MIMO, the transmitted power is configured per each UE.

The definitions of configured maximum output power $P_{CMAX,c}$, the lower bound $P_{CMAX,L,c}$, and the higher bound $P_{CMAX,H,c}$ specified in subclause 6.2.5 shall apply to UE supporting UL-MIMO, where

- $P_{PowerClass}$ and $\Delta T_{C,c}$ are specified in subclause 6.2.2B;
- MPR_c is specified in subclause 6.2.3B;
- $A-MPR_c$ is specified in subclause 6.2.4B.

The measured configured maximum output power $P_{UMAX,c}$ for serving cell c shall be within the following bounds:

$$P_{CMAX,L,c} - \text{MAX}\{T_L, T_{LOW}(P_{CMAX,L,c})\} \leq P_{UMAX,c} \leq P_{CMAX,H,c} + T_{HIGH}(P_{CMAX,H,c})$$

where $T_{LOW}(P_{CMAX,L,c})$ and $T_{HIGH}(P_{CMAX,H,c})$ are defined as the tolerance and applies to $P_{CMAX,L,c}$ and $P_{CMAX,H,c}$ separately, while T_L is the absolute value of the lower tolerance in Table 6.2.2B-1 for the applicable operating band.

For UE with two transmit antenna connectors in closed-loop spatial multiplexing scheme, the tolerance is specified in Table 6.2.5B-1. The requirements shall be met with UL-MIMO configurations specified in Table 6.2.2B-2.

Table 6.2.5B-1: $P_{\text{CMAX},c}$ tolerance in closed-loop spatial multiplexing scheme

$P_{\text{CMAX},c}$ (dBm)	Tolerance $T_{\text{LOW}}(P_{\text{CMAX}_L,c})$ (dB)	Tolerance $T_{\text{HIGH}}(P_{\text{CMAX}_H,c})$ (dB)
$P_{\text{CMAX},c} = 23$	3.0	2.0
$22 \leq P_{\text{CMAX},c} < 23$	5.0	2.0
$21 \leq P_{\text{CMAX},c} < 22$	5.0	3.0
$20 \leq P_{\text{CMAX},c} < 21$	6.0	4.0
$16 \leq P_{\text{CMAX},c} < 20$	5.0	
$11 \leq P_{\text{CMAX},c} < 16$	6.0	
$-40 \leq P_{\text{CMAX},c} < 11$	7.0	

If UE is configured for transmission on single-antenna port, the requirements in subclause 6.2.5 apply.

6.3 Output power dynamics

6.3.1 (Void)

6.3.2 Minimum output power

The minimum controlled output power of the UE is defined as the broadband transmit power of the UE, i.e. the power in the channel bandwidth for all transmit bandwidth configurations (resource blocks), when the power is set to a minimum value.

6.3.2.1 Minimum requirement

The minimum output power is defined as the mean power in one sub-frame (1ms). The minimum output power shall not exceed the values specified in Table 6.3.2.1-1.

Table 6.3.2.1-1: Minimum output power

	Channel bandwidth / Minimum output power / Measurement bandwidth					
	1.4 MHz	3.0 MHz	5 MHz	10 MHz	15 MHz	20 MHz
Minimum output power	-40 dBm					
Measurement bandwidth	1.08 MHz	2.7 MHz	4.5 MHz	9.0 MHz	13.5 MHz	18 MHz

6.3.2A UE Minimum output power for CA

For intra-band contiguous carrier aggregation, the minimum controlled output power of the UE is defined as the transmit power of the UE per component carrier, i.e., the power in the channel bandwidth of each component carrier for all transmit bandwidth configurations (resource blocks), when the power on both component carriers are set to a minimum value.

6.3.2A.1 Minimum requirement for CA

For intra-band contiguous carrier aggregation the minimum output power is defined as the mean power in one sub-frame (1ms). The minimum output power shall not exceed the values specified in Table 6.3.2A.1-1.

Table 6.3.2A.1-1: Minimum output power for intra-band contiguous CA UE

	CC Channel bandwidth / Minimum output power / Measurement bandwidth					
	1.4 MHz	3.0 MHz	5 MHz	10 MHz	15 MHz	20 MHz
Minimum output power	-40 dBm					
Measurement bandwidth				9.0 MHz	13.5 MHz	18 MHz

6.3.2B UE Minimum output power for UL-MIMO

For UE supporting UL-MIMO, the minimum controlled output power is defined as the broadband transmit power of the UE, i.e. the sum of the power in the channel bandwidth for all transmit bandwidth configurations (resource blocks) at each transmit antenna connector, when the UE power is set to a minimum value.

6.3.2B.1 Minimum requirement

For UE with two transmit antenna connectors in closed-loop spatial multiplexing scheme, the minimum output power is defined as the sum of the mean power at each transmit connector in one sub-frame (1ms). The minimum output power shall not exceed the values specified in Table 6.3.2B.1-1.

Table 6.3.2B.1-1: Minimum output power

	Channel bandwidth / Minimum output power / Measurement bandwidth					
	1.4 MHz	3.0 MHz	5 MHz	10 MHz	15 MHz	20 MHz
Minimum output power	-40 dBm					
Measurement bandwidth	1.08 MHz	2.7 MHz	4.5 MHz	9.0 MHz	13.5 MHz	18 MHz

If UE is configured for transmission on single-antenna port, the requirements in subclause 6.3.2 apply.

6.3.3 Transmit OFF power

Transmit OFF power is defined as the mean power when the transmitter is OFF. The transmitter is considered to be OFF when the UE is not allowed to transmit or during periods when the UE is not transmitting a sub-frame. During DTX and measurements gaps, the UE is not considered to be OFF.

6.3.3.1. Minimum requirement

The transmit OFF power is defined as the mean power in a duration of at least one sub-frame (1ms) excluding any transient periods. The transmit OFF power shall not exceed the values specified in Table 6.3.3.1-1.

Table 6.3.3.1-1: Transmit OFF power

	Channel bandwidth / Transmit OFF power / Measurement bandwidth					
	1.4 MHz	3.0 MHz	5 MHz	10 MHz	15 MHz	20 MHz
Transmit OFF power	-50 dBm					
Measurement bandwidth	1.08 MHz	2.7 MHz	4.5 MHz	9.0 MHz	13.5 MHz	18 MHz

6.3.3A UE Transmit OFF power for CA

For intra-band contiguous carrier aggregation, transmit OFF power is defined as the mean power per component carrier when the transmitter is OFF on both component carriers. The transmitter is considered to be OFF when the UE is not allowed to transmit or during periods when the UE is not transmitting a sub-frame. During measurements gaps, the UE is not considered to be OFF.

6.3.3A.1 Minimum requirement for CA

For intra-band contiguous carrier aggregation the transmit OFF power is defined as the mean power in a duration of at least one sub-frame (1ms) excluding any transient periods. The transmit OFF power shall not exceed the values specified in Table 6.3.3A.1-1.

Table 6.3.3A.1-1: Transmit OFF power for intra-band contiguous CA UE

	Channel bandwidth / Transmit OFF power / Measurement bandwidth					
	1.4 MHz	3.0 MHz	5 MHz	10 MHz	15 MHz	20 MHz
Transmit OFF power	-50 dBm					
Measurement bandwidth				9.0 MHz	13.5 MHz	18 MHz

6.3.3B UE Transmit OFF power for UL-MIMO

For UE supporting UL-MIMO, the transmit OFF power is defined as the mean power at each transmit antenna connector when the transmitter is OFF at all transmit antenna connectors. The transmitter is considered to be OFF when the UE is not allowed to transmit or during periods when the UE is not transmitting a sub-frame. During DTX and measurements gaps, the UE is not considered to be OFF.

6.3.3B.1 Minimum requirement

The transmit OFF power is defined as the mean power at each transmit antenna connector in a duration of at least one sub-frame (1ms) excluding any transient periods. The transmit OFF power at each transmit antenna connector shall not exceed the values specified in Table 6.3.3B.1-1.

Table 6.3.3B.1-1: Transmit OFF power per antenna port

	Channel bandwidth / Transmit OFF power/ Measurement bandwidth					
	1.4 MHz	3.0 MHz	5 MHz	10 MHz	15 MHz	20 MHz
Transmit OFF power	-50 dBm					
Measurement bandwidth	1.08 MHz	2.7 MHz	4.5 MHz	9.0 MHz	13.5 MHz	18 MHz

6.3.4 ON/OFF time mask

6.3.4.1 General ON/OFF time mask

The General ON/OFF time mask defines the observation period between Transmit OFF and ON power and between Transmit ON and OFF power. ON/OFF scenarios include; the beginning or end of DTX, measurement gap, contiguous, and non contiguous transmission

The OFF power measurement period is defined in a duration of at least one sub-frame excluding any transient periods. The ON power is defined as the mean power over one sub-frame excluding any transient period.

There are no additional requirements on UE transmit power beyond that which is required in subclause 6.2.2 and subclause 6.6.2.3

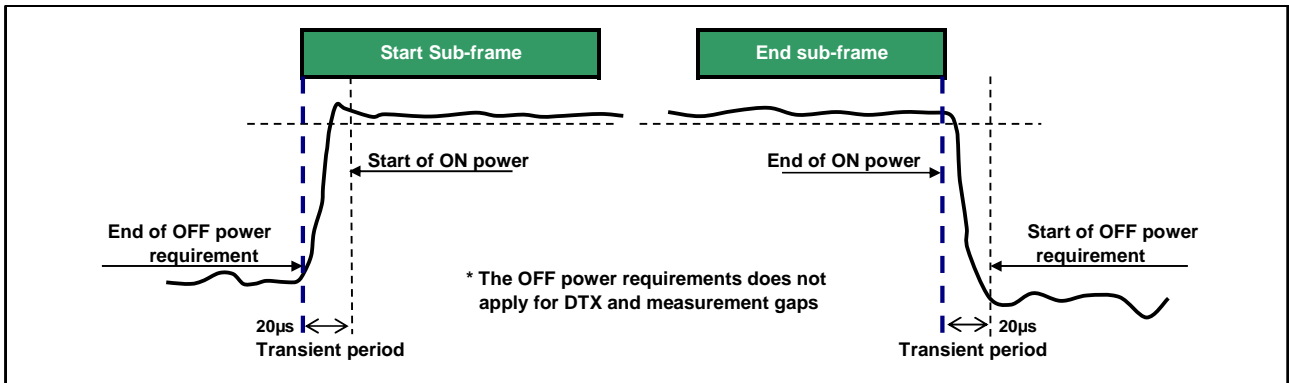

Figure 6.3.4.1-1: General ON/OFF time mask

6.3.4.2 PRACH and SRS time mask

6.3.4.2.1 PRACH time mask

The PRACH ON power is specified as the mean power over the PRACH measurement period excluding any transient periods as shown in Figure 6.3.4.2-1. The measurement period for different PRACH preamble format is specified in Table 6.3.4.2-1.

There are no additional requirements on UE transmit power beyond that which is required in subclause 6.2.2 and subclause 6.6.2.3

Table 6.3.4.2-1: PRACH ON power measurement period

PRACH preamble format	Measurement period (ms)
0	0.9031
1	1.4844
2	1.8031
3	2.2844
4	0.1479

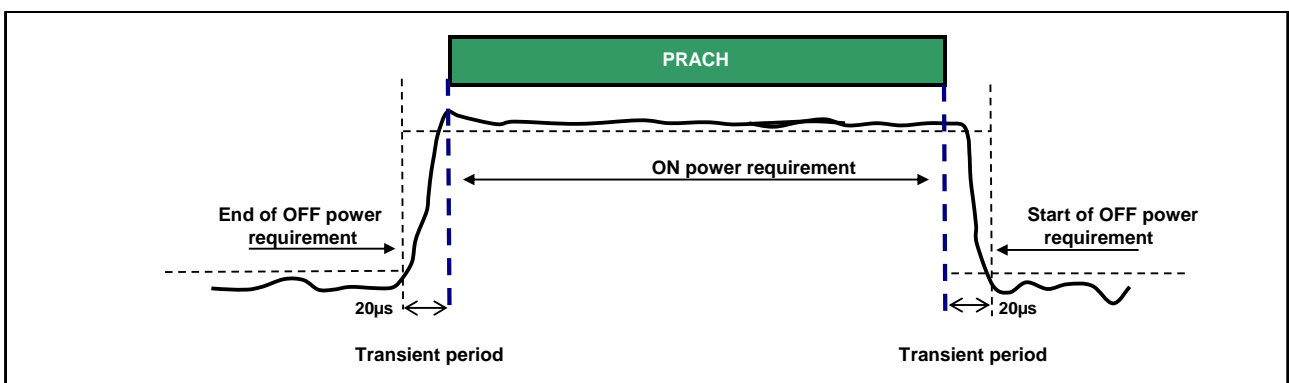

Figure 6.3.4.2-1: PRACH ON/OFF time mask

6.3.4.2.2 SRS time mask

In the case a single SRS transmission, the ON power is defined as the mean power over the symbol duration excluding any transient period. Figure 6.3.4.2.2-1

In the case a dual SRS transmission, the ON power is defined as the mean power for each symbol duration excluding any transient period. Figure 6.3.4.2.2-2

There are no additional requirements on UE transmit power beyond that which is required in subclause 6.2.2 and subclause 6.6.2.3

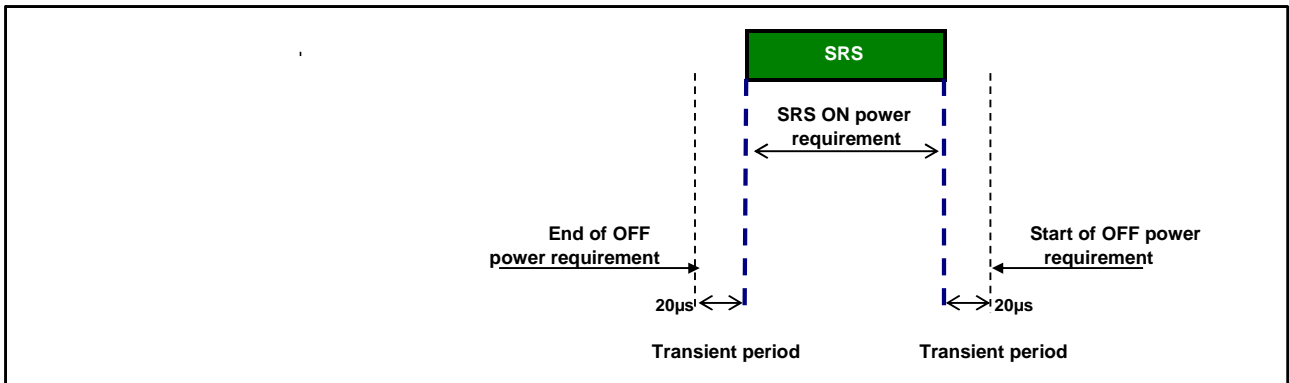

Figure 6.3.4.2.2-1: Single SRS time mask

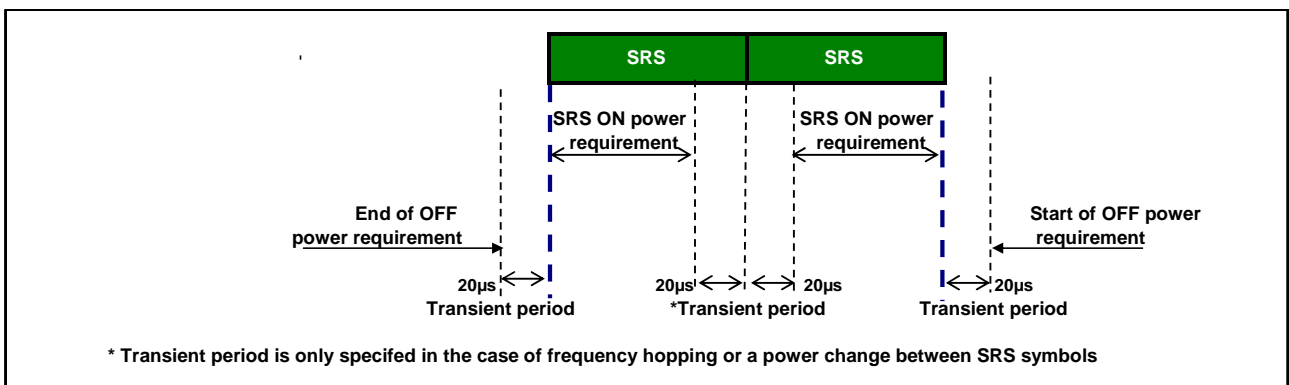

Figure 6.3.4.2.2-2: Dual SRS time mask for the case of UpPTS transmissions

6.3.4.3 Slot / Sub frame boundary time mask

The sub frame boundary time mask defines the observation period between the previous/subsequent sub-frame and the (reference) sub-frame. A transient period at a slot boundary within a sub-frame is only allowed in the case of Intra-sub frame frequency hopping. For the cases when the subframe contains SRS the time masks in subclause 6.3.4.4 apply.

There are no additional requirements on UE transmit power beyond that which is required in subclause 6.2.2 and subclause 6.6.2.3

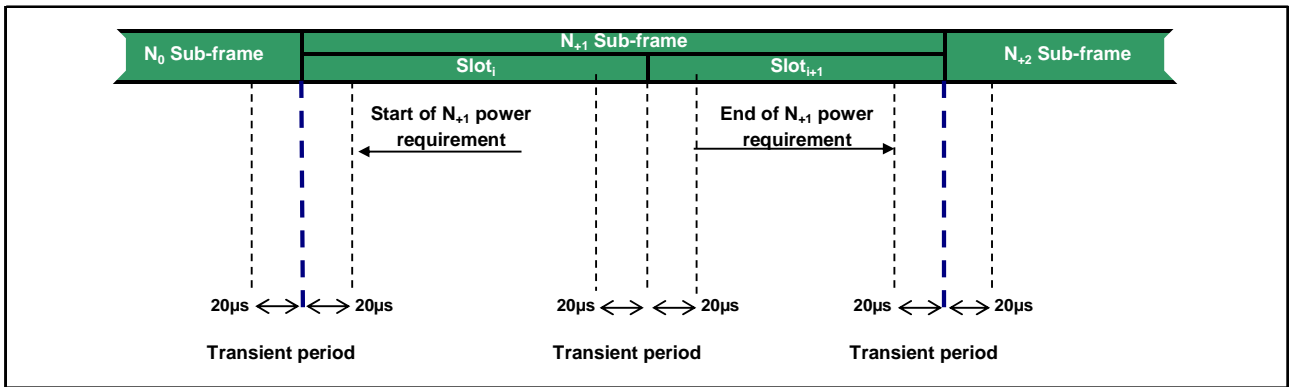

Figure 6.3.4.3-1: Transmission power template

6.3.4.4 PUCCH / PUSCH / SRS time mask

The PUCCH/PUSCH/SRS time mask defines the observation period between sounding reference symbol (SRS) and an adjacent PUSCH/PUCCH symbol and subsequent sub-frame.

There are no additional requirements on UE transmit power beyond that which is required in subclause 6.2.2 and subclause 6.6.2.3.

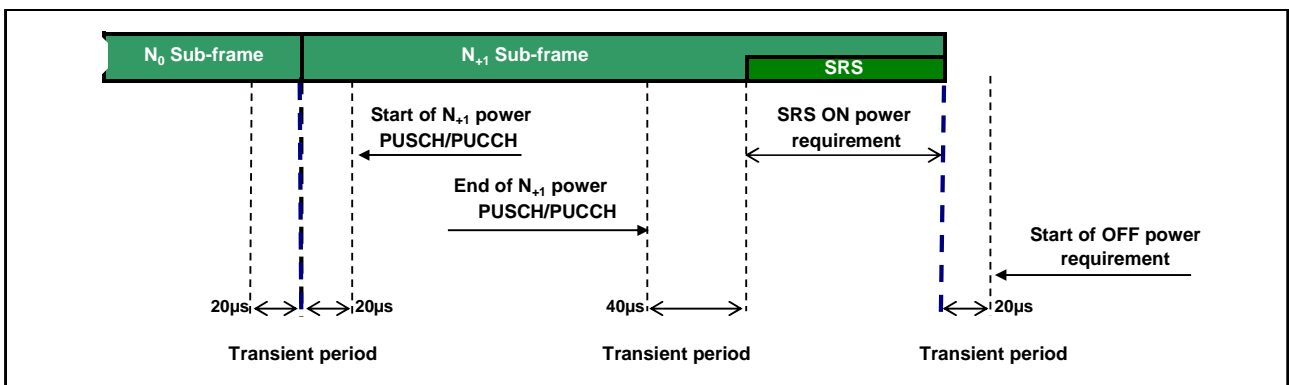

Figure 6.3.4.4-1: PUCCH/PUSCH/SRS time mask when there is a transmission before SRS but not after

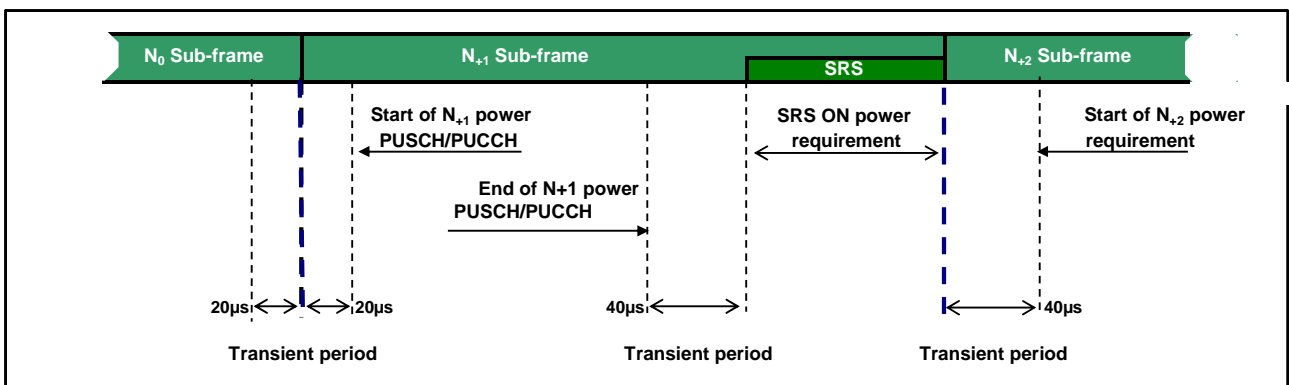

Figure 6.3.4.4-2: PUCCH/PUSCH/SRS time mask when there is transmission before and after SRS

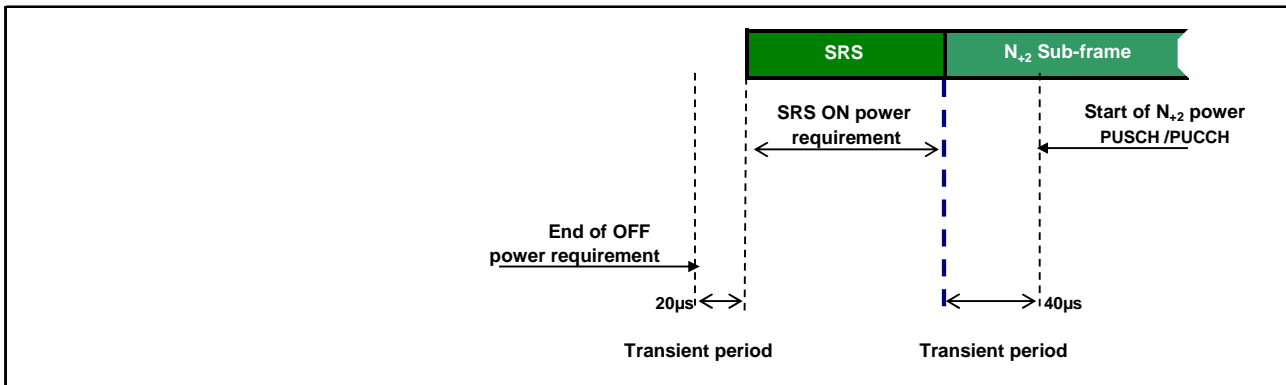

Figure 6.3.4.4-3: PUCCH/PUSCH/SRS time mask when there is a transmission after SRS but not before

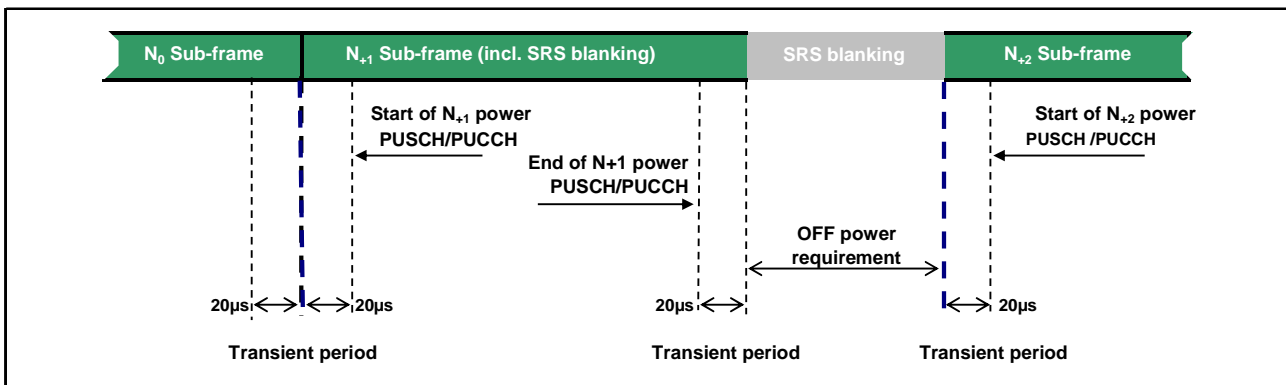

Figure 6.3.4.4-4: SRS time mask when there is FDD SRS blanking

6.3.4A ON/OFF time mask for CA

For intra-band contiguous carrier aggregation, the general output power ON/OFF time mask specified in subclause 6.3.4.1 is applicable for each component carrier during the ON power period and the transient periods. The OFF period as specified in subclause 6.3.4.1 shall only be applicable for each component carrier when all the component carriers are OFF.

6.3.4B ON/OFF time mask for UL-MIMO

For UE supporting UL-MIMO, the ON/OFF time mask requirements in subclause 6.3.4 apply at each transmit antenna connector.

For UE with two transmit antenna connectors in closed-loop spatial multiplexing scheme, the general ON/OFF time mask requirements specified in subclause 6.3.4.1 apply to each transmit antenna connector. The requirements shall be met with the UL-MIMO configurations specified in Table 6.2.2B-2.

If UE is configured for transmission on single-antenna port, the requirements in subclause 6.3.4 apply.

6.3.5 Power Control

6.3.5.1 Absolute power tolerance

Absolute power tolerance is the ability of the UE transmitter to set its initial output power to a specific value for the first sub-frame at the start of a contiguous transmission or non-contiguous transmission with a transmission gap larger than 20ms. This tolerance includes the channel estimation error (the absolute RSRP accuracy requirement specified in subclause 9.1 of TS 36.133)

In the case of a PRACH transmission, the absolute tolerance is specified for the first preamble. The absolute power tolerance includes the channel estimation error (the absolute RSRP accuracy requirement specified in subclause 9.1 of TS 36.133).

6.3.5.1.1 Minimum requirements

The minimum requirement for absolute power tolerance is given in Table 6.3.5.1.1-1 over the power range bounded by the Maximum output power as defined in subclause 6.2.2 and the Minimum output power as defined in subclause 6.3.2.

For operating bands under Note 2 in Table 6.2.2-1, the absolute power tolerance as specified in Table 6.3.5.1.1-1 is relaxed by reducing the lower limit by 1.5 dB when the transmission bandwidth is confined within F_{UL_low} and $F_{UL_low} + 4$ MHz or $F_{UL_high} - 4$ MHz and F_{UL_high} .

Table 6.3.5.1.1-1: Absolute power tolerance

Conditions	Tolerance
Normal	± 9.0 dB
Extreme	± 12.0 dB

6.3.5.2 Relative Power tolerance

The relative power tolerance is the ability of the UE transmitter to set its output power in a target sub-frame relatively to the power of the most recently transmitted reference sub-frame if the transmission gap between these sub-frames is ≤ 20 ms.

For PRACH transmission, the relative tolerance is the ability of the UE transmitter to set its output power relatively to the power of the most recently transmitted preamble. The measurement period for the PRACH preamble is specified in Table 6.3.4.2-1.

6.3.5.2.1 Minimum requirements

The requirements specified in Table 6.3.5.2.1-1 apply when the power of the target and reference sub-frames are within the power range bounded by the Minimum output power as defined in subclause 6.3.2 and the measured P_{UMAX} as defined in subclause 6.2.5 (i.e, the actual power as would be measured assuming no measurement error). This power shall be within the power limits specified in subclause 6.2.5.

To account for RF Power amplifier mode changes 2 exceptions are allowed for each of two test patterns. The test patterns are a monotonically increasing power sweep and a monotonically decreasing power sweep over a range bounded by the requirements of minimum power and maximum power specified in subclauses 6.3.2 and 6.2.2. For these exceptions the power tolerance limit is a maximum of ± 6.0 dB in Table 6.3.5.2.1-1

Table 6.3.5.2.1-1 Relative power tolerance for transmission (normal conditions)

Power step ΔP (Up or down) [dB]	All combinations of PUSCH and PUCCH transitions [dB]	All combinations of PUSCH/PUCCH and SRS transitions between sub- frames [dB]	PRACH [dB]
$\Delta P < 2$	± 2.5 (Note 3)	± 3.0	± 2.5
$2 \leq \Delta P < 3$	± 3.0	± 4.0	± 3.0
$3 \leq \Delta P < 4$	± 3.5	± 5.0	± 3.5
$4 \leq \Delta P \leq 10$	± 4.0	± 6.0	± 4.0
$10 \leq \Delta P < 15$	± 5.0	± 8.0	± 5.0
$15 \leq \Delta P$	± 6.0	± 9.0	± 6.0
NOTE 1: For extreme conditions an additional ± 2.0 dB relaxation is allowed NOTE 2: For operating bands under Note 2 in Table 6.2.2-1, the relative power tolerance is relaxed by increasing the upper limit by 1.5 dB if the transmission bandwidth of the reference sub-frames is confined within F_{UL_low} and $F_{UL_low} + 4$ MHz or $F_{UL_high} - 4$ MHz and F_{UL_high} and the target sub-frame is not confined within any one of these frequency ranges; if the transmission bandwidth of the target sub-frame is confined within F_{UL_low} and $F_{UL_low} + 4$ MHz or $F_{UL_high} - 4$ MHz and F_{UL_high} and the reference sub-frame is not confined within any one of these frequency ranges, then the tolerance is relaxed by reducing the lower limit by 1.5 dB. NOTE 3: For PUSCH to PUSCH transitions with the allocated resource blocks fixed in frequency and no transmission gaps other than those generated by downlink subframes, DwPTS fields or Guard Periods for TDD: for a power step $\Delta P \leq 1$ dB, the relative power tolerance for transmission is ± 1.0 dB.			

The power step (ΔP) is defined as the difference in the calculated setting of the UE Transmit power between the target and reference sub-frames with the power setting according to subclause 5.1 of [TS 36.213]. The error is the difference between ΔP and the power change measured at the UE antenna port with the power of the cell-specific reference signals kept constant. The error shall be less than the relative power tolerance specified in Table 6.3.5.2.1-1.

For sub-frames not containing an SRS symbol, the power change is defined as the relative power difference between the mean power of the original reference sub-frame and the mean power of the target subframe not including transient durations. The mean power of successive sub-frames shall be calculated according to Figure 6.3.4.3-1 and Figure 6.3.4.1-1 if there is a transmission gap between the reference and target sub-frames.

If at least one of the sub-frames contains an SRS symbol, the power change is defined as the relative power difference between the mean power of the last transmission within the reference sub-frame and the mean power of the first transmission within the target sub-frame not including transient durations. A transmission is defined as PUSCH, PUCCH or an SRS symbol. The mean power of the reference and target sub-frames shall be calculated according to Figures 6.3.4.1-1, 6.3.4.2-1, 6.3.4.4-1, 6.3.4.4-2 and 6.3.4.4-3 for these cases.

6.3.5.3 Aggregate power control tolerance

Aggregate power control tolerance is the ability of a UE to maintain its power in non-contiguous transmission within 21 ms in response to 0 dB TPC commands with respect to the first UE transmission, when the power control parameters specified in TS 36.213 are constant.

6.3.5.3.1 Minimum requirement

The UE shall meet the requirements specified in Table 6.3.5.3.1-1 for aggregate power control over the power range bounded by the minimum output power as defined in subclause 6.3.2 and the maximum output power as defined in subclause 6.2.2.

Table 6.3.5.3.1-1: Aggregate power control tolerance

TPC command	UL channel	Aggregate power tolerance within 21 ms
0 dB	PUCCH	± 2.5 dB
0 dB	PUSCH	± 3.5 dB
NOTE: The UE transmission gap is 4 ms. TPC command is transmitted via PDCCH 4 subframes preceding each PUCCH/PUSCH transmission.		

6.3.5A Power control for CA

The requirements apply for one single PUCCH, PUSCH or SRS transmission of contiguous PRB allocation per component carrier with power setting in accordance with Clause 5.1 of [6].

6.3.5A.1 Absolute power tolerance

The absolute power tolerance is the ability of the UE transmitter to set its initial output power to a specific value for the first sub-frame at the start of a contiguous transmission or non-contiguous transmission with a transmission gap on each active component carriers larger than 20ms. The requirement can be tested by time aligning any transmission gaps on the component carriers.

6.3.5A.1.1 Minimum requirements

For intra-band contiguous carrier aggregation bandwidth class C the absolute power control tolerance per component carrier is given in Table 6.3.5.1.1-1.

6.3.5A.2 Relative power tolerance

6.3.5A.2.1 Minimum requirements

The requirements apply when the power of the target and reference sub-frames on each component carrier exceed -20 dBm and the total power is limited by P_{UMAX} as defined in subclause 6.2.5A. For the purpose of these requirements, the power in each component carrier is specified over only the transmitted resource blocks.

For intra-band contiguous carrier aggregation bandwidth class C, the UE shall meet the following requirements for transmission on both assigned component carriers when the average transmit power per PRB is aligned across both assigned carriers in the reference sub-frame:

- for all possible combinations of PUSCH and PUCCH transitions per component carrier, the corresponding requirements given in Table 6.3.5.2.1-1;
- for SRS transitions on each component carrier, the requirements for combinations of PUSCH/PUCCH and SRS transitions given in Table 6.3.5.2.1-1 with simultaneous SRS of constant SRS bandwidth allocated in the target and reference subframes;
- for RACH on the primary component carrier, the requirements given in Table 6.3.5.2.1-1 for PRACH.

For a) and b) above, the power step ΔP between the reference and target subframes shall be set by a TPC command and/or an uplink scheduling grant transmitted by means of an appropriate DCI Format.

For a), b) and c) above, two exceptions are allowed for each component carrier for a power per carrier ranging from -20 dBm to $P_{UMAX,c}$ as defined in subclause 6.2.5. For these exceptions the power tolerance limit is ± 6.0 dB in Table 6.3.5.2.1-1.

6.3.5A.3 Aggregate power control tolerance

Aggregate power control tolerance is the ability of a UE to maintain its power in non-contiguous transmission within 21 ms in response to 0 dB TPC commands with respect to the first UE transmission, when the power control parameters specified in [6] are constant on all active component carriers.

6.3.5A.3.1 Minimum requirements

For intra-band contiguous carrier aggregation bandwidth class C, the aggregate power tolerance per component carrier is given in Table 6.3.5.3.1-1 with either simultaneous PUSCH or simultaneous PUCCH- PUSCH (if supported by the UE) configured. The average power per PRB shall be aligned across both assigned carriers before the start of the test. The requirement can be tested with the transmission gaps time aligned between component carriers.

6.3.5B Power control for UL-MIMO

For UE supporting UL-MIMO, the power control tolerance applies to the sum of output power at each transmit antenna connector.

The power control requirements specified in subclause 6.3.5 apply to UE with two transmit antenna connectors in closed-loop spatial multiplexing scheme. The requirements shall be met with UL-MIMO configurations specified in Table 6.2.2B-2, wherein

- The Maximum output power requirements for UL-MIMO are specified in subclause 6.2.2B
- The Minimum output power requirements for UL-MIMO are specified in subclause 6.3.2B
- The requirements for configured transmitted power for UL-MIMO are specified in subclause 6.2.5B.

If UE is configured for transmission on single-antenna port, the requirements in subclause 6.3.5 apply.

6.4 Void

6.5 Transmit signal quality

6.5.1 Frequency error

The UE modulated carrier frequency shall be accurate to within ± 0.1 PPM observed over a period of one time slot (0.5 ms) compared to the carrier frequency received from the E-UTRA Node B

6.5.1A Frequency error for CA

For intra-band contiguous carrier aggregation the UE modulated carrier frequencies per band shall be accurate to within ± 0.1 PPM observed over a period of one timeslot compared to the carrier frequency of primary component carrier received from the E-UTRA in the corresponding band.

6.5.1B Frequency error for UL-MIMO

For UE(s) supporting UL-MIMO, the UE modulated carrier frequency at each transmit antenna connector shall be accurate to within ± 0.1 PPM observed over a period of one time slot (0.5 ms) compared to the carrier frequency received from the E-UTRA Node B.

6.5.2 Transmit modulation quality

Transmit modulation quality defines the modulation quality for expected in-channel RF transmissions from the UE. The transmit modulation quality is specified in terms of:

- Error Vector Magnitude (EVM) for the allocated resource blocks (RBs)
- EVM equalizer spectrum flatness derived from the equalizer coefficients generated by the EVM measurement process
- Carrier leakage
- In-band emissions for the non-allocated RB

All the parameters defined in subclause 6.5.2 are defined using the measurement methodology specified in Annex F.

6.5.2.1 Error Vector Magnitude

The Error Vector Magnitude is a measure of the difference between the reference waveform and the measured waveform. This difference is called the error vector. Before calculating the EVM the measured waveform is corrected by the sample timing offset and RF frequency offset. Then the carrier leakage shall be removed from the measured waveform before calculating the EVM.

The measured waveform is further modified by selecting the absolute phase and absolute amplitude of the Tx chain. The EVM result is defined after the front-end IDFT as the square root of the ratio of the mean error vector power to the mean reference power expressed as a %.

The basic EVM measurement interval in the time domain is one preamble sequence for the PRACH and is one slot for the PUCCH and PUSCH in the time domain.. When the PUSCH or PUCCH transmission slot is shortened due to multiplexing with SRS, the EVM measurement interval is reduced by one symbol, accordingly. The PUSCH or PUCCH EVM measurement interval is also reduced when the mean power, modulation or allocation between slots is expected to change. In the case of PUSCH transmission, the measurement interval is reduced by a time interval equal to the sum of 5 μ s and the applicable exclusion period defined in subclause 6.3.4, adjacent to the boundary where the power change is expected to occur. The PUSCH exclusion period is applied to the signal obtained after the front-end IDFT. In the case of PUCCH transmission with power change, the PUCCH EVM measurement interval is reduced by one symbol adjacent to the boundary where the power change is expected to occur.

6.5.2.1.1 Minimum requirement

The RMS average of the basic EVM measurements for 10 sub-frames excluding any transient period for the average EVM case, and 60 sub-frames excluding any transient period for the reference signal EVM case, for the different modulations schemes shall not exceed the values specified in Table 6.5.2.1.1-1 for the parameters defined in Table 6.5.2.1.1-2. For EVM evaluation purposes, [all PRACH preamble formats 0-4 and] all PUCCH formats 1, 1a, 1b, 2, 2a and 2b are considered to have the same EVM requirement as QPSK modulated.

Table 6.5.2.1.1-1: Minimum requirements for Error Vector Magnitude

Parameter	Unit	Average EVM Level	Reference Signal EVM Level
QPSK or BPSK	%	17.5	17.5
16QAM	%	12.5	12.5

Table 6.5.2.1.1-2: Parameters for Error Vector Magnitude

Parameter	Unit	Level
UE Output Power	dBm	≥ -40
Operating conditions		Normal conditions

6.5.2.2 Carrier leakage

Carrier leakage is an additive sinusoid waveform that has the same frequency as a modulated waveform carrier frequency. The measurement interval is one slot in the time domain.

6.5.2.2.1 Minimum requirements

The relative carrier leakage power is a power ratio of the additive sinusoid waveform and the modulated waveform. The relative carrier leakage power shall not exceed the values specified in Table 6.5.2.2.1-1.

Table 6.5.2.2.1-1: Minimum requirements for relative carrier leakage power

Parameters	Relative limit (dBc)
Output power >0 dBm	-25
-30 dBm \leq Output power ≤ 0 dBm	-20

-40 dBm ≤ Output power < -30 dBm	-10
----------------------------------	-----

6.5.2.3 In-band emissions

The in-band emission is defined as the average across 12 sub-carrier and as a function of the RB offset from the edge of the allocated UL transmission bandwidth. The in-band emission is measured as the ratio of the UE output power in a non-allocated RB to the UE output power in an allocated RB.

The basic in-band emissions measurement interval is defined over one slot in the time domain. When the PUSCH or PUCCH transmission slot is shortened due to multiplexing with SRS, the in-band emissions measurement interval is reduced by one SC-FDMA symbol, accordingly.

6.5.2.3.1 Minimum requirements

The relative in-band emission shall not exceed the values specified in Table 6.5.2.3.1-1.

Table 6.5.2.3.1-1: Minimum requirements for in-band emissions

Parameter description	Unit	Limit (Note 1)		Applicable Frequencies
General	dB	$\max \left\{ -25 - 10 \cdot \log_{10} (N_{RB} / L_{CRB}), \right.$ $20 \cdot \log_{10} EVM - 3 - 5 \cdot (\Delta_{RB} - 1) / L_{CRB},$ $\left. -57 \text{ dBm} / 180 \text{ kHz} - P_{RB} \right\}$		Any non-allocated (Note 2)
IQ Image	dB	-25		Image frequencies (Notes 2, 3)
Carrier leakage	dBc	-25	Output power > 0 dBm	Carrier frequency (Notes 4, 5)
		-20	-30 dBm ≤ Output power ≤ 0 dBm	
		-10	-40 dBm ≤ Output power < -30 dBm	
<p>NOTE 1: An in-band emissions combined limit is evaluated in each non-allocated RB. For each such RB, the minimum requirement is calculated as the higher of $P_{RB} - 30$ dB and the power sum of all limit values (General, IQ Image or Carrier leakage) that apply. P_{RB} is defined in Note 10.</p> <p>NOTE 2: The measurement bandwidth is 1 RB and the limit is expressed as a ratio of measured power in one non-allocated RB to the measured average power per allocated RB, where the averaging is done across all allocated RBs.</p> <p>NOTE 3: The applicable frequencies for this limit are those that are enclosed in the reflection of the allocated bandwidth, based on symmetry with respect to the centre carrier frequency, but excluding any allocated RBs.</p> <p>NOTE 4: The measurement bandwidth is 1 RB and the limit is expressed as a ratio of measured power in one non-allocated RB to the measured total power in all allocated RBs.</p> <p>NOTE 5: The applicable frequencies for this limit are those that are enclosed in the RBs containing the DC frequency if N_{RB} is odd, or in the two RBs immediately adjacent to the DC frequency if N_{RB} is even, but excluding any allocated RB.</p> <p>NOTE 6: L_{CRB} is the Transmission Bandwidth (see Figure 5.6-1).</p> <p>NOTE 7: N_{RB} is the Transmission Bandwidth Configuration (see Figure 5.6-1).</p> <p>NOTE 8: EVM is the limit specified in Table 6.5.2.1.1-1 for the modulation format used in the allocated RBs.</p> <p>NOTE 9: Δ_{RB} is the starting frequency offset between the allocated RB and the measured non-allocated RB (e.g. $\Delta_{RB} = 1$ or $\Delta_{RB} = -1$ for the first adjacent RB outside of the allocated bandwidth).</p> <p>NOTE 10: P_{RB} is the transmitted power per 180 kHz in allocated RBs, measured in dBm.</p>				

6.5.2.4 EVM equalizer spectrum flatness

The zero-forcing equalizer correction applied in the EVM measurement process (as described in Annex F) must meet a spectral flatness requirement for the EVM measurement to be valid. The EVM equalizer spectrum flatness is defined in terms of the maximum peak-to-peak ripple of the equalizer coefficients (dB) across the allocated uplink block. The basic measurement interval is the same as for EVM.

6.5.2.4.1 Minimum requirements

The peak-to-peak variation of the EVM equalizer coefficients contained within the frequency range of the uplink allocation shall not exceed the maximum ripple specified in Table 6.5.2.4.1-1 for normal conditions. For uplink allocations contained within both Range 1 and Range 2, the coefficients evaluated within each of these frequency ranges shall meet the corresponding ripple requirement and the following additional requirement: the relative difference between the maximum coefficient in Range 1 and the minimum coefficient in Range 2 must not be larger than 5 dB, and the relative difference between the maximum coefficient in Range 2 and the minimum coefficient in Range 1 must not be larger than 7 dB (see Figure 6.5.2.4.1-1).

The EVM equalizer spectral flatness shall not exceed the values specified in Table 6.5.2.4.1-2 for extreme conditions. For uplink allocations contained within both Range 1 and Range 2, the coefficients evaluated within each of these frequency ranges shall meet the corresponding ripple requirement and the following additional requirement: the relative difference between the maximum coefficient in Range 1 and the minimum coefficient in Range 2 must not be larger than 6 dB, and the relative difference between the maximum coefficient in Range 2 and the minimum coefficient in Range 1 must not be larger than 10 dB (see Figure 6.5.2.4.1-1).

Table 6.5.2.4.1-1: Minimum requirements for EVM equalizer spectrum flatness (normal conditions)

Frequency range	Maximum ripple [dB]
$F_{UL_Meas} - F_{UL_Low} \geq 3 \text{ MHz}$ and $F_{UL_High} - F_{UL_Meas} \geq 3 \text{ MHz}$ (Range 1)	4 (p-p)
$F_{UL_Meas} - F_{UL_Low} < 3 \text{ MHz}$ or $F_{UL_High} - F_{UL_Meas} < 3 \text{ MHz}$ (Range 2)	8 (p-p)
NOTE 1: F_{UL_Meas} refers to the sub-carrier frequency for which the equalizer coefficient is evaluated	
NOTE 2: F_{UL_Low} and F_{UL_High} refer to each E-UTRA frequency band specified in Table 5.5-1	

Table 6.5.2.4.1-2: Minimum requirements for EVM equalizer spectrum flatness (extreme conditions)

Frequency range	Maximum Ripple [dB]
$F_{UL_Meas} - F_{UL_Low} \geq 5 \text{ MHz}$ and $F_{UL_High} - F_{UL_Meas} \geq 5 \text{ MHz}$ (Range 1)	4 (p-p)
$F_{UL_Meas} - F_{UL_Low} < 5 \text{ MHz}$ or $F_{UL_High} - F_{UL_Meas} < 5 \text{ MHz}$ (Range 2)	12 (p-p)
NOTE 1: F_{UL_Meas} refers to the sub-carrier frequency for which the equalizer coefficient is evaluated	
NOTE 2: F_{UL_Low} and F_{UL_High} refer to each E-UTRA frequency band specified in Table 5.5-1	

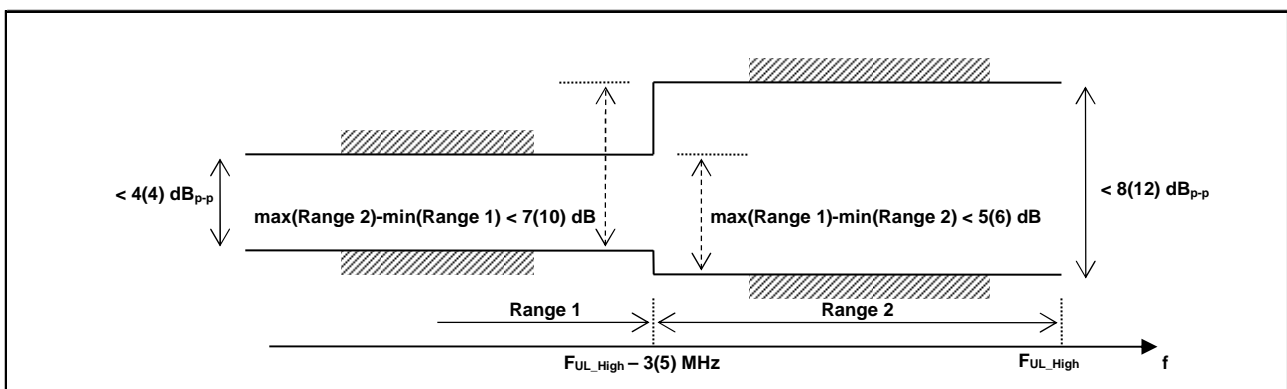

Figure 6.5.2.4.1-1: The limits for EVM equalizer spectral flatness with the maximum allowed variation of the coefficients indicated (the ETC minimum requirement within brackets).

6.5.2A Transmit modulation quality for CA

The requirements in this clause apply with PCC and SCC in the UL configured and activated: PCC with PRB allocation and SCC without PRB allocation and without CSI reporting and SRS configured.

6.5.2A.1 Error Vector Magnitude

For the intra-band contiguous carrier aggregation, the Error Vector Magnitude requirement should be defined for each component carrier. Requirements only apply with PRB allocation in one of the component carriers. Similar transmitter impairment removal procedures are applied for CA waveform before EVM calculation as is specified for non-CA waveform in sub-section 6.5.2.1.

When a single component carrier is configured Table 6.5.2.1.1-1 apply.

The EVM requirements are according to Table 6.5.2A.1-1 if CA is configured in uplink.

Table 6.5.2A.1-1: Minimum requirements for Error Vector Magnitude

Parameter	Unit	Average EVM Level per CC	Reference Signal EVM Level
QPSK or BPSK	%	17.5	17.5
16QAM	%	12.5	12.5

6.5.2A.2 Carrier leakage for CA

Carrier leakage is an additive sinusoid waveform that is confined within the aggregated transmission bandwidth configuration. The carrier leakage requirement is defined for each component carrier and is measured on the component carrier with PRBs allocated. The measurement interval is one slot in the time domain.

6.5.2A.2.1 Minimum requirements

The relative carrier leakage power is a power ratio of the additive sinusoid waveform and the modulated waveform. The relative carrier leakage power shall not exceed the values specified in Table 6.5.2A.2.1-1.

Table 6.5.2A.2.1-1: Minimum requirements for Relative Carrier Leakage Power

Parameters	Relative Limit (dBc)
Output power >0 dBm	-25
-30 dBm ≤ Output power ≤ 0 dBm	-20
-40 dBm ≤ Output power < -30 dBm	-10

6.5.2A.3 In-band emissions

6.5.2A.3.1 Minimum requirement for CA

For intra-band contiguous carrier aggregation bandwidth class C, the requirements in Table 6.5.2A.3.1-1 and 6.5.2A.3.1-2 apply within the aggregated transmission bandwidth configuration with both component carrier (s) active and one single contiguous PRB allocation of bandwidth L_{CRB} at the edge of the aggregated transmission bandwidth configuration.

The inband emission is defined as the interference falling into the non allocated resource blocks for all component carriers. The measurement method for the inband emissions in the component carrier with PRB allocation is specified in annex F. For a non allocated component carrier a spectral measurement is specified.

Table 6.5.2A.3.1-1: Minimum requirements for in-band emissions (allocated component carrier)

Parameter	Unit	Limit		Applicable Frequencies
General	dB	$\max \left\{ -25 - 10 \cdot \log_{10} (N_{RB} / L_{CRB}), \right.$ $20 \cdot \log_{10} EVM - 3 - 5 \cdot (\Delta_{RB} - 1) / L_{CRB},$ $\left. -57 \text{ dBm} / 180 \text{ kHz} - P_{RB} \right\}$		Any non-allocated (Note 2)
IQ Image	dB	-25		Exception for IQ image (Note 3)
Carrier leakage	dBc	-25	Output power > 0 dBm	Exception for Carrier frequency (Note 4)
		-20	-30 dBm ≤ Output power ≤ 0 dBm	
		-10	-40 dBm ≤ Output power < -30 dBm	
<p>NOTE 1: An in-band emissions combined limit is evaluated in each non-allocated RB. For each such RB, the minimum requirement is calculated as the higher of $P_{RB} - 30$ dB and the power sum of all limit values (General, IQ Image or Carrier leakage) that apply. P_{RB} is defined in Note 9. The limit is evaluated in each non-allocated RB.</p> <p>NOTE 2: The measurement bandwidth is 1 RB and the limit is expressed as a ratio of measured power in one non-allocated RB to the measured average power per allocated RB, where the averaging is done across all allocated RBs.</p> <p>NOTE 3: Exceptions to the general limit are allowed for up to $L_{CRB} + 1$ RBs within a contiguous width of $L_{CRB} + 1$ non-allocated RBs. The measurement bandwidth is 1 RB.</p> <p>NOTE 4: Exceptions to the general limit are allowed for up to two contiguous non-allocated RBs. The measurement bandwidth is 1 RB and the limit is expressed as a ratio of measured power in the non-allocated RB to the measured total power in all allocated RBs.</p> <p>NOTE 5: L_{CRB} is the Transmission Bandwidth (see Figure 5.6-1) not exceeding $\lfloor N_{RB} / 2 - 1 \rfloor$</p> <p>NOTE 6: N_{RB} is the Transmission Bandwidth Configuration (see Figure 5.6-1) of the component carrier with RBs allocated.</p> <p>NOTE 7: EVM is the limit specified in Table 6.5.2.1.1-1 for the modulation format used in the allocated RBs.</p> <p>NOTE 8: Δ_{RB} is the starting frequency offset between the allocated RB and the measured non-allocated RB (e.g. $\Delta_{RB} = 1$ or $\Delta_{RB} = -1$ for the first adjacent RB outside of the allocated bandwidth).</p> <p>NOTE 9: P_{RB} is the transmitted power per 180 kHz in allocated RBs, measured in dBm.</p>				

Table 6.5.2A.3.1-2: Minimum requirements for in-band emissions (non-allocated component carrier)

Parameter	Unit	Meas BW Note 1	Limit	remark	Applicable Frequencies	
General	dB	BW of 1 RB (180KHz rectangular)	$\max \left\{ -25 - 10 \cdot \log_{10} (N_{RB} / L_{CRB}), \right.$ $20 \cdot \log_{10} EVM - 3 - 5 \cdot (\Delta_{RB} - 1) / L_{CRB}$ $\left. - 57 \text{ dBm} / 180 \text{ kHz} - P_{RB} \right\}$	The reference value is the average power per allocated RB in the allocated component carrier	Any RB in the non allocated component carrier. The frequency raster of the RBs is derived when this component carrier is allocated with RBs	
IQ Image	dB	BW of 1 RB (180KHz rectangular)	-25 Note 2	The reference value is the average power per allocated RB in the allocated component carrier	The frequencies of the L_{CRB} contiguous non-allocated RBs are unknown. The frequency raster of the RBs is derived when this component carrier is allocated with RBs	
Carrier leakage	dBc	BW of 1 RB (180KHz rectangular)	Note 3		The reference value is the total power of the allocated RBs in the allocated component carrier	The frequencies of the up to 2 non-allocated RBs are unknown. The frequency raster of the RBs is derived when this component carrier is allocated with RBs
			-25	Output power > 0 dBm		
			-20	-30 dBm ≤ Output power ≤ 0 dBm		
			-10	-40 dBm ≤ Output power < -30 dBm		
NOTE1: Resolution BWs smaller than the measurement BW may be integrated to achieve the measurement bandwidth.						
NOTE 2: Exceptions to the general limit are allowed for up to $L_{CRB} + 1$ RBs within a contiguous width of $L_{CRB} + 1$ non-allocated RBs.						
NOTE 3: Exceptions to the general limit are allowed for up to two contiguous non-allocated RBs						
NOTE 4: Notes 1, 5, 6, 7, 8, 9 from Table 6.5.2A.3.1-1 apply for Table 6.5.2A.3.1-2 as well.						
NOTE 5: Δ_{RB} for measured non-allocated RB in the non allocated component carrier may take non-integer values when the carrier spacing between the CCs is not a multiple of RB.						

6.5.2B Transmit modulation quality for UL-MIMO

For UE supporting UL-MIMO, the transmit modulation quality requirements are specified at each transmit antenna connector.

If UE is configured for transmission on single-antenna port, the requirements in subclause 6.5.2 apply.

The transmit modulation quality is specified in terms of:

- Error Vector Magnitude (EVM) for the allocated resource blocks (RBs)

- EVM equalizer spectrum flatness derived from the equalizer coefficients generated by the EVM measurement process
- Carrier leakage (caused by IQ offset)
- In-band emissions for the non-allocated RB

6.5.2B.1 Error Vector Magnitude

For UE with two transmit antenna connectors in closed-loop spatial multiplexing scheme, the Error Vector Magnitude requirements specified in Table 6.5.2.1.1-1 which is defined in subclause 6.5.2.1 apply at each transmit antenna connector. The requirements shall be met with the UL-MIMO configurations specified in Table 6.2.2B-2.

6.5.2B.2 Carrier leakage

For UE with two transmit antenna connectors in closed-loop spatial multiplexing scheme, the Relative Carrier Leakage Power requirements specified in Table 6.5.2.2.1-1 which is defined in subclause 6.5.2.2 apply at each transmit antenna connector. The requirements shall be met with the UL-MIMO configurations specified in Table 6.2.2B-2.

6.5.2B.3 In-band emissions

For UE with two transmit antenna connectors in closed-loop spatial multiplexing scheme, the In-band Emission requirements specified in Table 6.5.2.3.1-1 which is defined in subclause 6.5.2.3 apply at each transmit antenna connector. The requirements shall be met with the uplink MIMO configurations specified in Table 6.2.2B-2.

6.5.2B.4 EVM equalizer spectrum flatness for UL-MIMO

For UE with two transmit antenna connectors in closed-loop spatial multiplexing scheme, the EVM Equalizer Spectrum Flatness requirements specified in Table 6.5.2.4.1-1 and Table 6.5.2.4.1-2 which are defined in subclause 6.5.2.4 apply at each transmit antenna connector. The requirements shall be met with the UL-MIMO configurations specified in Table 6.2.2B-2.

6.6 Output RF spectrum emissions

The output UE transmitter spectrum consists of the three components; the emission within the occupied bandwidth (channel bandwidth), the Out Of Band (OOB) emissions and the far out spurious emission domain.

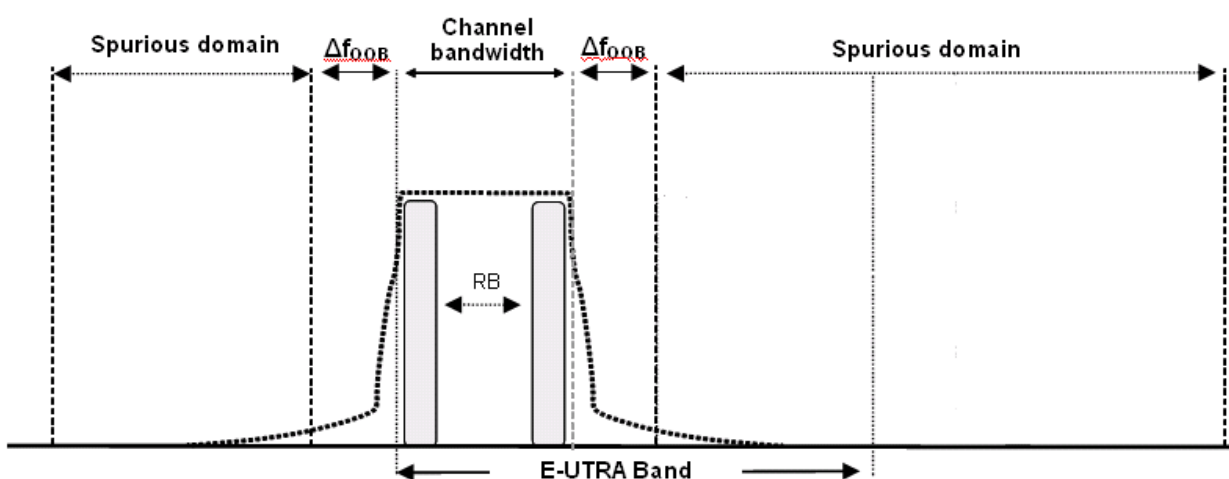

Figure 6.6-1: Transmitter RF spectrum

6.6.1 Occupied bandwidth

Occupied bandwidth is defined as the bandwidth containing 99 % of the total integrated mean power of the transmitted spectrum on the assigned channel. The occupied bandwidth for all transmission bandwidth configurations (Resources Blocks) shall be less than the channel bandwidth specified in Table 6.6.1-1

Table 6.6.1-1: Occupied channel bandwidth

	Occupied channel bandwidth / Channel bandwidth					
	1.4 MHz	3.0 MHz	5 MHz	10 MHz	15 MHz	20 MHz
Channel bandwidth (MHz)	1.4	3	5	10	15	20

6.6.1A Occupied bandwidth for CA

For intra-band contiguous carrier aggregation the occupied bandwidth is a measure of the bandwidth containing 99 % of the total integrated power of the transmitted spectrum. The OBW shall be less than the aggregated channel bandwidth defined in subclause 5.6A.

6.6.1B Occupied bandwidth for UL-MIMO

For UE supporting UL-MIMO, the requirements for occupied bandwidth is specified at each transmit antenna connector. The occupied bandwidth is defined as the bandwidth containing 99 % of the total integrated mean power of the transmitted spectrum on the assigned channel at each transmit antenna connector.

For UE with two transmit antenna connectors in closed-loop spatial multiplexing scheme, the occupied bandwidth at each transmitter antenna shall be less than the channel bandwidth specified in Table 6.6.1B-1. The requirements shall be met with the UL-MIMO configurations specified in Table 6.2.2B-2.

Table 6.6.1B-1: Occupied channel bandwidth

	Occupied channel bandwidth / Channel bandwidth					
	1.4 MHz	3.0 MHz	5 MHz	10 MHz	15 MHz	20 MHz
Channel bandwidth (MHz)	1.4	3	5	10	15	20

If UE is configured for transmission on single-antenna port, the requirements in subclause 6.6.1 apply.

6.6.2 Out of band emission

The Out of band emissions are unwanted emissions immediately outside the assigned channel bandwidth resulting from the modulation process and non-linearity in the transmitter but excluding spurious emissions. This out of band emission limit is specified in terms of a spectrum emission mask and an Adjacent Channel Leakage power Ratio.

6.6.2.1 Spectrum emission mask

The spectrum emission mask of the UE applies to frequencies (Δf_{OOB}) starting from the \pm edge of the assigned E-UTRA channel bandwidth. For frequencies greater than (Δf_{OOB}) as specified in Table 6.6.2.1.1-1 the spurious requirements in subclause 6.6.3 are applicable.

6.6.2.1.1 Minimum requirement

The power of any UE emission shall not exceed the levels specified in Table 6.6.2.1.1-1 for the specified channel bandwidth.

Table 6.6.2.1.1-1: General E-UTRA spectrum emission mask

Spectrum emission limit (dBm)/ Channel bandwidth							
Δf_{OoB} (MHz)	1.4 MHz	3.0 MHz	5 MHz	10 MHz	15 MHz	20 MHz	Measurement bandwidth
± 0 -1	-10	-13	-15	-18	-20	-21	30 kHz
± 1 -2.5	-10	-10	-10	-10	-10	-10	1 MHz
± 2.5 -2.8	-25	-10	-10	-10	-10	-10	1 MHz
± 2.8 -5		-10	-10	-10	-10	-10	1 MHz
± 5 -6		-25	-13	-13	-13	-13	1 MHz
± 6 -10			-25	-13	-13	-13	1 MHz
± 10 -15				-25	-13	-13	1 MHz
± 15 -20					-25	-13	1 MHz
± 20 -25						-25	1 MHz

NOTE: As a general rule, the resolution bandwidth of the measuring equipment should be equal to the measurement bandwidth. However, to improve measurement accuracy, sensitivity and efficiency, the resolution bandwidth may be smaller than the measurement bandwidth. When the resolution bandwidth is smaller than the measurement bandwidth, the result should be integrated over the measurement bandwidth in order to obtain the equivalent noise bandwidth of the measurement bandwidth.

6.6.2.1A Spectrum emission mask for CA

For intra-band contiguous carrier aggregation the spectrum emission mask of the UE applies to frequencies (Δf_{OoB}) starting from the \pm edge of the aggregated channel bandwidth (Table 5.6A-1) For intra-band contiguous carrier aggregation the bandwidth class C, the power of any UE emission shall not exceed the levels specified in Table 6.6.2.1A-1 for the specified channel bandwidth.

Table 6.6.2.1A-1: General E-UTRA CA spectrum emission mask for Bandwidth Class C

Spectrum emission limit [dBm]/BW _{Channel_CA}				
Δf_{OoB} (MHz)	50RB+100RB (29.9 MHz)	75RB+75RB (30 MHz)	100RB+100RB (39.8 MHz)	Measurement bandwidth
± 0 -1	-22.5	-22.5	-24	30 kHz
± 1 -5	-10	-10	-10	1 MHz
± 5 -29.9	-13	-13	-13	1 MHz
± 29.9 -30	-25	-13	-13	1 MHz
± 30 -34.9	-25	-25	-13	1 MHz
± 34.9 -35		-25	-13	1 MHz
± 35 -39.8			-13	1 MHz
± 39.8 -44.8			-25	1 MHz

6.6.2.2 Additional spectrum emission mask

This requirement is specified in terms of an "additional spectrum emission" requirement.

6.6.2.2.1 Minimum requirement (network signalled value "NS_03", "NS_11", and "NS_20")

Additional spectrum emission requirements are signalled by the network to indicate that the UE shall meet an additional requirement for a specific deployment scenario as part of the cell handover/broadcast message.

When "NS_03", "NS_11" or "NS_20" is indicated in the cell, the power of any UE emission shall not exceed the levels specified in Table 6.6.2.2.1-1.

Table 6.6.2.2.1-1: Additional requirements

Δf_{OoB} (MHz)	Spectrum emission limit (dBm)/ Channel bandwidth						
	1.4 MHz	3.0 MHz	5 MHz	10 MHz	15 MHz	20 MHz	Measurement bandwidth
$\pm 0-1$	-10	-13	-15	-18	-20	-21	30 kHz
$\pm 1-2.5$	-13	-13	-13	-13	-13	-13	1 MHz
$\pm 2.5-2.8$	-25	-13	-13	-13	-13	-13	1 MHz
$\pm 2.8-5$		-13	-13	-13	-13	-13	1 MHz
$\pm 5-6$		-25	-13	-13	-13	-13	1 MHz
$\pm 6-10$			-25	-13	-13	-13	1 MHz
$\pm 10-15$				-25	-13	-13	1 MHz
$\pm 15-20$					-25	-13	1 MHz
$\pm 20-25$						-25	1 MHz

NOTE: As a general rule, the resolution bandwidth of the measuring equipment should be equal to the measurement bandwidth. However, to improve measurement accuracy, sensitivity and efficiency, the resolution bandwidth may be smaller than the measurement bandwidth. When the resolution bandwidth is smaller than the measurement bandwidth, the result should be integrated over the measurement bandwidth in order to obtain the equivalent noise bandwidth of the measurement bandwidth.

6.6.2.2.2 Minimum requirement (network signalled value "NS_04")

Additional spectrum emission requirements are signalled by the network to indicate that the UE shall meet an additional requirement for a specific deployment scenario as part of the cell handover/broadcast message.

When "NS_04" is indicated in the cell, the power of any UE emission shall not exceed the levels specified in Table 6.6.2.2.2-1.

Table 6.6.2.2.2-1: Additional requirements

Δf_{OoB} (MHz)	Spectrum emission limit (dBm)/ Channel bandwidth						
	1.4 MHz	3.0 MHz	5 MHz	10 MHz	15 MHz	20 MHz	Measurement bandwidth
$\pm 0-1$	-10	-13	-15	-18	-20	-21	30 kHz
$\pm 1-2.5$	-13	-13	-13	-13	-13	-13	1 MHz
$\pm 2.5-2.8$	-25	-13	-13	-13	-13	-13	1 MHz
$\pm 2.8-5.5$		-13	-13	-13	-13	-13	1 MHz
$\pm 5.5-6$		-25	-25	-25	-25	-25	1 MHz
$\pm 6-10$			-25	-25	-25	-25	1 MHz
$\pm 10-15$				-25	-25	-25	1 MHz
$\pm 15-20$					-25	-25	1 MHz
$\pm 20-25$						-25	1 MHz

Note: As a general rule, the resolution bandwidth of the measuring equipment should be equal to the measurement bandwidth. However, to improve measurement accuracy, sensitivity and efficiency, the resolution bandwidth may be smaller than the measurement bandwidth. When the resolution bandwidth is smaller than the measurement bandwidth, the result should be integrated over the measurement bandwidth in order to obtain the equivalent noise bandwidth of the measurement bandwidth.

6.6.2.2.3 Minimum requirement (network signalled value "NS_06" or "NS_07")

Additional spectrum emission requirements are signalled by the network to indicate that the UE shall meet an additional requirement for a specific deployment scenario as part of the cell handover/broadcast message.

When "NS_06" or "NS_07" is indicated in the cell, the power of any UE emission shall not exceed the levels specified in Table 6.6.2.2.3-1.

Table 6.6.2.3-1: Additional requirements

Δf_{OOB} (MHz)	Spectrum emission limit (dBm)/ Channel bandwidth				
	1.4 MHz	3.0 MHz	5 MHz	10 MHz	Measurement bandwidth
$\pm 0-0.1$	-13	-13	-15	-18	30 kHz
$\pm 0.1-1$	-13	-13	-13	-13	100 kHz
$\pm 1-2.5$	-13	-13	-13	-13	1 MHz
$\pm 2.5-2.8$	-25	-13	-13	-13	1 MHz
$\pm 2.8-5$		-13	-13	-13	1 MHz
$\pm 5-6$		-25	-13	-13	1 MHz
$\pm 6-10$			-25	-13	1 MHz
$\pm 10-15$				-25	1 MHz

NOTE: As a general rule, the resolution bandwidth of the measuring equipment should be equal to the measurement bandwidth. However, to improve measurement accuracy, sensitivity and efficiency, the resolution bandwidth may be smaller than the measurement bandwidth. When the resolution bandwidth is smaller than the measurement bandwidth, the result should be integrated over the measurement bandwidth in order to obtain the equivalent noise bandwidth of the measurement bandwidth.

6.6.2.3 Adjacent Channel Leakage Ratio

Adjacent Channel Leakage power Ratio (ACLR) is the ratio of the filtered mean power centred on the assigned channel frequency to the filtered mean power centred on an adjacent channel frequency. ACLR requirements for one E-UTRA carrier are specified for two scenarios for an adjacent E-UTRA and /or UTRA channel as shown in Figure 6.6.2.3-1.

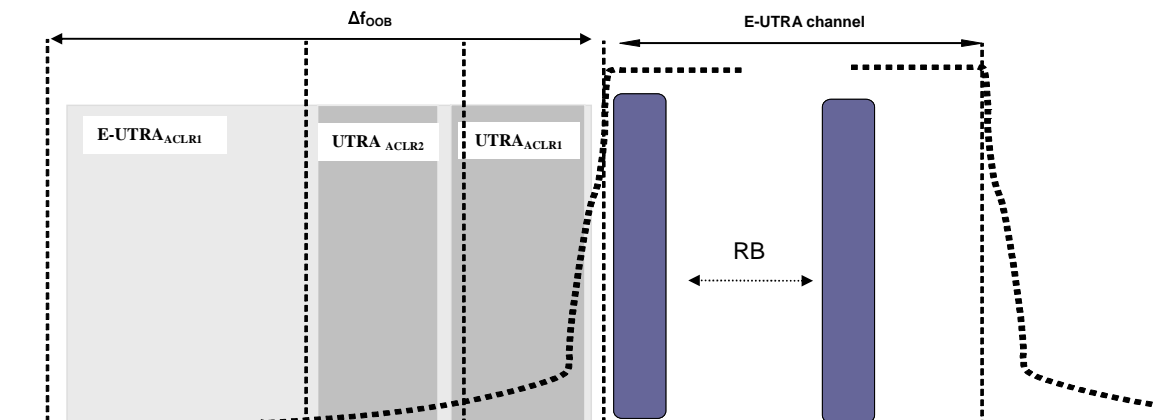

Figure 6.6.2.3-1: Adjacent Channel Leakage requirements for one E-UTRA carrier

6.6.2.3.1 Minimum requirement E-UTRA

E-UTRA Adjacent Channel Leakage power Ratio ($E\text{-UTRA}_{\text{ACLR}}$) is the ratio of the filtered mean power centred on the assigned channel frequency to the filtered mean power centred on an adjacent channel frequency at nominal channel spacing. The assigned E-UTRA channel power and adjacent E-UTRA channel power are measured with rectangular filters with measurement bandwidths specified in Table 6.6.2.3.1-1. If the measured adjacent channel power is greater than -50dBm then the $E\text{-UTRA}_{\text{ACLR}}$ shall be higher than the value specified in Table 6.6.2.3.1-1.

Table 6.6.2.3.1-1: General requirements for E-UTRA_{ACLR}

	Channel bandwidth / E-UTRA _{ACLR1} / Measurement bandwidth					
	1.4 MHz	3.0 MHz	5 MHz	10 MHz	15 MHz	20 MHz
E-UTRA _{ACLR1}	30 dB	30 dB	30 dB	30 dB	30 dB	30 dB
E-UTRA channel Measurement bandwidth	1.08 MHz	2.7 MHz	4.5 MHz	9.0 MHz	13.5 MHz	18 MHz
Adjacent channel centre frequency offset [MHz]	+1.4 / -1.4	+3.0 / -3.0	+5 / -5	+10 / -10	+15 / -15	+20 / -20

6.6.2.3.1A Void

6.6.2.3.2 Minimum requirements UTRA

UTRA Adjacent Channel Leakage power Ratio (UTRA_{ACLR}) is the ratio of the filtered mean power centred on the assigned E-UTRA channel frequency to the filtered mean power centred on an adjacent(s) UTRA channel frequency.

UTRA Adjacent Channel Leakage power Ratio is specified for both the first UTRA adjacent channel (UTRA_{ACLR1}) and the 2nd UTRA adjacent channel (UTRA_{ACLR2}). The UTRA channel power is measured with a RRC bandwidth filter with roll-off factor $\alpha = 0.22$. The assigned E-UTRA channel power is measured with a rectangular filter with measurement bandwidth specified in Table 6.6.2.3.2-1. If the measured UTRA channel power is greater than -50dBm then the UTRA_{ACLR} shall be higher than the value specified in Table 6.6.2.3.2-1.

Table 6.6.2.3.2-1: Requirements for UTRA_{ACLR1/2}

	Channel bandwidth / UTRA _{ACLR1/2} / Measurement bandwidth					
	1.4 MHz	3.0 MHz	5 MHz	10 MHz	15 MHz	20 MHz
UTRA _{ACLR1}	33 dB	33 dB	33 dB	33 dB	33 dB	33 dB
Adjacent channel centre frequency offset [MHz]	$0.7+BW_{\text{UTRA}}/2$ / $-0.7-BW_{\text{UTRA}}/2$	$1.5+BW_{\text{UTRA}}/2$ / $-1.5-BW_{\text{UTRA}}/2$	$+2.5+BW_{\text{UTRA}}/2$ / $-2.5-BW_{\text{UTRA}}/2$	$+5+BW_{\text{UTRA}}/2$ / $-5-BW_{\text{UTRA}}/2$	$+7.5+BW_{\text{UTRA}}/2$ / $-7.5-BW_{\text{UTRA}}/2$	$+10+BW_{\text{UTRA}}/2$ / $-10-BW_{\text{UTRA}}/2$
UTRA _{ACLR2}	-	-	36 dB	36 dB	36 dB	36 dB
Adjacent channel centre frequency offset [MHz]	-	-	$+2.5+3*BW_{\text{UTRA}}/2$ / $-2.5-3*BW_{\text{UTRA}}/2$	$+5+3*BW_{\text{UTRA}}/2$ / $-5-3*BW_{\text{UTRA}}/2$	$+7.5+3*BW_{\text{UTRA}}/2$ / $-7.5-3*BW_{\text{UTRA}}/2$	$+10+3*BW_{\text{UTRA}}/2$ / $-10-3*BW_{\text{UTRA}}/2$
E-UTRA channel Measurement bandwidth	1.08 MHz	2.7 MHz	4.5 MHz	9.0 MHz	13.5 MHz	18 MHz
UTRA 5MHz channel Measurement bandwidth (Note 1)	3.84 MHz	3.84 MHz	3.84 MHz	3.84 MHz	3.84 MHz	3.84 MHz
UTRA 1.6MHz channel measurement bandwidth (Note 2)	1.28 MHz	1.28 MHz	1.28 MHz	1.28MHz	1.28MHz	1.28MHz
NOTE 1:	Applicable for E-UTRA FDD co-existence with UTRA FDD in paired spectrum.					
NOTE 2:	Applicable for E-UTRA TDD co-existence with UTRA TDD in unpaired spectrum.					

6.6.2.3.2A Minimum requirement UTRA for CA

For intra-band contiguous carrier aggregation the UTRA Adjacent Channel Leakage power Ratio ($UTRA_{ACLR}$) is the ratio of the filtered mean power centred on the aggregated channel bandwidth to the filtered mean power centred on an adjacent(s) UTRA channel frequency.

UTRA Adjacent Channel Leakage power Ratio is specified for both the first UTRA adjacent channel ($UTRA_{ACLR1}$) and the 2nd UTRA adjacent channel ($UTRA_{ACLR2}$). The UTRA channel power is measured with a RRC bandwidth filter with roll-off factor $\alpha = 0.22$. The assigned aggregated channel bandwidth power is measured with a rectangular filter with measurement bandwidth specified in Table 6.6.2.3.2A-1. If the measured UTRA channel power is greater than -50dBm then the $UTRA_{ACLR}$ shall be higher than the value specified in Table 6.6.2.3.2A-1.

Table 6.6.2.3.2A-1: Requirements for $UTRA_{ACLR1/2}$

	CA bandwidth class / $UTRA_{ACLR1/2}$ / measurement bandwidth
CA bandwidth class C	
$UTRA_{ACLR1}$	33 dB
Adjacent channel centre frequency offset (in MHz)	$\frac{+ BW_{Channel_CA} / 2 + BW_{UTRA} / 2}{- BW_{Channel_CA} / 2 - BW_{UTRA} / 2}$
$UTRA_{ACLR2}$	36 dB
Adjacent channel centre frequency offset (in MHz)	$\frac{+ BW_{Channel_CA} / 2 + 3 * BW_{UTRA} / 2}{- BW_{Channel_CA} / 2 - 3 * BW_{UTRA} / 2}$
CA E-UTRA channel Measurement bandwidth	$BW_{Channel_CA} - 2 * BW_{GB}$
UTRA 5MHz channel Measurement bandwidth (Note 1)	3.84 MHz
UTRA 1.6MHz channel measurement bandwidth (Note 2)	1.28 MHz
NOTE 1: Applicable for E-UTRA FDD co-existence with UTRA FDD in paired spectrum.	
NOTE 2: Applicable for E-UTRA TDD co-existence with UTRA TDD in unpaired spectrum.	

6.6.2.3.3A Minimum requirements for CA E-UTRA

For intra-band contiguous carrier aggregation the carrier aggregation E-UTRA Adjacent Channel Leakage power Ratio (CA E- $UTRA_{ACLR}$) is the ratio of the filtered mean power centred on the aggregated channel bandwidth to the filtered mean power centred on an adjacent aggregated channel bandwidth at nominal channel spacing. The assigned aggregated channel bandwidth power and adjacent aggregated channel bandwidth power are measured with rectangular filters with measurement bandwidths specified in Table 6.6.2.3.3A-1. If the measured adjacent channel power is greater than -50dBm then the $E-UTRA_{ACLR}$ shall be higher than the value specified in Table 6.6.2.3.3A-1.

Table 6.6.2.3.3A-1: General requirements for CA E- $UTRA_{ACLR}$

	CA bandwidth class / CA E- $UTRA_{ACLR}$ / Measurement bandwidth
CA bandwidth class C	
CA E- $UTRA_{ACLR}$	30 dB
CA E-UTRA channel Measurement bandwidth	$BW_{Channel_CA} - 2 * BW_{GB}$
Adjacent channel centre frequency offset (in MHz)	$\frac{+ BW_{Channel_CA}}{- BW_{Channel_CA}}$

6.6.2.4 Void

6.6.2.4.1 Void

6.6.2A Void

<reserved for future use>

6.6.2B Out of band emission for UL-MIMO

For UE supporting UL-MIMO, the requirements for Out of band emissions resulting from the modulation process and non-linearity in the transmitters are specified at each transmit antenna connector.

For UEs with two transmit antenna connectors in closed-loop spatial multiplexing scheme, the requirements in subclause 6.6.2 apply to each transmit antenna connector. The requirements shall be met with the UL-MIMO configurations specified in Table 6.2.2B-2.

If UE is configured for transmission on single-antenna port, the requirements in subclause 6.6.2 apply.

6.6.3 Spurious emissions

Spurious emissions are emissions which are caused by unwanted transmitter effects such as harmonics emission, parasitic emissions, intermodulation products and frequency conversion products, but exclude out of band emissions unless otherwise stated. The spurious emission limits are specified in terms of general requirements inline with SM.329 [2] and E-UTRA operating band requirement to address UE co-existence.

To improve measurement accuracy, sensitivity and efficiency, the resolution bandwidth may be smaller than the measurement bandwidth. When the resolution bandwidth is smaller than the measurement bandwidth, the result should be integrated over the measurement bandwidth in order to obtain the equivalent noise bandwidth of the measurement bandwidth.

6.6.3.1 Minimum requirements

Unless otherwise stated, the spurious emission limits apply for the frequency ranges that are more than F_{OOB} (MHz) in Table 6.6.3.1-1 from the edge of the channel bandwidth. The spurious emission limits in Table 6.6.3.1-2 apply for all transmitter band configurations (N_{RB}) and channel bandwidths.

NOTE: For measurement conditions at the edge of each frequency range, the lowest frequency of the measurement position in each frequency range should be set at the lowest boundary of the frequency range plus $MBW/2$. The highest frequency of the measurement position in each frequency range should be set at the highest boundary of the frequency range minus $MBW/2$. MBW denotes the measurement bandwidth defined for the protected band.

Table 6.6.3.1-1: Boundary between E-UTRA out of band and spurious emission domain

Channel bandwidth	1.4 MHz	3.0 MHz	5 MHz	10 MHz	15 MHz	20 MHz
OOB boundary F_{OOB} (MHz)	2.8	6	10	15	20	25

Table 6.6.3.1-2: Spurious emissions limits

Frequency Range	Maximum Level	Measurement bandwidth	Note
$9 \text{ kHz} \leq f < 150 \text{ kHz}$	-36 dBm	1 kHz	
$150 \text{ kHz} \leq f < 30 \text{ MHz}$	-36 dBm	10 kHz	
$30 \text{ MHz} \leq f < 1000 \text{ MHz}$	-36 dBm	100 kHz	
$1 \text{ GHz} \leq f < 12.75 \text{ GHz}$	-30 dBm	1 MHz	
$12.75 \text{ GHz} \leq f < 5^{\text{th}}$ harmonic of the upper frequency edge of the UL operating band in GHz	-30 dBm	1 MHz	1
NOTE 1: Applies for Band 22, Band 42 and Band 43			

6.6.3.1A Minimum requirements for CA

This clause specifies the spurious emission requirements for carrier aggregation.

NOTE: For measurement conditions at the edge of each frequency range, the lowest frequency of the measurement position in each frequency range should be set at the lowest boundary of the frequency range plus MBW/2. The highest frequency of the measurement position in each frequency range should be set at the highest boundary of the frequency range minus MBW/2. MBW denotes the measurement bandwidth defined for the protected band.

For intra-band contiguous carrier aggregation the spurious emission limits apply for the frequency ranges that are more than F_{OOB} (MHz) in Table 6.6.3.1A-1 from the edge of the aggregated channel bandwidth (Table 5.6A-1). For frequencies Δf_{OOB} greater than F_{OOB} as specified in Table 6.6.3.1A-1 the spurious emission requirements in Table 6.6.3.1-2 are applicable.

Table 6.6.3.1A-1: Boundary between E-UTRA out of band and spurious emission domain for intra-band contiguous carrier aggregation

CA Bandwidth Class	OOB boundary F_{OOB} (MHz)
A	Table 6.6.3.1-1
B	FFS
C	$BW_{\text{Channel_CA}} + 5$

6.6.3.2 Spurious emission band UE co-existence

This clause specifies the requirements for the specified E-UTRA band, for coexistence with protected bands.

NOTE: For measurement conditions at the edge of each frequency range, the lowest frequency of the measurement position in each frequency range should be set at the lowest boundary of the frequency range plus MBW/2. The highest frequency of the measurement position in each frequency range should be set at the highest boundary of the frequency range minus MBW/2. MBW denotes the measurement bandwidth defined for the protected band.

Table 6.6.3.2-1: Requirements

E-UTRA Band	Spurious emission						
	Protected band	Frequency range (MHz)		Maximum Level (dBm)	MBW (MHz)	Note	
1	E-UTRA Band 1, 3, 7, 8, 11, 18, 19, 20, 21, 22, 38, 40, 42, 43	F _{DL_low}	-	F _{DL_high}	-50	1	
	E-UTRA Band 34	F _{DL_low}	-	F _{DL_high}	-50	1	15
	Frequency range	1880	-	1895	-40	1	15,19
	Frequency range	1895	-	1915	-15.5	5	15,19,20
	Frequency range	1915	-	1920	+1.6	5	15,19,20
2	E-UTRA Band 4, 5, 10, 12, 13, 14, 17, 23, 24, 41, 42	F _{DL_low}	-	F _{DL_high}	-50	1	
	E-UTRA Band 2, 25	F _{DL_low}	-	F _{DL_high}	-50	1	15
	E-UTRA Band 43	F _{DL_low}	-	F _{DL_high}	-50	1	2
3	E-UTRA Band 1, 7, 8, 11, 18, 19, 20, 21, 33, 34, 38, 43	F _{DL_low}	-	F _{DL_high}	-50	1	
	E-UTRA Band 3	F _{DL_low}	-	F _{DL_high}	-50	1	15
	E-UTRA Band 22, 42	F _{DL_low}	-	F _{DL_high}	-50	1	2
	Frequency range	1884.5	-	1915.7	-41	0.3	
4	E-UTRA Band 2, 4, 5, 10, 12, 13, 14, 17, 23, 24, 25, 41, 43	F _{DL_low}	-	F _{DL_high}	-50	1	
	E-UTRA Band 42	F _{DL_low}	-	F _{DL_high}	-50	1	2
5	E-UTRA Band 2, 4, 5, 10, 12, 13, 14, 17, 23, 24, 25, 42, 43	F _{DL_low}	-	F _{DL_high}	-50	1	
	E-UTRA Band 41	F _{DL_low}	-	F _{DL_high}	-50	1	2
6	E-UTRA Band 1, 9, 11, 34	F _{DL_low}	-	F _{DL_high}	-50	1	
	Frequency range	860	-	875	-37	1	
	Frequency range	875	-	895	-50	1	
	Frequency range	1884.5	-	1919.6	-41	0.3	7
	Frequency range	1884.5	-	1915.7	-41	0.3	8
7	E-UTRA Band 1, 3, 7, 8, 20, 22, 33, 34, 40, 42, 43	F _{DL_low}	-	F _{DL_high}	-50	1	
	Frequency range	2570	-	2575	+1.6	5	15, 16, 20
	Frequency range	2575	-	2595	-15.5	5	15, 16, 20
	Frequency range	2595	-	2620	-40	1	15, 16
8	E-UTRA Band 1, 20, 33, 34, 38, 39, 40	F _{DL_low}	-	F _{DL_high}	-50	1	
	E-UTRA band 3	F _{DL_low}	-	F _{DL_high}	-50	1	2
	E-UTRA band 7	F _{DL_low}	-	F _{DL_high}	-50	1	2
	E-UTRA Band 8	F _{DL_low}	-	F _{DL_high}	-50	1	15
	E-UTRA Band 22, 42, 43	F _{DL_low}	-	F _{DL_high}	-50	1	2
	E-UTRA Band 11, 21	F _{DL_low}	-	F _{DL_high}	-50	1	18
	Frequency range	860	-	890	-40	1	15, 18
	Frequency range	1884.5	-	1915.7	-41	0.3	8, 18
9	E-UTRA Band 1, 3, 11, 18, 19, 21, 34	F _{DL_low}	-	F _{DL_high}	-50	1	
	E-UTRA Band 42	F _{DL_low}	-	F _{DL_high}	-50	1	2
	Frequency range	1884.5	-	1915.7	-41	0.3	8
	Frequency range	945	-	960	-50	1	
10	E-UTRA Band 2, 4, 5, 10, 12, 13, 14, 17, 23, 24, 25, 41, 43	F _{DL_low}	-	F _{DL_high}	-50	1	
	E-UTRA Band 22, 42	F _{DL_low}	-	F _{DL_high}	-50	1	2
11	E-UTRA Band 1, 3, 11, 18, 19, 21, 34, 42	F _{DL_low}	-	F _{DL_high}	-50	1	
	Frequency range	1884.5	-	1915.7	-41	0.3	8
	Frequency range	945	-	960	-50	1	
12	E-UTRA Band 2, 5, 13, 14, 17, 23, 24, 25, 41	F _{DL_low}	-	F _{DL_high}	-50	1	
	E-UTRA Band 4, 10	F _{DL_low}	-	F _{DL_high}	-50	1	2
	E-UTRA Band 12	F _{DL_low}	-	F _{DL_high}	-50	1	15
13	E-UTRA Band 2, 4, 5, 10, 12, 13, 17, 23, 25, 41	F _{DL_low}	-	F _{DL_high}	-50	1	
	Frequency range	769	-	775	-35	0.00625	15
	Frequency range	799	-	805	-35	0.00625	11, 15
	E-UTRA Band 14	F _{DL_low}	-	F _{DL_high}	-50	1	15
	E-UTRA Band 24	F _{DL_low}	-	F _{DL_high}	-50	1	2

14	E-UTRA Band 2, 4, 5, 10, 12, 13, 14, 17, 23, 24, 25, 41	F _{DL_low}	-	F _{DL_high}	-50	1	
	Frequency range	769	-	775	-35	0.00625	12, 15
	Frequency range	799	-	805	-35	0.00625	11, 12, 15
17	E-UTRA Band 2, 5, 13, 14, 17, 23, 24, 25, 41	F _{DL_low}	-	F _{DL_high}	-50	1	
	E-UTRA Band 4, 10	F _{DL_low}	-	F _{DL_high}	-50	1	2
	E-UTRA Band 12	F _{DL_low}	-	F _{DL_high}	-50	1	15
18	E-UTRA Band 1, 3, 11, 21, 34, 42	F _{DL_low}	-	F _{DL_high}	-50	1	
	Frequency range	860	-	890	-40	1	
	Frequency range	1884.5	-	1915.7	-41	0.3	8
	Frequency range	945	-	960	-50	1	
19	E-UTRA Band 1, 3, 11, 21, 34, 42	F _{DL_low}	-	F _{DL_high}	-50	1	
	Frequency range	1884.5	-	1915.7	-41	0.3	8
	Frequency range	945	-	960	-50	1	
20	E-UTRA Band 1, 3, 7, 8, 20, 22, 33, 34, 40, 43	F _{DL_low}	-	F _{DL_high}	-50	1	
	E-UTRA Band 20	F _{DL_low}	-	F _{DL_high}	-50	1	15
	E-UTRA Band 38, 42	F _{DL_low}	-	F _{DL_high}	-50	1	2
21	E-UTRA Band 1, 3, 18, 19, 34, 42	F _{DL_low}	-	F _{DL_high}	-50	1	
	Frequency range	1884.5	-	1915.7	-41	0.3	8
	Frequency range	945	-	960	-50	1	
22	E-UTRA Band 1, 3, 7, 8, 20, 33, 34, 38, 39, 40, 43	F _{DL_low}	-	F _{DL_high}	-50	1	
	Frequency range	3510	-	3525	-40	1	15
	Frequency range	3525	-	3590	-50	1	
23	E-UTRA Band 4, 5, 10, 12, 13, 14, 17, 23, 24, 41	F _{DL_low}	-	F _{DL_high}	-50	1	
24	E-UTRA Band 2, 4, 5, 10, 12, 13, 14, 17, 23, 24, 25, 41	F _{DL_low}	-	F _{DL_high}	-50	1	
25	E-UTRA Band 4, 5, 10, 12, 13, 14, 17, 23, 24, 41, 42	F _{DL_low}	-	F _{DL_high}	-50	1	
	E-UTRA Band 2	F _{DL_low}	-	F _{DL_high}	-50	1	15
	E-UTRA Band 25	F _{DL_low}	-	F _{DL_high}	-50	1	15
	E-UTRA Band 43	F _{DL_low}	-	F _{DL_high}	-50	1	2
...							
33	E-UTRA Band 1, 7, 8, 20, 22, 34, 38, 40, 42, 43	F _{DL_low}	-	F _{DL_high}	-50	1	5
	E-UTRA Band 3	F _{DL_low}	-	F _{DL_high}	-50	1	15
34	E-UTRA Band 1, 3, 7, 8, 11, 18, 19, 20, 21, 22, 33, 38, 39, 40, 42, 43	F _{DL_low}	-	F _{DL_high}	-50	1	5
	Frequency range	1884.5	-	1915.7	-41	0.3	8
35							
36							
37			-				
38	E-UTRA Band 1, 3, 8, 20, 22, 33, 34, 40, 42, 43	F _{DL_low}	-	F _{DL_high}	-50	1	
	Frequency range	2620	-	2645	-15.5	5	15, 17, 20
	Frequency range	2645	-	2690	-40	1	15, 17
39	E-UTRA Band 22, 34, 40, 42	F _{DL_low}	-	F _{DL_high}	-50	1	
	E-UTRA Band 43	F _{DL_low}	-	F _{DL_high}	-50	1	2
40	E-UTRA Band 1, 3, 7, 8, 20, 22, 33, 34, 38, 39, 42, 43	F _{DL_low}	-	F _{DL_high}	-50	1	
41	E-UTRA Band 2, 4, 5, 10, 12, 13, 14, 17, 23, 24, 25	F _{DL_low}	-	F _{DL_high}	-50	1	
42	E-UTRA Band 1, 2, 3, 4, 5, 7, 8, 10, 11, 18, 19, 20, 21, 25, 33, 34, 38, 40	F _{DL_low}	-	F _{DL_high}	-50	1	
	Frequency range	1884.5	-	1915.7	-41	0.3	8
43	E-UTRA Band 1, 2, 3, 4, 5, 7, 8, 10, 20, 25, 33, 34, 38, 40	F _{DL_low}	-	F _{DL_high}	-50	1	
NOTE 1: F _{DL_low} and F _{DL_high} refer to each E-UTRA frequency band specified in Table 5.5-1							
NOTE 2: As exceptions, measurements with a level up to the applicable requirements defined in Table 6.6.3.1-2 are permitted for each assigned E-UTRA carrier used in the measurement due to 2 nd , 3 rd , 4 th [or 5 th] harmonic							

spurious emissions. Due to spreading of the harmonic emission the exception is also allowed for the first 1 MHz frequency range immediately outside the harmonic emission on both sides of the harmonic emission. This results in an overall exception interval centred at the harmonic emission of $(2\text{MHz} + N \times L_{\text{CRB}} \times 180\text{kHz})$, where N is 2, 3, 4, [5] for the 2nd, 3rd, 4th [or 5th] harmonic respectively. The exception is allowed if the measurement bandwidth (MBW) totally or partially overlaps the overall exception interval.

NOTE 3: N/A

NOTE 4: N/A

NOTE 5: For non synchronised TDD operation to meet these requirements some restriction will be needed for either the operating band or protected band

NOTE 6: N/A.

NOTE 7: Applicable when co-existence with PHS system operating in 1884.5-1919.6MHz.

NOTE 8: Applicable when co-existence with PHS system operating in 1884.5 -1915.7MHz.

NOTE 9: N/A.

NOTE 10: N/A.

NOTE 11: Whether the applicable frequency range should be 793-805MHz instead of 799-805MHz is TBD

NOTE 12: The emissions measurement shall be sufficiently power averaged to ensure a standard deviation < 0.5 dB

NOTE 13: N/A.

NOTE 14: N/A.

NOTE 15: These requirements also apply for the frequency ranges that are less than F_{OoB} (MHz) in Table 6.6.3.1-1 and Table 6.6.3.1A-1 from the edge of the channel bandwidth.

NOTE 16: This requirement is applicable for any channel bandwidths within the range 2500 - 2570 MHz with the following restriction: for carriers of 15 MHz bandwidth when carrier centre frequency is within the range 2560.5 - 2562.5 MHz and for carriers of 20 MHz bandwidth when carrier centre frequency is within the range 2552 - 2560 MHz the requirement is applicable only for an uplink transmission bandwidth less than or equal to 54 RB.

NOTE 17: This requirement is applicable for any channel bandwidths within the range 2570 - 2615 MHz with the following restriction: for carriers of 15 MHz bandwidth when carrier centre frequency is within the range 2605.5 - 2607.5 MHz and for carriers of 20 MHz bandwidth when carrier centre frequency is within the range 2597 - 2605 MHz the requirement is applicable only for an uplink transmission bandwidth less than or equal to 54 RB.

For carriers with channel bandwidth overlapping the frequency range 2615 - 2620 MHz the requirement applies with the maximum output power configured to +19 dBm in the IE *P-Max*. NOTE 18: This requirement is applicable only for the following cases:

- for carriers of 5 MHz channel bandwidth when carrier centre frequency (F_c) is within the range $902.5 \text{ MHz} \leq F_c < 907.5 \text{ MHz}$ with an uplink transmission bandwidth less than or equal to 20 RB
- for carriers of 5 MHz channel bandwidth when carrier centre frequency (F_c) is within the range $907.5 \text{ MHz} \leq F_c \leq 912.5 \text{ MHz}$ without any restriction on uplink transmission bandwidth.
- for carriers of 10 MHz channel bandwidth when carrier centre frequency (F_c) is $F_c = 910 \text{ MHz}$ with an uplink transmission bandwidth less than or equal to 32 RB with $\text{RB}_{\text{start}} > 3$.

NOTE 19: This requirement is applicable for any channel bandwidths within the range 1920 - 1980 MHz with the following restriction: for carriers of 15 MHz bandwidth when carrier centre frequency is within the range 1927.5 - 1929.5 MHz and for carriers of 20 MHz bandwidth when carrier centre frequency is within the range 1930 - 1938 MHz the requirement is applicable only for an uplink transmission bandwidth less than or equal to 54 RB.

NOTE 20: For these adjacent bands, the emission limit could imply risk of harmful interference to UE(s) operating in the protected operating band.

NOTE 21 N/A.

NOTE 22 N/A.

NOTE: The restriction on the maximum uplink transmission to 54 RB in Notes 16, 17, and 19 of Table 6.6.3.2-1 is intended for conformance testing and may be applied to network operation to facilitate coexistence when the aggressor and victim bands are deployed in the same geographical area. The applicable spurious emission requirement of -15.5 dBm/5MHz is a least restrictive technical condition for FDD/TDD coexistence and may have to be revised in the future.

6.6.3.2A Spurious emission band UE co-existence for CA

This clause specifies the requirements for the specified carrier aggregation configurations for coexistence with protected bands.

NOTE: For measurement conditions at the edge of each frequency range, the lowest frequency of the measurement position in each frequency range should be set at the lowest boundary of the frequency range plus MBW/2. The highest frequency of the measurement position in each frequency range should be set at the highest boundary of the frequency range minus MBW/2. MBW denotes the measurement bandwidth defined for the protected band.

Table 6.6.3.2A-1: Requirements

E-UTRA CA Configuration	Spurious emission						
	Protected band	Frequency range (MHz)			Maximum Level (dBm)	MBW (MHz)	Note
CA_1C	E-UTRA Band 1, 7, 8, 11, 18, 19, 20, 21, 22, 38, 40, 42, 43	F _{DL_low}	-	F _{DL_high}	-50	1	
	E-UTRA Band 3	F _{DL_low}	-	F _{DL_high}	-50	1	8
CA_40C	E-UTRA Band 1, 3, 7, 8, 20, 22, 33, 34, 38, 39, 42, 43	F _{DL_low}	-	F _{DL_high}	-50	1	
<p>NOTE 1: FDL_low and FDL_high refer to each E-UTRA frequency band specified in Table 5.5-1</p> <p>NOTE 2: As exceptions, measurements with a level up to the applicable requirements defined in Table 6.6.3.1-2 are permitted for each assigned E-UTRA carrier used in the measurement due to 2nd, 3rd, 4th [or 5th] harmonic spurious emissions. Due to spreading of the harmonic emission the exception is also allowed for the first 1 MHz frequency range immediately outside the harmonic emission on both sides of the harmonic emission. This results in an overall exception interval centred at the harmonic emission of (2MHz + N x L_{CRB} x 180kHz), where N is 2, 3, 4, [5] for the 2nd, 3rd, 4th [or 5th] harmonic respectively. The exception is allowed if the measurement bandwidth (MBW) totally or partially overlaps the overall exception interval.</p> <p>NOTE 3: To meet these requirements some restriction will be needed for either the operating band or protected band</p> <p>NOTE 4: N/A</p> <p>NOTE 5: N/A</p> <p>NOTE 6: N/A</p> <p>NOTE 7: N/A</p> <p>NOTE 8: The requirement also applies for the frequency ranges that are less than F_{OOB} (MHz) in Table 6.6.3.1-1 and Table 6.6.3.1A-1 from the edge of the channel bandwidth.</p> <p>NOTE 9: N/A</p>							

6.6.3.3 Additional spurious emissions

These requirements are specified in terms of an additional spectrum emission requirement. Additional spurious emission requirements are signalled by the network to indicate that the UE shall meet an additional requirement for a specific deployment scenario as part of the cell handover/broadcast message.

NOTE: For measurement conditions at the edge of each frequency range, the lowest frequency of the measurement position in each frequency range should be set at the lowest boundary of the frequency range plus MBW/2. The highest frequency of the measurement position in each frequency range should be set at the highest boundary of the frequency range minus MBW/2. MBW denotes the measurement bandwidth defined for the protected band.

6.6.3.3.1 Minimum requirement (network signalled value "NS_05")

When "NS_05" is indicated in the cell, the power of any UE emission shall not exceed the levels specified in Table 6.6.3.3.1-1. This requirement also applies for the frequency ranges that are less than F_{OOB} (MHz) in Table 6.6.3.1-1 from the edge of the channel bandwidth.

Table 6.6.3.3.1-1: Additional requirements (PHS)

Frequency band (MHz)	Channel bandwidth / Spectrum emission limit (dBm)				Measurement bandwidth	Note
	5 MHz	10 MHz	15 MHz	20 MHz		
$1884.5 \leq f \leq 1915.7$	-41	-41	-41	-41	300 KHz	1
NOTE 1: Applicable when the lower edge of the assigned E-UTRA UL channel bandwidth frequency is larger than or equal to the upper edge of PHS band (1915.7 MHz) + 4 MHz + the channel BW assigned, where channel BW is as defined in subclause 5.6. Additional restrictions apply for operations below this point.						

The requirements in Table 6.6.3.3.1-1 apply with the additional restrictions specified in Table 6.6.3.3.1-2 when the lower edge of the assigned E-UTRA UL channel bandwidth frequency is less than the upper edge of PHS band (1915.7 MHz) + 4 MHz + the channel BW assigned.

Table 6.6.3.3.1-2: RB restrictions for additional requirement (PHS).

15 MHz channel bandwidth with $f_c = 1932.5$ MHz			
RB_{start}	0-7	8-66	67-74
L_{CRB}	N/A	$\leq \text{MIN}(30, 67 - RB_{start})$	N/A
20 MHz channel bandwidth with $f_c = 1930$ MHz			
RB_{start}	0-23	24-75	76-99
L_{CRB}	N/A	$\leq \text{MIN}(24, 76 - RB_{start})$	N/A

6.6.3.3.2 Minimum requirement (network signalled value "NS_07")

When "NS_07" is indicated in the cell, the power of any UE emission shall not exceed the levels specified in Table 6.6.3.3.2-1. This requirement also applies for the frequency ranges that are less than F_{OOB} (MHz) in Table 6.6.3.1-1 from the edge of the channel bandwidth.

Table 6.6.3.3.2-1: Additional requirements

Frequency band (MHz)	Channel bandwidth / Spectrum emission limit (dBm)	Measurement bandwidth
	10 MHz	
$769 \leq f \leq 775$	-57	6.25 kHz
NOTE: The emissions measurement shall be sufficiently power averaged to ensure standard deviation < 0.5 dB.		

6.6.3.3.3 Minimum requirement (network signalled value "NS_08")

When "NS_08" is indicated in the cell, the power of any UE emission shall not exceed the levels specified in Table 6.6.3.3.3-1. This requirement also applies for the frequency ranges that are less than F_{OOB} (MHz) in Table 6.6.3.1-1 from the edge of the channel bandwidth.

Table 6.6.3.3.3-1: Additional requirement

Frequency band (MHz)	Channel bandwidth / Spectrum emission limit (dBm)			Measurement bandwidth
	5MHz	10MHz	15MHz	
$860 \leq f \leq 890$	-40	-40	-40	1 MHz

6.6.3.3.4 Minimum requirement (network signalled value "NS_09")

When "NS 09" is indicated in the cell, the power of any UE emission shall not exceed the levels specified in Table 6.6.3.3.4-1. This requirement also applies for the frequency ranges that are less than F_{OOB} (MHz) in Table 6.6.3.1-1 from the edge of the channel bandwidth.

Table 6.6.3.3.4-1: Additional requirement

Frequency band (MHz)	Channel bandwidth / Spectrum emission limit (dBm)			Measurement bandwidth
	5MHz	10MHz	15MHz	
$1475.9 \leq f \leq 1510.9$	-35	-35	-35	1 MHz

NOTE 1: Void

NOTE 2: To improve measurement accuracy, A-MPR values for NS_09 specified in Table 6.2.4-1 in subclause 6.2.4 are derived based on 100 kHz RBW.

6.6.3.3.5 Void

6.6.3.3.6 Void

6.6.3.3.7 Void

6.6.3.3.8 Void

6.6.3.3.9 Void

6.6.3.3.10 Void

6.6.3.3.11 Void

6.6.3.3.12 Void

6.6.3.3.13 Minimum requirement (network signalled value " NS_11")

When " NS_11" is indicated in the cell, the power of any UE emission shall not exceed the levels specified in Table 6.6.3.3.13-1. These requirements also apply for the frequency ranges that are less than F_{OOB} (MHz) in Table 6.6.3.1-1 and Table 6.6.3.1A-1 from the edge of the channel bandwidth.

Table 6.6.3.3.13-1: Additional requirements

Frequency band (MHz)	Channel bandwidth / Spectrum emission limit (dBm)	Measurement bandwidth
	1.4, 3, 5, 10, 15, 20 MHz	
E-UTRA Band 2	-50	1 MHz
$1998 \leq f \leq 1999$	-21	1 MHz
$1997 \leq f < 1998$	-27	1 MHz
$1996 \leq f < 1997$	-32	1 MHz
$1995 \leq f < 1996$	-37	1 MHz
$1990 \leq f < 1995$	-40	1 MHz

6.6.3.3.14 Minimum requirement (network signalled value " NS_20")

When " NS_20" is indicated in the cell, the power of any UE emission shall not exceed the levels specified in Table 6.6.3.3.14-1. These requirements also apply for the frequency ranges that are less than F_{OOB} (MHz) in Table 6.6.3.1-1 and Table 6.6.3.1A-1 from the edge of the channel bandwidth.

Table 6.6.3.3.14-1: Additional requirements

Frequency band (MHz)	Channel bandwidth / Spectrum emission limit (dBm)	Measurement bandwidth
	5, 10, 15, 20 MHz	
$1990 \leq f < 1999$	-40	1 MHz
$1999 \leq f \leq 2000$	-40	Note 1
Note 1: The measurement bandwidth is 1% of the applicable E-UTRA channel bandwidth.		

6.6.3.3.15 Minimum requirement (network signalled value "NS_22")

When "NS 22" is indicated in the cell, the power of any UE emission shall not exceed the levels specified in Table 6.6.3.3.15-1. This requirement also applies for the frequency ranges that are less than F_{OoB} (MHz) in Table 6.6.3.1-1 from the edge of the channel bandwidth.

Table 6.6.3.3.15-1: Additional requirement

Frequency band (MHz)	Channel bandwidth / Spectrum emission limit (dBm)	MBW
	5, 10, 15, 20 MHz	
$3400 \leq f \leq 3800$	-23 (Note 1, Note 3)	5 MHz
	-40 (Note 2)	1 MHz
Note 1: This requirement applies within an offset between 5 MHz and 25 MHz from the lower and from the upper edge of the channel bandwidth, whenever these frequencies overlap with the specified frequency band. Note 2: This requirement applies from 3400 MHz to 25 MHz below the lower E-UTRA channel edge and from 25 MHz above the upper E-UTRA channel edge to 3800 MHz. Note 3: This emission limit might imply risk of harmful interference to UE(s) operating in the protected operating band.		

6.6.3.3.16 Minimum requirement (network signalled value "NS_23")

When "NS 23" is indicated in the cell, the power of any UE emission shall not exceed the levels specified in Table 6.6.3.3.16-1. This requirement also applies for the frequency ranges that are less than F_{OoB} (MHz) in Table 6.6.3.1-1 from the edge of the channel bandwidth.

Table 6.6.3.3.16-1: Additional requirement

Frequency band (MHz)	Channel bandwidth / Spectrum emission limit (dBm)	MBW
	5, 10, 15, 20 MHz	
$3400 \leq f \leq 3800$	-23 (Note 1, Note 4)	5 MHz
	-40 (Note 2)	1 MHz
NOTE 1: This requirement applies within an offset between $5 \text{ MHz} + F_{\text{offset_NS_23}}$ and $25 \text{ MHz} + F_{\text{offset_NS_23}}$ from the lower and from the upper edges of the channel bandwidth, whenever these frequencies overlap with the specified frequency band. NOTE 2: This requirement applies from 3400 MHz to $25 \text{ MHz} + F_{\text{offset_NS_23}}$ below the lower E-UTRA channel edge and from $25 \text{ MHz} + F_{\text{offset_NS_23}}$ above the upper E-UTRA channel edge to 3800 MHz. NOTE 3: $F_{\text{offset_NS_23}}$ is: 0 MHz for 5 MHz channel BW, 5 MHz for 10 MHz channel BW, 9 MHz for 15 MHz channel BW and 12 MHz for 20 MHz channel BW. NOTE 4: This emission limit might imply risk of harmful interference to UE(s) operating in the protected operating band.		

6.6.3.3.17 Void

Table 6.6.3.3.17-1: Void

6.6.3.3.18 Void

Table 6.6.3.3.18-1: Void

6.6.3.3.19 Void

Table 6.6.3.3.19-1: Void

6.6.3.3.20 Void

Table 6.6.3.3.20-1: Void

6.6.3.3.21 Void

Table 6.6.3.3.21-1: Void

6.6.3.3.22 Void

Table 6.6.3.3.22-1: Void

6.6.3.3.23 Void

Table 6.6.3.3.23-1: Void

6.6.3.3.24 Void

Table 6.6.3.3.24-1: Void

6.6.3.3.25 Void

Table 6.6.3.3.25-1: Void

6.6.3.3.26 Void

Table 6.6.3.3.26-1: Void

Table 6.6.3.3.26-2: Void

Table 6.6.3.3.26-3: Void

6.6.3.3.27 Void

Table 6.6.3.3.27-1: Void

Table 6.6.3.3.27-2: Void

Table 6.6.3.3.27-3: Void

Table 6.6.3.3.27-4: Void

6.6.3.3.28 Void

Table 6.6.3.3.28-1: Void

6.6.3.3.29 Void

Table 6.6.3.3.29-1: Void

6.6.3.3.30 Void

Table 6.6.3.3.30-1: Void

6.6.3.3.31 Void

Table 6.6.3.3.31-1: Void

6.6.3.3.32 Void

Table 6.6.3.3.32-1: Void

6.6.3.3.33 Void

Table 6.6.3.3.33-1: Void

6.6.3.3.34 Void

Table 6.6.3.3.34-1: Void**Table 6.6.3.3.34-2: Void**

6.6.3.3.35 Minimum requirement (network signalled value "NS_56")

When "NS_56" is indicated in the cell, the power of any UE emission shall not exceed the levels specified in Table 6.6.3.3.35-1. This requirement also applies for the frequency ranges that are less than F_{OOB} (MHz) in Table 6.6.3.1-1 from the edge of the channel bandwidth.

Table 6.6.3.3.35-1: Additional requirements

Frequency band (MHz)	Channel bandwidth / Spectrum emission limit ¹ (dBm)	Measurement bandwidth	NOTE
	5 MHz, 10MHz		
$1541 \leq f \leq 1559$	-102	2kHz	Averaged over any 2 millisecond active transmission interval
$1559 \leq f \leq 1608$	-85	700Hz	
$1608 \leq f \leq 1610$	$-85 + 5/2 (f-1608)$	700Hz	
$1610 \leq f \leq 1625$	$-80 + 66/15 (f-1610)$	700Hz	
$1541 \leq f \leq 1608$	-75	1MHz	Averaged over any 2 millisecond active transmission interval
$1608 \leq f \leq 1610$	$-75 + 5/2 (f-1608)$	1MHz	
$1610 \leq f \leq 1627.5$	$-70 + 57/17.5 (f-1610)$	1MHz	
1627.5	-37	4kHz	
$1638.5 \leq f \leq 1645.5$	-28	4kHz	
$1657.5 \leq f \leq 1660.5$	-28	4kHz	
NOTE 1: The EIRP requirement in regulation is converted to conducted requirement using a 0 dBi antenna.			

6.6.3.3A Additional spurious emissions for CA

These requirements are specified in terms of an additional spectrum emission requirement. Additional spurious emission requirements are signalled by the network to indicate that the UE shall meet an additional requirement for a specific deployment scenario as part of the cell reconfiguration message.

NOTE: For measurement conditions at the edge of each frequency range, the lowest frequency of the measurement position in each frequency range should be set at the lowest boundary of the frequency range plus MBW/2. The highest frequency of the measurement position in each frequency range should be set at the highest boundary of the frequency range minus MBW/2. MBW denotes the measurement bandwidth defined for the protected band.

6.6.3.3A.1 Minimum requirement for CA_1C (network signalled value "CA_NS_01")

When "CA_NS_01" is indicated in the cell, the power of any UE emission shall not exceed the levels specified in Table 6.6.3.3A.1-1. This requirement also applies for the frequency ranges that are less than F_{OOB} (MHz) in Table 6.6.3.1A-1 from the edge of the aggregated channel bandwidth.

Table 6.6.3.3A.1-1: Additional requirements (PHS)

Protected band	Frequency range (MHz)			Maximum Level (dBm)	MBW (MHz)	Note
E-UTRA band 34	F_{DL_low}	-	F_{DL_high}	-50	1	
Frequency range	1884.5	-	1915.7	-41	0.3	1
NOTE 1: Applicable when the aggregated channel bandwidth is confined within frequency range 1940 – 1980 MHz						

6.6.3.3A.2 Minimum requirement for CA_1C (network signalled value "CA_NS_02")

When "CA_NS_02" is indicated in the cell, the power of any UE emission shall not exceed the levels specified in Table 6.6.3.3A.2-1. This requirement also applies for the frequency ranges that are less than F_{OOB} (MHz) in Table 6.6.3.1A-1 from the edge of the aggregated channel bandwidth.

Table 6.6.3.3A.2-1: Additional requirements

Protected band	Frequency range (MHz)			Maximum Level (dBm)	MBW (MHz)
E-UTRA band 34	F_{DL_low}	-	F_{DL_high}	-50	1
Frequency range	1900	-	1915	-15.5	5
Frequency range	1915	-	1920	+1.6	+1.6

6.6.3.3A.3 Minimum requirement for CA_1C (network signalled value "CA_NS_03")

When "CA_NS_03" is indicated in the cell, the power of any UE emission shall not exceed the levels specified in Table 6.6.3.3A.3-1. This requirement also applies for the frequency ranges that are less than F_{OOB} (MHz) in Table 6.6.3.1A-1 from the edge of the aggregated channel bandwidth.

Table 6.6.3.3A.3-1: Additional requirements

Protected band	Frequency range (MHz)			Maximum Level (dBm)	MBW (MHz)	Note
E-UTRA band 34	F_{DL_low}	-	F_{DL_high}	-50	1	
Frequency range	1880	-	1895	-40	1	
Frequency range	1895	-	1915	-15.5	5	1, 2
Frequency range	1915	-	1920	+1.6	5	1, 2
NOTE 1: The requirement also applies for the frequency ranges that are less than F_{OOB} (MHz) in Table 6.6.3.1A-1 and Table 6.6.3.1A-1 from the edge of the channel bandwidth.						
NOTE 2: For these adjacent bands, the emission limit could imply risk of harmful interference to UE(s) operating in the protected operating band						

6.6.3A Void

<reserved for future use>

6.6.3B Spurious emission for UL-MIMO

For UE supporting UL-MIMO, the requirements for Spurious emissions which are caused by unwanted transmitter effects such as harmonics emission, parasitic emissions, intermodulation products and frequency conversion products are specified at each transmit antenna connector.

For UEs with two transmit antenna connectors in closed-loop spatial multiplexing scheme, the requirements in subclause 6.6.3 apply to each transmit antenna connector. The requirements shall be met with the UL-MIMO configurations specified in Table 6.2.2B-1.

If UE is configured for transmission on single-antenna port, the requirements in subclause 6.6.3 apply.

6.6A Void

6.6B Void

6.7 Transmit intermodulation

The transmit intermodulation performance is a measure of the capability of the transmitter to inhibit the generation of signals in its non linear elements caused by presence of the wanted signal and an interfering signal reaching the transmitter via the antenna.

6.7.1 Minimum requirement

User Equipment(s) transmitting in close vicinity of each other can produce intermodulation products, which can fall into the UE, or eNode B receive band as an unwanted interfering signal. The UE intermodulation attenuation is defined by the ratio of the mean power of the wanted signal to the mean power of the intermodulation product when an interfering CW signal is added at a level below the wanted signal at each of the transmitter antenna port with the other antenna port(s) if any is terminated. Both the wanted signal power and the intermodulation product power are measured through E-UTRA rectangular filter with measurement bandwidth shown in Table 6.7.1-1.

The requirement of transmitting intermodulation is prescribed in Table 6.7.1-1.

Table 6.7.1-1: Transmit Intermodulation

BW Channel (UL)	5MHz		10MHz		15MHz		20MHz	
Interference Signal Frequency Offset	5MHz	10MHz	10MHz	20MHz	15MHz	30MHz	20MHz	40MHz
Interference CW Signal Level	-40dBc							
Intermodulation Product	-29dBc	-35dBc	-29dBc	-35dBc	-29dBc	-35dBc	-29dBc	-35dBc
Measurement bandwidth	4.5MHz	4.5MHz	9.0MHz	9.0MHz	13.5MHz	13.5MHz	18MHz	18MHz

6.7.1A Minimum requirement for CA

User Equipment(s) transmitting in close vicinity of each other can produce intermodulation products, which can fall into the UE, or eNode B receive band as an unwanted interfering signal. The UE intermodulation attenuation is defined by the ratio of the mean power of the wanted signal to the mean power of the intermodulation product on both component carriers when an interfering CW signal is added at a level below the wanted signal at each of the transmitter antenna port with the other antenna port(s) if any is terminated. Both the wanted signal power and the intermodulation product power are measured through rectangular filter with measurement bandwidth shown in Table 6.7.1A-1.

For intra-band contiguous carrier aggregation the requirement of transmitting intermodulation is specified in Table 6.7.1A-1.

Table 6.7.1A-1: Transmit Intermodulation

CA bandwidth class(UL)	C	
Interference Signal Frequency Offset	$BW_{\text{Channel_CA}}$	$2 * BW_{\text{Channel_CA}}$
Interference CW Signal Level	-40dBc	
Intermodulation Product	-29dBc	-35dBc
Measurement bandwidth	$BW_{\text{Channel_CA}} - 2 * BW_{\text{GB}}$	

6.7.1B Minimum requirement for UL-MIMO

For UE supporting UL-MIMO, the transmit intermodulation requirements are specified at each transmit antenna connector and the wanted signal is defined as the sum of output power at each transmit antenna connector.

For UEs with two transmit antenna connectors in closed-loop spatial multiplexing scheme, the requirements in subclause 6.7.1 apply to each transmit antenna connector. The requirements shall be met with the UL-MIMO configurations specified in Table 6.2.2B-2.

If UE is configured for transmission on single-antenna port, the requirements in subclause 6.7.1 apply.

6.8 Void

6.8.1 Void

6.8A Void

6.8B Time alignment error for UL-MIMO

For UE(s) with multiple transmit antenna connectors supporting UL-MIMO, this requirement applies to frame timing differences between transmissions on multiple transmit antenna connectors in the closed-loop spatial multiplexing scheme.

The time alignment error (TAE) is defined as the average frame timing difference between any two transmissions on different transmit antenna connectors.

6.8B.1 Minimum Requirements

For UE(s) with multiple transmit antenna connectors, the Time Alignment Error (TAE) shall not exceed 130 ns.

7 Receiver characteristics

7.1 General

Unless otherwise stated the receiver characteristics are specified at the antenna connector(s) of the UE. For UE(s) with an integral antenna only, a reference antenna(s) with a gain of 0 dBi is assumed for each antenna port(s). UE with an integral antenna(s) may be taken into account by converting these power levels into field strength requirements, assuming a 0 dBi gain antenna. . For UEs with more than one receiver antenna connector, identical interfering signals shall be applied to each receiver antenna port if more than one of these is used (diversity).

The levels of the test signal applied to each of the antenna connectors shall be as defined in the respective sections below.

With the exception of subclause 7.3, the requirements shall be verified with the network signalling value NS_01 configured (Table 6.2.4-1).

All the parameters in clause 7 are defined using the UL reference measurement channels specified in Annexes A.2.2 and A.2.3, the DL reference measurement channels specified in Annex A.3.2 and using the set-up specified in Annex C.3.1

7.2 Diversity characteristics

The requirements in Section 7 assume that the receiver is equipped with two Rx port as a baseline. These requirements apply to all UE categories unless stated otherwise. Requirements for 4 ports are FFS. With the exception of subclause 7.9 all requirements shall be verified by using both (all) antenna ports simultaneously.

7.3 Reference sensitivity power level

The reference sensitivity power level REFSSENS is the minimum mean power applied to both the UE antenna ports at which the throughput shall meet or exceed the requirements for the specified reference measurement channel.

7.3.1 Minimum requirements (QPSK)

The throughput shall be $\geq 95\%$ of the maximum throughput of the reference measurement channels as specified in Annexes A.2.2, A.2.3 and A.3.2 (with one sided dynamic OCNG Pattern OP.1 FDD/TDD for the DL-signal as described in Annex A.5.1.1/A.5.2.1) with parameters specified in Table 7.3.1-1 and Table 7.3.1-2

Table 7.3.1-1: Reference sensitivity QPSK P_{REFSENS}

E-UTRA Band	Channel bandwidth						Duplex Mode
	1.4 MHz (dBm)	3 MHz (dBm)	5 MHz (dBm)	10 MHz (dBm)	15 MHz (dBm)	20 MHz (dBm)	
1			-100	-97	-95.2	-94	FDD
2	-102.7	-99.7	-98	-95	-93.2	-92	FDD
3	-101.7	-98.7	-97	-94	-92.2	-91	FDD
4	-104.7	-101.7	-100	-97	-95.2	-94	FDD
5	-103.2	-100.2	-98	-95			FDD
6			-100	-97			FDD
7			-98	-95	-93.2	-92	FDD
8	-102.2	-99.2	-97	-94			FDD
9			-99	-96	-94.2	-93	FDD
10			-100	-97	-95.2	-94	FDD
11			-100	-97			FDD
12	-101.7	-98.7	-97	-94			FDD
13			-97	-94			FDD
14			-97	-94			FDD
...							
17			-97	-94			FDD
18			-100	-97	-95.2		FDD
19			-100	-97	-95.2		FDD
20			-97	-94	-91.2	-90	FDD
21			-100	-97	-95.2		FDD
22			-97	-94	-92.2	-91	FDD
23	-104.7	-101.7	-100	-97	-95.2	-94	FDD
24			-100	-97			FDD
25	-101.2	-98.2	-96.5	-93.5	-91.7	-90.5	FDD
...							
33			-100	-97	-95.2	-94	TDD
34			-100	-97	-95.2		TDD
35	-106.2	-102.2	-100	-97	-95.2	-94	TDD
36	-106.2	-102.2	-100	-97	-95.2	-94	TDD
37			-100	-97	-95.2	-94	TDD
38			-100	-97	-95.2	-94	TDD
39			-100	-97	-95.2	-94	TDD
40			-100	-97	-95.2	-94	TDD
41			-98	-95	-93.2	-92	TDD
42			-99	-96	-94.2	-93	TDD
43			-99	-96	-94.2	-93	TDD
NOTE 1: The transmitter shall be set to P_{UMAX} as defined in subclause 6.2.5							
NOTE 2: Reference measurement channel is A.3.2 with one sided dynamic OCNG Pattern OP.1 FDD/TDD as described in Annex A.5.1.1/A.5.2.1							
NOTE 3: The signal power is specified per port							
NOTE 4: For the UE which supports both Band 3 and Band 9 the reference sensitivity level is FFS.							
NOTE 5: For the UE which supports both Band 11 and Band 21 the reference sensitivity level is FFS.							

The reference receive sensitivity (REFSENS) requirement specified in Table 7.3.1-1 shall be met for an uplink transmission bandwidth less than or equal to that specified in Table 7.3.1-2.

NOTE: Table 7.3.1-2 is intended for conformance tests and does not necessarily reflect the operational conditions of the network, where the number of uplink and downlink allocated resource blocks will be practically constrained by other factors. Typical receiver sensitivity performance with HARQ retransmission enabled and using a residual BLER metric relevant for e.g. Speech Services is given in the Annex G (informative).

For the UE which supports inter-band carrier aggregation configuration in Table 7.3.1-1A with uplink in one E-UTRA band, the minimum requirement for reference sensitivity in Table 7.3.1-1 shall be increased by the amount given in $\Delta R_{IB,c}$ in Table 7.3.1-1A for the applicable E-UTRA bands.

Table 7.3.1-1A: $\Delta R_{IB,c}$

Inter-band CA Configuration	E-UTRA Band	$\Delta R_{IB,c}$ [dB]
CA_1A-5A	1	0
	5	0
<p>NOTE 1: The above additional tolerances are only applicable for the E-UTRA operating bands that belong to the supported inter-band carrier aggregation configurations</p> <p>NOTE 2: The above additional tolerances also apply in intra-band CA and non-aggregated operation for the supported E-UTRA operating bands that belong to the supported inter-band carrier aggregation configurations</p> <p>NOTE 3: In case the UE supports more than one of the above inter-band carrier aggregation configurations and a E-UTRA operating band belongs to more than one inter-band carrier aggregation configurations then:</p> <ul style="list-style-type: none"> - When the E-UTRA operating band frequency range is ≤ 1GHz, the applicable additional tolerance shall be the average of the tolerances in Table 7.3.1-1A, truncated to one decimal place that would apply for that operating band among the supported CA configurations. In case there is a harmonic relation between low band UL and high band DL, then the maximum tolerance among the different supported carrier aggregation configurations involving such band shall be applied - When the E-UTRA operating band frequency range is >1GHz, the applicable additional tolerance shall be the maximum tolerance in Table 7.3.1-1A that would apply for that operating band among the supported CA configurations 		

NOTE : The above additional tolerances do not apply to supported UTRA operating bands with frequency range below 1 GHz that correspond to the E-UTRA operating bands that belong to the supported inter-band carrier aggregation configurations when such bands are belonging only to band combination(s) where one band is <1 GHz and another band is >1.7 GHz and there is no harmonic relationship between the low band UL and high band DL. Otherwise the above additional tolerances also apply to supported UTRA operating bands that correspond to the E-UTRA operating bands that belong to the supported inter-band carrier aggregation configurations.

Table 7.3.1-2: Uplink configuration for reference sensitivity

E-UTRA Band / Channel bandwidth / N _{RB} / Duplex mode							
E-UTRA Band	1.4 MHz	3 MHz	5 MHz	10 MHz	15 MHz	20 MHz	Duplex Mode
1			25	50	75	100	FDD
2	6	15	25	50	50 ¹	50 ¹	FDD
3	6	15	25	50	50 ¹	50 ¹	FDD
4	6	15	25	50	75	100	FDD
5	6	15	25	25 ¹			FDD
6			25	25 ¹			FDD
7			25	50	75	75 ¹	FDD
8	6	15	25	25 ¹			FDD
9			25	50	50 ¹	50 ¹	FDD
10			25	50	75	100	FDD
11			25	25 ¹			FDD
12	6	15	20 ¹	20 ¹			FDD
13			20 ¹	20 ¹			FDD
14			15 ¹	15 ¹			FDD
...							
17			20 ¹	20 ¹			FDD
18			25	25 ¹	25 ¹		FDD
19			25	25 ¹	25 ¹		FDD
20			25	20 ¹	20 ³	20 ³	FDD
21			25	25 ¹	25 ¹		FDD
22			25	50	50 ¹	50 ¹	FDD
23	6	15	25	50	75	100	FDD
24			25	50			FDD
25	6	15	25	50	50 ¹	50 ¹	FDD
...							
33			25	50	75	100	TDD
34			25	50	75		TDD
35	6	15	25	50	75	100	TDD
36	6	15	25	50	75	100	TDD
37			25	50	75	100	TDD
38			25	50	75	100	TDD
39			25	50	75	100	TDD
40			25	50	75	100	TDD
41			25	50	75	100	TDD
42			25	50	75	100	TDD
43			25	50	75	100	TDD
NOTE 1: ¹ refers to the UL resource blocks shall be located as close as possible to the downlink operating band but confined within the transmission bandwidth configuration for the channel bandwidth (Table 5.6-1).							
NOTE 2: For the UE which supports both Band 11 and Band 21 the uplink configuration for reference sensitivity is FFS.							
NOTE 3: ³ refers to Band 20; in the case of 15MHz channel bandwidth, the UL resource blocks shall be located at RB _{start} 11 and in the case of 20MHz channel bandwidth, the UL resource blocks shall be located at RB _{start} 16							

Unless given by Table 7.3.1-3, the minimum requirements specified in Tables 7.3.1-1 and 7.3.1-2 shall be verified with the network signalling value NS_01 (Table 6.2.4-1) configured.

Table 7.3.1-3: Network signalling value for reference sensitivity

E-UTRA Band	Network Signalling value
2	NS_03
4	NS_03
10	NS_03
12	NS_06
13	NS_06
14	NS_06
17	NS_06
19	NS_08
21	NS_09
23	NS_03
25	NS_03

7.3.1A Minimum requirements (QPSK) for CA

For inter-band carrier aggregation with uplink assigned to one E-UTRA band the throughput shall be $\geq 95\%$ of the maximum throughput of the reference measurement channels as specified in Annexes A.2.2, A.2.3 and A.3.2 (with one sided dynamic OCNG Pattern OP.1 FDD/TDD for the DL-signal as described in Annex A.5.1.1/A.5.2.1) with parameters specified in Table 7.3.1-1 and Table 7.3.1-2. The reference sensitivity is defined to be met with both downlink component carriers active and either of the uplink carriers active. The uplink resource blocks shall be located as close as possible to the primary downlink operating band but confined within the transmission bandwidth configuration for the channel bandwidth (Table 5.6-1). The primary downlink operating band is the downlink band of the active uplink operating band. The UE shall meet the requirements specified in subclause 7.3.1.

For intra-band contiguous carrier aggregation the throughput of each component carrier shall be $\geq 95\%$ of the maximum throughput of the reference measurement channels as specified in Annexes A.2.2, A.2.3 and A.3.2 (with one sided dynamic OCNG Pattern OP.1 FDD/TDD for the DL-signal as described in Annex A.5.1.1/A.5.2.1) with parameters specified in Table 7.3.1-1 and Table 7.3.1A-1. Table 7.3.1A-1 specifies the maximum number of allocated uplink resource blocks for which the intra-band contiguous carrier aggregation reference sensitivity requirement shall be met. The PCC and SCC allocations as defined in Table 7.3.1A-1 form a contiguous allocation where TX–RX frequency separations of the component carriers are as defined in Table 5.7.4-1. For UE(s) supporting one uplink carrier, the uplink configuration of the PCC shall be in accordance with Table 7.3.1-2 and the downlink PCC carrier center frequency shall be configured closer to uplink operating band than the downlink SCC center frequency.

Table 7.3.1A-1: Intra-band CA uplink configuration for reference sensitivity

CA configuration / CC combination / N_{RB_agg} / Duplex mode							
Uplink CA configuration	100RB+50RB		75RB+75RB		100RB+100RB		Duplex Mode
	PCC	SCC	PCC	SCC	PCC	SCC	
CA_1C	N/A	N/A	75	54	100	30	FDD
CA_40C	100	50	75	75	100	100	TDD

NOTE 1: The carrier centre frequency of SCC in the UL operating band is configured closer to the DL operating band.
NOTE 2: The transmitted power over both PCC and SCC shall be set to P_{UMAX} as defined in subclause 6.2.5A.
NOTE 3: The UL resource blocks in both PCC and SCC shall be confined within the transmission bandwidth configuration for the channel bandwidth (Table 5.6-1).

7.3.1B Minimum requirements (QPSK) for UL-MIMO

For UE with two transmitter antenna connectors in closed-loop spatial multiplexing scheme, the minimum requirements in Clause 7.3.1 shall be met with the UL-MIMO configurations specified in Table 6.2.2B-2. For UL-MIMO, the parameter P_{UMAX} is the total transmitter power over the two transmit antenna connectors.

7.3.2 Void

7.4 Maximum input level

This is defined as the maximum mean power received at the UE antenna port, at which the specified relative throughput shall meet or exceed the minimum requirements for the specified reference measurement channel.

7.4.1 Minimum requirements

The throughput shall be $\geq 95\%$ of the maximum throughput of the reference measurement channels as specified in Annexes A.2.2, A.2.3 and A.3.2 (with one sided dynamic OCNG Pattern OP.1 FDD/TDD as described in Annex A.5.1.1/A.5.2.1) with parameters specified in Table 7.4.1-1

Table 7.4.1-1: Maximum input level

Rx Parameter	Units	Channel bandwidth					
		1.4 MHz	3 MHz	5 MHz	10 MHz	15 MHz	20 MHz
Power in Transmission Bandwidth Configuration	dBm	-25					
NOTE 1: The transmitter shall be set to 4dB below $P_{CMAX,L}$ at the minimum uplink configuration specified in Table 7.3.1-2 with $P_{CMAX,L}$ as defined in subclause 6.2.5.							
NOTE 2: Reference measurement channel is Annex A.3.2: 64QAM, R=3/4 variant with one sided dynamic OCNG Pattern OP.1 FDD/TDD as described in Annex A.5.1.1/A.5.2.1.							

7.4.1A Minimum requirements for CA

For inter-band carrier aggregation with uplink assigned to one E-UTRA band the maximum input level is defined with the uplink active on the band other than the band whose downlink is being tested. The UE shall meet the requirements specified in subclause 7.4.1 for each component carrier while both downlink carriers are active.

For intra-band contiguous carrier aggregation maximum input level is defined as the powers received at the UE antenna port over the Transmission bandwidth configuration of each CC, at which the specified relative throughput shall meet or exceed the minimum requirements for the specified reference measurement channel over each component carrier. The downlink SCC shall be configured at nominal channel spacing to the PCC with the PCC configured closest to the uplink band. Downlink PCC and SCC are both activated. The uplink output power shall be set as specified in Table 7.4.1A-1 with the uplink configuration set according to Table 7.3.1A-1 for the applicable carrier aggregation configuration. For UE(s) supporting one uplink carrier, the uplink configuration of the PCC shall be in accordance with Table 7.3.1-2.

The throughput shall be $\geq 95\%$ of the maximum throughput of the reference measurement channels over each component carrier as specified in Annexes A.2.2, A.2.3 and A.3.2 (with one sided dynamic OCNG Pattern OP.1 FDD/TDD as described in Annex A.5.1.1/A.5.2.1) with parameters specified in Table 7.4.1A-1.

Table 7.4.1A-1: Maximum input level for intra-band contiguous CA

Rx Parameter	Units	CA Bandwidth Class					
		A	B	C	D	E	F
Power in largest Transmission Bandwidth Configuration CC	dBm			-25			
Power in each other CC	dBm			$-25 + 10\log(N_{RB,c} / N_{RB,largest\ BW})$			
NOTE 1: The transmitter shall be set to 4dB below P_{CMAX_L} or $P_{CMAX_L_CA}$ as defined in subclause 6.2.5A.							
NOTE 2: Reference measurement channel is Annex A.3.2: 64QAM, R=3/4 variant with one sided dynamic OCNG Pattern OP.1 FDD/TDD as described in Annex A.5.1.1/A.5.2.1.							

7.4.1B Minimum requirements for UL-MIMO

For UE with two transmitter antenna connectors in closed-loop spatial multiplexing, the minimum requirements in Clause 7.4.1 shall be met with the UL-MIMO configurations specified in Table 6.2.2B-2. For UL-MIMO, the parameter P_{CMAX_L} is defined as the total transmitter power over the two transmit antenna connectors.

7.4A Void

7.4A.1 Void

7.5 Adjacent Channel Selectivity (ACS)

Adjacent Channel Selectivity (ACS) is a measure of a receiver's ability to receive a E-UTRA signal at its assigned channel frequency in the presence of an adjacent channel signal at a given frequency offset from the centre frequency of the assigned channel. ACS is the ratio of the receive filter attenuation on the assigned channel frequency to the receive filter attenuation on the adjacent channel(s).

7.5.1 Minimum requirements

The UE shall fulfil the minimum requirement specified in Table 7.5.1-1 for all values of an adjacent channel interferer up to -25 dBm. However it is not possible to directly measure the ACS, instead the lower and upper range of test parameters are chosen in Table 7.5.1-2 and Table 7.5.1-3 where the throughput shall be $\geq 95\%$ of the maximum throughput of the reference measurement channels as specified in Annexes A.2.2, A.2.3 and A.3.2 (with one sided dynamic OCNG Pattern OP.1 FDD/TDD for the DL-signal as described in Annex A.5.1.1/A.5.2.1).

Table 7.5.1-1: Adjacent channel selectivity

Rx Parameter	Units	Channel bandwidth					
		1.4 MHz	3 MHz	5 MHz	10 MHz	15 MHz	20 MHz
ACS	dB	33	33	33	33	30	27

Table 7.5.1-2: Test parameters for Adjacent channel selectivity, Case 1

Rx Parameter	Units	Channel bandwidth					
		1.4 MHz	3 MHz	5 MHz	10 MHz	15 MHz	20 MHz
Power in Transmission Bandwidth Configuration	dBm	REFSENS + 14 dB					
$P_{\text{Interferer}}$	dBm	REFSENS +45.5dB	REFSENS +45.5dB	REFSENS +45.5dB	REFSENS +45.5dB	REFSENS +42.5dB	REFSENS +39.5dB
$BW_{\text{Interferer}}$	MHz	1.4	3	5	5	5	5
$F_{\text{Interferer}}$ (offset)	MHz	1.4+0.0025 / -1.4-0.0025	3+0.0075 / -3-0.0075	5+0.0025 / -5-0.0025	7.5+0.0075 / -7.5-0.0075	10+0.0125 / -10-0.0125	12.5+0.0025 / -12.5-0.0025
NOTE 1: The transmitter shall be set to 4dB below $P_{\text{CMAX_L}}$ at the minimum uplink configuration specified in Table 7.3.1-2 with $P_{\text{CMAX_L}}$ as defined in subclause 6.2.5.							
NOTE 2: The interferer consists of the Reference measurement channel specified in Annex A.3.2 with one sided dynamic OCNG Pattern OP.1 FDD/TDD as described in Annex A.5.1.1/A.5.2.1 and set-up according to Annex C.3.1							

Table 7.5.1-3: Test parameters for Adjacent channel selectivity, Case 2

Rx Parameter	Units	Channel bandwidth					
		1.4 MHz	3 MHz	5 MHz	10 MHz	15 MHz	20 MHz
Power in Transmission Bandwidth Configuration	dBm	-56.5	-56.5	-56.5	-56.5	-53.5	-50.5
$P_{\text{Interferer}}$	dBm	-25					
$BW_{\text{Interferer}}$	MHz	1.4	3	5	5	5	5
$F_{\text{Interferer}}$ (offset)	MHz	1.4+0.0025 / -1.4-0.0025	3+0.0075 / -3-0.0075	5+0.0025 / -5-0.0025	7.5+0.0075 / -7.5-0.0075	10+0.0125 / -10-0.0125	12.5+0.0025 / -12.5-0.0025
NOTE 1: The transmitter shall be set to 24dB below $P_{\text{CMAX_L}}$ at the minimum uplink configuration specified in Table 7.3.1-2 with $P_{\text{CMAX_L}}$ as defined in subclause 6.2.5.							
NOTE 2: The interferer consists of the Reference measurement channel specified in Annex 3.2 with one sided dynamic OCNG Pattern OP.1 FDD/TDD as described in Annex A.5.1.1/A.5.2.1 and set-up according to Annex C.3.1							

7.5.1A Minimum requirements for CA

For inter-band carrier aggregation with uplink assigned to one E-UTRA band, the adjacent channel requirements are defined with the uplink active on the band other than the band whose downlink is being tested. The UE shall meet the requirements specified in subclause 7.5.1 for each component carrier while both downlink carriers are active.

For intra-band contiguous carrier aggregation the downlink SCC shall be configured at nominal channel spacing to the PCC with the PCC configured closest to the uplink band. Downlink PCC and SCC are both activated. The uplink output power shall be set as specified in Table 7.5.1A-2 or 7.5.1A-3 with the uplink configuration set according to Table 7.3.1A-1 for the applicable carrier aggregation configuration. For UE(s) supporting one uplink carrier, the uplink configuration of the PCC shall be in accordance with Table 7.3.1-2. The UE shall fulfil the minimum requirement specified in Table 7.5.1A-1 for an adjacent channel interferer on either side of the aggregated downlink signal at a specified frequency offset and for an interferer power up to -25 dBm. The throughput of each carrier shall be $\geq 95\%$ of the maximum throughput of the reference measurement channels as specified in Annexes A.2.2, A.2.3 and A.3.2 (with one sided dynamic OCNG Pattern OP.1 FDD/TDD for the DL-signal as described in Annex A.5.1.1/A.5.2.1) with parameters specified in Tables 7.5.1A-2 and 7.5.1A-3.

Table 7.5.1A-1: Adjacent channel selectivity

Rx Parameter	Units	CA Bandwidth Class				
		B	C	D	E	F
ACS	dB		24			

Table 7.5.1A-2: Test parameters for Adjacent channel selectivity, Case 1

Rx Parameter	Units	CA Bandwidth Class				
		B	C	D	E	F
P _w in Transmission Bandwidth Configuration, per CC			REFSENS + 14 dB			
P _{Interferer}	dBm		Aggregated power + 22.5 dB			
BW _{Interferer}	MHz		5			
F _{Interferer} (offset)	MHz		2.5 + F _{offset} / -2.5 - F _{offset}			
NOTE 1: The transmitter shall be set to 4dB below P _{CMAX_L,c} or P _{CMAX_L} as defined in subclause 6.2.5A.						
NOTE 2: The interferer consists of the Reference measurement channel specified in Annex A.3.2 with one sided dynamic OCNG Pattern OP.1 FDD/TDD as described in Annex A.5.1.1/A.5.2.1 and set-up according to Annex C.3.1						
NOTE 3: The F _{interferer} (offset) is the frequency separation of the center frequency of the carrier closest to the interferer and the center frequency of the adjacent channel interferer and shall be further adjusted to $\lfloor F_{interferer} / 0.015 + 0.5 \rfloor 0.015 + 0.0075$ MHz to be offset from the sub-carrier raster.						

Table 7.5.1 A-3: Test parameters for Adjacent channel selectivity, Case 2

Rx Parameter	Units	CA Bandwidth Class				
		B	C	D	E	F
P _w in Transmission Bandwidth Configuration, per CC	dBm		-47.5+10 log ₁₀ (N _{RB,c} / N _{RB agg})			
P _{Interferer}	dBm			-25		
BW _{Interferer}	MHz		5			
F _{Interferer} (offset)	MHz		2.5+ F _{offset} / -2.5- F _{offset}			
NOTE 1: The transmitter shall be set to 24dB below P _{CMAX_L,c} or P _{CMAX_L} as defined in subclause 6.2.5A.						
NOTE 2: The interferer consists of the Reference measurement channel specified in Annex 3.2 with one sided dynamic OCNG Pattern OP.1 FDD/TDD as described in Annex A.5.1.1/A.5.2.1 and set-up according to Annex C.3.1						
NOTE 3: The F _{interferer} (offset) is the frequency separation of the center frequency of the carrier closest to the interferer and the center frequency of the adjacent channel interferer and shall be further adjusted to $\lfloor F_{interferer} / 0.015 + 0.5 \rfloor 0.015 + 0.0075$ MHz to be offset from the sub-carrier raster.						

7.5.1B Minimum requirements for UL-MIMO

For UE(s) with two transmitter antenna connectors in closed-loop spatial multiplexing scheme, the minimum requirements in Clause 7.5.1 shall be met with the UL-MIMO configurations specified in Table 6.2.2B-2. For UL-MIMO, the parameter P_{CMAX_L} is defined as the total transmitter power over the two transmit antenna connectors.

7.6 Blocking characteristics

The blocking characteristic is a measure of the receiver's ability to receive a wanted signal at its assigned channel frequency in the presence of an unwanted interferer on frequencies other than those of the spurious response or the adjacent channels, without this unwanted input signal causing a degradation of the performance of the receiver beyond a specified limit. The blocking performance shall apply at all frequencies except those at which a spurious response occur.

7.6.1 In-band blocking

In-band blocking is defined for an unwanted interfering signal falling into the UE receive band or into the first 15 MHz below or above the UE receive band at which the relative throughput shall meet or exceed the minimum requirement for the specified measurement channels..

7.6.1.1 Minimum requirements

The throughput shall be $\geq 95\%$ of the maximum throughput of the reference measurement channels as specified in Annexes A.2.2, A.2.3 and A.3.2 (with one sided dynamic OCNB Pattern OP.1 FDD/TDD for the DL-signal as described in Annex A.5.1.1/A.5.2.1) with parameters specified in Tables 7.6.1.1-1 and 7.6.1.1-2.

Table 7.6.1.1-1: In band blocking parameters

Rx parameter	Units	Channel bandwidth					
		1.4 MHz	3 MHz	5 MHz	10 MHz	15 MHz	20 MHz
Power in Transmission Bandwidth Configuration	dBm	REFSENS + channel bandwidth specific value below					
		6	6	6	6	7	9
BW _{Interferer}	MHz	1.4	3	5	5	5	5
F _{offset, case 1}	MHz	2.1+0.0125	4.5+0.0075	7.5+0.0125	7.5+0.0025	7.5+0.0075	7.5+0.0125
F _{offset, case 2}	MHz	3.5+0.0075	7.5+0.0075	12.5+0.0075	12.5+0.0125	12.5+0.0025	12.5+0.0075
NOTE 1: The transmitter shall be set to 4dB below P _{CMAX,L} at the minimum uplink configuration specified in Table 7.3.1-2 with P _{CMAX,L} as defined in subclause 6.2.5.							
NOTE 2: The interferer consists of the Reference measurement channel specified in Annex A.3.2 with one sided dynamic OCNB Pattern OP.1 FDD/TDD as described in Annex A.5.1.1/A.5.2.1 and set-up according to Annex C.3.1							

Table 7.6.1.1-2: In-band blocking

E-UTRA band	Parameter	Unit	Case 1	Case 2	Case 3	Case 4
		P _{Interferer}	dBm	-56	-44	Void
	F _{Interferer (offset)}	MHz	$=-BW/2 - F_{offset, case 1}$ & $=+BW/2 + F_{offset, case 1}$	$\leq -BW/2 - F_{offset, case 2}$ & $\geq +BW/2 + F_{offset, case 2}$		
1, 2, 3, 4, 5, 6, 7, 8, 9, 10, 11, 12, 13, 14, 17, 18, 19, 20, 21, 22, 23, 25, 33, 34, 35, 36, 37, 38, 39, 40, 41, 42, 43	F _{Interferer}	MHz	(Note 2)	F _{DL_low} - 15 to F _{DL_high} + 15		
NOTE 1: For certain bands, the unwanted modulated interfering signal may not fall inside the UE receive band, but within the first 15 MHz below or above the UE receive band						
NOTE 2: For each carrier frequency the requirement is valid for two frequencies: a. the carrier frequency $-BW/2 - F_{offset, case 1}$ and b. the carrier frequency $+BW/2 + F_{offset, case 1}$						
NOTE 3: F _{Interferer} range values for unwanted modulated interfering signal are interferer center frequencies.						

For the UE which supports inter band CA configuration in Table 7.3.1-1A, P_{Interferer} power defined in Table 7.6.1.1-2 is increased by the amount given by $\Delta R_{IB,c}$ in Table 7.3.1-1A.

7.6.1.1A Minimum requirements for CA

For inter-band carrier aggregation with uplink assigned to one E-UTRA band the in-band blocking requirements are defined with the uplink active on the band other than the band whose downlink is being tested. The UE shall meet the

requirements specified in subclause 7.6.1.1 for each component carrier while both downlink carriers are active. For the UE which supports inter band CA configuration in Table 7.3.1-1A, $P_{\text{Interferer}}$ power defined in Table 7.6.1.1-2 is increased by the amount given by $\Delta R_{\text{IB,c}}$ in Table 7.3.1-1A.

For intra-band contiguous carrier aggregation the downlink SCC shall be configured at nominal channel spacing to the PCC with the PCC configured closest to the uplink band. Downlink PCC and SCC are both activated. The uplink output power shall be set as specified in Table 7.6.1.1A-1 with the uplink configuration set according to Table 7.3.1A-1 for the applicable carrier aggregation configuration. For UE(s) supporting one uplink carrier, the uplink configuration of the PCC shall be in accordance with Table 7.3.1-2. The UE shall fulfil the minimum requirement in presence of an interfering signal specified in Tables 7.6.1.1A-1 and Tables 7.6.1.1A-2 being on either side of the aggregated signal. The throughput of each carrier shall be $\geq 95\%$ of the maximum throughput of the reference measurement channels as specified in Annexes A.2.2, A.2.3 and A.3.2 (with one sided dynamic OCNG Pattern OP.1 FDD/TDD for the DL-signal as described in Annex A.5.1.1/A.5.2.1) with parameters specified in Tables 7.6.1.1A-1 and 7.6.1.1A-2.

Table 7.6.1.1A-1: In band blocking parameters

Rx Parameter	Units	CA Bandwidth Class				
		B	C	D	E	F
Pw in Transmission Bandwidth Configuration, per CC	dBm	REFSENS + CA Bandwidth Class specific value below				
			12			
$BW_{\text{Interferer}}$	MHz		5			
$F_{\text{offset, case 1}}$	MHz		7.5			
$F_{\text{offset, case 2}}$	MHz		12.5			
NOTE 1: The transmitter shall be set to 4dB below $P_{\text{CMAX,L,c}}$ or $P_{\text{CMAX,L}}$ as defined in subclause 6.2.5A						
NOTE 2: The interferer consists of the Reference measurement channel specified in Annex A.3.2 with one sided dynamic OCNG Pattern OP.1 FDD/TDD as described in Annex A.5.1.1/A.5.2.1 and set-up according to Annex C.3.1						

Table 7.6.1.1A-2: In-band blocking

CA configuration	Parameter	Unit	Case 1	Case 2
		$P_{\text{Interferer}}$	dBm	-56
	$F_{\text{Interferer}}$ (offset)	MHz	$=-F_{\text{offset}} - F_{\text{offset, case 1}}$ & $=+F_{\text{offset}} + F_{\text{offset, case 1}}$	$\leq -F_{\text{offset}} - F_{\text{offset, case 2}}$ & $\geq +F_{\text{offset}} + F_{\text{offset, case 2}}$
CA_1C, CA_40C	$F_{\text{Interferer}}$ (Range)	MHz	(Note 2)	$F_{\text{DL,low}} - 15$ to $F_{\text{DL,high}} + 15$
NOTE 1: For certain bands, the unwanted modulated interfering signal may not fall inside the UE receive band, but within the first 15 MHz below or above the UE receive band				
NOTE 2: For each carrier frequency the requirement is valid for two frequencies: a. the carrier frequency - $F_{\text{offset}} - F_{\text{offset, case 1}}$ and b. the carrier frequency + $F_{\text{offset}} + F_{\text{offset, case 1}}$				
NOTE 3: F_{offset} is the frequency offset from the center frequency of the CC being tested to the edge of aggregated channel bandwidth.				
NOTE 4: The $F_{\text{interferer}}$ (offset) is the frequency separation of the center frequency of the carrier closest to the interferer and the center frequency of the interferer and shall be further adjusted to $\lfloor F_{\text{interferer}} / 0.015 + 0.5 \rfloor 0.015 + 0.0075$ MHz to be offset from the sub-carrier raster.				

7.6.2 Out-of-band blocking

Out-of-band band blocking is defined for an unwanted CW interfering signal falling more than 15 MHz below or above the UE receive band. For the first 15 MHz below or above the UE receive band the appropriate in-band blocking or adjacent channel selectivity in subclause 7.5.1 and subclause 7.6.1 shall be applied.

7.6.2.1 Minimum requirements

The throughput shall be $\geq 95\%$ of the maximum throughput of the reference measurement channels as specified in Annexes A.2.2, A.2.3 and A.3.2 (with one sided dynamic OCNG Pattern OP.1 FDD/TDD for the DL-signal as described in Annex A.5.1.1/A.5.2.1) with parameters specified in Tables 7.6.2.1-1 and 7.6.2.1-2.

For Table 7.6.2.1-2 in frequency range 1, 2 and 3, up to $\max(24, 6 \cdot \lceil N_{RB} / 6 \rceil)$ exceptions are allowed for spurious response frequencies in each assigned frequency channel when measured using a 1MHz step size, where N_{RB} is the number of resource blocks in the downlink transmission bandwidth configuration (see Figure 5.6-1). For these exceptions the requirements of subclause 7.7 Spurious response are applicable.

For Table 7.6.2.1-2 in frequency range 4, up to $\max(8, \lceil (N_{RB} + 2 \cdot L_{CRBs}) / 8 \rceil)$ exceptions are allowed for spurious response frequencies in each assigned frequency channel when measured using a 1MHz step size, where N_{RB} is the number of resource blocks in the downlink transmission bandwidth configurations (see Figure 5.6-1) and L_{CRBs} is the number of resource blocks allocated in the uplink. For these exceptions the requirements of clause 7.7 spurious response are applicable.

Table 7.6.2.1-1: Out-of-band blocking parameters

Rx Parameter	Units	Channel bandwidth					
		1.4 MHz	3 MHz	5 MHz	10 MHz	15 MHz	20 MHz
Power in Transmission Bandwidth Configuration	dBm	REFSENS + channel bandwidth specific value below					
		6	6	6	6	7	9
NOTE 1: The transmitter shall be set to 4dB below P_{CMAX_L} at the minimum uplink configuration specified in Table 7.3.1-2 with P_{CMAX_L} as defined in subclause 6.2.5.							
NOTE 2: Reference measurement channel is specified in Annex A.3.2 with one sided dynamic OCNG Pattern OP.1 FDD/TDD as described in Annex A.5.1.1/A.5.2.							

Table 7.6.2.1-2: Out of band blocking

E-UTRA band	Parameter	Units	Frequency			
			range 1	range 2	range 3	range 4
	$P_{Interferer}$	dBm	-44	-30	-15	-15
1, 2, 3, 4, 5 6, 7, 8, 9, 10, 11, 12, 13, 14, 17, 18, 19, 20, 21, 22, 23, 24, 25, 33, 34, 35, 36, 37, 38, 39, 40, 41, 42 (NOTE 2), 43 (NOTE 2)	$F_{Interferer}$ (CW)	MHz	$F_{DL_low} -15$ to $F_{DL_low} -60$	$F_{DL_low} -60$ to $F_{DL_low} -85$	$F_{DL_low} -85$ to 1 MHz	-
			$F_{DL_high} +15$ to $F_{DL_high} + 60$	$F_{DL_high} +60$ to $F_{DL_high} +85$	$F_{DL_high} +85$ to +12750 MHz	-
2, 5, 12, 17	$F_{Interferer}$	MHz	-	-	-	$F_{UL_low} - F_{UL_high}$
NOTE 1: For the UE which supports both Band 11 and Band 21 the out of blocking is FFS.						
NOTE 2: The power level of the interferer ($P_{Interferer}$) for Range 3 shall be modified to -20 dBm for $F_{Interferer} > 2800$ MHz and $F_{Interferer} < 4400$ MHz.						

7.6.2.1A Minimum requirements for CA

For inter-band carrier aggregation with the uplink assigned to one E-UTRA band, the out-of-band blocking requirements are defined with the uplink active on the band other than the band whose downlink is being tested. The throughput in the downlink measured shall be $\geq 95\%$ of the maximum throughput of the reference measurement channels as specified in Annexes A.2.2, A.2.3 and A.3.2 (with one sided dynamic OCNG Pattern OP.1 FDD/TDD for

the DL-signal as described in Annex A.5.1.1/A.5.2.1) with parameters specified in Tables 7.6.2.1-1 and 7.6.2.1A-0. The UE shall meet these requirements for each component carrier while both downlink carriers are active.

Table 7.6.2.1A-0: out-of-band blocking for inter-band carrier aggregation with one active uplink

Parameter	Unit	Range 1	Range 2	Range 3
P_w	dBm	Table 7.6.2.1-1 for both component carriers		
$P_{interferer}$	dBm	$-44 + \Delta R_{IB,c}$	$-30 + \Delta R_{IB,c}$	$-15 + \Delta R_{IB,c}$
$F_{interferer}$ (CW)	MHz	$-60 < f - F_{DL_Low(1)} < -15$ or $-60 < f - F_{DL_Low(2)} < -15$ or $15 < f - F_{DL_High(1)} < 60$ or $15 < f - F_{DL_High(2)} < 60$	$-85 < f - F_{DL_Low(1)} \leq -60$ or $-85 < f - F_{DL_Low(2)} \leq -60$ or $60 \leq f - F_{DL_High(1)} < 85$ or $60 \leq f - F_{DL_High(2)} < 85$	$1 \leq f \leq F_{DL_Low(1)} - 85$ or $F_{DL_High(1)} + 85 \leq f \leq F_{DL_Low(2)} - 85$ or $F_{DL_High(2)} + 85 \leq f \leq 12750$
NOTE 1: $F_{DL_Low(1)}$ and $F_{DL_High(1)}$ denote the respective lower and upper frequency limits of the lower operating band, $F_{DL_Low(2)}$ and $F_{DL_High(2)}$ the respective lower and upper frequency limits of the upper operating band. NOTE 2: For $F_{DL_Low(2)} - F_{DL_High(1)} < 145$ MHz and $F_{interferer}$ in $F_{DL_High(1)} < f < F_{DL_Low(2)}$, $F_{interferer}$ can be in both Range 1 and Range 2. Then the lower of the $P_{interferer}$ applies. NOTE 3: For $F_{DL_Low(1)} - 15$ MHz $\leq f \leq F_{DL_High(1)} + 15$ MHz and $F_{DL_Low(2)} - 15$ MHz $\leq f \leq F_{DL_High(2)} + 15$ MHz the appropriate adjacent channel selectivity and in-band blocking in the respective subclauses 7.5.1A and 7.6.1.1A shall be applied. NOTE 4: $\Delta R_{IB,c}$ according to Table 7.3.1-1A applies when serving cell c is measured.				

For Table 7.6.2.1A-0 in frequency ranges 1, 2 and 3, up to $\max(24,6 \cdot \lceil N_{RB} / 6 \rceil)$ exceptions per downlink are allowed for spurious response frequencies when measured using a step size of 1 MHz. For these exceptions the requirements in clause 7.7.1A apply.

For intra-band contiguous carrier aggregations the downlink SCC shall be configured at nominal channel spacing to the PCC with the PCC configured closest to the uplink band. Downlink PCC and SCC are both activated. The uplink output power shall be set as specified in Table 7.6.2.1A-1 with the uplink configuration set according to Table 7.3.1A-1 for the applicable carrier aggregation configuration. For UE(s) supporting one uplink carrier, the uplink configuration of the PCC shall be in accordance with Table 7.3.1-2.

The UE shall fulfil the minimum requirement in presence of an interfering signal specified in Tables 7.6.2.1A-1 and Tables 7.6.2.1A-2 being on either side of the aggregated signal. The throughput of each carrier shall be $\geq 95\%$ of the maximum throughput of the reference measurement channels as specified in Annexes A.2.2, A.2.3 and A.3.2 (with one sided dynamic OCNG Pattern OP.1 FDD/TDD for the DL-signal as described in Annex A.5.1.1/A.5.2.1) with parameters specified in Tables 7.6.2.1A-1 and 7.6.2.1A-2.

For Table 7.6.2.1A-2 in frequency range 1, 2 and 3, up to $\max(24,6 \cdot \lceil N_{RB} / 6 \rceil)$ exceptions are allowed for spurious response frequencies in each assigned frequency channel when measured using a 1MHz step size. For these exceptions the requirements of subclause 7.7 Spurious response are applicable.

Table 7.6.2.1A-1: Out-of-band blocking parameters

Rx Parameter	Units	CA Bandwidth Class				
		B	C	D	E	F
P_w in Transmission Bandwidth Configuration, per CC	dBm	REFSENS + CA Bandwidth Class specific value below				
			9			
NOTE 1: The transmitter shall be set to 4dB below $P_{C_{MAX,L,c}}$ or $P_{C_{MAX,L}}$ as defined in subclause 6.2.5A.						
NOTE 2: Reference measurement channel is specified in Annex A.3.2 with one sided dynamic OCNG Pattern OP.1 FDD/TDD as described in Annex A.5.1.1/A.5.2.						

Table 7.6.2.1A-2: Out of band blocking

CA configuration	Parameter	Units	Frequency		
			Range 1	Range 2	Range 3
	$P_{\text{Interferer}}$	dBm	-44	-30	-15
CA_1C, CA_40C	$F_{\text{Interferer}} \text{ (CW)}$	MHz	$F_{\text{DL_low}} -15$ to $F_{\text{DL_low}} -60$	$F_{\text{DL_low}} -60$ to $F_{\text{DL_low}} -85$	$F_{\text{DL_low}} -85$ to 1 MHz
			$F_{\text{DL_high}} +15$ to $F_{\text{DL_high}} +60$	$F_{\text{DL_high}} +60$ to $F_{\text{DL_high}} +85$	$F_{\text{DL_high}} +85$ to +12750 MHz

7.6.3 Narrow band blocking

This requirement is measure of a receiver's ability to receive a E-UTRA signal at its assigned channel frequency in the presence of an unwanted narrow band CW interferer at a frequency, which is less than the nominal channel spacing.

7.6.3.1 Minimum requirements

The relative throughput shall be $\geq 95\%$ of the maximum throughput of the reference measurement channels as specified in Annexes A.2.2, A.2.3 and A.3.2 (with one sided dynamic OCNG Pattern OP.1 FDD/TDD for the DL-signal as described in Annex A.5.1.1/A.5.2.1) with parameters specified in Table 7.6.3.1-1

Table 7.6.3.1-1: Narrow-band blocking

Parameter	Unit	Channel Bandwidth					
		1.4 MHz	3 MHz	5 MHz	10 MHz	15 MHz	20 MHz
P_w	dBm	P_{REFSENS} + channel-bandwidth specific value below					
$P_{\text{UW}} \text{ (CW)}$	dBm	22	18	16	13	14	16
$F_{\text{UW}} \text{ (offset for } \Delta f = 15 \text{ kHz)}$	MHz	0.9075	1.7025	2.7075	5.2125	7.7025	10.2075
$F_{\text{UW}} \text{ (offset for } \Delta f = 7.5 \text{ kHz)}$	MHz						
NOTE 1: The transmitter shall be set a 4 dB below $P_{\text{CMAX_L}}$ at the minimum uplink configuration specified in Table 7.3.1-2 with $P_{\text{CMAX_L}}$ as defined in subclause 6.2.5.							
NOTE 2: Reference measurement channel is specified in Annex A.3.2 with one sided dynamic OCNG Pattern OP.1 FDD/TDD as described in Annex A.5.1.1/A.5.2.1.							

For the UE which supports inter-band CA configuration in Table 7.3.1-1A, P_{UW} power defined in Table 7.6.3.1-1 is increased by the amount given by $\Delta R_{\text{IB,c}}$ in Table 7.3.1-1A.

7.6.3.1A Minimum requirements for CA

For inter-band carrier aggregation with uplink assigned to one E-UTRA band the narrow-band blocking requirements are defined with the uplink active on the band other than the band whose downlink is being tested. The UE shall meet the requirements specified in subclause 7.6.3.1 for each component carrier while both downlink carriers are active.

For intra-band contiguous carrier aggregation the downlink SCC shall be configured at nominal channel spacing to the PCC with the PCC configured closest to the uplink band. Downlink PCC and SCC are both activated. The uplink output power shall be set as specified in Table 7.6.3.1A-1 with the uplink configuration set according to Table 7.3.1A-1 for the applicable carrier aggregation configuration. For UE(s) supporting one uplink, the uplink configuration of the PCC shall be in accordance with Table 7.3.1-2. The UE shall fulfil the minimum requirement in presence of an interfering signal specified in Table 7.6.3.1A-1 being on either side of the aggregated signal. The throughput of each carrier shall be $\geq 95\%$ of the maximum throughput of the reference measurement channels as specified in Annexes A.2.2, A.2.3 and A.3.2 (with one sided dynamic OCNG Pattern OP.1 FDD/TDD for the DL-signal as described in Annex A.5.1.1/A.5.2.1) with parameters specified in Table 7.6.3.1A-1.

Table 7.6.3.1A-1: Narrow-band blocking

Parameter	Unit	CA Bandwidth Class				
		B	C	D	E	F
P _w in Transmission Bandwidth Configuration, per CC	dBm	REFSENS + CA Bandwidth Class specific value below				
			16 ⁴			
P _{uw} (CW)	dBm		-55			
F _{uw} (offset for Δf = 15 kHz)		MHz		- F _{offset} - 0.2 / + F _{offset} + 0.2		
F _{uw} (offset for Δf = 7.5 kHz)	MHz					
NOTE 1: The transmitter shall be set to 4dB below P _{C_{MAX}L,c} or P _{C_{MAX}L} as defined in subclause 6.2.5A.						
NOTE 2: Reference measurement channel is specified in Annex A.3.2 with one sided dynamic OCNG Pattern OP.1 FDD/TDD as described in Annex A.5.1.1/A.5.2.1.						
NOTE 3: The F _{uw} (offset) is the frequency separation of the center frequency of the carrier closest to the interferer and the center frequency of the interferer and shall be further adjusted to $\lfloor F_{\text{interferer}} / 0.015 + 0.5 \rfloor 0.015 + 0.0075$ MHz to be offset from the sub-carrier raster.						
NOTE 4: The requirement is applied for the band combinations whose component carriers' BW ≥ 5 MHz.						

7.6A Void

<Reserved for future use>

7.6B Blocking characteristics for UL-MIMO

For UE with two transmitter antenna connectors in closed-loop spatial multiplexing scheme, the minimum requirements in subclause 7.6 shall be met with the UL-MIMO configurations specified in Table 6.2.2B-2. For UL-MIMO, the parameter P_{C_{MAX}L} is defined as the total transmitter power over the two transmit antenna connectors.

7.7 Spurious response

Spurious response is a measure of the receiver's ability to receive a wanted signal on its assigned channel frequency without exceeding a given degradation due to the presence of an unwanted CW interfering signal at any other frequency at which a response is obtained i.e. for which the out of band blocking limit as specified in subclause 7.6.2 is not met.

7.7.1 Minimum requirements

The throughput shall be ≥ 95% of the maximum throughput of the reference measurement channels as specified in Annexes A.2.2, A.2.3 and A.3.2 (with one sided dynamic OCNG Pattern OP.1 FDD/TDD for the DL-signal as described in Annex A.5.1.1/A.5.2.1) with parameters specified in Tables 7.7.1-1 and 7.7.1-2.

Table 7.7.1-1: Spurious response parameters

Rx parameter	Units	Channel bandwidth					
		1.4 MHz	3 MHz	5 MHz	10 MHz	15 MHz	20 MHz
Power in Transmission Bandwidth Configuration	dBm	REFSENS + channel bandwidth specific value below					
		6	6	6	6	7	9
NOTE 1: The transmitter shall be set to 4dB below P _{C_{MAX}L} at the minimum uplink configuration specified in Table 7.3.1-2.							
NOTE 2: Reference measurement channel is specified in Annex A.3.2 with one sided dynamic OCNG Pattern OP.1 FDD/TDD as described in Annex A.5.1.1/A.5.2.1.							

Table 7.7.1-2: Spurious response

Parameter	Unit	Level
$P_{\text{Interferer}}$ (CW)	dBm	-44
$F_{\text{Interferer}}$	MHz	Spurious response frequencies

For the UE which supports inter-band CA configuration in Table 7.3.1-1A, $P_{\text{interferer}}$ power defined in Table 7.7.1-2 is increased by the amount given by $\Delta R_{\text{IB,c}}$ in Table 7.3.1-1A.

7.7.1A Minimum requirements for CA

For inter-band carrier aggregation with uplink assigned to one E-UTRA band the spurious response requirements are defined with the uplink active on the band other than the band whose downlink is being tested. The throughput measured in each downlink with $F_{\text{interferer}}$ in Table 7.6.2.1A-0 at spurious response frequencies shall be $\geq 95\%$ of the maximum throughput of the reference measurement channels as specified in Annexes A.2.2, A.2.3 and A.3.2 (with one sided dynamic OCNG Pattern OP.1 FDD/TDD for the DL-signal as described in Annex A.5.1.1/A.5.2.1) with parameters specified in Tables 7.7.1-1 and 7.7.1-2. The UE shall meet these requirements for each component carrier while both downlink carriers are active.

For intra-band contiguous carrier aggregation the downlink SCC shall be configured at nominal channel spacing to the PCC with the PCC configured closest to the uplink band. Downlink PCC and SCC are both activated. The uplink output power shall be set as specified in Table 7.7.1A-1 with the uplink configuration set according to Table 7.3.1A-1 for the applicable carrier aggregation configuration. For UE(s) supporting one uplink carrier, the uplink configuration of the PCC shall be in accordance with Table 7.3.1-2. The throughput of each carrier shall be $\geq 95\%$ of the maximum throughput of the reference measurement channels as specified in Annexes A.2.2, A.2.3 and A.3.2 (with one sided dynamic OCNG Pattern OP.1 FDD/TDD for the DL-signal as described in Annex A.5.1.1/A.5.2.1) with parameters specified in Tables 7.7.1A-1 and 7.7.1A-2.

Table 7.7.1A-1: Spurious response parameters

Rx Parameter	Units	CA Bandwidth Class				
		B	C	D	E	F
Pw in Transmission Bandwidth Configuration, per CC	dBm	REFSENS + CA Bandwidth Class specific value below				
			9			
NOTE 1: The transmitter shall be set to 4dB below $P_{\text{CMAX_L,c}}$ or $P_{\text{CMAX_L}}$ as defined in subclause 6.2.5A.						
NOTE 2: Reference measurement channel is specified in Annex A.3.2 with one sided dynamic OCNG Pattern OP.1 FDD/TDD as described in Annex A.5.1.1/A.5.2.1.						

Table 7.7.1A-2: Spurious response

Parameter	Unit	Level
$P_{\text{Interferer}}$ (CW)	dBm	-44
$F_{\text{Interferer}}$	MHz	Spurious response frequencies

7.7.1B Minimum requirements for UL-MIMO

For UE with two transmitter antenna connectors in closed-loop spatial multiplexing scheme, the minimum requirements in Clause 7.7.1 shall be met with the UL-MIMO configurations specified in Table 6.2.2B-2. For UL-MIMO, the parameter $P_{\text{CMAX_L}}$ is defined as the total transmitter power over the two transmit antenna connectors.

7.8 Intermodulation characteristics

Intermodulation response rejection is a measure of the capability of the receiver to receive a wanted signal on its assigned channel frequency in the presence of two or more interfering signals which have a specific frequency relationship to the wanted signal.

7.8.1 Wide band intermodulation

The wide band intermodulation requirement is defined following the same principles using modulated E-UTRA carrier and CW signal as interferer.

7.8.1.1 Minimum requirements

The throughput shall be $\geq 95\%$ of the maximum throughput of the reference measurement channels as specified in Annexes A.2.2, A.2.3 and A.3.2 (with one sided dynamic OCNG Pattern OP.1 FDD/TDD for the DL-signal as described in Annex A.5.1.1/A.5.2.1) with parameters specified in Table 7.8.1.1 for the specified wanted signal mean power in the presence of two interfering signals

Table 7.8.1.1-1: Wide band intermodulation

Rx Parameter	Units	Channel bandwidth					
		1.4 MHz	3 MHz	5 MHz	10 MHz	15 MHz	20 MHz
Power in Transmission Bandwidth Configuration	dBm	REFSENS + channel bandwidth specific value below					
		12	8	6	6	7	9
$P_{\text{Interferer 1 (CW)}}$	dBm	-46					
$P_{\text{Interferer 2 (Modulated)}}$	dBm	-46					
$BW_{\text{Interferer 2}}$		1.4	3	5			
$F_{\text{Interferer 1 (Offset)}}$	MHz	-BW/2 -2.1 / +BW/2+ 2.1	-BW/2 -4.5 / +BW/2 + 4.5	-BW/2 - 7.5 / +BW/2 + 7.5			
$F_{\text{Interferer 2 (Offset)}}$	MHz	$2 \cdot F_{\text{Interferer 1}}$					
NOTE 1: The transmitter shall be set to 4dB below $P_{\text{CMAX_L}}$ at the minimum uplink configuration specified in Table 7.3.1-2 with $P_{\text{CMAX_L}}$ as defined in subclause 6.2.5.							
NOTE 2: Reference measurement channel is specified in Annex A.3.2 with one sided dynamic OCNG Pattern OP.1 FDD/TDD as described in Annex A.5.1.1/A.5.2.1.							
NOTE 3: The modulated interferer consists of the Reference measurement channel specified in Annex A.3.2 with one sided dynamic OCNG Pattern OP.1 FDD/TDD as described in Annex A.5.1.1/A.5.2.1 with set-up according to Annex C.3.1 The interfering modulated signal is 5MHz E-UTRA signal as described in Annex D for channel bandwidth $\geq 5\text{MHz}$							

For the UE which supports inter band CA configuration in Table 7.3.1-1A, $P_{\text{interferer1}}$ and $P_{\text{interferer2}}$ powers defined in Table 7.8.1.1-1 are increased by the amount given by $\Delta R_{\text{IB,c}}$ in Table 7.3.1-1A.

7.8.1A Minimum requirements for CA

For inter-band carrier aggregation with uplink assigned to one E-UTRA band the wide band intermodulation requirements are defined with the uplink active on the band other than the band whose downlink is being tested. The UE shall meet the requirements specified in subclause 7.8.1.1 for each component carrier while both downlink carriers are active.

For intra-band contiguous carrier aggregation the downlink SCC shall be configured at nominal channel spacing to the PCC with the PCC configured closest to the uplink band. Downlink PCC and SCC are both activated. The uplink output power shall be set as specified in Table 7.8.1A-1 with the uplink configuration set according to Table 7.3.1A-1 for the applicable carrier aggregation configuration. For UE(s) supporting one uplink carrier, the uplink configuration of the PCC shall be in accordance with Table 7.3.1-2. The UE shall fulfil the minimum requirement in presence of an interfering signal specified in Table 7.8.1A-1 being on either side of the aggregated signal. The throughput of each carrier shall be $\geq 95\%$ of the maximum throughput of the reference measurement channels as specified in Annexes A.2.2, A.2.3 and A.3.2 (with one sided dynamic OCNG Pattern OP.1 FDD/TDD for the DL-signal as described in Annex A.5.1.1/A.5.2.1) with parameters specified in Table 7.8.1A-1

Table 7.8.1A-1: Wide band intermodulation

Rx parameter	Units	CA Bandwidth Class				
		B	C	D	E	F
P _w in Transmission Bandwidth Configuration, per CC	dBm	REFSENS + CA Bandwidth Class specific value below				
			12			
P _{Interferer 1} (CW)	dBm	-46				
P _{Interferer 2} (Modulated)	dBm	-46				
BW _{Interferer 2}	MHz		5			
F _{Interferer 1} (Offset)	MHz		-F _{Offset} -7.5 / + F _{Offset} +7.5			
F _{Interferer 2} (Offset)	MHz	2*F _{Interferer 1}				
NOTE 1: The transmitter shall be set to 4dB below P _{C_{MAX}L,c} or P _{C_{MAX}L} as defined in subclause 6.2.5A.						
NOTE 2: Reference measurement channel is specified in Annex A.3.2 with one sided dynamic OCNG Pattern OP.1 FDD/TDD as described in Annex A.5.1.1/A.5.2.1.						
NOTE 3: The modulated interferer consists of the Reference measurement channel specified in Annex A.3.2 with one sided dynamic OCNG Pattern OP.1 FDD/TDD as described in Annex A.5.1.1/A.5.2.1 with set-up according to Annex C.3.1.						
NOTE 4: The interfering modulated signal is 5MHz E-UTRA signal as described in Annex D for channel bandwidth ≥5MHz.						
NOTE 5: The F _{Interferer 1} (offset) is the frequency separation of the center frequency of the carrier closest to the interferer and the center frequency of the CW interferer and F _{Interferer 2} (offset) is the frequency separation of the center frequency of the carrier closest to the interferer and the center frequency of the modulated interferer.						

7.8.1B Minimum requirements for UL-MIMO

For UE(s) with two transmitter antenna connectors in closed-loop spatial multiplexing scheme, the minimum requirements in subclause 7.8.1 shall be met with the UL-MIMO configurations specified in Table 6.2.2B-2. For UL-MIMO, the parameter P_{C_{MAX}L} is defined as the total transmitter power over the two transmit antenna connectors.

7.8.2 Void

7.9 Spurious emissions

The spurious emissions power is the power of emissions generated or amplified in a receiver that appear at the UE antenna connector.

7.9.1 Minimum requirements

The power of any narrow band CW spurious emission shall not exceed the maximum level specified in Table 7.9.1-1

Table 7.9.1-1: General receiver spurious emission requirements

Frequency band	Measurement bandwidth	Maximum level	Note
$30\text{MHz} \leq f < 1\text{GHz}$	100 kHz	-57 dBm	
$1\text{GHz} \leq f \leq 12.75\text{GHz}$	1 MHz	-47 dBm	
$12.75\text{GHz} \leq f \leq 5^{\text{th}}$ harmonic of the upper frequency edge of the DL operating band in GHz	1 MHz	-47 dBm	1
NOTE 1: Applies only for Band 22, Band 42 and Band 43			
NOTE 2: Unused PDCCH resources are padded with resource element groups with power level given by PDCCH_RA/RB as defined in Annex C.3.1.			

7.10 Receiver image

7.10.1 Void

7.10.1A Minimum requirements for CA

Receiver image rejection is a measure of a receiver's ability to receive the E-UTRA signal on one component carrier while it is also configured to receive an adjacent aggregated carrier. Receiver image rejection ratio is the ratio of the wanted received power on a sub-carrier being measured to the unwanted image power received on the same sub-carrier when both sub-carriers are received with equal power at the UE antenna connector.

For intra-band contiguous carrier aggregation the UE shall fulfil the minimum requirement specified in Table 7.10.1A-1 for all values of aggregated input signal up to -22 dBm.

Table 7.10.1A-1: Receiver image rejection

Rx parameter	CA bandwidth class						
	Units	A	B	C	D	E	F
Receiver image rejection	dB			25			

8 Performance requirement

This clause contains performance requirements for the physical channels specified in TS 36.211 [4]. The performance requirements for the UE in this clause are specified for the measurement channels specified in Annex A.3, the propagation conditions in Annex B and the downlink channels in Annex C.3.2.

Note: For the requirements in the following sections, similar Release 8 and 9 requirements apply for time domain measurements restriction under colliding CRS.

8.1 General

8.1.1 Dual-antenna receiver capability

The performance requirements are based on UE(s) that utilize a dual-antenna receiver.

For all test cases, the SNR is defined as

$$SNR = \frac{\hat{E}_s^{(1)} + \hat{E}_s^{(2)}}{N_{oc}^{(1)} + N_{oc}^{(2)}}$$

where the superscript indicates the receiver antenna connector. The above SNR definition assumes that the REs are not precoded. The SNR definition does not account for any gain which can be associated to the precoding operation. The relative power of physical channels transmitted is defined in Table C.3.2-1. The SNR requirement applies for the UE categories and CA capabilities given for each test.

Table 8.1.1-1: Void

8.1.1.1 Simultaneous unicast and MBMS operations

8.1.1.2 Dual-antenna receiver capability in idle mode

8.1.2 Applicability of requirements

8.1.2.1 Applicability of requirements for different channel bandwidths

In Clause 8 the test cases may be defined with different channel bandwidth to verify the same target FRC conditions with the same propagation conditions, correlation matrix and antenna configuration.

8.1.2.2 Definition of CA capability

The definition with respect to CA capabilities for 2CCs is given as in Table 8.1.2.2-1.

Table 8.1.2.2-1: Definition of CA capability with 2DL CCs

CA Capability	CA Capability Description
CA2_C	Intra-band contiguous CA
CA2_A2	Inter-band CA
Note 1: CA2_C corresponds to E-UTRA CA configurations and bandwidth combination sets defined in Table 5.6A.1-1 for 2 DL CCs. CA2_A2 corresponds to E-UTRA CA configurations and bandwidth combination sets defined in Table 5.6A.1-2 for 2 DL CCs.	

The supported testable aggregated CA bandwidth combinations for 2CCs for each CA capability are listed in Table 8.1.2.2-2.

Table 8.1.2.2-2: Supported testable aggregated CA bandwidth combinations for different CA capability with 2DL CCs

CA Capability	Bandwidth combination for FDD CA	Bandwidth combination for TDD CA
CA2_C	20+20MHz	20+20MHz
CA2_A2	10+10MHz	NA
Note 1: This table is only for information and applicability and test rules of CA performance requirements are specified in 8.1.2.3 and 9.1.1.2.		

For test cases with more than one component carrier, "Fraction of Maximum Throughput" in the performance requirement refers to the ratio of the sum of throughput values of all component carriers to the sum of the nominal maximum throughput values of all component carriers.

8.1.2.3 Applicability and test rules for different CA configurations and bandwidth combination sets

The performance requirement for CA UE demodulation tests in Clause 8 are defined independent of CA configurations and bandwidth combination sets specified in Clause 5.6A.1. For UEs supporting different CA configurations and bandwidth combination sets, the applicability and test rules are defined for the tests for 2 DL CCs in Table 8.1.2.3-1. For simplicity, CA configuration below refers to combination of CA configuration and bandwidth combination set.

Table 8.1.2.3-1: Applicability and test rules for CA UE demodulation tests with 2 DL CCs

Tests	CA capability where the tests apply	CA configuration from the selected CA capability where the tests apply	CA Bandwidth combination to be tested in priority order
CA tests with 2CCs in Clause 8.2.1.1.1, 8.2.1.4.3	Any one of the supported CA capabilities	Any one of the supported FDD CA configurations	10+10 MHz, 20+20MHz
CA tests with 2CCs in Clause 8.2.1.3.1	Each supported CA capability	Any one of the supported FDD CA configurations in each CA capability	10+10 MHz, 20+20 MHz
CA tests with 2CCs in Clause 8.2.1.3.1A, 8.7.1	Any one of the supported CA capabilities with largest aggregated CA bandwidth combination	Any one of the supported FDD CA configurations with largest aggregated CA bandwidth combination	Largest aggregated CA bandwidth combination
CA tests with 2CCs in Clause 8.2.1.7.1	CA_C	Supported FDD intra-band contiguous CA configurations covering the lowest and highest operating bands	Largest aggregated CA bandwidth combinations
CA tests with 2CCs in Clause 8.2.2.1.1, 8.2.2.4.3	Any one of the supported CA capabilities with largest aggregated CA bandwidth combination	Any one of the supported TDD CA configurations with largest aggregated CA bandwidth combination	Largest aggregated CA bandwidth combination
CA tests with 2CCs in Clause 8.2.2.3.1	Each supported CA capability	Any one of the supported TDD CA configurations in each CA capability with largest aggregated CA bandwidth combination	Largest aggregated CA bandwidth combination
CA tests with 2CCs in Clause 8.2.2.3.1A, 8.7.2	Any one of the supported CA capabilities with largest aggregated CA bandwidth	Any one of the supported TDD CA configurations with largest aggregated CA bandwidth combination	Largest aggregated CA bandwidth combination
CA tests with 2CCs in 8.2.2.7.1	CA_C	Supported TDD intra-band contiguous CA configurations covering the lowest and highest operating bands	Largest aggregated CA bandwidth combinations
Note 1: The applicability and test rules are specified in this table, unless otherwise stated.			
Note 2: Number of the supported bandwidth combinations to be tested from each selected CA configuration is one.			

8.1.2.4 Test coverage for different number of component carriers

For FDD tests specified in 8.2.1.1.1, 8.2.1.3.1, 8.2.1.4.3, and 8.7.1, if corresponding CA tests are tested, the test coverage can be considered fulfilled without executing single carrier tests.

For TDD tests specified in 8.2.2.1.1, 8.2.2.3.1, 8.2.2.4.3, and 8.7.2, if corresponding CA tests are tested, the test coverage can be considered fulfilled without executing single carrier tests.

8.2 Demodulation of PDSCH (Cell-Specific Reference Symbols)

8.2.1 FDD (Fixed Reference Channel)

The parameters specified in Table 8.2.1-1 are valid for all FDD tests unless otherwise stated.

Table 8.2.1-1: Common Test Parameters (FDD)

Parameter	Unit	Value
Inter-TTI Distance		1
Number of HARQ processes per component carrier	Processes	8
Maximum number of HARQ transmission		4
Redundancy version coding sequence		{0,1,2,3} for QPSK and 16QAM {0,0,1,2} for 64QAM
Number of OFDM symbols for PDCCH per component carrier	OFDM symbols	4 for 1.4 MHz bandwidth, 3 for 3 MHz and 5 MHz bandwidths, 2 for 10 MHz, 15 MHz and 20 MHz bandwidths
Cyclic Prefix		Normal
Cell_ID		0
Cross carrier scheduling		Not configured

8.2.1.1 Single-antenna port performance

The single-antenna performance in a given multi-path fading environments is determined by the SNR for which a certain relative information bit throughput of the reference measurement channels in Annex A.3.3 is achieved. The purpose of these tests is to verify the single-antenna performance with different channel models and MCS. The QPSK and 64QAM cases are also used to verify the performance for all bandwidths specified in Table 5.6.1-1.

8.2.1.1.1 Minimum Requirement

For single carrier the requirements are specified in Table 8.2.1.1.1-2, with the addition of the parameters in Table 8.2.1.1.1-1 and the downlink physical channel setup according to Annex C.3.2. For CA the requirements are specified in Table 8.2.1.1.1-4, with the addition of the parameters in Table 8.2.1.1.1-3 and the downlink physical channel setup according to Annex C.3.2.

The test coverage for different number of component carriers is defined in 8.1.2.4.

Table 8.2.1.1.1-1: Test Parameters

Test num.	Band-width	Reference channel	OCNG pattern	Propa-gation condition	Correlation matrix and antenna config.	Reference value		UE category
						Fraction of maximum throughput (%)	SNR (dB)	
1	2x10 MHz	R.2 FDD	OP.1 FDD (Note 1)	EVA5	1x2 Low	70	-1.1	3-8 (Note 2)
2	2x20 MHz	R.42 FDD	OP.1 FDD (Note 1)	EVA5	1x2 Low	70	-1.3	5-8
Note 1: The OCNG pattern applies for each CC. Note 2: 30usec timing difference between two CCs is applied in inter-band CA case. Note 3: The applicability of requirements for different CA configurations and bandwidth combination sets is defined in 8.1.2.3.								

Parameter	Unit	Test 1- 5	Test 6- 8	Test 9- 15	Test 16- 18	Test 19
Downlink power allocation	ρ_A	dB	0	0	0	0
	ρ_B	dB	0 (Note 1)	0 (Note 1)	0 (Note 1)	0 (Note 1)
	σ	dB	0	0	0	0
N_{oc} at antenna port	dBm/15kHz	-98	-98	-98	-98	-98
Symbols for unused PRBs		OCNG (Note 2)	OCNG (Note 2)	OCNG (Note 2)	OCNG (Note 2)	OCNG (Note 2)
Modulation		QPSK	16QAM	64QAM	16QAM	QPSK
PDSCH transmission mode		1	1	1	1	1
Note 1: $P_B = 0$						
Note 2: These physical resource blocks are assigned to an arbitrary number of virtual UEs with one PDSCH per virtual UE; the data transmitted over the OCNG PDSCHs shall be uncorrelated pseudo random data, which is QPSK modulated.						
Note 3: Void.						
Note 4: Void.						

Table 8.2.1.1.1-2: Minimum performance (FRC)

Test num.	Bandwidth	Reference channel	OCNG pattern	Propagation condition	Correlation matrix and antenna config.	Reference value		UE category
						Fraction of maximum throughput (%)	SNR (dB)	
1	10 MHz	R.2 FDD	OP.1 FDD	EVA5	1x2 Low	70	-1.0	1-8
2	10 MHz	R.2 FDD	OP.1 FDD	ETU70	1x2 Low	70	-0.4	1-8
3	10 MHz	R.2 FDD	OP.1 FDD	ETU300	1x2 Low	70	0.0	1-8
4	10 MHz	R.2 FDD	OP.1 FDD	HST	1x2	70	-2.4	1-8
5	1.4 MHz	R.4 FDD	OP.1 FDD	EVA5	1x2 Low	70	0.0	1-8
6	10 MHz	R.3 FDD	OP.1 FDD	EVA5	1x2 Low	70	6.7	2-8
	5 MHz	R.3-1 FDD	OP.1 FDD	EVA5	1x2 Low	70	6.7	1
7	10 MHz	R.3 FDD	OP.1 FDD	ETU70	1x2 Low	30	1.4	2-8
	5 MHz	R.3-1 FDD	OP.1 FDD	ETU70	1x2 Low	30	1.4	1
8	10 MHz	R.3 FDD	OP.1 FDD	ETU300	1x2 High	70	9.4	2-8
	5 MHz	R.3-1 FDD	OP.1 FDD	ETU300	1x2 High	70	9.4	1
9	3 MHz	R.5 FDD	OP.1 FDD	EVA5	1x2 Low	70	17.6	1-8
10	5 MHz	R.6 FDD	OP.1 FDD	EVA5	1x2 Low	70	17.4	2-8
	5 MHz	R.6-1 FDD	OP.1 FDD	EVA5	1x2 Low	70	17.5	1
11	10 MHz	R.7 FDD	OP.1 FDD	EVA5	1x2 Low	70	17.7	2-8
	10 MHz	R.7-1 FDD	OP.1 FDD	EVA5	1x2 Low	70	16.7	1

12	10 MHz	R.7 FDD	OP.1 FDD	ETU70	1x2 Low	70	19.0	2-8
	10 MHz	R.7-1 FDD	OP.1 FDD	ETU70	1x2 Low	70	18.1	1
13	10 MHz	R.7 FDD	OP.1 FDD	EVA5	1x2 High	70	19.1	2-8
	10 MHz	R.7-1 FDD	OP.1 FDD	EVA5	1x2 High	70	17.8	1
14	15 MHz	R.8 FDD	OP.1 FDD	EVA5	1x2 Low	70	17.7	2-8
	15 MHz	R.8-1 FDD	OP.1 FDD	EVA5	1x2 Low	70	16.8	1
15	20 MHz	R.9 FDD	OP.1 FDD	EVA5	1x2 Low	70	17.6	3-8
	20 MHz	R.9-2 FDD	OP.1 FDD	EVA5	1x2 Low	70	17.3	2
	20 MHz	R.9-1 FDD	OP.1 FDD	EVA5	1x2 Low	70	16.7	1
16	3 MHz	R.0 FDD	OP.1 FDD	ETU70	1x2 Low	30	1.9	1-8
17	10 MHz	R.1 FDD	OP.1 FDD	ETU70	1x2 Low	30	1.9	1-8
18	20 MHz	R.1 FDD	OP.1 FDD	ETU70	1x2 Low	30	1.9	1-8
19	10 MHz	R.41 FDD	OP.1 FDD	EVA5	1x2 Low	70	-5.4	1-8
Note 1: Void. Note 2: Void. Note 3: Void.								

Table 8.2.1.1.1-3: Test Parameters for CA

Parameter		Unit	Test 1-2
Downlink power allocation	ρ_A	dB	0
	ρ_B	dB	0 (Note 1)
	σ	dB	0
N_{oc} at antenna port		dBm/15kHz	-98
Symbols for unused PRBs			OCNG (Note 2)
Modulation			QPSK
PDSCH transmission mode			1
Note 1: $P_B = 0$ Note 2: These physical resource blocks are assigned to an arbitrary number of virtual UEs with one PDSCH per virtual UE; the data transmitted over the OCNG PDSCHs shall be uncorrelated pseudo random data, which is QPSK modulated. Note 3: PUCCH format 1b with channel selection is used to feedback ACK/NACK. Note 4: The same PDSCH transmission mode is applied to each component carrier.			

Table 8.2.1.1.1-4: Minimum performance (FRC) for CA

Test num.	Bandwidth	Reference channel	OCNG pattern	Propagation condition	Correlation matrix and antenna config.	Reference value		UE category
						Fraction of maximum throughput (%)	SNR (dB)	

1	2x10 MHz	R.2 FDD	OP.1 FDD (Note 1)	EVA5	1x2 Low	70	-1.1	3-8 (Note 2)
2	2x20 MHz	R.42 FDD	OP.1 FDD (Note 1)	EVA5	1x2 Low	70	-1.3	5-8
Note 1: The OCNG pattern applies for each CC. Note 2: 30usec timing difference between two CCs is applied in inter-band CA case. Note 3: The applicability of requirements for different CA configurations and bandwidth combination sets is defined in 8.1.2.3.								

8.2.1.1.2 Void

8.2.1.1.3 Void

8.2.1.1.4 Minimum Requirement 1 PRB allocation in presence of MBSFN

The requirements are specified in Table 8.2.1.1.4-2, with the addition of the parameters in Table 8.2.1.1.4-1 and the downlink physical channel setup according to Annex C.3.2. The purpose of these tests is to verify the single-antenna performance with a single PRB allocated at the lower band edge in presence of MBSFN.

Table 8.2.1.1.4-1: Test Parameters for Testing 1 PRB allocation

Parameter	Unit	Test 1	
Downlink power allocation	ρ_A	dB	0
	ρ_B	dB	0 (Note 1)
	σ	dB	0
N_{oc} at antenna port	dBm/15kHz	-98	
Symbols for MBSFN portion of MBSFN subframes (Note 2)		OCNG (Note 3)	
PDSCH transmission mode		1	
Note 1: $P_B = 0$ Note 2: The MBSFN portion of an MBSFN subframe comprises the whole MBSFN subframe except the first two symbols in the first slot. Note 3: The MBSFN portion of the MBSFN subframes shall contain QPSK modulated data. Cell-specific reference signals are not inserted in the MBSFN portion of the MBSFN subframes, QPSK modulated MBSFN data is used instead.			

Table 8.2.1.1.4-2: Minimum performance 1PRB (FRC)

Test number	Bandwidth	Reference Channel	OCNG Pattern	Propagation Condition	Correlation Matrix and Antenna Configuration	Reference value		UE Category
						Fraction of Maximum Throughput (%)	SNR (dB)	
1	10 MHz	R.29 FDD	OP.3 FDD	ETU70	1x2 Low	30	2.0	1-8

8.2.1.2 Transmit diversity performance

8.2.1.2.1 Minimum Requirement 2 Tx Antenna Port

The requirements are specified in Table 8.2.1.2.1-2, with the addition of the parameters in Table 8.2.1.2.1-1 and the downlink physical channel setup according to Annex C.3.2. The purpose is to verify the performance of transmit diversity (SFBC) with 2 transmitter antennas.

Table 8.2.1.2.1-1: Test Parameters for Transmit diversity Performance (FRC)

Parameter		Unit	Test 1-2
Downlink power allocation	ρ_A	dB	-3
	ρ_B	dB	-3 (Note 1)
	σ	dB	0
N_{oc} at antenna port		dBm/15kHz	-98
PDSCH transmission mode			2
Note 1: $P_B = 1$.			

Table 8.2.1.2.1-2: Minimum performance Transmit Diversity (FRC)

Test number	Bandwidth	Reference Channel	OCNG Pattern	Propagation Condition	Correlation Matrix and Antenna Configuration	Reference value		UE Category
						Fraction of Maximum Throughput (%)	SNR (dB)	
1	10 MHz	R.11 FDD	OP.1 FDD	EVA5	2x2 Medium	70	6.8	2-8
	5 MHz	R.11-2 FDD	OP.1 FDD	EVA5	2x2 Medium	70	5.9	1
2	10 MHz	R.10 FDD	OP.1 FDD	HST	2x2	70	-2.3	1-8

8.2.1.2.2 Minimum Requirement 4 Tx Antenna Port

The requirements are specified in Table 8.2.1.2.2-2, with the addition of the parameters in Table 8.2.1.2.2-1 and the downlink physical channel setup according Annex C.3.2. The purpose is to verify the performance of transmit diversity (SFBC-FSTD) with 4 transmitter antennas.

Table 8.2.1.2.2-1: Test Parameters for Transmit diversity Performance (FRC)

Parameter		Unit	Test 1-2
Downlink power allocation	ρ_A	dB	-3
	ρ_B	dB	-3 (Note 1)
	σ	dB	0
N_{oc} at antenna port		dBm/15kHz	-98
PDSCH transmission mode			2
Note 1: $P_B = 1$.			

Table 8.2.1.2.2-2: Minimum performance Transmit Diversity (FRC)

Test number	Band-width	Reference Channel	OCNG Pattern	Propagation Condition	Correlation Matrix and Antenna Configuration	Reference value		UE Category
						Fraction of Maximum Throughput (%)	SNR (dB)	
1	1.4 MHz	R.12 FDD	OP.1 FDD	EPA5	4x2 Medium	70	0.6	1-8
2	10 MHz	R.13 FDD	OP.1 FDD	ETU70	4x2 Low	70	-0.9	1-8

8.2.1.2.3 Minimum Requirement 2 Tx Antenna Ports (demodulation subframe overlaps with aggressor cell ABS)

The requirements are specified in Table 8.2.1.2.3-2, with the addition of parameters in Table 8.2.1.2.3-1 and the downlink physical channel setup according to Annex C.3.2 and Annex C.3.3. The purpose is to verify the performance of transmit diversity (SFBC) with 2 transmit antennas if the PDSCH transmission in the serving cell takes place in subframes that overlap with ABS [9] of the aggressor cell. In Table 8.2.1.2.3-1, Cell 1 is the serving cell, and Cell 2 is the aggressor cell. The downlink physical channel setup for Cell 1 is according to Annex C.3.2 and for Cell 2 is according to Annex C.3.3, respectively.

Table 8.2.1.2.3-1: Test Parameters for Transmit diversity Performance (FRC)

Parameter		Unit	Cell 1	Cell 2
Downlink power allocation	ρ_A	dB	-3	-3
	ρ_B	dB	-3 (Note 1)	-3
	σ	dB	0	N/A
N_{oc} at antenna port	N_{oc1}	dBm/15kHz	-102 (Note 2)	N/A
	N_{oc2}	dBm/15kHz	-98 (Note 3)	N/A
	N_{oc3}	dBm/15kHz	-94.8 (Note 4)	N/A
\widehat{E}_s / N_{oc2}		dB	Reference Value in Table 8.2.1.2.3-2	6
BW _{Channel}		MHz	10	10
Subframe Configuration			Non-MBSFN	Non-MBSFN
Time Offset between Cells		μs	2.5 (synchronous cells)	
Cell Id			0	1
ABS pattern (Note 5)			N/A	11000100 11000000 11000000 11000000 11000000
RLM/RRM Measurement Subframe Pattern (Note 6)			10000000 10000000 10000000 10000000 10000000	N/A
CSI Subframe Sets (Note7)	C _{CSI,0}		11000100 11000000 11000000 11000000 11000000	N/A
	C _{CSI,1}		00111011 00111111 00111111 00111111 00111111	N/A
Number of control OFDM symbols			2	2
PDSCH transmission mode			2	N/A
Cyclic prefix			Normal	Normal
<p>Note 1: $P_B = 1$.</p> <p>Note 2: This noise is applied in OFDM symbols #1, #2, #3, #5, #6, #8, #9, #10, #12, #13 of a subframe overlapping with the aggressor ABS.</p> <p>Note 3: This noise is applied in OFDM symbols #0, #4, #7, #11 of a subframe overlapping with the aggressor ABS.</p> <p>Note 4: This noise is applied in all OFDM symbols of a subframe overlapping with aggressor non-ABS</p> <p>Note 5: ABS pattern as defined in [9].</p> <p>Note 6: Time-domain measurement resource restriction pattern for PCell measurements as defined in [7]</p> <p>Note 7: As configured according to the time-domain measurement resource restriction pattern for CSI measurements defined in [7].</p> <p>Note 8: Cell 1 is the serving cell. Cell 2 is the aggressor cell. The number of the CRS ports in Cell1 and Cell2 is the same.</p> <p>Note 9: SIB-1 will not be transmitted in Cell2 in this test.</p>				

Table 8.2.1.2.3-2: Minimum Performance Transmit Diversity (FRC)

Test Number	Reference Channel	OCNG Pattern		Propagation Conditions (Note 1)		Correlation Matrix and Antenna Configuration	Reference Value		UE Category
		Cell 1	Cell 2	Cell 1	Cell 2		Fraction of Maximum Throughput (%) (Note 5)	SNR (dB) (Note 2)	
1	R.11-4 FDD (Note 4)	OP.1 FDD	OP.1 FDD	EVA5	EVA 5	2x2 Medium	70	3.4	2-8
Note 1: The propagation conditions for Cell 1 and Cell2 are statistically independent. Note 2: SNR corresponds to \widehat{E}_s / N_{oc2} of cell 1. Note 3: The correlation matrix and antenna configuration apply for Cell 1 and Cell 2. Note 4: Cell 1 Reference channel is modified: PDSCH other than SIB1/paging and its associated PDCCH/PCFICH are transmitted in the serving cell subframe when the subframe is overlapped with the ABS subframe of aggressor cell and the subframe is available in the definition of the reference channel. Note 5: The maximum Throughput is calculated from the total Payload in 9 subframes, averaged over 40ms.									

8.2.1.3 Open-loop spatial multiplexing performance

8.2.1.3.1 Minimum Requirement 2 Tx Antenna Port

For single carrier the requirements are specified in Table 8.2.1.3.1-2, with the addition of the parameters in Table 8.2.1.3.1-1 and the downlink physical channel setup according to Annex C.3.2. The purpose is to verify the performance of large delay CDD with 2 transmitter antennas. For CA the requirements are specified in Table 8.2.1.3.1-4, with the addition of the parameters in Table 8.2.1.3.1-3 and the downlink physical channel setup according to Annex C.3.2. The purpose is to verify the performance of large delay CDD with 2 transmitter antennas.

The test coverage for different number of component carriers is defined in 8.1.2.4.

Table 8.2.1.3.1-1: Test Parameters for Large Delay CDD (FRC)

Parameter	Unit	Test 1
Downlink power allocation	ρ_A	dB
	ρ_B	dB
	σ	dB
N_{oc} at antenna port	dBm/15kHz	-98
PDSCH transmission mode		3
Note 1: $P_B = 1$. Note 2: Void. Note 3: Void.		

Table 8.2.1.3.1-2: Minimum performance Large Delay CDD (FRC)

Test num.	Band-width	Referencechannel	OCNG pattern	Propa-gation condi-tion	Correlation matrix and antenna config.	Reference value		UE category
						Fraction of maximum Throughput (%)	SNR (dB)	
1	10 MHz	R.11 FDD	OP.1 FDD	EVA70	2x2 Low	70	13.0	2-8
Note 1: Void. Note 2: Test 1 may not be executed for UE-s for which Test 1 or 2 in Table 8.2.1.3.1-4 is applicable.								

Table 8.2.1.3.1-3: Test Parameters for Large Delay CDD (FRC) for CA

Parameter		Unit	Test 1-2
Downlink power allocation	ρ_A	dB	-3
	ρ_B	dB	-3 (Note 1)
	σ	dB	0
N_{oc} at antenna port		dBm/15kHz	-98
PDSCH transmission mode			3
Note 1: $P_B = 1$.			
Note 2: PUCCH format 1b with channel selection is used to feedback ACK/NACK.			
Note 3: The same PDSCH transmission mode is applied to each component carrier.			

Table 8.2.1.3.1-4: Minimum performance Large Delay CDD (FRC) for CA

Test num.	Bandwidth	Reference channel	OCNG pattern	Propagation condition	Correlation matrix and antenna config.	Reference value		UE category
						Fraction of maximum Throughput (%)	SNR (dB)	
1	2x10 MHz	R.11 FDD	OP.1 FDD (Note 1)	EVA70	2x2 Low	70	13.7	3-8
2	2x20 MHz	R.30 FDD	OP.1 FDD (Note 1)	EVA70	2x2 Low	70	13.2	5-8
Note 1: The OCNG pattern applies for each CC.								
Note 2: Void.								
Note 3: The applicability of requirements for different CA configurations and bandwidth combination sets is defined in 8.1.2.3.								

8.2.1.3.1A Soft buffer management test

For CA the requirements are specified in Table 8.2.1.3.1A-2, with the addition of the parameters in Table 8.2.1.3.1A-1 and the downlink physical channel setup according to Annex C.3.2. The purpose is to verify the UE performance with proper instantaneous buffer implementation.

Table 8.2.1.3.1A-1: Test Parameters for soft buffer management test (FRC) for CA

Parameter		Unit	Test 1-2
Downlink power allocation	ρ_A	dB	-3
	ρ_B	dB	-3 (Note 1)
	σ	dB	0
N_{oc} at antenna port		dBm/15kHz	-98
PDSCH transmission mode			3
Note 1: $P_B = 1$			
Note 2: For CA test cases, PUCCH format 1b with channel selection is used to feedback ACK/NACK.			
Note 3: For CA test cases, the same PDSCH transmission mode is applied to each component carrier.			

Table 8.2.1.3.1A-2: Minimum performance for soft buffer management test (FRC) for CA

Test num.	Band-width	Reference channel	OCNG pattern	Propagation condition	Correlation matrix and antenna config.	Reference value		UE category
						Fraction of maximum Throughput (%)	SNR (dB)	
1	2x20 MHz	R.30 FDD	OP.1 FDD (Note 1)	EVA70	2x2 Low	70	13.2	3
2	2x20 MHz	R.35-1 FDD	OP.1 FDD (Note 1)	EVA5	2x2 Low	70	15.8	4

Note 1: For CA test cases, the OCNG pattern applies for each CC.
Note 2: The applicability of requirements for different CA configurations and bandwidth combination sets is defined in 8.1.2.3.

8.2.1.3.2 Minimum Requirement 4 Tx Antenna Port

The requirements are specified in Table 8.2.1.3.2-2, with the addition of the parameters in Table 8.2.1.3.2-1 and the downlink physical channel setup according to Annex C.3.2. The purpose is to verify the performance of large delay CDD with 4 transmitter antennas.

Table 8.2.1.3.2-1: Test Parameters for Large Delay CDD (FRC)

Parameter	Unit	Test 1
Downlink power allocation	ρ_A	dB
	ρ_B	dB
	σ	dB
N_{oc} at antenna port	dBm/15kHz	-98
PDSCH transmission mode		3
Note 1: $P_B = 1$		

Table 8.2.1.3.2-2: Minimum performance Large Delay CDD (FRC)

Test number	Band-width	Reference Channel	OCNG Pattern	Propagation Condition	Correlation Matrix and Antenna Configuration	Reference value		UE Category
						Fraction of Maximum Throughput (%)	SNR (dB)	
1	10 MHz	R.14 FDD	OP.1 FDD	EVA70	4x2 Low	70	14.3	2-8

8.2.1.3.3 Minimum Requirement 2 Tx Antenna Port (demodulation subframe overlaps with aggressor cell ABS)

The requirements for non-MBSFN ABS are specified in Table 8.2.1.3.3-2, with the addition of parameters in Table 8.2.1.3.3-1 and the downlink physical channel setup according to Annex C.3.2 and Annex C.3.3.

The requirements for MBSFN ABS are specified in Table 8.2.1.3.3-4, with the addition of parameters in Table 8.2.1.3.3-3 and the downlink physical channel setup according to Annex C.3.2 and Annex C.3.3.

The purpose is to verify the performance of large delay CDD with 2 transmitter antennas if the PDSCH transmission in the serving cell takes place in subframes that overlap with ABS [9] of the aggressor cell. In Tables 8.2.1.3.3-1 and 8.2.1.3.3-3, Cell 1 is the serving cell, and Cell 2 is the aggressor cell. The downlink physical channel setup for Cell 1 is according to Annex C.3.2 and for Cell 2 is according to Annex C.3.3, respectively.

Table 8.2.1.3.3-1: Test Parameters for Large Delay CDD (FRC) – Non-MBSFN ABS

Parameter		Unit	Cell 1	Cell 2
Downlink power allocation	ρ_A	dB	-3	-3
	ρ_B	dB	-3 (Note 1)	-3
	σ	dB	0	N/A
N_{oc} at antenna port	N_{oc1}	dBm/15kHz	-102 (Note 2)	N/A
	N_{oc2}	dBm/15kHz	-98 (Note 3)	N/A
	N_{oc3}	dBm/15kHz	-94.8 (Note 4)	N/A
\widehat{E}_s / N_{oc2}		dB	Reference Value in Table 8.2.1.3.3-2	6
BW _{Channel}		MHz	10	10
Subframe Configuration			Non-MBSFN	Non-MBSFN
Cell Id			0	1
Time Offset between Cells		μ s	2.5 (synchronous cells)	
ABS pattern (Note 5)			N/A	11000100, 11000000, 11000000, 11000000, 11000000
RLM/RRM Measurement Subframe Pattern(Note 6)			10000000 10000000 10000000 10000000 10000000	N/A
CSI Subframe Sets (Note 7)	$C_{CSI,0}$		11000100 11000000 11000000 11000000 11000000	N/A
	$C_{CSI,1}$		00111011 00111111 00111111 00111111 00111111	N/A
Number of control OFDM symbols			2	2
PDSCH transmission mode			3	N/A
Cyclic prefix			Normal	Normal
<p>Note 1: $P_B = 1$.</p> <p>Note 2: This noise is applied in OFDM symbols #1, #2, #3, #5, #6, #8, #9, #10,#12, #13 of a subframe overlapping with the aggressor ABS.</p> <p>Note 3: This noise is applied in OFDM symbols #0, #4, #7, #11 of a subframe overlapping with the aggressor ABS.</p> <p>Note 4: This noise is applied in all OFDM symbols of a subframe overlapping with aggressor non-ABS</p> <p>Note 5: ABS pattern as defined in [9].</p> <p>Note 6: Time-domain measurement resource restriction pattern for PCell measurements as defined in [7].</p> <p>Note 7: As configured according to the time-domain measurement resource restriction pattern for CSI measurements defined in [7].</p> <p>Note 8: Cell 1 is the serving cell. Cell 2 is the aggressor cell. The number of the CRS ports in Cell1 and Cell2 is the same.</p> <p>Note 9: SIB-1 will not be transmitted in Cell2 in this test.</p>				

Table 8.2.1.3.3-2: Minimum Performance Large Delay CDD (FRC) – Non-MBSFN ABS

Test Number	Reference Channel	OCNG Pattern		Propagation Conditions (Note 1)		Correlation Matrix and Antenna Configuration	Reference Value		UE Category
		Cell 1	Cell 2	Cell 1	Cell 2		Fraction of Maximum Throughput (%) (Note 5)	SNR (dB) (Note 2)	
1	R.11 FDD (Note 4)	OP.1 FDD	OP.1 FDD	EVA 5	EVA 5	2x2 Low	70	13.3	2-8
<p>Note 1: The propagation conditions for Cell 1 and Cell2 are statistically independent.</p> <p>Note 2: SNR corresponds to \hat{E}_s / N_{oc2} of cell 1.</p> <p>Note 3: The correlation matrix and antenna configuration apply for Cell 1 and Cell 2.</p> <p>Note 4: Cell 1 Reference channel is modified: PDSCH other than SIB1/paging and its associated PDCCH/PCFICH are transmitted in the serving cell subframe when the subframe is overlapped with the ABS subframe of aggressor cell and the subframe is available in the definition of the reference channel.</p> <p>Note 5: The maximum Throughput is calculated from the total Payload in 9 subframes, averaged over 40ms.</p>									

Table 8.2.1.3.3-3: Test Parameters for Large Delay CDD (FRC) – MBSFN ABS

Parameter		Unit	Cell 1	Cell 2
Downlink power allocation	ρ_A	dB	-3	-3
	ρ_B	dB	-3 (Note 1)	-3
	σ	dB	0	N/A
N_{oc} at antenna port	N_{oc1}	dBm/15kHz	-102 (Note 2)	N/A
	N_{oc2}	dBm/15kHz	-98 (Note 3)	N/A
	N_{oc3}	dBm/15kHz	-94.8 (Note 4)	N/A
\widehat{E}_s / N_{oc2}		dB	Reference Value in Table 8.2.1.3.3-4	6
BW _{Channel}		MHz	10	10
Subframe Configuration			Non-MBSFN	MBSFN
Cell Id			0	126
Time Offset between Cells		μ s	2.5 (synchronous cells)	
ABS pattern (Note 5)			N/A	0001000000 0100000010 0000001000 0000000000
RLM/RRM Measurement Subframe Pattern (Note 6)			0001000000 0100000010 0000001000 0000000000	N/A
CSI Subframe Sets (Note 7)	C _{CSI,0}		0001000000 0100000010 0000001000 0000000000	N/A
	C _{CSI,1}		1110111111 1011111101 1111110111 1111111111	N/A
MBSFN Subframe Allocation (Note 10)			N/A	001000 100001 000100 000000
Number of control OFDM symbols			2	2
PDSCH transmission mode			3	N/A
Cyclic prefix			Normal	Normal
<p>Note 1: $P_B = 1$.</p> <p>Note 2: This noise is applied in OFDM symbols #1, #2, #3, #4, #5, #6, #7, #8, #9, #10, #11, #12, #13 of a subframe overlapping with the aggressor ABS.</p> <p>Note 3: This noise is applied in OFDM symbol #0 of a subframe overlapping with the aggressor ABS.</p> <p>Note 4: This noise is applied in all OFDM symbols of a subframe overlapping with aggressor non-ABS.</p> <p>Note 5: ABS pattern as defined in [9]. The 4th, 12th, 19th and 27th subframes indicated by ABS pattern are MBSFN ABS subframes.</p> <p>Note 6: Time-domain measurement resource restriction pattern for PCell measurements as defined in [7].</p> <p>Note 7: As configured according to the time-domain measurement resource restriction pattern for CSI measurements defined in [7].</p> <p>Note 8: Cell 1 is the serving cell. Cell 2 is the aggressor cell. The number of the CRS ports in Cell1 and Cell2 is the same.</p> <p>Note 9: SIB-1 will not be transmitted in Cell2 in this test.</p> <p>Note 10: MBSFN Subframe Allocation as defined in [7], four frames with 24 bits is chosen for MBSFN subframe allocation.</p> <p>Note 11: The maximum number of uplink HARQ transmission is ≤ 2 so that each PHICH channel transmission is in a subframe protected by MBSFN ABS in this test.</p>				

Table 8.2.1.3.3-4: Minimum Performance Large Delay CDD (FRC) – MBSFN ABS

Test Number	Reference Channel	OCNG Pattern		Propagation Conditions (Note 1)		Correlation Matrix and Antenna Configuration	Reference Value		UE Category
		Cell 1	Cell 2	Cell 1	Cell 2		Fraction of Maximum Throughput (%) (Note 5)	SNR (dB) (Note 2)	
1	R.11 FDD (Note 4)	OP.1 FDD	OP.1 FDD	EVA 5	EVA 5	2x2 Low	70	12.0	2-8
Note 1: The propagation conditions for Cell 1 and Cell2 are statistically independent. Note 2: SNR corresponds to \hat{E}_s / N_{oc2} of cell 1. Note 3: The correlation matrix and antenna configuration apply for Cell 1 and Cell 2. Note 4: Cell 1 Reference channel is modified: PDSCH other than SIB1/paging and its associated PDCCH/PCFICH are transmitted in the serving cell subframe when the subframe is overlapped with the ABS subframe of aggressor cell and the subframe is available in the definition of the reference channel. Note 5: The maximum Throughput is calculated from the total Payload in 4 subframes, averaged over 40ms.									

8.2.1.4 Closed-loop spatial multiplexing performance

8.2.1.4.1 Minimum Requirement Single-Layer Spatial Multiplexing 2 Tx Antenna Port

The requirements are specified in Table 8.2.1.4.1-2, with the addition of the parameters in Table 8.2.1.4.1-1 and the downlink physical channel setup according to Annex C.3.2. The purpose of these tests is to verify the closed loop rank-one performance with wideband and frequency selective precoding.

Table 8.2.1.4.1-1: Test Parameters for Single-Layer Spatial Multiplexing (FRC)

Parameter	Unit	Test 1	Test 2
Downlink power allocation	ρ_A	dB	-3
	ρ_B	dB	-3 (Note 1)
	σ	dB	0
N_{oc} at antenna port	dBm/15kHz	-98	-98
Precoding granularity	PRB	6	50
PMI delay (Note 2)	ms	8	8
Reporting interval	ms	1	1
Reporting mode		PUSCH 1-2	PUSCH 3-1
CodeBookSubsetRestrict on bitmap		001111	001111
PDSCH transmission mode		4	4
Note 1: $P_B = 1$. Note 2: If the UE reports in an available uplink reporting instance at subframe SF#n based on PMI estimation at a downlink SF not later than SF#(n-4), this reported PMI cannot be applied at the eNB downlink before SF#(n+4).			

Table 8.2.1.4.1-2: Minimum performance Single-Layer Spatial Multiplexing (FRC)

Test number	Band-width	Reference Channel	OCNG Pattern	Propagation Condition	Correlation Matrix and Antenna Configuration	Reference value		UE Category
						Fraction of Maximum Throughput (%)	SNR (dB)	
1	10 MHz	R.10 FDD	OP.1 FDD	EVA5	2x2 Low	70	-2.5	1-8
2	10 MHz	R.10 FDD	OP.1 FDD	EPA5	2x2 High	70	-2.3	1-8

8.2.1.4.1A Minimum Requirement Single-Layer Spatial Multiplexing 4 Tx Antenna Port

The requirements are specified in Table 8.2.1.4.1A-2, with the addition of the parameters in Table 8.2.1.4.1A-1 and the downlink physical channel setup according to Annex C.3.2. The purpose of these tests is to verify the closed loop rank-one performance with wideband and frequency selective precoding.

Table 8.2.1.4.1A-1: Test Parameters for Single-Layer Spatial Multiplexing (FRC)

Parameter		Unit	Test 1
Downlink power allocation	ρ_A	dB	-6
	ρ_B	dB	-6 (Note 1)
	σ	dB	3
N_{oc} at antenna port		dBm/15kHz	-98
Precoding granularity		PRB	6
PMI delay (Note 2)		ms	8
Reporting interval		ms	1
Reporting mode			PUSCH 1-2
CodeBookSubsetRestriction bitmap			0000000000000000 0000000000000000 0000000000000000 1111111111111111
PDSCH transmission mode			4
Note 1: $P_B = 1$.			
Note 2: If the UE reports in an available uplink reporting instance at subframe SF#n based on PMI estimation at a downlink SF not later than SF#(n-4), this reported PMI cannot be applied at the eNB downlink before SF#(n+4).			

Table 8.2.1.4.1A-2: Minimum performance Single-Layer Spatial Multiplexing (FRC)

Test number	Bandwidth	Reference Channel	OCNG Pattern	Propagation Condition	Correlation Matrix and Antenna Configuration	Reference value		UE Category
						Fraction of Maximum Throughput (%)	SNR (dB)	
1	10 MHz	R.13 FDD	OP.1 FDD	EVA5	4x2 Low	70	-3.2	1-8

8.2.1.4.2 Minimum Requirement Multi-Layer Spatial Multiplexing 2 Tx Antenna Port

The requirements are specified in Table 8.2.1.4.2-2, with the addition of the parameters in Table 8.2.1.4.2-1 and the downlink physical channel setup according to Annex C.3.2. The purpose of these tests is to verify the closed loop rank-two performance with wideband and frequency selective precoding.

Table 8.2.1.4.2-1: Test Parameters for Multi-Layer Spatial Multiplexing (FRC)

Parameter	Unit	Test 1-2	
Downlink power allocation	ρ_A	dB	-3
	ρ_B	dB	-3 (Note 1)
	σ	dB	0
N_{oc} at antenna port	dBm/15kHz	-98	
Precoding granularity	PRB	50	
PMI delay (Note 2)	ms	8	
Reporting interval	ms	1	
Reporting mode		PUSCH 3-1	
CodeBookSubsetRestriction bitmap		110000	
PDSCH transmission mode		4	
Note 1: $P_B = 1$.			
Note 2: If the UE reports in an available uplink reporting instance at subframe SF#n based on PMI estimation at a downlink SF not later than SF#(n-4), this reported PMI cannot be applied at the eNB downlink before SF#(n+4).			

Table 8.2.1.4.2-2: Minimum performance Multi-Layer Spatial Multiplexing (FRC)

Test number	Band-width	Reference Channel	OCNG Pattern	Propagation Condition	Correlation Matrix and Antenna Configuration	Reference value		UE Category
						Fraction of Maximum Throughput (%)	SNR (dB)	
1	10 MHz	R.35 FDD	OP.1 FDD	EPA5	2x2 Low	70	18.9	2-8
2	10 MHz	R.11 FDD	OP.1 FDD	ETU70	2x2 Low	70	14.3	2-8

8.2.1.4.3 Minimum Requirement Multi-Layer Spatial Multiplexing 4 Tx Antenna Port

For single carrier the requirements are specified in Table 8.2.1.4.3-2, with the addition of the parameters in Table 8.2.1.4.3-1 and the downlink physical channel setup according to Annex C.3.2. For CA the requirements are specified in Table 8.2.1.4.3-4, with the addition of the parameters in Table 8.2.1.4.3-2 and the downlink physical channel setup according to Annex C.3.2. The purpose of these tests is to verify the closed loop rank-two performance with wideband and frequency selective precoding.

The test coverage for different number of component carriers is defined in 8.1.2.4.

Table 8.2.1.4.3-1: Test Parameters for Multi-Layer Spatial Multiplexing (FRC)

Parameter	Unit	Test 1	
Downlink power allocation	ρ_A	dB	-6
	ρ_B	dB	-6 (Note 1)
	σ	dB	3

N_{oc} at antenna port	dBm/15kHz	-98
Precoding granularity	PRB	6
PMI delay (Note 2)	ms	8
Reporting interval	ms	1
Reporting mode		PUSCH 1-2
CodeBookSubsetRestriction bitmap		000000000000 000000000000 000000111111 111111110000 000000000000
PDSCH transmission mode		4
Note 1: $P_B = 1$. Note 2: If the UE reports in an available uplink reporting instance at subframe SF#n based on PMI estimation at a downlink SF not later than SF#(n-4), this reported PMI cannot be applied at the eNB downlink before SF#(n+4). Note 3: Void. Note 4: Void. Note 5: Void.		

Table 8.2.1.4.3-2: Minimum performance Multi-Layer Spatial Multiplexing (FRC)

Test num.	Bandwidth	Referencechannel	OCNG pattern	Propagation condition	Correlation matrix and antenna config.	Reference value		UE category
						Fraction of maximum throughput (%)	SNR (dB)	
1	10 MHz	R.36 FDD	OP.1 FDD	EPA5	4x2 Low	70	14.7	2-8
Note 1: Void.								

Table 8.2.1.4.3-3: Test Parameters for Multi-Layer Spatial Multiplexing (FRC) for CA

Parameter	Unit	Test 1	Test 2
Downlink power allocation	ρ_A	dB	-6
	ρ_B	dB	-6 (Note 1)
	σ	dB	3
N_{oc} at antenna port	dBm/15kHz	-98	-98
Precoding granularity	PRB	6	8
PMI delay (Note 2)	ms	8	8
Reporting interval	ms	1	1
Reporting mode		PUSCH 1-2	PUSCH 1-2
CodeBookSubsetRestriction bitmap		000000000000 000000000000 000000111111 111111110000 000000000000	000000000000 000000000000 000000111111 111111110000 000000000000
CSI request field (Note 3)		'10'	
PDSCH transmission mode		4	
Note 1: $P_B = 1$. Note 2: If the UE reports in an available uplink reporting instance at subframe SF#n based on PMI estimation at a downlink SF not later than SF#(n-4), this reported PMI cannot be applied at the eNB downlink before SF#(n+4). Note 3: Multiple CC-s under test are configured as the 1 st set of serving cells by higher layers. Note 4: ACK/NACK bits are transmitted using PUSCH with PUCCH format 1b with channel selection configured. Note 5: The same PDSCH transmission mode is applied to each component carrier.			

Table 8.2.1.4.3-4: Minimum performance Multi-Layer Spatial Multiplexing (FRC) for CA

Test num.	Bandwidth	Reference channel	OCNG pattern	Propagation condition	Correlation matrix and antenna config.	Reference value		UE category
						Fraction of maximum throughput (%)	SNR (dB)	
1	2x10 MHz	R.14 FDD	OP.1 FDD (Note 1)	EVA5	4x2 Low	70	10.8	3-8
2	2x20 MHz	R.14-3 FDD	OP.1 FDD (Note 1)	EVA5	4x2 Low	70	[10.9]	5-8
Note 1: The OCNG pattern applies for each CC.								
Note 2: The applicability of requirements for different CA configurations and bandwidth combination sets is defined in 8.1.2.3.								

8.2.1.5 MU-MIMO

8.2.1.6 [Control channel performance: D-BCH and PCH]

8.2.1.7 Carrier aggregation with power imbalance

The requirements in this section verify the ability of an intraband adjacent carrier aggregation UE to demodulate the signal transmitted by the PCell in the presence of a stronger SCell signal on an adjacent frequency. Throughput is measured on the PCell only.

8.2.1.7.1 Minimum Requirement

For CA the requirements are specified in Table 8.2.1.7.1-2, with the addition of the parameters in Table 8.2.1.7.1-1 and the downlink physical channel setup according to Annex C.3.2.

Table 8.2.1.7.1-1: Test Parameters for CA

Parameter		Unit	Test 1
Downlink power allocation	ρ_A	dB	0
	ρ_B	dB	0 (Note 1)
	σ	dB	0
\hat{E}_{s_PCell} at antenna port of PCell		dBm/15kHz	-85
\hat{E}_{s_SCell} at antenna port of SCell		dBm/15kHz	-79
N_{oc} at antenna port		dBm/15kHz	Off (Note 2)
Symbols for unused PRBs			OCNG (Note 3)
Modulation			64 QAM
Maximum number of HARQ transmission			1
Redundancy version coding sequence			{0}
PDSCH transmission mode of PCell			1
PDSCH transmission mode of SCell			3
Note 1: $P_B = 0$.			
Note 2: No external noise sources are applied			
Note 3: These physical resource blocks are assigned to an arbitrary number of virtual UEs with one PDSCH per virtual UE; the data transmitted over the OCNG PDSCHs shall be uncorrelated pseudo random data.			
Note 4: Void			

Table 8.2.1.7.1-2: Minimum performance (FRC) for CA

Test Number	Band-width	Reference Channel		OCNG Pattern		Propagation Conditions		Correlation Matrix and Antenna		Reference value Fraction of Maximum Throughput (%)		UE Category
		PCell	SCell	PCell	SCell	PCell	SCell	PCell	SCell	PCell	SCell	
1	2x20M Hz	R.49 FDD	NA	OP.1 FDD	OP.5 FDD	Clause B.1	Clause B.1	1x2	2x2	85%	NA	≥5
Note 1: The OCNG pattern for PCell is used to fill the control channel. The OCNG pattern for SCell is used to fill the control channel and PDSCH.												
Note 2: The applicability of requirements for different CA configurations and bandwidth combination sets is defined in 8.1.2.3.												

8.2.2 TDD (Fixed Reference Channel)

The parameters specified in Table 8.2.2-1 are valid for all TDD tests unless otherwise stated.

Table 8.2.2-1: Common Test Parameters (TDD)

Parameter	Unit	Value
Uplink downlink configuration (Note 1)		1
Special subframe configuration (Note 2)		4
Cyclic prefix		Normal
Cell ID		0
Inter-TTI Distance		1
Number of HARQ processes per component carrier	Processes	7
Maximum number of HARQ transmission		4
Redundancy version coding sequence		{0,1,2,3} for QPSK and 16QAM {0,0,1,2} for 64QAM
Number of OFDM symbols for PDCCH per component carrier	OFDM symbols	4 for 1.4 MHz bandwidth, 3 for 3 MHz and 5 MHz bandwidths, 2 for 10 MHz, 15 MHz and 20 MHz bandwidths
Cross carrier scheduling		Not configured
Note 1: as specified in Table 4.2-2 in TS 36.211 [4].		
Note 2: as specified in Table 4.2-1 in TS 36.211 [4].		

8.2.2.1 Single-antenna port performance

The single-antenna performance in a given multi-path fading environments is determined by the SNR for which a certain relative information bit throughput of the reference measurement channels in Annex A.3.4 is achieved. The purpose of these tests is to verify the single-antenna performance with different channel models and MCS. The QPSK and 64QAM cases are also used to verify the performance for all bandwidths specified in Table 5.6.1-1.

8.2.2.1.1 Minimum Requirement

For single carrier, the requirements are specified in Table 8.2.2.1.1-2, with the addition of the parameters in Table 8.2.2.1.1-1 and the downlink physical channel setup according to Annex C.3.2. For CA the requirements are specified in Table 8.2.2.1.1-4, with the addition of the parameters in Table 8.2.2.1.1-3 and the downlink physical channel setup according to Annex C.3.2.

The test coverage for different number of component carriers is defined in 8.1.2.4.

Table 8.2.2.1.1-1: Test Parameters

Parameter	Unit	Test 1- 5	Test 6- 8	Test 9- 15	Test 16- 18	Test 19
Downlink power allocation	ρ_A	dB	0	0	0	0
	ρ_B	dB	0 (Note 1)	0 (Note 1)	0 (Note 1)	0 (Note 1)
	σ	dB	0	0	0	0

N_{oc} at antenna port	dBm/15kHz	-98	-98	-98	-98	-98
Symbols for unused PRBs		OCNG (Note 2)	OCNG (Note 2)	OCNG (Note 2)	OCNG (Note 2)	OCNG (Note 2)
Modulation		QPSK	16QAM	64QAM	16QAM	QPSK
ACK/NACK feedback mode		Multiplexing	Multiplexing	Multiplexing	Multiplexing	Multiplexing
PDSCH transmission mode		1	1	1	1	1
<p>Note 1: $P_B = 0$</p> <p>Note 2: These physical resource blocks are assigned to an arbitrary number of virtual UEs with one PDSCH per virtual UE; the data transmitted over the OCNG PDSCHs shall be uncorrelated pseudo random data, which is QPSK modulated.</p> <p>Note 3: Void.</p> <p>Note 4: Void.</p>						

Table 8.2.2.1.1-2: Minimum performance (FRC)

Test number	Bandwidth	Reference Channel	OCNG Pattern	Propagation Condition	Correlation Matrix and Antenna Configuration	Reference value		UE Category
						Fraction of Maximum Throughput (%)	SNR (dB)	
1	10 MHz	R.2 TDD	OP.1 TDD	EVA5	1x2 Low	70	-1.2	1-8
2	10 MHz	R.2 TDD	OP.1 TDD	ETU70	1x2 Low	70	-0.6	1-8
3	10 MHz	R.2 TDD	OP.1 TDD	ETU300	1x2 Low	70	-0.2	1-8
4	10 MHz	R.2 TDD	OP.1 TDD	HST	1x2	70	-2.6	1-8
5	1.4 MHz	R.4 TDD	OP.1 TDD	EVA5	1x2 Low	70	0.0	1-8
6	10 MHz	R.3 TDD	OP.1 TDD	EVA5	1x2 Low	70	6.7	2-8
	5 MHz	R.3-1 TDD	OP.1 TDD	EVA5	1x2 Low	70	6.7	1
7	10 MHz	R.3 TDD	OP.1 TDD	ETU70	1x2 Low	30	1.4	2-8
	5 MHz	R.3-1 TDD	OP.1 TDD	ETU70	1x2 Low	30	1.4	1
8	10 MHz	R.3 TDD	OP.1 TDD	ETU300	1x2 High	70	9.3	2-8
	5 MHz	R.3-1 TDD	OP.1 TDD	ETU300	1x2 High	70	9.3	1
9	3 MHz	R.5 TDD	OP.1 TDD	EVA5	1x2 Low	70	17.6	1-8
10	5 MHz	R.6 TDD	OP.1 TDD	EVA5	1x2 Low	70	17.6	2-8
	5 MHz	R.6-1 TDD	OP.1 TDD	EVA5	1x2 Low	70	17.6	1
11	10 MHz	R.7 TDD	OP.1 TDD	EVA5	1x2 Low	70	17.6	2-8
	10 MHz	R.7-1 TDD	OP.1 TDD	EVA5	1x2 Low	70	17.6	1
12	10 MHz	R.7 TDD	OP.1 TDD	ETU70	1x2 Low	70	19.1	2-8
	10 MHz	R.7-1 TDD	OP.1 TDD	ETU70	1x2 Low	70	19.1	1
13	10 MHz	R.7 TDD	OP.1 TDD	EVA5	1x2 High	70	19.1	2-8
	10 MHz	R.7-1 TDD	OP.1 TDD	EVA5	1x2 High	70	19.1	1
14	15 MHz	R.8 TDD	OP.1 TDD	EVA5	1x2 Low	70	17.8	2-8
	15 MHz	R.8-1 TDD	OP.1 TDD	EVA5	1x2 Low	70	17.8	1
15	20 MHz	R.9 TDD	OP.1 TDD	EVA5	1x2 Low	70	17.7	3-8
	20 MHz	R.9-2 TDD	OP.1 TDD	EVA5	1x2 Low	70	17.7	2
	20 MHz	R.9-1 TDD	OP.1 TDD	EVA5	1x2 Low	70	17.7	1
16	3 MHz	R.0 TDD	OP.1 TDD	ETU70	1x2 Low	30	2.1	1-8
17	10 MHz	R.1 TDD	OP.1 TDD	ETU70	1x2 Low	30	2.0	1-8
18	20 MHz	R.1 TDD	OP.1 TDD	ETU70	1x2 Low	30	2.1	1-8
19	10 MHz	R.41 TDD	OP.1 TDD	EVA5	1x2 Low	70	-5.3	1-8
Note 1: Void.								

Table 8.2.2.1.1-3: Test Parameters for CA

Parameter	Unit	Test 1
Downlink power allocation	ρ_A	dB
	ρ_B	dB
		0 (Note 1)

	σ	dB	0
N_{oc} at antenna port		dBm/15kHz	-98
Symbols for unused PRBs			OCNG (Note 2)
Modulation			QPSK
ACK/NACK feedback mode			PUCCH format 1b with channel selection
PDSCH transmission mode			1
Note 1: $P_B = 0$			
Note 2: These physical resource blocks are assigned to an arbitrary number of virtual UEs with one PDSCH per virtual UE; the data transmitted over the OCNG PDSCHs shall be uncorrelated pseudo random data, which is QPSK modulated.			
Note 3: The same PDSCH transmission mode is applied to each component carrier.			

Table 8.2.2.1.1-4: Minimum performance (FRC) for CA

Test number	Bandwidth	Reference Channel	OCNG Pattern	Propagation Condition	Correlation Matrix and Antenna Configuration	Reference value		UE Category
						Fraction of Maximum Throughput (%)	SNR (dB)	
1	2x20MHz	R.42 TDD	OP.1 TDD (Note 1)	EVA5	1x2 Low	70	-1.2	5-8

Note 1: The OCNG pattern applies for each CC.

Note 2: The applicability of requirements for different CA configurations and bandwidth combination sets is defined in 8.1.2.3.

8.2.2.1.2 Void

8.2.2.1.3 Void

8.2.2.1.4 Minimum Requirement 1 PRB allocation in presence of MBSFN

The requirements are specified in Table 8.2.2.1.4-2, with the addition of the parameters in Table 8.2.2.1.1.4-1 and the downlink physical channel setup according to Annex C.3.2. The purpose of these tests is to verify the single-antenna performance with a single PRB allocated at the lower band edge in presence of MBSFN.

Table 8.2.2.1.4-1: Test Parameters for Testing 1 PRB allocation

Parameter	Unit	Test 1	
Downlink power allocation	ρ_A	dB	0
	ρ_B	dB	0 (Note 1)
	σ	dB	0
N_{oc} at antenna port	dBm/15kHz	-98	
Symbols for MBSFN portion of MBSFN subframes (Note 2)		OCNG (Note 3)	
ACK/NACK feedback mode		Multiplexing	
PDSCH transmission mode		1	
Note 1: $P_B = 0$ Note 2: The MBSFN portion of an MBSFN subframe comprises the whole MBSFN subframe except the first two symbols in the first slot. Note 3: The MBSFN portion of the MBSFN subframes shall contain QPSK modulated data. Cell-specific reference signals are not inserted in the MBSFN portion of the MBSFN subframes, QPSK modulated MBSFN data is used instead.			

Table 8.2.2.1.4-2: Minimum performance 1PRB (FRC)

Test number	Bandwidth	Reference Channel	OCNG Pattern	Propagation Condition	Correlation Matrix and Antenna Configuration	Reference value		UE Category
						Fraction of Maximum Throughput (%)	SNR (dB)	
1	10 MHz	R.29 TDD	OP.3 TDD	ETU70	1x2 Low	30	2.0	1-8

8.2.2.2 Transmit diversity performance

8.2.2.2.1 Minimum Requirement 2 Tx Antenna Port

The requirements are specified in Table 8.2.2.2.1-2, with the addition of the parameters in Table 8.2.2.2.1-1 and the downlink physical channel setup according to Annex C.3.2. The purpose is to verify the performance of transmit diversity (SFBC) with 2 transmitter antennas.

Table 8.2.2.2.1-1: Test Parameters for Transmit diversity Performance (FRC)

Parameter	Unit	Test 1-2	
Downlink power allocation	ρ_A	dB	-3
	ρ_B	dB	-3 (Note 1)
	σ	dB	0
N_{oc} at antenna port	dBm/15kHz	-98	
ACK/NACK feedback mode		Multiplexing	
PDSCH transmission mode		2	
Note 1: $P_B = 1$			

Table 8.2.2.1-2: Minimum performance Transmit Diversity (FRC)

Test number	Bandwidth	Reference Channel	OCNG Pattern	Propagation Condition	Correlation Matrix and Antenna Configuration	Reference value		UE Category
						Fraction of Maximum Throughput (%)	SNR (dB)	
1	10 MHz	R.11 TDD	OP.1 TDD	EVA5	2x2 Medium	70	6.8	2-8
	5 MHz	R.11-2 TDD	OP.1 TDD	EVA5	2x2 Medium	70	6.8	1
2	10 MHz	R.10 TDD	OP.1 TDD	HST	2x2	70	-2.3	1-8

8.2.2.2.2 Minimum Requirement 4 Tx Antenna Port

The requirements are specified in Table 8.2.2.2-2, with the addition of the parameters in Table 8.2.2.2-1 and the downlink physical channel setup according to Annex C.3.2. The purpose is to verify the performance of transmit diversity (SFBC-FSTD) with 4 transmitter antennas.

Table 8.2.2.1-1: Test Parameters for Transmit diversity Performance (FRC)

Parameter	Unit	Test 1-2	
Downlink power allocation	ρ_A	dB	-3
	ρ_B	dB	-3 (Note 1)
	σ	dB	0
N_{oc} at antenna port	dBm/15kHz	-98	
ACK/NACK feedback mode		Multiplexing	
PDSCH transmission mode		2	
Note 1: $P_B = 1$			

Table 8.2.2.1-2: Minimum performance Transmit Diversity (FRC)

Test number	Bandwidth	Reference Channel	OCNG Pattern	Propagation Condition	Correlation Matrix and Antenna Configuration	Reference value		UE Category
						Fraction of Maximum Throughput (%)	SNR (dB)	
1	1.4 MHz	R.12 TDD	OP.1 TDD	EPA5	4x2 Medium	70	0.2	1-8
2	10 MHz	R.13 TDD	OP.1 TDD	ETU70	4x2 Low	70	-0.5	1-8

8.2.2.2.3 Minimum Requirement 2 Tx Antenna Port (demodulation subframe overlaps with aggressor cell ABS)

The requirements are specified in Table 8.2.2.2-2, with the addition of parameters in Table 8.2.2.2-1 and the downlink physical channel setup according to Annex C.3.2 and Annex C.3.3. The purpose is to verify the performance of transmit diversity (SFBC) with 2 transmit antennas if the PDSCH transmission in the serving cell takes place in subframes that overlap with ABS [9] of the aggressor cell. In Table 8.2.2.2-1, Cell 1 is the serving cell, and Cell 2 is the aggressor cell. The downlink physical channel setup for Cell 1 is according to Annex C.3.2 and for Cell 2 is according to Annex C.3.3, respectively.

Table 8.2.2.3-1: Test Parameters for Transmit diversity Performance (FRC)

Parameter		Unit	Cell 1	Cell 2
Uplink downlink configuration			1	1
Special subframe configuration			4	4
Downlink power allocation	ρ_A	dB	-3	-3
	ρ_B	dB	-3 (Note 1)	-3 (Note 1)
	σ	dB	0	N/A
N_{oc} at antenna port	N_{oc1}	dBm/15kHz	-102 (Note 2)	N/A
	N_{oc2}	dBm/15kHz	-98 (Note 3)	N/A
	N_{oc3}	dBm/15kHz	-94.8 (Note 4)	N/A
\hat{E}_s / N_{oc2}		dB	Reference Value in Table 8.2.2.3-2	6
$BW_{Channel}$		MHz	10	10
Subframe Configuration			Non-MBSFN	Non-MBSFN
Time Offset between Cells		μs	2.5 (synchronous cells)	
Cell Id			0	1
ABS pattern (Note 5)			N/A	0000010001 0000000001
RLM/RRM Measurement Subframe Pattern (Note 6)			0000000001 0000000001	N/A
CSI Subframe Sets (Note 7)	$C_{CSI,0}$		0000010001 0000000001	N/A
	$C_{CSI,1}$		1100101000 1100111000	N/A
Number of control OFDM symbols			2	2
ACK/NACK feedback mode			Multiplexing	N/A
PDSCH transmission mode			2	N/A
Cyclic prefix			Normal	Normal
<p>Note 1: $P_B = 1$.</p> <p>Note 2: This noise is applied in OFDM symbols #1, #2, #3, #5, #6, #8, #9, #10, #12, #13 of a subframe overlapping with the aggressor ABS.</p> <p>Note 3: This noise is applied in OFDM symbols #0, #4, #7, #11 of a subframe overlapping with the aggressor ABS.</p> <p>Note 4: This noise is applied in all OFDM symbols of a subframe overlapping with aggressor non-ABS.</p> <p>Note 5: ABS pattern as defined in [9].</p> <p>Note 6: Time-domain measurement resource restriction pattern for PCell measurements as defined in [7].</p> <p>Note 7: As configured according to the time-domain measurement resource restriction pattern for CSI measurements defined in [7].</p> <p>Note 8: Cell 1 is the serving cell. Cell 2 is the aggressor cell. The number of the CRS ports in Cell1 and Cell2 is the same.</p> <p>Note 9: SIB-1 will not be transmitted in Cell2 in this test.</p>				

Table 8.2.2.3-2: Minimum Performance Transmit Diversity (FRC)

Test Number	Reference Channel	OCNG Pattern		Propagation Conditions (Note 1)		Correlation Matrix and Antenna Configuration	Reference Value		UE Category
		Cell 1	Cell 2	Cell 1	Cell 2		Fraction of Maximum Throughput (%) (Note 5)	SNR (dB) (Note 2)	
1	R.11-4 TDD (Note 4)	OP.1 TDD	OP.1 TDD	EVA5	EVA5	2x2 Medium	70	3.8	2-8
Note 1: The propagation conditions for Cell 1 and Cell2 are statistically independent. Note 2: SNR corresponds to \widehat{E}_s/N_{oc2} of cell 1. Note 3: The correlation matrix and antenna configuration apply for Cell 1 and Cell 2. Note 4: Cell 1 Reference channel is modified: PDSCH other than SIB1/paging and its associated PDCCH/PCFICH are transmitted in the serving cell subframe when the subframe is overlapped with the ABS subframe of aggressor cell and the subframe is available in the definition of the reference channel. Note 5: The maximum Throughput is calculated from the total Payload in 2 subframes, averaged over 20ms.									

8.2.2.3 Open-loop spatial multiplexing performance

8.2.2.3.1 Minimum Requirement 2 Tx Antenna Port

For single carrier the requirements are specified in Table 8.2.2.3.1-2, with the addition of the parameters in Table 8.2.2.3.1-1 and the downlink physical channel setup according to Annex C.3.2. For CA the requirements are specified in Table 8.2.2.3.1-4, with the addition of the parameters in Table 8.2.2.3.1-3 and the downlink physical channel setup according to Annex C.3.2. The purpose is to verify the performance of large delay CDD with 2 transmitter antennas. The test coverage for different number of component carriers is defined in 8.1.2.4.

Table 8.2.2.3.1-1: Test Parameters for Large Delay CDD (FRC)

Parameter	Unit	Test 1
Downlink power allocation	ρ_A	dB
	ρ_B	dB
	σ	dB
N_{oc} at antenna port	dBm/15kHz	-98
ACK/NACK feedback mode		Bundling
PDSCH transmission mode		3
Note 1: $P_B = 1$		
Note 2: Void.		
Note 3: Void.		

Table 8.2.2.3.1-2: Minimum performance Large Delay CDD (FRC)

Test number	Bandwidth	Reference Channel	OCNG Pattern	Propagation Condition	Correlation Matrix and Antenna Configuration	Reference value		UE Category
						Fraction of Maximum Throughput (%)	SNR (dB)	
1	10 MHz	R.11-1 TDD	OP.1 TDD	EVA70	2x2 Low	70	13.1	2-8
Note 1: Void.								

Table 8.2.2.3.1-3: Test Parameters for Large Delay CDD (FRC) for CA

Parameter		Unit	Test 1
Downlink power allocation	ρ_A	dB	-3
	ρ_B	dB	-3 (Note 1)
	σ	dB	0
N_{oc} at antenna port		dBm/15kHz	-98
ACK/NACK feedback mode			PUCCH format 1b with channel selection
PDSCH transmission mode			3
Note 1: $P_B = 1$			
Note 2: The same PDSCH transmission mode is applied to each component carrier.			

Table 8.2.2.3.1-4: Minimum performance Large Delay CDD (FRC) for CA

Test number	Bandwidth	Reference Channel	OCNG Pattern	Propagation Condition	Correlation Matrix and Antenna Configuration	Reference value		UE Ca
						Fraction of Maximum Throughput (%)	SNR (dB)	
1	2x20 MHz	R.30-1 TDD	OP.1 TDD (Note 1)	EVA70	2x2 Low	70	13.7	5
Note 1: The OCNG pattern applies for each CC.								
Note 2: The applicability of requirements for different CA configurations and bandwidth combination sets is defined in 8.1.2.3.								

8.2.2.3.1A Soft buffer management test

For CA the requirements are specified in Table 8.2.2.3.1A-2, with the addition of the parameters in Table 8.2.2.3.1A-1 and the downlink physical channel setup according to Annex C.3.2. The purpose is to verify UE performance with proper instantaneous buffer implementation.

Table 8.2.2.3.1A-1: Test Parameters for soft buffer management (FRC) for CA

Parameter		Unit	Test 1-2
Downlink power allocation	ρ_A	dB	-3
	ρ_B	dB	-3 (Note 1)
	σ	dB	0
N_{oc} at antenna port		dBm/15kHz	-98
ACK/NACK feedback mode			- (Note 2)
PDSCH transmission mode			3
Note 1: $P_B = 1$			
Note 2: PUCCH format 1b with channel selection is used to feedback ACK/NACK.			
Note 3: For CA test cases, the same PDSCH transmission mode is applied to each component carrier.			

Table 8.2.2.3.1A-2: Minimum performance soft buffer management test (FRC) for CA

Test number	Bandwidth	Reference Channel	OCNG Pattern	Propagation Condition	Correlation Matrix and Antenna Configuration	Reference value		UE Category	cap
						Fraction of Maximum Throughput (%)	SNR (dB)		
1	2x20 MHz	R.30-2 TDD	OP.1 TDD (Note 1)	EVA70	2x2 Low	70	13.2	3	(
2	2x20 MHz	R.35-1 TDD	OP.1 TDD (Note 1)	EVA5	2x2 Low	70	15.7	4	(

Note 1: For CA test cases, the OCNG pattern applies for each CC.
Note 2: The applicability of requirements for different CA configurations and bandwidth combination sets is defined in 8.1.2.3.

8.2.2.3.2 Minimum Requirement 4 Tx Antenna Port

The requirements are specified in Table 8.2.2.3.2-2, with the addition of the parameters in Table 8.2.2.3.2-1 and the downlink physical channel setup according to Annex C.3.2. The purpose is to verify the performance of large delay CDD with 4 transmitter antennas.

Table 8.2.2.3.2-1: Test Parameters for Large Delay CDD (FRC)

Parameter	Unit	Test 1
Downlink power allocation	ρ_A	dB
	ρ_B	dB
	σ	dB
N_{oc} at antenna port	dBm/15kHz	-98
ACK/NACK feedback mode		Bundling
PDSCH transmission mode		3
Note 1: $P_B = 1$.		

Table 8.2.2.3.2-2: Minimum performance Large Delay CDD (FRC)

Test number	Bandwidth	Reference Channel	OCNG Pattern	Propagation Condition	Correlation Matrix and Antenna Configuration	Reference value		UE Category
						Fraction of Maximum Throughput (%)	SNR (dB)	
1	10 MHz	R.14 TDD	OP.1 TDD	EVA70	4x2 Low	70	14.2	2-8

8.2.2.3.3 Minimum Requirement 2Tx antenna port (demodulation subframe overlaps with aggressor cell ABS)

The requirements for non-MBSFN ABS are specified in Table 8.2.2.3.3-2, with the addition of parameters in Table 8.2.2.3.3-1 and the downlink physical channel setup according to Annex C.3.2 and Annex C.3.3.

The requirements for MBSFN ABS are specified in Table 8.2.2.3.3-4, with the addition of parameters in Table 8.2.2.3.3-3 and the downlink physical channel setup according to Annex C.3.2 and Annex C.3.3.

The purpose is to verify the performance of large delay CDD with 2 transmitter antennas if the PDSCH transmission in the serving cell takes place in subframes that overlap with ABS [9] of the aggressor cell. In Tables 8.2.2.3.3-1 and 8.2.2.3.3-3, Cell 1 is the serving cell, and Cell 2 is the aggressor cell. The downlink physical channel setup for Cell 1 is according to Annex C.3.2 and for Cell 2 is according to Annex C.3.3, respectively.

Table 8.2.2.3.3-1: Test Parameters for Large Delay CDD (FRC) – Non-MBSFN ABS

Parameter	Unit	Cell 1	Cell 2
Uplink downlink configuration		1	1
Special subframe configuration		4	4
Downlink power allocation	ρ_A	dB	-3
	ρ_B	dB	-3 (Note 1)
	σ	dB	0
N_{oc} at antenna port	N_{oc1}	dBm/15kHz	-102 (Note 2)
	N_{oc2}	dBm/15kHz	-98 (Note 3)
	N_{oc3}	dBm/15kHz	-94.8 (Note 4)
\widehat{E}_s/N_{oc2}	dB	Reference Value in Table 8.2.2.3.3-2	6
$BW_{Channel}$	MHz	10	10
Subframe Configuration		Non-MBSFN	Non-MBSFN
Cell Id		0	1
Time Offset between Cells	μs	2.5 (synchronous cells)	
ABS pattern (Note 5)		N/A	0000010001, 0000000001
RLM/RRM Measurement Subframe Pattern (Note 6)		0000000001, 0000000001	N/A
CSI Subframe Sets (Note 7)	$C_{CSI,0}$	0000010001, 0000000001	N/A
	$C_{CSI,1}$	1100101000 1100111000	N/A
Number of control OFDM symbols		2	2
ACK/NACK feedback mode		Multiplexing	N/A
PDSCH transmission mode		3	N/A
Cyclic prefix		Normal	Normal
<p>Note 1: $P_B = 1$.</p> <p>Note 2: This noise is applied in OFDM symbols #1, #2, #3, #5, #6, #8, #9, #10, #12, #13 of a subframe overlapping with the aggressor ABS.</p> <p>Note 3: This noise is applied in OFDM symbols #0, #4, #7, #11 of a subframe overlapping with the aggressor ABS.</p> <p>Note 4: This noise is applied in all OFDM symbols of a subframe overlapping with aggressor non-ABS.</p> <p>Note 5: ABS pattern as defined in [9].</p> <p>Note 6: Time-domain measurement resource restriction pattern for PCell measurements as defined in [7].</p> <p>Note 7: As configured according to the time-domain measurement resource restriction pattern for CSI measurements defined in [7].</p> <p>Note 8: Cell 1 is the serving cell. Cell 2 is the aggressor cell. The number of the CRS ports in Cell1 and Cell2 is the same.</p> <p>Note 9: SIB-1 will not be transmitted in Cell2 in this test.</p>			

Table 8.2.2.3.3-2: Minimum Performance Large Delay CDD (FRC) – Non-MBSFN ABS

Test Number	Reference Channel	OCNG Pattern		Propagation Conditions (Note 1)		Correlation Matrix and Antenna Configuration	Reference Value		UE Category
		Cell 1	Cell 2	Cell 1	Cell 2		Fraction of Maximum Throughput (%) (Note 5)	SNR (dB) (Note 2)	
1	R.11 TDD (Note 4)	OP.1 TDD	OP.1 TDD	EVA 5	EVA 5	2x2 Low	70	14.0	2-8
<p>Note 1: The propagation conditions for Cell 1 and Cell2 are statistically independent.</p> <p>Note 2: SNR corresponds to \hat{E}_s / N_{oc2} of cell 1.</p> <p>Note 3: The correlation matrix and antenna configuration apply for Cell 1 and Cell 2.</p> <p>Note 4: Cell 1 Reference channel is modified: PDSCH other than SIB1/paging and its associated PDCCH/PCFICH are transmitted in the serving cell subframe when the subframe is overlapped with the ABS subframe of aggressor cell and the subframe is available in the definition of the reference channel.</p> <p>Note 5: The maximum Throughput is calculated from the total Payload in 2 subframes, averaged over 20ms.</p>									

Table 8.2.2.3.3-3: Test Parameters for Large Delay CDD (FRC) – MBSFN ABS

Parameter	Unit	Cell 1	Cell 2
Uplink downlink configuration		1	1
Special subframe configuration		4	4
Downlink power allocation	ρ_A	dB	-3
	ρ_B	dB	-3 (Note 1)
	σ	dB	0
N_{oc} at antenna port	N_{oc1}	dBm/15kHz	-102 (Note 2)
	N_{oc2}	dBm/15kHz	-98 (Note 3)
	N_{oc3}	dBm/15kHz	-94.8 (Note 4)
\widehat{E}_s/N_{oc2}	dB	Reference Value in Table 8.2.2.3.3-4	6
$BW_{Channel}$	MHz	10	10
Subframe Configuration		Non-MBSFN	MBSFN
Cell Id		0	126
Time Offset between Cells	μs	2.5 (synchronous cells)	
ABS pattern (Note 5)		N/A	0000000001 0000000001
RLM/RRM Measurement Subframe Pattern (Note 6)		0000000001 0000000001	N/A
CSI Subframe Sets (Note 7)	$C_{CSI,0}$	0000000001 0000000001	N/A
	$C_{CSI,1}$	1100111000 1100111000	N/A
MBSFN Subframe Allocation (Note 10)		N/A	000010
Number of control OFDM symbols		2	2
ACK/NACK feedback mode		Multiplexing	N/A
PDSCH transmission mode		3	N/A
Cyclic prefix		Normal	Normal
<p>Note 1: $P_B = 1$.</p> <p>Note 2: This noise is applied in OFDM symbols #1, #2, #3, #4, #5, #6, #7, #8, #9, #10, #11, #12, #13 of a subframe overlapping with the aggressor ABS.</p> <p>Note 3: This noise is applied in OFDM symbol #0 of a subframe overlapping with the aggressor ABS.</p> <p>Note 4: This noise is applied in all OFDM symbols of a subframe overlapping with aggressor non-ABS.</p> <p>Note 5: ABS pattern as defined in [9]. The 10th and 20th subframes indicated by ABS pattern are MBSFN ABS subframes.</p> <p>Note 6: Time-domain measurement resource restriction pattern for PCell measurements as defined in [7]</p> <p>Note 7: As configured according to the time-domain measurement resource restriction pattern for CSI measurements defined in [7].</p> <p>Note 8: Cell 1 is the serving cell. Cell 2 is the aggressor cell. The number of the CRS ports in Cell1 and Cell2 is the same.</p> <p>Note 9: SIB-1 will not be transmitted in Cell2 in this test.</p> <p>Note 10: MBSFN Subframe Allocation as defined in [7], one frame with 6 bits is chosen for MBSFN subframe allocation.</p>			

Table 8.2.2.3.3-4: Minimum Performance Large Delay CDD (FRC) – MBSFN ABS

Test Number	Reference Channel	OCNG Pattern		Propagation Conditions (Note 1)		Correlation Matrix and Antenna Configuration	Reference Value		UE Category
		Cell 1	Cell 2	Cell 1	Cell 2		Fraction of Maximum Throughput (%) (Note 5)	SNR (dB) (Note 2)	
1	R.11 TDD (Note 4)	OP.1 TDD	OP.1 TDD	EVA 5	EVA 5	2x2 Low	70	12.2	2-8
Note 1: The propagation conditions for Cell 1 and Cell2 are statistically independent. Note 2: SNR corresponds to \hat{E}_s / N_{oc2} of cell 1. Note 3: The correlation matrix and antenna configuration apply for Cell 1 and Cell 2. Note 4: Cell 1 Reference channel is modified: PDSCH other than SIB1/paging and its associated PDCCH/PCFICH are transmitted in the serving cell subframe when the subframe is overlapped with the ABS subframe of aggressor cell and the subframe is available in the definition of the reference channel. Note 5: The maximum Throughput is calculated from the total Payload in 2 subframes, averaged over 20ms.									

8.2.2.4 Closed-loop spatial multiplexing performance

8.2.2.4.1 Minimum Requirement Single-Layer Spatial Multiplexing 2 Tx Antenna Port

The requirements are specified in Table 8.2.2.4.1-2, with the addition of the parameters in Table 8.2.2.4.1-1 and the downlink physical channel setup according to Annex C.3.2. The purpose of these tests is to verify the closed loop rank-one performance with wideband and frequency selective precoding.

Table 8.2.2.4.1-1: Test Parameters for Single-Layer Spatial Multiplexing (FRC)

Parameter	Unit	Test 1	Test 2
Downlink power allocation	ρ_A	dB	-3
	ρ_B	dB	-3 (Note 1)
	σ	dB	0
N_{oc} at antenna port	dBm/15kHz	-98	-98
Precoding granularity	PRB	6	50
PMI delay (Note 2)	ms	10 or 11	10 or 11
Reporting interval	ms	1 or 4 (Note 3)	1 or 4 (Note 3)
Reporting mode		PUSCH 1-2	PUSCH 3-1
CodeBookSubsetRestriction bitmap		001111	001111
ACK/NACK feedback mode		Multiplexing	Multiplexing
PDSCH transmission mode		4	4
Note 1: $P_B = 1$. Note 2: If the UE reports in an available uplink reporting instance at subframe SF#n based on PMI estimation at a downlink SF not later than SF#(n-4), this reported PMI cannot be applied at the eNB downlink before SF#(n+4). Note 3: For Uplink - downlink configuration 1 the reporting interval will alternate between 1ms and 4ms.			

Table 8.2.2.4.1-2: Minimum performance Single-Layer Spatial Multiplexing (FRC)

Test number	Bandwidth	Reference Channel	OCNG Pattern	Propagation Condition	Correlation Matrix and Antenna Configuration	Reference value		UE Category
						Fraction of Maximum Throughput (%)	SNR (dB)	
1	10 MHz	R.10 TDD	OP.1 TDD	EVA5	2x2 Low	70	-3.1	1-8
2	10 MHz	R.10 TDD	OP.1 TDD	EPA5	2x2 High	70	-2.8	1-8

8.2.2.4.1A Minimum Requirement Single-Layer Spatial Multiplexing 4 Tx Antenna Port

The requirements are specified in Table 8.2.2.4.1A-2, with the addition of the parameters in Table 8.2.2.4.1A-1 and the downlink physical channel setup according to Annex C.3.2. The purpose of these tests is to verify the closed loop rank-one performance with wideband and frequency selective precoding.

Table 8.2.2.4.1A-1: Test Parameters for Single-Layer Spatial Multiplexing (FRC)

Parameter	Unit	Test 1
Downlink power allocation	ρ_A	dB
	ρ_B	dB
	σ	dB
N_{oc} at antenna port	dBm/15kHz	-98
Precoding granularity	PRB	6
PMI delay (Note 2)	ms	10 or 11
Reporting interval	ms	1 or 4 (Note 3)
Reporting mode		PUSCH 1-2
CodeBookSubsetRestriction bitmap		0000000000000000 0000000000000000 0000000000000011 11111111111111
ACK/NACK feedback mode		Multiplexing
PDSCH transmission mode		4
Note 1: $P_B = 1$. Note 2: If the UE reports in an available uplink reporting instance at subframe SF#n based on PMI estimation at a downlink SF not later than SF#(n-4), this reported PMI cannot be applied at the eNB downlink before SF#(n+4). Note 3: For Uplink - downlink configuration 1 the reporting interval will alternate between 1ms and 4ms.		

Table 8.2.2.4.1A-2: Minimum performance Single-Layer Spatial Multiplexing (FRC)

Test number	Bandwidth	Reference Channel	OCNG Pattern	Propagation Condition	Correlation Matrix and Antenna Configuration	Reference value		UE Category
						Fraction of Maximum Throughput (%)	SNR (dB)	
1	10 MHz	R.13 TDD	OP.1 TDD	EVA5	4x2 Low	70	-3.5	1-8

8.2.2.4.2 Minimum Requirement Multi-Layer Spatial Multiplexing 2 Tx Antenna Port

The requirements are specified in Table 8.2.2.4.2-2, with the addition of the parameters in Table 8.2.2.4.2-1 and the downlink physical channel setup according to Annex C.3.2. The purpose of these tests is to verify the closed loop rank-two performance with wideband and frequency selective precoding.

Table 8.2.2.4.2-1: Test Parameters for Multi-Layer Spatial Multiplexing (FRC)

Parameter		Unit	Test 1-2
Downlink power allocation	ρ_A	dB	-3
	ρ_B	dB	-3 (Note 1)
	σ	dB	0
N_{oc} at antenna port		dBm/15kHz	-98
Precoding granularity		PRB	50
PMI delay (Note 2)		ms	10 or 11
Reporting interval		ms	1 or 4 (Note 3)
Reporting mode			PUSCH 3-1
ACK/NACK feedback mode			Bundling
CodeBookSubsetRestriction bitmap			110000
PDSCH transmission mode			4
Note 1: $P_B = 1$.			
Note 2: If the UE reports in an available uplink reporting instance at subframe SF#n based on PMI estimation at a downlink SF not later than SF#(n-4), this reported PMI cannot be applied at the eNB downlink before SF#(n+4).			
Note 3: For Uplink - downlink configuration 1 the reporting interval will alternate between 1ms and 4ms.			

Table 8.2.2.4.2-2: Minimum performance Multi-Layer Spatial Multiplexing (FRC)

Test number	Bandwidth	Reference Channel	OCNG Pattern	Propagation Condition	Correlation Matrix and Antenna Configuration	Reference value		UE Category
						Fraction of Maximum Throughput (%)	SNR (dB)	
1	10 MHz	R.35 TDD	OP.1 TDD	EPA5	2x2 Low	70	19.5	2-8
2	10 MHz	R.11-1 TDD	OP.1 TDD	ETU70	2x2 Low	70	13.9	2-8

8.2.2.4.3 Minimum Requirement Multi-Layer Spatial Multiplexing 4 Tx Antenna Port

For single carrier the requirements are specified in Table 8.2.2.4.3-2, with the addition of the parameters in Table 8.2.2.4.3-1 and the downlink physical channel setup according to Annex C.3.2. For CA the requirements are specified in Table 8.2.2.4.3-2, with the addition of the parameters in Table 8.2.2.4.3-1 and the downlink physical channel setup according to Annex C.3.2. The purpose of these tests is to verify the closed loop rank-two performance with wideband and frequency selective precoding.

The test coverage for different number of component carriers is defined in 8.1.2.4.

Table 8.2.2.4.3-1: Test Parameters for Multi-Layer Spatial Multiplexing (FRC)

Parameter		Unit	Test 1
Downlink power allocation	ρ_A	dB	-6
	ρ_B	dB	-6 (Note 1)
	σ	dB	3

N_{oc} at antenna port	dBm/15kHz	-98
Precoding granularity	PRB	6
PMI delay (Note 2)	ms	10 or 11
Reporting interval	ms	1 or 4 (Note 3)
Reporting mode		PUSCH 1-2
ACK/NACK feedback mode		Bundling
CodeBookSubsetRestriction bitmap		000000000000 000000000000 000000111111 111111111000 000000000000
PDSCH transmission mode		4
<p>Note 1: $P_B = 1$.</p> <p>Note 2: If the UE reports in an available uplink reporting instance at subframe SF#n based on PMI estimation at a downlink SF not later than SF#(n-4), this reported PMI cannot be applied at the eNB downlink before SF#(n+4).</p> <p>Note 3: For Uplink - downlink configuration 1 the reporting interval will alternate between 1ms and 4ms.</p> <p>Note 4: Void.</p> <p>Note 5: Void.</p> <p>Note 6: Void.</p>		

Table 8.2.2.4.3-2: Minimum performance Multi-Layer Spatial Multiplexing (FRC)

Test number	Bandwidth	Reference Channel	OCNG Pattern	Propagation Condition	Correlation Matrix and Antenna Configuration	Reference value		UE Category
						Fraction of Maximum Throughput (%)	SNR (dB)	
1	10 MHz	R.36 TDD	OP.1 TDD	EPA5	4x2 Low	70	15.7	2-8
Note 1: Void.								

Table 8.2.2.4.3-3: Test Parameters for Multi-Layer Spatial Multiplexing (FRC) for CA

Parameter	Unit	Test 1
Downlink power allocation	ρ_A	dB
	ρ_B	dB
	σ	dB
N_{oc} at antenna port	dBm/15kHz	-98
Precoding granularity	PRB	8
PMI delay (Note 2)	ms	10 or 11
Reporting interval	ms	1 or 4 (Note 3)
Reporting mode		PUSCH 1-2
ACK/NACK feedback mode		PUCCH format 1b with channel selection
CodeBookSubsetRestriction bitmap		000000000000000000000000 0000111111111111111110000000 00000000
CSI request field (Note 4)		'10'
PDSCH transmission mode		4
<p>Note 1: $P_B = 1$.</p> <p>Note 2: If the UE reports in an available uplink reporting instance at subframe SF#n based on PMI estimation at a downlink SF not later than SF#(n-4), this reported PMI cannot be applied at the eNB downlink before SF#(n+4)</p> <p>Note 3: For Uplink - downlink configuration 1 the reporting interval will alternate between 1ms and 4ms.</p> <p>Note 4: Multiple CC-s under test are configured as the 1st set of serving cells by high layers.</p> <p>Note 5: The same PDSCH transmission mode is applied to each component carrier.</p>		

Table 8.2.2.4.3-4: Minimum performance Multi-Layer Spatial Multiplexing (FRC) for CA

Test number	Bandwidth	Reference Channel	OCNG Pattern	Propagation Condition	Correlation Matrix and Antenna Configuration	Reference value		UE Category
						Fraction of Maximum Throughput (%)	SNR (dB)	
1	2x20 MHz	R.43 TDD	OP.1 TDD (Note 1)	EVA5	4x2 Low	70	11.1	5-8
Note 1:	The OCNG pattern applies for each CC.							
Note 2:	The applicability of requirements for different CA configurations and bandwidth combination sets is defined in 8.1.2.3.							

8.2.2.5 MU-MIMO

8.2.2.6 [Control channel performance: D-BCH and PCH]

8.2.2.7 Carrier aggregation with power imbalance

The requirements in this section verify the ability of an intraband adjacent carrier aggregation UE to demodulate the signal transmitted by the PCell in the presence of a stronger SCell signal on an adjacent frequency. Throughput is measured on the PCell only.

8.2.2.7.1 Minimum Requirement

For CA the requirements are specified in Table 8.2.2.7.1-2, with the addition of the parameters in Table 8.2.2.7.1-1 and the downlink physical channel setup according to Annex C.3.2.

Table 8.2.2.7.1-1: Test Parameters for CA

Parameter	Unit	Test 1	
Downlink power allocation	ρ_A	dB	0
	ρ_B	dB	0 (Note 1)
	σ	dB	0
\hat{E}_s_{PCell} at antenna port of PCell	dBm/15kHz	-85	
\hat{E}_s_{SCell} at antenna port of SCell	dBm/15kHz	-79	
N_{oc} at antenna port	dBm/15kHz	Off (Note 2)	
Symbols for unused PRBs		OCNG (Note 3)	
Modulation		64 QAM	
Maximum number of HARQ transmission		1	
Redundancy version coding sequence		{0}	
PDSCH transmission mode of PCell		1	
PDSCH transmission mode of SCell		3	
Note 1: $P_B = 0$. Note 2: No external noise sources are applied. Note 3: These physical resource blocks are assigned to an arbitrary number of virtual UEs with one PDSCH per virtual UE; the data transmitted over the OCNG PDSCHs shall be uncorrelated pseudo random data.			

Table 8.2.2.7.1-2: Minimum performance (FRC) for CA

Test Number	Bandwidth	Reference Channel		OCNG Pattern		Propagation Conditions		Correlation Matrix and Antenna		Reference value Fraction of Maximum Throughput (%)		UE Category
		PCell	SCell	PCell	SCell	PCell	SCell	PCell	SCell	PCell	SCell	
1	2x20M Hz	R.49 TDD	NA	OP.1 TDD	OP.5 TDD	Clause B.1	Clause B.1	1x2	2x2	85%	NA	≥5
Note 1: The OCNG pattern for PCell is used to fill the control channel. The OCNG pattern for SCell is used to fill the control channel and PDSCH. Note 2: The applicability of requirements for different CA configurations and bandwidth combination sets is defined in 8.1.2.3.												

8.3 Demodulation of PDSCH (User-Specific Reference Symbols)

8.3.1 FDD

The parameters specified in Table 8.3.1-1 are valid for FDD unless otherwise stated.

Table 8.3.1-1: Common Test Parameters for User-specific Reference Symbols

Parameter	Unit	Value
Cyclic prefix		Normal
Cell ID		0
Inter-TTI Distance		1
Number of HARQ processes	Processes	8
Maximum number of HARQ transmission		4
Redundancy version coding sequence		{0,1,2,3} for QPSK and 16QAM {0,0,1,2} for 64QAM
Number of OFDM symbols for PDCCH	OFDM symbols	2
Precoder update granularity		Frequency domain: 1 PRG for Transmission mode 9 Time domain: 1 ms
Note 1: Void		
Note 2: Void		

8.3.1.1 Single-layer Spatial Multiplexing

For single-layer transmission on antenna ports 7 or 8 upon detection of a PDCCH with DCI format 2C, the requirements are specified in Table 8.3.1.1-1 and 8.3.1.1-2, with the addition of the parameters in Table 8.3.1.1-3 and the downlink physical channel setup according to Annex C.3.2. The purpose of these tests is to verify rank-1 performance on one of the antenna ports 7 or 8 with and without a simultaneous transmission on the other antenna port, and to verify rate matching with multiple CSI reference symbol configurations with non-zero and zero transmission power.

Table 8.3.1.1-1: Test Parameters for Testing CDM-multiplexed DM RS (single layer) with multiple CSI-RS configurations

parameter	Unit	Test 1	Test 2	
Downlink power allocation	ρ_A	dB	0	0
	ρ_B	dB	0 (Note 1)	0 (Note 1)
	σ	dB	-3	-3
Cell-specific reference signals		Antenna ports 0,1		
CSI reference signals		Antenna ports 15,...,18	Antenna ports 15,...,18	
Beamforming model		Annex B.4.1	Annex B.4.1	
CSI-RS periodicity and subframe offset $T_{\text{CSI-RS}} / \Delta_{\text{CSI-RS}}$	Subframes	5 / 2	5 / 2	
CSI reference signal configuration		0	3	
Zero-power CSI-RS configuration $I_{\text{CSI-RS}} / \text{ZeroPowerCSI-RS}$ bitmap	Subframes / bitmap	3 / 0001000000000000	3 / 0001000000000000	
N_{oc} at antenna port	dBm/15kHz	-98	-98	
Symbols for unused PRBs		OCNG (Note 4)	OCNG (Note 4)	
Number of allocated resource blocks (Note 2)	PRB	50	50	
Simultaneous transmission		No	Yes (Note 3, 5)	
PDSCH transmission mode		9	9	
<p>Note 1: $P_B = 1$.</p> <p>Note 2: The modulation symbols of the signal under test are mapped onto antenna port 7 or 8.</p> <p>Note 3: Modulation symbols of an interference signal is mapped onto the antenna port (7 or 8) not used for the input signal under test.</p> <p>Note 4: These physical resource blocks are assigned to an arbitrary number of virtual UEs with one PDSCH per virtual UE; the data transmitted over the OCNG PDSCHs shall be uncorrelated pseudo random data, which is QPSK modulated.</p> <p>Note 5: The two UEs' scrambling identities n_{SCID} are set to 0 for CDM-multiplexed DM RS with interfering simultaneous transmission test cases.</p>				

Table 8.3.1.1-2: Minimum performance for CDM-multiplexed DM RS without simultaneous transmission (FRC) with multiple CSI-RS configurations

Test number	Bandwidth and MCS	Reference Channel	OCNG Pattern	Propagation Condition	Correlation Matrix and Antenna Configuration	Reference value		UE Category
						Fraction of Maximum Throughput (%)	SNR (dB)	
1	10 MHz QPSK 1/3	R.43 FDD	OP.1 FDD	EVA5	2x2 Low	70	-1	1-8

Table 8.3.1.1-3: Minimum performance for CDM-multiplexed DM RS with interfering simultaneous transmission (FRC) with multiple CSI-RS configurations

Test number	Bandwidth and MCS	Reference Channel	OCNG Pattern	Propagation Condition	Correlation Matrix and Antenna Configuration	Reference value		UE Category
						Fraction of Maximum Throughput (%)	SNR (dB)	
2	10 MHz 64QAM 1/2	R.50 FDD	OP.1 FDD	EPA5	2x2 Low	70	21.9	2-8

Note 1: The reference channel applies to both the input signal under test and the interfering signal.

8.3.1.2 Dual-Layer Spatial Multiplexing

For dual-layer transmission on antenna ports 7 and 8 upon detection of a PDCCH with DCI format 2C, the requirements are specified in Table 8.3.1.2-2, with the addition of the parameters in Table 8.3.1.2-1 and the downlink physical channel setup according to Annex C.3.2. The purpose of these tests is to verify the rank-2 performance for full RB allocation, and to verify rate matching with multiple CSI reference symbol configurations with non-zero and zero transmission power.

Table 8.3.1.2-1: Test Parameters for Testing CDM-multiplexed DM RS (dual layer) with multiple CSI-RS configurations

parameter	Unit	Test 1	
Downlink power allocation	ρ_A	dB	0
	ρ_B	dB	0 (Note 1)
	σ	dB	-3
Cell-specific reference signals		Antenna ports 0 and 1	
CSI reference signals		Antenna ports 15,16	
Beamforming model		Annex B.4.2	
CSI-RS periodicity and subframe offset $T_{\text{CSI-RS}} / \Delta_{\text{CSI-RS}}$	Subframes	5 / 2	
CSI reference signal configuration		8	
Zero-power CSI-RS configuration $I_{\text{CSI-RS}} / \text{ZeroPowerCSI-RS}$ bitmap	Subframes / bitmap	3 / 0010000000000000	
N_{oc} at antenna port	dBm/15kHz	-98	
Symbols for unused PRBs		OCNG (Note 2)	
Number of allocated resource blocks (Note 2)	PRB	50	
Simultaneous transmission		No	
PDSCH transmission mode		9	
Note 1: $P_B = 1$ Note 2: These physical resource blocks are assigned to an arbitrary number of virtual UEs with one PDSCH per virtual UE; the data transmitted over the OCNG PDSCHs shall be uncorrelated pseudo random data, which is QPSK modulated.			

Table 8.3.1.2-2: Minimum performance for CDM-multiplexed DM RS (FRC) with multiple CSI-RS configurations

Test number	Bandwidth and MCS	Reference Channel	OCNG Pattern	Propagation Condition	Correlation Matrix and Antenna Configuration	Reference value		UE Category
						Fraction of Maximum Throughput (%)	SNR (dB)	
1	10 MHz 16QAM 1/2	R.51 FDD	OP.1 FDD	EPA5	2x2 Low	70	13.3	2-8

8.3.2 TDD

The parameters specified in Table 8.3.2-1 are valid for TDD unless otherwise stated.

Table 8.3.2-1: Common Test Parameters for User-specific Reference Symbols

Parameter	Unit	Value
Uplink downlink configuration (Note 1)		1
Special subframe configuration (Note 2)		4
Cyclic prefix		Normal
Cell ID		0
Inter-TTI Distance		1
Number of HARQ processes	Processes	7
Maximum number of HARQ transmission		4
Redundancy version coding sequence		{0,1,2,3} for QPSK and 16QAM {0,0,1,2} for 64QAM
Number of OFDM symbols for PDCCH	OFDM symbols	2
Precoder update granularity		Frequency domain: 1 PRB for Transmission mode 8, 1 PRG for Transmission mode 9 Time domain: 1 ms
ACK/NACK feedback mode		Multiplexing
Note 1: as specified in Table 4.2-2 in TS 36.211 [4]		
Note 2: as specified in Table 4.2-1 in TS 36.211 [4]		

8.3.2.1 Single-layer Spatial Multiplexing

For single-layer transmission on antenna port 5, the requirements are specified in Table 8.3.2.1-2, with the addition of the parameters in Table 8.3.2.1-1 and the downlink physical channel setup according to Annex C.3.2. The purpose is to verify the demodulation performance using user-specific reference signals with full RB or single RB allocation.

Table 8.3.2.1-1: Test Parameters for Testing DRS

Parameter		Unit	Test 1	Test 2	Test 3	Test 4
Downlink power allocation	ρ_A	dB	0	0	0	0
	ρ_B	dB	0 (Note 1)	0 (Note 1)	0 (Note 1)	0 (Note 1)
	σ	dB	0	0	0	0
Cell-specific reference signals			Antenna port 0			
Beamforming model			Annex B.4.1			
N_{oc} at antenna port		dB/15kHz	-98	-98	-98	-98
Symbols for unused PRBs			OCNG (Note 2)	OCNG (Note 2)	OCNG (Note 2)	OCNG (Note 2)
PDSCH transmission mode			7	7	7	7
Note 1: $P_B = 0$.						
Note 2: These physical resource blocks are assigned to an arbitrary number of virtual UEs with one PDSCH per virtual UE; the data transmitted over the OCNG PDSCHs shall be uncorrelated pseudo random data, which is QPSK modulated.						

Table 8.3.2.1-2: Minimum performance DRS (FRC)

Test number	Bandwidth and MCS	Reference Channel	OCNG Pattern	Propagation Condition	Correlation Matrix and Antenna Configuration	Reference value		UE Category
						Fraction of Maximum Throughput (%)	SNR (dB)	
1	10 MHz QPSK 1/3	R.25 TDD	OP.1 TDD	EPA5	2x2 Low	70	-0.8	1-5
2	10 MHz 16QAM 1/2	R.26 TDD	OP.1 TDD	EPA5	2x2 Low	70	7.0	2-5
	5MHz 16QAM 1/2	R.26-1 TDD	OP.1 TDD	EPA5	2x2 Low	70	7.0	1
3	10 MHz 64QAM 3/4	R.27 TDD	OP.1 TDD	EPA5	2x2 Low	70	17.0	2-5
	10 MHz 64QAM 3/4	R.27-1 TDD	OP.1 TDD	EPA5	2x2 Low	70	17.0	1
4	10 MHz 16QAM 1/2	R.28 TDD	OP.1 TDD	EPA5	2x2 Low	30	1.7	1-5

For single-layer transmission on antenna ports 7 or 8 upon detection of a PDCCH with DCI format 2B, the requirements are specified in Table 8.3.2.1-4 and 8.3.2.1-5, with the addition of the parameters in Table 8.3.2.1-3 and the downlink physical channel setup according to Annex C.3.2. The purpose of these tests is to verify rank-1 performance on one of the antenna ports 7 or 8 with and without a simultaneous transmission on the other antenna port.

Table 8.3.2.1-3: Test Parameters for Testing CDM-multiplexed DM RS (single layer)

Parameter		Unit	Test 1	Test 2	Test 3	Test 4	Test 5
Downlink power allocation	ρ_A	dB	0	0	0	0	0
	ρ_B	dB	0 (Note 1)	0 (Note 1)	0 (Note 1)	0 (Note 1)	0 (Note 1)
	σ	dB	-3	-3	-3	-3	-3
Cell-specific reference signals			Antenna port 0 and antenna port 1				
Beamforming model			Annex B.4.1				
N_{oc} at antenna port		dBm/15kHz	-98	-98	-98	-98	-98
Symbols for unused PRBs			OCNG (Note 4)	OCNG (Note 4)	OCNG (Note 4)	OCNG (Note 4)	OCNG (Note 4)
Simultaneous transmission			No	No	No	Yes (Note 3, 5)	Yes (Note 3, 5)
PDSCH transmission mode			8	8	8	8	8
<p>Note 1: $P_B = 1$.</p> <p>Note 2: The modulation symbols of the signal under test is mapped onto antenna port 7 or 8.</p> <p>Note 3: Modulation symbols of an interference signal is mapped onto the antenna port (7 or 8) not used for the input signal under test.</p> <p>Note 4: These physical resource blocks are assigned to an arbitrary number of virtual UEs with one PDSCH per virtual UE; the data transmitted over the OCNG PDSCHs shall be uncorrelated pseudo random data, which is QPSK modulated.</p> <p>Note 5: The two UEs' scrambling identities n_{SCID} are set to 0 for CDM-multiplexed DM RS with interfering simultaneous transmission test cases.</p>							

Table 8.3.2.1-4: Minimum performance for CDM-multiplexed DM RS without simultaneous transmission (FRC)

Test number	Bandwidth and MCS	Reference Channel	OCNG Pattern	Propagation Condition	Correlation Matrix and Antenna Configuration	Reference value		UE Category
						Fraction of Maximum Throughput (%)	SNR (dB)	
1	10 MHz QPSK 1/3	R.31 TDD	OP.1 TDD	EVA5	2x2 Low	70	-1.0	1-5
2	10 MHz 16QAM 1/2	R.32 TDD	OP.1 TDD	EPA5	2x2 Medium	70	7.7	2-5
	5MHz 16QAM 1/2	R.32-1 TDD	OP.1 TDD	EPA5	2x2 Medium	70	7.7	1
3	10 MHz 64QAM 3/4	R.33 TDD	OP.1 TDD	EPA5	2x2 Low	70	17.7	2-5
	10 MHz 64QAM 3/4	R.33-1 TDD	OP.1 TDD	EPA5	2x2 Low	70	17.7	1

Table 8.3.2.1-5: Minimum performance for CDM-multiplexed DM RS with interfering simultaneous transmission (FRC)

Test number	Bandwidth and MCS	Reference Channel	OCNG Pattern	Propagation Condition	Correlation Matrix and Antenna Configuration	Reference value		UE Category
						Fraction of Maximum Throughput (%)	SNR (dB)	
4	10 MHz 16QAM 1/2	R.32 TDD (Note 1)	OP.1 TDD	EPA5	2x2 Medium	70	21.9	2-5
5	10 MHz 64QAM 1/2	R.34 TDD (Note 1)	OP.1 TDD	EPA5	2x2 Low	70	22.0	2-5
Note 1: The reference channel applies to both the input signal under test and the interfering signal.								

8.3.2.1A Single-layer Spatial Multiplexing (with multiple CSI-RS configurations)

For single-layer transmission on antenna ports 7 or 8 upon detection of a PDCCH with DCI format 2C, the requirements are specified in Table 8.3.2.1A-2 and 8.3.2.1A-3, with the addition of the parameters in Table 8.3.2.1A-1 and the downlink physical channel setup according to Annex C.3.2. The purpose of these tests is to verify rank-1 performance on one of the antenna ports 7 or 8 with and without a simultaneous transmission on the other antenna port, and to verify rate matching with multiple CSI reference symbol configurations with non-zero and zero transmission power.

Table 8.3.2.1A-1: Test Parameters for Testing CDM-multiplexed DM RS (single layer) with multiple CSI-RS configurations

Parameter	Unit	Test 1	Test 2
Downlink power allocation	ρ_A	dB	0
	ρ_B	dB	0 (Note 1)
	σ	dB	-3
Cell-specific reference signals		Antenna ports 0,1	
CSI reference signals		Antenna ports 15,...,22	Antenna ports 15,...,18
Beamforming model		Annex B.4.1	Annex B.4.1
CSI-RS periodicity and subframe offset $T_{\text{CSI-RS}} / \Delta_{\text{CSI-RS}}$	Subframes	5 / 4	5 / 4
CSI reference signal configuration		1	3
Zero-power CSI-RS configuration $l_{\text{CSI-RS}} / \text{ZeroPowerCSI-RS}$ bitmap	Subframes / bitmap	4 / 0010000100000000	4 / 0010000000000000
N_{oc} at antenna port	dBm/15kHz	-98	-98
Symbols for unused PRBs		OCNG (Note 4)	OCNG (Note 4)
Number of allocated resource blocks (Note 2)	PRB	50	50
Simultaneous transmission		No	Yes (Note 3, 5)
PDSCH transmission mode		9	9
Note 1: $P_B = 1$. Note 2: The modulation symbols of the signal under test are mapped onto antenna port 7 or 8. Note 3: Modulation symbols of an interference signal is mapped onto the antenna port (7 or 8) not used for the input signal under test. Note 4: These physical resource blocks are assigned to an arbitrary number of virtual UEs with one PDSCH per virtual UE; the data transmitted over the OCNG PDSCHs shall be uncorrelated pseudo random data, which is QPSK modulated. Note 5: The two UEs' scrambling identities n_{SCID} are set to 0 for CDM-multiplexed DM RS with interfering simultaneous transmission test cases.			

Table 8.3.2.1A-2: Minimum performance for CDM-multiplexed DM RS without simultaneous transmission (FRC) with multiple CSI-RS configurations

Test number	Bandwidth and MCS	Reference Channel	OCNG Pattern	Propagation Condition	Correlation Matrix and Antenna Configuration	Reference value		UE Category
						Fraction of Maximum Throughput (%)	SNR (dB)	
1	10 MHz QPSK 1/3	R.50 TDD	OP.1 TDD	EVA5	2x2 Low	70	-0.6	1-8

Table 8.3.2.1A-3: Minimum performance for CDM-multiplexed DM RS with interfering simultaneous transmission (FRC) with multiple CSI-RS configurations

Test number	Bandwidth and MCS	Reference Channel	OCNG Pattern	Propagation Condition	Correlation Matrix and Antenna Configuration	Reference value		UE Category
						Fraction of Maximum Throughput (%)	SNR (dB)	
2	10 MHz 64QAM 1/2	R.44 TDD	OP.1 TDD	EPA5	2x2 Low	70	22.1	2-8

Note 1: The reference channel applies to both the input signal under test and the interfering signal.

8.3.2.2 Dual-Layer Spatial Multiplexing

For dual-layer transmission on antenna ports 7 and 8 upon detection of a PDCCH with DCI format 2B, the requirements are specified in Table 8.3.2.2-2, with the addition of the parameters in Table 8.3.2.2-1 and the downlink physical channel setup according to Annex C.3.2. The purpose of these tests is to verify the rank-2 performance for full RB allocation.

Table 8.3.2.2-1: Test Parameters for Testing CDM-multiplexed DM RS (dual layer)

Parameter		Unit	Test 1	Test 2
Downlink power allocation	ρ_A	dB	0	0
	ρ_B	dB	0 (Note 1)	0 (Note 1)
	σ	dB	-3	-3
Cell-specific reference symbols			Antenna port 0 and antenna port 1	
Beamforming model			Annex B.4.2	
N_{oc} at antenna port		dBm/15kHz	-98	-98
Symbols for unused PRBs			OCNG (Note 2)	OCNG (Note 2)
Number of allocated resource blocks		PRB	50	50
PDSCH transmission mode			8	8
Note 1: $P_B = 1$.				
Note 2: These physical resource blocks are assigned to an arbitrary number of virtual UEs with one PDSCH per virtual UE; the data transmitted over the OCNG PDSCHs shall be uncorrelated pseudo random data, which is QPSK modulated.				

Table 8.3.2.2-2: Minimum performance for CDM-multiplexed DM RS (FRC)

Test number	Bandwidth and MCS	Reference Channel	OCNG Pattern	Propagation Condition	Correlation Matrix and Antenna Configuration	Reference value		UE Category
						Fraction of Maximum Throughput (%)	SNR (dB)	
1	10 MHz QPSK 1/3	R.31 TDD	OP.1 TDD	EVA5	2x2 Low	70	4.5	2-5
2	10 MHz 16QAM 1/2	R.32 TDD	OP.1 TDD	EPA5	2x2 Medium	70	21.7	2-5

8.3.2.3 Dual-Layer Spatial Multiplexing (with multiple CSI-RS configurations)

For dual-layer transmission on antenna ports 7 and 8 upon detection of a PDCCH with DCI format 2C, the requirements are specified in Table 8.3.2.3-2, with the addition of the parameters in Table 8.3.2.3-1 and the downlink physical channel setup according to Annex C.3.2. The purpose of these tests is to verify the rank-2 performance for full RB allocation, and to verify rate matching with multiple CSI reference symbol configurations with non-zero and zero transmission power.

Table 8.3.2.3-1: Test Parameters for Testing CDM-multiplexed DM RS (dual layer) with multiple CSI-RS configurations

parameter	Unit	Test 1
Downlink power allocation	ρ_A	dB
	ρ_B	dB
	σ	dB
Cell-specific reference signals		Antenna ports 0 and 1
CSI reference signals		Antenna ports 15,16
Beamforming model		Annex B.4.2
CSI-RS periodicity and subframe offset $T_{\text{CSI-RS}} / \Delta_{\text{CSI-RS}}$	Subframes	5 / 4
CSI reference signal configuration		8
Zero-power CSI-RS configuration $I_{\text{CSI-RS}} / \text{ZeroPowerCSI-RS}$ bitmap	Subframes / bitmap	4 / 0010000000000000
N_{oc} at antenna port	dBm/15kHz	-98
Symbols for unused PRBs		OCNG (Note 2)
Number of allocated resource blocks (Note 2)	PRB	50
Simultaneous transmission		No
PDSCH transmission mode		9
Note 1: $P_B = 1$		
Note 2: These physical resource blocks are assigned to an arbitrary number of virtual UEs with one PDSCH per virtual UE; the data transmitted over the OCNG PDSCHs shall be uncorrelated pseudo random data, which is QPSK modulated.		

Table 8.3.2.3-2: Minimum performance for CDM-multiplexed DM RS (FRC) with multiple CSI-RS configurations

Test number	Bandwidth and MCS	Reference Channel	OCNG Pattern	Propagation Condition	Correlation Matrix and Antenna Configuration	Reference value		UE Category
						Fraction of Maximum Throughput (%)	SNR (dB)	
1	10 MHz 16QAM 1/2	R.51 TDD	OP.1 TDD	EPA5	2x2 Low	70	14.5	2-8

8.4 Demodulation of PDCCH/PCFICH

The receiver characteristics of the PDCCH/PCFICH are determined by the probability of miss-detection of the Downlink Scheduling Grant (Pm-dsg). PDCCH and PCFICH are tested jointly, i.e. a miss detection of PCFICH implies a miss detection of PDCCH.

8.4.1 FDD

The parameters specified in Table 8.4.1-1 are valid for all FDD tests unless otherwise stated.

Table 8.4.1-1: Test Parameters for PDCCH/PCFICH

Parameter		Unit	Single antenna port	Transmit diversity
Number of PDCCH symbols		symbols	2	2
PHICH Ng (Note 1)			1	1
PHICH duration			Normal	Normal
Unused RE-s and PRB-s			OCNG	OCNG
Cell ID			0	0
Downlink power allocation	PDCCH_RA PHICH_RA OCNG_RA	dB	0	-3
	PCFICH_RB PDCCH_RB PHICH_RB OCNG_RB	dB	0	-3
	N_{oc} at antenna port	dBm/15kHz	-98	-98
	Cyclic prefix		Normal	Normal
Note 1: According to Clause 6.9 in TS 36.211 [4]				

8.4.1.1 Single-antenna port performance

For the parameters specified in Table 8.4.1-1 the average probability of a missed downlink scheduling grant (Pm-dsg) shall be below the specified value in Table 8.4.1.1-1. The downlink physical setup is in accordance with Annex C.3.2.

Table 8.4.1.1-1: Minimum performance PDCCH/PCFICH

Test number	Bandwidth	Aggregation level	Reference Channel	OCNG Pattern	Propagation Condition	Antenna configuration and correlation Matrix	Reference value	
							Pm-dsg (%)	SNR (dB)
1	10 MHz	8 CCE	R.15 FDD	OP.1 FDD	ETU70	1x2 Low	1	-1.7

8.4.1.2 Transmit diversity performance

8.4.1.2.1 Minimum Requirement 2 Tx Antenna Port

For the parameters specified in Table 8.4.1-1 the average probability of a missed downlink scheduling grant (Pm-dsg) shall be below the specified value in Table 8.4.1.2.1-1. The downlink physical setup is in accordance with Annex C.3.2.

Table 8.4.1.2.1-1: Minimum performance PDCCH/PCFICH

Test number	Bandwidth	Aggregation level	Reference Channel	OCNG Pattern	Propagation Condition	Antenna configuration and correlation Matrix	Reference value	
							Pm-dsg (%)	SNR (dB)
1	10 MHz	4 CCE	R.16 FDD	OP.1 FDD	EVA70	2 x 2 Low	1	-0.6

8.4.1.2.2 Minimum Requirement 4 Tx Antenna Port

For the parameters specified in Table 8.4.1-1 the average probability of a missed downlink scheduling grant (Pm-dsg) shall be below the specified value in Table 8.4.1.2.2-1. The downlink physical setup is in accordance with Annex C.3.2.

Table 8.4.1.2.2-1: Minimum performance PDCCH/PCFICH

Test number	Bandwidth	Aggregation level	Reference Channel	OCNG Pattern	Propagation Condition	Antenna configuration and correlation Matrix	Reference value	
							Pm-dsg (%)	SNR (dB)
1	5 MHz	2 CCE	R.17 FDD	OP.1 FDD	EPA5	4 x 2 Medium	1	6.3

8.4.1.2.3 Minimum Requirement 2 Tx Antenna Port (demodulation subframe overlaps with aggressor cell ABS)

For the parameters for non-MBSFN ABS specified in Table 8.4.1-1 and Table 8.4.1.2.3-1, the average probability of a missed downlink scheduling grant (Pm-dsg) shall be below the specified value in Table 8.4.1.2.3-2. The downlink physical setup is in accordance with Annex C.3.2. and Annex C.3.3. In Table 8.4.1.2.3-1, Cell 1 is the serving cell, and Cell 2 is the aggressor cell. The downlink physical channel setup for Cell 1 is according to Annex C.3.2 and for Cell 2 is according to Annex C.3.3, respectively.

For the parameters for MBSFN ABS specified in Table 8.4.1-1 and Table 8.4.1.2.3-3, the average probability of a missed downlink scheduling grant (Pm-dsg) shall be below the specified value in Table 8.4.1.2.3-4. In Table 8.4.1.2.3-3, Cell 1 is the serving cell, and Cell 2 is the aggressor cell. The downlink physical channel setup for Cell 1 is according to Annex C.3.2 and for Cell 2 is according to Annex C.3.3, respectively.

Table 8.4.1.2.3-1: Test Parameters for PDCCH/PCFICH – Non-MBSFN ABS

Parameter		Unit	Cell 1	Cell 2
Downlink power allocation	PDCCH_RA PHICH_RA OCNG_RA	dB	-3	-3
	PCFICH_RB PDCCH_RB PHICH_RB OCNG_RB	dB	-3	-3
N_{oc} at antenna port	N_{oc1}	dBm/15kHz	-100.5 (Note 1)	N/A
	N_{oc2}	dBm/15kHz	-98 (Note 2)	N/A
	N_{oc3}	dBm/15kHz	-95.3 (Note 3)	N/A
\hat{E}_s/N_{oc2}		dB	Reference Value in Table 8.4.1.2.3-2	1.5
BW _{Channel}		MHz	10	10
Subframe Configuration			Non-MBSFN	Non-MBSFN
Time Offset between Cells		μs	2.5 (synchronous cells)	
Cell Id			0	1
ABS pattern (Note 4)			N/A	00000100 00000100 00000100 01000100 00000100
RLM/RRM Measurement Subframe Pattern (Note 5)			00000100 00000100 00000100 00000100	N/A
CSI Subframe Sets (Note 6)	$C_{csi,0}$		00000100 00000100 00000100 01000100 00000100	N/A
	$C_{csi,1}$		11111011 11111011 11111011 10111011 11111011	N/A
Number of control OFDM symbols			3	3
PHICH Ng (Note 9)			1	N/A
PHICH duration			extended	N/A
Unused RE-s and PRB-s			OCNG	OCNG
Cyclic prefix			Normal	Normal
<p>Note 1: This noise is applied in OFDM symbols #1, #2, #3, #5, #6, #8, #9, #10, #12, #13 of a subframe overlapping with the aggressor ABS.</p> <p>Note 2: This noise is applied in OFDM symbols #0, #4, #7, #11 of a subframe overlapping with the aggressor ABS.</p> <p>Note 3: This noise is applied in all OFDM symbols of a subframe overlapping with aggressor non-ABS</p> <p>Note 4: ABS pattern as defined in [9]. PDCCH/PCFICH other than that associated with SIB1/Paging are transmitted in the serving cell subframe when the subframe is overlapped with the ABS subframe of aggressor cell.</p> <p>Note 5: Time-domain measurement resource restriction pattern for PCell measurements as defined in [7];</p> <p>Note 6: As configured according to the time-domain measurement resource restriction pattern for CSI measurements defined in [7];</p> <p>Note 7: Cell 1 is the serving cell. Cell 2 is the aggressor cell. The number of the CRS ports in Cell1 and Cell2 is the same.</p> <p>Note 8: SIB-1 will not be transmitted in Cell2 in the test</p> <p>Note 9: According to Clause 6.9 in TS 36.211 [4].</p>				

Table 8.4.1.2.3-2: Minimum performance PDCCH/PCFICH – Non-MBSFN ABS

Test Number	Aggregation Level	Reference Channel	OCNG Pattern		Propagation Conditions (Note 1)		Correlation Matrix and Antenna Configuration	Reference Value	
			Cell 1	Cell 2	Cell 1	Cell 2		Pm-dsg (%)	SNR (dB) (Note 2)
1	8 CCE	R15-1 FDD	OP.1 FDD	OP.1 FDD	EVA5	EVA5	2x2 Low	1	-3.9
Note 1: The propagation conditions for Cell 1 and Cell 2 are statistically independent. Note 2: SNR corresponds to \hat{E}_s / N_{oc2} of cell 1. Note 3: The correlation matrix and antenna configuration apply for Cell 1 and Cell 2.									

Table 8.4.1.2.3-3: Test Parameters for PDCCH/PCFICH – MBSFN ABS

Parameter		Unit	Cell 1	Cell 2
Downlink power allocation	PDCCH_RA PHICH_RA OCNG_RA	dB	-3	-3
	PCFICH_RB PDCCH_RB PHICH_RB OCNG_RB	dB	-3	-3
N_{oc} at antenna port	N_{oc1}	dBm/15kHz	-100.5 (Note 1)	N/A
	N_{oc2}	dBm/15kHz	-98 (Note 2)	N/A
	N_{oc3}	dBm/15kHz	-95.3 (Note 3)	N/A
\hat{E}_s / N_{oc2}		dB	Reference Value in Table 8.4.1.2.3-4	1.5
$BW_{Channel}$		MHz	10	10
Subframe Configuration			Non-MBSFN	MBSFN
Time Offset between Cells		μ s	2.5 (synchronous cells)	
Cell Id			0	126
ABS pattern (Note 4)			N/A	0001000000 0100000010 0000001000 0000000000
[RLM/RRM Measurement Subframe Pattern (Note 5)]			0001000000 0100000010 0000001000 0000000000	N/A
CSI Subframe Sets (Note 6)	$C_{CSI,0}$		0001000000 0100000010 0000001000 0000000000	N/A
	$C_{CSI,1}$		1110111111 1011111101 1111110111 1111111111	N/A
MBSFN Subframe Allocation (Note 9)			N/A	001000 100001 000100 000000
Number of control OFDM symbols			3	3
PHICH Ng (Note 11)			1	N/A
PHICH duration			extended	N/A
Unused RE-s and PRB-s			OCNG	OCNG
Cyclic prefix			Normal	Normal

Note 1:	This noise is applied in OFDM symbols #1, #2, #3, #4, #5, #6, #7, #8, #9, #10, #11, #12, #13 of a subframe overlapping with the aggressor ABS.
Note 2:	This noise is applied in OFDM symbols #0 of a subframe overlapping with the aggressor ABS.
Note 3:	This noise is applied in all OFDM symbols of a subframe overlapping with aggressor non-ABS
Note 4:	ABS pattern as defined in [9]. The 4 th , 12 th , 19 th and 27 th subframes indicated by ABS pattern are MBSFN ABS subframes. PDSCH other than SIB1/paging and its associated PDCCH/PCFICH are transmitted in the serving cell subframe when the subframe is overlapped with the MBSFN ABS subframe of aggressor cell and the subframe is available in the definition of the reference channel.
Note 5:	Time-domain measurement resource restriction pattern for PCell measurements as defined in [7].
Note 6:	As configured according to the time-domain measurement resource restriction pattern for CSI measurements defined in [7].
Note 7:	Cell 1 is the serving cell. Cell 2 is the aggressor cell. The number of the CRS ports in Cell1 and Cell2 is the same.
Note 8:	SIB-1 will not be transmitted in Cell2 in this test.
Note 9:	MBSFN Subframe Allocation as defined in [7], four frames with 24 bits is chosen for MBSFN subframe allocation.
Note 10:	The maximum number of uplink HARQ transmission is ≤ 2 so that each PHICH channel transmission is in a subframe protected by MBSFN ABS in this test.
Note 11:	According to Clause 6.9 in TS 36.211 [4]

Table 8.4.1.2.3-4: Minimum performance PDCCH/PCHICH – MBSFN ABS

Test Number	Aggregation Level	Reference Channel	OCNG Pattern		Propagation Conditions (Note 1)		Correlation Matrix and Antenna Configuration	Reference Value	
			Cell 1	Cell 2	Cell 1	Cell 2		Pm-dsg (%)	SNR (dB) (Note 2)
1	8 CCE	R15-1 FDD	OP.1 FDD	OP.1 FDD	EVA5	EVA5	2x2 Low	1	-4.2
Note 1: The propagation conditions for Cell 1 and Cell2 are statistically independent. Note 2: SNR corresponds to \hat{E}_s / N_{oc2} of cell 1. Note 3: The correlation matrix and antenna configuration apply for Cell 1 and Cell 2.									

8.4.2 TDD

The parameters specified in Table 8.4.2-1 are valid for all TDD tests unless otherwise stated.

Table 8.4.2-1: Test Parameters for PDCCH/PCFICH

Parameter		Unit	Single antenna port	Transmit diversity
Uplink downlink configuration (Note 1)			0	0
Special subframe configuration (Note 2)			4	4
Number of PDCCH symbols		symbols	2	2
PHICH Ng (Note 3)			1	1
PHICH duration			Normal	Normal
Unused RE-s and PRB-s			OCNG	OCNG
Cell ID			0	0
Downlink power allocation	PDCCH_RA PHICH_RA OCNG_RA	dB	0	-3
	PCFICH_RB PDCCH_RB PHICH_RB OCNG_RB	dB	0	-3
N_{oc} at antenna port		dBm/15kHz	-98	-98
Cyclic prefix			Normal	Normal
ACK/NACK feedback mode			Multiplexing	Multiplexing
Note 1: as specified in Table 4.2-2 in TS 36.211 [4].				
Note 2: as specified in Table 4.2-1 in TS 36.211 [4].				
Note 3: According to Clause 6.9 in TS 36.211 [4]				

8.4.2.1 Single-antenna port performance

For the parameters specified in Table 8.4.2-1 the average probability of a missed downlink scheduling grant (Pm-dsg) shall be below the specified value in Table 8.4.2.1-1. The downlink physical setup is in accordance with Annex C.3.2.

Table 8.4.2.1-1: Minimum performance PDCCH/PCFICH

Test number	Bandwidth	Aggregation level	Reference Channel	OCNG Pattern	Propagation Condition	Antenna configuration and correlation Matrix	Reference value	
							Pm-dsg (%)	SNR (dB)
1	10 MHz	8 CCE	R.15 TDD	OP.1 TDD	ETU70	1x2 Low	1	-1.6

8.4.2.2 Transmit diversity performance

8.4.2.2.1 Minimum Requirement 2 Tx Antenna Port

For the parameters specified in Table 8.4.2-1 the average probability of a missed downlink scheduling grant (Pm-dsg) shall be below the specified value in Table 8.4.2.2.1-1. The downlink physical setup is in accordance with Annex C.3.2.

Table 8.4.2.2.1-1: Minimum performance PDCCH/PCFICH

Test number	Bandwidth	Aggregation level	Reference Channel	OCNG Pattern	Propagation Condition	Antenna configuration and correlation Matrix	Reference value	
							Pm-dsg (%)	SNR (dB)
1	10 MHz	4 CCE	R.16 TDD	OP.1 TDD	EVA70	2 x 2 Low	1	0.1

8.4.2.2.2 Minimum Requirement 4 Tx Antenna Port

For the parameters specified in Table 8.4.2-1 the average probability of a missed downlink scheduling grant (Pm-dsg) shall be below the specified value in Table 8.4.2.2.2-1. The downlink physical setup is in accordance with Annex C.3.2.

Table 8.4.2.2.2-1: Minimum performance PDCCH/PCFICH

Test number	Bandwidth	Aggregation level	Reference Channel	OCNG Pattern	Propagation Condition	Antenna configuration and correlation Matrix	Reference value	
							Pm-dsg (%)	SNR (dB)
1	5 MHz	2 CCE	R.17 TDD	OP.1 TDD	EPA5	4 x 2 Medium	1	6.5

8.4.2.2.3 Minimum Requirement 2 Tx Antenna Port (demodulation subframe overlaps with aggressor cell ABS)

For the parameters for non-MBSFN ABS specified in Table 8.4.2-1 and Table 8.4.2.2.3-1, the average probability of a missed downlink scheduling grant (Pm-dsg) shall be below the specified value in Table 8.4.2.2.3-2. The downlink physical setup is in accordance with Annex C.3.2. and Annex C.3.3.. In Table 8.4.2.2.3-1, Cell 1 is the serving cell, and Cell 2 is the aggressor cell. The downlink physical channel setup for Cell 1 is according to Annex C.3.2 and for Cell 2 is according to Annex C.3.3, respectively.

For the parameters for MBSFN ABS specified in Table 8.4.2-1 and Table 8.4.2.2.3-3, the average probability of a missed downlink scheduling grant (Pm-dsg) shall be below the specified value in Table 8.4.2.2.3-4. In Table 8.4.2.2.3-3, Cell 1 is the serving cell, and Cell 2 is the aggressor cell. The downlink physical channel setup for Cell 1 is according to Annex C.3.2 and for Cell 2 is according to Annex C.3.3, respectively.

Table 8.4.2.2.3-1: Test Parameters for PDCCH/PCFICH – Non-MBSFN ABS

Parameter		Unit	Cell 1	Cell 2
Uplink downlink configuration			1	1
Special subframe configuration			4	4
Downlink power allocation	PDCCH_RA PHICH_RA OCNG_RA	dB	-3	-3
	PCFICH_RB PDCCH_RB PHICH_RB OCNG_RB	dB	-3	-3
N_{oc} at antenna port	N_{oc1}	dBm/15kHz	-100.5 (Note 1)	N/A
	N_{oc2}	dBm/15kHz	-98 (Note 2)	N/A
	N_{oc3}	dBm/15kHz	-95.3 (Note 3)	N/A
\hat{E}_s / N_{oc2}		dB	Reference Value in Table 8.4.2.2.3-2	1.5
$BW_{Channel}$		MHz	10	10
Subframe Configuration			Non-MBSFN	Non-MBSFN
Time Offset between Cells		μ s	2.5 (synchronous cells)	
Cell Id			0	1
ABS pattern (Note 4)			N/A	0000010001 0000000001
RLM/RRM Measurement Subframe Pattern (Note 5)			0000000001 0000000001	N/A
CSI Subframe Sets (Note 6)	$C_{CSI,0}$		0000010001 0000000001	N/A
	$C_{CSI,1}$		1100101000 1100111000	N/A
Number of control OFDM symbols			3	3
ACK/NACK feedback mode			Multiplexing	N/A
PHICH Ng (Note 9)			1	N/A
PHICH duration			extended	N/A
Unused RE-s and PRB-s			OCNG	OCNG
Cyclic prefix			Normal	Normal
Note 1:	This noise is applied in OFDM symbols #1, #2, #3, #5, #6, #8, #9, #10, #12, #13 of a subframe overlapping with the aggressor ABS.			
Note 2:	This noise is applied in OFDM symbols #0, #4, #7, #11 of a subframe overlapping with the aggressor ABS.			
Note 3:	This noise is applied in OFDM symbols of a subframe overlapping with aggressor non-ABS			
Note 4:	ABS pattern as defined in [9]. PDCCH/PCFICH other than that associated with SIB1/Paging are transmitted in the serving cell subframe when the subframe is overlapped with the ABS subframe of aggressor cell.			
Note 5:	Time-domain measurement resource restriction pattern for PCell measurements as defined in [7].			
Note 6:	As configured according to the time-domain measurement resource restriction pattern for CSI measurements defined in [7].			
Note 7:	Cell 1 is the serving cell. Cell 2 is the aggressor cell. The number of the CRS ports in Cell1 and Cell2 is the same.			
Note 8:	SIB-1 will not be transmitted in Cell2 in the test			
Note 9:	According to Clause 6.9 in TS 36.211 [4].			

Table 8.4.2.2.3-2: Minimum performance PDCCH/PCFICH – Non-MBSFN ABS

Test Number	Aggregation Level	Reference Channel	OCNG Pattern		Propagation Conditions (Note 1)		Correlation Matrix and Antenna Configuration	Reference Value	
			Cell 1	Cell 2	Cell 1	Cell 2		Pm-dsg (%)	SNR (dB) (Note 2)
1	8 CCE	R15-1 TDD	OP.1 TDD	OP.1 TDD	EVA5	EVA5	2x2 Low	1	-3.9
<p>Note 1: The propagation conditions for Cell 1 and Cell 2 are statistically independent.</p> <p>Note 2: SNR corresponds to \hat{E}_s / N_{oc2} of cell 1.</p> <p>Note 3: The correlation matrix and antenna configuration apply for Cell 1 and Cell 2.</p>									

Table 8.4.2.2.3-3: Test Parameters for PDCCH/PCFICH – MBSFN ABS

Parameter		Unit	Cell 1	Cell 2
Uplink downlink configuration			1	1
Special subframe configuration			4	4
Downlink power allocation	PDCCH_RA PHICH_RA OCNG_RA	dB	-3	-3
	PCFICH_RB PDCCH_RB PHICH_RB OCNG_RB	dB	-3	-3
N_{oc} at antenna port	N_{oc1}	dBm/15kHz	-100.5 (Note 1)	N/A
	N_{oc2}	dBm/15kHz	-98 (Note 2)	N/A
	N_{oc3}	dBm/15kHz	-95.3 (Note 3)	N/A
\hat{E}_s / N_{oc2}		dB	Reference Value in Table 8.4.2.2.3-4	1.5
$BW_{Channel}$		MHz	10	10
Subframe Configuration			Non-MBSFN	MBSFN
Time Offset between Cells		μ s	2.5 (synchronous cells)	
Cell Id			0	126
ABS pattern (Note 4)			N/A	000000001 000000001
RLM/RRM Measurement Subframe Pattern(Note 5)			000000001 000000001	N/A
CSI Subframe Sets(Note 6)	$C_{CSI,0}$		000000001 000000001	N/A
	$C_{CSI,1}$		1100111000 1100111000	N/A
MBSFN Subframe Allocation (Note 9)			N/A	000010
Number of control OFDM symbols			3	3
ACK/NACK feedback mode			Multiplexing	N/A
PHICH Ng (Note 10)			1	N/A
PHICH duration			extended	N/A
Unused RE-s and PRB-s			OCNG	OCNG
Cyclic prefix			Normal	Normal
Note 1:	This noise is applied in OFDM symbols #1, #2, #3, #4, #5, #6, #7, #8, #9, #10, #11, #12, #13 of a subframe overlapping with the aggressor ABS.			
Note 2:	This noise is applied in OFDM symbols #0 of a subframe overlapping with the aggressor ABS.			
Note 3:	This noise is applied in OFDM symbols of a subframe overlapping with aggressor non-ABS			
Note 4:	ABS pattern as defined in [9]. The 10 th and 20 th subframes indicated by ABS pattern are MBSFN ABS subframes. PDSCH other than SIB1/paging and its associated PDCCH/PCFICH are transmitted in the serving cell subframe when the subframe is overlapped with the MBSFN ABS subframe of aggressor cell and the subframe is available in the definition of the reference channel.			
Note 5:	Time-domain measurement resource restriction pattern for PCell measurements as defined in [7].			
Note 6:	As configured according to the time-domain measurement resource restriction pattern for CSI measurements defined in [7].			
Note 7:	Cell 1 is the serving cell. Cell 2 is the aggressor cell. The number of the CRS ports in Cell1 and Cell2 is the same.			
Note 8:	SIB-1 will not be transmitted in Cell2 in this test.			
Note 9:	MBSFN Subframe Allocation as defined in [7], one frame with 6 bits is chosen for MBSFN subframe allocation.			
Note 10:	According to Clause 6.9 in TS 36.211 [4]			

Table 8.4.2.2.3-4: Minimum performance PDCCH/PCFICH – MBSFN ABS

Test Number	Aggregation Level	Reference Channel	OCNG Pattern		Propagation Conditions (Note 1)		Correlation Matrix and Antenna Configuration	Reference Value	
			Cell 1	Cell 2	Cell 1	Cell 2		Pm-dsg (%)	SNR (dB) (Note 2)
1	8 CCE	R15-1 TDD	OP.1 TDD	OP.1 TDD	EVA5	EVA5	2x2 Low	1	-4.1

Note 1: The propagation conditions for Cell 1 and Cell2 are statistically independent.

Note 2: SNR corresponds to \hat{E}_s / N_{oc2} of cell 1.

Note 3: The correlation matrix and antenna configuration apply for Cell 1 and Cell 2.

8.5 Demodulation of PHICH

The receiver characteristics of the PHICH are determined by the probability of miss-detecting an ACK for a NACK (Pm-an). It is assumed that there is no bias applied to the detection of ACK and NACK (zero-threshold detection).

8.5.1 FDD

The parameters specified in Table 8.5.1-1 are valid for all FDD tests unless otherwise stated.

Table 8.5.1-1: Test Parameters for PHICH

Parameter		Unit	Single antenna port	Transmit diversity
Downlink power allocation	PDCCH_RA PHICH_RA OCNG_RA	dB	0	-3
	PCFICH_RB PDCCH_RB PHICH_RB OCNG_RB	dB	0	-3
PHICH duration			Normal	Normal
PHICH Ng (Note 1)			Ng = 1	Ng = 1
PDCCH Content			UL Grant should be included with the proper information aligned with A.3.6.	
Unused RE-s and PRB-s			OCNG	OCNG
Cell ID			0	0
N_{oc} at antenna port		dBm/15kHz	-98	-98
Cyclic prefix			Normal	Normal

Note 1: according to Clause 6.9 in TS 36.211 [4]

8.5.1.1 Single-antenna port performance

For the parameters specified in Table 8.5.1-1 the average probability of a miss-detecting ACK for NACK (Pm-an) shall be below the specified value in Table 8.5.1.1-1. The downlink physical setup is in accordance with Annex C.3.2.

Table 8.5.1.1-1: Minimum performance PHICH

Test number	Bandwidth	Reference Channel	OCNG Pattern	Propagation Condition	Antenna configuration and correlation Matrix	Reference value	
						Pm-an (%)	SNR (dB)
1	10 MHz	R.18	OP.1 FDD	ETU70	1 x 2 Low	0.1	5.5
2	10 MHz	R.24	OP.1 FDD	ETU70	1 x 2 Low	0.1	0.6

8.5.1.2 Transmit diversity performance

8.5.1.2.1 Minimum Requirement 2 Tx Antenna Port

For the parameters specified in Table 8.5.1-1 the average probability of a miss-detecting ACK for NACK (P_{m-an}) shall be below the specified value in Table 8.5.1.2-1. The downlink physical setup is in accordance with Annex C.3.2.

Table 8.5.1.2.1-1: Minimum performance PHICH

Test number	Bandwidth	Reference Channel	OCNG Pattern	Propagation Condition	Antenna configuration and correlation Matrix	Reference value	
						Pm-an (%)	SNR (dB)
1	10 MHz	R.19	OP.1 FDD	EVA70	2 x 2 Low	0.1	4.4

8.5.1.2.2 Minimum Requirement 4 Tx Antenna Port

For the parameters specified in Table 8.5.1-1 the average probability of a miss-detecting ACK for NACK (P_{m-an}) shall be below the specified value in Table 8.5.1.2.2-1. The downlink physical setup is in accordance with Annex C.3.2.

Table 8.5.1.2.2-1: Minimum performance PHICH

Test number	Bandwidth	Reference Channel	OCNG Pattern	Propagation Condition	Antenna configuration and correlation Matrix	Reference value	
						Pm-an (%)	SNR (dB)
1	5 MHz	R.20	OP.1 FDD	EPA5	4 x 2 Medium	0.1	6.1

8.5.1.2.3 Minimum Requirement 2 Tx Antenna Port (demodulation subframe overlaps with aggressor cell ABS)

For the parameters specified in Table 8.5.1-1 and Table 8.5.1.2.3-1, the average probability of a miss-detecting ACK for NACK (P_{m-an}) shall be below the specified value in Table 8.5.1.2.3-2. The downlink physical setup is in accordance with Annex C.3.2 and Annex C.3.3. In Table 8.5.1.2.3-1, Cell 1 is the serving cell, and Cell 2 is the aggressor cell. The downlink physical channel setup for Cell 1 is according to Annex C.3.2 and for Cell 2 is according to Annex C.3.3, respectively.

Table 8.5.1.2.3-1: Test Parameters for PHICH

Parameter		Unit	Cell 1	Cell 2
Downlink power allocation	PDCCH_RA PHICH_RA OCNG_RA	dB	-3	-3
	PCFICH_RB PDCCH_RB PHICH_RB OCNG_RB	dB	-3	-3
N_{oc} at antenna port	N_{oc1}	dBm/15kHz	-100.5 (Note 1)	N/A
	N_{oc2}	dBm/15kHz	-98 (Note 2)	N/A
	N_{oc3}	dBm/15kHz	-95.3 (Note 3)	N/A
\hat{E}_s / N_{oc2}		dB	Reference Value in Table 8. 5.1.2.3-2	1.5
BW _{Channel}		MHz	10	10
Subframe Configuration			Non-MBSFN	Non-MBSFN
Time Offset between Cells		μ s	2.5 (synchronous cells)	
Cell Id			0	1
ABS pattern (Note 4)			N/A	00000100 00000100 00000100 01000100 00000100
RLM/RRM Measurement Subframe Pattern (Note 5)			00000100 00000100 00000100 00000100	N/A
CSI Subframe Sets (Note 6)	$C_{CSI,0}$		00000100 00000100 00000100 01000100 00000100	N/A
	$C_{CSI,1}$		11111011 11111011 11111011 10111011 11111011	N/A
Number of control OFDM symbols			3	3
PHICH Ng (Note 9)			1	N/A
PHICH duration			extended	N/A
Unused RE-s and PRB-s			OCNG	OCNG
Cyclic prefix			Normal	Normal
<p>Note 1: This noise is applied in OFDM symbols #1, #2, #3, #5, #6, #8, #9, #10, #12, #13 of a subframe overlapping with the aggressor ABS</p> <p>Note 2: This noise is applied in OFDM symbols #0, #4, #7, #11 of a subframe overlapping with the aggressor ABS</p> <p>Note 3: This noise is applied in OFDM symbols of a subframe overlapping with aggressor non-ABS</p> <p>Note 4: ABS pattern as defined in [9]. PHICH is transmitted in the serving cell subframe when the subframe is overlapped with the ABS subframe of aggressor cell but not in the 26th subframe indicated by the ABS pattern.</p> <p>Note 5: Time-domain measurement resource restriction pattern for PCell measurements as defined in [7]</p> <p>Note 6: As configured according to the time-domain measurement resource restriction pattern for CSI measurements defined in [7]</p> <p>Note 7: Cell 1 is the serving cell. Cell 2 is the aggressor cell. The number of the CRS ports in Cell1 and Cell2 is the same.</p> <p>Note 8: SIB-1 will not be transmitted in Cell2 in the test</p> <p>Note 9: According to Clause 6.9 in TS 36.211 [4].</p>				

Table 8.5.1.2.3-2: Minimum performance PHICH

Test Number	Reference Channel	OCNG Pattern		Propagation Conditions (Note 1)		Antenna Configuration and Correlation Matrix	Reference Value	
		Cell 1	Cell 2	Cell 1	Cell 2		Pm-an (%)	SNR (dB) (Note 2)
1	R.19	OP.1 FDD	OP.1 FDD	EPA5	EPA5	2x2 Low	0.1	4.6
Note 1: The propagation conditions for Cell 1 and Cell 2 are statistically independent.								
Note 2: SNR corresponds to \hat{E}_s/N_{oc2} of cell 1.								
Note 3: The correlation matrix and antenna configuration apply for Cell 1 and Cell 2.								

8.5.2 TDD

The parameters specified in Table 8.5.2-1 are valid for all TDD tests unless otherwise stated.

Table 8.5.2-1: Test Parameters for PHICH

Parameter	Unit	Single antenna port	Transmit diversity
Uplink downlink configuration (Note 1)		1	1
Special subframe configuration (Note 2)		4	4
Downlink power allocation	PDCCH_RA PHICH_RA OCNG_RA	dB	0
	PCFICH_RB PDCCH_RB PHICH_RB OCNG_RB	dB	0
PHICH duration		Normal	Normal
PHICH Ng (Note 3)		Ng = 1	Ng = 1
PDCCH Content		UL Grant should be included with the proper information aligned with A.3.6.	
Unused RE-s and PRB-s		OCNG	OCNG
Cell ID		0	0
N_{oc} at antenna port	dBm/15kHz	-98	-98
Cyclic prefix		Normal	Normal
ACK/NACK feedback mode		Multiplexing	Multiplexing
Note 1: as specified in Table 4.2-2 in TS 36.211 [4]			
Note 2: as specified in Table 4.2-1 in TS 36.211 [4]			
Note 3: according to Clause 6.9 in TS 36.211 [4]			

8.5.2.1 Single-antenna port performance

For the parameters specified in Table 8.5.2-1 the average probability of a miss-detecting ACK for NACK (Pm-an) shall be below the specified value in Table 8.5.2.1-1. The downlink physical setup is in accordance with Annex C.3.2.

Table 8.5.2.1-1: Minimum performance PHICH

Test number	Bandwidth	Reference Channel	OCNG Pattern	Propagation Condition	Antenna configuration and correlation Matrix	Reference value	
						Pm-an (%)	SNR (dB)
1	10 MHz	R.18	OP.1 TDD	ETU70	1 x 2 Low	0.1	5.8
2	10 MHz	R.24	OP.1 TDD	ETU70	1 x 2 Low	0.1	1.3

8.5.2.2 Transmit diversity performance

8.5.2.2.1 Minimum Requirement 2 Tx Antenna Port

For the parameters specified in Table 8.5.2-1 the average probability of a miss-detecting ACK for NACK (Pm-an) shall be below the specified value in Table 8.5.2.2.1-1. The downlink physical setup is in accordance with Annex C.3.2.

Table 8.5.2.2.1-1: Minimum performance PHICH

Test number	Bandwidth	Reference Channel	OCNG Pattern	Propagation Condition	Antenna configuration and correlation Matrix	Reference value	
						Pm-an (%)	SNR (dB)
1	10 MHz	R.19	OP.1 TDD	EVA70	2 x 2 Low	0.1	4.2

8.5.2.2.2 Minimum Requirement 4 Tx Antenna Port

For the parameters specified in Table 8.5.2-1 the average probability of a miss-detecting ACK for NACK (Pm-an) shall be below the specified value in Table 8.5.2.2.2-1. The downlink physical setup is in accordance with Annex C.3.2.

Table 8.5.2.2.2-1: Minimum performance PHICH

Test number	Bandwidth	Reference Channel	OCNG Pattern	Propagation Condition	Antenna configuration and correlation Matrix	Reference value	
						Pm-an (%)	SNR (dB)
1	5 MHz	R.20	OP.1 TDD	EPA5	4 x 2 Medium	0.1	6.2

8.5.2.2.3 Minimum Requirement 2 Tx Antenna Port (demodulation subframe overlaps with aggressor cell ABS)

For the parameters specified in Table 8.5.2-1 and Table 8.5.2.2.3-1, the average probability of a miss-detecting ACK for NACK (Pm-an) shall be below the specified value in Table 8.5.2.2.3-2. The downlink physical setup is in accordance with Annex C.3.2 and Annex C.3.3, In Table 8.5.2.2.3-1, Cell 1 is the serving cell, and Cell 2 is the aggressor cell. The downlink physical channel setup for Cell 1 is according to Annex C.3.2 and for Cell 2 is according to Annex C.3.3, respectively.

Table 8.5.2.2.3-1: Test Parameters for PHICH

Parameter		Unit	Cell 1	Cell 2
Uplink downlink configuration			1	1
Special subframe configuration			4	4
Downlink power allocation	PDCCH_RA PHICH_RA OCNG_RA	dB	-3	-3
	PCFICH_RB PDCCH_RB PHICH_RB OCNG_RB	dB	-3	-3
N_{oc} at antenna port	N_{oc1}	dBm/15kHz	-100.5 (Note 1)	N/A
	N_{oc2}	dBm/15kHz	-98 (Note 2)	N/A
	N_{oc3}	dBm/15kHz	-95.3 (Note 3)	N/A
\hat{E}_s / N_{oc2}		dB	Reference Value in Table 8.5.2.2.3-2	1.5
$BW_{Channel}$		MHz	10	10
Subframe Configuration			Non-MBSFN	Non-MBSFN
Time Offset between Cells		μ s	2.5 (synchronous cells)	
Cell Id			0	1
ABS pattern (Note 4)			N/A	0000010001 0000000001
RLM/RRM Measurement Subframe Pattern (Note 5)			0000000001 0000000001	N/A
CSI Subframe Sets (Note 6)	$C_{CSI,0}$		0000010001 0000000001	N/A
	$C_{CSI,1}$		1100101000 1100111000	N/A
Number of control OFDM symbols			3	3
ACK/NACK feedback mode			Multiplexing	N/A
PHICH N_g (Note 9)			1	N/A
PHICH duration			extended	N/A
Unused RE-s and PRB-s			OCNG	OCNG
Cyclic prefix			Normal	Normal
<p>Note 1: This noise is applied in OFDM symbols #1, #2, #3, #5, #6, #8, #9, #10, #12, #13 of a subframe overlapping with the aggressor ABS</p> <p>Note 2: This noise is applied in OFDM symbols #0, #4, #7, #11 of a subframe overlapping with the aggressor ABS</p> <p>Note 3: This noise is applied in OFDM symbols of a subframe overlapping with aggressor non-ABS</p> <p>Note 4: ABS pattern as defined in [9]. PHICH is transmitted in the serving cell subframe when the subframe is overlapped with the ABS subframe of aggressor cell but not in subframe 5</p> <p>Note 5: Time-domain measurement resource restriction pattern for PCell measurements as defined in [7]</p> <p>Note 6: As configured according to the time-domain measurement resource restriction pattern for CSI measurements defined in [7]</p> <p>Note 7: Cell 1 is the serving cell. Cell 2 is the aggressor cell. The number of the CRS ports in Cell1 and Cell2 is the same.</p> <p>Note 8: SIB-1 will not be transmitted in Cell2 in the test</p> <p>Note 9: According to Clause 6.9 in TS 36.211 [4].</p>				

Table 8.5.2.2.3-2: Minimum performance PHICH

Test Number	Reference Channel	OCNG Pattern		Propagation Conditions (Note 1)		Antenna Configuration and Correlation Matrix	Reference Value	
		Cell 1	Cell 2	Cell 1	Cell 2		Pm-an (%)	SNR (dB) (Note 2)
1	R.19	OP.1 TDD	OP.1 TDD	EPA5	EPA5	2x2 Low	0.1	4.6
Note 1: The propagation conditions for Cell 1 and Cell 2 are statistically independent.								
Note 2: SNR corresponds to \hat{E}_s/N_{oc2} of cell 1.								
Note 3: The correlation matrix and antenna configuration apply for Cell 1 and Cell 2.								

8.6 Demodulation of PBCH

The receiver characteristics of the PBCH are determined by the probability of miss-detection of the PBCH (Pm-bch).

8.6.1 FDD

Table 8.6.1-1: Test Parameters for PBCH

Parameter		Unit	Single antenna port	Transmit diversity	
Downlink power allocation	PBCH_RA	dB	0	-3	
	PBCH_RB	dB	0	-3	
N_{oc} at antenna port		dBm/15kHz	-98	-98	
Cyclic prefix			Normal	Normal	
Cell ID			0	0	
Note 1: as specified in Table 4.2-2 in TS 36.211 [4]					
Note 2: as specified in Table 4.2-1 in TS 36.211 [4]					

8.6.1.1 Single-antenna port performance

For the parameters specified in Table 8.6.1-1 the average probability of a miss-detecting PBCH (Pm-bch) shall be below the specified value in Table 8.6.1.1-1. The downlink physical setup is in accordance with Annex C.3.2.

Table 8.6.1.1-1: Minimum performance PBCH

Test number	Bandwidth	Reference Channel	Propagation Condition	Antenna configuration and correlation Matrix	Reference value	
					Pm-bch (%)	SNR (dB)
1	1.4 MHz	R.21	ETU70	1 x 2 Low	1	-6.1

8.6.1.2 Transmit diversity performance

8.6.1.2.1 Minimum Requirement 2 Tx Antenna Port

For the parameters specified in Table 8.6.1-1 the average probability of a miss-detected PBCH (Pm-bch) shall be below the specified value in Table 8.6.1.2.1-1. The downlink physical setup is in accordance with Annex C.3.2.

Table 8.6.1.2.1-1: Minimum performance PBCH

Test number	Bandwidth	Reference Channel	Propagation Condition	Antenna configuration and correlation Matrix	Reference value	
					Pm-bch (%)	SNR (dB)
1	1.4 MHz	R.22	EPA5	2 x 2 Low	1	-4.8

8.6.1.2.2 Minimum Requirement 4 Tx Antenna Port

For the parameters specified in Table 8.6.1-1 the average probability of a miss-detected PBCH (Pm-bch) shall be below the specified value in Table 8.6.1.2.2-1. The downlink physical setup is in accordance with Annex C.3.2.

Table 8.6.1.2.2-1: Minimum performance PBCH

Test number	Bandwidth	Reference Channel	Propagation Condition	Antenna configuration and correlation Matrix	Reference value	
					Pm-bch (%)	SNR (dB)
1	1.4 MHz	R.23	EVA5	4 x 2 Medium	1	-3.5

8.6.2 TDD

Table 8.6.2-1: Test Parameters for PBCH

Parameter	Unit	Single antenna port	Transmit diversity	
Uplink downlink configuration (Note 1)		1	1	
Special subframe configuration (Note 2)		4	4	
Downlink power allocation	PBCH_RA	dB	0	-3
	PBCH_RB	dB	0	-3
N_{oc} at antenna port	dBm/15kHz	-98	-98	
Cyclic prefix		Normal	Normal	
Cell ID		0	0	
Note 1: as specified in Table 4.2-2 in TS 36.211 [4].				
Note 2: as specified in Table 4.2-1 in TS 36.211 [4].				

8.6.2.1 Single-antenna port performance

For the parameters specified in Table 8.6.2-1 the average probability of a miss-detected PBCH (Pm-bch) shall be below the specified value in Table 8.6.2.1-1. The downlink physical setup is in accordance with Annex C.3.2.

Table 8.6.2.1-1: Minimum performance PBCH

Test number	Bandwidth	Reference Channel	Propagation Condition	Antenna configuration and correlation Matrix	Reference value	
					Pm-bch (%)	SNR (dB)
1	1.4 MHz	R.21	ETU70	1 x 2 Low	1	-6.4

8.6.2.2 Transmit diversity performance

8.6.2.2.1 Minimum Requirement 2 Tx Antenna Port

For the parameters specified in Table 8.6.2-1 the average probability of a miss-detected PBCH (Pm-bch) shall be below the specified value in Table 8.6.2.2.1-1. The downlink physical setup is in accordance with Annex C.3.2.

Table 8.6.2.2.1-1: Minimum performance PBCH

Test number	Bandwidth	Reference Channel	Propagation Condition	Antenna configuration and correlation Matrix	Reference value	
					Pm-bch (%)	SNR (dB)
1	1.4 MHz	R.22	EPA5	2 x 2 Low	1	-4.8

8.6.2.2.2 Minimum Requirement 4 Tx Antenna Port

For the parameters specified in Table 8.6.2-1 the average probability of a miss-detected PBCH (Pm-bch) shall be below the specified value in Table 8.6.2.2.2-1. The downlink physical setup is in accordance with Annex C.3.2.

Table 8.6.2.2.2-1: Minimum performance PBCH

Test number	Bandwidth	Reference Channel	Propagation Condition	Antenna configuration and correlation Matrix	Reference value	
					Pm-bch (%)	SNR (dB)
1	1.4 MHz	R.23	EVA5	4 x 2 Medium	1	-4.1

8.7 Sustained downlink data rate provided by lower layers

The purpose of the test is to verify that the Layer 1 and Layer 2 correctly process in a sustained manner the received packets corresponding to the maximum number of DL-SCH transport block bits received within a TTI for the UE category indicated. The sustained downlink data rate shall be verified in terms of the success rate of delivered PDCP SDU(s) by Layer 2. The test case below specifies the RF conditions and the required success rate of delivered TB by Layer 1 to meet the sustained data rate requirement. The size of the TB per TTI corresponds to the largest possible DL-SCH transport block for each UE category using the maximum number of layers for spatial multiplexing. Transmission modes 1 and 3 are used with radio conditions resembling a scenario where sustained maximum data rates are available.

8.7.1 FDD

The parameters specified in Table 8.7.1-1 are valid for all FDD tests unless otherwise stated.

Table 8.7.1-1: Common Test Parameters (FDD)

Parameter	Unit	Value
Cyclic prefix		Normal
Cell ID		0
Inter-TTI Distance		1
Number of HARQ processes per component carrier	Processes	8
Maximum number of HARQ transmission		4
Redundancy version coding sequence		{0,0,1,2} for 64QAM
Number of OFDM symbols for PDCCH per component carrier	OFDM symbols	1
Cross carrier scheduling		Not configured

The requirements are specified in Table 8.7.1-3, with the addition of the parameters in Table 8.7.1-2 and the downlink physical channel setup according to Annex C.3.2. The test points are applied to UE category, CA capability and bandwidth combination with maximum aggregated bandwidth as specified in Table 8.7.1-4. The TB success rate shall be sustained during at least 300 frames.

The test coverage for different number of component carriers is defined in 8.1.2.4.

Table 8.7.1-2: test parameters for sustained downlink data rate (FDD)

Parameter	Unit	Test 1	Test 2	Test 3,4,6	Test 3A	Test 3B	Test 4A	Test 3C, 4B	Test 6A
Bandwidth	MHz	10	10	20	10	2x10	2x10	15	2x20
Transmission mode		1	3	3	3	3	3	3	3
Antenna configuration		1 x 2	2 x 2	2 x 2	2 x 2	2x2	2x2	2 x 2	2 x 2
Propagation condition		Static propagation condition (Note 1)							
CodeBookSubsetRestriction bitmap		n/a	10	10	10	10	10	10	10
Downlink power allocation	ρ_A	dB	0	-3	-3	-3	-3	-3	-3
	ρ_B	dB	0	-3	-3	-3	-3	-3	-3
	σ	dB	0	0	0	0	0	0	0
\hat{E}_s at antenna port	dBm/15kHz	-85	-85	-85	-85	-85	-85	-85	-85
Symbols for unused PRBs		OP.6 FDD	OP.1 FDD	OP.1 FDD	OP.1 FDD	OP.1 FDD	OP.1 FDD	OP.1 FDD	OP.1 FDD
Note 1: No external noise sources are applied.									
Note 2: For CA test cases, PUCCH format 1b with channel selection is used to feedback ACK/NACK.									

Table 8.7.1-3: Minimum requirement (FDD)

Test	Number of bits of a DL-SCH transport block received within a TTI	Measurement channel	Reference value
			TB success rate [%]
1	10296	R.31-1 FDD	95
2	25456	R.31-2 FDD	95
3	51024	R.31-3 FDD	95
3A	36696 (Note 2)	R.31-3A FDD	85
3B	25456	R.31-2 FDD	95
3C	51024	R.31-3C	85
4	75376 (Note 3)	R.31-4 FDD	85
4A	36696 (Note 2)	R.31-3A FDD	85
4B	55056 (Note 5)	R.31-4B FDD	85
6	75376 (Note 3)	R.31-4 FDD	85
6A	75376 (Note 3)	R.31-4 FDD	85
Note 1: For 2 layer transmissions, 2 transport blocks are received within a TTI. Note 2: 35160 bits for sub-frame 5. Note 3: 71112 bits for sub-frame 5. Note 4: The TB success rate is defined as TB success rate = $100\% \cdot N_{DL_correct_rx} / (N_{DL_newtx} + N_{DL_retx})$, where N_{DL_newtx} is the number of newly transmitted DL transport blocks, N_{DL_retx} is the number of retransmitted DL transport blocks, and $N_{DL_correct_rx}$ is the number of correctly received DL transport blocks. Note 5: 52752bits for sub-frame 5.			

Table 8.7.1-4: Test points for sustained data rate (FRC)

CA config	Maximum supported Bandwidth/ Bandwidth combination (MHz)	Category 1	Category 2	Category 3	Category 4	Category 6	Category 7
Single carrier	10	1	2	3A	3A	-	-
	15	-	-	3C	4B	-	-
	20	-	-	3	4	6	6
CA with 2CCs	10+10	-	-	3B	4A	6A	6A
	20+20	-	-	3 (Note 4)	4 (Note 4)	6A	6A
Note 1: Void. Note 2: For non-CA UE, test is selected for maximum supported bandwidth. Note 3: Void. Note 4: If the intra-band contiguous CA is the only CA configuration supported by category 3 or 4 UE, the single carrier test is selected, i.e., Test 3 for UE category 3 and Test 4 for UE category 4. Note 5: The applicability of requirements for different CA configurations and bandwidth combination sets is defined in 8.1.2.3.							

8.7.2 TDD

The parameters specified in Table 8.7.2-1 are valid for all TDD tests unless otherwise stated.

Table 8.7.2-1: Common Test Parameters (TDD)

Parameter	Unit	Value
Special subframe configuration (Note 1)		4
Cyclic prefix		Normal
Cell ID		0
Inter-TTI Distance		1
Maximum number of HARQ transmission		4
Redundancy version coding sequence		{0,0,1,2} for 64QAM
Number of OFDM symbols for PDCCH per component carrier	OFDM symbols	1
Cross carrier scheduling		Not configured
Note 1: as specified in Table 4.2-1 in TS 36.211 [4].		

The requirements are specified in Table 8.7.2-3, with the addition of the parameters in Table 8.7.2-2 and the downlink physical channel setup according to Annex C.3.2. The test points are applied to UE category, CA capability and bandwidth combination with maximum aggregated bandwidth as specified in Table 8.7.2-4. The TB success rate shall be sustained during at least 300 frames.

The test coverage for different number of component carriers is defined in 8.1.2.4.

Table 8.7.2-2: test parameters for sustained downlink data rate (TDD)

Parameter	Unit	Test 1	Test 2	Test 3	Test 3A	Test 4,6	Test 6A
Bandwidth	MHz	10	10	20	15	20	2x20
Transmission mode		1	3	3	3	3	3
Antenna configuration		1 x 2	2 x 2	2 x 2	2 x 2	2 x 2	2 x 2
Propagation condition		Static propagation condition (Note 1)					
CodeBookSubsetRestriction bitmap		n/a	10	10	10	10	10
Downlink power allocation	ρ_A	dB	0	-3	-3	-3	-3
	ρ_B	dB	0	-3	-3	-3	-3
	σ	dB	0	0	0	0	0
\hat{E}_s at antenna port	dBm/15kHz	-85	-85	-85	-85	-85	-85
Symbols for unused PRBs		OP.6 TDD	OP.1 TDD	OP.1 TDD	OP.2 TDD	OP.1 TDD	OP.1 TDD
ACK/NACK feedback mode		Bundling	Bundling	Bundling	Multiplexing	Multiplexing	- (Note 2)
Note 1: No external noise sources are applied.							
Note 2: PUCCH format 1b with channel selection is used to feedback ACK/NACK.							

Table 8.7.2-3: Minimum requirement (TDD)

Test	Number of bits of a DL-SCH transport block received within a TTI for normal/special sub-frame	Measurement channel	Reference value
			TB success rate [%]
1	10296/0	R31-1 TDD	95
2	25456/0	R31-2 TDD	95
3	51024/0	R31-3 TDD	95
3A	51024/0	R31-3A TDD	85
4	75376/0 (Note 2)	R31-4 TDD	85
6	75376/0 (Note 2)	R.31-4 TDD	85
6A	75376/0 (Note 2)	R.31-4 TDD	85
Note 1:	For 2 layer transmissions, 2 transport blocks are received within a TTI.		
Note 2:	71112 bits for sub-frame 5.		
Note 3:	The TB success rate is defined as TB success rate = $100\% \cdot N_{DL_correct_rx} / (N_{DL_newtx} + N_{DL_retx})$, where N_{DL_newtx} is the number of newly transmitted DL transport blocks, N_{DL_retx} is the number of retransmitted DL transport blocks, and $N_{DL_correct_rx}$ is the number of correctly received DL transport blocks.		

Table 8.7.2-4: Test points for sustained data rate (FRC)

CA config	Maximum supported Bandwidth/ Bandwidth combination (MHz)	Category 1	Category 2	Category 3	Category 4	Category 6	Category 7
Single carrier	10	1	2	-	-	-	-
	15	-	-	3A	3A	-	-
	20	-	-	3	4	6	6
CA with 2CCs	20+20	-	--	3 (Note 4)	4 (Note 4)	6A	6A
Note 1:	Void.						
Note 2:	For non-CA UE, test is selected for maximum supported bandwidth.						
Note 3:	Void.						
Note 4:	If the intra-band contiguous CA is the only CA configuration supported by category 3 or 4 UE, single carrier test is selected.						
Note 5:	The applicability of requirements for different CA configurations and bandwidth combination sets is defined in 8.1.2.3.						

9 Reporting of Channel State Information

9.1 General

This section includes requirements for the reporting of channel state information (CSI). For all test cases in this section,

the definition of SNR is in accordance with the one given in clause 8.1.1, where $SNR = \frac{\sum \hat{I}_{or}^{(j)}}{\sum N_{oc}^{(j)}}$

9.1.1 Applicability of requirements

9.1.1.1 Applicability of requirements for different channel bandwidths

In Clause 9 the test cases may be defined with different channel bandwidth to verify the same CSI requirement.

9.1.1.2 Applicability and test rules for different CA configurations and bandwidth combination sets

The performance requirement for CA CQI tests in Clause 9 are defined independent of CA configurations and bandwidth combination sets specified in Clause 5.6A.1. For UEs supporting different CA configurations and bandwidth combination sets, the applicability and test rules are defined for the tests for 2 DL CCs in Table 9.1.1.2-1. For simplicity, CA configuration below refers to combination of CA configuration and bandwidth combination set. The definition of CA capability is specified in 8.1.2.2.

Table 9.1.1.2-1: Applicability and test rules for CA UE CQI tests with 2 DL CCs

Tests	CA capability where the tests apply	CA configuration from the selected CA capability where the tests apply	CA Bandwidth combination to be tested in priority order
CA tests with 2CCs in Clause 9.6.1.1	Any of one of the supported CA capabilities	Any one of the supported FDD CA configurations	10+10 MHz, 20+20 MHz
CA tests with 2CCs in Clause 9.6.1.2	Any of one of the supported CA capabilities with largest aggregated CA bandwidth combination	Any one of the supported TDD CA configurations with largest aggregated CA bandwidth combination	Largest aggregated CA bandwidth combination
Note 1: The applicability and test rules are specified in this table, unless otherwise stated. Note 2: Number of the supported bandwidth combinations to be tested from each selected CA configuration is one.			

9.2 CQI reporting definition under AWGN conditions

The reporting accuracy of the channel quality indicator (CQI) under frequency non-selective conditions is determined by the reporting variance and the BLER performance using the transport format indicated by the reported CQI median. The purpose is to verify that the reported CQI values are in accordance with the CQI definition given in TS 36.213 [6]. To account for sensitivity of the input SNR the reporting definition is considered to be verified if the reporting accuracy is met for at least one of two SNR levels separated by an offset of 1 dB.

9.2.1 Minimum requirement PUCCH 1-0 (Cell-Specific Reference Symbols)

9.2.1.1 FDD

The following requirements apply to UE Category 1-8. For the parameters specified in Table 9.2.1.1-1, and using the downlink physical channels specified in tables C.3.2-1 and C.3.2-2, the reported CQI value according to RC.1 FDD in Table A.4-1 shall be in the range of ± 1 of the reported median more than 90% of the time. If the PDSCH BLER using the transport format indicated by median CQI is less than or equal to 0.1, the BLER using the transport format indicated by the (median CQI + 1) shall be greater than 0.1. If the PDSCH BLER using the transport format indicated by the median CQI is greater than 0.1, the BLER using transport format indicated by (median CQI – 1) shall be less than or equal to 0.1.

Table 9.2.1.1-1: PUCCH 1-0 static test (FDD)

Parameter		Unit	Test 1		Test 2	
Bandwidth		MHz	10			
PDSCH transmission mode			1			
Downlink power allocation	ρ_A	dB	0			
	ρ_B	dB	0			
	σ	dB	0			
Propagation condition and antenna configuration			AWGN (1 x 2)			
SNR (Note 2)		dB	0	1	6	7
$\hat{I}_{or}^{(j)}$		dB[mW/15kHz]	-98	-97	-92	-91
$N_{oc}^{(j)}$		dB[mW/15kHz]	-98		-98	
Max number of HARQ transmissions			1			
Physical channel for CQI reporting			PUCCH Format 2			
PUCCH Report Type			4			
Reporting periodicity		ms	$N_{pd} = 5$			
<i>cqi-pmi-ConfigurationIndex</i>			6			
Note 1: Reference measurement channel according RC.1 FDD to Table A.4-1 with one sided dynamic OCNG Pattern OP.1 FDD as described in Annex A.5.1.1, except for category 1 UE use RC.4 FDD with two sided dynamic OCNG Pattern OP.2 FDD as described in Annex A.5.1.2. Note 2: For each test, the minimum requirements shall be fulfilled for at least one of the two SNR(s) and the respective wanted signal input level.						

9.2.1.2 TDD

The following requirements apply to UE Category 1-8. For the parameters specified in Table 9.2.1.2-1, and using the downlink physical channels specified in tables C.3.2-1 and C.3.2-2, the reported CQI value according to RC.1 TDD in Table A.4-1 shall be in the range of ± 1 of the reported median more than 90% of the time. If the PDSCH BLER using the transport format indicated by median CQI is less than or equal to 0.1, the BLER using the transport format indicated by the (median CQI + 1) shall be greater than 0.1. If the PDSCH BLER using the transport format indicated by the median CQI is greater than 0.1, the BLER using transport format indicated by (median CQI – 1) shall be less than or equal to 0.1.

Table 9.2.1.2-1: PUCCH 1-0 static test (TDD)

Parameter		Unit	Test 1		Test 2	
Bandwidth		MHz			10	
PDSCH transmission mode					1	
Uplink downlink configuration					2	
Special subframe configuration					4	
Downlink power allocation	ρ_A	dB			0	
	ρ_B	dB			0	
	σ	dB			0	
Propagation condition and antenna configuration			AWGN (1 x 2)			
SNR (Note 2)		dB	0	1	6	7
$\hat{I}_{or}^{(j)}$		dB[mW/15kHz]	-98	-97	-92	-91
$N_{oc}^{(j)}$		dB[mW/15kHz]	-98		-98	
Max number of HARQ transmissions			1			
Physical channel for CQI reporting			PUSCH (Note 3)			
PUCCH Report Type			4			
Reporting periodicity		ms	$N_{pd} = 5$			
<i>cqi-pmi-ConfigurationIndex</i>			3			
ACK/NACK feedback mode			Multiplexing			
Note 1:		Reference measurement channel RC.1 TDD according to Table A.4-1 with one sided dynamic OCNG Pattern OP.1 TDD as described in Annex A.5.2.1, except for category 1 UE use RC.4 TDD with two sided dynamic OCNG Pattern OP.2 TDD as described in Annex A.5.2.2.				
Note 2:		For each test, the minimum requirements shall be fulfilled for at least one of the two SNR(s) and the respective wanted signal input level.				
Note 3:		To avoid collisions between CQI reports and HARQ-ACK it is necessary to report both on PUSCH instead of PUCCH. PDCCH DCI format 0 shall be transmitted in downlink SF#3 and #8 to allow periodic CQI to multiplex with the HARQ-ACK on PUSCH in uplink subframe SF#7 and #2.				

9.2.1.3 FDD (CSI measurements in case two CSI subframe sets are configured)

The following requirements apply to UE Category 1-8. For the parameters specified in Table 9.2.1.3-1, and using the downlink physical channels specified in tables C.3.2-1 for Cell 1, C.3.3-1 for Cell 2 and C.3.2-2, the reported CQI value according to RC.2 FDD / RC.6 FDD in Table A.4-1 in subframes overlapping with aggressor cell ABS and non-ABS subframes shall be in the range of ± 1 of the reported median more than 90% of the time. If the PDSCH BLER in non-ABS subframes using the transport format indicated by median CQI obtained by reports in CSI subframe sets $C_{CSI,1}$ is less than or equal to 0.1, the BLER in non-ABS subframes using the transport format indicated by the (median CQI + 1) shall be greater than 0.1. If the PDSCH BLER in non-ABS subframes using the transport format indicated by the median CQI is greater than 0.1, the BLER in non-ABS subframes using transport format indicated by (median CQI – 1) shall be less than or equal to 0.1. The value of the median CQI obtained by reports in CSI subframe sets $C_{CSI,0}$ minus the median CQI obtained by reports in CSI subframe sets $C_{CSI,1}$ shall be larger than or equal to 2 and less than or equal to 5 in Test 1 and shall be larger than or equal to 0 and less than or equal to 1 in Test 2.

Table 9.2.1.3-1: PUCCH 1-0 static test (FDD)

Parameter		Unit	Test 1			Test 2		
			Cell 1	Cell 2		Cell 1	Cell 2	
Bandwidth		MHz	10			10		
PDSCH transmission mode			2	Note 10		2	Note 10	
Downlink power allocation	ρ_A	dB	-3			-3		
	ρ_B	dB	-3			-3		
	σ	dB	0			0		
Propagation condition and antenna configuration			Clause B.1 (2x2)			Clause B.1 (2x2)		
\hat{E}_s/N_{oc2} (Note 1)		dB	4	5	6	4	5	-12
$N_{oc}^{(j)}$ at antenna port	$N_{oc1}^{(j)}$	dBm/15kHz	-102 (Note 7)		N/A	-98(Note 7)		N/A
	$N_{oc2}^{(j)}$	dBm/15kHz	-98 (Note 8)		N/A	-98(Note 8)		N/A
	$N_{oc3}^{(j)}$	dBm/15kHz	-94.8 (Note 9)		N/A	-98(Note 9)		N/A
$\hat{I}_{or}^{(j)}$		dB[mW/15kHz]	-94	-93	-92	-94	-93	-110
Subframe Configuration			Non-MBSFN		Non-MBSFN	Non-MBSFN		Non-MBSFN
Cell Id			0		1	0		1
Time Offset between Cells		μ s	2.5 (synchronous cells)			2.5 (synchronous cells)		
ABS pattern (Note 2)			N/A		01010101 01010101 01010101 01010101 01010101	N/A		01010101 01010101 01010101 01010101 01010101
RLM/RRM Measurement Subframe Pattern (Note 4)			00000100 00000100 00000100 00000100 00000100		N/A	00000100 00000100 00000100 00000100 00000100		N/A
CSI Subframe Sets (Note 3)	$C_{CSI,0}$		01010101 01010101 01010101 01010101 01010101		N/A	01010101 01010101 01010101 01010101 01010101		N/A
	$C_{CSI,1}$		10101010 10101010 10101010 10101010 10101010		N/A	10101010 10101010 10101010 10101010 10101010		N/A
Number of control OFDM symbols			3			3		
Max number of HARQ transmissions			1			1		
Physical channel for $C_{CSI,0}$ CQI reporting			PUCCH Format 2			PUCCH Format 2		
Physical channel for $C_{CSI,1}$ CQI reporting			PUSCH (Note 12)			PUSCH (Note 12)		
PUCCH Report Type			4			4		
Reporting periodicity		Ms	$N_{pd} = 5$			$N_{pd} = 5$		
$cqi-pmi-ConfigurationIndex_{C_{CSI,0}}$ (Note 13)			6	N/A		6	N/A	
$cqi-pmi-ConfigurationIndex2_{C_{CSI,1}}$ (Note 14)			5	N/A		5	N/A	

Note 1:	For each test, the minimum requirements shall be fulfilled for at least one of the two SNR(s) and the respective wanted signal input level.
Note 2:	ABS pattern as defined in [9].
Note 3:	Time-domain measurement resource restriction pattern for PCell measurements as defined in [7]
Note 4:	As configured according to the time-domain measurement resource restriction pattern for CSI measurements defined in [7]
Note 5:	Time-domain measurement resource restriction pattern for PCell measurements as defined in [7]
Note 6:	Cell 1 is the serving cell. Cell 2 is the aggressor cell. The number of the CRS ports in Cell1 and Cell2 is the same.
Note 7:	This noise is applied in OFDM symbols #1, #2, #3, #5, #6, #8, #9, #10,#12, #13 of a subframe overlapping with the aggressor ABS.
Note 8:	This noise is applied in OFDM symbols #0, #4, #7, #11 of a subframe overlapping with the aggressor ABS.
Note 9:	This noise is applied in all OFDM symbols of a subframe overlapping with aggressor non-ABS.
Note 10:	Downlink physical channel setup in Cell 2 in accordance with Annex C.3.3 applying OCNG pattern as defined in Annex A.5.1.5
Note 11:	Reference measurement channel in Cell 1 RC.2 FDD according to Table A.4-1 for UE Category 2-8 with one sided dynamic OCNG Pattern OP.1 FDD as described in Annex A.5.1.1, and RC.6 FDD according to Table A.4-1 for Category 1 with one/two sided dynamic OCNG Pattern OP. 1/2 FDD as described in Annex A.5.1.1 and A.5.1.2.
Note 12:	To avoid collisions between HARQ-ACK and wideband CQI it is necessary to report both on PUSCH instead of PUCCH. PDCCH DCI format 0 shall be transmitted in downlink SF#4 and #9 to allow periodic CQI to multiplex with the HARQ-ACK on PUSCH in uplink subframe SF#8 and #3.
Note 13:	<i>cqi-pmi-ConfigurationIndex</i> is applied for $C_{CSI,0}$.
Note 14:	<i>cqi-pmi-ConfigurationIndex2</i> is applied for $C_{CSI,1}$.

9.2.1.4 TDD (CSI measurements in case two CSI subframe sets are configured)

The following requirements apply to UE Category 1-8. For the parameters specified in Table 9.2.1.4-1, and using the downlink physical channels specified in tables C.3.2-1 for Cell 1, C.3.3-1 for Cell 2 and C.3.2-2, the reported CQI value according to RC.2 TDD / RC.6 TDD in Table A.4-1 in subframes overlapping with aggressor cell ABS and non-ABS subframes shall be in the range of ± 1 of the reported median more than 90% of the time. If the PDSCH BLER in non-ABS subframes using the transport format indicated by median CQI obtained by reports in CSI subframe sets $C_{CSI,1}$ is less than or equal to 0.1, the BLER in non-ABS subframes using the transport format indicated by the (median CQI + 1) shall be greater than 0.1. If the PDSCH BLER in non-ABS subframes using the transport format indicated by the median CQI is greater than 0.1, the BLER in non-ABS subframes using transport format indicated by (median CQI – 1) shall be less than or equal to 0.1. The value of the median CQI obtained by reports in CSI subframe sets $C_{CSI,0}$ minus the median CQI obtained by reports in CSI subframe sets $C_{CSI,1}$ shall be larger than or equal to 2 and less than or equal to 5 in Test 1 and shall be larger than or equal to 0 and less than or equal to 1 in Test 2.

Table 9.2.1.4-1: PUCCH 1-0 static test (TDD)

Parameter	Unit	Test 1			Test 2			
		Cell 1		Cell 2	Cell 1		Cell 2	
Bandwidth	MHz	10			10			
PDSCH transmission mode		2		Note 10	2		Note 10	
Uplink downlink configuration		1			1			
Special subframe configuration		4			4			
Downlink power allocation	ρ_A	dB			-3			
	ρ_B	dB			-3			
	σ	dB			0			
Propagation condition and antenna configuration		Clause B.1 (2x2)			Clause B.1 (2x2)			
\hat{E}_s / N_{oc2} (Note 1)	dB	4	5	6	4	5	-12	
$N_{oc}^{(j)}$ at antenna port	$N_{oc1}^{(j)}$	dBm/15kHz		-102(Note 7)	N/A		-98(Note 7)	N/A
	$N_{oc2}^{(j)}$	dBm/15kHz		-98(Note 8)	N/A		-98(Note 8)	N/A
	$N_{oc3}^{(j)}$	dBm/15kHz		-94.8(Note 9)	N/A		-98(Note 9)	N/A
$\hat{I}_{or}^{(j)}$	dB[mW/15kHz]	-94	-93	-92	-94	-93	-110	
Subframe Configuration		Non-MBSFN		Non-MBSFN	Non-MBSFN		Non-MBSFN	
Cell Id		0		1	0		1	
Time Offset between Cells	μ s	2.5 (synchronous cells)			2.5 (synchronous cells)			
ABS pattern (Note 2)		N/A		0100010001 0100010001	N/A		0100010001 0100010001	
RLM/RRM Measurement Subframe Pattern (Note 4)		0000000001 0000000001		N/A	0000000001 0000000001		N/A	
CSI Subframe Sets (Note 3)	$C_{CSI,0}$	0100010001 0100010001		N/A	0100010001 0100010001		N/A	
	$C_{CSI,1}$	1000101000 1000101000		N/A	1000101000 1000101000		N/A	
Number of control OFDM symbols		3			3			
Max number of HARQ transmissions		1			1			
Physical channel for $C_{CSI,0}$ CQI reporting		PUCCH Format 2			PUCCH Format 2			
Physical channel for $C_{CSI,1}$ CQI reporting		PUSCH (Note 12)			PUSCH (Note 12)			
PUCCH Report Type		4			4			
Reporting periodicity	ms	$N_{pd} = 5$			$N_{pd} = 5$			
<i>cqi-pmi-ConfigurationIndex</i> $C_{CSI,0}$ (Note 13)		3		N/A	3		N/A	
<i>cqi-pmi-ConfigurationIndex2</i> $C_{CSI,1}$ (Note 14)		4		N/A	4		N/A	
ACK/NACK feedback mode		Multiplexing			Multiplexing			

Note 1:	For each test, the minimum requirements shall be fulfilled for at least one of the two SNR(s) and the respective wanted signal input level.
Note 2:	ABS pattern as defined in [9].
Note 3:	Time-domain measurement resource restriction pattern for PCell measurements as defined in [7]
Note 4:	As configured according to the time-domain measurement resource restriction pattern for CSI measurements defined in [7].
Note 5:	Time-domain measurement resource restriction pattern for PCell measurements as defined in [7]
Note 6:	Cell 1 is the serving cell. Cell 2 is the aggressor cell. The number of the CRS ports in Cell1 and Cell2 is the same.
Note 7:	This noise is applied in OFDM symbols #1, #2, #3, #5, #6, #8, #9, #10,#12, #13 of a subframe overlapping with the aggressor ABS.
Note 8:	This noise is applied in OFDM symbols #0, #4, #7, #11 of a subframe overlapping with the aggressor ABS
Note 9:	This noise is applied in all OFDM symbols of a subframe overlapping with aggressor non-ABS.
Note 10:	Downlink physical channel setup in Cell 2 in accordance with Annex C.3.3 applying OCNG pattern as defined in Annex A.5.2.5
Note 11:	Reference measurement channel in Cell 1 RC.2 TDD according to Table A.4-1 for UE Category 2-8 with one sided dynamic OCNG Pattern OP.1 TDD as described in Annex A.5.2.1, and RC.6 TDD according to Table A.4-1 for Category 1 with one/two sided dynami OCNG Pattern OP.1/2 TDD as described in Annex A.5.2.1 and Annex A.5.2.2.
Note 12:	To avoid collisions between HARQ-ACK and wideband CQI it is necessary to report both on PUSCH instead of PUCCH. PDCCH DCI format 0 shall be transmitted in downlink SF#4 and #9 to allow periodic CQI to multiplex with the HARQ-ACK on PUSCH in uplink subframe SF#8 and #3.
Note 13:	<i>cqi-pmi-ConfigurationIndex</i> is applied for $C_{CSI,0}$.
Note 14:	<i>cqi-pmi-ConfigurationIndex2</i> is applied for $C_{CSI,1}$.

9.2.2 Minimum requirement PUCCH 1-1 (Cell-Specific Reference Symbols)

The minimum requirements for dual codeword transmission are defined in terms of a reporting spread of the wideband CQI value for codeword #1, and their BLER performance using the transport format indicated by the reported CQI median of codeword #0 and codeword #1. The precoding used at the transmitter is a fixed precoding matrix specified by the bitmap parameter *codebookSubsetRestriction*. The propagation condition assumed for the minimum performance requirement is defined in subclause B.1.

9.2.2.1 FDD

The following requirements apply to UE Category 2-8. For the parameters specified in table 9.2.2.1-1, and using the downlink physical channels specified in tables C.3.2-1 and C.3.2-2, the reported offset level of the wideband spatial differential CQI for codeword #1 (Table 7.2-2 in TS 36.213 [6]) shall be used to determine the wideband CQI index for codeword #1 as

$$\text{wideband CQI}_1 = \text{wideband CQI}_0 - \text{Codeword 1 offset level}$$

The wideband CQI_1 shall be within the set $\{\text{median CQI}_1 - 1, \text{median CQI}_1, \text{median CQI}_1 + 1\}$ for more than 90% of the time, where the resulting wideband values CQI_1 shall be used to determine the median CQI values for codeword #1. For both codewords #0 and #1, the PDSCH BLER using the transport format indicated by the respective median $\text{CQI}_0 - 1$ and median $\text{CQI}_1 - 1$ shall be less than or equal to 0.1. Furthermore, for both codewords #0 and #1, the PDSCH BLER using the transport format indicated by the respective median $\text{CQI}_0 + 1$ and median $\text{CQI}_1 + 1$ shall be greater than or equal to 0.1.

Table 9.2.2.1-1: PUCCH 1-1 static test (FDD)

Parameter		Unit	Test 1		Test 2	
Bandwidth		MHz	10			
PDSCH transmission mode			4			
Downlink power allocation	ρ_A	dB	-3			
	ρ_B	dB	-3			
	σ	dB	0			
Propagation condition and antenna configuration			Clause B.1 (2 x 2)			
CodeBookSubsetRestriction bitmap			010000			
SNR (Note 2)		dB	10	11	16	17
$\hat{I}_{or}^{(j)}$		dB[mW/15kHz]	-88	-87	-82	-81
$N_{oc}^{(j)}$		dB[mW/15kHz]	-98		-98	
Max number of HARQ transmissions			1			
Physical channel for CQI/PMI reporting			PUCCH Format 2			
PUCCH Report Type for CQI/PMI			2			
PUCCH Report Type for RI			3			
Reporting periodicity		ms	$N_{pd} = 5$			
<i>cqi-pmi-ConfigurationIndex</i>			6			
<i>ri-ConfigIndex</i>			1 (Note 3)			
<p>Note 1: Reference measurement channel RC.2 FDD according to Table A.4-1 with one sided dynamic OCNG Pattern OP.1 FDD as described in Annex A.5.1.1.</p> <p>Note 2: For each test, the minimum requirements shall be fulfilled for at least one of the two SNR(s) and the respective wanted signal input level.</p> <p>Note 3: It is intended to have UL collisions between RI reports and HARQ-ACK, since the RI reports shall not be used by the eNB in this test.</p>						

9.2.2.2 TDD

The following requirements apply to UE Category 2-8. For the parameters specified in table 9.2.2.2-1, and using the downlink physical channels specified in tables C.3.2-1 and C.3.2-2, the reported offset level of the wideband spatial differential CQI for codeword #1 (Table 7.2-2 in TS 36.213 [6]) shall be used to determine the wideband CQI index for codeword #1 as

$$\text{wideband CQI}_1 = \text{wideband CQI}_0 - \text{Co RC.2 TDD deward 1 offset level}$$

The wideband CQI_1 shall be within the set $\{\text{median CQI}_1 - 1, \text{median CQI}_1, \text{median CQI}_1 + 1\}$ for more than 90% of the time, where the resulting wideband values CQI_1 shall be used to determine the median CQI values for codeword #1. For both codewords #0 and #1, the PDSCH BLER using the transport format indicated by the respective median $\text{CQI}_0 - 1$ and median $\text{CQI}_1 - 1$ shall be less than or equal to 0.1. Furthermore, for both codewords #0 and #1, the PDSCH BLER using the transport format indicated by the respective median $\text{CQI}_0 + 1$ and median $\text{CQI}_1 + 1$ shall be greater than or equal to 0.1.

Table 9.2.2.2-1: PUCCH 1-1 static test (TDD)

Parameter		Unit	Test 1		Test 2	
Bandwidth		MHz			10	
PDSCH transmission mode					4	
Uplink downlink configuration					2	
Special subframe configuration					4	
Downlink power allocation	ρ_A	dB			-3	
	ρ_B	dB			-3	
	σ	dB			0	
Propagation condition and antenna configuration			Clause B.1 (2 x 2)			
CodeBookSubsetRestriction bitmap			010000			
SNR (Note 2)		dB	10	11	16	17
$\hat{I}_{or}^{(j)}$		dB[mW/15kHz]	-88	-87	-82	-81
$N_{oc}^{(j)}$		dB[mW/15kHz]	-98		-98	
Max number of HARQ transmissions			1			
Physical channel for CQI/PMI reporting			PUSCH (Note 3)			
PUCCH Report Type			2			
Reporting periodicity		ms	$N_{pd} = 5$			
<i>cqi-pmi-ConfigurationIndex</i>			3			
<i>ri-ConfigIndex</i>			805 (Note 4)			
ACK/NACK feedback mode			Multiplexing			
Note 1:		Reference measurement channel RC.2 TDD according to Table A.4-1 with one sided dynamic OCNG Pattern OP.1 TDD as described in Annex A.5.2.1.				
Note 2:		For each test, the minimum requirements shall be fulfilled for at least one of the two SNR(s) and the respective wanted signal input level.				
Note 3:		To avoid collisions between CQI/PMI reports and HARQ-ACK it is necessary to report both on PUSCH instead of PUCCH. PDCCH DCI format 0 shall be transmitted in downlink SF#3 and #8 to allow periodic CQI/PMI to multiplex with the HARQ-ACK on PUSCH in uplink subframe SF#7 and #2.				
Note 4:		RI reporting interval is set to the maximum allowable length of 160ms to minimise collisions between RI, CQI/PMI and HARQ-ACK reports. In the case when all three reports collide, it is expected that CQI/PMI reports will be dropped, while RI and HARQ-ACK will be multiplexed. At eNB, CQI report collection shall be skipped every 160ms during performance verification.				

9.2.3 Minimum requirement PUCCH 1-1 (CSI Reference Symbols)

The minimum requirements for dual codeword transmission are defined in terms of a reporting spread of the wideband CQI value for codeword #1, and their BLER performance using the transport format indicated by the reported CQI median of codeword #0 and codeword #1. The precoding used at the transmitter is a fixed precoding matrix specified by the bitmap parameter *codebookSubsetRestriction*. The propagation condition assumed for the minimum performance requirement is defined in subclause B.1.

9.2.3.1 FDD

The following requirements apply to UE Category 2-8. For the parameters specified in table 9.2.3.1-1, and using the downlink physical channels specified in tables C.3.2-1 and C.3.2-2, the reported offset level of the wideband spatial differential CQI for codeword #1 (Table 7.2-2 in TS 36.213 [6]) shall be used to determine the wideband CQI index for codeword #1 as

$$\text{wideband CQI}_1 = \text{wideband CQI}_0 - \text{Codeword 1 offset level}$$

The wideband CQI₁ shall be within the set {median CQI₁ - 1, median CQI₁, median CQI₁ + 1} for more than 90% of the time, where the resulting wideband values CQI₁ shall be used to determine the median CQI values for codeword #1. For both codewords #0 and #1, the PDSCH BLER using the transport format indicated by the respective median CQI₀ - 1 and median CQI₁ - 1 shall be less than or equal to 0.1. Furthermore, for both codewords #0 and #1, the PDSCH BLER

using the transport format indicated by the respective median $CQI_0 + 1$ and median $CQI_1 + 1$ shall be greater than or equal to 0.1.

Table 9.2.3.1-1: PUCCH 1-1 static test (FDD)

Parameter		Unit	Test 1		Test 2	
Bandwidth		MHz	10			
PDSCH transmission mode			9			
Downlink power allocation	ρ_A	dB	0			
	ρ_B	dB	0			
	P_c	dB	-3			
	σ	dB	-3			
Cell-specific reference signals			Antenna ports 0, 1			
CSI reference signals			Antenna ports 15,...,18			
Beamforming model			As specified in Section B.4.3			
CSI-RS periodicity and subframe offset $T_{CSI-RS} / \Delta_{CSI-RS}$			5/1			
CSI reference signal configuration			0			
Propagation condition and antenna configuration			Clause B.1 (4 x 2)			
CodeBookSubsetRestriction bitmap			0x0000 0000 0100 0000			
SNR (Note 2)		dB	7	8	13	14
$\hat{I}_{or}^{(j)}$		dB[mW/15kHz]	-91	-90	-85	-84
$N_{oc}^{(j)}$		dB[mW/15kHz]	-98		-98	
Max number of HARQ transmissions			1			
Physical channel for CQI/PMI reporting			PUSCH (Note3)			
PUCCH Report Type for CQI/PMI			2			
Physical channel for RI reporting			PUCCH Format 2			
PUCCH Report Type for RI			3			
Reporting periodicity		ms	$N_{pd} = 5$			
CQI delay		ms	8			
<i>cqi-pmi-ConfigurationIndex</i>			2			
<i>ri-ConfigIndex</i>			1			
<p>Note 1: Reference measurement channel RC.7 FDD according to Table A.4-1 with one sided dynamic OCNG Pattern OP.1 FDD as described in Annex A.5.1.1.</p> <p>Note 2: For each test, the minimum requirements shall be fulfilled for at least one of the two SNR(s) and the respective wanted signal input level.</p> <p>Note 3: To avoid collisions between CQI/PMI reports and HARQ-ACK it is necessary to report both on PUSCH instead of PUCCH. PDCCH DCI format 0 shall be transmitted in downlink SF#1 and #6 to allow periodic CQI/PMI to multiplex with the HARQ-ACK on PUSCH in uplink SF#0 and #5.</p>						

9.2.3.2 TDD

The following requirements apply to UE Category 2-8. For the parameters specified in table 9.2.3.2-1, and using the downlink physical channels specified in tables C.3.2-1 and C.3.2-2, the reported offset level of the wideband spatial differential CQI for codeword #1 (Table 7.2-2 in TS 36.213 [6]) shall be used to determine the wideband CQI index for codeword #1 as

$$\text{wideband } CQI_1 = \text{wideband } CQI_0 - \text{Codeword 1 offset level}$$

The wideband CQI_1 shall be within the set {median $CQI_1 - 1$, median CQI_1 , median $CQI_1 + 1$ } for more than 90% of the time, where the resulting wideband values CQI_1 shall be used to determine the median CQI values for codeword #1. For both codewords #0 and #1, the PDSCH BLER using the transport format indicated by the respective median $CQI_0 - 1$ and median $CQI_1 - 1$ shall be less than or equal to 0.1. Furthermore, for both codewords #0 and #1, the PDSCH BLER using the transport format indicated by the respective median $CQI_0 + 1$ and median $CQI_1 + 1$ shall be greater than or equal to 0.1.

Table 9.2.3.2-1: PUCCH 1-1 submode 1 static test (TDD)

Parameter		Unit	Test 1		Test 2	
Bandwidth		MHz	10			
PDSCH transmission mode			9			
Uplink downlink configuration			2			
Special subframe configuration			4			
Downlink power allocation	ρ_A	dB	0			
	ρ_B	dB	0			
	P_c	dB	-6			
	σ	dB	-3			
CRS reference signals			Antenna ports 0, 1			
CSI reference signals			Antenna ports 15,...,22			
Beamforming model			As specified in Section B.4.3			
CSI-RS periodicity and subframe offset $T_{\text{CSI-RS}} / \Delta_{\text{CSI-RS}}$			5/3			
CSI reference signal configuration			0			
Propagation condition and antenna configuration			Clause B.1 (8 x 2)			
CodeBookSubsetRestriction bitmap			0x0000 0000 0020 0000 0000 0001 0000			
SNR (Note 2)		dB	4	5	10	11
$\hat{I}_{or}^{(j)}$		dB[mW/15kHz]	-94	-93	-88	-87
$N_{oc}^{(j)}$		dB[mW/15kHz]	-98		-98	
Max number of HARQ transmissions			1			
Physical channel for CQI/PMI reporting			PUSCH (Note 3)			
PUCCH Report Type for CQI/second PMI			2b			
Physical channel for RI reporting			PUSCH			
PUCCH Report Type for RI/ first PMI			5			
Reporting periodicity		ms	$N_{pd} = 5$			
CQI delay		ms	10 or 11			
<i>cqi-pmi-ConfigurationIndex</i>			3			
<i>ri-ConfigIndex</i>			805 (Note 4)			
ACK/NACK feedback mode			Multiplexing			
Note 1: Reference measurement channel RC.7 TDD according to Table A.4-1 with one sided dynamic OCNG Pattern OP.1 TDD as described in Annex A.5.2.1.						
Note 2: For each test, the minimum requirements shall be fulfilled for at least one of the two SNR(s) and the respective wanted signal input level.						
Note 3: To avoid collisions between CQI/PMI reports and HARQ-ACK it is necessary to report both on PUSCH instead of PUCCH. PDCCH DCI format 0 shall be transmitted in downlink SF#3 and #8 to allow periodic CQI/PMI to multiplex with the HARQ-ACK on PUSCH in uplink SF#7 and #2.						
Note 4: RI reporting interval is set to the maximum allowable length of 160ms to minimise collisions between RI, CQI/PMI and HARQ-ACK reports. In the case when all three reports collide, it is expected that CQI/PMI reports will be dropped, while RI and HARQ-ACK will be multiplexed. At eNB, CQI report collection shall be skipped every 160ms during performance verification.						

9.3 CQI reporting under fading conditions

9.3.1 Frequency-selective scheduling mode

The accuracy of sub-band channel quality indicator (CQI) reporting under frequency selective fading conditions is determined by a double-sided percentile of the reported differential CQI offset level 0 per sub-band, and the relative increase of the throughput obtained when transmitting on a randomly selected sub-band among the sub-bands with the highest reported differential CQI offset level the corresponding transport format compared to the case for which a fixed format is transmitted on any sub-band in set S of TS 36.213 [6]. The purpose is to verify that preferred sub-bands can be used for frequently-selective scheduling. To account for sensitivity of the input SNR the sub-band CQI reporting under

frequency selective fading conditions is considered to be verified if the reporting accuracy is met for at least one of two SNR levels separated by an offset of 1 dB.

9.3.1.1 Minimum requirement PUSCH 3-0 (Cell-Specific Reference Symbols)

9.3.1.1.1 FDD

For the parameters specified in Table 9.3.1.1.1-1, and using the downlink physical channels specified in Annex C.3.2, the minimum requirements are specified in Table 9.3.1.1.1-2 and by the following

- a sub-band differential CQI offset level of 0 shall be reported at least $\alpha\%$ of the time but less than $\beta\%$ for each sub-band;
- the ratio of the throughput obtained when transmitting on a randomly selected sub-band among the sub-bands with the highest differential CQI offset level the corresponding TBS and that obtained when transmitting the TBS indicated by the reported wideband CQI median on a randomly selected sub-band in set S shall be $\geq \gamma$;
- when transmitting on a randomly selected sub-band among the sub-bands with the highest differential CQI offset level the corresponding TBS, the average BLER for the indicated transport formats shall be greater or equal to 0.05.

The requirements only apply for sub-bands of full size and the random scheduling across the sub-bands is done by selecting a new sub-band in each TTI for FDD, each available downlink transmission instance for TDD.

Table 9.3.1.1.1-1 Sub-band test for single antenna transmission (FDD)

Parameter		Unit	Test 1		Test 2	
Bandwidth		MHz	10 MHz			
Transmission mode			1 (port 0)			
Downlink power allocation	ρ_A	dB	0			
	ρ_B	dB	0			
	σ	dB	0			
SNR (Note 3)		dB	9	10	14	15
$\hat{I}_{or}^{(j)}$		dB[mW/15kHz]	-89	-88	-84	-83
$N_{oc}^{(j)}$		dB[mW/15kHz]	-98		-98	
Propagation channel			Clause B.2.4 with $\tau_d = 0.45 \mu\text{s}$, $a = 1$, $f_D = 5 \text{ Hz}$			
Antenna configuration			1 x 2			
Reporting interval		ms	5			
CQI delay		ms	8			
Reporting mode			PUSCH 3-0			
Sub-band size		RB	6 (full size)			
Max number of HARQ transmissions			1			
<p>Note 1: If the UE reports in an available uplink reporting instance at subframe SF#n based on CQI estimation at a downlink subframe not later than SF#(n-4), this reported subband or wideband CQI cannot be applied at the eNB downlink before SF#(n+4)</p> <p>Note 2: Reference measurement channel RC.3 FDD according to Table A.4-1 with one/two sided dynamic OCNG Pattern OP.1/2 FDD as described in Annex A.5.1.1/2.</p> <p>Note 3: For each test, the minimum requirements shall be fulfilled for at least one of the two SNR(s) and the respective wanted signal input level.</p>						

Table 9.3.1.1.1-2 Minimum requirement (FDD)

	Test 1	Test 2
α [%]	2	2
β [%]	55	55
γ	1.1	1.1
UE Category	1-8	1-8

9.3.1.1.2 TDD

For the parameters specified in Table 9.3.1.1.2-1, and using the downlink physical channels specified in Annex C.3.2, the minimum requirements are specified in Table 9.3.1.1.2-2 and by the following

- a) a sub-band differential CQI offset level of 0 shall be reported at least α % of the time but less than β % for each sub-band;
- b) the ratio of the throughput obtained when transmitting on a randomly selected sub-band among the sub-bands with the highest differential CQI offset level the corresponding TBS and that obtained when transmitting the TBS indicated by the reported wideband CQI median on a randomly selected sub-band in set S shall be $\geq \gamma$;
- c) when transmitting on a randomly selected sub-band among the sub-bands with the highest differential CQI offset level the corresponding TBS, the average BLER for the indicated transport formats shall be greater or equal to 0.05.

The requirements only apply for sub-bands of full size and the random scheduling across the sub-bands is done by selecting a new sub-band in each TTI for FDD, each available downlink transmission instance for TDD.

Table 9.3.1.1.2-1 Sub-band test for single antenna transmission (TDD)

Parameter		Unit	Test 1		Test 2	
Bandwidth		MHz	10 MHz			
Transmission mode			1 (port 0)			
Downlink power allocation	ρ_A	dB	0			
	ρ_B	dB	0			
	σ	dB	0			
Uplink downlink configuration			2			
Special subframe configuration			4			
SNR (Note 3)		dB	9	10	14	15
$\hat{I}_{or}^{(j)}$		dB[mW/15kHz]	-89	-88	-84	-83
$N_{oc}^{(j)}$		dB[mW/15kHz]	-98		-98	
Propagation channel			Clause B.2.4 with $\tau_d = 0.45 \mu\text{s}$, $a = 1$, $f_D = 5 \text{ Hz}$			
Antenna configuration			1 x 2			
Reporting interval		ms	5			
CQI delay		ms	10 or 11			
Reporting mode			PUSCH 3-0			
Sub-band size		RB	6 (full size)			
Max number of HARQ transmissions			1			
ACK/NACK feedback mode			Multiplexing			
<p>Note 1: If the UE reports in an available uplink reporting instance at subframe SF#n based on CQI estimation at a downlink subframe not later than SF#(n-4), this reported subband or wideband CQI cannot be applied at the eNB downlink before SF#(n+4)</p> <p>Note 2: Reference measurement channel RC.3 TDD according to Table A.4-1 with one/two sided dynamic OCNG Pattern OP.1/2 TDD as described in Annex A.5.2.1/2.</p> <p>Note 3: For each test, the minimum requirements shall be fulfilled for at least one of the two SNR(s) and the respective wanted signal input level.</p>						

Table 9.3.1.1.2-2 Minimum requirement (TDD)

	Test 1	Test 2
α [%]	2	2
β [%]	55	55
γ	1.1	1.1
UE Category	1-8	1-8

9.3.1.2 Minimum requirement PUSCH 3-1 (CSI Reference Symbol)

9.3.1.2.1 FDD

For the parameters specified in Table 9.3.1.2.1-1, and using the downlink physical channels specified in Annex C.3.2, the minimum requirements are specified in Table 9.3.1.2.1-2 and by the following

- a sub-band differential CQI offset level of 0 shall be reported at least α % of the time but less than β % for each sub-band;
- the ratio of the throughput obtained when transmitting on a randomly selected sub-band among the sub-bands with the highest differential CQI offset level the corresponding TBS and that obtained when transmitting the TBS indicated by the reported wideband CQI median on a randomly selected sub-band in set S shall be $\geq \gamma$;

- c) when transmitting on a randomly selected sub-band among the sub-bands with the highest differential CQI offset level the corresponding TBS, the average BLER for the indicated transport formats shall be greater or equal to 0.05.

The requirements only apply for sub-bands of full size and the random scheduling across the sub-bands is done by selecting a new sub-band in each TTI for FDD, each available downlink transmission instance for TDD. Sub-bands of a size smaller than full size are excluded from the test.

Table 9.3.1.2.1-1 Sub-band test for FDD

Parameter		Unit	Test 1		Test 2	
Bandwidth		MHz	10 MHz			
Transmission mode			9			
Downlink power allocation	ρ_A	dB	0			
	ρ_B	dB	0			
	P_c	dB	0			
	σ	dB	0			
SNR (Note 3)		dB	4	5	11	12
$\hat{I}_{or}^{(j)}$		dB[mW/15kHz]	-94	-93	-87	-86
$N_{oc}^{(j)}$		dB[mW/15kHz]	-98		-98	
Propagation channel			Clause B.2.4 with $\tau_d = 0.45 \mu s$, $a = 1$, $f_D = 5$ Hz			
Antenna configuration			2x2			
CRS reference signals			Antenna ports 0			
CSI reference signals			Antenna ports 15, 16			
Beamforming model			As specified in Section B.4.3			
CSI-RS periodicity and subframe offset $T_{CSI-RS} / \Delta_{CSI-RS}$			5/ 1			
CSI-RS reference signal configuration			4			
CodeBookSubsetRestriction bitmap			000001			
Reporting interval (Note 4)		ms	5			
CQI delay		ms	8			
Reporting mode			PUSCH 3-1			
Sub-band size		RB	6 (full size)			
Max number of HARQ transmissions			1			
<p>Note 1: If the UE reports in an available uplink reporting instance at subframe SF#n based on CQI estimation at a downlink subframe not later than SF#(n-4), this reported subband or wideband CQI cannot be applied at the eNB downlink before SF#(n+4)</p> <p>Note 2: Reference measurement channel RC.8 FDD according to Table A.4-1 with one/two sided dynamic OCNG Pattern OP.1/2 FDD as described in Annex A.5.1.1/2.</p> <p>Note 3: For each test, the minimum requirements shall be fulfilled for at least one of the two SNR(s) and the respective wanted signal input level.</p> <p>Note 4: PDCCH DCI format 0 with a trigger for aperiodic CQI shall be transmitted in downlink SF#1 and #6 to allow aperiodic CQI/PMI/RI to be transmitted in uplink SF#0 and #5.</p>						

Table 9.3.1.2.1-2 Minimum requirement (FDD)

	Test 1	Test 2
α [%]	2	2
β [%]	40	40
γ	1.1	1.1
UE Category	1-8	1-8

9.3.1.2.2 TDD

For the parameters specified in Table 9.3.1.2.2-1, and using the downlink physical channels specified in Annex C.3.2, the minimum requirements are specified in Table 9.3.1.2.2-2 and by the following

- a) a sub-band differential CQI offset level of 0 shall be reported at least α % of the time but less than β % for each sub-band;
- b) the ratio of the throughput obtained when transmitting on a randomly selected sub-band among the sub-bands with the highest differential CQI offset level the corresponding TBS and that obtained when transmitting the TBS indicated by the reported wideband CQI median on a randomly selected sub-band in set S shall be $\geq \gamma$;
- c) when transmitting on a randomly selected sub-band among the sub-bands with the highest differential CQI offset level the corresponding TBS, the average BLER for the indicated transport formats shall be greater or equal to 0.05.

The requirements only apply for sub-bands of full size and the random scheduling across the sub-bands is done by selecting a new sub-band in each TTI for FDD, each available downlink transmission instance for TDD. Sub-bands of a size smaller than full size are excluded from the test.

Table 9.3.1.2.2-1 Sub-band test for TDD

Parameter		Unit	Test 1		Test 2	
Bandwidth		MHz	10 MHz			
Transmission mode			9			
Uplink downlink configuration			2			
Special subframe configuration			4			
Downlink power allocation	ρ_A	dB	0			
	ρ_B	dB	0			
	P_C	dB	0			
	σ	dB	0			
SNR (Note 3)		dB	4	5	11	12
$\hat{I}_{or}^{(j)}$		dB[mW/15kHz]	-94	-93	-87	-86
$N_{oc}^{(j)}$		dB[mW/15kHz]	-98		-98	
Propagation channel			Clause B.2.4 with $\tau_d = 0.45 \mu s$, $a = 1$, $f_D = 5$ Hz			
Antenna configuration			2x2			
CRS reference signals			Antenna port 0			
CSI reference signals			Antenna port 15,16			
Beamforming model			As specified in Section B.4.3			
CSI-RS periodicity and subframe offset $T_{CSI-RS} / \Delta_{CSI-RS}$			5/ 3			
CSI-RS reference signal configuration			4			
CodeBookSubsetRestriction bitmap			000001			
Reporting interval (Note 4)		ms	5			
CQI delay		ms	10			
Reporting mode			PUSCH 3-1			
Sub-band size		RB	6 (full size)			
Max number of HARQ transmissions			1			
ACK/NACK feedback mode			Multiplexing			
<p>Note 1: If the UE reports in an available uplink reporting instance at subframe SF#n based on CQI estimation at a downlink subframe not later than SF#(n-4), this reported subband or wideband CQI cannot be applied at the eNB downlink before SF#(n+4)</p> <p>Note 2: Reference measurement channel RC.8 TDD according to Table A.4-1 with one/two sided dynamic OCNB Pattern OP.1/2 TDD as described in Annex A.5.2.1/2.</p> <p>Note 3: For each test, the minimum requirements shall be fulfilled for at least one of the two SNR(s) and the respective wanted signal input level.</p> <p>Note 4: PDCCH DCI format 0 with a trigger for aperiodic CQI shall be transmitted in downlink SF#3 and #8 to allow aperiodic CQI/PMI/RI to be transmitted on uplink SF#2 and #7.</p>						

Table 9.3.1.2.2-2 Minimum requirement (TDD)

	Test 1	Test 2
α [%]	2	2
β [%]	40	40
γ	1.1	1.1
UE Category	1-8	1-8

9.3.2 Frequency non-selective scheduling mode

The reporting accuracy of the channel quality indicator (CQI) under frequency non-selective fading conditions is determined by the reporting variance, and the relative increase of the throughput obtained when the transport format transmitted is that indicated by the reported CQI compared to the case for which a fixed transport format configured according to the reported median CQI is transmitted. In addition, the reporting accuracy is determined by a minimum BLER using the transport formats indicated by the reported CQI. The purpose is to verify that the UE is tracking the channel variations and selecting the largest transport format possible according to the prevailing channel state for frequently non-selective scheduling. To account for sensitivity of the input SNR the CQI reporting under frequency non-selective fading conditions is considered to be verified if the reporting accuracy is met for at least one of two SNR levels separated by an offset of 1 dB.

9.3.2.1 Minimum requirement PUCCH 1-0 (Cell-Specific Reference Symbol)

9.3.2.1.1 FDD

For the parameters specified in Table 9.3.2.1.1-1, and using the downlink physical channels specified in Annex C.3.2, the minimum requirements are specified in Table 9.3.2.1.1-2 and by the following

- a CQI index not in the set {median CQI -1, median CQI, median CQI +1} shall be reported at least α % of the time;
- the ratio of the throughput obtained when transmitting the transport format indicated by each reported wideband CQI index and that obtained when transmitting a fixed transport format configured according to the wideband CQI median shall be $\geq \gamma$;
- when transmitting the transport format indicated by each reported wideband CQI index, the average BLER for the indicated transport formats shall be greater or equal to 0.02

Table 9.3.2.1.1-1 Fading test for single antenna (FDD)

Parameter		Unit	Test 1		Test 2	
Bandwidth		MHz	10 MHz			
Transmission mode			1 (port 0)			
Downlink power allocation	ρ_A	dB	0			
	ρ_B	dB	0			
	σ	dB	0			
SNR (Note 3)		dB	6	7	12	13
$\hat{I}_{or}^{(j)}$		dB[mW/15kHz]	-92	-91	-86	-85
$N_{oc}^{(j)}$		dB[mW/15kHz]	-98		-98	
Propagation channel			EPA5			
Correlation and antenna configuration			High (1 x 2)			
Reporting mode			PUCCH 1-0			
Reporting periodicity		ms	$N_{pd} = 2$			
CQI delay		ms	8			
Physical channel for CQI reporting			PUSCH (Note 4)			
PUCCH Report Type			4			
<i>cqi-pmi-ConfigurationIndex</i>			1			
Max number of HARQ transmissions			1			
<p>Note 1: If the UE reports in an available uplink reporting instance at subframe SF#n based on CQI estimation at a downlink SF not later than SF#(n-4), this reported wideband CQI cannot be applied at the eNB downlink before SF#(n+4)</p> <p>Note 2: Reference measurement channel RC.1 FDD according to Table A.4-1 for Category 2-8 with one sided dynamic OCNG Pattern OP.1 FDD as described in Annex A.5.1.1 and RC.4 FDD according to Table A.4-1 for Category 1 with one/two sided dynamic OCNG Pattern OP.1/2 FDD as described in Annex A.5.1.1/2.</p> <p>Note 3: For each test, the minimum requirements shall be fulfilled for at least one of the two SNR(s) and the respective wanted signal input level.</p> <p>Note 4: To avoid collisions between CQI reports and HARQ-ACK it is necessary to report both on PUSCH instead of PUCCH. PDCCH DCI format 0 shall be transmitted in downlink SF#1, #3, #7 and #9 to allow periodic CQI to multiplex with the HARQ-ACK on PUSCH in uplink subframe SF#5, #7, #1 and #3.</p>						

Table 9.3.2.1.1-2 Minimum requirement (FDD)

	Test 1	Test 2
α [%]	20	20
γ	1.05	1.05
UE Category	1-8	1-8

9.3.2.1.2 TDD

For the parameters specified in Table 9.3.2.1.2-1, and using the downlink physical channels specified in Annex C.3.2, the minimum requirements are specified in Table 9.3.2.1.2-2 and by the following

- a CQI index not in the set {median CQI -1, median CQI, median CQI +1} shall be reported at least α % of the time;
- the ratio of the throughput obtained when transmitting the transport format indicated by each reported wideband CQI index and that obtained when transmitting a fixed transport format configured according to the wideband CQI median shall be $\geq \gamma$;

c) when transmitting the transport format indicated by each reported wideband CQI index, the average BLER for the indicated transport formats shall be greater or equal to 0.02.

Table 9.3.2.1.2-1 Fading test for single antenna (TDD)

Parameter		Unit	Test 1		Test 2	
Bandwidth		MHz	10 MHz			
Transmission mode			1 (port 0)			
Downlink power allocation	ρ_A	dB	0			
	ρ_B	dB	0			
	σ	dB	0			
Uplink downlink configuration			2			
Special subframe configuration			4			
SNR (Note 3)		dB	6	7	12	13
$\hat{I}_{or}^{(j)}$		dB[mW/15kHz]	-92	-91	-86	-85
$N_{oc}^{(j)}$		dB[mW/15kHz]	-98		-98	
Propagation channel			EPA5			
Correlation and antenna configuration			High (1 x 2)			
Reporting mode			PUCCH 1-0			
Reporting periodicity		ms	$N_{pd} = 5$			
CQI delay		ms	10 or 11			
Physical channel for CQI reporting			PUSCH (Note 4)			
PUCCH Report Type			4			
<i>cqi-pmi-ConfigurationIndex</i>			3			
Max number of HARQ transmissions			1			
ACK/NACK feedback mode			Multiplexing			
<p>Note 1: If the UE reports in an available uplink reporting instance at subframe SF#n based on CQI estimation at a downlink SF not later than SF#(n-4), this reported wideband CQI cannot be applied at the eNB downlink before SF#(n+4).</p> <p>Note 2: Reference measurement channel RC.1 TDD according to Table A.4-1 for Category 2-8 with one sided dynamic OCNG Pattern OP.1 TDD as described in Annex A.5.2.1 and RC.4 TDD according to Table A.4-1 for Category 1 with one/two sided dynamic OCNG Pattern OP.1/2 TDD as described in Annex A.5.2.1/2.</p> <p>Note 3: For each test, the minimum requirements shall be fulfilled for at least one of the two SNR(s) and the respective wanted signal input level.</p> <p>Note 4: To avoid collisions between CQI reports and HARQ-ACK it is necessary to report both on PUSCH instead of PUCCH. PDCCH DCI format 0 shall be transmitted in downlink SF#3 and #8 to allow periodic CQI to multiplex with the HARQ-ACK on PUSCH in uplink subframe SF#7 and #2.</p>						

Table 9.3.2.1.2-2 Minimum requirement (TDD)

	Test 1	Test 2
α [%]	20	20
γ	1.05	1.05
UE Category	1-8	1-8

9.3.2.2 Minimum requirement PUCCH 1-1 (CSI Reference Symbol)

9.3.2.2.1 FDD

For the parameters specified in Table 9.3.2.2.1-1, and using the downlink physical channels specified in Annex C.3.2, the minimum requirements are specified in Table 9.3.2.2.1-2 and by the following

- a CQI index not in the set {median CQI -1, median CQI, median CQI +1} shall be reported at least α % of the time;
- the ratio of the throughput obtained when transmitting the transport format indicated by each reported wideband CQI index and that obtained when transmitting a fixed transport format configured according to the wideband CQI median shall be $\geq \gamma$;
- when transmitting the transport format indicated by each reported wideband CQI index, the average BLER for the indicated transport formats shall be greater or equal to 0.02.

Table 9.3.2.2.1-1 Fading test for FDD

Parameter		Unit	Test 1		Test 2	
Bandwidth		MHz	10 MHz			
Transmission mode			9			
Downlink power allocation	ρ_A	dB	0			
	ρ_B	dB	0			
	P_C	dB	-3			
	σ	dB	-3			
SNR (Note 3)		dB	2	3	7	8
$\hat{I}_{or}^{(j)}$		dB[mW/15kHz]	-96	-95	-91	-90
$N_{oc}^{(j)}$		dB[mW/15kHz]	-98		-98	
Propagation channel			EPA5			
Correlation and antenna configuration			ULA High (4 x 2)			
Cell-specific reference signals			Antenna ports 0,1			
CSI reference signals			Antenna ports 15,...,18			
Beamforming model			As specified in Section B.4.3			
CSI-RS periodicity and subframe offset $T_{CSI-RS} / \Delta_{CSI-RS}$			5/1			
CSI-RS reference signal configuration			2			
CodeBookSubsetRestriction bitmap			0x0000 0000 0000 0001			
Reporting mode			PUCCH 1-1			
Reporting periodicity		ms	$N_{pd} = 5$			
CQI delay		ms	8			
Physical channel for CQI/ PMI reporting			PUSCH (Note 4)			
PUCCH Report Type for CQI/PMI			2			
PUCCH channel for RI reporting			PUCCH Format 2			
PUCCH report type for RI			3			
<i>cqi-pmi-ConfigurationIndex</i>			2			
<i>ri-ConfigIndex</i>			1			
Max number of HARQ transmissions			1			
<p>Note 1: If the UE reports in an available uplink reporting instance at subframe SF#n based on CQI estimation at a downlink SF not later than SF#(n-4), this reported wideband CQI cannot be applied at the eNB downlink before SF#(n+4)</p> <p>Note 2: Reference measurement channel RC.7 FDD according to Table A.4-1 with one sided dynamic OCNG Pattern OP.1 FDD as described in Annex A.5.1.1.</p> <p>Note 3: For each test, the minimum requirements shall be fulfilled for at least one of the two SNR(s) and the respective wanted signal input level.</p> <p>Note 4: To avoid collisions between CQI/ PMI reports and HARQ-ACK it is necessary to report both on PUSCH instead of PUCCH. PDCCH DCI format 0 shall be transmitted in downlink SF#1 and #6 to allow periodic CQI/ PMI to multiplex with the HARQ-ACK on PUSCH in uplink subframe SF#0 and #5.</p>						

Table 9.3.2.2.1-2 Minimum requirement (FDD)

	Test 1	Test 2
α [%]	20	20
γ	1.05	1.05
UE Category	2-8	2-8

9.3.2.2.2 TDD

For the parameters specified in Table 9.3.2.2.2-1, and using the downlink physical channels specified in Annex C.3.2, the minimum requirements are specified in Table 9.3.2.2.2-2 and by the following

- a) a CQI index not in the set {median CQI -1, median CQI, median CQI +1} shall be reported at least α % of the time;
- b) the ratio of the throughput obtained when transmitting the transport format indicated by each reported wideband CQI index and that obtained when transmitting a fixed transport format configured according to the wideband CQI median shall be $\geq \gamma$;
- c) when transmitting the transport format indicated by each reported wideband CQI index, the average BLER for the indicated transport formats shall be greater or equal to 0.02.

Table 9.3.2.2-1 Fading test for TDD

Parameter		Unit	Test 1		Test 2	
Bandwidth		MHz	10 MHz			
Transmission mode			9			
Uplink downlink configuration			2			
Special subframe configuration			4			
Downlink power allocation	ρ_A	dB	0			
	ρ_B	dB	0			
	P_C	dB	-6			
	σ	dB	-3			
SNR (Note 3)		dB	1	2	7	8
$\hat{I}_{or}^{(j)}$		dB[mW/15kHz]	-97	-96	-91	-90
$N_{oc}^{(j)}$		dB[mW/15kHz]	-98		-98	
Propagation channel			EPA5			
Correlation and antenna configuration			XP High (8 x 2)			
CRS reference signals			Antenna ports 0, 1			
CSI reference signals			Antenna ports 15,...,22			
Beamforming Model			As specified in Section B.4.3			
CSI-RS periodicity and subframe offset $T_{CSI-RS} / \Delta_{CSI-RS}$			5/ 3			
CSI-RS reference signal configuration			2			
CodeBookSubsetRestriction bitmap			0x0000 0000 0000 0020 0000 0000 0001			
Reporting mode			PUCCH 1-1 (Sub-mode: 2)			
Reporting periodicity		ms	$N_{pd} = 5$			
CQI delay		ms	10			
Physical channel for CQI/ PMI reporting			PUSCH (Note 4)			
PUCCH Report Type for CQI/ PMI			2c			
Physical channel for RI reporting			PUCCH Format 2			
PUCCH report type for RI			3			
<i>cqi-pmi-ConfigurationIndex</i>			3			
<i>ri-ConfigIndex</i>			805 (Note 5)			
Max number of HARQ transmissions			1			
ACK/NACK feedback mode			Multiplexing			
<p>Note 1: If the UE reports in an available uplink reporting instance at subframe SF#n based on CQI estimation at a downlink SF not later than SF#(n-4), this reported wideband CQI cannot be applied at the eNB downlink before SF#(n+4)</p> <p>Note 2: Reference measurement channel RC.7 TDD according to Table A.4-1 with one sided dynamic OCNG Pattern OP.1 TDD as described in Annex A.5.2.1.</p> <p>Note 3: For each test, the minimum requirements shall be fulfilled for at least one of the two SNR(s) and the respective wanted signal input level.</p> <p>Note 4: To avoid collisions between CQI/ PMI reports and HARQ-ACK it is necessary to report both on PUSCH instead of PUCCH. PDCCH DCI format 0 shall be transmitted in downlink SF#3 and #8 to allow periodic CQI/ PMI to multiplex with the HARQ-ACK on PUSCH in uplink subframe SF#2 and #7.</p> <p>Note 5: RI reporting interval is set to the maximum allowable length of 160ms to minimise collisions between RI, CQI/PMI and HARQ-ACK reports. In the case when all three reports collide, it is expected that CQI/PMI reports will be dropped, while RI and HARQ-ACK will be multiplexed. At eNB, CQI report collection shall be skipped every 160ms during performance verification and the reported CQI in subframe SF#7 of the previous frame is applied in downlink subframes until a new CQI (after CQI/PMI dropping) is available.</p>						

Table 9.3.2.2-2 Minimum requirement (TDD)

	Test 1	Test 2
α [%]	20	20
γ	1.05	1.05
UE Category	2-8	2-8

9.3.3 Frequency-selective interference

The accuracy of sub-band channel quality indicator (CQI) reporting under frequency selective interference conditions is determined by a percentile of the reported differential CQI offset level +2 for a preferred sub-band, and the relative increase of the throughput obtained when transmitting on a randomly selected sub-band among the sub-bands with the highest reported differential CQI offset level the corresponding transport format compared to the case for which a fixed format is transmitted on any sub-band in set S of TS 36.213 [6]. The purpose is to verify that preferred sub-bands are used for frequently-selective scheduling under frequency-selective interference conditions.

9.3.3.1 Minimum requirement PUSCH 3-0 (Cell-Specific Reference Symbol)

9.3.3.1.1 FDD

For the parameters specified in Table 9.3.3.1.1-1, and using the downlink physical channels specified in Annex C.3.2, the minimum requirements are specified in Table 9.3.3.1.1-2 and by the following

- a sub-band differential CQI offset level of +2 shall be reported at least $\alpha\%$ for at least one of the sub-bands of full size at the channel edges;
- the ratio of the throughput obtained when transmitting on a randomly selected sub-band among the sub-bands with the highest differential CQI offset level the corresponding TBS and that obtained when transmitting the TBS indicated by the reported wideband CQI median on a randomly selected sub-band in set S shall be $\geq \gamma$;

The requirements only apply for sub-bands of full size and the random scheduling across the sub-bands is done by selecting a new sub-band in each TTI for FDD, each available downlink transmission instance for TDD. Sub-bands of a size smaller than full size are excluded from the test.

Table 9.3.3.1.1-1 Sub-band test for single antenna transmission (FDD)

Parameter	Unit	Test 1	Test 2
Bandwidth	MHz	10 MHz	10 MHz
Transmission mode		1 (port 0)	1 (port 0)
Downlink power allocation	ρ_A	dB	0
	ρ_B	dB	0
	σ	dB	0
$I_{ot}^{(j)}$ for RB 0...5	dB[mW/15kHz]	-102	-93
$I_{ot}^{(j)}$ for RB 6...41	dB[mW/15kHz]	-93	-93
$I_{ot}^{(j)}$ for RB 42...49	dB[mW/15kHz]	-93	-102
$\hat{I}_{or}^{(j)}$	dB[mW/15kHz]	-94	-94
Max number of HARQ transmissions		1	
Propagation channel		Clause B.2.4 with $\tau_d = 0.45 \mu s$, $a = 1$, $f_D = 5$ Hz	
Reporting interval	ms	5	
Antenna configuration		1 x 2	
CQI delay	ms	8	
Reporting mode		PUSCH 3-0	
Sub-band size	RB	6 (full size)	
Note 1:	If the UE reports in an available uplink reporting instance at subframe SF#n based on CQI estimation at a downlink subframe not later than SF#(n-4), this reported subband or wideband CQI cannot be applied at the eNB downlink before SF#(n+4)		
Note 2:	Reference measurement channel RC.3 FDD according to Table A.4-1 with one/two sided dynamic OCNG Pattern OP.1/2 FDD as described in Annex A.5.1.1/2.		

Table 9.3.3.1.1-2 Minimum requirement (FDD)

	Test 1	Test 2
α [%]	60	60
γ	1.6	1.6
UE Category	1-8	1-8

9.3.3.1.2 TDD

For the parameters specified in Table 9.3.3.1.2-1, and using the downlink physical channels specified in Annex C.3.2, the minimum requirements are specified in Table 9.3.3.1.2-2 and by the following

- a sub-band differential CQI offset level of +2 shall be reported at least α % for at least one of the sub-bands of full size at the channel edges;
- the ratio of the throughput obtained when transmitting on a randomly selected sub-band among the sub-bands with the highest differential CQI offset level the corresponding TBS and that obtained when transmitting the TBS indicated by the reported wideband CQI median on a randomly selected sub-band in set S shall be $\geq \gamma$;

The requirements only apply for sub-bands of full size and the random scheduling across the sub-bands is done by selecting a new sub-band in each TTI for FDD, each available downlink transmission instance for TDD. Sub-bands of a size smaller than full size are excluded from the test.

Table 9.3.3.1.2-1 Sub-band test for single antenna transmission (TDD)

Parameter	Unit	Test 1	Test 2
Bandwidth	MHz	10 MHz	10 MHz
Transmission mode		1 (port 0)	1 (port 0)
Downlink power allocation	ρ_A	dB	0
	ρ_B	dB	0
	σ	dB	0
Uplink downlink configuration		2	
Special subframe configuration		4	
$I_{ot}^{(j)}$ for RB 0...5	dB[mW/15kHz]	-102	-93
$I_{ot}^{(j)}$ for RB 6...41	dB[mW/15kHz]	-93	-93
$I_{ot}^{(j)}$ for RB 42...49	dB[mW/15kHz]	-93	-102
$\hat{I}_{or}^{(j)}$	dB[mW/15kHz]	-94	-94
Max number of HARQ transmissions		1	
Propagation channel		Clause B.2.4 with $\tau_d = 0.45 \mu s$, $a = 1$, $f_D = 5$ Hz	
Antenna configuration		1 x 2	
Reporting interval	ms	5	
CQI delay	ms	10 or 11	
Reporting mode		PUSCH 3-0	
Sub-band size	RB	6 (full size)	
ACK/NACK feedback mode		Multiplexing	
Note 1:	If the UE reports in an available uplink reporting instance at subframe SF#n based on CQI estimation at a downlink subframe not later than SF#(n-4), this reported subband or wideband CQI cannot be applied at the eNB downlink before SF#(n+4).		
Note 2:	Reference measurement channel RC.3 TDD according to table A.4-1 with one/two sided dynamic OCNG Pattern OP.1/2 TDD as described in Annex A.5.2.1/2.		

Table 9.3.3.1.2-2 Minimum requirement (TDD)

	Test 1	Test 2
α [%]	60	60
γ	1.6	1.6
UE Category	1-8	1-8

9.3.3.2 Void

9.3.3.2.1 Void

9.3.3.2.2 Void

9.3.4 UE-selected subband CQI

The accuracy of UE-selected subband channel quality indicator (CQI) reporting under frequency-selective fading conditions is determined by the relative increase of the throughput obtained when transmitting on the UE-selected subbands with the corresponding transport format compared to the case for which a fixed format is transmitted on any subband in set S of TS 36.213 [6]. The purpose is to verify that correct subbands are accurately reported for frequency-selective scheduling. To account for sensitivity of the input SNR the subband CQI reporting under frequency-selective fading conditions is considered to be verified if the reporting accuracy is met for at least one of two SNR levels separated by an offset of 1 dB.

9.3.4.1 Minimum requirement PUSCH 2-0 (Cell-Specific Reference Symbols)

9.3.4.1.1 FDD

For the parameters specified in Table 9.3.4.1.1-1, and using the downlink physical channels specified in Annex C.3.2, the minimum requirements are specified in Table 9.3.4.1.1-2 and by the following

- a) the ratio of the throughput obtained when transmitting on a randomly selected subband among the best M subbands reported by the UE the corresponding TBS and that obtained when transmitting the TBS indicated by the reported wideband CQI median on a randomly selected subband in set S shall be $\geq \gamma$;

The requirements only apply for subbands of full size and the random scheduling across the subbands is done by selecting a new subband in each TTI for FDD. The transport block size TBS (wideband CQI median) is that resulting from the code rate which is closest to that indicated by the wideband CQI median and the N_{PRB} entry in Table 7.1.7.2.1-1 of TS 36.213 [6] that corresponds to the subband size.

Table 9.3.4.1.1-1 Subband test for single antenna transmission (FDD)

Parameter		Unit	Test 1		Test 2	
Bandwidth		MHz	10 MHz			
Transmission mode			1 (port 0)			
Downlink power allocation	ρ_A	dB	0			
	ρ_B	dB	0			
	σ	dB	0			
SNR (Note 3)		dB	9	10	14	15
$\hat{I}_{or}^{(j)}$		dB[mW/15kHz]	-89	-88	-84	-83
$N_{oc}^{(j)}$		dB[mW/15kHz]	-98		-98	
Propagation channel			Clause B.2.4 with $\tau_d = 0.45 \mu\text{s}$, $a = 1$, $f_D = 5 \text{ Hz}$			
Reporting interval		ms	5			
CQI delay		ms	8			
Reporting mode			PUSCH 2-0			
Max number of HARQ transmissions			1			
Subband size (k)		RBs	3 (full size)			
Number of preferred subbands (M)			5			
<p>Note 1: If the UE reports in an available uplink reporting instance at subframe SF#n based on CQI estimation at a downlink subframe not later than SF#$(n-4)$, this reported subband or wideband CQI cannot be applied at the eNB downlink before SF#$(n+4)$</p> <p>Note 2: Reference measurement channel RC.5 FDD according to Table A.4-1 with one/two sided dynamic OCNG Pattern OP.1/2 FDD as described in Annex A.5.1.1/2.</p> <p>Note 3: For each test, the minimum requirements shall be fulfilled for at least one of the two SNR(s) and the respective wanted signal input level.</p>						

Table 9.3.4.1.1-2 Minimum requirement (FDD)

	Test 1	Test 2
γ	1.2	1.2
UE Category	1-8	1-8

9.3.4.1.2 TDD

For the parameters specified in Table 9.3.4.1.2-1, and using the downlink physical channels specified in Annex C.3.2, the minimum requirements are specified in Table 9.3.4.1.2-2 and by the following

- a) the ratio of the throughput obtained when transmitting on a randomly selected subband among the best M subbands reported by the UE the corresponding TBS and that obtained when transmitting the TBS indicated by the reported wideband CQI median on a randomly selected subband in set S shall be $\geq \gamma$;

The requirements only apply for subbands of full size and the random scheduling across the subbands is done by selecting a new subband in each available downlink transmission instance for TDD. The transport block size TBS (wideband CQI median) is that resulting from the code rate which is closest to that indicated by the wideband CQI median and the N_{PRB} entry in Table 7.1.7.2.1-1 of TS 36.213 [6] that corresponds to the subband size.

Table 9.3.4.1.2-1 Sub-band test for single antenna transmission (TDD)

Parameter		Unit	Test 1		Test 2	
Bandwidth		MHz	10 MHz			
Transmission mode			1 (port 0)			
Downlink power allocation	ρ_A	dB	0			
	ρ_B	dB	0			
	σ	dB	0			
Uplink downlink configuration			2			
Special subframe configuration			4			
SNR (Note 3)		dB	9	10	14	15
$\hat{I}_{or}^{(j)}$		dB[mW/15kHz]	-89	-88	-84	-83
$N_{oc}^{(j)}$		dB[mW/15kHz]	-98		-98	
Propagation channel			Clause B.2.4 with $\tau_d = 0.45 \mu\text{s}$, $a = 1$, $f_D = 5 \text{ Hz}$			
Reporting interval		ms	5			
CQI delay		ms	10 or 11			
Reporting mode			PUSCH 2-0			
Max number of HARQ transmissions			1			
Subband size (k)		RBs	3 (full size)			
Number of preferred subbands (M)			5			
ACK/NACK feedback mode			Multiplexing			
<p>Note 1: If the UE reports in an available uplink reporting instance at subframe SF#n based on CQI estimation at a downlink subframe not later than SF#($n-4$), this reported subband or wideband CQI cannot be applied at the eNB downlink before SF#($n+4$)</p> <p>Note 2: Reference measurement channel RC.5 TDD according to Table A.4-1 with one/two sided dynamic OCNG Pattern OP.1/2 TDD as described in Annex A.5.2.1/2.</p> <p>Note 3: For each test, the minimum requirements shall be fulfilled for at least one of the two SNR(s) and the respective wanted signal input level.</p>						

Table 9.3.4.1.2-2 Minimum requirement (TDD)

	Test 1	Test 2
γ	1.2	1.2
UE Category	1-8	1-8

9.3.4.2 Minimum requirement PUCCH 2-0 (Cell-Specific Reference Symbols)

9.3.4.2.1 FDD

For the parameters specified in Table 9.3.4.2.1-1, and using the downlink physical channels specified in Annex C.3.2, the minimum requirements are specified in Table 9.3.4.2.1-2 and by the following

- a) the ratio of the throughput obtained when transmitting on subbands reported by the UE the corresponding TBS and that obtained when transmitting the TBS indicated by the reported wideband CQI median on a randomly selected subband in set S shall be $\geq \gamma$;

The requirements only apply for subbands of full size and the random scheduling across the subbands is done by selecting a new subband in each TTI for FDD. The transport block size TBS (wideband CQI median) is that resulting from the code rate which is closest to that indicated by the wideband CQI median and the N_{PRB} entry in Table 7.1.7.2.1-1 of TS 36.213 [6] that corresponds to the subband size.

Table 9.3.4.2.1-1 Subband test for single antenna transmission (FDD)

Parameter	Unit	Test 1		Test 2	
Bandwidth	MHz	10 MHz			
Transmission mode		1 (port 0)			
Downlink power allocation	ρ_A	dB			
	ρ_B	dB			
	σ	dB			
SNR (Note 3)	dB	8	9	13	14
$\hat{I}_{or}^{(j)}$	dB[mW/15kHz]	-90	-89	-85	-84
$N_{oc}^{(j)}$	dB[mW/15kHz]	-98		-98	
Propagation channel		Clause B.2.4 with $\tau_d = 0.45 \mu s$, $a = 1$, $f_D = 5$ Hz			
Reporting periodicity	ms	$N_P = 2$			
CQI delay	ms	8			
Physical channel for CQI reporting		PUSCH (Note 4)			
PUCCH Report Type for wideband CQI		4			
PUCCH Report Type for subband CQI		1			
Max number of HARQ transmissions		1			
Subband size (k)	RBs	6 (full size)			
Number of bandwidth parts (J)		3			
K		1			
$cqi-pmi-ConfigIndex$		1			
Note 1:	If the UE reports in an available uplink reporting instance at subframe SF#n based on CQI estimation at a downlink subframe not later than SF#(n-4), this reported subband or wideband CQI cannot be applied at the eNB downlink before SF#(n+4)				
Note 2:	Reference measurement channel RC.3 FDD according to Table A.4-1 with one/two sided dynamic OCNG Pattern OP.1/2 FDD as described in Annex A.5.1.1/2.				
Note 3:	For each test, the minimum requirements shall be fulfilled for at least one of the two SNR(s) and the respective wanted signal input level.				
Note 4:	To avoid collisions between CQI reports and HARQ-ACK it is necessary to report both on PUSCH instead of PUCCH. PDCCH DCI format 0 shall be transmitted in downlink SF#1, #3, #7 and #9 to allow periodic CQI to multiplex with the HARQ-ACK on PUSCH in uplink subframe SF#5, #7, #1 and #3.				
Note 5:	CQI reports for the short subband (having 2RBs in the last bandwidth part) are to be disregarded and data scheduling according to the most recent subband CQI report for bandwidth part with $j=1$.				
Note 6:	In the case where wideband CQI is reported, data is to be scheduled according to the most recently used subband CQI report.				

Table 9.3.4.2.1-2 Minimum requirement (FDD)

	Test 1	Test 2
γ	1.15	1.15
UE Category	1-8	1-8

9.3.4.2.2 TDD

For the parameters specified in Table 9.3.4.2.2-1, and using the downlink physical channels specified in Annex C.3.2, the minimum requirements are specified in Table 9.3.4.2.2-2 and by the following

- a) the ratio of the throughput obtained when transmitting on subbands reported by the UE the corresponding TBS and that obtained when transmitting the TBS indicated by the reported wideband CQI median on a randomly selected subband in set S shall be $\geq \gamma$;

The requirements only apply for subbands of full size and the random scheduling across the subbands is done by selecting a new subband in each available downlink transmission instance for TDD. The transport block size TBS (wideband CQI median) is that resulting from the code rate which is closest to that indicated by the wideband CQI median and the N_{PRB} entry in Table 7.1.7.2.1-1 of TS 36.213 [6] that corresponds to the subband size.

Table 9.3.4.2.2-1 Sub-band test for single antenna transmission (TDD)

Parameter	Unit	Test 1		Test 2	
Bandwidth	MHz	10 MHz			
Transmission mode		1 (port 0)			
Downlink power allocation	ρ_A	dB	0		
	ρ_B	dB	0		
	σ	dB	0		
Uplink downlink configuration		2			
Special subframe configuration		4			
SNR (Note 3)	dB	8	9	13	14
$\hat{I}_{or}^{(j)}$	dB[mW/15kHz]	-90	-89	-85	-84
$N_{oc}^{(j)}$	dB[mW/15kHz]	-98		-98	
Propagation channel		Clause B.2.4 with $\tau_d = 0.45 \mu\text{s}$, $a = 1$, $f_D = 5 \text{ Hz}$			
Reporting periodicity	ms	$N_p = 5$			
CQI delay	ms	10 or 11			
Physical channel for CQI reporting		PUSCH (Note 4)			
PUCCH Report Type for wideband CQI		4			
PUCCH Report Type for subband CQI		1			
Max number of HARQ transmissions		1			
Subband size (k)	RBs	6 (full size)			
Number of bandwidth parts (J)		3			
K		1			
<i>cqi-pmi-ConfigIndex</i>		3			
ACK/NACK feedback mode		Multiplexing			
Note 1:	If the UE reports in an available uplink reporting instance at subframe SF#n based on CQI estimation at a downlink subframe not later than SF#(n-4), this reported subband or wideband CQI cannot be applied at the eNB downlink before SF#(n+4).				
Note 2:	Reference measurement channel RC.3 TDD according to Table A.4-1 with one/two sided dynamic OCNG Pattern OP.1/2 TDD as described in Annex A.5.2.1/2.				
Note 3:	For each test, the minimum requirements shall be fulfilled for at least one of the two SNR(s) and the respective wanted signal input level.				
Note 4:	To avoid collisions between CQI reports and HARQ-ACK it is necessary to report both on PUSCH instead of PUCCH. PDCCH DCI format 0 shall be transmitted in downlink SF#3 and #8 to allow periodic CQI to multiplex with the HARQ-ACK on PUSCH in uplink subframe SF#7 and #2.				
Note 5:	CQI reports for the short subband (having 2RBs in the last bandwidth part) are to be disregarded and data scheduling according to the most recent subband CQI report for bandwidth part with $j=1$.				
Note 6:	In the case where wideband CQI is reported, data is to be scheduled according to the most recently used subband CQI report.				

Table 9.3.4.2.2-2 Minimum requirement (TDD)

	Test 1	Test 2
γ	1.15	1.15
UE Category	1-8	1-8

9.4 Reporting of Precoding Matrix Indicator (PMI)

The minimum performance requirements of PMI reporting are defined based on the precoding gain, expressed as the relative increase in throughput when the transmitter is configured according to the UE reports compared to the case when the transmitter is using random precoding, respectively. When the transmitter uses random precoding, for each PDSCH allocation a precoder is randomly generated and applied to the PDSCH. A fixed transport format (FRC) is configured for all requirements.

The requirements for transmission mode 6 and transmission mode 9 with 4 TX are specified in terms of the ratio

$$\gamma = \frac{t_{ue}}{t_{rnd}}$$

In the definition of γ , for PUSCH 3-1 single PMI and PUSCH 1-2 multiple PMI requirements, t_{rnd} is 60% of the maximum throughput obtained at SNR_{rnd} using random precoding, and t_{ue} the throughput measured at SNR_{rnd} with precoders configured according to the UE reports;

For the PUCCH 2-1 single PMI requirement, t_{rnd} is 60% of the maximum throughput obtained at SNR_{rnd} using random precoding on a randomly selected full-size subband in set S subbands, and t_{ue} the throughput measured at SNR_{rnd} with both the precoder and the preferred full-size subband applied according to the UE reports;

For PUSCH 2-2 multiple PMI requirements, t_{rnd} is 60% of the maximum throughput obtained at SNR_{rnd} using random precoding on a randomly selected full-size subband in set S subbands, and t_{ue} the throughput measured at SNR_{rnd} with both the subband precoder and a randomly selected full-size subband (within the preferred subbands) applied according to the UE reports.

The requirements for transmission mode 9 with 8 TX are specified in terms of the ratio

$$\gamma = \frac{t_{ue, follow1, follow2}}{t_{rnd1, rnd2}}$$

In the definition of γ , for PUSCH 3-1 single PMI and PUSCH 1-2 multiple PMI requirements, $t_{follow1, follow2}$ is 70% of the maximum throughput obtained at $SNR_{follow1, follow2}$ using the precoders configured according to the UE reports, and $t_{rnd1, rnd2}$ is the throughput measured at $SNR_{follow1, follow2}$ with random precoding .

9.4.1 Single PMI

9.4.1.1 Minimum requirement PUSCH 3-1 (Cell-Specific Reference Symbols)

9.4.1.1.1 FDD

For the parameters specified in Table 9.4.1.1.1-1, and using the downlink physical channels specified in Annex C.3.2, the minimum requirements are specified in Table 9.4.1.1.1-2.

Table 9.4.1.1.1-1 PMI test for single-layer (FDD)

Parameter		Unit	Test 1
Bandwidth		MHz	10
Transmission mode			6
Propagation channel			EVA5
Precoding granularity		PRB	50
Correlation and antenna configuration			Low 2 x 2
Downlink power allocation	ρ_A	dB	-3
	ρ_B	dB	-3
	σ	dB	0
$N_{oc}^{(j)}$		dB[mW/15kHz]	-98
Reporting mode			PUSCH 3-1
Reporting interval		ms	1
PMI delay (Note 2)		ms	8
Measurement channel			R. 10 FDD
OCNG Pattern			OP.1 FDD
Max number of HARQ transmissions			4
Redundancy version coding sequence			{0,1,2,3}
Note 1: For random precoder selection, the precoder shall be updated in each TTI (1 ms granularity). Note 2: If the UE reports in an available uplink reporting instance at subframe SF#n based on PMI estimation at a downlink SF not later than SF#(n-4), this reported PMI cannot be applied at the eNB downlink before SF#(n+4).			

Table 9.4.1.1.1-2 Minimum requirement (FDD)

Parameter	Test 1
γ	1.1
UE Category	1-8

9.4.1.1.2 TDD

For the parameters specified in Table 9.4.1.1.2-1, and using the downlink physical channels specified in Annex C.3.2, the minimum requirements are specified in 9.4.1.1.2-2.

Table 9.4.1.1.2-1 PMI test for single-layer (TDD)

Parameter	Unit	Test 1	
Bandwidth	MHz	10	
Transmission mode		6	
Uplink downlink configuration		1	
Special subframe configuration		4	
Propagation channel		EVA5	
Precoding granularity	PRB	50	
Correlation and antenna configuration		Low 2 x 2	
Downlink power allocation	ρ_A	dB	-3
	ρ_B	dB	-3
	σ	dB	0
$N_{oc}^{(j)}$	dB[mW/15kHz]	-98	
Reporting mode		PUSCH 3-1	
Reporting interval	ms	1	
PMI delay (Note 2)	ms	10 or 11	
Measurement channel		R.10 TDD	
OCNG Pattern		OP.1 TDD	
Max number of HARQ transmissions		4	
Redundancy version coding sequence		{0,1,2,3}	
ACK/NACK feedback mode		Multiplexing	
<p>Note 1: For random precoder selection, the precoder shall be updated in each available downlink transmission instance.</p> <p>Note 2: If the UE reports in an available uplink reporting instance at subframe SF#n based on PMI estimation at a downlink SF not later than SF#(n-4), this reported PMI cannot be applied at the eNB downlink before SF#(n+4).</p>			

Table 9.4.1.1.2-2 Minimum requirement (TDD)

Parameter	Test 1
γ	1.1
UE Category	1-8

9.4.1.2 Minimum requirement PUCCH 2-1 (Cell-Specific Reference Symbols)

9.4.1.2.1 FDD

For the parameters specified in Table 9.4.1.2.1-1, and using the downlink physical channels specified in Annex C.3.2, the minimum requirements are specified in Table 9.4.1.2.1-2.

Table 9.4.1.2.1-1 PMI test for single-layer (FDD)

Parameter		Unit	Test 1
Bandwidth		MHz	10
Transmission mode			6
Propagation channel			EVA5
Correlation and antenna configuration			Low 4 x 2
Downlink power allocation	ρ_A	dB	-6
	ρ_B	dB	-6
	σ	dB	3
$N_{oc}^{(j)}$		dB[mW/15kHz]	-98
PMI delay		ms	8 or 9
Reporting mode			PUCCH 2-1 (Note 6)
Reporting periodicity		ms	$N_{pd} = 2$
Physical channel for CQI reporting			PUSCH (Note 3)
PUCCH Report Type for wideband CQI/PMI			2
PUCCH Report Type for subband CQI			1
Measurement channel			R.14-1 FDD
OCNG Pattern			OP. 1/2 FDD
Precoding granularity		PRB	6 (full size)
Number of bandwidth parts (J)			3
K			1
<i>cqi-pmi-ConfigIndex</i>			1
Max number of HARQ transmissions			4
Redundancy version coding sequence			{0,1,2,3}
<p>Note 1: For random precoder selection, the precoder shall be updated every two TTI (2 ms granularity).</p> <p>Note 2: If the UE reports in an available uplink reporting instance at subframe SF#n based on PMI estimation at a downlink SF not later than SF#(n-4), this reported PMI cannot be applied at the eNB downlink before SF#(n+4).</p> <p>Note 3: To avoid collisions between HARQ-ACK and wideband CQI/PMI or subband CQI, it is necessary to report both on PUSCH instead of PUCCH. PDCCH DCI format 0 shall be transmitted in downlink SF#1, #3, #7 and #9 to allow periodic CQI to multiplex with the HARQ-ACK on PUSCH in uplink subframe SF#5, #7, #1 and #3.</p> <p>Note 4: Reports for the short subband (having 2RBs in the last bandwidth part) are to be disregarded and instead data is to be transmitted on the most recently used subband for bandwidth part with $j=1$.</p> <p>Note 5: In the case where wideband PMI is reported, data is to be transmitted on the most recently used subband.</p> <p>Note 6: The bit field for PMI confirmation in DCI format 1B shall be mapped to "0" and TPMI information shall indicate the codebook index used in Table 6.3.4.2.3-2 of TS36.211 [4] according to the latest PMI report on PUCCH.</p>			

Table 9.4.1.2.1-2 Minimum requirement (FDD)

	Test 1
γ	1.2
UE Category	1-8

9.4.1.2.2 TDD

For the parameters specified in Table 9.4.1.2.2-1, and using the downlink physical channels specified in Annex C.3.2, the minimum requirements are specified in Table 9.4.1.2.2-2.

Table 9.4.1.2.2-1 PMI test for single-layer (TDD)

Parameter		Unit	Test 1
Bandwidth		MHz	10
Transmission mode			6
Uplink downlink configuration			1
Special subframe configuration			4
Propagation channel			EVA5
Correlation and antenna configuration			Low 4 x 2
Downlink power allocation	ρ_A	dB	-6
	ρ_B	dB	-6
	σ	dB	3
$N_{oc}^{(j)}$		dB[mW/15kHz]	-98
PMI delay		ms	10
Reporting mode			PUCCH 2-1 (Note 6)
Reporting periodicity		ms	$N_P = 5$
Physical channel for CQI reporting			PUSCH (Note 3)
PUCCH Report Type for wideband CQI/PMI			2
PUCCH Report Type for subband CQI			1
Measurement channel			R.14-1 TDD
OCNG Pattern			OP.1/2 TDD
Precoding granularity		PRB	6 (full size)
Number of bandwidth parts (J)			3
K			1
<i>cqi-pmi-ConfigIndex</i>			4
Max number of HARQ transmissions			4
Redundancy version coding sequence			{0,1,2,3}
ACK/NACK feedback mode			Multiplexing
<p>Note 1: For random precoder selection, the precoder shall be updated in each available downlink transmission instance.</p> <p>Note 2: If the UE reports in an available uplink reporting instance at subframe SF#n based on PMI estimation at a downlink SF not later than SF#(n-4), this reported PMI cannot be applied at the eNB downlink before SF#(n+4).</p> <p>Note 3: To avoid collisions between HARQ-ACK and wideband CQI/PMI or subband CQI it is necessary to report both on PUSCH instead of PUCCH. PDCCH DCI format 0 shall be transmitted in downlink SF#4 and #9 to allow periodic CQI to multiplex with the HARQ-ACK on PUSCH in uplink subframe SF#8 and #3.</p> <p>Note 4: Reports for the short subband (having 2RBs in the last bandwidth part) are to be disregarded and instead data is to be transmitted on the most recently used subband for bandwidth part with $j=1$.</p> <p>Note 5: In the case where wideband PMI is reported, data is to be transmitted on the most recently used subband.</p> <p>Note 6: The bit field for PMI confirmation in DCI format 1B shall be mapped to "0" and TPMI information shall indicate the codebook index used in Table 6.3.4.2.3-2 of TS36.211 [4] according to the latest PMI report on PUCCH.</p>			

Table 9.4.1.2.2-2 Minimum requirement (TDD)

	Test 1
γ	1.2
UE Category	1-8

9.4.1.3 Minimum requirement PUSCH 3-1 (CSI Reference Symbol)

9.4.1.3.1 FDD

For the parameters specified in Table 9.4.1.3.1-1, and using the downlink physical channels specified in Annex C.3.2, the minimum requirements are specified in Table 9.4.1.3.1-2.

Table 9.4.1.3.1-1 PMI test for single-layer (FDD)

Parameter	Unit	Test 1	
Bandwidth	MHz	10	
Transmission mode		9	
Propagation channel		EPA5	
Precoding granularity	PRB	50	
Correlation and antenna configuration		Low ULA 4 x 2	
Cell-specific reference signals		Antenna ports 0,1	
CSI reference signals		Antenna ports 15,...,18	
Beamforming model		Annex B.4.3	
CSI-RS periodicity and subframe offset $T_{\text{CSI-RS}} / \Delta_{\text{CSI-RS}}$		5/ 1	
CSI-RS reference signal configuration		6	
CodeBookSubsetRestriction bitmap		0x0000 0000 0000 FFFF	
Downlink power allocation	ρ_A	dB	0
	ρ_B	dB	0
	P_c	dB	-3
	σ	dB	-3
$N_{oc}^{(j)}$	dB[mW/15kHz]	-98	
Reporting mode		PUSCH 3-1	
Reporting interval	ms	5	
PMI delay (Note 2)	ms	8	
Measurement channel		R.44 FDD	
OCNG Pattern		OP.1 FDD	
Max number of HARQ transmissions		4	
Redundancy version coding sequence		{0,1,2,3}	
<p>Note 1: For random precoder selection, the precoder shall be updated in each TTI (1 ms granularity).</p> <p>Note 2: If the UE reports in an available uplink reporting instance at subframe SF#n based on PMI estimation at a downlink SF not later than SF#(n-4), this reported PMI cannot be applied at the eNB downlink before SF#(n+4).</p> <p>Note 3: PDSCH_RA= 0 dB, PDSCH_RB= 0 dB in order to have the same PDSCH and OCNG power per subcarrier at the receiver.</p>			

Table 9.4.1.3.1-2 Minimum requirement (FDD)

Parameter	Test 1
γ	1-2
UE Category	1-8

9.4.1.3.2 TDD

For the parameters specified in Table 9.4.1.3.2-1, and using the downlink physical channels specified in Annex C.3.2, the minimum requirements are specified in Table 9.4.1.3.2-2.

Table 9.4.1.3.2-1 PMI test for single-layer (TDD)

Parameter	Unit	Test 1	
Bandwidth	MHz	10	
Transmission mode		9	
Uplink downlink configuration		1	
Special subframe configuration		4	
Propagation channel		EVA5	
Precoding granularity	PRB	50	
Antenna configuration		8 x 2	
Correlation modeling		High, Cross polarized	
Cell-specific reference signals		Antenna ports 0,1	
CSI reference signals		Antenna ports 15,...,22	
Beamforming model		Annex B.4.3	
CSI-RS periodicity and subframe offset $T_{\text{CSI-RS}} / \Delta_{\text{CSI-RS}}$		5/ 4	
CSI-RS reference signal configuration		0	
CodeBookSubsetRestriction bitmap		0x0000 0000 001F FFE0 0000 0000 FFFF	
Downlink power allocation	ρ_A	dB	0
	ρ_B	dB	0
	P_c	dB	-6
	σ	dB	-3
$N_{oc}^{(j)}$	dB[mW/15kHz]	-98	
Reporting mode		PUSCH 3-1	
Reporting interval	ms	5	
PMI delay (Note 2)	ms	10	
Measurement channel		R.45-1 TDD for UE Category 1, R.45 TDD for UE Category 2-8	
OCNG Pattern		OP.7 TDD for UE Category 1, OP.1 TDD for UE Category 2-8	
Max number of HARQ transmissions		4	
Redundancy version coding sequence		{0,1,2,3}	
ACK/NACK feedback mode		Multiplexing	
Note 1:	For random precoder selection, the precoder shall be updated in each TTI (1 ms granularity).		
Note 2:	If the UE reports in an available uplink reporting instance at subframe SF#n based on PMI estimation at a downlink SF not later than SF#(n-4), this reported PMI cannot be applied at the eNB downlink before SF#(n+4).		
Note 3:	PDCCH DCI format 0 with a trigger for aperiodic CQI shall be transmitted in downlink SF#4 and #9 to allow aperiodic CQI/PMI/RI to be transmitted on uplink SF#3 and #8.		

Note 4: Randomization of the principle beam direction shall be used as specified in B.2.3A.4
--

Table 9.4.1.3.2-2 Minimum requirement (TDD)

Parameter	Test 1
γ	3
UE Category	1-8

9.4.1a Void

9.4.1a.1 Void

9.4.1a.1.1 Void

9.4.1a.1.2 Void

9.4.2 Multiple PMI

9.4.2.1 Minimum requirement PUSCH 1-2 (Cell-Specific Reference Symbols)

9.4.2.1.1 FDD

For the parameters specified in Table 9.4.2.1.1-1, and using the downlink physical channels specified in Annex C.3.2, the minimum requirements are specified in 9.4.2.1.1-2.

Table 9.4.2.1.1-1 PMI test for single-layer (FDD)

Parameter		Unit	Test 1
Bandwidth		MHz	10
Transmission mode			6
Propagation channel			EPA5
Precoding granularity (only for reporting and following PMI)		PRB	6
Correlation and antenna configuration			Low 2 x 2
Downlink power allocation	ρ_A	dB	-3
	ρ_B	dB	-3
	σ	dB	0
$N_{oc}^{(j)}$		dB[mW/15kHz]	-98
Reporting mode			PUSCH 1-2
Reporting interval		ms	1
PMI delay		ms	8
Measurement channel			R.11-3 FDD for UE Category 1, R.11 FDD for UE Category 2-8
OCNG Pattern			OP.1/2 FDD
Max number of HARQ transmissions			4
Redundancy version coding sequence			{0,1,2,3}
<p>Note 1: For random precoder selection, the precoders shall be updated in each TTI (1 ms granularity).</p> <p>Note 2: If the UE reports in an available uplink reporting instance at subframe SF#n based on PMI estimation at a downlink SF not later than SF#(n-4), this reported PMI cannot be applied at the eNB downlink before SF#(n+4).</p> <p>Note 3: One/two sided dynamic OCNG Pattern OP.1/2 FDD as described in Annex A.5.1.1/2 shall be used.</p>			

Table 9.4.2.1.1-2 Minimum requirement (FDD)

Parameter	Test 1
γ	1.2
UE Category	1-8

9.4.2.1.2 TDD

For the parameters specified in Table 9.4.2.1.2-1, and using the downlink physical channels specified in Annex C.3.2, the minimum requirements are specified in 9.4.2.1.2-2.

Table 9.4.2.1.2-1 PMI test for single-layer (TDD)

Parameter		Unit	Test 1
Bandwidth		MHz	10
Transmission mode			6
Uplink downlink configuration			1
Special subframe configuration			4
Propagation channel			EPA5
Precoding granularity (only for reporting and following PMI)		PRB	6
Correlation and antenna configuration			Low 2 x 2
Downlink power allocation	ρ_A	dB	-3
	ρ_B	dB	-3
	σ	dB	0
$N_{oc}^{(j)}$		dB[mW/15kHz]	-98
Reporting mode			PUSCH 1-2
Reporting interval		ms	1
PMI delay		ms	10 or 11
Measurement channel			R.11-3 TDD for UE Category 1 R.11 TDD for UE Category 2-8
OCNG Pattern			OP.1/2 TDD
Max number of HARQ transmissions			4
Redundancy version coding sequence			{0,1,2,3}
ACK/NACK feedback mode			Multiplexing
<p>Note 1: For random precoder selection, the precoders shall be updated in each available downlink transmission instance.</p> <p>Note 2: If the UE reports in an available uplink reporting instance at subframe SF#n based on PMI estimation at a downlink SF not later than SF#(n-4), this reported PMI cannot be applied at the eNB downlink before SF#(n+4).</p> <p>Note 3: One/two sided dynamic OCNG Pattern OP.1/2 TDD as described in Annex A.5.2.1/2 shall be used.</p>			

Table 9.4.2.1.2-2 Minimum requirement (TDD)

Parameter	Test 1
γ	1.2
UE Category	1-8

9.4.2.2 Minimum requirement PUSCH 2-2 (Cell-Specific Reference Symbols)

9.4.2.2.1 FDD

For the parameters specified in Table 9.4.2.2.1-1, and using the downlink physical channels specified in Annex C.3.2, the minimum requirements are specified in Table 9.4.2.2.1-2.

Table 9.4.2.2.1-1 PMI test for single-layer (FDD)

Parameter		Unit	Test 1
Bandwidth		MHz	10
Transmission mode			6
Propagation channel			EVA5
Correlation and antenna configuration			Low 4 x 2
Downlink power allocation	ρ_A	dB	-6
	ρ_B	dB	-6
	σ	dB	3
$N_{oc}^{(j)}$		dB[mW/15kHz]	-98
PMI delay		ms	8
Reporting mode			PUSCH 2-2
Reporting interval		ms	1
Measurement channel			R.14-2 FDD
OCNG Pattern			OP. 1/2 FDD
Subband size (k)		RBs	3 (full size)
Number of preferred subbands (M)			5
Max number of HARQ transmissions			4
Redundancy version coding sequence			{0,1,2,3}
Note 1: For random precoder selection, the precoder shall be updated in each TTI (1 ms granularity)			
Note 2: If the UE reports in an available uplink reporting instance at subframe SF#n based on PMI estimation at a downlink SF not later than SF#(n-4), this reported PMI cannot be applied at the eNB downlink before SF#(n+4)			

Table 9.4.2.2.1-2 Minimum requirement (FDD)

	Test 1
γ	1.2
UE Category	1-8

9.4.2.2.2 TDD

For the parameters specified in Table 9.4.2.2.2-1, and using the downlink physical channels specified in Annex C.3.2, the minimum requirements are specified in Table 9.4.2.2.2-2.

Table 9.4.2.2.2-1 PMI test for single-layer (TDD)

Parameter		Unit	Test 1
Bandwidth		MHz	10
Transmission mode			6
Uplink downlink configuration			1
Special subframe configuration			4

Propagation channel			EVA5
Correlation and antenna configuration			Low 4 x 2
Downlink power allocation	ρ_A	dB	-6
	ρ_B	dB	-6
	σ	dB	3
$N_{oc}^{(j)}$		dB[mW/15kHz]	-98
PMI delay		ms	10
Reporting mode			PUSCH 2-2
Reporting interval		ms	1
Measurement channel			R.14-2 TDD
OCNG Pattern			OP.1/2 TDD
Subband size (k)		RBs	3 (full size)
Number of preferred subbands (M)			5
Max number of HARQ transmissions			4
Redundancy version coding sequence			{0,1,2,3}
ACK/NACK feedback mode			Multiplexing
<p>Note 1: For random precoder selection, the precoders shall be updated in each available downlink transmission instance.</p> <p>Note 2: If the UE reports in an available uplink reporting instance at subframe SF#n based on PMI estimation at a downlink SF not later than SF#(n-4), this reported PMI cannot be applied at the eNB downlink before SF#(n+4).</p>			

Table 9.4.2.2-2 Minimum requirement (TDD)

	Test 1
γ	1.15
UE Category	1-8

9.4.2.3 Minimum requirement PUSCH 1-2 (CSI Reference Symbol)

9.4.2.3.1 FDD

For the parameters specified in Table 9.4.2.3.1-1, and using the downlink physical channels specified in Annex C.3.2, the minimum requirements are specified in 9.4.2.3.1-2.

Table 9.4.2.3.1-1 PMI test for single-layer (FDD)

Parameter		Unit	Test 1
Bandwidth		MHz	10
Transmission mode			9
Propagation channel			EVA5
Precoding granularity (only for reporting and following PMI)		PRB	6
Correlation and antenna configuration			Low ULA 4 x 2
Cell-specific reference signals			Antenna ports 0,1
CSI reference signals			Antenna ports 15,...,18
Beamforming model			Annex B.4.3
CSI-RS periodicity and subframe offset $T_{\text{CSI-RS}} / \Delta_{\text{CSI-RS}}$			5/ 1
CSI-RS reference signal configuration			8
CodeBookSubsetRestriction restriction bitmap			0x0000 0000 0000 FFFF
Downlink power allocation	ρ_A	dB	0
	ρ_B	dB	0
	Pc	dB	-3
	σ	dB	-3
$N_{oc}^{(j)}$		dB[mW/15kHz]	-98
Reporting mode			PUSCH 1-2
Reporting interval		ms	5
PMI delay		ms	8
Measurement channel			R.45-1 FDD for UE Category 1, R.45 FDD for UE Category 2-8
OCNG Pattern			OP.7 FDD for UE Category 1 OP.1 FDD for UE Category 2-8
Max number of HARQ transmissions			4
Redundancy version coding sequence			{0,1,2,3}
<p>Note 1: For random precoder selection, the precoders shall be updated in each TTI (1 ms granularity).</p> <p>Note 2: If the UE reports in an available uplink reporting instance at subframe SF#n based on PMI estimation at a downlink SF not later than SF#(n-4), this reported PMI cannot be applied at the eNB downlink before SF#(n+4).</p> <p>Note 3: Void.</p> <p>Note 4: PDSCH_RA= 0 dB, PDSCH_RB= 0 dB in order to have the same PDSCH and OCNG power per subcarrier at the receiver.</p>			

Table 9.4.2.3.1-2 Minimum requirement (FDD)

Parameter	Test 1
γ	1.3
UE Category	1-8

9.4.2.3.2 TDD

For the parameters specified in Table 9.4.2.3.2-1, and using the downlink physical channels specified in Annex C.3.2, the minimum requirements are specified in 9.4.2.3.2-2.

Table 9.4.2.3.2-1 PMI test for single-layer (TDD)

Parameter	Unit	Test 1	
Bandwidth	MHz	10	
Transmission mode		9	
Uplink downlink configuration		1	
Special subframe configuration		4	
Propagation channel		EVA5	
Precoding granularity (only for reporting and following PMI)	PRB	6	
Antenna configuration		8 x 2	
Correlation modeling		High, Cross polarized	
Cell-specific reference signals		Antenna ports 0,1	
CSI reference signals		Antenna ports 15,...,22	
Beamforming model		Annex B.4.3	
CSI-RS periodicity and subframe offset $T_{\text{CSI-RS}} / \Delta_{\text{CSI-RS}}$		5/ 4	
CSI-RS reference signal configuration		4	
CodeBookSubsetRestriction bitmap		0x0000 0000 001F FFE0 0000 0000 FFFF	
Downlink power allocation	ρ_A	dB	0
	ρ_B	dB	0
	Pc	db	-6
	σ	dB	-3
$N_{oc}^{(j)}$	dB[mW/15kHz]	-98	
Reporting mode		PUSCH 1-2	
Reporting interval	ms	5 (Note 4)	
PMI delay	ms	10	
Measurement channel		R.45-1 TDD for UE Category 1, R.45 TDD for UE Category 2-8	
OCNG Pattern		OP.7 TDD for UE Category 1 OP.1 TDD for UE Category 2-8	
Max number of HARQ transmissions		4	
Redundancy version coding sequence		{0,1,2,3}	
ACK/NACK feedback mode		Multiplexing	
<p>Note 1: For random precoder selection, the precoders shall be updated in each TTI (1 ms granularity).</p> <p>Note 2: If the UE reports in an available uplink reporting instance at subframe SF#n based on PMI estimation at a downlink SF not later than SF#(n-4), this reported PMI cannot be applied at the eNB downlink before SF#(n+4).</p> <p>Note 3: Void.</p> <p>Note 4: PDCCH DCI format 0 with a trigger for aperiodic</p>			

<p>CQI shall be transmitted in downlink SF#4 and #9 to allow aperiodic CQI/PMI/RI to be transmitted on uplink SF#3 and #8.</p> <p>Note 5: Randomization of the principle beam direction shall be used as specified in B.2.3A.4.</p>

Table 9.4.2.3.2-2 Minimum requirement (TDD)

Parameter	Test 1
γ	3.5
UE Category	1-8

9.4.3 Void

9.4.3.1 Void

9.4.3.1.1 Void

9.4.3.1.2 Void

9.5 Reporting of Rank Indicator (RI)

The purpose of this test is to verify that the reported rank indicator accurately represents the channel rank. The accuracy of RI (CQI) reporting is determined by the relative increase of the throughput obtained when transmitting based on the reported rank compared to the case for which a fixed rank is used for transmission. Transmission mode 4 is used with the specified CodebookSubSetRestriction in section 9.5.1, transmission mode 9 is used with the specified CodebookSubSetRestriction in section 9.5.2 and transmission mode 3 is used with the specified CodebookSubSetRestriction in section 9.5.3.

For fixed rank 1 transmission in sections 9.5.1 and 9.5.2, the RI and PMI reporting is restricted to two single-layer precoders, For fixed rank 2 transmission in sections 9.5.1 and 9.5.2, the RI and PMI reporting is restricted to one two-layer precoder, For follow RI transmission in sections 9.5.1 and 9.5.2, the RI and PMI reporting is restricted to select the union of these precoders. Channels with low and high correlation are used to ensure that RI reporting reflects the channel condition.

For fixed rank 1 transmission in section 9.5.3, the RI reporting is restricted to single-layer, for fixed rank 2 transmission in section 9.5.3, the RI reporting is restricted to two-layers. For follow RI transmission in section 9.5.3, the RI reporting is either one or two layers.

9.5.1 Minimum requirement (Cell-Specific Reference Symbols)

9.5.1.1 FDD

The minimum performance requirement in Table 9.5.1.1-2 is defined as

- a) The ratio of the throughput obtained when transmitting based on UE reported RI and that obtained when transmitting with fixed rank 1 shall be $\geq \gamma_1$;
- b) The ratio of the throughput obtained when transmitting based on UE reported RI and that obtained when transmitting with fixed rank 2 shall be $\geq \gamma_2$;

For the parameters specified in Table 9.5.1.1-1, and using the downlink physical channels specified in Annex C.3.2, the minimum requirements are specified in Table 9.5.1.1-2.

Table 9.5.1.1-1 RI Test (FDD)

Parameter	Unit	Test 1	Test 2	Test 3	
Bandwidth	MHz			10	
PDSCH transmission mode				4	
Downlink power allocation	ρ_A	dB		-3	
	ρ_B	dB		-3	
	σ	dB		0	
Propagation condition and antenna configuration		2 x 2 EPA5			
CodeBookSubsetRestriction bitmap		000011 for fixed RI = 1 010000 for fixed RI = 2 010011 for UE reported RI			
Antenna correlation		Low	Low	High	
RI configuration		Fixed RI=2 and follow RI	Fixed RI=1 and follow RI	Fixed RI=1 and follow RI	Fixed RI=2 and follow RI
SNR	dB	0	20	20	20
$N_{oc}^{(j)}$	dB[mW/15kHz]	-98	-98	-98	-98
$\hat{I}_{or}^{(j)}$	dB[mW/15kHz]	-98	-78	-78	-78
Maximum number of HARQ transmissions		1			
Reporting mode		PUCCH 1-1 (Note 4)			
Physical channel for CQI/PMI reporting		PUCCH Format 2			
PUCCH Report Type for CQI/PMI		2			
Physical channel for RI reporting		PUSCH (Note 3)			
PUCCH Report Type for RI		3			
Reporting periodicity	ms	$N_{pd}= 5$			
PMI and CQI delay	ms	8			
<i>cqi-pmi-ConfigurationIndex</i>		6			
<i>ri-ConfigurationInd</i>		1 (Note 5)			
Note 1:	If the UE reports in an available uplink reporting instance at subframe SF#n based on PMI and CQI estimation at a downlink subframe not later than SF#(n-4), this reported PMI and wideband CQI cannot be applied at the eNB downlink before SF#(n+4).				
Note 2:	Reference measurement channel RC.2 FDD according to Table A.4-1 with one sided dynamic OCNB Pattern OP.1 FDD as described in Annex A.5.1.1.				
Note 3:	To avoid collisions between RI reports and HARQ-ACK it is necessary to report both on PUSCH instead of PUCCH. PDCCH DCI format 0 shall be transmitted in downlink SF#4 and #9 to allow periodic RI to multiplex with the HARQ-ACK on PUSCH in uplink subframe SF#8 and #3.				
Note 4:	The bit field for precoding information in DCI format 2 shall be mapped as: <ul style="list-style-type: none"> • For reported RI = 1 and PMI = 0 >> precoding information bit field index = 1 • For reported RI = 1 and PMI = 1 >> precoding information bit field index = 2 • For reported RI = 2 and PMI = 0 >> precoding information bit field index = 0 				
Note 5:	To avoid the ambiguity of TE behaviour when applying CQI and PMI during rank switching, RI reports are to be applied at the TE with one subframe delay in addition to Note 1 to align with CQI and PMI reports.				

Table 9.5.1.1-2 Minimum requirement (FDD)

	Test 1	Test 2	Test 3
γ_1	N/A	1.05	0.9 (Note 1)
γ_2	1	N/A	1.1 (Note 1)
UE Category	2-8	2-8	2-8
Note 1:	For Test 3, the minimum requirements shall be fulfilled for at least one of γ_1 or γ_2 .		

9.5.1.2 TDD

The minimum performance requirement in Table 9.5.1.2-2 is defined as

- a) The ratio of the throughput obtained when transmitting based on UE reported RI and that obtained when transmitting with fixed rank 1 shall be $\geq \gamma_1$;
- b) The ratio of the throughput obtained when transmitting based on UE reported RI and that obtained when transmitting with fixed rank 2 shall be $\geq \gamma_2$;

For the parameters specified in Table 9.5.1.2-1, and using the downlink physical channels specified in Annex C.3.2, the minimum requirements are specified in Table 9.5.1.2-2.

Table 9.5.1.2-1 RI Test (TDD)

Parameter	Unit	Test 1	Test 2	Test 3	
Bandwidth	MHz	10			
PDSCH transmission mode		4			
Downlink power allocation	ρ_A	dB	-3		
	ρ_B	dB	-3		
	σ	dB	0		
Uplink downlink configuration		2			
Special subframe configuration		4			
Propagation condition and antenna configuration		2 x 2 EPA5			
CodeBookSubsetRestriction bitmap		000011 for fixed RI = 1 010000 for fixed RI = 2 010011 for UE reported RI			
Antenna correlation		Low	Low	High	
RI configuration		Fixed RI=2 and follow RI	Fixed RI=1 and follow RI	Fixed RI=1 and follow RI	Fixed RI=2 and follow RI
SNR	dB	0	20	20	20
$N_{oc}^{(j)}$	dB[mW/15kHz]	-98	-98	-98	-98
$\hat{I}_{or}^{(j)}$	dB[mW/15kHz]	-98	-78	-78	-78
Maximum number of HARQ transmissions		1			
Reporting mode		PUSCH 3-1 (Note 3)			
Reporting interval	ms	5			
PMI and CQI delay	ms	10 or 11			
ACK/NACK feedback mode		Bundling			
Note 1: If the UE reports in an available uplink reporting instance at subframe SF#n based on PMI and CQI estimation at a downlink subframe not later than SF#(n-4), this reported PMI and wideband CQI cannot be applied at the eNB downlink before SF#(n+4).					
Note 2: Reference measurement channel RC.2 TDD according to Table A.4-1 with one sided dynamic OCNG Pattern OP.1 TDD as described in Annex A.5.2.1.					
Note 3: Reported wideband CQI and PMI are used and sub-band CQI is discarded.					

Table 9.5.1.2-2 Minimum requirement (TDD)

	Test 1	Test 2	Test 3
γ_1	N/A	1.05	0.9 (Note 1)
γ_2	1	N/A	1.1 (Note 1)
UE Category	2-8	2-8	2-8
Note 1: For Test 3, the minimum requirements shall be fulfilled for at least one of γ_1 or γ_2 .			

9.5.2 Minimum requirement (CSI Reference Symbols)

9.5.2.1 FDD

The minimum performance requirement in Table 9.5.2.1-2 is defined as

- a) The ratio of the throughput obtained when transmitting based on UE reported RI and that obtained when transmitting with fixed rank 1 shall be $\geq \gamma_1$;
- b) The ratio of the throughput obtained when transmitting based on UE reported RI and that obtained when transmitting with fixed rank 2 shall be $\geq \gamma_2$;

For the parameters specified in Table 9.5.2.1-1, and using the downlink physical channels specified in Annex C.3.2, the minimum requirements are specified in Table 9.5.2.1-2.

Table 9.5.2.1-1 RI Test (FDD)

Parameter		Unit	Test 1	Test 2	Test 3
Bandwidth		MHz		10	
PDSCH transmission mode				9	
Downlink power allocation	ρ_A	dB		0	
	ρ_B	dB		0	
	P_c	dB		0	
	σ	dB		0	
Propagation condition and antenna configuration			2 x 2 EPA5		
Cell-specific reference signals			Antenna ports 0		
CSI reference signals			Antenna ports 15, 16		
Beamforming Model			As specified in Section B.4.3		
CSI-RS periodicity and subframe offset $T_{\text{CSI-RS}} / \Delta_{\text{CSI-RS}}$			5/1		
CSI reference signal configuration			6		
CodeBookSubsetRestriction bitmap			000011 for fixed RI = 1 010000 for fixed RI = 2 010011 for UE reported RI		
Antenna correlation			Low	Low	High
RI configuration			Fixed RI=2 and follow RI	Fixed RI=1 and follow RI	Fixed RI=1 and follow RI
SNR		dB	0	20	20
$N_{oc}^{(j)}$		dB[mW/15kHz]	-98	-98	-98
$\hat{I}_{or}^{(j)}$		dB[mW/15kHz]	-98	-78	-78
Maximum number of HARQ transmissions			1		
Reporting mode			PUCCH 1-1		
Physical channel for CQI/PMI reporting			PUSCH (Note 3)		
PUCCH Report Type for CQI/PMI			2		
Physical channel for RI reporting			PUCCH Format 2		
PUCCH Report Type for RI			3		
Reporting periodicity		ms	$N_{pd} = 5$		
PMI and CQI delay		ms	8		
<i>cqi-pmi-ConfigurationIndex</i>			2		
<i>ri-ConfigurationInd</i>			1 (Note 4)		
<p>Note 1: If the UE reports in an available uplink reporting instance at subframe SF#n based on PMI and CQI estimation at a downlink subframe not later than SF#(n-4), this reported PMI and wideband CQI cannot be applied at the eNB downlink before SF#(n+4).</p> <p>Note 2: Reference measurement channel RC.9 FDD according to Table A.4-1 with one sided dynamic OCNG Pattern OP.1 FDD as described in Annex A.5.1.1.</p> <p>Note 3: To avoid collisions between CQI/ PMI reports and HARQ-ACK it is necessary to report both on PUSCH instead of PUCCH. PDCCH DCI format 0 shall be transmitted in downlink SF#1 and #6 to allow periodic CQI/ PMI to multiplex with the HARQ-ACK on PUSCH in uplink SF#0 and #5.</p> <p>Note 4: To avoid the ambiguity of TE behaviour when applying CQI and PMI during rank switching, RI reports are to be applied at the TE with one subframe delay in addition to Note 1 to align with CQI and PMI reports.</p>					

Table 9.5.2.1-2 Minimum requirement (FDD)

	Test 1	Test 2	Test 3
γ_1	N/A	1.05	0.9
γ_2	1	N/A	N/A
UE Category	2-8	2-8	2-8

9.5.2.2 TDD

The minimum performance requirement in Table 9.5.2.2-2 is defined as

- a) The ratio of the throughput obtained when transmitting based on UE reported RI and that obtained when transmitting with fixed rank 1 shall be $\geq \gamma_1$;
- b) The ratio of the throughput obtained when transmitting based on UE reported RI and that obtained when transmitting with fixed rank 2 shall be $\geq \gamma_2$;

For the parameters specified in Table 9.5.2.2-1, and using the downlink physical channels specified in Annex C.3.2, the minimum requirements are specified in Table 9.5.2.2-2.

Table 9.5.2.2-1 RI Test (TDD)

Parameter	Unit	Test 1	Test 2	Test 3
Bandwidth	MHz		10	
PDSCH transmission mode			9	
Downlink power allocation	ρ_A	dB	0	
	ρ_B	dB	0	
	P_c	dB	0	
	σ	dB	0	
Uplink downlink configuration			1	
Special subframe configuration			4	
Propagation condition and antenna configuration			2 x 2 EPA5	
Cell-specific reference signals			Antenna ports 0	
CSI reference signals			Antenna ports 15, 16	
Beamforming Model			As specified in Section B.4.3	
CSI reference signal configuration			4	
CSI-RS periodicity and subframe offset $T_{\text{CSI-RS}} / \Delta_{\text{CSI-RS}}$			5/4	
CodeBookSubsetRestriction bitmap			000011 for fixed RI = 1 010000 for fixed RI = 2 010011 for UE reported RI	
Antenna correlation		Low	Low	High
RI configuration		Fixed RI=2 and follow RI	Fixed RI=1 and follow RI	Fixed RI=1 and follow RI
SNR	dB	0	20	20
$N_{oc}^{(j)}$	dB[mW/15kHz]	-98	-98	-98
$\hat{I}_{or}^{(j)}$	dB[mW/15kHz]	-98	-78	-78
Maximum number of HARQ transmissions		1		
Reporting mode		PUCCH 1-1		
Physical channel for CQI/ PMI reporting		PUSCH (Note 3)		
PUCCH report type for CQI/ PMI		2		
Physical channel for RI reporting		PUCCH Format 2		
Reporting periodicity	ms	$N_{pd} = 5$		
PMI and CQI delay	ms	10		
ACK/NACK feedback mode		Bundling		
<i>cqi-pmi-ConfigurationIndex</i>		4		
<i>ri-ConfigurationInd</i>		1		
Note 1:	If the UE reports in an available uplink reporting instance at subframe SF#n based on PMI and CQI estimation at a downlink subframe not later than SF#(n-4), this reported PMI and wideband CQI cannot be applied at the eNB downlink before SF#(n+4).			
Note 2:	Reference measurement channel RC.9 TDD according to Table A.4-1 with one sided dynamic OCNG Pattern OP.1 TDD as described in Annex A.5.2.1.			
Note 3:	To avoid collisions between CQI/PMI reports and HARQ-ACK it is necessary to report both on PUSCH instead of PUCCH. PDCCH DCI format 0 shall be transmitted in downlink SF#4 and #9 to allow periodic CQI/PMI to multiplex with the HARQ-ACK on PUSCH in uplink SF#3 and #8.			

Table 9.5.2.2-2 Minimum requirement (TDD)

	Test 1	Test 2	Test 3
γ_1	N/A	1.05	0.9
γ_2	1	N/A	N/A
UE Category	2-8	2-8	2-8

9.5.3 Minimum requirement (CSI measurements in case two CSI subframe sets are configured)

9.5.3.1 FDD

The minimum performance requirement in Table 9.5.3.1-2 is defined as

- a) The ratio of the throughput obtained when transmitting based on UE reported RI and that obtained when transmitting with fixed rank 1 shall be $\geq \gamma_1$

For the parameters specified in Table 9.5.3.1-1, and using the downlink physical channels specified in Annex C.3.2, the minimum requirements are specified in Table 9.5.3.1-2.

Table 9.5.3.1-1 RI Test (FDD)

Parameter		Unit	Test 1		Test 2	
			Cell 1	Cell 2	Cell 1	Cell 2
Bandwidth		MHz	10		10	
PDSCH transmission mode			3	Note 10	3	Note 10
Downlink power allocation	ρ_A	dB	-3		-3	
	ρ_B	dB	-3		-3	
	σ	dB	0		0	
Propagation condition and antenna configuration			2 x 2 EPA5		2 x 2 EPA5	
CodeBookSubsetRestriction bitmap			01 for fixed RI = 1 10 for fixed RI = 2 11 for UE reported RI	N/A	01 for fixed RI = 1 10 for fixed RI = 2 11 for UE reported RI	N/A
Antenna correlation			Low		Low	
RI configuration			Fixed RI=1 and follow RI	N/A	Fixed RI=1 and follow RI	N/A
\widehat{E}_s / N_{oc2}		dB	0	-12	20	6
$N_{oc}^{(j)}$	$N_{oc1}^{(j)}$	dBmW/1 5kHz	-98 (Note 3)	N/A	-102 (Note 3)	N/A
	$N_{oc2}^{(j)}$		-98 (Note 4)	N/A	-98 (Note 4)	N/A
	$N_{oc3}^{(j)}$		-98 (Note 5)	N/A	-94.8 (Note 5)	N/A
$\widehat{I}_{or}^{(j)}$		dB[mW/1 5kHz]	-98	-110	-78	-92
Subframe Configuration			Non-MBSFN	Non-MBSFN	Non-MBSFN	Non-MBSFN
Cell Id			0	1	0	1
Time Offset between Cells		μ s	2.5 (synchronous cells)		2.5 (synchronous cells)	
ABS Pattern (Note 6)			N/A	10000000 10000000 10000000 10000000 10000000	N/A	10000000 10000000 10000000 10000000 10000000
RLM/RRM Measurement Subframe Pattern (Note 7)			10000000 10000000 10000000 10000000	N/A	10000000 10000000 10000000 10000000	N/A
CSI Subframe Sets (Note 8)	C _{CSI,0}		10000000 10000000 10000000 10000000 10000000	N/A	10000000 10000000 10000000 10000000 10000000	N/A
	C _{CSI,1}		01111111 01111111 01111111 01111111 01111111		01111111 01111111 01111111 01111111 01111111	
Number of control OFDM Symbols			3	3	3	3
Maximum number of HARQ transmissions			1		1	
Reporting mode			PUCCH 1-0		PUCCH 1-0	
Physical channel for CQI reporting			PUCCH Format 2		PUCCH Format 2	
PUCCH Report Type for CQI			4		4	
Physical channel for RI reporting			PUCCH Format 2		PUCCH Format 2	
PUCCH Report Type for RI			3		3	

Reporting periodicity	ms	$N_{pd}= 10$		$N_{pd}= 10$	
<i>cqi-pmi-ConfigurationIndex</i>		11		11	
<i>ri-ConfigurationInd</i>		5		5	
<i>cqi-pmi-ConfigurationIndex2</i>		10		10	
<i>ri-ConfigurationInd2</i>		2		2	
Cyclic prefix		Normal	Normal	Normal	Normal
Note 1:	If the UE reports in an available uplink reporting instance at subframe SF#n based on CQI estimation at a downlink subframe not later than SF#(n-4), this reported wideband CQI cannot be applied at the eNB downlink before SF#(n+4).				
Note 2:	Reference measurement channel RC.2 FDD in Cell 1 according to Table A.4-1 with one sided dynamic OCNG Pattern OP.1 FDD as described in Annex A.5.1.1.				
Note 3:	This noise is applied in OFDM symbols #1, #2, #3, #5, #6, #8, #9, #10,#12, #13 of a subframe overlapping with the aggressor ABS.				
Note 4:	This noise is applied in OFDM symbols #0, #4, #7, #11 of a subframe overlapping with the aggressor ABS.				
Note 5:	This noise is applied in all OFDM symbols of a subframe overlapping with aggressor non-ABS				
Note 6:	ABS pattern as defined in [9]. PDSCH other than SIB1/paging and its associated PDCCH/PCFICH are transmitted in the serving cell subframe when the subframe is overlapped with the ABS subframe of aggressor cell and the subframe is available in the definition of the reference channel.				
Note 7:	Time-domain measurement resource restriction pattern for PCell measurements as defined in [7].				
Note 8:	As configured according to the time-domain measurement resource restriction pattern for CSI measurements defined in [7].				
Note 9:	Cell 1 is the serving cell. Cell 2 is the aggressor cell. The number of the CRS ports in Cell 1 and Cell 2 is the same.				
Note 10:	Downlink physical channel setup in Cell 2 in accordance with Annex C.3.3 applying OCNG pattern as defined in Annex A.5.1.5.				

Table 9.5.3.1-2 Minimum requirement (FDD)

	Test 1	Test 2
γ	0.9	1.05
UE Category	2-8	2-8

9.5.3.2 TDD

The minimum performance requirement in Table 9.5.3.2-2 is defined as

- a) The ratio of the throughput obtained when transmitting based on UE reported RI and that obtained when transmitting with fixed rank 1 shall be $\geq \gamma_1$.

For the parameters specified in Table 9.5.3.2-1, and using the downlink physical channels specified in Annex C.3.2, the minimum requirements are specified in Table 9.5.3.2-2.

Table 9.5.3.2-1 RI Test (TDD)

Parameter		Unit	Test1		Test 2	
			Cell 1	Cell 2	Cell 1	Cell 2
Bandwidth		MHz	10		10	
PDSCH transmission mode			3	Note 11	3	Note 11
Uplink downlink configuration			1		1	
Special subframe configuration			4		4	
Downlink power allocation	ρ_A	dB	-3		-3	
	ρ_B	dB	-3		-3	
	σ	dB	0		0	
Propagation condition and antenna configuration			2 x 2 EPA5		2 x 2 EPA5	
CodeBookSubsetRestriction bitmap			01 for fixed RI = 1 10 for fixed RI = 2 11 for UE reported RI	N/A	01 for fixed RI = 1 10 for fixed RI = 2 11 for UE reported RI	N/A
Antenna correlation			Low		Low	
RI configuration			Fixed RI=1 and follow RI	N/A	Fixed RI=1 and follow RI	N/A
\hat{E}_s / N_{oc2}		dB	0	-12	20	6
$N_{oc}^{(j)}$	$N_{oc1}^{(j)}$	dB[mW/1 5kHz]	-98 (Note 4)	N/A	-102 (Note 4)	N/A
	$N_{oc2}^{(j)}$		-98 (Note 5)	N/A	-98 (Note 5)	N/A
	$N_{oc3}^{(j)}$		-98 (Note 6)	N/A	-94.8 (Note 6)	N/A
$\hat{I}_{or}^{(j)}$		dB[mW/1 5kHz]	-98	-110	-78	-92
Subframe Configuration			Non-MBSFN	Non-MBSFN	Non-MBSFN	Non-MBSFN
Cell Id			0	1	0	1
Time Offset between Cells		μ s	2.5 (synchronous cells)		2.5 (synchronous cells)	
ABS Pattern (Note 7)			N/A	00000000 1 00000000 1	N/A	000000001 000000001
RLM/RRM Measurement Subframe Pattern (Note 8)			00000000 01 00000000 01	N/A	000000001 000000001	N/A
CSI Subframe Sets (Note 9)	$C_{CSI,0}$		00000000 01 00000000 01	N/A	000000001 000000001	N/A
	$C_{CSI,1}$		11001110 00 11001110 00		1100111000 1100111000	
Number of control OFDM Symbols			3	3	3	3
Maximum number of HARQ transmissions			1		1	
Reporting mode			PUCCH 1-0		PUCCH 1-0	
Physical channel for $C_{CSI,0}$ CQI and RI reporting			PUCCH Format 2		PUCCH Format 2	
PUCCH Report Type for CQI			4		4	

Physical channel for C _{CSI,1} CQI and RI reporting		PUSCH (Note 3)		PUSCH (Note 3)	
PUCCH Report Type for RI		3		3	
Reporting periodicity	ms	$N_{pd}=10$		$N_{pd}=10$	
ACK/NACK feedback mode		Multiplexing		Multiplexing	
<i>cqi-pmi-ConfigurationIndex</i>		8		8	
<i>ri-ConfigurationInd</i>		5		5	
<i>cqi-pmi-ConfigurationIndex2</i>		9		9	
<i>ri-ConfigurationInd2</i>		0		0	
Cyclic prefix		Normal	Normal	Normal	Normal
Note 1:	If the UE reports in an available uplink reporting instance at subframe SF# <i>n</i> based on CQI estimation at a downlink subframe not later than SF#(<i>n</i> -4), this reported wideband CQI cannot be applied at the eNB downlink before SF#(<i>n</i> +4).				
Note 2:	Reference measurement channel RC.2 TDD in Cell 1 according to Table A.4-1 with one sided dynamic OCNB Pattern OP.1 TDD as described in Annex A.5.2.1.				
Note 3:	To avoid collisions between RI/CQI reports and HARQ-ACK it is necessary to report them on PUSCH instead of PUCCH. PDCCH DCI format 0 shall be transmitted in downlink SF #9 to allow periodic RI/CQI to multiplex with the HARQ-ACK on PUSCH in uplink subframe SF#3.				
Note 4:	This noise is applied in OFDM symbols #1, #2, #3, #5, #6, #8, #9, #10, #12, #13 of a subframe overlapping with the aggressor ABS				
Note 5:	This noise is applied in OFDM symbols #0, #4, #7, #11 of a subframe overlapping with the aggressor ABS.				
Note 6:	This noise is applied in all OFDM symbols of a subframe overlapping with aggressor non-ABS				
Note 7:	ABS pattern as defined in [9]. PDSCH other than SIB1/paging and its associated PDCCH/PCFICH are transmitted in the serving cell subframe when the subframe is overlapped with the ABS subframe of aggressor cell and the subframe is available in the definition of the reference channel.				
Note 8:	Time-domain measurement resource restriction pattern for PCell measurements as defined in [7].				
Note 9:	As configured according to the time-domain measurement resource restriction pattern for CSI measurements defined in [7].				
Note 10:	Cell 1 is the serving cell. Cell 2 is the aggressor cell. The number of the CRS ports in Cell 1 and Cell 2 is the same.				
Note 11:	Downlink physical channel setup in Cell 2 in accordance with Annex C.3.3 applying OCNB pattern as defined in Annex A.5.2.5.				

Table 9.5.3.2-2 Minimum requirement (TDD)

	Test 1	Test 2
γ	0.9	1.05
UE Category	2-8	2-8

9.6 Additional requirements for carrier aggregation

This clause includes requirements for the reporting of channel state information (CSI) with the UE configured for carrier aggregation. The purpose is to verify that the channel state for each cell is correctly reported with multiple cells configured for periodic reporting.

9.6.1 Periodic reporting on multiple cells (Cell-Specific Reference Symbols)

9.6.1.1 FDD

The following requirements apply to UE Category 3-8. For the parameters specified in Table 9.6.1.1-1 and Table 9.6.1.1-2, and using the downlink physical channels specified in tables C.3.2-1 and C.3.2-2 on each cell, the difference between the wideband CQI indices of Pcell and Scell reported shall be such that

$$\text{wideband CQI}_{\text{Pcell}} - \text{wideband CQI}_{\text{Scell}} \geq 2$$

for more than 90% of the time.

Table 9.6.1.1-1: Parameters for PUCCH 1-0 static test on multiple cells (FDD)

Parameter	Unit	Pcell	Scell
PDSCH transmission mode			1
Downlink power allocation	ρ_A	dB	0
	ρ_B	dB	0
Propagation condition and antenna configuration		AWGN (1 x 2)	
SNR	dB	10	4
$\hat{I}_{or}^{(j)}$	dB[mW/15kHz]	-88	-94
$N_{oc}^{(j)}$	dB[mW/15kHz]	-98	-98
Physical channel for CQI reporting		PUCCH Format 2	
PUCCH Report Type		4	
Reporting periodicity	ms	$N_{pd} = 10$	
<i>cqi-pmi-ConfigurationIndex</i>		11	16 [shift of 5 ms relative to Pcell]
Note 1: 3 symbols are allocated to PDCCH. No PDSCH for user data is scheduled for the UE with one sided dynamic OCNG Pattern OP.1 FDD as described in Annex A.5.1.1.			

Table 9.6.1.1-2: PUCCH 1-0 static test (FDD)

Test number	Bandwidth combination
1	10MHz for both cells
2	20MHz for both cells
Note 1: The applicability of requirements for different CA configurations and bandwidth combination sets is defined in 9.1.1.2.	

9.6.1.2 TDD

The following requirements apply to UE Category 3-8. For the parameters specified in Table 9.6.1.2-1 and Table 9.6.1.2-2, and using the downlink physical channels specified in tables C.3.2-1 and C.3.2-2 on each cell, the difference between the wideband CQI indices of Pcell and Scell reported shall be such that

$$\text{wideband CQI}_{\text{Pcell}} - \text{wideband CQI}_{\text{Scell}} \geq 2$$

for more than 90% of the time.

Table 9.6.1.2-1: PUCCH 1-0 static test on multiple cells (TDD)

Parameter		Unit	Pcell	Scell
PDSCH transmission mode				1
Uplink downlink configuration				2
Special subframe configuration				4
Downlink power allocation	ρ_A	dB		0
	ρ_B	dB		0
Propagation condition and antenna configuration			AWGN (1 x 2)	
SNR		dB	10	4
$\hat{I}_{or}^{(j)}$		dB[mW/15kHz]	-88	-94
$N_{oc}^{(j)}$		dB[mW/15kHz]	-98	-98
Physical channel for CQI reporting			PUCCH Format 2	
PUCCH Report Type			4	
Reporting periodicity		ms	$N_{pd} = 10$	
<i>cqi-pmi-ConfigurationIndex</i>			8	13 [shift of 5 ms relative to Pcell]
Note 1: 3 symbols are allocated to PDCCH. No PDSCH for user data is scheduled for the UE with one sided dynamic OCNG Pattern OP.1 TDD as described in Annex A.5.2.1.				

Table 9.6.1.2-2: PUCCH 1-0 static test (TDD)

Test number	Bandwidth combination
1	20MHz for both cells
Note 1: The applicability of requirements for different CA configurations and bandwidth combination sets is defined in 9.1.1.2.	

10 Performance requirement (MBMS)

10.1 FDD (Fixed Reference Channel)

The parameters specified in Table 10.1-1 are valid for all FDD tests unless otherwise stated. For the requirements defined in this section, the difference between CRS EPRE and the MBSFN RS EPRE should be set to 0 dB as the UE demodulation performance might be different when this condition is not met (e.g. in scenarios where power offsets are present, such as scenarios when reserved cells are present).

Table 10.1-1: Common Test Parameters (FDD)

Parameter	Unit	Value
Number of HARQ processes	Processes	None
Subcarrier spacing	kHz	15 kHz
Allocated subframes per Radio Frame (Note 1)		6 subframes
Number of OFDM symbols for PDCCH		2
Cyclic Prefix		Extended
Note1: For FDD mode, up to 6 subframes (#1/2/3/6/7/8) are available for MBMS, in line with TS 36.331.		

10.1.1 Minimum requirement

The receive characteristic of MBMS is determined by the BLER. The requirement is valid for all RRC states for which the UE has capabilities for MBMS.

For the parameters specified in Table 10.1-1 and Table 10.1.1-1 and Annex A.3.8.1, the average downlink SNR shall be below the specified value for the BLER shown in Table 10.1.1-2.

Table 10.1.1-1: Test Parameters for Testing

Parameter		Unit	Test 1-4
Downlink power allocation	ρ_A	dB	0
	ρ_B	dB	0 (Note 1)
	σ	dB	0
N_{oc} at antenna port		dBm/15kHz	-98
Note 1: $P_B = 0$.			

Table 10.1.1-2: Minimum performance

Test number	Bandwidth	Reference Channel	OCNG Pattern	Propagation condition	Correlation Matrix and antenna	Reference value		MBMS UE Category
						BLER (%)	SNR(dB)	
1	10 MHz	R.37 FDD	OP.4 FDD	MBSFN channel model (Table B.2.6-1)	1x2 low	1	4.1	1-8
2	10 MHz	R.38 FDD	OP.4 FDD				11.0	1-8
3	10 MHz	R.39 FDD	OP.4 FDD				20.1	2-8
	5.0MHz	R.39-1 FDD	OP.4 FDD				20.5	1

10.2 TDD (Fixed Reference Channel)

The parameters specified in Table 10.2-1 are valid for all TDD tests unless otherwise stated. For the requirements defined in this section, the difference between CRS EPRE and the MBSFN RS EPRE should be set to 0 dB as the UE demodulation performance might be different when this condition is not met (e.g. in scenarios where power offsets are present, such as scenarios when reserved cells are present).

Table 10.2-1: Common Test Parameters (TDD)

Parameter	Unit	Value
Number of HARQ processes	Processes	None
Subcarrier spacing	kHz	15 kHz
Allocated subframes per Radio Frame (Note 1)		5 subframes
Number of OFDM symbols for PDCCH		2
Cyclic Prefix		Extended
Note1: For TDD mode, in line with TS 36.331, Uplink-Downlink Configuration 5 is proposed, up to 5 subframes (#3/4/7/8/9) are available for MBMS.		

10.2.1 Minimum requirement

The receive characteristic of MBMS is determined by the BLER. The requirement is valid for all RRC states for which the UE has capabilities for MBMS.

For the parameters specified in Table 10.2-1 and Table 10.2.1-1 and Annex A.3.8.2, the average downlink SNR shall be below the specified value for the BLER shown in Table 10.2.1-2.

Table 10.2.1-1: Test Parameters for Testing

Parameter		Unit	Test 1-4
Downlink power allocation	ρ_A	dB	0
	ρ_B	dB	0 (Note 1)
	σ	dB	0
N_{oc} at antenna port		dBm/15kHz	-98
Note 1: $P_B = 0$.			

Table 10.2.1-2: Minimum performance

Test number	Bandwidth	Reference Channel	OCNG Pattern	Propagation condition	Correlation Matrix and antenna	Reference value		MBMS UE Category
						BLER (%)	SNR(dB)	
1	10 MHz	R.37 TDD	OP.4 TDD	MBSFN channel model (Table B.2.6-1)	1x2 low	1	3.4	1-8
2	10 MHz	R.38 TDD	OP.4 TDD				11.1	1-8
3a	10 MHz	R.39 TDD	OP.4 TDD				20.1	2-8
3b	5MHz	R.39-1 TDD	OP.4 TDD				20.5	1
4	1.4 MHz	R.40 TDD	OP.4 TDD				5.8	1-8

Annex A (normative): Measurement channels

A.1 General

The throughput values defined in the measurement channels specified in Annex A, are calculated and are valid per datastream (codeword). For multi-stream (more than one codeword) transmissions, the throughput referenced in the minimum requirements is the sum of throughputs of all datastreams (codewords).

The UE category entry in the definition of the reference measurement channel in Annex A is only informative and reveals the UE categories, which can support the corresponding measurement channel. Whether the measurement channel is used for testing a certain UE category or not is specified in the individual minimum requirements.

A.2 UL reference measurement channels

A.2.1 General

The measurement channels in the following subclauses are defined to derive the requirements in clause 6 (Transmitter Characteristics) and clause 7 (Receiver Characteristics). The measurement channels represent example configurations of physical channels for different data rates.

A.2.1.1 Applicability and common parameters

The UL reference measurement channels comprise assume transmission of PUSCH and Demodulation Reference signals only. The following conditions apply:

- 1 HARQ transmission
- Cyclic Prefix normal
- PUSCH hopping off
- Link adaptation off
- Demodulation Reference signal as per TS 36.211 [4] subclause 5.5.2.1.2.

Where ACK/NACK is transmitted, it is assumed to be multiplexed on PUSCH as per TS 36.212 [5] subclause 5.2.2.6.

- ACK/NACK 1 bit
- ACK/NACK mapping adjacent to Demodulation Reference symbol
- ACK/NACK resources punctured into data
- Max number of resources for ACK/NACK: 4 SC-FDMA symbols per subframe
- No CQI transmitted, no RI transmitted

A.2.1.2 Determination of payload size

The algorithm for determining the payload size A is as follows; given a desired coding rate R and radio block allocation N_{RB}

1. Calculate the number of channel bits N_{ch} that can be transmitted during the first transmission of a given sub-frame.
2. Find A such that the resulting coding rate is as close to R as possible, that is,

$$\min |R - (A + 24) / N_{ch}|,$$

subject to

- a) A is a valid TB size according to section 7.1.7 of TS 36.213 [6] assuming an allocation of N_{RB} resource blocks.
- b) Segmentation is not included in this formula, but should be considered in the TBS calculation.
- c) For RMC-s, which at the nominal target coding rate do not cover all the possible UE categories for the given modulation, reduce the target coding rate gradually (within the same modulation), until the maximal possible number of UE categories is covered.

3. If there is more than one A that minimises the equation above, then the larger value is chosen per default.

A.2.1.3 Overview of UL reference measurement channels

In Table A.2.1.3-1 are listed the UL reference measurement channels specified in annexes A.2.2 and A.2.3 of this release of TS 36.101. This table is informative and serves only to a better overview. The reference for the concrete reference measurement channels and corresponding implementation's parameters as to be used for requirements are annexes A.2.2 and A.2.3 as appropriate.

Table A.2.1.3-1: Overview of UL reference measurement channels

Duplex	Table	Name	BW	Mod	TCR	RB	RB Off set	UE Cat eg	Notes
FDD, Full RB allocation, QPSK									
FDD	Table A.2.2.1.1-1		1.4	QPSK	1/3	6		≥ 1	
FDD	Table A.2.2.1.1-1		3	QPSK	1/3	15		≥ 1	
FDD	Table A.2.2.1.1-1		5	QPSK	1/3	25		≥ 1	
FDD	Table A.2.2.1.1-1		10	QPSK	1/3	50		≥ 1	
FDD	Table A.2.2.1.1-1		15	QPSK	1/5	75		≥ 1	
FDD	Table A.2.2.1.1-1		20	QPSK	1/6	100		≥ 1	
FDD, Full RB allocation, 16-QAM									
FDD	Table A.2.2.1.2-1		1.4	16QAM	3/4	6		≥ 1	
FDD	Table A.2.2.1.2-1		3	16QAM	1/2	15		≥ 1	
FDD	Table A.2.2.1.2-1		5	16QAM	1/3	25		≥ 1	
FDD	Table A.2.2.1.2-1		10	16QAM	3/4	50		≥ 2	
FDD	Table A.2.2.1.2-1		15	16QAM	1/2	75		≥ 2	
FDD	Table A.2.2.1.2-1		20	16QAM	1/3	100		≥ 2	
FDD, Partial RB allocation, QPSK									
FDD	Table A.2.2.2.1-1		1.4 - 20	QPSK	1/3	1		≥ 1	
FDD	Table A.2.2.2.1-1		1.4 - 20	QPSK	1/3	2		≥ 1	
FDD	Table A.2.2.2.1-1		1.4 - 20	QPSK	1/3	3		≥ 1	
FDD	Table A.2.2.2.1-1		1.4 - 20	QPSK	1/3	4		≥ 1	
FDD	Table A.2.2.2.1-1		1.4 - 20	QPSK	1/3	5		≥ 1	
FDD	Table A.2.2.2.1-1		3 - 20	QPSK	1/3	6		≥ 1	
FDD	Table A.2.2.2.1-1		3 - 20	QPSK	1/3	8		≥ 1	
FDD	Table A.2.2.2.1-1		3 - 20	QPSK	1/3	9		≥ 1	
FDD	Table A.2.2.2.1-1		3 - 20	QPSK	1/3	10		≥ 1	
FDD	Table A.2.2.2.1-1		3 - 20	QPSK	1/3	12		≥ 1	
FDD	Table A.2.2.2.1-1		5 - 20	QPSK	1/3	15		≥ 1	
FDD	Table A.2.2.2.1-1		5 - 20	QPSK	1/3	16		≥ 1	
FDD	Table A.2.2.2.1-1		5 - 20	QPSK	1/3	18		≥ 1	
FDD	Table A.2.2.2.1-1		5 - 20	QPSK	1/3	20		≥ 1	
FDD	Table A.2.2.2.1-1		5 - 20	QPSK	1/3	24		≥ 1	
FDD	Table A.2.2.2.1-1		10 - 20	QPSK	1/3	25		≥ 1	
FDD	Table A.2.2.2.1-1		10 - 20	QPSK	1/3	27		≥ 1	
FDD	Table A.2.2.2.1-1		10 - 20	QPSK	1/3	30		≥ 1	
FDD	Table A.2.2.2.1-1		10 - 20	QPSK	1/3	32		≥ 1	
FDD	Table A.2.2.2.1-1		10 - 20	QPSK	1/3	36		≥ 1	
FDD	Table A.2.2.2.1-1		10 - 20	QPSK	1/3	40		≥ 1	
FDD	Table A.2.2.2.1-1		10 - 20	QPSK	1/3	45		≥ 1	
FDD	Table A.2.2.2.1-1		10 - 20	QPSK	1/3	48		≥ 1	
FDD	Table A.2.2.2.1-1		15 - 20	QPSK	1/3	50		≥ 1	
FDD	Table A.2.2.2.1-1		15 - 20	QPSK	1/3	54		≥ 1	
FDD	Table A.2.2.2.1-1		15 - 20	QPSK	1/4	60		≥ 1	
FDD	Table A.2.2.2.1-1		15 - 20	QPSK	1/4	64		≥ 1	
FDD	Table A.2.2.2.1-1		15 - 20	QPSK	1/4	72		≥ 1	
FDD	Table A.2.2.2.1-1		20	QPSK	1/5	75		≥ 1	
FDD	Table A.2.2.2.1-1		20	QPSK	1/5	80		≥ 1	

FDD	Table A.2.2.2.1-1		20	QPSK	1/5	81		≥ 1	
FDD	Table A.2.2.2.1-1		20	QPSK	1/6	90		≥ 1	
FDD	Table A.2.2.2.1-1		20	QPSK	1/6	96		≥ 1	
FDD, Partial RB allocation, 16-QAM									
FDD	Table A.2.2.2.2-1		1.4 - 20	16QAM	3/4	1		≥ 1	
FDD	Table A.2.2.2.2-1		1.4 - 20	16QAM	3/4	2		≥ 1	
FDD	Table A.2.2.2.2-1		1.4 - 20	16QAM	3/4	3		≥ 1	
FDD	Table A.2.2.2.2-1		1.4 - 20	16QAM	3/4	4		≥ 1	
FDD	Table A.2.2.2.2-1		1.4 - 20	16QAM	3/4	5		≥ 1	
FDD	Table A.2.2.2.2-1		3 - 20	16QAM	3/4	6		≥ 1	
FDD	Table A.2.2.2.2-1		3 - 20	16QAM	3/4	8		≥ 1	
FDD	Table A.2.2.2.2-1		3 - 20	16QAM	3/4	9		≥ 1	
FDD	Table A.2.2.2.2-1		3 - 20	16QAM	3/4	10		≥ 1	
FDD	Table A.2.2.2.2-1		3 - 20	16QAM	3/4	12		≥ 1	
FDD	Table A.2.2.2.2-1		5 - 20	16QAM	1/2	15		≥ 1	
FDD	Table A.2.2.2.2-1		5 - 20	16QAM	1/2	16		≥ 1	
FDD	Table A.2.2.2.2-1		5 - 20	16QAM	1/2	18		≥ 1	
FDD	Table A.2.2.2.2-1		5 - 20	16QAM	1/3	20		≥ 1	
FDD	Table A.2.2.2.2-1		5 - 20	16QAM	1/3	24		≥ 1	
FDD	Table A.2.2.2.2-1		10 - 20	16QAM	1/3	25		≥ 1	
FDD	Table A.2.2.2.2-1		10 - 20	16QAM	1/3	27		≥ 1	
FDD	Table A.2.2.2.2-1		10 - 20	16QAM	3/4	30		≥ 2	
FDD	Table A.2.2.2.2-1		10 - 20	16QAM	3/4	32		≥ 2	
FDD	Table A.2.2.2.2-1		10 - 20	16QAM	3/4	36		≥ 2	
FDD	Table A.2.2.2.2-1		10 - 20	16QAM	3/4	40		≥ 2	
FDD	Table A.2.2.2.2-1		10 - 20	16QAM	3/4	45		≥ 2	
FDD	Table A.2.2.2.2-1		10 - 20	16QAM	3/4	48		≥ 2	
FDD	Table A.2.2.2.2-1		15 - 20	16QAM	3/4	50		≥ 2	
FDD	Table A.2.2.2.2-1		15 - 20	16QAM	3/4	54		≥ 2	
FDD	Table A.2.2.2.2-1		15 - 20	16QAM	2/3	60		≥ 2	
FDD	Table A.2.2.2.2-1		15 - 20	16QAM	2/3	64		≥ 2	
FDD	Table A.2.2.2.2-1		15 - 20	16QAM	1/2	72		≥ 2	
FDD	Table A.2.2.2.2-1		20	16QAM	1/2	75		≥ 2	
FDD	Table A.2.2.2.2-1		20	16QAM	1/2	80		≥ 2	
FDD	Table A.2.2.2.2-1		20	16QAM	1/2	81		≥ 2	
FDD	Table A.2.2.2.2-1		20	16QAM	2/5	90		≥ 2	
FDD	Table A.2.2.2.2-1		20	16QAM	2/5	96		≥ 2	
TDD, Full RB allocation, QPSK									
TDD	Table A.2.3.1.1-1		1.4	QPSK	1/3	6		≥ 1	
TDD	Table A.2.3.1.1-1		3	QPSK	1/3	15		≥ 1	
TDD	Table A.2.3.1.1-1		5	QPSK	1/3	25		≥ 1	
TDD	Table A.2.3.1.1-1		10	QPSK	1/3	50		≥ 1	
TDD	Table A.2.3.1.1-1		15	QPSK	1/5	75		≥ 1	
TDD	Table A.2.3.1.1-1		20	QPSK	1/6	100		≥ 1	
TDD, Full RB allocation, 16-QAM									
TDD	Table A.2.3.1.2-1		1.4	16QAM	3/4	6		≥ 1	
TDD	Table A.2.3.1.2-1		3	16QAM	1/2	15		≥ 1	
TDD	Table A.2.3.1.2-1		5	16QAM	1/3	25		≥ 1	

TDD	Table A.2.3.1.2-1		10	16QAM	3/4	50		≥ 2	
TDD	Table A.2.3.1.2-1		15	16QAM	1/2	75		≥ 2	
TDD	Table A.2.3.1.2-1		20	16QAM	1/3	100		≥ 2	
TDD, Partial RB allocation, QPSK									
TDD	Table A.2.3.2.1-1		1.4 - 20	QPSK	1/3	1		≥ 1	
TDD	Table A.2.3.2.1-1		1.4 - 20	QPSK	1/3	2		≥ 1	
TDD	Table A.2.3.2.1-1		1.4 - 20	QPSK	1/3	3		≥ 1	
TDD	Table A.2.3.2.1-1		1.4 - 20	QPSK	1/3	4		≥ 1	
TDD	Table A.2.3.2.1-1		1.4 - 20	QPSK	1/3	5		≥ 1	
TDD	Table A.2.3.2.1-1		3 - 20	QPSK	1/3	6		≥ 1	
TDD	Table A.2.3.2.1-1		3 - 20	QPSK	1/3	8		≥ 1	
TDD	Table A.2.3.2.1-1		3 - 20	QPSK	1/3	9		≥ 1	
TDD	Table A.2.3.2.1-1		3 - 20	QPSK	1/3	10		≥ 1	
TDD	Table A.2.3.2.1-1		3 - 20	QPSK	1/3	12		≥ 1	
TDD	Table A.2.3.2.1-1		5 - 20	QPSK	1/3	15		≥ 1	
TDD	Table A.2.3.2.1-1		5 - 20	QPSK	1/3	16		≥ 1	
TDD	Table A.2.3.2.1-1		5 - 20	QPSK	1/3	18		≥ 1	
TDD	Table A.2.3.2.1-1		5 - 20	QPSK	1/3	20		≥ 1	
TDD	Table A.2.3.2.1-1		5 - 20	QPSK	1/3	24		≥ 1	
TDD	Table A.2.3.2.1-1		10 - 20	QPSK	1/3	25		≥ 1	
TDD	Table A.2.3.2.1-1		10 - 20	QPSK	1/3	27		≥ 1	
TDD	Table A.2.3.2.1-1		10 - 20	QPSK	1/3	30		≥ 1	
TDD	Table A.2.3.2.1-1		10 - 20	QPSK	1/3	32		≥ 1	
TDD	Table A.2.3.2.1-1		10 - 20	QPSK	1/3	36		≥ 1	
TDD	Table A.2.3.2.1-1		10 - 20	QPSK	1/3	40		≥ 1	
TDD	Table A.2.3.2.1-1		10 - 20	QPSK	1/3	45		≥ 1	
TDD	Table A.2.3.2.1-1		10 - 20	QPSK	1/3	48		≥ 1	
TDD	Table A.2.3.2.1-1		15 - 20	QPSK	1/3	50		≥ 1	
TDD	Table A.2.3.2.1-1		15 - 20	QPSK	1/3	54		≥ 1	
TDD	Table A.2.3.2.1-1		15 - 20	QPSK	1/4	60		≥ 1	
TDD	Table A.2.3.2.1-1		15 - 20	QPSK	1/4	64		≥ 1	
TDD	Table A.2.3.2.1-1		15 - 20	QPSK	1/4	72		≥ 1	
TDD	Table A.2.3.2.1-1		20	QPSK	1/5	75		≥ 1	
TDD	Table A.2.3.2.1-1		20	QPSK	1/5	80		≥ 1	
TDD	Table A.2.3.2.1-1		20	QPSK	1/5	81		≥ 1	
TDD	Table A.2.3.2.1-1		20	QPSK	1/6	90		≥ 1	
TDD	Table A.2.3.2.1-1		20	QPSK	1/6	96		≥ 1	
TDD, Partial RB allocation, 16-QAM									
TDD	Table A.2.3.2.2-1		1.4 - 20	16QAM	3/4	1		≥ 1	
TDD	Table A.2.3.2.2-1		1.4 - 20	16QAM	3/4	2		≥ 1	
TDD	Table A.2.3.2.2-1		1.4 - 20	16QAM	3/4	3		≥ 1	
TDD	Table A.2.3.2.2-1		1.4 - 20	16QAM	3/4	4		≥ 1	
TDD	Table A.2.3.2.2-1		1.4 - 20	16QAM	3/4	5		≥ 1	
TDD	Table A.2.3.2.2-1		3 - 20	16QAM	3/4	6		≥ 1	
TDD	Table A.2.3.2.2-1		3 - 20	16QAM	3/4	8		≥ 1	
TDD	Table A.2.3.2.2-1		3 - 20	16QAM	3/4	9		≥ 1	
TDD	Table A.2.3.2.2-1		3 - 20	16QAM	3/4	10		≥ 1	
TDD	Table A.2.3.2.2-1		3 - 20	16QAM	3/4	12		≥ 1	

TDD	Table A.2.3.2.2-1		5 - 20	16QAM	1/2	15		≥ 1	
TDD	Table A.2.3.2.2-1		5 - 20	16QAM	1/2	16		≥ 1	
TDD	Table A.2.3.2.2-1		5 - 20	16QAM	1/2	18		≥ 1	
TDD	Table A.2.3.2.2-1		5 - 20	16QAM	1/3	20		≥ 1	
TDD	Table A.2.3.2.2-1		5 - 20	16QAM	1/3	24		≥ 1	
TDD	Table A.2.3.2.2-1		10 - 20	16QAM	1/3	25		≥ 1	
TDD	Table A.2.3.2.2-1		10 - 20	16QAM	1/3	27		≥ 1	
TDD	Table A.2.3.2.2-1		10 - 20	16QAM	3/4	30		≥ 2	
TDD	Table A.2.3.2.2-1		10 - 20	16QAM	3/4	32		≥ 2	
TDD	Table A.2.3.2.2-1		10 - 20	16QAM	3/4	36		≥ 2	
TDD	Table A.2.3.2.2-1		10 - 20	16QAM	3/4	40		≥ 2	
TDD	Table A.2.3.2.2-1		10 - 20	16QAM	3/4	45		≥ 2	
TDD	Table A.2.3.2.2-1		10 - 20	16QAM	3/4	48		≥ 2	
TDD	Table A.2.3.2.2-1		15 - 20	16QAM	3/4	50		≥ 2	
TDD	Table A.2.3.2.2-1		15 - 20	16QAM	3/4	54		≥ 2	
TDD	Table A.2.3.2.2-1		15 - 20	16QAM	2/3	60		≥ 2	
TDD	Table A.2.3.2.2-1		15 - 20	16QAM	2/3	64		≥ 2	
TDD	Table A.2.3.2.2-1		15 - 20	16QAM	1/2	72		≥ 2	
TDD	Table A.2.3.2.2-1		20	16QAM	1/2	75		≥ 2	
TDD	Table A.2.3.2.2-1		20	16QAM	1/2	80		≥ 2	
TDD	Table A.2.3.2.2-1		20	16QAM	1/2	81		≥ 2	
TDD	Table A.2.3.2.2-1		20	16QAM	2/5	90		≥ 2	
TDD	Table A.2.3.2.2-1		20	16QAM	2/5	96		≥ 2	

A.2.2 Reference measurement channels for FDD

A.2.2.1 Full RB allocation

A.2.2.1.1 QPSK

Table A.2.2.1.1-1 Reference Channels for QPSK with full RB allocation

Parameter	Unit	Value					
		1.4	3	5	10	15	20
Channel bandwidth	MHz	1.4	3	5	10	15	20
Allocated resource blocks		6	15	25	50	75	100
DFT-OFDM Symbols per Sub-Frame		12	12	12	12	12	12
Modulation		QPSK	QPSK	QPSK	QPSK	QPSK	QPSK
Target Coding rate		1/3	1/3	1/3	1/3	1/5	1/6
Payload size	Bits	600	1544	2216	5160	4392	4584
Transport block CRC	Bits	24	24	24	24	24	24
Number of code blocks per Sub-Frame (Note 1)		1	1	1	1	1	1
Total number of bits per Sub-Frame	Bits	1728	4320	7200	14400	21600	28800
Total symbols per Sub-Frame		864	2160	3600	7200	10800	14400
UE Category		≥ 1	≥ 1	≥ 1	≥ 1	≥ 1	≥ 1
Note 1: If more than one Code Block is present, an additional CRC sequence of L = 24 Bits is attached to each Code Block (otherwise L = 0 Bit)							

A.2.2.1.2 16-QAM

Table A.2.2.1.2-1 Reference Channels for 16-QAM with full RB allocation

Parameter	Unit	Value					
		1.4	3	5	10	15	20
Channel bandwidth	MHz	1.4	3	5	10	15	20
Allocated resource blocks		6	15	25	50	75	100
DFT-OFDM Symbols per Sub-Frame		12	12	12	12	12	12
Modulation		16QAM	16QAM	16QAM	16QAM	16QAM	16QAM
Target Coding rate		3/4	1/2	1/3	3/4	1/2	1/3
Payload size	Bits	2600	4264	4968	21384	21384	19848
Transport block CRC	Bits	24	24	24	24	24	24
Number of code blocks per Sub-Frame (Note 1)		1	1	1	4	4	4
Total number of bits per Sub-Frame	Bits	3456	8640	14400	28800	43200	57600
Total symbols per Sub-Frame		864	2160	3600	7200	10800	14400
UE Category		≥ 1	≥ 1	≥ 1	≥ 2	≥ 2	≥ 2
Note 1: If more than one Code Block is present, an additional CRC sequence of L = 24 Bits is attached to each Code Block (otherwise L = 0 Bit)							

A.2.2.1.3 64-QAM

[FFS]

A.2.2.2 Partial RB allocation

For each channel bandwidth, various partial RB allocations are specified. The number of allocated RBs is chosen according to values specified in the Tx and Rx requirements. The single allocated RB case is included.

The allocated RBs are contiguous and start from one end of the channel bandwidth. A single allocated RB is at one end of the channel bandwidth.

A.2.2.2.1 QPSK

Table A.2.2.2.1-1 Reference Channels for QPSK with partial RB allocation

Parameter	Ch BW	Allocated RBs	DFT-OFDM Symbols per Sub-Frame	Mod'n	Target Coding rate	Payload size	Transport block CRC	Number of code blocks per Sub-Frame (Note 1)	Total number of bits per Sub-Frame	Total symbols per Sub-Frame	UE Category
Unit	MHz					Bits	Bits		Bits		
	1.4 - 20	1	12	QPSK	1/3	72	24	1	288	144	≥ 1
	1.4 - 20	2	12	QPSK	1/3	176	24	1	576	288	≥ 1
	1.4 - 20	3	12	QPSK	1/3	256	24	1	864	432	≥ 1
	1.4 - 20	4	12	QPSK	1/3	392	24	1	1152	576	≥ 1
	1.4 - 20	5	12	QPSK	1/3	424	24	1	1440	720	≥ 1
	3-20	6	12	QPSK	1/3	600	24	1	1728	864	≥ 1
	3-20	8	12	QPSK	1/3	808	24	1	2304	1152	≥ 1
	3-20	9	12	QPSK	1/3	776	24	1	2592	1296	≥ 1
	3-20	10	12	QPSK	1/3	872	24	1	2880	1440	≥ 1
	3-20	12	12	QPSK	1/3	1224	24	1	3456	1728	≥ 1
	5-20	15	12	QPSK	1/3	1320	24	1	4320	2160	≥ 1
	5-20	16	12	QPSK	1/3	1384	24	1	4608	2304	≥ 1
	5-20	18	12	QPSK	1/3	1864	24	1	5184	2592	≥ 1
	5-20	20	12	QPSK	1/3	1736	24	1	5760	2880	≥ 1
	5-20	24	12	QPSK	1/3	2472	24	1	6912	3456	≥ 1
	10-20	25	12	QPSK	1/3	2216	24	1	7200	3600	≥ 1
	10-20	27	12	QPSK	1/3	2792	24	1	7776	3888	≥ 1
	10-20	30	12	QPSK	1/3	2664	24	1	8640	4320	≥ 1
	10-20	32	12	QPSK	1/3	2792	24	1	9216	4608	≥ 1
	10-20	36	12	QPSK	1/3	3752	24	1	10368	5184	≥ 1
	10-20	40	12	QPSK	1/3	4136	24	1	11520	5760	≥ 1
	10-20	45	12	QPSK	1/3	4008	24	1	12960	6480	≥ 1
	10-20	48	12	QPSK	1/3	4264	24	1	13824	6912	≥ 1
	15 - 20	50	12	QPSK	1/3	5160	24	1	14400	7200	≥ 1
	15 - 20	54	12	QPSK	1/3	4776	24	1	15552	7776	≥ 1
	15 - 20	60	12	QPSK	1/4	4264	24	1	17280	8640	≥ 1
	15 - 20	64	12	QPSK	1/4	4584	24	1	18432	9216	≥ 1
	15 - 20	72	12	QPSK	1/4	5160	24	1	20736	10368	≥ 1
	20	75	12	QPSK	1/5	4392	24	1	21600	10800	≥ 1
	20	80	12	QPSK	1/5	4776	24	1	23040	11520	≥ 1
	20	81	12	QPSK	1/5	4776	24	1	23328	11664	≥ 1
	20	90	12	QPSK	1/6	4008	24	1	25920	12960	≥ 1
	20	96	12	QPSK	1/6	4264	24	1	27648	13824	≥ 1

Note 1: If more than one Code Block is present, an additional CRC sequence of L = 24 Bits is attached to each Code Block (otherwise L = 0 Bit)

A.2.2.2.2 16-QAM

Table A.2.2.2-1 Reference Channels for 16-QAM with partial RB allocation

Parameter	Ch BW	Allocated RBs	DFT-OFDM Symbols per Sub-Frame	Mod'n	Target Coding rate	Payload size	Transport block CRC	Number of code blocks per Sub-Frame (Note 1)	Total number of bits per Sub-Frame	Total symbols per Sub-Frame	UE Category
Unit	MHz					Bits	Bits		Bits		
	1.4 - 20	1	12	16QAM	3/4	408	24	1	576	144	≥ 1
	1.4 - 20	2	12	16QAM	3/4	840	24	1	1152	288	≥ 1
	1.4 - 20	3	12	16QAM	3/4	1288	24	1	1728	432	≥ 1
	1.4 - 20	4	12	16QAM	3/4	1736	24	1	2304	576	≥ 1
	1.4 - 20	5	12	16QAM	3/4	2152	24	1	2880	720	≥ 1
	3-20	6	12	16QAM	3/4	2600	24	1	3456	864	≥ 1
	3-20	8	12	16QAM	3/4	3496	24	1	4608	1152	≥ 1
	3-20	9	12	16QAM	3/4	3880	24	1	5184	1296	≥ 1
	3-20	10	12	16QAM	3/4	4264	24	1	5760	1440	≥ 1
	3-20	12	12	16QAM	3/4	5160	24	1	6912	1728	≥ 1
	5-20	15	12	16QAM	1/2	4264	24	1	8640	2160	≥ 1
	5-20	16	12	16QAM	1/2	4584	24	1	9216	2304	≥ 1
	5-20	18	12	16QAM	1/2	5160	24	1	10368	2592	≥ 1
	5-20	20	12	16QAM	1/3	4008	24	1	11520	2880	≥ 1
	5-20	24	12	16QAM	1/3	4776	24	1	13824	3456	≥ 1
	10-20	25	12	16QAM	1/3	4968	24	1	14400	3600	≥ 1
	10-20	27	12	16QAM	1/3	4776	24	1	15552	3888	≥ 1
	10-20	30	12	16QAM	3/4	12960	24	3	17280	4320	≥ 2
	10-20	32	12	16QAM	3/4	13536	24	3	18432	4608	≥ 2
	10-20	36	12	16QAM	3/4	15264	24	3	20736	5184	≥ 2
	10-20	40	12	16QAM	3/4	16992	24	3	23040	5760	≥ 2
	10-20	45	12	16QAM	3/4	19080	24	4	25920	6480	≥ 2
	10-20	48	12	16QAM	3/4	20616	24	4	27648	6912	≥ 2
	15 - 20	50	12	16QAM	3/4	21384	24	4	28800	7200	≥ 2
	15 - 20	54	12	16QAM	3/4	22920	24	4	31104	7776	≥ 2
	15 - 20	60	12	16QAM	2/3	23688	24	4	34560	8640	≥ 2
	15 - 20	64	12	16QAM	2/3	25456	24	4	36864	9216	≥ 2
	15 - 20	72	12	16QAM	1/2	20616	24	4	41472	10368	≥ 2
	20	75	12	16QAM	1/2	21384	24	4	43200	10800	≥ 2
	20	80	12	16QAM	1/2	22920	24	4	46080	11520	≥ 2
	20	81	12	16QAM	1/2	22920	24	4	46656	11664	≥ 2
	20	90	12	16QAM	2/5	20616	24	4	51840	12960	≥ 2
	20	96	12	16QAM	2/5	22152	24	4	55296	13824	≥ 2

Note 1: If more than one Code Block is present, an additional CRC sequence of L = 24 Bits is attached to each Code Block (otherwise L = 0 Bit)

A.2.2.2.3 64-QAM

[FFS]

A.2.2.3 Void

Table A.2.2.3-1: Void

A.2.3 Reference measurement channels for TDD

For TDD, the measurement channel is based on DL/UL configuration ratio of 2DL:2UL.

A.2.3.1 Full RB allocation

A.2.3.1.1 QPSK

Table A.2.3.1.1-1 Reference Channels for QPSK with full RB allocation

Parameter	Unit	Value					
Channel bandwidth	MHz	1.4	3	5	10	15	20
Allocated resource blocks		6	15	25	50	75	100
Uplink-Downlink Configuration (Note 2)		1	1	1	1	1	1
DFT-OFDM Symbols per Sub-Frame		12	12	12	12	12	12
Modulation		QPSK	QPSK	QPSK	QPSK	QPSK	QPSK
Target Coding rate		1/3	1/3	1/3	1/3	1/5	1/6
Payload size							
For Sub-Frame 2,3,7,8	Bits	600	1544	2216	5160	4392	4584
Transport block CRC	Bits	24	24	24	24	24	24
Number of code blocks per Sub-Frame (Note 1)							
For Sub-Frame 2,3,7,8		1	1	1	1	1	1
Total number of bits per Sub-Frame							
For Sub-Frame 2,3,7,8	Bits	1728	4320	7200	14400	21600	28800
Total symbols per Sub-Frame							
For Sub-Frame 2,3,7,8		864	2160	3600	7200	10800	14400
UE Category		≥ 1	≥ 1	≥ 1	≥ 1	≥ 1	≥ 1
Note 1:	If more than one Code Block is present, an additional CRC sequence of L = 24 Bits is attached to each Code Block (otherwise L = 0 Bit)						
Note 2:	As per Table 4.2-2 in TS 36.211 [4]						

A.2.3.1.2 16-QAM

Table A.2.3.1.2-1 Reference Channels for 16-QAM with full RB allocation

Parameter	Unit	Value					
Channel bandwidth	MHz	1.4	3	5	10	15	20
Allocated resource blocks		6	15	25	50	75	100
Uplink-Downlink Configuration (Note 2)		1	1	1	1	1	1
DFT-OFDM Symbols per Sub-Frame		12	12	12	12	12	12
Modulation		16QAM	16QAM	16QAM	16QAM	16QAM	16QAM
Target Coding rate		3/4	1/2	1/3	3/4	1/2	1/3
Payload size							
For Sub-Frame 2,3,7,8	Bits	2600	4264	4968	21384	21384	19848
Transport block CRC	Bits	24	24	24	24	24	24
Number of code blocks per Sub-Frame (Note 1)							
For Sub-Frame 2,3,7,8		1	1	1	4	4	4
Total number of bits per Sub-Frame							
For Sub-Frame 2,3,7,8	Bits	3456	8640	14400	28800	43200	57600
Total symbols per Sub-Frame							
For Sub-Frame 2,3,7,8		864	2160	3600	7200	10800	14400
UE Category		≥ 1	≥ 1	≥ 1	≥ 2	≥ 2	≥ 2
Note 1:	If more than one Code Block is present, an additional CRC sequence of L = 24 Bits is attached to each Code Block (otherwise L = 0 Bit)						
Note 2:	As per Table 4.2-2 in TS 36.211 [4]						

A.2.3.1.3 64-QAM

[FFS]

A.2.3.2 Partial RB allocation

For each channel bandwidth, various partial RB allocations are specified. The number of allocated RBs is chosen according to values specified in the Tx and Rx requirements. The single allocated RB case is included.

The allocated RBs are contiguous and start from one end of the channel bandwidth. A single allocated RB is at one end of the channel bandwidth.

A.2.3.2.1 QPSK

Table A.2.3.2.1-1 Reference Channels for QPSK with partial RB allocation

Parameter	Ch BW	Allocated RBs	UDL Configuration (Note 2)	DFT-OFDM Symbols per Sub-Frame	Mod'n	Target Coding rate	Payload size for Sub-Frame 2, 3, 7, 8	Transport block CRC	Number of code blocks per Sub-Frame (Note 1)	Total number of bits per Sub-Frame for Sub-Frame 2, 3, 7, 8	Total symbols per Sub-Frame for Sub-Frame 2, 3, 7, 8	UE Category
Unit	MHz						Bits	Bits		Bits		
	1.4 - 20	1	1	12	QPSK	1/3	72	24	1	288	144	≥ 1
	1.4 - 20	2	1	12	QPSK	1/3	176	24	1	576	288	≥ 1
	1.4 - 20	3	1	12	QPSK	1/3	256	24	1	864	432	≥ 1
	1.4 - 20	4	1	12	QPSK	1/3	392	24	1	1152	576	≥ 1
	1.4 - 20	5	1	12	QPSK	1/3	424	24	1	1440	720	≥ 1
	3-20	6	1	12	QPSK	1/3	600	24	1	1728	864	≥ 1
	3-20	8	1	12	QPSK	1/3	808	24	1	2304	1152	≥ 1
	3-20	9	1	12	QPSK	1/3	776	24	1	2592	1296	≥ 1
	3-20	10	1	12	QPSK	1/3	872	24	1	2880	1440	≥ 1
	3-20	12	1	12	QPSK	1/3	1224	24	1	3456	1728	≥ 1
	5-20	15	1	12	QPSK	1/3	1320	24	1	4320	2160	≥ 1
	5-20	16	1	12	QPSK	1/3	1384	24	1	4608	2304	≥ 1
	5-20	18	1	12	QPSK	1/3	1864	24	1	5184	2592	≥ 1
	5-20	20	1	12	QPSK	1/3	1736	24	1	5760	2880	≥ 1
	5-20	24	1	12	QPSK	1/3	2472	24	1	6912	3456	≥ 1
	10-20	25	1	12	QPSK	1/3	2216	24	1	7200	3600	≥ 1
	10-20	27	1	12	QPSK	1/3	2792	24	1	7776	3888	≥ 1
	10-20	30	1	12	QPSK	1/3	2664	24	1	8640	4320	≥ 1
	10-20	32	1	12	QPSK	1/3	2792	24	1	9216	4608	≥ 1
	10-20	36	1	12	QPSK	1/3	3752	24	1	10368	5184	≥ 1
	10-20	40	1	12	QPSK	1/3	4136	24	1	11520	5760	≥ 1
	10-20	45	1	12	QPSK	1/3	4008	24	1	12960	6480	≥ 1
	10-20	48	1	12	QPSK	1/3	4264	24	1	13824	6912	≥ 1
	15 - 20	50	1	12	QPSK	1/3	5160	24	1	14400	7200	≥ 1
	15 - 20	54	1	12	QPSK	1/3	4776	24	1	15552	7776	≥ 1
	15 - 20	60	1	12	QPSK	1/4	4264	24	1	17280	8640	≥ 1
	15 - 20	64	1	12	QPSK	1/4	4584	24	1	18432	9216	≥ 1
	15 - 20	72	1	12	QPSK	1/4	5160	24	1	20736	10368	≥ 1
	20	75	1	12	QPSK	1/5	4392	24	1	21600	10800	≥ 1
	20	80	1	12	QPSK	1/5	4776	24	1	23040	11520	≥ 1
	20	81	1	12	QPSK	1/5	4776	24	1	23328	11664	≥ 1
	20	90	1	12	QPSK	1/6	4008	24	1	25920	12960	≥ 1
	20	96	1	12	QPSK	1/6	4264	24	1	27648	13824	≥ 1

Note 1: If more than one Code Block is present, an additional CRC sequence of L = 24 Bits is attached to each Code Block (otherwise L = 0 Bit)

Note 2: As per Table 4.2-2 in TS 36.211 [4]

A.2.3.2.2 16-QAM

Table A.2.3.2.2-1 Reference Channels for 16QAM with partial RB allocation

Parameter	Ch BW	Allocated RBs	UDL Configuration (Note 2)	DFT-OFDM Symbols per Sub-Frame	Mod'n	Target Coding rate	Payload size for Sub-Frame 2, 3, 7, 8	Transport block CRC	Number of code blocks per Sub-Frame (Note 1)	Total number of bits per Sub-Frame for Sub-Frame 2, 3, 7, 8	Total symbols per Sub-Frame for Sub-Frame 2, 3, 7, 8	UE Category
Unit	MHz						Bits	Bits		Bits		
	1.4 - 20	1	1	12	16QAM	3/4	408	24	1	576	144	≥ 1
	1.4 - 20	2	1	12	16QAM	3/4	840	24	1	1152	288	≥ 1
	1.4 - 20	3	1	12	16QAM	3/4	1288	24	1	1728	432	≥ 1
	1.4 - 20	4	1	12	16QAM	3/4	1736	24	1	2304	576	≥ 1
	1.4 - 20	5	1	12	16QAM	3/4	2152	24	1	2880	720	≥ 1
	3-20	6	1	12	16QAM	3/4	2600	24	1	3456	864	≥ 1
	3-20	8	1	12	16QAM	3/4	3496	24	1	4608	1152	≥ 1
	3-20	9	1	12	16QAM	3/4	3880	24	1	5184	1296	≥ 1
	3-20	10	1	12	16QAM	3/4	4264	24	1	5760	1440	≥ 1
	3-20	12	1	12	16QAM	3/4	5160	24	1	6912	1728	≥ 1
	5-20	15	1	12	16QAM	1/2	4264	24	1	8640	2160	≥ 1
	5-20	16	1	12	16QAM	1/2	4584	24	1	9216	2304	≥ 1
	5-20	18	1	12	16QAM	1/2	5160	24	1	10368	2592	≥ 1
	5-20	20	1	12	16QAM	1/3	4008	24	1	11520	2880	≥ 1
	5-20	24	1	12	16QAM	1/3	4776	24	1	13824	3456	≥ 1
	10-20	25	1	12	16QAM	1/3	4968	24	1	14400	3600	≥ 1
	10-20	27	1	12	16QAM	1/3	4776	24	1	15552	3888	≥ 1
	10-20	30	1	12	16QAM	3/4	12960	24	3	17280	4320	≥ 2
	10-20	32	1	12	16QAM	3/4	13536	24	3	18432	4608	≥ 2
	10-20	36	1	12	16QAM	3/4	15264	24	3	20736	5184	≥ 2
	10-20	40	1	12	16QAM	3/4	16992	24	3	23040	5760	≥ 2
	10-20	45	1	12	16QAM	3/4	19080	24	4	25920	6480	≥ 2
	10-20	48	1	12	16QAM	3/4	20616	24	4	27648	6912	≥ 2
	15 - 20	50	1	12	16QAM	3/4	21384	24	4	28800	7200	≥ 2
	15 - 20	54	1	12	16QAM	3/4	22920	24	4	31104	7776	≥ 2
	15 - 20	60	1	12	16QAM	2/3	23688	24	4	34560	8640	≥ 2
	15 - 20	64	1	12	16QAM	2/3	25456	24	4	36864	9216	≥ 2
	15 - 20	72	1	12	16QAM	1/2	20616	24	4	41472	10368	≥ 2
	20	75	1	12	16QAM	1/2	21384	24	4	43200	10800	≥ 2
	20	80	1	12	16QAM	1/2	22920	24	4	46080	11520	≥ 2
	20	81	1	12	16QAM	1/2	22920	24	4	46656	11664	≥ 2
	20	90	1	12	16QAM	2/5	20616	24	4	51840	12960	≥ 2
	20	96	1	12	16QAM	2/5	22152	24	4	55296	13824	≥ 2

Note 1: If more than one Code Block is present, an additional CRC sequence of L = 24 Bits is attached to each Code Block (otherwise L = 0 Bit)

Note 2: As per Table 4.2-2 in TS 36.211 [4]

A.2.3.2.3 64-QAM

[FFS]

A.2.3.3 Void

Table A.2.3.3-1: Void

A.3 DL reference measurement channels

A.3.1 General

The number of available channel bits varies across the sub-frames due to PBCH and PSS/SSS overhead. The payload size per sub-frame is varied in order to keep the code rate constant throughout a frame.

No user data is scheduled on subframes #5 in order to facilitate the transmission of system information blocks (SIB).

The algorithm for determining the payload size A is as follows; given a desired coding rate R and radio block allocation N_{RB}

1. Calculate the number of channel bits N_{ch} that can be transmitted during the first transmission of a given sub-frame.
2. Find A such that the resulting coding rate is as close to R as possible, that is,

$$\min |R - (A + 24) / N_{ch}|,$$

subject to

- a) A is a valid TB size according to section 7.1.7 of TS 36.213 [6] assuming an allocation of N_{RB} resource blocks.
 - b) Segmentation is not included in this formula, but should be considered in the TBS calculation.
3. If there is more than one A that minimizes the equation above, then the larger value is chosen per default.
 4. For TDD, the measurement channel is based on DL/UL configuration ratio of 2DL+DwPTS (12 OFDM symbol):
2UL

A.3.1.1 Overview of DL reference measurement channels

In Table A.3.1.1-1 are listed the DL reference measurement channels specified in annexes A.3.2 to A.3.9 of this release of TS 36.101. This table is informative and serves only to a better overview. The reference for the concrete reference measurement channels and corresponding implementation's parameters as to be used for requirements are annexes A.3.2 to A.3.9 as appropriate.

Table A.3.1.1-1: Overview of DL reference measurement channels

Duplex	Table	Name	BW	Mod	TCR	RB	RB Off set	UE Cat eg	Notes
FDD, Receiver requirements									
FDD	Table A.3.2-1		1.4	QPSK	1/3	6		≥ 1	
FDD	Table A.3.2-1		3	QPSK	1/3	15		≥ 1	
FDD	Table A.3.2-1		5	QPSK	1/3	25		≥ 1	
FDD	Table A.3.2-1		10	QPSK	1/3	50		≥ 1	
FDD	Table A.3.2-1		15	QPSK	1/3	75		≥ 1	
FDD	Table A.3.2-1		20	QPSK	1/3	100		≥ 1	
TDD, Receiver requirements									
TDD	Table A.3.2-2		1.4	QPSK	1/3	6		≥ 1	
TDD	Table A.3.2-2		3	QPSK	1/3	15		≥ 1	
TDD	Table A.3.2-2		5	QPSK	1/3	25		≥ 1	
TDD	Table A.3.2-2		10	QPSK	1/3	50		≥ 1	
TDD	Table A.3.2-2		15	QPSK	1/3	75		≥ 1	
TDD	Table A.3.2-2		20	QPSK	1/3	100		≥ 1	
FDD, Receiver requirements, Maximum input level for UE Categories 3-5									
FDD	Table A.3.2-3		1.4	64QAM	3/4	6		-	
FDD	Table A.3.2-3		3	64QAM	3/4	15		-	
FDD	Table A.3.2-3		5	64QAM	3/4	25		-	
FDD	Table A.3.2-3		10	64QAM	3/4	50		-	
FDD	Table A.3.2-3		15	64QAM	3/4	75		-	
FDD	Table A.3.2-3		20	64QAM	3/4	100		-	
FDD, Receiver requirements, Maximum input level for UE Categories 1									
FDD	Table A.3.2-3a		1.4	64QAM	3/4	6		-	
FDD	Table A.3.2-3a		3	64QAM	3/4	15		-	
FDD	Table A.3.2-3a		5	64QAM	3/4	18		-	
FDD	Table A.3.2-3a		10	64QAM	3/4	17		-	
FDD	Table A.3.2-3a		15	64QAM	3/4	17		-	
FDD	Table A.3.2-3a		20	64QAM	3/4	17		-	
FDD, Receiver requirements, Maximum input level for UE Categories 2									
FDD	Table A.3.2-3b		1.4	64QAM	3/4	6		-	
FDD	Table A.3.2-3b		3	64QAM	3/4	15		-	
FDD	Table A.3.2-3b		5	64QAM	3/4	25		-	
FDD	Table A.3.2-3b		10	64QAM	3/4	50		-	
FDD	Table A.3.2-3b		15	64QAM	3/4	75		-	
FDD	Table A.3.2-3b		20	64QAM	3/4	83		-	
TDD, Receiver requirements, Maximum input level for UE Categories 3-5									
TDD	Table A.3.2-4		1.4	64QAM	3/4	6		-	
TDD	Table A.3.2-4		3	64QAM	3/4	15		-	
TDD	Table A.3.2-4		5	64QAM	3/4	25		-	
TDD	Table A.3.2-4		10	64QAM	3/4	50		-	
TDD	Table A.3.2-4		15	64QAM	3/4	75		-	
TDD	Table A.3.2-4		20	64QAM	3/4	100		-	
TDD, Receiver requirements, Maximum input level for UE Categories 1									
TDD	Table A.3.2-4a		1.4	64QAM	3/4	6		-	
TDD	Table A.3.2-4a		3	64QAM	3/4	15		-	

TDD	Table A.3.2-4a		5	64QAM	3/4	18		-	
TDD	Table A.3.2-4a		10	64QAM	3/4	17		-	
TDD	Table A.3.2-4a		15	64QAM	3/4	17		-	
TDD	Table A.3.2-4a		20	64QAM	3/4	17		-	
TDD, Receiver requirements, Maximum input level for UE Categories 2									
TDD	Table A.3.2-4b		1.4	64QAM	3/4	6		-	
TDD	Table A.3.2-4b		3	64QAM	3/4	15		-	
TDD	Table A.3.2-4b		5	64QAM	3/4	25		-	
TDD	Table A.3.2-4b		10	64QAM	3/4	50		-	
TDD	Table A.3.2-4b		15	64QAM	3/4	75		-	
TDD	Table A.3.2-4b		20	64QAM	3/4	83		-	
FDD, PDSCH Performance, Single-antenna transmission (CRS)									
FDD	Table A.3.3.1-1	R.4 FDD	1.4	QPSK	1/3	6		≥ 1	
FDD	Table A.3.3.1-1	R.42 FDD	20	QPSK	1/3	100		≥ 1	
FDD	Table A.3.3.1-1	R.2 FDD	10	QPSK	1/3	50		≥ 1	
FDD	Table A.3.3.1-2	R.3-1 FDD	5	16QAM	1/2	25		≥ 1	
FDD	Table A.3.3.1-2	R.3 FDD	10	16QAM	1/2	50		≥ 2	
FDD	Table A.3.3.1-3	R.5 FDD	3	64QAM	3/4	15		≥ 1	
FDD	Table A.3.3.1-3	R.6 FDD	5	64QAM	3/4	25		≥ 2	
FDD	Table A.3.3.1-3	R.7 FDD	10	64QAM	3/4	50		≥ 2	
FDD	Table A.3.3.1-3	R.8 FDD	15	64QAM	3/4	75		≥ 2	
FDD	Table A.3.3.1-3	R.9 FDD	20	64QAM	3/4	100		≥ 3	
FDD	Table A.3.3.1-3a	R.6-1 FDD	5	64QAM	3/4	18		≥ 1	
FDD	Table A.3.3.1-3a	R.7-1 FDD	10	64QAM	3/4	17		≥ 1	
FDD	Table A.3.3.1-3a	R.8-1 FDD	15	64QAM	3/4	17		≥ 1	
FDD	Table A.3.3.1-3a	R.9-1 FDD	20	64QAM	3/4	17		≥ 1	
FDD	Table A.3.3.1-3a	R.9-2 FDD	20	64QAM	3/4	83		≥ 2	
FDD	Table A.3.3.1-6	R.41 FDD	10	QPSK	1/10	50		≥ 1	
FDD, PDSCH Performance, Single-antenna transmission (CRS), Single PRB (Channel edge)									
FDD	Table A.3.3.1-4	R.0 FDD	3	16QAM	1/2	1		≥ 1	
FDD	Table A.3.3.1-4	R.1 FDD	10 / 20	16QAM	1/2	1		≥ 1	
FDD, PDSCH Performance, Single-antenna transmission (CRS), Single PRB (MBSFN Configuration)									
FDD	Table A.3.3.1-5	R.29 FDD	10	16QAM	1/2	1		≥ 1	
FDD, PDSCH Performance: Carrier aggregation with power imbalance									
FDD	Table A.3.3.1-7	R.49 FDD	20	64QAM	0.84-0.87	100		≥ 5	
FDD, PDSCH Performance, Multi-antenna transmission (CRS), Two antenna ports									
FDD	Table A.3.3.2.1-1	R.10 FDD	10	QPSK	1/3	50		≥ 1	
FDD	Table A.3.3.2.1-1	R.11 FDD	10	16QAM	1/2	50		≥ 2	
FDD	Table A.3.3.2.1-1	R.11-2 FDD	5	16QAM	1/2	25		≥ 1	
FDD	Table A.3.3.2.1-1	R.11-3 FDD	10	16QAM	1/2	40		≥ 1	
FDD	Table A.3.3.2.1-1	R.11-4 FDD	10	QPSK	1/2	50		≥ 1	
FDD	Table A.3.3.2.1-1	R.30 FDD	20	16QAM	1/2	100		≥ 2	
FDD	Table A.3.3.2.1-1	R.35 FDD	10	64QAM	1/2	50		≥ 2	
FDD	Table A.3.3.2.1-1	R.35-1 FDD	20	64QAM	0.39	100		4	
FDD, PDSCH Performance, Multi-antenna transmission (CRS), Four antenna ports									
FDD	Table A.3.3.2.2-1	R.12 FDD	1.4	QPSK	1/3	6		≥ 1	
FDD	Table A.3.3.2.2-1	R.13 FDD	10	QPSK	1/3	50		≥ 1	
FDD	Table A.3.3.2.2-1	R.14 FDD	10	16QAM	1/2	50		≥ 2	

FDD	Table A.3.3.2.2-1	R.14-1 FDD	10	16QAM	1/2	6		≥ 1	
FDD	Table A.3.3.2.2-1	R.14-2 FDD	10	16QAM	1/2	3		≥ 1	
FDD	Table A.3.3.2.2-1	R.14-3 FDD	20	16QAM	1/2	100		≥ 2	
FDD	Table A.3.3.2.2-1	R.36 FDD	10	64QAM	1/2	50		≥ 2	
FDD, PDSCH Performance (UE specific RS) Two antenna ports (CSI-RS)									
FDD	Table A.3.3.3.1-1	R.51 FDD	10	16QAM	1/2	50		≥ 2	
FDD, PDSCH Performance (UE specific RS) Four antenna ports (CSI-RS)									
FDD	Table A.3.3.3.2-1	R.43 FDD	10	QPSK	1/3	50		≥ 1	
FDD	Table A.3.3.3.2-1	R.50 FDD	10	64QAM	1/2	50		≥ 2	
FDD	Table A.3.3.3.2-2	R.44 FDD	10	QPSK	1/3	50		≥ 1	
FDD	Table A.3.3.3.2-2	R.45 FDD	10	16QAM	1/2	50		≥ 2	
FDD	Table A.3.3.3.2-2	R.45-1 FDD	10	16QAM	1/2	39		≥ 1	
TDD, PDSCH Performance, Single-antenna transmission (CRS)									
TDD	Table A.3.4.1-1	R.4 TDD	1.4	QPSK	1/3	6		≥ 1	
TDD	Table A.3.4.1-1	R.42 TDD	20	QPSK	1/3	100		≥ 1	
TDD	Table A.3.4.1-1	R.2 TDD	10	QPSK	1/3	50		≥ 1	
TDD	Table A.3.4.1-2	R.3-1 TDD	5	16QAM	1/2	25		≥ 1	
TDD	Table A.3.4.1-2	R.3 TDD	10	16QAM	1/2	50		≥ 2	
TDD	Table A.3.4.1-3	R.5 TDD	3	64QAM	3/4	15		≥ 1	
TDD	Table A.3.4.1-3	R.6 TDD	5	64QAM	3/4	25		≥ 2	
TDD	Table A.3.4.1-3	R.7 TDD	10	64QAM	3/4	50		≥ 2	
TDD	Table A.3.4.1-3	R.8 TDD	15	64QAM	3/4	75		≥ 2	
TDD	Table A.3.4.1-3	R.9 TDD	20	64QAM	3/4	100		≥ 3	
TDD	Table A.3.4.1-3a	R.6-1 TDD	5	64QAM	3/4	18		≥ 1	
TDD	Table A.3.4.1-3a	R.7-1 TDD	10	64QAM	3/4	17		≥ 1	
TDD	Table A.3.4.1-3a	R.8-1 TDD	15	64QAM	3/4	17		≥ 1	
TDD	Table A.3.4.1-3a	R.9-1 TDD	20	64QAM	3/4	17		≥ 1	
TDD	Table A.3.4.1-3a	R.9-2 TDD	20	64QAM	3/4	83		≥ 2	
TDD	Table A.3.4.1-6	R.41 TDD	10	QPSK	1/10	50		≥ 1	
TDD, PDSCH Performance, Single-antenna transmission (CRS), Single PRB (Channel edge)									
TDD	Table A.3.4.1-4	R.0 TDD	3	16QAM	1/2	1		≥ 1	
TDD	Table A.3.4.1-4	R.1 TDD	10 / 20	16QAM	1/2	1		≥ 1	
TDD, PDSCH Performance, Single-antenna transmission (CRS), Single PRB (MBSFN Configuration)									
TDD	Table A.3.4.1-5	R.29 TDD	10	16QAM	1/2	1		≥ 1	
TDD, PDSCH Performance: Carrier aggregation with power imbalance									
TDD	Table A.3.4.1-7	R.49 TDD	20	64QAM	0.81-087	100		≥ 5	
TDD, PDSCH Performance, Multi-antenna transmission (CRS), Two antenna ports									
TDD	Table A.3.4.2.1-1	R.10 TDD	10	QPSK	1/3	50		≥ 1	
TDD	Table A.3.4.2.1-1	R.11 TDD	10	16QAM	1/2	50		≥ 2	
TDD	Table A.3.4.2.1-1	R.11-1 TDD	10	16QAM	1/2	50		≥ 2	
TDD	Table A.3.4.2.1-1	R.11-2 TDD	5	16QAM	1/2	25		≥ 1	
TDD	Table A.3.4.2.1-1	R.11-3 TDD	10	16QAM	1/2	40		≥ 1	
TDD	Table A.3.4.2.1-1	R.11-4 TDD	10	QPSK	1/2	50		≥ 1	
TDD	Table A.3.4.2.1-1	R.30 TDD	20	16QAM	1/2	100		≥ 2	
TDD	Table A.3.4.2.1-1	R.30-1 TDD	20	16QAM	1/2	100		≥ 2	
TDD	Table A.3.4.2.1-1	R.30-2 TDD	20	16QAM	1/2	100		3	
TDD	Table A.3.4.2.1-1	R.35 TDD	10	64QAM	1/2	50		≥ 2	
TDD	Table A.3.4.2.1-1	R.35-1 TDD	20	64QAM	0.39	100		4	

TDD, PDSCH Performance, Multi-antenna transmission (CRS), Four antenna ports									
TDD	Table A.3.4.2.2-1	R.12 TDD	1.4	QPSK	1/3	6		≥ 1	
TDD	Table A.3.4.2.2-1	R.13 TDD	10	QPSK	1/3	50		≥ 1	
TDD	Table A.3.4.2.2-1	R.14 TDD	10	16QAM	1/2	50		≥ 2	
TDD	Table A.3.4.2.2-1	R.14-1 TDD	10	16QAM	1/2	6		≥ 1	
TDD	Table A.3.4.2.2-1	R.14-2 TDD	10	16QAM	1/2	3		≥ 1	
TDD	Table A.3.4.2.2-1	R.43 TDD	20	16QAM	1/2	100		≥ 2	
TDD	Table A.3.4.2.2-1	R.36 TDD	10	64QAM	1/2	50		≥ 2	
TDD, PDSCH Performance, Single antenna port (DRS)									
TDD	Table A.3.4.3.1-1	R.25 TDD	10	QPSK	1/3	50		≥ 1	
TDD	Table A.3.4.3.1-1	R.26 TDD	10	16QAM	1/2	50		≥ 2	
TDD	Table A.3.4.3.1-1	R.26-1 TDD	5	16QAM	1/2	25		≥ 1	
TDD	Table A.3.4.3.1-1	R.27 TDD	10	64QAM	3/4	50		≥ 2	
TDD	Table A.3.4.3.1-1	R.27-1 TDD	10	64QAM	3/4	18		≥ 1	
TDD	Table A.3.4.3.1-1	R.28 TDD	10	16QAM	1/2	1		≥ 1	
TDD, PDSCH Performance, Two antenna ports (DRS)									
TDD	Table A.3.4.3.2-1	R.31 TDD	10	QPSK	1/3	50		≥ 1	
TDD	Table A.3.4.3.2-1	R.32 TDD	10	16QAM	1/2	50		≥ 2	
TDD	Table A.3.4.3.2-1	R.32-1 TDD	5	16QAM	1/2	[25]		≥ 1	
TDD	Table A.3.4.3.2-1	R.33 TDD	10	64QAM	3/4	50		≥ 2	
TDD	Table A.3.4.3.2-1	R.33-1 TDD	10	64QAM	3/4	[18]		≥ 1	
TDD	Table A.3.4.3.2-1	R.34 TDD	10	64QAM	1/2	50		≥ 2	
TDD, PDSCH Performance (UE specific RS) Two antenna ports (CSI-RS)									
TDD	Table A.3.4.3.3-1	R.51 TDD	10	16QAM	1/2	50		≥ 2	
TDD, PDSCH Performance (UE specific RS) Four antenna ports (CSI-RS)									
TDD	Table A.3.4.3.4-1	R.44 TDD	10	64QAM	1/2	50		≥ 2	
TDD, PDSCH Performance (UE specific RS) Eight antenna ports (CSI-RS)									
TDD	Table A.3.4.3.5-1	R.50 TDD	10	QPSK	1/3	50		≥ 1	
TDD	Table A.3.4.3.5-2	R.45 TDD	10	16QAM	1/2	50		≥ 2	
TDD	Table A.3.4.3.5-2	R.45-1 TDD	10	16QAM	1/2	39		≥ 1	
FDD, PDCCH / PCFICH Performance									
FDD	Table A.3.5.1-1	R.15 FDD	10	PDCCH					
FDD	Table A.3.5.1-1	R.15-1 FDD	10	PDCCH					
FDD	Table A.3.5.1-1	R.16 FDD	10	PDCCH					
FDD	Table A.3.5.1-1	R.17 FDD	5	PDCCH					
TDD, PDCCH / PCFICH Performance									
TDD	Table A.3.5.2-1	R.15 TDD	10	PDCCH					
TDD	Table A.3.5.2-1	R.15-1 TDD	10	PDCCH					
TDD	Table A.3.5.2-1	R.16 TDD	10	PDCCH					
TDD	Table A.3.5.2-1	R.17 TDD	5	PDCCH					
FDD / TDD, PHICH Performance									
FDD / TDD	Table A.3.6-1	R.18	10	PHICH					
FDD / TDD	Table A.3.6-1	R.19	10	PHICH					
FDD / TDD	Table A.3.6-1	R.20	5	PHICH					
FDD / TDD	Table A.3.6-1	R.24	10	PHICH					
FDD / TDD, PBCH Performance									
FDD / TDD	Table A.3.7-1	R.21	1.4	QPSK	40/1920				

FDD / TDD	Table A.3.7-1	R.22	1.4	QPSK	40/1920				
FDD / TDD	Table A.3.7-1	R.23	1.4	QPSK	40/1920				
FDD, PMCH Performance									
FDD	Table A.3.8.1-1	R.40 FDD	1.4	QPSK	1/3	6		≥ 1	
FDD	Table A.3.8.1-1	R.37 FDD	10	QPSK	1/3	50		≥ 1	
FDD	Table A.3.8.1-2	R.38 FDD	10	16QAM	1/2	50		≥ 1	
FDD	Table A.3.8.1-3	R.39-1 FDD	5	64QAM	2/3	25		≥ 1	
FDD	Table A.3.8.1-3	R.39 FDD	10	64QAM	2/3	50		≥ 2	
TDD, PMCH Performance									
TDD	Table A.3.8.2-1	R.40 TDD	1.4	QPSK	1/3	6		≥ 1	
TDD	Table A.3.8.2-1	R.37 TDD	10	QPSK	1/3	50		≥ 1	
TDD	Table A.3.8.2-2	R.38 TDD	10	16QAM	1/2	50		≥ 1	
TDD	Table A.3.8.2-3	R.39-1 TDD	5	64QAM	2/3	25		≥ 1	
TDD	Table A.3.8.2-3	R.39 TDD	10	64QAM	2/3	50		≥ 2	
FDD, Sustained data rate (CRS)									
FDD	Table A.3.9.1-1	R.31-1 FDD	10	64QAM	0.40			≥ 1	
FDD	Table A.3.9.1-1	R.31-2 FDD	10	64QAM	0.59-0.64			≥ 2	
FDD	Table A.3.9.1-1	R.31-3 FDD	20	64QAM	0.59-0.62			≥ 2	
FDD	Table A.3.9.1-1	R.31-3A FDD	10	64QAM	0.85-0.90			≥ 2	
FDD	Table A.3.9.1-1	R.31-3C FDD	15	64QAM	0.87-0.91			≥ 3	
FDD	Table A.3.9.1-1	R.31-4 FDD	20	64QAM	0.87-0.90			≥ 3	
FDD	Table A.3.9.1-1	R.31-4B FDD	15	64QAM	0.85-0.88			≥ 4	
TDD, Sustained data rate (CRS)									
TDD	Table A.3.9.2-1	R.31-1 TDD	10	64QAM	0.40			≥ 1	
TDD	Table A.3.9.2-1	R.31-2 TDD	10	64QAM	0.59-0.64			≥ 2	
TDD	Table A.3.9.2-1	R.31-3 TDD	20	64QAM	0.59-0.62			≥ 2	
TDD	Table A.3.9.2-1	R.31-3A TDD	15	64QAM	0.87-0.90			≥ 2	
TDD	Table A.3.9.2-1	R.31-4 TDD	20	64QAM	0.87-0.90			≥ 3	

A.3.2 Reference measurement channel for receiver characteristics

Tables A.3.2-1 and A.3.2-2 are applicable for measurements on the Receiver Characteristics (clause 7) with the exception of sub-clause 7.4 (Maximum input level).

Tables A.3.2-3, A.3.2-3a, A.3.2-3b, A.3.2-4, A.3.2-4a and A.3.2-4b are applicable for sub-clause 7.4 (Maximum input level).

Tables A.3.2-1 and A.3.2-2 also apply for the modulated interferer used in Clauses 7.5, 7.6 and 7.8 with test specific bandwidths.

Table A.3.2-1 Fixed Reference Channel for Receiver Requirements (FDD)

Parameter	Unit	Value					
		1.4	3	5	10	15	20
Channel bandwidth	MHz	1.4	3	5	10	15	20
Allocated resource blocks		6	15	25	50	75	100
Subcarriers per resource block		12	12	12	12	12	12
Allocated subframes per Radio Frame		9	9	9	9	9	9
Modulation		QPSK	QPSK	QPSK	QPSK	QPSK	QPSK
Target Coding Rate		1/3	1/3	1/3	1/3	1/3	1/3
Number of HARQ Processes	Processes	8	8	8	8	8	8
Maximum number of HARQ transmissions		1	1	1	1	1	1
Information Bit Payload per Sub-Frame							
For Sub-Frames 1,2,3,4,6,7,8,9	Bits	408	1320	2216	4392	6712	8760
For Sub-Frame 5	Bits	n/a	n/a	n/a	n/a	n/a	n/a
For Sub-Frame 0	Bits	152	872	1800	4392	6712	8760
Transport block CRC	Bits	24	24	24	24	24	24
Number of Code Blocks per Sub-Frame (Note 3)							
For Sub-Frames 1,2,3,4,6,7,8,9	Bits	1	1	1	1	2	2
For Sub-Frame 5	Bits	n/a	n/a	n/a	n/a	n/a	n/a
For Sub-Frame 0	Bits	1	1	1	1	2	2
Binary Channel Bits Per Sub-Frame							
For Sub-Frames 1,2,3,4,6,7,8,9	Bits	1368	3780	6300	13800	20700	27600
For Sub-Frame 5	Bits	n/a	n/a	n/a	n/a	n/a	n/a
For Sub-Frame 0	Bits	528	2940	5460	12960	19860	26760
Max. Throughput averaged over 1 frame	kbps	341.6	1143. 2	1952. 8	3952. 8	6040. 8	7884
UE Category		≥ 1	≥ 1	≥ 1	≥ 1	≥ 1	≥ 1
Note 1:	2 symbols allocated to PDCCH for 20 MHz, 15 MHz and 10MHz channel BW. 3 symbols allocated to PDCCH for 5 MHz and 3 MHz. 4 symbols allocated to PDCCH for 1.4 MHz						
Note 2:	Reference signal, Synchronization signals and PBCH allocated as per TS 36.211 [4]						
Note 3:	If more than one Code Block is present, an additional CRC sequence of L = 24 Bits is attached to each Code Block (otherwise L = 0 Bit)						

Table A.3.2-2 Fixed Reference Channel for Receiver Requirements (TDD)

Parameter	Unit	Value					
		1.4	3	5	10	15	20
Channel Bandwidth	MHz	1.4	3	5	10	15	20
Allocated resource blocks		6	15	25	50	75	100
Uplink-Downlink Configuration (Note 5)		1	1	1	1	1	1
Allocated subframes per Radio Frame (D+S)		3	3+2	3+2	3+2	3+2	3+2
Number of HARQ Processes	Processes	7	7	7	7	7	7
Maximum number of HARQ transmission		1	1	1	1	1	1
Modulation		QPSK	QPSK	QPSK	QPSK	QPSK	QPSK
Target coding rate		1/3	1/3	1/3	1/3	1/3	1/3
Information Bit Payload per Sub-Frame	Bits						
For Sub-Frame 4, 9		408	1320	2216	4392	6712	8760
For Sub-Frame 1, 6		n/a	968	1544	3240	4968	6712
For Sub-Frame 5		n/a	n/a	n/a	n/a	n/a	n/a
For Sub-Frame 0		208	1064	1800	4392	6712	8760
Transport block CRC	Bits	24	24	24	24	24	24
Number of Code Blocks per Sub-Frame (Note 4)							
For Sub-Frame 4, 9		1	1	1	1	2	2
For Sub-Frame 1, 6		n/a	1	1	1	1	2
For Sub-Frame 5		n/a	n/a	n/a	n/a	n/a	n/a
For Sub-Frame 0		1	1	1	1	2	2
Binary Channel Bits Per Sub-Frame	Bits						
For Sub-Frame 4, 9		1368	3780	6300	13800	20700	27600
For Sub-Frame 1, 6		n/a	3276	5556	11256	16956	22656
For Sub-Frame 5		n/a	n/a	n/a	n/a	n/a	n/a
For Sub-Frame 0		672	3084	5604	13104	20004	26904
Max. Throughput averaged over 1 frame	kbps	102.4	564	932	1965.6	3007.2	3970.4
UE Category		≥ 1	≥ 1	≥ 1	≥ 1	≥ 1	≥ 1
Note 1:	For normal subframes(0,4,5,9), 2 symbols allocated to PDCCH for 20 MHz, 15 MHz and 10 MHz channel BW; 3 symbols allocated to PDCCH for 5 MHz and 3 MHz; 4 symbols allocated to PDCCH for 1.4 MHz. For special subframe (1&6), only 2 OFDM symbols are allocated to PDCCH for all BWs.						
Note 2:	For 1.4MHz, no data shall be scheduled on special subframes(1&6) to avoid problems with insufficient PDCCH performance						
Note 3:	Reference signal, Synchronization signals and PBCH allocated as per TS 36.211 [4]						
Note 4:	If more than one Code Block is present, an additional CRC sequence of L = 24 Bits is attached to each Code Block (otherwise L = 0 Bit).						
Note 5:	As per Table 4.2-2 in TS 36.211 [4]						

Table A.3.2-3 Fixed Reference Channel for Maximum input level for UE Categories 3-8 (FDD)

Parameter	Unit	Value					
		1.4	3	5	10	15	20
Channel bandwidth	MHz	1.4	3	5	10	15	20
Allocated resource blocks		6	15	25	50	75	100
Subcarriers per resource block		12	12	12	12	12	12
Allocated subframes per Radio Frame		8	9	9	9	9	9
Modulation		64QAM	64QAM	64QAM	64QAM	64QAM	64QAM
Target Coding Rate		3/4	3/4	3/4	3/4	3/4	3/4
Number of HARQ Processes	Processes	8	8	8	8	8	8
Maximum number of HARQ transmissions		1	1	1	1	1	1
Information Bit Payload per Sub-Frame							
For Sub-Frames 1,2,3,4,6,7,8,9	Bits	2984	8504	14112	30576	46888	61664
For Sub-Frame 5	Bits	n/a	n/a	n/a	n/a	n/a	n/a
For Sub-Frame 0	Bits	n/a	6456	12576	28336	45352	61664
Transport block CRC	Bits	24	24	24	24	24	24
Number of Code Blocks per Sub-Frame (Note 3)							
For Sub-Frames 1,2,3,4,6,7,8,9		1	2	3	5	8	11
For Sub-Frame 5		n/a	n/a	n/a	n/a	n/a	n/a
For Sub-Frame 0		n/a	2	3	5	8	11
Binary Channel Bits Per Sub-Frame							
For Sub-Frames 1,2,3,4,6,7,8,9	Bits	4104	11340	18900	41400	62100	82800
For Sub-Frame 5	Bits	n/a	n/a	n/a	n/a	n/a	n/a
For Sub-Frame 0	Bits	n/a	8820	16380	38880	59580	80280
Max. Throughput averaged over 1 frame	kbps	2387.2	7448.8	12547	27294	42046	55498
Note 1:	2 symbols allocated to PDCCH for 20 MHz, 15 MHz and 10 MHz channel BW. 3 symbols allocated to PDCCH for 5 MHz and 3 MHz. 4 symbols allocated to PDCCH for 1.4 MHz.						
Note 2:	Reference signal, Synchronization signals and PBCH allocated as per TS 36.211 [4].						
Note 3:	If more than one Code Block is present, an additional CRC sequence of L = 24 Bits is attached to each Code Block (otherwise L = 0 Bit).						

Table A.3.2-3a Fixed Reference Channel for Maximum input level for UE Category 1 (FDD)

Parameter	Unit	Value					
		1.4	3	5	10	15	20
Channel bandwidth	MHz	1.4	3	5	10	15	20
Allocated resource blocks		6	15	18	17	17	17
Subcarriers per resource block		12	12	12	12	12	12
Allocated subframes per Radio Frame		8	9	9	9	9	9
Modulation		64QAM	64QAM	64QAM	64QAM	64QAM	64QAM
Target Coding Rate		3/4	3/4	3/4	3/4	3/4	3/4
Number of HARQ Processes	Processes	8	8	8	8	8	8
Maximum number of HARQ transmissions		1	1	1	1	1	1
Information Bit Payload							
For Sub-Frames 1,2,3,4,6,7,8,9	Bits	2984	8504	10296	10296	10296	10296
For Sub-Frame 5	Bits	n/a	n/a	n/a	n/a	n/a	n/a
For Sub-Frame 0	Bits	n/a	6456	8248	10296	10296	10296
Transport block CRC	Bits	24	24	24	24	24	24
Number of Code Blocks per Sub-Frame (Note 3)							
For Sub-Frames 1,2,3,4,6,7,8,9		1	2	2	2	2	2
For Sub-Frame 5		n/a	n/a	n/a	n/a	n/a	n/a
For Sub-Frame 0		n/a	2	2	2	2	2
Binary Channel Bits Per Sub-Frame							
For Sub-Frames 1,2,3,4,6,7,8,9	Bits	4104	11340	13608	14076	14076	14076
For Sub-Frame 5	Bits	n/a	n/a	n/a	n/a	n/a	n/a
For Sub-Frame 0	Bits	n/a	8820	11088	14076	14076	14076
Max. Throughput averaged over 1 frame	kbps	2387.2	7448.8	9079.6	9266.4	9266.4	9266.4
Note 1:	2 symbols allocated to PDCCH for 20 MHz, 15 MHz and 10 MHz channel BW. 3 symbols allocated to PDCCH for 5 MHz and 3 MHz. 4 symbols allocated to PDCCH for 1.4 MHz.						
Note 2:	Reference signal, Synchronization signals and PBCH allocated as per TS 36.211 [4].						
Note 3:	If more than one Code Block is present, an additional CRC sequence of L = 24 Bits is attached to each Code Block (otherwise L = 0 Bit).						

Table A.3.2-3b Fixed Reference Channel for Maximum input level for UE Category 2 (FDD)

Parameter	Unit	Value					
		1.4	3	5	10	15	20
Channel bandwidth	MHz	1.4	3	5	10	15	20
Allocated resource blocks		6	15	25	50	75	83
Subcarriers per resource block		12	12	12	12	12	12
Allocated subframes per Radio Frame		8	9	9	9	9	9
Modulation		64QAM	64QAM	64QAM	64QAM	64QAM	64QAM
Target Coding Rate		3/4	3/4	3/4	3/4	3/4	3/4
Number of HARQ Processes	Processes	8	8	8	8	8	8
Maximum number of HARQ transmissions		1	1	1	1	1	1
Information Bit Payload							
For Sub-Frames 1,2,3,4,6,7,8,9	Bits	2984	8504	14112	30576	46888	51024
For Sub-Frame 5	Bits	n/a	n/a	n/a	n/a	n/a	n/a
For Sub-Frame 0	Bits	n/a	6456	12576	28336	45352	51024
Transport block CRC	Bits	24	24	24	24	24	24
Number of Code Blocks per Sub-Frame (Note 3)							
For Sub-Frames 1,2,3,4,6,7,8,9		1	2	3	5	8	9
For Sub-Frame 5		n/a	n/a	n/a	n/a	n/a	n/a
For Sub-Frame 0		n/a	2	3	5	8	9
Binary Channel Bits Per Sub-Frame							
For Sub-Frames 1,2,3,4,6,7,8,9	Bits	4104	11340	18900	41400	62100	68724
For Sub-Frame 5	Bits	n/a	n/a	n/a	n/a	n/a	n/a
For Sub-Frame 0	Bits	n/a	8820	16380	38880	59580	66204
Max. Throughput averaged over 1 frame	kbps	2387.2	7448.8	12547	27294	42046	45922
Note 1:	2 symbols allocated to PDCCH for 20 MHz, 15 MHz and 10 MHz channel BW. 3 symbols allocated to PDCCH for 5 MHz and 3 MHz. 4 symbols allocated to PDCCH for 1.4 MHz.						
Note 2:	Reference signal, Synchronization signals and PBCH allocated as per TS 36.211 [4].						
Note 3:	If more than one Code Block is present, an additional CRC sequence of L = 24 Bits is attached to each Code Block (otherwise L = 0 Bit).						

Table A.3.2-4 Fixed Reference Channel for Maximum input level for UE Categories 3-8 (TDD)

Parameter	Unit	Value					
		1.4	3	5	10	15	20
Channel bandwidth	MHz	1.4	3	5	10	15	20
Allocated resource blocks		6	15	25	50	75	100
Subcarriers per resource block		12	12	12	12	12	12
Uplink-Downlink Configuration (Note 5)		1	1	1	1	1	1
Allocated subframes per Radio Frame		2	3+2	3+2	3+2	3+2	3+2
Modulation		64QAM	64QAM	64QAM	64QAM	64QAM	64QAM
Target Coding Rate		3/4	3/4	3/4	3/4	3/4	3/4
Number of HARQ Processes	Processes	7	7	7	7	7	7
Maximum number of HARQ transmissions		1	1	1	1	1	1
Information Bit Payload per Sub-Frame							
For Sub-Frames 4,9	Bits	2984	8504	14112	30576	46888	61664
For Sub-Frames 1,6	Bits	n/a	6968	11448	23688	35160	46888
For Sub-Frame 5	Bits	n/a	n/a	n/a	n/a	n/a	n/a
For Sub-Frame 0	Bits	n/a	6968	12576	30576	45352	61664
Transport block CRC	Bits	24	24	24	24	24	24
Number of Code Blocks per Sub-Frame (Note 4)							
For Sub-Frames 4,9		1	2	3	5	8	11
For Sub-Frames 1,6		n/a	2	2	4	6	8
For Sub-Frame 5		n/a	n/a	n/a	n/a	n/a	n/a
For Sub-Frame 0		n/a	2	3	5	8	11
Binary Channel Bits per Sub-Frame							
For Sub-Frames 4,9	Bits	4104	11340	18900	41400	62100	82800
For Sub-Frames 1,6		n/a	9828	16668	33768	50868	67968
For Sub-Frame 5	Bits	n/a	n/a	n/a	n/a	n/a	n/a
For Sub-Frame 0	Bits	n/a	9252	16812	39312	60012	80712
Max. Throughput averaged over 1 frame	kbps	596.8	3791.2	6369.6	13910	20945	27877
Note 1:	For normal subframes(0,4,5,9), 2 symbols allocated to PDCCH for 20 MHz, 15 MHz and 10 MHz channel BW; 3 symbols allocated to PDCCH for 5 MHz and 3 MHz; 4 symbols allocated to PDCCH for 1.4 MHz. For special subframe (1&6), only 2 OFDM symbols are allocated to PDCCH for all BWs.						
Note 2:	For 1.4MHz, no data shall be scheduled on special subframes(1&6) to avoid problems with insufficient PDCCH performance.						
Note 3:	Reference signal, Synchronization signals and PBCH allocated as per TS 36.211 [4].						
Note 4:	If more than one Code Block is present, an additional CRC sequence of L = 24 Bits is attached to each Code Block (otherwise L = 0 Bit).						
Note 5:	As per Table 4.2-2 in TS 36.211 [4].						

Table A.3.2-4a Fixed Reference Channel for Maximum input level for UE Category 1 (TDD)

Parameter	Unit	Value					
		1.4	3	5	10	15	20
Channel bandwidth	MHz	1.4	3	5	10	15	20
Allocated resource blocks		6	15	18	17	17	17
Subcarriers per resource block		12	12	12	12	12	12
Uplink-Downlink Configuration (Note 5)		1	1	1	1	1	1
Allocated subframes per Radio Frame		2	3+2	3+2	3+2	3+2	3+2
Modulation		64QAM	64QAM	64QAM	64QAM	64QAM	64QAM
Target Coding Rate		3/4	3/4	3/4	3/4	3/4	3/4
Number of HARQ Processes	Processes	7	7	7	7	7	7
Maximum number of HARQ transmissions		1	1	1	1	1	1
Information Bit Payload per Sub-Frame							
For Sub-Frames 4,9	Bits	2984	8504	10296	10296	10296	10296
For Sub-Frames 1,6	Bits	n/a	6968	8248	7480	7480	7480
For Sub-Frame 5	Bits	n/a	n/a	n/a	n/a	n/a	n/a
For Sub-Frame 0	Bits	n/a	6968	8248	10296	10296	10296
Transport block CRC	Bits	24	24	24	24	24	24
Number of Code Blocks per Sub-Frame (Note 4)							
For Sub-Frames 4,9		1	2	2	2	2	2
For Sub-Frames 1,6		n/a	2	2	2	2	2
For Sub-Frame 5		n/a	n/a	n/a	n/a	n/a	n/a
For Sub-Frame 0		n/a	2	2	2	2	2
Binary Channel Bits per Sub-Frame							
For Sub-Frames 4,9	Bits	4104	11340	13608	14076	14076	14076
For Sub-Frames 1,6		n/a	9828	11880	11628	11628	11628
For Sub-Frame 5	Bits	n/a	n/a	n/a	n/a	n/a	n/a
For Sub-Frame 0	Bits	n/a	9252	11520	14076	14076	14076
Max. Throughput averaged over 1 frame	kbps	596.8	3791.2	4533.6	4584.8	4584.8	4584.8
Note 1:	For normal subframes(0,4,5,9), 2 symbols allocated to PDCCH for 20 MHz, 15 MHz and 10 MHz channel BW; 3 symbols allocated to PDCCH for 5 MHz and 3 MHz; 4 symbols allocated to PDCCH for 1.4 MHz. For special subframe (1&6), only 2 OFDM symbols are allocated to PDCCH for all BWs.						
Note 2:	For 1.4MHz, no data shall be scheduled on special subframes(1&6) to avoid problems with insufficient PDCCH performance.						
Note 3:	Reference signal, Synchronization signals and PBCH allocated as per TS 36.211 [4].						
Note 4:	If more than one Code Block is present, an additional CRC sequence of L = 24 Bits is attached to each Code Block (otherwise L = 0 Bit).						
Note 5:	As per Table 4.2-2 in TS 36.211 [4].						

Table A.3.2-4b Fixed Reference Channel for Maximum input level for UE Category 2 (TDD)

Parameter	Unit	Value					
		1.4	3	5	10	15	20
Channel bandwidth	MHz	1.4	3	5	10	15	20
Allocated resource blocks		6	15	25	50	75	83
Subcarriers per resource block		12	12	12	12	12	12
Uplink-Downlink Configuration (Note 5)		1	1	1	1	1	1
Allocated subframes per Radio Frame		2	3+2	3+2	3+2	3+2	3+2
Modulation		64QAM	64QAM	64QAM	64QAM	64QAM	64QAM
Target Coding Rate		3/4	3/4	3/4	3/4	3/4	3/4
Number of HARQ Processes	Processes	7	7	7	7	7	7
Maximum number of HARQ transmissions		1	1	1	1	1	1
Information Bit Payload per Sub-Frame							
For Sub-Frames 4,9	Bits	2984	8504	14112	30576	46888	51024
For Sub-Frames 1,6	Bits	n/a	6968	11448	23688	35160	39232
For Sub-Frame 5	Bits	n/a	n/a	n/a	n/a	n/a	n/a
For Sub-Frame 0	Bits	n/a	6968	12576	30576	45352	51024
Transport block CRC	Bits	24	24	24	24	24	24
Number of Code Blocks per Sub-Frame (Note 4)							
For Sub-Frames 4,9		1	2	3	5	8	9
For Sub-Frames 1,6		n/a	2	3	5	7	7
For Sub-Frame 5		n/a	n/a	n/a	n/a	n/a	n/a
For Sub-Frame 0		n/a	2	3	5	8	9
Binary Channel Bits per Sub-Frame							
For Sub-Frames 4,9	Bits	4104	11340	18900	41400	62100	68724
For Sub-Frames 1,6		n/a	9828	16668	33768	50868	56340
For Sub-Frame 5	Bits	n/a	n/a	n/a	n/a	n/a	n/a
For Sub-Frame 0	Bits	n/a	9252	16380	39312	60012	66636
Max. Throughput averaged over 1 frame	kbps	596.8	3791.2	6369.6	13910	20945	23154
Note 1:	For normal subframes(0,4,5,9), 2 symbols allocated to PDCCH for 20 MHz, 15 MHz and 10 MHz channel BW; 3 symbols allocated to PDCCH for 5 MHz and 3 MHz; 4 symbols allocated to PDCCH for 1.4 MHz. For special subframe (1&6), only 2 OFDM symbols are allocated to PDCCH for all BWs.						
Note 2:	For 1.4MHz, no data shall be scheduled on special subframes(1&6) to avoid problems with insufficient PDCCH performance.						
Note 3:	Reference signal, Synchronization signals and PBCH allocated as per TS 36.211 [4].						
Note 4:	If more than one Code Block is present, an additional CRC sequence of L = 24 Bits is attached to each Code Block (otherwise L = 0 Bit).						
Note 5:	As per Table 4.2-2 in TS 36.211 [4].						

A.3.3 Reference measurement channels for PDSCH performance requirements (FDD)

A.3.3.1 Single-antenna transmission (Common Reference Symbols)

Table A.3.3.1-1: Fixed Reference Channel QPSK R=1/3

Parameter	Unit	Value					
		R.4 FDD	R.42 FDD		R.2 FDD		
Reference channel							
Channel bandwidth	MHz	1.4	20		10		
Allocated resource blocks (Note 4)		6	100		50		
Allocated subframes per Radio Frame		9	9		9		
Modulation		QPSK	QPSK		QPSK		
Target Coding Rate		1/3	1/3		1/3		
Information Bit Payload (Note 4)							
For Sub-Frames 1,2,3,4,6,7,8,9	Bits	408	8760		4392		
For Sub-Frame 5	Bits	n/a	n/a		n/a		
For Sub-Frame 0	Bits	152	8760		4392		
Number of Code Blocks (Notes 3 and 4)							
For Sub-Frames 1,2,3,4,6,7,8,9		1	2		1		
For Sub-Frame 5		n/a	n/a		n/a		
For Sub-Frame 0		1	2		1		
Binary Channel Bits (Note 4)							
For Sub-Frames 1,2,3,4,6,7,8,9	Bits	1368	27600		13800		
For Sub-Frame 5	Bits	n/a	n/a		n/a		
For Sub-Frame 0	Bits	528	26760		12960		
Max. Throughput averaged over 1 frame (Note 4)	Mbps	0.342	7.884		3.953		
UE Category		≥ 1	≥ 1		≥ 1		
Note 1: 2 symbols allocated to PDCCH for 20 MHz, 15 MHz and 10 MHz channel BW; 3 symbols allocated to PDCCH for 5 MHz and 3 MHz; 4 symbols allocated to PDCCH for 1.4 MHz. Note 2: Reference signal, synchronization signals and PBCH allocated as per TS 36.211 [4]. Note 3: If more than one Code Block is present, an additional CRC sequence of L = 24 Bits is attached to each Code Block (otherwise L = 0 Bit). Note 4: Given per component carrier per codeword.							

Table A.3.3.1-2: Fixed Reference Channel 16QAM R=1/2

Parameter	Unit	Value					
				R.3-1 FDD	R.3 FDD		
Reference channel							
Channel bandwidth	MHz	1.4	3	5	10	15	20
Allocated resource blocks				25	50		
Allocated subframes per Radio Frame				9	9		
Modulation				16QAM	16QAM		
Target Coding Rate				1/2	1/2		
Information Bit Payload							
For Sub-Frames 1,2,3,4,6,7,8,9	Bits			6456	14112		
For Sub-Frame 5	Bits			n/a	n/a		
For Sub-Frame 0	Bits			5736	12960		
Number of Code Blocks per Sub-Frame (Note 3)							
For Sub-Frames 1,2,3,4,6,7,8,9				2	3		
For Sub-Frame 5				n/a	n/a		
For Sub-Frame 0				1	3		
Binary Channel Bits Per Sub-Frame							
For Sub-Frames 1,2,3,4,6,7,8,9	Bits			12600	27600		
For Sub-Frame 5	Bits			n/a	n/a		
For Sub-Frame 0	Bits			10920	25920		
Max. Throughput averaged over 1 frame	Mbps			5.738	12.586		
UE Category				≥ 1	≥ 2		
Note 1: 2 symbols allocated to PDCCH for 20 MHz, 15 MHz and 10 MHz channel BW; 3 symbols allocated to PDCCH for 5 MHz and 3 MHz; 4 symbols allocated to PDCCH for 1.4 MHz. Note 2: Reference signal, synchronization signals and PBCH allocated as per TS 36.211 [4]. Note 3: If more than one Code Block is present, an additional CRC sequence of L = 24 Bits is attached to each Code Block (otherwise L = 0 Bit).							

Table A.3.3.1-3: Fixed Reference Channel 64QAM R=3/4

Parameter	Unit	Value					
			R.5 FDD	R.6 FDD	R.7 FDD	R.8 FDD	R.9 FDD
Reference channel							
Channel bandwidth	MHz	1.4	3	5	10	15	20
Allocated resource blocks			15	25	50	75	100
Allocated subframes per Radio Frame			9	9	9	9	9
Modulation		64QAM	64QAM	64QAM	64QAM	64QAM	64QAM
Target Coding Rate		3/4	3/4	3/4	3/4	3/4	3/4
Information Bit Payload							
For Sub-Frames 1,2,3,4,6,7,8,9	Bits		8504	14112	30576	46888	61664
For Sub-Frame 5	Bits		n/a	n/a	n/a	n/a	n/a
For Sub-Frame 0	Bits		6456	12576	28336	45352	61664
Number of Code Blocks per Sub-Frame (Note 3)							
For Sub-Frames 1,2,3,4,6,7,8,9			2	3	5	8	11
For Sub-Frame 5			n/a	n/a	n/a	n/a	n/a
For Sub-Frame 0			2	3	5	8	11
Binary Channel Bits Per Sub-Frame							
For Sub-Frames 1,2,3,4,6,7,8,9	Bits		11340	18900	41400	62100	82800
For Sub-Frame 5	Bits		n/a	n/a	n/a	n/a	n/a
For Sub-Frame 0	Bits		8820	16380	38880	59580	80280
Max. Throughput averaged over 1 frame	Mbps		7.449	12.547	27.294	42.046	55.498
UE Category			≥ 1	≥ 2	≥ 2	≥ 2	≥ 3
Note 1: 2 symbols allocated to PDCCH for 20 MHz, 15 MHz and 10 MHz channel BW; 3 symbols allocated to PDCCH for 5 MHz and 3 MHz; 4 symbols allocated to PDCCH for 1.4 MHz. Note 2: Reference signal, synchronization signals and PBCH allocated as per TS 36.211 [4]. Note 3: If more than one Code Block is present, an additional CRC sequence of L = 24 Bits is attached to each Code Block (otherwise L = 0 Bit).							

Table A.3.3.1-3a: Fixed Reference Channel 64QAM R=3/4

Parameter	Unit	Value				
		R.6-1 FDD	R.7-1 FDD	R.8-1 FDD	R.9-1 FDD	R.9-2 FDD
Reference channel						
Channel bandwidth	MHz	5	10	15	20	20
Allocated resource blocks (Note 3)		18	17	17	17	83
Allocated subframes per Radio Frame		9	9	9	9	9
Modulation		64QAM	64QAM	64QAM	64QAM	64QAM
Target Coding Rate		3/4	3/4	3/4	3/4	3/4
Information Bit Payload						
For Sub-Frames 1,2,3,4,6,7,8,9	Bits	10296	10296	10296	10296	51024
For Sub-Frame 5	Bits	n/a	n/a	n/a	n/a	n/a
For Sub-Frame 0	Bits	8248	10296	10296	10296	51024
Number of Code Blocks per Sub-Frame (Note 4)						
For Sub-Frames 1,2,3,4,6,7,8,9		2	2	2	2	9
For Sub-Frame 5		n/a	n/a	n/a	n/a	n/a
For Sub-Frame 0		2	2	2	2	9
Binary Channel Bits Per Sub-Frame						
For Sub-Frames 1,2,3,4,6,7,8,9	Bits	13608	14076	14076	14076	68724
For Sub-Frame 5	Bits	n/a	n/a	n/a	n/a	n/a
For Sub-Frame 0	Bits	11088	14076	14076	14076	66204
Max. Throughput averaged over 1 frame	Mbps	9.062	9.266	9.266	9.266	45.922
UE Category		≥ 1	≥ 1	≥ 1	≥ 1	≥ 2
Note 1:	2 symbols allocated to PDCCH for 20 MHz, 15 MHz and 10 MHz channel BW; 3 symbols allocated to PDCCH for 5 MHz and 3 MHz; 4 symbols allocated to PDCCH for 1.4 MHz.					
Note 2:	Reference signal, synchronization signals and PBCH allocated as per TS 36.211 [4].					
Note 3:	Localized allocation started from RB #0 is applied.					
Note 4:	If more than one Code Block is present, an additional CRC sequence of L = 24 Bits is attached to each Code Block (otherwise L = 0 Bit).					

Table A.3.3.1-4: Fixed Reference Channel Single PRB (Channel Edge)

Parameter	Unit	Value					
		R.0 FDD		R.1 FDD			
Reference channel							
Channel bandwidth	MHz	1.4	3	5	10/20	15	20
Allocated resource blocks			1		1		
Allocated subframes per Radio Frame			9		9		
Modulation			16QAM		16QAM		
Target Coding Rate			1/2		1/2		
Information Bit Payload							
For Sub-Frames 1,2,3,4,6,7,8,9	Bits		224		256		
For Sub-Frame 5	Bits		n/a		n/a		
For Sub-Frame 0	Bits		224		256		
Number of Code Blocks per Sub-Frame (Note 3)							
For Sub-Frames 1,2,3,4,6,7,8,9			1		1		
For Sub-Frame 5			n/a		n/a		
For Sub-Frame 0			1		1		
Binary Channel Bits Per Sub-Frame							
For Sub-Frames 1,2,3,4,6,7,8,9	Bits		504		552		
For Sub-Frame 5	Bits		n/a		n/a		
For Sub-Frame 0	Bits		504		552		
Max. Throughput averaged over 1 frame	Mbps		0.202		0.230		
UE Category			≥ 1		≥ 1		
Note 1:	2 symbols allocated to PDCCH for 20 MHz, 15 MHz and 10 MHz channel BW; 3 symbols allocated to PDCCH for 5 MHz and 3 MHz; 4 symbols allocated to PDCCH for 1.4 MHz.						
Note 2:	Reference signal, synchronization signals and PBCH allocated as per TS 36.211 [4].						
Note 3:	If more than one Code Block is present, an additional CRC sequence of L = 24 Bits is attached to each Code Block (otherwise L = 0 Bit).						

Table A.3.3.1-5: Fixed Reference Channel Single PRB (MBSFN Configuration)

Parameter	Unit	Value
Reference channel		R.29 FDD (MBSFN)
Channel bandwidth	MHz	10
Allocated resource blocks		1
MBSFN Configuration (Note 3)		111111
Allocated subframes per Radio Frame		3
Modulation		16QAM
Target Coding Rate		1/2
Information Bit Payload		
For Sub-Frames 4,9	Bits	256
For Sub-Frame 5	Bits	n/a
For Sub-Frame 0	Bits	256
For Sub-Frame 1,2,3,6,7,8	Bits	0 (MBSFN)
Number of Code Blocks per Sub-Frame (Note 4)		
For Sub-Frames 4,9		1
For Sub-Frame 5		n/a
For Sub-Frame 0		1
For Sub-Frame 1,2,3,6,7,8		0 (MBSFN)
Binary Channel Bits Per Sub-Frame		
For Sub-Frames 4,9	Bits	552
For Sub-Frame 5	Bits	n/a
For Sub-Frame 0	Bits	552
For Sub-Frame 1,2,3,6,7,8	Bits	0 (MBSFN)
Max. Throughput averaged over 1 frame	kbps	76.8
UE Category		≥ 1
Note 1:	2 symbols allocated to PDCCH.	
Note 2:	Reference signal, synchronization signals and PBCH allocated as per TS 36.211 [4].	
Note 3:	MBSFN Subframe Allocation as defined in [7], one frame with 6 bits is chosen for MBSFN subframe allocation.	
Note 4:	If more than one Code Block is present, an additional CRC sequence of L = 24 Bits is attached to each Code Block (otherwise L = 0 Bit).	

Table A.3.3.1-6: Fixed Reference Channel QPSK R=1/10

Parameter	Unit	Value					
					R.41 FDD		
Reference channel							
Channel bandwidth	MHz	1.4	3	5	10	15	20
Allocated resource blocks					50		
Allocated subframes per Radio Frame					9		
Modulation					QPSK		
Target Coding Rate					1/10		
Information Bit Payload							
For Sub-Frames 1,2,3,4,6,7,8,9	Bits				1384		
For Sub-Frame 5	Bits				n/a		
For Sub-Frame 0	Bits				1384		
Number of Code Blocks per Sub-Frame (Note 3)							
For Sub-Frames 1,2,3,4,6,7,8,9					1		
For Sub-Frame 5					n/a		
For Sub-Frame 0					1		
Binary Channel Bits Per Sub-Frame							
For Sub-Frames 1,2,3,4,6,7,8,9	Bits				13800		
For Sub-Frame 5	Bits				n/a		
For Sub-Frame 0	Bits				12960		
Max. Throughput averaged over 1 frame	Mbps				1.246		
UE Category					≥ 1		
<p>Note 1: 2 symbols allocated to PDCCH for 20 MHz, 15 MHz and 10 MHz channel BW; 3 symbols allocated to PDCCH for 5 MHz and 3 MHz; 4 symbols allocated to PDCCH for 1.4 MHz.</p> <p>Note 2: Reference signal, synchronization signals and PBCH allocated as per TS 36.211 [4].</p> <p>Note 3: If more than one Code Block is present, an additional CRC sequence of L = 24 Bits is attached to each Code Block (otherwise L = 0 Bit).</p>							

Table A.3.3.1-7: PCell Fixed Reference Channel for CA demodulation with power imbalance

Parameter	Unit	Value
Reference channel		R.49 FDD
Channel bandwidth	MHz	20
Allocated resource blocks		100
Allocated subframes per Radio Frame		9
Modulation		64QAM
Coding Rate		
For Sub-Frame 1,2,3,4,6,7,8,9,		0.84
For Sub-Frame 5		N/A
For Sub-Frame 0		0.87
Information Bit Payload		
For Sub-Frames 0,1,2,3,4,6,7,8,9	Bits	63776
For Sub-Frame 5	Bits	N/A
Number of Code Blocks per Sub-Frame (Note 3)		
For Sub-Frames 0,1,2,3,4,6,7,8,9	Code Blocks	11
For Sub-Frame 5	Code Blocks	N/A
Binary Channel Bits Per Sub-Frame		
For Sub-Frames 1,2,3,4,6,7,8,9	Bits	75600
For Sub-Frame 5	Bits	N/A
For Sub-Frame 0	Bits	73080
Max. Throughput averaged over 1 frame	Mbps	57.398
UE Category		≥ 5
Note 1:	3 symbols allocated to PDCCH.	
Note 2:	Reference signal, synchronization signals and PBCH allocated as per TS 36.211 [4].	
Note 3:	If more than one Code Block is present, an additional CRC sequence of L = 24 Bits is attached to each Code Block (otherwise L = 0 Bit).	

A.3.3.2 Multi-antenna transmission (Common Reference Symbols)

A.3.3.2.1 Two antenna ports

Table A.3.3.2.1-1: Fixed Reference Channel two antenna ports

Parameter	Unit	Value							
		R.10 FDD	R.11 FDD	R.11-2 FDD	R.11-3 FDD Note 5	R.11-4 FDD	R.30 FDD	R.35-1 FDD	R.35 FDD
Reference channel									
Channel bandwidth	MHz	10	10	5	10	10	20	20	10
Allocated resource blocks (Note 4)		50	50	25	40	50	100	100	50
Allocated subframes per Radio Frame		9	9	9	9	9	9	8	9
Modulation		QPSK	16QAM	16QAM	16QAM	QPSK	16QAM	64QAM	64QAM
Target Coding Rate		1/3	1/2	1/2	1/2	1/2	1/2	0.39	1/2
Information Bit Payload (Note 4)									
For Sub-Frames 1,2,3,4,6,7,8,9	Bits	4392	12960	5736	10296	6968	25456	30576	19848
For Sub-Frame 5	Bits	n/a	n/a	n/a	n/a	n/a	n/a	n/a	n/a
For Sub-Frame 0	Bits	4392	12960	4968	10296	6968	25456	n/a	18336
Number of Code Blocks (Notes 3 and 4)									
For Sub-Frames 1,2,3,4,6,7,8,9	Bits	1	3	1	2	2	5	5	4
For Sub-Frame 5	Bits	n/a	n/a	n/a	n/a	n/a	n/a	n/a	n/a
For Sub-Frame 0	Bits	1	3	1	2	2	5	n/a	3
Binary Channel Bits (Note 4)									
For Sub-Frames 1,2,3,4,6,7,8,9	Bits	13200	26400	12000	21120	13200	52800	79200	39600
For Sub-Frame 5	Bits	n/a	n/a	n/a	n/a	n/a	n/a	n/a	n/a
For Sub-Frame 0	Bits	12384	24768	10368	19488	12384	51168	n/a	37152
Max. Throughput averaged over 1 frame (Note 4)	Mbps	3.953	11.664	5.086	9.266	6.271	22.910	24.461	17.712
UE Category		≥ 1	≥ 2	≥ 1	≥ 1	≥ 1	≥ 2	4	≥ 2
Note 1:	2 symbols allocated to PDCCH for 20 MHz, 15 MHz and 10 MHz channel BW; 3 symbols allocated to PDCCH for 5 MHz and 3 MHz; 4 symbols allocated to PDCCH for 1.4 MHz.								
Note 2:	Reference signal, synchronization signals and PBCH allocated as per TS 36.211 [4].								
Note 3:	If more than one Code Block is present, an additional CRC sequence of L = 24 Bits is attached to each Code Block (otherwise L = 0 Bit).								
Note 4:	Given per component carrier per codeword.								
Note 5:	For R.11-3 resource blocks of RB6–RB45 are allocated.								

A.3.3.2.2 Four antenna ports

Table A.3.3.2.2-1: Fixed Reference Channel four antenna ports

Parameter	Unit	Value						
		R.12 FDD	R.13 FDD	R.14 FDD	R.14- 1 FDD	R.14- 2 FDD	R.14- 3 FDD	R.36 FDD
Reference channel								
Channel bandwidth	MHz	1.4	10	10	10	10	20	10
Allocated resource blocks (Note 4)		6	50	50	6	3	100	50
Allocated subframes per Radio Frame		9	9	9	8	8	9	9
Modulation		QPSK	QPSK	16QA M	16QA M	16QA M	16QA M	64QA M
Target Coding Rate		1/3	1/3	1/2	1/2	1/2	1/2	1/2
Information Bit Payload (Note 4)								
For Sub-Frames 1,2,3,4,6,7,8,9	Bits	408	4392	12960	1544	744	25456	18336
For Sub-Frame 5	Bits	n/a	n/a	n/a	n/a	n/a	n/a	n/a
For Sub-Frame 0	Bits	152	3624	11448	n/a	n/a	22920	18336
Number of Code Blocks (Notes 3 and 4)								
For Sub-Frames 1,2,3,4,6,7,8,9		1	1	3	1	1	5	3
For Sub-Frame 5		n/a	n/a	n/a	n/a	n/a	n/a	n/a
For Sub-Frame 0		1	1	2	n/a	n/a	4	3
Binary Channel Bits (Note 4)								
For Sub-Frames 1,2,3,4,6,7,8,9	Bits	1248	12800	25600	3072	1536	51200	38400
For Sub-Frame 5	Bits	n/a	n/a	n/a	n/a	n/a	n/a	n/a
For Sub-Frame 0	Bits	480	12032	24064	n/a	n/a	49664	36096
Max. Throughput averaged over 1 frame (Note 4)	Mbps	0.342	3.876	11.51 3	1.235	0.595	22.65 68	16.50 2
UE Category		≥ 1	≥ 1	≥ 2	≥ 1	≥ 1	≥ 2	≥ 2
Note 1:	2 symbols allocated to PDCCH for 20 MHz, 15 MHz and 10 MHz channel BW; 3 symbols allocated to PDCCH for 5 MHz and 3 MHz; 4 symbols allocated to PDCCH for 1.4 MHz.							
Note 2:	Reference signal, synchronization signals and PBCH allocated as per TS 36.211 [4].							
Note 3:	If more than one Code Block is present, an additional CRC sequence of L = 24 Bits is attached to each Code Block (otherwise L = 0 Bit).							
Note 4:	Given per component carrier per codeword.							

A.3.3.3 Reference Measurement Channel for UE-Specific Reference Symbols

A.3.3.3.1 Two antenna port (CSI-RS)

The reference measurement channels in Table A.3.3.3.1-1 apply for verifying demodulation performance for UE-specific reference symbols with two cell-specific antenna ports and two CSI-RS antenna ports.

Table A.3.3.3.1-1: Fixed Reference Channel for CDM-multiplexed DM RS with two CSI-RS antenna ports

Parameter	Unit	Value
Reference channel		R.51 FDD
Channel bandwidth	MHz	10
Allocated resource blocks		50 (Note 3)
Allocated subframes per Radio Frame		9
Modulation		16QAM
Target Coding Rate		1/2
Information Bit Payload		
For Sub-Frames 1,4,6,9	Bits	11448
For Sub-Frames 2,3,7,8	Bits	11448
For Sub-Frame 5	Bits	n/a
For Sub-Frame 0	Bits	9528
Number of Code Blocks (Note 4)		
For Sub-Frames 1,4,6,9	Code blocks	2
For Sub-Frames 2,3,7,8	Code blocks	2
For Sub-Frame 5	Bits	n/a
For Sub-Frame 0	Bits	2
Binary Channel Bits		
For Sub-Frames 1,4,6,9	Bits	24000
For Sub-Frames 2,7		23600
For Sub-Frames 3,8		23200
For Sub-Frame 5	Bits	n/a
For Sub-Frame 0	Bits	19680
Max. Throughput averaged over 1 frame	Mbps	10.1112
UE Category		≥ 2
Note 1:	2 symbols allocated to PDCCH.	
Note 2:	Reference signal, synchronization signals and PBCH allocated as per TS 36.211 [4].	
Note 3:	50 resource blocks are allocated in sub-frames 1, 2, 3, 4, 6, 7, 8, 9 and 41 resource blocks (RB0–RB20 and RB30–RB49) are allocated in sub-frame 0.	
Note 4:	If more than one Code Block is present, an additional CRC sequence of L = 24 Bits is attached to each Code Block (otherwise L = 0 Bit).	

A.3.3.3.2 Four antenna ports (CSI-RS)

The reference measurement channels in Table A.3.3.3.2-1 apply for verifying demodulation performance for UE-specific reference symbols with two cell-specific antenna ports and four CSI-RS antenna ports.

Table A.3.3.3.2-1: Fixed Reference Channel for CDM-multiplexed DM RS with four CSI-RS antenna ports

Parameter	Unit	Value	
Reference channel		R.43 FDD	R.50 FDD
Channel bandwidth	MHz	10	10
Allocated resource blocks		50 (Note 3)	50 (Note 3)
Allocated subframes per Radio Frame		9	9
Modulation		QPSK	64QAM
Target Coding Rate		1/3	1/2
Information Bit Payload			
For Sub-Frames 1,4,6,9	Bits	3624	18336
For Sub-Frames 2,3,7,8	Bits	3624	16416
For Sub-Frame 5	Bits	n/a	n/a
For Sub-Frame 0	Bits	2984	14688
Number of Code Blocks (Note 4)			
For Sub-Frames 1,4,6,9	Code blocks	1	3
For Sub-Frames 2,3,7,8	Code blocks	1	3
For Sub-Frame 5	Bits	n/a	n/a
For Sub-Frame 0	Bits	1	3
Binary Channel Bits			
For Sub-Frames 1,4,6,9	Bits	12000	36000
For Sub-Frames 2,7		11600	34800
For Sub-Frames 3,8		11600	34800
For Sub-Frame 5	Bits	n/a	n/a
For Sub-Frame 0	Bits	9840	29520
Max. Throughput averaged over 1 frame	Mbps	3.1976	15.3696
UE Category		≥ 1	≥ 2
Note 1: 2 symbols allocated to PDCCH. Note 2: Reference signal, synchronization signals and PBCH allocated as per TS 36.211 [4]. Note 3: 50 resource blocks are allocated in sub-frames 1, 2, 3, 4, 6, 7, 8, 9 and 41 resource blocks (RB0–RB20 and RB30–RB49) are allocated in sub-frame 0. Note 4: If more than one Code Block is present, an additional CRC sequence of L = 24 Bits is attached to each Code Block (otherwise L = 0 Bit).			

The reference measurement channels in Table A.3.3.3.2-2 apply for verifying FDD PMI accuracy measurement with two CRS antenna ports and four CSI-RS antenna ports.

Table A.3.3.3.2-2: Fixed Reference Channel for four antenna ports (CSI-RS)

Parameter	Unit	Value		
		R.44 FDD	R.45 FDD	R.45-1 FDD
Reference channel				
Channel bandwidth	MHz	10	10	10
Allocated resource blocks		50 ³	50 ³	39
Allocated subframes per Radio Frame		10	10	10
Modulation		QPSK	16QAM	16QAM
Target Coding Rate		1/3	1/2	1/2
Information Bit Payload				
For Sub-Frames (Non CSI-RS subframe)	Bits	3624	11448	8760
For Sub-Frames (CSI-RS subframe)	Bits	3624	11448	8760
For Sub-Frames (ZeroPowerCSI-RS subframe)	Bits	n/a	n/a	n/a
For Sub-Frame 5	Bits	n/a	n/a	n/a
For Sub-Frame 0	Bits	2984	9528	8760
Number of Code Blocks per Sub-Frame (Note 4)				
For Sub-Frames (Non CSI-RS subframe)		1	2	2
For Sub-Frames (CSI-RS subframe)		1	2	2
For Sub-Frames (ZeroPowerCSI-RS subframe)	Bits	n/a	n/a	n/a
For Sub-Frame 5		n/a	n/a	n/a
For Sub-Frame 0		1	2	2
Binary Channel Bits Per Sub-Frame				
For Sub-Frames (Non CSI-RS subframe)	Bits	12000	24000	18720
For Sub-Frames (CSI-RS subframe)	Bits	11600	23200	18096
For Sub-Frames (ZeroPowerCSI-RS subframe)	Bits	n/a	n/a	n/a
For Sub-Frame 5	Bits	n/a	n/a	n/a
For Sub-Frame 0	Bits	9840	19680	18720
Max. Throughput averaged over 1 frame	Mbps	3.1976	10.1112	7.884
UE Category		≥ 1	≥ 2	≥ 1
<p>Note 1: 2 symbols allocated to PDCCH for 20 MHz, 15 MHz and 10 MHz channel BW; 3 symbols allocated to PDCCH for 5 MHz and 3 MHz; 4 symbols allocated to PDCCH for 1.4 MHz</p> <p>Note 2: Reference signal, synchronization signals and PBCH allocated as per TS 36.211 [4]</p> <p>Note 3: For R.44 and R.45, 50 resource blocks are allocated in sub-frames 1,2,3,4,6,7,8,9 and 41 resource blocks (RB0–RB20 and RB30–RB49) are allocated in sub-frame 0. For R.45-1, 39 resource blocks are allocated in all subframes (RB0–RB20 and RB30–RB47).</p> <p>Note 4: If more than one Code Block is present, an additional CRC sequence of L = 24 Bits is attached to each Code Block (otherwise L = 0 Bit)</p>				

A.3.4 Reference measurement channels for PDSCH performance requirements (TDD)

A.3.4.1 Single-antenna transmission (Common Reference Symbols)

Table A.3.4.1-1: Fixed Reference Channel QPSK R=1/3

Parameter	Unit	Value			
		R.4 TDD	R.42 TDD		R.2 TDD
Reference channel		R.4 TDD	R.42 TDD		R.2 TDD
Channel bandwidth	MHz	1.4	20		10
Allocated resource blocks (Note 6)		6	100		50
Uplink-Downlink Configuration (Note 4)		1	1		1
Allocated subframes per Radio Frame (D+S)		3	3+2		3+2
Modulation		QPSK	QPSK		QPSK
Target Coding Rate		1/3	1/3		1/3
Information Bit Payload (Note 6)					
For Sub-Frames 4,9	Bits	408	8760		4392
For Sub-Frames 1,6	Bits	n/a	7736		3240
For Sub-Frame 5	Bits	n/a	n/a		n/a
For Sub-Frame 0	Bits	208	8760		4392
Number of Code Blocks (Notes 5 and 6)					
For Sub-Frames 4,9		1	2		1
For Sub-Frames 1,6		n/a	2		1
For Sub-Frame 5		n/a	n/a		n/a
For Sub-Frame 0		1	2		1
Binary Channel Bits (Note 6)					
For Sub-Frames 4,9	Bits	1368	27600		13800
For Sub-Frames 1,6	Bits	n/a	22656		11256
For Sub-Frame 5	Bits	n/a	n/a		n/a
For Sub-Frame 0	Bits	672	26904		13104
Max. Throughput averaged over 1 frame (Note 6)	Mbps	0.102	4.175		1.966
UE Category		≥ 1	≥ 1		≥ 1
Note 1:	2 symbols allocated to PDCCH for 20 MHz, 15 MHz and 10 MHz channel BW; 3 symbols allocated to PDCCH for 5 MHz and 3 MHz; 4 symbols allocated to PDCCH for 1.4 MHz. For subframe 1&6, only 2 OFDM symbols are allocated to PDCCH.				
Note 2:	For BW=1.4 MHz, the information bit payloads of special subframes are set to zero (no scheduling) to avoid problems with insufficient PDCCH performance at the test point.				
Note 3:	Reference signal, synchronization signals and PBCH allocated as per TS 36.211 [4]				
Note 4:	As per Table 4.2-2 in TS 36.211 [4].				
Note 5:	If more than one Code Block is present, an additional CRC sequence of L = 24 Bits is attached to each Code Block (otherwise L = 0 Bit).				
Note 6:	Given per component carrier per codeword.				

Table A.3.4.1-2: Fixed Reference Channel 16QAM R=1/2

Parameter	Unit	Value					
				R.3-1 TDD	R.3 TDD		
Reference channel							
Channel bandwidth	MHz	1.4	3	5	10	15	20
Allocated resource blocks				25	50		
Uplink-Downlink Configuration (Note 3)				1	1		
Allocated subframes per Radio Frame (D+S)				3+2	3+2		
Modulation				16QAM	16QAM		
Target Coding Rate				1/2	1/2		
Information Bit Payload							
For Sub-Frames 4,9	Bits			6456	14112		
For Sub-Frames 1,6	Bits			5160	11448		
For Sub-Frame 5	Bits			n/a	n/a		
For Sub-Frame 0	Bits			5736	12960		
Number of Code Blocks per Sub-Frame (Note 4)							
For Sub-Frames 4,9				2	3		
For Sub-Frames 1,6				1	2		
For Sub-Frame 5				n/a	n/a		
For Sub-Frame 0				1	3		
Binary Channel Bits Per Sub-Frame							
For Sub-Frames 4,9	Bits			12600	27600		
For Sub-Frames 1,6	Bits			11112	22512		
For Sub-Frame 5	Bits			n/a	n/a		
For Sub-Frame 0	Bits			11208	26208		
Max. Throughput averaged over 1 frame	Mbps			2.897	6.408		
UE Category				≥ 1	≥ 2		
Note 1:	2 symbols allocated to PDCCH for 20 MHz, 15 MHz and 10 MHz channel BW; 3 symbols allocated to PDCCH for 5 MHz and 3 MHz; 4 symbols allocated to PDCCH for 1.4 MHz. For subframe 1&6, only 2 OFDM symbols are allocated to PDCCH.						
Note 2:	Reference signal, synchronization signals and PBCH allocated as per TS 36.211 [4]						
Note 3:	As per Table 4.2-2 in TS 36.211 [4].						
Note 4:	If more than one Code Block is present, an additional CRC sequence of L = 24 Bits is attached to each Code Block (otherwise L = 0 Bit).						

Table A.3.4.1-3: Fixed Reference Channel 64QAM R=3/4

Parameter	Unit	Value					
			R.5 TDD	R.6 TDD	R.7 TDD	R.8 TDD	R.9 TDD
Reference channel							
Channel bandwidth	MHz	1.4	3	5	10	15	20
Allocated resource blocks			15	25	50	75	100
Uplink-Downlink Configuration (Note 3)			1	1	1	1	1
Allocated subframes per Radio Frame (D+S)			3+2	3+2	3+2	3+2	3+2
Modulation		64QAM	64QAM	64QAM	64QAM	64QAM	64QAM
Target Coding Rate			3/4	3/4	3/4	3/4	3/4
Information Bit Payload							
For Sub-Frames 4,9	Bits		8504	14112	30576	46888	61664
For Sub-Frames 1,6	Bits		6968	11448	23688	35160	46888
For Sub-Frame 5	Bits		n/a	n/a	n/a	n/a	n/a
For Sub-Frame 0	Bits		6968	12576	30576	45352	61664
Number of Code Blocks per Sub-Frame (Note 4)							
For Sub-Frames 4,9			2	3	5	8	11
For Sub-Frames 1,6			2	2	4	6	8
For Sub-Frame 5			n/a	n/a	n/a	n/a	n/a
For Sub-Frame 0			2	3	5	8	11
Binary Channel Bits Per Sub-Frame							
For Sub-Frames 4,9	Bits		11340	18900	41400	62100	82800
For Sub-Frames 1,6	Bits		9828	16668	33768	50868	67968
For Sub-Frame 5	Bits		n/a	n/a	n/a	n/a	n/a
For Sub-Frame 0	Bits		9252	16812	39312	60012	80712
Max. Throughput averaged over 1 frame	Mbps		3.791	6.370	13.910	20.945	27.877
UE Category			≥ 1	≥ 2	≥ 2	≥ 2	≥ 3
Note 1:	2 symbols allocated to PDCCH for 20 MHz, 15 MHz and 10 MHz channel BW; 3 symbols allocated to PDCCH for 5 MHz and 3 MHz; 4 symbols allocated to PDCCH for 1.4 MHz. For subframe 1&6, only 2 OFDM symbols are allocated to PDCCH.						
Note 2:	Reference signal, synchronization signals and PBCH allocated as per TS 36.211 [4]						
Note 3:	As per Table 4.2-2 TS 36.211 [4].						
Note 4:	If more than one Code Block is present, an additional CRC sequence of L = 24 Bits is attached to each Code Block (otherwise L = 0 Bit).						

Table A.3.4.1-3a: Fixed Reference Channel 64QAM R=3/4

Parameter	Unit	Value				
		R.6-1 TDD	R.7-1 TDD	R.8-1 TDD	R.9-1 TDD	R.9-2 TDD
Reference channel						
Channel bandwidth	MHz	5	10	15	20	20
Allocated resource blocks (Note 3)		18	17	17	17	83
Uplink-Downlink Configuration (Note 4)		1	1	1	1	1
Allocated subframes per Radio Frame (D+S)		3+2	3+2	3+2	3+2	3+2
Modulation		64QAM	64QAM	64QAM	64QAM	64QAM
Target Coding Rate		3/4	3/4	3/4	3/4	3/4
Information Bit Payload						
For Sub-Frames 4,9	Bits	10296	10296	10296	10296	51024
For Sub-Frames 1,6	Bits	8248	7480	7480	7480	39232
For Sub-Frame 5	Bits	n/a	n/a	n/a	n/a	n/a
For Sub-Frame 0	Bits	8248	10296	10296	10296	51024
Number of Code Blocks per Sub-Frame (Note 5)						
For Sub-Frames 4,9		2	2	2	2	9
For Sub-Frames 1,6		2	2	2	2	7
For Sub-Frame 5		n/a	n/a	n/a	n/a	n/a
For Sub-Frame 0		2	2	2	2	9
Binary Channel Bits Per Sub-Frame						
For Sub-Frames 4,9	Bits	13608	14076	14076	14076	68724
For Sub-Frames 1,6	Bits	11880	11628	11628	11628	56340
For Sub-Frame 5	Bits	n/a	n/a	n/a	n/a	n/a
For Sub-Frame 0	Bits	11520	14076	14076	14076	66636
Max. Throughput averaged over 1 frame	Mbps	4.534	4.585	4.585	4.585	23.154
UE Category		≥ 1	≥ 1	≥ 1	≥ 1	≥ 2
Note 1:	2 symbols allocated to PDCCH for 20 MHz, 15 MHz and 10 MHz channel BW; 3 symbols allocated to PDCCH for 5 MHz and 3 MHz; 4 symbols allocated to PDCCH for 1.4 MHz. For subframe 1&6, only 2 OFDM symbols are allocated to PDCCH.					
Note 2:	Reference signal, synchronization signals and PBCH allocated as per TS 36.211 [4]					
Note 3:	Localized allocation started from RB #0 is applied.					
Note 4:	As per Table 4.2-2 TS 36.211 [4].					
Note 5:	If more than one Code Block is present, an additional CRC sequence of L = 24 Bits is attached to each Code Block (otherwise L = 0 Bit).					

Table A.3.4.1-4: Fixed Reference Channel Single PRB

Parameter	Unit	Value					
			R.0 TDD		R.1 TDD		
Reference channel							
Channel bandwidth	MHz	1.4	3	5	10/20	15	20
Allocated resource blocks			1		1		
Uplink-Downlink Configuration (Note 3)			1		1		
Allocated subframes per Radio Frame (D+S)			3+2		3+2		
Modulation			16QAM		16QAM		
Target Coding Rate			1/2		1/2		
Information Bit Payload							
For Sub-Frames 4,9	Bits		224		256		
For Sub-Frames 1,6	Bits		208		208		
For Sub-Frame 5	Bits		n/a		n/a		
For Sub-Frame 0	Bits		224		256		
Number of Code Blocks per Sub-Frame (Note 4)							
For Sub-Frames 4,9			1		1		
For Sub-Frames 1,6			1		1		
For Sub-Frame 5			n/a		n/a		
For Sub-Frame 0			1		1		
Binary Channel Bits Per Sub-Frame							
For Sub-Frames 4,9	Bits		504		552		
For Sub-Frames 1,6	Bits		456		456		
For Sub-Frame 5	Bits		n/a		n/a		
For Sub-Frame 0	Bits		504		552		
Max. Throughput averaged over 1 frame	Mbps		0.109		0.118		
UE Category			≥ 1		≥ 1		
Note 1:	2 symbols allocated to PDCCH for 20 MHz, 15 MHz and 10 MHz channel BW; 3 symbols allocated to PDCCH for 5 MHz and 3 MHz; 4 symbols allocated to PDCCH for 1.4 MHz. For subframe 1&6, only 2 OFDM symbols are allocated to PDCCH.						
Note 2:	Reference signal, synchronization signals and PBCH allocated as per TS 36.211 [4]						
Note 3:	As per Table 4.2-2 in TS 36.211 [4].						
Note 4:	If more than one Code Block is present, an additional CRC sequence of L = 24 Bits is attached to each Code Block (otherwise L = 0 Bit).						

Table A.3.4.1-5: Fixed Reference Channel Single PRB (MBSFN Configuration)

Parameter	Unit	Value
Reference channel		R.29 TDD (MBSFN)
Channel bandwidth	MHz	10
Allocated resource blocks		1
MBSFN Configuration (Note 3)		010010
Uplink-Downlink Configuration (Note4)		1
Allocated subframes per Radio Frame (D+S)		1+2
Modulation		16QAM
Target Coding Rate		1/2
Information Bit Payload		
For Sub-Frames 4,9	Bits	0 (MBSFN)
For Sub-Frames 1,6	Bits	208
For Sub-Frame 5	Bits	n/a
For Sub-Frame 0	Bits	256
Number of Code Blocks per Sub-Frame (Note 5)		
For Sub-Frames 4,9	Bits	0 (MBSFN)
For Sub-Frames 1,6	Bits	1
For Sub-Frame 5	Bits	n/a
For Sub-Frame 0	Bits	1
Binary Channel Bits Per Sub-Frame		
For Sub-Frames 4,9	Bits	0 (MBSFN)
For Sub-Frames 1,6	Bits	456
For Sub-Frame 5	Bits	n/a
For Sub-Frame 0	Bits	552
Max. Throughput averaged over 1 frame	kbps	67.2
UE Category		≥ 1
Note 1:	2 symbols allocated to PDCCH.	
Note 2:	Reference signal, synchronization signals and PBCH allocated as per TS 36.211 [4].	
Note 3:	MBSFN Subframe Allocation as defined in [7], one frame with 6 bits is chosen for MBSFN subframe allocation.	
Note 4:	as per Table 4.2-2 in TS 36.211 [4].	
Note 5:	If more than one Code Block is present, an additional CRC sequence of L = 24 Bits is attached to each Code Block (otherwise L = 0 Bit).	

Table A.3.4.1-6: Fixed Reference Channel QPSK R=1/10

Parameter	Unit	Value					
					R.41 TDD		
Reference channel							
Channel bandwidth	MHz	1.4	3	5	10	15	20
Allocated resource blocks					50		
Uplink-Downlink Configuration (Note 4)					1		
Allocated subframes per Radio Frame (D+S)					3+2		
Modulation					QPSK		
Target Coding Rate					1/10		
Information Bit Payload							
For Sub-Frames 4,9	Bits				1384		
For Sub-Frames 1,6	Bits				1032		
For Sub-Frame 5	Bits				n/a		
For Sub-Frame 0	Bits				1384		
Number of Code Blocks per Sub-Frame (Note 5)							
For Sub-Frames 4,9					1		
For Sub-Frames 1,6					1		
For Sub-Frame 5					n/a		
For Sub-Frame 0					1		
Binary Channel Bits Per Sub-Frame							
For Sub-Frames 4,9	Bits				13800		
For Sub-Frames 1,6	Bits				11256		
For Sub-Frame 5	Bits				n/a		
For Sub-Frame 0	Bits				13104		
Max. Throughput averaged over 1 frame	Mbps				0.622		
UE Category					≥ 1		
Note 1:	2 symbols allocated to PDCCH for 20 MHz, 15 MHz and 10 MHz channel BW; 3 symbols allocated to PDCCH for 5 MHz and 3 MHz; 4 symbols allocated to PDCCH for 1.4 MHz. For subframe 1&6, only 2 OFDM symbols are allocated to PDCCH.						
Note 2:	For BW=1.4 MHz, the information bit payloads of special subframes are set to zero (no scheduling) to avoid problems with insufficient PDCCH performance at the test point.						
Note 3:	Reference signal, synchronization signals and PBCH allocated as per TS 36.211 [4]						
Note 4:	As per Table 4.2-2 in TS 36.211 [4].						
Note 5:	If more than one Code Block is present, an additional CRC sequence of L = 24 Bits is attached to each Code Block (otherwise L = 0 Bit).						

Table A.3.4.1-7: PCell Fixed Reference Channel for CA demodulation with power imbalance

Parameter	Unit	Value
Reference channel		R.49 TDD
Channel bandwidth	MHz	20
Allocated resource blocks		100
Uplink-Downlink Configuration (Note 1)		1
Allocated subframes per Radio Frame (D+S)		3+2
Modulation		64QAM
Number of OFDM symbols for PDCCH per component carrier		
For Sub-Frames 0,4,5,9	OFDM symbols	3
For Sub-Frames 1,6	OFDM symbols	2
Target Coding Rate		
For Sub-Frames 4,9		0.84
For Sub-Frames 1,6		0.81
For Sub-Frames 5		N/A
For Sub-Frames 0		0.87
Information Bit Payload		
For Sub-Frames 0, 4, 9	Bits	63776
For Sub-Frame 1,6	Bits	55056
For Sub-Frame 5	Bits	N/A
Number of Code Blocks per Sub-Frame (Note 2)		
For Sub-Frames 0, 4, 9	Code Blocks	11
For Sub-Frame 1,6	Code Blocks	9
For Sub-Frame 5	Code Blocks	N/A
Binary Channel Bits Per Sub-Frame		
For Sub-Frames 4,9	Bits	75600
For Sub-Frame 1,6	Bits	67968
For Sub-Frame 5	Bits	N/A
For Sub-Frame 0	Bits	73512
Max. Throughput averaged over 1 frame	Mbps	30.144
UE Category		≥ 5
Note 1:	Reference signal, synchronization signals and PBC allocated as per TS 36.211 [4].	
Note 2:	If more than one Code Block is present, an additional CRC sequence of L = 24 Bits is attached to each Code Block (otherwise L = 0 Bit).	

A.3.4.2 Multi-antenna transmission (Common Reference Signals)

A.3.4.2.1 Two antenna ports

Table A.3.4.2.1-1: Fixed Reference Channel two antenna ports

Parameter	Unit	Value								
		R.10 TDD	R.11 TDD	R.11-1 TDD	R.11-2 TDD	R.11-3 TDD Note 6	R.11-4 TDD	R.30 TDD	R.30-1 TDD	R.30-2 TDD
Reference channel										
Channel bandwidth	MHz	10	10	10	5	10	10	20	20	20
Allocated resource blocks (Note 5)		50	50	50	25	40	50	100	100	100
Uplink-Downlink Configuration (Note 3)		1	1	1	1	1	1	1	1	1
Allocated subframes per Radio Frame (D+S)		3+2	3+2	2+2	3+2	3+2	2	3+2	2+2	2
Modulation		QPSK	16QAM	16QAM	16QAM	16QAM	QPSK	16QAM	16QAM	16QAM
Target Coding Rate		1/3	1/2	1/2	1/2	1/2	1/2	1/2	1/2	1/2
Information Bit Payload (Note 5)										
For Sub-Frames 4,9	Bits	4392	12960	12960	5736	10296	6968	25456	25456	25456
For Sub-Frames 1,6		3240	9528	9528	5160	9144	n/a	22920	21384	n/a
For Sub-Frame 5	Bits	n/a	n/a	n/a	n/a	n/a	n/a	n/a	n/a	n/a
For Sub-Frame 0	Bits	4392	12960	n/a	4968	10296	n/a	25456	n/a	n/a
Number of Code Blocks (Notes 4 and 5)										
For Sub-Frames 4,9		1	3	3	1	2	2	5	5	5
For Sub-Frames 1,6		1	2	2	1	2	n/a	4	4	n/a
For Sub-Frame 5		n/a	n/a	n/a	n/a	n/a	n/a	n/a	n/a	n/a
For Sub-Frame 0		1	3	n/a	1	2	n/a	5	n/a	n/a
Binary Channel Bits (Note 5)										
For Sub-Frames 4,9	Bits	13200	26400	26400	12000	21120	13200	52800	52800	52800
For Sub-Frames 1,6		10656	21312	21312	10512	16992	10656	42912	42912	n/a
For Sub-Frame 5	Bits	n/a	n/a	n/a	n/a	n/a	n/a	n/a	n/a	n/a
For Sub-Frame 0	Bits	12528	25056	n/a	10656	19776	12528	51456	n/a	n/a
Max. Throughput averaged over 1 frame (Note 5)	Mbps	1.966	5.794	4.498	2.676	4.918	1.39	12.221	9.368	5.091
UE Category		≥ 1	≥ 2	≥ 2	≥ 1	≥ 1	≥ 1	≥ 2	≥ 2	3
Note 1:	2 symbols allocated to PDCCH for 20 MHz, 15 MHz and 10 MHz channel BW; 3 symbols allocated to PDCCH for 5 MHz; 4 symbols allocated to PDCCH for 1.4 MHz. For subframe 1&6, only 2 OFDM symbols are allocated to PDCCH.									
Note 2:	Reference signal, synchronization signals and PBCH allocated as per TS 36.211 [4].									
Note 3:	As per Table 4.2-2 in TS 36.211 [4].									
Note 4:	If more than one Code Block is present, an additional CRC sequence of L = 24 Bits is attached to each Code Block (other than the first Code Block).									
Note 5:	Given per component carrier per codeword.									
Note 6:	For R.11-3 resource blocks of RB6–RB45 are allocated.									

A.3.4.2.2 Four antenna ports

Table A.3.4.2.2-1: Fixed Reference Channel four antenna ports

Parameter	Unit	Value						
		R.12 TDD	R.13 TDD	R.14 TDD	R.14-1 TDD	R.14-2 TDD	R.43 TDD	R.36 TDD
Reference channel								
Channel bandwidth	MHz	1.4	10	10	10	10	20	10
Allocated resource blocks (Note 6)		6	50	50	6	3	100	50
Uplink-Downlink Configuration (Note 4)		1	1	1	1	1	1	1
Allocated subframes per Radio Frame (D+S)		3	3+2	2+2	2	2	2+2	2+2
Modulation		QPSK	QPSK	16QAM	16QAM	16QAM	16QAM	64QAM
Target Coding Rate		1/3	1/3	1/2	1/2	1/2	1/2	1/2
Information Bit Payload (Note 6)								
For Sub-Frames 4,9	Bits	408	4392	12960	1544	744	25456	18336
For Sub-Frames 1,6	Bits	n/a	3240	9528	n/a	n/a	21384	15840
For Sub-Frame 5	Bits	n/a	n/a	n/a	n/a	n/a	n/a	n/a
For Sub-Frame 0	Bits	208	4392	n/a	n/a	n/a	n/a	n/a
Number of Code Blocks (Notes 5 and 6)								
For Sub-Frames 4,9		1	1	3	1	1	5	3
For Sub-Frames 1,6		n/a	1	2	n/a	n/a	4	3
For Sub-Frame 5		n/a	n/a	n/a	n/a	n/a	n/a	n/a
For Sub-Frame 0		1	1	n/a	n/a	n/a	n/a	n/a
Binary Channel Bits (Note 6)								
For Sub-Frames 4,9	Bits	1248	12800	25600	3072	1536	51200	38400
For Sub-Frames 1,6		n/a	10256	20512	n/a	n/a	41312	30768
For Sub-Frame 5	Bits	n/a	n/a	n/a	n/a	n/a	n/a	n/a
For Sub-Frame 0	Bits	624	12176	n/a	n/a	n/a	n/a	n/a
Max. Throughput averaged over 1 frame (Note 6)	Mbps	0.102	1.966	4.498	0.309	0.149	9.368	6.835
UE Category		≥ 1	≥ 1	≥ 2	≥ 1	≥ 1	≥ 2	≥ 2
Note 1:	2 symbols allocated to PDCCH for 20 MHz, 15 MHz and 10 MHz channel BW; 3 symbols allocated to PDCCH for 5 MHz and 3 MHz; 4 symbols allocated to PDCCH for 1.4 MHz. For subframe 1&6, only 2 OFDM symbols are allocated to PDCCH.							
Note 2:	For BW=1.4 MHz, the information bit payloads of special subframes are set to zero (no scheduling) to avoid problems with insufficient PDCCH performance at the test point.							
Note 3:	Reference signal, synchronization signals and PBCH allocated as per TS 36.211 [4].							
Note 4:	As per Table 4.2-2 in TS 36.211 [4].							
Note 5:	If more than one Code Block is present, an additional CRC sequence of L = 24 Bits is attached to each Code Block (otherwise L = 0 Bit).							
Note 6:	Given per component carrier per codeword.							

A.3.4.3 Reference Measurement Channels for UE-Specific Reference Symbols

A.3.4.3.1 Single antenna port (Cell Specific)

The reference measurement channels in Table A.3.4.3.1-1 apply for verifying demodulation performance for UE-specific reference symbols with one cell-specific antenna port.

Table A.3.4.3.1-1: Fixed Reference Channel for DRS

Parameter	Unit	Value					
		R.25 TDD	R.26 TDD	R.26-1 TDD	R.27 TDD	R.27-1 TDD	R.28 TDD
Reference channel							
Channel bandwidth	MHz	10	10	5	10	10	10
Allocated resource blocks		50 ⁴	50 ⁴	25 ⁴	50 ⁴	18 ⁶	1
Uplink-Downlink Configuration (Note 3)		1	1	1	1	1	1
Allocated subframes per Radio Frame (D+S)		3+2	3+2	3+2	3+2	3+2	3+2
Modulation		QPSK	16QAM	16QAM	64QAM	64QAM	16QAM
Target Coding Rate		1/3	1/2	1/2	3/4	3/4	1/2
Information Bit Payload							
For Sub-Frames 4,9	Bits	4392	12960	5736	28336	10296	224
For Sub-Frames 1,6	Bits	3240	9528	4584	22920	8248	176
For Sub-Frame 5	Bits	n/a	n/a	n/a	n/a	n/a	n/a
For Sub-Frame 0	Bits	2984	9528	3880	22152	10296	224
Number of Code Blocks per Sub-Frame (Note 5)							
For Sub-Frames 4,9		1	3	1	5	2	1
For Sub-Frames 1,6		1	2	1	4	2	1
For Sub-Frame 5		n/a	n/a	n/a	n/a	n/a	n/a
For Sub-Frame 0		1	2	1	4	2	1
Binary Channel Bits Per Sub-Frame							
For Sub-Frames 4,9	Bits	12600	25200	11400	37800	13608	504
For Sub-Frames 1,6	Bits	10356	20712	10212	31068	11340	420
For Sub-Frame 5	Bits	n/a	n/a	n/a	n/a	n/a	n/a
For Sub-Frame 0	Bits	10332	20664	7752	30996	13608	504
Max. Throughput averaged over 1 frame	Mbps	1.825	5.450	2.452	12.466	4.738	0.102
UE Category		≥ 1	≥ 2	≥ 1	≥ 2	≥ 1	≥ 1
Note 1:	2 symbols allocated to PDCCH for 20 MHz, 15 MHz and 10 MHz channel BW; 3 symbols allocated to PDCCH for 5 MHz and 3 MHz; 4 symbols allocated to PDCCH for 1.4 MHz. For subframe 1&6, only 2 OFDM symbols are allocated to PDCCH.						
Note 2:	Reference signal, synchronization signals and PBCH allocated as per TS 36.211 [4].						
Note 3:	as per Table 4.2-2 in TS 36.211 [4].						
Note 4:	For R.25, R.26 and R.27, 50 resource blocks are allocated in sub-frames 1, 4, 6, 9 and 41 resource blocks (RB0–RB20 and RB30–RB49) are allocated in sub-frame 0. For R.26-1, 25 resource blocks are allocated in sub-frames 1, 4, 6, 9 and 17 resource blocks (RB0–RB7 and RB16–RB24) are allocated in sub-frame 0.						
Note 5:	If more than one Code Block is present, an additional CRC sequence of L = 24 Bits is attached to each Code Block (otherwise L = 0 Bit).						
Note 6:	Localized allocation started from RB #0 is applied.						

A.3.4.3.2 Two antenna ports (Cell Specific)

The reference measurement channels in Table A.3.4.3.2-1 apply for verifying demodulation performance for CDM-multiplexed UE specific reference symbols with two cell-specific antenna ports.

Table A.3.4.3.2-1: Fixed Reference Channel for CDM-multiplexed DM RS

Reference channel		R.31 TDD	R.32 TDD	R.32-1 TDD	R.33 TDD	R.33-1 TDD	R.34 TDD	
Channel bandwidth	MHz	10	10	5	10	10	10	
Allocated resource blocks		50 ⁴	50 ⁴	25 ⁴	50 ⁴	18 ⁶	50 ⁴	
Uplink-Downlink Configuration (Note 3)		1	1	1	1	1	1	
Allocated subframes per Radio Frame (D+S)		3+2	3+2	3+2	3+2	3+2	3+2	
Modulation		QPSK	16QAM	16QAM	64QAM	64QAM	64QAM	
Target Coding Rate		1/3	1/2	1/2	3/4	3/4	1/2	
Information Bit Payload								
For Sub-Frames 4,9	Bits	3624	11448	5736	27376	9528	18336	
For Sub-Frames 1,6		2664	7736	3112	16992	7480	11832	
For Sub-Frame 5	Bits	n/a	n/a	n/a	n/a	n/a	n/a	
For Sub-Frame 0	Bits	2984	9528	3496	22152	9528	14688	
Number of Code Blocks per Sub-Frame (Note 5)								
For Sub-Frames 4,9		1	2	1	5	2	3	
For Sub-Frames 1,6		1	2	1	3	2	2	
For Sub-Frame 5		n/a	n/a	n/a	n/a	n/a	n/a	
For Sub-Frame 0		1	2	1	4	2	3	
Binary Channel Bits Per Sub-Frame								
For Sub-Frames 4,9	Bits	12000	24000	10800	36000	12960	36000	
For Sub-Frames 1,6		7872	15744	6528	23616	10368	23616	
For Sub-Frame 5	Bits	n/a	n/a	n/a	n/a	n/a	n/a	
For Sub-Frame 0	Bits	9840	19680	7344	29520	12960	29520	
Max. Throughput averaged over 1 frame	Mbps	1.556	4.79	2.119	11.089	4.354	7.502	
UE Category		≥ 1	≥ 2	≥ 1	≥ 2	≥ 1	≥ 2	
<p>Note 1: 2 symbols allocated to PDCCH for 20 MHz, 15 MHz and 10 MHz channel BW; 3 symbols allocated to PDCCH for 5 MHz and 3 MHz; 4 symbols allocated to PDCCH for 1.4 MHz. For subframe 1&6, only 2 OFDM symbols are allocated to PDCCH.</p> <p>Note 2: Reference signal, synchronization signals and PBCH allocated as per TS 36.211 [4].</p> <p>Note 3: as per Table 4.2-2 in TS 36.211 [4].</p> <p>Note 4: For R.31, R.32, R.33 and R.34, 50 resource blocks are allocated in sub-frames 4,9 and 41 resource blocks (RB0–RB20 and RB30–RB49) are allocated in sub-frame 0 and the DwPTS portion of sub-frames 1,6. For R.32-1, 25 resource blocks are allocated in sub-frames 4,9 and 17 resource blocks (RB0–RB7 and RB16–RB24) are allocated in sub-frame 0 and the DwPTS portion of sub-frames 1, 6.</p> <p>Note 5: If more than one Code Block is present, an additional CRC sequence of L = 24 Bits is attached to each Code Block (otherwise L = 0 Bit).</p> <p>Note 6: Localized allocation started from RB #0 is applied.</p>								

A.3.4.3.3 Two antenna ports (CSI-RS)

The reference measurement channels in Table A.3.4.3.3-1 apply for verifying demodulation performance for CDM-multiplexed UE specific reference symbols with two cell-specific antenna ports and two CSI-RS antenna ports.

Table A.3.4.3.3-1: Fixed Reference Channel for CDM-multiplexed DM RS with two CSI-RS antenna ports

Parameter	Unit	Value
Reference channel		R.51 TDD
Channel bandwidth	MHz	10
Allocated resource blocks		50 (Note 5)
Uplink-Downlink Configuration (Note 3)		1
Allocated subframes per Radio Frame (D+S)		3+2
Modulation		16QAM
Target Coding Rate		1/2
Information Bit Payload		
For Sub-Frames 4,9 (non CSI-RS subframe)	Bits	11448
For Sub-Frame 4,9	Bits	11448
For Sub-Frames 1,6	Bits	7736
For Sub-Frame 5	Bits	n/a
For Sub-Frame 0	Bits	9528
Number of Code Blocks (Note 4)		
For Sub-Frames 4, 9 (non CSI-RS subframe)	Code blocks	2
For Sub-Frames 4,9	Code blocks	2
For Sub-Frames 1,6	Code blocks	2
For Sub-Frame 5		n/a
For Sub-Frame 0	Code blocks	2
Binary Channel Bits		
For Sub-Frames 4, 9 (non CSI-RS subframe)	Bits	24000
For Sub-Frames 4,9		22800
For Sub-Frames 1,6		15744
For Sub-Frame 5	Bits	n/a
For Sub-Frame 0	Bits	19680
Max. Throughput averaged over 1 frame	Mbps	4.7896
UE Category		≥ 2
Note 1:	2 symbols allocated to PDCCH.	
Note 2:	Reference signal, synchronization signals and PBCH allocated as per TS 36.211 [4].	
Note 3:	as per Table 4.2-2 in TS 36.211 [4].	
Note 4:	If more than one Code Block is present, an additional CRC sequence of L = 24 Bits is attached to each Code Block (otherwise L = 0 Bit).	
Note 5:	50 resource blocks are allocated in sub-frames 4,9 and 41 resource blocks (RB0–RB20 and RB30–RB49) are allocated in sub-frame 0 and the DwPTS portion of sub-frames 1,6.	

A.3.4.3.4 Four antenna ports (CSI-RS)

The reference measurement channels in Table A.3.4.3.4-1 apply for verifying demodulation performance for CDM-multiplexed UE specific reference symbols with two cell-specific antenna ports and four CSI-RS antenna ports.

Table A.3.4.3.4-1: Fixed Reference Channel for CDM-multiplexed DM RS with four CSI-RS antenna ports

Parameter	Unit	Value
Reference channel		R.44 TDD
Channel bandwidth	MHz	10
Allocated resource blocks		50 (Note 4)
Uplink-Downlink Configuration (Note 3)		1
Allocated subframes per Radio Frame (D+S)		3+2
Modulation		64QAM
Target Coding Rate		$\frac{1}{2}$
Information Bit Payload		
For Sub-Frames 4,9 (non CSI-RS subframe)	Bits	18336
For Sub-Frames 4,9 (CSI-RS subframe)	Bits	16416
For Sub-Frames 1,6		11832
For Sub-Frame 5	Bits	n/a
For Sub-Frame 0	Bits	14688
Number of Code Blocks per Sub-Frame (Note 5)		
For Sub-Frames 4,9 (non CSI-RS subframe)		3
For Sub-Frames 4,9 (CSI-RS subframe)		3
For Sub-Frames 1,6		2
For Sub-Frame 5		n/a
For Sub-Frame 0		3
Binary Channel Bits Per Sub-Frame		
For Sub-Frames 4,9 (non CSI-RS subframe)	Bits	36000
For Sub-Frames 4,9 (CSI-RS subframe)	Bits	33600
For Sub-Frames 1,6		23616
For Sub-Frame 5	Bits	n/a
For Sub-Frame 0	Bits	29520
Max. Throughput averaged over 1 frame	Mbps	7.1184
UE Category		≥ 2
Note 1: 2 symbols allocated to PDCCH. Note 2: Reference signal, synchronization signals and PBCH allocated as per TS 36.211 [4]. Note 3: as per Table 4.2-2 in TS 36.211 [4]. Note 4: 50 resource blocks are allocated in sub-frames 4,9 and 41 resource blocks (RB0–RB20 and RB30–RB49) are allocated in sub-frame 0 and the DwPTS portion of sub-frames 1,6. Note 5: If more than one Code Block is present, an additional CRC sequence of L = 24 Bits is attached to each Code Block (otherwise L = 0 Bit).		

A.3.4.3.5 Eight antenna ports (CSI-RS)

The reference measurement channels in Table A.3.4.3.5-1 apply for verifying demodulation performance for CDM-multiplexed UE specific reference symbols with two cell-specific antenna ports and eight CSI-RS antenna ports.

Table A.3.4.3.5-1: Fixed Reference Channel for CDM-multiplexed DM RS with eight CSI-RS antenna ports

Parameter	Unit	Value
Reference channel		R.50 TDD
Channel bandwidth	MHz	10
Allocated resource blocks		50 (Note 4)
Uplink-Downlink Configuration (Note 3)		1
Allocated subframes per Radio Frame (D+S)		3+2
Modulation		QPSK
Target Coding Rate		1/3
Information Bit Payload		
For Sub-Frames 4,9 (non CSI-RS subframe)	Bits	3624
For Sub-Frames 4,9 (CSI-RS subframe)	Bits	3624
For Sub-Frames 1,6		2664
For Sub-Frame 5	Bits	n/a
For Sub-Frame 0	Bits	2984
Number of Code Blocks per Sub-Frame (Note 5)		
For Sub-Frames 4,9 (non CSI-RS subframe)		1
For Sub-Frames 4,9 (CSI-RS subframe)		1
For Sub-Frames 1,6		1
For Sub-Frame 5		n/a
For Sub-Frame 0		1
Binary Channel Bits Per Sub-Frame		
For Sub-Frames 4,9 (non CSI-RS subframe)	Bits	12000
For Sub-Frames 4,9 (CSI-RS subframe)	Bits	10400
For Sub-Frames 1,6		7872
For Sub-Frame 5	Bits	n/a
For Sub-Frame 0	Bits	9840
Max. Throughput averaged over 1 frame	Mbps	1.556
UE Category		≥ 1
Note 1: 2 symbols allocated to PDCCH. Note 2: Reference signal, synchronization signals and PBCH allocated as per TS 36.211 [4]. Note 3: as per Table 4.2-2 in TS 36.211 [4]. Note 4: 50 resource blocks are allocated in sub-frames 4,9 and 41 resource blocks (RB0–RB20 and RB30–RB49) are allocated in sub-frame 0 and the DwPTS portion of sub-frames 1,6. Note 5: If more than one Code Block is present, an additional CRC sequence of L = 24 Bits is attached to each Code Block (otherwise L = 0 Bit).		

The reference measurement channels in Table A.3.4.3.5-2 apply for verifying TDD PMI accuracy measurement with two CRS antenna ports and eight CSI-RS antenna ports.

Table A.3.4.3.5-2: Fixed Reference Channel for eight antenna ports (CSI-RS)

Parameter	Unit	Value		
		R.45 TDD	R.45-1 TDD	
Reference channel				
Channel bandwidth	MHz	10	10	
Allocated resource blocks		50 ⁴	39	
Uplink-Downlink Configuration (Note 3)		1	1	
Allocated subframes per Radio Frame (D+S)		4+2	4+2	
Allocated subframes per Radio Frame		10	10	
Modulation		16QAM	16QAM	
Target Coding Rate		1/2	1/2	
Information Bit Payload				
For Sub-Frames 4 and 9 (Non CSI-RS subframe)	Bits	n/a	n/a	
For Sub-Frames 4 and 9 (CSI-RS subframe)	Bits	11448	8760	
For Sub-Frames 1,6	Bits	7736	7480	
For Sub-Frame 5	Bits	n/a	n/a	
For Sub-Frame 0	Bits	9528	8760	
Number of Code Blocks per Sub-Frame (Note 5)				
For Sub-Frames 4 and 9 (Non CSI-RS subframe)		n/a	n/a	
For Sub-Frames 4 and 9 (CSI-RS subframe)		2	2	
For Sub-Frames 1,6		2	2	
For Sub-Frame 5		n/a	n/a	
For Sub-Frame 0		2	2	
Binary Channel Bits Per Sub-Frame				
For Sub-Frames 4 and 9 (Non CSI-RS subframe)	Bits	n/a	n/a	
For Sub-Frames 4 and 9 (CSI-RS subframe)	Bits	22400	17472	
For Sub-Frames 1,6	Bits	15744	14976	
For Sub-Frame 5	Bits	n/a	n/a	
For Sub-Frame 0	Bits	19680	18720	
Max. Throughput averaged over 1 frame	Mbps	4.7896	4.1240	
UE Category		≥ 2	≥ 1	
Note 1:	2 symbols allocated to PDCCH for 20 MHz, 15 MHz and 10 MHz channel BW; 3 symbols allocated to PDCCH for 5 MHz and 3 MHz; 4 symbols allocated to PDCCH for 1.4 MHz. For subframe 1&6, only 2 OFDM symbols are allocated to PDCCH.			
Note 2:	Reference signal, synchronization signals and PBCH allocated as per TS 36.211 [4].			
Note 3:	As per Table 4.2-2 in TS 36.211 [4].			
Note 4:	For R.45, 50 resource blocks are allocated in sub-frames 4,9 and 41 resource blocks (RB0–RB20 and RB30–RB49) are allocated in sub-frame 0 and the DwPTS portion of sub-frames 1,6. For R.45-1, 39 resource blocks are allocated in sub-frames 0,4,9 and the DwPTS portion of sub-frames 1,6 (RB0–RB20 and RB30–RB47).			
Note 5:	If more than one Code Block is present, an additional CRC sequence of L = 24 Bits is attached to each Code Block (otherwise L = 0 Bit).			
Note 6:	Localized allocation started from RB #0 is applied.			

A.3.5 Reference measurement channels for PDCCH/PCFICH performance requirements

A.3.5.1 FDD

Table A.3.5.1-1: Reference Channel FDD

Parameter	Unit	Value			
		R.15 FDD	R.15-1 FDD	R.16 FDD	R.17 FDD
Reference channel		R.15 FDD	R.15-1 FDD	R.16 FDD	R.17 FDD
Number of transmitter antennas		1	2	2	4
Channel bandwidth	MHz	10	10	10	5
Number of OFDM symbols for PDCCH	symbols	2	3	2	2
Aggregation level	CCE	8	8	4	2
DCI Format		Format 1	Format 1	Format 2	Format 2
Cell ID		0	0	0	0
Payload (without CRC)	Bits	31	31	43	42

A.3.5.2 TDD

Table A.3.5.2-1: Reference Channel TDD

Parameter	Unit	Value			
		R.15 TDD	R.15-1 TDD	R.16 TDD	R.17 TDD
Reference channel		R.15 TDD	R.15-1 TDD	R.16 TDD	R.17 TDD
Number of transmitter antennas		1	2	2	4
Channel bandwidth	MHz	10	10	10	5
Number of OFDM symbols for PDCCH	symbols	2	3	2	2
Aggregation level	CCE	8	8	4	2
DCI Format		Format 1	Format 1	Format 2	Format 2
Cell ID		0	0	0	0
Payload (without CRC)	Bits	34	34	46	45

A.3.6 Reference measurement channels for PHICH performance requirements

Table A.3.6-1: Reference Channel FDD/TDD

Parameter	Unit	Value			
		R.18	R.19	R.20	R.24
Reference channel		R.18	R.19	R.20	R.24
Number of transmitter antennas		1	2	4	1
Channel bandwidth	MHz	10	10	5	10
User roles (Note 1)		W I1 I2	W I1 I2	W I1 I2	W I1
Resource allocation (Note 2)		(0,0) (0,1) (0,4)	(0,0) (0,1) (0,4)	(0,0) (0,1) (0,4)	(0,0) (0,1)
Power offsets (Note 3)	dB	-4 0 -3	-4 0 -3	-4 0 -3	+3 0
Payload (Note 4)		A R R	A R R	A R R	A R
Note 1: W=wanted user, I1=interfering user 1, I2=interfering user 2. Note 2: The resource allocation per user is given as (N_group_PHICH, N_seq_PHICH). Note 3: The power offsets (per user) represent the difference of the power of BPSK modulated symbol per PHICH relative to the first interfering user. Note 4: A=fixed ACK, R=random ACK/NACK.					

A.3.7 Reference measurement channels for PBCH performance requirements

Table A.3.7-1: Reference Channel FDD/TDD

Parameter	Unit	Value		
		R.21	R.22	R.23
Reference channel		R.21	R.22	R.23
Number of transmitter antennas		1	2	4
Channel bandwidth	MHz	1.4	1.4	1.4
Modulation		QPSK	QPSK	QPSK
Target coding rate		40/1920	40/1920	40/1920
Payload (without CRC)	Bits	24	24	24

A.3.8 Reference measurement channels for MBMS performance requirements

A.3.8.1 FDD

Table A.3.8.1-1: Fixed Reference Channel QPSK R=1/3

Parameter	PMCH						
	Unit	Value					
Reference channel		R.40 FDD			R.37 FDD		
Channel bandwidth	MHz	1.4	3	5	10	15	20
Allocated resource blocks		6			50		
Allocated subframes per Radio Frame (Note 1)		6			6		
Modulation		QPSK			QPSK		
Target Coding Rate		1/3			1/3		
Information Bit Payload (Note 2)							
For Sub-Frames 1,2,3,6,7,8	Bits	408			3624		
For Sub-Frames 0,4,5,9	Bits	n/a			n/a		
Number of Code Blocks per Subframe (Note 3)		1			1		
Binary Channel Bits Per Subframe							
For Sub-Frames 1,2,3,6,7,8	Bits	1224			10200		
For Sub-Frames 0,4,5,9	Bits	n/a			n/a		
MBMS UE Category		≥ 1			≥ 1		
Note 1:	For FDD mode, up to 6 subframes (#1/2/3/6/7/8) are available for MBMS, in line with TS 36.331.						
Note 2:	2 OFDM symbols are reserved for PDCCH; and reference signal allocated as per TS 36.211.						
Note 3:	If more than one Code Block is present, an additional CRC sequence of L = 24 Bits is attached to each Code Block (otherwise L = 0 Bit).						

Table A.3.8.1-2: Fixed Reference Channel 16QAM R=1/2

Parameter	PMCH						
	Unit	Value					
Reference channel					R.38 FDD		
Channel bandwidth	MHz	1.4	3	5	10	15	20
Allocated resource blocks					50		
Allocated subframes per Radio Frame (Note 1)					6		
Modulation					16QAM		
Target Coding Rate					1/2		
Information Bit Payload (Note 2)							
For Sub-Frames 1,2,3,6,7,8	Bits				9912		
For Sub-Frames 0,4,5,9	Bits				n/a		
Number of Code Blocks per Subframe (Note 3)					2		
Binary Channel Bits Per Subframe							
For Sub-Frames 1,2,3,6,7,8	Bits				20400		
For Sub-Frames 0,4,5,9	Bits				n/a		
MBMS UE Category					≥ 1		
Note 1:	For FDD mode, up to 6 subframes (#1/2/3/6/7/8) are available for MBMS, in line with TS 36.331.						
Note 2:	2 OFDM symbols are reserved for PDCCH; and reference signal allocated as per TS 36.211.						
Note 3:	If more than one Code Block is present, an additional CRC sequence of L = 24 Bits is attached to each Code Block (otherwise L = 0 Bit).						

Table A.3.8.1-3: Fixed Reference Channel 64QAM R=2/3

Parameter	PMCH						
	Unit	Value					
Reference channel				39-1 FDD	R.39 FDD		
Channel bandwidth	MHz	1.4	3	5	10	15	20
Allocated resource blocks				25	50		
Allocated subframes per Radio Frame(Note1)				6	6		
Modulation				64QAM	64QAM		
Target Coding Rate				2/3	2/3		
Information Bit Payload (Note 2)							
For Sub-Frames 1,2,3,6,7,8	Bits			9912	19848		
For Sub-Frames 0,4,5,9	Bits			n/a	n/a		
Number of Code Blocks per Sub-Frame (Note 3)				2	4		
Binary Channel Bits Per Subframe							
For Sub-Frames 1,2,3,6,7,8	Bits			15300	30600		
For Sub-Frames 0,4,5,9	Bits			n/a	n/a		
MBMS UE Category				≥ 1	≥ 2		
Note 1:	For FDD mode, up to 6 subframes (#1/2/3/6/7/8) are available for MBMS, in line with TS 36.331.						
Note 2:	2 OFDM symbols are reserved for PDCCH; and reference signal allocated as per TS 36.211.						
Note 3:	If more than one Code Block is present, an additional CRC sequence of L = 24 Bits is attached to each Code Block (otherwise L = 0 Bit).						

A.3.8.2 TDD

Table A.3.8.2-1: Fixed Reference Channel QPSK R=1/3

Parameter	PMCH						
	Unit	Value					
Reference channel		R.40 TDD			R.37 TDD		
Channel bandwidth	MHz	1.4	3	5	10	15	20
Allocated resource blocks		6			50		
Uplink-Downlink Configuration(Note 1)		5			5		
Allocated subframes per Radio Frame		5			5		
Modulation		QPSK			QPSK		
Target Coding Rate		1/3			1/3		
Information Bit Payload (Note 2)							
For Sub-Frames 3,4,7,8,9	Bits	408			3624		
For Sub-Frames 0,1,2,5,6	Bits	n/a			n/a		
Number of Code Blocks per Subframe (Note 3)		1			1		
Binary Channel Bits Per Subframe							
For Sub-Frames 3,4,7,8,9	Bits	1224			10200		
For Sub-Frames 0,1,2,5,6	Bits	n/a			n/a		
MBMS UE Category		≥ 1			≥ 1		
<p>Note 1: For TDD mode, in line with TS 36.331, Uplink-Downlink Configuration 5 is proposed, up to 5 subframes (#3/4/7/8/9) are available for MBMS.</p> <p>Note 2: 2 OFDM symbols are reserved for PDCCH; reference signal allocated as per TS 36.211.</p> <p>Note 3: If more than one Code Block is present, an additional CRC sequence of L = 24 Bits is attached to each Code Block (otherwise L = 0 Bit).</p>							

Table A.3.8.2-2: Fixed Reference Channel 16QAM R=1/2

Parameter	PMCH						
	Unit	Value					
Reference channel					R.38 TDD		
Channel bandwidth	MHz	1.4	3	5	10	15	20
Allocated resource blocks					50		
Uplink-Downlink Configuration(Note 1)					5		
Allocated subframes per Radio Frame					5		
Modulation					16QAM		
Target Coding Rate					1/2		
Information Bit Payload (Note 2)							
For Sub-Frames 3,4,7,8,9	Bits				9912		
For Sub-Frames 0,1,2,5,6	Bits				n/a		
Number of Code Blocks per Subframe (Note 3)					2		
Binary Channel Bits Per Subframe							
For Sub-Frames 3,4,7,8,9	Bits				20400		
For Sub-Frames 0,1,2,5,6	Bits				n/a		
MBMS UE Category					≥ 1		
<p>Note 1: For TDD mode, in line with TS 36.331, Uplink-Downlink Configuration 5 is proposed, up to 5 subframes (#3/4/7/8/9) are available for MBMS.</p> <p>Note 2: 2 OFDM symbols are reserved for PDCCH; reference signal allocated as per TS 36.211.</p> <p>Note 3: If more than one Code Block is present, an additional CRC sequence of L = 24 Bits is attached to each Code Block (otherwise L = 0 Bit).</p>							

Table A.3.8.2-3: Fixed Reference Channel 64QAM R=2/3

Parameter	PMCH						
	Unit	Value					
Reference channel				R.39-1TDD	R.39 TDD		
Channel bandwidth	MHz	1.4	3	5	10	15	20
Allocated resource blocks				25	50		
Uplink-Downlink Configuration(Note 1)				5	5		
Allocated subframes per Radio Frame				5	5		
Modulation				64QAM	64QAM		
Target Coding Rate				2/3	2/3		
Information Bit Payload (Note 2)							
For Sub-Frames 3,4,7,8,9	Bits			9912	19848		
For Sub-Frames 0,1,2,5,6	Bits			n/a	n/a		
Number of Code Blocks per Sub-Frame (Note 3)				2	4		
Binary Channel Bits Per Subframe							
For Sub-Frames 3,4,7,8,9	Bits			15300	30600		
For Sub-Frames 0,1,2,5,6	Bits			n/a	n/a		
MBMS UE Category				≥ 1	≥ 2		
<p>Note 1: For TDD mode, in line with TS 36.331, Uplink-Downlink Configuration 5 is proposed, up to 5 subframes (#3/4/7/8/9) are available for MBMS.</p> <p>Note 2: 2 OFDM symbols are reserved for PDCCH; reference signal allocated as per TS 36.211.</p> <p>Note 3: If more than one Code Block is present, an additional CRC sequence of L = 24 Bits is attached to each Code Block (otherwise L = 0 Bit).</p>							

A.3.9 Reference measurement channels for sustained downlink data rate provided by lower layers

A.3.9.1 FDD

Table A.3.9.1-1: Fixed Reference Channel for sustained data-rate test (FDD)

Parameter	Unit	Value						
		R.31-1 FDD	R.31-2 FDD	R.31-3 FDD	R.31-3A FDD	R.31-3C FDD	R.31-4 FDD	R.31-4B FDD
Reference channel								
Channel bandwidth	MHz	10	10	20	10	15	20	15
Allocated resource blocks (Note 8)		Note 5	Note 6	Note 7	Note 6	Note 9	Note 7	Note 10
Allocated subframes per Radio Frame		10	10	10	10	10	10	10
Modulation		64QAM	64QAM	64QAM	64QAM	64QAM	64QAM	64QAM
Coding Rate								
For Sub-Frame 1,2,3,4,6,7,8,9,		0.40	0.59	0.59	0.85	0.87	0.88	0.85
For Sub-Frame 5		0.40	0.64	0.62	0.89	0.88	0.87	0.87
For Sub-Frame 0		0.40	0.63	0.61	0.90	0.91	0.90	0.88
Information Bit Payload (Note 8)								
For Sub-Frames 1,2,3,4,6,7,8,9	Bits	10296	25456	51024	36696	51024	75376	55056
For Sub-Frame 5	Bits	10296	25456	51024	35160	51024	71112	52752
For Sub-Frame 0	Bits	10296	25456	51024	36696	51024	75376	55056
Number of Code Blocks (Notes 3 and 8)								
For Sub-Frames 1,2,3,4,6,7,8,9	Bits	2	5	9	6	9	13	9
For Sub-Frame 5	Bits	2	5	9	6	9	12	9
For Sub-Frame 0	Bits	2	5	9	6	9	13	9
Binary Channel Bits (Note 8)								
For Sub-Frames 1,2,3,4,6,7,8,9	Bits	26100	43200	86400	43200	58752	86400	64800
For Sub-Frame 5	Bits	26100	39744	82080	39744	57888	82080	60480
For Sub-Frame 0	Bits	26100	40752	83952	40752	56304	83952	62352
Number of layers		1	2	2	2	2	2	2
Max. Throughput averaged over 1 frame (Note 8)	Mbps	10.296	25.456	51.024	36.542	51.024	74.950	54.826
UE Categories		≥ 1	≥ 2	≥ 2	≥ 2	≥ 3	≥ 3	≥ 4
<p>Note 1: 1 symbol allocated to PDCCH for all tests.</p> <p>Note 2: Reference signal, synchronization signals and PBCH allocated as per TS 36.211 [4].</p> <p>Note 3: If more than one Code Block is present, an additional CRC sequence of L = 24 Bits is attached to each Code Block (otherwise L = 0 Bit).</p> <p>Note 4: Resource blocks $n_{PRB} = 0..2$ are allocated for SIB transmissions in sub-frame 5 for all bandwidths.</p> <p>Note 5: Resource blocks $n_{PRB} = 6..14,30..49$ are allocated for the user data in all sub-frames.</p> <p>Note 6: Resource blocks $n_{PRB} = 3..49$ are allocated for the user data in sub-frame 5, and resource blocks $n_{PRB} = 0..49$ in sub-frames 0,1,2,3,4,6,7,8,9.</p> <p>Note 7: Resource blocks $n_{PRB} = 4..99$ are allocated for the user data in sub-frame 5, and resource blocks $n_{PRB} = 0..99$ in sub-frames 0,1,2,3,4,6,7,8,9.</p> <p>Note 8: Given per component carrier per codeword.</p> <p>Note 9: Resource blocks $n_{PRB} = 4..71$ are allocated for the user data in sub-frames 0,1,2,3,4,5,6,7,8,9.</p> <p>Note 10: Resource blocks $n_{PRB} = 4..74$ are allocated for the user data in sub-frame 5, and resource blocks $n_{PRB} = 0..74$ in sub-frames 0,1,2,3,4,6,7,8,9.</p>								

A.3.9.2 TDD

Table A.3.9.2-1: Fixed Reference Channel for sustained data-rate test (TDD)

Parameter	Unit	Value				
		R.31-1 TDD	R.31-2 TDD	R.31-3 TDD	R.31-3A TDD	R.31-4 TDD
Reference channel						
Channel bandwidth	MHz	10	10	20	15	20
Allocated resource blocks		Note 6	Note 7	Note 8	Note 9	Note 8
Uplink-Downlink Configuration (Note 3)		5	5	5	1	1
Number of HARQ Processes per component carrier	Processes	15	15	15	7	7
Allocated subframes per Radio Frame (D+S)		8+1	8+1	8+1	4	4
Modulation		64QAM	64QAM	64QAM	64QAM	64QAM
Target Coding Rate						
For Sub-Frames 4,9		0.40	0.59	0.59	0.87	0.88
For Sub-Frames 3,7,8		0.40	0.59	0.59	n/a	n/a
For Sub-Frames 1		n/a	n/a	n/a	n/a	n/a
For Sub-Frames 5		0.40	0.64	0.62	0.88	0.87
For Sub-Frames 6		0.40	0.60	0.60	n/a	n/a
For Sub-Frames 0		0.40	0.62	0.61	0.90	0.90
Information Bit Payload						
For Sub-Frames 4,9	Bits	10296	25456	51024	51024	75376
For Sub-Frames 3,7,8	Bits	10296	25456	51024	0	0
For Sub-Frame 1	Bits	0	0	0	0	0
For Sub-Frame 5	Bits	10296	25456	51024	51024	71112
For Sub-Frame 6	Bits	10296	25456	51024	0	0
For Sub-Frame 0	Bits	10296	25456	51024	51024	75376
Number of Code Blocks per Sub-Frame (Note 4)						
For Sub-Frames 4,9		2	5	9	9	13
For Sub-Frames 3,7,8		2	5	9	n/a	n/a
For Sub-Frame 1		n/a	n/a	n/a	n/a	n/a
For Sub-Frame 5		2	5	9	9	12
For Sub-Frame 6	Bits	2	5	9	n/a	n/a
For Sub-Frame 0		2	5	9	9	13
Binary Channel Bits Per Sub-Frame						
For Sub-Frames 4,9	Bits	26100	43200	86400	58752	86400
For Sub-Frames 3,7,8	Bits	26100	43200	86400	0	0
For Sub-Frame 1	Bits	0	0	0	0	0
For Sub-Frame 5	Bits	26100	40176	82512	58320	82512
For Sub-Frame 6	Bits	26100	42768	85968	n/a	n/a
For Sub-Frame 0	Bits	26100	41184	84384	56736	84384
Number of layers		1	2	2	2	2
Max. Throughput averaged over 1 frame (Note 10)	Mbps	8.237	20.365	40.819	20.409	29.724
UE Category		≥ 1	≥ 2	≥ 2	≥ 2	≥ 3
<p>Note 1: 1 symbol allocated to PDCCH for all tests.</p> <p>Note 2: Reference signal, synchronization signals and PBCH allocated as per TS 36.211 [4].</p> <p>Note 3: As per Table 4.2-2 in TS 36.211 [4].</p> <p>Note 4: If more than one Code Block is present, an additional CRC sequence of L = 24 Bits is attached to each Code Block (otherwise L = 0 Bit).</p> <p>Note 5: Resource blocks $n_{PRB} = 0..2$ are allocated for SIB transmissions in sub-frame 5 for all bandwidths.</p> <p>Note 6: Resource blocks $n_{PRB} = 6..14,30..49$ are allocated for the user data in all subframes.</p> <p>Note 7: Resource blocks $n_{PRB} = 3..49$ are allocated for the user data in sub-frame 5, and resource blocks $n_{PRB} = 0..49$ in sub-frames 0,3,4,6,7,8,9.</p> <p>Note 8: Resource blocks $n_{PRB} = 4..99$ are allocated for the user data in sub-frame 5, and resource blocks $n_{PRB} = 0..99$ in sub-frames 0,3,4,6,7,8,9.</p> <p>Note 9: Resource blocks $n_{PRB} = 4..71$ are allocated for the user data in all sub-frames</p> <p>Note 10: Given per component carrier per codeword.</p>						

A.4 CSI reference measurement channels

This section defines the DL signal applicable to the reporting of channel status information (Clause 9.2, 9.3 and 9.5).

In Table A.4-1 are specified the reference channels. Table A.4-15 specifies the mapping of CQI index to modulation coding scheme, which complies with the CQI definition specified in Section 7.2.3 of [6].

Table A.4-0: Void

Table A.4-1: CSI reference measurement channels

RMC Name	Duple x	CH-BW	Alloc. RB-s	UL/DL Config	Alloc. SF-s	MCS Scheme	Nr. HARQ Proc.	Max. nr HARQ Trans.	Notes
1 CRS Port									
RC.1 FDD	FDD	10	50	-		MCS.1	8	1	
RC.1 TDD	TDD	10	50	Note 3		MCS.1	10	1	
RC.3 FDD	FDD	10	6	-		MCS.10	8	1	
RC.3 TDD	TDD	10	6	Note 3		MCS.10	10	1	
RC.4 FDD	FDD	10	15	-		MCS.15	8	1	Note 6
RC.4 TDD	TDD	10	15	Note 3		MCS.15	10	1	Note 6
RC.5 FDD	FDD	10	3	-		MCS.17	8	1	
RC.5 TDD	TDD	10	3	Note 3		MCS.17	10	1	
2 CRS Ports									
RC.2 FDD	FDD	10	50	-		MCS.2	8	1	
RC.2 TDD	TDD	10	50	Note 3		MCS.2	10	1	
RC.6 FDD	FDD	10	15	-		MCS.16	8	1	Note 6
RC.6 TDD	TDD	10	15	Note 3		MCS.16	10	1	Note 6
1 CRS Port + CSI-RS									
RC.8 FDD	FDD	10	6	-	Non CSI-RS	MCS.11	8	1	
					2 CSI-RS	MCS.12			
RC.8 TDD	TDD	10	6	Note 3	Non CSI-RS	MCS.11	10	1	
					2 CSI-RS	MCS.12			
RC.9 FDD	FDD	10	50	-	Non CSI-RS	MCS.3	8	1	
					2 CSI-RS	MCS.4			
RC.9 TDD	TDD	10	50	Note 3	Non CSI-RS	MCS.3	10	1	
					2 CSI-RS	MCS.4			
2 CRS Port + CSI-RS									
RC.7 FDD	FDD	10	50	-	Non CSI-RS	MCS.5	8	1	
					4 CSI-RS	MCS.7			
RC.7 TDD	TDD	10	50	Note 3	Non CSI-RS	MCS.5	10	1	
					8 CSI-RS	MCS.8			
<p>Note 1: 3 symbols allocated to PDCCH.</p> <p>Note 2: For FDD only subframes 1, 2, 3, 4, 6, 7, 8 and 9 are allocated to avoid PBCH and synchronization signal overhead.</p> <p>Note 3: TDD UL-DL configuration as specified in the individual tests.</p> <p>Note 4: For TDD when UL-DL configuration 1 is used only subframes 4 and 9 are allocated to avoid PBCH and synchronization signal overhead.</p> <p>Note 5: For TDD when UL-DL configuration 2 is used only subframes 3, 4, 8, and 9 are allocated to avoid PBCH and synchronization signal overhead.</p> <p>Note 6: Centered within the Transmission Bandwidth Configuration (Figure 5.6-1).</p>									

Table A.4-1a: Void

Table A.4-1b: Void

Table A.4-2: Void

Table A.4-2a: Void

Table A.4-2b: Void

Table A.4-3: Void

Table A.4-3a: Void

Table A.4-3b: Void

Table A.4-3c: Void

Table A.4-3d: Void

Table A.4-3e: Void

Table A.4-3f: Void

Table A.4-3g: Void

Table A.4-4: Void

Table A.4-4a: Void

Table A.4-5: Void

Table A.4-5a: Void

Table A.4-6: Void

Table A.4-6a: Void

Table A.4-6b: Void

Table A.4-7: Void

Table A.4-8: Void

Table A.4-9: Void

Table A.4-10: Void

Table A.4-11: Void

Table A.4-12: Void

Table A.4-13: Void

Table A.14: Void

Table A.4-15: Mapping of CQI Index to Modulation coding scheme (MCS)

CQI Index			0	1	2	3	4	5	6	7	8	9	10	11	12	13	14	15	Notes
Target Coding Rate			OOR	0.0762	0.1172	0.1885	0.3008	0.4385	0.5879	0.3691	0.4785	0.6016	0.4551	0.5537	0.6504	0.7539	0.8525	0.9258	
Modulation			OOR	QPSK						16QAM			64QAM						
MCS Scheme	PRB	Available RE-s	Imcs																
MCS.1	50	6300	DTX	0	0	2	4	6	8	11	13	16	18	21	23	25	27	27	
MCS.2	50	6000	DTX	0	0	2	4	6	8	11	13	15	18	20	22	24	26	27	
MCS.3	50	5700	DTX	0	0	2	4	6	8	10	13	15	17	19	21	23	25	26	
MCS.4	50	5600	DTX	0	0	2	4	6	7	10	12	14	17	19	21	23	25	26	
MCS.5	50	5400	DTX	0	0	2	3	5	7	10	12	14	17	19	21	23	24	25	
MCS.6	50	5300	DTX	0	0	1	3	5	7	10	12	14	17	19	21	22	24	25	
MCS.7	50	5200	DTX	0	0	1	3	5	7	10	12	14	17	18	20	22	24	25	
MCS.8	50	5000	DTX	0	0	1	3	5	7	10	12	13	17	18	20	22	23	24	
MCS.9	50	4800	DTX	0	0	1	3	5	7	10	12	13	17	18	20	22	23	24	
MCS.10	6	756	DTX	0	0	2	4	6	8	11	13	16	19	21	23	25	27	27	
MCS.11	6	684	DTX	0	0	2	4	6	8	11	13	14	17	20	21	23	25	27	
MCS.12	6	672	DTX	0	0	1	4	6	8	10	12	14	17	19	21	23	25	26	
MCS.13	6	648	DTX	0	0	2	4	6	8	11	13	15	18	20	22	24	26	27	
MCS.14	25	3150	DTX	0	0	2	4	6	8	11	13	16	18	21	23	25	27	27	
MCS.15	15	1890	DTX	0	0	2	4	6	8	11	13	16	18	21	23	25	27	27	
MCS.16	15	1800	DTX	0	0	2	4	6	8	11	13	15	18	20	22	24	26	27	
MCS.17	3	378	DTX	0	1	2	5	7	9	12	13	16	19	21	23	25	27	27	
Note 1:			Mapping between Imcs and TBS according to Tables 7.1.7.1-1 and 7.1.7.2.1-1 in TS 36.213 [6].																
Note 2:			3 symbols allocated to PDCCH.																
Note 3:			Sub-frame#0 and #5 are not used for the corresponding requirement. The next subframe (i.e. sub-frame#1 or #6) shall be used for potential retransmissions.																

A.5 OFDMA Channel Noise Generator (OCNG)

A.5.1 OCNG Patterns for FDD

The following OCNG patterns are used for modelling allocations to virtual UEs (which are not under test) and/or allocations used for MBSFN. The OCNG pattern for each sub frame specifies the allocations that shall be filled with OCNG, and furthermore, the relative power level of each such allocation.

In each test case the OCNG is expressed by parameters OCNG_RA and OCNG_RB which together with a relative power level (γ) specifies the PDSCH EPRE-to-RS EPRE ratios in OFDM symbols with and without reference symbols, respectively. The relative power, which is used for modelling boosting per virtual UE allocation, is expressed by:

$$\gamma_i = PDSCH_{i_RA} / OCNG_RA = PDSCH_{i_RB} / OCNG_RB,$$

where γ_i denotes the relative power level of the i :th virtual UE. The parameter settings of OCNG_RA, OCNG_RB, and the set of relative power levels γ are chosen such that when also taking allocations to the UE under test into account, as given by a PDSCH reference channel, a constant transmitted power spectral density that is constant on an OFDM symbol basis is targeted.

Moreover the OCNG pattern is accompanied by a PCFICH/PDCCH/PHICH reference channel which specifies the control region. For any aggregation and PHICH allocation, the PDCCH and any unused PHICH groups are padded with resource element groups with a power level given respectively by PDCCH_RA/RB and PHICH_RA/RB as specified in the test case such that a total power spectral density in the control region that is constant on an OFDM symbol basis is targeted.

For the performance requirements of UE with the CA capability, the OCNG patterns apply for each CC.

A.5.1.1 OCNG FDD pattern 1: One sided dynamic OCNG FDD pattern

This OCNG Pattern fills with OCNG all empty PRB-s (PRB-s with no allocation of data or system information) of the DL sub-frames, when the unallocated area is continuous in frequency domain (one sided).

Table A.5.1.1-1: OP.1 FDD: One sided dynamic OCNG FDD Pattern

Relative power level γ_{PRB} [dB]			PDSCH Data
Subframe			
0	5	1 – 4, 6 – 9	
Allocation			
First unallocated PRB – Last unallocated PRB	First unallocated PRB – Last unallocated PRB	First unallocated PRB – Last unallocated PRB	
0	0	0	Note 1
<p>Note 1: These physical resource blocks are assigned to an arbitrary number of virtual UEs with one PDSCH per virtual UE; the data transmitted over the OCNG PDSCHs shall be uncorrelated pseudo random data, which is QPSK modulated. The parameter γ_{PRB} is used to scale the power of PDSCH.</p> <p>Note 2: If two or more transmit antennas with CRS are used in the test, the OCNG shall be transmitted to the virtual users by all the transmit antennas with CRS according to transmission mode 2. The parameter γ_{PRB} applies to each antenna port separately, so the transmit power is equal between all the transmit antennas with CRS used in the test. The antenna transmission modes are specified in section 7.1 in 3GPP TS 36.213.</p>			

A.5.1.2 OCNG FDD pattern 2: Two sided dynamic OCNG FDD pattern

This OCNG Pattern fills with OCNG all empty PRB-s (PRB-s with no allocation of data or system information) of the DL sub-frames, when the unallocated area is discontinuous in frequency domain (divided in two parts by the allocated area – two sided), starts with PRB 0 and ends with PRB $N_{RB} - 1$.

Table A.5.1.2-1: OP.2 FDD: Two sided dynamic OCNG FDD Pattern

Relative power level γ_{PRB} [dB]			PDSCH Data
Subframe			
0	5	1 – 4, 6 – 9	
Allocation			
0 – (First allocated PRB-1) and (Last allocated PRB+1) – ($N_{RB} - 1$)	0 – (First allocated PRB-1) and (Last allocated PRB+1) – ($N_{RB} - 1$)	0 – (First allocated PRB-1) and (Last allocated PRB+1) – ($N_{RB} - 1$)	
0	0	0	Note 1
<p>Note 1: These physical resource blocks are assigned to an arbitrary number of virtual UEs with one PDSCH per virtual UE; the data transmitted over the OCNG PDSCHs shall be uncorrelated pseudo random data, which is QPSK modulated. The parameter γ_{PRB} is used to scale the power of PDSCH.</p> <p>Note 2: If two or more transmit antennas with CRS are used in the test, the OCNG shall be transmitted to the virtual users by all the transmit antennas with CRS according to transmission mode 2. The parameter γ_{PRB} applies to each antenna port separately, so the transmit power is equal between all the transmit antennas with CRS used in the test. The antenna transmission modes are specified in section 7.1 in 3GPP TS 36.213.</p>			

A.5.1.3 OCNG FDD pattern 3: 49 RB OCNG allocation with MBSFN in 10 MHz

Table A.5.1.3-1: OP.3 FDD: OCNG FDD Pattern 3

Allocation n_{PRB}	Relative power level γ_{PRB} [dB]				PDSCH Data	PMCH Data
	Subframe					
	0	5	4, 9	1 – 3, 6 – 8		
1 – 49	0	0 (Allocation: all empty PRB-s)	0	N/A	Note 1	N/A
0 – 49	N/A	N/A	N/A	0	N/A	Note 2
<p>Note 1: These physical resource blocks are assigned to an arbitrary number of virtual UEs with one PDSCH per virtual UE; the data transmitted over the OCNG PDSCHs shall be uncorrelated pseudo random data, which is QPSK modulated. The parameter γ_{PRB} is used to scale the power of PDSCH.</p> <p>Note 2: Each physical resource block (PRB) is assigned to MBSFN transmission. The data in each PRB shall be uncorrelated with data in other PRBs over the period of any measurement. The MBSFN data shall be QPSK modulated. PMCH subframes shall contain cell-specific Reference Signals only in the first symbol of the first time slot. The parameter γ_{PRB} is used to scale the power of PMCH.</p> <p>Note 3: If two or more transmit antennas are used in the test, the OCNG shall be transmitted to the virtual users by all the transmit antennas according to transmission mode 2. The transmit power shall be equally split between all the transmit antennas used in the test. The antenna transmission modes are specified in section 7.1 in 3GPP TS 36.213.</p> <p>N/A: Not Applicable</p>						

A.5.1.4 OCNG FDD pattern 4: One sided dynamic OCNG FDD pattern for MBMS transmission

This OCNG Pattern fills with OCNG all empty PRB-s (PRB-s with no allocation of data or system information) of the DL sub-frames, when the unallocated area is continuous in frequency domain (one sided) and MBMS performance is tested.

Table A.5.1.4-1: OP.4 FDD: One sided dynamic OCNG FDD Pattern for MBMS transmission

Allocation n_{PRB}	Relative power level γ_{PRB} [dB]			PDSCH Data	PMCH Data
	Subframe				
	0, 4, 9	5	1 – 3, 6 – 8		
First unallocated PRB – Last unallocated PRB	0	0 (Allocation: all empty PRB-s)	N/A	Note 1	N/A
First unallocated PRB – Last unallocated PRB	N/A	N/A	N/A	N/A	Note 2
<p>Note 1: These physical resource blocks are assigned to an arbitrary number of virtual UEs with one PDSCH per virtual UE; the data transmitted over the OCNG PDSCHs shall be uncorrelated pseudo random data, which is QPSK modulated. The parameter γ_{PRB} is used to scale the power of PDSCH.</p> <p>Note 2: Each physical resource block (PRB) is assigned to MBSFN transmission. The data in each PRB shall be uncorrelated with data in other PRBs over the period of any measurement. The MBSFN data shall be QPSK modulated. PMCH subframes shall contain cell-specific Reference Signals only in the first symbol of the first time slot. The parameter γ_{PRB} is used to scale the power of PMCH.</p> <p>Note 3: If two or more transmit antennas are used in the test, the OCNG shall be transmitted to the virtual users by all the transmit antennas according to transmission mode 2. The transmit power shall be equally split between all the transmit antennas used in the test. The antenna transmission modes are specified in section 7.1 in 3GPP TS 36.213.</p> <p>N/A: Not Applicable</p>					

A.5.1.5 OCNG FDD pattern 5: One sided dynamic 16QAM modulated OCNG FDD pattern

This OCNG Pattern fills with OCNG all empty PRB-s (PRB-s with no allocation of data or system information) of DL sub-frames, when the unallocated area is continuous in the frequency domain (one sided).

Table A.5.1.5-1: OP.5 FDD: One sided dynamic 16QAM modulated OCNG FDD Pattern

Relative power level γ_{PRB} [dB]			PDSCH Data
Subframe			
0	5	1 – 4, 6 – 9	
Allocation			
First unallocated PRB – Last unallocated PRB	First unallocated PRB – Last unallocated PRB	First unallocated PRB – Last unallocated PRB	
0	0	0	Note 1
<p>Note 1: These physical resource blocks are assigned to an arbitrary number of virtual UEs with one PDSCH per virtual UE; the data transmitted over the OCNG PDSCHs shall be uncorrelated pseudo random data, which is 16QAM modulated. The parameter γ_{PRB} is used to scale the power of PDSCH.</p> <p>Note 2: If two or more transmit antennas with CRS are used in the test, the OCNG shall be transmitted to the virtual users by all the transmit antennas with CRS according to transmission mode 3 (Large Delay CDD). The parameter γ_{PRB} applies to each antenna port separately, so the transmit power is equal between all the transmit antennas with CRS used in the test. The antenna transmission modes are specified in section 7.1 in 3GPP TS 36.213.</p>			

A.5.1.6 OCNG FDD pattern 6: dynamic OCNG FDD pattern when user data is in 2 non-contiguous blocks

This OCNG Pattern fills with OCNG all empty PRB-s (PRB-s with no allocation of data or system information) of the DL sub-frames, when the unallocated area is discontinuous in frequency domain (divided in two parts by the first allocated block). The second allocated block ends with PRB $N_{RB} - 1$.

Table A.5.1.6-1: OP.6 FDD: OCNG FDD Pattern when user data is in 2 non-contiguous blocks

Relative power level γ_{PRB} [dB]			PDSCH Data
Subframe			
0	5	1 – 4, 6 – 9	
Allocation			
0 – (First allocated PRB of first block -1) and (Last allocated PRB of first block +1) – (First allocated PRB of second block -1)	0 – (First allocated PRB of first block -1) and (Last allocated PRB of first block +1) – (First allocated PRB of second block -1)	0 – (First allocated PRB of first block -1) and (Last allocated PRB of first block +1) – (First allocated PRB of second block -1)	
0	0	0	Note 1
<p>Note 1: These physical resource blocks are assigned to an arbitrary number of virtual UEs with one PDSCH per virtual UE; the data transmitted over the OCNG PDSCHs shall be uncorrelated pseudo random data, which is QPSK modulated. The parameter γ_{PRB} is used to scale the power of PDSCH.</p> <p>Note 2: If two or more transmit antennas with CRS are used in the test, the OCNG shall be transmitted to the virtual users by all the transmit antennas with CRS according to transmission mode 2. The parameter γ_{PRB} applies to each antenna port separately, so the transmit power is equal between all the transmit antennas with CRS used in the test. The antenna transmission modes are specified in section 7.1 in 3GPP TS 36.213.</p>			

A.5.1.7 OCNG FDD pattern 7: dynamic OCNG FDD pattern when user data is in multiple non-contiguous blocks

This OCNG Pattern fills with OCNG all empty PRB-s (PRB-s with no allocation of data, EPDCCH or system information) of the DL sub-frames, when the unallocated area is discontinuous in frequency domain (divided in multiple parts by the M allocated blocks for data transmission). The m -th allocated block starts with PRB $N_{Start,m}$ and ends with PRB $N_{End,m} - 1$, where $m = 1, \dots, M$. The system bandwidth starts with PRB 0 and ends with $N_{RB} - 1$.

Table A.5.1.7-1: OP.7 FDD: OCNG FDD Pattern when user data is in multiple non-contiguous blocks

Relative power level γ_{PRB} [dB]			PDSCH Data
Subframe			
0	5	1-4, 6-9	
Allocation			
0 – (PRB $N_{Start,1} - 1$) ... (PRB $N_{End,(m-1)} - 1$) – (PRB $N_{Start,m} - 1$) ... (PRB $N_{End,M} - 1$) – (PRB $N_{RB} - 1$)	0 – (PRB $N_{Start,1} - 1$) ... (PRB $N_{End,(m-1)} - 1$) – (PRB $N_{Start,m} - 1$) ... (PRB $N_{End,M} - 1$) – (PRB $N_{RB} - 1$)	0 – (PRB $N_{Start,1} - 1$) ... (PRB $N_{End,(m-1)} - 1$) – (PRB $N_{Start,m} - 1$) ... (PRB $N_{End,M} - 1$) – (PRB $N_{RB} - 1$)	
0	0	0	Note 1
Note 1: These physical resource blocks are assigned to an arbitrary number of virtual UEs with one PDSCH per virtual UE; the data transmitted over the OCNG PDSCHs shall be uncorrelated pseudo random data, which is QPSK modulated. The parameter γ_{PRB} is used to scale the power of PDSCH.			
Note 2: If two or more transmit antennas with CRS are used in the test, the OCNG shall be transmitted to the virtual users by all the transmit antennas with CRS according to transmission mode 2. The parameter γ_{PRB} applies to each antenna port separately, so the transmit power is equal between all the transmit antennas with CRS used in the test. The antenna transmission modes are specified in section 7.1 in 3GPP TS 36.213.			

A.5.2 OCNG Patterns for TDD

The following OCNG patterns are used for modelling allocations to virtual UEs (which are not under test). The OCNG pattern for each sub frame specifies the allocations that shall be filled with OCNG, and furthermore, the relative power level of each such allocation.

In each test case the OCNG is expressed by parameters OCNG_RA and OCNG_RB which together with a relative power level (γ) specifies the PDSCH EPRE-to-RS EPRE ratios in OFDM symbols with and without reference symbols, respectively. The relative power, which is used for modelling boosting per virtual UE allocation, is expressed by:

$$\gamma_i = PDSCH_i_RA / OCNG_RA = PDSCH_i_RB / OCNG_RB,$$

where γ_i denotes the relative power level of the i :th virtual UE. The parameter settings of OCNG_RA, OCNG_RB, and the set of relative power levels γ are chosen such that when also taking allocations to the UE under test into account, as given by a PDSCH reference channel, a transmitted power spectral density that is constant on an OFDM symbol basis is targeted.

Moreover the OCNG pattern is accompanied by a PCFICH/PDCCH/PHICH reference channel which specifies the control region. For any aggregation and PHICH allocation, the PDCCH and any unused PHICH groups are padded with resource element groups with a power level given respectively by PDCCH_RA/RB and PHICH_RA/RB as specified in the test case such that a total power spectral density in the control region that is constant on an OFDM symbol basis is targeted.

A.5.2.1 OCNG TDD pattern 1: One sided dynamic OCNG TDD pattern

This OCNG Pattern fills with OCNG all empty PRB-s (PRB-s with no allocation of data or system information) of the subframes available for DL transmission (depending on TDD UL/DL configuration), when the unallocated area is continuous in frequency domain (one sided).

Table A.5.2.1-1: OP.1 TDD: One sided dynamic OCNG TDD Pattern

Relative power level γ_{PRB} [dB]				PDSCH Data
Subframe (only if available for DL)				
0	5	3, 4, 7, 8, 9 and 6 (as normal subframe) ^{Note 2}	1 and 6 (as special subframe) ^{Note 2}	
Allocation				
First unallocated PRB – Last unallocated PRB	First unallocated PRB – Last unallocated PRB	First unallocated PRB – Last unallocated PRB	First unallocated PRB – Last unallocated PRB	
0	0	0	0	Note 1
<p>Note 1: These physical resource blocks are assigned to an arbitrary number of virtual UEs with one PDSCH per virtual UE; the data transmitted over the OCNG PDSCHs shall be uncorrelated pseudo random data, which is QPSK modulated. The parameter γ_{PRB} is used to scale the power of PDSCH.</p> <p>Note 2: Subframes available for DL transmission depends on the Uplink-Downlink configuration in Table 4.2-2 in 3GPP TS 36.211</p> <p>Note 3: If two or more transmit antennas with CRS are used in the test, the OCNG shall be transmitted to the virtual users by all the transmit antennas with CRS according to transmission mode 2. The parameter γ_{PRB} applies to each antenna port separately, so the transmit power is equal between all the transmit antennas with CRS used in the test. The antenna transmission modes are specified in section 7.1 in 3GPP TS 36.213.</p>				

A.5.2.2 OCNG TDD pattern 2: Two sided dynamic OCNG TDD pattern

This OCNG Pattern fills with OCNG all empty PRB-s (PRB-s with no allocation of data or system information) of the subframes available for DL transmission (depending on TDD UL/DL configuration), when the unallocated area is discontinuous in frequency domain (divided in two parts by the allocated area – two sided), starts with PRB 0 and ends with PRB $N_{RB} - 1$.

Table A.5.2.2-1: OP.2 TDD: Two sided dynamic OCNG TDD Pattern

Relative power level γ_{PRB} [dB]				PDSCH Data
Subframe (only if available for DL)				
0	5	3, 4, 6, 7, 8, 9 (6 as normal subframe) <small>Note 2</small>	1, 6 (6 as special subframe) <small>Note 2</small>	
Allocation				
0 – (First allocated PRB-1) and (Last allocated PRB+1) – ($N_{RB} - 1$)	0 – (First allocated PRB-1) and (Last allocated PRB+1) – ($N_{RB} - 1$)	0 – (First allocated PRB-1) and (Last allocated PRB+1) – ($N_{RB} - 1$)	0 – (First allocated PRB-1) and (Last allocated PRB+1) – ($N_{RB} - 1$)	
0	0	0	0	Note 1
<p>Note 1: These physical resource blocks are assigned to an arbitrary number of virtual UEs with one PDSCH per virtual UE; the data transmitted over the OCNG PDSCHs shall be uncorrelated pseudo random data, which is QPSK modulated. The parameter γ_{PRB} is used to scale the power of PDSCH.</p> <p>Note 2: Subframes available for DL transmission depends on the Uplink-Downlink configuration in Table 4.2-2 in 3GPP TS 36.211</p> <p>Note 3: If two or more transmit antennas with CRS are used in the test, the OCNG shall be transmitted to the virtual users by all the transmit antennas with CRS according to transmission mode 2. The parameter γ_{PRB} applies to each antenna port separately, so the transmit power is equal between all the transmit antennas with CRS used in the test. The antenna transmission modes are specified in section 7.1 in 3GPP TS 36.213.</p>				

A.5.2.3 OCNG TDD pattern 3: 49 RB OCNG allocation with MBSFN in 10 MHz

Table A.5.2.3-1: OP.3 TDD: OCNG TDD Pattern 3 for 5ms downlink-to-uplink switch-point periodicity

Allocation n_{PRB}	Relative power level γ_{PRB} [dB]				PDSCH Data	PMCH Data
	Subframe					
	0	5	4, 9 ^{Note 2}	1, 6		
1 – 49	0	0 (Allocation: all empty PRB-s)	N/A	0	Note 1	N/A
0 – 49	N/A	N/A	0	N/A	N/A	Note 3
<p>Note 1: These physical resource blocks are assigned to an arbitrary number of virtual UEs with one PDSCH per virtual UE; the data transmitted over the OCNG PDSCHs shall be uncorrelated pseudo random data, which is QPSK modulated. The parameter γ_{PRB} is used to scale the power of PDSCH.</p> <p>Note 2: Subframes available for DL transmission depends on the Uplink-Downlink configuration in Table 4.2-2 in 3GPP TS 36.211.</p> <p>Note 3: Each physical resource block (PRB) is assigned to MBSFN transmission. The data in each PRB shall be uncorrelated with data in other PRBs over the period of any measurement. The MBSFN data shall be QPSK modulated. PMCH symbols shall not contain cell-specific Reference Signals.</p> <p>Note 4: If two or more transmit antennas are used in the test, the OCNG shall be transmitted to the virtual users by all the transmit antennas according to transmission mode 2. The transmit power shall be equally split between all the transmit antennas used in the test. The antenna transmission modes are specified in section 7.1 in 3GPP TS 36.213.</p>						
N/A	Not Applicable					

A.5.2.4 OCNG TDD pattern 4: One sided dynamic OCNG TDD pattern for MBMS transmission

This OCNG Pattern fills with OCNG all empty PRB-s (PRB-s with no allocation of data or system information) of the DL sub-frames, when the unallocated area is continuous in frequency domain (one sided) and MBMS performance is tested.

Table A.5.2.4-1: OP.4 TDD: One sided dynamic OCNG TDD Pattern for MBMS transmission

Allocation n_{PRB}	Relative power level γ_{PRB} [dB]				PDSCH Data	PMCH Data
	Subframe (only for DL)					
	0 and 6 (as normal subframe)	1 (as special subframe)	5	3, 4, 7 – 9		
First unallocated PRB – Last unallocated PRB	0	0 (Allocation: all empty PRB-s of DwPTS)	0 (Allocation: all empty PRB-s)	N/A	Note 1	N/A
First unallocated PRB – Last unallocated PRB	N/A	N/A	N/A	N/A	N/A	Note2
<p>Note 1: These physical resource blocks are assigned to an arbitrary number of virtual UEs with one PDSCH per virtual UE; the data transmitted over the OCNG PDSCHs shall be uncorrelated pseudo random data, which is QPSK modulated. The parameter γ_{PRB} is used to scale the power of PDSCH.</p> <p>Note 2: Each physical resource block (PRB) is assigned to MBSFN transmission. The data in each PRB shall be uncorrelated with data in other PRBs over the period of any measurement. The MBSFN data shall be QPSK modulated. PMCH symbols shall not contain cell-specific Reference Signals.</p> <p>Note 3: If two or more transmit antennas are used in the test, the OCNG shall be transmitted to the virtual users by all the transmit antennas according to transmission mode 2. The transmit power shall be equally split between all the transmit antennas used in the test. The antenna transmission modes are specified in section 7.1 in 3GPP TS 36.213.</p>						
N/A	Not Applicable					

A.5.2.5 OCNG TDD pattern 5: One sided dynamic 16QAM modulated OCNG TDD pattern

This OCNG Pattern fills with OCNG all empty PRB-s (PRB-s with no allocation of data or system information) of the sub-frames available for DL transmission (depending on TDD UL/DL configuration), when the unallocated area is continuous in frequency domain (one sided).

Table A.5.2.5-1: OP.5 TDD: One sided dynamic 16QAM modulated OCNG TDD Pattern

Relative power level γ_{PRB} [dB]				PDSCH Data
Subframe (only if available for DL)				
0	5	3, 4, 7, 8, 9 and 6 (as normal subframe) <small>Note 2</small>	1 and 6 (as special subframe) <small>Note 2</small>	
Allocation				
First unallocated PRB –	First unallocated PRB –	First unallocated PRB –	First unallocated PRB –	
Last unallocated PRB	Last unallocated PRB	Last unallocated PRB	Last unallocated PRB	
0	0	0	0	Note 1
<p>Note 1: These physical resource blocks are assigned to an arbitrary number of virtual UEs with one PDSCH per virtual UE; the data transmitted over the OCNG PDSCHs shall be uncorrelated pseudo random data, which is 16QAM modulated. The parameter γ_{PRB} is used to scale the power of PDSCH.</p> <p>Note 2: Subframes available for DL transmission depends on the Uplink-Downlink configuration in Table 4.2-2 in 3GPP TS 36.211</p> <p>Note 3: If two or more transmit antennas with CRS are used in the test, the OCNG shall be transmitted to the virtual users by all the transmit antennas with CRS according to transmission mode 3 (Large Delay CDD). The parameter γ_{PRB} applies to each antenna port separately, so the transmit power is equal between all the transmit antennas with CRS used in the test. The antenna transmission modes are specified in section 7.1 in 3GPP TS 36.213.</p>				

A.5.2.6 OCNG TDD pattern 6: dynamic OCNG TDD pattern when user data is in 2 non-contiguous blocks

This OCNG Pattern fills with OCNG all empty PRB-s (PRB-s with no allocation of data or system information) of the subframes available for DL transmission (depending on TDD UL/DL configuration), when the unallocated area is discontinuous in frequency domain (divided in two parts by the first allocated block). The second allocated block ends with PRB $N_{RB} - 1$.

Table A.5.2.6-1: OP.6 TDD: OCNG TDD Pattern when user data is in 2 non-contiguous blocks

Relative power level γ_{PRB} [dB]				PDSCH Data
Subframe (only if available for DL)				
0	5	3, 4, 6, 7, 8, 9 (6 as normal subframe) <small>Note 2</small>	1,6 (6 as special subframe) <small>Note 2</small>	
Allocation				
0 – (First allocated PRB of first block -1) and (Last allocated PRB of first block +1) – (First allocated PRB of second block -1)	0 – (First allocated PRB of first block -1) and (Last allocated PRB of first block +1) – (First allocated PRB of second block -1)	0 – (First allocated PRB of first block -1) and (Last allocated PRB of first block +1) – (First allocated PRB of second block -1)	0 – (First allocated PRB of first block -1) and (Last allocated PRB of first block +1) – (First allocated PRB of second block -1)	
0	0	0	0	
<p>Note 1: These physical resource blocks are assigned to an arbitrary number of virtual UEs with one PDSCH per virtual UE; the data transmitted over the OCNG PDSCHs shall be uncorrelated pseudo random data, which is QPSK modulated. The parameter γ_{PRB} is used to scale the power of PDSCH.</p> <p>Note 2: Subframes available for DL transmission depends on the Uplink-Downlink configuration in Table 4.2-2 in 3GPP TS 36.211</p> <p>Note 3: If two or more transmit antennas with CRS are used in the test, the OCNG shall be transmitted to the virtual users by all the transmit antennas with CRS according to transmission mode 2. The parameter γ_{PRB} applies to each antenna port separately, so the transmit power is equal between all the transmit antennas with CRS used in the test. The antenna transmission modes are specified in section 7.1 in 3GPP TS 36.213.</p>				

A.5.2.7 OCNG TDD pattern 7: dynamic OCNG TDD pattern when user data is in multiple non-contiguous blocks

This OCNG Pattern fills with OCNG all empty PRB-s (PRB-s with no allocation of data, EPDCCH or system information) of the DL sub-frames, when the unallocated area is discontinuous in frequency domain (divided in multiple parts by the M allocated blocks for data transmission). The m -th allocated block starts with RPB $N_{Start,m}$ and ends with PRB $N_{End,m} - 1$, where $m = 1, \dots, M$. The system bandwidth starts with RPB 0 and ends with $N_{RB} - 1$.

Table A.5.2.7-1: OP.7 TDD: OCNG TDD Pattern when user data is in multiple non-contiguous blocks

Relative power level γ_{PRB} [dB]				PDSCH Data
Subframe (only if available for DL)				
0	5	3, 4, 6, 7, 8, 9 (6 as normal subframe) Note 2	1,6 (6 as special subframe) Note 2	
Allocation				
0 – (PRB $N_{Start,1} - 1$) ... (PRB $N_{End,(m-1)} - 1$) – (PRB $N_{Start,m} - 1$) ... (PRB $N_{End,M} - 1$) – (PRB $N_{RB} - 1$)	0 – (PRB $N_{Start,1} - 1$) ... (PRB $N_{End,(m-1)} - 1$) – (PRB $N_{Start,m} - 1$) ... (PRB $N_{End,M} - 1$) – (PRB $N_{RB} - 1$)	0 – (PRB $N_{Start,1} - 1$) ... (PRB $N_{End,(m-1)} - 1$) – (PRB $N_{Start,m} - 1$) ... (PRB $N_{End,M} - 1$) – (PRB $N_{RB} - 1$)	0 – (PRB $N_{Start,1} - 1$) ... (PRB $N_{End,(m-1)} - 1$) – (PRB $N_{Start,m} - 1$) ... (PRB $N_{End,M} - 1$) – (PRB $N_{RB} - 1$)	
0	0	0	0	Note 1
<p>Note 1: These physical resource blocks are assigned to an arbitrary number of virtual UEs with one PDSCH per virtual UE; the data transmitted over the OCNG PDSCHs shall be uncorrelated pseudo random data, which is QPSK modulated. The parameter γ_{PRB} is used to scale the power of PDSCH.</p> <p>Note 2: Subframes available for DL transmission depends on the Uplink-Downlink configuration in Table 4.2-2 in 3GPP TS 36.211</p> <p>Note 3: If two or more transmit antennas with CRS are used in the test, the OCNG shall be transmitted to the virtual users by all the transmit antennas with CRS according to transmission mode 2. The parameter γ_{PRB} applies to each antenna port separately, so the transmit power is equal between all the transmit antennas with CRS used in the test. The antenna transmission modes are specified in section 7.1 in 3GPP TS 36.213.</p>				

Annex B (normative): Propagation conditions

B.1 Static propagation condition

For 1 port transmission the channel matrix is defined in the frequency domain by

$$\mathbf{H} = \begin{pmatrix} 1 \\ 1 \end{pmatrix}.$$

For 2 port transmission the channel matrix is defined in the frequency domain by

$$\mathbf{H} = \begin{pmatrix} 1 & j \\ 1 & -j \end{pmatrix}.$$

For 4 port transmission the channel matrix is defined in the frequency domain by

$$\mathbf{H} = \begin{bmatrix} 1 & 1 & j & j \\ 1 & 1 & -j & -j \end{bmatrix}$$

For 8 port transmission the channel matrix is defined in the frequency domain by

$$\mathbf{H} = \begin{bmatrix} 1 & 1 & 1 & 1 & j & j & j & j \\ 1 & 1 & 1 & 1 & -j & -j & -j & -j \end{bmatrix}$$

B.2 Multi-path fading propagation conditions

The multipath propagation conditions consist of several parts:

- A delay profile in the form of a "tapped delay-line", characterized by a number of taps at fixed positions on a sampling grid. The profile can be further characterized by the r.m.s. delay spread and the maximum delay spanned by the taps.
- A combination of channel model parameters that include the Delay profile and the Doppler spectrum, that is characterized by a classical spectrum shape and a maximum Doppler frequency
- A set of correlation matrices defining the correlation between the UE and eNodeB antennas in case of multi-antenna systems.
- Additional multi-path models used for CQI (Channel Quality Indication) tests

B.2.1 Delay profiles

The delay profiles are selected to be representative of low, medium and high delay spread environments. The resulting model parameters are defined in Table B.2.1-1 and the tapped delay line models are defined in Tables B.2.1-2, B.2.1-3 and B.2.1-4.

Table B.2.1-1 Delay profiles for E-UTRA channel models

Model	Number of channel taps	Delay spread (r.m.s.)	Maximum excess tap delay (span)
Extended Pedestrian A (EPA)	7	43 ns	410 ns
Extended Vehicular A model (EVA)	9	357 ns	2510 ns
Extended Typical Urban model (ETU)	9	991 ns	5000 ns

Table B.2.1-2 Extended Pedestrian A model (EPA)

Excess tap delay [ns]	Relative power [dB]
0	0.0
30	-1.0
70	-2.0
90	-3.0
110	-8.0
190	-17.2
410	-20.8

Table B.2.1-3 Extended Vehicular A model (EVA)

Excess tap delay [ns]	Relative power [dB]
0	0.0
30	-1.5
150	-1.4
310	-3.6
370	-0.6
710	-9.1
1090	-7.0
1730	-12.0
2510	-16.9

Table B.2.1-4 Extended Typical Urban model (ETU)

Excess tap delay [ns]	Relative power [dB]
0	-1.0
50	-1.0
120	-1.0
200	0.0
230	0.0
500	0.0
1600	-3.0
2300	-5.0
5000	-7.0

B.2.2 Combinations of channel model parameters

Table B.2.2-1 shows propagation conditions that are used for the performance measurements in multi-path fading environment for low, medium and high Doppler frequencies

Table B.2.2-1 Channel model parameters

Model	Maximum Doppler frequency
EPA 5Hz	5 Hz
EVA 5Hz	5 Hz
EVA 70Hz	70 Hz
ETU 30Hz	30 Hz
ETU 70Hz	70 Hz
ETU 300Hz	300 Hz

B.2.3 MIMO Channel Correlation Matrices

The MIMO channel correlation matrices defined in B.2.3 apply for the antenna configuration using uniform linear arrays at both eNodeB and UE.

B.2.3.1 Definition of MIMO Correlation Matrices

Table B.2.3.1-1 defines the correlation matrix for the eNodeB

Table B.2.3.1-1 eNodeB correlation matrix

	One antenna	Two antennas	Four antennas
eNode B Correlation	$R_{eNB} = 1$	$R_{eNB} = \begin{pmatrix} 1 & \alpha \\ \alpha^* & 1 \end{pmatrix}$	$R_{eNB} = \begin{pmatrix} 1 & \alpha^{1/9} & \alpha^{4/9} & \alpha \\ \alpha^{1/9*} & 1 & \alpha^{1/9} & \alpha^{4/9} \\ \alpha^{4/9*} & \alpha^{1/9*} & 1 & \alpha^{1/9} \\ \alpha^* & \alpha^{4/9*} & \alpha^{1/9*} & 1 \end{pmatrix}$

Table B.2.3.1-2 defines the correlation matrix for the UE:

Table B.2.3.1-2 UE correlation matrix

	One antenna	Two antennas	Four antennas
UE Correlation	$R_{UE} = 1$	$R_{UE} = \begin{pmatrix} 1 & \beta \\ \beta^* & 1 \end{pmatrix}$	$R_{UE} = \begin{pmatrix} 1 & \beta^{1/9} & \beta^{4/9} & \beta \\ \beta^{1/9*} & 1 & \beta^{1/9} & \beta^{4/9} \\ \beta^{4/9*} & \beta^{1/9*} & 1 & \beta^{1/9} \\ \beta^* & \beta^{4/9*} & \beta^{1/9*} & 1 \end{pmatrix}$

Table B.2.3.1-3 defines the channel spatial correlation matrix R_{spat} . The parameters, α and β in Table B.2.3.1-3 defines the spatial correlation between the antennas at the eNodeB and UE.

Table B.2.3.1-3: R_{spat} correlation matrices

1x2 case	$R_{spat} = R_{UE} = \begin{bmatrix} 1 & \beta \\ \beta^* & 1 \end{bmatrix}$
2x2 case	$R_{spat} = R_{eNB} \otimes R_{UE} = \begin{bmatrix} 1 & \alpha \\ \alpha^* & 1 \end{bmatrix} \otimes \begin{bmatrix} 1 & \beta \\ \beta^* & 1 \end{bmatrix} = \begin{bmatrix} 1 & \beta & \alpha & \alpha\beta \\ \beta^* & 1 & \alpha\beta^* & \alpha \\ \alpha^* & \alpha^*\beta & 1 & \beta \\ \alpha^*\beta^* & \alpha^* & \beta^* & 1 \end{bmatrix}$
4x2 case	$R_{spat} = R_{eNB} \otimes R_{UE} = \begin{bmatrix} 1 & \alpha^{1/9} & \alpha^{4/9} & \alpha \\ \alpha^{1/9*} & 1 & \alpha^{1/9} & \alpha^{4/9} \\ \alpha^{4/9*} & \alpha^{1/9*} & 1 & \alpha^{1/9} \\ \alpha^* & \alpha^{4/9*} & \alpha^{1/9*} & 1 \end{bmatrix} \otimes \begin{bmatrix} 1 & \beta \\ \beta^* & 1 \end{bmatrix}$
4x4 case	$R_{spat} = R_{eNB} \otimes R_{UE} = \begin{bmatrix} 1 & \alpha^{1/9} & \alpha^{4/9} & \alpha \\ \alpha^{1/9*} & 1 & \alpha^{1/9} & \alpha^{4/9} \\ \alpha^{4/9*} & \alpha^{1/9*} & 1 & \alpha^{1/9} \\ \alpha^* & \alpha^{4/9*} & \alpha^{1/9*} & 1 \end{bmatrix} \otimes \begin{bmatrix} 1 & \beta^{1/9} & \beta^{4/9} & \beta \\ \beta^{1/9*} & 1 & \beta^{1/9} & \beta^{4/9} \\ \beta^{4/9*} & \beta^{1/9*} & 1 & \beta^{1/9} \\ \beta^* & \beta^{4/9*} & \beta^{1/9*} & 1 \end{bmatrix}$

For cases with more antennas at either eNodeB or UE or both, the channel spatial correlation matrix can still be expressed as the Kronecker product of R_{eNB} and R_{UE} according to $R_{spat} = R_{eNB} \otimes R_{UE}$.

B.2.3.2 MIMO Correlation Matrices at High, Medium and Low Level

The α and β for different correlation types are given in Table B.2.3.2-1.

Table B.2.3.2-1

Low correlation		Medium Correlation		High Correlation	
α	β	α	β	α	β
0	0	0.3	0.9	0.9	0.9

The correlation matrices for high, medium and low correlation are defined in Table B.2.3.1-2, B.2.3.2-3 and B.2.3.2-4, as below.

The values in Table B.2.3.2-2 have been adjusted for the 4x2 and 4x4 high correlation cases to insure the correlation matrix is positive semi-definite after round-off to 4 digit precision. This is done using the equation:

$$\mathbf{R}_{high} = [\mathbf{R}_{spatial} + a\mathbf{I}_n] / (1 + a)$$

Where the value “a” is a scaling factor such that the smallest value is used to obtain a positive semi-definite result. For the 4x2 high correlation case, a=0.00010. For the 4x4 high correlation case, a=0.00012.

The same method is used to adjust the 4x4 medium correlation matrix in Table B.2.3.2-3 to insure the correlation matrix is positive semi-definite after round-off to 4 digit precision with a = 0.00012.

Table B.2.3.2-2: MIMO correlation matrices for high correlation

1x2 case	$R_{high} = \begin{pmatrix} 1 & 0.9 \\ 0.9 & 1 \end{pmatrix}$
2x2 case	$R_{high} = \begin{pmatrix} 1 & 0.9 & 0.9 & 0.81 \\ 0.9 & 1 & 0.81 & 0.9 \\ 0.9 & 0.81 & 1 & 0.9 \\ 0.81 & 0.9 & 0.9 & 1 \end{pmatrix}$
4x2 case	$R_{high} = \begin{bmatrix} 1.0000 & 0.8999 & 0.9883 & 0.8894 & 0.9542 & 0.8587 & 0.8999 & 0.8099 \\ 0.8999 & 1.0000 & 0.8894 & 0.9883 & 0.8587 & 0.9542 & 0.8099 & 0.8999 \\ 0.9883 & 0.8894 & 1.0000 & 0.8999 & 0.9883 & 0.8894 & 0.9542 & 0.8587 \\ 0.8894 & 0.9883 & 0.8999 & 1.0000 & 0.8894 & 0.9883 & 0.8587 & 0.9542 \\ 0.9542 & 0.8587 & 0.9883 & 0.8894 & 1.0000 & 0.8999 & 0.9883 & 0.8894 \\ 0.8587 & 0.9542 & 0.8894 & 0.9883 & 0.8999 & 1.0000 & 0.8894 & 0.9883 \\ 0.8999 & 0.8099 & 0.9542 & 0.8587 & 0.9883 & 0.8894 & 1.0000 & 0.8999 \\ 0.8099 & 0.8999 & 0.8587 & 0.9542 & 0.8894 & 0.9883 & 0.8999 & 1.0000 \end{bmatrix}$
4x4 case	$R_{high} = \begin{bmatrix} 1.0000 & 0.9882 & 0.9541 & 0.8999 & 0.9882 & 0.9767 & 0.9430 & 0.8894 & 0.9541 & 0.9430 & 0.9105 & 0.8587 & 0.8999 & 0.8894 & 0.8587 & 0.8099 \\ 0.9882 & 1.0000 & 0.9882 & 0.9541 & 0.9767 & 0.9882 & 0.9767 & 0.9430 & 0.9430 & 0.9541 & 0.9430 & 0.9105 & 0.8894 & 0.8999 & 0.8894 & 0.8587 \\ 0.9541 & 0.9882 & 1.0000 & 0.9882 & 0.9430 & 0.9767 & 0.9882 & 0.9767 & 0.9105 & 0.9430 & 0.9541 & 0.9430 & 0.8587 & 0.8894 & 0.8999 & 0.8894 \\ 0.8999 & 0.9541 & 0.9882 & 1.0000 & 0.8894 & 0.9430 & 0.9767 & 0.9882 & 0.8587 & 0.9105 & 0.9430 & 0.9541 & 0.8099 & 0.8587 & 0.8894 & 0.8999 \\ 0.9882 & 0.9767 & 0.9430 & 0.8894 & 1.0000 & 0.9882 & 0.9541 & 0.8999 & 0.9882 & 0.9767 & 0.9430 & 0.8894 & 0.9541 & 0.9430 & 0.9105 & 0.8587 \\ 0.9767 & 0.9882 & 0.9767 & 0.9430 & 0.9882 & 1.0000 & 0.9882 & 0.9541 & 0.9767 & 0.9882 & 0.9767 & 0.9430 & 0.9430 & 0.9541 & 0.9430 & 0.9105 \\ 0.9430 & 0.9767 & 0.9882 & 0.9767 & 0.9541 & 0.9882 & 1.0000 & 0.9882 & 0.9430 & 0.9767 & 0.9882 & 0.9767 & 0.9105 & 0.9430 & 0.9541 & 0.9430 \\ 0.8894 & 0.9430 & 0.9767 & 0.9882 & 0.8999 & 0.9541 & 0.9882 & 1.0000 & 0.8894 & 0.9430 & 0.9767 & 0.9882 & 0.8587 & 0.9105 & 0.9430 & 0.9541 \\ 0.9541 & 0.9430 & 0.9105 & 0.8587 & 0.9882 & 0.9767 & 0.9430 & 0.8894 & 1.0000 & 0.9882 & 0.9541 & 0.8999 & 0.9882 & 0.9767 & 0.9430 & 0.8894 \\ 0.9430 & 0.9541 & 0.9430 & 0.9105 & 0.9767 & 0.9882 & 0.9767 & 0.9430 & 0.9882 & 1.0000 & 0.9882 & 0.9541 & 0.9767 & 0.9882 & 0.9767 & 0.9430 \\ 0.9105 & 0.9430 & 0.9541 & 0.9430 & 0.9430 & 0.9767 & 0.9882 & 0.9767 & 0.9541 & 0.9882 & 1.0000 & 0.9882 & 0.9430 & 0.9767 & 0.9882 & 0.9767 \\ 0.8587 & 0.9105 & 0.9430 & 0.9541 & 0.8894 & 0.9430 & 0.9767 & 0.9882 & 0.8999 & 0.9541 & 0.9882 & 1.0000 & 0.8894 & 0.9430 & 0.9767 & 0.9882 \\ 0.8999 & 0.8894 & 0.8587 & 0.8099 & 0.9541 & 0.9430 & 0.9105 & 0.8587 & 0.9882 & 0.9767 & 0.9430 & 0.8894 & 1.0000 & 0.9882 & 0.9541 & 0.8999 \\ 0.8894 & 0.8999 & 0.8894 & 0.8587 & 0.9430 & 0.9541 & 0.9430 & 0.9105 & 0.9767 & 0.9882 & 0.9767 & 0.9430 & 0.9882 & 1.0000 & 0.9882 & 0.9541 \\ 0.8587 & 0.8894 & 0.8999 & 0.8894 & 0.9105 & 0.9430 & 0.9541 & 0.9430 & 0.9430 & 0.9767 & 0.9882 & 0.9767 & 0.9541 & 0.9882 & 1.0000 & 0.9882 \\ 0.8099 & 0.8587 & 0.8894 & 0.8999 & 0.8587 & 0.9105 & 0.9430 & 0.9541 & 0.8894 & 0.9430 & 0.9767 & 0.9882 & 0.8999 & 0.9541 & 0.9882 & 1.0000 \end{bmatrix}$

Table B.2.3.2-3: MIMO correlation matrices for medium correlation

case	N/A
case	$R_{medium} = \begin{pmatrix} 1 & 0.9 & 0.3 & 0.27 \\ 0.9 & 1 & 0.27 & 0.3 \\ 0.3 & 0.27 & 1 & 0.9 \\ 0.27 & 0.3 & 0.9 & 1 \end{pmatrix}$

case	$R_{medium} = \begin{pmatrix} 1.0000 & 0.9000 & 0.8748 & 0.7873 & 0.5856 & 0.5271 & 0.3000 & 0.2700 \\ 0.9000 & 1.0000 & 0.7873 & 0.8748 & 0.5271 & 0.5856 & 0.2700 & 0.3000 \\ 0.8748 & 0.7873 & 1.0000 & 0.9000 & 0.8748 & 0.7873 & 0.5856 & 0.5271 \\ 0.7873 & 0.8748 & 0.9000 & 1.0000 & 0.7873 & 0.8748 & 0.5271 & 0.5856 \\ 0.5856 & 0.5271 & 0.8748 & 0.7873 & 1.0000 & 0.9000 & 0.8748 & 0.7873 \\ 0.5271 & 0.5856 & 0.7873 & 0.8748 & 0.9000 & 1.0000 & 0.7873 & 0.8748 \\ 0.3000 & 0.2700 & 0.5856 & 0.5271 & 0.8748 & 0.7873 & 1.0000 & 0.9000 \\ 0.2700 & 0.3000 & 0.5271 & 0.5856 & 0.7873 & 0.8748 & 0.9000 & 1.0000 \end{pmatrix}$
case	$R_{medium} = \begin{pmatrix} 1.0000 & 0.9882 & 0.9541 & 0.8999 & 0.8747 & 0.8645 & 0.8347 & 0.7872 & 0.5855 & 0.5787 & 0.5588 & 0.5270 & 0.3000 & 0.2965 & 0.2862 & 0.2700 \\ 0.9882 & 1.0000 & 0.9882 & 0.9541 & 0.8645 & 0.8747 & 0.8645 & 0.8347 & 0.5787 & 0.5855 & 0.5787 & 0.5588 & 0.2965 & 0.3000 & 0.2965 & 0.2862 \\ 0.9541 & 0.9882 & 1.0000 & 0.9882 & 0.8347 & 0.8645 & 0.8747 & 0.8645 & 0.5588 & 0.5787 & 0.5855 & 0.5787 & 0.2862 & 0.2965 & 0.3000 & 0.2965 \\ 0.8999 & 0.9541 & 0.9882 & 1.0000 & 0.7872 & 0.8347 & 0.8645 & 0.8747 & 0.5270 & 0.5588 & 0.5787 & 0.5855 & 0.2700 & 0.2862 & 0.2965 & 0.3000 \\ 0.8747 & 0.8645 & 0.8347 & 0.7872 & 1.0000 & 0.9882 & 0.9541 & 0.8999 & 0.8747 & 0.8645 & 0.8347 & 0.7872 & 0.5855 & 0.5787 & 0.5588 & 0.5270 \\ 0.8645 & 0.8747 & 0.8645 & 0.8347 & 0.9882 & 1.0000 & 0.9882 & 0.9541 & 0.8645 & 0.8747 & 0.8645 & 0.8347 & 0.5787 & 0.5855 & 0.5787 & 0.5588 \\ 0.8347 & 0.8645 & 0.8747 & 0.8645 & 0.9541 & 0.9882 & 1.0000 & 0.9882 & 0.8347 & 0.8645 & 0.8747 & 0.8645 & 0.5588 & 0.5787 & 0.5855 & 0.5787 \\ 0.7872 & 0.8347 & 0.8645 & 0.8747 & 0.8999 & 0.9541 & 0.9882 & 1.0000 & 0.7872 & 0.8347 & 0.8645 & 0.8747 & 0.5270 & 0.5588 & 0.5787 & 0.5855 \\ 0.5855 & 0.5787 & 0.5588 & 0.5270 & 0.8747 & 0.8645 & 0.8347 & 0.7872 & 1.0000 & 0.9882 & 0.9541 & 0.8999 & 0.8747 & 0.8645 & 0.8347 & 0.7872 \\ 0.5787 & 0.5855 & 0.5787 & 0.5588 & 0.8645 & 0.8747 & 0.8645 & 0.8347 & 0.9882 & 1.0000 & 0.9882 & 0.9541 & 0.8645 & 0.8747 & 0.8645 & 0.8347 \\ 0.5588 & 0.5787 & 0.5855 & 0.5787 & 0.8347 & 0.8645 & 0.8747 & 0.8645 & 0.9541 & 0.9882 & 1.0000 & 0.9882 & 0.8347 & 0.8645 & 0.8747 & 0.8645 \\ 0.5270 & 0.5588 & 0.5787 & 0.5855 & 0.7872 & 0.8347 & 0.8645 & 0.8747 & 0.8999 & 0.9541 & 0.9882 & 1.0000 & 0.7872 & 0.8347 & 0.8645 & 0.8747 \\ 0.3000 & 0.2965 & 0.2862 & 0.2700 & 0.5855 & 0.5787 & 0.5588 & 0.5270 & 0.8747 & 0.8645 & 0.8347 & 0.7872 & 1.0000 & 0.9882 & 0.9541 & 0.8999 \\ 0.2965 & 0.3000 & 0.2965 & 0.2862 & 0.5787 & 0.5855 & 0.5787 & 0.5588 & 0.8645 & 0.8747 & 0.8645 & 0.8347 & 0.9882 & 1.0000 & 0.9882 & 0.9541 \\ 0.2862 & 0.2965 & 0.3000 & 0.2965 & 0.5588 & 0.5787 & 0.5855 & 0.5787 & 0.8347 & 0.8645 & 0.8747 & 0.8645 & 0.9541 & 0.9882 & 1.0000 & 0.9882 \\ 0.2700 & 0.2862 & 0.2965 & 0.3000 & 0.5270 & 0.5588 & 0.5787 & 0.5855 & 0.7872 & 0.8347 & 0.8645 & 0.8747 & 0.8999 & 0.9541 & 0.9882 & 1.0000 \end{pmatrix}$

Table B.2.3.2-4: MIMO correlation matrices for low correlation

1x2 case	$R_{low} = \mathbf{I}_2$
2x2 case	$R_{low} = \mathbf{I}_4$
4x2 case	$R_{low} = \mathbf{I}_8$
4x4 case	$R_{low} = \mathbf{I}_{16}$

In Table B.2.3.2-4, \mathbf{I}_d is the $d \times d$ identity matrix.

B.2.3A MIMO Channel Correlation Matrices using cross polarized antennas

The MIMO channel correlation matrices defined in B.2.3A apply for the antenna configuration using cross polarized antennas at both eNodeB and UE. The cross-polarized antenna elements with +/-45 degrees polarization slant angles are deployed at eNB and cross-polarized antenna elements with +90/0 degrees polarization slant angles are deployed at UE.

For the cross-polarized antennas, the N antennas are labelled such that antennas for one polarization are listed from 1 to N/2 and antennas for the other polarization are listed from N/2+1 to N, where N is the number of transmit or receive antennas.

B.2.3A.1 Definition of MIMO Correlation Matrices using cross polarized antennas

For the channel spatial correlation matrix, the following is used:

$$R_{spat} = P(R_{eNB} \otimes \Gamma \otimes R_{UE})P^T$$

Where

- R_{UE} is the spatial correlation matrix at the UE with same polarization,
- R_{eNB} is the spatial correlation matrix at the eNB with same polarization,
- Γ is a polarization correlation matrix, and
- $(\bullet)^T$ denotes transpose.

The matrix Γ is defined as

$$\Gamma = \begin{bmatrix} 1 & 0 & -\gamma & 0 \\ 0 & 1 & 0 & \gamma \\ -\gamma & 0 & 1 & 0 \\ 0 & \gamma & 0 & 1 \end{bmatrix}$$

A permutation matrix P elements are defined as

$$P(a,b) = \begin{cases} 1 & \text{for } a = (j-1)Nr + i \text{ and } b = 2(j-1)Nr + i, \quad i = 1, \dots, Nr, j = 1, \dots, Nt/2 \\ 1 & \text{for } a = (j-1)Nr + i \text{ and } b = 2(j - Nt/2)Nr - Nr + i, \quad i = 1, \dots, Nr, j = Nt/2 + 1, \dots, Nt \\ 0 & \text{otherwise} \end{cases}$$

where N_t and N_r is the number of transmitter and receiver respectively. This is used to map the spatial correlation coefficients in accordance with the antenna element labelling system described in B.2.3A.

B.2.3A.2 Spatial Correlation Matrices using cross polarized antennas at eNB and UE sides

B.2.3A.2.1 Spatial Correlation Matrices at eNB side

For 2-antenna transmitter using one pair of cross-polarized antenna elements, $R_{eNB} = 1$.

For 4-antenna transmitter using two pairs of cross-polarized antenna elements, $R_{eNB} = \begin{pmatrix} 1 & \alpha \\ \alpha^* & 1 \end{pmatrix}$.

For 8-antenna transmitter using four pairs of cross-polarized antenna elements, $R_{eNB} = \begin{pmatrix} 1 & \alpha^{1/9} & \alpha^{4/9} & \alpha \\ \alpha^{1/9*} & 1 & \alpha^{1/9} & \alpha^{4/9} \\ \alpha^{4/9*} & \alpha^{1/9*} & 1 & \alpha^{1/9} \\ \alpha^* & \alpha^{4/9*} & \alpha^{1/9*} & 1 \end{pmatrix}$.

B.2.3A.2.2 Spatial Correlation Matrices at UE side

For 2-antenna receiver using one pair of cross-polarized antenna elements, $R_{UE} = 1$.

For 4-antenna receiver using two pairs of cross-polarized antenna elements, $R_{UE} = \begin{pmatrix} 1 & \beta \\ \beta^* & 1 \end{pmatrix}$.

B.2.3A.3 MIMO Correlation Matrices using cross polarized antennas

The values for parameters α , β and γ for high spatial correlation are given in Table B.2.3A.3-1.

Table B.2.3A.3-1

High spatial correlation		
α	β	γ
0.9	0.9	0.3
Note 1: Value of α applies when more than one pair of cross-polarized antenna elements at eNB side.		
Note 2: Value of β applies when more than one pair of cross-polarized antenna elements at UE side.		

The correlation matrices for high spatial correlation are defined in Table B.2.3A.3-2 as below.

The values in Table B.2.3A.3-2 have been adjusted to insure the correlation matrix is positive semi-definite after round-off to 4 digit precision. This is done using the equation:

$$\mathbf{R}_{high} = [\mathbf{R}_{spat} + a\mathbf{I}_n] / (1 + a)$$

Where the value “a” is a scaling factor such that the smallest value is used to obtain a positive semi-definite result. For the 8x2 high spatial correlation case, a=0.00010.

Table B.2.3A.3-2: MIMO correlation matrices for high spatial correlation

8x2 case	$R_{high} =$	1.0000 0.0000 0.9883 0.0000 0.9542 0.0000 0.8999 0.0000 -0.3000 0.0000 -0.2965 0.0000 -0.2862 0.0000 -0.2700 0.0000
		0.0000 1.0000 0.0000 0.9883 0.0000 0.9542 0.0000 0.8999 0.0000 0.3000 0.0000 0.2965 0.0000 0.2862 0.0000 0.2700
		0.9883 0.0000 1.0000 0.0000 0.9883 0.0000 0.9542 0.0000 -0.2965 0.0000 -0.3000 0.0000 -0.2965 0.0000 -0.2862 0.0000
		0.0000 0.9883 0.0000 1.0000 0.0000 0.9883 0.0000 0.9542 0.0000 0.2965 0.0000 0.3000 0.0000 0.2965 0.0000 0.2862
		0.9542 0.0000 0.9883 0.0000 1.0000 0.0000 0.9883 0.0000 -0.2862 0.0000 -0.2965 0.0000 -0.3000 0.0000 -0.2965 0.0000
		0.0000 0.9542 0.0000 0.9883 0.0000 1.0000 0.0000 0.9883 0.0000 0.2862 0.0000 0.2965 0.0000 0.3000 0.0000 0.2965
		0.8999 0.0000 0.9542 0.0000 0.9883 0.0000 1.0000 0.0000 -0.2700 0.0000 -0.2862 0.0000 -0.2965 0.0000 -0.3000 0.0000
		0.0000 0.8999 0.0000 0.9542 0.0000 0.9883 0.0000 1.0000 0.0000 0.2700 0.0000 0.2862 0.0000 0.2965 0.0000 0.3000
		-0.3000 0.0000 -0.2965 0.0000 -0.2862 0.0000 -0.2700 0.0000 1.0000 0.0000 0.9883 0.0000 0.9542 0.0000 0.8999 0.0000
		0.0000 0.3000 0.0000 0.2965 0.0000 0.2862 0.0000 0.2700 0.0000 1.0000 0.0000 0.9883 0.0000 0.9542 0.0000 0.8999
		-0.2965 0.0000 -0.3000 0.0000 -0.2965 0.0000 -0.2862 0.0000 0.9883 0.0000 1.0000 0.0000 0.9883 0.0000 0.9542 0.0000
		0.0000 0.2965 0.0000 0.3000 0.0000 0.2965 0.0000 0.2862 0.0000 0.9883 0.0000 1.0000 0.0000 0.9883 0.0000 0.9542
		-0.2862 0.0000 -0.2965 0.0000 -0.3000 0.0000 -0.2965 0.0000 0.9542 0.0000 0.9883 0.0000 1.0000 0.0000 0.9883 0.0000
		0.0000 0.2862 0.0000 0.2965 0.0000 0.3000 0.0000 0.2965 0.0000 0.9542 0.0000 0.9883 0.0000 1.0000 0.0000 0.9883
		-0.2700 0.0000 -0.2862 0.0000 -0.2965 0.0000 -0.3000 0.0000 0.8999 0.0000 0.9542 0.0000 0.9883 0.0000 1.0000 0.0000
		0.0000 0.2700 0.0000 0.2862 0.0000 0.2965 0.0000 0.3000 0.0000 0.8999 0.0000 0.9542 0.0000 0.9883 0.0000 1.0000

B.2.3A.4 Beam steering approach

Given the channel spatial correlation matrix in B.2.3A.1, the corresponding random channel matrix \mathbf{H} can be calculated. The signal model for the k-th subframe is denoted as

$$y = \mathbf{H}D_{\theta_k} Wx + n$$

Where

- \mathbf{H} is the $N_r \times N_t$ channel matrix per subcarrier.

- D_{θ_k} is the steering matrix, which is $D_{\theta_k} = \begin{bmatrix} 1 & 0 \\ 0 & 1 \end{bmatrix} \otimes \begin{bmatrix} 1 & 0 & 0 & 0 \\ 0 & e^{j\theta_k} & 0 & 0 \\ 0 & 0 & e^{j2\theta_k} & 0 \\ 0 & 0 & 0 & e^{j3\theta_k} \end{bmatrix}$,

- θ_k controls the phase variation, and the phase for k-th subframe is denoted by $\theta_k = \theta_0 + \Delta\theta \cdot k$, where θ_0 is the random start value with the uniform distribution, i.e., $\theta_0 \in [0, 2\pi]$, $\Delta\theta$ is the step of phase variation, which is defined in Table B.2.3A.4-1, and k is the linear increment of 1 for every subframe throughout the simulation,
- W is the precoding matrix for 8 transmission antennas,
- y is the received signal, x is the transmitted signal, and n is AWGN.

Table B.2.3A.4-1: The step of phase variation

Variation Step	Value (rad/subframe)
$\Delta\theta$	1.2566×10^{-3}

B.2.4 Propagation conditions for CQI tests

For Channel Quality Indication (CQI) tests, the following additional multi-path profile is used:

$$h(t, \tau) = \delta(\tau) + a \exp(-i2\pi f_D t) \delta(\tau - \tau_d),$$

in continuous time (t, τ) representation, with τ_d the delay, a a constant and f_D the Doppler frequency. The same $h(t, \tau)$ is used to describe the fading channel between every pair of Tx and Rx.

B.2.5 Void

B.2.6 MBSFN Propagation Channel Profile

Table B.2.6-1 shows propagation conditions that are used for the MBSFN performance requirements in multi-path fading environment in an extended delay spread environment.

Table B.2.6-1: Propagation Conditions for Multi-Path Fading Environments for MBSFN Performance Requirements in an extended delay spread environment

Extended Delay Spread	
Maximum Doppler frequency [5Hz]	
Relative Delay [ns]	Relative Mean Power [dB]
0	0
30	-1.5
150	-1.4
310	-3.6
370	-0.6
1090	-7.0
12490	-10
12520	-11.5
12640	-11.4
12800	-13.6
12860	-10.6
13580	-17.0
27490	-20
27520	-21.5
27640	-21.4
27800	-23.6
27860	-20.6
28580	-27.0

B.3 High speed train scenario

The high speed train condition for the test of the baseband performance is a non fading propagation channel with one tap. Doppler shift is given by

$$f_s(t) = f_d \cos \theta(t) \quad (\text{B.3.1})$$

where $f_s(t)$ is the Doppler shift and f_d is the maximum Doppler frequency. The cosine of angle $\theta(t)$ is given by

$$\cos \theta(t) = \frac{D_s/2 - vt}{\sqrt{D_{\min}^2 + (D_s/2 - vt)^2}}, \quad 0 \leq t \leq D_s/v \quad (\text{B.3.2})$$

$$\cos \theta(t) = \frac{-1.5D_s + vt}{\sqrt{D_{\min}^2 + (-1.5D_s + vt)^2}}, \quad D_s/v < t \leq 2D_s/v \quad (\text{B.3.3})$$

$$\cos \theta(t) = \cos \theta(t \bmod (2D_s/v)), \quad t > 2D_s/v \quad (\text{B.3.4})$$

where $D_s/2$ is the initial distance of the train from eNodeB, and D_{\min} is eNodeB Railway track distance, both in meters; v is the velocity of the train in m/s, t is time in seconds.

Doppler shift and cosine angle are given by equation B.3.1 and B.3.2-B.3.4 respectively, where the required input parameters listed in table B.3-1 and the resulting Doppler shift shown in Figure B.3-1 are applied for all frequency bands.

Table B.3-1: High speed train scenario

Parameter	Value
D_s	300 m
D_{\min}	2 m
v	300 km/h
f_d	750 Hz

NOTE 1: Parameters for HST conditions in table B.3-1 including f_d and Doppler shift trajectories presented on figure B.3-1 were derived for Band 7.

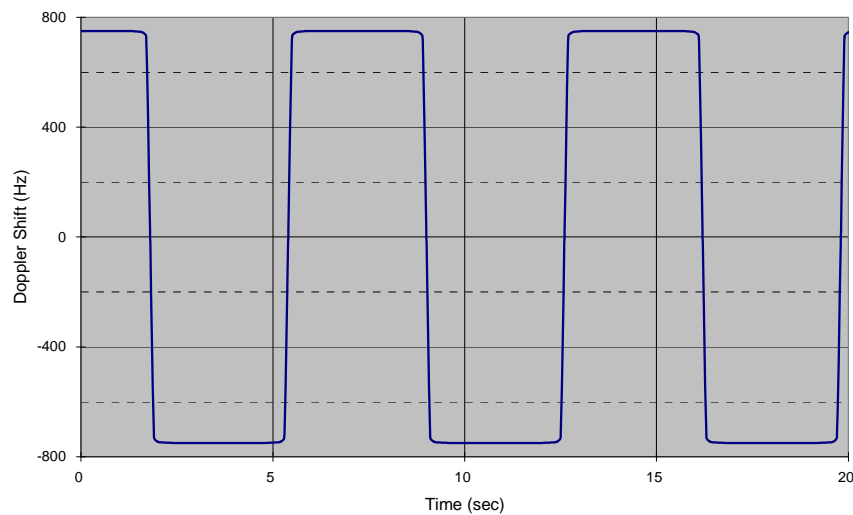

Figure B.3-1: Doppler shift trajectory

For 1x2 antenna configuration, the same $h(t,\tau)$ is used to describe the channel between every pair of Tx and Rx.

For 2x2 antenna configuration, the same $h(t,\tau)$ is used to describe the channel between every pair of Tx and Rx with

phase shift according to $\mathbf{H} = \begin{pmatrix} 1 & j \\ 1 & -j \end{pmatrix}$.

B.4 Beamforming Model

B.4.1 Single-layer random beamforming (Antenna port 5, 7, or 8)

Single-layer transmission on antenna port 5 or on antenna port 7 or 8 without a simultaneous transmission on the other antenna port, is defined by using a precoder vector $W(i)$ of size 2×1 randomly selected with the number of layers

$\nu = 1$ from Table 6.3.4.2.3-1 in [4] as beamforming weights. This precoder takes as an input the signal $y^{(p)}(i)$,

$i = 0, 1, \dots, M_{\text{symp}}^{\text{ap}} - 1$, for antenna port $p \in \{5, 7, 8\}$, with $M_{\text{symp}}^{\text{ap}}$ the number of modulation symbols including the

user-specific reference symbols (DRS), and generates a block of signals $y_{\text{bf}}(i) = [y_{\text{bf}}(i) \quad \tilde{y}_{\text{bf}}(i)]^T$ the elements of which are to be mapped onto the same physical RE but transmitted on different antenna elements:

$$\begin{bmatrix} y_{bf}(i) \\ \tilde{y}_{bf}(i) \end{bmatrix} = W(i)y^{(p)}(i)$$

Single-layer transmission on antenna port 7 or 8 with a simultaneous transmission on the other antenna port, is defined by using a pair of precoder vectors $W_1(i)$ and $W_2(i)$ each of size 2×1 , which are not identical and randomly selected with the number of layers $\nu = 1$ from Table 6.3.4.2.3-1 in [4], as beamforming weights, and normalizing the transmit power as follows:

$$\begin{bmatrix} y_{bf}(i) \\ \tilde{y}_{bf}(i) \end{bmatrix} = \frac{1}{\sqrt{2}} (W_1(i)y^{(7)}(i) + W_2(i)y^{(8)}(i))$$

The precoder update granularity is specific to a test case.

The CSI reference symbols $a_{k,l}^{(p)}$ satisfying $p \bmod 2 = 1$, $p \in \{15,16,\dots,22\}$, are transmitted on the same physical antenna element as the modulation symbols $y_{bf}(i)$. The CSI reference symbols $a_{k,l}^{(p)}$ satisfying $p \bmod 2 = 0$, $p \in \{15,16,\dots,22\}$, are transmitted on the same physical antenna element as the modulation symbols $\tilde{y}_{bf}(i)$.

B.4.2 Dual-layer random beamforming (antenna ports 7 and 8)

Dual-layer transmission on antenna ports 7 and 8 is defined by using a precoder matrix $W(i)$ of size 2×2 randomly selected with the number of layers $\nu = 2$ from Table 6.3.4.2.3-1 in [4] as beamforming weights. This precoder takes as an input a block of signals for antenna ports 7 and 8, $y(i) = [y^{(7)}(i) \quad y^{(8)}(i)]^T$, $i = 0,1,\dots,M_{\text{symb}}^{\text{ap}} - 1$, with $M_{\text{symb}}^{\text{ap}}$ being the number of modulation symbols per antenna port including the user-specific reference symbols, and generates a block of signals $y_{bf}(i) = [y_{bf}(i) \quad \tilde{y}_{bf}(i)]^T$ the elements of which are to be mapped onto the same physical RE but transmitted on different antenna elements:

$$\begin{bmatrix} y_{bf}(i) \\ \tilde{y}_{bf}(i) \end{bmatrix} = W(i) \begin{bmatrix} y^{(7)}(i) \\ y^{(8)}(i) \end{bmatrix},$$

The precoder update granularity is specific to a test case.

The CSI reference symbols $a_{k,l}^{(p)}$ satisfying $p \bmod 2 = 1$, $p \in \{15,16,\dots,22\}$, are transmitted on the same physical antenna element as the modulation symbols $y_{bf}(i)$. The CSI reference symbols $a_{k,l}^{(p)}$ satisfying $p \bmod 2 = 0$, $p \in \{15,16,\dots,22\}$, are transmitted on the same physical antenna element as the modulation symbols $\tilde{y}_{bf}(i)$.

B.4.3 Generic beamforming model (antenna ports 7-14)

The transmission on antenna port(s) $p = 7,8,\dots,\nu + 6$ is defined by using a precoder matrix $W(i)$ of size $N_{\text{CSI}} \times \nu$, where N_{CSI} is the number of CSI reference signals configured per test and ν is the number of spatial layers. This precoder takes as an input a block of signals for antenna port(s) $p = 7,8,\dots,\nu + 6$,

$y^{(p)}(i) = [y^{(7)}(i) \quad y^{(8)}(i) \quad \dots \quad y^{(6+\nu)}(i)]$, $i = 0,1,\dots,M_{\text{symb}}^{\text{ap}} - 1$, with $M_{\text{symb}}^{\text{ap}}$ being the number of modulation symbols per antenna port including the user-specific reference symbols (DM-RS), and generates a block of signals $y_{bf}^{(q)}(i) = [y_{bf}^{(0)}(i) \quad y_{bf}^{(1)}(i) \quad \dots \quad y_{bf}^{(N_{\text{CSI}}-1)}(i)]^T$ the elements of which are to be mapped onto the same time-frequency index pair (k,l) but transmitted on different physical antenna elements:

$$\begin{bmatrix} y_{bf}^{(0)}(i) \\ y_{bf}^{(1)}(i) \\ \vdots \\ y_{bf}^{(N_{CSI}-1)}(i) \end{bmatrix} = W(i) \begin{bmatrix} y^{(7)}(i) \\ y^{(8)}(i) \\ \vdots \\ y^{(6+v)}(i) \end{bmatrix}$$

The precoder matrix $W(i)$ is specific to a test case.

The physical antenna elements are identified by indices $j = 0, 1, \dots, N_{ANT} - 1$, where $N_{ANT} = N_{CSI}$ is the number of physical antenna elements configured per test.

Modulation symbols $y_{bf}^{(q)}(i)$ with $q \in \{0, 1, \dots, N_{CSI} - 1\}$ (i.e. beamformed PDSCH and DM-RS) are mapped to the physical antenna index $j = q$.

Modulation symbols $y^{(p)}(i)$ with $p \in \{0, 1, \dots, P - 1\}$ (i.e. PBCH, PDCCH, PHICH, PCFICH) are mapped to the physical antenna index $j = p$, where P is the number of cell-specific reference signals configured per test.

Modulation symbols $a_{k,l}^{(p)}$ with $p \in \{0, 1, \dots, P - 1\}$ (i.e. CRS) are mapped to the physical antenna index $j = p$, where P is the number of cell-specific reference signals configured per test.

Modulation symbols $a_{k,l}^{(p)}$ with $p \in \{15, 16, \dots, 14 + N_{CSI}\}$ (i.e. CSI-RS) are mapped to the physical antenna index $j = p - 15$, where N_{CSI} is the number of CSI reference signals configured per test.

Annex C (normative): Downlink Physical Channels

C.1 General

This annex specifies the downlink physical channels that are needed for setting a connection and channels that are needed during a connection.

C.2 Set-up

Table C.2-1 describes the downlink Physical Channels that are required for connection set up.

Table C.2-1: Downlink Physical Channels required for connection set-up

Physical Channel
PBCH
SSS
PSS
PCFICH
PDCCH
PHICH
PDSCH

C.3 Connection

The following clauses, describes the downlink Physical Channels that are transmitted during a connection i.e., when measurements are done.

C.3.1 Measurement of Receiver Characteristics

Table C.3.1-1 is applicable for measurements on the Receiver Characteristics (clause 7).

Table C.3.1-1: Downlink Physical Channels transmitted during a connection (FDD and TDD)

Physical Channel	EPRE Ratio	
PBCH	PBCH_RA = 0 dB	
	PBCH_RB = 0 dB	
PSS	PSS_RA = 0 dB	
SSS	SSS_RA = 0 dB	
PCFICH	PCFICH_RB = 0 dB	
PDCCH	PDCCH_RA = 0 dB	
	PDCCH_RB = 0 dB	
PDSCH	PDSCH_RA = 0 dB	
	PDSCH_RB = 0 dB	
OCNG	OCNG_RA = 0 dB	
	OCNG_RB = 0 dB	

NOTE 1: No boosting is applied.

Table C.3.1-2: Power allocation for OFDM symbols and reference signals

Parameter	Unit	Value	Note
Transmitted power spectral density I_{or}	dBm/15 kHz	Test specific	1. I_{or} shall be kept constant throughout all OFDM symbols
Cell-specific reference signal power ratio E_{RS} / I_{or}		0 dB	

C.3.2 Measurement of Performance requirements

Table C.3.2-1 is applicable for measurements in which uniform RS-to-EPRE boosting for all downlink physical channels.

Table C.3.2-1: Downlink Physical Channels transmitted during a connection (FDD and TDD)

Physical Channel	EPRE Ratio	
PBCH	PBCH_RA = $\rho_A + \sigma$	
	PBCH_RB = $\rho_B + \sigma$	
PSS	PSS_RA = 0 (Note 3)	
SSS	SSS_RA = 0 (Note 3)	
PCFICH	PCFICH_RB = $\rho_B + \sigma$	
PDCCH	PDCCH_RA = $\rho_A + \sigma$	
	PDCCH_RB = $\rho_B + \sigma$	
PDSCH	PDSCH_RA = ρ_A	
	PDSCH_RB = ρ_B	
PMCH	PMCH_RA = ρ_A	
	PMCH_RB = ρ_B	
MBSFN RS	MBSFN_RS_RA = ρ_A	
	MBSFN_RS_RB = ρ_B	
OCNG	OCNG_RA = $\rho_A + \sigma$	
	OCNG_RB = $\rho_B + \sigma$	

NOTE 1: $\rho_A = \rho_B = 0$ dB means no RS boosting.

NOTE 2: MBSFN RS and OCNG are not defined downlink physical channels in [4].

NOTE 3: Assuming PSS and SSS transmitted on a single antenna port.

NOTE 4: ρ_A , ρ_B and σ are test specific.

NOTE 5: For TM 8 and TM 9 ρ_A , ρ_B are used for the purpose of the test set up only.

Table C.3.2-2: Power allocation for OFDM symbols and reference signals

Parameter	Unit	Value	Note
Total transmitted power spectral density I_{or}	dBm/15 kHz	Test specific	1. I_{or} shall be kept constant throughout all OFDM symbols
Cell-specific reference signal power ratio E_{RS} / I_{or}		Test specific	1. Applies for antenna port p
Energy per resource element EPRE		Test specific	1. The complex-valued symbols $y^{(p)}(i)$ and $a_{k,l}^{(p)}$ defined in [4] shall conform to the given EPRE value. 2. For TM8 and TM9 the reference point for EPRE is before the precoder in Annex B.4.

C.3.3 Aggressor cell power allocation for Measurement of Performance Requirements when ABS is Configured

For the performance requirements and channel state information reporting when ABS is configured, the power allocation for the physical channels of the aggressor cell in non-ABS and ABS is listed in Table C.3.3-1.

Table C.3.3-1: Downlink physical channels transmitted in aggressor cell when ABS is configured in this cell

Physical Channel	Parameters	Unit	EPRE Ratio	
			Non-ABS	ABS
PBCH	PBCH_RA	dB	ρ_A	Note 1
	PBCH_RB	dB	ρ_B	Note 1
PSS	PSS_RA	dB	ρ_A	Note 1
SSS	SSS_RA	dB	ρ_A	Note 1
PCFICH	PCFICH_RB	dB	ρ_B	Note 1
PHICH	PHICH_RA	dB	ρ_A	Note 1
	PHICH_RB	dB	ρ_B	Note 1
PDCCH	PDCCH_RA	dB	ρ_A	Note 1
	PDCCH_RB	dB	ρ_B	Note 1
PDSCH	PDSCH_RA	dB	N/A	Note 1
	PDSCH_RB	dB	N/A	Note 1
OCNG	OCNG_RA	dB	ρ_A	Note 1
	OCNG_RB	dB	ρ_B	Note 1

Note 1: $-\infty$ dB is allocated for this channel in this test.

Annex D (normative): Characteristics of the interfering signal

D.1 General

When the channel band width is wider or equal to 5MHz, a modulated 5MHz full band width E-UTRA down link signal and CW signal are used as interfering signals when RF performance requirements for E-UTRA UE receiver are defined. For channel band widths below 5MHz, the band width of modulated interferer should be equal to band width of the received signal.

D.2 Interference signals

Table D.2-1 describes the modulated interferer for different channel band width options.

Table D.2-1: Description of modulated E-UTRA interferer

	Channel bandwidth					
	1.4 MHz	3 MHz	5 MHz	10 MHz	15 MHz	20 MHz
$BW_{\text{Interferer}}$	1.4 MHz	3 MHz	5 MHz	5 MHz	5 MHz	5 MHz
RB	6	15	25	25	25	25

Annex E (normative): Environmental conditions

E.1 General

This normative annex specifies the environmental requirements of the UE. Within these limits the requirements of the present documents shall be fulfilled.

E.2 Environmental

The requirements in this clause apply to all types of UE(s).

E.2.1 Temperature

The UE shall fulfil all the requirements in the full temperature range of:

Table E.2.1-1

+15 °C to +35 °C	for normal conditions (with relative humidity of 25 % to 75 %)
-10 °C to +55 °C	for extreme conditions (see IEC publications 68-2-1 and 68-2-2)

Outside this temperature range the UE, if powered on, shall not make ineffective use of the radio frequency spectrum. In no case shall the UE exceed the transmitted levels as defined in clause 6.2 for extreme operation.

E.2.2 Voltage

The UE shall fulfil all the requirements in the full voltage range, i.e. the voltage range between the extreme voltages.

The manufacturer shall declare the lower and higher extreme voltages and the approximate shutdown voltage. For the equipment that can be operated from one or more of the power sources listed below, the lower extreme voltage shall not be higher, and the higher extreme voltage shall not be lower than that specified below.

Table E.2.2-1

Power source	Lower extreme voltage	Higher extreme voltage	Normal conditions voltage
AC mains	0,9 * nominal	1,1 * nominal	nominal
Regulated lead acid battery	0,9 * nominal	1,3 * nominal	1,1 * nominal
Non regulated batteries:			
Leclanché	0,85 * nominal	Nominal	Nominal
Lithium	0,95 * nominal	1,1 * Nominal	1,1 * Nominal
Mercury/nickel & cadmium	0,90 * nominal		Nominal

Outside this voltage range the UE if powered on, shall not make ineffective use of the radio frequency spectrum. In no case shall the UE exceed the transmitted levels as defined in clause 6.2 for extreme operation. In particular, the UE shall inhibit all RF transmissions when the power supply voltage is below the manufacturer declared shutdown voltage.

E.2.3 Vibration

The UE shall fulfil all the requirements when vibrated at the following frequency/amplitudes.

Table E.2.3-1

Frequency	ASD (Acceleration Spectral Density) random vibration
5 Hz to 20 Hz	0,96 m ² /s ³
20 Hz to 500 Hz	0,96 m ² /s ³ at 20 Hz, thereafter -3 dB/Octave

Outside the specified frequency range the UE, if powered on, shall not make ineffective use of the radio frequency spectrum. In no case shall the UE exceed the transmitted levels as defined in TS 36.101 for extreme operation.

Annex F (normative): Transmit modulation

Note: this annex applies for single carrier and in case of carrier aggregation for the component carrier, with PRBs allocated.

F.1 Measurement Point

Figure F.1-1 shows the measurement point for the unwanted emission falling into non-allocated RB(s) and the EVM for the allocated RB(s).

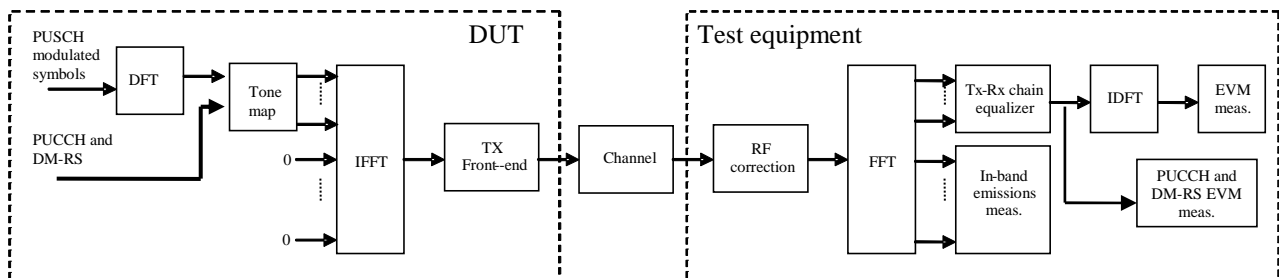

Figure F.1-1: EVM measurement points

F.2 Basic Error Vector Magnitude measurement

The EVM is the difference between the ideal waveform and the measured waveform for the allocated RB(s)

$$EVM = \sqrt{\frac{\sum_{v \in T_m} |z'(v) - i(v)|^2}{|T_m| \cdot P_0}},$$

where

T_m is a set of $|T_m|$ modulation symbols with the considered modulation scheme being active within the measurement period,

$z'(v)$ are the samples of the signal evaluated for the EVM,

$i(v)$ is the ideal signal reconstructed by the measurement equipment, and

P_0 is the average power of the ideal signal. For normalized modulation symbols P_0 is equal to 1.

The basic EVM measurement interval is defined over one slot in the time domain for PUCCH and PUSCH and over one preamble sequence for the PRACH.

F.3 Basic in-band emissions measurement

The in-band emissions are a measure of the interference falling into the non-allocated resources blocks. The in-band emission requirement is evaluated for PUCCH and PUSCH transmissions. The in-band emission requirement is not evaluated for PRACH transmissions.

The in-band emissions are measured as follows

$$Emissions_{absolute}(\Delta_{RB}) = \begin{cases} \frac{1}{|T_s|} \sum_{t \in T_s} \sum_{f_l + (12 \cdot \Delta_{RB} + 11) \cdot \Delta f}^{\max(f_{\min}, f_l + 12 \cdot \Delta_{RB} \cdot \Delta f)} |Y(t, f)|^2, \Delta_{RB} < 0 \\ \frac{1}{|T_s|} \sum_{t \in T_s} \sum_{f_h + (12 \cdot \Delta_{RB} - 11) \cdot \Delta f}^{\min(f_{\max}, f_h + 12 \cdot \Delta_{RB} \cdot \Delta f)} |Y(t, f)|^2, \Delta_{RB} > 0 \end{cases},$$

where

T_s is a set of $|T_s|$ SC-FDMA symbols with the considered modulation scheme being active within the measurement period,

Δ_{RB} is the starting frequency offset between the allocated RB and the measured non-allocated RB (e.g. $\Delta_{RB} = 1$ or $\Delta_{RB} = -1$ for the first adjacent RB),

f_{\min} (resp. f_{\max}) is the lower (resp. upper) edge of the UL system BW,

f_l and f_h are the lower and upper edge of the allocated BW, and

$Y(t, f)$ is the frequency domain signal evaluated for in-band emissions as defined in the subsection (ii)

The relative in-band emissions are, given by

$$Emissions_{relative}(\Delta_{RB}) = \frac{Emissions_{absolute}(\Delta_{RB})}{\frac{1}{|T_s| \cdot N_{RB}} \sum_{t \in T_s} \sum_{f_l}^{f_l + (12 \cdot N_{RB} - 1) \Delta f} |Y(t, f)|^2}$$

where

N_{RB} is the number of allocated RBs

The basic in-band emissions measurement interval is defined over one slot in the time domain. When the PUSCH or PUCCH transmission slot is shortened due to multiplexing with SRS, the in-band emissions measurement interval is reduced by one SC-FDMA symbol, accordingly.

In the evaluation of in-band emissions, the timing is set according to $\Delta \tilde{t} = \Delta \tilde{c}$, where sample time offsets $\Delta \tilde{t}$ and $\Delta \tilde{c}$ are defined in subclause F.4.

F.4 Modified signal under test

Implicit in the definition of EVM is an assumption that the receiver is able to compensate a number of transmitter impairments.

The PUSCH data or PRACH signal under test is modified and, in the case of PUSCH data signal, decoded according to::

$$Z'(t, f) = IDFT \left\{ \frac{FFT \left\{ z(v - \Delta\tilde{t}) \cdot e^{-j2\pi\Delta\tilde{f}v} \right\} e^{j2\pi\Delta\tilde{t}f}}{\tilde{a}(t, f) \cdot e^{j\tilde{\varphi}(t, f)}} \right\}$$

where

$z(v)$ is the time domain samples of the signal under test.

The PUCCH or PUSCH demodulation reference signal or PUCCH data signal under test is equalised and, in the case of PUCCH data signal decoded according to:

$$Z'(t, f) = \frac{FFT \left\{ z(v - \Delta\tilde{t}) \cdot e^{-j2\pi\Delta\tilde{f}v} \right\} e^{j2\pi\Delta\tilde{t}f}}{\tilde{a}(t, f) \cdot e^{j\tilde{\varphi}(t, f)}}$$

where

$z(v)$ is the time domain samples of the signal under test.

To minimize the error, the signal under test should be modified with respect to a set of parameters following the procedure explained below.

Notation:

$\Delta\tilde{t}$ is the sample timing difference between the FFT processing window in relation to nominal timing of the ideal signal.

$\Delta\tilde{f}$ is the RF frequency offset.

$\tilde{\varphi}(t, f)$ is the phase response of the TX chain.

$\tilde{a}(t, f)$ is the amplitude response of the TX chain.

In the following $\Delta\tilde{c}$ represents the middle sample of the EVM window of length W (defined in the next subsections) or the last sample of the first window half if W is even.

The EVM analyser shall

- detect the start of each slot and estimate $\Delta\tilde{t}$ and $\Delta\tilde{f}$,
- determine $\Delta\tilde{c}$ so that the EVM window of length W is centred
 - on the time interval determined by the measured cyclic prefix minus 16 samples of the considered OFDM symbol for symbol 0 for normal CP, i.e. the first 16 samples of the CP should not be taken into account for this step. In the determination of the number of excluded samples, a sampling rate of 30.72MHz was assumed. If a different sampling rate is used, the number of excluded samples is scaled linearly.
 - on the measured cyclic prefix of the considered OFDM symbol symbol for symbol 1 to 6 for normal CP and for symbol 0 to 5 for extended CP.
 - on the measured preamble cyclic prefix for the PRACH

To determine the other parameters a sample timing offset equal to $\Delta\tilde{c}$ is corrected from the signal under test. The EVM analyser shall then

- correct the RF frequency offset $\Delta\tilde{f}$ for each time slot, and

➤ apply an FFT of appropriate size. The chosen FFT size shall ensure that in the case of an ideal signal under test, there is no measured inter-subcarrier interference.

The carrier leakage shall be removed from the evaluated signal before calculating the EVM and the in-band emissions; however, the removed relative carrier leakage power also has to satisfy the applicable requirement.

At this stage the allocated RBs shall be separated from the non-allocated RBs. In the case of PUCCH and PUSCH EVM, the signal on the non-allocated RB(s), $Y(t, f)$, is used to evaluate the in-band emissions.

Moreover, the following procedure applies only to the signal on the allocated RB(s).

- In the case of PUCCH and PUSCH, the UL EVM analyzer shall estimate the TX chain equalizer coefficients $\tilde{a}(t, f)$ and $\tilde{\varphi}(t, f)$ used by the ZF equalizer for all subcarriers by time averaging at each signal subcarrier of the amplitude and phase of the reference and data symbols. The time-averaging length is 1 slot. This process creates an average amplitude and phase for each signal subcarrier used by the ZF equalizer. The knowledge of data modulation symbols may be required in this step because the determination of symbols by demodulation is not reliable before signal equalization.
- In the case of PRACH, the UL EVM analyzer shall estimate the TX chain coefficients $\tilde{a}(t)$ and $\tilde{\varphi}(t)$ used for phase and amplitude correction and are selected so as to minimize the resulting EVM. The TX chain coefficients are not dependent on frequency, i.e. $\tilde{a}(t, f) = \tilde{a}(t)$ and $\tilde{\varphi}(t, f) = \tilde{\varphi}(t)$. The TX chain coefficient are chosen independently for each preamble transmission and for each $\Delta\tilde{t}$.

At this stage estimates of $\Delta\tilde{f}$, $\tilde{a}(t, f)$, $\tilde{\varphi}(t, f)$ and $\Delta\tilde{c}$ are available. $\Delta\tilde{t}$ is one of the extremities of the window W , i.e. $\Delta\tilde{t}$ can be $\Delta\tilde{c} + \alpha - \left\lfloor \frac{W}{2} \right\rfloor$ or $\Delta\tilde{c} + \left\lfloor \frac{W}{2} \right\rfloor$, where $\alpha = 0$ if W is odd and $\alpha = 1$ if W is even. The EVM analyser shall then

- calculate EVM_l with $\Delta\tilde{t}$ set to $\Delta\tilde{c} + \alpha - \left\lfloor \frac{W}{2} \right\rfloor$,
- calculate EVM_h with $\Delta\tilde{t}$ set to $\Delta\tilde{c} + \left\lfloor \frac{W}{2} \right\rfloor$.

F.5 Window length

F.5.1 Timing offset

As a result of using a cyclic prefix, there is a range of $\Delta\tilde{t}$, which, at least in the case of perfect Tx signal quality, would give close to minimum error vector magnitude. As a first order approximation, that range should be equal to the length of the cyclic prefix. Any time domain windowing or FIR pulse shaping applied by the transmitter reduces the $\Delta\tilde{t}$ range within which the error vector is close to its minimum.

F.5.2 Window length

The window length W affects the measured EVM, and is expressed as a function of the configured cyclic prefix length. In the case where equalization is present, as with frequency domain EVM computation, the effect of FIR is reduced. This is because the equalization can correct most of the linear distortion introduced by the FIR. However, the time domain windowing effect can't be removed.

F.5.3 Window length for normal CP

The table below specifies the EVM window length at channel bandwidths 1.4, 3, 5, 10, 15, 20 MHz, for normal CP. The nominal window length for 3 MHz is rounded down one sample to allow the window to be centered on the symbol.

Table F.5.3-1 EVM window length for normal CP

Channel Bandwidth MHz	Cyclic prefix length ¹ N_{cp} for symbol 0	Cyclic prefix length ¹ N_{cp} for symbols 1 to 6	Nominal FFT size	Cyclic prefix for symbols 1 to 6 in FFT samples	EVM window length W in FFT samples	Ratio of W to CP for symbols 1 to 6 ²
1.4	160	144	128	9	5	55.6
3			256	18	12	66.7
5			512	36	32	88.9
10			1024	72	66	91.7
15			1536	108	102	94.4
20			2048	144	136	94.4
Note 1: The unit is number of samples, sampling rate of 30.72MHz is assumed.						
Note 2: These percentages are informative and apply to symbols 1 through 6. Symbol 0 has a longer CP and therefore a lower percentage.						

F.5.4 Window length for Extended CP

The table below specifies the EVM window length at channel bandwidths 1.4, 3, 5, 10, 15, 20 MHz, for extended CP. The nominal window lengths for 3 MHz and 15 MHz are rounded down one sample to allow the window to be centered on the symbol.

Table F.5.4-1 EVM window length for extended CP

Channel Bandwidth MHz	Cyclic prefix length ¹ N_{cp}	Nominal FFT size	Cyclic prefix in FFT samples	EVM window length W in FFT samples	Ratio of W to CP ²
1.4	512	128	32	28	87.5
3		256	64	58	90.6
5		512	128	124	96.9
10		1024	256	250	97.4
15		1536	384	374	97.4
20		2048	512	504	98.4
Note 1: The unit is number of samples, sampling rate of 30.72MHz is assumed.					
Note 2: These percentages are informative					

F.5.5 Window length for PRACH

The table below specifies the EVM window length for PRACH preamble formats 0-4.

Table F.5.5-1 EVM window length for PRACH

Preamble format	Cyclic prefix length ¹ N_{cp}	Nominal FFT size ²	EVM window length W in FFT samples	Ratio of W to CP*
0	3168	24576	3072	96.7%
1	21024	24576	20928	99.5%
2	6240	49152	6144	98.5%
3	21024	49152	20928	99.5%
4	448	4096	432	96.4%
Note 1:	The unit is number of samples, sampling rate of 30.72MHz is assumed			
Note 2:	The use of other FFT sizes is possible as long as appropriate scaling of the window length is applied			
Note 3:	These percentages are informative			

F.6 Averaged EVM

The general EVM is averaged over basic EVM measurements for 20 slots in the time domain.

$$\overline{EVM} = \sqrt{\frac{1}{20} \sum_{i=1}^{20} EVM_i^2}$$

The EVM requirements shall be tested against the maximum of the RMS average at the window W extremities of the EVM measurements:

Thus \overline{EVM}_l is calculated using $\Delta\tilde{t} = \Delta\tilde{t}_l$ in the expressions above and \overline{EVM}_h is calculated using $\Delta\tilde{t} = \Delta\tilde{t}_h$.

Thus we get:

$$EVM = \max(\overline{EVM}_l, \overline{EVM}_h)$$

The calculation of the EVM for the demodulation reference signal, EVM_{DMRS} , follows the same procedure as calculating the general EVM, with the exception that the modulation symbol set T_m defined in clause F.2 is restricted to symbols containing uplink demodulation reference signals.

The basic EVM_{DMRS} measurements are first averaged over 20 slots in the time domain to obtain an intermediate average \overline{EVM}_{DMRS} .

$$\overline{EVM}_{DMRS} = \sqrt{\frac{1}{20} \sum_{i=1}^{20} EVM_{DMRS,i}^2}$$

In the determination of each $EVM_{DMRS,i}$, the timing is set to $\Delta\tilde{t} = \Delta\tilde{t}_l$ if $\overline{EVM}_l > \overline{EVM}_h$, and it is set to $\Delta\tilde{t} = \Delta\tilde{t}_h$ otherwise, where \overline{EVM}_l and \overline{EVM}_h are the general average EVM values calculated in the same 20 slots over which the intermediate average \overline{EVM}_{DMRS} is calculated. Note that in some cases, the general average EVM may be calculated only for the purpose of timing selection for the demodulation reference signal EVM.

Then the results are further averaged to get the EVM for the demodulation reference signal, EVM_{DMRS} ,

$$EVM_{DMRS} = \sqrt{\frac{1}{6} \sum_{j=1}^6 \overline{EVM}_{DMRS,j}^2}$$

The PRACH EVM, EVM_{PRACH} , is averaged over two preamble sequence measurements for preamble formats 0, 1, 2, 3, and it is averaged over 10 preamble sequence measurements for preamble format 4.

The EVM requirements shall be tested against the maximum of the RMS average at the window W extremities of the EVM measurements:

Thus $\overline{EVM}_{PRACH,l}$ is calculated using $\Delta\tilde{t} = \Delta\tilde{t}_l$ and $\overline{EVM}_{PRACH,h}$ is calculated using $\Delta\tilde{t} = \Delta\tilde{t}_h$.

Thus we get:

$$EVM_{PRACH} = \max(\overline{EVM}_{PRACH,l}, \overline{EVM}_{PRACH,h})$$

F.7 Spectrum Flatness

The data shall be taken from FFT coded data symbols and the demodulation reference symbols of the allocated resource block.

Annex G (informative): Reference sensitivity level in lower SNR

This annex contains information on typical receiver sensitivity when HARQ transmission is enabled allowing operation in lower SNR regions (HARQ is disabled in conformance testing), thus representing the configuration normally used in live network operation under noise-limited conditions.

G.1 General

The reference sensitivity power level P_{SENS} with HARQ retransmission enabled (operation in lower SNR) is the minimum mean power applied to both the UE antenna ports at which the residual BLER after HARQ shall meet the requirements for the specified reference measurement channel. The residual BLER after HARQ transmission is defined as follows:

$$BLER_{\text{residual}} = 1 - \frac{A}{B}$$

A : Number of correctly decoded MAC PDUs

B : Number of transmitted MAC PDUs (Retransmitted MAC PDUs are not counted)

G.2 Typical receiver sensitivity performance (QPSK)

The residual BLER after HARQ shall be lower than 1% for the reference measurement channels as specified in Annexes G.3 (with one sided dynamic OCNG Pattern OP.1 FDD/TDD for the DL-signal as described in Annex A.5.1.1/A.5.2.1) with parameters specified in Table G.2-1 and Table G.2-2

Table G.2-1: Reference sensitivity QPSK P_{SENS}

Channel bandwidth							
E-UTRA Band	1.4 MHz (dBm)	3 MHz (dBm)	5 MHz (dBm)	10 MHz (dBm)	15 MHz (dBm)	20 MHz (dBm)	Duplex Mode
1				[-102]			FDD
2				TBD			FDD
3				TBD			FDD
4				TBD			FDD
5				TBD			FDD
6				TBD			FDD
7				TBD			FDD
8				TBD			FDD
9				TBD			FDD
10				TBD			FDD
11				TBD			FDD
12				TBD			FDD
13				TBD			FDD
14				TBD			FDD
...							
17				TBD			FDD
18				TBD			FDD
19				TBD			FDD
20				TBD			FDD
21				TBD			FDD
22				TBD			TBD
23				TBD			FDD
24				[-102]			FDD
...							
33				[-102]			TDD
34				[-102]			TDD
35				[-102]			TDD
36				[-102]			TDD
37				[-102]			TDD
38				[-102]			TDD
39				[-102]			TDD
40				[-102]			TDD
41				[-102]			TDD
42				[-102]			TDD
Note 1:	The transmitter shall be set to P_{UMAX} as defined in clause 6.2.5						
Note 2:	Reference measurement channel is G.3 with one sided dynamic OCNG Pattern OP.1 FDD/TDD as described in Annex A.5.1.1/A.5.2.1						
Note 3:	The signal power is specified per port						
Note 4:	For the UE which supports both Band 3 and Band 9 the reference sensitivity level is FFS.						
Note 5:	For the UE which supports both Band 11 and Band 21 the reference sensitivity level is FFS.						

Table G.2-2 specifies the minimum number of allocated uplink resource blocks for which the reference receive sensitivity requirement in lower SNR must be met.

Table G.2-2: Minimum uplink configuration for reference sensitivity

E-UTRA Band / Channel bandwidth / NRB / Duplex mode							
E-UTRA Band	1.4 MHz	3 MHz	5 MHz	10 MHz	15 MHz	20 MHz	Duplex Mode
1				[6] ¹			FDD
2				[6] ¹			FDD
3				[6] ¹			FDD
4				[6] ¹			FDD
5				[6] ¹			FDD
6				[6] ¹			FDD
7				[6] ¹			FDD
8				[6] ¹			FDD
9				[6] ¹			FDD
10				[6] ¹			FDD
11				[6] ¹			FDD
12				[6] ¹			FDD
13				[6] ¹			FDD
14				[6] ¹			FDD
...							
17				[6] ¹			FDD
18				[6] ¹			FDD
19				[6] ¹			FDD
20				[6] ¹			FDD
21				[6] ¹			FDD
22				[6] ¹			FDD
23				[6] ¹			FDD
24				[6] ¹			FDD
...							
33				50			TDD
34				50			TDD
35				50			TDD
36				50			TDD
37				50			TDD
38				50			TDD
39				50			TDD
40				50			TDD
41				50			TDD
42				50			TDD
Note	<p>1. The UL resource blocks shall be located as close as possible to the downlink operating band but confined within the transmission bandwidth configuration for the channel bandwidth (Table 5.6-1).</p> <p>2. For the UE which supports both Band 11 and Band 21 the minimum uplink configuration for reference sensitivity is FFS.</p> <p>4. For Band 20; in the case of 15MHz channel bandwidth, the UL resource blocks shall be located at RBstart_{_11} and in the case of 20MHz channel bandwidth, the UL resource blocks shall be located at RBstart_{_16}</p>						

Unless given by Table G.2-3, the minimum requirements specified in Tables G.2-1 and G.2-2 shall be verified with the network signalling value NS_01 (Table 6.2.4-1) configured.

Table G.2-3: Network Signalling Value for reference sensitivity

E-UTRA Band	Network Signalling value
2	NS_03
4	NS_03
10	NS_03
12	NS_06
13	NS_06
14	NS_06
17	NS_06
19	NS_08
21	NS_09
23	NS_03
24	NS_56
35	NS_03
36	NS_03

G.3 Reference measurement channel for REFSENSE in lower SNR

Tables G.3-1 and G.3-2 are applicable for Annex G.2 (Reference sensitivity level in lower SNR).

Table G.3-1 Fixed Reference Channel for Receiver Requirements (FDD)

Parameter	Unit	Value
Channel bandwidth	MHz	10
Allocated resource blocks		50
Subcarriers per resource block		12
Allocated subframes per Radio Frame		10
Modulation		QPSK
Target Coding Rate		1/3
Number of HARQ Processes	Processes	8
Maximum number of HARQ transmissions		[4]
Information Bit Payload per Sub-Frame		
For Sub-Frames 1,2,3,4,6,7,8,9	Bits	4392
For Sub-Frame 5	Bits	n/a
For Sub-Frame 0	Bits	4392
Transport block CRC	Bits	24
Number of Code Blocks per Sub-Frame (Note 4)		
For Sub-Frames 1,2,3,4,6,7,8,9	Bits	1
For Sub-Frame 5	Bits	n/a
For Sub-Frame 0	Bits	1
Binary Channel Bits Per Sub-Frame		
For Sub-Frames 1,2,3,4,6,7,8,9	Bits	13800
For Sub-Frame 5	Bits	n/a
For Sub-Frame 0	Bits	12960
Max. Throughput averaged over 1 frame	kbps	3952.8
UE Category		1-8
Note 1: 2 symbols allocated to PDCCH for 20 MHz, 15 MHz and 10MHz channel BW. 3 symbols allocated to PDCCH for 5 MHz and 3 MHz. 4 symbols allocated to PDCCH for 1.4 MHz Note 2: Reference signal, Synchronization signals and PBCH allocated as per TS 36.211 [4] Note 3: If more than one Code Block is present, an additional CRC sequence of L = 24 Bits is attached to each Code Block (otherwise L = 0 Bit) Note 4: Redundancy version coding sequence is {0, 1, 2, 3} for QPSK.		

Table G.3-2 Fixed Reference Channel for Receiver Requirements (TDD)

Parameter	Unit	Value			
Channel Bandwidth	MHz			10	
Allocated resource blocks				50	
Uplink-Downlink Configuration (Note 5)				1	
Allocated subframes per Radio Frame (D+S)				4+2	
Number of HARQ Processes	Processes			7	
Maximum number of HARQ transmission				[4]	
Modulation				QPSK	
Target coding rate				1/3	
Information Bit Payload per Sub-Frame	Bits				
For Sub-Frame 4, 9				4392	
For Sub-Frame 1, 6				3240	
For Sub-Frame 5				n/a	
For Sub-Frame 0				4392	
Transport block CRC	Bits			24	
Number of Code Blocks per Sub-Frame (Note 5)					
For Sub-Frame 4, 9				1	
For Sub-Frame 1, 6				1	
For Sub-Frame 5				n/a	
For Sub-Frame 0				1	
Binary Channel Bits Per Sub-Frame	Bits				
For Sub-Frame 4, 9				13800	
For Sub-Frame 1, 6				11256	
For Sub-Frame 5				n/a	
For Sub-Frame 0				13104	
Max. Throughput averaged over 1 frame	kbps			1965.6	
UE Category				1-5	
<p>Note 1: For normal subframes(0,4,5,9), 2 symbols allocated to PDCCH for 20 MHz, 15 MHz and 10 MHz channel BW; 3 symbols allocated to PDCCH for 5 MHz and 3 MHz; 4 symbols allocated to PDCCH for 1.4 MHz. For special subframe (1&6), only 2 OFDM symbols are allocated to PDCCH for all BWs.</p> <p>Note 2: For 1.4MHz, no data shall be scheduled on special subframes(1&6) to avoid problems with insufficient PDCCH performance</p> <p>Note 3: Reference signal, Synchronization signals and PBCH allocated as per TS 36.211 [4]</p> <p>Note 4: If more than one Code Block is present, an additional CRC sequence of L = 24 Bits is attached to each Code Block (otherwise L = 0 Bit).</p> <p>Note 5: As per Table 4.2-2 in TS 36.211 [4]</p> <p>Note 6: Redundancy version coding sequence is {0, 1, 2, 3} for QPSK.</p>					

Annex H (normative): Modified MPR behavior

H.1 Indication of modified MPR behavior

This annex contains the definitions of the bits in the field *modifiedMPRbehavior* indicated in the IE UE Radio Access Capability [7] by a UE supporting an MPR or A-MPR modified in a later release of this specification.

Table H.1-1: Definitions of the bits in the field *modifiedMPRbehavior*

Index of field (bit number)	Definition (description of the supported functionality if indicator set to one)	Notes
0 (leftmost bit)	- The MPR for intra-band contiguous carrier aggregation bandwidth class C with non-contiguous resource allocation specified in Clause 6.2.3A in version 12.5.0 of this specification	- This bit can be set to 1 by a UE supporting intra-band contiguous CA bandwidth class C
1	- The A-MPR associated with NS_05 for Band 1 in Clause 6.2.4 in version 12.10.0 of this specification.	- This bit can be set to 1 by a UE supporting A-MPR associated to NS_05 for Band 1.
2	The A-MPR associated with NS_04 for Band 41 in Table 6.2.4-4 in version 14.1.0 of this specification.	This bit can be set to 1 by a power class 3 UE supporting A-MPR associated to NS_04 for Band 41.

Annex I (informative): Change history

Table H-1: Change History

Date	Meeting	TDoc	CR	Rev	Cat	Subject/Comment	New version
11-2007	R4#45	R4-72206				TS36.101V0.1.0 approved by RAN4	
12-2007	RP#38	RP-070979				Approved version at TSG RAN #38	8.0.0
03-2008	RP#39	RP-080123	3			TS36.101 - Combined updates of E-UTRA UE requirements	8.1.0
05-2008	RP#40	RP-080325	4			TS36.101 - Combined updates of E-UTRA UE requirements	8.2.0
09-2008	RP#41	RP-080638	5r1			Addition of Ref Sens figures for 1.4MHz and 3MHz Channel bandwidths	8.3.0
09-2008	RP#41	RP-080638	7r1			Transmitter intermodulation requirements	8.3.0
09-2008	RP#41	RP-080638	10			CR for clarification of additional spurious emission requirement	8.3.0
09-2008	RP#41	RP-080638	15			Correction of In-band Blocking Requirement	8.3.0
09-2008	RP#41	RP-080638	18r1			TS36.101: CR for section 6: NS_06	8.3.0
09-2008	RP#41	RP-080638	19r1			TS36.101: CR for section 6: Tx modulation	8.3.0
09-2008	RP#41	RP-080638	20r1			TS36.101: CR for UE minimum power	8.3.0
09-2008	RP#41	RP-080638	21r1			TS36.101: CR for UE OFF power	8.3.0
09-2008	RP#41	RP-080638	24r1			TS36.101: CR for section 7: Band 13 Rx sensitivity	8.3.0
09-2008	RP#41	RP-080638	26			UE EVM Windowing	8.3.0
09-2008	RP#41	RP-080638	29			Absolute ACLR limit	8.3.0
09-2008	RP#41	RP-080731	23r2			TS36.101: CR for section 6: UE to UE co-existence	8.3.0
09-2008	RP#41	RP-080731	30			Removal of [] for UE Ref Sens figures	8.3.0
09-2008	RP#41	RP-080731	31			Correction of PA, PB definition to align with RAN1 specification	8.3.0
09-2008	RP#41	RP-080731	37r2			UE Spurious emission band UE co-existence	8.3.0
09-2008	RP#41	RP-080731	44			Definition of specified bandwidths	8.3.0
09-2008	RP#41	RP-080731	48r3			Addition of Band 17	8.3.0
09-2008	RP#41	RP-080731	50			Alignment of the UE ACS requirement	8.3.0
09-2008	RP#41	RP-080731	52r1			Frequency range for Band 12	8.3.0
09-2008	RP#41	RP-080731	54r1			Absolute power tolerance for LTE UE power control	8.3.0
09-2008	RP#41	RP-080731	55			TS36.101 section 6: Tx modulation	8.3.0
09-2008	RP#41	RP-080732	6r2			DL FRC definition for UE Receiver tests	8.3.0
09-2008	RP#41	RP-080732	46			Additional UE demodulation test cases	8.3.0
09-2008	RP#41	RP-080732	47			Updated descriptions of FRC	8.3.0
09-2008	RP#41	RP-080732	49			Definition of UE transmission gap	8.3.0
09-2008	RP#41	RP-080732	51			Clarification on High Speed train model in 36.101	8.3.0
09-2008	RP#41	RP-080732	53			Update of symbol and definitions	8.3.0
09-2008	RP#41	RP-080743	56			Addition of MIMO (4x2) and (4x4) Correlation Matrices	8.3.0
12-2008	RP#42	RP-080908	94r2			CR TX RX channel frequency separation	8.4.0
12-2008	RP#42	RP-080909	105r1			UE Maximum output power for Band 13	8.4.0
12-2008	RP#42	RP-080909	60			UL EVM equalizer definition	8.4.0
12-2008	RP#42	RP-080909	63			Correction of UE spurious emissions	8.4.0
12-2008	RP#42	RP-080909	66			Clarification for UE additional spurious emissions	8.4.0
12-2008	RP#42	RP-080909	72			Introducing ACLR requirement for coexistence with UTRA 1.6MHZ channel from 36.803	8.4.0
12-2008	RP#42	RP-080909	75			Removal of [] from Section 6 transmitter characteristics	8.4.0
12-2008	RP#42	RP-080909	81			Clarification for PHS band protection	8.4.0
12-2008	RP#42	RP-080909	101			Alignment for the measurement interval for transmit signal quality	8.4.0
12-2008	RP#42	RP-080909	98r1			Maximum power	8.4.0
12-2008	RP#42	RP-080909	57r1			CR UE spectrum flatness	8.4.0
12-2008	RP#42	RP-080909	71r1			UE in-band emission	8.4.0
12-2008	RP#42	RP-080909	58r1			CR Number of TX exceptions	8.4.0
12-2008	RP#42	RP-080951	99r2			CR UE output power dynamic	8.4.0
12-2008	RP#42	RP-080951	79r1			LTE UE transmitter intermodulation	8.4.0
12-2008	RP#42	RP-080910	91			Update of Clause 8	8.4.0
12-2008	RP#42	RP-080950	106r1			Structure of Clause 9 including CSI requirements for PUCCH mode 1-0	8.4.0

12-2008	RP#42	RP-080911	59		CR UE ACS test frequency offset	8.4.0
12-2008	RP#42	RP-080911	65		Correction of spurious response parameters	8.4.0
12-2008	RP#42	RP-080911	80		Removal of LTE UE narrowband intermodulation	8.4.0
12-2008	RP#42	RP-080911	90r1		Introduction of Maximum Sensitivity Degradation	8.4.0
12-2008	RP#42	RP-080911	103		Removal of [] from Section 7 Receiver characteristic	8.4.0
12-2008	RP#42	RP-080912	62		Alignment of TB size n Ref Meas channel for RX characteristics	8.4.0
12-2008	RP#42	RP-080912	78		TDD Reference Measurement channel for RX characteristics	8.4.0
12-2008	RP#42	RP-080912	73r1		Addition of 64QAM DL reference measurement channel	8.4.0
12-2008	RP#42	RP-080912	74r1		Addition of UL Reference Measurement Channels	8.4.0
12-2008	RP#42	RP-080912	104		Reference measurement channels for PDSCH performance requirements (TDD)	8.4.0
12-2008	RP#42	RP-080913	68		MIMO Correlation Matrix Corrections	8.4.0
12-2008	RP#42	RP-080915	67		Correction to the figure with the Transmission Bandwidth configuration	8.4.0
12-2008	RP#42	RP-080916	77		Modification to EARFCN	8.4.0
12-2008	RP#42	RP-080917	85r1		New Clause 5 outline	8.4.0
12-2008	RP#42	RP-080919	102		Introduction of Bands 12 and 17 in 36.101	8.4.0
12-2008	RP#42	RP-080927	84r1		Clarification of HST propagation conditions	8.4.0
03-2009	RP#43	RP-090170	156r2		A-MPR table for NS_07	8.5.0
03-2009	RP#43	RP-090170	170		Corrections of references (References to tables and figures)	8.5.0
03-2009	RP#43	RP-090170	108		Removal of [] from Transmitter Intermodulation	8.5.0
03-2009	RP#43	RP-090170	155		E-UTRA ACLR for below 5 MHz bandwidths	8.5.0
03-2009	RP#43	RP-090170	116		Clarification of PHS band including the future plan	8.5.0
03-2009	RP#43	RP-090170	119		Spectrum emission mask for 1.4 MHz and 3 MHz bandwidths	8.5.0
03-2009	RP#43	RP-090170	120		Removal of "Out-of-synchronization handling of output power" heading	8.5.0
03-2009	RP#43	RP-090170	126		UE uplink power control	8.5.0
03-2009	RP#43	RP-090170	128		Transmission BW Configuration	8.5.0
03-2009	RP#43	RP-090170	130		Spectrum flatness	8.5.0
03-2009	RP#43	RP-090170	132r2		PUCCH EVM	8.5.0
03-2009	RP#43	RP-090170	134		UL DM-RS EVM	8.5.0
03-2009	RP#43	RP-090170	140		Removal of ACLR2bis requirements	8.5.0
03-2009	RP#43	RP-090171	113		In-band blocking	8.5.0
03-2009	RP#43	RP-090171	127		In-band blocking and sensitivity requirement for band 17	8.5.0
03-2009	RP#43	RP-090171	137r1		Wide band intermodulation	8.5.0
03-2009	RP#43	RP-090171	141		Correction of reference sensitivity power level of Band 9	8.5.0
03-2009	RP#43	RP-090172	109		AWGN level for UE DL demodulation performance tests	8.5.0
03-2009	RP#43	RP-090172	124		Update of Clause 8: additional test cases	8.5.0
03-2009	RP#43	RP-090172	139r1		Performance requirement structure for TDD PDSCH	8.5.0
03-2009	RP#43	RP-090172	142r1		Performance requirements and reference measurement channels for TDD PDSCH demodulation with UE-specific reference symbols	8.5.0
03-2009	RP#43	RP-090172	145		Number of information bits in DwPTS	8.5.0
03-2009	RP#43	RP-090172	160r1		MBSFN-Unicast demodulation test case	8.5.0
03-2009	RP#43	RP-090172	163r1		MBSFN-Unicast demodulation test case for TDD	8.5.0
03-2009	RP#43	RP-090173	162		Clarification of EARFCN for 36.101	8.5.0
03-2009	RP#43	RP-090369	110		Correction to UL Reference Measurement Channel	8.5.0
03-2009	RP#43	RP-090369	114		Addition of MIMO (4x4, medium) Correlation Matrix	8.5.0
03-2009	RP#43	RP-090369	121		Correction of 36.101 DL RMC table notes	8.5.0
03-2009	RP#43	RP-090369	125		Update of Clause 9	8.5.0
03-2009	RP#43	RP-090369	138r1		Clarification on OCN	8.5.0
03-2009	RP#43	RP-090369	161		CQI reference measurement channels	8.5.0
03-2009	RP#43	RP-090369	164		PUCCH 1-1 Static Test Case	8.5.0
03-2009	RP#43	RP-090369	111		Reference Measurement Channel for TDD	8.5.0

03-2009	RP#44				Editorial correction in Table 6.2.4-1	8.5.1
05-2009	RP#44	RP-090540	167		Boundary between E-UTRA fOOB and spurious emission domain for 1.4 MHz and 3 MHz bandwidths. (Technically Endorsed CR in R4-50bis - R4-091205)	8.6.0
05-2009	RP#44	RP-090540	168		EARFCN correction for TDD DL bands. (Technically Endorsed CR in R4-50bis - R4-091206)	8.6.0
05-2009	RP#44	RP-090540	169		Editorial correction to in-band blocking table. (Technically Endorsed CR in R4-50bis - R4-091238)	8.6.0
05-2009	RP#44	RP-090540	171		CR PRACH EVM. (Technically Endorsed CR in R4-50bis - R4-091308)	8.6.0
05-2009	RP#44	RP-090540	172		CR EVM correction. (Technically Endorsed CR in R4-50bis - R4-091309)	8.6.0
05-2009	RP#44	RP-090540	177		CR power control accuracy. (Technically Endorsed CR in R4-50bis - R4-091418)	8.6.0
05-2009	RP#44	RP-090540	179		Correction of SRS requirements. (Technically Endorsed CR in R4-50bis - R4-091426)	8.6.0
05-2009	RP#44	RP-090540	186		Clarification for EVM. (Technically Endorsed CR in R4-50bis - R4-091512)	8.6.0
05-2009	RP#44	RP-090540	187		Removal of [] from band 17 Refsens values and ACS offset frequencies	8.6.0
05-2009	RP#44	RP-090540	191		Completion of band17 requirements	8.6.0
05-2009	RP#44	RP-090540	192		Removal of 1.4 MHz and 3 MHz bandwidths from bands 13, 14 and 17.	8.6.0
05-2009	RP#44	RP-090540	223		CR: 64 QAM EVM	8.6.0
05-2009	RP#44	RP-090540	201		CR In-band emissions	8.6.0
05-2009	RP#44	RP-090540	203		CR EVM exclusion period	8.6.0
05-2009	RP#44	RP-090540	204		CR In-band emissions timing	8.6.0
05-2009	RP#44	RP-090540	206		CR Minimum Rx exceptions	8.6.0
05-2009	RP#44	RP-090540	207		CR UL DM-RS EVM	8.6.0
05-2009	RP#44	RP-090540	218r1		A-MPR table for NS_07	8.6.0
05-2009	RP#44	RP-090540	205r1		CR In-band emissions in shortened subframes	8.6.0
05-2009	RP#44	RP-090540	200r1		CR PUCCH EVM	8.6.0
05-2009	RP#44	RP-090540	178r2		No additional emission mask indication. (Technically Endorsed CR in R4-50bis - R4-091421)	8.6.0
05-2009	RP#44	RP-090540	220r1		Spectrum emission requirements for band 13	8.6.0
05-2009	RP#44	RP-090540	197r2		CR on aggregate power tolerance	8.6.0
05-2009	RP#44	RP-090540	196r2		CR: Rx IP2 performance	8.6.0
05-2009	RP#44	RP-090541	198r1		Maximum output power relaxation	8.6.0
05-2009	RP#44	RP-090542	166		Update of performance requirement for TDD PDSCH with MBSFN configuration. (Technically Endorsed CR in R4-50bis - R4-091180)	8.6.0
05-2009	RP#44	RP-090542	175		Adding AWGN levels for some TDD DL performance requirements. (Technically Endorsed CR in R4-50bis - R4-091406)	8.6.0
05-2009	RP#44	RP-090542	182		OCNG Patterns for Single Resource Block FRC Requirements. (Technically Endorsed CR in R4-50bis - R4-091504)	8.6.0
05-2009	RP#44	RP-090542	170r1		Update of Clause 8: PHICH and PMI delay. (Technically Endorsed CR in R4-50bis - R4-091275)	8.6.0
05-2009	RP#44	RP-090543	183		Requirements for frequency-selective fading test. (Technically Endorsed CR in R4-50bis - R4-091505)	8.6.0
05-2009	RP#44	RP-090543	199		CQI requirements under AWGN conditions	8.6.0
05-2009	RP#44	RP-090543	188r1		Adaptation of UL-RMC-s for supporting more UE categories	8.6.0
05-2009	RP#44	RP-090543	193r1		Correction of the LTE UE downlink reference measurement channels	8.6.0
05-2009	RP#44	RP-090543	184r1		Requirements for frequency non-selective fading tests. (Technically Endorsed CR in R4-50bis - R4-091506)	8.6.0
05-2009	RP#44	RP-090543	185r1		Requirements for PMI reporting. (Technically Endorsed CR in R4-50bis - R4-091510)	8.6.0
05-2009	RP#44	RP-090543	221r1		Correction to DL RMC-s for Maximum input level for supporting more UE-Categories	8.6.0
05-2009	RP#44	RP-090543	216		Addition of 15 MHz and 20 MHz bandwidths into band 38	8.6.0
05-2009	RP#44	RP-090559	180		Introduction of Extended LTE800 requirements. (Technically Endorsed CR in R4-50bis - R4-091432)	9.0.0
09-2009	RP#45	RP-090826	239		A-MPR for Band 19	9.1.0
09-2009	RP#45	RP-090822	225		LTE UTRA ACLR1 centre frequency definition for 1.4 and 3 MHz BW	9.1.0
09-2009	RP#45	RP-090822	227		Harmonization of text for LTE Carrier leakage	9.1.0
09-2009	RP#45	RP-090822	229		Sensitivity requirements for Band 38 15 MHz and 20 MHz bandwidths	9.1.0

09-2009	RP#45	RP-090822	236		Operating band edge relaxation of maximum output power for Band 18 and 19	9.1.0
09-2009	RP#45	RP-090822	238		Addition of 5MHz channel bandwidth for Band 40	9.1.0
09-2009	RP#45	RP-090822	245		Removal of unnecessary requirements for 1.4 and 3 MHz bandwidths on bands 13 and 17	9.1.0
09-2009	RP#45	RP-090877	261		Correction of LTE UE ACS test parameter	9.1.0
09-2009	RP#45	RP-090877	263R1		Correction of LTE UE ACLR test parameter	9.1.0
09-2009	RP#45	RP-090877	286		Uplink power and RB allocation for receiver tests	9.1.0
09-2009	RP#45	RP-090877	320		CR Sensitivity relaxation for small BW	9.1.0
09-2009	RP#45	RP-090877	324		Correction of Band 3 spurious emission band UE co-existence	9.1.0
09-2009	RP#45	RP-090877	249R1		CR P _{max} definition (working assumption)	9.1.0
09-2009	RP#45	RP-090877	330		Spectrum flatness clarification	9.1.0
09-2009	RP#45	RP-090877	332		Transmit power: removal of TC and modification of REFSSENS note	9.1.0
09-2009	RP#45	RP-090877	282R1		Additional SRS relative power requirement and update of measurement definition	9.1.0
09-2009	RP#45	RP-090877	284R1		Power range applicable for relative tolerance	9.1.0
09-2009	RP#45	RP-090878	233		TDD UL/DL configurations for CQI reporting	9.1.0
09-2009	RP#45	RP-090878	235		Further clarification on CQI test configurations	9.1.0
09-2009	RP#45	RP-090878	243		Corrections to UL- and DL-RMC-s	9.1.0
09-2009	RP#45	RP-090878	247		Reference measurement channel for multiple PMI requirements	9.1.0
09-2009	RP#45	RP-090878	290		CQI reporting test for a scenario with frequency-selective interference	9.1.0
09-2009	RP#45	RP-090878	265R2		CQI reference measurement channels	9.1.0
09-2009	RP#45	RP-090878	321R1		CR RI Test	9.1.0
09-2009	RP#45	RP-090875	231		Correction of parameters for demodulation performance requirement	9.1.0
09-2009	RP#45	RP-090875	241R1		UE categories for performance tests and correction to RMC references	9.1.0
09-2009	RP#45	RP-090875	333		Clarification of E_s definition in the demodulation requirement	9.1.0
09-2009	RP#45	RP-090875	326		Editorial corrections and updates to PHICH PBCH test cases.	9.1.0
09-2009	RP#45	RP-090875	259R3		Test case numbering in section 8 Performance tests	9.1.0
12-2009	RP-46	RP-091264	335		Test case numbering in TDD PDSCH performance test (Technically endorsed at RAN 4 52bis in R4-093523)	9.2.0
12-2009	RP-46	RP-091261	337		Adding beamforming model for user-specific reference signal (Technically endorsed at RAN 4 52bis in R4-093525)	9.2.0
12-2009	RP-46	RP-091263	339R1		Adding redundancy sequences to PMI test (Technically endorsed at RAN 4 52bis in R4-093581)	9.2.0
12-2009	RP-46	RP-091264	341		Throughput value correction at FRC for Maximum input level (Technically endorsed at RAN 4 52bis in R4-093660)	9.2.0
12-2009	RP-46	RP-091261	343		Correction to the modulated E-UTRA interferer (Technically endorsed at RAN 4 52bis in R4-093662)	9.2.0
12-2009	RP-46	RP-091264	345R1		OCNG: Patterns and present use in tests (Technically endorsed at RAN 4 52bis in R4-093664)	9.2.0
12-2009	RP-46	RP-091264	347		OCNG: Use in receiver and performance tests (Technically endorsed at RAN 4 52bis in R4-093666)	9.2.0
12-2009	RP-46	RP-091263	349		Miscellaneous corrections on CSI requirements (Technically endorsed at RAN 4 52bis in R4-093676)	9.2.0
12-2009	RP-46	RP-091261	351		Removal of RLC modes (Technically endorsed at RAN 4 52bis in R4-093677)	9.2.0
12-2009	RP-46	RP-091261	353		CR Rx diversity requirement (Technically endorsed at RAN 4 52bis in R4-093703)	9.2.0
12-2009	RP-46	RP-091261	355		A-MPR notation in NS_07 (Technically endorsed at RAN 4 52bis in R4-093706)	9.2.0
12-2009	RP-46	RP-091263	359		Single- and multi-PMI requirements (Technically endorsed at RAN 4 52bis in R4-093846)	9.2.0
12-2009	RP-46	RP-091263	363		CQI reference measurement channel (Technically endorsed at RAN 4 52bis in R4-093970)	9.2.0
12-2009	RP-46	RP-091292	364		LTE MBSFN Channel Model (Technically endorsed at RAN 4 52bis in R4-094020)	9.2.0
12-2009	RP-46	RP-091264	367		Numbering of PDSCH (User-Specific Reference Symbols) Demodulation Tests	9.2.0
12-2009	RP-46	RP-091264	369		Numbering of PDCCH/PCFICH, PHICH, PBCH Demod Tests	9.2.0
12-2009	RP-46	RP-091261	371		Remove [] from Reference Measurement Channels in Annex A	9.2.0

12-2009	RP-46	RP-091264	373R1		Corrections to RMC-s for Maximum input level test for low UE categories	9.2.0
12-2009	RP-46	RP-091261	377		Correction of UE-category for R.30	9.2.0
12-2009	RP-46	RP-091286	378		Introduction of Extended LTE1500 requirements for TS36.101	9.2.0
12-2009	RP-46	RP-091262	384		CR: Removal of 1.4 MHz and 3 MHz channel bandwidths from additional spurious emissions requirements for Band 1 PHS protection	9.2.0
12-2009	RP-46	RP-091262	386R3		Clarification of measurement conditions of spurious emission requirements at the edge of spurious domain	9.2.0
12-2009	RP-46	RP-091262	390		Spurious emission table correction for TDD bands 33 and 38.	9.2.0
12-2009	RP-46	RP-091262	392R2		36.101 Symbols and abbreviations for P _{max}	9.2.0
12-2009	RP-46	RP-091262	394		UTRAACLR1 requirement definition for 1.4 and 3 MHz BW completed	9.2.0
12-2009	RP-46	RP-091263	396		Introduction of the ACK/NACK feedback modes for TDD requirements	9.2.0
12-2009	RP-46	RP-091262	404R3		CR Power control exception R8	9.2.0
12-2009	RP-46	RP-091262	416R1		Relative power tolerance: special case for receiver tests	9.2.0
12-2009	RP-46	RP-091263	420R1		CSI reporting: test configuration for CQI fading requirements	9.2.0
12-2009	RP-46	RP-091284	421R1		Inclusion of Band 20 UE RF parameters	9.2.0
12-2009	RP-46	RP-091264	425		Editorial corrections and updates to Clause 8.2.1 FDD demodulation test cases	9.2.0
12-2009	RP-46	RP-091262	427		CR: time mask	9.2.0
12-2009	RP-46	RP-091264	430		Correction of the payload size for PDCCH/PCFICH performance requirements	9.2.0
12-2009	RP-46	RP-091263	432		Transport format and test point updates to RI reporting test cases	9.2.0
12-2009	RP-46	RP-091263	434		Transport format and test setup updates to frequency-selective interference CQI tests	9.2.0
12-2009	RP-46	RP-091263	436		CR RI reporting configuration in PUCCH 1-1 test	9.2.0
12-2009	RP-46	RP-091261	438		Addition of R.11-1 TDD references	9.2.0
12-2009	RP-46	RP-091292	439		Performance requirements for LTE MBMS	9.2.0
12-2009	RP-46	RP-091262	442R1		In Band Emissions Requirements Correction CR	9.2.0
12-2009	RP-46	RP-091262	444R1		PCMAX definition	9.2.0
03-2010	RP-47	RP-100246	453r1		Corrections of various errors in the UE RF requirements	9.3.0
03-2010	RP-47	RP-100246	462r1		UTRA ACLR measurement bandwidths for 1.4 and 3 MHz	9.3.0
03-2010	RP-47	RP-100246	493		Band 8 Coexistence Requirement Table Correction	9.3.0
03-2010	RP-47	RP-100246	489r1		Rel 9 CR for Band 14	9.3.0
03-2010	RP-47	RP-100246	485r1		CR Band 1- PHS coexistence	9.3.0
03-2010	RP-47	RP-100247	501		Fading CQI requirements for FDD mode	9.3.0
03-2010	RP-47	RP-100247	499		CR correction to RI test	9.3.0
03-2010	RP-47	RP-100249	451		Reporting mode, Reporting Interval and Editorial corrections for demodulation	9.3.0
03-2010	RP-47	RP-100249	464r1		Corrections to 1PRB PDSCH performance test in presence of MBSFN.	9.3.0
03-2010	RP-47	RP-100249	458r1		OCNG corrections	9.3.0
03-2010	RP-47	RP-100249	467		Addition of ONCG configuration in DRS performance test	9.3.0
03-2010	RP-47	RP-100249	465r1		PDSCH performance tests for low UE categories	9.3.0
03-2010	RP-47	RP-100250	460r1		Use of ONCG in CSI tests	9.3.0
03-2010	RP-47	RP-100250	491r1		Corrections to CQI test configurations	9.3.0
03-2010	RP-47	RP-100250	469r1		Corrections of some CSI test parameters	9.3.0
03-2010	RP-47	RP-100251	456r1		TBS correction for RMC UL TDD 16QAM full allocation BW 1.4 MHz	9.3.0
03-2010	RP-47	RP-100262	449		Editorial corrections on Band 19 REFSENS	9.3.0
03-2010	RP-47	RP-100263	470r1		Band 20 UE RF requirements	9.3.0
03-2010	RP-47	RP-100264	446r1		A-MPR for Band 21	9.3.0
03-2010	RP-47	RP-100264	448		RF requirements for UE in later releases	9.3.0
03-2010	RP-47	RP-100268	445		36.101 CR: Editorial corrections on LTE MBMS reference measurement channels	9.3.0
03-2010	RP-47	RP-100268	454		The definition of the Doppler shift for LTE MBSFN	9.3.0

					Channel Model	
03-2010	RP-47	RP-100239	478r3		Modification of the spectral flatness requirement and some editorial corrections	9.3.0
06-2010	RP-48	RP-100619	559		Corrections of tables for Additional Spectrum Emission Mask	9.4.0
06-2010	RP-48	RP-100619	538		Correction of transient time definition for EVM requirements	9.4.0
06-2010	RP-48	RP-100619	557r2		CR on UE coexistence requirement	9.4.0
06-2010	RP-48	RP-100619	547r1		Correction of antenna configuration and beam-forming model for DRS	9.4.0
06-2010	RP-48	RP-100619	536r1		CR: Corrections on MIMO demodulation performance requirements	9.4.0
06-2010	RP-48	RP-100619	528r1		Corrections on the definition of PCMAX	9.4.0
06-2010	RP-48	RP-100619	568		Relaxation of the PDSCH demodulation requirements due to control channel errors	9.4.0
06-2010	RP-48	RP-100619	566		Correction of the UE output power definition for RX tests	9.4.0
06-2010	RP-48	RP-100620	505r1		Fading CQI requirements for TDD mode	9.4.0
06-2010	RP-48	RP-100620	521		Correction to FRC for CQI index 0	9.4.0
06-2010	RP-48	RP-100620	516r1		Correction to CQI test configuration	9.4.0
06-2010	RP-48	RP-100620	532		Correction of CQI and PMI delay configuration description for TDD	9.4.0
06-2010	RP-48	RP-100620	574		Correction to FDD and TDD CSI test configurations	9.4.0
06-2010	RP-48	RP-100620	571		Minimum requirements for Rank indicator reporting	9.4.0
06-2010	RP-48	RP-100628	563		LTE MBMS performance requirements (FDD)	9.4.0
06-2010	RP-48	RP-100628	564		LTE MBMS performance requirements (TDD)	9.4.0
06-2010	RP-48	RP-100629	553r2		Performance requirements for dual-layer beamforming	9.4.0
06-2010	RP-48	RP-100630	524r2		CR: low Category CSI requirement	9.4.0
06-2010	RP-48	RP-100630	519		Correction of FRC reference and test case numbering	9.4.0
06-2010	RP-48	RP-100630	526		Correction of carrier frequency and EARFCN of Band 21 for TS36.101	9.4.0
06-2010	RP-48	RP-100630	508r1		Addition of PDSCH TDD DRS demodulation tests for Low UE categories	9.4.0
06-2010	RP-48	RP-100630	539		Specification of minimum performance requirements for low UE category	9.4.0
06-2010	RP-48	RP-100630	569		Addition of minimum performance requirements for low UE category TDD CRS single-antenna port tests	9.4.0
06-2010	RP-48	RP-100631	549r3		Introduction of sustained downlink data-rate performance requirements	9.4.0
06-2010	RP-48	RP-100683	530r1		Band 20 Rx requirements	9.4.0
09-2010	RP-49	RP-100920	614r2		Add OCNG to MBMS requirements	9.5.0
09-2010	RP-49	RP-100916	599		Correction of PDCCH content for PHICH test	9.5.0
09-2010	RP-49	RP-100920	597r1		Beamforming model for transmission on antenna port 7/8	9.5.0
09-2010	RP-49	RP-100920	600r1		Correction of full correlation in frequency-selective CQI test	9.5.0
09-2010	RP-49	RP-100920	601		Correction on single-antenna transmission fixed reference channel	9.5.0
09-2010	RP-49	RP-100914	605		Reference sensitivity requirements for the 1.4 and 3 MHz bandwidths	9.5.0
09-2010	RP-49	RP-100920	608r1		CR for DL sustained data rate test	9.5.0
09-2010	RP-49	RP-100919	611		Correction of references in section 10 (MBMS performance requirements)	9.5.0
09-2010	RP-49	RP-100914	613		Band 13 and Band 14 spurious emission corrections	9.5.0
09-2010	RP-49	RP-100919	617r1		Rx Requirements	9.5.0
09-2010	RP-49	RP-100926	576r1		Clarification on DL-BF simulation assumptions	9.5.0
09-2010	RP-49	RP-100920	582r1		Introduction of additional Rel-9 scenarios	9.5.0
09-2010	RP-49	RP-100925	575r1		Correction to band 20 ue to ue Co-existence table	9.5.0
09-2010	RP-49	RP-100916	581r1		Test configuration corrections to CQI reporting in AWGN	9.5.0
09-2010	RP-49	RP-100916	595		Corrections to RF OCNG Pattern OP.1 and 2	9.5.0
09-2010	RP-49	RP-100919	583		Editorial corrections of 36.101	9.5.0
09-2010	RP-49	RP-100920	586		Addition of minimum performance requirements for low UE category TDD tests	9.5.0
09-2010	RP-49	RP-100914	590r1		Downlink power for receiver tests	9.5.0
09-2010	RP-49	RP-100920	591		OCNG use and power in beamforming tests	9.5.0
09-2010	RP-49	RP-100916	593		Throughput for multi-datastreams transmissions	9.5.0
09-2010	RP-49	RP-100914	588		Missing note in Additional spurious emission test with NS_07	9.5.0
09-2010	RP-49	RP-100927	596r2		CR LTE_TDD_2600_US spectrum band definition additions to TS 36.101	10.0.0
12-2010	RP-50	RP-101309	680		Demodulation performance requirements for dual-layer beamforming	10.1.0
12-2010	RP-50	RP-101325	672		Correction on the statement of TB size and subband selection in CSI tests	10.1.0
12-2010	RP-50	RP-101327	652		Correction to Band 12 frequency range	10.1.0

12-2010	RP-50	RP-101329	630		Removal of [] from TDD Rank Indicator requirements	10.1.0
12-2010	RP-50	RP-101329	635r1		Test configuration corrections to CQI TDD reporting in AWGN (Rel-10)	10.1.0
12-2010	RP-50	RP-101330	645		EVM window length for PRACH	10.1.0
12-2010	RP-50	RP-101330	649		Removal of NS signalling from TDD REFSENS tests	10.1.0
12-2010	RP-50	RP-101330	642r1		Correction of Note 4 In Table 7.3.1-1: Reference sensitivity QPSK PREFSENS	10.1.0
12-2010	RP-50	RP-101341	627		Add 20 RB UL Ref Meas channel	10.1.0
12-2010	RP-50	RP-101341	654r1		Additional in-band blocking requirement for Band 12	10.1.0
12-2010	RP-50	RP-101341	678		Further clarifications for the Sustained Downlink Data Rate Test	10.1.0
12-2010	RP-50	RP-101341	673r1		Correction on MBMS performance requirements	10.1.0
12-2010	RP-50	RP-101349	667r3		CR Removing brackets of Band 41 reference sensitivity to TS 36.101	10.1.0
12-2010	RP-50	RP-101356	666r2		Band 42 and 43 parameters for UMTS/LTE 3500 (TDD) for TS 36.101	10.1.0
12-2010	RP-50	RP-101359	646r1		CR for CA, UL-MIMO, eDL-MIMO, CPE	10.1.0
12-2010	RP-50	RP-101361	620r1		Introduction of L-band in TS 36.101	10.1.0
12-2010	RP-50	RP-101379	670r1		Correction on the PMI reporting in Multi-Layer Spatial Multiplexing performance test	10.1.0
12-2010	RP-50	RP-101380	679r1		Adding antenna configuration in CQI fading test case	10.1.0
01-2011					Clause numbering correction	10.1.1
03-2011	RP-51	RP-110359	695		Removal of E-UTRA ACLR for CA	10.2.0
03-2011	RP-51	RP-110338	699		PDCCH and PHICH performance: OCNG and power settings	10.2.0
03-2011	RP-51	RP-110336	706r1		Spurious emissions measurement uncertainty	10.2.0
03-2011	RP-51	RP-110352	707r1		REFSENSE in lower SNR	10.2.0
03-2011	RP-51	RP-110338	710		PMI performance: Power settings and precoding granularity	10.2.0
03-2011	RP-51	RP-110359	715r2		Definition of configured transmitted power for Rel-10	10.2.0
03-2011	RP-51	RP-110359	717		Introduction of requirement for adjacent intraband CA image rejection	10.2.0
03-2011	RP-51	RP-110343	719		Minimum requirements for the additional Rel-9 scenarios	10.2.0
03-2011	RP-51	RP-110343	723		Corrections to power settings for Single layer beamforming with simultaneous transmission	10.2.0
03-2011	RP-51	RP-110343	726r1		Correction to the PUSCH3-0 subband tests for Rel-10	10.2.0
03-2011	RP-51	RP-110338	730		Removing the square bracket for TS36.101	10.2.0
03-2011	RP-51	RP-110349	739		Removal of square brackets for dual-layer beamforming demodulation performance requirements	10.2.0
03-2011	RP-51	RP-110359	751		CR: Maximum input level for intra band CA	10.2.0
03-2011	RP-51	RP-110349	754r2		UE category coverage for dual-layer beamforming	10.2.0
03-2011	RP-51	RP-110343	756r1		Further clarifications for the Sustained Downlink Data Rate Test	10.2.0
03-2011	RP-51	RP-110343	759		Removal of square brackets in sustained data rate tests	10.2.0
03-2011	RP-51	RP-110337	762r1		Clarification to LTE relative power tolerance table	10.2.0
03-2011	RP-51	RP-110343	764		Introducing UE-selected subband CQI tests	10.2.0
03-2011	RP-51	RP-110343	765		Verification framework for PUSCH 2-2 and PUCCH 2-1 reporting	10.2.0
04-2011					Editorial: Spec Title correction, removal of "Draft"	10.2.1
06-2011	RP-52	RP-110804	766		Add Expanded 1900MHz Band (Band 25) in 36.101	10.3.0
06-2011	RP-52	RP-110795	768		Fixing Band 24 inclusion in TS 36.101	10.3.0
06-2011	RP-52	RP-110788	772		CR: Corrections for UE to UE co-existence requirements of Band 3	10.3.0
06-2011	RP-52	RP-110812	774		Add 2GHz S-Band (Band 23) in 36.101	10.3.0
06-2011	RP-52	RP-110789	782		CR: Band 19 A-MPR refinement	10.3.0
06-2011	RP-52	RP-110796	787		REFSENS in lower SNR	10.3.0
06-2011	RP-52	RP-110789	805		Clarification for MBMS reference signal levels	10.3.0
06-2011	RP-52	RP-110792	810		FDD MBMS performance requirements for 64QAM mode	10.3.0
06-2011	RP-52	RP-110787	814		Correction on CQI mapping index of RI test	10.3.0
06-2011	RP-52	RP-110789	824		Corrections to in-band blocking table	10.3.0
06-2011	RP-52	RP-110794	826		Correction of TDD Category 1 DRS and DMRS RMCs	10.3.0
06-2011	RP-52	RP-110794	828		TDD MBMS performance requirements for 64QAM mode	10.3.0
06-2011	RP-52	RP-110796	829		Correction of TDD RMC for Low SNR Demodulation test	10.3.0
06-2011	RP-52	RP-110796	830		Informative reference sensitivity requirements for Low SNR for TDD	10.3.0
06-2011	RP-52	RP-110787	778r1		Minor corrections to DL-RMC-s for Maximum input level	10.3.0
06-2011	RP-52	RP-110789	832		PDCCH and PHICH performance: OCNG and power settings	10.3.0
06-2011	RP-52	RP-110789	818r1		Correction on 2-X PMI test for R10	10.3.0
06-2011	RP-52	RP-110791	816r1		Addition of performance requirements for dual-layer beamforming category 1 UE test	10.3.0
06-2011	RP-52	RP-110789	834		Performance requirements for PUCCH 2-0, PUCCH 2-1 and PUSCH 2-2 tests	10.3.0
06-2011	RP-52	RP-110807	835r1		CR for UL MIMO and CA	10.3.0

09-2011	RP-53	RP-111248	862r1		Removal of unnecessary channel bandwidths from REFSSENS tables	10.4.0
09-2011	RP-53	RP-111248	869r1		Clarification on BS precoding information field for RI FDD and PUCCH 2-1 PMI tests	10.4.0
09-2011	RP-53	RP-111248	872r1		CR for B14Rx requirement Rrel 10	10.4.0
09-2011	RP-53	RP-111248	890r1		CR to TS36.101: Correction on the accuracy test of CQI.	10.4.0
09-2011	RP-53	RP-111248	893		CR to TS36.101: Correction on CQI mapping index of TDD RI test	10.4.0
09-2011	RP-53	RP-111248	904		Correction of code block numbers for some RMCs	10.4.0
09-2011	RP-53	RP-111248	907		Correction to UL RMC for FDD and TDD	10.4.0
09-2011	RP-53	RP-111248	914r1		Adding codebook subset restriction for single layer closed-loop spatial multiplexing test	10.4.0
09-2011	RP-53	RP-111251	883		Sustained data rate: Correction of the ACK/NACK feedback mode	10.4.0
09-2011	RP-53	RP-111251	929		36.101 CR on MBSFN FDD requirements(R10)	10.4.0
09-2011	RP-53	RP-111251	938		TDD MBMS performance requirements for 64QAM mode	10.4.0
09-2011	RP-53	RP-111252	895		Further clarification for the dual-layer beamforming demodulation requirements	10.4.0
09-2011	RP-53	RP-111255	908r1		Introduction of Band 22	10.4.0
09-2011	RP-53	RP-111255	939		Modifications of Band 42 and 43	10.4.0
09-2011	RP-53	RP-111260	944		CR for TS 36.101 Annex B: Static channels for CQI tests	10.4.0
09-2011	RP-53	RP-111262	878r1		Correction of CSI reference channel subframe description	10.4.0
09-2011	RP-53	RP-111262	887		Correction to UL MIMO	10.4.0
09-2011	RP-53	RP-111262	926r1		Power control accuracy for intra-band carrier aggregation	10.4.0
09-2011	RP-53	RP-111262	927r1		In-band emissions requirements for intra-band carrier aggregation	10.4.0
09-2011	RP-53	RP-111262	930r1		Adding the operating band for UL-MIMO	10.4.0
09-2011	RP-53	RP-111265	848		Corrections to intra-band contiguous CA RX requirements	10.4.0
09-2011	RP-53	RP-111265	863		Intra-band contiguous CA MPR requirement refinement	10.4.0
09-2011	RP-53	RP-111265	866r1		Intra-band contiguous CA EVM	10.4.0
09-2011	RP-53	RP-111266	935		Introduction of the downlink CA demodulation requirements	10.4.0
09-2011	RP-53	RP-111266	936r1		Introduction of CA UE demodulation requirements for TDD	10.4.0
12-2011	RP-54	RP-111684	947		Corrections of UE categories of Rel-10 reference channels for RF requirements	10.5.0
12-2011	RP-54	RP-111684	948		Alternative way to define channel bandwidths per operating band for	10.5.0
12-2011	RP-54	RP-111686	949		CR for TS36.101: Adding note to the function of MPR	10.5.0
12-2011	RP-54	RP-111680	950		Clarification on applying CSI reports during rank switching in RI FDD test - Rel-10	10.5.0
12-2011	RP-54	RP-111734	953r1		Corrections for Band 42 and 43 introduction	10.5.0
12-2011	RP-54	RP-111680	956		UE spurious emissions	10.5.0
12-2011	RP-54	RP-111682	959		Add scrambling identity n_SCID for MU-MIMO test	10.5.0
12-2011	RP-54	RP-111690	960r1		P-MPR definition	10.5.0
12-2011	RP-54	RP-111693	962		P _{cmx,c} Computation Assumptions	10.5.0
12-2011	RP-54	RP-111733	963r1		Correction of frequency range for spurious emission requirements	10.5.0
12-2011	RP-54	RP-111680	966		General review of the reference measurement channels	10.5.0
12-2011	RP-54	RP-111691	945		Corrections of Rel-10 demodulation performance requirements This CR is only partially implemented due to confliction with CR 966	10.5.0
12-2011	RP-54	RP-111684	946		Corrections of UE categories for Rel-10 CSI requirements This CR is only partially implemented due to confliction with CR 966	10.5.0
12-2011	RP-54	RP-111691	982r2		Introduction of SDR TDD test scenario for CA UE demodulation This CR is only partially implemented due to confliction with CR 966	10.5.0
12-2011	RP-54	RP-111693	971r1		CR on Colliding CRS for non-MBSFN ABS	10.5.0
12-2011	RP-54	RP-111693	972r1		Introduction of eICIC demodulation performance requirements for FDD and TDD	10.5.0
12-2011	RP-54	RP-111686	985		Adding missing UL configuration specification in some UE receiver requirements for case of 1 CC UL capable UE	10.5.0
12-2011	RP-54	RP-111684	998		Correction and maintenance on CQI and PMI requirements (Rel-10)	10.5.0
12-2011	RP-54	RP-111735	1004		MPR for CA Multi-cluster	10.5.0
12-2011	RP-54	RP-111691	1005		CA demodulation performance requirements for LTE FDD	10.5.0

12-2011	RP-54	RP-111692	1006			CQI reporting accuracy test on frequency non-selective scheduling on eDL MIMO	10.5.0
12-2011	RP-54	RP-111692	1007			CQI reporting accuracy test on frequency-selective scheduling on eDL MIMO	10.5.0
12-2011	RP-54	RP-111692	1008			PMI reporting accuracy test for TDD on eDL MIMO	10.5.0
12-2011	RP-54	RP-111692	1009r 1			CR for TS 36.101: RI performance requirements	10.5.0
12-2011	RP-54	RP-111692	1010r 1			CR for TS 36.101: Introduction of static CQI tests (Rel-10)	10.5.0
03-2012	RP-55	RP-120291	1014			RF: Updates and corrections to the RMC-s related annexes (Rel-10)	10.6.0
03-2012	RP-55	RP-120300	1015r 1			On eICIC ABS pattern	10.6.0
03-2012	RP-55	RP-120300	1016r 1			On eICIC interference models	10.6.0
03-2012	RP-55	RP-120299	1017r 1			TS36.101 CR: on eDL-MIMO channel model using cross-polarized antennas	10.6.0
03-2012	RP-55	RP-120304	1020r 1			TS36.101 CR: Correction to MBMS Performance Test Parameters	10.6.0
03-2012	RP-55	RP-120303	1021			Harmonic exceptions in LTE UE to UE co-ex tests	10.6.0
03-2012	RP-55	RP-120304	1023			Unified titles for Rel-10 CSI tests	10.6.0
03-2012	RP-55	RP-120300	1033r 1			Introduction of reference channel for eICIC demodulation	10.6.0
03-2012	RP-55	RP-120304	1040r 1			Correction of Actual code rate for CSI RMCs	10.6.0
03-2012	RP-55	RP-120304	1041r 1			Definition of synchronized operation	10.6.0
03-2012	RP-55	RP-120296	1048r 1			Intra band contiguous CA Ue to Ue Co-ex	10.6.0
03-2012	RP-55	RP-120296	1049r 1			REL-10 CA specification editorial consistency	10.6.0
03-2012	RP-55	RP-120299	1053			Beamforming model for TM9	10.6.0
03-2012	RP-55	RP-120296	1054			Requirement for CA demodulation with power imbalance	10.6.0
03-2012	RP-55	RP-120298	1057			Updating Band 23 duplex specifications	10.6.0
03-2012	RP-55	RP-120298	1058r 1			Correcting UE Coexistence Requirements for Band 23	10.6.0
03-2012	RP-55	RP-120304	1059r 1			CA demodulation performance requirements for LTE TDD	10.6.0
03-2012	RP-55	RP-120304	1061			Requirement for CA SDR FDD test scenario	10.6.0
03-2012	RP-55	RP-120293	1064r 1			TS36.101 RF editorial corrections Rel 10	10.6.0
03-2012	RP-55	RP-120299	1067r 1			Introduction of TM9 demodulation performance requirements	10.6.0
03-2012	RP-55	RP-120304	1071r 1			Introduction of a CA demodulation test for UE soft buffer management testing	10.6.0
03-2012	RP-55	RP-120296	1072			MPR formula correction For intra-band contiguous CA Bandwidth Class C	10.6.0
03-2012	RP-55	RP-120303	1077r 1			CR for 36.101: B41 REFSSENS and MOP changes to accommodate single filter architecture	10.6.0
03-2012	RP-55	RP-120300	1082			TM3 tests for eICIC	10.6.0
03-2012	RP-55	RP-120300	1083r 1			Introduction of requirements of CQI reporting definition for eICIC	10.6.0
03-2012	RP-55	RP-120304	1084			eDL MIMO CSI requirements	10.6.0
06-2012	RP-56	RP-120777	1086r 1			Carrier aggregation Relative power tolerance, removal of TBD.	10.7.0
06-2012	RP-56	RP-120783	1088			UE spurious emissions for Band 7 and Band 38 coexistence	10.7.0
06-2012	RP-56	RP-120780	1091			Deleting square brackets in Reference Measurement Channels	10.7.0
06-2012	RP-56	RP-120773	1093			Addition of Maximum Throughput for R.30-1 TDD RMC	10.7.0
06-2012	RP-56	RP-120779	1095			CR to TS36.101: Correction on parameters for the eDL-MIMO CQI and PMI tests	10.7.0
06-2012	RP-56	RP-120780	1096r 1			CR to TS36.101: Fixed reference channel for PDSCH demodulation performance requirements on eDL-MIMO – NOT implemented as it is based on a wrong version of the Spec	10.7.0
06-2012	RP-56	RP-120779	1100r 1			CR for 36.101: The clarification of MPR and A-MPR for CA	10.7.0
06-2012	RP-56	RP-120784	1101			Corrections for eICIC demod test case with MBSN ABS	10.7.0
06-2012	RP-56	RP-120774	1106			RMC correction on eDL-MIMO RI test	10.7.0
06-2012	RP-56	RP-120774	1109r 1			FRC correction on frequency selective CQI and PMI test (Rel-10)	10.7.0
06-2012	RP-56	RP-120784	1110r 1			Corrections and clarifications on eICIC demodulation tests	10.7.0
06-2012	RP-56	RP-120774	1113			Correction on test point for PMI test (Rel-10)	10.7.0

06-2012	RP-56	RP-120784	1116r 1			Corrections and clarifications on eICIC CSI tes	10.7.0
06-2012	RP-56	RP-120783	1118r 1			Corrections on UE performance requirements	10.7.0
06-2012	RP-56	RP-120769	1126r 1			Addition of ETU30 channel model	10.7.0
06-2012	RP-56	RP-120779	1129r 1			CR for EVM and global in channel test for Intra-Band CA	10.7.0
06-2012	RP-56	RP-120784	1146r 1			Extension of static eICIC CQI test	10.7.0
06-2012	RP-56	RP-120784	1148r 2			Introduction of PDCCH test with colliding RS on MBSFN-ABS	10.7.0
06-2012	RP-56	RP-120784	1152r 2			Some clarifications and OCNG pattern for eICIC demodulation requirements	10.7.0
06-2012	RP-56	RP-120773	1154			Introduction of TDD CA Soft Buffer Limitation	10.7.0
06-2012	RP-56	RP-120779	1160			Corrections on CQI and PMI test	10.7.0
06-2012	RP-56	RP-120780	1162			FRC for TDD PMI test	10.7.0
06-2012	RP-56	RP-120778	1164r 1			Clean-up of UL-MIMO for TS36.101	10.7.0
06-2012	RP-56	RP-120782	1168r 1			SNR definition	10.7.0
06-2012	RP-56	RP-120782	1170			Removal of unnecessary references to single carrier requirements from Interband CA sub-clauses	10.7.0
06-2012	RP-56	RP-120780	1172			Editorial simplification to CA REFSSENS UL allocation table	10.7.0
06-2012	RP-56	RP-120781	1173			PDCCH wrong detection in receiver spurious emissions test	10.7.0
06-2012	RP-56	RP-120776	1183			Corrections to 3500 MHz	10.7.0
06-2012	RP-56	RP-120784	1192r 1			Target SNR setting for eICIC demodulation requirement	10.7.0
06-2012	RP-56	RP-120778	1198			Correction of wrong table refernces in CA receiver tests	10.7.0
06-2012	RP-56	RP-120782	1201r 2			SNR reference values for FDD CA soft buffer tests	10.7.0
06-2012	RP-56	RP-120764	1211			Correction of PHS protection requirements for TS 36.101	10.7.0
06-2012	RP-56	RP-120781	1214r 1			Proposed revision of subclause 4.3A for TS36.101	10.7.0
06-2012	RP-56	RP-120781	1216r 1			Proposed revision on subclause 6.3.4A for TS36.101	10.7.0
06-2012	RP-56	RP-120778	1222			Correction of CSI configuraiton for CA TM4 tests R10	10.7.0
06-2012	RP-56	RP-120773	1224			CR on CA UE receiver timing window R10	10.7.0
09-2012	RP-57	RP-121294	1229			Correct Transport Block size in 9RB 16QAM Uplink Reference Measurement Channel	10.8.0
09-2012	RP-57	RP-121313	1232r 1			RF: Corrections to power allocation parameters for transmission mode 8	10.8.0
09-2012	RP-57	RP-121304	1234			RF-CA: non-CA notation and applicability of test points in scenarios without and with CA operation	10.8.0
09-2012	RP-57	RP-121305	1236			ACK/NACK feedback modes for FDD and TDD TM4 CA demodulation requirements (Rel-10)	10.8.0
09-2012	RP-57	RP-121305	1238			Correction of feedback mode for CA TDD demodulation requirements (resubmission of R4-63AH-0194 for Rel-10)	10.8.0
09-2012	RP-57	RP-121302	1240			ABS pattern setup for MBSFN ABS test (resubmission of R4-63AH-0204 for Rel-10)	10.8.0
09-2012	RP-57	RP-121302	1242			CR on eICIC CQI definition test (resubmission of R4-63AH-0205 for Rel-10)	10.8.0
09-2012	RP-57	RP-121302	1244r 1			Transmission of CQI feedback and other corrections (Rel-10)	10.8.0
09-2012	RP-57	RP-121302	1246r 1			Target SNR setting for eICIC MBSFN-ABS demodulation requirements (Rel-10)	10.8.0
09-2012	RP-57	RP-121300	1250			Corrections of spurious emission band UE co-existence applicable in Japan	10.8.0
09-2012	RP-57	RP-121306	1252			Correction on RMC for frequency non-selective CQI test	10.8.0
09-2012	RP-57	RP-121306	1254r 1			Requirements for the eDL-MIMO CQI test	10.8.0
09-2012	RP-57	RP-121302	1256r 1			Clarification on PDSCH test setup under MBSFN ABS	10.8.0
09-2012	RP-57	RP-121313	1261r 1			Applicability of statement allowing RBW < Meas BW for spurious	10.8.0
09-2012	RP-57	RP-121298	1264			Clarification of RB allocation for DRS demodulation tests	10.8.0
09-2012	RP-57	RP-121304	1266r 1			Removal of brackets for CA Tx	10.8.0
09-2012	RP-57	RP-121313	1270			Corrections of FRC subframe allocations and other minor problems	10.8.0
09-2012	RP-57	RP-121305	1272			Adding missed code rate of R.35-1 TDD for R10	10.8.0
09-2012	RP-57	RP-121305	1273r			Introduction of requirements for TDD CA Soft Buffer	10.8.0

			1			Limitation	
09-2012	RP-57	RP-121307	1275r 1			Correction of eDL-MIMO CSI RMC tables and references	10.8.0
09-2012	RP-57	RP-121307	1277			Correction of MIMO channel model for polarized antennas	10.8.0
09-2012	RP-57	RP-121303	1279r 1			Addition of 15 and 20MHz Bandwidths for Band 23 to TS 36.101 (Rel-10)	10.8.0
09-2012	RP-57	RP-121304	1284r 1			CR for A-MPR masks for NS_CA_1C	10.8.0
09-2012	RP-57	RP-121446	1287r 2			Introduction of Japanese Regulatory Requirements to LTE Band 8(R10)	10.8.0
09-2012	RP-57	RP-121306	1297r 1			Requirements for eDL-MIMO RI test	10.8.0
09-2012	RP-57	RP-121306	1303			Corrections to TM9 demodulation tests	10.8.0
09-2012	RP-57	RP-121313	1305			Correction to PCFICH power parameter setting	10.8.0
09-2012	RP-57	RP-121306	1308r 1			Correction on frequency non-selective CQI test	10.8.0
09-2012	RP-57	RP-121306	1311r 1			eDL-MIMO CQI/PMI test	10.8.0
09-2012	RP-57	RP-121313	1315			Correction of the definition of unsynchronized operation	10.8.0
09-2012	RP-57	RP-121304	1319r 1			Correction to Transmit Modulation Quality Tests for Intra-Band CA	10.8.0
09-2012	RP-57	RP-121304	1331r 1			Bandwidth combination sets for intra-band and inter-band carrier aggregation	10.8.0
09-2012	RP-57	RP-121306	1349r 1			FRC for TM9 FDD	10.8.0
09-2012	RP-57	RP-121295	1350			Random precoding granularity in PMI tests	10.8.0
09-2012	RP-57	RP-121302	1357			Introduction of RI test for eICIC	10.8.0
09-2012	RP-57	RP-121304	1359			Notes for deltaTib and deltaRib tables	10.8.0
12-2012	RP-58	RP-121861	1365r 1			Some changes related to CA tests and overview table of DL measurement channels	10.9.0
12-2012	RP-58	RP-121860	1367			Correction of eICIC CQI tests	10.9.0
12-2012	RP-58	RP-121860	1369			Correction of eICIC demodulation tests	10.9.0
12-2012	RP-58	RP-121862	1372r 1			Correction of SNR definition	10.9.0
12-2012	RP-58	RP-121862	1373			Correction on CSI-RS subframe offset parameter	10.9.0
12-2012	RP-58	RP-121862	1375r 1			Correction on FRC table in CSI test	10.9.0
12-2012	RP-58	RP-121862	1381			Correction of reference channel table for TDD eDL-MIMO RI test	10.9.0
12-2012	RP-58	RP-121850	1385			OCNG patterns for Sustained Data rate testing	10.9.0
12-2012	RP-58	RP-121867	1387r 1			Introduction of one periodic CQI test for CA deployments	10.9.0
12-2012	RP-58	RP-121850	1400			Introducing the additional frequency bands of 5 MHz x 2 in 1.7 GHz in Japan to Band 3	10.9.0
12-2012	RP-58	RP-121860	1403			CR on eICIC RI test	10.9.0
12-2012	RP-58	RP-121861	1404			Correction of some errors in reference sensitivity for CA in TS 36.101 (R10)	10.9.0
12-2012	RP-58	RP-121862	1408r 1			Cleaning of 36.101 Performance sections Rel-10	10.9.0
12-2012	RP-58	RP-121861	1415r 1			Out-of-band blocking requirements for inter-band carrier aggregation	10.9.0
12-2012	RP-58	RP-121860	1417r 1			Brackets clean up for eICIC CSI/demodulation	10.9.0
12-2012	RP-58	RP-121867	1430			Clean up of specification R10	10.9.0
12-2012	RP-58	RP-121867	1435r 1			Band 1 to Band 33 and Band 39 UE coexistence requirements	10.9.0
12-2012	RP-58	RP-121862	1441			Correction of eDL-MIMO RI test and RMC table for the CSI test	10.9.0
12-2012	RP-58	RP-121861	1443			Minor correction to ceiling function example - rel10	10.9.0
12-2012	RP-58	RP-121860	1454r 1			CR on eICIC RI testing (Rel-10)	10.9.0
12-2012	RP-58	RP-121862	1458			Correction on FRC table	10.9.0
12-2012	RP-58	RP-121862	1463			Adding references to the appropriate beamforming model (Rel-10)	10.9.0
12-2012	RP-58	RP-121866	1466			Maintenance of Band 23 UE Coexistence	10.9.0
12-2012	RP-58	RP-121849	1493			Low-channel Band 1 coexistence with PHS	10.9.0
12-2012	RP-58	RP-121852	1508			UE-UE coexistence between bands with small frequency separation	10.9.0
12-2012	RP-58	RP-121860	1512			Applicable OFDM symbols of Noc_2 for PDCCH/PCFICH ABS-MBSFN test cases	10.9.0
12-2012	RP-58	RP-121851	1514			Corrections to TM4 rank indicator Test 3	10.9.0
12-2012	RP-58	RP-121861	1516			Correction of test configurations and FRC for CA demodulation with power imbalance	10.9.0
03-2013	RP-59	RP-130268	1522			Brackets removal in Rel-10 TM4 rank indicator Test 3	10.10.0

03-2013	RP-59	RP-130258	1527			Corrections to CQI reporting	10.10.0
03-2013	RP-59	RP-130264	1533r 2			CR for CA performance requirements	10.10.0
03-2013	RP-59	RP-130262	1535			Corrections for eICIC performance requirements (rel-10)	10.10.0
03-2013	RP-59	RP-130264	1538			Correction of CA power imbalance performance requirements	10.10.0
03-2013	RP-59	RP-130263	1542r 3			Clarification of spurious emission domain for CA in TS 36.101 (R10)	10.10.0
03-2013	RP-59	RP-130263	1556r 1			CA_1C: CA_NS_02 and CA_NS_03 A-MPR REL-10	10.10.0
03-2013	RP-59	RP-130267	1561r 1			Addition of UE Regional Requirements to Band 23 Based on New Regulatory Order in the US	10.10.0
03-2013	RP-59	RP-130260	1573			Remove [] from CSI test case parameters	10.10.0
03-2013	RP-59	RP-130268	1578			UE-UE co-existence between Band 1 and Band 33/39	10.10.0
03-2013	RP-59	RP-130263	1583r 1			Cleanup for CA UE RF requirements	10.10.0
03-2013	RP-59	RP-130263	1585			Corrections on UL configuration for CA UE receiver requirements	10.10.0
03-2013	RP-59	RP-130263	1587			Correction of Transmit modulation quality requirements for CA	10.10.0
03-2013	RP-59	RP-130268	1589			Revision of Common Test Parameters for User-specific Demodulation Tests	10.10.0
03-2013	RP-59	RP-130264	1596			Correction of CA CQI test setup	10.10.0
03-2013	RP-59	RP-130263	1601			Correction of table reference	10.10.0
06-2013	RP-60	RP-130765	1603			Complementary description for definition of MIMO Correlation Matrices using cross polarized antennas	10.11.0
06-2013	RP-60	RP-130763	1606			Correction of transport format parameters for CQI index 10 (15 RBs) - Rel 10	10.11.0
06-2013	RP-60	RP-130765	1609			Maintenance of Band 23 A-MPR (NS_11) in TS 36.101 (Rel-10)	10.11.0
06-2013	RP-60	RP-130765	1622r 1			Correction of test parameters for eICIC performance requirements	10.11.0
06-2013	RP-60	RP-130765	1624			Correction of test parameters for eICIC CSI requirements	10.11.0
06-2013	RP-60	RP-130765	1626r 1			Correction of resource allocation for the multiple PMI Cat 1 UE test	10.11.0
06-2013	RP-60	RP-130767	1630			Minor correction for CA CQI test setup	10.11.0
06-2013	RP-60	RP-130765	1655r 1			Modification of configured output power to account for larger tolerance	10.11.0
06-2013	RP-60	RP-130765	1680r 1			Correction for TS 36.101	10.11.0
06-2013	RP-60	RP-130763	1683			RF: Corrections to RMC-s for sustained data rate test	10.11.0
06-2013	RP-60	RP-130766	1688			Carrier aggregation in multi RAT and multiple band combination terminals	10.11.0
06-2013	RP-60	RP-130766	1690r 1			Completion of out-of-band blocking requirements for inter-band CA with one UL	10.11.0
06-2013	RP-60	RP-130767	1694r 1			CR on the bandwidth coverage issue of CA demodulation performance (Rel-10)	10.11.0
06-2013	RP-60	RP-130765	1696r 1			Correction on UE maximum output power for intra-band CA (R10)	10.11.0
06-2013	RP-60	RP-130767	1702			CR on the bandwidth coverage issue of CA CQI performance(Rel-10)	10.11.0
06-2013	RP-60	RP-130766	1704			Corrections to ACLR for Rel-10 CA	10.11.0
06-2013	RP-60	RP-130770	1708			Corrections for co-existence(Rel-10)	10.11.0
06-2013	RP-60	RP-130765	1715			Corrections to NS_11 A-MPR Table	10.11.0
09-2013	RP-61	RP-131281	1734			CR on applicability of CA sustained data rate tests (Rel-10)	10.12.0
09-2013	RP-61	RP-131281	1737			Correction of the CA capabilities for the soft buffer tests (Rel-10)	10.12.0
09-2013	RP-61	RP-131281	1759r 1			Correction of the missing frequency range for B7 UE co-existence requirements in R10	10.12.0
09-2013	RP-61	RP-131281	1765			UE REFSENS when supporting intra-band CA and inter-band CA	10.12.0
09-2013	RP-61	RP-131279	1770			Correlation matrix for high speed train demodulation scenarios (Rel-10)	10.12.0
09-2013	RP-61	RP-131280	1774			Corrections to sustained data rate test (Rel-10)	10.12.0
09-2013	RP-61	RP-131281	1792r 1			Clarification of "multi-cluster" transmission	10.12.0
09-2013	RP-61	RP-131281	1798r 1			CA UE Coexistence Table update (Release 10)	10.12.0
09-2013	RP-61	RP-131281	1805			Incorrect REFSENS UL allocation for CA_1C	10.12.0
09-2013	RP-61	RP-131281	1809			Contiguous intraband CA REFSENS with one UL	10.12.0
09-2013	RP-61	RP-131281	1817			Correction to Rel-10 A-MPR for CA_NS_04: This CR is NOT implemented as it is based on a wrong	

					version of the Spec	
09-2013	RP-61	RP-131281	1818r 1		The Pcmx clauses restructured	10.12.0
12-2013	RP-62	RP-131928	1845r 1		Corrections to the notes in the band UE co-existence requirements table (Rel-10)	10.13.0
12-2013	RP-62	RP-131924	1850		Clean-up of uplink reference measurement channels (Rel-10)	10.13.0
12-2013	RP-62	RP-131928	1875r 2		Intraband CA channel bandwidth combination table restructuring	10.13.0
12-2013	RP-62	RP-131926	1902		Correction on the UE category for eICIC CQI test	10.13.0
12-2013	RP-62	RP-131928	1914r 2		Allowed power reductions for multiple transmissions in a subframe	10.13.0
12-2013	RP-62	RP-131927	1920		CR on correction of FRC of power imbalance test	10.13.0
12-2013	RP-62	RP-131927	1935		UE-UE coexistence for Band 40	10.13.0
12-2013	RP-62	RP-131927	1943		CR Removing Addition of DTc to P-MPR	10.13.0
12-2013	RP-62	RP-131928	1982r 1		Correction to blocking requirements and use of Delta_Rib	10.13.0
12-2013	RP-62	RP-131924	2012		P-max for Band 38 to Band 7 coexistence	10.13.0
12-2013	RP-62	RP-131928	2033r 1		Nominal guard bands for CA bandwidth classes A and C	10.13.0
12-2013	RP-62	RP-131926	2038		CA_1C: Correction on CA_NS_02 A-MPR table	10.13.0
12-2013	RP-62	RP-131924	2063		Simplification of Band 12/17 in-band blocking test cases CR was not implemented as it was not based on the latest version of the spec	10.13.0
03-2014	RP-63	RP-140368	2090		CR for structure change of CA soft buffer tests in Rel-10	10.14.0
03-2014	RP-63	RP-140368	2087r 1		CR for introduction of 15MHz based SDR tests and test point table in Rel-10	10.14.0
03-2014	RP-63	RP-140368	2145		Correction of coding rate for 18RBs in UL RMC table	10.14.0
03-2014	RP-63	RP-140368	2135		Configured transmitted power for CA	10.14.0
03-2014	RP-63	RP-140368	2120		CR for 36.101. Editorial correction on OCNNG pattern	10.14.0
06-2014	RP-64	RP-140911	2231		Clarification of Intra-band contiguous CA class C Narrow band blocking requirements	10.15.0
06-2014	RP-64	RP-140911	2267r 1		Additional correction to In-band blocking case numbering re-establishment	10.15.0
06-2014	RP-64	RP-140909	2300r 3		RF: Corrections to spurious emission requirements with NS different than NS_01 (Rel-10)	10.15.0
06-2014	RP-64	RP-140911	2312r 2		UE to UE co-existence between B42/B43	10.15.0
06-2014	RP-64	RP-140911	2316		Perf: Corrections to CA (Class C) performance with power imbalance (Rel-10)	10.15.0
06-2014	RP-64	RP-140911	2326		Clean-up CR for demodulation requirements (Rel-10)	10.15.0
06-2014	RP-64	RP-140911	2331		Throughput calculation for eICIC demodulation requirements	10.15.0
06-2014	RP-64	RP-140911	2339		Cleanup of terminology for Rx requirements	10.15.0
06-2014	RP-64	RP-140911	2342		CR on separating CA UE demodulation tests from single carrier tests in Rel-10	10.15.0
06-2014	RP-64	RP-140911	2345		CR on correction on CA capability in Rel-10	10.15.0
06-2014	RP-64	RP-140911	2349		Test configuration for intra-band contiguous carrier aggregation power control	10.15.0
06-2014	RP-64	RP-140911	2363		Clarification on CA bandwidth classes	10.15.0
06-2014	RP-64	RP-140911	2364		Clarification on CA bandwidth classes	10.15.0
06-2014	RP-64	RP-140911	2365		Clarification on CA bandwidth classes	10.15.0
06-2014	RP-64	RP-140911	2375		Corrections on CA CQI tests	10.15.0
06-2014	RP-64	RP-140911	2389		CR on PDSCH transmission for eICIC CSI requirements (Rel-10)	10.15.0
06-2014	RP-64	RP-140911	2426		Simplification of Band 12/17 in-band blocking test cases	10.15.0
09-2014	RP-65	RP-141525	2502		Perf: Cleanup and better description of DL-RMC-s with dynamic coding rate for CSI requirements (Rel-10)	10.16.0
09-2014	RP-65	RP-141525	2563		Corrections to UE coex table	10.16.0
09-2014	RP-65	RP-141527	2432		Correction on support of a bandwidth combination set	10.16.0
09-2014	RP-65	RP-141527	2451		Remove the invalid TDD single-antenna test and maintenance of applicability table for CA sustained data rate test (Rel-10)	10.16.0
09-2014	RP-65	RP-141527	2464		Unequal DL CC RB allocations in Maximum input level	10.16.0
09-2014	RP-65	RP-141527	2467		Intra-band contiguous CA ACS case 2 test clarification	10.16.0
09-2014	RP-65	RP-141527	2476		CQI reporting under fading: CQI indices in set	10.16.0
09-2014	RP-65	RP-141527	2482r 1		Corrections on delta Tc for UE MOP for intra-band contiguous CA	10.16.0
09-2014	RP-65	RP-141527	2485		Removal of Class B in UE TX requirement	10.16.0
09-2014	RP-65	RP-141527	2514r 1		CR for CA applicability rule in 36.101 in Rel-10	10.16.0
09-2014	RP-65	RP-141527	2517		Editorial CR for CA performance tests in 36.101 in Rel-10	10.16.0
09-2014	RP-65	RP-141527	2520		CR on CA power imbalance tests in Rel-10	10.16.0

09-2014	RP-65	RP-141527	2546			Correction to NS_20 A-MPR for Band 23	10.16.0
12-2014	RP-66	RP-142144	2577			Correction on out-of-band blocking for intra-band CA	10.17.0
12-2014	RP-66	RP-142142	2585			CR for 1 PRB allocation performance in presence of MBSFN (rel-10)	10.17.0
12-2014	RP-66	RP-142144	2588			Maintenance of CA demodulation performance requirements (Rel-10)	10.17.0
12-2014	RP-66	RP-142144	2635			Defintion of the bits in the bitmap for indication of modified MPR behavior	10.17.0
12-2014	RP-66	RP-142147	2618r 1			CQI reporting in AWGN: CQI indices in set	10.17.0
12-2014	RP-66	RP-142144	2572r 1			CR for REFSENSE in lower SNR and change history	10.17.0
12-2014	RP-66	RP-142144	2686			Removal of bracket for UL MIMO	10.17.0
12-2014	RP-66	RP-142144	2698			Delete the incorrect notes for FDD DMRS demodulation tests (Rel-10)	10.17.0
12-2014	RP-66	RP-142144	2718			Band 22 correction in UE to UE co-existence table.	10.17.0
12-2014	RP-66	RP-142144	2748			Correction to Transmit Modulation Quality for CA	10.17.0
12-2014	RP-66	RP-142144	2674r 1			CR to remove CA capability column in CA performance test tables (Rel-10)	10.17.0
12-2014	RP-66	RP-142144	2725r 1			CR for CA applicability rule in 36.101 in Rel-10	10.17.0
12-2014	RP-66	RP-142144	2708r 1			Clarification of UL and DL CA configuration	10.17.0
12-2014	RP-66	RP-142144	2715r 1			Clarification of notes relating to interferer offsets in intrabnd CA receiver requirement tables.	10.17.0
12-2014	RP-66	RP-142144	2756			Correction to Note 2 of Harmonic Signal Exceptions in Spurious Emissions	10.17.0
12-2014	RP-66	RP-142144	2749r 1			Removal of brackets and TBD from CA feature	10.17.0
12-2014	RP-66	RP-142144	2695r 1			Maintenance of CA performance requirements (Rel-10)	10.17.0
12-2014	RP-66	RP-142144	2702r 2			UE to UE co-existence between B42/B43	10.17.0
03-2015	RP-67	RP-150382	2795			UL HARQ in PDSCH and PDCCH/PCFICH demod test cases for eICIC with MBSFN ABS	10.18.0
03-2015	RP-67	RP-150382	2798			Correction to eICIC aggressor cell configurations	10.18.0
03-2015	RP-67	RP-150382	2803			Removal of eDL-MIMO term from specification	10.18.0
03-2015	RP-67	RP-150382	2817			UE to UE co-existence between B42/B43	10.18.0
03-2015	RP-67	RP-150382	2820			Corrections to CA in-band emissions requirement	10.18.0
03-2015	RP-67	RP-150381	2828			Uplink RMCs for sustained data rate test	10.18.0
03-2015	RP-67	RP-150382	2831			Corrections to the CA power imbalance test	10.18.0
03-2015	RP-67	RP-150392	2840			Editorial CR for CA UE performance tests in 36.101 in Rel-10	10.18.0
03-2015	RP-67	RP-150382	2845			UE spurious emissions structure correction for CA	10.18.0
03-2015	RP-67	RP-150382	2848r 1			Removal of Pmax requirements for UL inter-band CA in early release	10.18.0
07-2015	RP-68	RP-150954	2868			Intra-band contiguous CA reference sensitivity definition for Class D	10.19.0
07-2015	RP-68	RP-150954	2899			UE to UE co-existence between B42/B43	10.19.0
07-2015	RP-68	RP-150954	2929r 1			3.5 GHz out-of-band blocking	10.19.0
07-2015	RP-68	RP-150958	2945			Updates to the definitions of CA capability (Rel-10)	10.19.0
07-2015	RP-68	RP-150954	2954r 1			NS value for intra-band contiguous CA configurations not allowed A-MPR	10.19.0
07-2015	RP-68	RP-150954	2969r 1			Corrections to NS_22 and NS_23	10.19.0
07-2015	RP-68	RP-150954	2990			Clarification to spurious emission requirement for the edge of spurious domain	10.19.0
07-2015	RP-68	RP-150958	3000			CR for updating CA applicability rule in 36.101 in Rel-10	10.19.0
07-2015	RP-68	RP-150954	3014r 1			Clarification to Inter-band CA test configuration requirement	10.19.0
07-2015	RP-68	RP-150954	3015			EVM for Intra-band contiguous UL CA for non-equal Channel BWs	10.19.0
09-2015	RP-69	RP-151475	3037			Correction to RI test parameters in TS 36.101 (Rel-10)	10.20.0
09-2015	RP-69	RP-151483	3047			UE co-existence requirements between Band 42 and Japanese bands	10.20.0
09-2015	RP-69	RP-151475	3073			Correction to PDCCH/PCFICH test parameters in TS 36.101 (Rel-10)	10.20.0
09-2015	RP-69	RP-151475	3077			Correction to PMI delay in PMI test for TDD	10.20.0
09-2015	RP-69	RP-151475	3099			Correction on UE maximum output power class of Band 22 for UL MIMO	10.20.0
09-2015	RP-69	RP-151475	3162			Correction of applicability of CA_NS_31	10.20.0
12-2015	RP-70	RP-152131	3168a			Corrections to applicability of CSI requirements for low UE categories (Rel-10)	10.21.0
12-2015	RP-70	RP-152130	3199r			CR: Removal of 1.4MHz MBMS test (Rel-10)	10.21.0

			1				
12-2015	RP-70	RP-152130	3229			Correction to reference channel for CQI requirements	10.21.0
12-2015	RP-70	RP-152131	3266r 1			Clarification of Pcell support in 36.101 Rel-11 in CA scenarios	10.21.0
12-2015	RP-70	RP-152131	3282			Missing RB allocation and OCNG Pattern for Cat 1 UEs in Multiple PMI CSI Reference Symbol tests	10.21.0
03/2016	RP-71	RP-160487	3470		D	CR of editorial change on PHICH group and Ng in Rel-10	10.22.0
03/2016	RP-71	RP-160487	3400	1	F	[Rel-10] NS_05 modification for PHS protection in Japan	10.22.0
09/2016	RP-73	RP-161632	3652		F	Improving the single antenna port description in UL-MIMO clauses	10.23.0
09/2016	RP-73	RP-161632	3795		F	Correction of OCNG (Rel-10)	10.23.0
12/2016	RP-74	RP-162411	4018		F	RMCs and applicability of core RF requirements	10.24.0
12/2016	RP-74	RP-162411	4027		F	Correction of spurious emissions requirements for Band 9 range and intra-band CA	10.24.0
12/2016	RP-74	RP-162406	4098		F	Versioning indicator bit for NS_04 A-MPR table	10.24.0
01/2017	RP-74					Update of the page header information	10.24.1
09/2017	RP-77	RP-171965	4519	2	F	Correction of band 43 spurious emissions limit (Rel-10)	10.25.0
09/2017	RP-77	RP-171964	4593		A	Correction for EPA delay profiles of r.m.s delay spread (Rel-10)	10.25.0
2018-03	RAN#79	RP-180285	4942		F	PC2 for CA_41C REL-10	10.26.0
2018-06	RAN#80	RP-181105	5016	1	F	Cat.F CR for UE-to-UE co-existence for Band 3 in Japan (Rel-10)	10.27.0
2018-06	RAN#80	RP-181106	5046	2	F	CR: Corrections for CSI tests (Rel-10)	10.27.0
2018-09	RAN#81	RP-181908	5185	1	F	Correction on Table 7.3.1-3 Network signalling value for reference sensitivity	10.28.0
2021-03	RAN#91	RP-210111	5714	1	F	CR for 36.101: Corrections related to Band 24 regulatory updates	10.29.0
2021-06	RAN#92	RP-211092	5751	1	F	CR for updates related to LTE band 24 in 36.101 (Rel-10)	10.30.0

History

Document history		
V10.1.1	January 2011	Publication
V10.2.1	May 2011	Publication
V10.3.0	June 2011	Publication
V10.4.0	November 2011	Publication
V10.5.0	January 2012	Publication
V10.6.0	March 2012	Publication
V10.7.0	July 2012	Publication
V10.8.0	November 2012	Publication
V10.9.0	February 2013	Publication
V10.10.0	April 2013	Publication
V10.11.0	July 2013	Publication
V10.12.0	October 2013	Publication
V10.13.0	March 2014	Publication
V10.14.0	April 2014	Publication
V10.15.0	August 2014	Publication
V10.16.0	November 2014	Publication
V10.17.0	April 2015	Publication
V10.18.0	May 2015	Publication
V10.19.0	August 2015	Publication
V10.20.0	October 2015	Publication
V10.21.0	April 2016	Publication
V10.22.0	May 2016	Publication
V10.23.0	December 2016	Publication
V10.24.1	March 2017	Publication
V10.25.0	November 2017	Publication
V10.26.0	April 2018	Publication
V10.27.0	October 2018	Publication
V10.28.0	January 2019	Publication
V10.29.0	May 2021	Publication
V10.30.0	September 2021	Publication